

University of Warwick institutional repository: <http://go.warwick.ac.uk/wrap>

A Thesis Submitted for the Degree of PhD at the University of Warwick

<http://go.warwick.ac.uk/wrap/2799>

This thesis is made available online and is protected by original copyright.

Please scroll down to view the document itself.

Please refer to the repository record for this item for information to help you to cite it. Our policy information is available from the repository home page.

**An Agent-Based Model of Energy
in Social Networks**

by

Christopher John Watts

A thesis submitted in partial fulfilment of the requirements for the

degree of

PhD from the University of Warwick

University of Warwick, Warwick Business School

September 2009

Contents

Contents	i
List of figures	x
List of tables	xiv
Acknowledgements	xv
Thesis Summary	xvi
Abbreviations	xvii
Chapter 1 Understanding how work really gets done in organisations	1
1.1 Introduction: Models of agents with energy	1
1.2 Understanding organisations: the role of Operational Research and simulation	3
1.3 Groups, boundaries and the take-up of innovations	8
1.3.1 Ethnography	8
1.3.2 Social Network Analysis	9
1.3.3 Computer models	12
1.4 Cross and Parker’s three claims about energisers	13
1.5 Other approaches	17
1.6 The aim and organisation of the thesis	19
Chapter 2 What is “energy”?	23
2.1 Introduction and context	23
2.2 What energy is not: Physics and Physiology	26
2.3 A unified concept?: feelings of energy	28
2.4 Intrinsic motivation	30
2.5 Emotional Energy in Interaction Rituals	31
2.6 Distinguishing concepts: Energisers and Energy Leaders	33

2.7 How to measure energy?	36
2.8 Summary	41
Chapter 3 How might we model energy?	43
3.1 Introduction	43
3.2 Network models	49
3.3 Models of contagion and social learning	53
3.4 Models of Groups and Culture	58
3.4.1 Homophily & Small Worlds	58
3.4.2 Homophily & Imitation	60
3.4.3 Polarisation and Alliance Formation	61
3.4.4 Altruism, Tags and Ethnic Conflict	62
3.5 Models of Work Performance	65
3.6 Models of Human Agents	69
3.6.1 BDI: Rational decision making and action	69
3.6.2 Reinforcement Learning, adaptive agents and SOAR	71
3.6.3 The PECS framework: Emotion and social status	72
3.7 Summary	75
Chapter 4 The Baker-Quinn Model: a Critique	77
4.1 Introduction	77
4.2 Positives	77
4.3 Questions about the model design	79
4.4 Is it a model of energy?	83
4.5 Is it a model of information?	84
4.6 An attempt at model replication	86
4.7 How good is the empirical validation?	88

4.8 Conclusions about the Baker-Quinn Model	91
Chapter 5 Justifying the use of agent-based simulation modelling	93
5.1 The Research Objectives	93
5.2 Introduction to our methodology	94
5.3 Why use simulation modelling?	94
5.4 Two paradigms for simulation modelling	97
5.5 Science as coalition formation	105
5.6 Which simulations make for good coalitions?	113
5.7 Comparing simulation approaches	115
5.8 Summary	117
Chapter 6 A family of energy models	119
6.1 Introduction	119
6.2 Starting with the Axelrod Cultural Model (ACM)	121
6.2.1 Why build from the ACM?	121
6.2.2 The ACM as a model of Interaction Rituals	125
6.3 The base model: a version of the ACM	128
6.4 Introducing Energy	134
6.5 The Interaction Ritual Memory	140
6.5.1 Base Model	141
6.5.2 The Agent-Energy Model (AgentE)	141
6.5.3 The Feature-Energy Model (FeatureE)	145
6.5.4 The Interaction Ritual Memory (IRM)	147
6.6 The A, B and C of Energy Payoffs	159
6.7 Energisers and De-energisers	164
6.8 Summary	172

Chapter 7 Testing Cross & Parker's Claims	173
7.1 Introduction	173
7.2 Testing Cross & Parker's Claims	174
7.3 Experimental Design	179
7.3.1 Population size, network structure and energising parameter values	180
7.3.2 Payoff functions	180
7.3.3 Decay rates and half lives	181
7.3.4 Features, traits and memory sizes	183
7.3.5 Simulation initialisation, iterations and replications	184
7.4 Technical Issues	187
7.4.1 Coding a simulation model	187
7.4.2 Random number generation	188
7.4.3 Data processing	189
7.5 Seeing and Believing in an Agent-Based Model	189
7.6 Summary	196
Chapter 8 Energy applied to agents	197
8.1 Introduction	197
8.2 Relating the energy model to the ACM	197
8.3 Claim 1: The take up of ideas	200
8.4 Claim 2: The size of an agent's region	208
8.5 Claim 3: Improvement in fitness	210
8.6 Summary for the agent-energy model	212
Chapter 9 Energy applied to features	215
9.1 Introduction	215
9.2 Attempting to relate feature-energy and agent-energy models	215

9.3 Testing the claims in the feature-energy and agent-energy models	223
9.4 Summary for the feature-energy model	224
Chapter 10 Energy applied to IR Memories	226
10.1 Introduction	226
10.2 Testing the claims	227
10.3 How the IRAM behaves	230
10.4 Increasing the size of the IR Memory	234
10.5 Analysis of Entropy in the Interaction Ritual Agents Model (IRAM)	240
10.5.1 Tests on entropy measures	247
10.5.2 Further research from the entropy metrics	252
10.6 Summary for models with multi-item IR Memory	252
Chapter 11 Mavericks and Boundary Spanners	255
11.1 Introduction	255
11.2 The Maverick Scenario	256
11.3 The Boundary Spanner Scenario	258
11.4 The Experiments	259
11.5 Results for the Agent-Energy Model	259
11.6 Further Models	262
11.7 Discussion	265
Chapter 12 Discussion	267
12.1 Introduction	267
12.2 Models of agents with energy	268
12.3 Experiments on “energisers”	274
12.4 Strengths and Limitations	280
12.5 Avenues for further research	283

12.5.1 Further factors	283
12.5.2 Docking with other models	286
12.5.3 Problem solving in the world of <i>homo sociologicus</i>	288
12.5.4 Further questions about culture	289
12.5.5 Energy, autonomy and self-determination	290
12.5.6 Energy, attention and stratification	291
12.5.7 Energy and creativity	293
12.5.8 Summary of further research	294
12.6 Concluding remarks	294
Appendix A System Dynamics models	296
A.1 Introduction	296
A.2 The Axelrod Cultural Model as stocks and flows	296
A.3 The behaviour of the system dynamics ACM	299
A.4 Towards a system dynamics agent-energy model	302
A.5 Conclusions regarding system dynamics models	304
Appendix B Results with the agent-energy model (AgentE)	306
B.1 Introduction	306
B.2 Agent-energy behaviour	307
B.2.1 Payoff: Belongingness; Energising: Belongingness (B=E)	308
B.2.2 Payoff: Autonomy; Energising: Autonomy (A=E)	309
B.2.3 Payoff: Autonomy & Belongingness; Energising: Autonomy (A=E, B=1)	310
B.2.4 Payoff: Belongingness & Autonomy; Energising: Belongingness (B=E, A=1)	311

B.2.5 Payoff: Belongingness & Competence; Energising: Belongingness (B=E, C=1)	312
B.2.6 Payoff: Competence; Energising: Competence (C=E)	313
B.2.7 Payoff: Competence & Belongingness; Energising: Competence (C=E, B=1)	314
B.2.8 Payoff: Belongingness; Energising: Belongingness; Population = 10 (B=E, N=10)	315
B.3 Claims Tests	316
B.3.1 Claim 1: Based on Frequency of being imitated	317
B.3.2 Other claims tests	317
Appendix C Results with the feature-energy model (FeatureE)	319
C.1 Introduction	319
C.2 Feature-energy model behaviour	320
C.2.1 Payoff: Belongingness; Energising: Belongingness (B=E)	321
C.2.2 Payoff: Belongingness & Competence; Energising: Belongingness (B=E, C=1)	322
C.2.3 Payoff: Competence; Energising: Competence (C=E)	323
C.2.4 Payoff: Competence & Belongingness; Energising: Competence (C=E, B=1)	324
C.3 Claims Tests	325
C.3.1 Claim 1: Based on Frequency of being imitated	325
C.3.2 Other claims tests	325
Appendix D Results with the Interaction Ritual Agents Model (IRAM)	326
D.1 Introduction	326
D.2 IRAM behaviour	327

D.2.1 Payoff: Belongingness; Energising: Belongingness (B=E)	328
D.2.2 Payoff: Belongingness & Competence; Energising: Belongingness (B=E, C=1)	329
D.3 Claims Tests	330
D.3.1 Claim 1: Based on Frequency of being imitated	330
D.3.2 Other claims tests	330
Appendix E Results with the IR Memory Model (IRM model)	332
E.1 Introduction	332
E.2 IRM model behaviour	332
E.2.1 Frequency of being imitated - by memory size (m)	333
E.2.2 Size of agent's region - by memory size (m)	334
E.2.3 Frequency of being imitated - by half life	335
E.2.4 Size of agent's region - by half life	336
E.2.5 Frequency of being imitated - by (q / F)	337
E.2.6 Size of agent's region - by (q / F)	338
E.3 Claims Tests	339
E.3.1 Claim 1: Based on Frequency of being imitated	339
E.3.2 Claim 2: Based on Size of agent's region	340
Appendix F The world of "Homo Sociologicus"	341
F.1 Introduction	341
F.2 Social interaction and agent memory	342
F.3 Energy decay, Expected Gain and innovation	345
F.4 Autonomy, dominance and stratification	346
F.5 Groups and Belongingness	347
F.6 Traits, features and cultural complexity	350

F.7 Benchmark problems	351
F.8 Conclusions	353
Bibliography	354

List of figures

<i>Figure 1 The formation of interaction ritual chains</i>	47
<i>Figure 2 A population of “hawks” and “doves” reaches an evolutionarily stable strategy (ESS)</i>	56
<i>Figure 3 Equations 1 and 2 from the Baker-Quinn Model</i>	80
<i>Figure 4 Energy levels and Relational Energy in the basic version of the Baker-Quinn Model</i>	82
<i>Figure 5 Aggregate statistics of 500 replications of our reconstruction of the Baker-Quinn Hierarchy Model</i>	87
<i>Figure 6 Illustrative aggregate statistics of the Baker-Quinn Hierarchy Model</i>	89
<i>Figure 7 The matrix of relational energy values</i>	90
<i>Figure 8 Example of a linear, positivist approach to understanding simulation modelling</i>	100
<i>Figure 9 Example of an interpretivist approach to understanding simulation modelling</i>	102
<i>Figure 10 Recognition of the fact that the modelling process has costs determined by extrinsic factors</i>	104
<i>Figure 11 A coalition of concepts</i>	107
<i>Figure 12 The basic structure of our base model – a version of the Axelrod Cultural Model</i>	128
<i>Figure 13 Simulation initialisation in the base model</i>	129
<i>Figure 14 Output metrics in the base model</i>	131
<i>Figure 15 A simulation iteration in the base model</i>	133
<i>Figure 16 One agent’s attributes in the Base model – based on the Axelrod Cultural Model</i>	141
<i>Figure 17 The agent-energy model (AgentE)</i>	143
<i>Figure 18 The feature-energy model (FeatureE)</i>	146

<i>Figure 19 Turning the feature-energy model on its side</i>	148
<i>Figure 20 The IR Memory</i>	149
<i>Figure 21 A model with IR Memory</i>	150
<i>Figure 22 The full Interaction Ritual Agents Model (IRAM)</i>	152
<i>Figure 23 Method for updating IR Memory with the details of a new IR event</i>	159
<i>Figure 24 Payoffs pre- and post-energising</i>	169
<i>Figure 25 Payoffs post-energising for prior payoffs of 0, 0.5 and 1</i>	169
<i>Figure 26 Post energising/de-energising payoff as a function of the energising parameter</i>	170
<i>Figure 27 Two grid displays from an agent-energy model</i>	191
<i>Figure 28 Output showing simulation evolution</i>	192
<i>Figure 29 The simulation's iterations displayed individually</i>	194
<i>Figure 30 Depictions of "culture space"</i>	195
<i>Figure 31 Comparing the agent-energy model to the Axelrod Cultural Model</i>	198
<i>Figure 32 Cultural diversity measures plotted against q / F</i>	199
<i>Figure 33 Frequency of being imitated, given by q / F and half life, for the agent-energy model</i>	201
<i>Figure 34 Difference in frequency of being imitated between Energiser ($E=1/6$) and the mean of the non-energiser agents</i>	203
<i>Figure 35 Difference in frequency of being imitated between the mean of the non-de-energiser agents and a De-energiser ($E=6$)</i>	204
<i>Figure 36 Comparing the 1 energiser/de-energiser with the other 19 agents, for Frequency of being imitated</i>	205
<i>Figure 37 Results from systematic searches for Frequency of being imitated</i>	207
<i>Figure 38 Size of agent's region, given by q / F and half life, for the agent-energy model</i>	210
<i>Figure 39 Comparing the feature-energy model ("FeatureE") to the agent-energy model ("AgentE") for Frequency of being imitated</i>	216
<i>Figure 40 Comparing the feature-energy model ("FeatureE") to the agent-energy model ("AgentE") for Size of agent's region</i>	217

<i>Figure 41 % difference between the feature-energy model (“FeatureE”) and the agent-energy model (“AgentE”)</i>	217
<i>Figure 42 Energy charges due to Belongingness in the feature-energy model (“FeatureE”) and the agent-energy model (“AgentE”)</i>	218
<i>Figure 43 Expected initial probabilities for successful IRs</i>	221
<i>Figure 44 Probability of a feature decaying from 0.5 being selected ahead of one decaying from 1</i>	222
<i>Figure 45 Test scores using Frequency of being imitated for the feature-energy model (“FeatureE”) and the agent-energy model (“AgentE”)</i>	224
<i>Figure 46 Test scores using Frequency of being imitated for the IRAM</i>	228
<i>Figure 47 Test scores using Size of agent’s region for the IRAM</i>	228
<i>Figure 48 Test scores for the IRAM with 138 simulation replications</i>	229
<i>Figure 49 Test scores for an IRAM with payoff function based on Belongingness and Competence (B=E, C=1)</i>	229
<i>Figure 50 Test scores for claim 3 for an IRAM</i>	230
<i>Figure 51 Comparing the IRAM with m=8 memory size to the agent-energy model (“AgentE”) for Frequency of being imitated</i>	231
<i>Figure 52 Comparing the IRAM with m=8 memory size to the agent-energy model (“AgentE”) for Size of agent’s region</i>	232
<i>Figure 53 Comparing the IRAM with m=8 memory size to the agent-energy model (“AgentE”) for Fitness Improvement</i>	233
<i>Figure 54 Frequency of being imitated for IRAM and AgentE –with payoff function based on Belongingness and Competence (B=E, C=1)</i>	234
<i>Figure 55 Size of agent’s region for IRAM and AgentE with payoff function based on Belongingness and Competence (B=E, C=1)</i>	234
<i>Figure 56 Frequency of being imitated for the IRM model with values of memory size m from 1 to 8</i>	236

<i>Figure 57 Size of agent's region for the IRM model with values of memory size m from 1 to 8</i>	237
<i>Figure 58 Representative runs of the IRM model</i>	238
<i>Figure 59 Test scores for claims 1 and 2 for the IRM with $m=8$ memory size</i>	239
<i>Figure 60 Outputs from IRM with $(q/F) = 2$</i>	240
<i>Figure 61 Entropy metrics compared for two payoff functions</i>	244
<i>Figure 62 Tests on entropy measures</i>	248
<i>Figure 63 The information content contributed to InitiatorEntropy by one agent</i>	249
<i>Figure 64 Total entropy given one agent with probability of selection x, and the other 19 agents with even probability</i>	251
<i>Figure 65 The Maverick Scenario illustrated</i>	257
<i>Figure 66 The Boundary Spanner Scenario illustrated</i>	258
<i>Figure 67 Results of Maverick and Boundary Spanner Scenarios for the agent-energy model</i>	260
<i>Figure 68 Results of Boundary Spanner Scenarios for a model with AgentE and the feature-energy model</i>	263
<i>Figure 69 Results of Boundary Spanner Scenarios for a model with IR Memory and the IRAM</i>	264
<i>Figure 70 Comparing the 1 energiser/de-energiser with the other 19 agents</i>	275
<i>Figure 71 Data on kills by German World War II flying aces</i>	293
<i>Figure 72 The Axelrod Cultural Model under a system-dynamics approach</i>	298
<i>Figure 73 The Axelrod Cultural Model ($q=2$) under a system-dynamics approach, with stochastic imbalance between directions of imitation</i>	300
<i>Figure 74 Another SD ACM ($q=4$) with stochastic element</i>	300
<i>Figure 75 Output from a version of the Axelrod Cultural Model as agent-based model and system dynamics models</i>	301

List of tables

<i>Table 1 Empirical sources for our energy concepts</i>	97
<i>Table 2 Energy Payoff calculations explained</i>	163
<i>Table 3 Tests scoring for Claims 1 and 2</i>	206
<i>Table 4 Tests scoring for Claim 3</i>	211
<i>Table 5 Approximate parameter ranges where claims tests held</i>	213
<i>Table 6 Initial Probabilities of Interaction Outcomes</i>	220
<i>Table 7 Approximate parameter ranges where claims tests held</i>	225
<i>Table 8 Entropy metrics explained</i>	241
<i>Table 9 IRAM scenarios explained</i>	242
<i>Table 10 Approximate parameter ranges where claims tests held (IRAM and IR Memory model)</i>	253
<i>Table 11 Approximate parameter ranges where claims tests held</i>	275
<i>Table 12 Strengths and limitations of the models and experiments</i>	281
<i>Table 13 Agent-energy model scenarios explained</i>	306
<i>Table 14 Scoring for tests of claims 1 and 2</i>	316
<i>Table 15 Scoring for tests of claim 3</i>	318
<i>Table 16 Feature-energy model scenarios explained</i>	319
<i>Table 17 IRAM scenarios explained</i>	326

Acknowledgements

This PhD could not have been attempted without financial support: a scholarship and bursary from Warwick Business School; another bursary from the ORMS group at Warwick; and assistance in the final few months from my parents. Also vital in getting me to this stage were the various people whose references helped me into the next step of my career: Jenny Teichman, Douglas Hedley and Fraser Watts at Cambridge; Minhaj; and Paul Harper and Chris Potts at Southampton.

Within WBS various members of the doctoral programme provided sounding boards for ideas or just sympathy when needed, including Elvira, Blair, Antuela, Audrey, Sophie, Cristiana, Anni, Thanos, Claudia, Christina, Stavrianna, Charoula, Arben and Michael. Among the staff Katy Hoad, Kathy Kotiadis, Yasmin Merali and, of course, my supervisors, Professors Stewart Robinson and Ruth Davies, played important parts. During the PhD, presentations were given to the WBS Simulation Seminar, the OR Society Simulation Special Interest Group, the OR Society Conference 49, UK Social Networks Conferences 2007 and 2008, and the Spring Doctoral Conferences at Judge Business School, Cambridge and WBS. I am grateful for the responses from these various audiences, as I am for the comments from the examiners, Dr Duncan Robertson and Professor Jim Moffat.

In view of the work that is about to follow, I feel particularly aware of how much one depends upon the social network that is one's friends.

Thesis Summary

We present a family of simulation models of agents with energy from social interactions. We take the concept of “energy” from social network analysts Cross & Parker, from Collins’s micro-sociology of interaction rituals, and from the social psychologists Ryan & Deci’s studies on intrinsic motivation. We use simulation models as “tools for thinking” about what energy is, and how it relates to the take up of ideas, the formation of cultural groups and the performance of work. Our models also provide insight into phenomena from studies of “communities of practice”, social capital and computer models of networks. Baker & Quinn have also developed simulations of agents with energy, and so we offer a critique of those.

We develop our models as extensions of the Axelrod Cultural Model. Our family of energy models include those that ascribe “emotional energy” variously to individual agents, to agents’ individual attributes, and to agents’ memories of interactions rituals. Agents obtain energy payoffs from interactions based variously on their sense of autonomy, belongingness and competence.

We compare the behaviour of each model and choice of payoff function through experiments to test claims derived from Cross & Parker: namely that “energisers” cause greater take up of their ideas, cause larger cultural groups to form around them, and raise the problem-solving performance of the agent population. We demonstrate this first claim for several model scenarios, but fail to find scenarios where the second two hold. We then conduct experiments to relate the capabilities of energisers to tasks of: disseminating ideas to otherwise homogeneous groups, and; spanning boundaries across cultural divides between groups. In all experiments we find two factors play critical roles in determining the diffusion and homogenisation of culture: the decay of energy charges on memories, and; the initial number of cultural traits in the population.

Abbreviations

ACM	- Axelrod Cultural Model
AgentE	- Agent-energy model
FeatureE	- Feature-energy model
IRAM	- Interaction Ritual Agents Model
IRM model	- Interaction Ritual Memory model

Chapter 1 Understanding how work really gets done in organisations

“In every branch of life - action, philosophy, organisation, technology - there was an extraordinary outpouring of energy, an intensification of existence. Popes, emperors, kings, bishops, saints, scholars, philosophers were all larger than life, and the incidents of history... are great heroic dramas, or symbolic acts, that still stir our hearts. The evidence of this heroic energy, this confidence, this strength of will and intellect, is still visible to us.”

(Clark, K, 1969, p.33)

1.1 Introduction: Models of agents with energy

Energy can be a part of understanding how work gets done in organisations. Not physical energy, the phenomenon measured in calories, but something recognised and studied by sociologists and psychologists, and appearing often enough in everyday language for us to feel confident invoking it here. As we will describe in Chapter 2, psychologists record the concept as “feelings of energy”, “vitality”, and “energetic arousal”, and they relate it to one’s sense of autonomy, belongingness and competence, and one’s level of motivation or disposition to activity. Sociologists theorise about “emotional energy”, or “human energy” – “the basic stuff of social interaction”, and relate it to feelings of group solidarity. It still needs clarification, however, and it needs relating to other concepts to be of practical use in the study of

organisations. This thesis argues that experiments with computer simulation models can be used to perform these tasks. In particular, we will extend a well-known simulation model - the Axelrod Cultural Model (Axelrod, 1997a, chapter 7; 1997b) - with “energy” concepts drawn from the sociology and social psychology of interactions.

What the experiments will show are relations between energy on the one hand, and, on various other hands, the take up of new ideas or innovations, the formation of groups, and performance in the search for materially better (cheaper, fitter) ideas. Via such phenomena, it is argued, the theoretical construct of energy explains how ideas spread and motivate individual workers’ actions within organisations, and thereby helps explain the behaviour and performance of the organisations as wholes.

The way in which simulations are able to do this is as follows. We take a theory of the behaviour of certain entities – individual, human workers. Call this the micro-level theory. We reduce this behaviour to a few simple principles; then model it in computational terms. In particular, we model interactions between agents. What interactions occur depends on the attributes of the agents, including their energy levels. In the light of the interactions the attributes of those agents are updated by the computer. Aggregate properties of the population of agents are noted over the simulation run, including metrics that represent the relata mentioned in the previous paragraph: the take up of ideas; the formation of groups; the performance of a search for fitness. Variation in the aggregate properties is related back to variation in the parameters of the micro-level modelling, and also compared with expectations based

on empirical observation of real social organisations. In this way, theories of energy and organisation are tested for coherence.

In the rest of this chapter, we describe the background to studying organisations, we give the motivation for studying a concept called “energy”, and we indicate what is to follow in the remaining chapters of the thesis.

1.2 Understanding organisations: the role of Operational Research and simulation

Definitions of organisations vary (see, for example, Scott, 1981, chapter 1), but one textbook’s take on them would be that they involve at least four elements (Daft, 1998). They are:

- social;
- bounded;
- structured, and;
- goal-directed.

They involve people’s capabilities, activities and interactions. They have members, or participants, distinct from non-members and membership must be recognised and maintained. The members are structured in various ways, both normatively – in terms of departments and teams, rules and regulations, and roles and reporting relations – and behaviourally – in terms of what people actually do, and who they actually

interact with (Scott, 1981, p.14). Structuring people's activities seems almost a synonym for "organising". That organisations are goal-directed is a little more controversial. Individual people have personal goals, but an organisation is not a person. One response to this would be to say we adopt an "intentional stance" (Dennett, 1987) – in trying to explain human activity we postulate there are human agents and ascribe to them intentions, including goals. In similar manner, if it be feasible and useful to ascribe goals to some active entity called an organisation, then that is all we need. The appearance of goal-directed behaviour by the organisation may well be the emergent result of interactions between individuals with their own goals (Cyert & March, 1963/1992, p. 28). Suffice to say that organisations involve goals.

Recognition of these four elements guides us towards some of the main issues within organisations:

- social interaction;
- membership;
- structuring, and;
- coordination.

This thesis touches upon theories of how social interaction causes individuals to act like they are members, to maintain particular roles and social structures, to develop and disseminate new ideas and practices, and to perform work collectively to a level greater than that they might perform in isolation from each other or without coordination.

There are other issues for organisations – such as resource allocation, and decisions concerning the consumption and production of goods and services – but the social aspect – human resources and the impact of their interactions – stands out as the most important.

In so far as managers can make decisions about organisations – about their structure, regulations, resource allocation, size, etc. – we may seek advanced analytical methods to help in this process. According to the Institute for Operations Research and the Management Sciences, “operations research (O.R.) is the discipline of applying advanced analytical methods to help make better decisions” (INFORMS, n.d.). Two areas related to studying organisations have been identified within management science (Burton & Obel, 2001). In the first, organisational theory, it is a descriptive or positive science, aiming at explanations of the structure, behaviour and effectiveness of an organisation. In the second, organisational design, the aim is a prescriptive science, creating and constructing more effective and efficient organisations. In Chapter 5 we will argue for an “interpretivist” or hermeneutic paradigm of OR based on facilitating group discussion and promoting understanding - so-called “Soft OR” (Dando & Bennett, 1981; Mingers, 1992; Robinson, 2001). For now we can accept that, either way, the study of organisations belongs within a management scientist’s remit.

The foundations of this subject are mostly provided by three texts - (Simon, 1948/1976); (March & Simon, 1958); and (Cyert & March, 1963/1992) – originally published between 1948 and 1963, and to which we might refer as “the Carnegie

School”, after the authors’ then affiliation. Collectively, these texts have proved their importance through inspiring a variety of development paths (Argote & Greve, 2007; Augier & March, 2008) and being cited many times, including by other well-cited papers (Gavetti et al, 2007). Against the convention by economists of the time of treating human agents as being perfectly rational in their decision making, March & Simon (1958) argued that agents have bounds on their rationality, brought about by the limited capacity of humans to process information and the limited information available to them to support those decisions. Instead of attempting to maximise their expected utility, boundedly rational agents satisfice, or seek only the first solution that satisfies some criterion. In addition, such searches for solutions are not the main type of activity. Most activity in organisation is routine following of “performance programs” (March & Simon, 1958, p.141) or “standard operating procedures” (Cyert & March, 1963/1992). Through comparisons with past experiences and those outside the organisation, agents maintain sets of aspirations and expectations. When those are suddenly no longer being met, searches are initiated for new solutions. Routines exist for performing these searches – heuristics – while the resulting solutions may become routine themselves through repeated use.

In responding to exceptional events and performing searches organisations are processing information. The greater the complexity of their environment, the more information will need to be processed. As Galbraith (1974) pointed out, variations in organisational form can be traced to differences in the level of task complexity, and differences in the ways organisations have chosen to respond to their processing needs. The bounded rationality of agents means that improvements on the individual’s performance must be sought through collaboration and coordination, which places

focus on the organisational structure and the ways in which conflicts between individuals' goals are resolved. This had led to the study of organisation in the light of theories of cognition (Lant & Shapira, 2001), and computation (Burton & Obel, 1995 eds.; 2001), as well as supporting interest in the role of social interactions. The working hypothesis is that some organisational designs (structures and practices), through their information-processing capabilities, are more efficient and effective and make for longer-lasting, more robust organisations.

The Carnegie School also made contributions to the methodology behind studying organisations. If organisations consisted in processes – the routine programs performed by human agents – then organisations could be studied via the empirical observation of those processes. This contrasted with treating the organisation as an agent in itself. Cyert & March (1963/1992) “aimed to open up the ‘black box’ of the internal workings of organisations” (Argote & Greve, 2007, p.344). Through this focus it helped legitimise qualitative research on what people actually do within organisations (Argote & Greve, 2007). A process-oriented view also encouraged the use of simulation models to study organisations – the first example of which appeared in Cyert & March (1963/1992). It took until the 1980s for this approach to take off (Carley & Wallace, 1995) – presumably contingent on the availability of computer resources – but today there are journals dedicated to formal models of sociological phenomena and organisations, including *Computational & Mathematical Organization Theory*, the *Journal of Mathematical Sociology*, and the *Journal of Artificial Societies & Social Simulation*. Thus from the Carnegie School's works onwards, both qualitative studies and formal modelling of what people do and how

they relate to each other became part of studying organisations. This thesis builds upon the fruits of both approaches.

1.3 Groups, boundaries and the take-up of innovations

Since the work of the Carnegie School, it has been accepted that organisations process information. They innovate, or seek solutions to new problems, and having been discovered, the solutions then must diffuse through the organisation to where they are needed. Three distinct approaches to the study of organisations – ethnography, social network analysis and simulation modelling – have revealed that the effectiveness of innovation and diffusion are greatly influenced by social groups and human factors in motivation and the take up of new ideas.

1.3.1 Ethnography

Perhaps the most significant of the three approaches so far has been ethnography. It is sometimes claimed that ethnography reveals a view of the organisation – as an interpretive system – contrary to the computational one assumed by other researchers (Lant & Shapira, 2001, p.2-6). The latter focuses on information as abstract, but communicable in textual documentation, whether on paper or electronic. The ethnographic studies at Xerox summarised by Brown and Duguid (1991; 2000) highlighted that official training initiatives assumed just such a view of information. Problem solving was also reduced to abstract form as the mechanical following through of decision trees in manuals. If correct, such an activity could be performed

by a lone technician or representative. The reality, however, was that problem solving occurred after social interaction, especially when reps working together engaged in story-telling. Through repeated attempts to describe a problem (in Xerox's case, a client's faulty photocopier) two co-workers converged on an interpretative narrative that led to a solution. A successful story then formed conversational capital when reps socialised back in the corporate canteen. Training, in the sense of building up the capital for future problem-solving narratives, occurred either on the job or through these social interactions, such as over the canteen breakfast table. The social group of reps represented a "community of practice", united by their engaging in the social practices of a rep rather than by knowledge of some abstract list of statements learnt in training or as a job description. Induction into the community of practice required becoming socially accepted, including observing and negotiating social status relations. Social relations built up this way with people across the company could then be tapped for assistance when reps were on the client's site. Thus ethnographic studies brought to managerial attention the dependence of the information-processing organisation on informal social life, especially social *groups*.

1.3.2 Social Network Analysis

Following a quantitative approach to research social network analysis (SNA) can also reveal a counter-intuitive view of "how work *really* gets done in organisations" (Cross & Parker, 2004b, chapter 1). Using questionnaires, and supporting them with interviews, analysts gather data on who really talks to whom or works with whom. Such tacit relations can be quite distinct from official reporting relations, and the relations implied by official organisation charts (for example, Cross & Parker, 2004b,

figure 1-1). Network concepts have been applied to organisations for decades (Tichy et al, 1979), and a variety of statistical techniques developed to interpret the results (Wasserman & Faust, 1994; Borgatti & Jones, 1998; Scott, 2000; Carrington et al, 2005). The number of social links a person has (“degree centrality”) indicates whether the person is a social hub or a peripheral figure in the organisation. Geodesics, or the shortest path of links separating two nodes, indicate the minimum number of connections required to convey information from the one person to the other (“degrees of separation”). A low average across a person’s degrees of separation may indicate a person is well-connected for information transfer within the organisation (high “closeness centrality”), while a low average across all pairs of nodes in the organisation suggests easy flow of information for everyone. Another centrality measure – “betweenness centrality” indicates how many geodesics include a particular node. If some people are only connected via a particular node, that node can perform the role of a gatekeeper, controlling who has access to which resources or information. Such individuals appear in networks that are clustered, in which subgroups of the nodes can be identified. Within clusters connections are relatively dense, but between clusters there are few connections. Such clustering may indicate divisions by department, hierarchical level, job type, geographic location, or just informal social cliques.

Clustering plays an important role in innovation and the spread of information. Within clusters the high level of transitivity in relations – that is, the large number of relations connecting nodes who are already connected indirectly by a common neighbour – results in a high degree of sharing of information. Ideas and practices known to one are readily passed around. Attempts to defect from this social consensus are swiftly

detected by neighbours and a return to the consensus encouraged. Following Coleman (1990) some argue that individuals within a cluster enjoy a high degree of *social capital*, since they can trust those around them to share their values and behave in expected ways (Putnam, 2000). But innovators within the cluster will see little reward from their peers for deviating from convention, and their innovations have little chance of being taken up by the group. New ideas typically enter the group via people who belong to more than one group (“boundary spanners”) and can broker information flow between the clusters. Organisational performance through innovation depends on the “structural holes” between groups being filled by these brokers (Burt, 1992; 2005). Granovetter’s pioneering research demonstrated that information for job seeking typically arrived via relatively weak social ties from other social cliques (Granovetter, 1974).

Gaps have also been identified between communities of practice in qualitative research. Studies in the healthcare sector noted knowledge failed to spread between people of different professions, a problem likely to affect other multi-professional organisations (Ferlie et al, 2005; Dopson & Fitzgerald eds, 2005, chapter 6), or any organisation where researchers and practitioners are distinct (Dopson & Fitzgerald eds, 2005, chapter 3). This is the problem of “stickiness” (Brown & Duguid, 2001). Knowledge “sticks where practice is not shared”. A firm’s competitive advantage lies in coordinating the knowledge produced by its distinct communities. Working side-by-side and having common organisational values help knowledge transfer between professional groups (Tagliaventi & Mattarelli, 2006). But knowledge “leaks in the direction of shared practice” (Brown & Duguid, 2001) – even if the people sharing practices are employed by separate companies. Thus discoveries made in one

organisation may fail to be taken up within that organisation, yet go on to be adopted by competitors. With “networks of practice” crossing organisational boundaries some have found it “ever more difficult to think of ‘organisations’ as stable entities with defined boundaries” (Easterby-Smith et al, 2000). For the manager they present a need for trade-offs between on the one hand promoting the learning of practices that comes through social relations with those sharing practices, and on the other hand promoting innovation.

1.3.3 Computer models

Evidence from computer models also supports the idea of trade offs. March’s model of organisational learning (March, 1991) demonstrated the need for a trade off between exploration for new ideas and exploitation of current beliefs in maximising organisational knowledge. Heuristic search algorithms such as Genetic Algorithms (Mitchell, 1996) require a decision about the innovation - or mutation - rate for a given problem. Too much mutation and good solutions will be corrupted before they can spread. Too little and there will be no new solutions. Social network evolution models also include tuneable parameters, such as a number of randomly rewired links, and the preference when linking for similar others (homophily) or others affiliated to the same cultural groups (Watts, 2004). These parameters can influence the average path length between nodes, the degrees of clustering and modularity, and the searchability of the network. Carley’s simulation models of organisational decision making have tested different organisation structures containing decision makers of various levels of cognition (Carley, 1996; Carley & Lin, 1997). It would seem that cognitive and organisational complexity levels can also be traded off.

We will examine more examples in Chapter 3. For now we note computer simulation models join a number of research approaches indicating that groups interact with innovation processes and transmission or diffusion processes to determine problem-solving performance in organisations and social networks. In the cases of preference for similarity, and rates of exploration and exploitation there can be too much or too little. Can there be a common medium in which processes of group formation, innovation and motivation are traded off and an optimal balance sought? This thesis explores the possibility that the missing component is something called “energy”.

1.4 Cross and Parker’s three claims about energisers

In recent work on “how work really gets done in organisations”, Rob Cross and Andrew Parker discuss a new concept in social network analysis (Cross & Parker, 2004b). In addition to collecting data on information flow and who collaborates with whom (Cross & Parker, 2004b, chapter 2), and who is aware of who knows what and who has access to help from whom (Cross & Parker, 2004b, chapter 3), they started collecting a new type of relation data, roughly, who energises whom and who de-energises whom (Cross & Parker, 2004b, chapter 4; Cross & Parker, 2004a).

This concept of energy links in with innovation and its take up. One of their case studies yielded the following quote:

“The surest way an innovation or any good idea will die here is if it is developed in isolation. Nothing innovative happens without someone getting

fired up about an idea and then getting others enthused about and supportive of their plan... no matter how good or technically right the idea might be. If you can't generate energy for a new idea nothing of substance ever really happens." (Director R&D, Consumer Products Organisation. Quoted in Linder et al, 2006, p.26)

That is, being a good idea is not enough. For the idea to become action the innovator must become excited by it, and must be able to communicate not just the idea, but that excitement to others. Some people are better than others at generating this enthusiasm, or energy.

Other people sap it. Confronted with a new proposal they "tend to be more negative, focussing on all the reasons why you can't do something" (Baker, 2004). We dread meeting with these people, avoid them when possible, spend time rehearsing how to cope when avoidance is not possible, and seek out others afterwards to whom we can vent our feelings or get recharged by. Thus, the presence of de-energisers affects even those they are not directly connected to. Every organisation has people who are energisers or de-energisers of others (Cross et al, 2003a).

Working with other researchers, especially Wayne Baker, Cross and Parker conducted interviews to find out what creates energy in an interaction. They list behaviour during the interaction (such as the responses to proposed ideas mentioned above), the characteristics of the participants and the relationship between them (for example, interactions with an mistrusted person de-energise) (Cross et al, 2003a), and inspiring or enabling the following (Cross & Parker, 2004a):

- a compelling vision;
- a meaningful contribution;
- full engagement in the interaction (as evidenced by body language or how easily one lets oneself be distracted);
- a sense of progress;
- belief in the goal.

Such things might seem desirable in an organisational setting. Using the data collected on energising and de-energising relations, Baker et al (2003) compared in-degree centrality in the energy networks - that is, the number of respondents claiming one energised them - with annual human-resource performance ratings. Energisers were better performers, “even after controlling for information processing variables, structural holes, and other variables” (Baker et al, 2003, p.339).

A number of claims are made to explain this association with performance (Cross et al, 2003a, p.52-3). Firstly, motivation and the take up of ideas: energisers are “more likely to have their ideas considered and put into action. They motivate others to act...” Energisers “get more from those around them... [P]eople devote themselves more fully to interactions with an energiser, giving undivided attention in a meeting or problem-solving session. They are also more likely to devote discretionary time to an energiser’s concerns.” Energisers gain reputations, and people are more likely to seek interaction with and information from an energiser than a de-energiser. This may account for the performance of those strongly connected to energisers being better as well. De-energisers can have expertise to offer a group as well, but their ideas go

untapped, and in frustration their repeated attempts to gain attention can disrupt a group. A plausible model of energy in organisations should be able to verify some of these claims.

In their summary, then, “energy in organisation matters for performance, morale, innovation and learning – people understand this intuitively and our research confirms it.” (Cross et al, 2003a, p.56). But they also admit - as did one of their interviewees - that the “energy” concept sounds “like a New Age idea” (Cross & Parker, 2004a, p.3; 2004b, p.49). They have grounded it in their empirical research, but how seriously might other researchers take it? As well as the book (Cross & Parker, 2004b), their energy work has appeared in book chapters (Baker et al, 2003), non-journal reports (Cross et al, 2003b; 2006), and the *Sloan Management Review* (Cross et al, 2003a), *Business Strategy Review* (Linder et al, 2006) and the *Journal of Organizational Excellence* (Cross & Parker, 2004a). For better connection to the rest of organisational studies we must follow some of their references. In particular, they refer us to energy-like concepts in sociology (e.g. Collins, 1993), social psychology (Ryan & Frederick, 1997) and psychology (Thayer, 1989), as well as “Positive Organisational Scholarship” (Quinn & Dutton, 2005). Chapter 2 examines this literature to tackle the question of what energy is. In particular, Randall Collins’s sociological theory of interaction ritual chains will link a sociologist’s concept, “emotional energy”, to social interaction, group membership and the performance of routine cultural practices or rituals.

While the social network analysis of energising relations may be relatively new, the referred-to concepts in sociology and social psychology, in particular, are well

grounded in their respective fields. Sociologist Randall Collins's work draws upon the theories and methods of Durkheim, Weber, Goffman and Garfinkel, as well as more recent literature on the sociology of intellectuals, the family, and violence, among other topics (Collins, 1998; 1992; 2004; 2008). As well as having an extensive command of secondary literature, he surveys data on so-called micro-situations – occurrences of social interaction rituals, as recorded in photographs, videos, first-hand accounts, and frequency counts of events. His research is now cited by other sociologists (e.g. Fuchs, 1993), social network analysts (Burt, 2004) and in organisational studies (Goss, 2007; 2008). Social psychologists Edward L. Deci and Richard M. Ryan base their research into “intrinsic motivation” primarily on psychological laboratory experiments, as well as observations made in classrooms and workplaces (Ryan & Deci, 2000; Deci & Flaste, 1996). Their concepts and methods are now part of a flourishing field, self-determination theory (Deci & Ryan, 2002). Cross and Parker themselves have collaborators working with the “energiser” or “energy” concepts, and the way is open for other researchers to perform social network analyses based on energising relations, as Reinke (2005) does.

1.5 Other approaches

“Energy”, of course, is not the only way to study the phenomena of motivation, social interactions and groups in work organisations, so a few remarks are called for on why we choose not to focus attention on other approaches. Instead of measuring interactions between people, many psychometric tests record personality traits. An instrument such as the Myers-Briggs Type Indicator is then employed in “managing others, development of leadership skills, organizing tasks, creation and management

of teams, training for management and staff, conflict resolution, motivation, executive coaching, diversity, recognition and rewards, and change management.” (The Myers & Briggs Foundation, 2009) But the common assumption behind these that people can be categorised into one of a small number of personality types which change neither with time nor with context is questionable, yet carries a lot of importance in view of recruitment and team selection decisions being made using the instruments. By contrast, we will focus on cultural attributes of people, which may change with social interaction and learning. The value of expressing these attributes in actions will vary with people’s social environment.

What a person can acquire from a social situation is stressed by the well-regarded social psychological theory of self categorisation (Turner, 1991). According to this, a person chooses between group memberships as part of the process of constructing his or her self identity. Because of this, group identities become one of the main forms of social influence on people. Collins also stresses the social process of constructing a self, and future research should try to match up his sociological theory to the social psychological one. We cannot cover self categorisation theory in this thesis alongside the work on energising, but we will present models of social influence in which a human agent acquires the culture of a group.

We also neglect the phenomenon of group or team formation through conscious selection of participants by some decision maker, such as to pursue some task or goal. Such intentional group formation raises the tricky question of whether the individuals are really pursuing the group’s official purpose rather than their own, varied individual goals. Indeed, a set of individuals may cluster together in a network of

different relations, without there being some attribute that they all have in common to designate this group by. The situation is complicated further by the phenomenon of surreptitious disobedience: workers may pay lip service to their supervisors' orders in public, while agreeing amongst themselves to subvert those orders once supervision is over. We suspect that such a mixture of “frontstage” and “backstage” performances (Goffman, 1959) would make for a rather ambitious model at this stage.

Also difficult for the modeller may be the reproduction of the phenomena of group dynamics. Some researchers have identified different stages in the behaviour of groups. Tuckman (1965) proposed a well-known set: “forming”, “storming”, “norming” and “performing”. We do not try to identify stages in the behaviour of our models, but their behaviour certainly evolves and future research may try to match this up with that of real groups, in which case the micro-level theories of social interaction underpinning the models would offer explanation of the emergent, group-level phenomena.

Our focus is on processes of social emergence (Sawyer, 2005) – the evolution of groups through the social interaction, action and cultural evolution of their members, who in turn react to the changing social environment. Energy will form a part of this dynamic system. We think computer simulation models can serve to develop this concept, something that might be more difficult with some of the alternative approaches listed above.

1.6 The aim and organisation of the thesis

The aim of this thesis is to develop models of energy from social interaction, including explaining what energisers are. We have seen in this chapter how organisational studies pursued via ethnography, social network analysis and computer modelling have pointed to social interaction being critical to motivation and the take-up of ideas, to group formation and to work performance in organisations. We propose simulation modelling of energy and energisers as a means to clarify and unify how these concepts relate to each other.

The literature review falls into two parts. In Chapter 2 we discuss what might be meant by “energy”. Various psychological and sociological studies involve energy-like concepts, and we find it hard to equate them. However, Collins’s “emotional energy” serves our purposes well, given our desire to relate energy to motivation and groups, and Deci and Ryan’s work on intrinsic motivation and the need for autonomy, belongingness and competence can be construed in such a way that it fits in with Collins’s theory. Having indicated what we would like to model, Chapter 3 examines previous approaches to modelling social agents, including their attributes, environment and interactions. With one exception, no one has attempted to base a comparable model on Collins’s or Deci & Ryan’s work.

The one exception is discussed in Chapter 4 – Baker & Quinn’s model of agents with energy and information (Baker & Quinn, 2007). We take issue with features of the model and with their use of it, but the resulting discussion illustrates important points on methodology. In Chapter 5 we argue for our own methodological paradigm, and explain why simulation modelling can serve it, and how agent-based modelling is particularly suitable.

Chapter 6 introduces the model – or family of models, for we build up our model in stages, with Axelrod’s model of cultural influence (Axelrod, 1997a, chapter 7; 1997b) as a baseline, giving us roughly three main groups of models. A payoff function based on autonomy, belongingness and competence is explained, as is the representation of what we need to test three claims derived from Cross and Parker’s work: the take-up of ideas, the formation of groups, and some sort of problem-solving performance measure. Finally we describe the series of experiments performed with the various models, and some of the visual displays produced by the models that help with building credibility for the models (Chapter 7).

The next three chapters present the results of experiments on the respective types of model: those applying energy to agents (Chapter 8); those applying to agents’ cultural features (Chapter 9), or attributes, and; those applying it to agents’ memories of complete interaction events (Chapter 10). Then in Chapter 11 we relate our models to the spread of ideas, via experiments that compare energisers with the concept of “boundary spanners” from the social capital literature.

Chapter 12 reviews our experiences in modelling and experimentation to conclude on the extent to which we have clarified and unified the concepts of energy and energisers. Strengths and weaknesses of the modelling approach are detailed, and suggestions made for further research.

Appendix A reflects on the possibility of using system dynamics modelling instead of an agent-based approach. It supports the choice of the latter made in section 5.7, but

assumes knowledge of the agent-energy model described in Chapter 6 and its behaviour shown in Chapter 8. The next four appendices collate for convenience experimental results discussed in Chapter 8, Chapter 9 and Chapter 10, the last of these chapters covering sufficient results for two appendices. Appendix F is a much extended version of a discussion from section 12.5.3, in which we draw analogies between the energy models and various heuristic search algorithms used for optimisation problems. In particular, it is asked whether the problem-solving properties of such models may tell us anything about what it is for real-world agents to solve problems socially.

Agent-based simulation models cannot represent the real world in all its detail - but we argue they can shape our thinking about the sociological phenomena of motivation, the dissemination of ideas, culture, group formation and problem solving in organisations. By focussing on a unifying concept - that of energy - this thesis is intended to illustrate how.

Chapter 2 What is “energy”?

2.1 Introduction and context

In Chapter 1 we saw how Cross and Parker have introduced a notion of energy from social interactions, and have made certain claims about “energisers” and “de-energisers” in organisations. In this chapter we explore the concept of energy in the literature. Both Cross & Parker’s work (Cross & Parker, 2004b) and that of collaborators Wayne Baker and Ryan Quinn (Baker & Quinn, 2007, p.5; Quinn, 2007, p.73) refer readers to works by psychologists, social psychologists and sociologists to support the concept of energy. We examine the support for treating all these authors as if they are working on the same concept, before identifying reasons for distinguishing between them. There seems scope for conflict between studies of an energy concept derived from psychology and sociologists’ explanations involving “emotional energy”. Such theorists’ conflicts have implications for attempts to employ one or more of these concepts. We conclude with a proposed model that incorporates some of the best ideas from the literature in such a way that Cross and Parker’s claims about energisers can be explored further. In particular we bring together social psychologists Deci and Ryan’s emphasis on feelings of autonomy, belongingness and competence during social interactions (Ryan & Deci, 2000) with sociologist Randall Collins’s theory of interaction ritual chains (Collins, 2004).

It is worth remarking on the context of the work by Cross, Parker, Baker and Quinn. Baker et al (2003) bring the tools and techniques of social network analysis to a new

research programme, “Positive Organisational Scholarship” (Cameron et al, 2003), itself an attempt to apply results from “Positive Psychology” to organisational studies. Attempts to link psychology to work and organisation, especially via motivation, have a long history (Vroom & Deci, 1992). But the last few decades have seen growing interest in so-called “positive” phenomena, such as happiness, wisdom and psychological health or well-being – in contrast to the post-world-war-two focus on mental disorders, pathologies or *malfunctioning* (Peterson & Seligman, 2003, p.14-16). Key features of this programme for those interested in a concept of energy include the measurement of feelings or moods using self-report questionnaires (section 2.7), and the notion of *intrinsic* motivation – in contrast to the application of *extrinsic*, reward-and-punishment motivation. Extrinsic rewards can raise activity levels while they are being applied, but once removed the disposition to perform the activity falls below the level shown before the extrinsic motivation was applied. That is, use of extrinsic motivation reduces intrinsic motivation, the motivation to perform an activity for its own sake. (Deci & Flaste, 1996) In the case of intrinsic motivation one commentator (Kohn, 1993, appendix 3) finds the worlds of management and education to be particularly resistant to the new thinking. There is still considerable attachment to the idea of raising people’s motivation – and thereby their production – by *bribing them*, a throwback to Skinner’s behaviourist psychology (Kohn, 1993, chapter 1), but also to the machine-like image of human workers underlying Taylor’s “scientific management” (Grey, 2005, p.34-42). If common-sense thinking on motivation can be revised, however, the implications for day-to-day actions on the part of managers and teachers could be considerable. We might summarise the position thus: the question “how do I motivate my employees?” is misguided; instead ask “how do I create the circumstances in which they motivate themselves?” That is,

organisational performance can be best raised by facilitating the linking up of members' interests (as they see them, not as the manager imagines them) to members' circumstances (that is, what opportunities the environment provides). Models of "how work *really* gets done in organisations", then, would seem to need to incorporate this distinction between intrinsic and extrinsic motivation. A very recent survey suggests economists are now aware of this distinction (Bowles, 2008, p.1607), though we might wonder why it has taken so long.

The other major reference point for Cross, Parker, Baker and Quinn is Collins's theoretical sociology and its notion of "emotional energy". This has its origins in Durkheim's work on rituals and the sociology of religion, and in Goffman's work on interaction rituals (Collins, 2004, chapter 1), but it also refers to the fruits of Garfinkel's ethnomethodology and Weberian conflict theory. The overall impression is of an attempt to depict a very inclusive body of sociological theory, building up over a century and a half. Collins has applied his theory in explanations of patterns in the social networks of philosophers and intellectuals (Collins, 1998), violence in battle and in the streets (Collins, 2008), crime (Collins, 1992, chapter 4), education (Collins, 1979), sexual behaviour, political stratification and smoking behaviour (Collins, 2004, chapters 6, 7, 8 respectively). With such a background and such applications, it would be highly desirable to link up with this theory.

We find below, however, that equating such theorists' concepts as "intrinsic motivation" and "emotional energy" is not as straight-forward as it might seem.

2.2 What energy is not: Physics and Physiology

A science-literate readership may be wondering whether there is a connection, or at least an analogy, to the concept of energy found in natural sciences, such as what one has when running (kinetic energy), or what one obtains from eating carbohydrates (chemical energy). The pioneers of statistical mechanics were both inspired by social scientists such as Adam Smith and Henry Thomas Buckle, and in turn inspired the pioneers of calculus-based methods in economics (Ball, 2002; 2006; Heilbroner, 1992), but we find no useful analogies between, say, kinetic energy and the psychologists and sociologists' concepts described below. Physicists had to distinguish kinetic and potential energy from related concepts, including force, power and momentum. To draw analogy with one of these concepts is to invite demands for psychological or sociological analogues to the others. Without such relations, it is hard to see how an analogy with physical energy helps elucidate the concept we are interested in.

One principle emerging from physics is that energy cannot be created or destroyed. Instead it is converted between different forms. By contrast Marks's survey of the sociological uses of "human energy" identified two images: the "scarcity" and "expansion" approaches. (Marks, 1977, p.921) In the former, energy is something that can be used up when we act, and being a scarce resource must be allocated to competing roles, such as family and work, or Freud's pair of "civilisation-building" and "erotic" activity. The expansion approach, stemming from Durkheim, sees energy as something generated by performances of social interactions, not consumed. In

neither approach by sociologists, then, is there the idea that human energy is being converted to or from other forms, or being conserved.

The Greek origins of the word - “energeia” - refer to “activity”, “act” or “functioning” (Peters, 1967, p.55-56). Autonomous, or self-caused, motion is what demarks matter as having a soul or life (see “Psyche” in Peters, 1967), so energeia – via activity - is related to vitality. In contrast with “kinesis”, however, “energeia” was not directed towards some goal or end. For modern psychologists of work, energy is still related to activity, but is combined with goals, or objectives, to make up motivation, and form the correlate of levels of activity (Vroom & Deci, 1992). As Marks points out (Marks, 1977, p.925-6), human activity does consume an energy-related resource. Adenosine triphosphate (ATP) is consumed when muscle fibres contract. But the production of ATP is stimulated by the body through ATP-consuming muscle contractions. Activity thus both requires a source of (chemical) energy, and is necessary to stabilise production of this energy. “[E]ven while we are spending it we are also converting more of it for later use.” Under normal conditions of daily activity, when humans are well-nourished and relatively free from stress, “the energy potential of the body at any given moment is physiologically abundant rather than scarce.” (Marks, 1977, p.926) So the facts of physiology will not ground the scarcity approach to energy.

It seems better, then, to accept that any similarities in the past to application of energy-words in physical and physiological explanations are no longer of help to us. Our sources are intending something distinct, and it is time to examine how psychologists and sociologists use the terms.

2.3 A unified concept?: feelings of energy

In psychology-inspired literature “energy” is related to feeling and to action - often a feeling about action. For example, Quinn and Dutton define energy as “the feeling that one is eager to act and capable of acting” (Quinn & Dutton, 2005, p.36). We find, however, some authors do not repeat this formula.

Cross and Parker describe being introduced to the concept of “energy” by a “managing partner at a strategy consulting firm” (Cross and Parker, 2004a, p.3). It was “buzz” and an “enthusiasm for things”. “Buzz” is firstly something one hears - perhaps because a positive impression on people has led them to want to comment about it amongst themselves - but it can also be described as something one feels. “Enthusiasm” likewise is more commonly shown rather than felt. Given their past collaboration with Baker, and Baker’s collaboration with Quinn, it seems unlikely that they intend distinct concepts here. It is just a feature of (English) language that we refer to private experiences, or feelings, by using words with connotations to publicly observable manifestations of those private experiences.

More confusing, however, is the language of mood or affect in psychology, which seems to distinguish what is felt from what is manifested in action. Quinn defines energy as “a dimension of affective experience” (Quinn, 2007, p.73), where “affect is a label for subjective physiological experiences people have, including short-term, targeted emotions; longer-term, less targeted moods; and enduring dispositions”. This would tally with Thayer’s notion of “energetic arousal” as a mood system “extending from the biochemical and cellular levels of function to activation of various

subsystems of the brain, and finally to conscious awareness” (Thayer, 1989, p.6). The evidence for such a system is best at the “highest level” of integration – “the awareness of bodily sensations and of related subjective feelings” – so most attention is focussed on it. But alongside “energetic arousal” Thayer describes another mood system: “tense arousal”. These are distinct in how we experience them. “Energetic arousal” is recognisable by “subjective sensations of energy, vigour, or peppiness”. “Tense arousal” is recognisable by “feelings of tension, anxiety, or fearfulness”. But Thayer then describes two kinds of “subjective energy in consciousness” - “tense-energy” and “calm-energy” (p.7) - with a complex relation between the two. “Moderate tension” – such as an upcoming deadline - can *raise* “energy feelings”, when, for example, an individual is motivated to get to work. “Substantial amounts of tension”, however, or “long-standing debilitating tension” cause *reduced* energy. Increasing energy often has a tension-reducing effect. There seems a distinction, here. On the one hand there is “sensations of energy”, a particular kind of positive mood. On the other hand there is “energy” as what one has when one acts – whether in response to positive or negative stimulus. “Energetic arousal” relates to “gross motor activity” (Thayer, 1989, p.50), but does “tense arousal” not relate to activity as well? Another ground for distinguishing them may lie in attention. When energetically aroused one focuses on the task in hand, which leads to increased efficiency. Those who are tensely aroused, however, focus on some external cause (Thayer, 1989, p.52).

Watson, Clark and Tellegen also postulate two types of mood: “Positive” and “Negative Affect” (Watson et al, 1988). Positive Affect (PA) “reflects the extent to which a person feels enthusiastic, active, and alert”. High PA is “a state of high energy, full concentration, and pleasurable engagement, whereas low PA is

characterised by sadness and lethargy.” Negative Affect (NA) is “a general dimension of subjective distress and unpleasurable engagement that subsumes a variety of aversive mood states, including anger, contempt, disgust, guilt, fear, and nervousness, with low NA being a state of calmness and serenity.” The two moods are not opposites (i.e. their measurements are not strongly negatively correlated), but they “can be meaningfully represented as orthogonal dimensions in factor analytic studies of affect”. Significantly for our purposes, PA, but not NA, “is related to social activity and satisfaction and to the frequency of pleasant events”. NA, but not PA, “is related to self-reported stress and (poor) coping, health complaints, and frequency of unpleasant events”. That the two moods are “not opposites” - when one relates to the frequency of “pleasant events” and the other to that of “unpleasant events” - seems surprising and would be worthy of further clarification in the literature. But that only one mood relates to social activity identifies it as the proper concern of our social network analysts.

2.4 Intrinsic motivation

Discussing what they call “subjective vitality”, Ryan and Frederick admit “clearly there are many states in which one experiences high energy that are not associated the positively toned feeling of vitality, and are probably also not associated with greater well-being” (Ryan & Frederick, 1997, p.559). Examples they give of such energetic but non-positive states are “mania, anger, hostility, and anxious agitation”. “Energy-related affects” like anger, anxiety, and jitteriness are not associated with positivity or with “being an ‘origin’”. Humans have a “basic psychological need to experience themselves as effective origins of action... – to initiate and regulate their own

behaviour” (Ryan & Frederick, 1997, p.534). Subjective vitality is felt when these needs are being met. To these needs for feelings of autonomy and competence, Ryan and Deci’s add a third need –that for feeling “related” to others (Ryan & Deci, 2000), or as Quinn puts it, a sense of “belonging” (Quinn, 2007, p.79).

Deci and Ryan measure motivation levels by quantity of activity - usually duration. Beginning with laboratory experiments, they identified a distinction between intrinsic and extrinsic motivation. Carrot-and-stick type approaches to motivating people produce increases in activity levels while applied. But when no longer applied, activity falls to a level lower than that before the application. Intrinsic motivation towards the activity has been destroyed. Deci and Ryan traced this effect to subjects’ feelings of autonomy, relatedness or belongingness, and competence. The choice of language and body language on the part of the experimenter could make a big difference to motivation levels, intrinsic and extrinsic. This distinction was reapplied to situations in classrooms and work places, with hugely important implications for education policies and working practices on the part of those in managerial positions (Deci & Flaste, 1996).

2.5 Emotional Energy in Interaction Rituals

In Collins’s theory “emotional energy” is not the symptom of a need, but what human agents have a need for. Collins admits his is “a rather undifferentiated term, that includes various components”, but the most important component is “very energy-like” (Collins, 1990, p.32). It forms a “continuum, ranging from a high end of confidence, enthusiasm, good self-feelings; down through a middle range of lesser

states, and to a low end of depression, lack of initiative, and negative self-feelings.” Both ends of this continuum are connected to social activity, representing the positive or negative outcome of interaction rituals (IRs). But Collins’s terminology can become a little confusing at times. He uses “emotional energy” to refer to “the feelings of attachment to the group that was assembled at the time”, to “group solidarity”, or the “feeling of status group membership” (Collins, 1990, p.32). Yet elsewhere he distinguishes “between two different emotional outcomes of an IR: the solidarity felt with the group... and the emotional charge... that the individual carries around with him- or herself for a time afterwards... which I call emotional energy...” (Collins, 1993, p. 211).

Emotional energy (EE) is a “rather general metaphor”. It is “readiness for action, which manifests itself in taking the initiative in particular sorts of social relationships or with particular persons.” (Collins, 1990, p.39-40) It is like the psychological concept of drive, but with a “specifically social orientation” (Collins, 1990, p.32). High EE is a “feeling of confidence and enthusiasm for social interaction... the personal side of having a great deal of Durkheimian ritual solidarity with a group”. Low EE is “a lack of Durkheimian solidarity. One is not attracted to the group; one is drained or depressed by it; one wants to avoid it. One does not have a good self in the group. And one is not attached to the group’s purposes and symbols, but alienated from them.” (Collins, 1990, p.32-3) Finally, emotional energy can also be explained as expectations. This leads to there being *specific qualities* of EE, as one can have expectations about specific situations (Collins, 1990, p.40). “Two major dimensions of stratification (power and status)” produce specific qualities of EE (Collins, 1990, p.33). Expecting “to dominate, or be dominated”, represents one’s EE in the power

dimension. Expecting “to be a central member, or a marginal one, or not be accepted at all” represents one’s EE in a group status dimension. These emotional energies tend also to be “specific to particular networks and groups, or particular kinds of them: some persons feel full of confidence and initiative in a party of professional acquaintances, but not in a sexual situation; some feel confidence in a business negotiation, but not a political one” (Collins, 1990, p.40).

This leads us to suggest that Collins’s term “emotional energy” is doing considerably more than “energetic arousal”, “positive affect”, and “subjective vitality”, even if one distinguishes from EE the notion of group solidarity. It lacks the counterparts of “tense arousal” and “negative affect”, but covers the motivation causing and caused by any emotional situation. “Which emotion is initially aroused is less important than the fact that group density, boundedness, and focus produces an increase in this emotion”. The emotion might be “sorrow (at a funeral), fear (in a disaster, on a battlefield, or at a political meeting focussed on an enemy), happiness (a common victory or a pleasurable occasion), surprise and humour (in an entertainment), enthusiasm and effort (in a collective project or among an audience cheering a team), or sexual arousal (usually in a very small group)” (Collins, 1993, p.208). Distinctions in EE come, not from the emotional moods, so much as the specific situations of the interaction rituals, and the cultural practices and objects present. Thus a model of agents with emotional energy – rather than one of the psychologists’ notions – would seem to require that culture be represented in the model in some way also.

2.6 Distinguishing concepts: Energisers and Energy Leaders

We saw in Chapter 1 that Cross and Parker argue part of “understanding how work *really* gets done in organisations” is identifying people who cause changes to other people’s energy levels: “energisers” and “de-energisers”.

Collins’s theory postulates that one person’s emotional moods spread to other participants during an interaction ritual. This allows for the existence of an “energy-leader, a person who stirs up contagious feelings when the group is together” (Collins, 1990, p.30). But creating this common mood makes them the focus of attention in the group, and brings with it an energy payoff to the instigator. This makes them more likely to play the instigator in future interactions. “In this way, powerful persons re-create their power from situation to situation, while those whom they dominate re-create the low energy level that makes them followers and subordinates.” (Collins, 2004, p.131)

Collins’s application of his concepts to the themes of social networks and creativity among intellectuals, and the production of violence in cities and in wars, makes clear the importance of a concept that explains stratification. According to his “laws of small numbers”, at any one time the number of people occupying points of focus of attention in philosophy is small (Collins, 1998, p.81-82). In the cases of violence in war and street violence (especially riots), a small number of people are responsible for most of the violent acts (Collins, 2008, chapter 10). These elites - the “energy stars” (Collins, 1998, p.420, 626; 2004, p.132) - are supported by others to varying degrees, the number of people providing a given level of support increasing with distance from the elite (Collins, 2008, chapter 11).

Where rituals exhibit the dimensions of stratification - power and status – energy-leaders become the order-givers and the central members of groups. In the business context they are “the business executive of the centre of a decision-making network, the busy professional, the skilled craftsman surrounded by advice seekers and apprentices, the salesman in a favourable marketplace.” (Collins, 1993, p.219) Because of their positions, these people can accumulate large stores of EE over time, which in turn makes them most likely to perform the same roles in the future.

But we note these high-energy people are not necessarily *energisers*. Indeed for some cultural practices a highly energetic performance by one person can *de-energise* others, or reduce the opportunities for others to gain energy, such as when others feel dominated or marginalised by the higher energy person seizing the initiative in rituals, and performing the role others expected to be theirs.

In some situations high-energy persons come close to the energiser concept. “Frequently, the positive emotions (joy, enthusiasm, humour) are generated by a group leader, an individual who takes the focus, who is able to propagate such a mood from their own stores of emotional energy. Thus this individual serves as a kind of battery for group emotional expressiveness. Persons who occupy this position in IR chains are what we think of as ‘charismatic’.” (Collins, 1990, p.42) But notice these individuals “take” the focus of the group’s attention, and thereby gain the most emotional energy from the interaction rituals. The others get energised by these encounters, but not as much as the group leader. In addition, the common emotional mood that the group converges on is that of the leader.

Energy leaders in Collins's theory - are not disinterested. They gain more from IRs. Nor are they automatically benevolent. Indeed, "energy stars" may on occasion not be energising at all. By being first, they frustrate others' attempts to instigate a common mood and attract the focus of attention of the group. By directing group attention to particular cultural practices or activities they may promote symbols that lack the same level of emotional significance for some members. If there are alternative IR opportunities - rival groups one can join, a "market for ritual solidarity" (Collins, 2004, chapter 4) - one can always consider avoiding a particular dominator. But such options are likely to be small in number, and may bring a worse risk of domination, leaving one stuck with the low energy returns of being dominated. The availability of alternative IR opportunities determines whether the energetic are also the energisers.

In one short article Baker actually draws a distinction between "a high-energy or charismatic person who generates what psychologists call high-arousal emotions in others" and the "energising behaviour" he wishes to focus on (Baker, 2004). The former notion seems to refer to those who cause arousal in others – the causes of the feelings measured by the psychologists discussed above. The latter notion is "about letting other people know they matter – for example, when someone comes into your office to speak with you, you devote your physical presence and undivided attention to that person. Even a shy person can be energising in this way." "The ability to energise isn't a function of personality; it has to do with the behaviours you exhibit in your interactions with others." (Baker, 2004)

2.7 How to measure energy?

The authors so far surveyed give several ways to measure energy concepts: self-report questionnaires and interviews; body language; tone of voice; physiological responses, such as pulse rate and sweating; activity levels, and speed to initiate actions.

Cross and Parker (2004b, p.51) used questionnaires to record energising and de-energising relations. Respondents were asked to evaluate their neighbours on a 5-point Likert scale:

“People can affect the energy and enthusiasm we have at work in various ways. Interactions with some people can leave you feeling drained while others can leave you feeling enthused about possibilities. When you interact with each person below, how does it typically affect your energy level?”

(Cross et al, 2006, p.9)

“1” means strongly de-energising, “5” means strongly energising. Clearly the first two sentences in this are intended to elicit a common concept from each respondent, by referring to “feeling enthused” and “feeling drained”. From these data they then distinguished “energising” and “de-energising” relations (i.e. responses of “4” or “5”, and “1” or “2”) and performed social network analysis on “energising networks” and “de-energising networks”. They combined this quantitative approach with a qualitative one in conducting semi-structured interviews (interviewing three people from each hierarchical level in each organisation studied) to find out how respondents had understood the questionnaire, and why they had answered as they did for particular individuals. (Cross & Parker, 2004a, p.8-9; 2004b, p.57) In this way Cross and Parker sought to ground the concept of energising.

This approach requires one set of people to evaluate another set (who are presumably not present at the time of the questionnaire being filled or the interview being conducted). They do this with a third set of people (the researchers) being witnesses either directly (during face-to-face interviews) or indirectly (via questionnaires). We might accordingly raise a number of challenges. Identifying someone as an energiser or de-energiser may be construed as speaking positively or negatively of them. Our willingness to pass such judgments depends on the person being judged (are they managers or subordinates, are they in the neighbouring cubicle or in an office in another country) and on how we perceive the role of the researchers (do we trust them to keep our responses confidential, how are we connected to them, how are they connected to the people we are evaluating, especially our managers). What we measure is someone's willingness to call another "energising". What we want to know, however, is whether the other *is* energising. For this reason we might prefer an approach that seeks to measure energising and de-energising more directly.

Psychologists measure mood and arousal by self-report - questionnaires in which a subject reports how they have been feeling over some time scale. Thayer's Activation-Deactivation Adjective Check List (Thayer, 1989, appendices I-IV) and Watson et al's PANAS scale (Watson et al, 1988) are typical of these. Subjects are asked to report how they feel for some time period and some list of adjectives. Time periods could include: "right now (that is, at the present moment"; "today"; "during the past few days", and extend to; "during the past year", and: "in general, that is, on the average" (Watson et al, 1988, p.1065). A twenty-item adjective list has, in random mix, positive adjectives - "enthusiastic", "interested", "determined", "excited",

“inspired”, “alert”, “active”, “strong”, “proud”, and “attentive”- and negative ones – “scared”, “afraid”, “upset”, “distressed”, “jittery”, “nervous”, “ashamed” “guilty”, “irritable” and “hostile” (Watson et al, 1988, p.1067). Watson et al report the two ten-item scales are “internally consistent and have excellent convergent and discriminant correlations with lengthier measures of the underlying mood factors”. (Watson et al, 1988, p.1069) Using short time periods in the instructions the scales fluctuate with mood. With longer periods (“during the past few days” and longer) the scales become stable like personality traits.

Self-reported measures can be compared with physiological evidence: heart rate, finger blood volume, skin conductance and muscle action potentials (Thayer, 1989, p.58). They can also be compared with each other (Watson et al, 1988, p.1069). Both Watson et al and Thayer find their measures vary over time (Watson et al, 1988, p.1069; Thayer, 1989, p.68-71). Energetic arousal is affected by illness (Thayer, 1989, p.95), food (p.96-7), sleep (p.97-8) and moderate exercise (p.88-93). Neither source discusses relating their measures to interactions with particular people, however.

Self-report questionnaires are also used to measure “subjective vitality” (Ryan & Frederick, 1997). This evidence then can be related to levels of intrinsic motivation – as indicated by the length of time a subject was willing to engage in some given activity (Deci, 1971; Deci & Flaste, 1996, p.25).

More recently, Dutton and Quinn have incorporated a self-report approach into a broader discourse analytic framework (Dutton & Quinn, 2005). They illustrate this with a conversation that was recorded and transcribed, including descriptions of body

language. The transcription could then be presented to the subjects to elicit from them recollections of changes in their energy levels during the conversation (Dutton & Quinn, 2005, table 3). In this way they may test various hypotheses about how energy levels are affected – via autonomy, competence and relatedness – by the speech acts identified in the text (Dutton & Quinn, 2005, table 2).

Collins notes that emotional energy may be measurable by the “style rather than the content of talk” (Collins, 1990, p.50-1). In a largely speculative discussion he suggests recordings of voice samples in particular interaction situations may be measured for “(a) loudness of tone; (b) speed of talking; (c) fluidity, hesitation pauses, and (d) false starts.” Turn-taking in conversations provide other indicators, such as the amount of time in delay between the end of one speaker’s turn and the start of another’s, and a speaker’s ability to occupy the attention space (“to get the floor”) versus incidence of contested speech turns. Studies of eye contact, facial expressions, body postures and movements may also yield indicators of EE.

“Since high EE is social confidence and dominance, it should be manifested in movements towards other people, especially movements that take the initiative and that lead to rhythmic coordination. Low EE, conversely, should show movements and postures of withdrawal, and low initiative.” (Collins, 1990, p.51)

This gives us plenty of plausible-sounding ideas about how to study emotional energy levels, without actually giving us concrete examples of these ideas having been tried out. Obviously the presence of a researcher-as-observer during an interaction has the

potential to disturb how the other participants behave. This may make validating a model of a particular situation difficult. Instead, we may have to employ emotional energy as part of an explanatory theory of phenomena on a different scale – such as occurs in Collins’s treatments of intellectual production (Collins, 1998) and violence (Collins, 2008).

2.8 Summary

In conclusion, we lack a unified concept of energy and face some choices if we are to extract a concept from the literature.

We have superficial agreement over “energy” having something to do with “feelings”. Beneath this surface, we have feelings of a positive nature being characterised as “feelings of energy”, “energetic arousal” or “subjective vitality”, with some suggestion of a link to social activity, especially interactions that affect one’s sense of autonomy, belongingness and competence. But various candidates are proposed for another, negative type of feelings, and both types of feelings are related to dispositions to act.

This brings in another concept of energy as the degree of motivation or disposition towards some action, whether accompanied by positive “feelings of energy” or not. For Collins “emotional energy” is a drive *towards* social interaction, takes different forms specific to the interaction situations, and is only experienced as feelings of enthusiasm when at a peak. For Ryan and Deci “subjective vitality” is a feeling of

satisfaction of needs and *comes from* social interactions, namely those that enhance autonomy, belongingness and competence.

We also found that Collins's "energy leaders" and "energy stars" - the high-energy instigators of the interaction rituals in which group members gain emotional energy - had the capacity to *de-energise* in the sense of leaving others feeling dominated and frustrated by a lack of opportunity to be the focus of attention themselves. High-energy, charismatic individuals were not necessarily "energisers" in Cross & Parker's sense.

When it came to measuring energy we again had a choice: between on the one hand something recorded by self-report questionnaires, and on the other a correlate and explanation of action.

We conclude, then, that though interesting in their respective fields (social network analysis, psychology, social psychology, sociology), work is required to clarify and unify these concepts of energy. In Chapter 5 we will argue a case for performing this work through simulation modelling - a task which we then attempt in Chapter 6. Before that, in Chapter 3 and Chapter 4, we survey the literature for previous attempts at modelling energy and its related concepts.

Chapter 3 How might we model energy?

3.1 Introduction

If there are intelligible and useful concepts of “energiser”, “energising” and “energy”, how might we model them? In this chapter we discuss the possibility of there being precedents for energy models that we might work with or learn from. In this section we draw upon the literature already cited to spell out what features we would desire in a model. Then we review other models that have included some of these features.

Cross & Parker (2004b, chapter 4) discuss energy as a property of individual people. Through interviews they identified it as a phenomenon of social interaction - both an experience remembered after particular events and an explanation for people’s disposition to repeat interactions with particular people. Cross and Parker’s questionnaires collected network data, each relation reflecting a general attitude on the part of one person towards another. For analysis they separated these data into two networks: energising and de-energising relations. Network metric calculations and maps were then based on these. So in their work we have energy related to people, social interactions and networks, and the motivation to repeat interactions with certain individuals.

In Ryan and Deci’s studies (2000) energy appears as one person’s intrinsic motivation to perform certain activities - primarily non-social ones. Social interaction events are still important in that they alter future rates of activity or dispositions to act, when

those events involve behaviour on the part of another person that affects the first person's sense of autonomy, relatedness and competence. Energy - in the form of intrinsic motivation - changes following interactions, and actions and practices are performed over time as expressions of levels of intrinsic motivation. So we have a dynamic concept related to time and non-social activities.

Randall Collins's theory of interaction rituals (2004) provides perhaps the largest list of relata for an energy concept. It is both an outcome and a determinant of social interactions. Energy charge on social coalitions determines which interaction partners are sought out again. Energy charge on cultural capital determines which cultural objects are focussed on, and which ritual practices engaged in. Similarity in this charged-up cultural capital determines the likely success of an interaction, and thus which groups reform over time. But by becoming symbols of group membership, the cultural objects and ritual practices are also effects of interactions. The network of socio-cultural opportunities determines future energy dynamics. However, social networks can emerge as patterns in chains of interaction rituals. Thus we find an energy concept - "emotional energy" - intertwined with cultural practices and objects, with groups, and with social networks.

Collins's theory would go some way to explaining the phenomena outlined in Chapter 1 of "communities of practice" (Brown & Duguid, 1991, 2000, 2001). Problem solving by individuals in the workplace is a social activity - the problems and solutions provide the cultural capital one needs for interaction rituals with colleagues in the canteen, while one's ability to solve problems on client site depends on the social relations one has built up with experts as well as interaction rituals of narration

about the problem structure. The community becomes the basis of learning - information in dry training manuals carries no emotional energy charge. But it also creates barriers to new ideas from outside the community - symbols of some other group, perhaps conflicting with those of the community's own. Work by social network analysts on brokerage and closure also noted this tendency for relatively closed groups to hinder the take up of innovations. A model based on Collins's concepts of "emotional energy" and "cultural capital" may elucidate the relationship between groups and innovation take up.

At present, however, there has been just one such model, created by Collins and Hanneman (1998) and published as a chapter in a hard-to-obtain book, with brief reference to it also in Hanneman & Patrick (1997). Hanneman's background is in system dynamics modelling. Collins (1988) devotes an appendix to the use of simulation models in sociology, and collaborates on a system dynamics model in Hanneman et al (1995). His model diagram for an interaction ritual in Collins (2004, p.147) also employs the stocks and flows of system dynamics.

That there is no other type of simulation model based on Collins's micro-sociology is a little surprising. In the second edition of Collins (1992) the final chapter is devoted to artificial intelligence, in which Collins argues that future AI creations will need to be capable of engaging in interaction rituals with humans, as this is how human agents acquire intelligence. Developments in AI since the late 1980s have largely been in agreement with this thesis (Luger, 2005). Earlier phases in the history of AI focussed on "heuristic search" in the 1950s and 1960s, and "expert systems" and the use of vast knowledge databases during the 1970s and 1980s. In the 1990s attention shifted

towards robotics and creations that were “embodied” and “situated” with capabilities emerging following interaction with humans (Brooks, 1991), and working in social groups in “multi-agent systems” (Jennings et al, 1998; Wooldridge, 2002). However, the intellectual justification for these moves has come from philosophers - for example Dennett (1991; 1998) and Clark, A (1997) - rather than sociologists.

Figure 1, illustrating the idea of *interaction ritual chains* and based on a figure in Collins (2004, p. 152, fig.4.3), could easily be read as the basis for an agent-based model (Gilbert & Troitzsch, 2005; Axelrod, 1997a) representing interacting agents with emotional energy and cultural capital as agent attributes. The attributes determine interactions and are updated as a result of interactions. The representation of interaction events at distinct points in time also suggests discrete-event simulation (Robinson, 2004). Agents are interdependent then both culturally and across time. Despite these hints of the possibilities, however, no agent-based or discrete-event simulation models have been published.

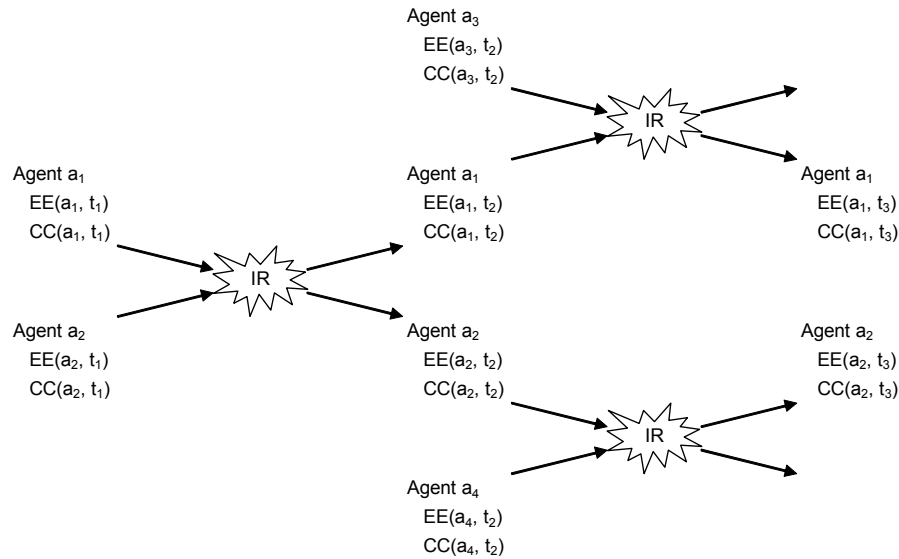

Figure 1 *The formation of interaction ritual chains*

The formation of interaction ritual chains - after Collins (2004, p. 152, fig. 4.3). Agents have emotional energy (EE) and cultural capital (CC) which determines the interaction rituals (IR) they perform. Following an IR event energy and cultural capital are altered, and the new stocks determine new IR events occurring at later times.

Two attempts are under way that may rectify this situation. One (Baker & Quinn, 2007) presents an agent-based model of agents with “energy and information”. We provide a critique of this working paper in Chapter 4, but for now we will note it does not model cultural capital or group membership. The other attempt is the work on which we report in this thesis.

Not being historians of sociology we can only guess at why there is no other simulation model based on Collins’s micro-sociology, but we suggest here two possible explanations for this absence. The first is that, despite a lineage including Durkheim’s work in sociology of religion and Goffman’s work on interaction rituals, Collins’s theoretical sociology (Collins, 1988; 1992) has not been close to the

mainstream. A recent survey of “Theories of Communication Networks” (Monge & Contractor, 2003) manages to miss out this tradition. Theories of social exchange and rational agency have provided the paradigm in micro-sociology for twenty years. By connecting with mathematical work in economics and game theory they provide the appearance of clarity and rigour, and perhaps also some more respectability for sociologists by association with these disciplines. A simulation model based on a rival paradigm of group solidarity and ritual might provide some of this same rigour if this paradigm should come into fashion.

Our second suggestion is that Collins’ theory, whilst relatively simple in the light of its extensive applications (Collins, 1998; 2004; 2008), may be too complicated for modellers to date. We would like to develop a theory of:

- energy and energisers,
- social interaction and networks,
- motivation and the take up of ideas, and
- culture and groups.

To represent all this in one model is no small order. We may need to simplify - to omit some of these, or omit some details of them and represent things in highly abstract terms.

At present, no simulation model covers all of this. However, these components may be found separately in other models. In the rest of this chapter we detail some examples for each component.

3.2 Network models

Cross and Parker's data on energising is network data. Could clues on how to model it lie in the flourishing world of social network analysis (SNA)? (Holland & Leinhardt, 1979; Wasserman & Faust, 1994; Scott, 2000; Carrington et al, 2005) Additions are needed to the graph theoretic constructs of the traditional SNA, including culture and dynamics.

Interest in social network dynamics - primarily changes to a network such as node and link addition and removal - has been aided by developments outside sociology, especially those made by physicists. Simple, abstract computer models have connected the statistical mechanics of graphs (Albert & Barabasi, 2001) to small world effects known from real social networks (Watts & Strogatz, 1998; Watts, 1999; Milgram, 1967; Granovetter, 1973), and scale-free degree distributions identified in various natural and artificial networks (Barabasi & Albert, 1999; Strogatz, 2001). Attempts are being made to inform various disciplines using these studies (Barabasi, 2002; Watts, 2003; Newman, 2003), not least social sciences (Watts, 2004; Kossinets & Watts, 2006).

These attempts at "sociophysics" (Stauffer, 2003) are not without their faults, however. For example, Barabasi & Albert's model (1999) that grows networks with scale-free architecture generated much excitement through its use of a "rich-get-richer" approach to adding links to nodes based on their current number of links. Analogies were drawn with the growth of the world-wide web and wealth distribution

(Barabasi, 2002). But Pujol et al (2005) point out this model lacks any basis in sociological theory, and so we should hesitate before drawing any conclusions about social phenomena. Various alternative algorithms have been identified for producing scale-free architecture, and they argue for one in which individual agents (represented by nodes) do not require knowledge of the degree distribution of the *entire* network - so-called "global knowledge". In their "Lo-Model", agents obtain knowledge of others' properties through direct interaction ("local knowledge") which they then store in agent memories of limited - or bounded - size. Choosing interaction partners via this "bounded rationality" they still manage to produce networks with interesting global architecture, including scale-free degree distributions for some interaction parameter values. Their interactions are given grounding in a micro-sociological theory by basing them on a prisoner's dilemma type game and social exchange theory. It would be interesting to test if rival theories of interaction (such as Collin's interaction rituals) can produce the same range of network architectures.

Along with dynamics, the other feature to be added to network studies is that of culture. Johnson-Cramer et al (2007) collected data on social networks - including energising relations - and on cultural values held by individuals in organisations. Their maps of the social networks use different node shapes to indicate different responses to questions on particular values and illustrate an association between clusters in the networks and common cultural values. Cultural values here would include attitudes towards participation, empowerment, teamwork, flexibility at work and innovation - the kinds of values a manager might want to encourage in their organisation, or might believe they have been encouraging. The success of attempts at cultural change could be assessed, and potential cultural divides identified. Adding

energising relations to the analysis suggested “people were energised in interactions that confirmed their views and were more likely to seek out those with similar views over time”. (Johnson-Cramer et al, 2007, p.102) But this interpretation must come supported by interview data as well. The networks are one-off samples - “snapshots” of the organisations. Ascribing causal relations between energising, interactions and culture cannot be done on the basis of just one snapshot.

This calls for a *dynamic* social network analysis, a subject that was identified as the cutting edge of network studies in (Breiger et al, 2003, especially Carley’s closing address). Monge and Contractor (2003) also call for it as part of their multi-theoretic, multi-level modelling approach (MTML; see also Contractor et al, 2006). They describe a simulation package, *Blanche*, intended to model network evolution involving mechanisms found in multiple (and rival) theories of communication networks (theories of collective action, homophily, contagion, and exchange, among others), and to model it using the attributes of nodes, links, cliques and whole networks of different modes. As noted already, Collins’s theory of interaction rituals does not feature in their book, so it is no surprise that *Blanche* does not represent a good starting point for modelling network evolution due to emotional energy. But if one already has network data from multiple time points (such as pre-merger, post-merger, or at six month intervals), then the SNA tools of p^* or Exponential Random Graph Models (ERGM) could be applicable (Robins et al, 2005). The powerful analysis package, *SIENA* (Huisman & van Duijn, 2003), allows one to fit binary data on edges and node attributes taken at multiple time points, using maximum-likelihood estimation via Markov Chain Monte Carlo simulation (Snijders, 2001; 2002). This offers a statistical route to models separating influence effects (where node attributes

change due to network links) from selection (where links change due to node attributes) (Steglich et al, 2004; Snijders et al, 2005). It is to be hoped that in the future authors in possession of data on energising relations - either from real organisations (for example, Baker et al, 2003; Cross & Parker, 2004b; Reinke, 2005) or the product of artificial ones in computer simulations (Baker & Quinn, 2007) - will try to analyse them using ERGM.

Where such network data are missing information on particular links, it may be useful to estimate the likelihoods of the link's presence and absence using other data, including node attribute data, and the Bayesian approach described by Rhodes & Keefe (2007). Their paper also proposes using the approach to dynamically model networks "as it is feasible to calculate how a network will reconfigure following an intervention". We are sceptical that Bayesian techniques that work well enough on "protein-protein interactions in genomic data" will extend to social networks. An intervention in a social network - for example, the removal of an energiser from an organisation, perhaps in an unprecedented or dramatic manner - is an event that generates discussion and reaction - even among those not directly linked to the removed person - and thereby alters the cultural resources of the network as a whole in complex ways. The applicability to social network data of this approach therefore needs investigating in future work.

In conclusion, then, there have been in recent years studies introducing culture and dynamics to network analysis and models. In the case of abstract models of network evolution, we have highlighted the absence of a sociological grounding that could include concepts of energy. In the case of empirical studies, the powerful dynamic

statistical tools now available have yet to be applied to energy networks. Thus we proceed with no quantitative analysis of the relations between energy, culture and networks of social interactions.

3.3 Models of contagion and social learning

Where there has been more interest in connecting network models to empirical data is in the study of contagion, including disease modelling (May & Anderson, 1988; May & Lloyd, 2001), marketing models (Bass, 1969; 1980) and the diffusion of innovations (Rogers, 2003; Young, 2003). In each of these models human agents are changing state (from “without” to “with”) as a result of social interactions, and empirical data typically concern the number of people or proportion of the population in a particular state after the passage of a particular time period - that is, the data are quantitative and concern aggregates.

Mathematical models can describe aggregate spreading phenomena when the component agents are homogeneous in their disposition to adopt or be infected, but the imposition of a “physical” network structure to constrain who interacts with whom, and the assumption of heterogeneous susceptibility among the agents (Young, 2006) both make analytical approaches difficult, if not intractable. Under these circumstances, simulation models seem the only alternative - indeed, disease modelling has been approached using system dynamics, discrete-event simulation and agent-based modelling (Bagni et al, 2002; Bigley Dunham, 2005).

Typically these models balance three causes of the state change: transmission from one node to another (contagion, imitation etc.); transmission from outside the system (immigration of infected person, advertising campaigns for innovations; media information for ideas), and; experience of the state change itself (which may be positive or negative in the case of innovations and ideas, or result in a further state change such as death or recovery in the case of disease). The famous Bass model (1969) includes transmission from outside as well as inside the system. Deffuant et al (2005) model agents trading off social value and individual benefit from an innovation. Vermeulen (2008) demonstrates in a model circumstances in which ideas persist in a population, despite being detrimental to the survival of their adopters.

What generates much of the interest in diffusion models are the situations in which spreading from one person to another is not straightforward. Empirical data on innovation adoption reveal lags - extended periods during which the innovation fails to take off as fast as the simplest models would predict (for example, the corn data in Rogers, 2003, p.271, fig. 7.1). One explanation for this phenomenon is to divide the population into categories - innovators, early adopters, early majority... through to laggards at the end (Rogers, 2003, chapter 7) - though to have explanatory power these labels must refer to properties of the agents before they adopt (personality in the face of novelty, ability to benefit, or location in a communications network) rather than describing the simple fact of how soon they actually did adopt.

Other models combine heterogeneity in agent qualities with a more complex contagion process. In Young's models of social learning (Young, 2005), agents adopt not once they hear about the innovation from someone else (as would be represented

by adoption at the first contact with a single adopter), but only when prior adopters have produced sufficient evidence of the innovation's advantage to cross an agent's personal threshold for adoption. Centola and Macy (2007) present a model in which agents adopt only if a given number of their neighbours have adopted as well - such as might happen if the innovation is perceived as particularly radical or risky. In a "small world" network - such as in (Watts & Strogatz, 1998) - where a few "long ties" connect members of distant clusters, such an innovation will be unlikely to travel across these "weak ties", since the nodes at each end are unlikely to share common neighbours.

Repenning's (2002) system dynamics model of innovation implementation combines the influence of managerial pressure from outside the system with awareness through word of mouth of the performance of an innovation relative to expectations. Managerial pressure is applied, causing commitment to the innovation to rise. When pressure is then removed, further dynamics of commitment depend on whether a "motivation threshold" has been crossed - the point at which word-of-mouth support deriving from the performance to date becomes positive. A feed-forward loop then drives commitment up further. Turn off pressure before this point, however, and the awareness of lack of progress causes instead a fall in commitment in a feedback loop. Thus the model suggests an explanation for the failure of innovations despite their efficacy.

(a) Initial population: 1 dove, 99 hawks

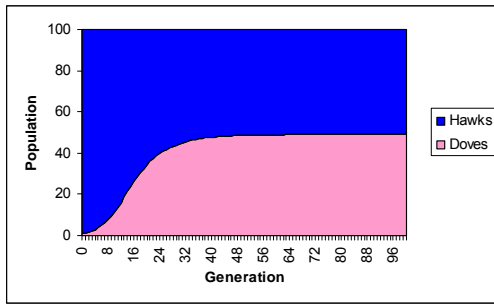

(b) Initial population: 99 doves, 1 hawk

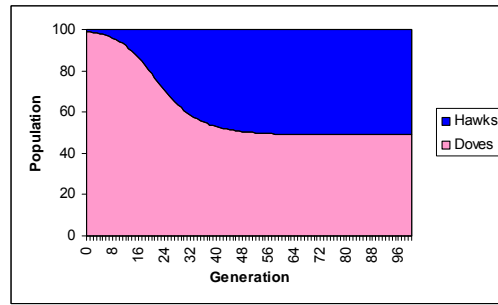

(i) Evolving populations of hawks and doves

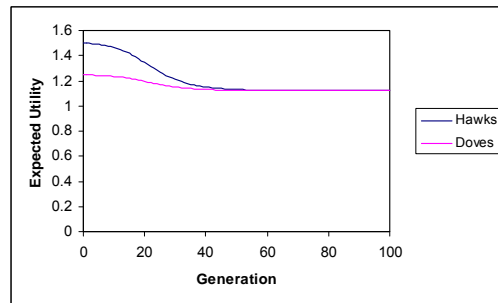
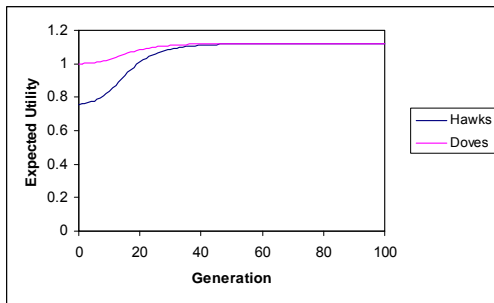

(ii) Expected utilities of being a hawk and a dove

Figure 2 A population of “hawks” and “doves” reaches an evolutionarily stable strategy (ESS)

Reproduction of Maynard Smith’s (1982) game of hawks and doves, in this scenario with payoffs: 0.75 when hawk meets hawk (HH); 1.5 when hawk meets dove (HD); 1 (DH); 1.25 (DD). The fitness, or expected utility, of being a dove or a hawk depends on the current proportions of hawks and doves in the population. Population proportions are then adjusted in line with the relative expected utilities. (a i) Starting from an initial population of 1 dove and 99 hawks, this system converges on an ESS with approximately 50% doves. (a ii) At this point the value in expected utility of being a dove is equal to that of being a hawk, so the population proportions become stable. (b) A population of 99 doves and 1 hawk converges on the same ESS, but from the opposite direction.

In some situations, increasing numbers of adopters can reduce the value of an innovation. Fashions and fads may be a case in point, as increasing adoption makes a practice less appealing to a trend-setter who pioneered it. In ecological systems the fitness of a particular species can vary with the relative balance between the various populations. John Maynard Smith’s (1982) analysis of game theoretic models of

“Hawks” and “Doves” demonstrates that an evolving population of competing individuals can converge on an evolutionarily stable strategy (ESS) at which the expected utility of being a “hawk” is exactly matched by that of being a “dove” (*Figure 2*). Analogous convergence occurs in systems based on learning and on cultural inheritance.

Although originally not diffusion models, Brian Arthur’s (1994) El Farol Bar model and the Minority Game of Challet, Marsili & Zhang (Challet & Zhang, 1997; Challet et al, 2004) inspired by it are complex adaptive systems models that can easily be extended with an imitation process between their agents. In both models, agents and their strategies are penalised whenever too large a group of them act the same way. Faced with common historical data to apply their strategies to, agents with adopting the same strategy will act the same way, thus undermining the value of that strategy until it becomes victim of its own success. In such systems, no one strategy can expect to dominate, or even survive in the population for very long. Diffusion can also work in favour of an innovation, producing increasing returns to scale as more people adopt and eventually locking the market into a state where that innovation dominates - as Arthur (1996) argues happened in the 1980s PC industry.

In the concept of heterogeneous agents we have a similar idea to that of modelling energisers and de-energisers with different transmission properties to the rest of the population. We have also noted models in which adoption can be made to depend on multiple neighbours in a network. In the language of social capital (Burt, 2005) innovations will struggle to make it in or out of a relatively closed group of adopters via a broker. Social factors can prove more important than experience or news of the

practical costs and benefits of the innovation, and external pressure from management or advertising campaigns. Such balances between forces intrinsic to a social network and those extrinsic to it, may be reflected in an energy model if the energy charge on cultural capital depends on both social factors (autonomy and belongingness, for instance) and more practical factors - such as an agent's competence with the ritual practices and cultural objects, or its material cost.

3.4 Models of Groups and Culture

None of the diffusion models discussed in the previous section included cultural groups. Our discussion of communities of practice (see section 1.3) suggested the cultural boundaries between these were particularly inhibiting to the diffusion of innovation. The only non-network attributes of the agents so far - the susceptibilities of the heterogeneous agents - did not vary beyond the trivial case of an adopter being unable to adopt more without first losing the innovation. In this section we describe models in which groups of agents emerge during a simulation run, and also models in which agents' susceptibility to influence by others depends on cultural traits acquired during the run. A key concept is that of *homophily* (McPherson et al, 2001).

3.4.1 Homophily & Small Worlds

Watts et al (2002) produce networks with emergent clusters in their investigation of the *small-world effect*, the combination in network structure of short path lengths with high clustering. Their earlier model (Watts & Strogatz, 1998) took as its starting point

a network with regular architecture (for example, a ring lattice) and rewired a small number of links to random nodes to produce the small world properties of relatively high clustering but relatively low degrees of separation. The later model creates a new network. Agents have attributes, each attribute representing a horizontal position in a vertical hierarchy of groups, the hierarchy running from groups of agents and up through various groups of groups. Each hierarchy defines for any pair of agents a “distance” between them, determined by how many levels up the hierarchy one must go to find the first common parent-group. The network of interactions is then formed by linking agents stochastically with preference for similarity. In this case this preference for similarity - or *homophily* - is calculated as the average proximity in terms of the hierarchies. The resulting networks have the small world property, and a searching algorithm based on selecting the neighbour with the most similarity / proximity to some target agent can produce chains similar to those observed in real small-worlds experiments (Milgram, 1967; Kilworth & Bernard, 1978; Bernard et al, 1988).

In the model, however, distances in one dimension or hierarchy are independent of those in another. If the hierarchies represent such social categories as profession, spatial neighbourhood, family or interests, we might question this assumption - for example, some spatial communities are based around particular industrial plants, requiring a number of people with similar profession, interests and skills.

How these social categories are formed is not modelled. Cultural groups such as communities of practice depend upon the acquisition of practices through social interactions (Brown & Duguid, 1991; 2000). The fruits of efficient search and

communication have yet to be added to the model of Watts et al, but they would affect this process of acquisition. We could reinterpret the groups of agents in the small-worlds model as representing shared practices rather than shared categories - communities and categories would then only emerge as interaction network clusters. But in this case, we would lose the connection with the empirical data from the real small-world experiments which were based on categories.

With regards to modelling Collins's emotional energy, if energy-seeking is to be more than just a synonym for homophily we must include group formation and the ritual practices which can carry energy charge. This represents a level of detail not present in a small-worlds model based on social categories.

3.4.2 Homophily & Imitation

Both group formation and a level of greater cultural detail are represented in some models of imitation, however. Axelrod's Cultural Model (1997a, chapter 7; 1997b) produces emergent cultural groups using two processes: homophily and imitation. Carley (1991) based a model on the thesis that "interaction leads to shared knowledge and that relative shared knowledge leads to interaction", in which agents move from an initial position of cultural diversity towards homogeneity. But Axelrod demonstrated in a variation on this model that cultural boundaries can also emerge. Imitation causes one agent to become more like another, but may thereby make it less like a third, and hence less likely to interact and imitate that third agent in the future. Exploration of the parameter space for Axelrod's model reveal settings in which systems converge on a state with multiple cultural groups, or "regions" - each

homogeneous in its members' culture but now completely unlike its neighbours, and so unable to alter further through agent interaction. The link between social interaction, culture and groups makes the Axelrod model highly appealing - in addition to its simplicity and extendibility - and we will discuss it further in later chapters (especially sections 6.2, 6.3 and 8.2, and Appendix A).

One drawback to the Axelrod model is that its systems converge on a static state. Cultural regions form, but do not break up. Mark (1998) extends Carley's (1991) cultural model by giving agents a process of forgetting. To Axelrod's model a continuous process of mutation - called variously "cultural drift" (Axelrod, 1997a, chapter 7; 1997b; Centola et al, 2006) and "noise" (Klemm et al, 2003a; 2005) - can be added to reintroduce variation. But depending on its rate this process has non-trivial implications for the number of regions (Klemm et al, 2003a; 2005). It also lacks grounding in sociological theory at this stage, with it unclear what a realistic rate would be or which processes determine a rate.

3.4.3 Polarisation and Alliance Formation

Some models include negative counterparts to principles of homophily and influence. Schelling's (1978) pioneering model of segregation showed how ethnically pure regions of agents can emerge when agents are given a little intolerance of the different. Lim et al (2007) use an agent-based model to explain patterns formed in real regions of ethnic conflict in the Balkans and India.

In Axelrod's model of alliance formation (1997a, chapter 4) forces of attraction and repulsion between nation states - based on real assessments of ethnic, religious, military and demographic factors, and on principles including homophily and hatred of previous opponents - led to the nation agents choosing sides in a way that closely resembled a real historical division. A scenario from a business case study enjoyed similar success (Axelrod, 1997a, chapter 5). The input factors however are fixed at the start, as is the number of sides - two.

In the network model by Macy et al (2003) ties between agents have either positive or negative valence. Negative valence implies agents employ xenophobia and differentiation instead of homophily and imitation. The paper reports systems invariably converge on states in which agents' relations put them in one of two groups, polarised towards those of the other group. Equilibrium states can be found with higher numbers of groups, but not obtained through simulation of network evolution.

3.4.4 Altruism, Tags and Ethnic Conflict

Why do agents - humans or non-human - cooperate? Despite the advantages of division of labour and economies of scale, animals with a disposition for altruistic behaviour can be taken advantage of by free-riders - agents sufficiently similar to the first to elicit help, but not offering costly help in return. In the biological case, the most selfish of genes will get the most benefit for the least cost, and hence be best placed to survive (Dawkins, 1976). Yet examples exist of apparent relations of self-sacrifice among - and between - humans and animals.

Answers to the riddle have included kin selection, reciprocity and punishment (Riolo et al, 2001; Hammond & Axelrod, 2006a). The theory of kin selection illustrates that “selfish genes” are not necessarily genes for selfishness in individual agents. Sacrifices for one’s genetic relatives may favour one’s genes - but only that proportion of ones’ genes that one shares with the relative. The game theoretic analysis by Price and Maynard Smith demonstrates that under some conditions individuals engaging in reciprocal altruism can survive alongside more selfish individuals as an evolutionarily stable strategy (Maynard Smith, 1982), even when the population starts out with one cooperator to many defectors (recall *Figure 2* earlier) - or for that matter, when the population starts with one defector amidst a group of cooperators, but these conditions, based on the fitness values in a payoffs table, are not universal. Nowak & May (1992) produced spatial versions: models in which agents arranged on a 2D grid choose between cooperative and defecting strategies for playing games against their neighbours. Depending on the relative merits of defecting over cooperation, some eye-catching - and chaotic - patterns can emerge on the grid while populations can converge on relatively stable, non-trivial proportions of cooperators and defectors. Reciprocity as the tit-for-tat principle has been shown in game theorists’ “Prisoner’s Dilemma” competitions to be a powerful strategy, but it is not unbeatable (Axelrod, 1997a, chapters 1, 2). Reciprocity is also difficult to maintain over longer periods of time, seemingly requiring the ability on the part of individuals to remember debts, or who owes a favour to whom. Agents capable of recognising transgression of a collective norm can punish free-riders, but if punishment costs the punisher, individual agents may prefer other options. A second-order norm (Axelrod, 1997a) - one that requires agents to punish known transgressors

of first-order, basic norms - merely pushes the free-rider problem up a level. Combining group norms, social sanctions and networks of relationships (Flache & Macy, 1996; Macy et al, 1997) produces complex systems with outcomes problematic for understanding altruism and collective action.

For this puzzle Riolo, Cohen & Axelrod (2001) propose a system based on a combination of tag-recognition and homophily. They simulate agents with “tags” - based some identifiable trait such as skin colour or accent. Each agent also has two dispositions to either aid others at some personal cost or punish them (“cooperate” or “defect”) - one disposition for interactions with agents of like tag, and one for interactions with agents with unlike tag. Simulating populations on a grid evolving over many generations, they identify many scenarios for which “ethnocentrism” - the disposition to cooperate with the similar and defect from the dissimilar - emerge as the most popular and majority strategy (Riolo et al, 2001; Sigmund & Nowak, 2001). A key element of this model is the presence of competitors for space (the resource) on the simulated landscape. Free-riders who do not support their support base - those of similar tag - will suffer indirectly as ethnocentric agents of rival tag out-perform them. (Hammond & Axelrod, 2006a; 2006b) This does not remove all free-riders from a population, but it does keep their numbers in check and preserve the ethnocentric strategy, making it evolutionarily stable.

The tag-based model offers a very promising route to explaining how there might emerge by natural selection human agents with a hard-wired preference for symbols of group solidarity and a tendency to display righteous anger towards those not respecting the symbols - in short an evolutionary explanation for the mechanisms

required by Durkheim's sociology of religion and Collins's theory of interaction rituals (Collins, 1981; 1990; 1993; 2004). The simulation models in (Riolo et al, 2001) and (Hammond & Axelrod, 2006a; 2006b) do not represent energy dynamics, however. We need to shift from using "land" as the resource to using agents' cultural capital stocks, and shift timescale from population generations to that of interaction rituals, with perhaps no movement in physical space, and no birth and death of agents. In the sociological theories agents show respect for symbols as sacred objects - or "sacred values" - producing a form of homophily. Interestingly, Axelrod crops up again in studies of "sacred values" in (Atran et al, 2007; Atran & Axelrod, 2008).

We have then found plenty of interest among modellers in the relations between networks of interaction, cultural attributes and group formation. A preference for cultural similarity caused groups to emerge and constrained who could interact with whom. Interactions, however, were how culture spread. The Axelrod Cultural Model demonstrates this formation of distinct cultural boundaries that inhibit continued transference of ideas. Combining these cultural differences with an emotional energy charge would help explain the strength of ethnic conflicts in the world, or why agents are so motivated by different traits, practices and objects as to treat them as sacred or sacrilegious. We have a plausible explanation of why ethnocentrism persists in evolution. We lack, however, a model for more frequent interactions.

3.5 Models of Work Performance

In the previous section we gave examples of models in which groups and norms emerged from processes involving social interactions. But not all influences on agents need be social. In this section we list some ways in which non-social context has been provided, relative to which a value or performance of the modelled system can be defined.

If interactions can have costs and benefits that are non-social, the trade off between these and social influences becomes worthy of study - not least because the costs and benefits may be of greater interest than the emergence of groups. As we noted in section Chapter 1, part of the motivation for organisation studies in management science is the idea of relating organisational structure or design to some kind of performance measure. In some of the models referred to in section 3.4 a non-social context was included - an interpretation of the culture as knowledge, or a fight for survival for an evolutionary strategy. In contagion models (section 3.3) there is an assumption that the spreading phenomenon has some value extrinsic to the system - negative in the case of disease spread, positive usually in the case of learning - which then motivates a response to the phenomenon in real systems. The network models in section 3.2 are of interest in part because of resemblance to the search for solutions in real social networks (Watts & Strogatz, 1998; Watts et al, 2002; Granovetter, 1973), and the robustness of real-world networks under failure or removal of their parts (Barabasi, 2002).

One approach to defining performance is to define some kind of environment in respect of which agents' attributes have a value or fitness. For example, in March's model of organisation learning (1991) "knowledge" is defined by the matching of

agents' attribute values to an independently determined (and potentially changing) environment. Improvements in this agents-environment correspondence represent learning. For a more sophisticated environment some studies employ Kauffman's NK fitness landscapes (Kauffman, 1993, chapter 2; Kauffman, 2000, chapter 8). Originally intended as a model of evolution in theoretical biology these have been reinterpreted as modelling intra-organisational design (Levinthal, 1997; Levinthal & Warglien, 1999), inter-organisational strategy, team make-up (Solow et al, 2002) and the search for technological improvements (Kauffman et al, 2000). The appeal of this framework lies in it representing interdependent components (organisations, decision makers, technologies), with simple parameters for controlling the level of interdependency which has been found to "tune" the "ruggedness" of the landscape - in effect, determine how easy the landscape is to search. To date, however, the "decisions" or "attributes" in these models have been limited to binary values ("Yes/No"; "Present/Absent"), making them hard to integrate with some of the cultural models in section 3.4.

Another approach to modelling performance is to set one's agents a task or tasks. Schmidt (2000) demonstrates the capabilities of the PECS framework with the ADAM model - a search by one agent for food sources, and the Learning Group Model - model of social knowledge acquisition. Carley (1996; Carley & Lin, 1997) uses a classification task - the "Radar task" - to demonstrate the interplay between cognitive capabilities and organisational structure. Anderson (1993) describes how more sophisticated agent designs allow for the solving of tasks requiring decomposition into subtasks.

More complicated models include more than just agents and tasks. The pioneering “Garbage Can Model” of organisational decision making (Cohen et al, 1972) includes decision makers, problems, solutions and decision-making opportunities. In the agent-based version by Fioretti & Lomi (2008) all four are types of agent that must coincide if a problem is to be solved. Curiously, it also includes concepts called “energy”. Participants’ “expended energy” represents their ability as decision makers. Problems’ “required energy” represents their degree of difficulty. Comparisons of the two quantities determine the outcome of a decision making opportunity. Fioretti & Lomi’s revision of the original model, however, appeared too late to influence our own search for energy models, and it involves no groups, cultural capital or social interaction to link it with our energy theories from Chapter 2.

Social networks, on the other hand, do appear in Carley’s work on organisations’ qualities. She models organisations as multi-modal networks linking people, resources, tasks, and knowledge. Organisational performance is defined in network terms - including the lengths of paths linking resources to tasks (Carley & Kamneva, 2004; Carley & Remminga, 2004). The robustness of an organisation can be assessed by Monte Carlo simulations that reiteratively remove nodes and links and record the impact on the performance metrics (Carley et al, 2003).

Models involving this many components require much work to understand their behaviour under different parameter settings (though Hazy & Tivnan (2003) have extended one). To then add the elements of energy theories may require too much. Likewise, the other definitions of performance employed in these agent-based models may distract us from the main task of understanding energy and energisers. So until a

particular benchmark representation of work performance emerges in the literature - for which it would help if researchers placed more computer models and empirical datasets in the public domain - we may have to make do with a simple representation of our own.

3.6 Models of Human Agents

Simulation models of human agents vary in their detail and sophistication from the financial traders with “zero intelligence” in (Farmer et al, 2005) to models that are intended to form the steps towards designs of “autonomous agents” - robot agents able to perform unanticipated tasks when out of range of human control (D’Inverno & Luck, 1996). We cannot survey all the fields involving “agents”, but a number of modelling frameworks refer to concepts of interest, including social interaction, “emotions” and “motivation”.

3.6.1 BDI: Rational decision making and action

Various agent architectures have been developed with a focus on how the one agent can solve problems without input from other agents. The BDI framework (Rao & Georgeff, 1995) represents agents with beliefs, desires and intentions, but the contents of these intentional states do not appear to include other agents’ intentional states. In Panzarasa et al (1999) they do, and this paper adds to the framework roles, and social relationships such as imitation. But whereas Rao & Georgeff list examples of practical applications of the framework, Panzarasa et al, in common with most of the literature

on “Multi-Agent Simulation” (MAS) (Wooldridge & Jennings, 1995; Jennings et al, 1998; Wooldridge, 2002; Panait & Luke, 2005) present only the definitions for a framework, not evidence of actual models coded and run. Without the latter, we cannot validate the modelling framework for its representation of social relations. The criteria for accepting contributions to this literature do not include ability to explain or elucidate social phenomena - in sharp contrast to the agent-based models discussed earlier in this chapter. The bibliographies for MAS include no sociologists. Though Panzarasa & Jennings (2001) offer hope of this situation improving, their idea of “contemporary organisation theory” does not seem to extend far beyond the rather un-contemporary Carnegie School (see Chapter 1).

For the most part in extensions of the BDI framework, the only outside influences are philosophers of action (in particular, Bratman, 1987; Mele, 2005). We note, however, within philosophy there are authors for whom intentional states, rationality and expectations of utility are things we ascribe to others on the basis of their actions in order to predict their future actions (Dennett, 1987; Davidson, 1984; Ramsey, 1990). How good one’s ascriptions are in a particular case depends on how reliable one’s prediction is. It does not depend on there being something in the other person’s head that might be called a belief or an encoding of a belief. That is, *how* human beings produce the appearance to others of BDI states need not involve explicitly encoding BDI states. If practitioners of MAS use BDI to control a robot’s behaviour, what matters for the interpreter is how well he or she predicts that robot’s behaviour - not whether he or she ascribes states identical to the ones actually encoded in the robot’s memory. (A smarter application of BDI may be the AGILE architecture (Taylor et al, 2004), which employs BDI as part of a user interface to simulation agents whose

actual cognitions are determined by the SOAR architecture (see next sub-section.) So, we are left suspecting that most use of BDI framework is philosophically questionable, and BDI models may not be the best route to producing the appearance of BDI, to say nothing of the appearance of agents with sociological energy.

3.6.2 Reinforcement Learning, adaptive agents and SOAR

Reinforcement Learning (Sutton & Barto, 1998) is another concept lying behind a large body of multi-agent and agent-based simulations. Agents learn through iteratively interacting with and adapting to their environments which provide them with feedback in the form of “reward”. This has been supplemented with a concept of concepts of inter-agent interaction (D’Inverno & Luck, 1996), autonomous “motivation” (Luck & D’Inverno, 1998) and “intrinsic motivation” (Stout et al, 2005). This latter concept is not identifiable with Ryan & Deci’s “intrinsic motivation” and lacks references to a sense of belongingness and competence. But it enables agents to distinguish between internal and external motivations, where motivation is part of a process of generating goals when goals are not specified by a model programmer or a human controller.

Adaptive learning processes appear in various types of simulation model. Macy & Flache (2002) have employed the reinforcement learning mechanism of Bush & Mosteller (1951) to enable agents to adapt while interacting through games such as Prisoner’s Dilemma. Arifovic (1994) implemented adaptive learning with a genetic algorithm in a “cobweb model” of firms trading in a market. Brian Arthur’s (1994) agents update a toolkit of prediction methods in the light of recent common

experience. Reinforcement Learning also inspires the SOAR cognitive architecture used in Carley's work on cognition and organisational design (Carley, 1996; Carley & Lin, 1997). The SOAR ("State Operator And Result") agent architecture (Lehman et al, 2006) models cognitive states for the purpose of goal-directed behaviour. Recent development integrates this cognition with emotion (Marinier et al, 2008; Jones et al, 2002). This integration has had applications - in military simulations - but has yet to be related to the sociological phenomena of culture and groups. In a mostly admiring review of SOAR (Dennett, 1998, chapter 19), the philosopher and evolutionary theorist Dennett wonders if SOAR is not in fact *too* good at cognition. Human cognition is sometimes tiring, painful or exhilarating, and may involve drifting focus of attention, time wasting and mistakes. Cognitive architectures such as SOAR fail to reproduce such phenomena, though at present Dennett cannot rule out the possibility that some of these are emergent behaviour of some future, more developed version of SOAR. Still, their absence reduces the value of SOAR for providing insights into philosophy of mind and the evolution of consciousness (which are Dennett's concerns, e.g. in Dennett, 1991; 1997), and for providing insights into the social phenomena that emerge when humans with imperfect cognitive and emotional properties interact - which, of course, are our concerns. Sophisticated cognitive architectures may not be the best way of representing agents in social simulations, which typically model interacting agents in much simpler terms.

3.6.3 The PECS framework: Emotion and social status

Representing human agents realistically in social situations *is* a concern for the PECS framework of Schmidt (2000), which has influenced the PAX simulator of military

humanitarian relief operations and addresses similar issues to the emotion extensions of SOAR. With PECS agents are represented as having “Physical conditions”, “Emotional state”, “Cognitive Capabilities”, and “Social Status”. This framework may be viewed variously as powerful - incorporating lots of aspects of agents - or as complicated - since full use of it involves many processes, each requiring assumptions and choices of parameters and distributions. Omitting some of the framework will simplify things, of course. Brailsford & Schmidt’s (2003) attempt to use PECS to add personality traits to a DES patient model “did not use the full PECS agent structure, in that our ‘patient’ entities had no sensor or perception components”. But although they report that adding PECS to a DES model was relatively easy, “further empirical work is required, firstly to derive and validate more realistic forms of the model equations, secondly to select the appropriate psychological variables, and thirdly and inevitably to collect data” - no small amount of work!

If we accept the relative complexity of the framework, can we find within it the resources needed to model energy and energising from social interactions? The PECS framework does include a concept named “Energy”. This refers to a fairly general agent resource, typically obtained from food, and comparable to energy in physiological terms. Lack of energy causes a drive - “hunger”. This is the main “Physical condition” of the agent. Emotional states can include “fear” and “anger”, and have an “intensity”, or degree. Both these and hunger are motivation concepts - they raise the chance of particular action responses - but they have no explicit link to social groups.

For a link to sociality we have to look at the concepts of “Social Status”. “Social satisfaction” is obtained up to a given maximum through membership of groups in response to an agent’s social need. The process of being satisfied is influenced by an agent’s “social make-up”.

“Social make-up means an agent’s capacity to make contacts, to make friends, to experience joy on social occasions etc. This feature will determine how quickly an agent feels lonely and abandoned when he does not belong to a group and how quickly he is able to experience social satisfaction in a group.”

(Schmidt, 2000, p.72)

From Cross & Parker’s work (2003b) one’s “energising characteristics” (see Chapter 2) will affect one’s capacity to make contacts - to find willing interaction partners, and thereby experience more joy. But Schmidt’s description of “social make-up” seems to stress being able to get something *out of* an interaction, rather than being able to put something *in* - and the grammar of “energiser” suggests the latter is what should be stressed in a concept of “energising”.

In the Learning Group Model (Schmidt, 2000, chapter 8) - intended to illustrate the concepts of “social status” - agents have no memories associated with particular groups or their members. Presumably these could be added under the framework as “Cognitive capabilities”, but we would then need an association between these and Social Status. In addition, it is not clear how the cultural capital of Collins’s theory would be modelled under PECS, given the close links in the theory with groups and

emotional energy. The concepts of “autonomy”, “relatedness” / belongingness and “competence” (Ryan & Deci, 2000; Quinn, 2007) are also absent.

So we are left feeling that PECS is not currently suitable as a framework for models of energy or energisers, though further development of the relations between its P, E, C and S components may alter this, and more widespread use of it may illustrate better its capabilities. In particular, it may yet prove to be a valuable basis for agent-based models of social phenomena if employed. But its present lack of connection with sociology or organisational studies, together with the relatively low number of papers reporting on its use by other researchers, means it does not tempt us away from the task of models based on energy theories.

3.7 Summary

Our quest for modelling techniques that might do justice to the concepts of Cross & Parker, Ryan & Deci and Collins has covered models of network evolution, contagion and social learning, groups and culture, work performance, and agent problem solvers of various designs.

Models by physicists linked abstract properties of evolving networks to real sociological phenomena such as the “small-world effect”, though currently lacking grounding in micro-sociological theory. Statistical analysis tools offered the chance to understand networks, cultural values and their dynamics, but had yet to be applied to those in possession of data on energising relations. Interest in contagion and learning in social networks had proposed several factors involved in the spread, and failure to

spread, of ideas. This led us on to one factor in particular, homophily, or preference for interactions with the culturally similar. When combined with imitation in Axelrod's Cultural Model, this can generate cultural groups whose boundaries inhibit continued transmission of ideas between these groups - a phenomenon recognised in the communities of practice discussed in Chapter 1. A model of the evolution of cooperation - based on tags - offered an explanation for why humans have this preference for the similar, though we noted this model did not cover the same phenomena as a cultural model. Studies linking models to inter-ethnic conflict however demonstrate how important processes of cultural homophily are. Relating energy, groups and culture to some notion of work performance would also be important, but introduces extra factors, as would attempts to represent agents with cognition and specific goals and tasks. Some modelling frameworks have been proposed that represent agents with cognition, emotion and sociality, but none of them derive from the sociological theory incorporating social interaction, emotional energy, cultural capital and group solidarity.

Thus we conclude that there exists a gap for a simulation model based on notions of energy, especially Collins's, to fill - one that might explain the relation between groups and cultural spread. In Chapter 6 we will describe a family of such simulation models. Before that, there is the matter of a potential rival - an attempt at a simulation model of "agents with energy and information" by Baker and Quinn (2007).

Chapter 4 The Baker-Quinn Model: a Critique

4.1 Introduction

Baker and Quinn (2007) have produced the only other agent-based model of energy we know of. It attempts to build on both Collins's theory (especially 1981; 1993; 2004) and the empirical work described by Cross & Parker (e.g. 2004b, chapter 4), and describes the construction and use of an agent-based simulation model, following the guidelines produced by Davis et al (2007). As such, it represents the closest comparison to our own work, and if we had found it a satisfactory solution to our needs, it would obviously have had an impact on the contents of this thesis. It is only a working paper submitted for publication and not a finished, post-peer-reviewed publication, so some of our comments may not apply to any later versions. However, some of our critique raises fundamental problems with the paper and the models described, and may not be rectified so quickly. When, in the last chapter, we review our own set of models, we will find plenty of weaknesses and need for further research in our own models. But we will argue they cover more of the theory around energy than does the most developed *Baker-Quinn Model* (hereafter "BQ Model").

4.2 Positives

Their models are intended to address a research question: "What happens to information use in organisations over time and how do networks evolve if people

trade off emotional energy and information?” (Baker & Quinn, 2007, p.40) Each model introduces new features and at each stage its typical range of behaviour is described. In the light of this behaviour Baker and Quinn form nine propositions about network evolution in organisations, which represent a development of the theory of energy by being suitable for new empirical research and integration with other theoretical work.

For the most part the paper is clear and easy to follow. The paper lists agent attributes, equations, parameters, the initialisation of the population, simulated interactions and updating of attributes, and the results of testing each type of model. As such, it goes a long way towards enabling us to reconstruct their models and replicate their results – a valuable form of model verification (Axtell et al, 1996; Axelrod, 2006).

There are plenty of references to literature supporting the model features and assumptions behind the models, especially to Collins (1981; 1993; 2004), Ryan & Deci (2000), Baker’s work with Cross and Parker (Cross et al, 2003a; Baker et al, 2003), and various authors on social psychology and on social networks. Such references give the impression that the features of the model are well-grounded and the model is valid, though they do not entail that the authors referenced would endorse this use of their work, nor that they would endorse some of the features being supported by other people’s work. We cannot follow up every reference here, but we will note the variation in authors mentioned. Whereas some agent-based models can be reduced to one or two principles or concepts - such as with the Axelrod Cultural Model (1997a, chapter 7; 1997b), the construction of the BQ Model has a large number of choices about processes and parameters to be justified, and some

scepticism may be warranted about the coherence of the theoretical work backing it up.

4.3 Questions about the model design

As Baker and Quinn put it - following the contention of Davis et al (2007, p. 480) - “simulation research is usually based on at least some clearly unrealistic assumptions”, and they suggest as examples “those factors or forces that are assumed to be constant or random” (Baker & Quinn, 2007, p.42). To the list they then give we might add:

“that the social processes underlying the evolution and performance of organizational networks are goal-directed, and that agents engage in purposive behaviour in pursuit of organisational goals (e.g., seeking information to get work done and fulfil one’s work responsibilities)” (Baker & Quinn, 2007, p.4)

These agents are well-behaved - they do their duty as laid down by the organisation - and by a happy chance their organisation has a coherent set of goals they can follow with no conflict of interests, and no internal strife. We must also assume that the agents’ success in obtaining information is equivalent to the organisation’s performance - that is, that for the organisation more information is always a good thing. A more plausible representation of a real organisation might model individual agents’ goals as distinct from official organisational goals, and include the possibility of quantity of information becoming a problem - though of course, this would make for a more complicated computer simulation.

$$E_i(t) = E_i(t-1) + \left[Z_{ji}(t-1) + Z_{ij}(t-1) + (2 \times E_j(t-1) - 1) \right] / 3$$

(a) Equation 1: the calculation of agent i's energy level

$$Z_{ij}(t) = Z_{ij}(t-1) + E_j(t) - E_j(t-1)$$

(b) Equation 2: the calculation of agent i's "relational energy"

Figure 3 Equations 1 and 2 from the Baker-Quinn Model

Equation 1 calculates agent i's energy level following an interaction with agent j. Equation 2 calculates agent i's relational energy, or attribution of energy to agent j. This becomes agent j's expectations for energy from agent i.

Other assumptions worth thinking about include the four occasions the authors adopt something "for simplicity". In addition there are occasions when we would have liked to see evidence of sensitivity analysis. For example, in interactions agents choose a partner from a sample set of just three participants. This simplifies the computation needed for simulating interactions. Although the computer must store an N*N matrix of relations, it does not have to process much of that data each iteration. (Though the storage might prove a limitation if we wanted to model very large populations.) But it would be interesting to know more about the relation between this sample set size and the behaviour of the model.

The authors do claim sensitivity analysis was conducted on the weightings of variables used in equation 1 (p.19, see also *Figure 3(a)*), the calculation of energy levels, but no details are given beyond the assurance that they "explored various weights in our simulations but none changed the long-run effects of the simulation in noticeable ways" (p.20). This would benefit from more detail being given on what constituted "noticeable ways" here.

We find mysterious the promise: “[M]athematical proofs of Equations 1 and 2 are available from the authors upon request.” (p.22) It is not clear to this author what axioms these two equations can be being “proven” from.

Also needing more justification is the decision to truncate energy levels and relational energy levels in cases when they go outside their respective ranges of $[0,1]$ and $[-1,1]$ (*Figure 4(b)*). These fixes are made necessary by the otherwise uncontrolled positive feedback loops implied by equations 1 and 2. The model would benefit from a theoretically grounded method for preventing exponential growth and shrinkage.

A further questionable aspect of the design of the model is that an agent initiating an interaction cannot be de-energised in the interaction. Any partner expected to be a de-energiser is rejected without cost to either agent. The workings of the model make very rare the dyads in which only one relation is de-energising. But this means in effect no agent’s energy level drops below 0.5. At the end of a simulation run nobody is feeling down!

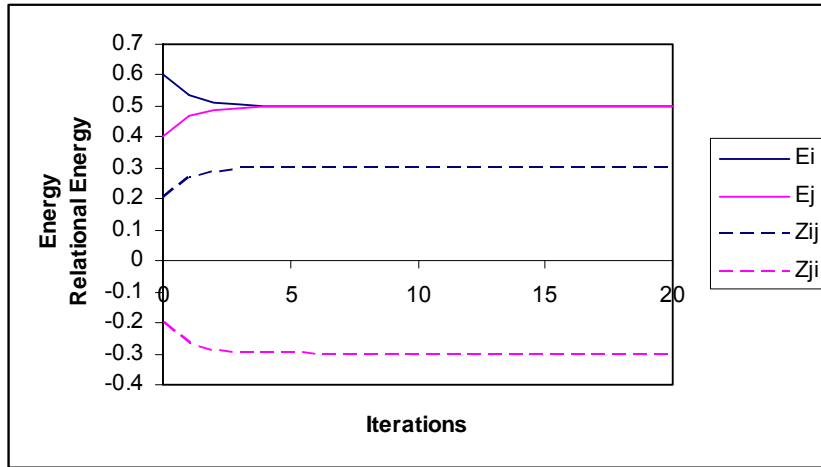

With initial settings: $E_i=0.6$, $E_j=0.4$, $Z_{ij}=0.2$ and $Z_{ji}=-0.2$

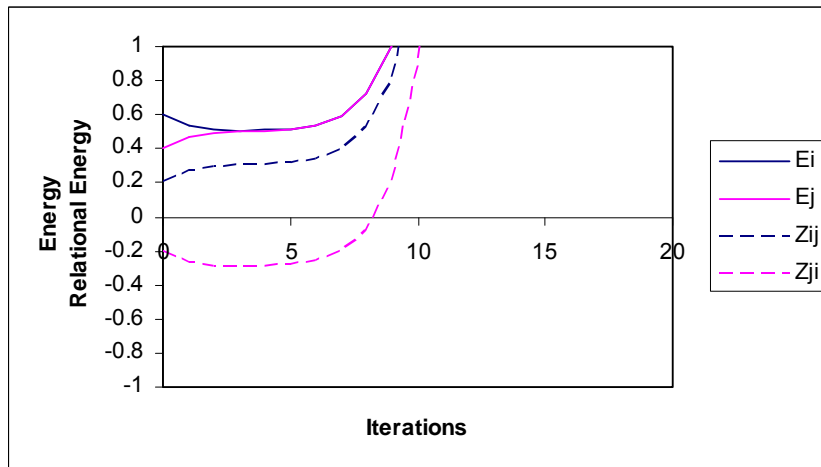

With initial settings: $E_i=0.601$, $E_j=0.4$, $Z_{ij}=0.2$ and $Z_{ji}=-0.2$

Figure 4 Energy levels and Relational Energy in the basic version of the Baker-Quinn Model

Energy levels (solid lines) and Relational Energy (dashed lines) in the basic version of the Baker-Quinn Model for a population of just two agents, i and j , over 20 interactions. In (a) we here start the system off with $E_i=0.6$, $E_j=0.4$, $Z_{ij}=0.2$ and $Z_{ji}=-0.2$. For equilibrium E_i and E_j must be equally distant from the midpoint for energy, 0.5. In addition, Z_{ij} and Z_{ji} must be equally distant from their midpoint, 0. Otherwise energy and relational energy change exponentially, as in (b). Given the starting point in (a) we can see energy levels converge on the midpoint, 0.5. Relational energy adjusts accordingly. So Z_{ij} , i 's attribution to j , and j 's expectations of i , rises by the amount of energy i has lost and j has gained.

4.4 Is it a model of energy?

We may ask to what extent the “energy” and “relational energy” constructs are grounded in the literature on energy surveyed in Chapter 2.

Baker and Quinn “do not simulate capability, autonomy, or inclusion explicitly” (p.18) - by which they mean Ryan & Deci’s (2000) concepts of competence, autonomy and relatedness/ belonging - but claim “these mechanisms are implicit in our model of how people interact with each other”. It may be asked, however, to what extent this is a model of agents with Ryan and Deci’s concepts. Ryan and Deci conducted research into intrinsic and extrinsic motivation to perform certain activities, but agents in the BQ Model only engage in social activity for the purpose of gaining information. There are no other activities represented.

We may also question how close the relation is to Collins’s concept of emotional energy. There is no “cultural capital”, no symbols of “group membership”, no material resources and no ritual - all important aspects of Interaction Ritual theory (Collins, 1981; 1990; 1993; 2004), as is stratification based on power and group status.

Finally, Cross and Parker describe people as having energising and de-energising “characteristics”. These are behavioural habits which may be altered by self-awareness and coaching. It is hard to see how this can be reconciled with the constructs in the BQ Model.

4.5 Is it a model of information?

To address their research questions the other construct Baker and Quinn need to represent in their models is information use. We noted in Chapter 1 the interest in using computer simulations to answer questions on organisational performance, and Baker and Quinn's choice of title and research question would attract people to their paper for this reason. But this means the way in which information is represented is particularly important, and as with energy, we feel disappointed at the result.

Baker and Quinn admit (p.42) several aspects of information have been missed out. Individuals have no information stocks represented, so - unlike energy - information gain in interactions has no effect on them. Future sample sets of potential interaction partners will be sampled with uniform chance, with no regard to how much information they might have. An individual's own pre-existing stock of knowledge might have determined the meaning and value of a new item received, but by omitting stocks this does at least avoid what would be an additional level of complexity.

There is also no non-work-related information - i.e. no information that does not contribute to the organisation's "performance". The model also omits "external constraints on the organisation", or any external or internal source of meaning for the "information" being gained.

Baker and Quinn claim seeking and obtaining higher energy leads to more use of information. "[S]eeking payoffs in emotional energy can actually promote information use... even though people are so motivated to seek energy in interactions

that they trade off information and emotional energy” (Baker & Quinn, 2007, p.40) It is this trade off between two objectives - information and energy - that Baker and Quinn think makes their model particularly interesting. But this use of information is not modelled! What is represented in the model is that seeking higher energy (or at least avoiding de-energising) leads to higher energy. What that higher energy means for non-energy-related calculations is not represented. The model needs to supply a reason why it should be called a model of information seeking. Otherwise, a modeller might just as well claim that energy was used for playing football, and hence argue that the model demonstrated seeking payoffs in emotional energy can actually promote football.

Thus information has no use, no consequences, and there is no memory for information. No problems are being solved with information. Information providers are selected at random for an initiator to choose between.

In the model output listed in their table 1 “information” is based on which interaction partner of the sample set was chosen (1 if the first was chosen, 2/3 if the second, 1/3 if the third, and 0 if none). “Performance” is calculated by multiplying information scores by an initiator’s energy level at time of interaction. The “Performance” scores of more than 95% are indicating that most interactions succeed at the first partner, and most initiators have energy close to 1. This situation comes about because de-energising relations are few - based on the other statistics approximately 1 in 49 partners will yield expectations of de-energising, so they are rarely encountered. But such a relatively energising network is obtained through seeding the initial population’s network with energising relations, through not allowing the initiator to

choose de-energising interactions, and through designing a convergent network evolution. The high performance score looks like the result of the choice of initial conditions and model design - not some deep feature of information processing in social systems.

4.6 An attempt at model replication

Confidence in Baker & Quinn's work might be enhanced if we could replicate experimental results in a program developed from their paper. As Axelrod (2006) acknowledges, replication is rarely easy. Experienced agent-based modellers attempting to replicate well-publicised work can struggle. In our own experience the level of clarity in Baker & Quinn (2007) is good. Although it is not yet a published version, using its descriptions to construct our own program was easier than with papers by certain other modellers. But for replication of results the paper falls short at the end. Its "table 1" contains "the statistics for a representative simulated organisation from each version of our model" (Baker & Quinn, 2007, p.24). "Statistics" here are agent population statistics from single (well-chosen?) runs, not aggregate statistics from n runs of the simulation which would be more reliable as indicators of the behaviour of a model (Robinson, 2004, chapter 9). Comparing them to the output from 500 replications of our own version of the BQ Model in its "Hierarchy" version (*Figure 5*), and following their suggestion to exclude any runs that resulted in a system converging on a largely de-energised population (30 out of the 500, in this case), we find not one of our runs produced an energising network with average degree ("ENetMean") as low as theirs, and the figures for graph centralisation look like they have come from another type of metric calculation. Their

example has too many “Null Dyads” and too few “Mutual Dyads” by our lights. Including the cases that converged on de-energising did not improve the mismatch in dyad counts. Tests of the next simplest model, their “Positive Initial Expectations” model, also revealed similar problems. Clearly, to understand whether we are running the same models we need them to provide statistics from multiple simulation runs, but that their results fall beyond our most extreme cases suggests some difference in processes.

		Mean	LB	UB	Min	Q1	Median	Q3	Max	BQ
EMean	1	0.825	0.824	0.827	0.779	0.814	0.825	0.837	0.870	
EMax	2	1.000	1.000	1.000	1.000	1.000	1.000	1.000	1.000	
EMin	3	0.500	0.500	0.500	0.500	0.500	0.500	0.500	0.500	
NumHighEnergy	4	42.47	42.28	42.66	35.00	41.00	42.00	44.00	48.00	
NumLowEnergy	5	0.00	0.00	0.00	0.00	0.00	0.00	0.00	0.00	
ZMean	6	0.154	0.154	0.155	0.141	0.153	0.155	0.157	0.162	
ZMax	7	1.000	1.000	1.000	1.000	1.000	1.000	1.000	1.000	
ZMin	8	-0.790	-0.807	-0.773	-1.000	-1.000	-0.794	-0.633	-0.346	
NumEnergising	9	548.2	546.7	549.6	497.0	538.3	549.0	558.0	589.0	
NumDeenergising	10	58.5	57.2	59.8	31.0	48.0	57.0	67.0	115.0	
Info	11	99.2%	99.1%	99.2%	96.4%	99.0%	99.3%	99.5%	99.9%	99.4%
Performance	12	96.7%	96.6%	96.7%	93.9%	96.5%	96.8%	97.1%	97.5%	95.5%
ENetMean	13	10.96	10.93	10.99	9.94	10.77	10.98	11.16	11.78	7.70
ENetMax	14	48.90	48.86	48.93	45.00	49.00	49.00	49.00	49.00	
ENetMin	15	3.40	3.33	3.46	1.00	3.00	3.00	4.00	5.00	
ENetStdev	16	12.42	12.39	12.44	11.04	12.33	12.47	12.58	12.91	
ENetGraphCentralisation	17	79.0%	78.9%	79.1%	72.4%	78.6%	79.1%	79.5%	81.3%	44.3%
ENetDensity	18	22.4%	22.3%	22.4%	20.3%	22.0%	22.4%	22.8%	24.0%	
DNetMean	19	1.17	1.14	1.20	0.62	0.96	1.14	1.34	2.30	1.00
DNetMax	20	4.41	4.29	4.54	2.00	3.25	4.00	5.00	11.00	
DNetMin	21	0.00	0.00	0.00	0.00	0.00	0.00	0.00	0.00	
DNetStdev	22	1.09	1.07	1.11	0.69	0.95	1.06	1.20	2.17	
DNetGraphCentralisation	23	6.7%	6.5%	7.0%	2.1%	5.0%	6.2%	7.8%	18.9%	4.2%
DNetDensity	24	2.4%	2.3%	2.4%	1.3%	2.0%	2.3%	2.7%	4.7%	
NullDyad	25	892.02	891.19	892.85	870	886	892	898	917	974
AsymDyad	26	57.45	56.78	58.11	36	52	57	62	80	65
NegAsymDyad	27	1.88	1.75	2.01	0	1	2	3	6	2
MutualDyad	28	245.34	244.63	246.04	217	240	246	251	263	161
NegMutualDyad	29	28.28	27.63	28.93	14	23	27	32	56	23
MixedMutualDyad	30	0.03	0.02	0.05	0	0	0	0	1	0

Figure 5 Aggregate statistics of 500 replications of our reconstruction of the Baker-Quinn

Hierarchy Model

We include results on Energy (“E”), Relational Energy (“Z”), “information”, “performance”, the networks of energising relations (“ENet”) and de-energising ones (“ZNet”) and dyad counts. Statistics shown include the mean, the lower and upper bounds of its 95% confidence interval, minimum, maximum, median and 1st and 3rd quartiles. Baker & Quinn’s output from a “representative simulated organisation” is given for comparison in the final column (“BQ”).

4.7 How good is the empirical validation?

Lack of multiple simulation replications also undermines any attempt to evaluate Baker and Quinn's results in the light of their empirical data on real organisations. Focussing on the three most developed simulation models, several results in table 1 lie outside the range of values observed in the five real energising and de-energising networks: in particular, "Normalised Indegree" and "Graph centralisation" in the Energising Network, and "Null", "Asymmetric", "Negative Mutual" and "Mixed Mutual" in the dyads counts.

Dyad census, which here does not fit very well, is not the most demanding of tests. Counting triads and higher-order network features or motifs is becoming increasingly common in the analysis of empirical network data (Carrington et al, 2005, chapter 10; Milo et al, 2002; 2004). *Triad census* was described in a standard social network analysis textbook in 1994 (Wassermann & Faust) and there are free tools for calculating them and other *motifs* (for examples, *Siena* (Snijders, n.d.) and *mfinder* (Alon, n.d.)).

Fitting data on node degrees (numbers of links per node) and network degree centralisation is relatively trivial when one can control a parameter like those used to initialise the model (see *Figure 6* for examples). As well as assumptions and choices of function, there are four parameters for populating the initial energy and relational energy values. Another four are used to control the decay rates for energy and relational energy. For comparing output, on the other hand, we have degree and centralisation figures for two types of network, and six dyad types - ten data points if

we treat them as independent of each other (which they are not – for example, there are a constant total number of dyads). With so many parameters and so few outputs, we are entitled to ask how surprising it is that the model achieves the output it does.

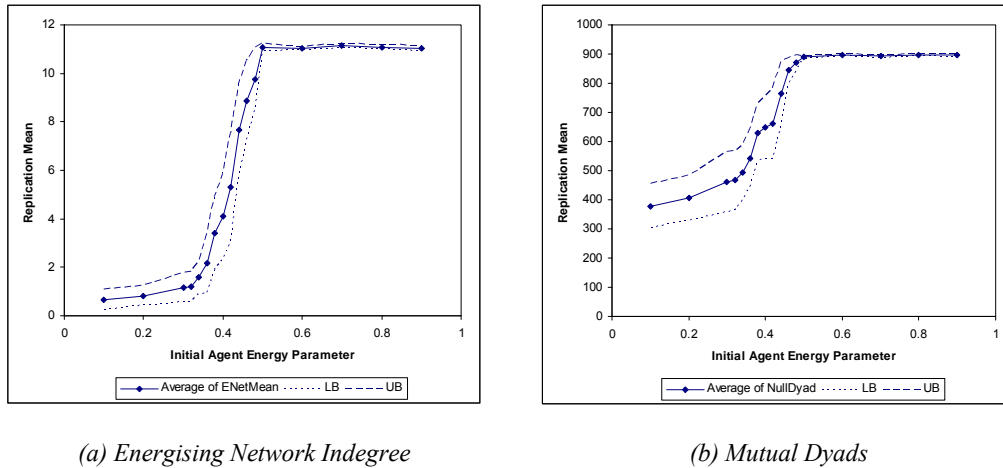

Figure 6 Illustrative aggregate statistics of the Baker-Quinn Hierarchy Model

Illustrative aggregate statistics of 20 replications of our reconstruction of the Baker-Quinn Hierarchy Model for a range of different values of the energy initialisation parameter (the mean of a normal distribution). Baker and Quinn’s results were obtained by setting it to 0.5. 95% confidence intervals for the replication means are shown as well. Clearly a wide range of values can be obtained by changing the input parameter. Notice that the mean of “Mutual Dyads” plateaus well below 974, the value cited by Baker & Quinn in their table 1!

Further problems arise when we examine the details of a typical run of the Hierarchy version of the BQ Model. The idea behind this model is that there are now two types of agent, with their type determining the probability of interaction partners being of a particular type. Five of the 50 agents are intended to represent “Managers”. *Figure 7* shows the matrix of relational energy after a typical run, with energising and de-energising relations shaded. The system has converged to a state where nearly all relations involving one of the five managers (agents 1 to 5) - either as ego or as alter

or both - are energising. (On the fewer occasions a run converges on a system with mostly de-energising relations, the picture is the same, but with de-energising relations for the managers in place of these energising ones. A key driver in determining which state the system converges on seems to be whether the Managers had predominantly high or low energy at initialisation.) That is, in these model organisations the managers are all wonderful energisers (except for those few organisations where they are the most dismal of de-energisers!) But Cross and Parker (2004b, e.g. p.50) cite cases of real organisations they studied where most of the de-energisers were the managers. Clearly the energised state in *Figure 7* is not a good representation of one of these.

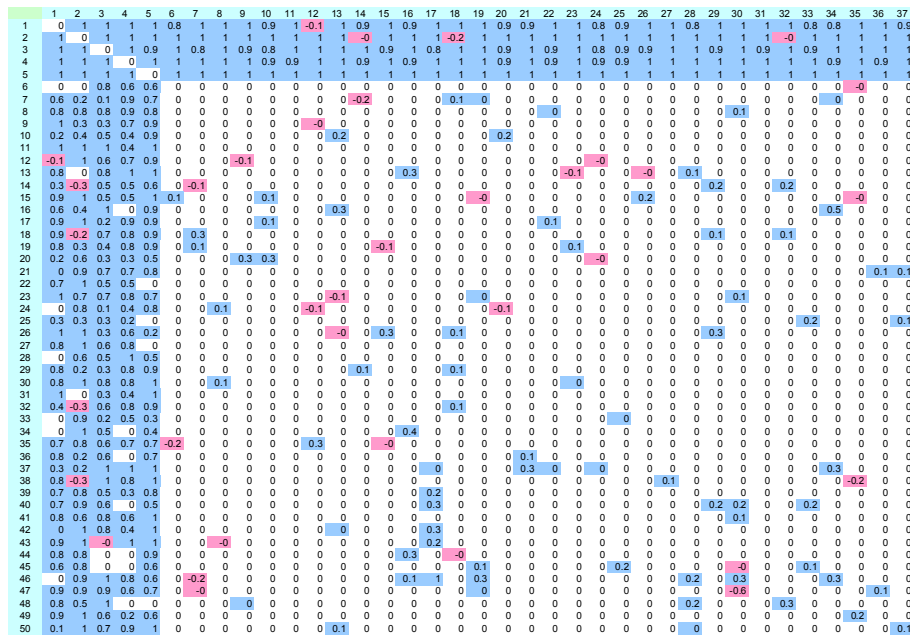

Figure 7 The matrix of relational energy values

The matrix of relational energy values (“ Z_{ij} ”) at the end of a typical run of Baker and Quinn’s Hierarchy model. Cells shaded blue represent energising relations; pink ones represent de-energising ones. As can clearly be seen, the five agents belonging to the top level of the hierarchy (agents 1 to 5) are almost entirely energising and energised.

But a de-energised state will produce the wrong statistics to resemble those of the empirical networks in table 1. So we must ask whether the real organisations studied for table 1 had these miracle managers, and a qualitative divide between worker types. If so, it would be worth mentioning this. If not, then there seems a risk of readers inferring erroneously a degree of empirical validation from the resemblance between the “representative” Hierarchy model statistics and those of the empirical organisations.

The fact that the BQ Model can be relied on to produce a small set of de-energised final states given sufficient simulation runs suggests we should be asking whether there is not an empirical analogue. Baker and Quinn mention this minority of cases - they seem to have run 20 replications for each test of each model (Baker & Quinn, 2007, p.28, 33, 35, 37) – but do not propose any real-world interpretation of it.

Baker and Quinn do not claim the model outputs in table 1 are statistically reliable, or that the empirical data have validated any versions of the model. But there is a risk that the positioning of single-run simulation outputs next to empirical data will create an impression of more empirical validation than is actually there. The paper would benefit from highlighting the fact that the outputs are from single runs and have been specially selected by the authors from at least 20 replications, some of which (the de-energising states) would have looked completely different.

4.8 Conclusions about the Baker-Quinn Model

In its present form the working paper Baker & Quinn (2007) has left us unconvinced that this is a model of energy and energising. Neither does it seem like a model of seeking and obtaining useful information, nor have much to indicate it is a model of an organisation. It would benefit from more work to justify it theoretically and empirically, and our attempt to reproduce it failed. A published version of their paper may, of course, improve on the current situation.

But that we have been able to identify faults is testament to the clarity and structure of the paper, for which it deserves credit. It also aided attempts at replication of the model and experimental findings by its provision of many details on model design, equations, initialisation and actual output, though our own attempts questions about differences in behaviour. Finally, we are, of course, happy to endorse Baker and Quinn's contention that an agent-based model of energy and information in an organisation is something worth developing. For now, however, we shall seek our own path towards a model of agents with energy.

Chapter 5 Justifying the use of agent-based simulation modelling

5.1 The Research Objectives

In section 1.3 we identified literature on how a particular type of cultural group – communities of practice - affect motivation and the take up of ideas. We also noted that the cultural boundaries between these groups could hinder the dissemination of innovations, with potential implications for the performance of organisations dependent on these groups. Social network analysts Cross and Parker (2004b) have identified roles in motivation for “energisers” and “de-energisers” (section 1.4), and have developed a method to identify individuals playing these roles. But in Chapter 2 we found a lack of unity in the psychological and sociological literature on “energy-like” concepts. The literature *was* able, however, to relate energy concepts to social interactions, cultural capital, group membership, intrinsic motivation and a person’s sense of autonomy, belongingness and competence. As noted in Chapter 1, simulation models have been used in the past to develop organisational theory, but in Chapter 3 we failed to identify any models of energy in the required sense, and found dissatisfaction with the most explicit attempt at one (Chapter 4). We therefore conclude there is a gap to be filled, and we state our objectives as:

- To develop the theory of energy and energisers - in particular:

- To understand better the relation between energy, culture, group formation and social interaction
- To investigate how energisers influence the take up of ideas, the formation of groups and the performance of work

5.2 Introduction to our methodology

To serve our objectives we will produce agent-based simulation models of agents with energy and culture engaging in social interactions. These models will represent energisers, take up, groups, and work performance, and they will test in experiments whether and under what conditions energisers beat non-energisers and de-energisers. We describe the models and experiments in the chapters that follow.

In this chapter we explain why we think simulation modelling can address these objectives and make a contribution to knowledge in this area. Our key point is that simulation models - though often thought of as tools for prediction - can also be used to promote theoretical understanding (sections 5.3 - 5.5). We discuss which of their features help make research based on a simulation model credible (5.6). We next select one of the major forms of simulation modelling - *agent-based* simulation modelling - and explain why we think it preferable in this case (5.7).

5.3 Why use simulation modelling?

Writers reflecting on the use of simulation modelling in social studies have proposed a variety of purposes for it. Some mention prediction - for example, (Harrison et al, 2007) - but Chapter 3 did not include any simulation models that made forecasts of future events for a represented real-world system. If deterministic, computer simulations demonstrate what follows from a given set of abstract assumptions. If stochastic, they demonstrate what could follow and with what frequency distribution. To extrapolate to a real-world system from these findings about an abstract, artificial system is much more controversial. More common are attempts to develop theory (Davis et al, 2007; Quinn, 2000; Hanneman, 1995). Simulation models - especially agent-based simulation - can do this by:

- illuminating core dynamics, unobscured by surplus details (Epstein, 2008);
- allowing experimentation to generate novel theory (Davis et al, 2007), and exploring the full range of implications of theoretical statements (Hanneman, 1995);
- raising new questions (Epstein, 2008);
- suggesting analogies (Epstein, 2008);
- testing logical consistency (Quinn, 2000) or internal validity (Davis et al, 2007);
- guiding data collection - indicating what phenomena should be searched for and what data should be collected to seek them (Epstein, 2008);
- explaining, including explaining as-yet unpredictable phenomena (Epstein, 2008).

They are not intended to replace other social studies methods - such as ethnography, statistical analysis or discourse analysis. But they have capabilities the others lack. They enable us to conduct thought experiments on a scale and in complex scenarios far beyond those previously possible (Davis et al, 2007) - indeed experimentation is not a notable feature of mathematical and statistical modelling (Hanneman, 1995). Also unlike other methods, the agent-based models mentioned in Chapter 3 bridge the micro-macro-level divide by showing the *macro*-level patterns that emerge from *micro*-level interactions, and then allowing exploration of their sensitivity to structural changes on the micro level (Macy & Willer, 2002) through varying parameter values, decomposing theoretical constructs, varying assumptions and adding new features (Davis et al, 2007). In summary, simulation modelling joins both theory-creating methods (along with multiple case inductive studies) and theory-testing methods (such as statistics) - or occupies a “sweet spot” between these two (Davis et al, 2007).

We are happy to endorse these remarks on the use of simulation modelling. We will not be trying to fit our models directly to empirical data on energy - we work at one remove at least from empirical studies (see Table 1). But we propose to engage in theory development by attempting to bring together certain theoretical constructs from several different authors, for which some of the qualities listed here make simulation ideal.

Table 1 Empirical sources for our energy concepts

	Main researchers		
	Cross & Parker	Ryan & Deci	Randall Collins
Background	Social Network Analysis; Business consultancy	Social Psychology	Sociology
Venue	Work organisations	Laboratory, Classroom, Workplace	Wherever relevant for studying education, intellectual production, violence, property etc.
Phenomena	Social interactions	Activity performance before and after social interactions	Interaction ritual performances
Data collection	Questionnaires giving social network data; Interviews	Quantifying of activity performance - e.g. timing; Observation of language & gestures used - e.g. transcripts; Extrinsic motivations applied Y/N?	"Micro-situational" data: ethnography; photographs; video; first-hand accounts; frequency counts of ritual performances
Concept names	Energising & De-energising relations; Energisers & De-energisers	Intrinsic motivation; Subjective vitality; senses of autonomy, belongingness, & competence	Emotional energy; Group solidarity
Example outcomes affecting the phenomena	De-energisers identified and coached; Energisers selected for teams	Controlling language and tasks avoided - e.g. through training; Motivation tactics revised - e.g. compensation schemes	Predictions made re. patterns in future data; No interventions documented, but casts doubt on interventions implied by other theories - e.g. class-based explanations of violent crime
Key references	Cross & Parker (2004b)	Ryan & Deci (2000); Deci & Ryan (2002)	Collins (1979; 1981; 1998; 2004; 2008)

5.4 Two paradigms for simulation modelling

How do we make contributions to knowledge using simulation modelling? In this section we outline two approaches, representing different scientific paradigms (Pidd, 2004) and competing for our attention - though in practice they complement each other as the one concentrates on structuring problems while the other focuses on solving them. In one the simulation model is intended to be a representation of some aspect of a real-world system. In the other it is intended to form a representation of people's mental models, and where more than one person is involved in its creation, it may represent a fusion of different mental models - a group consensus among various subjective viewpoints. It is this second paradigm that best serves our research objectives, so we must spell out its details carefully.

The distinction here has an origin in the philosophy of "truth" (Kirkham 1998a; 1998b). A "true" model in the first approach is one that corresponds to reality, and accuracy is the mark of success. In the second approach coherence takes priority. The success of the modelling activity depends primarily on how well the distinct viewpoints sit together encoded in the model, including whether they are logically consistent. Success is affected by whether or not a simulation model has represented each participant's mental model accurately. But when business or decision-making success depends on coordinated efforts and group solidarity, participants may be willing to trade personal representation for consensus - or may even be willing to adjust their own viewpoints in the light of the others' views and the model's behaviour.

These two approaches should also be familiar from the history of Operational Research. They are represented by "hard" and "soft" OR techniques respectively

(Pidd, 2004), and sometimes characterised as “problem solving” and “problem structuring”. The motivation for the emergence of Soft OR is given in (Ackoff, 1979). Over-focus on textbook optimisation and forecasting exercises had taken academics away from OR’s world-war-two origins as the application of science to decision making of vital practical importance. Real-world situations in business and other organisations had a complexity and instability far exceeding that of textbook exercises. They were “messes”, not clear-cut problem scenarios, and they involved people as stakeholders, whose buy-in to any proposed solution was essential for its success. After a brief “Kuhnian crisis” and scientific “revolution” (Dando & Bennett, 1981), room was found for a new, “soft” paradigm alongside the old (Rosenhead & Mingers, 2001). As Mingers (1992) points out, the two paradigms reflect different philosophies of social science. Hard OR exemplifies *Positivism*, and aims at prediction and explanation of some objective reality. Soft OR exemplifies a *Interpretivist* or *hermeneutic* philosophy, and aims at facilitating communication and understanding among many people with their own subjective mentalities. Mingers, following a prediction by Dando & Bennett (1981), identifies a third approach - *Critical OR* - aimed at emancipation, but our focus here is on the first two. Reflections on the practice of simulation modelling in OR have concluded that it commonly sits somewhere between hard and soft (Robinson, 2001). It enjoys the rigour of hard OR through the precision of its computer modelling and the statistical analyses of its outputs, but through the discipline of “conceptual modelling” (Robinson, 2007a; 2007b) it serves as a “tool for thinking” (Pidd, 1996) among groups of stakeholders, promoting soft OR ends instead. This view of simulation modelling places it closer in use to system dynamics modelling (Sterman, 2000; Morecroft & Sterman, 1994; Morecroft, 2007).

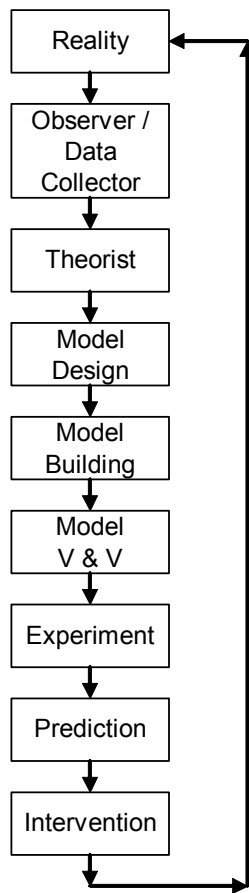

Steps:

1. Objective reality causes observation to be made, data to be collected.
2. Reflection on data in the light of past theory and observations leads to new theoretical understanding.
3. Theories drive the design of a conceptual model.
4. A computer model is constructed to this design.
5. The model is verified and validated.
6. Once satisfactory, experiments are conducted with the new model.
7. On the basis of the model behaviour predictions are made concerning the real world system.
8. An attempt is made to intervene in the real world on the basis of the experience with the model.
9. Objective reality is altered by the intervention.

Figure 8 Example of a linear, positivist approach to understanding simulation modelling

In order to emphasise the reality-modelling interaction loop we have removed any other cycles.

To illustrate the difference between these two paradigms consider some diagrams (Figure 8, Figure 9). Figure 8 shows a linear, positivist approach to understanding simulation modelling. In order to emphasise the reality-modelling interaction loop we

have removed any other cycles - in real examples of this approach we would expect some repetition of steps before a particular stage was passed. (Following poor experience at verification and validation, for instance, we could alter the model construction or rethink the design.)

In addition, some steps are undertaken with awareness of the potential requirements for future steps - the model may be designed to address a question concerning options for the future intervention. Finally, some interventions alter not the objects depicted in the model but our behaviour towards them - such as when a clockwork model of the solar system leads not to attempts to play with real planets, but can affect our decisions on where to point our telescopes on future occasions. But these points aside, the flow chart illustrates how simulation models are determined by the real-world system they are supposed to represent, and how they can be used to make predictions, answer what-if questions and guide actions concerning those same systems.

The mark of a good model here seems to be correspondence between model behaviour and reality. This correspondence is believed to be measured when we ask in the light of later observations:

- Did our model-inspired predictions come to pass?
- Did our attempted interventions result in the changes we expected?

We might wonder how easy this correspondence is to achieve when the reality in question involves people capable of reacting to the very processes of being observed and modelled. Attempts to capture their reactivity in the model can themselves be

reacted against, and an infinite regress threatens. In addition, human systems are complex and shifting - can the modelling project make a contribution before its depiction of reality becomes obsolete? These problems would suggest this approach is not suitable for social simulation.

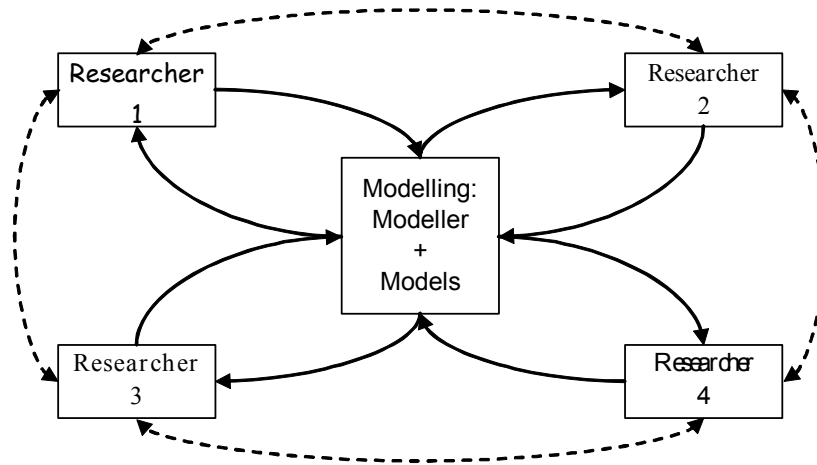

Figure 9 Example of an interpretivist approach to understanding simulation modelling

The modelling brings together researchers of different types and different views, and becomes the focus of interactions between them, though other avenues for dialogue may exist at the same time. Outcomes depend on the qualities of both the modeller(s) and the models.

Contrast this situation with that of *Figure 9*, an illustration of the interpretivist approach. Various researchers - who may be theorists or data analysts, qualitative or quantitative researchers, academics or industrial practitioners, and who may come from different disciplines - have different viewpoints. The modelling project is one of maybe several attempts at dialogue between these researchers. The modeller attempts interpretations of the researchers' output - their analysis and theories - by representing them in computer code. (Depending on the software package in use, this modelling may actually be something performed by researchers themselves.)

When the simulation models represent the mental models of multiple researchers, there may be tacit tensions between those viewpoints that are revealed during the design, construction and exploration of the simulation. In addition, there may be unforeseen implications of those viewpoints surprising to the researchers. In becoming simulation models, mental models are made explicit (Epstein, 2008). Researchers can react to the public event of the modelling and the shared experience of the computer models, and perhaps adapt their private mental models in the light of this experience. Group consensus is not guaranteed, but it may be facilitated by the modelling project, and decisions based on this group interaction may have more support by the participants.

The mark of a good model is whether it leads to greater understanding between the participants in the modelling process, even if this means they agree to differ. So rather than ask about correspondence to a common reality we ask:

- Can the participants make their views clear enough to be represented in code?
- Where do they agree? Where do they disagree?
- What follows logically and probabilistically from their views?
- Do the participants understand each other's perspective better as a result of the modelling?

Note, however, the mark of a good model is not how well it represents the mental models of *all* the researchers - they may be incoherent or incompatible with each other.

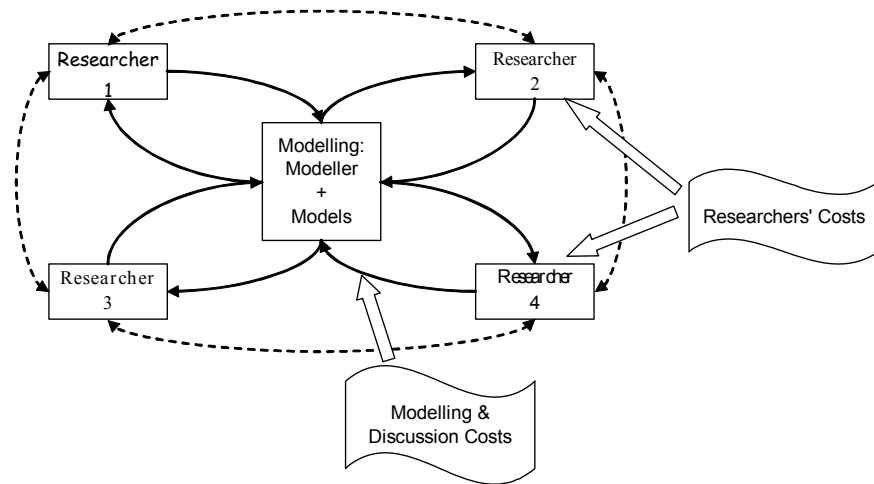

Figure 10 Recognition of the fact that the modelling process has costs determined by extrinsic factors

Success in communication is not guaranteed - for example, Researcher 4 may prove too hard to understand in the time and with the available resources.

This modelling process does not take place in a vacuum. Material reality plays its part - as suggested by the addition of costs in *Figure 10*. The researchers' activities carry costs, including the expression of their mental models, and some actions may be more expensive than others in physiological, physical, financial and social terms. Likewise, the other components of the modelling process involve costs. Hardware and software has to be paid for, as does computing time. Some simulation models are easier than others to create, verify, modify and interpret. Modelling outcomes are social constructions - but some things are easier to construct socially than others. Unlike the positivist account earlier, though, we make no claims about depicting within models the external reality. One can certainly reflect on the outcomes of a past or an on-going modelling project, and have an opinion concerning the costs and benefits. But accurate knowledge of costs is not a prerequisite to meeting them.

This concludes our presentation of the two modelling paradigms. Like the positivist approach, the interpretivist approach faces difficulties. People's mental models may be complex and shifting, and their expressions of them ambiguous and incoherent. Participants may not have the same level of interest in reaching consensus and supporting group decisions. But these are problems faced in all attempts at communication, not just in simulation projects, and *some* level of communication would seem to be possible - we find sufficient value in it to continue our attempts. So in this light we feel no hesitation in advocating the interpretivist paradigm use of simulation modelling for our research objectives. If, as a result of this hermeneutic process, clarity and consensus emerge as to what organisational problems with energising are being faced, then focus may switch to the approach of Hard OR and the solving of these problems.

5.5 Science as coalition formation

Once we understand which paradigm to employ with simulation modelling, a lot of criticisms of it from other types of researcher drop away. To those who ask "what if the model misses something out?" we retort that all models are simplifications - they *all* miss something out or represent something wrongly (Sterman, 2000, chapters 1, 21). The perfectly accurate representation of human agents with energy would be human agents with energy - but then the real system is not a model, and certainly not one we can experiment with as we please. We can always make our models more complicated, by adding extra factors and extra details to existing factors - but complication rarely enhances communication. The role of the simulation as a tool for

learning and thinking in groups (Morecroft & Sterman, 1994) is undermined by a pursuit of model complexity (Morecroft, 2007, p.412).

Some are suspicious of the simulation model as forming a “black box” - no one understands how it reached its output from its input. Lehtinen & Kuorikoski (2007) identify this as part of the explanation for top economics journals’ relative lack of papers on simulation modelling. They suggest the activity that passes for “understanding” in economics is derivation of theorems from assumptions - if one can perform the logical deductions oneself then one is recognised as having understood, and one feels this is so. Deduction is exactly the part the computer takes over in simulation modelling, so it is no surprise if academic economists find its use a problem.

But being a “black box” is not sufficient reason for avoiding them. Sociologist of science Latour (1987) argues black-box formation is actually part of science. We cannot question every assumption, experimental procedure, or scientist’s competence, and few of us are in a position to question any of them. Over time more and more of these have become unquestioned and disappeared from our attention. In this light the sheer reliability of the computer simulation - its slavish reproduction of the same output given the same program and input - and the ease with which its programs become modules for constructing new programs make it an excellent basis for creating such black boxes. The reliability of the black box allows us to focus on what surrounds it: the assumptions on which it is built; the data it is populated with or validated against; the interpretation of its output, and; the discussions of problems it is

intended to facilitate. From this perspective economists' love of the deduction would seem to be distracting them from more important business.

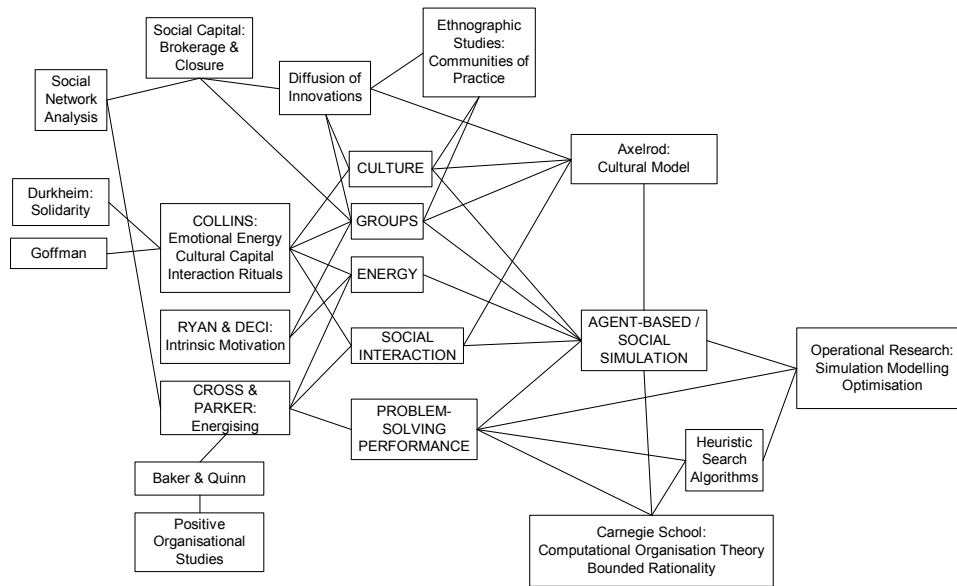

Figure 11 A coalition of concepts

Illustration of how a simulation model of agents with energy can attempt to bring together concepts of culture, groups, energy, social interaction and problem-solving performance. In this way, a coalition is being attempted that includes three sources of energy concepts - sociologist Collins, social psychologists Ryan and Deci, and social network analysts Cross and Parker - and simulation modeller Axelrod, as well as the literatures on social capital, diffusion of innovations, communities of practice, computational organisation theory, heuristic search and Operational Research.

Latour's actor-network theorist's view of science conceives of scientists' work as the formation of socio-technical coalitions - not just alliances of people, but also materials, machines, theories and ideas. *Figure 11* illustrates how this thesis represents an attempt to form a coalition. We have chosen three sources for a concept of energy (Chapter 2) - Collins, Ryan and Deci and Cross and Parker - and we will try to encode a concept that unifies all three. Collins, we have noted, connects us to

concepts of culture, groups and social interaction rituals. But a theory that unites these may explain some of the problems in the diffusion of innovations, as identified in the literature on both social capital and communities of practice (see section 1.3). Axelrod's cultural model is a social simulation that already links culture, groups and diffusion, but does not include energy or problem-solving performance (see section 3.4.2). Interest in problem-solving in organisations was one of the key features of the Carnegie School (section 1.2), as was their stress on bounded rationality and heuristic search. Operational Research contains expertise in simulation modelling and heuristic search algorithms (which we draw upon in Chapter 6, in ways reflected on in Appendix F), and has applied its tools and techniques for problem solving in organisations. No one else has attempted to fill the "structural holes" (Burt, 1992) between all these areas - Baker and Quinn's (2007) energy model omits culture and groups for instance (see Chapter 4), and all that they link to - so success would constitute a contribution to knowledge. Equally, identifying previously unforeseen problems in relating these areas would also be a contribution.

Armed with this network we can see how we connect to empirical work: Cross and Parker's social network data collection and interviews; Ryan and Deci's laboratory experiments; Collins's theoretical sociology based on various secondary data sources; ethnographic studies of communities of practice. There are also various studies on social capital and on diffusion of innovations. The empirical grounding may be indirect, but it is there, and it should raise confidence in the value of our project.

Raising confidence in the execution are our links to the standards of simulation modelling in Operational Research, and to other modelling experience - especially that using the Axelrod Cultural Model (see sections 6.2, 6.3 and 8.2).

Future tests of this research would include attempts to reconstruct our models and replicate our results, as well as attempts to produce models by other means for similar ends, and extensions of the work. Such replication is thought “one of the hallmarks of cumulative science” (Axelrod, 2006), but Latour (1987) questions whether it is particularly common now in natural sciences where the expertise, facilities and time are rarely affordable. In the literature on agent-based social simulation actual attempts are certainly rare, and not without their problems (Axtell et al, 1996; Axelrod, 2006). In our own experience, attempts at reproduction led to us identifying a minor bug in a sampling process in Axelrod’s Cultural Model (Axelrod, 1997a, chapter 7; 1997b), and an erroneous description of the calculation of performance in March’s much-cited model of organisation learning (March, 1991) - made worse by a chart that started its scale at 0, despite the model producing some negative output values. An attempt by several experienced modellers to replicate eight published agent-based models “identified problems with respect to ambiguity, gaps, and even errors in the published descriptions, as well as subtle differences between how different floating point systems calculated...” (Axelrod, 2006). They found three decreasing levels of replication:

“‘numerical identity’ in which results are reproduced precisely, ‘distributional equivalence’ in which the results cannot be distinguished statistically, and

‘relational equivalence’ in which qualitative relationships among the variables are reproduced.” (Axelrod, 2006)

Practice in replication also builds capability for constructing one’s own models in the future, and extending the work of others. Axelrod’s prescription for progress in social science simulation is “methodology, standardisation, education and institution building”. Our experiences would add the importance of making code available to others - on the web as Axelrod did for his cultural model (Axelrod, 1996a) or on request as March did to one researcher who helpfully then reproduced March’s formulae in his extensions (Rodan, 2005). Re-engineering a model from its author’s description is a good verification exercise, and producing one’s own model to serve a purpose addressed by another’s can reveal the value of both. But when the results fall short of numerical identity, comparing definitions and algorithms in the code is instructive and relatively quick once one has some idea of what one is looking for.

Finally there is the question of how we feedback into the literatures we draw upon. As we noted above in 5.3 simulation modelling as coalition formation can identify inconsistencies and ambiguities in an author’s presentation of their ideas, tensions between authors, and unanticipated and unwanted logical implications. In stochastic simulations it can trace the distributions of outputs, and in complex models it can reveal interdependencies between variables and sensitivities to initial conditions. Our findings may be presented to the authors we drew upon, and to others working in the same areas. In addition, we can return to the literature with fresh questions in mind, and seek out further works by these authors. A degree of validation of this project comes through finding that previously unseen material fails to introduce more

tensions into our coalition, though current absence of tensions is no absolute guarantee of future absence. Confidence in a model or in a coalition can be raised, but not to an absolute value.

If simulation is a means of theory development (section 5.3), what denotes good theory? In a much-cited paper Weick (1989) argues for a focus on *plausibility rather than validation*, and the raising of *possibilities, not predictions*. When we present to another person, four reactions substitute for validity, the social scientist's equivalent of significance tests:

- “That’s interesting” (a moderately strong assumption is disconfirmed);
- “That’s absurd” (strong assumption disconfirmed);
- “That’s irrelevant” (no assumptions activated);
- “That’s obvious” (strong assumption confirmed).

Other reactions include:

- “That’s connected” - commenting on relations to other thoughts;
- “That’s believable”;
- “That’s beautiful” - though aesthetic reactions are more common in mathematics;
- “That’s real”.

This latter reaction can be the occasion of performing a reality check which protects against shifts:

- from “that’s interesting” to “that’s in my best interest”;
- from “that’s obvious” to “that’s what managers want”, or;
- from “that’s believable” to “that’s what managers want to hear”.

But “that’s real” can also represent a shift itself to “that’s the power system I want”.

Weick sees theory construction as “disciplined imagination”, a process likened to evolution by natural selection. Through use of the imagination we create alternative versions of existing theory, thereby introducing variation. Discipline - including tests of consistency and plausibility - provides selective pressures so that only the fittest survive.

Simulation aids this process in both respects. As the philosopher Dennett has put it, “What you can imagine depends on what you know.” (Pyke, n.d.) Indeed, elsewhere Dennett has described how John Conway’s cellular automata, the Game of Life, acts as a “tool for thinking about determinism”, since experiencing it expands one’s imagination for thinking about this philosophical issue (Dennett, 2004). Closer to our purpose here, simulation’s power for exploration and experimentation helps us generate new conjectures for testing. The rigour and precision of coding, together with the demonstrations of logical implications, discipline us in our creation. While the modelling process, as a tool for facilitating dialogue, adds the selective pressures provided by participants - who may include those imbued with the values of quantitative or qualitative research.

5.6 Which simulations make for good coalitions?

Given we want a simulation to become a part of these actor networks or coalitions which properties of a model will help us? Many of them come with a model being simple:

- Being bug-free, and easy to maintain
- Speed of development and modification
- Short runtime - ideally as close to instantaneous as makes no difference to those interacting with it
- Ease of use
- Intelligibility
- Ease of replication
- Ease of adaptation to participants' purposes

Note the last point - a stable coalition is not guaranteed, and flexibility on the part of the modeller as well as the other participants may be needed if a model is to be produced which participants can buy into. As actor-network theorists' research on the success of innovations has put it, "to adopt is to adapt" (Akrich et al, 2002). If consensus can be found between the theories and studies participating in our network, then ultimate modelling success comes when the work represented by a simulation model becomes treated as a black box - a unified module taken for granted by its users, and incorporated without further thought into new research. The few attempts at replication and the problems encountered in this so far suggest most simulation models are some way off this ideal.

Several authors extol the virtues of simplicity of models (Robinson, 2004; Pidd, 1996), but note this must be set against the need for some level of complexity to meet the purpose of the model (Edmonds & Moehring, 2005). If modelling is to promote understanding among participants whose distinct mental models have yet to be expressed, we cannot speak of a single, clearly identified purpose for a model - the modeller may initially be faced with a “mess”, and there may be multiple paths leading to rival coalitions. But the demands of communication and group decision making probably call for simplicity more often than not.

Building on Weick’s (1989) recommendations we might propose the quality of theory varies with:

- the accuracy and detail present in the representation of modelling participants’ mental models;
- the number of and independence among the variant models and scenarios that attempt to enhance understanding;
- the number and diversity of selection criteria used to test these models and scenarios.

This mention of diversity seems to call for complex models and complex experiments. But Weick cautions that we need to focus on “middle-range theories” if the process is to be kept manageable. In addition, the complexity of the subject matter forces us to employ representations such as metaphors. So we conclude that simplicity,

abstractness and employing metaphors are no drawbacks to simulation modelling in the social studies.

This completes our discussion of what makes simulation suitable for theory development and coalition building among theorists.

5.7 Comparing simulation approaches

Given that we want to use simulation modelling to develop theory about energy, which form of simulation modelling should we choose? We consider three types: agent-based simulation (ABS) (Axelrod, 1997a); discrete-event simulation (DES) (Robinson, 2004), and; system dynamics (SD) (Sterman, 2000).

Cross and Parker (2004a; 2004b, chapter 4) identified individuals as having energising or de-energising characteristics when they engage in social interactions. This suggests we must model people - either as specific agents or in aggregate as populations - and we must model them by type - for instance, with a three-way type of “energisers”, “de-energisers” and “neutrals”. Interactions between agents of different type can be handled by ABS, while SD models interdependencies between different populations. But if we wish to represent different cultural attributes as well, things become too complicated for SD. It is possible to model one stock or population for each energising type combined with each combination of cultural attributes, but the numbers of stocks involved mean that macros would be needed to create and modify systems for modestly high settings: $3 * q^F$ stocks, where q is the number of values per attribute, and F the number of attributes. This is before we even consider adding

energy, networks and groups to the model. By way of illustration Appendix A contains a system dynamics version of Axelrod's Cultural Model (1997a, chapter 7; 1997b) - originally created as an agent-based model - together with some speculation on how energy might be added to it in a manner analogous to what we will do in Chapter 6. We find there that examining the system dynamics model can teach us something about the role of variability from stochastic processes in the agent-based version, but the complexity of the system dynamics model soon makes it an unwieldy tool.

Our desire to model several different concepts in the one model - in ways we have yet to work out - creates problems for DES as well. DES proves useful when one specifically wishes to represent realistic durations and times of occurrence - such as when one wishes to understand waiting times in a queueing system. If energy relates to the rate at which one performs some activity (as in Ryan & Deci's (2000) concept of intrinsic motivation), this might suggest the representation of timings was important. But rates can be approximated by modelling discrete time steps and when models are more abstract in their timings, or when processes take fixed durations, the apparatus of DES - maintaining and computing lists of events - become an overhead a programmer does not need. Off-the-shelf DES packages such as Witness or Simul8 can handle this for the modeller, but they make harder the programming of interdependencies between the entities or agents - a purpose for which these packages were not designed. When one has only a vague idea of the way to model the concepts one is interested in, rapid development and revision of code is important, and so we rule out DES as well.

Given how many of the social simulation models referred to in Chapter 3 were agent-based, it should come as little surprise that we settle on agent-based simulation modelling for our project. Agents can be heterogeneous - each agent readily acquiring values for attributes different to those of the other agents. Attributes can include cultural traits, rules of behaviour, and constraints due to geographical location and social networks. Although one has to engage in programming computer code much earlier than with commercial DES and SD packages, it is relatively easy to add new attributes to agents, and to add new types of agent as and when one thinks of them. Agent-based simulations model individual interaction events between agents - the so-called micro-sociological level we find in Collins's Interaction Ritual theory (Collins, 1981; 2004), but are popular for their emergent patterns - perhaps leading to better understanding of meso- and macro-level phenomena (i.e. groups and societies) (Sawyer, 2005, chapter 8). For these reasons, we will adopt the agent-based approach for our own models in Chapter 6.

5.8 Summary

“The trouble with agent-based modelling is that with enough parameters you can prove anything you like.”

(A professor of OR in response to an earlier agent-based modelling paper of ours.)

It should be clear from our lengthy presentation of an Interpretivist paradigm that we do not feel we have to be in the business of “proving” things. “Proving” things with an agent-based model is probably not as easy as introducing extra parameters to fit

statistical models to empirical data. A common characteristic of popular agent-based simulation models is the surprise felt on the part of the modeller at the emergent, macro-level patterns. There is no intention to *prove* (beyond doubt), but rather to *probe*, to explore - to follow one's curiosity concerning some micro-level interactions.

We are happy to endorse the suggestion that simulation modelling can contribute to theory development in social studies, but we do not limit the ways to those of tests of consistency and sensitivity. The activity of conceptual modelling can facilitate dialogue even when the modelling fails to result in a computer model, and the participants are all data-free theorists. Simulation modelling can assist in the bridging of “structural holes” between theoretical positions, partly unifying existing theories, partly guiding the adaptation of theories. Baker and Quinn implicitly understood the opportunity provided by simulation modelling for developing theories of energy in our sense, as they attempted to form coalitions of various authors plus their own empirical data on energising networks. But we remain unconvinced by their efforts. It is time now to have a go ourselves.

Chapter 6 A family of energy models

6.1 Introduction

We are seeking a better theoretical understanding of Cross and Parker's "energisers" and have argued for using agent-based simulation modelling to this aim. In particular, we want to know how energisers achieve some of the effects identified by Cross and Parker: greater take up of their ideas, larger group formation around them, and better organisational performance with them. Hence we need to encode in a simulation model a notion of an "energiser", and with it a concept of "energy", and the concepts of take up, group, group formation and organisational performance. In the previous chapters we found some of these concepts represented in other researchers' models, but none that combined energy with culture to play roles in interactions, groups and work.

In this chapter we describe a series of steps towards a design of agent-based model in which agents have something representing cultural capital, emotional energy and a social network. The steps are applied to the Axelrod Cultural Model (ACM), which we note in 6.2 has been reproduced, explored and extended by other researchers, thus building our confidence in it as a starting point. Unlike the Baker-Quinn model (Chapter 4) the ACM includes cultural attributes of its agents and these play a role in interactions and in group formation, and thereby determine the emergent behaviour of the system as a whole. But it does not serve as a model of agents with energy. Hence it must be extended. What we build up to is a model in which agents are boundedly

rational in the same sense of the LO-model (discussed in 3.2) in that agents attempt interactions on the basis of limited-size memories. Their memories are derived from first-hand experiences of interactions (local information) rather than the global information about the whole network or population assumed by the Barabasi-Albert model of scale-free network formation. In contrast to the LO-model, our model of social interaction will draw upon the theory of interaction rituals, rather than social exchange theory. The cultural comparisons from the ACM replace the use of the prisoner's dilemma seen in the LO-model.

The extending steps can be grouped into three sets, resulting in three distinct types of energy model, each worth testing Cross and Parker's claims with, and hence taking up three chapters (Chapter 8, Chapter 9 and Chapter 10). The first set gives *each agent* an energy level (section 6.5.2). The second set applies energy *to each cultural feature* held by an agent (6.5.3). The third, involving the most radical alterations, gives agents multi-item memories concerning past interaction experiences (6.5.4). In this type of model there is an energy level *for each experience*, though how much information is included in an experience (participants, cultural activities) is an option. By including past participants in a memory of an interaction, an agent can have an attitude towards another agent, which then determines which pairs of agents attempt interaction in the future.

The most important steps relate to the representation of energy itself, and so we discuss in detail the components of the payoffs from interactions, including one each for an agent's sense of autonomy, belongingness and competence (6.6). Thus we have three different sources of energy from interaction, and thus three different processes

for an “energiser” or “de-energiser” to affect the energy payoff (6.7), but the option exists for combinations of these sources.

6.2 Starting with the Axelrod Cultural Model (ACM)

6.2.1 Why build from the ACM?

We built a family of simulation models as progressive extensions of an existing model – the Axelrod Cultural Model (ACM) (Axelrod, 1997a, chapter 7; 1997b) discussed already in 3.4.2. We want our simulation models to be relatively easy to understand, and this can be made easier by choosing a relatively simple model to start from, and one which is already familiar to a number of other researchers. Carley (1991) presented an earlier model of interaction and cultural spread, but there has been little attempt to build on it. (Other than Carley’s own papers, one exception is Mark (1998)). By contrast, Axelrod’s model has been reproduced by researchers working with Axelrod (Axtell et al, 1996; also contained in Axelrod, 1997a, Appendix A), and reproduced and extended by several groups including physicists (examples: Klemm et al, 2003a; Castellano et al, 2000), social scientists (examples: Grieg, 2002; Shibanaï et al, 2001) and cognitive scientists (Parisi et al, 2003). Each of these groups has faced the challenges of interpreting Axelrod’s description of his model and deciding whether or not they have successfully reproduced it. Where results have been given – either as numbers or in charts – one can try to produce similar numbers from one’s own model. Since the model is stochastic, those numbers will be unlikely to match exactly, but where confidence intervals have been supplied from multiple simulation

replications (for example, Axelrod, 1997a, p.191) statistical tests can be applied to the hypothesis that two programs have produced the same model. To assist such groups further, Axelrod made available online the code for his model written in Pascal as well as a simpler version in both Pascal and Visual Basic (Axelrod, 1996b). Again, since the program depends on a random number generator, we cannot hope to produce exactly the same output if we run it ourselves (unless we could reproduce the exact same stream of random numbers – supplying a file with the millions of numbers used in Axelrod’s experiments was probably not a reasonable request for mid-1990s research). However, the ACM and its extensions are abstract systems, about which we wish to make qualitative conclusions rather than quantitative ones - for example: that there is an S-curve with respect to some parameter (Castellano et al, 2000; Klemm et al, 2003b), rather than that the output at this parameter value had a mean of 0.48 from 100 replications. Supplying code helps ensure that we operate with the same definitions in a model – especially important in the case of output measures. In its absence mathematical expressions may be given to perform the same role – as found in the papers in physics journals (see the group above), but not found in the Journal of Conflict Resolution (e.g. Grieg, 2002). In the light of all this we concluded that Axelrod’s cultural model was a satisfactory starting point for further research, and the technical papers by Klemm et al reliable examples of extensions.

Given that Axelrod’s cultural model is a good starting point for someone’s research, there are a number of aspects to it that make it suitable for our modelling of energy.

In Chapter 1 we established an interest in the “take up of ideas”. As a model of “disseminating culture” or “social influence” agents have cultural attributes which

they may pass on to other agents through social interaction (Axelrod, 1997a, p.151-154).

We identified in Chapter 2 that a theory of energy should relate it to some concept of culture. We can use Axelrod's "cultural attributes" to represent the "cultural capital" ascribed to agents in the theory of interaction rituals (Collins, 2004, p.151-158). They can also represent the dispositions to perform particular activities, the kinds of activities mentioned in the studies of intrinsic and extrinsic motivation (Deci, 1971; Deci & Flaste, 1996).

Like Axelrod we can then use these cultural attributes to define a notion of cultural group. Axelrod's two types of group - "regions" and "zones" - are rather extreme to be considered realistic. The former are clusters of agents linked by having identical features. The latter are linked by having at least one identical feature. But these abstract concepts are easy to define and represent in code, and relatively easy to understand. Hence the above researchers have stuck with them - especially regions - and in the interests of being able to compare our model with others' work we do too.

Similar reasoning leads one to arrange our agents in an abstract, idealised network structure rather than trying to adopt something closer to an observed social network. We employ a 2-dimensional, 4-neighbour lattice grid to match Axelrod's model, then adopt a *complete network* (every agent is physically capable of interacting with any other agent), so that we can focus on cultural relations rather than physical or geographic ones.

The ability to switch in different network structures in a model is another plus of experimenting with the ACM (Klemm et al, 2003b). Other easily manipulated experimental factors include population size, or number of agents (Klemm et al, 2003c), number of cultural attributes or “features”, and number of states per feature, or cultural “traits” (Axelrod, 1997a, p.158-160). Castellano et al (2000) and Klemm et al (2003a; 2003b; 2003c; 2005) in particular have shown the impact of these factors on the level of cultural diversity, or heterogeneity. For example, the size of the largest region follows an S-curve with respect to (q / F) , where q is the number of traits and F the number of features. Different population sizes and network structures have the effect of altering the shape and location of this sigmoidal behaviour. Such easily identifiable patterns can form the base line of our own experiments.

We can also draw upon some of the extensions of the ACM. In particular, Klemm et al (2003a; 2005) looked at the impact of varying the rate of a process of cultural mutation, or “noise” - what Axelrod had already dubbed “cultural drift” (Axelrod, 1997a, p.170). Kennedy (1998) used cultural traits as solutions to some problem, and assigned fitness values to each agent. When these were used to alter the frequency of interaction and imitation events, the ACM becomes a kind of optimisation system. We can use this for the basis of the problem-solving performance we wish to relate to energisers. When fitness is combined with mutation the model acquires a source of cultural innovation. Traits not present in the model population at the start may yet enter during a simulation run. As with March’s model of exploration versus exploitation (March, 1991) the rate can be too high or too low for optimal performance, with a too high mutation rate corrupting any good cultural capital before it can spread, while a low rate means the simulation run may be too short for the

innovations to spread through the population, so this rate becomes another possible experimental factor.

So Axelrod's cultural model provides us with a base model that is familiar to other researchers, easy to reproduce, to experiment with and to extend, and represents in an abstract but clear way agents with cultural capital, capable of social interaction and dissemination of ideas in a network, and forming social groups based on that culture.

6.2.2 The ACM as a model of Interaction Rituals

It is not the only possible basis for a model of social interaction - for example, the LO-model (Pujol et al, 2005) models interactions along the lines of the Prisoner's Dilemma. The micro-sociological theory behind this is that of social exchange and rational choice. But we argued in Chapter 3 a simulation model based on the rival sociological theory of Interaction Rituals (Collins, 1992, chapter 6; 2004) would represent a novel contribution to work on social simulation. Axelrod's cultural model has a representation of social interaction that captures some important features of interaction rituals. Axelrod based his model on two principles: that agents tend to prefer interactions with those who are similar to them culturally (usually called the "homophily principle"); and that in interactions agents become more similar through imitation or the dissemination of ideas and traits (Axelrod, 1997a, chapter 7; 1997b). Derived from Rogers's book on the diffusion of innovations (Rogers, 2003), these principles have their origin in Homans, a pioneer of social exchange theory (Collins, 1992). But the resulting model permits an interpretation in terms of interaction ritual theory as well.

In Axelrod's model agents make comparisons of cultural feature traits (Axelrod, 1997a, p.154-155). In an interaction ritual (IR) agents focus their attention on objects or acts (Collins, 2004, chapter 2). Which objects they are disposed to focus on depends on their cultural capital (Collins, 2004, p.151-154). Interaction participants become mutually aware of whether they are focussed on the same objects. Awareness of a different focus is *de-energising* - the interaction is likely to end prematurely and less likely to be repeated. Axelrod's interactions continue to a second feature comparison only if agents shared a trait in the first feature compared. Awareness of a common focus of attention is *energising* - the objects focussed on become charged up with emotional significance for those participants (Collins, 1993; 2004, p.49, 81) - and in the ACM features that match retain their traits. But if an IR event begins successfully and participants feel energised by the encounter, a new object focussed on can become associated with the event, even though some of the participants may have been unfamiliar with it. This new object can become charged up and added to their cultural capital. Similarly in the ACM if the first feature comparison has succeeded, but the second feature compared does not match, one agent can acquire the trait of the other for that feature. In effect the first agent imitates the second. New cultural capital has been acquired and may determine which objects are focussed on in future IR events. Just as in IR theory the objects are symbols of group membership, so in the ACM the acquired traits form the basis of future interaction and determine the success of feature comparisons with particular partners. In Collins' theory groups are apparent in the repeated patterns within the IR chains (Collins, 1990, p.40), with the IR events' success both causing and being caused by similarity in cultural capital

(Collins, 1981, p.999). In the ACM groups of culturally similar agents emerge as regions.

Thus both interaction rituals and the interactions in the ACM can be viewed as a kind of matching game played between participants. Unlike the Prisoner's Dilemma there is no competition within the interaction game - participants depend upon each other for their payoffs. But competition may exist between IR opportunities. An agent engaged in one IR event with one partner is not serving any other partners at that moment, and may be less likely to engage successfully with others if the current IR is particularly energising. In the ACM agents will tend to move in culture-space towards the agents most similar to themselves - with the potential result that they become too distant - too dissimilar - from other agents to be able to interact with them at all. When an agent finds itself remote from all potential partners, it forms a cultural zone in the ACM and until another agent comes close enough to dissolve the zonal boundary the isolated agent will have no more hope of successful interactions. Such an agent has lost out in what Collins describes as the market for interaction ritual opportunities and ritual solidarity (Collins, 2004, p.149-158).

Collins also acknowledges the importance of material resources in this social game (Collins, 2004, p.160-163, 171-174). Interaction rituals need venues - typically with devices such as walls to divide members from non-members. Their participants also need to possess the physical embodiments of the objects they wish to focus on, such as the trappings of wealth and status, and many rituals have an entrance fee. Lack of the material resources can exclude one from participating in these rituals. But as noted earlier, the interaction possibilities in the ACM can also be biased according to some

extrinsic, non-social source. Kennedy's fitness functions for cultural attributes could represent the material benefit or cost of the cultural objects focussed on.

So to sum up, Axelrod's cultural model represents not just an interesting agent-based model in its own right, but also a crude encoding of interaction ritual theory. We thus choose it as the base of our energy models.

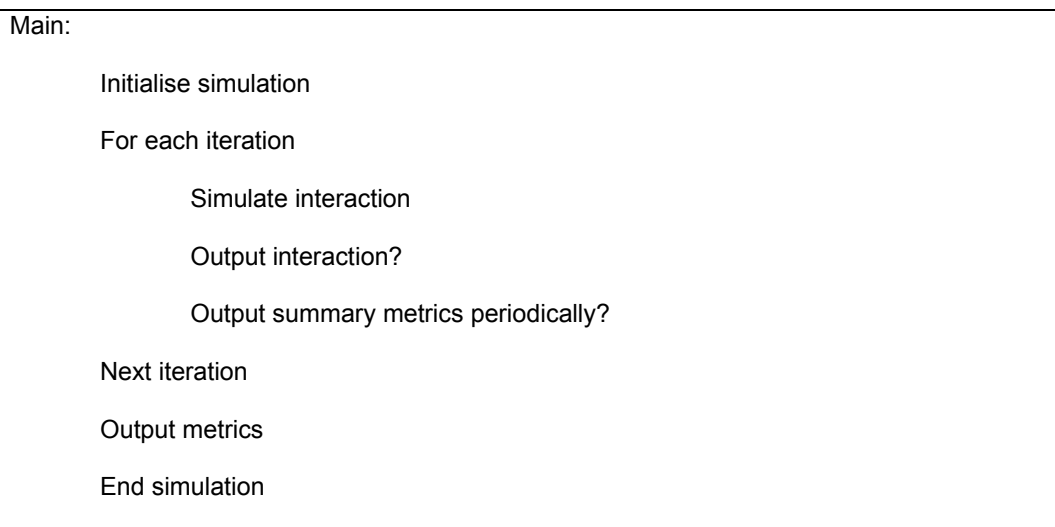

Figure 12 The basic structure of our base model – a version of the Axelrod Cultural Model

6.3 The base model: a version of the ACM

The base model and all models derived from it have a basic structure (*Figure 12*) that includes: setting up or initialisation of the simulation; a number of iterations, in which a single interaction attempt is simulated, and; the calculation and output of metrics – especially at the end of the simulation run.

Setting the simulation up (*Figure 13*) involves defining the population and its agents and giving initial values to their attributes. A little notation will help later on. Let N be the number of agents in the population. There are no birth or death events in this simulation, so the population size does not change during a simulation run. Using the notation of Klemm et al (e.g. 2005), let F be the number of features per agent, and q be the number of traits – the possible values each feature can take. For simplicity, we assume individual features do not differ in the number of traits they may take. We also assume agents do not differ in the number of features they have in their cultural capital, nor in how many traits their features may take.

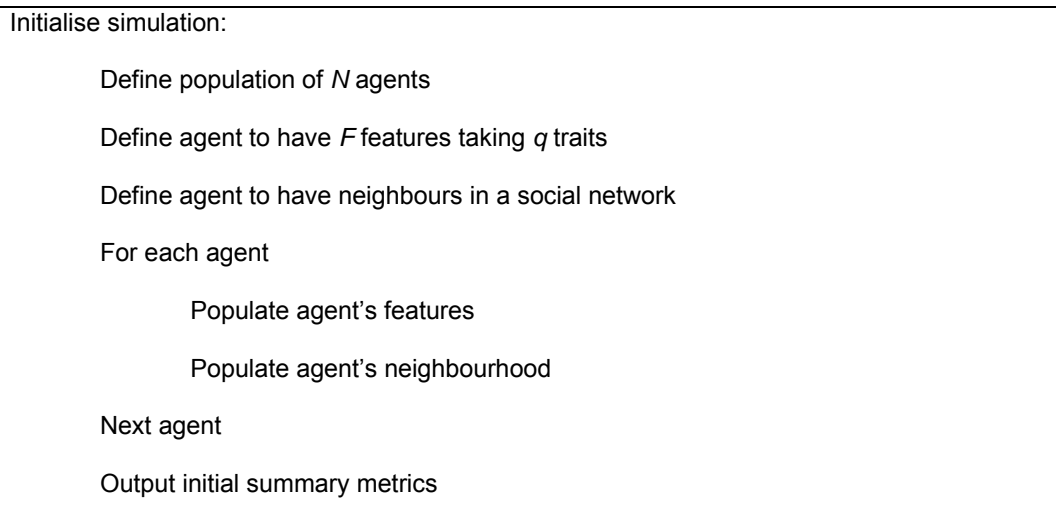

Figure 13 Simulation initialisation in the base model

Agents are located in a network structure. This *geography* constrains who is physically capable of interacting with whom, quite apart from their disposition to do so. Axelrod (1997a, chapter 7; 1997b) considered 2-dimensional lattice grids. His model could give agents 4 neighbours (i.e. the nearest agents “up”, “down”, “left” and “right” - often called a “von Neumann architecture”), 8 neighbours (the first four, plus diagonals), or 12 neighbours (the nearest four, plus the diagonals, plus the next

nearest four), but experiments were concentrated on the 4-neighbour version, which is simplest to program and fastest to run with. Axelrod's grids have edges – agents at the edge of the grid will have fewer neighbours – but mentions trying out grids which wrap around so that an agent at one edge (the lefthand edge, say) may link to one on the opposite edge (the right) – so-called *toroid* networks. Klemm et al (2003b; 2003c) have also investigated 1-dimensional ring networks with different numbers of neighbours per agent, “small world networks” (Watts and Strogatz, 1998) and “scale-free networks” (Barabasi and Albert, 1999; see also our section 3.2). For our purposes, however, we tested our model using the original 4-neighbour 2-D grid to ensure we could match others' results. Thereafter we experiment using a complete network, in which every agent is capable of interactions with every other agent. For relatively small populations – say, $N=20$ – this seems a reasonable assumption (e.g. everyone in the building can talk to everyone else). It also removes issues of pre-determined, *physical* network architecture from the list of experimental factors, thus reducing the number of experiments we have to perform. Whatever patterns may emerge during a simulation run in the relations of who actually interacts (successfully/unsuccessfully) with whom, they will not be constrained by some pre-defined geographical structure imposed by the experimenter.

Having determined who each agent's neighbours are we have to also give the agent initial values for their cultural features. Following Axelrod (1997a, p.154) we sample each feature's trait from a uniform distribution of q traits. Since the traits have no particular extrinsic meaning at this stage in this abstract cultural model, this seems a reasonable assumption.

Once agents have been given a network and culture we can calculate who is in a cultural region or zone with whom, and then output summary metrics based on this information (*Figure 14*). This information will also be needed at the end (when we want to know about the change occurring as a result of the simulation run), and the evolution of the model may be studied by outputting this information periodically. We chose to output it another 10 times at fixed intervals after initialisation, making 11 sets of summary metrics.

Output metrics:

- Compute current regions and zones
- Output size of largest region (“RMax”) and largest zone (“ZMax”)
- Output number of regions and number of zones
- For each agent
 - Output agent’s current region and zone
 - Output number of agents in agent’s current region and zone
- Next agent
- Output number of successful interaction events occurring since last output
- Output number of imitation events occurring since last output

Figure 14 Output metrics in the base model

At simulation start, end and periodically in between metrics are calculated and output to worksheet or file.

The most important part of the simulation program – and the most complicated to write – is the simulation iteration itself which involves several processes (*Figure 15*). For simplicity we continue the assumption of Axelrod that interactions involve two and only two participants. Firstly we select an agent to initiate the interaction - called “Ego” in the common parlance of social network analysts (Wasserman & Faust,

1994). We sample an agent from the population assuming uniformly distributed chances of being selected. The selected agent will attempt to interact with one of its neighbours, so again we sample from these with uniformly distributed chances. The agent receiving the attempt is called “Alter”. In a simple model we can assume that Ego and Alter are never too busy to interact when selected.

Now the agents begin their interaction ritual. For the first move a feature is selected (with uniform chance) for the agents to compare traits. In a real-world interaction ritual this would represent the first object to be focussed on, or the first activity to be engaged in - perhaps a choice of greeting (formal/informal/friendly/hostile etc.), though for the sake of compatibility with the ACM our model features may be selected in any particular order. If Ego and Alter do not share traits for this first feature comparison - i.e. if their attempt at interaction fails from the start - the interaction comes to an end and we may pass on to the next attempt. If, however, they do match, the IR may continue. Further features are selected - in arbitrary order but always from those features not yet focussed on during this IR event. Comparisons continue until the first feature is encountered for which the participants do not have matching traits, or all features have been compared, if no mismatch exists. When a mismatched feature has been found, an imitation event occurs. One of Ego and Alter - we may choose either uniformly - will imitate the other by taking the other's trait for this feature. In the IR interpretation it is as if the energy charge that has been built up during the IR by earlier matches now carries over to the first failure to match, and one of the participants will attach that emotional charge to the object focussed on by the other. In this way, new symbols of social solidarity are acquired and added to cultural

capital. For simplicity we assume no further IR moves are made in this event, even though uncompered features may remain.

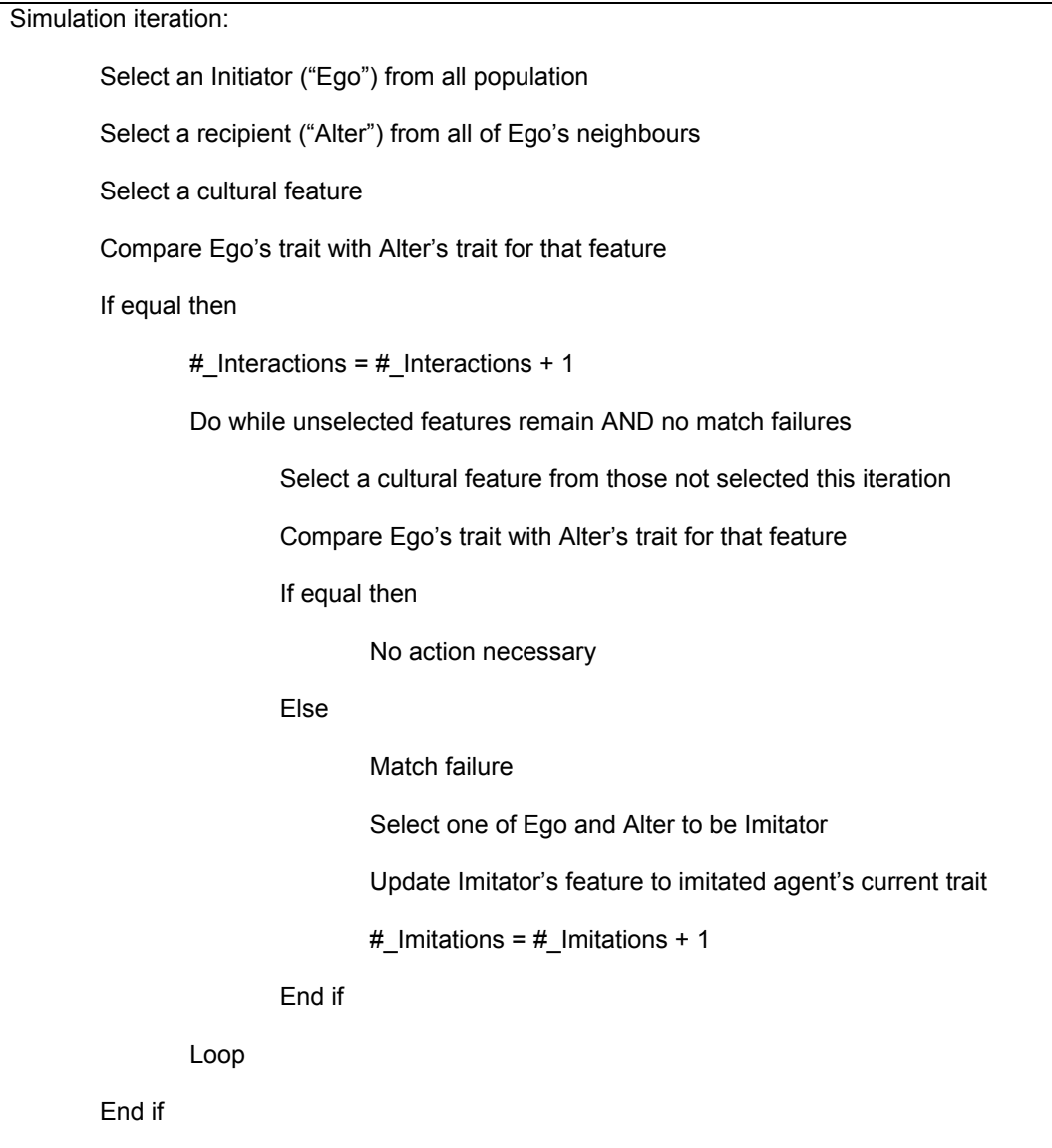

Figure 15 A simulation iteration in the base model

Each iteration is one simulated attempt at interaction between two selected agents.

We count each time an interaction succeeds in its initial feature comparison. We also count each time an imitation event occurs. When output periodically during a simulation run these give an indication of how much interaction activity is going on in

the population, and whether the system has yet converged - as the ACM does - to a static state. Later, extended models will not go static within anything like the same number of iterations, so we must specify a fixed number of simulation iterations, rather than testing for the static state and halting when it occurs.

This then concludes the description of our version of the ACM - our base model - and our interpretation of it in terms of IR theory. In 8.2 we demonstrate the ability to reproduce to a statistically satisfactory degree the homogenisation behaviour identified by Castellano (2000) and Klemm et al (2003c). But while it is a model of social interaction and imitation between agents with culture, it is not yet a model of energy - not in anything like Collins' sense.

6.4 Introducing Energy

In Collins's theory,

“individuals, confronted with interactional situations, move towards those that give the highest payoff in emotional energy... Whether one is most attracted to a church service, a political rally, or an intimate conversation is determined by each individual's expectations of the magnitude of EE flowing from that situation.” (Collins, 1993, p.214)

Thus for a model of agents with energy we must represent in some way not just the energy payoff from an interaction (see next section) but also the agent's expectations

before an interaction. These expectations determine which of the various possible interaction rituals will actually be attempted.

In the base model, there is no representation of expectations. The decision to initiate an interaction employs no intelligence on the part of the agents (i.e. the initiator is selected with uniformly distributed chances). The decisions on who to attempt to interact with and which feature to compare first are likewise based on uniformly distributed chances. Concerning which trait to present in an interaction ritual, agents have no choice at all. Each has in its Cultural Capital just one trait for each feature. (We will later introduce agents with multiple traits for each feature – see section 6.5 below.) On a given topic, each agent has one and only one idea to offer. We might conceive of an agent's trait as representing that agent's view on which trait will deliver the best payoff, but this crude "expected value" is of the 1/0 type. A more realistic treatment of expectations will recognise that they come by degrees. The Baker-Quinn model, for example, models both "energy" and "energising relations" as continuous variables (Baker & Quinn, 2007).

Similarity relations do come by degrees – namely the proportion of features for which two agents share the same traits. But similarity is a reciprocal relation: if agent A shares 0.6 of its traits with agent B, then B shares 0.6 with A. There is nothing in the literature on energy to support the assumption that A will energise with B if and only if B will energise with A. Similarity relations can also be characterised by their transitivity. If A shares 0.7 of its relations with B, and B shares 0.7 with C, the possible sharing between A and C is now constrained to between 0.4 and 0.7. So

similarity relations will not provide us with a proxy for expectations concerning energy.

Energy models then need to record extra information for each agent - in addition to the cultural attributes modelled in the ACM. We can think of this information as representing expectations for the next energy payoff, or memories about past energy payoffs, from which expectations will be derived. Either way we have a numerical attribute that varies in value by degrees.

Modelling energy by degrees is essential to capture another important component of Collins's theory - decay. Emotional energy is "highest at the peak intensity of an IR itself and leaves an energetic afterglow that gradually decreases over time." (Collins, 1993, p.211) The rate of decay, he suggests, has not been measured but "a reasonable approximation may be that it has a 'half life' between a few hours and a few days", unless experience of further IRs during that period alter it.

In our energy models energy levels are reduced over time. "Time" is taken to mean simulation iterations, and one social interaction is processed each iteration. Time is not modelled more realistically, since this seemed to call for the methods of discrete-event simulation (DES). Importing a DES engine into the base model was felt to complicate the programming too much, while reproducing the base model in a commercial DES package not designed for agent-based simulation seemed no easier. The interaction-iteration-timestep equation should be acceptable in an abstract model. Each iteration all energy levels are considered decayed by a fixed proportion of their levels in the previous timestep. The specification of this proportion controls the decay

rate, and the same proportion is assumed for all agents at all time. Thus decay rate - which we refer to in the results chapters by the “half life” - becomes a parameter to our model, and potentially an experimental factor.

Decay gives an explanation of why agents enter interactions - to recharge after their energy levels have decayed. Why do agents then exit IRs? Collins claims agents reach “emotional satiation” (Collins, 1993, p.210). It is “a physiological characteristic of emotions” that emotional arousal plateaus during the IR. This short-run satiation would also reduce the chance of repeated interactions running into one another, though he notes medium-run repetition of rewarding situations does tend to occur.

Our modelling of energy levels attempts to capture these interaction dynamics. For determining which IRs occur we use the difference between an energy level at time of IR and its current, decayed level. The level at time of satiation represents a peak in that agent’s experience of IRs. On the basis of that experience and the subsequent decay, an agent’s expectation of a repetition of an IR is that it will return the agent to the previous peak. Thus the difference between charged-up level and decayed level represents the size of an agent’s expectations - how much energy it expects to gain in IR. In summary:

$$\text{Expected_Gain} = \text{Charged-Up_Level} - \text{Decayed_Level}$$

where

$$\text{Decayed_Level} = \text{Charged-Up_Level} *$$

$$(\text{Decay_Rate} ^ (\text{Time_elapsed_since_previous_IR}))$$

We can then use this Expected Gain to stratify sampling of the components of the next IR event - for example, when selecting agents to initiate and receive interactions. Indeed, in the most sophisticated model (the Interaction Ritual Agents Model, or IRAM, of 6.5.4 and Chapter 10) this is how we will in fact select interaction participants. We build up to it, however, by sampling participants from a uniform distribution in the all the simpler models.

Another alternative to stratified sampling would be to always choose the IR opportunity with the maximum expected gain - or an arbitrary one of the opportunities with maximum gain, if more than one exists. This is seemingly Collins's preferred option when he describes agents as boundedly rational optimisers of expected emotional energy return (Collins, 1993; 2004, p.158ff). Stratified sampling however reduces the contrast between energy-based selections and uniformly distributed chances. Agent energy-maximisers must wait for a future study.

Another alternative would have been to stratify by current energy level. As EE decays with time, this would make recency "an important feature of which IR has the strongest emotional attraction at a given time." (Collins, 1993, p.214) But following Collins's comment on satiation, we wish to avoid making the most likely event a repetition of the last successful IR. Also, low-EE agents would be less likely to enter IRs, and so being unable to recharge, their energy levels will get even worse. We therefore prefer to select agents by expected gain - representing their growing need or desire for interaction.

The modeller then faces decisions concerning the use of an energy attribute. As well as deciding how it determines IRs, he or she must also decide on how IRs affect energy levels. Given an energy payoff from a successful IR we update an energy level with the payoff level only if the payoff level is higher. If a payoff is lower than the current level, the agent is left with the same need as before. If the payoff is lower than that of the previous IR, but sufficient time has occurred since that IR for the energy level to decay below that of the payoff, then the agent acquires the new energy level (from the payoff), which represents that agent's new, reduced, expectation.

This might seem to imply that agents with poor payoff opportunities interact more frequently than those with good ones - since poor opportunities will leave agents still with substantial need for interaction, or expected gain. However, decay means that even poor payoffs will have a chance to update an agent's expectations eventually. Once an agent has been charged from a poor payoff, its expected gain is smaller, since decay is a fixed proportion of an energy level - whether that level was high or low. So of two agents interacting around the same time, one receiving poor payoff, the other a good one, the latter will soon have a much higher expected gain, and thus be likely to interact again sooner when we come to use sampling stratified by expected gain to select participants. Agents repeatedly receiving good payoffs will tend to enter IRs more frequently than those repeatedly receiving poor payoffs.

It is these repeating patterns of IRs - the "interaction ritual chains" (Collins, 2004) - that represent the relations making up social networks. Thus agents repeatedly receiving good payoffs will appear to have more reliable social contacts - and perhaps more of them.

So this concludes our introduction of energy, an attribute that decays over time, motivates agents to recharge it in IR events, and through determining their expectations for those IR events guides their decisions concerning which IRs to attempt or repeat.

6.5 The Interaction Ritual Memory

But what is energy an attribute of? In Ryan & Deci's work intrinsic motivation was directed towards particular activities in experimental conditions (Deci & Flaste, 1996). Cross and Parker focus on people as energisers or de-energisers of others – the cultural activities performed during energising are not part of their numerical data (Cross & Parker, 2004, chapter 4). In Collins's theory emotional energy is associated with particular social situations – including the kind of ritual practices involved, the participants and the objects to be focussed on – as indicated in the quote above (from Collins, 1993, p.214). The “sacred objects” focussed on during an IR and symbolising the group are “charged up” with emotional significance (Collins, 1993, p.212). Elsewhere he describes it as “the amount of confidence and enthusiasm there is towards certain leaders and activities” or an emotional attitude towards a particular social coalition (Collins, 1981, p.994).

To model an attribute of every “social coalition” is not easy. The number of currently possible combinations of participants, activities and objects may be very large. In the approach we adopt – the Interaction Ritual Agents Model (IRAM) – energy is modelled as an attribute of memories of particular interactions. We build up to it in

three stages, using a variety of models, each model applying energy to a different thing: to an agent's whole set of cultural traits; to particular cultural features, and; to particular memories of past interaction ritual events. For each model we can test Cross and Parker's claims, thus giving us three results chapters (Chapter 8, Chapter 9 and Chapter 10 respectively).

6.5.1 Base Model

As detailed above we build our models up from the Axelrod Cultural Model. The memory storage for this model is explained in *Figure 16*. Each agent has F cultural attributes or features. Each feature takes a single value or trait, selected from the q traits available.

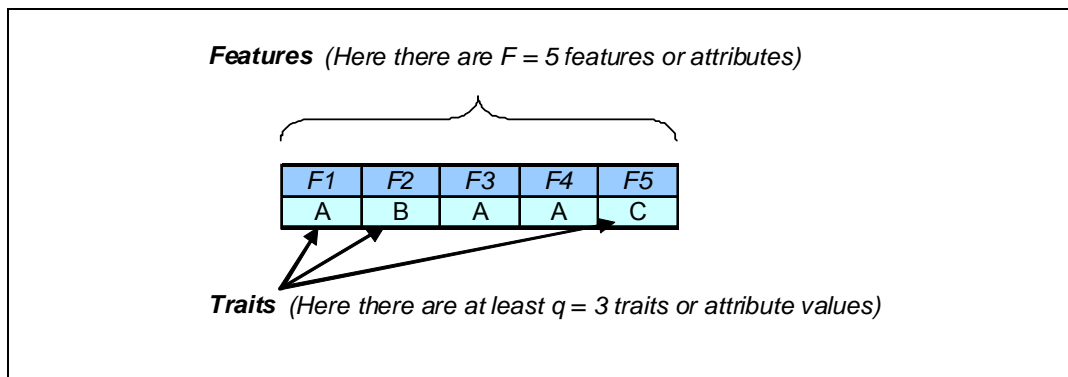

Figure 16 One agent's attributes in the Base model – based on the Axelrod Cultural Model

Each agent has F cultural features, each of which can take one of q traits.

6.5.2 The Agent-Energy Model (AgentE)

In our first energy model each agent has a single energy level, and an expectation concerning how much gain in energy there will be in social interaction (*Figure 17*). In storage terms, we could store the energy level at the previous recorded IR and the current energy level after decay has occurred. In this case, the current energy level of each agent must be updated every iteration, as decay occurs, but the calculation of expected gain is simply the difference between the two energy levels. Alternatively, we can store the energy level at the previous recorded IR and the time (iteration) at which that occurred. The difference between the time of IR and the current IR – or how many iterations have passed since then – tells us how much decay has occurred to the energy charge.

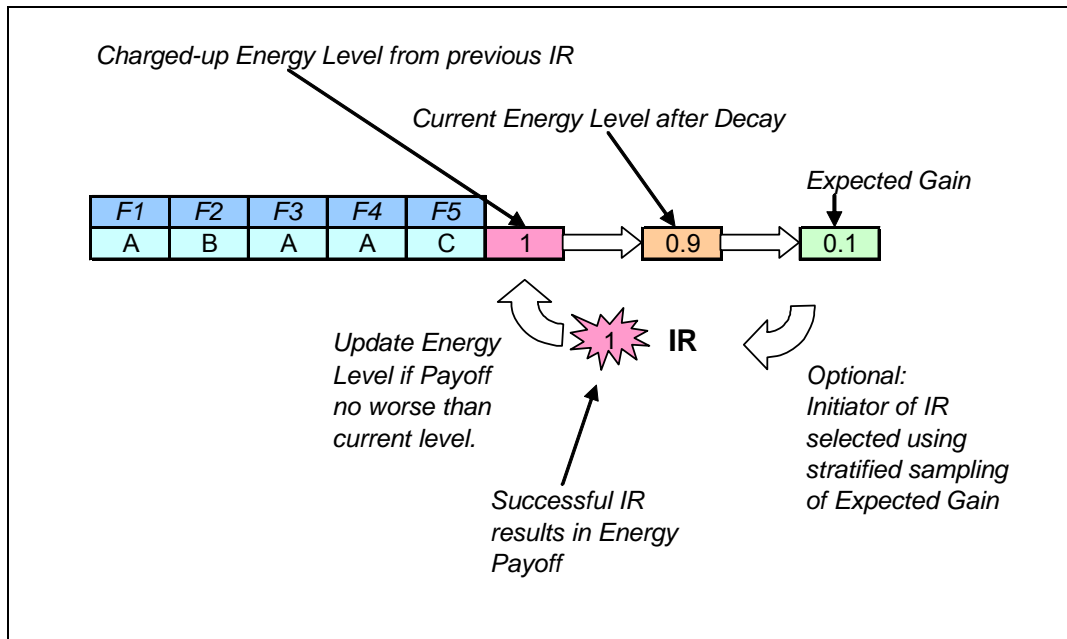

Figure 17 The agent-energy model (AgentE)

As well as its cultural capital each agent has an energy level. In this example an agent received a charge or payoff of 1 in an earlier IR. This energy level has now decayed to 0.9, giving the agent an expected gain of 0.1 from a repeat IR. An agent is selected from the population (optionally using Expected Gain to stratify the sampling). Successful IRs will generate an energy payoff. If the payoff (in this example, 1) is greater than the current level (0.9) then the agent takes the payoff as its new level.

The current, decayed energy level must then be calculated each time we need to know the expected gain:

$$\text{Decayed_Level} = \text{Charged-Up_Level} * (\text{Decay_Rate} ^ (\text{Time_elapsed_since_previous_IR}))$$

This is the method used in our models, though apart from affecting computer processing times the two should be equivalent.

Once we have values for the Expected Gain for each agent in the population we have the option of using them to stratify the sampling of an agent to initiate the next IR, and once chosen we can use them again to stratify the sampling of which of the initiator's neighbours will receive the interaction. The experiments on this model (Chapter 8) found only minor differences in output between using stratified sampling for these two selections, and using unbiased sampling. Consequently we focus on the latter as the simpler process and one easier to compute.

IRs generate an energy payoff (in ways described in section 6.6 below). If the payoff is greater than the current, decayed energy level, the agent is updated with the payoff as its new, charged-up energy level, and with the time of the current IR event. If the IR failed to produce any payoff, or if the payoff produced is not greater than the current energy level, then no update occurs.

Thus the effect of introducing a concept of energy in this first model is to provide a potential hindrance on cultural influence. As in the ACM we pick one of the two participants to be a potential imitator – in this model we will still give them both 50:50 odds. The hindrance comes through a new rule whereby the imitator adds the other's attribute values to its cultural capital only if the interaction ritual generates enough of an energy payoff to overcome the emotional charge on the imitator's current cultural capital. The level of this charge is a function of the time that has passed since the agent was last charged up, and also a function of an energy decay rate - a factor that we can seek to understand by varying it in experiments. We have the option also of using energy - via the concept of Expected Gain - to stratify the sampling of agents when selecting participants for an IR event. This use of energy

appears relatively unimportant in its effects on the model behaviour, compared to that of energy as a hindrance or barrier to imitation. Since the first claim we wish to test is concerned with the take up of ideas, a barrier to this is of great interest.

6.5.3 The Feature-Energy Model (FeatureE)

Stratified sampling based on expected gain re-enters the picture in our second model, in which energy charge is a property of individual cultural features. If features are taken to represent the symbols in Collins's notion of cultural capital, we can say in this model symbols are charged-up with their own emotional energy or significance.

An agent has one energy level for each of its F features. For ease of understanding, as well as faster computation times, we stick to $F = 2$ cultural features, though more could have been used. As *Figure 18* shows, if we maintain separate information on the original charge level and time of charging for both features, we can calculate separate expected gain figures for them. This is then used during an interaction ritual to determine via stratified sampling which feature the agent will focus on first.

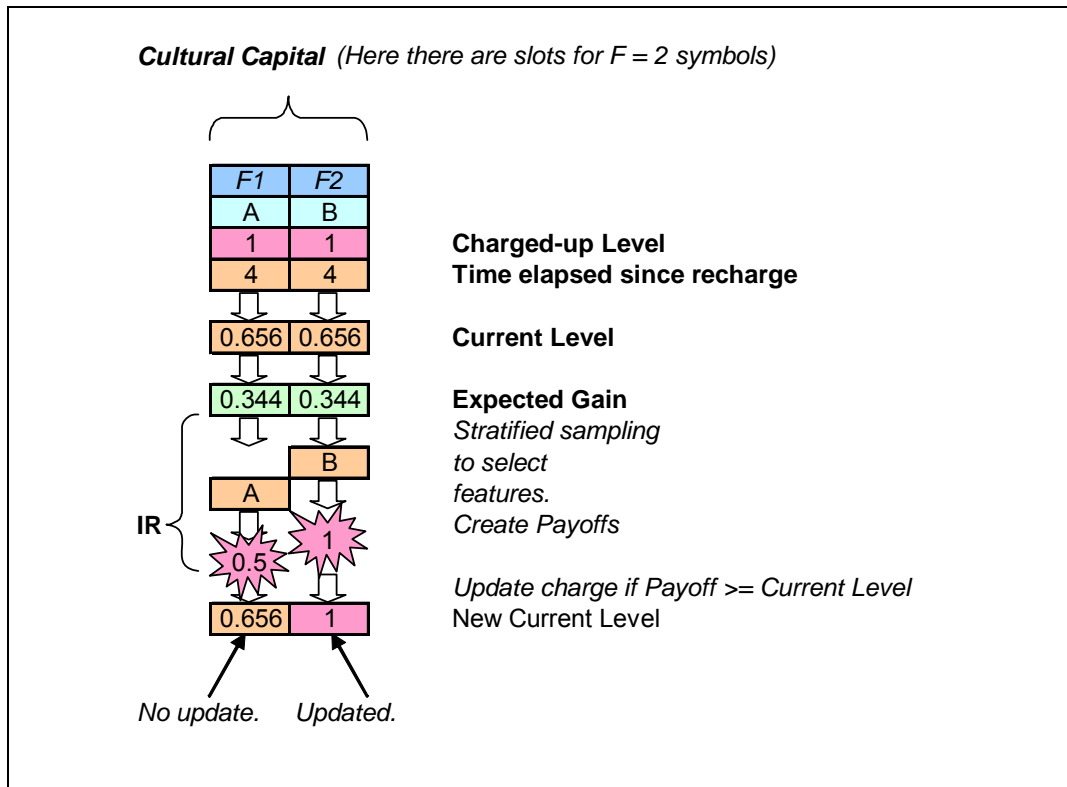

Figure 18 The feature-energy model (FeatureE)

Each agent has an energy level for each Feature – in Collins’s terms every symbol carries a charge. Each Feature is charged up with a separate payoff from interaction, though charge from earlier, successful Feature comparisons (here F1) is carried over to later comparisons. Hence, after a second Feature match, F2 here receives a charge of 1.

During the IR event the features are updated separately. If the first feature comparison results in no match, the IR ends with 0 payoff. If there is a match, however, a payoff is generated and that feature’s energy level compared to the payoff. A superior payoff will replace the old energy level. The IR then proceeds to the next step - the comparison of the next (and if $F=2$, the only remaining) feature. A match here will again generate an energy payoff, but this time we also carry over the charge from the earlier match. So if the second comparison fails, there is still a charge carried over from the first, successful comparison, and hence there is the possibility of the agent’s energy level on the second feature being updated with a charge based on this carried-

over energy. This is how imitation occurs in the feature-energy model. The second feature may have failed to match, but one agent chosen as imitator may try to update its cultural capital for the second feature with the carried-over energy and the other agent's cultural trait. To distinguish between the cases in which both comparisons match and those in which only the first matched we re-weight charge that has been carried-over. Updates are attempted using the total energy payoff from each of the feature comparisons so far, divided by the number of features compared so far. So if a successful match results in a payoff of 1, the first feature comparison results in either 0 (match failed) or 1 (match succeeded), and the second feature comparison results in either $(1 + 0) / 2 = 0.5$ (second failed) or $(1 + 1) / 2 = 1$ (second match succeeded).

Now that features have energy values (charges) we also use them to decide who imitates whom, or which agent's presented trait (feature value) dominates in the IR. Unlike the ACM and the AgentE model where the imitator was selected with even chances, we now stratify sampling by Ego's and Alter's expected gains to select the agent who is imitated. Agents whose cultural capital received poor charge in the past will build up less expected gain, representing their lower confidence in their ideas. Such agents are easier to dominate with your views.

This concludes our second energy model, a model in which energy levels belong to individual cultural features. In Collins's terminology this represents symbols in cultural capital being charged-up with their own emotional energy or significance.

6.5.4 The Interaction Ritual Memory (IRM)

In this subsection we consider a model design in which agents' cultural capital is made up of memories of past interaction ritual experiences, each remembered event having an energy charge. We build up to a model - the Interaction Ritual Agents Model (IRAM) - in which the remembered information includes not only the cultural objects focussed on, but also the participants. Agents do not remember every event they experience - their memories are of limited size, and the maintenance of these IR Memories becomes an important issue. The model was inspired by heuristic search algorithms, and we note some more issues connected to that.

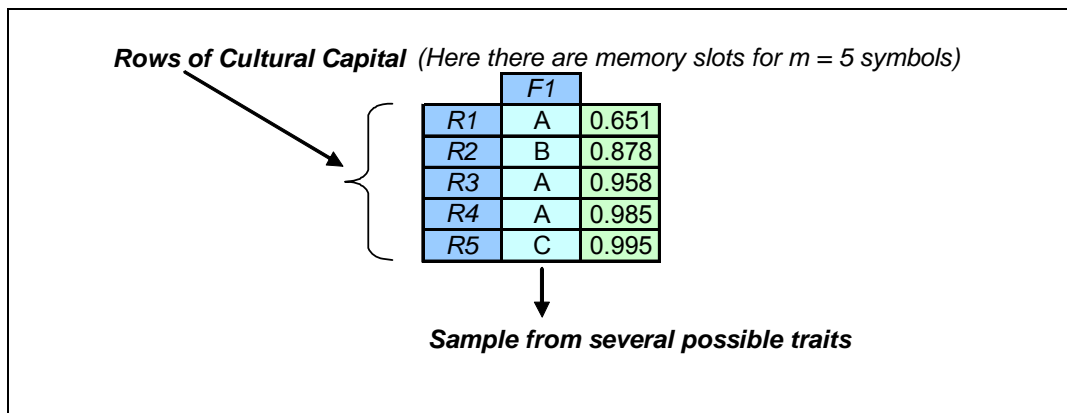

Figure 19 Turning the feature-energy model on its side

Turning the feature-energy model on its side we obtain the idea of an agent holding multiple, rival traits for a given feature.

So far in these models - beginning with the ACM - our agents have had one and only one idea or trait for each cultural dimension or feature. This represents a person with just one way of greeting people, just one view on what to wear this season, or just one club to play golf with. It is obviously a crude approximation to real human agents. Our next innovation is an attempt to overcome this limitation. Consider a model in which the cultural capital of the feature-energy model has been rotated (*Figure 19*). Whereas before we had multiple features, each with its own energy level and expected

gain, now we have multiple rows of cultural capital in our agent’s memory space, for each of which we may obtain an expected gain figure, and thus may use these for stratified sampling of information. The traits in memory all now belong to the same feature, and represent rival ideas in that cultural dimension.

Some traits may be preferred to others – they may have a better chance of being sampled through higher expected gain or through being present in more than one row. But if the memory is of limited size, an agent may know only a subset of the possible traits. A limit on memory size reduces the computational tasks of sampling and updating the memory, and leaves our agents “boundedly rational” in the phrase familiar from the Carnegie School (see section Chapter 1).

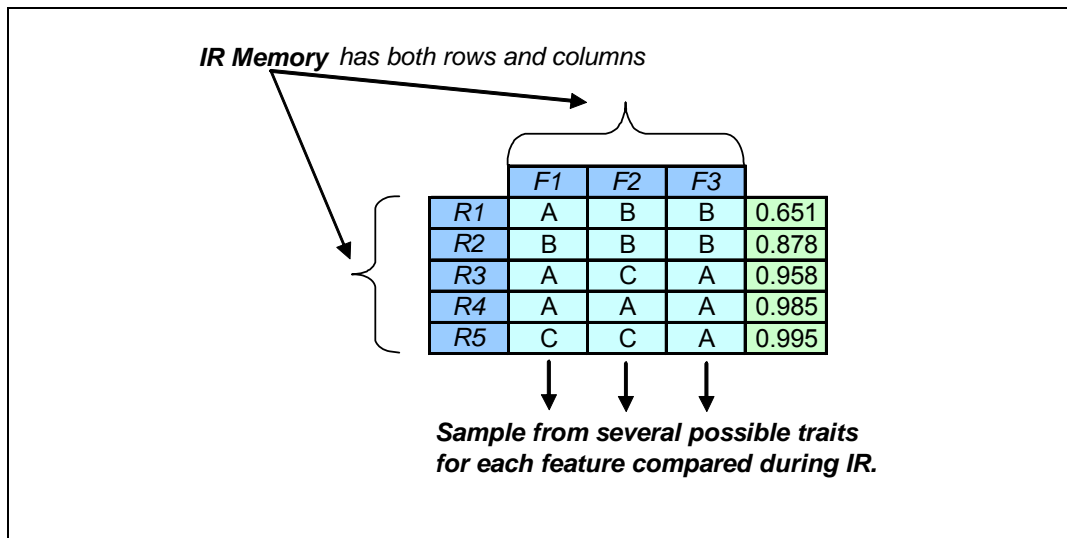

Figure 20 The IR Memory

The IR Memory contains memories of several IR events, each event occupying a single row. Details of the event may include several cultural dimensions or features. For each feature we have several memories to sample traits from. Sampling is stratified by Expected Gain figures calculated for each individual memory.

Collins applies emotional energy to “social coalitions”, something that can have several different dimensions. We therefore seek a model in which we have both multiple features and multiple traits for each feature (*Figure 20*). Each agent in our model has an Interaction Ritual Memory (IR Memory) consisting of m rows of information. Each row represents a memory of an interaction ritual performance event, with the energy level derived from the payoff at that event.

Traits for each feature, or the components of a new IR, may be sampled from any of these rows. An option would have been to select entire rows, in order to keep successful combinations of traits together. We do not pursue this option here, since it would resemble a model with one feature and a vast number of possible traits – one for each possible combination.

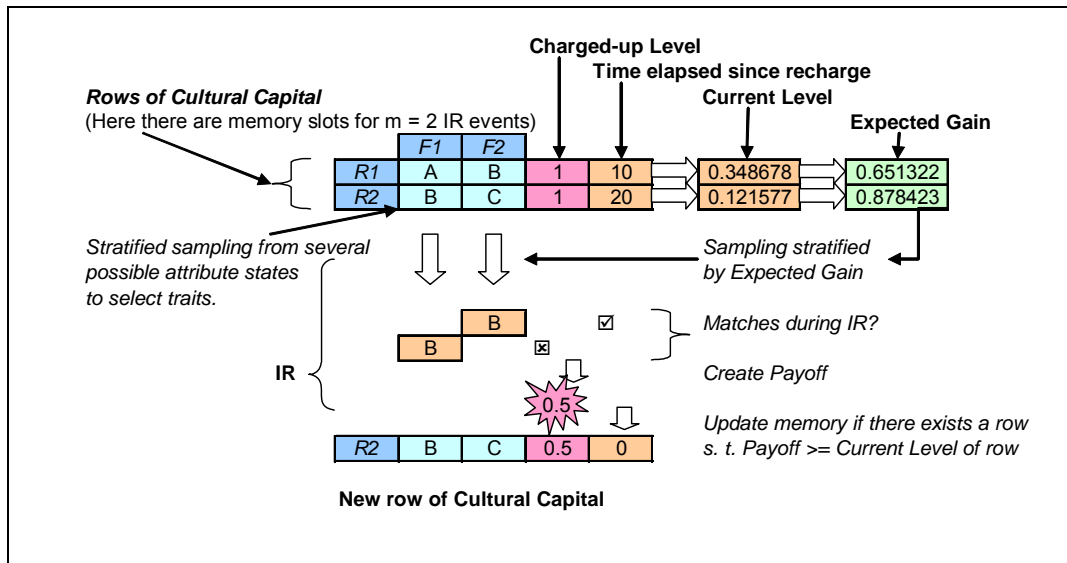

Figure 21 A model with IR Memory

Each IR event remembered involved $F=2$ cultural features. There is an energy level for each such memory.

However, we do update memory a whole row at a time. Following a successful IR, the rows with the lowest energy level are identified. If that level is below the payoff from the new IR, then one of these rows – chosen arbitrarily – is replaced with the details of the new IR (*Figure 21*), including traits for each feature, charged-up energy level and time of occurrence, from which expected gain may be calculated later. This cultural capital represents what was focussed on, or which activities were engaged in, as in previous models.

But another component of the IR event is the participating agents, and these can now be added easily to the IR Memory model. For simplicity, and compatibility with the ACM, we restrict ourselves to interactions between pairs of agents – an initiator of the IR, called “Ego”, and a recipient, “Alter”. This means that energy charge – from which expectations for future IRs are calculated – now applies to information that may include the agent itself as a past initiator. Based on its past success as an initiator it has a degree of confidence in its ability to initiate in future. It also has a disposition to choose some interaction partners over others, based on the list of Alters and the expected gain attached to each event involving them. We can thus sample – stratified by expected gain - from all agents’ IR Memories to choose an initiator, and from an initiator’s IR Memory to choose which of its neighbours will be the recipient of its attempted IR (*Figure 22*).

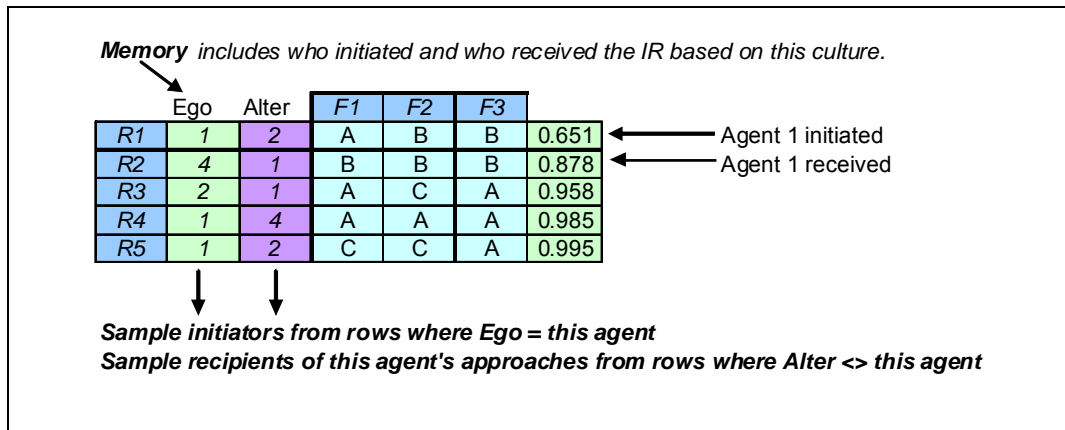

Figure 22 The full Interaction Ritual Agents Model (IRAM)

Each IR event remembered is recorded as a combination of the participants and $F=3$ cultural features.

There is an energy level for each such memory.

By including participants in the IR Memory it can serve two purposes. Firstly, like the memory in the LO-model it holds local (to the agent) information about social networks or, in Collins’s terminology, about recent patterns in the interaction ritual chains - as experienced by individual participants. The agents listed in memories are past interaction partners, but also the neighbours in future social relationships. Secondly the patterns of Ego and Alter agents in the IR Memory record who has been more active in initiating interactions, and who has tended to be more passive. An agent who does not appear in the “Ego” column in its IR Memory cannot be sampled to initiate future interactions. It is dependent on others initiating the interactions it will need for recharging with emotional energy or acquiring new ideas. It represents a person who cannot readily recall themselves as having played the role of initiator, and so forms expectations on the basis of which they will not initiate future interactions.

Our inspiration for this Interaction Ritual Agents Model (IRAM) comes from the world of heuristic search algorithms. In Harmony Search (Geem et al, 2001) a memory is maintained of past solutions to a combinatorial optimisation problem. New

solutions are created through sampling from this memory. If a new solution has a better objective function value than one of the worst solutions in the memory, then it replaces that solution. Over time (iterations) the contents of the memory converge on good solutions, with performance apparently comparable to genetic algorithms. In the IRAM, agents sample from their IR Memories to construct solutions to the problems of recharging energy levels through matching the actions of others while also paying attention to some environmental fitness value. This reflects Collins's description of human agents as choosing IR opportunities so as to be boundedly rational maximisers of the expected emotional energy returns, given some material cost and the opportunity cost of engaging in one interaction rather than another. Part of that return will depend on the actions of other agents - their moves in the IR event - and in common with forms of *swarm intelligence* (Clerc & Kennedy, 2002; Clerc, 2006; De Meyer et al, 2003) each agent in the IRAM draws upon the other agents for help when its own solutions seem less than exciting.

As a *heuristic* search algorithm applied to the space of possible combinations of participants and cultural objects, the IRAM is not guaranteed to find an optimal combination. Indeed by the "No-free-lunch theorem" if it works at all, it will work only for a subset of combinatorial problems in general (Wolpert & Macready, 1997). Whether it works or not in a particular social population is an empirical question. But its appeal lies in its similarity to already proven search algorithms. The search space of different combinations of activities and objects, agent participants, venues and times will soon exceed the possibilities of methods that consider every combination (such as Reinforcement Learning - sometimes used in agent-based models (see section 3.6.2)). Our agents have limited memory to store solutions, and limited time to

perform searches. The performance of other heuristic search algorithms offers hope that such limited computational resources can achieve satisfactory results. Indeed, as noted in section 1.2, Simon and March's contention in the 1940s was that human agents employ heuristics in seeking solutions that are good enough rather than optimal.

Both the LO-Model (Pujol et al, 2005) and the Baker-Quinn model (Baker & Quinn, 2007) claim model agents of limited abilities. In the case of the former this means they select interaction partners from a limited memory – just like the IRAM. In the case of the latter this means they select an energising partner from a limited subset of the population made up with arbitrarily chosen agents. In neither model, however, is the selection of agents related to culture – either to past associations between the agents and cultural objects, or to the future associations of a potential IR event. But in real social interactions, some cultural practices only make sense with particular partners. We choose formal or informal modes of address. We act dominantly or subserviently before another person. Success depends on choosing the right activity with the right person, in the right place at the right time. Committing social faux-pas, stepping out of line, overstepping the mark – these are the events at which getting the combination wrong leads to righteous anger on the part of others towards our transgression (Collins, 2004, p.127-128) and de-energising results for us as we realise our mistake (Collins, 2004, p.50-53). When agents in the IRAM experience a good combination they remember it but ignore the bad ones.

The agents in our models are susceptible to engaging in “groupthink”. As the Axelrod Cultural Model (Axelrod, 1997a; 1997b) demonstrated, agents with a preference for

similarity and a process of imitation will form closed cultural groups with rigid boundaries between them. In effect they become locked into one particular culture as interactions with those in different cultural groups become impossible. If the agents were problem-solving, no new cultural ideas can now be explored, because no new combinations of traits can be assembled during interaction rituals. A source of innovation therefore is needed to break the “groupthink”.

Like the heuristic search algorithms our model has a mechanism for introducing novel ideas to the agent population. When sampling we can give every potential sampling outcome a non-zero chance through giving them an extra, non-zero but relatively small weight. While expected gain figures are relatively large these will dominate the sampling and their corresponding outcomes will have the largest chances. But if expected gain figures are small – either because little time has passed since the prior IR events and the decay rate is slow, or because the charged-up energy levels were poor to start off with – then the extra weights may dominate the sampling. We give each outcome the same extra weight. So, as expected gain figures get smaller, the sampling chances approach a uniform distribution. We can use this technique to introduce a source of innovation to every sampling process, including the selection of initiator, recipient and cultural traits. However, just as Axelrod established results in his experiments without a source of innovation or “cultural drift” (Axelrod, 1997a, p.170-171) – leaving Klemm et al (2003a; 2005) to explore the effect of “noise” on the model – so we start with our extra weights set to values too low to come into play during the simulation runs in our experiments. The effect of innovation must be left to future study.

Another source of innovation cannot be switched off so easily. If our agents sample IR components from several different rows of IR Memory, they have plenty of potential for producing bad mixes from the parts of good, but incompatible, past experiences. We have too much exploration over exploitation. In a combinatorial optimisation system, such as Harmony Search or Genetic Algorithms, the construction of bad mixes is not necessarily a problem. In Harmony Search a bad solution can be discarded at the cost of just one iteration. In Genetic Algorithms selection pressures will remove the bad solutions from the population. But our social agents cannot afford to experiment so much. A person successful in both formal and informal social situations probably does not try the same conversational capital in each. He or she is sensitive to the context. One modelling solution would be to make our agents sensitive to their physical environments. Their selection of who to interact with and how could be biased by contextual information such as which agents are currently in the room, and what objects they are carrying. But if we wish to start experimenting on an abstract model, we do not have a physical environment to include in our model. Another solution would be during IR construction to prefer components that IR Memory includes in association with components already selected from this IR. So given who our interaction partner is to be, we prefer cultural moves that have been used with that person before, and given what move an agent has initiated with we choose from known responses to it. Such a sampling tactic may well be the best answer to this problem, but the modeller would have to decide how often to prefer repeating IR Memory associations, and how often to allow agents to innovate and mix ideas a little. Researchers in Artificial Intelligence have investigated both the use of contextual information to reduce choices, and the use of similarity to previously experienced patterns in order to innovate by drawing analogy (Luger, 2005). But even

if consensus existed within the field concerning how to use them, they would make for much more complicated agent programs. Again, in experiments with a relatively simple, abstract model these are modelling features we shall have to leave out.

We shall also leave out the possibility of remembering unsuccessful IR events. Information on past combinations that yielded failed IRs or very poor payoffs might be used in constructing new IRs that avoided past problems – in a manner analogous to the use of the taboo list in the heuristic search method Tabu Search (Glover, 1989; 1990). This seems too radical a step beyond the ACM and we leave it for future research. We would, however, point out that in the context of our model it is not so much a case of agents remembering negative experiences as remembering non-energising or de-energising ones. Interactions that focus on negative emotions (fear, anger, hate, sorrow) can still be motivating and carry a strong emotional charge. A group of agents becoming aware of sharing these emotions (in the face of a common threat, for example) can build up their sense of group solidarity. Emotional energy in Collins's theory is not restricted to positive emotions. So in our abstract model, what the emotions are need not be specified. In Collins's view (1990; 2004, chapter 3) they would be characterised by the socio-cultural situations evoking them (situations of domination, danger, loss etc.), and in our models cultural attributes are not given any particular interpretation. Only in terms of altering energy levels can interactions be positive or negative in our models.

There was one problem identified in the IRAM that we felt could not be saved for future research. Agents IR Memories had a tendency to converge to a uniform state: m copies of the same type of IR event. Since one of the attractions of the IRAM is the

possibility of each agent having a variety of traits to select from (as well as being acquainted with a variety of interaction partners), this internal homogenisation is not desirable. In heuristic search methods convergence to a single solution is often desired by the final iteration, but premature convergence means a lost opportunity for exploration. A source of innovation – such as the mutation process in genetic algorithms – can re-introduce diversity to the population, but these are variations on existing themes. What we seek is the ability to hold multiple, very distinct ideas on interaction at the same time, without risk of loss. To this end we modified the update rule. Our new update rule (*Figure 23*) encodes a preference for replacing a row that is as similar as possible to the current IR. This greatly improved the persistence of diversity within IR Memory within the lengths of simulation run used in our experiments.

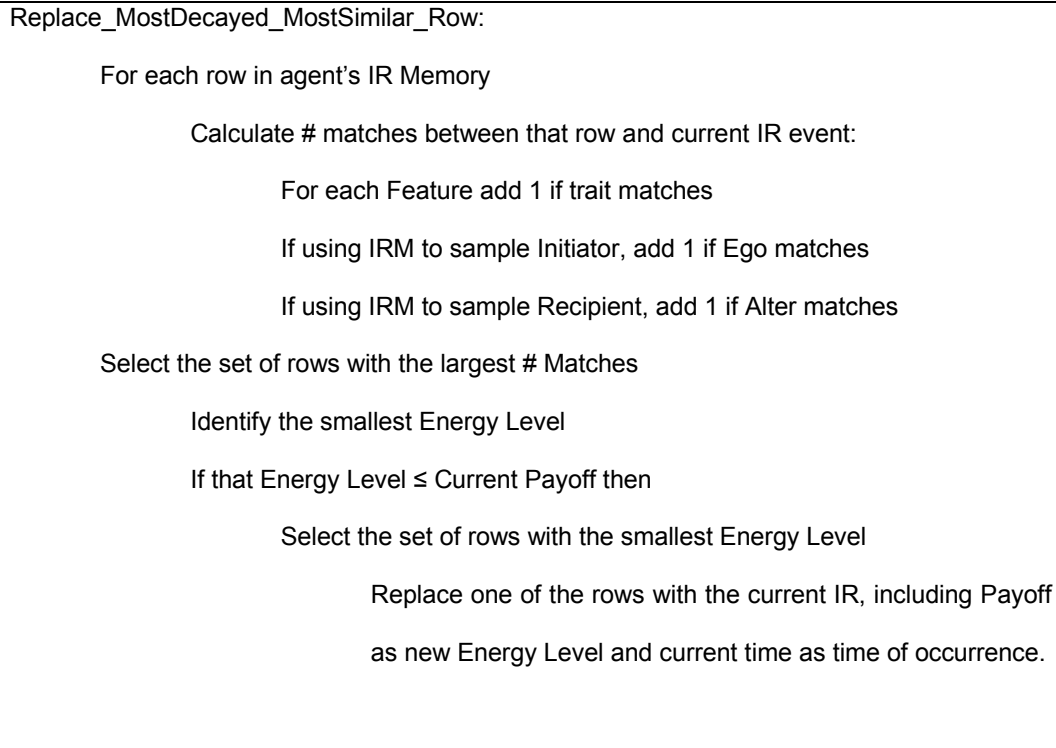

Figure 23 Method for updating IR Memory with the details of a new IR event

If Payoff is sufficiently high new IR replaces one of the rows with the smallest Energy Level, among the rows with the most similarity to the new IR. Note similarity can here include having the same participants as Ego and Alter.

This concludes our discussion of how our energy models use energy payoffs in sampling and updating. What remains is to explain the generation of payoffs themselves, and what it is for energisers and de-energisers to alter these payoffs.

6.6 The A, B and C of Energy Payoffs

From a modeller's point of view we need an energy concept that fits into an explanatory framework of social interactions. Collins's concept has its place in a whole micro-sociological theory of agents and interaction situations. Whether a form

of emotional charge or the feeling of group solidarity it is generated by interactions, and determines what interactions may occur in future, via our expectations for those interactions. Ryan and Deci's work in self-determination theory relates to future activities the outcome of social interaction, via the notion of intrinsic motivation levels. But these activities are not themselves social interactions. In Collins the circle is complete – or the chains of interaction rituals formed.

Quinn has presented one theoretical model that integrates both sources. Using terms derived from Ryan & Deci, “autonomy”, “belongingness” and “competence” are the mechanisms by which energy in agents is generated from “social connections” (Quinn, 2007, p.84). But his model requires an understanding of what have been termed “high quality connections” (Dutton & Heaphy, 2003). If HQCs are “connections made between two people that are marked by vitality, mutuality and positive regard”, it would seem this model is restricted to *positive* interactions. We find, therefore, Collins's theory to be wider in scope and have chosen the vocabulary of interaction rituals in this thesis.

There seems support for relating autonomy, belongingness and competence to Collins's emotional energy, however.

The closest correlate of autonomy would be what happens in “power rituals” (Collins, 1990, p.35). The feeling of being controlled by others in self-determination theory becomes the experience of being dominated. Order-givers gain EE. Order-takers lose it. (Collins, 1990, p.39)

In “status rituals”, on the other hand, the “fundamental feature... is *belonging or not belonging*” (Collins, 1990, p.37, our italics). “Successful enactment of group membership raises EE, experiencing marginality or exclusion lowers it.” (Collins, 1990, p.39) “High degrees of emotional arousal are created especially by IRs that include an element of conflict against outsiders.” (Collins, 1981, p.1002)

Competence may be interpreted as the effective execution of both types of ritual, and perhaps also as an awareness of the material resources that have been presented and expended in order to participate in the interaction. Ritual performances that cost more than was expected suggest poor competence on the part of the participant.

Thus we find the various forms of payoff from interaction rituals provide suitable candidates for feelings of autonomy, belongingness and competence – the ABC of intrinsic motivation. This micro-sociological theory of agents is what we try to represent in our models.

As already suggested by our discussion of using the ACM, a connection can be drawn between the matching of cultural traits in the ACM and the concepts of attention focus and group solidarity in IR theory. An agent who can focus on the same objects as another agent feels a sense of solidarity with that other, and the objects become symbols of their common group membership. The awareness of belonging to something common is the first component of energy we model. *Belongingness* scores are based upon the proportion of cultural features for which two agents matched in traits. As a proportion this ranges from 0 to 1. In line with the ACM, however, a

failure to match in the first feature compared results in both agents exiting the IR event with Belongingness payoff = 0.

Our survey of models of “work performance” (section 3.5) failed to identify a convenient representation of tasks for agents to be “competent” at. As Kennedy’s use of the ACM has indicated (Kennedy, 1998) cultural traits can easily be mapped to fitness values. This has the virtue of being easy to program and debug, and quick to calculate during a simulation run. In view of the relative simplicity of this, and in the absence of a specific scenario to model, we represent the sense of competence using a linear mapping of trait ID numbers to fitness values. The traits an agent presents in an IR event are turned into fitness numbers and averaged across features to produce a single number between 0 and 1. More details of this process are covered in Chapter 8. IR events where agents exit after the first feature comparison has failed are taken to generate no competence score. By adopting a crude, abstract fitness function, we free ourselves up to focus on other aspects of the modelling. Should a more convincing, benchmark representation of work that is easy to calculate emerge in the literature, we will at least be ready with models to insert them into. (We shall return to the question of more demanding benchmark fitness functions for competence in 12.5.3 and F.7.)

To capture the idea of some agents dominating an IR more than others we use their expected gain values to decide who has presented a trait first for each feature. Agents with more autonomy will not wait for the other to lead but will take the initiative. Agents, who are being beaten in the race to make each contribution to the ritual, and feel themselves becoming passive spectators in someone else’s performance, will not experience the IR as energising. We calculate an Autonomy score for each participant

as the proportion of features for which that agent was first to supply a trait. Again this varies from 0 to 1, and IR events that finish prematurely score 0.

Table 2 Energy Payoff calculations explained

Concept	Definition
Failed IR event	A failure to match traits in the first feature compared results in a failed IR event. All participants exit with payoffs of 0 and neither cultural capital nor energy levels can be updated.
Otherwise, payoffs are based on:	
A. Autonomy	Proportion of cultural features for which agent was first to supply the trait.
B. Belongingness	Proportion of cultural features for which participating agents matched trait.
C. Competence	Mean for all features of trait-based fitness values. In the simplest case, trait fitness is scaled linearly, with trait “A” scoring 1 and the q^{th} trait scoring 0.

Our three components of payoff are listed in Table 2. Each component is a number between 0 and 1. We multiply them together to form a single figure – the energy payoff the agent receives from that IR event. Thus we simplify the programmer’s task to dealing with payoffs only in this [0, 1] range, rather than utility values of unbounded range. Standardised, bounded payoffs may also help the model user and experimenter through telling them what not to expect. In addition, in the next section we will apply exponents to each payoff component. This provides a means of weighting the components, so that, for example, Belongingness could be treated as

being more important than Competence. We make no claims to these being the definitive or best representations of the autonomy, belongingness and competence concepts found in the literature. We offer them now as first attempts, and welcome any alternative suggestions that come with arguments in their favour.

The three claims we wish to test are given in terms of the effects had by “energisers” and “de-energisers”. Having established a concept of energy we must now define what these two types of agent are.

6.7 Energisers and De-energisers

Energisers raise energy; de-energisers lower it. That much is implied by the grammar. Beyond this we must decide whether the energy raised or lowered is that of energy *levels*, or that of energy *payoffs*. In addition, we must decide how energisers have their effects, and whether they have them in virtue of some special property – which the experimenter might predefine – or whether being an energiser is an emergent property of the system.

In modelling interaction rituals we have supplied one and only one means of energy levels being raised – that of generating payoffs from an interaction ritual that are superior to current energy charges. Beginning with their questionnaire Cross and Parker (2004b, p.51) only discuss energising in connection with social interactions. It seems safe enough, therefore, to model energiser effects via alterations in the payoffs. Raising the payoff raises the chance of the recipient receiving improved energy levels, and enhanced expectations for future IRs. Lowering the payoff, however, does not

necessarily result in lower energy levels – decay is what does that. But if an agent’s energy levels have decayed enough, even a reduced payoff may update one of them. Initially the newly updated energy level gives rise to no expected gain – energy satiation is in operation. But as the energy decays, the difference between the poor payoff and the current level – expected gain - approaches the size of the payoff itself. In this case, a reduced payoff has led to reduced expectations and reduced motivation to engage in IRs.

One interpretation of “energiser” (and “de-energiser”) would be that they are simply those who generate a sense (or lack of it) of autonomy, belongingness and competence. That is, the energisers are whoever produces the largest payoffs; de-energisers, whoever produces the worst. The payoffs in our models are determined by presenting traits first, matching traits and presenting the best traits in some externally defined sense. All three are outcomes of the model’s evolution during a simulation run – they depend on an agent’s cultural similarity, expectations and current traits, all of which change following interactions. Which agents will succeed here is difficult (impossible?) to anticipate in advance of running the model – and so energisers and de-energisers in this sense would be identifiable only retrospectively. Collins’s discussion of “energy leaders” (Collins, 1990; 2004, p.108) or “energy stars” (Collins, 2004, p.131-133) suggests that they are the products of the system of interaction ritual chains they form part of. Past IR success feeds into future success, propelling a lucky few to the energy elite. But in 2.6 we noted that “energy leaders” are not necessarily “energisers”, and may well de-energise others through over-dominating situations. It is not clear that energising behaviour leads to further energising behaviour, and that an energiser on one occasion will be an energiser on a reliable basis. But we need

some persistence in the identity of energisers and de-energisers – Cross and Parker would struggle to identify anyone as such if there was not this persistence over time. There would be little point to their studies if past knowledge of an energiser did not offer a guide to future energisers. It may be that a simulation model can produce persistently energising and de-energising individuals, but a priori we cannot be sure of this. Establishing such a model would be an exploration in itself, but a necessary preliminary to any further research into the possible effects of energisers on the take up of ideas, group formation and problem-solving performance. So we would prefer not to rely on the simulation model to provide usable concepts of “energiser” and “de-energiser” in this sense.

Instead we introduce another attribute of agents whereby they enhance or diminish others’ payoffs during IR events. Cross and Parker report that “energising interactions are clearly influenced by people’s behaviour, but they are also influenced by certain characteristics of the individuals and the relationships between them” (Cross & Parker, 2004b, p.57). By virtue of differences in these latter, two agents can perform the same behaviour yet produce different outcomes in terms of energy. For example, a vision articulated by someone perceived to have integrity is energising. The same vision given by someone without integrity is de-energising. These characteristics are not part of the cultural exchange during one interaction – we do not need to model them as cultural capital spread through imitation – but longer term, built up over the course of many interactions and having their effect over many further interactions. Within the timescales modelled by our simulations we may be able to ignore change in energiser/de-energiser characteristics, and concentrate on their effects on behaviour.

In applications of Deci & Ryan's self-determination theory (SDT) (Deci & Ryan, 2002) one also distinguishes between activities that one wishes others to perform (such as, classroom exercises for one's pupils, tasks for one's workers, or tests for one's experimental subjects), and the ways in which one goes about trying to get them to perform them. This latter could include the form of words used, tone of voice, or the presence or absence of an extrinsic reward. For example, language which was perceived by the subjects as "controlling" tended to de-energise – through reducing their sense of autonomy. By raising awareness of this among users, they could help others to find other ways of speaking, ones which promoted intrinsic motivation (Deci & Flaste, 1996). Similarly, Cross and Parker advocate making de-energisers aware of their effects on others, and coaching them to act differently (Cross & Parker, 2004b, p.50, 52). So the attributes whereby one is an energiser or a de-energiser are longer term than other behavioural dispositions, but in the face of training not immutable.

SDT research also raises the possibility of contagion – one person using controlling, de-energising language with another causes that other person to use de-energising language (Deci & Flaste, 1996). Imitation might produce this, but it is absent from Cross and Parker, so we will stick with a distinction between energising characteristics and regular, cultural attributes, and only allow the latter to form part of imitation and the preference for similarity.

In the previous section we chose to represent our three sources of payoff with functions that all deliver values in the range 0 to 1. Multiplying them together will produce values in the same range. A program can increase or decrease values within

that range without exceeding it if we raise them to a positive power. We give each agent an “energising parameter” which serves as this power when determining the payoffs of the agent’s interaction partners, and defines whether the first agent is an energiser or de-energiser. A power > 0 and < 1 will increase a payoff. A power > 1 will decrease a payoff. Raising something to power of 1 will, of course, leave it the same – so this represents a “neutral” agent who is neither particularly energising nor de-energising. *Figure 24* illustrates the relationship between payoffs after they have been altered by an energiser/de-energiser, and the payoff values prior to this, for a variety of energising parameter values. *Figure 25* shows the same for just three values of prior payoff: 0; 0.5; 1. Given our definition of the Belongingness payoff above (Table 2), these represent the three possible outcomes from an IR when agents have $F = 2$ cultural features to compare. Obviously interactions that yield no payoff cannot - by this method – be energised or de-energised to any value other than 0. Likewise, the maximum payoff of 1 is unaltered by an energiser or de-energiser. But prior-payoff values in-between can be altered, and *Figure 26* shows how 0.5 can be raised or lowered according to the energising parameter.

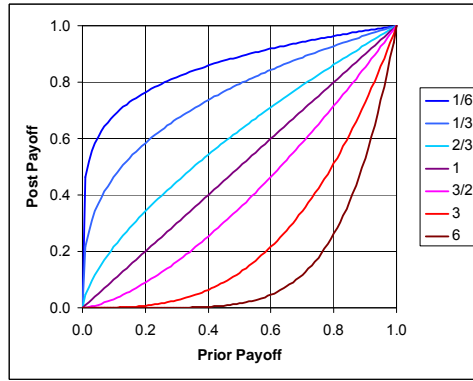

Figure 24 Payoffs pre- and post-energising

Given payoff value prior to energising/de-energising (x-axis), chart shows resulting payoff value after energising/de-energising (y-axis). The post payoff is the value of the prior payoff raised to the power given by the energising parameter. Included here are the effects of three types of energiser (energising parameter = $1/6$, $1/3$ or $2/3$) and three types of de-energiser ($3/2$, 3 , 6), as well as the neutral effect (1).

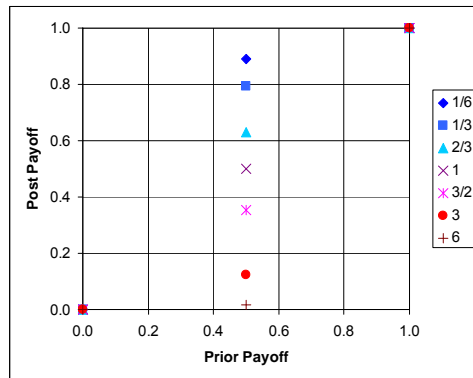

Figure 25 Payoffs post-energising for prior payoffs of 0, 0.5 and 1

Post energising/de-energising payoffs as in Figure 24, but shown here for just three values of prior payoff: 0; 0.5; 1. These are the values possible for our Belongingness payoff when agents have $F = 2$ features.

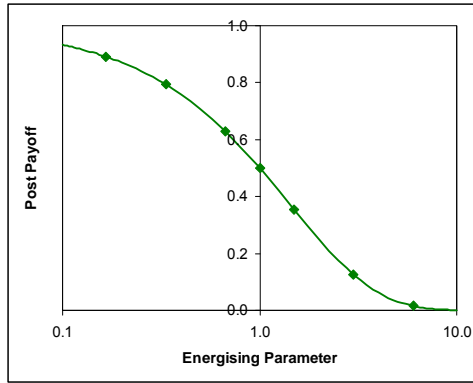

Figure 26 Post energising/de-energising payoff as a function of the energising parameter

Post energising/de-energising payoff as a function of the energising parameter, for a prior payoff of 0.5. This is the only value possible for our Belongingness payoff - apart from the trivial values of 0 and 1 - when agents have $F = 2$ features. Parameter values < 1 energise, or raise payoffs, those > 1 de-energise.

We assign energising parameters to each agent for each source of payoff: Autonomy; Belongingness; Competence. The final definition of payoff then is given by:

$$Ego's_Payoff = A^\alpha \times B^\beta \times C^\chi$$

where

Agent "Ego" interacts with agent "Alter"

A is Autonomy, based on proportion of features where Ego moved first

B is Belongingness, based on proportion of features where Ego and Alter matched in trait

C is Competence, based on fitness score of Ego's traits presented in IR

α is Alter's energising parameter for Autonomy

β is Alter's energising parameter for Belongingness

χ is Alter's energising parameter for Competence

In this form, the combined payoff function resembles the Cobb-Douglas utility function familiar from Microeconomics textbooks and various historical sources (Varian, 2006; Lloyd, 2001). This is perhaps the simplest function that will represent “well-behaved preferences” - i.e. those that are both monotonic and convex - and any monotonic transformation of it will represent the same preferences (Varian, 2006, p.63-65). This latter property, however, may be of little interest with respect to energy payoffs. The literature on energising and autonomy, belongingness and competence does not restrict us to monotonic transformations. In particular, at this stage we will consider the possibility of energising capabilities that affect one of the components the payoff function but not the others. This represents, for example, an energiser having greater ability to improve one’s sense of autonomy without anything being implied about their affect on one’s sense of belongingness. So despite the formal similarity to the Cobb-Douglas utility function, we cannot employ the analysis performed on that function here to determine whether this is the best representation for energy payoffs. As with the payoff function itself, our use of exponents to represent energising / de-energising characteristics is a convenient first assumption, not the last word on the matter.

In our experiments we employed just 7 values for the energising parameters (1/6, 1/3, 2/3, 1, 1.5, 3, 6), and for simplicity applied them to just one source of energy payoff at a time. So during a simulation run an energiser could energise just one of Autonomy, Belongingness and Competence payoffs. We also restricted the number of sources of energy payoff, mostly focussing on Belongingness since that places us closest to the matching game in the ACM, and also since that seemed the most important energy concept in Collins’s theory. Setting an energising parameter to 0 switched that energy

source off in the sense that we then computed Autonomy and Competence scores as 1, and Belongingness as either 1 or – in the case of a failed IR – 0. However, further research could try more complex payoff functions, perhaps even using the multiple energising parameters to adjust the relative balance of the three energy sources in providing the final payoff.

Using these energising parameters, then, we can control at the start of a simulation run, for a chosen source of energy payoff, which agents are energisers, which de-energisers and which neutral, and also how strong the energising/de-energising effects are. The strength of these effects becomes an experimental factor in experiments which compare a single energiser/de-energiser to a population of otherwise neutral agents. It is time now to discuss what our experiments can test.

6.8 Summary

We have introduced a family of agent-based simulation models of agents with energy, discussed their derivation from Axelrod's Cultural Model and Collins's theory of interaction rituals. We have also given some justification for each model feature or parameter. We cannot promise to have presented the definitive representations of cultural attributes, social interactions, energy payoffs, or energising capabilities. We offer them as starting assumptions, and invite suggestions for improvements. Proposing a plausible model of agents with energy is better than proposing no model.

Chapter 7 Testing Cross & Parker's Claims

7.1 Introduction

Following on from the description of the family of energy models, in this chapter we describe their use. We identify three claims from the literature for our purposes (7.2). These concern three output metrics: the take-up of ideas; the size of groups, and; the problem-solving performance of the population as a whole. We can then experiment by varying a number of model parameter values as factors to find out what impact this has on the output metrics (7.3). In particular, we can test the claims at each combination of parameter values.

The claims test metrics are not the only outputs. Some output metrics (based on entropy) only apply to the multi-row IR Memory model and IRAM, so we leave discussion of these for the chapter dedicated to experimental results from these models (section 10.5).

In the final sections of this chapter we cover instead two other topics. There are some technical issues we encountered during the development of the models that seem worth mentioning, since they will be faced by other developers of agent-based models (7.4). Then we conclude with a discussion of visual outputs (7.5): screen displays and special kinds of data output designed to help understand what is going on inside the simulation models - a form of “verification and validation”, or building of confidence

in the model. We cannot take the reader through the history of debugging this model, but we can at least describe some of the tools used for debugging.

7.2 Testing Cross & Parker's Claims

We need to define three output metrics – one for each of Cross and Parker's claims.

The first is straightforward:

“Our results suggest that those who energise others may be more likely to be heard and to have their ideas put into action... Energisers are better at getting others to act on their ideas within organisations...” (Cross & Parker, 2004b, p.54)

We already have models in which agents take up ideas from others. To Axelrod's model of cultural influence we have added a role for energy, and thereby made it possible for energisers to affect the process of take up or imitation. In the energy models imitation can only occur if the IR generates an energy payoff to an agent sufficient to beat the current energy charge on that agent's existing cultural capital. When this happens, we can count it as one case of another agent being imitated by the first. Our hypothesis is that energisers – those with energising parameter (exponent) < 1 – will be imitated more often than those with higher values of the parameter. Thus “Frequency of being imitated” is our output metric for testing claim 1.

Claim 1: Energisers are imitated more frequently than non-energisers, and de-energisers are imitated less frequently.

We take our lead for a second claim from Cross and Parker report that energisers attract more interaction partners (Cross & Parker, 2004b, p.54-5). Given a choice, people prefer to interact with energisers, and interact with de-energisers only when they have to. Of our family of energy models only in the IRAM do agents have the ability to express preferences as to who they interact with. For simpler models agents select partners without preference, and interaction alternatives differ in the expected outcomes. An unsuccessful or poorly energising interaction will leave an agent needing further interaction to recharge its energy levels, and successful, energising ones are likely to involve some other partner - one with more similarity. Due to imitation, over time the partners an agent enjoys successful interactions with will become more similar to that agent and to each other, and a cultural region will emerge. In the extreme case of the ACM, once the system has reached a static state, agents have chance of successful interaction with and only with those in the same region as them. Thus in these simple, abstract models a reasonable approximation to Cross and Parker's claim would be that energisers have larger cultural groups form around them than non-energisers and de-energisers do.

In the ACM the best definition for these cultural groups is that of the cultural region. To adopt this for other models will maintain compatibility with other researchers, especially Klemm et al (2003a; 2003b; 2003c; 2005). But the definition will need extending for the multi-row IRAM. We choose the following:

Cultural Region: Two agents are in the same region if and only if they are joined directly or indirectly by an unbroken chain of relations, such that in

each relation each agent of the pair has an exact feature-for-feature match in the other's IR Memory for each row of its own IR Memory.

When agents have $m = 1$ row of IR Memory this becomes the same definition as in the ACM. But unlike the ACM, at higher values of m it does not guarantee a successful interaction between two agents from the same region. For example, two agents with $m = 3$ rows may be such that one has {"AA"; "AA"; "BB"} in its IR Memory, while the other has {"AA"; "BB"; "BB"}. Both have at least one row of type "AA", and at least one of type "BB", but differ in the respective numbers of rows, and an interaction might begin with one presenting a trait "A" while the other presented "B". To guarantee interaction success would require that both had uniform IR Memories (for example, if both agents had "AA" in all three rows). But in this case part of the appeal of the IRAM - that agents can maintain more than one idea on a topic - would be lost. So we keep the above definition of cultural region and express our second claim in terms of it:

Claim 2: The expected size of the cultural region an Energiser belongs to is larger than that to which a non-energiser belongs. De-energisers belong to smaller regions.

Cross and Parker claim they also found a connection between energisers and performance.

"Not only were energisers better performers, but people who were closely connected to energisers were also better performers. In other words, energisers

raise the overall level of performance around them.” (Cross & Parker, 2004b, p.55)

The second sentence here could be misconstrued. Cross and Parker are not claiming that energisers cause people around them to be better performers. Rather, people who are already better performers are attracted towards energisers (as would also perhaps poor performers be) and succeed in occupying the places around them in networks of interactions. But it raises an intriguing question: are energisers beneficial for the organisation as a whole? If Cross and Parker are right in saying “energisers have a striking impact on what individuals and groups learn over time”, is that impact necessarily positive? In her Masters thesis Reinke raises the possibility of a negative impact without - presumably for reasons of time - being able to investigate it further (Reinke, 2005, p.50). If we can define a concept of performance, our simulation model should test whether the performance of the agent population as a whole is affected by the inclusion of an energiser or a de-energiser. How positive or negative effects are achieved may be complex, and too complicated to identify easily. For example, high performing individuals may be drawn towards the energisers when they would be better placed spread out in the social network of the organisation, or interacting more evenly with lesser performing non-energisers. In a cultural model individual performance is related to the cultural traits an agent holds, and good traits can spread through the population via the process of imitation. By drawing partners towards them, energisers may be hindering this flow. In addition, if claim 1 is correct, an energiser has a better chance of being imitated - suggesting one with poor traits has a better chance of those poor traits being taken up by others. So we base our third test on these questions:

Claim 3: Populations / Organisations / Social groups with energisers outperform those with non-energisers, which in turn outperform those with de-energisers.

We define “performance” as problem-solving performance, where the cultural traits presented in interaction rituals represent solutions to some problem and are more or less “fit” in solving it. The calculation of “fitness” used here is that of “Competence” defined above. We apply it to each agent’s cultural capital at the end of each simulation run (and in the case of the IR Memory models we apply it to each row of the agent’s IR Memory) and output an average for the population - a value between 0 and 1. Whereas for claims 1 and 2, comparisons are made within a population - between the energiser / de-energiser on the one hand and the other agents on the other hand - for claim 3 we compare whole populations - those with an energiser / de-energiser compared with those with only normal agents.

One final area of investigation does not test a specific claim by Cross and Parker but developed out of the work of this thesis - the relation between energy demand and supply, cultural groups and cultural boundaries. Cross and Parker are aware of a connection between energising and similarity:

“In addition to barriers created by organizational structure, authoritarian leadership, political organizational cultures, and even legal arrangements (in the case of alliances), we also find that energy networks themselves fragment at these boundaries ... People are often most energised by those who think like

they do and are de-energised by those who inhabit different cognitive worlds. Manufacturing employees, for instance, may be heavily de-energised by salespeople, and vice versa.” (Cross et al, 2003b)

Culture clashes de-energise. Cultural boundaries – such as those identified in the literature on communities of practice (see 1.3) – may represent also energy boundaries. When people are able to obtain their energy charge from a community of like-minded people, will they be receptive to ideas from outside the clique? It is conceivable that someone with energising characteristics may be able to introduce new ideas where others fail, including introducing common ground to communities of practice with no other basis for dialogue and cultural exchange. Cross and Parker do not make such a claim, and so we do not include it among the experiments conducted on each energy model in Chapter 8, Chapter 9 and Chapter 10. But it became apparent that energisers had a role to play in overcoming and bridging cultural boundaries. So as an extension we use our family of energy models to investigate this possibility in Chapter 11.

7.3 Experimental Design

We now describe the design of the experiments we ran for Chapter 8, Chapter 9 and Chapter 10. This includes the choice of experimental factors and other model parameter values, the initial state of the models, the run length, the results collection period, the number of simulation replications, and the processing of results. On the whole decisions were based on considerations of the time available for experiments, and also the manageability of large quantities of results data. As far as possible,

parameters were chosen to give the simplest models that seemed to promise results interesting in the light of the objectives. Lacking the benefit of foresight these choices will not always yield interesting results, and some revision was needed. The experimental design reported here represents the result of an iterative process of development.

7.3.1 Population size, network structure and energising parameter values

As described above, we concentrated on a small population, of size $N=20$ agents. With such a small population it is reasonable to assume every pair of agents is physically capable of interacting, so we do not need to consider alternative network architectures. But from an early stage we found 20 sufficiently large to produce results similar to those reported for versions of the Axelrod Cultural Model. Within the population we have 19 agents of normal energising capability - represented by an energising parameter value of 1. The parameter value for the remaining agent is an experimental factor and is taken from the set $\{1/6, 1/3, 2/3, 1, 3/2, 3, 6\}$, with values below 1 representing energising characteristics, and values above 1 de-energising characteristics.

7.3.2 Payoff functions

There are three sources of payoff from interactions, representing a sense of autonomy, belongingness and competence and denoted in the text by A, B and C. We have the

option of testing each source on its own or in combination with one of the others. Belongingness is the most interesting, given the importance of cultural similarity in the ACM and in the literature. Competence is needed to test claim 3, but Autonomy produced the least interesting results with the first model and so in the later models we focussed on Belongingness and Competence. For simplicity, where payoff sources were combined, the one agent with energising / de-energising characteristics was given them for just one of the sources. For any additional source the agent took the normal parameter value of 1. So, for example, an experiment might include 19 agents with Belongingness and Competence payoffs raised to the normal power, 1, and one special agent with Belongingness raised to a power set by the energising parameter - the experimental factor - and Competence raised to the normal power 1. In the results chapters we represent such an experimental scenario as “B=E, C=1”.

7.3.3 Decay rates and half lives

Energy decay represents one of the key respects in which the energy models differ from the ACM. Its rate determines current energy levels and hence the updating of cultural capital, and expected gain and hence the various sampling processes when these are stratified. Without any representation of specific temporal processes, we have no preconceptions about what constitutes a realistic value for a decay rate and so this becomes an experimental factor. We tested five values, {0.8, 0.98, 0.998, 0.9998, 0.99998}. “0.8” means every iteration each energy level is reduced to 80% of its value in the previous iteration. Hence the smallest value, 0.8, gives the fastest decay rate. Where higher (slower) values than 0.99998 were tested, they produced little or no change in the model during a simulation run, and thus the results from using them

were excluded. For displaying and interpreting results we converted decay rates into energy half lives, where:

$$\text{Half Life} = \log(0.5) / \log(\text{Decay Rate})$$

Thus our five decay rates become half lives of {3.1, 34.3, 346.2, 3465.4, 34657} to one decimal place. It will be noted that the up-scaling is not smooth - our decay rate values were chosen for ease of entry. But each half life is approximately ten times that of the previous. If we were to obtain idealised half life values by dividing 34657 by 10 successively, plotting the logarithms of these ideal values against the logarithms of our actual half life values and fitting a linear trend line we find the regression coefficient $R^2 = 0.9999$. This is close enough for our purposes.

Half life tells us how many iterations we would have to wait for an energy level of 1 to fall sufficiently for a payoff of 0.5 to beat it. There is nothing in the theory of interaction rituals that tells us whether we can vary or choose between decay rates in real life. What we can choose, however, is the rate at which we interact with people - for example, do we meet hourly, daily, weekly etc. An alternative interpretation of this experimental factor, then, is that it represents different periods of time between interaction attempts, given some constant decay rate. A parameter value of 0.8 means long inter-event times - during which energy levels have decayed a lot - compared to 0.99998, which represents very short inter-event times, and very frequently interaction attempts.

7.3.4 Features, traits and memory sizes

The number of traits, q , and the number of features, F , were demonstrated by Castellano et al (2000) to jointly determine the level of cultural diversity emerging in the ACM. Low values of (q / F) produced a culturally homogeneous, one-region population. High (q / F) produced a culturally heterogeneous, many-region population. Not having any preconceptions of a realistic value for q , nor for cultural diversity, we need to make q an experimental factor. We therefore test seven values: $\{2, 4, 8, 16, 32, 64, 128\}$.

Early experimentation with versions of the ACM suggested to us that both processing time and the expected number of iterations until a system converged varied linearly with the number of features. Small values of F , therefore, take less time to run and need few simulation iterations. $F=2$ is the minimum value, since one feature match is required for a successful interaction, and one feature mismatch is required for which imitation can occur. Higher values of F would require higher values of q to obtain the same values of (q / F) , with some additional computational cost in our models. Castellano et al (2000) note the behaviour when $F=2$ is not typical of $F>2$, but since our interest is primarily in energy models we chose the simplest value. Preliminary experiments with $F=3$ failed to reveal any differences relevant to our objectives, and so we focus on $F=2$.

For the models with IR Memory, the memory size or number of rows, m , also determines processing time and convergence behaviour. For the IRAM, where memories include past interaction partners, too few rows will mean agents have to

sample from too limited a set of potential partners in future. There will also be too little memory for recording multiple associations between particular partners and particular cultural traits. On the other hand increasing, memory size proved computationally expensive. In 10.4 we opt for testing values from 1 to 8 in the hope that trends might emerge.

7.3.5 Simulation initialisation, iterations and replications

At the start of a simulation run agents must be assigned cultural traits and the information needed to calculate expected gain - energy levels at last charge up and the time of the last charging. In line with the ACM we set cultural features to randomly selected traits sampled from the q traits available with uniformly distributed probabilities. For the IRAM, IR Memory also contains information on participants in the remembered IR events, an initiator and a recipient. This information is then sampled from in selecting future participants. To ensure every agent has its best chance of being sampled to initiate future IR events, we set every row of each agent's IR Memory to record that agent as having been Initiator. Each record of a recipient is set by sampling from all other agents in the population, with uniformly distributed probabilities. The "times of occurrence" of the IR memories are set to -1, where time units are represented by simulation iterations, and one interaction attempt is made each iteration. Expected gain calculations are based on the difference between current time and time of occurrence, so by using -1 all agent memories have positive expected gain at simulation start (time = 0). Energy levels at time of occurrence are set to the fitness values of the cultural traits, using the same function as that to be used in calculating the Competence component of IR payoffs. If statistics on these initial

energy levels are collected and compared with the mean fitness values of IR Memory contents at the end of the simulation this will allow calculation of fitness improvement.

These initial settings of IR Memories are not intended to be realistic, nor are they expected to reappear during the simulation run. We choose them in part for want of better settings, and study the evolution of the system during simulation runs to try to collect output data over a period when the system is in some sort of steady state. In the ACM this period was easy to determine. The ACM converges to a static system state, at which no pairs of agents remain such that they have sufficient similarity to be able to interact successfully and yet one can still imitate the other. If a program identifies that this static state has been reached, it can halt the simulation run and calculate the final statistics - such as number of cultural regions and the size of largest region. In our energy models, things are less straightforward. It is conceivable for two agents to have sufficient similarity to interact, and some difference to allow imitation, and yet repeatedly fail to imitate each other if the current charge on their culture remains higher than the payoff produced by the current IR event. Charge decays over time, but before they can interact again they have the chance to interact with any more similar agents. Agents who match in every feature can generate Belongingness scores of 1, which will then take a half life to decay sufficiently before a score of 0.5 can beat them. Interaction pairings are selected in a stochastic process, so in theory two agents could have time to decay sufficiently for the one to be able to imitate the other, but at longer half lives this is unlikely. So boundaries between cultural groups in the energy models may be highly stable without being based on pairs of completely dissimilar agents. In view of this, we made preliminary studies of simulation runs with

each model. In all cases it was possible to identify different phases in the system evolution, with system-level statistics such as number of regions settling down to make only minor changes compared with the earlier, post-initialisation phase. We could try to identify “stochastically stable” system states (i.e. when variance settles within specified limits) using some calculation, but we settled for an informal, visual identification of this. Different energy models required different run lengths, and the number of simulation iterations is given in each results chapter. Output statistics are either based on the whole simulation run (Frequency of being imitated), or the system state at simulation end (Size of agent’s region, Fitness value of agent’s culture).

For each combination of parameter values in each experiment we ran multiple replications. This is expected to produce more reliable findings, with less chance of identifying patterns where there should be none, and less chance of failing to identify patterns that should be present in the theoretical model. But more replications mean more computer time to produce them. In addition, it is noticeable that some of the most interesting agent-based simulation models in the literature were first reported on using experiments based on relatively few replications. Axelrod’s paper mentions 10 (Axelrod, 1997a, p.160) - perhaps not many compared to the standards employed to get papers accepted by journals today, but sufficient to get other researchers (such as Klemm et al) interested in the model and its possibilities. Most of our experiments employed 20 replications. In a few model scenarios - mainly those with payoffs based purely on Belongingness - more were used - partly due to our particular interest in this payoff function, and partly due to the practical availability of computer resources to run them on. Statistics based on more replications will have narrower confidence intervals, and if, say, the mean value for energisers beats that for non-energising

agents, then there is more chance that a t-test will reject the null hypothesis that they are the same. We found, however, that the few scenarios where we ran more replications did not produce dramatic improvements in results. For most combinations of parameter values it was fairly clear-cut whether a claim held or not. Where a claim held for a range of values, running more replications had the potential to extend this range by only one place, and did not always do even this. Hence, we conclude that 20 replications offer a good compromise between reliability of conclusions and use of computing resources and time.

Much simulation literature discusses the use of “variance reduction methods” to reduce the number of simulation replications required for reliable results (Law & Kelton, 2000). It is uncertain as to whether these methods have any benefits with agent-based simulation - this is an area for research. However, the many interdependencies between agents, and the changing context or value of a particular agent action, lead us to suspect it would be unprofitable to try any variance reduction methods on our models.

7.4 Technical Issues

7.4.1 Coding a simulation model

The simulation models are produced by a single program written by the author in VBA within Microsoft Excel 2003. This environment was chosen for a number of reasons. This author has many years of experience in developing models of complex

or network systems, including agent-based models, and has good knowledge of techniques to use and potential problems (e.g. flaws in Excel/VBA), and some components that could be recycled from other, tried-and-tested programs. Although software packages do exist to aid the development of agent-based models, they do not yet reach the ease of use found in a popular commercial discrete-event simulation package (e.g. Simul8 (SIMUL8 Corporation, 2009)), and most require knowledge of JAVA programming to progress beyond the simplest models. When one of the biggest challenges in a simulation project lies in the design of the simulation model itself - not least when it is believed no existing models can serve as a guide to what is needed - then familiarity with a rapid application development environment such as Excel/VBA is essential. Not only can a model be developed quickly, but its output can be analysed and charted within Excel, and its code modified and rerun easily.

7.4.2 Random number generation

Earlier experience with versions of the ACM revealed a potential problem with random number generation. The models are very number-hungry - each iteration needs several numbers, there may be 200 000 iterations in a run, and an experiment might easily involve 40 000 runs. The pseudo-random number generator in VBA is not well-regarded (L'Ecuyer, 2001), and so we employ the Mersenne Twister pseudo-random number generator of Matsumoto and Nishimura (1998). A version of this written in C was downloaded (Matsumoto, n.d.), and rewritten by this author to permit multiple, parallel streams of random numbers (not needed in the end, but potentially useful in variance reduction methods). Once compiled to form a .DLL file, the functions of the generator can be called from VBA. Versions written in VBA are also

available for download, but the C version approached the speed of the VBA Rnd function. Its creators claim the Mersenne Twister a period of $2^{19937-1}$ - there will be no danger of cycles in any streams of random numbers during our use of it.

7.4.3 Data processing

The author's VBA program output results of each simulation replication as additions to three .csv format text files - one for the simulation's parameters, one for the evolution and one for final agent attributes. These were imported into an Access database where mean values were calculated for the energiser / de-energiser and for the other agents. These data were then queried via MS Query by Excel pivot tables in three workbooks - one workbook for each claim being tested. Another workbook used macros to perform t tests on the comparisons in these pivot tables and display the results. These results appear in Chapter 8, Chapter 9 and Chapter 10. Thus the sequence of data forms is: VBA; csv file; Access; MS Query; Excel pivot table; VBA. Such a complex data flow - involving user-intervention at each switch of software packages - proved time-consuming, especially during development, but no problems with accuracy of data transfer were identified.

7.5 Seeing and Believing in an Agent-Based Model

How can we build confidence in agent-based models? We have discussed the design and construction of a family of simulation models, and the experiments we will report on in the following chapters. We have sought to build confidence in the model design

by relating it to other models and techniques – especially the Axelrod Cultural Model – and we will seek to build confidence in the programmatic implementation of the design by using our program to reproduce in section 8.2 the behaviour of the Axelrod model. As detailed in this chapter we use multiple replications to build confidence in the reliability of statistical outputs. As will be seen in the next chapters, by testing a range of parameter values for each factor we can use the values at adjacent points on charts to indicate a well-behaved model. On a 3D response chart a smooth landscape promotes confidence; a rugged one suggests high variance among the replications; unexpected jumps along a dimension suggest artifacts in the model, or at least a surprising phenomenon worth investigating further.

We are limited, however, by the fact that no models have gone beyond the ACM in the direction of our energy models, and that we may have few if any preconceptions of how energy models will behave. As we construct and experiment with the models, then, we have to repeatedly ask whether the model’s behaviour makes sense: makes sense in the light of the model design (roughly what is referred to as “model verification”) and sense in the light of theory and other models and empirical studies (“model validation”) – especially Cross and Parker’s work. In this section we detail some of the visual displays that serve to aid us in posing and answering these questions.

For an at-a-glance survey of the agent population, the grid display in *Figure 27* shows all agents and their cultural traits, and colours can be used to show agents in the same cultural region or cultural zone. Experience with audiences suggested that this type of display was most effective in communicating the concepts behind the ACM-related

part of the model. It works best in this regard when 2-D grid network architecture is employed. With a complete network, agent location on the screen has no meaning. It also proves less useful as the number of cultural features to be displayed increases, or if the model uses multi-row IR Memory.

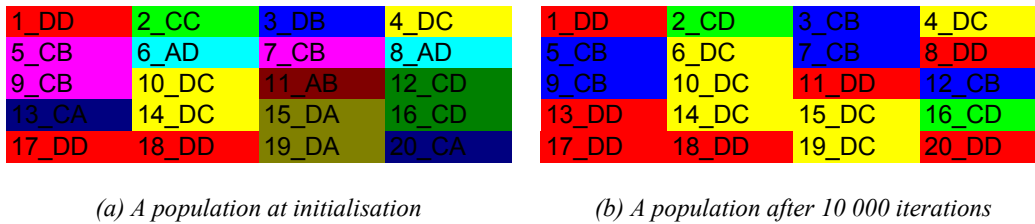
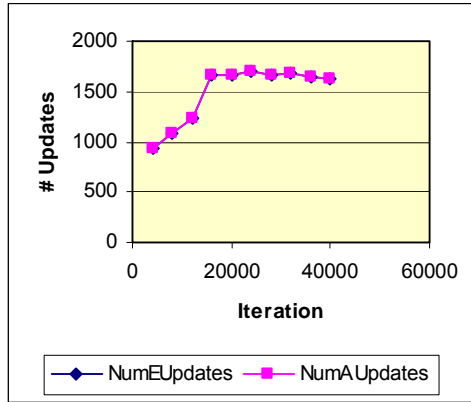

Figure 27 Two grid displays from an agent-energy model

Two grid displays from an agent-energy model, both with $N=20$ agents, $F=2$ features and $q=4$ traits (represented here by the letters A, B, C and D). Agents are displayed with their identity number and the traits for their two features. Colours represent distinct combinations of cultural traits. Note that for this relatively low value of q several of the agents at the simulation start (a) have the same cultural traits - e.g. agents 1, 17 and 18 have “DD”. On the right (b) we have a population with the same parameters (plus a decay rate = 0.998 and a payoff function based on Belongingness) after 10 000 iterations. The system has stabilised almost completely, with agents now grouped into four cultural regions. Notice that agents with “DC” have a trait in common with those with “DD”, and so successful interactions are still feasible between these two groups. Imitation, however, will require that a would-be imitator has a current energy level ≤ 0.5 . Since agents can recharge to 1 by interaction with members of their own cultural region, another imitation event may be a long time in coming.

At simulation start and 10 points in time thereafter aggregate or system-level statistics are output. Charts based on these can give an impression of the evolution of the simulation, including the point at which system behaviour becomes relatively stable. Figure 28 shows the level of activity over time (energy charge updates and imitations), cultural diversity (sizes of largest cultural region and zone; numbers of

regions and zones) and the mean level of expected gain given the current contents of IR Memories. This represents the model on a summary, macro level.



(a) # Energy charge updates for Ego and Alter

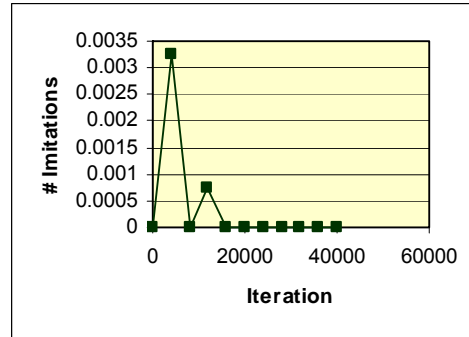

(b) # Imitation events

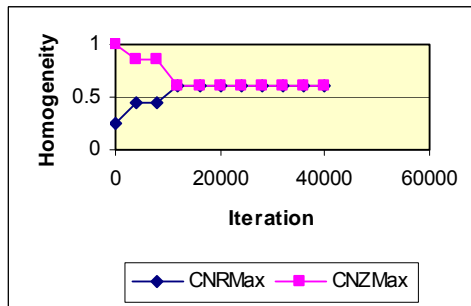

(c) Homogeneity measures: size of largest region and zone

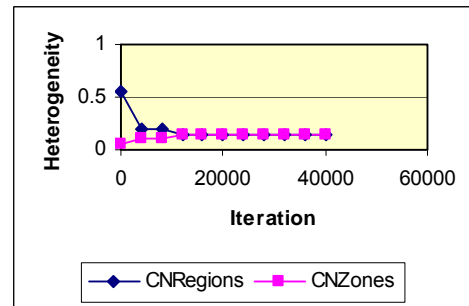

(d) Heterogeneity measures: # regions and # zones

Figure 28 Output showing simulation evolution

Output showing simulation evolution in a model similar to that in Figure 27 but this time with 40000 iterations.

For a micro-level view of each individual interaction there is the event list in Figure 29(a). Each iteration two agents are selected for interaction, there is some outcome to the interaction and cultural capital is presented, and if successful the interaction will produce a score based on the proportion of matching features – which then determines agents' sense of Belongingness. For example, a score of 0.5 shows that only the first

feature comparison succeeded, while 1 denotes that both feature comparisons worked. This information can then be used to show relations between the interaction ritual events – such as commonality of participants and commonality of the cultural traits focussed on. *Figure 29(b)* goes some way to making visible the “interaction ritual chains” mentioned in Collins’s theory (Collins, 2004, p.152, figure 4.3). These displays are useful when questions are asked about particular participants or particular cultural combinations, but obviously in a simulation run of tens of thousands of iterations the user needs to know which time period to focus attention on.

Iteration	Ego	Alter	Round	Outcome	Score	CC1	CC2
1	18	9	1	3	0	4	3
2	5	9	1	3	0.5	2	1
3	11	5	1	15	1	2	1
4	3	12	1	3	0	1	1
5	9	6	1	3	0	1	1
6	20	12	1	3	0	2	2
7	10	6	1	3	0	2	4
8	8	3	1	3	0	3	2
9	15	8	1	3	0	2	2
10	6	13	1	3	0	4	4
11	10	13	1	3	0.5	2	3
12	8	19	1	3	0	3	2
13	13	15	1	3	0.5	2	2
14	19	12	1	3	0.5	4	3
15	6	8	1	3	0	4	4
16	18	1	1	3	0	4	3
17	4	6	1	3	0	2	3
18	7	6	1	3	0	3	2
19	5	4	1	3	0	2	1
20	1	12	1	3	0	3	1
21	4	19	1	3	0	2	3
22	18	4	1	3	0.5	2	3
23	12	1	1	3	0	4	3
24	5	20	1	3	0	2	1
25	5	4	1	3	0.5	2	1
26	10	17	1	3	0	2	4
27	10	20	1	3	0.5	2	4
28	8	14	1	3	0	3	2
29	14	16	1	3	0	4	1
30	17	4	1	3	0	4	3
31	2	15	1	3	0.5	2	2
32	4	13	1	15	1	2	3
33	12	14	1	3	0.5	4	3
34	4	14	1	3	0	2	3
35	12	9	1	3	0	4	3
36	12	17	1	15	1	4	3
37	7	11	1	3	0	3	2
38	6	18	1	3	0	4	4
39	19	17	1	3	0	4	1
40	16	1	1	3	0.5	3	3
41	20	2	1	3	0	2	2
42	12	17	1	15	1	4	3
43	17	20	1	3	0	4	3
44	14	15	1	3	0	4	1
45	5	2	1	3	0	2	1
46	5	15	1	3	0.5	2	2
47	15	3	1	3	0	2	2
48	13	8	1	3	0	2	3
49	16	4	1	3	0.5	2	3
50	5	11	1	15	1	2	1
51	9	1	1	3	0.5	3	1
52	20	19	1	3	0	2	2

	1_1	1_2	1_3	1_4	2_1
26					
27		10_20			
28					
29					
30					
31		2_15			
32		4_13			
33				12_14	
34					
35					
36					12_17
37					
38					
39					
40					
41				16_1	
42					12_17
43					
44					
45					
46		5_15			
47					
48					
49		16_4			
50		5_11			
51			9_1		
52					

(a) Details of interaction ritual events listed

(b) Interaction ritual chains

Figure 29 The simulation’s iterations displayed individually

(a) shows the first 52 interactions during a simulation run, including participants, culture focussed on and outcome. (b) uses the information for events that generated energy payoffs (Belongingness), shown in columns for each combination of cultural traits. Interactions involving a particular agent (such as agent 1) can be highlighted. This display makes Collins’s “Interaction Ritual Chains” visible.

Another output to study cultural evolution in the model is shown in Figure 30. By using cultural features as the dimensions to a “culture space”, we can display frequency distributions for the combinations of cultural traits in an agent population. Patterns in the locations of agents in culture space can indicate whether a population has converged on a stable set of regions (compare (a) with (b)). They can also show the impact of giving agents a payoff component based on Competence (c), or fitness, and a source of cultural innovation akin to a mutation process in heuristic search (d).

Freq2FStart	1	2	3	4	5	6	7	8
1	0	0	0	0	1	0	1	0
2	0	0	2	0	1	0	0	1
3	0	0	1	0	0	1	0	1
4	1	0	1	1	1	0	1	1
5	0	0	0	0	0	0	0	0
6	1	1	0	0	0	0	0	0
7	0	0	0	1	0	0	1	0
8	0	0	0	0	1	0	0	0

(a) At simulation start

Freq2FStart	1	2	3	4	5	6	7	8
1	0	0	0	0	0	0	0	0
2	0	0	0	1	0	0	0	0
3	0	0	0	0	0	0	0	0
4	0	0	0	0	0	0	0	3
5	0	7	0	0	0	0	0	0
6	0	0	4	0	0	0	0	0
7	0	0	0	0	0	4	0	0
8	0	0	0	0	0	0	1	0

(b) At simulation end

Freq2FStart	1	2	3	4	5	6	7	8
1	7	0	0	0	0	0	0	0
2	0	9	0	0	0	0	0	0
3	0	0	0	0	0	0	0	1
4	0	0	0	0	0	0	0	0
5	0	0	0	0	3	0	0	0
6	0	0	0	0	0	0	0	0
7	0	0	0	0	0	0	0	0
8	0	0	0	0	0	0	0	0

(c) After using a fitness function that decreases linearly with trait number

Freq2FStart	1	2	3	4	5	6	7	8
1	8	0	5	2	0	0	0	0
2	5	0	0	0	0	0	0	0
3	0	0	0	0	0	0	0	0
4	0	0	0	0	0	0	0	0
5	0	0	0	0	0	0	0	0
6	0	0	0	0	0	0	0	0
7	0	0	0	0	0	0	0	0
8	0	0	0	0	0	0	0	0

(d) After using a fitness function and a source of innovation

Figure 30 Depictions of “culture space”

Agents have $F=2$ features taking $q=8$ traits, represented by row and column numbers 1-8. At each point in “culture space” the number of agents with that combination of cultural traits is indicated. (a) shows a system at simulation start, when agents are fairly evenly spread. (b) shows a similar system at simulation end, when agents have formed cultural regions and no pair of agents share one and only one trait (represented by the fact that no row or column has more than one point with agents in). (c) shows that the use of a fitness function that scores traits in descending order will cause regionalisation to tend towards high-scoring culture – in this case (1,1) and (2,2). (d) shows a similar model with a source of cultural innovation added. Deviation from the high-scoring region occurs, but in this case has not occurred in more than one feature. Hence deviants are stretched along either row 1 or column 1.

It is sometimes said of simulation models that they lack intrinsic validity since they represent black boxes in their workings (Lehtinen & Kuorikoski, 2007). While no one would want to use interaction-level, agent-level or culture-level displays to follow a simulation run in every detail – that would be impractical and miss the point of seeking help from computer simulation – these displays go some way to providing a look inside the “black box”. With the help of these displays and repeated questioning

of whether the models “made sense”, our models have been debugged, interpreted and in parts redesigned in a reiterative process lasting many months.

7.6 Summary

We have described the setup of experiments to test claims about energisers derived from the empirical work by Cross and Parker. We then mentioned some technical issues that arose during the experimentation. Finally, some explanation was given as to how we built confidence in our models, especially using visual displays to see inside the “black box” of the simulation program.

We now turn to the results obtained for each model.

Chapter 8 Energy applied to agents

8.1 Introduction

In this chapter we test the three claims using the first of our energy models – in which each agent has an energy level that is charged up during interactions and decays over time. As discussed in 7.3 our experimental factors include:

- the number of traits, q ;
- the decay rate, represented here in terms of energy “half life”;
- the method of calculating payoffs, including the way in which energisers affect the energy payoffs of others, and;
- the strength of energisers’ effects on payoffs.

We discuss each claim in a separate section, illustrated with the most informative experimental results. A fuller set of charts for the experiments is given in Appendix B.

8.2 Relating the energy model to the ACM

Castellano et al (2000) demonstrated cultural diversity metrics in the Axelrod Cultural Model (ACM) followed S-curve behaviour with respect to the number of cultural traits (q) divided by the number of features (F). We can try to reproduce this behaviour in our own version of the ACM and in our energy models.

We start with energy payoffs based on Belongingness – based on the proportion of cultural features interacting agents have in common. This model is closest to the ACM. Indeed, if we plot values of Size of largest region for a relatively short energy half life (i.e. a fast decay rate) against the corresponding values from the ACM we come very close to $y=x$ (*Figure 31*). In both cases, the 95% confidence interval for the regression slope coefficient includes 1.

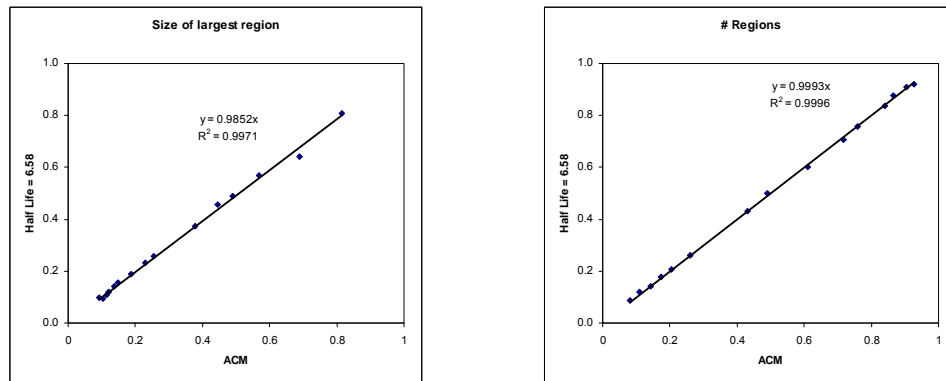

(a) Size of largest region

(b) Number of regions

Figure 31 Comparing the agent-energy model to the Axelrod Cultural Model

Comparing the agent-energy model to the Axelrod Cultural Model across a range of values of (q / F) . Results from an energy model with relatively short half life (6.58, produced by a decay parameter of 0.9) plotted against those from an Axelrod Cultural Model.

This resemblance to the ACM disappears at slower decay rates (*Figure 32*).

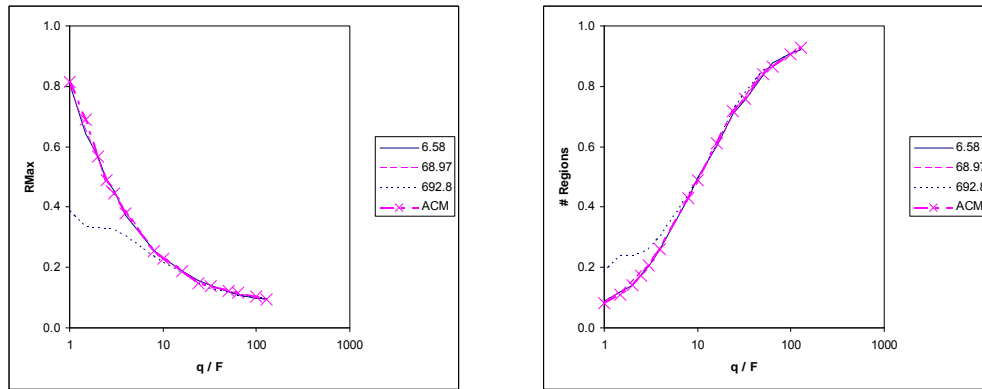

(a) Size of largest region versus q / F

(b) Number of regions

Figure 32 Cultural diversity measures plotted against q / F

Cultural diversity measures plotted against q / F for the Axelrod Cultural Model and the agent-energy model with three half lives. The two energy models with faster decay rates (half lives 6.58 and 68.97) are near identical to the ACM.

There is no surprise here. In the ACM, imitation occurs when two agents have matched traits for their first chosen feature, but have at least one feature where they do not match. In the agent-energy model an extra condition is inserted. A would-be imitator must have sufficient energy charge from the interaction to replace their current energy level. Given just two features and assuming no energising effects, the possible values for Belongingness-based energy charge are: 0 (no features matched, so interaction failed); 0.5 (one feature matched), and; 1 (all features matched, so no scope for imitation). The only case in which imitation can occur yields 0.5. If the would-be imitator gained an energy charge of 0.5 or less during their last interaction, a new charge of 0.5 is sufficient for imitation. However, if the previous charge was more than 0.5, imitation will only occur if that energy level has now decayed to below 0.5. With unbiased sampling of participants from a population of N agents, the chance of being sampled for each agent is given as the chance that it is picked as Ego plus the chance that it is picked as Alter:

$$\frac{1}{N} + \left(\frac{N-1}{N} \times \frac{1}{N-1} \right) = \frac{2}{N}.$$

The two participants have equal chance of being the imitator in an interaction, so if we could ignore cultural considerations, every agent would expect to be imitator on average every N iterations. The real frequency depends, of course, on agents' cultural capital in the current state of the system, and at the start of the simulation run this is determined by values of q and F . But whatever this real frequency is, the expected inter-event time for an agent being imitator will be longer than N iterations. A half life lower than N promises us that a fresh energy level of 1 is likely to have decayed below 0.5 by the time of the next interaction. Indeed, a half life of less than 1 iteration would guarantee that energy levels produced no barrier to imitation, and thus produce a model equivalent to the ACM. The ACM, then, appears to be a special case of the energy model – one in effect with indefinitely fast energy decay.

8.3 Claim 1: The take up of ideas

Our first claim derived in 7.2 from Cross and Parker's work was concerned with the take up of energisers' and de-energisers' ideas, measured here by the frequency of imitation events.

Claim 1: Energisers are imitated more frequently than non-energisers, and de-energisers are imitated less frequently.

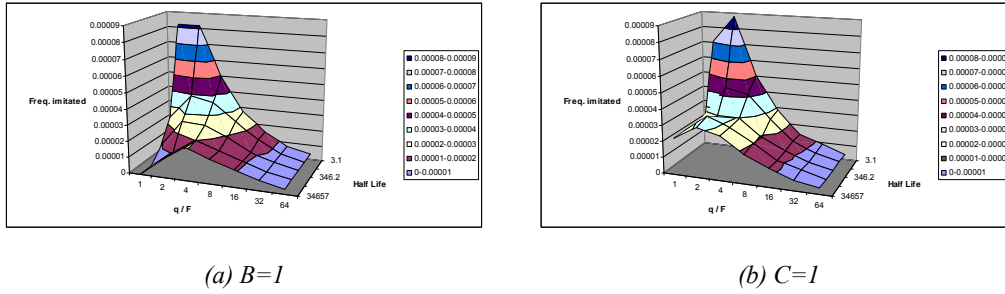

Figure 33 Frequency of being imitated, given by q / F and half life, for the agent-energy model

With (a) energy based on Belongingness (i.e. on number of trait matches); (b) energy based on Competence (i.e. fitness).

Looking at the charts for Frequency of being imitated (B.2, various subsections, charts (a) (i) in the appendices; also *Figure 33*) we see values vary widely with number of traits, q , (number of Features, F , being held constant at 2) and energy half life, including a peak around the point of our shortest half life and a low q (2 or 4, giving q / F of 1 or 2). Imitation requires a successful interaction, which in turn requires that the participants match traits for the first feature compared. As (q / F) increases, the chances of this occurring decline. Imitation also requires that the agent's energy level has decayed sufficiently for the new interaction's energy charge to beat it. The chances of this happening between interactions decline as the decay rate decreases - i.e. as the half life increases.

We also notice much similarity for these q -versus-half-life landscapes between our various payoff functions. Some differences however are worth pointing out, though. At $(q/F) = 1$, payoffs involving Belongingness result in a further downturn for the highest half-life values. Payoffs based purely on Autonomy or Competence do not show such a large downturn. With two features, imitation can only come from one-feature matches, and these generate Belongingness of 0.5 (without energising effects).

For longer half lives, energy levels of 1 do not decay sufficiently for a charge of 0.5 to beat them. So no imitation events can be recorded at these half lives. However, a one-feature match can involve an agent dominating for two features (giving Autonomy=1) or cultural traits of the top fitness (giving Competence=1). So if energy payoffs include either of these two components there is more chance of an imitation-enabling charge.

Turning now to the question of whether an energiser has greater chance of being imitated, we see more differentiation between the payoff functions (B.2 (a) (ii); also *Figure 34*). Positive values in these charts imply that the energiser is imitated more frequently than the other agents - in line with claim 1. But how much more frequently it is imitated varies with q and half life. Since these figures are simple differences we might expect the biggest differences to occur where before we saw the peaks in frequency of being imitated (*Figure 33*). But the peaks in *Figure 34* occur for different values of q and half life. Exactly where is one point of differentiation between the payoff functions. Functions involving Autonomy produce a peak for the shortest half life (c); those based on Competence produce a peak at our longest half life (b); Belongingness produces one at an in-between half life (a). In addition, the peak is not always located at the smallest value of q / F .

The charts for populations with a de-energiser show more complex (“rugged”) landscapes, including multiple peaks (B.2 (a) (iii); also *Figure 35*). If there is any commonality between them, it lies in the main peak occurring at shortest half life. It may be harder to establish claims for de-energisers. But on the face of it, de-

energisers are imitated less often than the non-de-energisers for a wide range of values of q and half life.

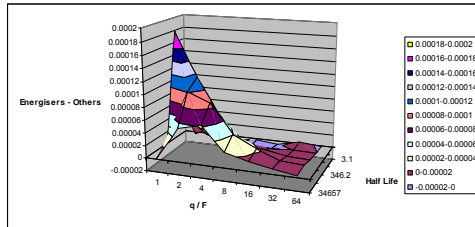

(a) $B=E$

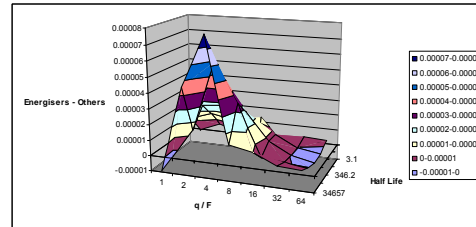

(b) $C=E$

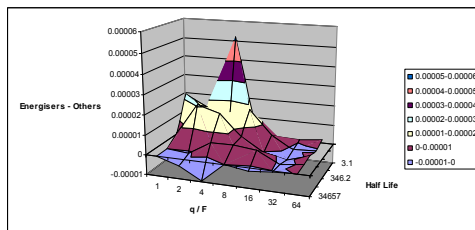

(c) $A=E \text{ \& } B=1$

Figure 34 Difference in frequency of being imitated between Energiser ($E=1/6$) and the mean of the non-energiser agents

Given by q / F and half life, for the agent-energy model: (a) energy based on Belongingness (i.e. on number of trait matches); (b) energy based on Competence (i.e. fitness); (c) energy based on Autonomy and Belongingness, with energising occurring in Autonomy.

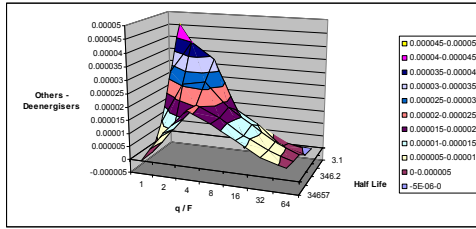

(a) $B=E$

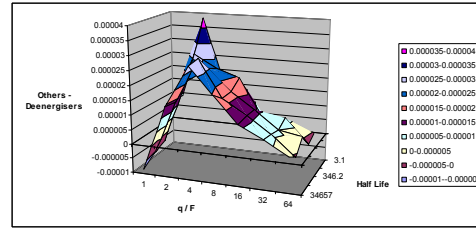

(b) $C=E$

Figure 35 Difference in frequency of being imitated between the mean of the non-de-energiser agents and a De-energiser ($E=6$)

Given by q / F and half life, for the agent-energy model: (a) energy based on Belongingness (i.e. on number of trait matches); (b) energy based on Competence (i.e. fitness).

The positive figures in the charts in *Figure 34* and *Figure 35* tell us of results in line with claim 1: differences between energisers and non-energisers, and between non-de-energisers and de-energisers. But they do not tell us how important those differences are - for example, how large these differences are relative to the expected frequency of being imitated for normal agents. *Figure 33* showed that this latter varied. In addition, the charts do not tell us whether the evidence supporting the hypothesis that there are differences is statistically significant. Given standard deviations from our samples of simulation replications, we can calculate confidence intervals for each (q , half life) point in factor space, and perform t-tests.

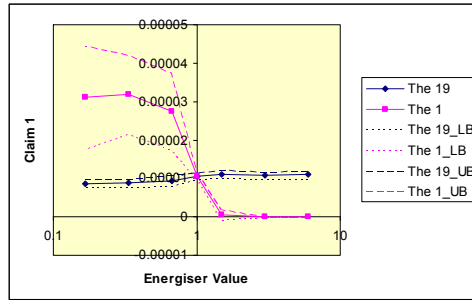

Figure 36 Comparing the 1 energiser/de-energiser with the other 19 agents, for Frequency of being imitated

Values on the x-axis below 1 (left of the axis) produce an energiser; those above 1 (right) produce a de-energiser. Here we use Belongingness only for energy payoffs ($B=E$), with $q / F = 16$, half life = 3465. 97.5% confidence intervals are shown around their respective means, giving us at least 95% confidence where the two sets of intervals do not overlap.

Figure 36 illustrates how to think about this. We see for Frequency of being imitated mean results (from 40 replications) for the two groups of agents: the 1 special agent - a energiser/de-energiser, and; the other 19 agents. The results for the special agent form an s-curve across the energising parameter – in line with claim 1. Energisers (energising parameter < 1) have higher take-up of their ideas. De-energisers have lower (energising parameter > 1). At each point on the x-axis, by calculating 97.5% confidence intervals for each mean we can compare the energiser / de-energiser agent to the others with 95% confidence. Clearly, for Frequency of being imitated energisers beat the others for all tested energising values of the parameter, and de-energisers are beaten by the others for all de-energising values tested.

Systematic searches were performed for similar behaviour from models with the various payoffs, for all values of q / F in $\{1, 2, 4, 8, 16, 32, 64\}$ and half lives in $\{3.1, 34.3, 346.2, 3465.4, 34657, 346573.2\}$. t tests were performed at each of the six

energising or de-energising parameter values, and the results summarised with a score (Table 3).

Table 3 Tests scoring for Claims 1 and 2

Score	Explanation
3	1) For x in $\{1/6, 1/3\}$ confidence interval (CI) for mean Energiser above that for mean of Other agents, &; 2) for $x = 1/1.5$ CI for Energiser not below that for Others, &; 3) for x in $\{6, 3\}$ confidence interval (CI) for mean De-energiser below that for mean of Other agents, &; 4) for $x = 1.5$ CI for De-energiser not above that for Others.
2	Conditions (1),(2) from above hold, but not (3), (4)
1	Conditions (3),(4) from above hold, but not (1), (2)
0	None of the conditions are met.

This score depends then on six one-sided t tests, each at a certain level of significance, alpha. If we treat these six tests as independent events, the confidence for the score becomes $(1-\alpha)^6$. To get a chance of 95% of making at least one type I error – of rejecting a true null hypothesis – during our six tests, we set alpha to:

$$1 - (0.95^{(1/6)}) = 0.00851 \text{ (3 s.f.)}$$

The results of two such searches appear in *Figure 37*. The case viewed in *Figure 36* ($q / F = 16$ and half life = 3465.4) can be identified as scoring 3 in *Figure 37(a)*. If the payoff function is based on Competence and not Belongingness (b), the same point

scores 0. Comparing *Figure 37* also with (a) and (b) in *Figure 34* and *Figure 35*, one notes that the earlier figures would be a poor guide to the t-test-derived scores.

Other search results are included in appendix section B.3. It will be noted that successful parameter ranges tend to be:

- moderate to long half life, and;
- low to moderate q / F .

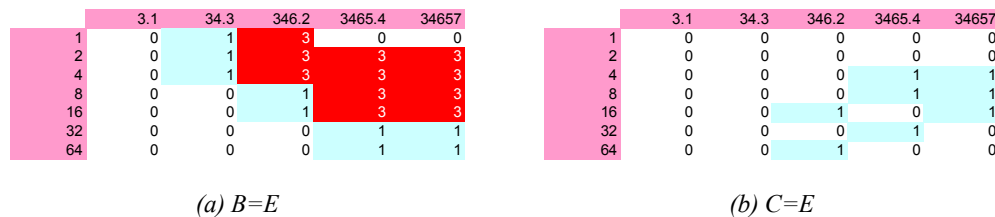

Figure 37 Results from systematic searches for Frequency of being imitated

Results from systematic searches for Frequency of being imitated for cases in which energisers beat the others (scores 2), de-energisers are beaten (scores 1) or both (scores 3). The same payoff functions are used as in *Figure 33* and *Figure 35*.

It will also be noted that the models in which energisers/de-energisers altered Autonomy (A=E; A=E, B=1) produced almost no cases of non-zero score. Only the models in which they altered Belongingness or Competence produced cases in which claim 1 was validated.

The t-test analysis was repeated for different levels of confidence and for a weaker summary rule (involving the transfer of $x=1/3$ from condition (1) in Table 3 to condition (2), and $x=3$ from (3) to (4)). As expected a lower confidence level and the

weaker conditions meant higher scores and wider regions of positive scores in the searches than those in *Figure 37*. But there were no new regions of positive scores unconnected to those already seen. So the above description (moderate to long half life, low to moderate q/F) remains the best guide to finding parameter values for models that satisfy claim 1. However, although the study of model (B=E) was based on 40 simulation replications, all the others involved just 20. Our process for reporting on the systematic searches does not give indication beyond the scores 0-3 of how close a particular model-parameter combination was to scoring better. It may be that more replications would find more cases that satisfied claim 1 - though, of course, they would require more processing time to generate.

8.4 Claim 2: The size of an agent's region

Our second claim derived from Cross and Parker is in terms of “Cultural Regions”, where these were defined in 7.2:

Claim 2: The expected size of the cultural region an Energiser belongs to is larger than that which a non-energiser belongs to. De-energisers belong to smaller regions.

The emergence of cultural regions during the simulation depends on the occurrence of imitation events. So we might expect some similarity between the metrics Frequency of being imitated and Size of agent's region, and this is born out by comparing the simple Belongingness model in *Figure 38(a)* to that in *Figure 33(a)* - both show a

peak around low q , short half life. But the resemblance is not present when we compare the simple Competence model in *Figure 38(b)* to *Figure 33(b)*.

The charts in the appendix (B.2) make it clear that the results landscapes for Size of agent's region are not as smooth as those for Frequency of being imitated. In few cases are there single peaks dominating the landscapes. If this makes us pessimistic for the systematic search locating any interesting models for claim 2, the search results (B.3.2) bear this out. With our first attempts we were unable to obtain any points where a non-zero score was achieved. We reduced the confidence level for the summary score from 95% to 80% - meaning the chances of at least one type I error are 0.2 - and obtained one point for scenario B=E at (half life = 3465.4, $q/F = 2$) which scored 2.

There is, then, negligible support for claim 2 from the various agent-energy models compared to that for claim 1. It is possible, however, that more simulation replications might have improved this situation, but with no indication that this will be the case, we have no warrant for the spending the computer processing time on producing them.

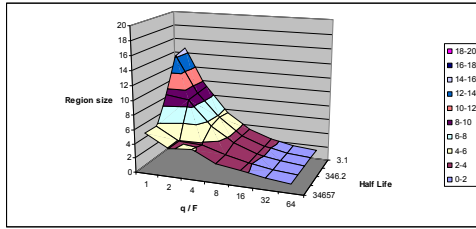

(a) Region size: $B=1$

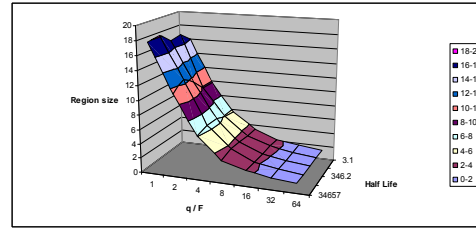

(b) Region size: $C=1$

Figure 38 Size of agent's region, given by q / F and half life, for the agent-energy model

With (a) energy based on Belongingness (i.e. on number of trait matches); (b) energy based on Competence (i.e. fitness). Comparisons are invited with Figure 33.

8.5 Claim 3: Improvement in fitness

Our third claim derived from Cross and Parker is:

Claim 3: Populations / Organisations / Social groups with energisers outperform those with non-energisers, which in turn outperform those with de-energisers.

Testing claim 3 requires a different process to those for claims 1 and 2. For claims 1 and 2 comparisons were made within a population between the Energiser/De-energiser and the Others. For claim 3 comparisons are made between model populations: those with an Energiser; those with a De-energiser; and those with neither. If claim 3 applies to these models, Energiser-populations should reach higher fitness than those without, which should beat those with a De-energiser. Using a significance level chosen to give us 80% confidence in the summary score, systematic

t-tests were performed for each value of q / F and half life. The tests were summarised using the following scores:

Table 4 Tests scoring for Claim 3

Score	Explanation
0	None of the following passed
+1	De-energiser-population (D) > Energiser-population (E)
+2	$E > D$
+4	Non-energiser, non-de-energiser population (N) > E
+8	$N > D$
+16	$E > N$
+32	$D > N$

Claim 3 requires $E > N > D$, or a score of 26 ($=16+8+2$). The complete opposite ($D > N > E$) would score 37 ($=32+4+1$). If instead Energisers and De-energisers both undermined fitness, so that the populations without them did best ($N > E$ & $N > D$), this would score 12. In the systematic search results, none of these numbers appear for any of the models tested at any of the parameter values. So we find no support for any of these three hypotheses.

It will be noted also, that where positive scores do appear in the tables, they bear no similarity to adjacent points in parameter space. The impression given is that pure chance governs these test results. Using the model options of sampling interaction participants by stratifying by Expected Gain in Energy did not improve this situation.

Thus we find no interesting relationships between the presence of energisers or de-energisers and the fitness level reached by a population of agents during a simulation run.

8.6 Summary for the agent-energy model

The agent-energy model is the simplest of our energy models, and can be viewed as having the Axelrod Cultural Model as a special case. Results using a very short energy half life while varying q bore this out, and so increase confidence in the functioning of this simulation model.

Tests using the metric “Frequency of being imitated” identified areas of the (q/F) -versus-half-life parameter space for which claim 1 held. That is, Energisers beat the other agents, who in turn beat De-energisers. Such an area could not be identified for models using Autonomy as the energised component of the payoff function. These areas were roughly:

- moderate to long half life, and;
- low to moderate q / F .

Tests using Size of agent’s region generated no support for claim 2. There was no intelligible support for claim 3 either, in any of the models tested and for any of the parameter space.

More simulation replications might improve the picture for both claims 1 and 2, but we have no guarantee of this, and no indication of how many replications. Claim 3 may require something even more - a different definition of fitness. For the function chosen, though simple to program and fast to run, is so easy to optimise that agents may be adopting fit culture too quickly for energisers and de-energisers to have an effect. We will return to the question of a suitable benchmark fitness function in our final discussion 12.5.3 and appendix section F.7.

The following table summarises where the claims held for the agent-energy model.

Table 5 Approximate parameter ranges where claims tests held

Model	Payoff Function	Claim 1 (C.L. 95%)	Claim 2 (C.L. 80%)	Claim 3 (C.L. 80%)
AgentE	B=E	HL \geq 346 $1 \leq q/F \leq 16$	Energisers beat 19 at (HL = 3465.4, $q/F = 2$).	
	B=E, A=1	HL \geq 346 $1 \leq q/F \leq 16$	None	
	B=E, C=1	HL \geq 346 $2 \leq q/F \leq 4$	None	None
	A=E	None	None	
	A=E, B=1	None	None	
	C=E	None	None	None
	C=E, B=1	HL \geq 346 $1 \leq q/F \leq 8$	None	None

Chapter 9 Energy applied to features

9.1 Introduction

In this chapter we examine the second of our energy models – in which each agent has two energy levels, one for each of its cultural features. As before our experimental factors include:

- the number of traits, q ;
- the decay rate, represented here in terms of energy “half life”;
- the method of calculating payoffs, including the way in which energisers affect the energy payoffs of others, and;
- the strength of energisers’ effects on payoffs.

We compare the behaviour of the feature-energy model to the agent-energy model discussed in Chapter 8. This includes testing the three claims. A fuller set of charts for the experiments is given in Appendix C.

9.2 Attempting to relate feature-energy and agent-energy models

We start our comparisons with energy payoffs based on Belongingness – based on the proportion of cultural features interacting agents have in common. This payoff

function was one of the most successful when we tested the three claims on the agent-energy model in Chapter 8. Points are plotted as before for all values of q / F in $\{1, 2, 4, 8, 16, 32, 64\}$ and half lives in $\{3.1, 34.3, 346.2, 3465.4, 34657, 346573.2\}$.

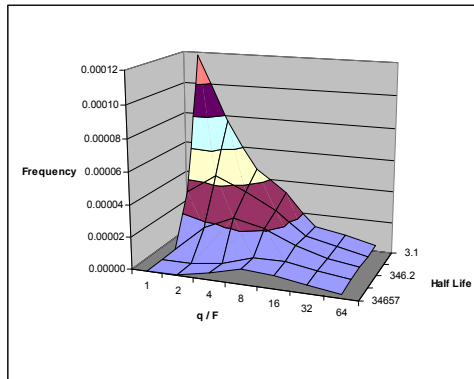

(a) FeatureE

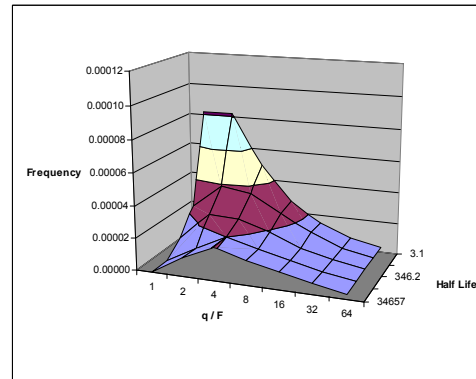

(b) AgentE

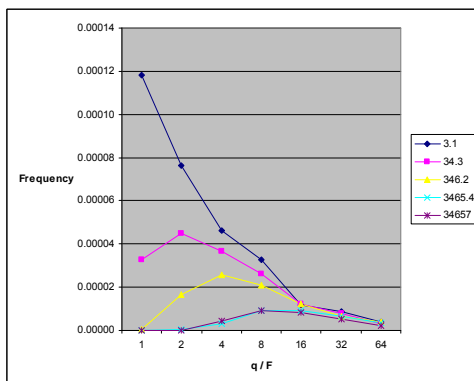

(c) FeatureE

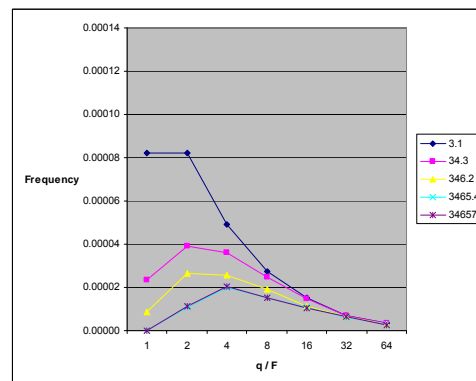

(d) AgentE

Figure 39 Comparing the feature-energy model (“FeatureE”) to the agent-energy model (“AgentE”) for Frequency of being imitated

At the shortest Half Life Frequency of being imitated peaks higher in FeatureE. As Half Life increases peaks in both models occur at higher values of (q/F) .

We compare the frequency-energy model to the agent-energy model for Frequency of being imitated (Figure 31) and Size of agent’s region (Figure 40), and look at the % difference between the results for the two models (Figure 41). For both measures, we

see peaks for relatively low q / F and the shortest half life. The peaks in the feature-energy model (a) are higher than those in the agent-energy model (b). For longer half lives, however, the agent-energy model achieves higher values for Frequency of being imitated, as indicated by the points below zero in *Figure 41(a)*, though the difference diminishes as q / F increases.

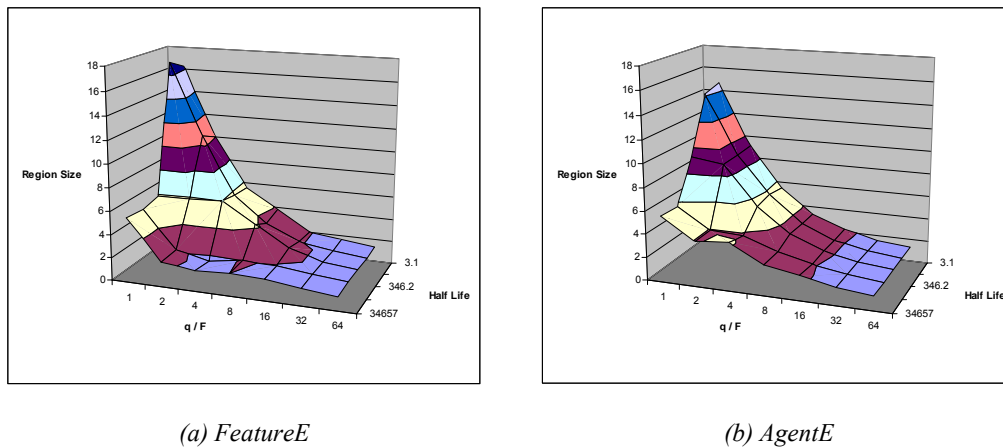

Figure 40 Comparing the feature-energy model (“FeatureE”) to the agent-energy model (“AgentE”) for Size of agent’s region

Size of agent’s region peaks higher in FeatureE.

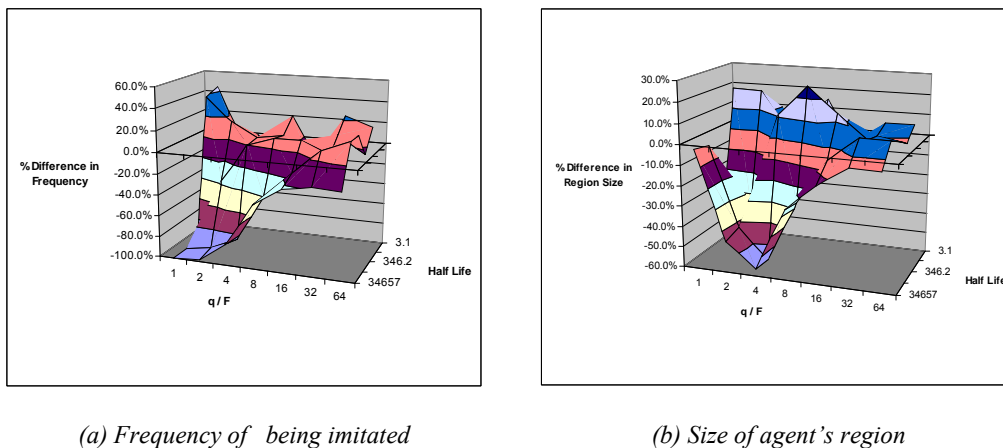

Figure 41 % difference between the feature-energy model (“FeatureE”) and the agent-energy model (“AgentE”)

For Frequency of being imitated (a) and Size of agent’s region (b).

Why are the two models different in their behaviour? In the agent-energy model each agent has an energy level. In the feature-energy model an agent has two energy levels – one for each cultural feature. In the feature-energy model interaction events yield separate payoffs for a participant’s features. In the agent-energy model there is only one payoff per participant. *Figure 42* summarises the possible payoffs from interaction events using just Belongingness as the payoff function, and just two features. (For now, we ignore possible energising/de-energising effects on the payoffs.)

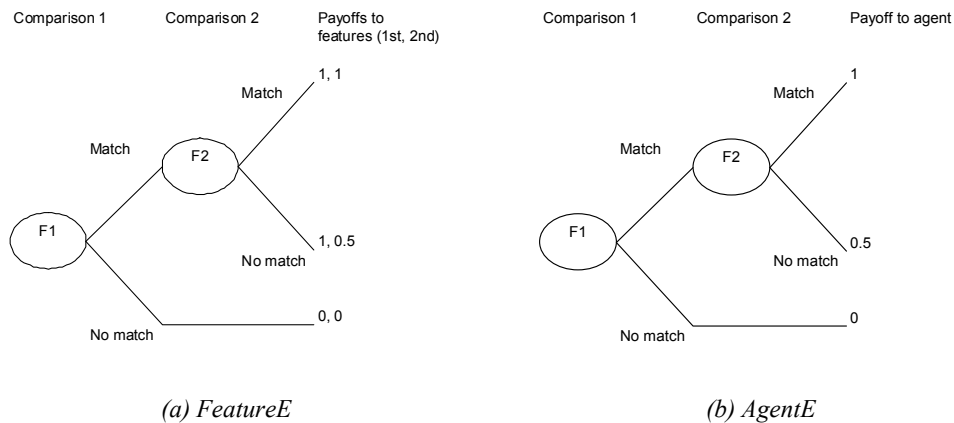

Figure 42 Energy charges due to Belongingness in the feature-energy model (“FeatureE”) and the agent-energy model (“AgentE”)

Note that payoffs differ in the case when only the first feature comparison results in a trait matches.

In the feature-energy model if both feature comparisons result in matches, the payoffs received are 1 for the first feature compared, and 1 for the second. If only the first results in a match, then the payoffs are 1 for the first feature and $(1+0)/2 = 0.5$ for the second. A payoff of 1 will recharge any previous energy level for the second feature, since at least one iteration has passed since the last interaction event, and hence even an energy level of 1 will have decayed by now. A payoff of 0.5, however, will only raise the level on a feature if its previous level was less than or equal to 0.5 or has had

sufficient time to decay below 0.5. In the case of an energy level of 1, this time is the half life. It is possible, then, for an agent's two features to differ in whether or not they are recharged, and, if so, to what level. These distinct levels will then play their role in deciding whether future interaction events can result in recharging.

The features' energy levels play another important role in the feature-energy model. When choosing which feature to use for the first comparison, sampling is stratified by expected gain – the difference between a feature's last charge and its current, decayed level. If the previous interaction has resulted in charging to 1 for one feature, and 0.5 for the other, the difference for the former feature will be greater than the difference for the latter. Thus the feature decaying from 1 has greater chance of being picked for the first comparison. This is important, because it is the second feature compared that is subject to imitation. The energy level on the first feature compared determines only whether that feature can be recharged. If the second feature is compared and does not result in a match, the energy level on the second feature determines whether or not an imitation event occurs.

The number of traits, q , affects the ratio between occurrences of double feature matches (delivering payoffs of 1 in AgentE and 1,1 in FeatureE) occurrences of the single matches that can lead to imitation (payoffs 0.5 and (1, 0.5) respectively). Once the simulation run starts the chances of occurrence will vary as the agents change their cultural capital and their relative energy levels, and there will be variation about any mean. But at the start of a run the expected probabilities are given by Table 6, for models with $F=2$ cultural features. Among successful IRs the number of single matches is $(q-1)$ times the number of double matches, but the number of unsuccessful

IRs is $(q-1)$ times the number of successful ones. So as q increases, double and single matches become ever less of a factor in the models (*Figure 43*). At moderately long Half Life the features receiving charges of 1 take moderate lengths of time to decay sufficiently for a new payoff of 0.5 to beat them. So at low q , the many double matches obstruct the possibility of single matches and imitation. At higher q , the single matches have more chance, and hence we see a rise in imitations. But higher q also means fewer single matches relative to failed IRs. So after a peak imitations falls as q increases.

Table 6 Initial Probabilities of Interaction Outcomes

	Comparison		Payoffs		Initial
	1	2	AgentE	FeatureE	Probability
Double Match	1	1	1	1, 1	$\left(q \times \frac{1}{q} \times \frac{1}{q}\right)^F = \frac{1}{q^2}$
Single Match	1	0	0.5	1, 0.5	$\frac{1}{q} \times \left(q \times \frac{1}{q} \times \frac{q-1}{q}\right) = \frac{q-1}{q^2}$
One Match - but not first	0	1	0	0	$\left(q \times \frac{1}{q} \times \frac{q-1}{q}\right) \times \frac{1}{q} = \frac{q-1}{q^2}$
No Matches	0	0	0	0	$\left(q \times \frac{1}{q} \times \frac{q-1}{q}\right)^F = \left(\frac{q-1}{q}\right)^2$

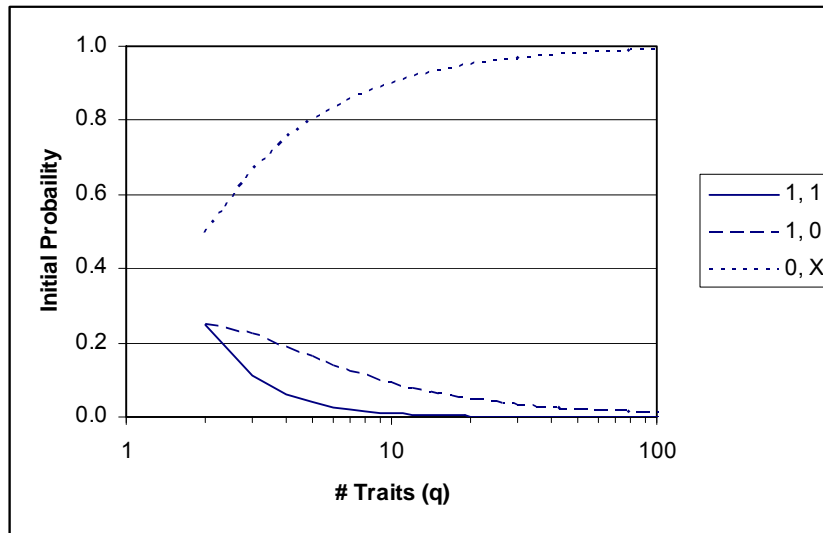

Figure 43 *Expected initial probabilities for successful IRs*

With double matches (“1, 1”) and single matches (“1, 0”) - and unsuccessful IRs (“0, X”) - either no matches, or first match failing.

In the feature-energy model the extra 1 in the (1, 0.5) payoff reduces the amount of these imitation events at moderate Half Life from those seen in the agent-energy model. But this difference between the models diminishes as q increases - as was seen in *Figure 41(a)* - since with successful IRs becoming rarer there is more time between them for charge to decay. At low Half Life this difference disappears, since the typical time between IRs is more than adequate for energy levels to decay below 0.5.

However, at $q=2$ and low Half Life there is a difference, with FeatureE peaking approximately 40% above AgentE. This may be a result of the differences in how the models select features. In AgentE with no energy difference between features they are selected with uniform chance. In FeatureE the respective chances of being selected first are a function of the original charged-up levels of the features, the times since they are charged up, and the decay rate (*Figure 44*). Suppose an imitation event

results in both features being updated at the same time. Since their payoffs are in the ratio $1:0.5 = 2:1$, the second feature has chance $1/3$ of being selected to be the first feature in the next IR involving this agent. So the chances are that the feature that has just been changed through imitation will be the next one to be changed in a future imitation event. Also, its charge level decays from 0.5 and so will be beaten by payoffs of 0.5 that might not have beaten the charge level on the feature decaying from 1. At longer Half Life, there is more chance of a 0.5 payoff failing to beat a charge decaying from 1, and so more scope for the two features being recharged at different times. This allows for the Expected Gain on a feature decaying from 0.5 to overtake that on a feature decaying from 1, raising the chance of the features switching comparison order in the next IR. This leaves it unclear, still, why FeatureE has a higher peak at $q=2$, Half Life =3.1. But these differences in the details of the models' behaviour offer some suggestions for where explanations may lie.

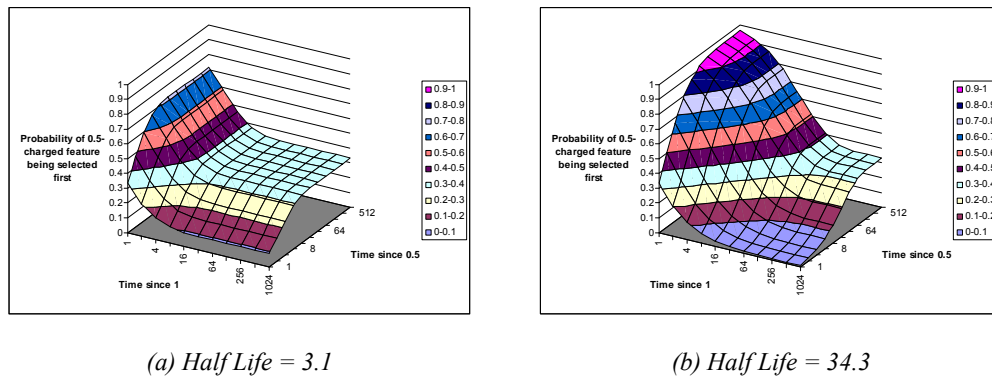

Figure 44 Probability of a feature decaying from 0.5 being selected ahead of one decaying from 1
 The selection is stratified by Expected Gain, itself a function of the original energy charge and the time since the feature was recharged. Two decay rates are shown.

9.3 Testing the claims in the feature-energy and agent-energy models

We turn now to testing our three claims on the feature-energy model. The tests are those employed in Chapter 8, and the test results are scored using the same system. For test 2 every combination of q / F and half life scored 0 – not unlike the agent-energy model. For test 3, no sensible patterns appeared in the scores – just like the agent-energy model. Consequently we exclude them further from this chapter and focus on the test of claim 1.

Figure 45 shows test scores using Frequency of being imitated. The feature-energy model is compared with the agent-energy model results seen in Chapter 8. Payoff functions based on Belongingness, Belongingness & Competence, and Competence alone were tested. Payoffs based on Autonomy were not included since the internal workings of the feature-energy model made it particularly difficult to calculate autonomy for this model.

Comparing FeatureE and AgentE it is clear that the latter gave positive results for wider ranges of the parameter space. There are more points that score 3 – denoting that for these values of q / F and half life, energisers were imitated more often, and de-energisers less often, than neutrals. However, without more parameter values being tested - and perhaps also more replications - we cannot say much more than this.

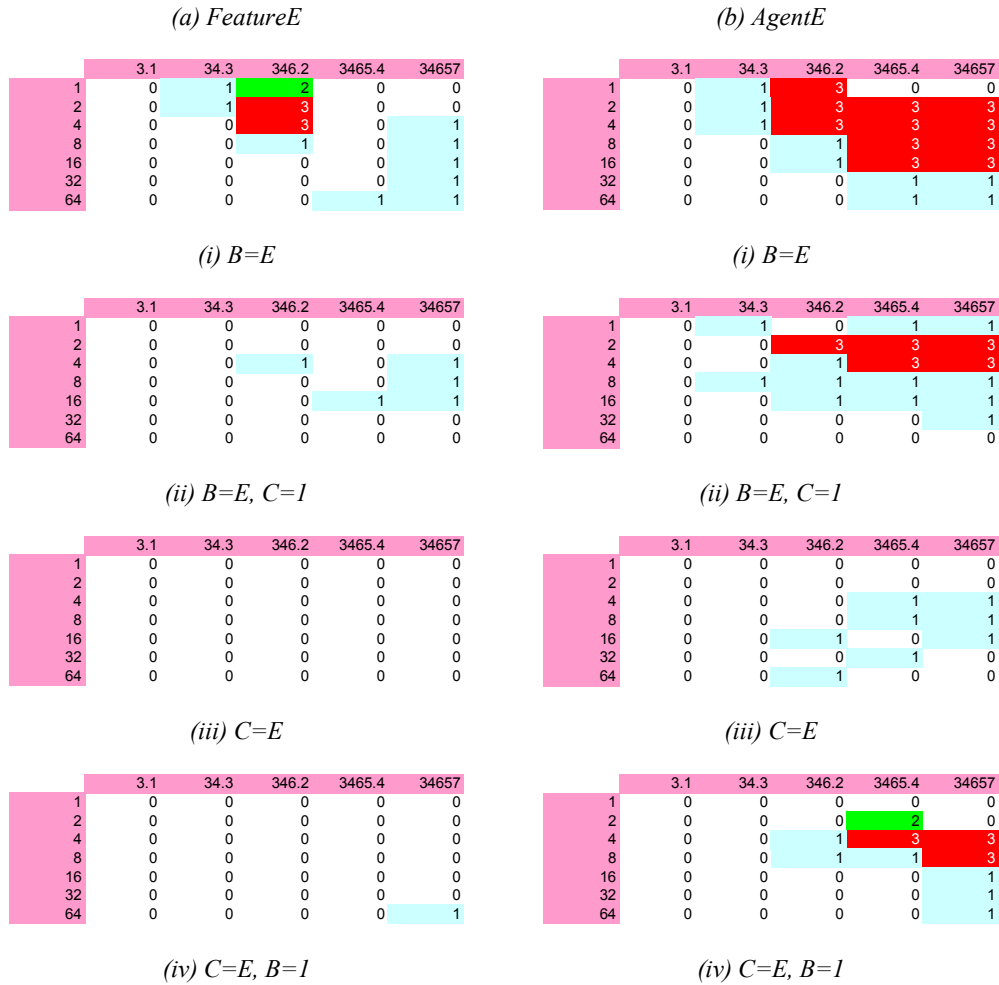

Figure 45 Test scores using Frequency of being imitated for the feature-energy model

("FeatureE") and the agent-energy model ("AgentE")

Various payoff functions are tested.

9.4 Summary for the feature-energy model

We tested the feature-energy model and compared its behaviour to that of the agent-energy model. Behaviour was similar, but not identical. The workings of the feature-energy model allow differences to emerge between agent features in energy levels and

expected gain, and this may explain the ways in which the model behaves differently from the agent-energy one. The explanations were not easy to trace, however.

For the claims tests the situation is easy to summarise (Table 7). Using the Frequency of being imitated for several payoff functions, we found a number of points in parameter space for which energisers beat neutrals, and neutrals beat de-energisers. Thus claim 1 holds at some parameter settings in the feature-energy model. However, these points were fewer in number than those seen in the agent-energy model. No such points were found for claim 2 – a slightly more pessimistic position than that seen in the agent-energy model. Meanwhile for claim 3 no sensible results were found – an unsurprising outcome given that the agent-energy model produced the same.

Table 7 Approximate parameter ranges where claims tests held

Model	Payoff Function	Claim 1 (C.L. 95%)	Claim 2 (C.L. 80%)	Claim 3 (C.L. 80%)
FeatureE	B=E	HL = 346 $2 \leq q/F \leq 4$	None	
	B=E, C=1	None score 2 or 3	None	None
	C=E	None	None	None
	C=E, B=1	None	None	None

Chapter 10 Energy applied to IR Memories

10.1 Introduction

The final and most sophisticated energy model applies energy to memories of interaction ritual experiences. In the Interaction Ritual Agents Model (IRAM) agents construct an interaction ritual event which brings each participant an energy payoff. The memory of this event can then be added to an agent's IR Memory, replacing an older memory as it does so. As discussed in 6.5.4, this replacement is based on both the current energy levels of older memories and on the degree of similarity they have with the current event. This latter restriction was introduced to prevent loss of cultural diversity within the IR Memory, which had resulted in agents with an m -item IR Memory converging on m copies of the same set of traits.

Once again our experimental factors include:

- the number of traits, q ;
- the decay rate, represented here in terms of energy “half life”;
- the strength of energisers' effects on payoffs.

We restrict ourselves to just two payoff functions – both based on Belongingness, but one including Competence so that claim 3 may be tested. To aid appreciation of the IRAM results we compare them with those of the agent-energy model. The IRAM has one extra, very important parameter – the size of an agent's IR Memory. Preliminary

experiments suggested that early increases in m (from the $m=1$ similar to the AgentE model) produced significant changes in homogenisation in the population, but by $m \geq 7$ these changes were less dramatic – as detailed in E.2.2. Consequently we focus on $m=8$ for our comparisons. Appendix D contains more of these charts.

Later in this chapter we turn to a version that uses the IR Memory for sampling traits but not for sampling interaction participants. Thus it represents an intermediary between the agent-energy model and the IRAM, and might help us understand the role played by increasing memory size. Appendix E contains charts for this.

Finally, we introduce some entropy-based metrics that only apply to multi-item IR Memory models. These metrics being more unusual, our discussion of the results is more speculative, concluding with some suggestions for further empirical hypotheses.

10.2 Testing the claims

Claim 1 – based on the Frequency of being imitated – held for a much wider set of parameter values in the IRAM than in the agent-energy model. *Figure 46*, based on 40 simulation replications for both models, shows claim 1 holding for nearly all values of $(q / F) > 2$ and all half lives between 34.3 and 34657.

	3.1	34.3	346.2	3465.4	34657
1	0	3	3	2	1
2	0	3	3	3	0
4	0	3	3	3	3
8	1	3	3	3	3
16	1	3	3	3	3
32	0	3	3	3	3
64	0	3	3	3	3

(a) IRAM $m=8, B=E$

	3.1	34.3	346.2	3465.4	34657
1	0	1	3	0	0
2	0	1	3	3	3
4	0	1	3	3	3
8	0	0	1	3	3
16	0	0	1	3	3
32	0	0	0	1	1
64	0	0	0	1	1

(b) AgentE, $B=E$

Figure 46 Test scores using Frequency of being imitated for the IRAM

Test scores using Frequency of being imitated for the IRAM with $m=8$ memory size, and the agent-energy model (“AgentE”). The payoff function is based on Belongingness.

Claim 2 – based on the Size of an agent’s region – did not hold in these experiments when we used 40 replications (Figure 47), though the one point at which we generated a non-zero score has the same half life as that which generated the only non-zero score in AgentE. The IRAM results occurred at higher values of q / F , however.

	3.1	34.3	346.2	3465.4	34657
1	0	0	0	0	0
2	0	0	0	0	0
4	0	0	0	0	0
8	0	0	0	0	0
16	0	0	0	0	0
32	0	0	0	1	0
64	0	0	0	0	0

(a) IRAM $m=8, B=E$

	3.1	34.3	346.2	3465.4	34657
1	0	0	0	0	0
2	0	0	0	2	0
4	0	0	0	0	0
8	0	0	0	0	0
16	0	0	0	0	0
32	0	0	0	0	0
64	0	0	0	0	0

(b) AgentE, $B=E$

Figure 47 Test scores using Size of agent’s region for the IRAM

Test scores using Size of agent’s region for the IRAM with $m=8$ memory size, and the agent-energy model (“AgentE”). The payoff function is based on Belongingness.

For this model we tried running more simulation replications, eventually collating 138 for each parameter combination. Comparing Figure 48(a) with Figure 46(a) and Figure 48(b) with Figure 47(a) we see the scores improve with more replications. This is particularly useful in the case of Size of agent’s region, where three combinations emerge at which claim 2 holds.

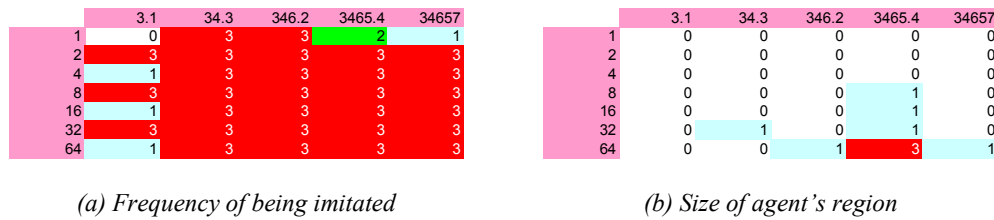

Figure 48 Test scores for the IRAM with 138 simulation replications

Test scores for the same IRAM as before, but this time with 138 simulation replications, instead of 40.

Compare (a) with Figure 46(a), and (b) with Figure 47(a).

We also tried a payoff function that included a component for Competence as well as Belongingness. Energising relates to alteration of Belongingness as before, but payoffs are weighted by a fitness function – “B=E, C1” in the terminology of Chapter 8. Comparing Figure 49(a) with Figure 46(a) and Figure 49(b) with Figure 47(a) we see the scores are mostly the same for Frequency of being imitated. For Size of agent’s region there is one extra non-zero score.

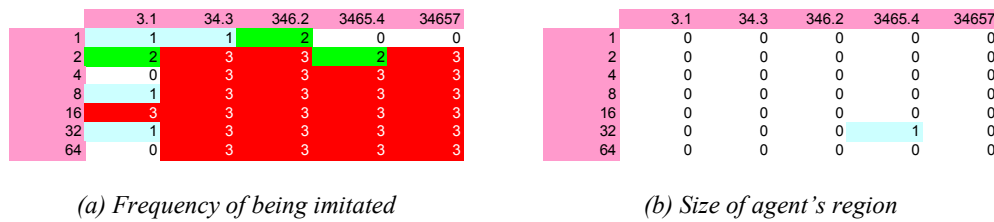

Figure 49 Test scores for an IRAM with payoff function based on Belongingness and Competence

(B=E, C=1)

80 simulation replications were run. Compare (a) with Figure 46(a), and (b) with Figure 47(a).

Figure 50 compares scores for claim 3, using the scoring system introduced in Chapter 8. Like the agent-energy and feature-energy models the IRAM failed to produce any meaningful patterns.

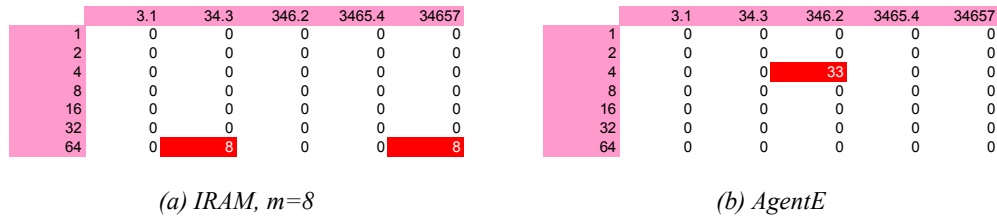

Figure 50 Test scores for claim 3 for an IRAM

(a) and an agent-energy model (b) with payoff function based on Belongingness and Competence

($B=E$, $C=1$). 80 simulation replications were run for the IRAM; 20 for AgentE.

10.3 How the IRAM behaves

There are some remarkable differences in behaviour between the IRAM and the agent-energy model. In *Figure 51* the landscape for Frequency of being imitated is quite a different shape – there is little change in the IRAM with respect to (q / F) , and half life is the only important factor. Note also that the scale of the highest values is approximately 100 times that of those in the agent-energy model.

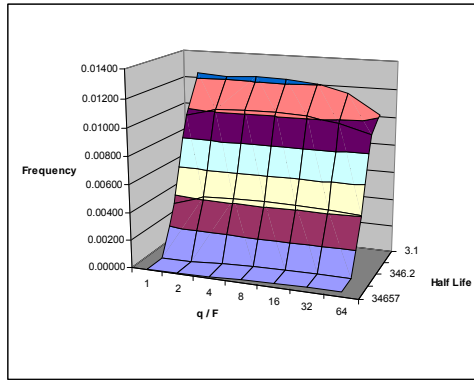

(a) IRAM $m=8, B=E$

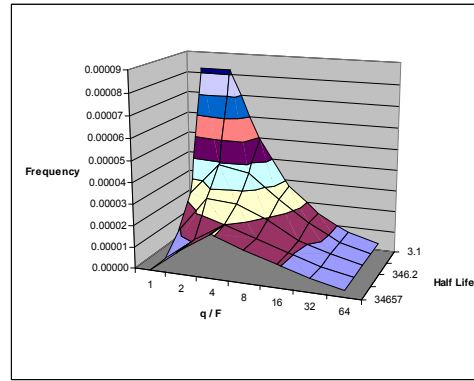

(b) AgentE, $B=E$

Figure 51 Comparing the IRAM with $m=8$ memory size to the agent-energy model (“AgentE”) for Frequency of being imitated

Frequency of being imitated lacks the peak of AgentE (and FeatureE). Half life is clearly a factor, but number of traits q shows little influence.

Region sizes are limited to the range 1 to 20 in a 20-agent population, so no such differences in scale appear in *Figure 52* for Size of agent’s region. However the landscape for the IRAM is still quite different. Values for $(q / F) = 1$ follow one pattern with respect to half life, while a ridge appears at half life = 346.2, decreasing in height as (q / F) increases. At other points with $(q / F) > 1$, the Size of agent’s region averages very low (across 138 simulation replications) – just slightly over 1 agent in a region.

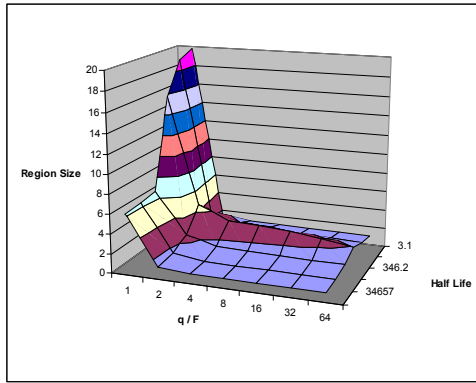

(a) IRAM $m=8, B=E$

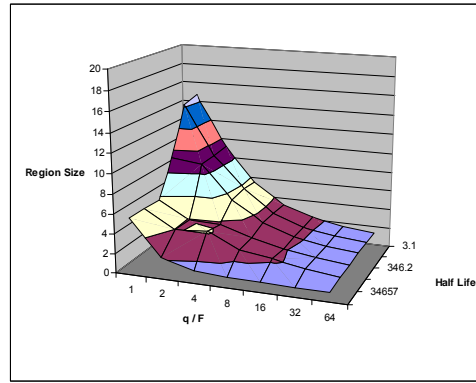

(b) AgentE, $B=E$

Figure 52 Comparing the IRAM with $m=8$ memory size to the agent-energy model (“AgentE”) for Size of agent’s region

For $q / F > 1$ the IRAM produces only regions of size 1 – except when half life is 346.3, at which we see a small amount of region growth. Half life is also a factor when $q / F = 1$.

Comparing charts (a) in *Figure 51* and *Figure 52* to (a) and (b) respectively in *Figure 48* we may be left with the feeling that the shapes of the landscape charts provide no insight into the location of non-zero test scores. The tests for claims 1 and 2 are passed in parameter ranges that yield very low values for Frequency of being imitated and the Size of agent’s region. The effects of energisers and de-energisers are not contingent on the scale of these output measures for agents in general.

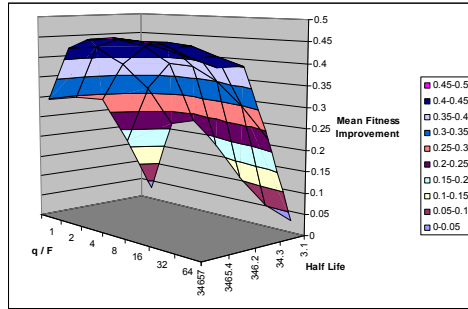

(a) IRAM $m=8$, $B=E$ & $C=I$

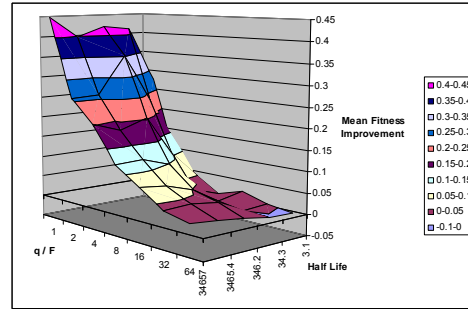

(b) AgentE, $B=E$ & $C=I$

Figure 53 Comparing the IRAM with $m=8$ memory size to the agent-energy model (“AgentE”) for Fitness Improvement

In the IRAM performance peaks for moderate half life and moderate (q/F). In AgentE a peak for half life is difficult to discern but may be there. But the relationship with (q/F) is dramatically different. As in Figure 50, 80 replications were run for the IRAM; 20 for AgentE.

Turning to models with payoff functions that include Competence, we find in Figure 53 an important difference in the performance of the IRAM and AgentE in improving fitness. The IRAM clearly has values of half life and (q/F) at which fitness improvement is maximal. For both factors this occurs around the middle of the parameter range. The best half life is much harder to discern in AgentE – though more simulation replications (than the 20 run) might confirm its existence. But fitness improvement clearly falls with increasing (q/F) in AgentE – there is no exception to this.

Now that we have two IRAMs – each based on a different payoff function – we can compare them for the other two metrics. We find little difference for Frequency of being imitated (Figure 54(a) versus Figure 33(a)). But for Size of agent’s region adding Competence to the payoff function has produced a landscape (Figure 55 (a)) that appears like a cross between those from the other IRAM (Figure 52(a)) and the

AgentE with the simpler payoff function (Figure 52(b)). It has the peak at short half life and low (q/F) seen with the AgentE, but also has the ridge around half life = 346.2 seen in the other IRAM.

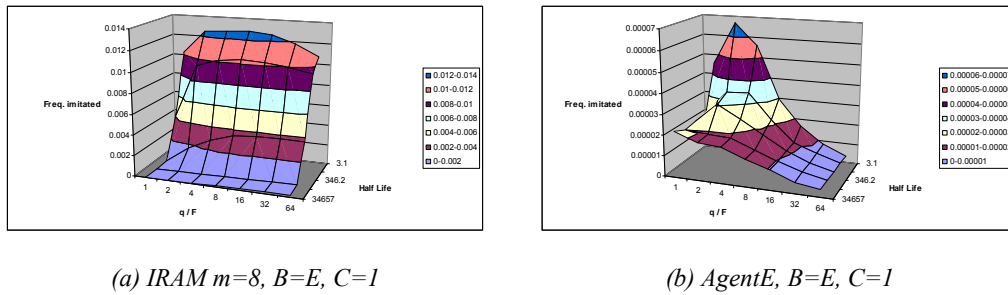

Figure 54 Frequency of being imitated for IRAM and AgentE –with payoff function based on Belonginess and Competence ($B=E, C=1$)

IRAM resembles the IRAM based on Belonginess in Figure 31(a) than either of the AgentE models.

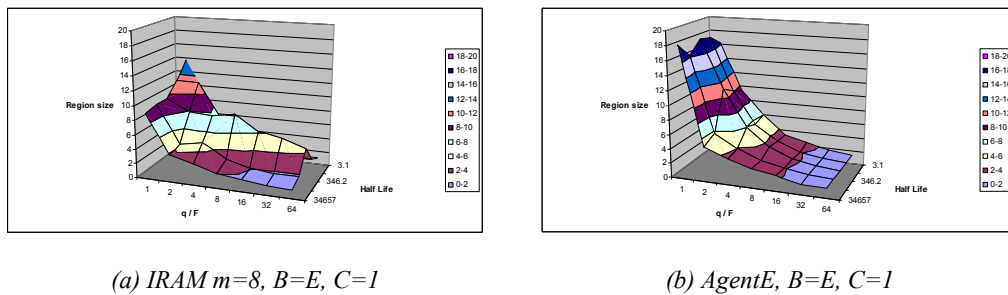

Figure 55 Size of agent's region for IRAM and AgentE with payoff function based on Belonginess and Competence ($B=E, C=1$)

This IRAM resembles both the IRAM and AgentE based on Belonginess in Figure 52 (though not the AgentE that uses the same payoff function).

10.4 Increasing the size of the IR Memory

To try to understand the dramatic differences between IRAM and AgentE we sought out intermediate models. The most obvious parameter to vary is the size of the IR Memory. However, the IRAM selects would-be interaction partners from the IR Memories of agents. This will have little point if memory size is set to 1 – only one interaction partner will be remembered at any one time. A simpler model is to select participants using unbiased random sampling from the whole population – the method used in the agent-energy model and feature-energy model. With this adjustment, then, the only uses for the IR Memory are in sampling cultural traits during interaction, and updating after interaction. It is this model (called the “IRM Model”) that we show results for in *Figure 56* (Frequency of being imitated) and *Figure 57* (Size of agent’s region) for memory sizes 1 to 8.

As we would expect, the charts for $m=1$ appear near identical to those for the agent-energy model (as seen in *Figure 33(a)* and *Figure 52(b)*). The agent-energy energy model is a one-memory-row special case of our simplified IRM Model. Comparing the figures for the IRM Model with $m=1$ to those of AgentE we found all differences in Size of agent’s region were well within a 95% confidence interval. Comparing Frequency of being imitated is a little more problematic, since before being output by the simulation programs these figures are divided by the number of iterations run. AgentE was run for 40 000 iterations; IRAM and the IRM models for 200 000. Multiplying the figures back again the $m=1$ model again matched the AgentE model to a high degree – as suggested by simple comparison by eye of the landscape forms.

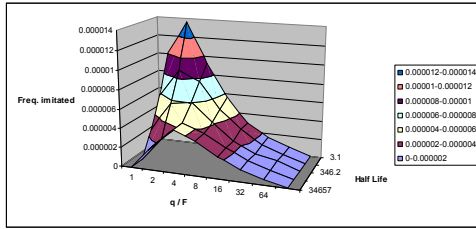

$m=1$

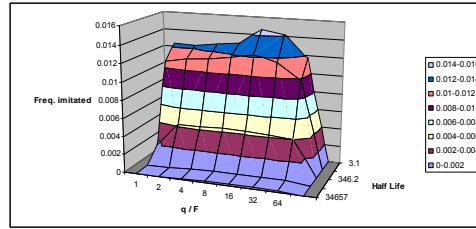

$m=5$

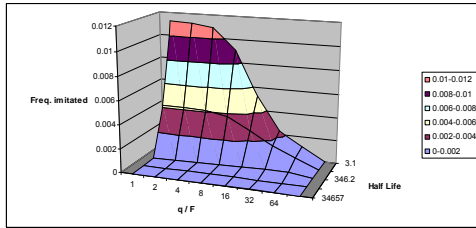

$m=2$

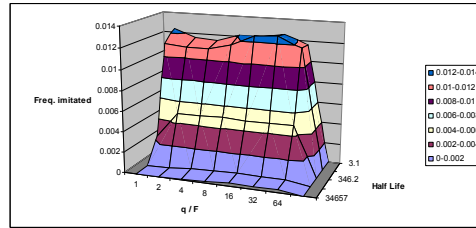

$m=6$

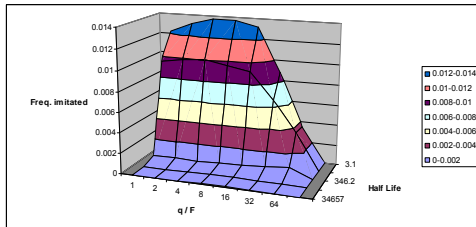

$m=3$

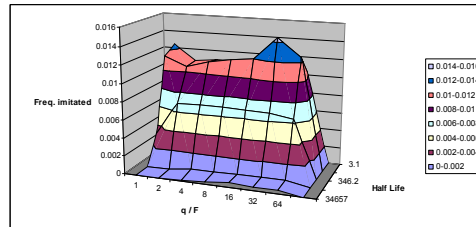

$m=7$

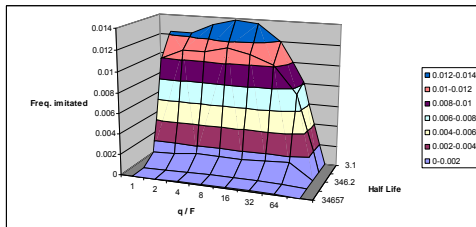

$m=4$

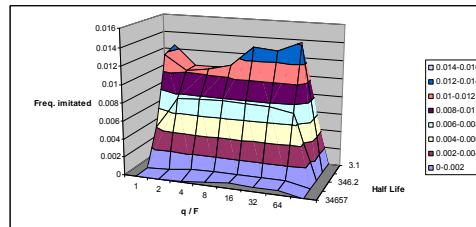

$m=8$

Figure 56 Frequency of being imitated for the IRM model with values of memory size m from 1 to 8

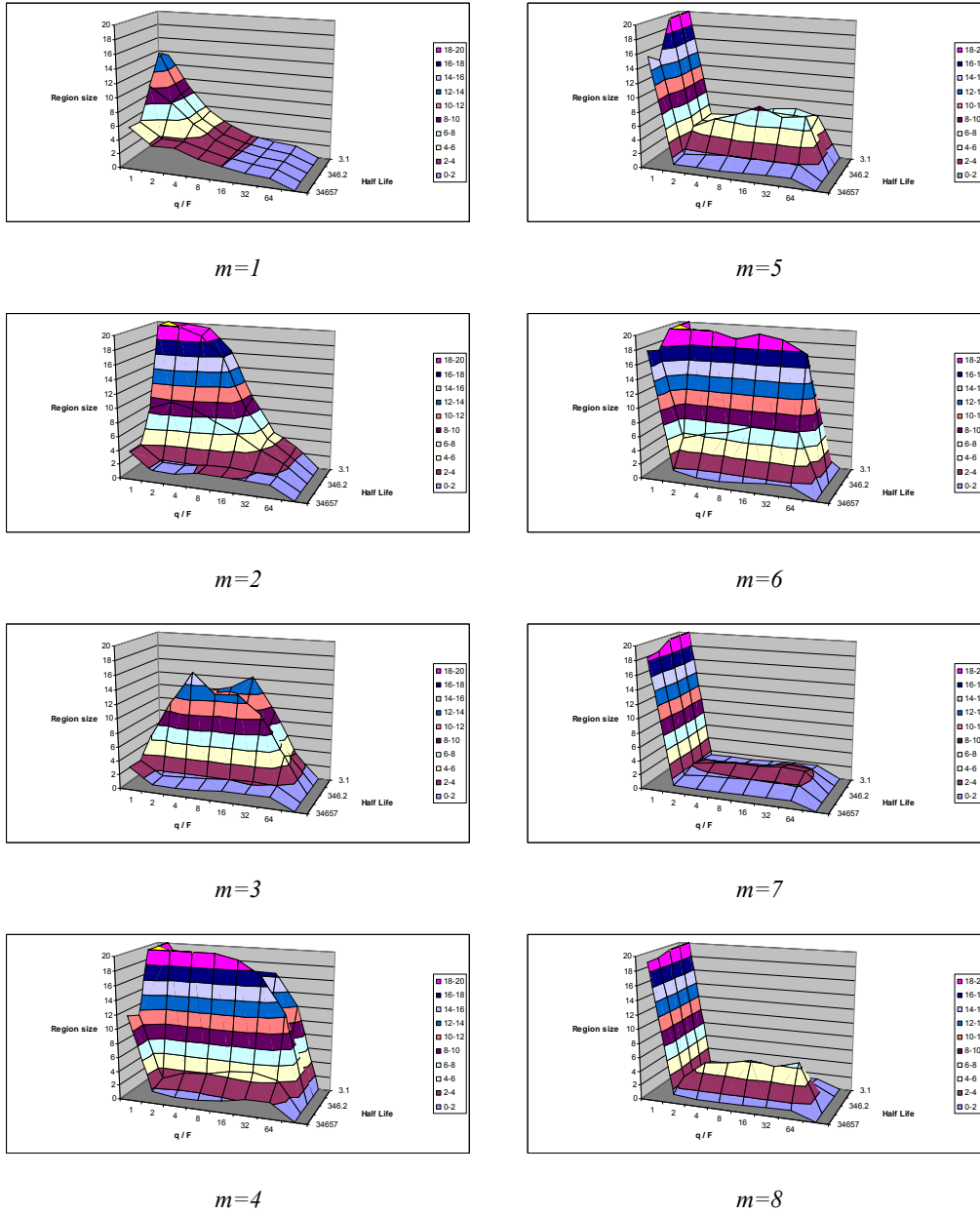
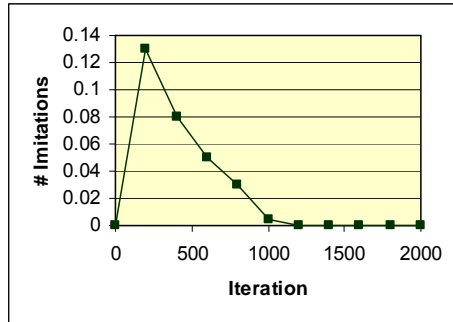

Figure 57 Size of agent's region for the IRM model with values of memory size m from 1 to 8

We notice, however, that the peak figures for Frequency of being imitated for $m \geq 2$ are approximately 1000 times those of $m=1$. The immediate reason for this is that the $m=1$ model converges to a static state well within the 200000-iteration runtime. The models for $m \geq 2$ do not. *Figure 58* demonstrates in a representative simulation run that

this emergence of a static state in the $m=1$ model can occur in little over 1000 iterations.



(a) Imitations over time, $m=1$

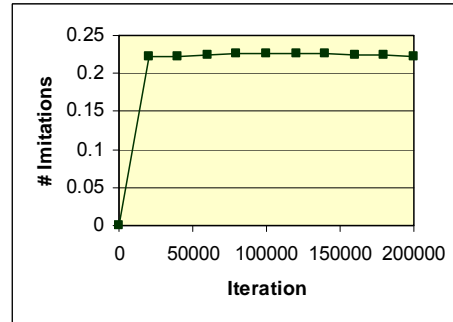

(b) Imitations over time, $m=2$

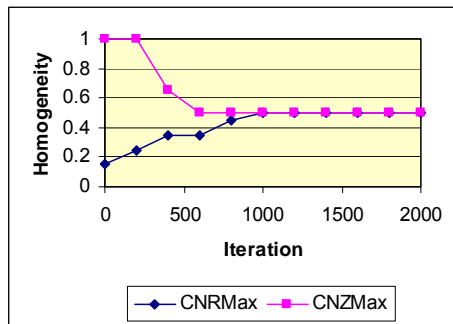

(c) Size of largest region, $m=1$

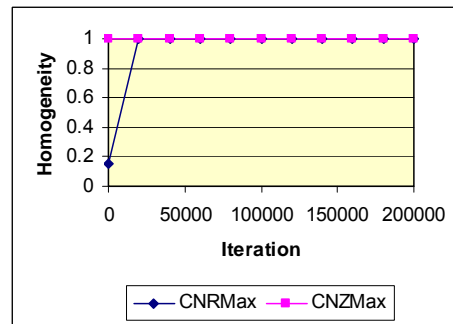

(d) Size of largest region, $m=2$

Figure 58 Representative runs of the IRM model

Number of imitations over time (a,b) and Size of largest region (c,d) for representative runs of the IRM model with values of memory size $m=1$ and $m=2$, $q=2$, $F=2$, half life = 346.2. Note the $m=1$ model goes static within 2000 iterations. The $m=2$ model is still in flux after 200 000 iterations, even though the agents remain in a single cultural region.

Turning now to Size of agent's region (Figure 57) we notice some dramatic changes as we increase memory size m – not least those between resulting in $m=6$ resembling $m=4$ but not $m=5$ which instead resembles $m=7$. (That is, the charts are not the wrong way round!) By $m=8$ the landscape is simpler to summarise. Agent's belong to a region incorporating nearly all the population when $q / F = 1$. At $q / F > 1$, however,

agents rarely form regions of size > 1 , except around the decay rate that corresponds to a half life of 3465. This “ridge” of larger region sizes occurs at lower values of m , though mostly around the shorter half life of 346. Again these charts provide no clue to what we find when we test the claims in the IRM (*Figure 59*). Interestingly we find the more sophisticated model, the IRAM, scored for wider parameter ranges than the IRM did (*Figure 48* versus *Figure 59*).

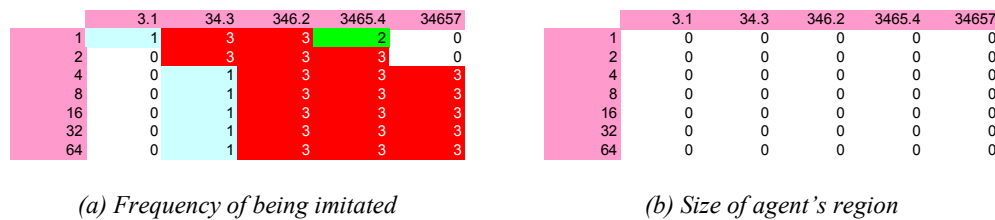
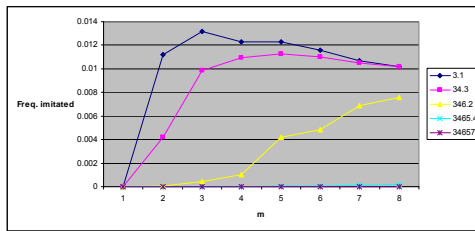

Figure 59 Test scores for claims 1 and 2 for the IRM with $m=8$ memory size

Test scores for claims 1 (a) and 2 (b) for the IRM with $m=8$ memory size. The payoff function is based on Belongingness. Note the differences with the more sophisticated model, the IRAM, in *Figure 48*, especially for (b).

For another angle on the importance of memory size m , consider *Figure 60*. To clarify things we choose different chart types here. (a) shows that at the two shortest half lives there exists a memory size at which the Frequency of being imitated peaks. The shape of the curve for the next half life suggests that it too may peak at some memory size > 8 . Results for the Size of agent's region are much stranger. At $(m=2, HL=3.1)$, $(m=2, HL=34.3)$, $(m=4, HL=3.1)$, $(m=4, HL=346.2)$ and $(m=6, HL=346.2)$ we have exceptionally large regions – mostly including the whole population of 20 agents. Most of these points stand out to a similar extent at other values of (q/F) . We can offer no explanation here for why these points stand out in this way – though we suspect it would be interesting to test a model with an IR-Memory update function

that did not attempt to preserve cultural diversity - the surprising peaks look like being artefacts of some modelling design decision. Instead we propose that the behaviours of the IRM as memory size increases should warn of the difficulties ahead to anyone considering another agent-based model with a bounded memory size like that of the IRM and IRAM.



(a) Frequency of being imitated

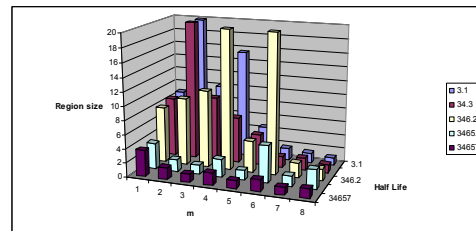

(b) Size of agent's region

Figure 60 Outputs from IRM with $(q/F) = 2$

Results shown by memory size m for each value of half life.

10.5 Analysis of Entropy in the Interaction Ritual Agents

Model (IRAM)

Agents in the Interaction Ritual Agents Model (IRAM) have multi-row IR Memories in which they maintain a record of past interaction ritual experiences: who initiated the interaction; who received it; what traits were focussed on for each cultural feature. The information in the IR Memory is sampled to determine new interaction ritual events, with sampling stratified by Expected Gain. This means that for every possible state (i.e. every possible participant or cultural trait) there is a probability of being sampled. From this probability we can calculate a contribution to Shannon entropy for

that state, a commonly used definition of *uncertainty* (Mackay, 2003, p.32). Entropy is given as:

$$H_b(X) = \sum_{x \in A_x} -p_x \times \log_b p_x$$

where

X is some store of information;

x is a possible state for that store (in our case, an agent IR participant, or a cultural trait)

p_x is the probability of state x being selected during sampling stratified by Expected Gain;

A_x is the set of possible states for that store (the set of agent participants, or the set of cultural traits);

b is the base of the logarithm - usually base 2, making the units of information content and entropy binary digits or “bits”. Bits have no particular meaning for us in this model, so we choose bases more relevant to the metric concerned;

$p \log(p)$ is taken to be 0 when $p = 0$.

In this section we suggest what can be learnt from the level of uncertainty. We calculate four such entropy output metrics (Table 8).

Table 8 Entropy metrics explained

Metric	Explanation
InitiatorEntropy	Based on probability of being selected to initiate an interaction. Selection is from all IR Memory rows in the population where the

	agent listed in the Ego - or initiator - position is the IR Memory's owner.
EgoEntropy	Based on probability of selecting an agent from the Ego position in IR Memory. One entropy value is calculated for each agent IR Memory, and a population mean is also output.
AlterEntropy	Based on probability of selecting an agent from the Alter - or recipient - position in IR Memory. One entropy value is calculated for each agent IR Memory, and a population mean is also output.
CCEntropy	Based on probability of selecting a cultural trait from a feature position in IR Memory. One entropy value is calculated for each feature, then summed up to give the total Cultural Capital (CC) information content of the agent's IR Memory. Then a population mean is output.

For the IRAM we have results for two scenarios distinguished by their payoff function components (Table 9). See 6.6 and 6.7 for the definitions of the payoff function components, Belongingness and Competence, and the use of the energising parameter. In both scenarios we gave the agents IR Memory sizes of $m=8$. We ran 138 replications for B=E and 80 for B=E, C=1.

Table 9 IRAM scenarios explained

Code	Explanation
B=E	Payoffs based on Belongingness. Energising alters Belongingness
B=E, C=1	Payoffs based on Belongingness and Competence. Energising alters Belongingness

We show charts for the parameter ranges used already in other appendices, but place our two scenarios side-by-side (Figure 61). Note, to improve the display we have reversed the order of the half-life axis on the charts for EgoEntropy and AlterEntropy. Discussion of what the charts might mean follows.

Initiator Entropy

This metric is based on the probability of an agent being selected to initiate an interaction. Selection is from every IR Memory row in the population where the agent listed in the Ego - or Initiator - position is the IR Memory's owner. If agent population size is N , then the scale for this metric is in N -ary digits - i.e. the base chosen for the logarithm is $N=20$. The largest value for such a population comes when each agent has a chance of being selected = $1/N = 0.05$. This yields an InitiatorEntropy value of 0.05.

The simulation initialisation process sets the Ego position in each IR Memory row to the owner of that particular IR Memory. This means that at initialisation each agent has the same chance of being selected to initiate the first IR event, 0.05. In the InitiatorEntropy charts (i) we notice that entropy falls from this initial maximum for some values of half life and (q/F) . This implies that by the end of the simulation some agents have more chance than others of being selected to initiate interaction rituals.

$B=E$

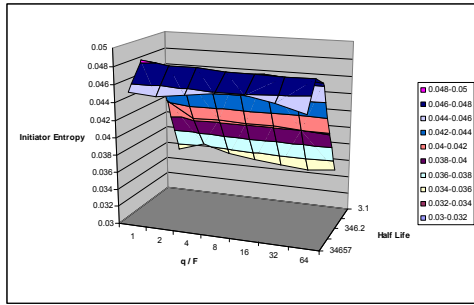

$B=E, C=1$

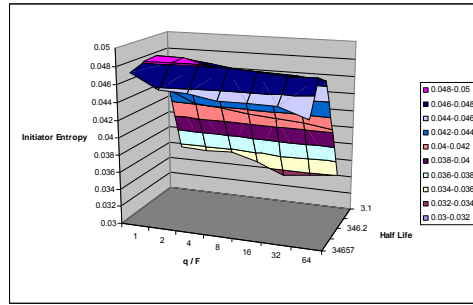

(i) *InitiatorEntropy*

(i) *InitiatorEntropy*

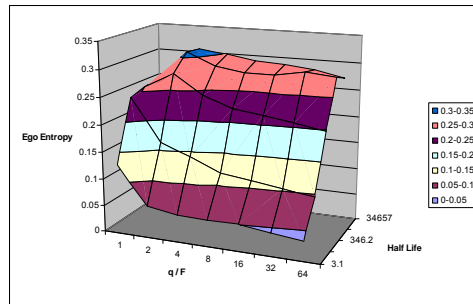
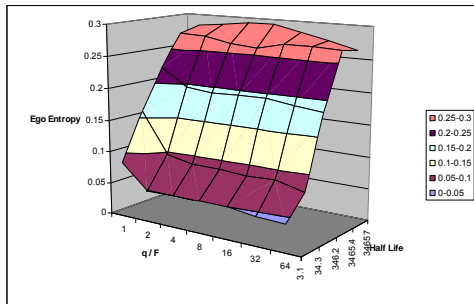

(ii) *EgoEntropy*

(ii) *EgoEntropy*

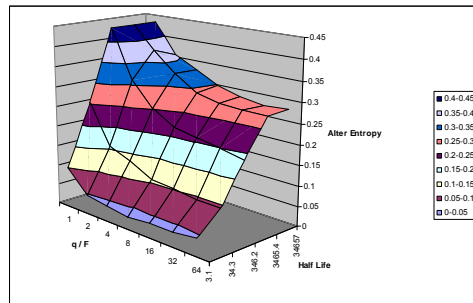
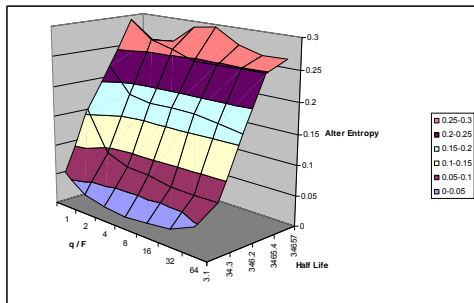

(iii) *AlterEntropy*

(iii) *AlterEntropy*

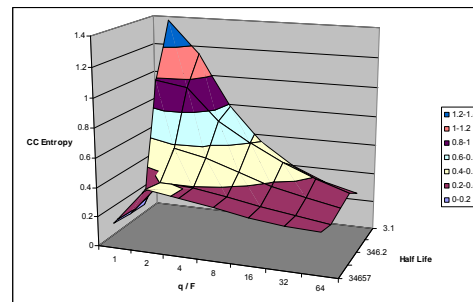
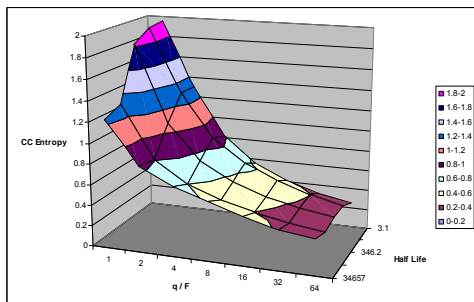

(iv) *CCEntropy*

(iv) *CCEntropy*

Figure 61 Entropy metrics compared for two payoff functions

Ego Entropy

This metric is based on the probability of selecting an agent from the Ego - or initiator - position in IR Memory. (This selection process is theoretical only - no process in the IRAM uses it.) One entropy value is calculated for each agent IR Memory, and then a population mean is output. For units we again use N -ary digits. Given $N=20$ and $m=8$, the maximum value for this is $m * 1/m * \log_N(1/m) = 0.69$ (to 2 decimal places). A peak in the charts of around 0.3 suggests agents have on average 2-3 distinct Ego agents in their IR Memories.

When IR Memory is initialised, the Ego position is set to the agent itself (as mentioned already). This means each agent's IR Memory is homogeneous in the Ego position, and thus its information content is 0. The non-zero values in the charts (ii) show that these memories are no longer homogeneous at the end of the simulation, and it would seem that longer half lives are best for raising this entropy.

Alter Entropy

This metric is based on the probability of selecting an agent from the Alter - or recipient - position in IR Memory. (This selection process is performed from an initiator's IR Memory during the construction of an IR event.) One entropy value is calculated for each agent IR Memory, and then a population mean is output. For units we again use N -ary digits. Given $N=20$ and $m=8$, the maximum value for this is $m * 1/m * \log_N(1/m) = 0.69$ (to 2 decimal places).

When IR Memory is initialised, the Alter position is set to some agent arbitrarily chosen from the population without preference other than excluding the IR Memory owner. This does not guarantee that the m rows of memory will be filled with m distinct agents, but it does mean that initial AlterEntropy is likely to be quite close to its maximum value. From an initial high, interactions allow entropy to drop. We can see from the charts (iii) that long half life prevents this information loss, while moderate half life produces AlterEntropy values close to the highest values seen in the EgoEntropy charts.

CC Entropy

This metric is based on the probability of selecting a cultural trait from a feature position in IR Memory. One entropy value is calculated for each feature, then summed up to give the total Cultural Capital (CC) information content of the agent's IR Memory. Then a population mean is output. Units chosen are q -ary digits, where q is the number of traits, and with m an integer multiple of q it would be possible to have a maximum of $F=2$ q -ary digits from F features. If $m < q$ this maximum will not be achievable, and instead the maximum is $F * m * 1/m * \log_q(1/m)$.

When IR Memory is initialised, each feature is given a value sampled from q traits, with uniformly distributed chances. This does not guarantee that the m rows of memory will be filled with m distinct traits - indeed for $m > q$ this will not be possible anyway.

In the charts (iv) we see that CCEntropy is highest at low q/F and short half life, but falls away with increases in either axis. However, for $q/F = 1$, there is a reverse S-curve shape for scenario B=E as half life increases. We can conclude that it will be easier to obtain an even distribution of traits when $q < m$ than when $m < q$.

10.5.1 Tests on entropy measures

For testing our three claims, we developed a process for performing statistical tests based on three corresponding output metrics (Figure 62). Now that we have four more output metrics we can use an analogous process to compare Energisers (E), Non-energisers (N) and De-energisers (D) for entropy metrics. One modification is required. For tests on InitiatorEntropy, AlterEntropy and CCEntropy we reverse the direction of hypotheses - instead of testing whether E beats N beats D (order: END) we test whether D beats N beats E (order: DNE). We used a confidence level of 95% for all tests, and the numbers of replications are 138 for B=E and 80 for B=E, C=1.

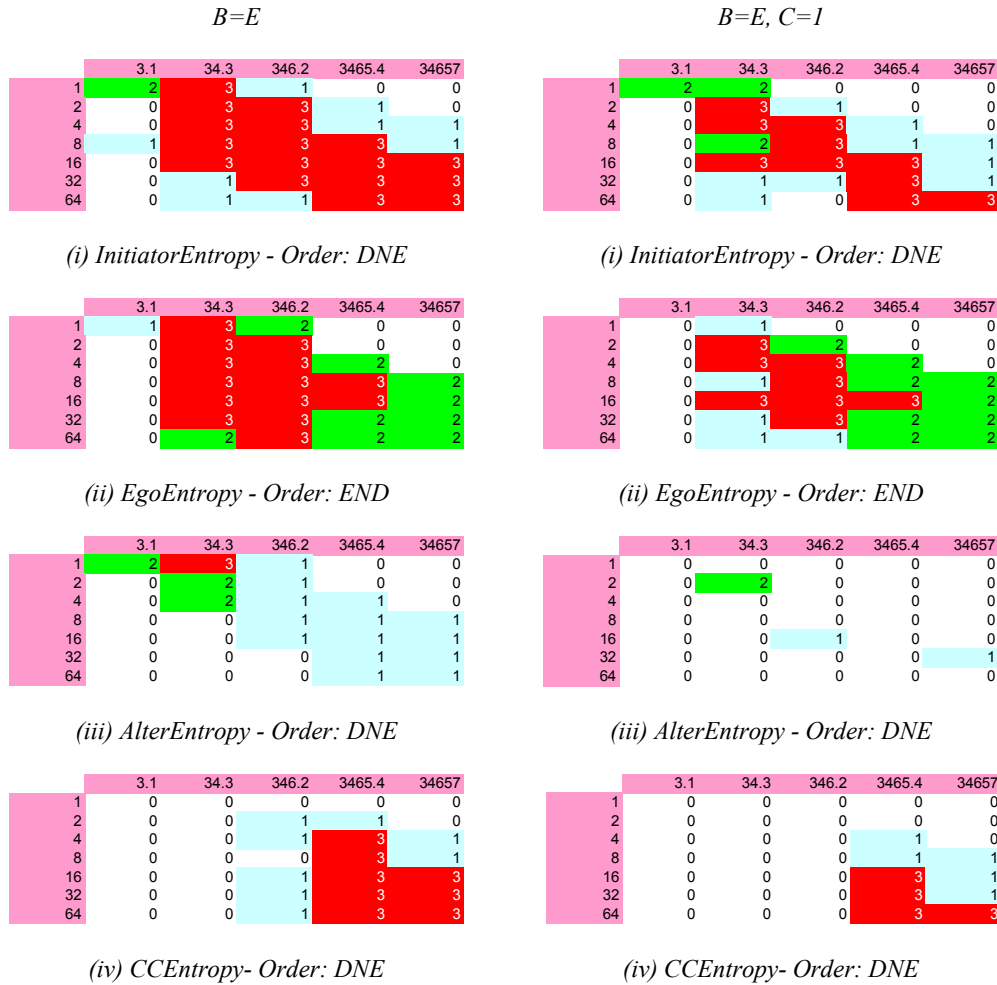

Figure 62 Tests on entropy measures

Initiator Entropy

From the test results (i) there are many parameter combinations at which De-energisers make larger contributions to InitiatorEntropy, and Energisers make smaller contributions. What can we infer from this? If everyone had an equal chance of being selected to initiate, this chance would be $1/N = 0.05$. By considering the relation between probability of being selected and contribution to entropy (*Figure 63*), we can conclude that for De-energisers to make a higher contribution means that they have a higher chance of being selected. (Low values of information content are also obtained

given a probability near to 1 - but it is not possible for the 19 non-energising agents to all have such probabilities at the same time.)

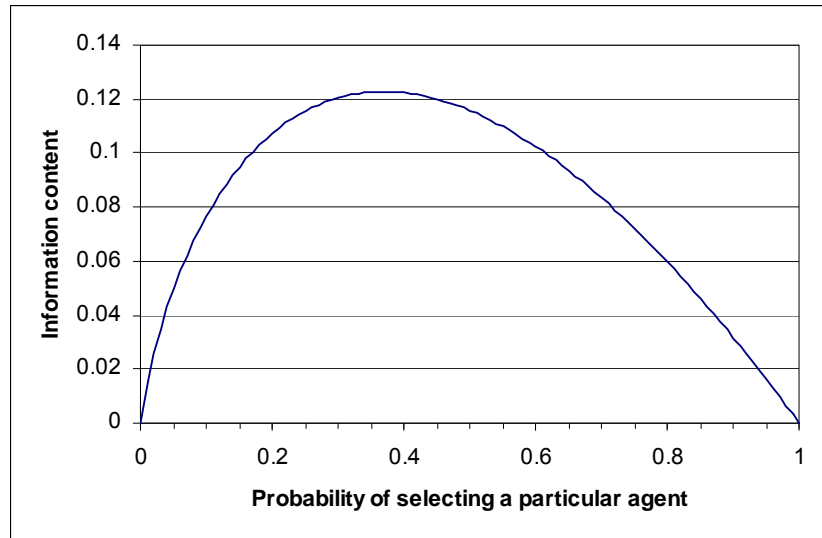

Figure 63 *The information content contributed to InitiatorEntropy by one agent*

The information content contributed to InitiatorEntropy by one agent, as a function of the probability of selecting that agent. Units are N-ary digits.

Other agents are less likely to initiate interactions with De-energisers, because previous such interactions will have yielded lower payoffs, and thus have been less likely to enter IR Memory. The De-energiser is the one agent who does not suffer from this problem, so it would not surprise us if the De-energiser had more rows of IR Memory with itself as Ego, than the 19 others had with themselves as Ego. The probability behind InitiatorEntropy is also based on Expected Gain, but De-energisers may have larger values here as well, since other agents are coming to them with energising interactions less often.

Ego Entropy

From the test results (ii) there are many parameter combinations at which Energisers make larger contributions to EgoEntropy, and De-energisers make smaller contributions. This suggests Energisers' memories contain a more even spread of agents in the initiator role. This is not surprising - from the InitiatorEntropy results we have already been able to infer that De-energisers are more likely to recall themselves as the Initiator, and thus bias their memories.

Alter Entropy

The test results (iii) are less clear cut, but De-energisers probably come out best.

Other agents are less likely to have initiated interactions with them, so De-energisers are likely to be absent from their own Alter-position IR Memory. They are likely to be absent from others' Alter Memory as well, since they de-energise any interactions initiated with them, and de-energising experiences are less likely to be added to memory. But the absence from their own Alter Memory is the more significant, since - other things being equal - they might have been expected to appear there in half the rows on average. This absence means less chance of being sampled as Alter from their own IR Memory, so higher total Alter Entropy overall (see *Figure 64*, especially for probability < 0.5).

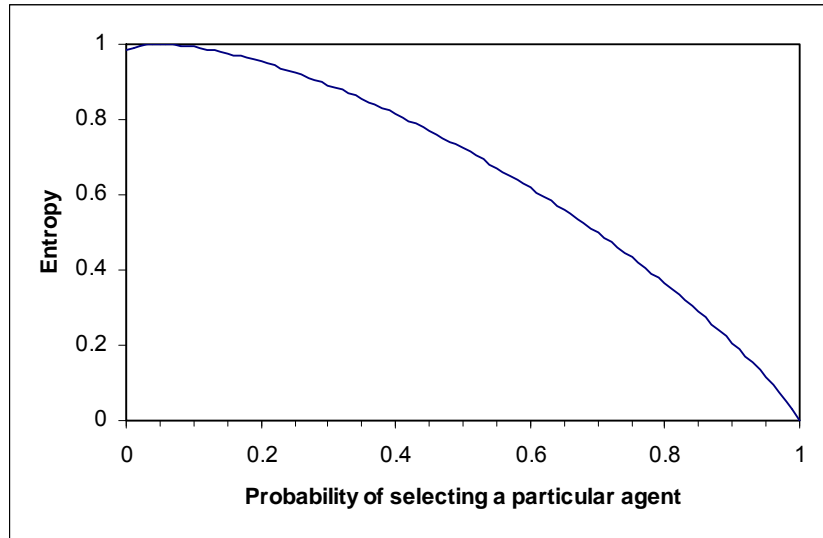

Figure 64 Total entropy given one agent with probability of selection x , and the other 19 agents with even probability

Units are N -ary digits.

CC Entropy

At long half life and moderate to high q/F De-energisers make larger contributions to CCEntropy, and Energisers make smaller contributions. So Energisers have more *boring* cultural capital - there is less uncertainty contained in their recall. On the other hand, they have a more coherent set of experiences - not surprising given that they encourage repeat interactions with them, so there is more opportunity for ideas to be shared between them and their interaction partners. (This is in line with claim 1.) De-energisers are surrounded by more variety and less cultural agreement. They may attempt to initiate more interactions (as inferred from InitiatorEntropy), but they are less likely to succeed. We might expect lots of social activity from them, but little that is constructive.

10.5.2 Further research from the entropy metrics

We conclude these reflections on the entropy metrics with a few hypotheses for empirical testing.

- De-energisers attempt to initiate more interactions.
- De-energisers have a skewed view of the world - a higher proportion of the experiences they remember involve them as the Initiator.
- De-energisers have a less coherent set of experiences to draw upon.
 - So they will find it harder to reach cultural agreement with others. Their contributions are less likely to make sense, or fit the social context.
 - This could perhaps make them a source of novel ideas.
- So De-energisers - agents with de-energising characteristics in their behaviour (body language, form of words etc.) - become de-energisers in another sense - that of generating in others a lower sense of Belongingness.

10.6 Summary for models with multi-item IR Memory

We tested claims 1 and 2 for an IRAM with $m=8$ memory size, and a payoff function based on Belongingness. Scores for claim 1, Frequency of being imitated, were good for nearly all parameter combinations tested – better than the agent-energy and feature-energy models. Scores for claim 2 were poor, though increasing the number of simulation replications from 40 to 138 revealed some positive test results at high

values of (q/F) and moderate to long half life. Scores for claim 3 for an IRAM with payoff function based on Belongingness and Competence, energising affecting Belongingness, were no better than those for earlier models.

Comparing the values of Frequency of being imitated, Size of agent's region and Fitness improvement to those produced by the agent-energy model we saw that the IRAM was very different in its behaviour. To try to understand how the differences emerge for the first two metrics we tested a simplified model with an IR memory, one in which interaction participants were still selected without reference to IR Memories and energy charge. In this IR Model we varied the size of the IR Memory, m . (Table 10 summarises the claims test results.) At shorter half lives, there existed values of m where the Frequency of being imitated peaked. However, as m increased the Size of agent's region showed two different states, one of them involving large region size at a few isolated parameter combinations. This sensitivity to parameter settings, we suggest, should make one cautious before applying the results of a bounded-memory-size model like the IRAM.

Table 10 Approximate parameter ranges where claims tests held (IRAM and IR Memory model)

Model	Payoff Function	Claim 1 (C.L. = 95%)	Claim 2 (C.L. = 80%)	Claim 3 (C.L. = 80%)
IRM $m=1$ to 8	B=E	Most areas but not: Low HL & High q/F ; High HL & $q/F=1$	Some cases where Energisers beat 19 only at high HL.	

IRAM <i>m</i> =8	B=E	Almost every combination. Exceptions at $q/F=1$	$HL \geq 3465$ $q/F \geq 32$	
	B=E, C=1	Most combinations. Exceptions at $q/F=1$ and $HL=3.1$	Energisers beat 19 only at $HL=3645$ & $q/F=64$.	De-energisers beaten at $q/F=64$ with $HL=34$ and $HL=34657$

Finally, we introduced a new set of output metrics based on entropy measures for the multi-row IR Memory in the IRAM. In theory these could tell us something about the information content of agent's memories, or the level of uncertainty in their sampling-based interaction behaviour. We were able to derive from experimental results some empirical hypotheses about energisers and de-energisers that – whatever one may think about our model's validity – would be worth pursuing anyway in future research.

Chapter 11 Mavericks and Boundary Spanners

11.1 Introduction

In section 1.3 we cited studies that described the role communities of practice play in motivating and training their members, but also potentially hindering the take up of new ideas when those ideas must cross the cultural boundaries that exist between communities. The Axelrod Cultural Model illustrates how groups can form defined by cultural homogeneity which then resist infection by novel ideas. An outsider trying to interact with this group will find they have little or no commonality, and so no cultural basis for successful interaction. In Chapter 2 we examined concepts of “energy”, including that in Collins’s theory of interaction rituals. Collins offers a theoretical explanation of why culture is so important to group formation. Agents seek the emotional energy that comes from agents focussing on common cultural objects and practices that then become symbols for the group. This energy is experienced as a feeling of belongingness or group solidarity. Alternative ideas or practices lack any emotional significance for the members of a group, and Fiol & O’Connor (2002) note that trying to introduce novel ideas can trigger an emotional response as the group protects its solidarity. In Chapter 6 we have described the design of a set of simulation models that incorporate such a concept of energy. In this section we describe a set of experiments with the models to illustrate how energy presents a barrier to cultural transmission in addition to that represented in the ACM.

Social interactions with the culturally similar are typically more energising than those with the dissimilar. If an agent is surrounded by opportunities for interaction with the similar, that agent has a good source of energy charge. For a novel idea to be accepted by that agent, it must be sufficiently charged up in interaction to beat the emotional attachment to the agent's current cultural capital. This attachment decays over time, but given plenty of opportunity for interactions with the similar there may be too little chance of the group's symbols losing sufficient charge to be beaten. If a member of a community is happy with what they have, why would they want to adopt an outsider's practices? Unlike the boundaries between cultural regions in the ACM, where agents lacked a trait in common, a boundary based on energy may exist between agents who do have traits in common – just not enough to generate sufficient energy charge to beat that on the traits where they differ. As in Repenning's System Dynamics model of innovation implementation (2002) there is a "motivation threshold" to be crossed if innovations are to diffuse within a social group.

These experiments compare the strength of these energy boundaries given different decay rates to the appeal of superior ideas and to the effects of having the characteristics of an energiser or de-energiser.

11.2 The Maverick Scenario

In the Maverick Scenario (*Figure 65*), a single agent ("the Maverick") enters with cultural capital that is partially distinct to that held by an otherwise homogeneous population. He or she represents a "champion" (Schon, 1963) for a new product or practice. The other agents have a moderately fit set of cultural capital, but without a

source of innovation they cannot switch to a fitter set. Having some overlap with the culture of the Maverick they can, however, interact with it and potentially imitate the Maverick. However, there is also the potential for the Maverick to imitate them, thus losing the novelty, and any agents who do imitate the Maverick may then go on to lose the novelty again through interaction with their neighbours. Under what circumstances can the Maverick disseminate its ideas to the group? Can it disseminate an inferior idea, or only a superior one? How does its success vary with the difference in fitness between competing ideas? How much does it benefit if the Maverick has the characteristics of an energiser? Is there a chance of dissemination if it is a de-energiser relative to the rest of the population? Finally, how do these factors vary in their effects given different energy decay rates?

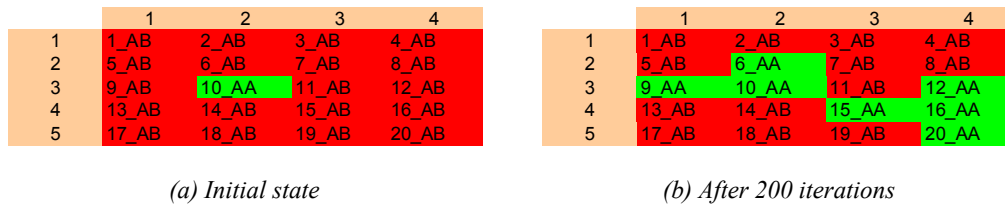
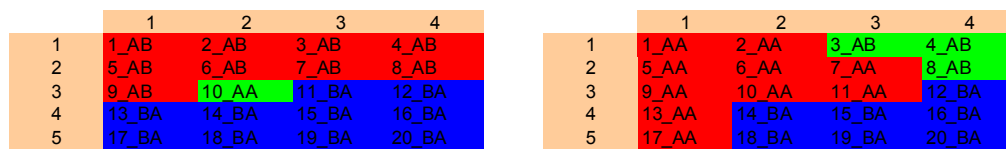

Figure 65 The Maverick Scenario illustrated

One Maverick (shown here as agent #10) resides in a population of 20 agents. Initially (a) the Maverick has cultural capital that differs from that of the other 19 agents in one out of two cultural features – in the case shown it has the best cultural traits of “AA”. (b) shows a population after 200 iterations. To produce this picture we used a 4-neighbour 2D grid network (the experiments below adopt a complete network). The Maverick has succeeded in disseminating its superior idea to some of the other agents.

11.3 The Boundary Spanner Scenario

In the Boundary Spanner Scenario (*Figure 66*) a maverick agent (the “Boundary Spanner”) is confronted with two cultural groups. The groups are arranged such that they lack a common trait and so cannot interact. The Boundary Spanner has traits in common with both – thus it spans the cultural boundary between them and can interact with both communities. The population is set up culturally so that agents in the two groups can reach higher fitness using ideas present in the other group. But to get those they will first need to imitate the Boundary Spanner, thus acquiring the traits needed to have some agreement with the agents in the opposite group. Under what circumstances can the Spanner span the cultural boundary?



(a) Initial state

(b) After 200 iterations

Figure 66 The Boundary Spanner Scenario illustrated

One Boundary Spanner (shown here as agent #10) has superior cultural traits “AA”. Agents 1 to 9 have “AB”. Agents 11 to 20 have “BA”, equivalent in fitness to “AB” but differing in both features, and therefore the agents in these two communities cannot successfully interact at this stage. The Boundary Spanner has one feature in common with each community, and therefore has the potential to spread bridging ideas to both. (b) shows a population after 200 iterations. Again for ease of display we used a 4-neighbour 2D grid network. The Spanner has succeeded in disseminating its superior ideas to agents in both communities with the result that “AA” has become the majority culture.

11.4 The Experiments

In the experiments we run 100 replications for each of six decay rates corresponding to Half Lives in $\{3.1, 34.3, 346.2, 3465.4, 34657, 346573.2\}$, and each of seven energising parameter values in $\{1/6, 1/3, 2/3, 1, 3/2, 3, 6\}$. Agents other than the Maverick / Spanner have energising parameter = 1. Agents have $F = 2$ cultural features, and there are only $q = 2$ cultural traits per feature present in the population. In the Maverick Scenario we gave 19 agents the culture “AB”, and tested Mavericks with culture “AA” (the best) and “BB” (the worst). In the Boundary Spanner Scenario we gave the two groups “AB” and “BA”, and tested Spanners with “AA” and “BB”. “AB” and “BA” are equivalent in fitness value. Three fitness functions were tested, each with a different gap between the “AA” level of 1 and the “AB” / “BA” level, and between the latter and the “BB” level. Our output metric is the number of agents at the end with “AA” as their cultural capital. The numbers shown in the figure are arithmetic means of the simulation replications.

11.5 Results for the Agent-Energy Model

We first examine the scenarios where the Maverick or Boundary Spanner starts with the best cultural traits, “AA” (*Figure 67*).

Maverick starting with “AA”

Energising	Half Life						
	3.1	34.3	346.2	3465.4	34657	346573.2	
1/6	1.2	1.6	20	20	20	20	20
1/3	1	1	0.15	1	1	1	1
2/3	1	0	0	1	1	1	1
1	1.2	0	0	1	1	1	1
3/2	0.2	0	0	1	1	1	1
3	0	0	0	1	1	1	1
6	0	0	0	1	1	1	1

(a.i) Fitness values: (1, 0.875, 0.875, 0.75)

Boundary Spanner starting with “AA”

Energising	Half Life						
	3.1	34.3	346.2	3465.4	34657	346573.2	
1/6	1.6	5.2	20	20	20	20	20
1/3	1.2	3.6	12.2	1	1	1	1
2/3	1.4	2	0	1	1	1	1
1	1	0.4	0	1	1	1	1
3/2	0.8	0.4	0	1	1	1	1
3	0.6	0	0	1	1	1	1
6	0.6	0	0	1	1	1	1

(a.ii) Fitness values: (1, 0.875, 0.875, 0.75)

Energising	Half Life						
	3.1	34.3	346.2	3465.4	34657	346573.2	
1/6	2.4	6	20	20	20	20	20
1/3	2.6	4.2	20	20	20	20	20
2/3	1.6	1.8	0.01	1	1	1	1
1	1.4	0.4	0.06	1	1	1	1
3/2	1.2	0	0.07	1	1	1	1
3	0.2	0	0.05	1	1	1	1
6	0	0	0.05	1	1	1	1

(b.i) Fitness values: (1, 0.75, 0.75, 0.5)

Energising	Half Life						
	3.1	34.3	346.2	3465.4	34657	346573.2	
1/6	1.8	12.8	20	20	20	20	20
1/3	1.6	10	20	20	20	20	20
2/3	1.8	8.4	6.3	1	1	1	1
1	2.2	3.2	0.04	1	1	1	1
3/2	1.2	1	0.03	1	1	1	1
3	1.4	0	0.04	1	1	1	1
6	0.8	0	0.01	1	1	1	1

(b.ii) Fitness values: (1, 0.75, 0.75, 0.5)

Energising	Half Life						
	3.1	34.3	346.2	3465.4	34657	346573.2	
1/6	3.2	13.8	20	20	20	20	20
1/3	2.4	14.2	20	20	20	20	20
2/3	4.6	13.6	20	20	20	20	20
1	2.4	5.8	0.72	1	1	1	1
3/2	3.8	1.2	0.74	1	1	1	1
3	2	0	0.78	1	1	1	1
6	0.2	0	0.74	1	1	1	1

(c.i) Fitness values: (1, 0.625, 0.625, 0.25)

Energising	Half Life						
	3.1	34.3	346.2	3465.4	34657	346573.2	
1/6	4.2	15.6	20	20	20	20	20
1/3	4	15	20	20	20	20	20
2/3	4	16	20	20	20	20	20
1	3.8	11.4	7.55	1	1	1	1
3/2	2.4	4	0.76	1	1	1	1
3	2	0	0.71	1	1	1	1
6	1.8	0	0.74	1	1	1	1

(c.ii) Fitness values: (1, 0.625, 0.625, 0.25)

Figure 67 Results of Maverick and Boundary Spanner Scenarios for the agent-energy model

Shown for each combination of Half Life and Energising Parameter is the number of agents having “AA” as their cultural capital at the end of the simulation run. Three fitness functions are tested (a, b, c) differing in their respective evaluations of moderately fit culture (“AB”, “BA”) and poorly fit culture (“BB”).

The pictures for the Maverick and Boundary Spanner Scenarios are clearly very similar, so we can concentrate on the latter, starting with the fitness values that decrease at the slowest rate. At slow decay rates (long half lives) and most values of the energising parameter the Spanner retains its culture, but cannot spread it to either group (see the bottom right-hand corner in the table). Only the strongest of energisers can overcome the energy barrier – but that is then sufficient to cause the superior ideas to spread throughout the 20-agent population (top right). This picture breaks down at faster decay rates (shorter half lives). A de-energiser cannot get others to take up their ideas, but it can take up ideas from the others, since it has no energy barrier of

its own. So the superior ideas are likely to disappear from the population (bottom left). An energiser can have a higher chance of success at these decay rates, but only manages to spread its ideas in a subset of the simulation replications (top left).

When the gradient of the fitness function is steeper, the Spanner has more chance of getting its ideas across, and at short half lives even mild de-energisers have some chance of doing this. Notice that at some values of the energising parameter (see the individual rows within each table) there exists a half life at which dissemination of the superior ideas peaks (e.g. at half life = 34.3 when energising = 1). For some of the short half lives, there seems to exist an energising parameter value at which output peaks, but these differences were not statistically significant in 100 replications.

When the Maverick starts out with inferior cultural traits (“BB”) the outcomes are less eye-catching. At the steepest fitness gradient, the Maverick’s culture is too inferior and it loses it in every one of 100 replications, at every combination of energising parameter and half life. At the other fitness gradients a small proportion of replications ended in populations homogeneous in their adoption of “BB” – but only at the shortest half life. There were too few of these replications to detect any pattern with respect to the value of the energising parameter for the Maverick. At the longest two half lives in every replication the Maverick retained its ideas at all energising parameter values, but could not disseminate them. In all other cases the Maverick’s ideas were lost, and the population went homogeneous focussed on the majority’s original cultural traits.

Results were similar for a Spanner starting out with inferior traits, but from the variation in final group size for the two rival cultural groups it was apparent that at some of the moderate half lives the Spanner had enabled cultural transfer between the groups for a period of time before the bridge was broken.

In neither the Maverick Scenario nor the Spanner one did an agent with inferior traits at the start produce a population at the end with any agents with the best culture (“AA”).

11.6 Further Models

We next tested the Boundary Spanner Scenario with “AA” culture in the feature-energy model. *Figure 68* compares the results side-by-side with those from the agent-energy model already seen above. For each fitness function there are clearly more parameter combinations at which “AA” spreads throughout the population. There are also few or no cases in which “AA” was lost from the population.

More detailed investigation at the level of individual replications revealed that at short half lives the system converged on one of two types of state: either all agents adopted “AA”, or the Boundary Spanner adopted one of “AB” and “BA” and there was little or no transmission between the two large regions. (The numbers in the figure are, of course, *mean* results from the 100 replications.)

Overall, then, the feature-energy model seems to favour the Boundary Spanner more than the agent-energy model did.

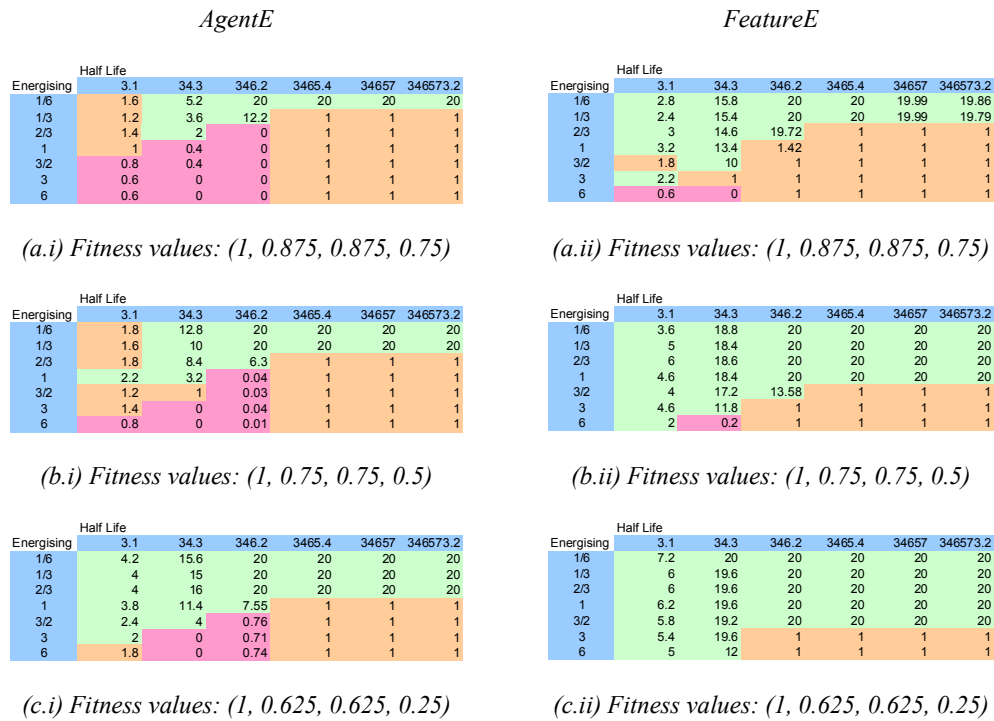

Figure 68 Results of Boundary Spanner Scenarios for a model with AgentE and the feature-energy model

Results of Boundary Spanner Scenarios for a model with AgentE (left, repeated from Figure 67) and the feature-energy model (right). Values of Half Life and Energising Parameter, and the three fitness functions are as before. Output metric is again the number of agents having “AA” as their cultural capital at the end of the simulation run.

We also tested the Boundary Spanner Scenario with “AA” culture in models with IR Memory (Figure 69): first a model with memories containing cultural features, but selecting participants with uniform chances; then the IRAM with memories including also participants, and therefore sampling from that information to select new participants. In both models memory size is set to $m=8$ entries. As the colours suggest, the first IR Model yields similar areas to the agent-energy model, but the magnitude of the figures is different, and not just because of the $m=8$ rows.

IR Model, m=8

	Half Life					
Energising	3.1	34.3	346.2	3465.4	34657	346573.2
1/6	24.0	24.0	24.0	27.0	27.0	27.0
1/3	24.0	24.0	24.0	8.6	8.0	8.0
2/3	24.0	24.0	24.0	7.3	8.0	8.0
1	24.0	24.0	24.0	7.1	8.0	8.0
3/2	24.0	24.0	16.9	7.2	8.0	8.0
3	24.0	24.0	5.1	7.2	8.0	8.0
6	24.0	24.0	5.0	7.3	8.0	8.0

(a.i) Fitness values: (1, 0.875, 0.875, 0.75)

IRAM, m=8

	Half Life					
Energising	3.1	34.3	346.2	3465.4	34657	346573.2
1/6	41.8	42.8	74.4	138.2	141.6	62.5
1/3	41.4	42.4	72.8	132.8	139.7	24.3
2/3	41.2	42.5	73.6	126.3	139.4	14.6
1	41.3	43.1	73.0	122.0	134.9	8.0
3/2	41.3	42.6	73.5	111.8	83.0	8.0
3	41.3	42.7	73.4	26.3	22.9	8.0
6	41.0	43.2	71.4	0.9	0.7	8.0

(a.ii) Fitness values: (1, 0.875, 0.875, 0.75)

	Half Life					
Energising	3.1	34.3	346.2	3465.4	34657	346573.2
1/6	24.0	24.0	24.4	27.0	27.0	27.0
1/3	24.0	24.0	24.6	27.0	27.0	27.0
2/3	24.0	24.0	24.6	8.0	8.0	8.0
1	24.0	24.0	24.7	8.0	8.0	8.0
3/2	24.0	24.0	24.6	8.0	8.0	8.0
3	24.0	24.0	5.9	8.0	8.0	8.0
6	24.0	24.0	5.9	8.0	8.0	8.0

(b.i) Fitness values: (1, 0.75, 0.75, 0.5)

	Half Life					
Energising	3.1	34.3	346.2	3465.4	34657	346573.2
1/6	42.5	47.2	111.3	141.7	141.4	68.2
1/3	42.9	45.7	112.3	142.7	141.9	62.3
2/3	42.5	46.4	105.6	138.0	142.7	16.9
1	42.6	45.2	104.8	133.9	142.2	8.0
3/2	42.3	46.1	103.9	130.1	134.9	8.0
3	42.4	45.5	104.3	76.0	106.6	8.0
6	42.9	46.5	91.1	26.0	3.0	8.0

(b.ii) Fitness values: (1, 0.75, 0.75, 0.5)

	Half Life					
Energising	3.1	34.3	346.2	3465.4	34657	346573.2
1/6	24.0	24.0	25.0	27.0	27.0	27.0
1/3	24.0	24.0	25.0	27.0	27.0	27.0
2/3	24.0	24.0	25.0	27.0	27.0	27.0
1	24.0	24.0	25.0	8.0	8.0	8.0
3/2	24.0	24.0	25.0	8.0	8.0	8.0
3	24.0	24.0	6.0	8.0	8.0	8.0
6	24.0	24.0	6.0	8.0	8.0	8.0

(c.i) Fitness values: (1, 0.625, 0.625, 0.25)

	Half Life					
Energising	3.1	34.3	346.2	3465.4	34657	346573.2
1/6	45.1	54.0	137.9	142.7	143.3	136.1
1/3	44.8	55.3	138.9	143.4	143.5	134.7
2/3	45.2	55.3	137.8	143.9	143.9	135.1
1	44.6	56.4	133.6	140.1	142.0	133.8
3/2	44.5	55.9	133.0	138.0	138.9	8.0
3	45.0	54.1	131.8	131.4	135.0	8.0
6	45.4	54.3	121.3	74.7	21.4	8.0

(c.ii) Fitness values: (1, 0.625, 0.625, 0.25)

Figure 69 Results of Boundary Spanner Scenarios for a model with IR Memory and the IRAM

Results of Boundary Spanner Scenarios for a model with IR Memory (left, where IR Memory contains cultural features) and the IRAM (right, where IR Memory contains participants and cultural features). In both cases, we use m=8 rows of IR Memory. Values of Half Life and Energising Parameter, and the three fitness functions are as before. Output metric is the number of agents' rows having "AA" as their cultural capital at the end of the simulation run. Hence figures will tend to be m=8 times higher than those in earlier models.

This model is demonstrating the effect of the IR Memory update process whereby a row cannot be replaced with different cultural traits if that row is the one remaining example of a particular culture. Agents in these scenarios were initialised with 8 copies of the same culture. Under the update process their IR Memory can then gain in cultural diversity, but to some extent gains cannot be lost. Hence, examination of the replications at short half lives, where imitation is easiest, revealed that agent 1 was acquiring copies of "AB", "BA" and "BB" which it then could not lose. It is arguable

that this artefact of the particular design of update process serves no useful purpose here. In other respects, however, the experiment shows much qualitative similarity with the earlier models, the main impact of having multiple rows being that the half lives at which imitation fails are longer.

The IRAM results do not show up the same artefact – the update process in this model includes participant information in its decision as to how to preserve a minimal level of cultural diversity. It has parameter combinations that yield populations of mostly “AA”-agents, but at the longest half life the proportion of them is declining. In neither model do we see many parameter combinations yielding populations with no “AA”-agents.

That the results with these three models do not closely match qualitatively those with the agent-energy model suggests we should be a little cautious in drawing conclusions from any of them. More research would be needed to explain why the differences exist, which model we might prefer, and what we might learn from such models for when we consider the diffusion of ideas in real social groups.

11.7 Discussion

The results from the agent-energy and feature-energy models show that having the characteristics of an energiser can help in disseminating novel ideas to a group, but it is only one factor. The novel ideas need to be good – inferior ideas have little or no chance of spreading. You also need to be quick. Energy decay rates, or half lives, were another key factor in our experiments, but real agents are unlikely to be able to

alter these. What they can alter is the frequency of interaction attempts. A higher frequency means less time between interaction events, and so less time for energy levels to have decayed between events. The slow decay rates - and long half lives - at which energisers were able to disseminate good ideas, and de-energisers able to at least hold on to their ideas, correspond to more frequent interaction. With less frequent interaction energisers can still transmit their ideas, but they are more likely to take up others' ideas, and the views of the majority tend to dominate.

Fiol & O'Connor's (2002) strategy for community change becomes easier to understand in the light of these results. When outsiders want to introduce a novel practice to a community, they describe starting a pilot project with a small subset of individuals who are less receptive to the others – perhaps through having superior rank or status. This will avoid the threat of peer pressure overcoming the novelty before it has the chance to spread, as happened in several versions of the Maverick Scenario. Fiol & O'Connor describe the problem of an emotional reaction to the novelty as the old practices that symbolise group solidarity are threatened. Our simulations show that fast interactions, where people do not have time to reflect on and reiterate the old culture, will be most likely to disseminate an idea genuinely better in material terms. As Fiol & O'Connor's model indicates, ideas that do not give new practitioners an enhanced sense of competence will not flourish, however.

Chapter 12 Discussion

12.1 Introduction

On the strength of the preceding chapters we would like to propose two contributions:

- Our simulation models are plausible representations of agents with energy. The models are sufficient for generating thoughts about the sociological and psychological concepts in the literature, though they have raised some problems as well.
- Energisers achieve greater take up of their ideas by enhancing emotional energy charges from interaction rituals - as described in the literature - and this only works for particular ranges of energy decay rate / half life and cultural complexity.

We were not able to demonstrate energisers causing larger cultural groups to form, nor energisers raising the problem-solving performance of the agent population.

In the following sections we summarise the arguments for these contributions, then list some strengths and weaknesses of this thesis, and some suggestions for further research.

12.2 Models of agents with energy

A model of agents with energy was both desirable and novel.

In section 1.2 we noted the interest to Operational Research and Management Science of questions of improving organisational design, structure and performance. The information processing properties of organisations had been studied since the work of the Carnegie School in the 1940s-1960s. We identified three approaches to studying organisations - ethnography, social network analysis and computer simulations - which found groups to play important roles in determining the spread of information. From the ethnographic studies we took the concept of “communities of practice”, within which workers were inducted with the cultural practices of the group - a form of training - but around which cultural boundaries formed preventing innovations from entering. There was confirmation of the importance of groups for innovation take up, or lack of it, in both social network analysts’ work on brokerage and closure, and computer models of network formation. Against this background we cited Cross and Parker’s empirical work on energisers and de-energisers in organisations, and the connection between these and issues of motivation, groups and work performance. We proposed to develop the concept of energy further with a view to explaining the phenomena of groups, culture and innovation take up.

In Chapter 2 we followed references to energy-like concepts in psychology, social psychology and sociology. In psychology we found energy did not appear in isolation: to Thayer’s (1989) “energetic arousal” there was “tense arousal”; to “Positive Affect” there was “Negative Affect” (Watson et al, 1988). In addition, there were subjective

states, measurable by self-report, and energy as a correlate of activity, something measurable by objective observation. The latter pointed to a concept of motivation, but social psychologists Ryan and Deci (2000) identified a distinction between intrinsic and extrinsic motivation. Thus the literatures were more complicated than Cross and Parker's concept of "energising" initially suggested. The sources of intrinsic motivation - actions which enhanced our feelings of autonomy, belongingness or relatedness, and competence - were linked by Quinn (2007) to sociologist Randall Collins's theory of emotional energy from interaction rituals (Collins, 1981; 1990; 1993; 2004). An emphasis on intrinsic motivation - rather than extrinsic, carrot-and-stick approaches to motivation - has the potential to transform the workplace, while Collins's micro-sociological theory has been given a variety of applications, such as the sociology of intellectuals (Collins, 1998), and of violence (Collins, 2008). So there seemed good value in an attempt to unify and clarify some of these energy-related concepts.

Collins's concept of emotional energy is part of theory relating it to group membership and cultural capital, which looks like a promising avenue to understanding the phenomena of communities of practice and take up of ideas identified in Chapter 1. But we lacked a model based on Collins's theory and capable of covering these phenomena. In Chapter 3 therefore we surveyed models of networks of interactions, the diffusion of ideas, groups and culture, agents, and work performance - all likely to be required in such a model. We could not find a model that combined all of these features, to say nothing of one with energy as well, and therefore we concluded the idea of a model of energy along the lines of Collins's concept represents a gap worthy of being filled.

Baker and Quinn's (2007) working paper describes the use of an agent-based model to develop the theory of energy, so we needed to review this attempt (Chapter 4). We admired its relative clarity as we tried to reproduce the model and experiments. But our output did not match theirs, and drew attention to the fact that their model output - set alongside empirical data from real networks of energising and de-energising relations - was not as empirically validated as it might initially have seemed. We also felt unconvinced by their paper's references to the literature - in particular, their energy concept did not relate to group membership or cultural capital in Collins's theory, and the representations of "information" and performance were too abstract. So if simulation modelling was a good approach to developing our understanding of the theory of energy, Baker and Quinn had not provided an attempt we needed to build on.

This led to a statement of our objectives as:

- To develop the theory of energy and energisers - in particular:
 - To understand better the relation between energy, culture, group formation and social interaction
 - To investigate how energisers influence the take up of ideas, the formation of groups and the performance of work

In Chapter 5 we found plenty of agreement that computer simulations could help with theory development, but from the perspective of Operational Research we identified two paradigms of simulation modelling (Pidd, 2004). The first is more familiar - that

of simulation models as representations of real-world systems, validated by empirical data and used to make empirical predictions. The second takes the form of a “Soft OR”, interpretivist approach - simulation models as “tools for thinking” (Pidd, 1997; Robinson, 2001), facilitating dialogue between theorists and empirical researchers as we seek to clarify and unify their concepts, or reveal tensions between them. In this second approach, *plausibility* - as judged by ourselves and any researchers working in the fields we try to bring together - is more important than empirical *validation*. The second approach seems more appropriate given that much of the literature drawn upon in Chapter 1, Chapter 2 and Chapter 3 was theoretical rather than empirical. The agent-based simulation models described in Chapter 3 made their contributions to knowledge in this second approach, rather than through quantitative data-fitting and forecasting. Compared to discrete-event simulation and system dynamics, agent-based modelling - in the hands of a skilled programmer - also offered more flexibility during model design and the capability for scaling up agent complexity - a point illustrated in reflections on system dynamics models of the ACM and energy (Appendix A). So we advocated the use of agent-based simulation modelling over discrete-event simulation and system dynamics.

In Chapter 6 we described the design of our own family of models of agents with energy. We began by extending Axelrod’s model of cultural influence (Axelrod, 1997a, chapter 7; 1997b), since it included social interactions between agents with cultural attributes, the formation of cultural groups, and the relevance of cultural boundaries to the diffusion of ideas. In addition, its utility had been proven through its being reproduced, explored and extended by other researchers (Castellano et al, 2000;

Klemm et al, 2003a; 2003b; 2003c; 2005; Kennedy, 1998). We presented three types of energy model, each type ascribing energy to something different.

The simplest model, the agent-energy model (*AgentE*), gave each agent an energy level based on an energy charge, or payoff, obtained from a social interaction event. Energy charge decayed over time, and the difference between the charged-up level and the current level determined an agent's expectations for the gain to be had from a new interaction. This expected-gain calculation was used to stratify the sampling processes that formed part of the construction of a new interaction event. Meanwhile energy levels were involved in the process of updating an agent's culture after an interaction, as updates, or imitation, could occur only if the payoff from the interaction surpassed the current energy level. This meant the energy decay rate was an important factor in the energy models.

The second type of model (*FeatureE*) ascribed energy to the agent's cultural features, or attributes. This produced much similarity of behaviour to the agent-energy model, but attempting to explain the differences proved difficult. The third type ascribed energy to memories of the socio-cultural coalitions formed during interaction ritual events. These coalitions could include a combination of cultural objects - represented by the cultural traits focussed on during interaction - but also the participants. The full version of the Interaction Ritual Agents Model (*IRAM*) included this extra information in the rows of its agents' IR Memory. Using these limited subsets of interaction experiences in a heuristic process of constructing new interactions, the agents enjoyed a bounded rationality for a far smaller computational cost than would have been faced

by recording their attitudes to every potential combination of cultural traits and participants.

In all three models we employed the same calculation of energy payoff from interaction, one composed of up to three different sources. “Belongingness” was based on cultural agreement between interaction participants, and placed the models closest to Axelrod’s model. “Autonomy” was based on the extent to which an agent dominated the interaction by presenting its cultural objects first. “Competence” was based on fitness function, a concept familiar to users of optimisation systems. This A, B and C payoff system was derived from Ryan and Deci’s sources of intrinsic motivation, but also gained support from Collins’s discussion of group status, power, and material resources in the determination of emotional energy. Having defined the formulae for energy payoffs, we also defined what it was for an agent to be energising or de-energising compared to other agents.

Thus we have presented a framework for constructing models of agents with energy, based on the work on energy by Cross and Parker, Ryan and Deci, and Collins among others. Our models link energy to social interaction, cultural attributes and group formation. To do this we have gone beyond existing agent-based simulation models, most notably that of Axelrod. We have also incorporated certain modelling techniques from heuristic search algorithms to give our agents a bounded rationality while being able to remember complex associations of interaction partners and cultural objects or practices.

12.3 Experiments on “energisers”

Having constructed our models we conducted some experiments to test these models as representations of Cross and Parker’s concept of “energiser”. In Chapter 7 we derived three claims from their work:

- Claim 1: Energisers are imitated more frequently than non-energisers, and de-energisers are imitated less frequently.
- Claim 2: The expected size of the cultural region an Energiser belongs to is larger than that to which a non-energiser belongs. De-energisers belong to smaller regions.
- Claim 3: Populations / Organisations / Social groups with energisers outperform those with non-energisers, which in turn outperform those with de-energisers.

For claim 2, a “Cultural Region” was defined to provide compatibility with the experiments on Axelrod’s Cultural Model - namely:

Cultural Region: Two agents are in the same region if and only if they are joined directly or indirectly by an unbroken chain of relations, such that in each relation each agent of the pair has an exact feature-for-feature match in the other’s IR Memory for each row of its own IR Memory.

For several different payoff functions we searched across a range of values of decay rate or half life, and a range of values of the number of traits, q . For claims 1 and 2 we

were searching for a parameter combination at which the situation described in *Figure 70* held, namely: the results for the energiser in the population were above those for the 19 normal agents to a statistically significant degree, while those for the de-energiser were below those for the 19. For claim 3 comparisons were made between populations: results for populations containing an energiser were compared with those for populations with no energiser or de-energiser, and with those for populations with a de-energiser. The findings are summarised in Table 11.

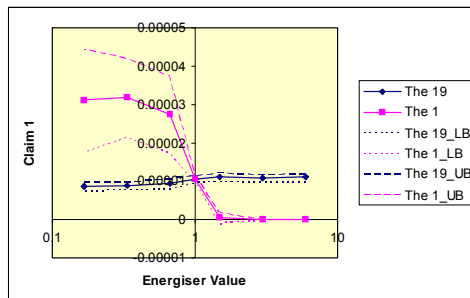

Figure 70 Comparing the 1 energiser/de-energiser with the other 19 agents

Values on the x-axis below 1 (left of the axis) produce an energiser; those above 1 (right) produce a de-energiser. 97.5% confidence intervals are shown around their respective means, giving us at least 95% confidence at each point on the x-axis. When the two sets of intervals do not overlap, a t test is passed. There are six in total.

Table 11 Approximate parameter ranges where claims tests held

Model	Payoff Function	Claim 1 (C.L. 95%)	Claim 2 (C.L. 80%)	Claim 3 (C.L. 80%)
AgentE	B=E	$HL \geq 346$ $1 \leq q/F \leq 16$	Energisers beat 19 at (HL = 3465.4, q/F = 2).	

	B=E, A=1	HL \geq 346 $1 \leq q/F \leq 16$	None	
	B=E, C=1	HL \geq 346 $2 \leq q/F \leq 4$	None	None
	A=E	None	None	
	A=E, B=1	None	None	
	C=E	None	None	None
	C=E, B=1	HL \geq 346 $1 \leq q/F \leq 8$	None	None
FeatureE	B=E	HL = 346 $2 \leq q/F \leq 4$	None	
	B=E, C=1	None score 2 or 3	None	None
	C=E	None	None	None
	C=E, B=1	None	None	None
IRM <i>m</i> =1 to 8	B=E	Most areas but not: Low HL & High <i>q/F</i> ; High HL & <i>q/F</i> =1	Some cases where Energisers beat 19 only at high HL.	
IRAM <i>m</i> =8	B=E	Almost every combination. Exceptions at <i>q/F</i> =1	HL \geq 3465 <i>q/F</i> \geq 32	

	B=E, C=1	Most combinations. Exceptions at $q/F=1$ and HL=3.1	Energisers beat 19 only at HL=3645 & $q/F=64$.	De-energisers beaten at $q/F=64$ with HL=34 and HL=34657
--	----------	-----------------------------------------------------------	----------------------------------------------------------	----------------------------------------------------------------------

Basing energising on the “Autonomy” payoff component produced no positive results for the agent-energy model, and we concentrated instead on the other components. For these, claim 1 (Frequency of being imitated) held at many parameter combinations in all models. But this success did not carry over to claims 2 (Size of agent’s region) and 3 (Fitness improvement performance).

These tests were based on 6 t tests conducted for each value of the energising parameter (*Figure 70*). Multiple simulation replications were run for each parameter combination; though in some cases we limited ourselves to just 20 replications. More replications might have produced more reliable results, but would have taken more processing time. Faced with the desire to test several models with several payoff functions we decided to prioritise searching broadly for interesting results. The appearance of consecutive parameter combinations with similar test results strengthens our confidence in them, and we are happy to conclude that there exist parameter settings at which our models endorse claim 1, while generating no evidence for claims 2 and 3 at any settings.

Comparisons between the models’ behaviours were attempted, but proved difficult. The most complicated models - those with Interaction Ritual Memories - were

particularly hard to explain. This might discourage people from using them, but it should be recalled that one reason for employing simulation models is that they represent situations too complex for analytical reasoning. Emergent or surprising macro-level behaviour is often observed in agent-based models, as exemplified by some of those surveyed in Chapter 3. On the other hand, the behaviour of the IR Memory models as we increased the memory size, m , suggested the presence of artefacts - model phenomena that were products more of our modelling decisions than of some represented theoretical structure. This suspicion was borne out when in Chapter 11 we compared models that included participants in IR Memory (IRAM) with those that excluded them (IRM). Their respective ways of updating IR Memories were causing differences in output. Multi-row models seem worth pursuing, however, for the entropy-based metrics in 10.5 suggested some new hypotheses for testing about energisers and de-energisers:

- De-energisers attempt to initiate more interactions.
- De-energisers have a skewed view of the world - a higher proportion of the experiences they remember involve them as initiating interactions.
- De-energisers have a less coherent set of experiences to draw upon.
 - So they will find it harder to reach cultural agreement with others. Their contributions are less likely to make sense, or fit the social context.
 - This could perhaps make them a source of novel ideas - a forgotten maverick.

- So De-energisers - agents with de-energising characteristics in their behaviour (body language, form of words etc.) - become de-energisers in another sense - that of generating in others a lower sense of Belongingness.

This last point links the behavioural or personality characteristics - which we held constant for the duration of the experiment - to the effects of matching in the cultural traits that could change as a result of interactions. It would be interesting to examine further this interdependence between more and less permanent behavioural traits.

In Chapter 11 we extended our study of the take up of ideas by modelling scenarios in which a single agent - an energiser or de-energiser - was responsible either for disseminating novel ideas to the rest of an otherwise homogeneous population (“Maverick” scenario), or for bridging the cultural boundary between two homogeneous groups (“Boundary Spanner” scenario). Potentially the others’ ideas could travel in the opposite direction, and their sheer weight of numbers meant that the Maverick / Boundary Spanner had no chance when its novel idea was inferior in fitness terms to those in the rest of the population. When its idea was superior, a moderate-to-strong de-energiser destroyed any chance of it spreading - it reduced interaction partners’ energy payoff too much for them to remember the idea. Energisers’ ideas did survive and spread - but not at short half life and fast decay. When charge decays quickly, it becomes easier to update cultural features. The one agent is more likely to update its cultural features with the ideas of the 19 before any of the 19 has adopted the idea of the one. If energy has decayed a lot between interactions then either decay rate is high or interaction frequency is low. Given that energy half life can thus be reinterpreted as representing the inverse of interaction

rate, we propose that the benefits of being an energiser are dependent on the interaction rate in an organisation. From our abstract model we cannot infer how slow an interaction rate has to be to remove the real-world energiser effects observed by Cross and Parker, but we can suggest it as a path for future empirical research.

It might be argued that the fact that energisers are imitated more often should come as no surprise to anyone who has understood the workings of our models. By design energisers raise payoffs, and payoff levels must be higher than decayed energy levels for imitation to occur. To this argument we can point out that there exist some parameter combinations at which this causal chain failed, both in the test of claim 1 and in the Maverick and Boundary Spanner experiments. In addition, energising payoffs through the Autonomy component satisfied claim 1 for no parameter combinations at all. For energisers to beat other agents there must be opportunities provided by their environment, and this depends on decay rates and the rates at which interactions occur for an agent where only the first cultural feature comparison results in a match. At fast decay, or short half life, payoffs beat memory charges without the aid of energising boosts. At high values of (q/F) , first-match opportunities for imitation come so rarely that again extra energising is not needed. At low (q/F) , however, payoffs of 1 occur too frequently (from double-matches in the case of Belongingness payoffs; from “AA” culture in the case of Competence payoffs) for energisers to have anything to beat. Thus energisers can achieve their effects only in a sweet spot.

12.4 Strengths and Limitations

Some of the main strengths of our models and experiments are summarised in Table 12. In each case we have been able to identify at least one related limitation to them as well.

Table 12 Strengths and limitations of the models and experiments

Strength	Weakness
<p>Energy-like concepts from the literature unified in one family of models with culture, group formation and fitness. Cover more items than the Baker-Quinn Model.</p>	<p>Internal model behaviour is hard to understand.</p>
<p>We model energy in relation to decay, the charge on cultural capital, and the take up of new ideas.</p>	<p>But we do not relate it to creativity.</p>
<p>We model groups.</p>	<p>But group dynamics is one-way - formation of cultural regions which then persist continually, as in the Axelrod Cultural Model. These groups never split. “Cultural Region” is a relatively strong definition of group. Real groups have weaker membership criteria, making it possible to belong to several simultaneously.</p>
<p>We model culture.</p>	<p>But in a very abstract sense. Apart from the crude fitness function, there is no</p>

	attempt to give cultural traits an interpretation other than producing social agreement.
A fitness function gives us definitions of “Competence” and problem-solving performance.	The fitness function chosen is poor - energisers had too little chance to affect performance, and claim 3 was not upheld. Unlike in some models of organisational problem solving, our agents have no tasks, and no perception.
Highly flexible family of models, with many variations.	Factor space is too big to be explored reliably.
We covered lots of variations during our experiments.	But far, far more remain untried.
Our boundedly rational agents plan their actions using bounded memory with data on local interactions.	But other methods exist for sampling from and updating these memories and their use may produce different results.
We found metrics based on entropy measures were useful for generating new empirical hypotheses about energisers and de-energisers from the IRAM.	We know of no other models using such metrics, so attempts to interpret them are more tentative.
The model included a variety of visual displays to aid understanding of its workings - as discussed in section 7.5.	Understanding was still difficult and the displays are not always appropriate for understanding the interplay of several stochastic processes. (Hence they do not feature from Chapter 8 onwards.)

<p>Greater reliability in conclusions was obtained through running multiple replications. Statistical tests were also employed.</p>	<p>We were unable to employ formal methods for deciding on a sufficient number of replications. We were also unable to display the impact of each extra replication on confidence intervals (for reasons internal to Microsoft Excel's pivot table calculations).</p>
-------------------------------------------------------------------------------------------------------------------------------------	-----------------------------------------------------------------------------------------------------------------------------------------------------------------------------------------------------------------------------------------------------------------------

12.5 Avenues for further research

12.5.1 Further factors

One source of strengths and limitations of particular interest to simulation modellers in general is the experimental factors provided by the models.

The following factors were varied during at least some of the experiments:

- Decay rate (Half Life)
- # Cultural traits (q)
- IR Memory size (m)
- The energising / de-energising parameter value
- The energy payoff calculation method, including which component energising affected: Autonomy, Belongingness, Competence, or some combination of these.

The following factors were held constant during experiments but could have been varied:

- # Cultural features (F)
- # Agents (N)
- # Participants
- The proportion of the population who are energisers / de-energisers
- Network architecture (Complete, 2-D Grid, Small World etc.)
- Innovation rate (Noise / “Cultural Drift” / Mutation)
- Alternative sampling methods for participants and cultural objects
- Self Stimulus (Possibility of interacting with self)
- Sensitivity to environment when sampling (Perception)
- Alternative fitness functions (Competence calculation)
- Alternative methods for IR Memory updating
- The interaction process

In fact, it is comparatively easy to think up more and more experimental factors. An attraction of agent-based modelling over discrete-event simulation and system dynamics is the ease with which factors such as behaviour rules and network architectures can be added. But for experimentation we soon end up with a factor space beyond the capabilities of our computing to explore. For using a model in persuading others, or facilitating discussions between multiple parties, as suggested in Chapter 5, we face a dilemma. Too many factors and we shall be unable to explore them all, and lose our audience’s attention while we detail each factor combination. Too few, however, and our audience may demand factors be added for the sake of more “realism” or greater robustness of conclusions. For reasons of computer time it

is advantageous to start simple, then add complexity according to demand. For reasons of ease of programming, however, a good programmer needs half an eye on the potential for future extensions of the model during development. As we noted in 6.2, the Axelrod Cultural Model (ACM) worked particularly well in this regard. It was simple in concept, appealing in the issues it addressed, employed relatively few parameters, and was quick to produce in a visually engaging form, yet inspired plenty of replications and extensions by other researchers. Whether our energy extensions of the ACM will retain the same appeal and inspire further research remains to be seen.

We would suggest, however, that a few model factors stand out for future researchers:

The fitness / Competence calculation. Claim 3 was not upheld during our experiments - perhaps because of the choice of fitness function. A decision to represent problem-solving in a specific organisational scenario might lead to the development of a better fitness function, one for which it was easier to see why claim 3 has so far failed.

Sampling methods. We sampled participants and from IR Memories using sampling stratified by expected gain. We could have just taken one of the items with the highest value instead, or stratified using ranks. We could also have stratified by current energy levels, or by original payoffs.

Updating methods. We updated IR Memories when payoffs met current, decayed energy levels. We could have made this process probabilistic. We also found in the multi-row IRAM that agents suffered a loss of cultural diversity in their IR Memories

if we did not restrict row replacement using some kind of like-replaces-like rule. This has the appearance of a kludge, though. It is worth asking how best to maintain a diverse set of memories for the purpose of planning interaction rituals in a model in which homophily and imitation are important components.

The interaction process itself. We focussed on modelling interaction rituals as a kind of matching game. Pujol et al (2005) give their agents memories akin to those in the IRAM but base interactions on a Prisoner's Dilemma game, and justify the model with recourse to social exchange theory in place of our use of interaction ritual theory. The concepts of decay and expected gain can be reapplied to other types of game payoffs.

12.5.2 Docking with other models

The energy models may bear comparison with some sociologically interesting agent-based models. Relating a model to previous models increases confidence in both and promotes understanding of why they behave as they do. We relied on this tactic in Chapter 6 and 8.2 when we designed the energy models as extensions of the Axelrod Cultural Model (ACM), and showed the s-curve behaviour of the latter to be a fast-decay special case of the agent-energy model.

Comparing the IRAM to Pujol et al's model would be another example. They obtained emergent global network architectures - including scale-free ones - from local interactions between agents with limited interaction memories and no awareness of global properties such as the distribution of network links. It would be interesting

to see if the same range of architectures can be obtained through replacing their Prisoner's-Dilemma-based interactions with a matching game. In place of their experimental factors - the costs and benefits of games - we can try to control the emergent network architecture through our cultural parameters (q , F) and energy-related parameters - especially decay rate.

A model of technological evolution - Arthur & Polak's (2006) toolkit approach to problem solving bears some resemblance to the IR Memory, and may offer some justification for updating processes that preserve cultural diversity within the agent's memory.

Centola & Macy's (2007) model of Complex Contagions (see 3.3) examined what happened to diffusion processes when each agent required a number of neighbours to share some idea before that agent would adopt it. If neighbours were unlikely to be neighbours of each other - that is, if clustering in the network was low - then contagions were highly restricted, and bridging links between distant communities were unable to allow the spread of valuable innovations (the so-called "weakness of long ties"). In our energy models, novel ideas will not match those of one's neighbours if they have yet to adopt them, and so an innovator will lack an energy payoff from matching - a sense of "Belongingness" in our models. So while initial adoption is much easier than in the Complex-Contagion model, retaining an idea one cannot recharge is hard. From Chapter 11 we know that whether energising characteristics help in the Maverick and Boundary Spanner scenarios depends on the decay rate. We predict similar considerations will apply to scenarios involving bridging links between communities - the so-called "long ties".

12.5.3 Problem solving in the world of *homo sociologicus*

Along with the ACM another source of inspiration for our model design were heuristic search algorithms. We have reflected in detail on these analogies in Appendix F - though as we point out there, we do not expect representations of sociological theories to make for the best combinatorial optimisation systems. Rather our experience with optimisation systems may offer some clues as to what kind of world *homo sociologicus* lives in, if interaction rituals and emotional energy are a satisfactory way of dealing with its problems. As we have acknowledged in this chapter interest in exploring the problem-solving performance of the IRAM and other models is held back by our lack of a good fitness function. In section F.7 we discuss the problem of a benchmark problem type. Given such a benchmark we can then examine the relationships between parameter settings and performance. For example, where are the “optimal” settings for: the trade off between agent IR Memory size and population size; the decay rate; the payoff components; and a cultural mutation rate? In F.8 we conclude with a number of suggestions:

- agent-based models like the IRAM can bridge a gap between theoretical sociology and theories of optimisation systems, complexity and self-organisation;
- several features of the agents in the theories we have drawn upon for our energy models seem suited to solving problems in complex, dynamic environments, where flexible collaboration can be an advantage;

- theories of interaction rituals and energy - with their emphasis on social similarity and agreement rather than exchange and competition - are an acceptable theoretical basis for this research.

So we very much hope that future research will include simulation models of problem solving through social interaction rituals.

12.5.4 Further questions about culture

Like the Axelrod Cultural Model we have models of emergent cultural agreement. The agents of the ACM - and its derivatives - socially construct agreement in cultural attributes from an initially heterogeneous state. But another important topic is how *heterogeneity* can emerge among *homogeneous* agents. Following Axelrod's suggestion of a process of "cultural drift", Klemm et al (2005) investigated the effects of a source of "noise" or mutation on the basic ACM behaviour. One set of questions concerns mutations: when do they occur, and what determines the chances of particular cultural traits emerging? Our energy models have built into them a facility for producing novel cultural traits instead of traits sampled from IR Memories whenever expected gain on the memories is sufficiently poor. (An alternative would be for a disposition to try other ideas whenever energy levels were poor - i.e. whenever interactions based on memories were repeatedly failing to generate payoffs.) We kept this facility switched off for our experiments, but some kind of innovation process should be tested. Klemm et al (2005) found a slow noise rate meant noise dissolved cultural boundaries, leading to greater homogenisation, while a fast rate prevented a population homogenising at all. In energy models we expect

decay rates will again play an important part in deciding whether innovations have a chance of spreading.

But we also suspect the focus on “cultural drift” or noise misses a more important form of diversification. A single cultural feature mutation causes one and only one agent to distinguish itself slightly from a group. A second mutation event is highly likely to affect a different agent, perhaps in a different feature or producing a different trait. So under a mutation process the frequency distribution of cultural traits will show one popular cultural combination of traits - the original group’s culture - and several combinations with just one or two supporters. In real communities what seems more likely is that groups split - one agent adopts a rival cultural position and is accompanied by a number of supporters. What causes groups to split? Or given tendencies in individuals to innovate, what causes others to follow them? Within a group there may be a network of relations such that agents expect to receive their energy from matching particular individuals, and when those individuals differentiate themselves from the group, those dependent on them for energy have a choice between continuing the relation - which now delivers less energy from matching, unless the dependent agent also adopts the cultural innovation - and innovating in their choice of interaction partner. The full IRAM, with its capability for storing network data in agents’ IR Memories, may be a route to modelling such group splits, but the processing time for an experiment increases linearly with memory size, m , and so we focussed on simpler models and low values of m .

12.5.5 Energy, autonomy and self-determination

A preference for agreement, such as that provided through a sense of Belongingness, and a preference for “fitter” ideas, such as that provided by a sense of Competence, are not the only components of motivation. As we saw in 6.6, Collins mentions “power”, while Ryan and Deci mention a sense of autonomy. Our attempts at representing this dimension through the Autonomy payoff produced no interesting results - but then we were testing claims about energisers, not hierarchies. Another method we anticipated during the design phase was to use the IR Memories’ recording of interaction participants as “Initiators” and “Recipients”. Agents with no recollections of having initiated an interaction would be likely to wait passively for someone else to start. Thus they would be dependent on others for energy recharging opportunities, to rely on extrinsic motivations for doing things since they lack the intrinsic motivation that comes with a sense of autonomy. Someone able to initiate interactions with another in such a way that the other felt more like an initiator would be an “energiser” in a sense not related to cultural matching and Belongingness. This promising route to modelling Ryan & Deci’s (2000; 2002) theory of self-determination again requires much more experimentation with the multi-row IRAM and will have to wait for another study.

12.5.6 Energy, attention and stratification

In 2.6 we mentioned some empirical patterns explained by Collins in terms of emotional energy: his “laws of small numbers”. Some roles or positions require individuals to possess more emotional energy than others. This comes from being the focus of attention of others, and from focussing one’s own attention on some target outside the group (at opponents or problems, for instance), but it means only a

minority of individuals can gain the charge needed for these positions - an “energy elite”. These “small numbers” of people appear in Collins’s survey of intellectual positions in the history of philosophy (Collins, 1998, p.81-82), and in his analysis of violence (Collins, 2008, chapter 10). An energy model should be able to explain through reproducing these patterns. (Just as the scale-free network models in chapter 3 were able to demonstrate stratification in the number of links per node.) But as we noted in 2.6, the “energy stars” are not necessarily energisers. We propose then that attention should be paid to the distribution of energy levels among agents in future energy models.

Following Collins’s use of data on kills by German World War II flying aces (Collins, 2008, p.388), consider the charts in *Figure 71* - based on figures listed online (Wikipedia, 2009, “List of World War II aces from Germany”; Bowers & Lednicer, 1999). (a) 20% of the aces are accounting for 50% of the violence. The next 20% account for 50% of the remainder. (b) The frequencies (and thereby the probabilities) of kills per ace are close to power-law distributed - highly successful aces are highly unusual. Can we explain the distribution of violent acts, with reference to Collins’s theory of emotional energy, using energy simulation models?

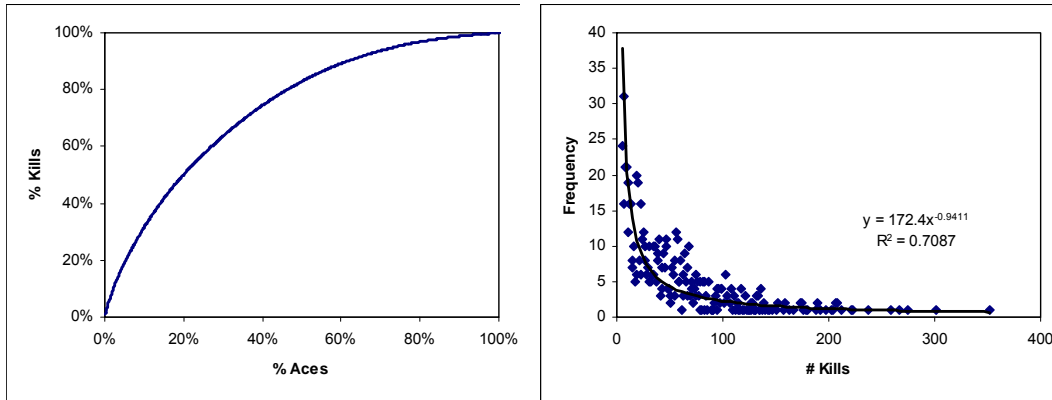

(a) % Kills vs. % Aces

(b) Frequency distribution of number of kills

Figure 71 Data on kills by German World War II flying aces

Source: (Wikipedia, 2009, "List of World War II aces from Germany")

12.5.7 Energy and creativity

“Vigour, energy, vitality: all the great civilisations... have had a weight of energy behind them.”

(Clark, K, 1969, p.4)

Energy is popularly associated with creativity. But what does this consist in? This is not just saying that our most creative producers have the highest energy - a restatement of the stratification patterns described in the previous subsection. Rather the suggestion is that energy is more apparent in a *society or organisation* that produces more. Bruch & Ghoshal (2003) already apply an energy concept to organisations, distinguishing them according to two dimensions (positive vs. negative energy; high vs. low energy intensity) to guide strategic thinking with reference to employees' emotions. Using agent-based models of energy we should also be thinking about energy at levels of organisation above that of the individual agents.

How might energy lead to increased creativity? Partly through increased activity - the more one tries the more chance of an eventual success. But partly also through the kinds of things one tries. Energy is related to “confidence” (Clark, K, 1969) and “expectations” (Collins, 1990). High energy individuals take more risks, and also ignore more constraints. This might explain why following World War II, a period in which many people experienced powerful, shared emotions, there were many surprising innovations in social and political norms and institutions (in Britain the welfare state and the NHS). Without repetition of the common threats and the emotions they caused, such creativity is unlikely. If we can model social living as a constraint satisfaction problem, then energy appears as the analogue of “temperature” in Simulated Annealing.

12.5.8 Summary of further research

Our suggestions for further research then cover more exploration of factors in the existing energy models, closing the gaps between them and other social simulations, relating the problem-solving properties of model social agents to the kind of world human agents live in, and examining more aspects of groups, culture, and energy. It’s good to know we won’t run out of work!

12.6 Concluding remarks

In this chapter we have recapped the motivation for studying energy, and for constructing and experimenting with simulation models of it. We have identified a number of strengths and weaknesses, and this thesis clearly does not represent the final word on how to model energy. Indeed, in our discussion of further research we noted several associations of energy-like concepts that we have yet to address. But we believe our discussion of the models and demonstration of phenomena relating interactions, groups and culture to the take up of ideas justifies continued study of simulation models as tools for thinking about energy from social interactions. We hope readers will feel sufficiently energised to build upon this thesis.

Appendix A System Dynamics models

A.1 Introduction

In 3.4.2 we mention the Axelrod Cultural Model (ACM), an agent-based simulation model of cultural influence (Axelrod, 1997a, chapter 7; 1997b). For reasons given in Chapter 6 we base our simulation models agents with energy on the ACM. In 5.7 we argue for choosing agent-based modelling over other simulation approaches: discrete-event simulation (DES) (Robinson, 2004) and system dynamics (SD) (Sterman, 2000). In this appendix we describe an implementation of the ACM using system dynamics, and discuss the issues it raised. We then speculate on how energy might be added to such a model to produce a system dynamics version of the agent-energy model from Chapter 6 and Chapter 8.

A.2 The Axelrod Cultural Model as stocks and flows

We include here only the essentials of the ACM. A more detailed description of the ACM can be found in the literature and in section 6.2, while its behaviour appears in 8.2 and in Castellano et al (2000), and Klemm et al (2003a; 2003b; 2003c; 2005). Agents have F cultural features - representing dimensions - which may each take one of q cultural traits - represented by a letter. Each iteration, a pair of agents are picked at random, and attempt to interact. Success in interaction depends on whether they have the same trait in the first randomly chosen feature. If so, then a feature is chosen

in which they have different traits (if such a feature exists), and one agent copies (imitates) the trait of the other for that feature. Thus, cultural similarity causes them to interact and imitate, while imitation causes similarity. The simulation is initialised with a population of n agents, each taking arbitrary traits sampled from a uniform distribution. Outputs from the models are based on the notion of a cultural region. Two agents are in the same region if they have the same trait for every feature. Axelrod (1997a, chapter 7; 1997b) showed that the system converges to a static state in which a number of regions have formed: agents within a region have identical traits and can imitate each other no more; agents in distinct regions have no features for which they share traits and so can interact no more. Castellano (2000) showed that the level of cultural homogeneity at convergence - represented by the size of the largest region formed - followed an S-curve with respect to the ratio (q / F): low q/F produced one region incorporating all the population; high q/F produced many regions, each one or two agents in size.

In the system dynamics model we do not represent individual agents. Instead we have a population divided between cultural states - one state for each of the q^F combinations of traits. Figure 72 shows a model for $F=2$, $q=2$, giving us 4 stocks marked "AA", "AB", "BA" and "BB". Obviously, for higher values of q and F the number of stocks in the model becomes too many to comfortably draw. This figure is drawn using *IThink* - a commercial SD package - but we developed our models first in Excel and then in VBA, due to the need to create models of variable levels of cultural complexity using macros. However we restricted ourselves to $F=2$ features.

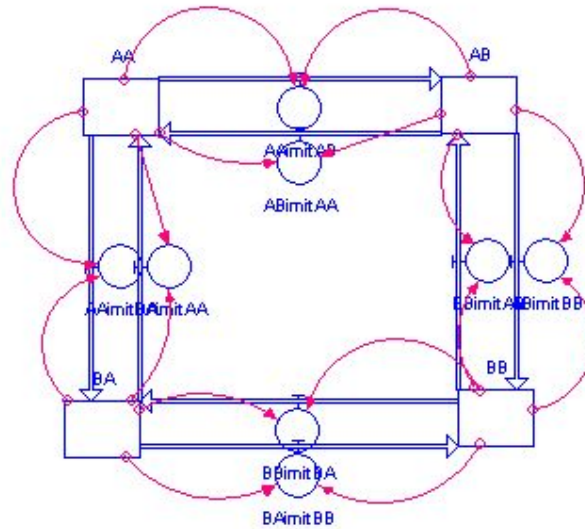

Figure 72 The Axelrod Cultural Model under a system-dynamics approach

There are $F=2$ cultural features and $q=2$ cultural traits, giving $q^F = 4$ possible cultural combinations. Therefore we model the population as 4 stocks, with flows between them representing imitation processes following social interactions. For example, when someone with “AB” culture imitates someone with “AA”, there is flow from AB to AA (“ABimitAA”). The rate of such flow relative to the other flows depends on the stocks of AA and AB people able to meet each other.

Due to imitation events, agents flow from one stock to another. Imitation is obviously not possible between agents with no traits in common, so we only need to consider for each stock the $F * (q-1)$ stocks whose agents are compatible with it. For example, if agents with culture “AB” imitate those with “AA” there is flow from AB to AA. The size of this flow relative to the other flows depends on the sizes of the stocks. We assume random, homogeneous mixing between agents from each pair of neighbouring stocks. This means each flow between communicating stocks is proportional to the product of their respective levels. Obviously, when working with aggregates of agents by cultural type we cannot capture network effects - those differences to ACM behaviour brought about in the agent-based model by arranging agents on 1-

dimensional or 2-dimensional grids instead of allowing anyone to interact with anyone.

A.3 The behaviour of the system dynamics ACM

Initially we also assumed even chances of interactions resulting in ABs imitating AAs, and AAs imitating ABs. This produces a system in equilibrium. For each stock, the flow from a neighbouring stock is equal to the flow out to that stock - even when stocks are initialised with uneven levels.

To get change in stock levels, we had to introduce an asymmetry between inward and outward flows. We did this by introducing a stochastic element. For each pair of stocks we divided the two flows between them not 50:50 but a random amount, drawn from a uniform distribution between 0 and 1. This produces convergence to states familiar from the agent-based models. For example, in Figure 73, a model with $q=2$ converges to leave just two stocks with significant levels, representing two cultural regions. The size of the largest region is represented by the largest stock - approximately 0.8 of the population in this example. Figure 74 shows a model with $q=4$ traits, giving 16 cultural combinations. After 3000 iterations this model is converging on a state with three significant cultural regions.

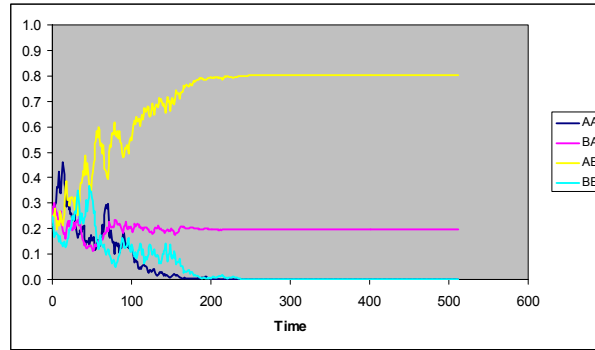

Figure 73 The Axelrod Cultural Model ($q=2$) under a system-dynamics approach, with stochastic imbalance between directions of imitation

There are $F=2$ cultural features and $q=2$ cultural traits, so the population is divided between $q^F = 4$ possible stocks. At equilibrium agents in stocks AA and BB have flowed away into AB and BA. With no AA and BB agents left to interact with, those in AB and BA cannot flow anywhere else. Stock AB represents the largest region, with approximately 0.8 of the population in it.

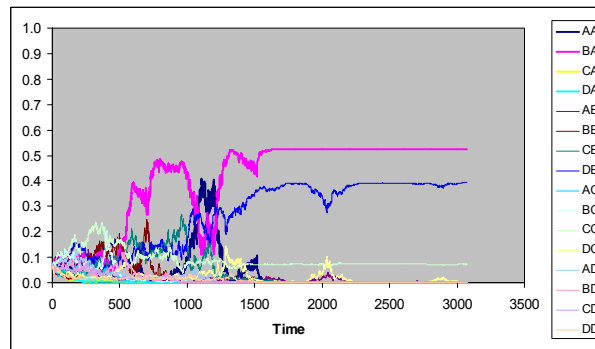

Figure 74 Another SD ACM ($q=4$) with stochastic element

This time with $q=4$ cultural traits, so the population is divided between $q^F = 16$ possible stocks. The three highest stocks after 3000 iterations are BA, DB and CC. Note how the stochastic processes produced a battle between BA and AA around iteration 1000 to 1500, and another battle between DB and DC around iteration 2000.

We tested the system dynamics model against an agent-based version of the ACM. To speed up processing times for the former we ceased performing calculations for stocks that fell below a specified threshold level (intended to be analogous to the situation in

the agent-based models when the number of agents with a particular cultural combination drops to zero). Figure 75 shows the agent-based model (ABM), and system dynamics models with two such threshold levels (SD_1000 and SD_10000, taking threshold levels of 1/1000 and 1/10000 respectively).

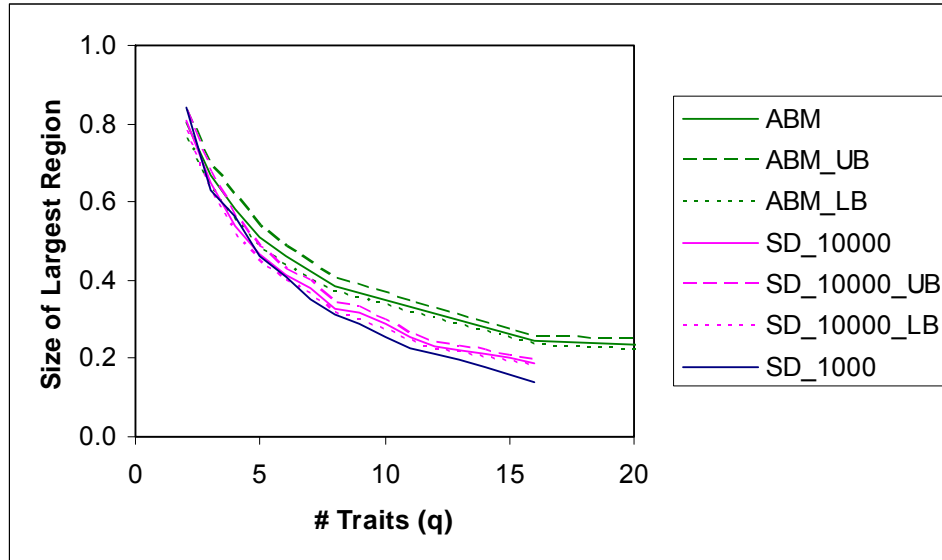

Figure 75 Output from a version of the Axelrod Cultural Model as agent-based model and system dynamics models

Output from a version of the Axelrod Cultural Model as agent-based model (ABM), and system dynamics models with two levels of precision (SD_10000; SD_1000). The size of the largest region is shown for values of q, the number of traits, from 2 to 16, F=2 cultural features. The agent-based model has 20 agents and was run for 100 replications. The system dynamics models contain stochastic elements as well, and so were also run for 100 replications. For ABM and SD_10000 we show 95% confidence intervals.

Both types of simulation model now contain stochastic elements, and so we ran 100 replications, and have shown mean results with 95% confidence intervals for ABM and SD_10000. We can thus be confident in the conclusion that these latter two sets of results are distinct. It would be interesting to know how close we can get the

system dynamics models to an agent-based one. Our introduced stochastic elements were uniformly distributed. But the relative frequency of imitation events “X imitates Y” and “Y imitates X” is unlikely to be so distributed in the agent-based model - there will be less variance. So a better SD approximation to the ACM is certainly possible. Nonetheless, we can conclude that the possibility of imbalances between directions of flow between cultural groups causes the cultural dynamics in the ACM.

The agent-based model contains another source of imbalances in that interaction participants are sampled stochastically. It is conceivable that the frequency of AAs being selected to interact with ABs might differ from the frequency of AAs being selected to interact with BAs, even when there are equal numbers of ABs and BAs to interact with. It would be interesting to know the effects of incorporating this stochastic element in the SD models - both in place of and in addition to the imbalance in directions already introduced.

A.4 Towards a system dynamics agent-energy model

How might an energy model be represented in system dynamics software? Let us take the case of the agent-energy model described in Chapter 6. For each cultural combination we model not only a stock of agents having that culture, but also a stock of energy - the mean level of those agents. Thus we have q^F cultural stocks, and q^F energy stocks.

Energy stocks are subject to decay - a simple negative feedback loop with some specified decay rate. But they also each have a recharging loop. The rate of flow in

this is determined by payoffs from successful interactions - so we might model this as a function partly of the interaction rates between the corresponding cultural stock and its neighbours. But the function will also have to include the rate of agents in that stock interacting with other agents in that stock - which in the agent-energy model yielded a higher payoff than imitation events.

Flows between cultural stocks - i.e. due to imitation events - are determined not just by the interaction rates, but also by the energy levels. If an energy stock level is high, the corresponding cultural stock will not lose contents. Its charged-up member agents do not want to imitate agents from other stocks. If an energy stock is low, there will be no such restriction on flow out of the cultural stock.

At this point, however, a difference emerges between how one would like to model things in system dynamics, and how we have modelled them in the agent-based model. Recharging and imitation in the latter model depend upon thresholds being crossed: if energy charge level is 0.4 when payoff is 0.5, the level is increased to 0.5; if it is 0.6, the level is retained and imitation does not occur. It is hard to envisage aggregate versions of these micro-level (i.e. agent-pair-level) events - indeed a system dynamics specialist (which we are not) might conceive of quite a different relation between energy levels, interactions and recharging flows if he or she started by thinking at an aggregated (cultural-group) level. We invite system dynamicists to take up the challenge!

However they attempt it, we suspect at least one difference in behaviour between the SD ACM and the SD energy model - sensitivity in the latter to initial stock levels.

Cultural stock levels determine recharging rates: given lots of like-minded friends, it is easy to maintain a sense of belonging; given few, one will struggle to recharge, leading to an increase in imitation, or flow out of the cultural stock. It would be interesting to see what effects the tight coupling of cultural with energy stock levels has. We predict that if initial stock levels are uneven, we will not need to add stochastic elements will to produce a converging model.

How might we model energisers within this SD agent-energy model? One way is to assume the agent population is divided into more stocks - not just for cultural combinations but for energisers and non-energisers as well: a total of $2 * q^F$ cultural stocks (with accompanying energy stocks). Adding de-energisers to the model would increase the stocks again. Now it becomes clear why an agent-based modelling approach is preferable to system dynamics! Heterogeneity among the agents means too many stocks to be represented.

A.5 Conclusions regarding system dynamics models

Comparing the system dynamics and agent-based models we conclude:

- When agents are heterogeneous - whether of different cultural types or of variable energising capabilities - system dynamics models become unwieldy in their numbers of stocks and flows. We need macros to generate them, and struggle to display them. Coding and running variable numbers of traits and features, and other agent attributes is comparatively easy in an agent-based

version of the ACM. We can also examine the effects of network structures, such as spatial location, on agent interaction opportunities.

- The levels of ACM cultural stocks converge on a particular degree of cultural diversity because of imbalances between flows in and out. Without an imbalance - such as through some stochastic process - the ACM would be static from initialisation.
- The method of recharging energy levels following an interaction seems specific to the agent-based, micro-level approach. A system dynamics model combining cultural and energy stocks would probably call for a different interpretation of recharging.
- If somebody can implement an SD energy model, the coupling between cultural and energy stocks will probably make for interesting dynamics.

Appendix B Results with the agent-energy model

(AgentE)

B.1 Introduction

We collate in this appendix the results of all experiments performed with the agent-energy model in Chapter 8. The model itself was described in Chapter 6.

Results for eight scenarios are shown (Table 13) - with the first seven scenarios being distinguished by their payoff functions. See chapter 5 for the definitions of the payoff function components, Belongingness, Autonomy and Competence, and the use of the energising parameter. 20 simulation replications were run for each scenario - apart from the first one, “B=E”, for which 40 replications were run.

Table 13 Agent-energy model scenarios explained

Code	Explanation
B=E	Payoffs based on Belongingness. Energising alters Belongingness
B=E, A=1	Payoffs based on Belongingness and Autonomy. Energising alters Belongingness
B=E, C=1	Payoffs based on Belongingness and Competence. Energising alters Belongingness
A=E	Payoffs based on Autonomy. Energising alters Autonomy
A=E, B=1	Payoffs based on Autonomy and Belongingness. Energising alters

	Autonomy
C=E	Payoffs based on Competence. Energising alters Competence
C=E, B=1	Payoffs based on Competence and Belongingness. Energising alters Competence
B=E, N=10	As B=E, but with 10 agents in the population instead of 20

We use here five decay rates $\{0.8, 0.98, 0.998, 0.9998, 0.99998\}$ giving us corresponding half lives $\{3.1, 34.3, 346.2, 3465.4, 34657\}$. We use seven values for number of traits, q , while number of features is held constant at $F=2$, giving us for (q / F) : $\{1, 2, 4, 8, 16, 32, 64, 128\}$.

B.2 Agent-energy behaviour

For each scenario six charts are given, with the data they are based on also given in tables. There are two output metrics: Frequency of being imitated (a), and; Size of agent's region (b). We show for each metric: mean results when all 20 agents are normal or non-energising (energising parameter = 1); difference between an Energiser's results (energising parameter = 1/6) and those of the 19 non-energising agents; difference between the 19 non-energising agents and a De-energiser's results (energising parameter = 6).

B.2.1 Payoff: Belongingness; Energising: Belongingness (B=E)

(a) Frequency of being imitated

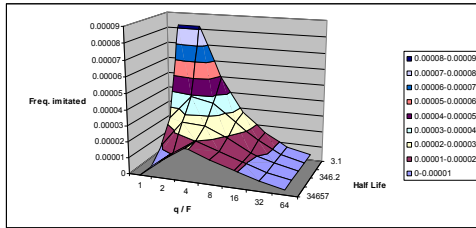

(b) Size of agent's region

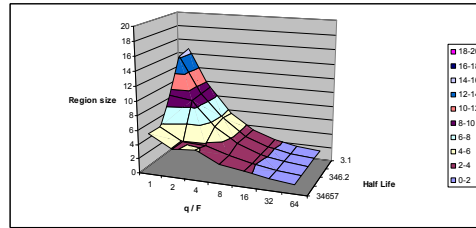

(i) Results with normal agents

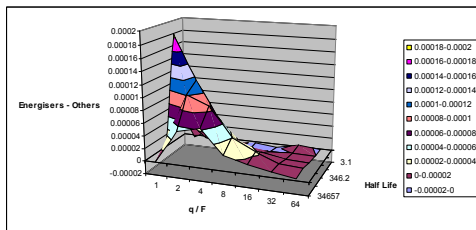

(i) Results with normal agents

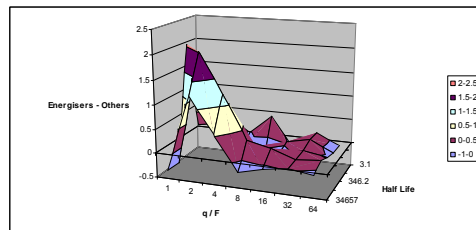

(ii) Energiser (1/6) - others

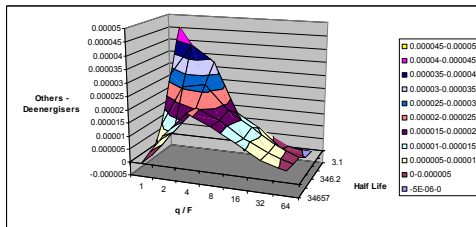

(ii) Energiser (1/6) - others

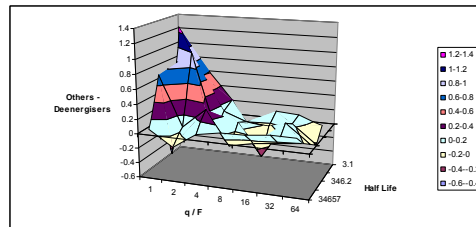

(iii) Others - De-energiser (6)

B=E Frequency of being imitated

All agents set to normal (Energising Parameter = 1)

		Half life				
		3.1	34.3	346.2	3465.4	34657
q / F	1	0.000082	2.36E-05	8.59E-06	1.25E-07	9.38E-08
	2	8.2E-05	0.000039	2.64E-05	1.1E-05	1.14E-05
	4	4.92E-05	3.61E-05	2.55E-05	2E-05	2.06E-05
	8	2.73E-05	2.48E-05	1.92E-05	1.51E-05	1.5E-05
	16	1.53E-05	1.49E-05	1.13E-05	1.07E-05	1.05E-05
	32	7.03E-06	7.13E-06	6.72E-06	5.91E-06	6.44E-06
	64	3.59E-06	3.38E-06	3.19E-06	3.06E-06	2.81E-06

Difference: Energiser (Param. = 1/6) - The Others

		Half life				
		3.1	34.3	346.2	3465.4	34657
1	1	-3.4E-06	3.71E-05	0.000186	1.62E-05	1.25E-06
	2	1.68E-05	1.04E-05	0.000115	0.000101	5.33E-05
	4	-1.3E-05	5.03E-06	5.75E-05	8.62E-05	6.22E-05
	8	-1.7E-06	-4.4E-06	1.71E-05	4.08E-05	2.49E-05
	16	-5.6E-06	-1.6E-06	9.31E-06	2.25E-05	0.000015
	32	2.37E-06	3.29E-06	3.42E-06	8.59E-06	8.32E-06
	64	-1.4E-06	2.3E-07	1.81E-06	6.51E-06	2.86E-06

Difference: The Others - De-energiser (Param. = 6)

		Half life				
		3.1	34.3	346.2	3465.4	34657
1	1	4.51E-05	2.76E-05	9.74E-06	1.64E-07	9.87E-08
	2	3.28E-05	4E-05	2.66E-05	1.06E-05	1.16E-05
	4	1.71E-05	3.39E-05	2.71E-05	2.05E-05	2.1E-05
	8	-3.9E-06	1.48E-05	1.81E-05	1.66E-05	1.7E-05
	16	1.41E-06	9.41E-06	1.23E-05	1.1E-05	1.2E-05
	32	2.3E-07	2.01E-06	6.61E-06	6.55E-06	6.78E-06
	64	-9.2E-07	-2.6E-07	2.8E-06	3.42E-06	4.18E-06

(iii) Others - De-energiser (6)

Size of agent's region

All agents set to normal (Energising Parameter = 1)

		Half life				
		3.1	34.3	346.2	3465.4	34657
1	1	14.6525	14.19	9.2825	5.6725	5.7425
	2	9.16	9	8.865	3.9025	3.9375
	4	5.48	5.71	5.4125	3.7825	4.17
	8	3.3225	3.3625	3.36	2.795	2.695
	16	2.2375	2.165	2.1725	2.0675	2.1775
	32	1.57	1.59	1.6075	1.535	1.5975
	64	1.2775	1.2825	1.295	1.2575	1.24

Difference: Energiser (Param. = 1/6) - The Others

		Half life				
		3.1	34.3	346.2	3465.4	34657
1	1	0.557895	0.197368	2.05	-0.33158	-0.32368
	2	0.3	0.278947	1.047368	2.021053	1.247368
	4	-0.02895	-0.26842	0.352632	1.207895	0.539474
	8	0.389474	-0.42368	0.039474	0.321053	-0.17895
	16	-0.27895	0.023684	-0.06053	0.202632	-0.04737
	32	0.126316	0.128947	0.057895	0.026316	0.023684
	64	-0.09211	-0.10263	-0.02368	0.086842	-0.04211

Difference: The Others - De-energiser (Param. = 6)

		Half life				
		3.1	34.3	346.2	3465.4	34657
1	1	-0.35526	1.278947	-0.47632	0.728947	0.078947
	2	0.571053	0.618421	0.992105	0.052632	-0.12895
	4	0.202632	0.121053	-0.06316	0.323684	0.084211
	8	-0.36053	0	0.089474	-0.14211	0.139474
	16	0.097368	-0.02632	-0.35789	-0.06579	0.144737
	32	0.076316	0.036842	0.144737	-0.02895	0.184211
	64	-0.04737	-0.22105	-0.10789	0.002632	0.178947

B.2.2 Payoff: Autonomy; Energising: Autonomy (A=E)

(a) Frequency of being imitated

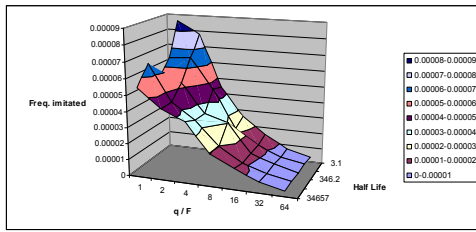

(b) Size of agent's region

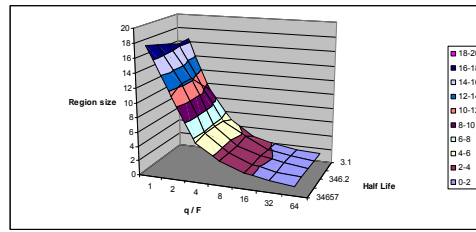

(i) Results with normal agents

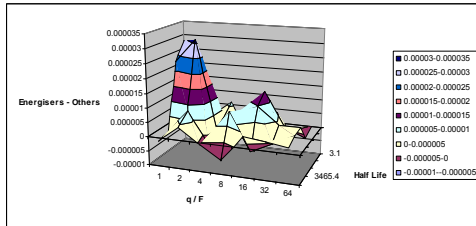

(i) Results with normal agents

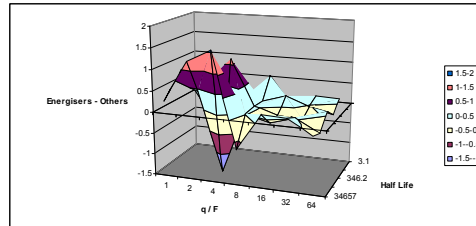

(ii) Energiser (1/6) - others

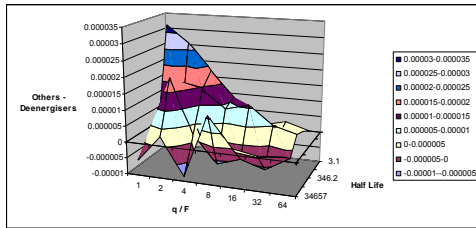

(ii) Energiser (1/6) - others

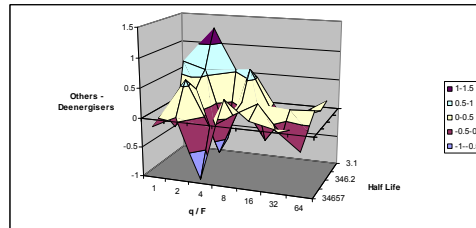

(iii) Others - De-energiser (6)

A=E **Frequency of being imitated**

All agents set to normal (Energising Parameter = 1)

		Half life				
		3.1	34.3	346.2	3465.4	34657
q / F	1	8.59E-05	6.45E-05	5.48E-05	6.67E-05	5.52E-05
	2	7.81E-05	6.54E-05	5.26E-05	4.41E-05	4.41E-05
	4	4.41E-05	4.63E-05	3.46E-05	3.43E-05	3.78E-05
	8	2.59E-05	2.19E-05	3.04E-05	1.98E-05	2.01E-05
	16	1.51E-05	1.26E-05	0.000012	0.000011	1.31E-05
	32	7.13E-06	6.44E-06	7.06E-06	6.25E-06	6.94E-06
	64	3.19E-06	3.94E-06	3.63E-06	3.56E-06	3.38E-06

Difference: Energiser (Param. = 1/6) - The Others

		Half life				
		3.1	34.3	346.2	3465.4	34657
1	1	-2.6E-07	2.93E-05	2.32E-05	-5.9E-07	-1.2E-06
	2	3.95E-07	-1.7E-06	3.13E-05	8.09E-06	4.47E-06
	4	6.12E-06	2.5E-06	4.61E-07	-3E-06	-6.6E-07
	8	-8.3E-06	-5.1E-06	6.71E-06	9.14E-06	-5.1E-06
	16	-8.6E-07	1.31E-05	9.8E-06	-3.8E-06	3.75E-06
	32	-3.8E-06	9.21E-07	3.95E-06	-2E-07	2.89E-06
	64	-1.3E-07	-2.1E-06	4.08E-06	3.36E-06	1.97E-06

Difference: The Others - De-energiser (Param. = 6)

		Half life				
		3.1	34.3	346.2	3465.4	34657
1	1	2.03E-05	3.23E-05	8.55E-07	-2E-07	-5.3E-06
	2	5.79E-06	2.72E-05	3.03E-06	1.91E-05	2.89E-06
	4	5.33E-06	1.88E-05	1.43E-05	1.91E-06	-8.6E-06
	8	1.45E-06	1.09E-05	8.88E-06	-6.3E-06	1.11E-05
	16	4.61E-07	-6.6E-08	1.09E-05	-3.9E-06	2.04E-06
	32	2.11E-06	1.32E-07	5.33E-06	-6.2E-06	5.92E-07
	64	0	1.97E-06	3.22E-06	-1.7E-06	1.38E-06

Size of agent's region

All agents set to normal (Energising Parameter = 1)

		Half life				
		3.1	34.3	346.2	3465.4	34657
1	1	16.415	16.23	16.9	17.325	17.78
	2	9.03	10.615	12.265	12.31	11.415
	4	4.84	5.565	5.705	5.805	5.43
	8	2.595	3.69	3.31	3.37	3.41
	16	1.825	2.095	2.285	2.18	2.185
	32	1.385	1.565	1.7	1.52	1.615
	64	1.21	1.26	1.32	1.35	1.31

Difference: Energiser (Param. = 1/6) - The Others

		Half life				
		3.1	34.3	346.2	3465.4	34657
1	1	0.705263	0.747368	0.621053	0.626316	0.289474
	2	0.3	-0.6	-0.2	0.426316	1.268421
	4	-0.23158	-0.04737	1.115789	-1.44737	1.552632
	8	0.515789	0	0.036842	0.010526	-0.66842
	16	-0.22105	0.194737	-0.12632	-0.15263	0.205263
	32	0.105263	-0.02105	-0.17895	0.036842	0.189474
	64	0.078947	-0.15789	0.078947	-0.26316	-0.15263

Difference: The Others - De-energiser (Param. = 6)

		Half life				
		3.1	34.3	346.2	3465.4	34657
1	1	0.305263	0.710526	-0.37368	-0.00526	-0.12632
	2	1.268421	0.605263	0.347368	0.6	0.068421
	4	0.536842	-0.62105	-0.74211	-0.16842	-0.93158
	8	0.421053	0.663158	0.178947	0.073684	0.452632
	16	-0.2	-0.08421	-0.42632	0.310526	0.136842
	32	-0.13684	-0.10526	0.136842	-0.16316	0.042105
	64	0.110526	0.052632	0.163158	-0.05263	-0.26842

B.2.3 Payoff: Autonomy & Belongingness; Energising: Autonomy (A=E,

B=1)

(a) Frequency of being imitated

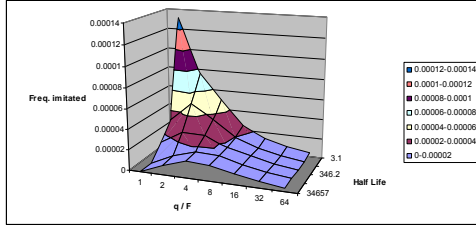

(b) Size of agent's region

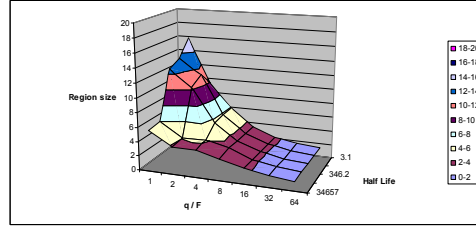

(i) Results with normal agents

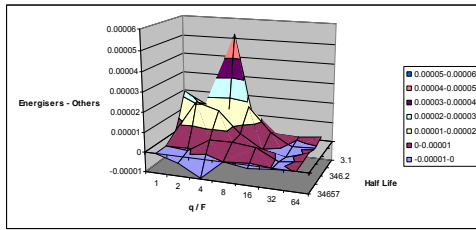

(i) Results with normal agents

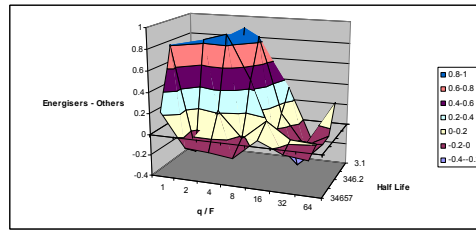

(ii) Energiser (1/6) - others

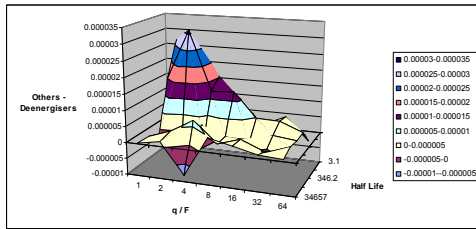

(ii) Energiser (1/6) - others

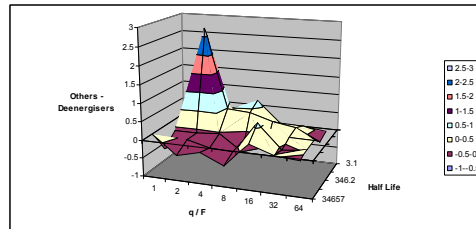

(iii) Others - De-energiser (6)

(iii) Others - De-energiser (6)

A=E,B=1 Frequency of being imitated

		All agents set to normal (Energising Parameter = 1)				
		Half life				
		3.1	34.3	346.2	3465.4	34657
q / F	1	0.000131	3.05E-05	1.43E-05	3.13E-07	6.25E-08
	2	7.54E-05	4.96E-05	2.68E-05	1.08E-05	9.38E-06
	4	4.99E-05	3.57E-05	2.62E-05	1.75E-05	1.61E-05
	8	2.48E-05	1.96E-05	1.67E-05	1.64E-05	1.54E-05
	16	1.43E-05	1.12E-05	1.11E-05	1.03E-05	1.03E-05
	32	8.19E-06	6.69E-06	5.88E-06	6.31E-06	6.38E-06
	64	4.13E-06	3.06E-06	3.38E-06	3.56E-06	3.25E-06

		Difference: Energiser (Param. = 1/6) - The Others				
		Half life				
		3.1	34.3	346.2	3465.4	34657
	1	3.29E-07	2.23E-05	4.74E-06	0	-6.6E-08
	2	-7.1E-06	1.67E-05	2.08E-05	-1.1E-06	-3.6E-06
	4	5.2E-05	2.11E-06	1.74E-05	5.79E-06	-9.5E-06
	8	2.24E-06	1.75E-05	6.45E-06	5.92E-06	0
	16	9.21E-07	5.26E-06	-3.9E-07	4.8E-06	-1.7E-06
	32	5.92E-07	-1.2E-06	-2.6E-06	-8.6E-07	-3.3E-07
	64	1.58E-06	-3.9E-07	9.87E-07	4.61E-07	6.58E-08

		Difference: The Others - De-energiser (Param. = 6)				
		Half life				
		3.1	34.3	346.2	3465.4	34657
	1	2.66E-05	1.51E-05	-1.6E-06	1.32E-07	1.97E-07
	2	1.7E-05	3.13E-05	-7.7E-06	2.57E-06	1.58E-06
	4	1.55E-05	1.2E-05	-4.1E-06	6.78E-06	-8E-06
	8	3.29E-06	1.26E-05	2.63E-07	2.63E-07	4.54E-06
	16	6.58E-07	4.67E-06	-1.3E-06	2.5E-06	2.96E-06
	32	3.95E-06	4.67E-06	2.3E-06	-5.3E-07	9.87E-07
	64	-3.4E-06	1.78E-06	1.51E-06	2.04E-06	5.92E-07

Size of agent's region

		All agents set to normal (Energising Parameter = 1)				
		Half life				
		3.1	34.3	346.2	3465.4	34657
	1	15.785	13.395	12.595	5.985	5.715
	2	9.265	11.315	10.215	4.025	3.825
	4	5.8	5.81	5.535	4.115	3.795
	8	3.335	3.355	3.28	3.415	2.935
	16	2.14	2.16	2.155	2.135	2.185
	32	1.635	1.565	1.515	1.595	1.6
	64	1.35	1.265	1.29	1.33	1.275

		Difference: Energiser (Param. = 1/6) - The Others				
		Half life				
		3.1	34.3	346.2	3465.4	34657
	1	-0.34211	0.284211	0.068421	0.810526	0.226316
	2	-0.19474	0.763158	0.831579	-0.19474	-0.08947
	4	0.889474	-0.06842	0.894737	0.221053	-0.10526
	8	0.189474	0.847368	0.478947	-0.02105	-0.13684
	16	0.315789	0.115789	-0.08421	0.168421	0.057895
	32	-0.17368	-0.18947	-0.3	0.021053	-0.04211
	64	0.210526	-0.06316	-0.06842	0.005263	-0.07368

		Difference: The Others - De-energiser (Param. = 6)				
		Half life				
		3.1	34.3	346.2	3465.4	34657
	1	-0.92632	-0.7	-0.1	-0.42632	0.2
	2	-0.76316	2.726316	-0.09474	-0.07895	-0.31053
	4	-0.14211	0.478947	-0.03158	-0.23158	-0.14737
	8	0.610526	0.447368	-0.47368	-0.27368	-0.42105
	16	0.010526	0.257895	-0.28421	0.584211	0.226316
	32	0.005263	0.152632	0.078947	-0.07368	0.010526
	64	-0.08947	-0.17368	0.068421	0.031579	-0.03158

B.2.4 Payoff: Belongingness & Autonomy; Energising: Belongingness

(B=E, A=1)

(a) Frequency of being imitated

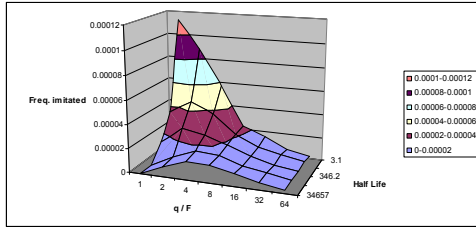

(b) Size of agent's region

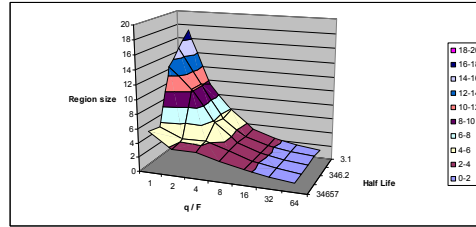

(i) Results with normal agents

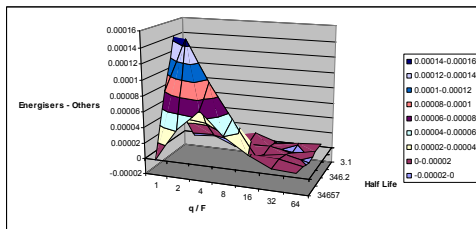

(i) Results with normal agents

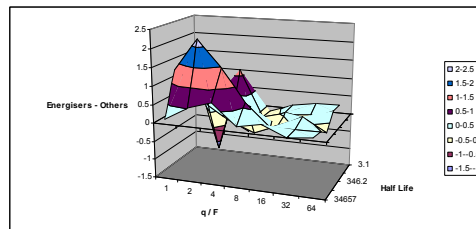

(ii) Energiser (1/6) - others

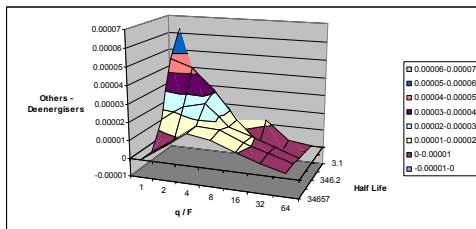

(ii) Energiser (1/6) - others

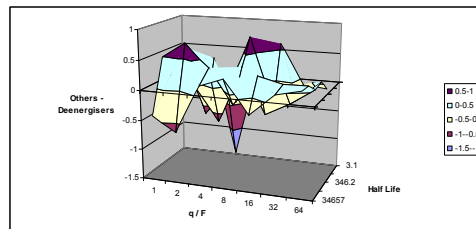

(iii) Others - De-energiser (6)

(iii) Others - De-energiser (6)

B=E, A=1 Frequency of being imitated

		All agents set to normal (Energising Parameter = 1)				
		Half life				
q / F		3.1	34.3	346.2	3465.4	34657
1		0.000113	3.52E-05	1.39E-05	0	1.25E-07
2		8.83E-05	4.62E-05	2.83E-05	0.00001	8.63E-06
4		5.71E-05	3.74E-05	2.49E-05	1.72E-05	1.56E-05
8		2.26E-05	2.11E-05	1.82E-05	1.63E-05	1.47E-05
16		1.55E-05	0.000012	1.13E-05	9.69E-06	1.07E-05
32		6.44E-06	7.75E-06	5.88E-06	6.5E-06	6.25E-06
64		2.63E-06	4.56E-06	3.44E-06	3.06E-06	2.94E-06

		Difference: Energiser (Param. = 1/6) - The Others				
		Half life				
q / F		3.1	34.3	346.2	3465.4	34657
1		-4.9E-06	2.77E-05	0.000145	7.99E-05	0
2		-2.6E-06	2.51E-05	7.38E-05	0.000148	4.22E-05
4		-1.4E-05	9.93E-06	2.61E-05	9.7E-05	6.83E-05
8		8.75E-06	2.04E-06	8.55E-06	5.3E-05	4.03E-05
16		-1.3E-06	2.57E-06	-3.3E-07	9.47E-06	2.16E-05
32		3.29E-07	-2.4E-06	5.07E-06	9.47E-06	7.11E-06
64		2.89E-06	2.11E-06	-2.8E-06	3.16E-06	5.99E-06

		Difference: The Others - De-energiser (Param. = 6)				
		Half life				
q / F		3.1	34.3	346.2	3465.4	34657
1		6.25E-05	4.74E-05	0.000015	1.97E-07	1.32E-07
2		1.89E-05	4.3E-05	2.38E-05	8.09E-06	8.42E-06
4		3.42E-06	3.12E-05	2.68E-05	1.78E-05	1.76E-05
8		7.11E-06	1.49E-05	1.47E-05	1.72E-05	1.53E-05
16		1.23E-05	2.83E-06	1.05E-05	1.13E-05	1.03E-05
32		1.78E-06	-2E-07	6.32E-06	7.17E-06	6.18E-06
64		1.32E-07	8.55E-07	1.71E-06	3.09E-06	2.76E-06

Size of agent's region

		All agents set to normal (Energising Parameter = 1)				
		Half life				
q / F		3.1	34.3	346.2	3465.4	34657
1		17.255	15.16	13.18	5.49	5.85
2		9.44	10.19	10.255	4.11	3.685
4		5.815	5.405	5.8	4.175	3.74
8		3.265	3.08	3.325	3.175	2.84
16		2.205	2.125	2.205	2.12	2.2
32		1.535	1.645	1.6	1.6	1.57
64		1.23	1.405	1.315	1.26	1.25

		Difference: Energiser (Param. = 1/6) - The Others				
		Half life				
q / F		3.1	34.3	346.2	3465.4	34657
1		-0.00526	1.010526	0.989474	1.331579	0.147368
2		-0.5	-1.20526	0.231579	2.189474	0.515789
4		-0.83684	1.147368	-0.15263	1.468421	0.710526
8		-0.15789	-0.13684	-0.41053	0.610526	0.157895
16		0.089474	0.047368	-0.14737	0.010526	0.273684
32		0.205263	-0.09474	0.178947	0.021053	-0.00526
64		0.210526	0.221053	-0.18947	0.026316	0.068421

		Difference: The Others - De-energiser (Param. = 6)				
		Half life				
q / F		3.1	34.3	346.2	3465.4	34657
1		0.278947	0.521053	0.1	0.484211	-0.40526
2		0.257895	-0.64737	-0.09474	0.747368	-0.64211
4		-1.47368	-0.18421	-0.64737	0.363158	0.163158
8		0.168421	0.763158	0.321053	-0.21053	0.305263
16		0.6	-0.38947	-0.44737	0.294737	-0.22632
32		-0.08947	-0.26842	-0.22105	0.194737	0.126316
64		-0.13158	0.084211	0.052632	0.210526	0.221053

B.2.5 Payoff: Belongingness & Competence; Energising: Belongingness

(B=E, C=1)

(a) Frequency of being imitated

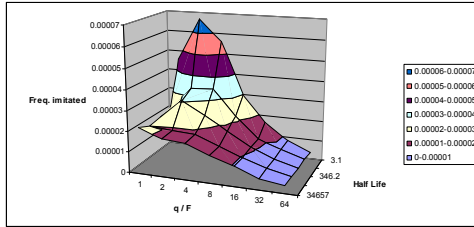

(b) Size of agent's region

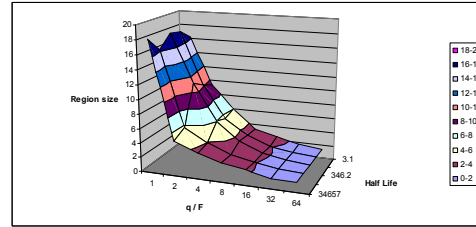

(i) Results with normal agents

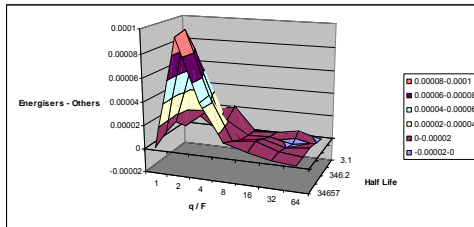

(i) Results with normal agents

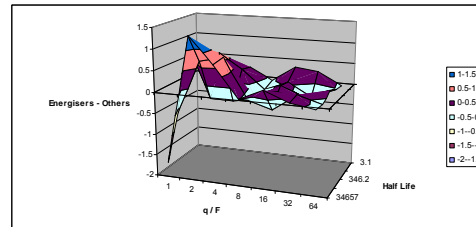

(ii) Energiser (1/6) - others

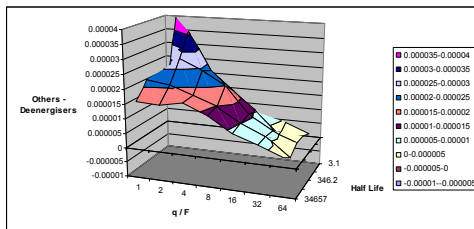

(ii) Energiser (1/6) - others

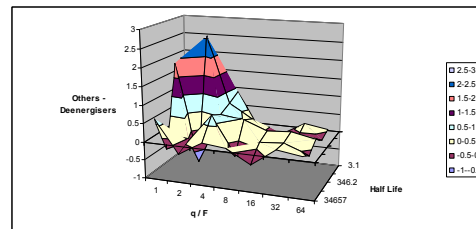

(iii) Others - De-energiser (6)

B=E, C=1 Frequency of being imitated

All agents set to normal (Energising Parameter = 1)

Half life		3.1	34.3	346.2	3465.4	34657
q / F	1	4.55E-05	2.14E-05	2.11E-05	1.99E-05	2.24E-05
	2	6.67E-05	3.38E-05	3.06E-05	1.88E-05	1.83E-05
	4	5.59E-05	3.46E-05	2.42E-05	1.82E-05	1.78E-05
	8	2.96E-05	2.18E-05	1.77E-05	1.38E-05	1.34E-05
	16	1.64E-05	1.14E-05	0.000011	9.56E-06	9.69E-06
	32	8.25E-06	7.5E-06	6.31E-06	5.94E-06	5.19E-06
	64	3.56E-06	3.81E-06	3.38E-06	3.63E-06	3.56E-06

Difference: Energiser (Param. = 1/6) - The Others

Half life		3.1	34.3	346.2	3465.4	34657
	1	1.16E-05	3.29E-06	1.3E-05	9.47E-06	2.3E-06
	2	-2E-06	1.82E-05	7.82E-05	9.86E-05	9.53E-05
	4	2.07E-05	1.27E-05	2.36E-05	4.49E-05	4.42E-05
	8	-5.3E-07	1.25E-06	3.03E-06	8.03E-06	1.3E-05
	16	0	1.71E-06	6.05E-06	1.03E-05	7.57E-06
	32	3.29E-06	-2.6E-06	1.97E-07	3.88E-06	3.36E-06
	64	-2.1E-06	5.26E-07	2.57E-06	1.91E-06	1.64E-06

Difference: The Others - De-energiser (Param. = 6)

Half life		3.1	34.3	346.2	3465.4	34657
	1	3.95E-05	1.78E-05	1.7E-05	2.18E-05	1.63E-05
	2	2.3E-05	3.61E-05	2.79E-05	2.07E-05	1.6E-05
	4	1.28E-05	2.28E-05	2.44E-05	1.79E-05	1.75E-05
	8	8.36E-06	1.61E-05	0.00002	1.49E-05	1.39E-05
	16	-5.1E-06	9.47E-06	1.08E-05	9.93E-06	9.01E-06
	32	4.14E-06	1.91E-06	5.86E-06	6.38E-06	6.32E-06
	64	6.58E-07	2.5E-06	2.7E-06	2.63E-07	3.16E-06

Size of agent's region

All agents set to normal (Energising Parameter = 1)

Half life		3.1	34.3	346.2	3465.4	34657
	1	16.27	17.6	17.88	16.215	18.17
	2	9.265	10.125	11.1	5.74	4.84
	4	5.98	5.47	6.025	3.945	3.615
	8	3.28	3.285	3.47	2.695	2.67
	16	2.4	2.045	2.205	2.04	2.145
	32	1.65	1.585	1.6	1.55	1.455
	64	1.32	1.31	1.28	1.31	1.315

Difference: Energiser (Param. = 1/6) - The Others

Half life		3.1	34.3	346.2	3465.4	34657
	1	-0.26842	0.489474	0.968421	-0.60526	-1.64737
	2	-0.15263	0.642105	-0.35789	0.684211	1.357895
	4	0.210526	0.284211	-0.35263	0.805263	0.757895
	8	-0.07368	-0.17368	-0.27368	-0.13158	0.031579
	16	0.305263	0.057895	0.105263	-0.31579	0.273684
	32	0.242105	-0.25789	-0.10526	0.084211	0.057895
	64	-0.06842	-0.01579	0.094737	-0.07368	-0.04211

Difference: The Others - De-energiser (Param. = 6)

Half life		3.1	34.3	346.2	3465.4	34657
	1	-0.48421	-0.69474	1.873684	-0.37895	0.673684
	2	-0.75263	2.552632	-0.86842	-0.06316	-0.23158
	4	0.878947	0.710526	0.552632	0.721053	0.163158
	8	-0.17368	0.315789	0.478947	-0.32105	0.1
	16	-0.24211	-0.27368	0.221053	0.126316	-0.26316
	32	0.131579	-0.05789	0.284211	0.168421	0.210526
	64	0.021053	-0.06842	0.142105	-0.07895	0.110526

B.2.6 Payoff: Competence; Energising: Competence (C=E)

(a) Frequency of being imitated

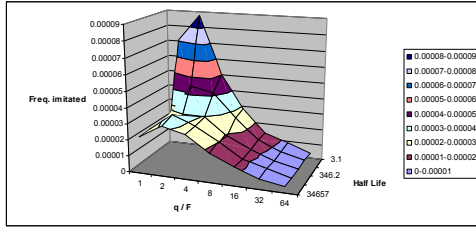

(b) Size of agent's region

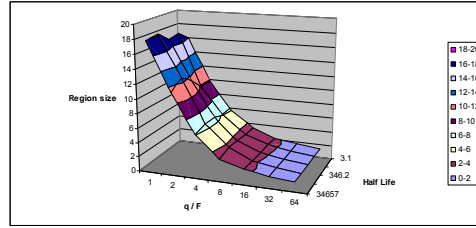

(i) Results with normal agents

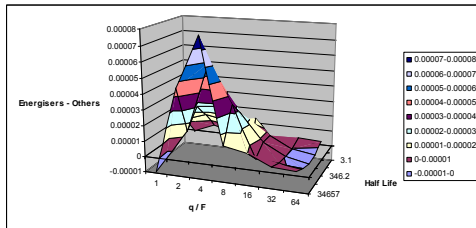

(i) Results with normal agents

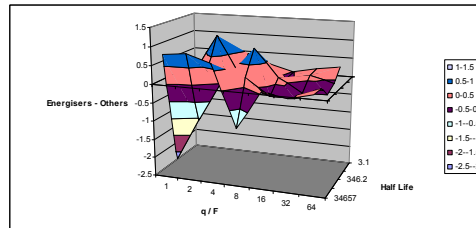

(ii) Energiser (1/6) - others

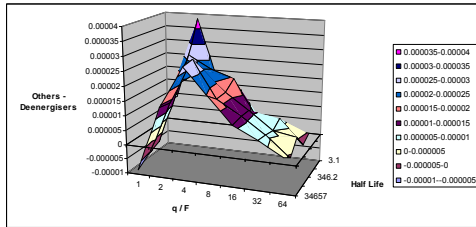

(ii) Energiser (1/6) - others

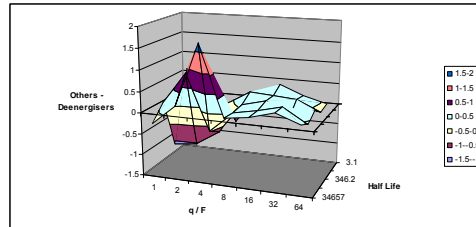

(iii) Others - De-energiser (6)

C=E Frequency of being imitated

All agents set to normal (Energising Parameter = 1)

		Half life				
		3.1	34.3	346.2	3465.4	34657
q / F	1	7.06E-05	2.26E-05	2.09E-05	2.31E-05	2.27E-05
	2	8.76E-05	4.46E-05	2.91E-05	3.36E-05	3.13E-05
	4	5.03E-05	4.16E-05	2.94E-05	2.84E-05	2.78E-05
	8	2.84E-05	2.66E-05	0.000019	2.03E-05	1.81E-05
	16	1.35E-05	1.36E-05	1.21E-05	1.11E-05	1.17E-05
	32	8.56E-06	7.56E-06	6.94E-06	7.19E-06	6.38E-06
	64	3.56E-06	3.81E-06	3.56E-06	3.25E-06	4.06E-06

Difference: Energiser (Param. = 1/6) - The Others

		Half life				
		3.1	34.3	346.2	3465.4	34657
1	1	-4.6E-07	1.26E-05	1.32E-06	-5.2E-06	-9E-06
	2	5.59E-06	1.7E-05	2.65E-05	1.47E-05	4.58E-05
	4	5.26E-07	1.45E-05	2.84E-05	5.93E-05	7.86E-05
	8	1.33E-05	-5.1E-06	2.55E-05	3.45E-05	1.28E-05
	16	-2.8E-06	7.3E-06	7.43E-06	1.51E-06	1.01E-05
	32	2.83E-06	-2E-07	-1.3E-07	4.61E-07	3.75E-06
	64	1.91E-06	-2.6E-06	-3.3E-06	-9.9E-07	2.7E-06

Difference: The Others - De-energiser (Param. = 6)

		Half life				
		3.1	34.3	346.2	3465.4	34657
1	1	8.88E-06	9.34E-06	-3.6E-06	-5.7E-06	-8.5E-06
	2	3.81E-05	2.67E-05	1.84E-05	1.34E-05	1.41E-05
	4	1.35E-05	2.22E-05	2.39E-05	2.89E-05	2.81E-05
	8	9.41E-06	1.94E-05	1.66E-05	1.64E-05	1.95E-05
	16	1.64E-06	6.38E-06	1.12E-05	1.14E-05	1.08E-05
	32	1.12E-06	6.64E-06	0.000005	5.99E-06	6.84E-06
	64	-5.3E-07	-1.9E-06	3.55E-06	-8.6E-07	1.97E-06

(iii) Others - De-energiser (6)

Size of agent's region

All agents set to normal (Energising Parameter = 1)

		Half life				
		3.1	34.3	346.2	3465.4	34657
1	1	16.015	17.225	16.905	18.285	17.88
	2	9.79	9.715	11.465	12.54	11.39
	4	5.68	5.84	6.465	6.535	6.1
	8	3.365	3.29	3.455	3.66	3.115
	16	2.125	2.26	2.17	2.095	2.2
	32	1.685	1.635	1.645	1.66	1.61
	64	1.29	1.31	1.31	1.265	1.355

Difference: Energiser (Param. = 1/6) - The Others

		Half life				
		3.1	34.3	346.2	3465.4	34657
1	1	0.315789	-0.2632	-0.68947	-2.21053	0.810526
	2	0.110526	1.021053	0.236842	-1.05789	0.878947
	4	0.426316	-0.07368	-0.65789	0.036842	0.684211
	8	0.163158	-0.12632	0.863158	0.231579	-0.952632
	16	-0.00526	-0.05263	0.131579	-0.21053	0.052632
	32	0.136842	0.105263	-0.22632	-0.20526	-0.04211
	64	0.231579	-0.06842	-0.22105	0.110526	0.115789

Difference: The Others - De-energiser (Param. = 6)

		Half life				
		3.1	34.3	346.2	3465.4	34657
1	1	0.478947	0.473684	-1.08947	0.126316	-0.22632
	2	0.321053	0.494737	-1.00526	0.884211	0.242105
	4	-0.71053	-0.08947	-0.64211	-0.44737	1.721053
	8	-0.01053	0.247368	0.094737	0.042105	0.078947
	16	0.347368	0.210526	0.236842	0.152632	0.157895
	32	0.126316	0.168421	-0.09474	0.3	0.326316
	64	-0.04211	-0.08947	0.105263	-0.04737	0.121053

B.2.7 Payoff: Competence & Belongingness; Energising: Competence

(C=E, B=1)

(a) Frequency of being imitated

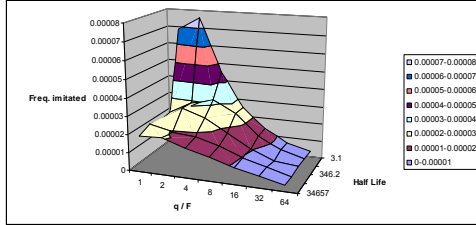

(b) Size of agent's region

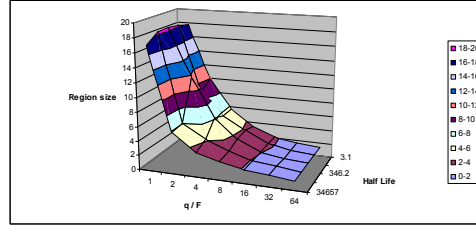

(i) Results with normal agents

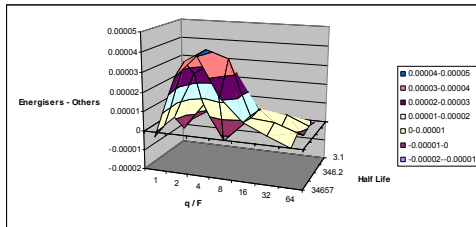

(i) Results with normal agents

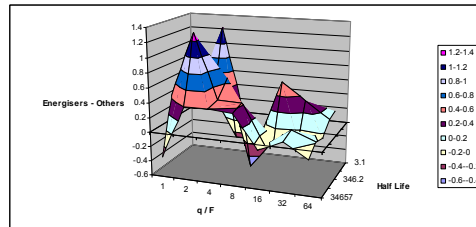

(ii) Energiser (1/6) - others

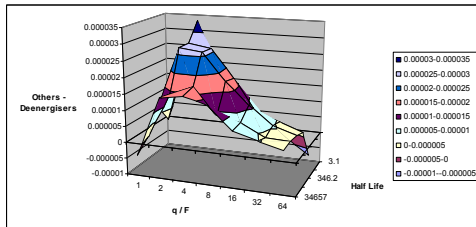

(ii) Energiser (1/6) - others

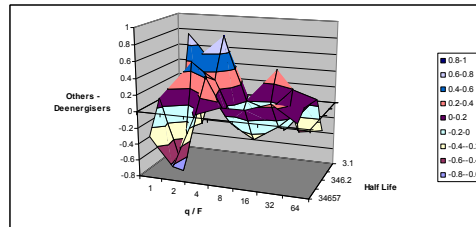

(iii) Others - De-energiser (6)

C=E, B=1 Frequency of being imitated

All agents set to normal (Energising Parameter = 1)		Half life				
		3.1	34.3	346.2	3465.4	34657
q / F	1	6.83E-05	2.21E-05	2.12E-05	2.28E-05	0.00002
	2	7.59E-05	2.88E-05	2.92E-05	1.96E-05	2.06E-05
	4	4.53E-05	3.19E-05	2.53E-05	1.85E-05	1.64E-05
	8	0.000025	2.54E-05	1.77E-05	1.48E-05	1.31E-05
	16	1.37E-05	1.33E-05	1.04E-05	9.75E-06	9.13E-06
	32	6.88E-06	7.13E-06	5.25E-06	6.38E-06	6.31E-06
	64	3.44E-06	3.44E-06	3.75E-06	2.88E-06	3.5E-06

Difference: Energiser (Param. = 1/6) - The Others		Half life				
		3.1	34.3	346.2	3465.4	34657
q / F	1	-6.4E-06	-8.3E-06	1.25E-06	2.63E-07	-2.3E-06
	2	4.61E-07	6.05E-06	2.61E-05	3.41E-05	2.88E-05
	4	-1.2E-05	-1.3E-05	3.2E-05	4.11E-05	4.03E-05
	8	-2.8E-06	-1.9E-06	1.85E-05	3.73E-05	2.08E-05
	16	-4E-06	5.59E-06	1.02E-05	8.75E-06	9.74E-06
	32	-6.9E-06	5.07E-06	1.38E-06	7.76E-06	4.41E-06
	64	-9.9E-07	3.29E-07	-9.9E-07	3.68E-06	-1.3E-07

Difference: The Others - De-energiser (Param. = 6)		Half life				
		3.1	34.3	346.2	3465.4	34657
q / F	1	9.87E-06	1.32E-06	7.5E-06	1.32E-07	-3.6E-06
	2	3.31E-05	2.71E-05	2.69E-05	1.41E-05	1.49E-05
	4	1.61E-05	2.59E-05	2.61E-05	1.7E-05	1.61E-05
	8	2.63E-07	1.7E-05	1.76E-05	9.01E-06	1.41E-05
	16	3.75E-06	6.38E-06	1.09E-05	7.63E-06	7.37E-06
	32	-2.8E-06	4.34E-06	5.39E-06	3.88E-06	5.2E-06
	64	-8E-06	1.64E-06	3.09E-06	3.55E-06	3.22E-06

Size of agent's region

All agents set to normal (Energising Parameter = 1)		Half life				
		3.1	34.3	346.2	3465.4	34657
q / F	1	17.8	18.175	18.38	18.295	17.12
	2	10.005	8.75	11.675	6.01	5.755
	4	5.59	5.585	6.195	4.135	3.425
	8	3.345	3.75	3.475	2.865	2.61
	16	2.095	2.17	2.025	1.895	1.9
	32	1.535	1.57	1.475	1.64	1.635
	64	1.28	1.295	1.32	1.26	1.305

Difference: Energiser (Param. = 1/6) - The Others		Half life				
		3.1	34.3	346.2	3465.4	34657
q / F	1	0.294737	0.163158	0.273684	0.436842	-0.32632
	2	1.226316	0.278947	0.284211	1.305263	0.384211
	4	-0.07895	-0.27368	0.647368	0.436842	0.4
	8	-0.27895	-0.27895	-0.56316	0.426316	0.373684
	16	0.347368	0.578947	-0.14211	-0.14211	-0.07368
	32	-0.22105	0.347368	-0.14211	0.131579	0.073684
	64	0.136842	0.115789	-0.04211	0.010526	-0.12105

Difference: The Others - De-energiser (Param. = 6)		Half life				
		3.1	34.3	346.2	3465.4	34657
q / F	1	0.747368	-0.47895	-0.19474	0.1	-0.28947
	2	0.410526	-0.34737	0.505263	-0.78421	-0.63158
	4	0.389474	0.8	0.305263	0.415789	0.036842
	8	-0.20526	0.005263	-0.27895	-0.1	0.147368
	16	0.357895	-0.09474	-0.14211	-0.28947	0.152632
	32	-0.43158	0.194737	-0.21579	-0.09474	0.247368
	64	-0.37895	0.1	0.131579	0.152632	0.052632

B.2.8 Payoff: Belongingness; Energising: Belongingness; Population =

10 (B=E, N=10)

(a) Frequency of being imitated

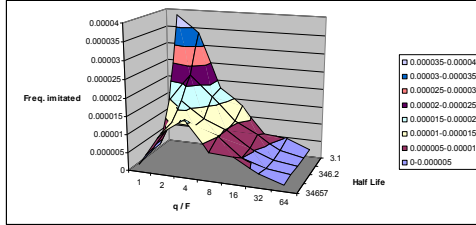

(i) Results with normal agents

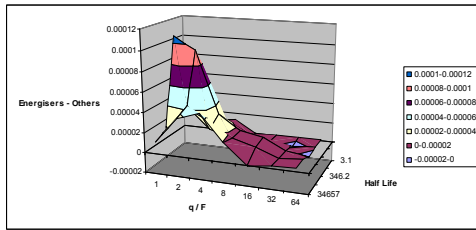

(ii) Energiser (1/6) - others

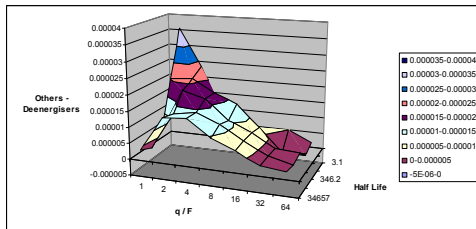

(iii) Others - De-energiser (6)

B=E, N=10 Frequency of being imitated

All agents set to normal (Energising Parameter = 1)

		Half life				
		3.1	34.3	346.2	3465.4	34657
q / F	1	3.84E-05	1.48E-05	3.5E-06	0.000003	2.13E-06
	2	3.36E-05	2.26E-05	1.68E-05	1.25E-05	1.16E-05
	4	1.79E-05	1.69E-05	1.24E-05	1.23E-05	1.59E-05
	8	1.31E-05	1.05E-05	9.75E-06	1.01E-05	7.88E-06
	16	5.25E-06	7.13E-06	5.5E-06	0.000005	7.38E-06
	32	4.75E-06	3.25E-06	2.75E-06	2.88E-06	3.88E-06
	64	2.13E-06	0.000002	0.000002	0.000002	1.63E-06

Difference: Energiser (Param. = 1/6) - The Others

		Half life				
		3.1	34.3	346.2	3465.4	34657
1	1	1.38E-05	3.47E-05	0.000107	1.71E-05	1.22E-05
	2	8.19E-06	1.85E-05	9.44E-05	4.38E-05	3.78E-05
	4	1.32E-05	1.85E-05	3.18E-05	2.29E-05	4.53E-05
	8	-8.3E-07	6.67E-06	1.68E-05	1.63E-05	1.92E-05
	16	8.33E-07	1.25E-06	1.29E-05	0.00001	-2.8E-07
	32	8.33E-07	-1.3E-06	1.67E-06	1.81E-06	2.5E-06
	64	1.25E-06	6.94E-07	-1.4E-06	4.03E-06	3.47E-06

Difference: The Others - De-energiser (Param. = 6)

		Half life				
		3.1	34.3	346.2	3465.4	34657
1	1	3.54E-05	2.04E-05	5.56E-06	1.67E-06	3.47E-06
	2	2.33E-05	2.08E-05	1.88E-05	1.33E-05	1.43E-05
	4	7.78E-06	1.69E-05	1.68E-05	1.44E-05	1.47E-05
	8	3.06E-06	1.39E-05	1.07E-05	1.17E-05	9.58E-06
	16	8.33E-07	7.08E-06	7.5E-06	7.22E-06	6.67E-06
	32	0.000005	-2.8E-07	3.47E-06	3.47E-06	3.06E-06
	64	1.39E-06	-2.8E-07	2.78E-06	1.81E-06	2.22E-06

(b) Size of agent's region

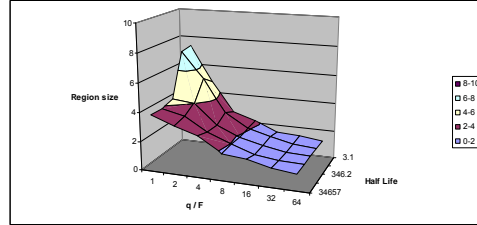

(i) Results with normal agents

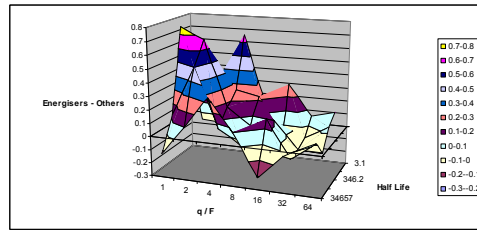

(ii) Energiser (1/6) - others

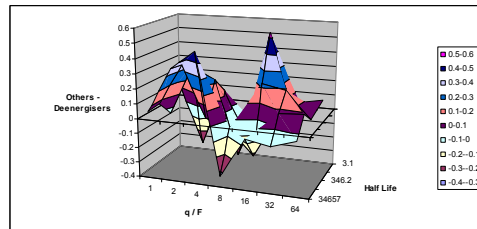

(iii) Others - De-energiser (6)

Size of agent's region

All agents set to normal (Energising Parameter = 1)

		Half life				
		3.1	34.3	346.2	3465.4	34657
1	1	7.36	7.24	4.18	3.92	3.94
	2	4.77	5.38	4.02	3.56	3.34
	4	2.63	3.07	2.61	2.63	2.85
	8	2.14	2.05	1.92	1.97	1.87
	16	1.47	1.62	1.53	1.46	1.72
	32	1.35	1.27	1.23	1.25	1.33
	64	1.18	1.17	1.17	1.19	1.13

Difference: Energiser (Param. = 1/6) - The Others

		Half life				
		3.1	34.3	346.2	3465.4	34657
1	1	-0.06667	0.355556	0.755556	0.122222	-0.12222
	2	-0.07778	0.266667	0.666667	0.5	0.1
	4	0.655556	0.255556	0.166667	0.055556	0.333333
	8	0.088889	0.222222	0.044444	-0.055556	0.1
	16	0.288889	-0.133333	0.1	0.166667	-0.21111
	32	0.055556	-0.06667	-0.1	-0.11111	-0.03333
	64	0.1	0.033333	-0.11111	0.022222	0.066667

Difference: The Others - De-energiser (Param. = 6)

		Half life				
		3.1	34.3	346.2	3465.4	34657
1	1	-0.08889	0.111111	-0.04444	0.066667	0.055556
	2	-0.07778	-0.28889	0.3	0.344444	0.355556
	4	-0.14444	0.111111	0.222222	0	0.477778
	8	-0.15556	-0.21111	-0.28889	-0.055556	-0.32222
	16	0.111111	0.533333	0.222222	-0.22222	-0.055556
	32	0.022222	-0.02222	0.188889	0.077778	-0.08889
	64	0.055556	0.033333	0.011111	0.088889	-0.03333

B.3 Claims Tests

The claims were given in 7.2, and the explanation of the tests is given in 8.3, 8.4 and 8.5. For convenience the scoring of claims 1 and 2 tests is given in Table 14, with x referring to the energising parameter value for the one energiser or de-energiser in each population. For each claim test six t tests are performed, each with a confidence level chosen to give a particular overall confidence level for the combined test. The t tests are 1-tailed, and we are comparing two means.

Tests were performed for each combination of decay rate - referred to here by its half life - and value of (q / F) - the number of traits divided by the number of features. The parameter values used are those given for the charts earlier.

Table 14 Scoring for tests of claims 1 and 2

Score	Explanation
3	5) For x in $\{1/6, 1/3\}$ confidence interval (CI) for mean Energiser above that for mean of Other agents, &; 6) for $x = 1/1.5$ CI for Energiser not below that for Others, &; 7) for x in $\{6, 3\}$ confidence interval (CI) for mean De-energiser below that for mean of Other agents, &; 8) for $x = 1.5$ CI for De-energiser not above that for Others.
2	Conditions (1), (2) from above hold, but not (3), (4)
1	Conditions (3), (4) from above hold, but not (1), (2)
0	None of the conditions are met.

B.3.1 Claim 1: Based on Frequency of being imitated

The following set of tables shows the results of tests of claim 1 - using Frequency of being imitated - for the agent-energy model. At each combination of (q/F) (rows) and half life (columns) the overall confidence level is 95%. Eight scenarios are shown - the same as described earlier for the charts.

	3.1	34.3	346.2	3465.4	34657
1	0	1	3	0	0
2	0	1	3	3	3
4	0	1	3	3	3
8	0	0	1	3	3
16	0	0	1	3	3
32	0	0	0	1	1
64	0	0	0	1	1

(i) $B=E$

	3.1	34.3	346.2	3465.4	34657
1	0	0	0	0	0
2	0	0	0	0	0
4	0	0	0	0	0
8	0	0	0	0	0
16	0	0	0	0	0
32	0	0	0	0	0
64	0	0	0	0	0

(v) $A=E, B=I$

	3.1	34.3	346.2	3465.4	34657
1	0	1	3	2	0
2	0	1	3	3	3
4	0	0	1	3	3
8	0	0	1	3	3
16	0	0	0	1	3
32	0	0	1	0	1
64	0	0	0	1	1

(ii) $B=E, A=I$

	3.1	34.3	346.2	3465.4	34657
1	0	0	0	0	0
2	0	0	0	0	0
4	0	0	0	1	1
8	0	0	0	1	1
16	0	0	1	0	1
32	0	0	0	1	0
64	0	0	1	0	0

(vi) $C=E$

	3.1	34.3	346.2	3465.4	34657
1	0	1	0	1	1
2	0	0	3	3	3
4	0	0	1	3	3
8	0	1	1	1	1
16	0	0	1	1	1
32	0	0	0	0	1
64	0	0	0	0	0

(iii) $B=E, C=I$

	3.1	34.3	346.2	3465.4	34657
1	0	0	0	0	0
2	0	0	0	2	0
4	0	0	1	3	3
8	0	0	1	1	3
16	0	0	0	0	1
32	0	0	0	0	1
64	0	0	0	0	1

(vii) $C=E, B=I$

	3.1	34.3	346.2	3465.4	34657
1	0	0	0	0	0
2	0	0	0	0	0
4	0	0	0	0	0
8	0	0	0	0	0
16	0	0	0	0	0
32	0	0	0	0	0
64	0	0	0	0	0

(iv) $A=E$

	3.1	34.3	346.2	3465.4	34657
1	0	1	3	3	3
2	0	1	3	3	3
4	0	1	3	3	3
8	0	0	3	3	3
16	0	0	1	1	1
32	0	0	1	1	1
64	0	0	1	1	1

(viii) $B=E, Population = 10$

B.3.2 Other claims tests

For claim 2 - based on the output metric Size of agent's region - we were unable to obtain any points where a non-zero score was achieved. We reduced the overall confidence level from 95% to 80% and obtained one point for scenario B=E at (half life = 3465.4, $q/F = 2$) which scored 2.

For claim 3 - based on population fitness improvement - results were no better. A reminder of the scoring for claim 3 tests is given in Table 15. With a confidence level of 80% the scores obtained were:

33 at (HL = 346.2, $q/F = 4$) for B=E, C=1;

16 at (HL = 34.3, $q/F = 16$) for scenario C=E;

4 at (HL = 34657, $q/F = 8$) for C=E, B=1.

Table 15 Scoring for tests of claim 3

Score	Explanation
0	None of the following passed
+1	De-energiser-population (D) > Energiser-population (E)
+2	E > D
+4	Non-energiser, non-de-energiser population (N) > E
+8	N > D
+16	E > N
+32	D > N

Appendix C Results with the feature-energy model

(FeatureE)

C.1 Introduction

We collate in this appendix the results of all experiments performed with the feature-energy model in Chapter 9. The model itself was described in Chapter 6.

Results for four scenarios are shown. As explained in Table 16 they are distinguished by their payoff functions. See 6.6 and 6.7 for the definitions of the payoff function components, Belongingness and Competence, and the use of the energising parameter. 20 simulation replications were run for each scenario.

Table 16 Feature-energy model scenarios explained

Code	Explanation
B=E	Payoffs based on Belongingness. Energising alters Belongingness
B=E, C=1	Payoffs based on Belongingness and Competence. Energising alters Belongingness
C=E	Payoffs based on Competence. Energising alters Competence
C=E, B=1	Payoffs based on Competence and Belongingness. Energising alters Competence

C.2 Feature-energy model behaviour

The charts are as described for the agent-energy model in Appendix B.

C.2.1 Payoff: Belongingness; Energising: Belongingness (B=E)

(a) Frequency of being imitated

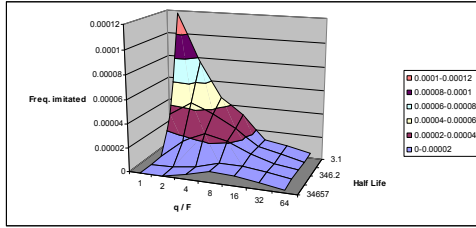

(b) Size of agent's region

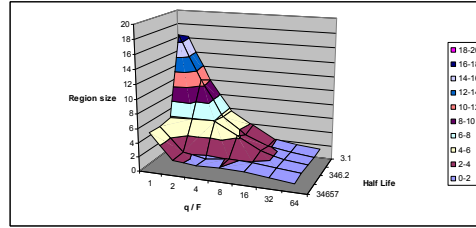

(i) Results with normal agents

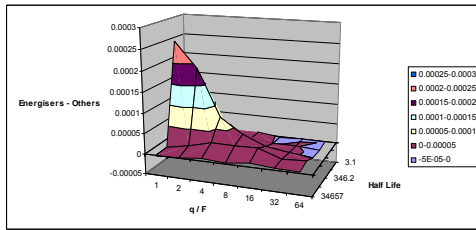

(i) Results with normal agents

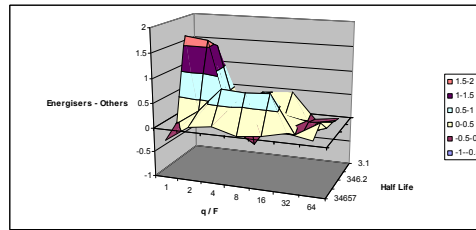

(ii) Energiser (1/6) - others

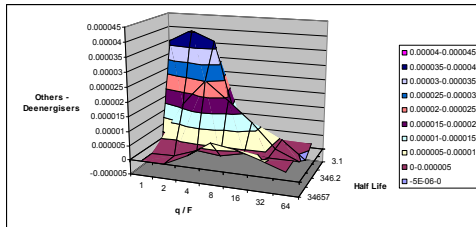

(ii) Energiser (1/6) - others

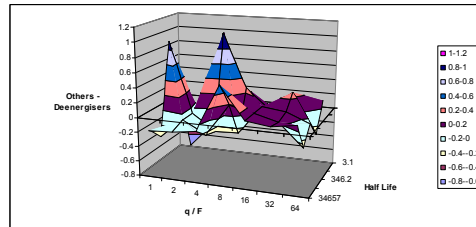

(iii) Others - De-energiser (6)

B=E **Frequency of being imitated**

All agents set to normal (Energising Parameter = 1)

		Half life				
		3.1	34.3	346.2	3465.4	34657
q / F	1	0.000118	3.26E-05	3.75E-07	0	0
	2	7.62E-05	4.49E-05	1.67E-05	4.38E-07	1.88E-07
	4	4.64E-05	3.68E-05	2.56E-05	3.25E-06	4.25E-06
	8	3.26E-05	2.63E-05	2.09E-05	9.19E-06	9.19E-06
	16	1.18E-05	1.21E-05	1.23E-05	9.06E-06	8.13E-06
	32	8.69E-06	7.88E-06	6.56E-06	6.38E-06	5.25E-06
	64	4.13E-06	3.19E-06	3.75E-06	3.63E-06	2.25E-06

Difference: Energiser (Param. = 1/6) - The Others

		Half life				
		3.1	34.3	346.2	3465.4	34657
1	2.8E-05	3.82E-05	0.000252	0	0	
2	1.03E-05	1.12E-05	0.00019	1.07E-05	-1.3E-07	
4	-8.2E-06	2.38E-05	7.24E-05	2.51E-05	5.39E-06	
8	6.58E-06	6.91E-06	3.45E-05	0.000025	2.17E-06	
16	-2E-06	-2.6E-07	1.21E-05	2.61E-05	9.47E-06	
32	-2.6E-07	4.61E-07	2.57E-06	6.25E-06	4.34E-06	
64	-2E-07	-2.9E-06	-3E-06	1.03E-05	3.82E-06	

Difference: The Others - De-energiser (Param. = 6)

		Half life				
		3.1	34.3	346.2	3465.4	34657
1	1.91E-05	3.64E-05	1.51E-06	0	0	
2	3.19E-05	4.05E-05	1.63E-05	1.32E-07	6.58E-08	
4	1.62E-05	3.73E-05	2.51E-05	3.03E-06	4.08E-06	
8	4.14E-06	9.14E-06	1.89E-05	2.11E-06	9.41E-06	
16	2.7E-06	1.12E-06	1.22E-05	4.01E-06	8.09E-06	
32	6.58E-07	4.41E-06	3.95E-06	3.49E-06	5.46E-06	
64	1.45E-06	-1.9E-06	4.61E-07	3.55E-06	2.7E-06	

(iii) Others - De-energiser (6)

Size of agent's region

All agents set to normal (Energising Parameter = 1)

		Half life				
		3.1	34.3	346.2	3465.4	34657
1	16.27	17.02	5.8	5.5	5.65	
2	10.04	10.73	5.875	2.225	2.17	
4	5.57	5.64	6.005	1.61	1.81	
8	3.79	3.37	4.225	2.03	2	
16	2.035	2.065	2.47	1.96	1.885	
32	1.635	1.6	1.64	1.63	1.535	
64	1.335	1.26	1.325	1.335	1.19	

Difference: Energiser (Param. = 1/6) - The Others

		Half life				
		3.1	34.3	346.2	3465.4	34657
1	-0.41053	0.931579	1.684211	-0.03684	-0.23158	
2	-0.62632	1.426316	1.626316	0.289474	0.089474	
4	-0.36316	-0.26842	-0.14737	0.784211	0.152632	
8	0.268421	0.526316	-0.45789	0.752632	0.015789	
16	0.442105	0.063158	0.268421	0.778947	0.068421	
32	-0.11053	-0.03158	-0.14737	0.005263	0.184211	
64	-0.03684	0.031579	0.052632	0.294737	0.089474	

Difference: The Others - De-energiser (Param. = 6)

		Half life				
		3.1	34.3	346.2	3465.4	34657
1	-0.78947	0.247368	0.910526	-0.34211	-0.15789	
2	-0.45789	-0.24737	-0.07895	-0.07368	-0.14211	
4	0.505263	1.010526	-0.29474	-0.24737	-0.09474	
8	-0.17368	0.263158	-0.28421	0.194737	0.542105	
16	-0.11579	-0.00526	0.115789	0.110526	0.105263	
32	-0.15263	0.263158	0.078947	0.031579	0.063158	
64	0.094737	-0.29474	-0.04737	-0.26842	0.126316	

C.2.2 Payoff: Belongingness & Competence; Energising: Belongingness

(B=E, C=1)

(a) Frequency of being imitated

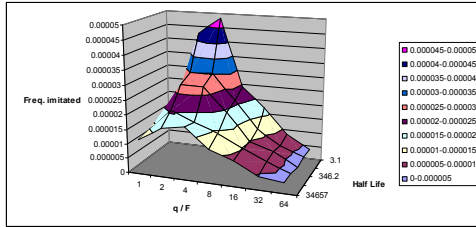

(b) Size of agent's region

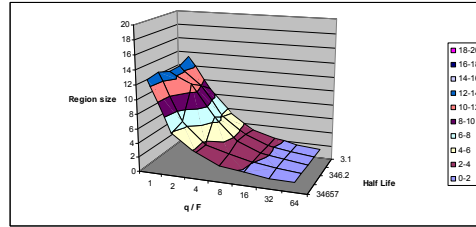

(i) Results with normal agents

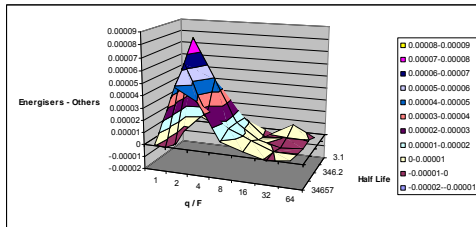

(i) Results with normal agents

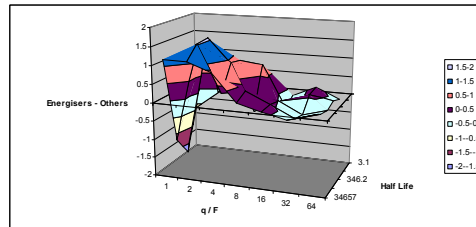

(ii) Energiser (1/6) - others

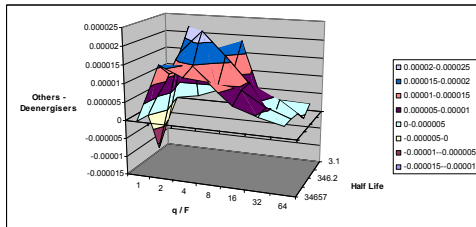

(ii) Energiser (1/6) - others

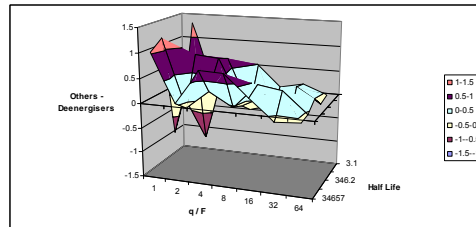

(iii) Others - De-energiser (6)

B=E, C=1 Frequency of being imitated

All agents set to normal (Energising Parameter = 1)

q / F	3.1	34.3	346.2	3465.4	34657
1	1.25E-05	1.23E-05	1.21E-05	1.26E-05	1.19E-05
2	4.24E-05	2.98E-05	2.74E-05	2.06E-05	1.68E-05
4	4.84E-05	3.03E-05	2.74E-05	1.73E-05	1.82E-05
8	2.41E-05	2.12E-05	1.92E-05	1.43E-05	1.15E-05
16	0.000017	1.18E-05	9.81E-06	1.02E-05	8.75E-06
32	8.19E-06	6.56E-06	7.19E-06	6.56E-06	4.56E-06
64	3.63E-06	3.5E-06	2.81E-06	3.63E-06	3.56E-06

Difference: Energiser (Param. = 1/6) - The Others

q / F	3.1	34.3	346.2	3465.4	34657
1	7.76E-06	-3.9E-06	-1.1E-05	-7.3E-06	1.45E-06
2	0	1.2E-05	8.13E-05	6.43E-05	4.89E-05
4	1.32E-06	8.95E-06	4.82E-05	2.45E-05	3.93E-05
8	2.17E-06	1.28E-05	1.44E-05	1.49E-05	9.34E-06
16	-4.2E-06	-1.3E-06	2.11E-06	7.11E-06	4.28E-06
32	5.66E-06	-4.6E-07	-3.2E-06	0	-9.2E-07
64	-3.3E-06	1.32E-07	-9.9E-07	6.58E-08	1.58E-06

Difference: The Others - De-energiser (Param. = 6)

q / F	3.1	34.3	346.2	3465.4	34657
1	0	-5E-06	-1.1E-05	6.58E-08	1.32E-07
2	1.05E-06	2.27E-05	1.64E-05	1.2E-05	1.59E-05
4	3.42E-06	1.66E-05	2.28E-05	1.46E-05	1.31E-05
8	1.84E-05	1.14E-05	1.65E-05	9.14E-06	1.24E-05
16	-6.6E-08	4.08E-06	9.74E-06	9.34E-06	6.78E-06
32	1.97E-06	3.82E-06	1.97E-07	5.39E-06	4.61E-06
64	1.64E-06	-5.3E-07	2.57E-06	3.09E-06	2.96E-06

(iii) Others - De-energiser (6)

All agents set to normal (Energising Parameter = 1)

Size of agent's region

q / F	3.1	34.3	346.2	3465.4	34657
1	13.33	12.545	12.485	13.135	12.865
2	8.75	10.03	11.01	6.545	5.9
4	5.31	5.72	6.595	3.635	3.72
8	3.13	3.42	3.46	2.805	2.26
16	2.245	2.125	2.14	2.02	1.9
32	1.635	1.625	1.74	1.635	1.405
64	1.335	1.305	1.24	1.325	1.325

Difference: Energiser (Param. = 1/6) - The Others

q / F	3.1	34.3	346.2	3465.4	34657
1	0.815789	-0.61579	-1.74737	-1.17368	1.184211
2	-0.11579	-0.10526	1.557895	1.515789	1.178947
4	0.121053	0.863158	0.931579	0.242105	0.952632
8	-0.03684	0.789474	-0.34737	0.363158	0.221053
16	-0.17895	-0.38421	-0.00526	0.073684	0.052632
32	0.110526	0.068421	-0.32632	-0.24737	-0.08947
64	-0.16842	-0.05263	-0.13684	-0.04737	0.110526

Difference: The Others - De-energiser (Param. = 6)

q / F	3.1	34.3	346.2	3465.4	34657
1	1.305263	-0.20526	-0.85263	1.221053	1.036842
2	-0.08421	-1.05789	0.842105	-0.14737	0.063158
4	0.436842	0.7	0.794737	0.226316	0.752632
8	0.494737	-0.34737	-0.13684	-0.04737	0.747368
16	0.057895	-0.21053	0.110526	0.447368	0.305263
32	0.163158	0.221053	-0.21053	0.373684	-0.09474
64	-0.03158	-0.08947	0.131579	-0.03684	-0.05789

C.2.3 Payoff: Competence; Energising: Competence (C=E)

(a) Frequency of being imitated

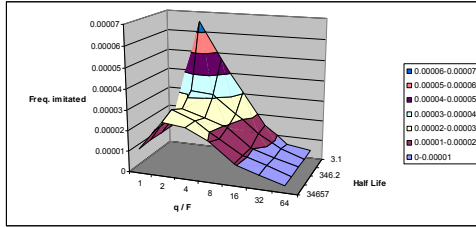

(b) Size of agent's region

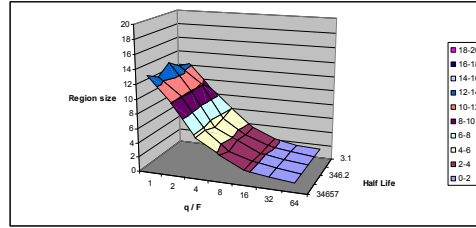

(i) Results with normal agents

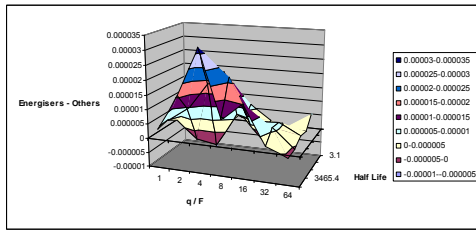

(i) Results with normal agents

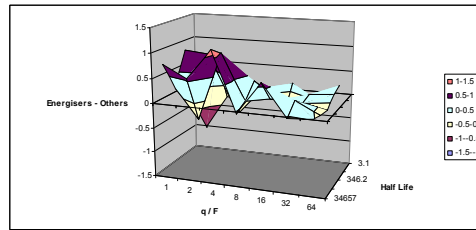

(ii) Energiser (1/6) - others

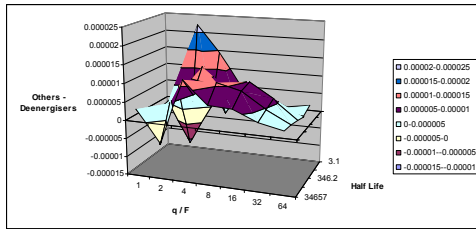

(ii) Energiser (1/6) - others

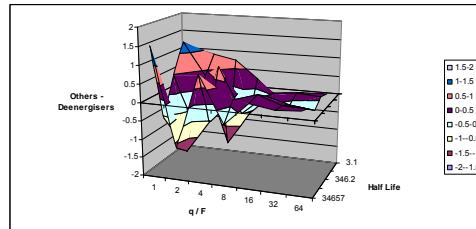

(iii) Others - De-energiser (6)

C=E Frequency of being imitated

All agents set to normal (Energising Parameter = 1)

		Half life				
		3.1	34.3	346.2	3465.4	34657
q / F	1	1.28E-05	1.26E-05	1.26E-05	1.25E-05	0.000012
	2	6.51E-05	3.24E-05	2.63E-05	2.88E-05	2.58E-05
	4	4.69E-05	3.12E-05	2.27E-05	2.46E-05	2.49E-05
	8	3.07E-05	2.26E-05	1.92E-05	1.71E-05	1.95E-05
	16	1.45E-05	1.38E-05	1.03E-05	1.06E-05	1.03E-05
	32	5.94E-06	7.5E-06	6.69E-06	7.19E-06	6.69E-06
	64	4.06E-06	3.5E-06	3.75E-06	3.25E-06	3.38E-06

Size of agent's region

All agents set to normal (Energising Parameter = 1)

		Half life				
		3.1	34.3	346.2	3465.4	34657
	1	12.26	12.6	13.69	12.465	13.415
	2	8.905	10.185	9.85	9.95	10.02
	4	6.04	5.435	5.105	5.7	5.63
	8	3.485	3.33	3.63	3.13	3.735
	16	2.135	2.165	2.09	2.115	2.11
	32	1.52	1.655	1.615	1.67	1.63
	64	1.315	1.3	1.33	1.285	1.28

Difference: Energiser (Param. = 1/6) - The Others

		Half life				
		3.1	34.3	346.2	3465.4	34657
	1	-5.7E-06	5.33E-06	2.3E-06	4.61E-06	3.62E-06
	2	2.11E-06	8.82E-06	-3.7E-06	9.21E-06	1.58E-05
	4	-9.2E-07	1.95E-05	-5.1E-06	1.87E-05	3.22E-05
	8	6.38E-06	3.42E-06	6.78E-06	2.15E-05	9.21E-06
	16	1.12E-06	-4.4E-06	0.000005	6.12E-06	1.51E-05
	32	-4.9E-06	1.32E-06	5.66E-06	5.92E-06	2.04E-06
	64	0.000005	8.55E-07	1.64E-06	-5.3E-07	-9.9E-07

Difference: Energiser (Param. = 1/6) - The Others

		Half life				
		3.1	34.3	346.2	3465.4	34657
	1	-1.04211	-0.46842	0.9	0.205263	0.805263
	2	-0.28421	0.652632	0.847368	-0.38421	0.557895
	4	-0.32105	-0.45789	-0.06842	0.989474	1.152632
	8	-0.07895	0.110526	0.378947	0.073684	-0.03684
	16	0.136842	-0.25789	0.026316	0.173684	0.605263
	32	-0.37895	0.052632	0.005263	0.184211	-0.02632
	64	0.173684	0.110526	-0.08421	-0.06316	0.010526

Difference: The Others - De-energiser (Param. = 6)

		Half life				
		3.1	34.3	346.2	3465.4	34657
	1	2.57E-06	5.26E-07	-6.6E-08	-1.8E-06	3.49E-06
	2	2.21E-05	-1.1E-05	3.82E-06	3.95E-06	-5.5E-06
	4	1.45E-05	2.63E-07	1.29E-05	6.84E-06	1.25E-05
	8	4.87E-06	4.74E-06	8.55E-07	1.08E-05	6.45E-06
	16	3.09E-06	5.66E-06	9.93E-06	9.01E-06	6.12E-06
	32	3.29E-07	1.45E-06	5.92E-06	4.74E-06	3.22E-06
	64	1.38E-06	-1.3E-07	7.89E-07	1.45E-06	1.91E-06

Difference: The Others - De-energiser (Param. = 6)

		Half life				
		3.1	34.3	346.2	3465.4	34657
	1	1.005263	1.273684	0.473684	-0.56842	1.531579
	2	0.863158	0.368421	-1.06316	-1.43158	-1.13158
	4	0.721053	-1.53158	0.810526	-0.53684	0.894737
	8	0.242105	-0.58421	-0.41053	0.121053	-0.35263
	16	-0.4	0.042105	0.126316	0.331579	0.28421
	32	-0.06316	0.1	-0.05789	0.094737	0.157895
	64	-0.01579	0.052632	-0.13684	0.078947	0.210526

C.2.4 Payoff: Competence & Belongingness; Energising: Competence

(C=E, B=1)

(a) Frequency of being imitated

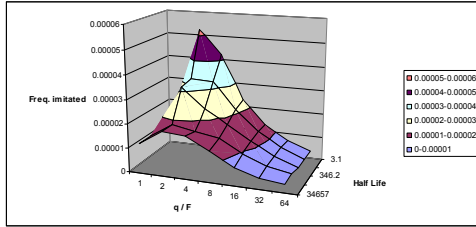

(b) Size of agent's region

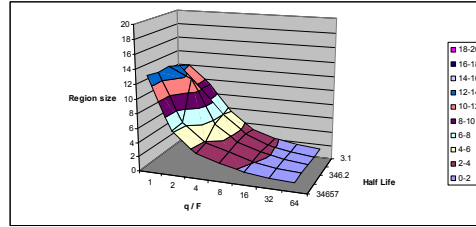

(i) Results with normal agents

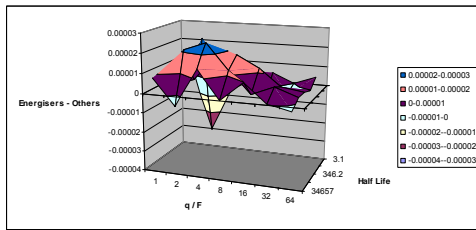

(i) Results with normal agents

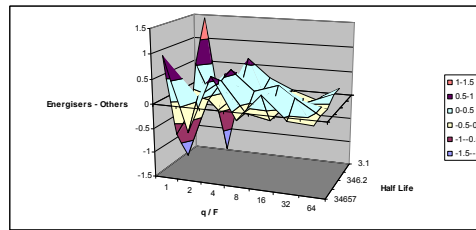

(ii) Energiser (1/6) - others

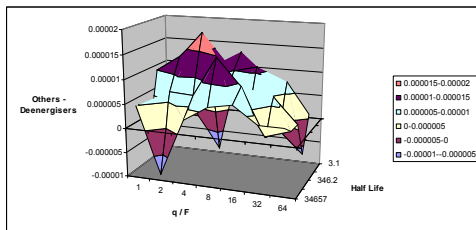

(ii) Energiser (1/6) - others

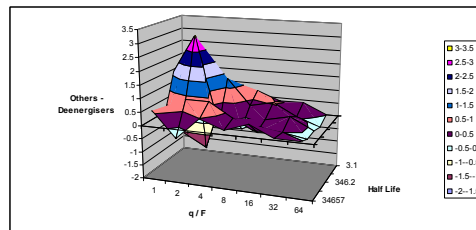

(iii) Others - De-energiser (6)

(iii) Others - De-energiser (6)

C=E, B=1 Frequency of being imitated

All agents set to normal (Energising Parameter = 1)						
		3.1	34.3	346.2	3465.4	34657
q / F	1	1.21E-05	1.26E-05	1.28E-05	1.26E-05	1.26E-05
	2	5.23E-05	3.31E-05	3.16E-05	1.85E-05	1.89E-05
	4	4.23E-05	3.25E-05	2.33E-05	1.66E-05	1.79E-05
	8	0.000023	2.12E-05	1.78E-05	1.49E-05	1.29E-05
	16	1.29E-05	1.28E-05	1.17E-05	9.56E-06	7.56E-06
	32	6.88E-06	7.13E-06	6.5E-06	5.69E-06	4.44E-06
	64	3.31E-06	2.88E-06	3.06E-06	3.94E-06	3.38E-06

Difference: Energiser (Param. = 1/6) - The Others						
		3.1	34.3	346.2	3465.4	34657
	1	0.000005	-6.1E-06	-4.6E-07	1.97E-07	8.09E-06
	2	-3E-05	2.28E-05	3.16E-06	2.1E-05	-4.9E-06
	4	-6.6E-06	-5.3E-06	1.61E-05	2.49E-05	1.44E-05
	8	-4.8E-07	7.37E-06	1.8E-05	1.24E-05	6.58E-08
	16	4.74E-06	-3.9E-06	1.16E-05	1.38E-06	9.93E-06
	32	-6.6E-06	-2.7E-06	3.42E-06	5.99E-06	5.26E-07
	64	3.82E-06	-2E-07	1.58E-06	1.78E-06	-1.8E-06

Difference: The Others - De-energiser (Param. = 6)						
		3.1	34.3	346.2	3465.4	34657
	1	-1.8E-06	3.95E-07	0.00001	-3.4E-06	4.87E-06
	2	-2E-06	4.67E-06	1.32E-05	6.97E-06	-8.7E-06
	4	-9E-06	1.05E-05	1.84E-05	6.78E-06	2.96E-06
	8	1.3E-05	9.87E-06	5.46E-06	1.48E-05	6.05E-06
	16	0	1.12E-05	3.36E-06	9.34E-06	6.91E-06
	32	7.3E-06	-2E-06	6.58E-06	-2.6E-07	3.49E-06
	64	7.24E-07	-6.4E-06	1.32E-06	1.38E-06	3.49E-06

Size of agent's region

All agents set to normal (Energising Parameter = 1)						
		3.1	34.3	346.2	3465.4	34657
	1	12.035	12.625	13.135	13	13.355
	2	9.31	9.445	11.865	6.395	6.15
	4	5.455	5.99	5.56	3.89	3.47
	8	3.105	3.475	3.295	2.935	2.56
	16	2.085	2.2	2.25	2.045	1.74
	32	1.56	1.535	1.645	1.525	1.39
	64	1.295	1.245	1.265	1.34	1.3

Difference: Energiser (Param. = 1/6) - The Others						
		3.1	34.3	346.2	3465.4	34657
	1	1.436842	0.526316	-1.35263	-0.73684	0.994737
	2	-1.47368	-0.44211	-0.08947	0.089474	-0.50526
	4	0.621053	-0.02105	0.584211	0.457895	0.657895
	8	0.226316	0.052632	0.173684	-0.14211	-0.15263
	16	0.010526	-0.10526	0.31579	-0.24737	0.389474
	32	-0.15263	-0.08421	-0.00526	0.247368	-0.06316
	64	0.121053	0.126316	-0.05789	-0.05263	-0.10526

Difference: The Others - De-energiser (Param. = 6)						
		3.1	34.3	346.2	3465.4	34657
	1	1.873684	-1.06316	1.647368	-0.06316	0.610526
	2	-0.75263	-1.54211	3.057895	0.868421	-0.34737
	4	0.194737	1.310526	-0.32632	0.863158	0.489474
	8	0.721053	0.352632	-0.31579	0.336842	0.152632
	16	0.368421	0.547368	0.121053	-0.09474	0.473684
	32	0.410526	0.073684	0.326316	0	0.057895
	64	0.015789	-0.24737	-0.11053	-0.14737	0.057895

C.3 Claims Tests

The claims tests are unchanged from those described for the agent-energy model in Appendix B.

C.3.1 Claim 1: Based on Frequency of being imitated

	3.1	34.3	346.2	3465.4	34657
1	0	1	2	0	0
2	0	1	3	0	0
4	0	0	3	0	1
8	0	0	1	0	1
16	0	0	0	0	1
32	0	0	0	0	1
64	0	0	0	1	1

(i) $B=E$

	3.1	34.3	346.2	3465.4	34657
1	0	0	0	0	0
2	0	0	0	0	0
4	0	0	0	0	0
8	0	0	0	0	0
16	0	0	0	0	0
32	0	0	0	0	0
64	0	0	0	0	0

(iii) $C=E$

	3.1	34.3	346.2	3465.4	34657
1	0	0	0	0	0
2	0	0	0	0	0
4	0	0	1	0	1
8	0	0	0	0	1
16	0	0	0	1	1
32	0	0	0	0	0
64	0	0	0	0	0

(ii) $B=E, C=I$

	3.1	34.3	346.2	3465.4	34657
1	0	0	0	0	0
2	0	0	0	0	0
4	0	0	0	0	0
8	0	0	0	0	0
16	0	0	0	0	0
32	0	0	0	0	0
64	0	0	0	0	1

(iv) $C=E, B=I$

C.3.2 Other claims tests

For claim 2 - based on the output metric Size of agent's region - we were unable to obtain any points where a non-zero score was achieved at either 95% or 80% confidence level.

For claim 3 - based on population fitness improvement - we had just one point at 80% confidence interval: De-energisers beat Normal agents at (HL = 34.3, $q/F = 4$) for $C=E$.

Appendix D Results with the Interaction Ritual Agents

Model (IRAM)

D.1 Introduction

We collate in this appendix the results of all experiments performed with the Interaction Ritual Agents Model (IRAM) in Chapter 10. The model was described in Chapter 6.

For the IRAM we have results for two scenarios, distinguished by their payoff function components (Table 17). See 6.6 and 6.7 for the definitions of the payoff function components, Belongingness and Competence, and the use of the energising parameter. We ran 138 replications for B=E and 80 for B=E, C=1. We also performed the claims tests for B=E with 40 replications to see what difference it made.

Table 17 IRAM scenarios explained

Code	Explanation
B=E	Payoffs based on Belongingness. Energising alters Belongingness
B=E, C=1	Payoffs based on Belongingness and Competence. Energising alters Belongingness

D.2 IRAM behaviour

The charts are as described for the agent-energy model in Appendix B.

D.2.1 Payoff: Belongingness; Energising: Belongingness (B=E)

(a) Frequency of being imitated

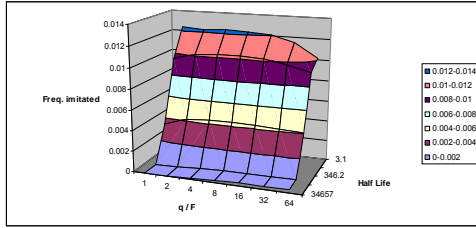

(b) Size of agent's region

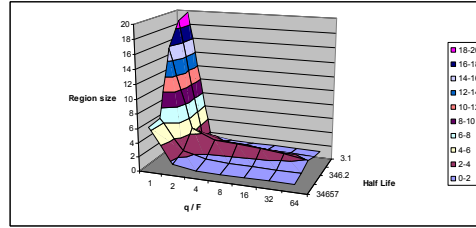

(i) Results with normal agents

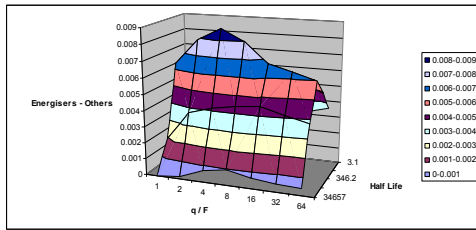

(i) Results with normal agents

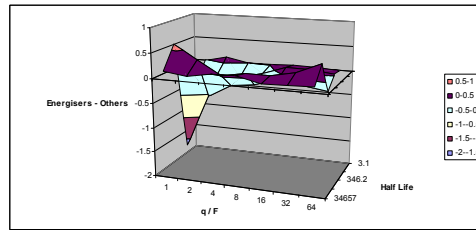

(ii) Energiser (1/6) - others

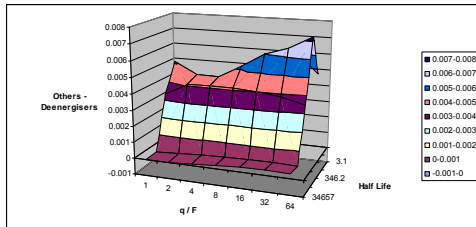

(ii) Energiser (1/6) - others

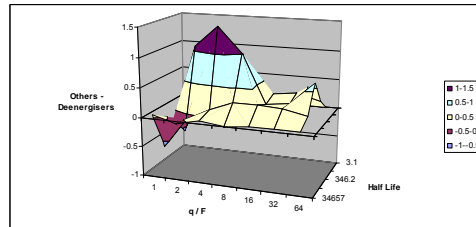

(iii) Others - De-energiser (6)

B=E Frequency of being imitated

All agents set to normal (Energising Parameter = 1)

		Half life				
		3.1	34.3	346.2	3465.4	34657
q / F	1	0.012354	0.009575	0.003409	1.89E-05	6.21E-07
	2	0.012179	0.010149	0.004181	7.29E-05	2.86E-05
	4	0.012328	0.010258	0.004324	0.000186	8.79E-05
	8	0.012271	0.01027	0.004351	0.000272	0.000204
	16	0.012062	0.010153	0.004265	0.000321	0.000288
	32	0.011533	0.009796	0.004182	0.000347	0.000302
	64	0.010147	0.009226	0.004051	0.000363	0.000294

Difference: Energiser (Param. = 1/6) - The Others

		Half life				
		3.1	34.3	346.2	3465.4	34657
1	1	0.002707	0.002497	0.006336	0.0019	1.09E-05
2	2	0.003972	0.005232	0.007888	0.003714	0.000141
4	4	0.003153	0.005799	0.008683	0.004143	0.000727
8	8	0.002997	0.006135	0.007986	0.004353	0.000992
16	16	0.002853	0.005219	0.006732	0.004508	0.000674
32	32	0.003145	0.005479	0.006373	0.004118	0.000508
64	64	0.003504	0.004848	0.005954	0.003809	0.00045

Difference: The Others - De-energiser (Param. = 6)

		Half life				
		3.1	34.3	346.2	3465.4	34657
1	1	-0.00038	0.005116	0.003351	9.57E-06	5.91E-07
2	2	0.001772	0.004376	0.004075	6.11E-05	2.92E-05
4	4	0.002034	0.004367	0.004104	0.000166	9.24E-05
8	8	0.004582	0.005145	0.004109	0.000195	0.000212
16	16	0.004983	0.005995	0.004006	0.000223	0.000304
32	32	0.00598	0.006493	0.003808	0.000263	0.00032
64	64	0.004694	0.007231	0.003443	0.000195	0.000279

Size of agent's region

All agents set to normal (Energising Parameter = 1)

		Half life				
		3.1	34.3	346.2	3465.4	34657
1	1	19.74275	19.01449	15.73333	6.653623	6.374638
2	2	1.557971	2.907246	4.571739	2.405797	1.592754
4	4	1.126812	2.018116	3.248551	1.572464	1.093478
8	8	1.051799	1.865468	3.083453	1.431655	1.031655
16	16	1.028058	1.502878	2.835252	1.369065	1.045324
32	32	1.019424	1.459712	2.442446	1.317986	1.077698
64	64	1.020863	1.356835	1.951079	1.308633	1.05036

Difference: Energiser (Param. = 1/6) - The Others

		Half life				
		3.1	34.3	346.2	3465.4	34657
1	1	-0.01449	-0.36766	-1.63844	0.601831	0.167048
2	2	0.094584	-0.17086	-0.52937	0.331045	0.09611
4	4	0.001526	-0.20976	-0.26011	0.055683	0.180778
8	8	0.005339	-0.07933	-0.209	0.129672	0.19222
16	16	0.030292	0.074214	-0.05377	0.134797	0.086331
32	32	0.012874	0.069671	-0.13101	0.226429	0.093904
64	64	-0.00606	0.021961	-0.20825	0.437713	0.113593

Difference: The Others - De-energiser (Param. = 6)

		Half life				
		3.1	34.3	346.2	3465.4	34657
1	1	-0.15713	-0.57818	-0.2868	-0.60412	0.061785
2	2	0.050343	0.305111	1.090008	-0.07857	-0.03738
4	4	-0.03127	0.302059	1.440885	0.128146	0.046529
8	8	-0.02196	0.44983	1.019311	0.273381	-0.00303
16	16	-0.00454	0.258236	0.189322	0.277925	0.034835
32	32	-0.00303	0.308974	0.239303	0.260507	0.042408
64	64	-0.00606	0.213555	0.614161	0.182507	0.046952

D.2.2 Payoff: Belongingness & Competence; Energising: Belongingness

(B=E, C=1)

(a) Frequency of being imitated

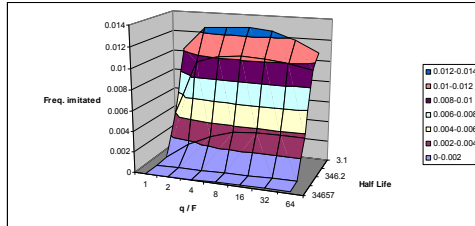

(i) Results with normal agents

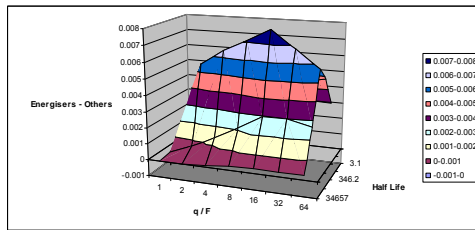

(ii) Energiser (1/6) - others

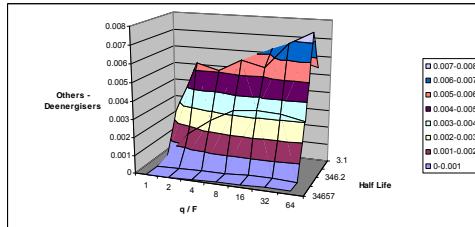

(iii) Others - De-energiser (6)

B=E, C=1 Frequency of being imitated

All agents set to normal (Energising Parameter = 1)

		Half life				
		3.1	34.3	346.2	3465.4	34657
q / F	1	0.010225	0.003996	3.46E-05	8.14E-06	1.35E-05
	2	0.012481	0.009465	0.001649	3.55E-05	2.82E-05
	4	0.012651	0.010165	0.002725	7.91E-05	5.69E-05
	8	0.012795	0.010403	0.003443	0.000136	0.000103
	16	0.012525	0.010236	0.003614	0.000186	0.000149
	32	0.011825	0.009963	0.003631	0.000233	0.000173
	64	0.010718	0.009505	0.003591	0.00026	0.000185

Difference: Energiser (Param. = 1/6) - The Others

		Half life				
		3.1	34.3	346.2	3465.4	34657
1	1	0.001777	0.001212	0.000619	9.68E-05	-2.3E-07
2	1	0.002739	0.002425	0.005484	0.000651	2.76E-05
4	1	0.004313	0.004372	0.006392	0.00134	0.000108
8	1	0.001132	0.004488	0.007109	0.002118	0.000247
16	1	0.003995	0.005085	0.007859	0.002968	0.000293
32	1	0.00295	0.004549	0.006788	0.002983	0.00027
64	1	0.002933	0.004798	0.005721	0.002645	0.000279

Difference: The Others - De-energiser (Param. = 6)

		Half life				
		3.1	34.3	346.2	3465.4	34657
1	1	0.002716	0.002445	3.05E-05	1.28E-06	6.89E-06
2	1	0.001869	0.00537	0.001602	3.03E-05	2.73E-05
4	1	0.002214	0.005067	0.002562	6.83E-05	5.74E-05
8	1	0.005277	0.005745	0.003234	0.000105	0.000103
16	1	0.006242	0.005426	0.003355	0.000164	0.000141
32	1	0.00573	0.006863	0.003317	0.000186	0.000179
64	1	0.005358	0.007536	0.003041	0.000138	0.000183

(b) Size of agent's region

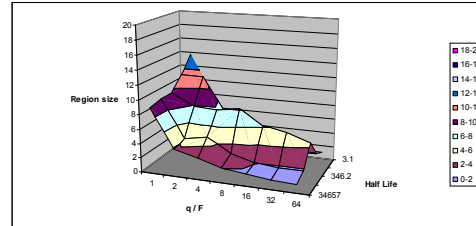

(i) Results with normal agents

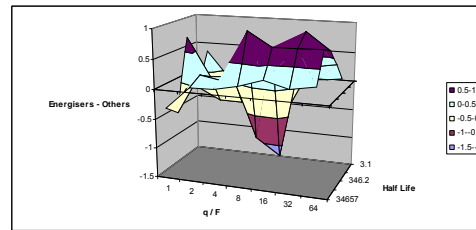

(ii) Energiser (1/6) - others

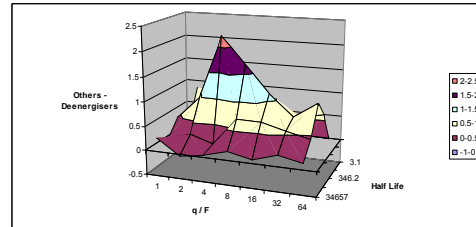

(iii) Others - De-energiser (6)

All agents set to normal (Energising Parameter = 1)

Size of agent's region

		Half life				
		3.1	34.3	346.2	3465.4	34657
1	1	13.67125	11.3675	9.57	9.505	9.10375
2	1	2.06	11.335	7.8875	4.2175	3.7725
4	1	1.25125	6.38375	7.6775	4.80625	3.0075
8	1	1.08	3.58125	8.19375	2.8925	2.0375
16	1	1.03125	2.395	6.16125	2.05	1.69625
32	1	1.02125	1.8	5.5775	1.7675	1.285
64	1	1.02	1.87375	4.4575	1.76	1.14375

Difference: Energiser (Param. = 1/6) - The Others

		Half life				
		3.1	34.3	346.2	3465.4	34657
1	1	0.343421	-0.23947	0.731579	-0.48421	-0.29079
2	1	-0.11974	-0.42895	0.084211	0.193421	0.077632
4	1	-0.13421	-0.43026	0.115789	0.134211	0.086842
8	1	0.002632	-0.26184	-0.91447	0.977632	1.176316
16	1	0.005263	-0.45658	-1.17763	0.742105	0.307895
32	1	-0.01842	0.294737	0.944737	0.748684	0.203947
64	1	0.026316	0.360526	0.667105	0.757895	0.267105

Difference: The Others - De-energiser (Param. = 6)

		Half life				
		3.1	34.3	346.2	3465.4	34657
1	1	0.826316	0.009211	0.440789	0.118421	0.292105
2	1	-0.11053	0.971053	0.913158	0.272368	-0.03026
4	1	0.068421	-0.20658	2.210526	0.119737	0.043421
8	1	0.038158	1	1.675	0.689474	0.178947
16	1	0.023684	0.097368	1.127632	0.684211	0.073684
32	1	0.002632	0.548684	0.701316	0.547368	0.228947
64	1	-0.00395	0.648684	1.023684	0.447368	0.131579

D.3 Claims Tests

The claims tests are unchanged from those described for the agent-energy model in Appendix B. Confidence levels used are 95% for claim 1, and 80% for claims 2 and 3.

D.3.1 Claim 1: Based on Frequency of being imitated

	3.1	34.3	346.2	3465.4	34657
1	0	3	3	2	1
2	3	3	3	3	3
4	1	3	3	3	3
8	3	3	3	3	3
16	1	3	3	3	3
32	3	3	3	3	3
64	1	3	3	3	3

(i) $B=E$, 138 replications

	3.1	34.3	346.2	3465.4	34657
1	1	1	2	0	0
2	2	3	3	2	3
4	0	3	3	3	3
8	1	3	3	3	3
16	3	3	3	3	3
32	1	3	3	3	3
64	0	3	3	3	3

(iii) $B=E$, $C=I$

	3.1	34.3	346.2	3465.4	34657
1	0	3	3	2	1
2	0	3	3	3	0
4	0	3	3	3	3
8	1	3	3	3	3
16	1	3	3	3	3
32	0	3	3	3	3
64	0	3	3	3	3

(ii) $B=E$, 40 replications

D.3.2 Other claims tests

In the results for claim 2, note the difference made by running more replications for $B=E$.

	3.1	34.3	346.2	3465.4	34657
1	0	0	0	0	0
2	0	0	0	0	0
4	0	0	0	0	0
8	0	0	0	1	0
16	0	0	0	1	0
32	0	1	0	1	0
64	0	0	1	3	1

(i) $B=E$, 138 replications

	3.1	34.3	346.2	3465.4	34657
1	0	0	0	0	0
2	0	0	0	0	0
4	0	0	0	0	0
8	0	0	0	0	0
16	0	0	0	0	0
32	0	0	0	1	0
64	0	0	0	0	0

(iii) $B=E$, $C=1$

	3.1	34.3	346.2	3465.4	34657
1	0	0	0	0	0
2	0	0	0	0	0
4	0	0	0	0	0
8	0	0	0	0	0
16	0	0	0	0	0
32	0	0	0	1	0
64	0	0	0	0	0

(ii) $B=E$, 40 replications

For claim 3 - based on population fitness improvement - we had just two points at 80% confidence interval: Normal agents beat De-energisers at (HL = 34.3, $q/F = 64$) and (HL = 34657, $q/F = 64$) for $B=E$, $C=1$.

Appendix E Results with the IR Memory Model (IRM model)

E.1 Introduction

We collate in this appendix the results of all experiments performed with the IR Memory model (IRM) in 10.4. The model was described in Chapter 6.

We have eight scenarios for the IRM model. They use the B=E payoff scenario, but vary in the size of the IR Memory, m . See 6.6 and 6.7 for the definitions of the payoff function component, Belongingness, and the use of the energising parameter. 40 simulation replications were run for each scenario with the IRM model.

E.2 IRM model behaviour

To the parameter ranges used by the charts in appendix C we add memory size, m .

E.2.1 Frequency of being imitated - by memory size (m)

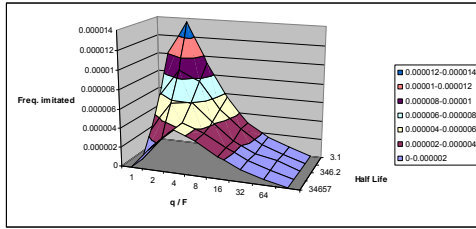

$m=1$

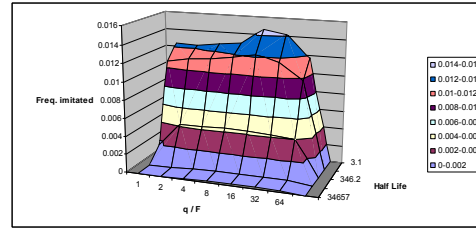

$m=5$

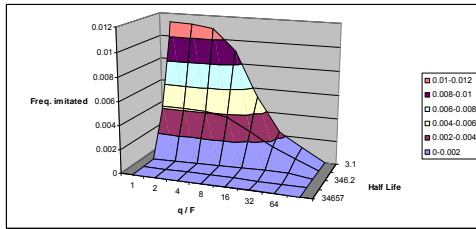

$m=2$

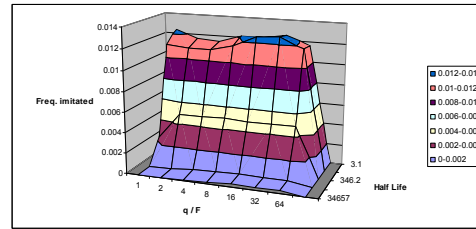

$m=6$

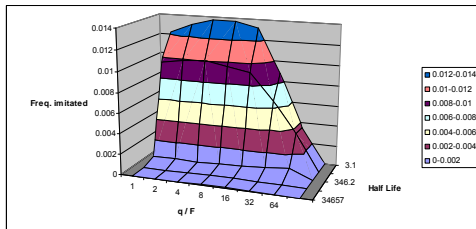

$m=3$

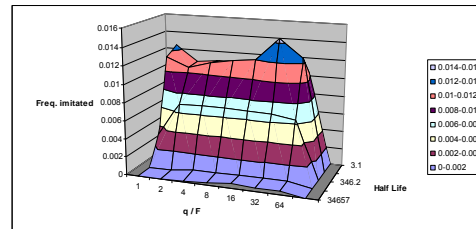

$m=7$

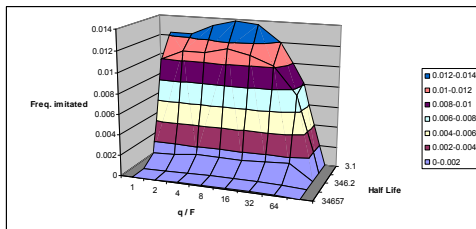

$m=4$

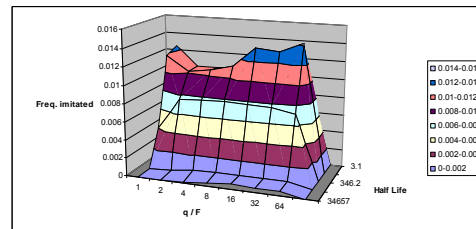

$m=8$

E.2.2 Size of agent's region - by memory size (m)

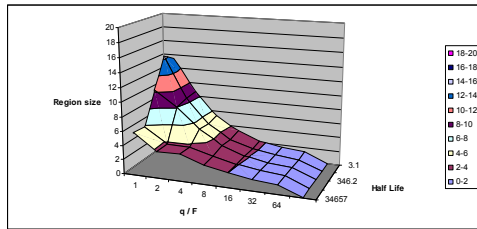

$m=1$

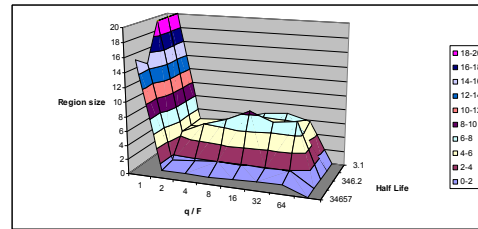

$m=5$

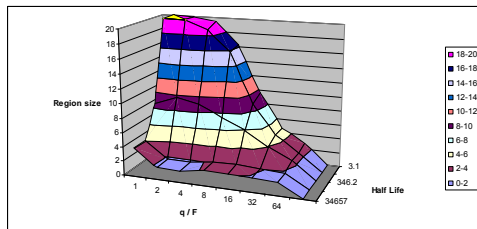

$m=2$

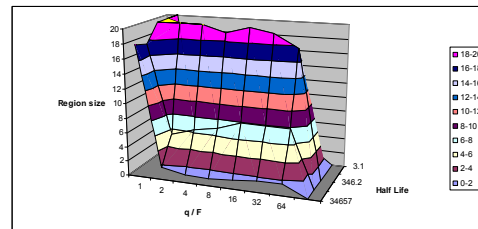

$m=6$

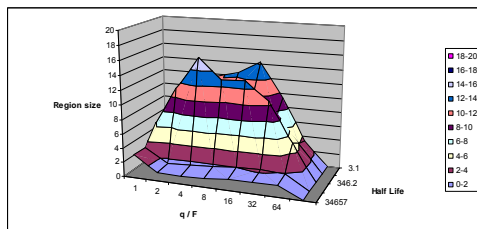

$m=3$

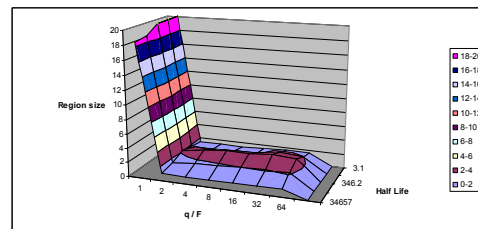

$m=7$

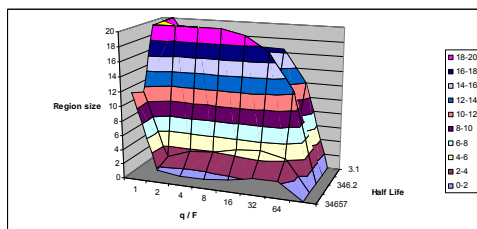

$m=4$

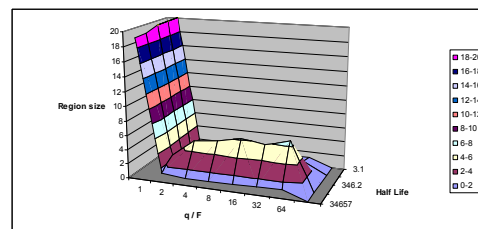

$m=8$

E.2.3 Frequency of being imitated - by half life

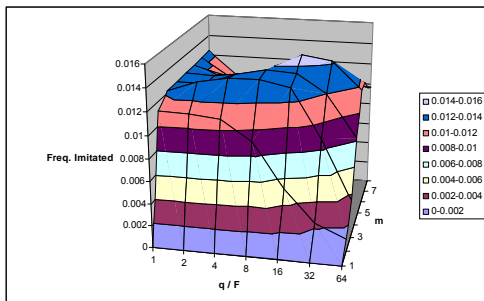

(i) Decay = 0.8; Half Life = 3.1

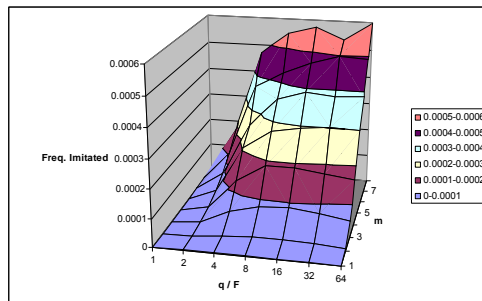

(iv) Decay = 0.9998; Half Life = 3465.7

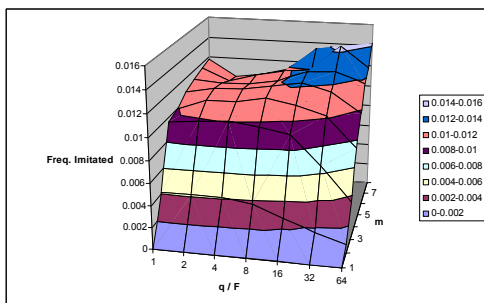

(ii) Decay = 0.98; Half Life = 34.6

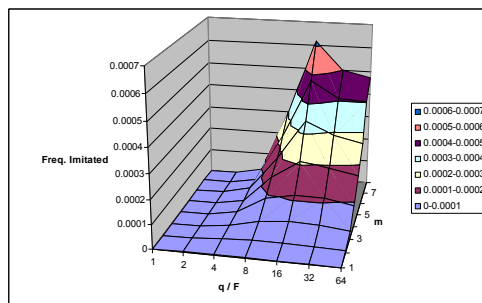

(v) Decay = 0.99998; Half Life = 34657.3

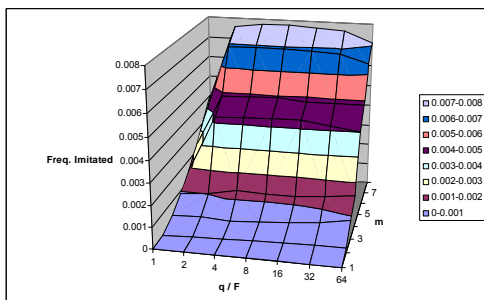

(iii) Decay = 0.998; Half Life = 346.5

E.2.4 Size of agent's region - by half life

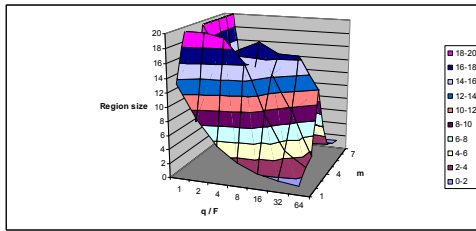

(i) Decay = 0.8; Half Life = 3.1

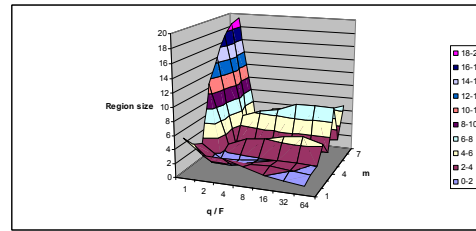

(iv) Decay = 0.9998; Half Life = 3465.7

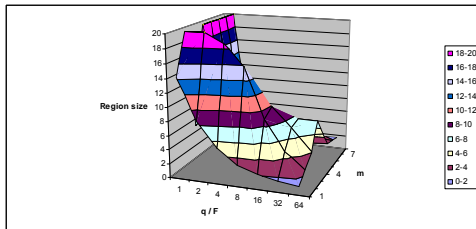

(ii) Decay = 0.98; Half Life = 34.6

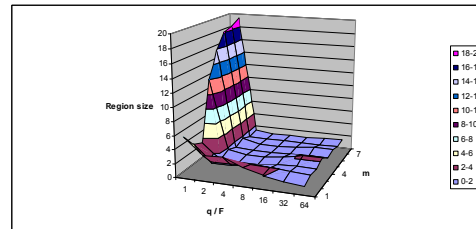

(v) Decay = 0.99998; Half Life = 34657.3

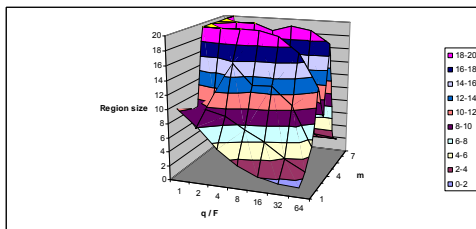

(iii) Decay = 0.998; Half Life = 346.5

E.2.5 Frequency of being imitated - by (q / F)

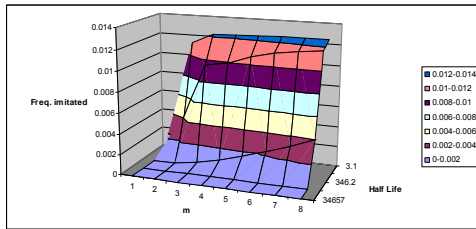

(i) (q/F) = 1

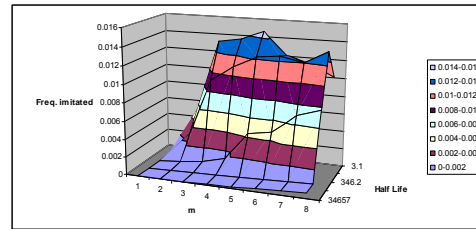

(v) (q/F) = 16

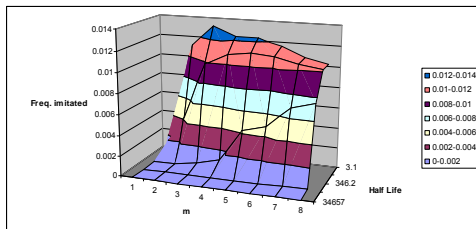

(ii) (q/F) = 2

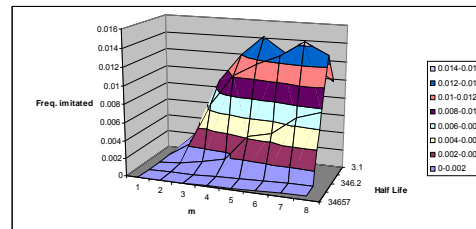

(vi) (q/F) = 32

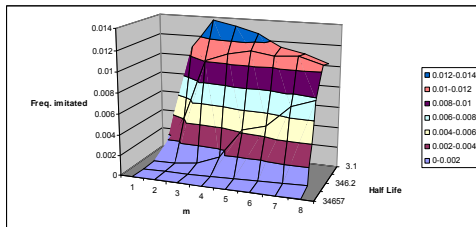

(iii) (q/F) = 4

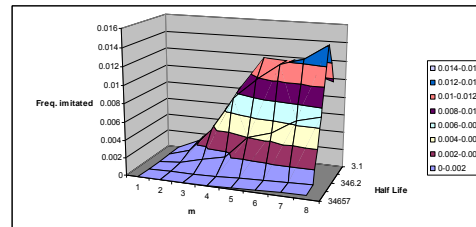

(vii) (q/F) = 64

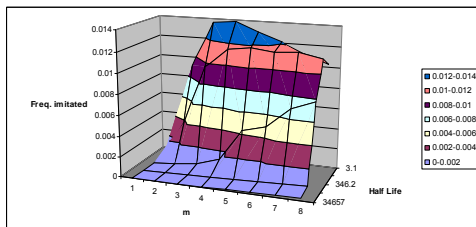

(iv) (q/F) = 8

E.2.6 Size of agent's region - by (q/F)

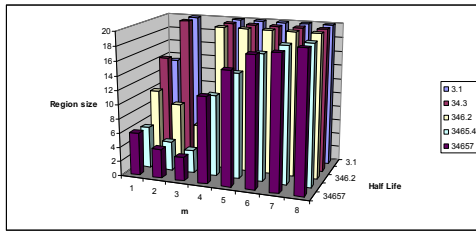

(i) (q/F) = 1

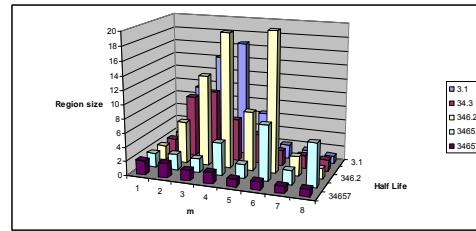

(v) (q/F) = 16

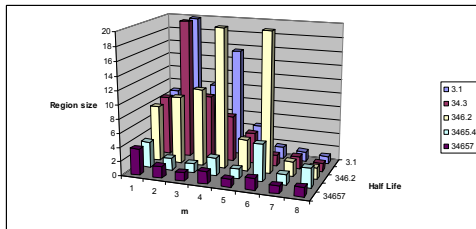

(ii) (q/F) = 2

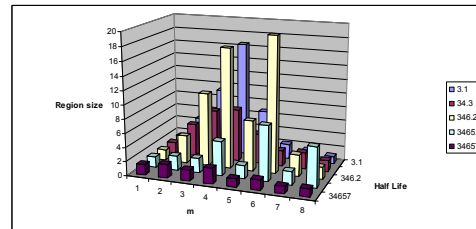

(vi) (q/F) = 32

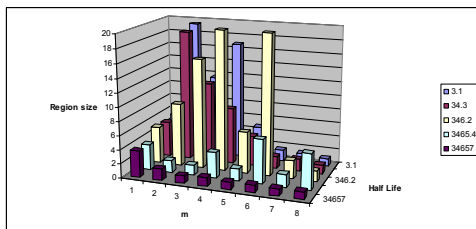

(iii) (q/F) = 4

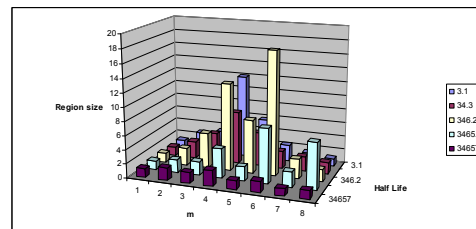

(vii) (q/F) = 64

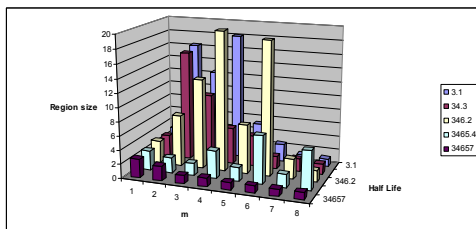

(iv) (q/F) = 8

E.3 Claims Tests

The claims tests are unchanged from those described for the agent-energy model in appendix C. Confidence levels used are 95% for claim 1, and 80% for claim 2. With no scenario including a Competence component in the payoff, claim 3 is not relevant here.

E.3.1 Claim 1: Based on Frequency of being imitated

	3.1	34.3	346.2	3465.4	34657
1	0	1	3	0	0
2	0	1	3	3	3
4	0	1	3	3	3
8	0	0	1	3	3
16	0	0	1	3	3
32	0	0	1	1	1
64	0	0	0	1	1

$m=1$

	3.1	34.3	346.2	3465.4	34657
1	1	3	3	0	0
2	1	3	3	3	0
4	0	3	3	3	3
8	0	1	3	3	3
16	0	1	3	3	3
32	0	1	3	3	3
64	0	1	3	3	3

$m=5$

	3.1	34.3	346.2	3465.4	34657
1	3	3	3	0	0
2	3	3	3	3	3
4	1	3	3	3	3
8	0	3	3	3	3
16	0	3	3	3	3
32	0	1	3	3	3
64	0	0	3	3	3

$m=2$

	3.1	34.3	346.2	3465.4	34657
1	1	3	3	2	0
2	0	3	3	3	0
4	0	1	3	3	3
8	0	1	3	3	3
16	0	1	3	3	3
32	0	1	3	3	3
64	0	1	3	3	3

$m=6$

	3.1	34.3	346.2	3465.4	34657
1	3	3	3	0	0
2	0	3	3	3	2
4	0	3	3	3	3
8	0	3	3	3	3
16	0	1	3	3	3
32	0	1	3	3	3
64	0	1	3	3	3

$m=3$

	3.1	34.3	346.2	3465.4	34657
1	1	3	3	2	0
2	1	3	3	3	0
4	0	1	3	3	3
8	0	1	3	3	3
16	0	1	3	3	3
32	0	1	3	3	3
64	0	1	3	3	3

$m=7$

	3.1	34.3	346.2	3465.4	34657
1	3	3	3	0	0
2	1	3	3	3	1
4	0	1	3	3	3
8	0	1	3	3	3
16	0	1	3	3	3
32	0	1	3	3	3
64	0	1	3	3	3

$m=4$

	3.1	34.3	346.2	3465.4	34657
1	1	3	3	2	0
2	0	3	3	3	0
4	0	1	3	3	3
8	0	1	3	3	3
16	0	1	3	3	3
32	0	1	3	3	3
64	0	1	3	3	3

$m=8$

E.3.2 Claim 2: Based on Size of agent's region

	3.1	34.3	346.2	3465.4	34657
1	0	0	0	0	0
2	0	0	0	2	0
4	0	0	0	0	0
8	0	0	0	0	0
16	0	0	0	0	0
32	0	0	0	0	0
64	0	0	0	0	0

$m=1$

	3.1	34.3	346.2	3465.4	34657
1	0	0	0	0	0
2	0	0	0	0	0
4	0	0	0	0	0
8	0	0	0	0	0
16	0	0	0	0	0
32	0	0	0	0	0
64	0	0	0	0	0

$m=5$

	3.1	34.3	346.2	3465.4	34657
1	0	0	0	0	0
2	0	0	0	0	0
4	0	0	0	2	0
8	0	0	0	2	0
16	0	0	0	2	0
32	0	0	0	0	0
64	0	0	0	0	0

$m=2$

	3.1	34.3	346.2	3465.4	34657
1	0	0	0	0	0
2	0	0	0	0	0
4	0	0	0	0	0
8	0	0	0	0	3
16	0	0	0	0	2
32	0	0	0	0	2
64	0	0	0	0	2

$m=6$

	3.1	34.3	346.2	3465.4	34657
1	0	0	0	0	0
2	0	0	0	0	0
4	0	0	0	0	0
8	0	0	0	0	0
16	0	0	0	0	2
32	0	0	0	0	0
64	0	0	0	2	0

$m=3$

	3.1	34.3	346.2	3465.4	34657
1	0	0	0	0	0
2	0	0	0	0	0
4	0	0	0	0	0
8	0	0	0	0	0
16	0	0	0	0	0
32	0	0	0	0	0
64	0	0	0	0	0

$m=7$

	3.1	34.3	346.2	3465.4	34657
1	0	0	0	0	0
2	0	0	0	0	0
4	0	0	0	0	0
8	0	0	0	0	0
16	0	0	0	0	2
32	0	0	0	0	2
64	0	0	0	0	2

$m=4$

	3.1	34.3	346.2	3465.4	34657
1	0	0	0	0	0
2	0	0	0	0	0
4	0	0	0	0	0
8	0	0	0	0	0
16	0	0	0	0	0
32	0	0	0	0	0
64	0	0	0	0	0

$m=8$

Appendix F The world of “Homo Sociologicus”

F.1 Introduction

If interaction rituals and emotional energy are the solution, what is the problem? Why has evolution by natural selection produced human agents with a preference for group solidarity? As noted in Chapter 6, the design of the Interaction Ritual Agents Model (IRAM) owes something to various heuristic search algorithms. In this section we spell out the analogies, and make suggestions – based on experience of optimisation systems – as to what the presence of these analogous features implies for the nature of the environment faced by human agents.

This is not to suggest that sociologists can teach optimisation experts new tricks. Heuristic search algorithms have been based upon ideas drawn from natural sciences - one thinks of Genetic Algorithms, Ant Colony Optimisation, and Simulated Annealing among other techniques (Mitchell, 1996; Corne et al, 1999; Kirkpatrick et al, 1983) - but improvements to the original algorithms have invariably taken them away from the biological and physical metaphors they started with. An agent-based model based on Interaction Ritual theory is not guaranteed to perform well at solving any of the combinatorial optimisation problems usually tackled with heuristic search. Indeed, by the “no-free-lunch theorem” we know that no heuristic can perform well at anything other than a minority of problem types (Wolpert & Macready, 1997). But where an IRAM performs particularly badly we have the opportunity to ask questions in two directions, one revising our picture of sociological agents, the other revising

our picture of their environment. Firstly, are human agents actually solving problems in a different way? Secondly, are the problem environments of human agents different to the optimisation problems studied? In both cases, if there are differences, what are they?

We are not the first to attempt to draw analogies between social agents and optimisation heuristics. Inspired by Particle Swarm Optimisation (PSO), Kennedy (1998) created a discrete-variable optimisation system by adding a fitness function and preference for fitness to the Axelrod Cultural Model (ACM). The principles behind Stochastic Diffusion Search (SDS) are illustrated by reference to a number of human agents trying out different dishes at different restaurants each night and comparing experiences through social interactions the following day (Bishop, 1989; De Meyer et al, 2003). Wolpert (2004) finds parallels between an optimisation system, Probability Collectives (PC) or Product Distributions, on the one hand, and on the other both statistical physics (mean field theory) and advanced game theory used in recent economics. Our extensions beyond the ACM were detailed in chapter 5. The “agents” in both SDS and PC are much simpler in the information they individually store, or the decisions they make - each agent being represented by a single variable. The IRAM has many more features than these, but is also much closer to sociological theory in its depiction of agents. Indeed, it represents the first attempt we know of to focus on emotional energy and the theory of Interaction Rituals in drawing the analogies.

F.2 Social interaction and agent memory

The IRAM has a population of solutions, but organises them in two different ways - socially and as memories. Like Genetic Algorithms (GA) it can pursue in parallel multiple routes to different fitness peaks (Mitchell, 1996). By constructing new solutions using information from two interaction ritual participants the IRAM has the ability to test solutions lying between two existing solutions on the landscape. It is believed the analogous process in GA - “cross over” - greatly speeds up exploration of the landscape compared to a simpler heuristic like Descent, or Hill Climbing (Mitchell, 1996, p.171-3; Mackay, 2003, chapter 19). In both PSO and the IRAM different particles / agents exploring the landscape in parallel influence each other - in the case of PSO through a force of attraction towards particles with good solutions, in the case of the IRAM through imitation when a better solution has been constructed.

But whereas particles in PSO memorise just one solution at a time - or even delegate memory of good solutions to a separate class of particles (Clerc, 2006, chapter 7) - in the IRAM agents can have multiple solutions in their IR Memory. As in Harmony Search (Geem et al, 2001), this memory is sampled from to construct just one new solution which then replaces one row of memory if fit enough.

The heuristic use of a memory of limited size was present in the LO Model of social network formation (Pujol et al, 2005). Bounded rational agents, unable to consider every possible interaction partner, planned new interactions from a limited subset of previous experienced partners. The IRAM goes further. IR Memories include combinations of past participants with cultural objects such as activities performed and places performed in. Evaluation of all combinations experienced would become infeasible computationally - to say nothing of evaluation of all possible combinations

(q^F of them). Agents in the IRAM use a heuristic search algorithm on a problem space that is both social and cultural - the space of interaction ritual possibilities.

Possession of the IR Memory also enables an agent to solve problems heuristically in social isolation - a useful ability in cases where social interaction may become infrequent or costly. Collins (1998) notes intellectuals' ability to work in isolation using the cultural capital of past IR events - to seek social coalitions with the great minds of the past. Dennett (1991, 1997) argues that our minds produce multiple drafts before executing a decision. Having agents able to solve problems both individually and socially makes the IRAM doubly suitable for research into the possibility of distributed / de-centralised multi-agent systems (Wolpert et al, 1999) - problem-solving robot devices that can solve as yet unobserved types of problems in environments beyond our more direct control, such as in outer space and cyberspace (Bieniawski & Wolpert, 2004).

One avenue for future research, however, is how best to organise the population of solutions - among many agents of small IR Memory, or fewer agents with more memories. Where does the ideal balance between N and m lie for various classes of problem?

Another important issue is how best to maintain some level of diversity within the IR Memory. m copies of the same solution are unlikely to be m -times better than one, but without some sort of diversity preservation rules an agent's IR Memory can converge on uniformity all too easily. To this end we adopted one particular pair of sampling and updating methods for the IR Memory model and the IRAM, but plenty of other

possibilities may exist in the heuristic search literature, since analogous problems (“premature convergence”) can affect other algorithms.

F.3 Energy decay, Expected Gain and innovation

Limited memory space means agents must replace old solutions if new ones are to be remembered. The presence of a decay process affects this replacement in two ways. Firstly, by creating a difference - evaluated as Expected Gain - between original energy payoff associated with the IR event and the current energy charge on the memory of it, we can stratify sampling by this to raise the chance of old information being retested before it expires. Secondly, if the tests fail successively the old information will be replaced - even by IR experiences that yield lower payoffs if those beat the decayed charge. So if a fitness landscape is changing over time, our agents are able to “forget” past solutions that were fit at the time but would distort the construction of new solutions now.

A question when given a particular type of dynamically changing problems would be what the ideal rate of decay is. Fast decay raises the chance of information being replaced. Slow decay means new solutions will have to be fairly close in fitness to previous ones to be remembered.

Another issue with decay comes if we use energy levels to control the process of innovation in the IRAM. Although not explored in the experiments the IRAM has the capability to sample any participant or cultural trait, by giving every participant and trait a minimum level of Expected Gain. These minima are usually much lower than

energy payoffs, so an agent engaging in frequently energising IR events will be unlikely to sample using these extra Expected Gain values. But if the Expected Gain derived from IR Memories becomes poor, the chances increase of its information being ignored in favour of some other participant or trait. Fast decay will speed the growth of Expected Gain. Slow decay will leave it closer to the minima. This is not the only way to introduce innovation to a model - GA uses "Mutation" (Mitchell, 1996), HS uses "Pitch Adjustment" (Geem et al, 2001) - and the use of Expected Gain rather than current Energy Charge or original payoff for stratified sampling should be evaluated for given problem sets.

But there is likely to be some sort of relation between emotional energy and innovation in social agents. Studies of creative individuals suggest uses of an energy concept in association with confidence (Clark, K, 1969). Confidence in one's ability to create successful solutions may allow one to propose new ones publicly, despite the risk of their breaking constraints. Energy dynamics can affect the balance between exploration and exploitation - a balance identified in March's model of organisational learning and adjusted by "Temperature" control in Probability Collectives (Bieniawski & Wolpert, 2004b) and Simulated Annealing (Kirkpatrick et al, 1983). Strategic use of charismatic energisers may enable an organisation to alter energy levels - and thereby the balance between creativity and conservatism - in a meta-heuristic approach to dynamic problem solving.

F.4 Autonomy, dominance and stratification

In the IRAM the Autonomy component in payoffs was based on who supplies most of the solution. High energy individuals had better chance of dominating interactions, and hence obtaining higher energy payoffs through this component. Thus Autonomy should allow the emergence of stratification within the population, including group leaders who dominate their groups. But reducing the payoffs for the dominated members will induce peripheral members to consider joining other groups. This may provide a way in which group size is balanced off against other determinants of payoff - Competence and Belongingness - and thus an IRAM population may control its own allocation of agent resources to searching in particular parts of a landscape.

In addition, Autonomy can make unstable the situation in which two high-energy rivals attempt to occupy the same point on the landscape. They may dominate others, but they cannot dominate each other simultaneously. One will find the encounter falls short of expectations, leading to lower energy. Thus there may be repulsion effects in the IRAM similar to those used in PSO to prevent duplication of particular solutions (Blackwell & Branke, 2006).

In the experiments conducted with the agent-energy model we found clear results harder to come by with payoff functions based on Autonomy and so neglected it after Chapter 8. Detailed experiments with Autonomy and other methods of producing social stratification must lie in the future.

F.5 Groups and Belongingness

Perhaps the most puzzling aspect of social agents as problem solvers is their enjoyment of similarity, or sense of Belongingness as modelled in the IRAM. Given a choice between a fit solution and a socially popular one, why would a (boundedly) rational agent do better with the latter, materially more expensive one? SDS, PSO and Ant Colony Optimisation all model social influence processes between their agents, but why would an agent prefer information from a similar agent - i.e. from one with a solution close to its own position on the fitness landscape? For a given fitness function this can be explored in the IRAM by testing different weightings of Belongingness - based on similarity between IR participants - and Competence - based on the fitness value itself. If performance is best when Belongingness is not used at all, then a crucial aspect of the theory behind the energy models is missing. Yet there is much agreement on the importance of some sort of preference for similarity or matching, including: the social exchange theorists cited by Axelrod (1997a, p.151; 1997b); Collins in his discussion of emotional energy as being generated by mutual awareness of common focus of attention (Collins, 2004, chapter 2), and; Ryan and Deci's relation of intrinsic motivation to a sense of relatedness (Ryan & Deci, 2000) - or in Quinn's interpretation of it, belongingness (Quinn, 2007).

Advocates of Stochastic Diffusion Search give one explanation - there is safety in numbers. Given a problem with a stochastic element, an individual agent may struggle to sample sufficient replications of a solution to assess it reliably. By paying attention to a group clustering around a particular solution, an agent has a better impression of the expected value of the solution.

An analogous answer for deterministic problems may lie in the concept of a “rugged” fitness landscape (Kauffman, 1993, chapter 2). If distant solutions are much less likely than close ones to resemble a current position in fitness value, then there is less risk involved in exploring more local points on the landscape. When a heuristic search algorithm generates novel solutions there is an opportunity cost when those solutions turn out to be poor, and in GA without some preservation principle there is a chance that good solutions will be lost through not being selected for the next generation. But exploration can be much more costly given real-world problems. Humans cannot experiment in the same way as computers. So by preferring to stay close to a group whose members have already tested much of the local solution space, an agent may be reducing the risk of innovating too far. Indeed, as Burt (2005, chapter 4) notes, the problem is more that groups are too successful in hindering innovation. Closed groups indulge in group think. Innovations invariably come from those with contacts to other groups - the “boundary spanners” or brokers. Again we find a trade off between exploration and exploitation, this time in the network evolution between brokerage and closure.

Closed, cliquish groups are good at preserving their cultural practices. Where agents are highly interdependent radical actions may carry a high risk of damaging the group’s members individually as well as undermining their sense of group solidarity. As Kauffman’s studies of NK fitness networks suggests (Kauffman, 1993, chapter 2) systems with high numbers of interdependencies yield more rugged landscapes that are harder to explore, and lead to highly disordered states as the system attempts to explore them. By reducing the cultural diversity amongst a group’s members, the

preference for similarity makes group membership practically easier by reducing interpersonal conflicts.

Consideration of the use of multi-swarm PSO (Blackwell & Branke, 2006) suggests a group performs well when landscapes are dynamically changing. A cluster exploring around a locale can track a peak as it shifts its position. More difficult is a landscape in which peaks alter their relative heights. A cluster of agents can find themselves focussed on a now inferior locale, and distant from the new global optimum. We have already noted the capability of agents with energy to lose confidence in solutions when they cease to satisfy. If a preference for similarity has produced the cultural group formation familiar from the ACM, then there may have been preserved in the population a number of rival groups clustered around different peaks, and thus a variety of starting points given new need to search. Being stuck in an inferior group may be tough on an individual agent, but in a dynamic environment the division of labour brought about by cultural group formation may mean the population as a whole benefits.

F.6 Traits, features and cultural complexity

As has been demonstrated in the ACM (Castellano et al, 2000; Klemm et al, 2005), the two parameters for cultural complexity - number of traits, q , and number of features, F - determine the number of cultural groups emerging in a converged system. By altering the number of traits present in population - increases via innovation and decreases via replacement of memories - agents can influence the stability of particular numbers of cultural groups. A larger number of traits makes

possible more groups distinct from each other. A smaller number of traits makes likely larger, coherent groups. As noted above, more cultural complexity can mean more interdependencies, and hence harder problem solving - a phenomenon also observed in constraint satisfaction problems (Mitchell et al, 1992). So reducing the number of clusters in culture space may improve the population's performance. In addition, Bar-Yam's identification of a trade off between (informational) complexity and scale (Bar-Yam, 2004) suggests another role for preference for similarity. The trade off in cultural models between number and size of cultural groups may force social systems away from organisational forms that attempt both complex and large-scale work.

F.7 Benchmark problems

Given its similarities to other heuristic search algorithms, it is highly desirable to find some set of benchmark problems that might be put to the IRAM. Blackwell & Branke (2006) describe software to produce dynamic environments in which fitness landscapes alter in the number, location and heights of peaks. But this is intended for continuous variables only. Likewise, Clerc's set of benchmark problems for PSO are of no use to a discrete-variable method like the IRAM (Clerc, 2006, chapter 4).

Although often cited in connection with heuristic search algorithms, the Travelling Salesperson Problem (TSP) is unsuited to our tasks. It is a discrete-variable, combinatorial optimisation problem, but the operations most typically found in, say, GA - mutation and cross-over - produce strings that represent invalid routes, and therefore unacceptable solutions. By factoring in a score for infeasibility into the

fitness function, it is still possible to use GA on the TSP, but better methods may exist. Besides which, the discovery of a good scoring system for infeasibility would be an experiment in itself.

Yang & Yao (2008) offer software for dynamic environments based on bit-string solutions, again with changing numbers, locations and heights of peaks. But, as noted above, some of the most interesting aspects of the ACM and the IRAM emerge when the number of traits is much greater than 2. At $q=2$ we expect the formation of one, homogeneous cultural group. Subsections of bit-strings can, of course, be interpreted as higher-valued variables, but we do not know how such an interpretation affects the functioning of their benchmark.

Kauffman's NK fitness networks have also been suggested as benchmarks, given their "tunable" level of interdependency (K) and hence "ruggedness" (Kauffman, 1993, chapter 2), but as specified by Kauffman these only used binary variables. This is with good reason, since the size of a node's fitness table increases as S^K , where S is the number of states, normally = 2. As most of the fitness table is not used during a particular simulation run, this growth in size of the theoretical table may not be fatal to its use in practical experiments. But to date no one has explored the possibility of NK networks with non-binary variables.

We could consider matching problems, resource allocation problems, knapsack and other packing problems and scheduling problems, since these can be non-binary, discrete-variable combinatorial problems and have been addressed by plenty of methods in O.R. (Winston, 1994). But although based on real problems faced

everyday by people in organisations, it is not clear that they represent attractive demonstrations of more abstract, generic social problem solving.

F.8 Conclusions

If models like the IRAM are to tell us anything about how social agents solve life's problems, then the search for benchmarks must go on. Although the analogies with heuristic search algorithms are intriguing, describing the ideal world of *homo sociologicus* must wait for future research. What we hope this sketch has demonstrated is that agent-based models like the IRAM can bridge a gap between theoretical sociology and theories of optimisation systems, complexity and self-organisation. Several features of the agents in the theories we have drawn upon for our energy models seem suited to solving problems in complex, dynamic environments, where flexible collaboration can be an advantage. Secondly, theories of Interaction Rituals and energy – with their emphasis on social similarity and agreement rather than exchange and competition - are an acceptable theoretical basis for this research.

Bibliography

Akrich, Madeleine, Michel Callon & Bruno Latour (2002) The key to success in innovation part I: The art of intersement *International Journal of Innovation Management* 6(2) 187-206

Albert, Réka & Barabási, Albert-László (2001) Statistical Mechanics of Complex Networks *Rev. Mod. Phys.* 74 47-101

Alon, Uri (n.d.) *Uri Alon's Molecular Cell Biology Lab* Available at <http://www.weizmann.ac.il/mcb/UriAlon/> (Accessed 31st March 2009)

Anderson, John R (1993) Problem Solving and Learning *American Psychologist* 48(1) 35-44

Argote, Linda & Henrich R Greve (2007) “A Behavioural Theory of the Firm – 40 Years and Counting: Introduction and Impact” *Organization Science* 18(3) 337-349

Arifovic, Jasmina (1994) Genetic algorithm learning and the cobweb model *Journal of Economic Dynamics and Control* 18 3-28

Arthur, W Brian (1994) Inductive Reasoning and Bounded Rationality *American Economic Review (Papers and Proceedings)* 84 406-411

Arthur, W Brian (1996) Increasing Returns and the New World of Business *Harvard Business Review* July-Aug

Arthur, W Brian & Wolfgang Polak (2006) The Evolution of Technology within a Simple Computer Model *Complexity* 11(5) 23-31

Atran, Scott, Robert Axelrod & Richard Davis (2007) Sacred Barriers to Conflict Resolution *Science* 317 1039-1040

Atran, Scott & Robert Axelrod (2008 forthcoming) Reframing Sacred Values *Negotiation Journal* July

Augier, Mie & James G March (2008) "A retrospective look at *A Behavioral Theory of the Firm*" *Journal of Economic Behavior & Organization* 66(2008) 1-6

Axelrod, Robert (1996a) *Simple Version of Culture Model Source Code (Pascal)*
(Revised 4th November 1996) Available at <http://www-personal.umich.edu/~axe/research/Software/CC/CC7/CULTURE.P.html> (Accessed 31st March 2009)

Axelrod, Robert (1996b) *Cultural Model* (Revised 20th December 1996) Available at <http://www-personal.umich.edu/~axe/research/Software/CC/CC7/culture.html> (Accessed 31st March 2009)

Axelrod, R (1997a) *The Complexity of Cooperation: Agent-Based Models of Competition and Collaboration* Princeton : Princeton UP

Axelrod, Robert (1997b) The Dissemination of Culture: A model with local convergence and global polarisation *Journal of Conflict Resolution* 41 203-26

Axelrod, Robert (2006) Advancing the Art of Simulation in the Social Sciences in Rennard, Jean-Philippe ed. *Handbook of Research on Nature Inspired Computing for Economy and Management* Hersey, PA: Idea Group

Axtell, Robert (2006) *Firm Sizes: Facts, Formulae, Fables and Fantasies* Center on Social and Economic Dynamics Working Paper No. 44 Brookings Institution, John Hopkins University

Axtell, Robert, Robert Axelrod, Joshua Epstein & Michael D Cohen (1996) Aligning simulation models: a case study and results *Computational and Mathematical Organization Theory* 1 123-41

Bagni, R., R. Berchi and P. Cariello (2002) A comparison of simulation models applied to epidemics *Journal of Artificial Societies and Social Simulation* vol. 5, no. 3
<<http://jasss.soc.surrey.ac.uk/5/3/5.html>>

Baker, Wayne E (2001) Building Social Capital as an HR Competence *IHRIM Journal* April-June 98-109

Baker, Wayne (2004) Five Questions About... How to Energise Colleagues *Harvard Management Update*, July 2004, Volume 9, Number 7 Harvard Business School Publishing Corp. Available at <http://discussionleader.hbsp.com/hmu/2008/02/how-to-energize-colleagues-1.php> (Accessed 28th July 2008)

Baker, Wayne, Rob Cross, and Melissa Wooten (2003) Positive Organisational Network Analysis and Energising Relationships Chapter 21 pp328-342 in Cameron, Kim S, Jane E Dutton, and Robert E Quinn, editors, *Positive Organisational Scholarship: Foundations of a New Discipline* San Francisco : Berrett-Koehler Publishers, Inc.

Baker, Wayne & Jane E Dutton (2007) Enabling Positive Social Capital in Organisations Chapter 18 pp325-345 in Dutton, Jane E & Belle Rose Ragins *Exploring Positive Relationships at Work: Building a Theoretical and Research Foundation* London: Lawrence Erlbaum Associates, Publishers

Baker, Wayne E & Ryan W Quinn (2007) *Energy Networks and Information Use* Working paper submitted to Administrative Science Quarterly. Available at <http://www.bus.umich.edu/Academics/Departments/MO/BakerQuinnSept2007.pdf> (Accessed 13th November 2007)

Ball, Philip (2002) The physical modelling of society: A historical perspective *Physica A* 314 1-14

Ball, Philip (2006) Culture Crash *Nature* 441 686-688

Barabási, Albert-László (2002) *Linked: The New Science of Networks* Perseus Pub.:
Cambridge, Mass.

Barabási, A.-L. and Albert, R. (1999) Emergence of scaling in random networks
Science 286 509–512

Bar-Yam, Yaneer (2004) Multiscale Variety in Complex Systems *Complexity* 9(4) 37-
45

Bass, Frank (1969) A new product growth model for consumer durables *Management
Science* 15 215-227

Bass, Frank (1980) The relationship between diffusion rates, experience curves and
demand elasticities for consumer durables and technological innovations *Journal of
Business* 53 551-567

Bernard, HR, PD Killworth, MJ Evans, C McCarty & GA Shelley (1988) Studying
social relations cross-culturally *Ethnology* 27(2) 155–79

Bieniawski, Stefan & David Wolpert (2004a) Adaptive, Distributed Control of
Constrained Multi-Agent Systems *AAMAS* 1230-1231

Bieniawski, Stefan & David H. Wolpert (2004b) Product Distributions for Distributed
Optimization *International Conference on Complex Systems*, Boston, MA

Bieniawski, Stefan R., Ilan M. Krooy & David H. Wolpert (2004) Discrete, Continuous, and Constrained Optimization Using Collectives *10th AIAA/ISSMO Multidisciplinary Analysis and Optimization Conference* Albany, New York

Bigley Dunham, Jill (2005) An Agent-Based Spatially Explicit Epidemiological Model in MASON *Journal of Artificial Societies and Social Simulation* vol. 9, no. 1
<<http://jasss.soc.surrey.ac.uk/9/1/3.html>>

Bishop, J M (1989) Stochastic searching networks *1st IEE Conference in Artificial Neural Networks* London, United Kingdom

Blackwell, Tim and Jürgen Branke (2006) Multiswarms, Exclusion, and Anti-Convergence in Dynamic Environments *IEEE Transactions on Evolutionary Computation* 10(4) 459-472

Borgatti, Stephen P & Candace Jones (1998) Network Measures of Social Capital *CONNECTIONS* 21(2)

Bowers, Al & David Lednicer (1999) *Fighter Pilot Aces List* (17th May 1999)
Available at www.au.af.mil/au/awc/awcgate/aces/aces.htm (Accessed 31st March 2009)

Bowles, Samuel (2008) Policies Designed for Self-Interested Citizens May Undermine “The Moral Sentiments”: Evidence from Economic Experiments
SCIENCE 320(20 June) 1605-1609

Brailsford, Sally & Berndt Schmidt (2003) Towards incorporating human behaviour in models of health care systems: An approach using discrete event simulation
European Journal of Operational Research 150 19–31

Bratman, M E (1987) *Intentions, Plans and Practical Reason* Cambridge, MA :
Harvard University Press

Breiger, Ronald L, Carley Kathleen M, & Pattison, Philippa (2003) *Dynamic Social Network Modeling and Analysis: Workshop Summary and Papers* The National Academies Press: Washington DC

Brooks, Rodney (1991) Intelligence without Representation *Artificial Intelligence* 47
139-159

Brown, John Seely & Paul Duguid (1991) Organisational Learning and Communities-of-Practice: Toward a unified view of working, learning, and innovation *Organization Science* 2(1) 40-57

Brown, John Seely & Paul Duguid (2000) *The Social Life of Information* Boston :
Harvard Business School Press

Brown, John Seely & Paul Duguid (2001) Knowledge and Organisation: A Social-Practice Perspective *Organization Science* 12(2) 198-213

Bruch, Heike & Sumantra Ghoshal (2003) Unleashing Organizational Energy *MIT Sloan Management Review* Fall 45-51

Burt, Ronald S (1992) *Structural Holes: The Social Structure of Competition* Harvard UP: Cambridge, Mass.

Burt, Ronald S (2004) Structural Holes and Good Ideas *American Journal of Sociology* 110(2) 349-99

Burt, Ronald S (2005) *Brokerage and Closure: An introduction to Social Capital* Oxford: Oxford UP

Burton, Richard M & Børge Obel eds. (1995) *Design Models for Hierarchical Organizations: Computation, Information, and Decentralization* Boston, Dordrecht, London : Kluwer Academic Publishers

Burton, Richard M & Børge Obel (2001) Organisation In Gass, Saul I & Carl M Harris, eds., *Encyclopedia of Operations Research and Management Science*, 2nd edition Dordrecht : Kluwer Academic Publishers

Burton, Richard M & Børge Obel (2004) *Strategic Organizational Diagnosis and Design* Boston, Dordrecht, London : Kluwer Academic Publishers

Bush, Robert R & Frederick Mosteller (1951) A Mathematical Model for Simple Learning *The Psychological Review* 58(5) 313-323

Byrne, D (1997) Simulation - A Way Forward? *Sociological Research Online* 2(2)

<<http://www.socresonline.org.uk/socresonline/2/2/4.html>>

Cameron, Kim S, Jane E Dutton, and Robert E Quinn, editors (2003) *Positive Organisational Scholarship: Foundations of a New Discipline* San Francisco : Berrett-Koehler Publishers, Inc.

Carley, Kathleen (1991) A Theory of Group Stability *American Sociological Review* 56 331-354

Carley, Kathleen M (1996) A comparison of artificial and human organizations *Journal of Economic Behavior & Organization* 31 175-191

Carley, Kathleen M (2003) Linking capabilities to needs Contained in Breiger, Ronald L, Carley Kathleen M, & Pattison, Philippa (2003) *Dynamic Social Network Modeling and Analysis: Workshop Summary and Papers* The National Academies Press: Washington DC

Carley, Kathleen & Allen Newell (1994) The Nature of the Social Agent *Journal of Mathematical Sociology* 19(4) 221-262

Carley, Kathleen M & Zhiang Lin (1997) A Theoretical Study of Organisational Performance under Information Distortion *Management Science* 43(7) 976-997

Carley, Kathleen M & William A Wallace (1995) Editorial *Computational & Mathematical Organization Theory* 1(1) 5-7

Carley, Kathleen M, Lee, Ju-Sung & Krackhardt, David (2002) Destabilizing Networks *CONNECTIONS* 24(3) 79-92

Carley, Kathleen M., & Natasha Kamneva (2004) *A Network Optimization Approach for Improving Organizational Design* CASOS Technical Report CMU-ISRI-04-102 Carnegie Mellon University. Available at <http://www.casos.cs.cmu.edu> (Accessed 31st March 2009)

Carley, Kathleen M., & Jeffrey Reminga (2004) *ORA: Organization Risk Analyzer* CASOS Technical Report CMU-ISRI-04-106 Carnegie Mellon University Available at <http://www.casos.cs.cmu.edu> (Accessed 31st March 2009)

Carley, Kathleen M., Jeffrey Reminga & Natasha Kamneva (2003) Destabilizing Terrorist Networks in Breiger, Ronald L, Carley Kathleen M, & Pattison, Philippa (2003) *Dynamic Social Network Modeling and Analysis: Workshop Summary and Papers* The National Academies Press: Washington DC

Carrington, Peter J, John Scott & Stanley Wasserman eds. (2005) *Models and Methods in Social Network Analysis* Cambridge : Cambridge University Press

Castellano, Claudio, Matteo Marsili & Alessandro Vespignani (2000) Nonequilibrium Phase Transition in a Model for Social Influence *Physical Review Letters* 85 16

Centola, Damon, Juan Carlos Gonzalez-Avella, Victor M Eguiluz and Maxi San Miguel (2006) Homophily, Cultural Drift and the Co-Evolution of Cultural Groups [arXiv:physics/0609213](https://arxiv.org/abs/physics/0609213) v2 (Accessed 27 Sep 2006)

Centola, Damon & Michael Macy (2007) Complex Contagions and the Weakness of Long Ties *American Journal of Sociology* 113(3) 702–34

Challet, D & Y-C Zhang (1997) Emergence of cooperation and organization in an evolutionary game *Physica A* 246 407-418

Challet, Damien, Matteo Marsili & Yi-Cheng Zhang (2004) *Minority Games: Interacting agents in financial markets* Oxford: Oxford University Press

Clark, Andy (1997) *Being There: Putting Brain, Body and World together again* Cambridge, Mass.: MIT Press

Clark, Kenneth (1969) *Civilisation: A Personal View* London : BBC

Clerc Maurice (2006) *Particle Swarm Optimisation* ISTE: London

Clerc Maurice & Kennedy, James (2002) The Particle Swarm—Explosion, Stability, and Convergence in a Multidimensional Complex Space *IEEE Transactions on Evolutionary Computation* 6(1) 58-73

Cohen, Michael D, James G March & Johan P Olsen (1972) A Garbage Can Model of Organizational Choice *Administrative Science Quarterly* 17 1-25

Coleman, James S (1990) *Foundations of social theory* Cambridge, Mass. ; London : Belknap Press of Harvard University Press

Collins, Randall (1979) *The Credential Society: An Historical Sociology of Education and Stratification* New York: Academic Press

Collins, Randall (1981) On the Micro-foundations of Macro-sociology *American Journal of Sociology* 86 984-1014

Collins, Randall (1988) *Theoretical Sociology* Orlando, FL : Harcourt Brace Jovanovich, Inc.

Collins, Randall (1990) Stratification, Emotional Energy, and the Transient Emotions Chapter 2 pp27-57 in Kemper, Theodore D., editor, *Research agendas in the sociology of emotions* Albany : State University of New York Press

Collins, Randall (1992) *Sociological Insight: An Introduction to Non-Obvious Sociology* 2nd Edition Oxford: Oxford UP

Collins, Randall (1993) Emotional Energy as the Common Denominator of Rational Action *RATIONALITY AND SOCIETY* 5(2) 203-230

Collins, Randall (1998) *The Sociology of Philosophies: a global theory of intellectual change* London : Belknap Press, Harvard UP

Collins, Randall (2004) *Interaction Ritual Chains* Princeton, Oxford : Princeton UP

Collins, Randall (2008) *Violence: a micro-sociological theory* Princeton: Princeton UP

Collins, Randall & Robert Hanneman (1998) “Modeling Interaction Ritual Theory of Solidarity” In Doreian, Patrick & Thomas J Fararo (eds.) *The Problem of Solidarity: Theories and Models* Amsterdam : Gordon and Breach

Corne, David, Marco Dorigo & Fred Glover eds. (1999) *New Ideas in Optimisation* London: McGraw-Hill

Contractor, Noshir S, Stanley Wasserman & Katherine Faust (2006) Testing Multitheoretical, MultiLevel Hypotheses about Organizational Networks: An Analytic Framework and Empirical Example *Academy of Management Review* 31(3) 681–703

Cross, Rob, Wayne Baker & Andrew Parker (2003a) What Creates Energy in Organisations? *MIT Sloan Management Review* 44(4) 51-56

Cross, Rob, Wayne Baker & Andrew Parker (2003b) *Mapping Energy for Innovation* Available at http://www.robcross.org/pdf/roundtable/energy_and_innovation.pdf

Cross, Rob & Andrew Parker (2004a) *Charged Up: Creating Energy in Organisations*
Journal of Organisational Excellence Autumn 2004

Cross, Rob & Andrew Parker (2004b) *The Hidden Power of Social Networks:
Understanding How Work Really Gets Done in Organizations* Harvard UP: Boston
Mass.

Cross, Rob, Jane Linder & Andrew Parker (2006) *Charged Up: Managing the Energy
that Drives Innovation* accenture: Institute for High Performing Business. Available at
[http://www.accenture.com/NR/rdonlyres/70632F31-E286-4BEA-9DE4-
B618532BC53A/0/ChargedUp.pdf](http://www.accenture.com/NR/rdonlyres/70632F31-E286-4BEA-9DE4-B618532BC53A/0/ChargedUp.pdf)

Cyert, Richard M & James G March (1963/1992) *A behavioral theory of the firm* 2nd
ed. Cambridge, Mass; Oxford: Blackwell

Daft, Richard L (1998) *Organization theory and design* 6th ed. Cincinnati, Ohio :
South Western College Publishing

Daft, Richard L & Karl E Weick (1984) Toward a Model of Organisations as
Interpretation Systems *Academy of Management Review* 9(2) 284-295

Dando, M R & P G Bennett (1981) A Kuhnian Crisis in Management Science?
Journal of the Operational Research Society 32 91-103

Davidson, Donald (1984) *Inquiries into Truth & Interpretation* Oxford : Oxford University Press

Davis, Jason P, Kathleen M Eisenhardt & Christopher B Bingham (2007) Developing theory through simulation methods *Academy of Management Review* 32(2) 480-499

Dawkins, Richard (1976) *The Selfish Gene* Oxford : Oxford University Press

Deci, E L (1971) Effects of externally mediated rewards on intrinsic motivation *Journal of Personality and Social Psychology* 18(1) 105–115

Deci, Edward (1992) “The History of Motivation in Psychology and its Relevance for Management” In Vroom, V H & E L Deci eds. (1992) *Management & Motivation: Selected Readings* Penguin: Harmondsworth

Deci, Edward L with Richard Flaste (1996) *Why we do what we do: Understanding Self-Motivation* London : Penguin

Deci, Edward L & Richard M Ryan (2000) The “What” and “Why” of Goal Pursuits: Human Needs and the Self-Determination of Behavior *Psychological Inquiry* 11(4) 227-268

Deci, Edward L & Richard M Ryan, editors (2002) *Handbook of Self-Determination Research* Rochester, NY : University of Rochester Press

Deffuant, Guillaume, Silvie Huet, & Frederic Amblard (2005) An Individual-Based Model of Innovation Diffusion Mixing Social Value and Individual Benefit *American Journal of Sociology* (110)4 1041–69

De Meyer, K., J.M. Bishop & S.J. Nasuto (2003) Stochastic Diffusion: Using Recruitment for Search *Symposium on Evolvability & Interaction* Queen Mary, The University of London, UK

Dennett, Daniel C (1987) *The Intentional Stance* Cambridge, Mass.: MIT Press

Dennett, Daniel C (1991) *Consciousness Explained* London: Little, Brown

Dennett, Daniel C (1998) *Brainchildren: Essays on designing minds* London: Penguin

Dennett, Daniel C (1997) *Kinds of minds: towards an understanding of consciousness* London : Phoenix

Dennett, Daniel C (2004) *Freedom Evolves* London: Penguin

D’Inverno, Mark & Luck, Michael (1996) Understanding Autonomous Interaction in Wahlster ed. *ECAI 96 12th European Conference on Artificial Intelligence* Wiley

D’Inverno, Mark & Luck, Michael (2004) *Understanding Agent Systems* Springer: Heidelberg

Dopson, Sue & Louise Fitzgerald eds. (2005) *Knowledge to Action? Evidence-Based Health Care in Context* Oxford : Oxford University Press

Dutton, Jane E & E Heaphy (2003) *The power of high quality connections* In Cameron, Kim S, Jane E Dutton, and Robert E Quinn, editors (2003) *Positive Organisational Scholarship: Foundations of a New Discipline* San Francisco : Berrett-Koehler Publishers, Inc.

Dutton, Jane E & Belle Rose Ragins (2007) *Exploring Positive Relationships at Work: Building a Theoretical and Research Foundation* London : Lawrence Erlbaum Associates, Publishers

Easterby-Smith, Mark, Mary Crossan & Davide Nicolini (2000) Organisational Learning: Debates Past, Present and Futures *Journal of Management Studies* 37(6) 783-796

Edmonds, Bruce & Michael Moehring (2005) Agent-Based Simulation Modeling in Social and Organizational Domains *Simulation* 81(3) 173-4

Epstein, Joshua M (2008) Why Model? *Journal of Artificial Societies and Social Simulation* 11(4) <<http://jasss.soc.surrey.ac.uk/11/4/12.html>>

Farmer, J D, Patelli, P, & Zovko, I I (2005) The Predictive Power of Zero Intelligence in Financial Markets *PNAS USA* 102 (11) 2254-2259

- Ferlie, Ewan, Louise Fitzgerald, Martin Wood, & Chris Hawkins (2005) The nonspread of innovations: the mediating role of professionals *Academy of Management Journal* 48(1) 117-134
- Fiol, C Marlene & Edward J O'Connor (2002) When Hot and Cold Collide in Radical Change Processes: Lessons from Community Development *Organization Science* 13(5) 532-546
- Fioretti, Guido & Alessandro Lomi (2008) An Agent-Based Representation of the Garbage Can Model of Organizational Choice *Journal of Artificial Societies and Social Simulation* 11(1, 1) <http://jasss.soc.surrey.ac.uk/11/1/1.html>
- Flache, Andreas & Michael W Macy (1996) The Weakness of Strong Ties: Collective Action Failure in a Highly Cohesive Group *Journal of Mathematical Sociology* 21 3-28
- Fuchs, Stephan (1993) A Sociological Theory of Scientific Change *Social Forces* 71(4) 933-953
- Gagné, Marylène & Edward L Deci (2005) Self-determination theory and work motivation *Journal of Organisational Behaviour* 26 331-362
- Galbraith, Jay R (1974) Organisation Design: An Information Processing View *Interfaces* 4(3) 28-36

- Gavetti, Giovanni, Daniel Levinthal & William Ocasio (2007) Neo-Carnegie: The Carnegie School's Past, Present, and Reconstructing for the Future *Organization Science* 18(3) 523-536
- Geem, Zong Woo, Joong Hoon Kim & G V Loganathan (2001) A New Heuristic Optimisation Algorithm: Harmony Search *SIMULATION* 76(2) 60-68
- Gilbert, Nigel & Klaus G Troitzsch (2005) *Simulation for the Social Scientist* Maidenhead, UK : Open University Press
- Glover, F. (1989) Tabu Search — Part I *ORSA Journal on Computing* 1(3) 190-206
- Glover, F. (1990) Tabu Search — Part I *ORSA Journal on Computing* 2(1) 4-32
- Goffman, Erving (1959) *The Presentation of Self In Everyday Life* New York: Doubleday
- Goss, David (2007) Reconsidering Schumpeterian opportunities: the contribution of interaction ritual chain theory *International Journal of Entrepreneurial Behaviour & Research* 13(1) 3-18
- Goss, David (2008) Enterprise Ritual: A Theory of Entrepreneurial Emotion and Exchange *British Journal of Management* 19 120–137

Granovetter, Mark (1973) The strength of weak ties *American Journal of Sociology* 78 1360-1380

Grey, Chris (2005) *Studying Organisations* London : SAGE Publications

Grieg, J Michael (2002) The End of Geography? Globalization, Communications, and Culture in the International System *Journal of Conflict Resolution* 46(2) 225-243

Hammond, Ross A & Robert Axelrod (2006a) Evolution of contingent altruism when cooperation is expensive *Theoretical Population Biology* 69 333–338

Hammond, Ross A & Robert Axelrod (2006b) The Evolution of Ethnocentrism *Journal of Conflict Resolution* 50(6) 1-11

Hanneman, Robert A (1995) Simulation Modeling and Theoretical Analysis in Sociology *Sociological Perspectives* 38(4) 457-462

Hanneman, Robert A, Randall Collins & Gabriele Mordt (1995) Discovering Theory Dynamics by Computer Simulation: Experiments on State Legitimacy and Imperialist Capitalism *Sociological Methodology* 25 1-46.

Hanneman, R, & S Patrick (1997) On the Uses of Computer-Assisted Simulation Modeling in the Social Sciences *Sociological Research Online* 2(2)

<<http://www.socresonline.org.uk/socresonline/2/2/5.html>>

Harrison, J Richard, Zhiang Lin, Glenn R Carroll & Kathleen M Carley (2007) Simulation Modeling in Organizational and Management Research *Academy of Management Review* 32(4) 1229-1245

Hazy, James K. & Brian F. Tivnan (2003) Simulating agent intelligence as local network dynamics and emergent organizational outcomes *Proceedings of the 2003 Winter Simulation Conference* S. Chick, P. J. Sdnchez, D. Ferrin, and D. J. Morrice, eds

Heilbroner, Robert L (1992) *The Worldly Philosophers: The Lives, Times, and Ideas of the Great Economic Thinkers* 6th ed. updated New York: Simon & Schuster, Inc.

Holland, P & Leinhardt, S, eds. (1979) *Perspectives on Social Network Research* Academic Press: New York.

Huisman, Mark & M A J van Duijn (2003) StOCNET: Software for the statistical analysis of social networks *Connections* 25(1) 7-26

INFORMS (n.d.) *Operations Research | What O.R. Is Available* at <http://www.scienceofbetter.org/what/index.htm> (Accessed 14th August 2008)

Jennings, N., K. Sycara, & M. Wooldridge (1998) A roadmap of agents research and development. *Autonomous Agents and Multi-Agent Systems* 1 7–38

Jin, Yaochu & Juergen Branke (2005) Evolutionary Optimization in Uncertain Environments – A Survey *IEEE Transactions on Evolutionary Computation* 9(3) 303-317

Johnson-Cramer, Michael E, Salvatore Parise & Robert L Cross (2007) Managing Change through Networks and Values *California Management Review* 49(3) 85-109

Jones, Randolph M, Amy E. Henninger & Eric Chown (2002) Interfacing Emotional Behavior Moderators with Intelligent Synthetic Forces *11th CGF-BR Conference* 7 May 2002

Kauffman, Stuart (1993) *The Origins of Order: Self-Organization and Selection in Evolution* New York: OUP

Kauffman, Stuart (2000) *Investigations* Oxford : Oxford University Press

Kauffman, Stuart, Jose Lobo & William G Macready (2000) Optimal search on a technology landscape *Journal of Economic Behavior & Organization* 43 141-166

Kennedy, James (1998) Thinking is social: Experiments with the adaptive culture model *Journal of Conflict Resolution* 42(1) 56-76

Killworth, PD & HR Bernard (1978) The reverse small world experiment *Social Networks* 1 159–92

Kirkham, Richard L. (1998a) Truth, correspondence theory of. In E. Craig (Ed.) *Routledge Encyclopedia of Philosophy* London: Routledge. Available at <http://www.rep.routledge.com/article/N064> (Accessed 17th March 2009)

Kirkham, Richard L. (1998b) Truth, coherence theory of. In E. Craig (Ed.), *Routledge Encyclopedia of Philosophy*. London: Routledge. Available at <http://www.rep.routledge.com/article/N063> (Accessed 17th March 2009)

Kirkpatrick, S., C. D. Gelatt & M. P. Vecchi (1983) Optimization by Simulated Annealing *Science* 220 671-680

Klemm, Konstantin, Víctor M Eguíluz, Raúl Toral & Maxi San Miguel (2003a) Global culture: A noise-induced transition in finite systems *Physical Review E* 67, 045101(R)

Klemm, Konstantin, Víctor M Eguíluz, Raúl Toral & Maxi San Miguel (2003b) Role of dimensionality in Axelrod's model for the dissemination of culture *Physica A* 327 (2003) 1 – 5

Klemm, Konstantin, Víctor M Eguíluz, Raúl Toral & Maxi San Miguel (2003c) Nonequilibrium transitions in complex networks: A model of social interaction *Physical Review E* 67, 026120

- Klemm, Konstantin, Víctor M Eguiluz, Raúl Toral & Maxi San Miguel (2005) Globalization, polarization and cultural drift *Journal of Economic Dynamics & Control* 29 321 – 334
- Kohn, Alfie (1993) *Punished by Rewards: The Trouble with Gold Stars, Incentive Plans, A's, Praise and Other Bribes* Boston, New York : Houghton Mifflin Company
- Kossinets, Gueorgi & Duncan Watts (2006) Empirical Analysis of an Evolving Social Network *Science* 311(6-Jan) 88-90
- Kuehnert, Christian, Dirk Helbing & Geoffrey B West (2006) Scaling laws in urban supply networks *Physica A* 363 96-103
- Lant, Theresa K & Zur Shapira eds. (2001) *Organisational Cognition: Computation and Interpretation* London : Lawrence Erlbaum Associates, Publishers
- Latour, Bruno (1987) *Science in Action: How to follow scientists and engineers through society* Cambridge, MA: Harvard University Press
- Law, A. M. & W. D. Kelton (2000) *Simulation modelling and analysis* 3rd edition McGraw-Hill: New York
- L'Ecuyer, Pierre (2001) Software for uniform random number generation: distinguishing the good and the bad *Proceedings of the 2001 Winter Simulation Conference* IEEE Press

Lehman, Jill Fain, John Laird & Paul Rosenbloom (2006) A gentle introduction to SOAR, An architecture for human cognition: 2006 Update Available at <http://ai.eecs.umich.edu/soar/sitemaker/docs/misc/GentleIntroduction-2006.pdf>

Lehtinen, Aki & Jaakko Kuorikoski (2007) Computing the Perfect Model: Why Do Economists Shun Simulation? *Philosophy of Science* 74(July) 304-329

Levinthal, Daniel A (1997) Adaptation on Rugged Landscapes *Management Science* 43(7) 934-950

Levinthal, Daniel A & Massimo Warglien (1999) Landscape Design: Designing for Local Action in Complex Worlds *Organization Science* 10(3) 342-357

Lewin, Roger (1993) *Complexity: life at the edge of chaos* Dent: London

Lim, May, Richard Metzler & Yaneer Bar-Yam (2007) Global Pattern Formation and Ethnic/Cultural Violence *Science* 317 1540-1544

Linder, Jane C, Rob Cross & Andrew Parker (2006) All charged up *Business Strategy Review* 17(3) 25-29

Lloyd, P J (2001) The origins of the von Thuenen-Mill-Pareto-Wicksell-Cobb-Douglas Function *History of Political Economy* 33(1) 1-19

Luck, Michael & Mark d'Inverno (1998) Motivated Behaviour for Goal Adoption In C. Zhang and D. Lukose, (eds.) *Multi-Agent Systems: Theories, Languages and Applications - Proceedings of the Fourth Australian Workshop on Distributed Artificial Intelligence*, Lecture Notes in Artificial Intelligence 1544 58-73 Springer-Verlag

Luger, George F (2005) *Artificial intelligence: structures and strategies for complex problem solving* 5th edition. Harlow: Addison-Wesley

MacKay, David J C (2003) *Information Theory, Inference, and Learning Algorithms* Cambridge, UK: Cambridge University Press

McPherson, Miller, Lynn Smith-Lovin, & James M. Cook (2001) Birds of a Feather: Homophily in Social Networks *Annual Review of Sociology* 27 415-444

Macy, Michael W. & Andreas Flache (2002) Learning dynamics in social dilemmas *PNAS* 99(supp. 3) 7229–7236

Macy, Michael W. & Robert Willer (2002) From Factors to Actors: Computational Sociology and Agent-Based Modelling *Annual Review of Sociology* 28 143-66

Macy, Michael W, James A. Kitts & Andreas Flache (1997) *The Weakness of Strong Ties II: Collective Action Failure in a Self-organizing Social Network* Working paper available at www.people.cornell.edu/pages/mwm14

Macy, Michael W., James A. Kitts, Andreas Flache & Steve Benard (2003)
“Polarization in Dynamic Networks: A Hopfield Model of Emergent Structure” in
Breiger, Ronald L, Carley Kathleen M, & Pattison, Philippa (2003) *Dynamic Social
Network Modeling and Analysis: Workshop Summary and Papers* The National
Academies Press: Washington DC

March, James G (1991) Exploration and Exploitation in Organisational Learning
Organization Science 2(1) 71-87

March, James G & Herbert A Simon (1958) *Organizations* London : John Wiley &
Sons, Inc.

Marinier, Robert P., John E. Laird & Richard L. Lewis (2008) A computational
unification of cognitive behavior and emotion *Cognitive Systems Research* (2008)
[doi:10.1016/j.cogsys.2008.03.004](https://doi.org/10.1016/j.cogsys.2008.03.004)

Mark, Noah (1998) Beyond Individual Differences: Social Differentiation from First
Principles *American Sociological Review* 63(June) 309-330

Marks, Stephen R (1977) Multiple roles and role strain: some notes on human energy,
time and commitment *American Sociological Review* 42(Dec) 921-936

Matsumoto, Makoto (n.d.) *Mersenne Twister: A random number generator (since
1997/10)* Available at <http://www.math.sci.hiroshima-u.ac.jp/~m-mat/MT/emt.html>
(Accessed 31st March 2009)

Matsumoto, M., and T. Nishimura. 1998. Mersenne twister: A 623-dimensionally equidistributed uniform pseudo-random number generator *ACM Transactions on Modeling and Computer Simulation* 8 (1) 3-30

May, R. M. and Anderson, R. M. (1988) The transmission dynamics of human immunodeficiency virus (HIV) *Philos. Trans. R. Soc. London B* 321, 565–607

May, R. M. and Lloyd, A. L. (2001) Infection dynamics on scale-free networks *Phys. Rev. E* 64(066112)

Maynard Smith, John (1982) *Evolution and the theory of games* Cambridge, UK: Cambridge University Press

McKelvey, Bill (1999) Avoiding Complexity Catastrophe in Coevolutionary Pockets: Strategies for Rugged Landscapes *Organization Science* 10(3) 294-321

Mele, Alfred R (2005) Motivation and Agency: Precipitous *Philosophical Studies* 123 243–247

Milgram, S. (1967) The small world problem *Psychology Today* 2 60–67

Milo, R, S Shen-Orr, S Itzkovitz, N Kashtan, D Chklovskii & U Alon (2002) Network Motifs: Simple Building Blocks of Complex Networks *Science* 298 824-827

Milo, R, Itzkovitz, S, Kashtan, N, Levitt, R, Shen-Orr, S, Ayzenshtat, I, Sheffer, M, & Alon, U (2004) Superfamilies of Evolved and Designed Networks *Science* 303 1538-1542

Mingers, J (1992) Recent Developments in Critical Management Science *Journal of the Operational Research Society* 43(1) 1-10

Mintzberg, Henry & Ludo van der Heyden (1999) Organigraphs: drawing how companies really work *Harvard Business Review* Sep-Oct

Mitchell, David, Bart Selman & Hector Levesque (1992) Hard and Easy Distributions of SAT Problems *Proceedings of the Tenth National Conference on Artificial Intelligence (AAAI-92)* San Jose, CA

Mitchell, Melanie (1996) *An introduction to genetic algorithms* Cambridge, Mass. : MIT Press

Monge, Peter R & Noshir S Contractor (2003) *Theories of Communication Networks* Oxford : Oxford University Press

Morecroft, John (2007) *Strategic Modelling and Business Dynamics* John Wiley & Sons, Ltd: Chichester, UK

Morecroft, John D W & John D Sterman eds. (1994) *Modelling for Learning Organizations* Productivity Press: Portland, Oregon

Newman, M E J (2003) The structure and function of complex networks [arXiv:cond-mat/0303516v1](https://arxiv.org/abs/cond-mat/0303516v1) [cond-mat.stat-mech] 25 Mar 2003

Nowak, M & R May (1992) Evolutionary games and spatial chaos *Nature* 359 826-9

Ocasio, William (2001) "How do organisations think?" Chapter 3 in Lant, Theresa K & Zur Shapira eds. *Organisational Cognition: Computation and Interpretation* London : Lawrence Erlbaum Associates, Publishers

Odorici, Vincenza & Alessandro Lomi (2001) "Classifying Competition: An empirical study of the cognitive social structure of strategic groups" Chapter 12 in Lant, Theresa K & Zur Shapira eds. *Organisational Cognition: Computation and Interpretation* London : Lawrence Erlbaum Associates, Publishers

Panait, Liviu & Sean Luke (2005) Cooperative Multi-Agent Learning: The State of the Art *Autonomous Agents and Multi-Agent Systems* 11 387-434

Pietro Panzarasa & Nicholas R. Jennings (2001) The organisation of sociality: a manifesto for a new science of multi-agent systems *Proc 10th European Workshop on Multi-Agent Systems (MAAMAW)*, Annecy, France

Panzarasa, P. and N. R. Jennings (2002) Social influence, negotiation and cognition. *Simulation Modelling Practice and Theory* 10 (5-7) 417-453

Panzarasa, Pietro, Timothy J Norman & Nicholas R Jennings (1999) Modelling sociality in the BDI framework *Proc. 1st Asia-Pacific Conf. on Intelligent Agent Technology* Hong Kong 202-206

Parisi, Domenico, Federico Cecconi & Francesco Natale (2003) Cultural Change in Spatial Environments: The Role of Cultural Assimilation and Internal Changes in Cultures *Journal of Conflict Resolution* 47(2) 163-179

Peters, F E (1967) *Greek Philosophical Terms: A Historical Lexicon* New York: New York University Press

Peterson, Christopher M & Martin E P Seligman (2003) *Positive Organisational Studies: Lessons from Positive Psychology* in Cameron, Kim S, Jane E Dutton, and Robert E Quinn, editors (2003) *Positive Organisational Scholarship: Foundations of a New Discipline* San Francisco : Berrett-Koehler Publishers, Inc.

Pidd, Michael (1996) *Tools for Thinking: Modelling in Management Science* Wiley: Chichester, UK

Pidd, Michael (2004) "Complementarity in Systems Modelling" In Pidd, Michael ed. (2004) *Systems modelling: Theory and Practice* Chichester: John Wiley & Sons, Ltd

Pujol, Josep M, Andreas Flache, Jordi Delgado and Ramon Sangüesa (2005) How Can Social Networks Ever Become Complex? Modelling the Emergence of Complex

Networks from Local Social Exchanges *Journal of Artificial Societies and Social Simulation* 8(4) <<http://jasss.soc.surrey.ac.uk/8/4/12.html>>

Putnam, Robert D (2000) *Bowling alone: the collapse and revival of American community* Simon & Schuster: New York

Pyke, Steve (n.d.) *Steve Pyke - Photographer* Available at http://www.pyke-eye.com/view/phil_I_04.html (Accessed 15th January 2009)

Quinn, Ryan W. (2000). The Theoretical Contribution of Computer Simulation. *Best Paper Proceedings, National Academy of Management Meetings, Research Methods Division.*

Quinn, Ryan W (2007) Energising Others in Work Connections Chapter 4 pp73-90 in Dutton, Jane E & Belle Rose Ragins *Exploring Positive Relationships at Work: Building a Theoretical and Research Foundation* London : Lawrence Erlbaum Associates, Publishers

Quinn, Ryan W & Jane E Dutton (2005) Coordination as Energy-in-Conversation *Academy of Management Review* 30(1) 36-57

Ramsey, F P (1990) *Philosophical Papers* Cambridge : Cambridge University Press

Rao, Anand S & Michael P Georgeff (1995) BDI Agents: From theory to practice
Proceedings of the First International Conference on Multi-Agent Systems (ICMAS-95) San Francisco, USA

Reinke, Kristen M (2005) *Sparking knowledge processes: a social network analysis of organisational energisers and social capital* Dissertation submitted for the MSc in Organisational and Social Psychology at the London School of Economics.

Downloaded from

http://www.psych.lse.ac.uk/socialpsychology/research/organisational/kode/study/2004-05_Des/Sparking_Knowledge_ProcessesReinke2005.pdf (Accessed 22-Feb-2008)

Repenning, Nelson P (2002) A Simulation-Based Approach to Understanding the Dynamics of Innovation Implementation *Organization Science* 13(2) 109-127

Rhodes, C J & E M J Keefe (2007) Social network topology: a Bayesian approach *Journal of the Operational Research Society* 58 1605-1611

Riolo, Rick L., Michael D. Cohen & Robert Axelrod (2001) Evolution of cooperation without reciprocity *Nature* 414 441-443

Robins, Garry L., Philippa E. Pattison, and Jodie Woolcock. (2005) Small and Other Worlds: Global Network Structures from Local Processes. *American Journal of Sociology* 110 894-936

Robinson, S (2001) Soft with a hard centre: discrete-event simulation in facilitation
Journal of the Operational Research Society 52, 905–915

Robinson, Stewart (2004) *Simulation: The Practice of Model Development and Use*
John Wiley & Sons, Ltd: Chichester, UK

Robinson, S (2007a) Conceptual modelling for simulation Part I: definition and
requirements *Journal of the Operational Research Society* 1-13

Robinson, S (2007b) Conceptual modelling for simulation Part II: a framework for
conceptual modelling *Journal of the Operational Research Society* 1-14

Rodan, Simon (2005) Exploration and exploitation revisited: Extending March's
model of mutual learning *Scandinavian Journal of Management* 21 407-428

Rogers, Everett M (2003) *Diffusion of Innovations* 5th edition Free Press: New York

Rosenhead, J V & J Mingers (2001) *Rational Analysis for a Problematic World*
Revisited: Problem Structuring Methods for Complexity, Uncertainty and Conflict
second ed. Chichester: John Wiley and Sons

Ryan, Richard M & Christina Frederick (1997) On Energy, Personality, and Health:
Subjective Vitality as a Dynamic Reflection of Well-Being *Journal of Personality*
65:3 529-565

Ryan, Richard M & Edward L Deci (2000) Self-Determination Theory and the Facilitation of Intrinsic Motivation, Social Development, and Well-Being *American Psychologist* 55(1) 68-78

San Miguel, Maxi, Victor M. Eguiluz, Raul Toral, and Konstantin Klemm (2005) Binary and Multivariate Stochastic Models of Consensus Formation Computing in *Science & Engineering* Nov/Dec 20-26

Sawyer, R Keith (2005) *Social Emergence: Societies as Complex Systems* Cambridge UP: Cambridge, UK

Schelling, Thomas (1978) *Micromotives and macrobehaviour* Norton: New York

Schmidt, Berndt (2000) *The Modelling of Human behaviour* Ghent : SCSEurope
Downloaded from website www.or.uni-passau.de/english/2/modbehav.php3

Schon, Donald A (1963) Champions for Radical New Innovations *Harvard Business Review* 41(2) 77-86

Scott, John (2000) *Social Network Analysis: a handbook 2nd edition* London : SAGE Publications

Scott, W Richard (1981) *Organizations: Rational, Natural, and Open Systems* Englewood Cliffs, New Jersey : Prentice-Hall Inc.

Seligman, Martin E P & Mihaly Csikszentmihalyi (2000) Positive Psychology: An Introduction *American Psychologist* 55(1) 5-14

Shibanai, Yasufumi, Satoko Yasuno & Itaru Ishiguro (2001) Effects of global information feedback on diversity: extensions to Axelrod's adaptive cultural model *Journal of Conflict Resolution* 45(1) 80-96

Sigmund, Karl & Martin A Nowak (2001) Tides of tolerance *Nature* 414 403-405

Simon, Herbert A (1976) *Administrative behavior: a study of decision-making processes in administrative organization* 3rd ed. New York : Macmillan

SIMUL8 Corporation (2009) *SIMUL8 Simulation Software* Available at www.simul8.com (Accessed 31st March 2009)

Snijders, Tom A B (2001) The statistical evaluation of social network dynamics 361-395 in eds. Sobel, M E & M P Becker *Sociological Methodology* Blackwell: London

Snijders, Tom A.B. (2002) Markov Chain Monte Carlo Estimation of Exponential Random Graph Models *Journal of Social Structure* 3(2)

Snijders, Tom A B (n.d.) *Siena Homepage* Available at <http://stat.gamma.rug.nl/siena.html> (Accessed 31st March 2009)

Snijders, Tom A.B., Steglich, Christian E.G., and Schweinberger, Michael (2007) Modeling the co-evolution of networks and behavior. Pp. 41-71 in van Montfort, Kees, Han Oud and Albert Satorra, editors, *Longitudinal models in the behavioral and related sciences* Lawrence Erlbaum

Solow, Daniel, George Vairaktarakis, Sandy Kristin Piderit, & Ming-chi Tsai (2002) Managerial Insights into the Effects of Interactions on Replacing Members of a Team *Management Science* 48(8) 1060–1073

Stauffer, Dietrich (2003) Sociophysics Simulations *COMPUTING IN SCIENCE & ENGINEERING* May/June IEEE CS & AIP

Steglich, Christian, Tom A.B. Snijders & Michael Pearson (2004) *Dynamic Networks and Behaviour: Separating Selection from Influence* Interuniversity Center for Social Science Theory and Methodology Working Paper Downloaded from <http://www.stats.ox.ac.uk/~snijders/siena/SteglichSnijdersPearson2007.pdf>

Sterman, John D (2000) *Business Dynamics: Systems Thinking and Modeling for a Complex World* Irwin McGraw-Hill: Boston, USA.

Andrew Stout, George Konidaris, and Andrew Barto (2005) Intrinsically Motivated Reinforcement Learning: A Promising Framework For Developmental Robot Learning *Proceedings of the AAAI Spring Symposium on Developmental Robotics*

Strogatz, S. H. (2001) Exploring complex networks *Nature* 410 268–276

Sutton, R. & A. Barto (1998) *Reinforcement Learning: An Introduction* Cambridge, MA: MIT Press.

Tagliaventi, Maria Rita & Elisa Mattarelli (2006) The role of networks of practice, value sharing, and operational proximity in knowledge flows between professional groups *Human Relations* 59(3) 291-319

Taylor, Frederick W (1992) *The Principles of Scientific Management* Extracts in Vroom & Deci, 1992

Taylor, Glenn, Richard Frederiksen, Russell R. Vane III, & Edward Waltz (2004) Agent-based Simulation of Geo-Political Conflict *Innovative Applications of Artificial Intelligence (IAAI)* July 2004

Thayer, Robert E (1989) *The biopsychology of mood and arousal* Oxford: OUP

Tichy, Noel M, Michael L Tushman & Charles Fombrun (1979) Social Network Analysis for Organizations *Academy of Management Review* 4(4) 507-519

Tuckman, B W (1965) Developmental sequence in small groups *Psychological Bulletin* 63 384-399

Turner, John C (1991) *Social Influence* Milton Keynes: Open University Press

Varian, Hal R (2006) *Intermediate Microeconomics: A Modern Approach* 7th edition.

W W Norton & Company: London

Vermeulen, Freek (2008) How bad practice prevails: a model of the diffusion and persistence of detrimental management practice Working paper downloaded from www.london.edu/fvermeulen

Vroom, V H & E L Deci (1992) *Management & Motivation: Selected Readings*

Harmondsworth: Penguin

Wasserman, S & K Faust (1994) *Social Network Analysis: Methods & Applications*

Cambridge : Cambridge University Press

Watson, David, Lee Anna Clark & Auke Tellegen (1988) Development and Validation of Brief Measures of Positive and Negative Affect: The PANAS Scales *Journal of Personality and Social Psychology* 54(6) 1063-1070

Watts, Duncan J (1999) Networks, Dynamics and the Small-World Phenomenon

American Journal of Sociology 105(2) 493-527

Watts, D. J. (2003) *Six Degrees: The Science of a Connected Age* Norton, New York

Watts, Duncan J (2004) The “New” Science of Networks *Annu. Rev. Sociol.* 30 243–

70

Watts, D. J. and Strogatz, S. H. (1998) Collective dynamics of 'small-world' networks
Nature 393 440–442

Watts, Duncan J, Peter Sheridan Dodds & M E J Newman (2002) Identity and Search
in Social Networks *Science* 296 1302-1305

Weick, Karl E (1989) Theory Construction as Disciplined Imagination *Academy of
Management Review* 14(4) 516-531

Wikipedia (2009) *List of World War II aces from Germany* Available at
http://en.wikipedia.org/wiki/List_of_World_War_II_aces_from_Germany (Accessed
31st March, 2009)

Winston, Wayne L (1994) *Operations Research: Applications and Algorithms*
Belmont, California: Duxbury Press

Wolpert, David (2004) Information Theory - The Bridge Connecting Bounded
Rational Game Theory and Statistical Physics *CoRR cond-mat/0402508*

Wolpert, David H & William G Macready (1997) No Free Lunch Theorems for
Optimization *IEEE Transactions on Evolutionary Computation* 1(1) 67-82

Wolpert, David, Kevin R. Wheeler & Kagan Tumer (1999) General Principles of
Learning-Based Multi-Agent Systems *Agents* 77-83

Wooldridge, Michael J (2002) *An introduction to multiagent systems* Chichester : J. Wiley

Wooldridge M. & N. R. Jennings, editors (1995) *Intelligent Agents: Theories, Architectures, and Languages* Heidelberg, Germany : Springer-Verlag

Yang, Shengxiang & Xin Yao (2008) Population-Based Incremental Learning With Associative Memory for Dynamic Environments *IEEE Transactions on Evolutionary Computation* 12(5) 542-561

Young, H. P. (2003) The diffusion of innovations in social networks, in L. E. Blume and S. N. Durlauf (eds.) *The Economy as an Evolving Complex System* vol. 3 Oxford University Press, Oxford

Young, H Peyton (2005) *The spread of innovations through social learning* CSED Working Paper No.43, Brookings Institution, Washington DC

Young, H Peyton (2006) *Innovation Diffusion in Heterogeneous Populations: Contagion, Social Influence, and Social Learning* CSED Working Paper No.45, Brookings Institution, Washington DC