

**Aspects of the biology and behaviour of
Lernaeocera branchialis (Linnaeus, 1767)
(Copepoda : Pennellidae)**

Adam Jonathan Brooker

**Thesis submitted to the University of Stirling for the degree
of Doctor of Philosophy
2007**

Acknowledgements

I would like to express my gratitude to my supervisors Andy Shinn and James Bron for their continuous support and guidance throughout my PhD. My passage through the PhD minefield was facilitated by Andy's optimism and enthusiasm, and James' good humour and critical eye, which helped me to achieve the high standard required. I would also like to thank James for the endless hours spent with me working on the confocal microscope and the statistical analysis of parasite behaviour data.

Thanks to the Natural Environment Research Council for providing me with funding throughout the project, giving me the opportunity to work in the field of parasitology.

Thanks to the staff at Longannet power station and Willie McBrien, the shrimp boat man, for providing me with enough infected fish for my experiments whenever I required them, and often at short notice.

Thanks to the staff at the Institute of Aquaculture, especially Rob Aitken for use of the marine aquarium facility, Ian Elliot for use of the teaching lab and equipment, Linton Brown for guidance and use of the SEM and Denny Conway for assistance with digital photography and putting up with me in the lab!

I would like to thank all my friends in the Parasitology group and Institute of Aquaculture, for creating a relaxed and friendly atmosphere, in which working is always a pleasure. Also thanks to Lisa Summers for always being there throughout the good and the bad times.

Many thanks to my fishing buddies, Rob McKeown, Pat Reynolds and Mark Burns, for dragging me away from the lab when I needed a break and the many hours of good company and whisky drinking spent relaxing by the water's edge.

Last, but not least, I would like to thank my parents for their unconditional love and support, both emotionally and financially.

Declaration

I declare that this thesis has been compiled by myself and is the result of my own investigations. It has not been submitted for any other degree and all sources of information have been duly acknowledged.

Adam Jonathan Brooker

Abstract

Lernaeocera branchialis (L., 1767) is a parasitic copepod that parasitises a range of gadoids by anchoring in the proximity of the branchial chamber of its host, deriving nutrition from the blood of its host and causing serious pathogenic effects. This study investigates the taxonomy of the juvenile free-swimming stages and host location behaviour in the pre-metamorphosed adult female. The large size and distinctive appearance of the metamorphosed adult female stage, coupled with the wide exploitation and commercial importance of one of its principle final gadoid hosts, the cod (*Gadus morhua* L.), means that this species has long been recognised in the scientific literature, and here the extensive literature concerning this potentially important and damaging pathogen is re-examined to provide an up to date overview, which includes both aquaculture and wild fisheries perspectives.

Due to disagreements between several descriptions of the *L. branchialis* juvenile stages, and because the majority of the descriptions are over 60 years old, the juvenile free-swimming stages are re-described, using current terminology and a combination of both light and confocal microscopy. The time of hatching and moults in these stages is also examined. Techniques for the automated creation of taxonomic drawings from confocal images using computer software are investigated and the possibilities and implications of this technique are discussed.

The method of host location in *L. branchialis* is unknown but is likely to involve a variety of mechanisms, possibly including chemo-reception, mechano-reception and the use of physical phenomena in the water column, such as haloclines and thermoclines, to search for fish hosts. In this study the role of host-associated chemical cues in host

location by adult female *L. branchialis* is investigated by analysing the parasites behavioural responses to a range of host-derived cues, in both a choice chamber and a 3D tracking arena. To analyse the data from the experiments, specialised computer software (“Paratrack”) was developed to digitise the paths of the parasites’ movements, and calculate a variety of behavioural parameters, allowing behaviour patterns to be identified and compared. The results show that *L. branchialis* responds to host-associated chemical cues in a similar way to many copepods in the presence of chemical cues. Of the different cues tested, gadoid conditioned water appears to be most attractive to the parasites, although the wide variation in behavioural responses may indicate that other mechanisms are also required for host location. The different behavioural responses of parasites to whiting (*Merlangius merlangus* L.) and cod (*Gadus morhua*) conditioned water, which are both definitive hosts, provide some evidence for sub-speciation in *L. branchialis*. The role of chemical cues in host location of *L. branchialis*, and the relative importance of chemical and physical cues in host location are discussed.

As well as demonstrating several techniques, which show potential for further development, this work has improved our knowledge of the biology and life-cycle of *L. branchialis*. Further study of this, and other areas of *L. branchialis* biology and its host-parasite interactions, should assist the development of contingency plans for the effective management and control of this widespread and potentially devastating pathogen.

List of contents

	Page
Chapter 1 – Introduction and review	1
1. Introduction	1
2. Taxonomy	1
3. Adult morphology of the female	3
4. Life-cycle	4
4.1 Nauplius I-II	4
4.2 Copepodid	8
4.3 Chalimus I-IV	10
4.4 Adult	13
4.4.1 Morphology	13
4.4.2 Mouthparts	15
4.4.3 Infection of the definitive host	18
4.4.4 Metamorphosis	21
5. Reproduction	24
5.1 Mating strategies	24
5.2 Copulation	26
5.3 Male competition	27
5.4 Fecundity	28
5.5 Female fitness	28
5.6 Egg-strings and egg-string attachment	29
5.7 The male reproductive system and spermatozoon ultrastructure	30
6. Physiology	31

6.1 Feeding and maintenance of the internal environment	31
6.2 Respiration	33
7. Distribution	34
7.1 Geographic distribution	34
7.2 Prevalence and intensity of host infection	38
7.3 Seasonality	41
8. Pathogenicity	46
9. Concluding remarks	50
10. Research objectives	51
Chapter 2 – General materials and methods	53
1. Fish collection and maintenance	53
2. Parasite collection and culture	53
3. Sea water collection	54
4. Production of chemical cues	55
5. Video preparation	55
6. Paratrack track digitisation and analysis software	56
6.1 Paratrack main window	57
6.2 3D arena setup	60
6.3 Tracking	64
6.4 Track analysis	66
7. Microscopy	74
Chapter 3 – Description of the juvenile free-swimming stages	76
1. Introduction	76
2. Methods	77
3. Results	78

3.1 Hatching experiments	78
3.2 Nauplius I	79
3.3 Nauplius II	82
3.4 Copepodid	84
3.5 Confocal microscopy	89
4. Discussion	94
4.1 Egg hatching and moult timings	94
4.2 Comparisons with other siphonostomatoids	96
4.3 Confocal microscopy	99
Chapter 4 – Parasite behaviour and host location in <i>Lernaeocera</i>	
<i>branchialis</i>: choice chamber experiments	104
1. Introduction	104
1.1 Chemical cues	105
1.2 Behaviour analysis methods	109
1.3 Experiment objectives	111
2. Materials and methods	112
2.1 Equipment design and setup	112
2.2 Experiment design	115
2.3 Data extraction and analysis	116
3. Results	116
3.1 Comparison with control	116
3.2 Principal component analysis	131
3.3 Discriminant analysis	135
3.4 Fractal analysis	135
4. Discussion	136

4.1 Behavioural responses	138
4.2 Implications for host preference	141
4.3 Implications for host location	142
4.4 Experiment limitations and future work	144
Chapter 5 – Parasite behaviour and host location in <i>Lernaeocera</i>	
<i>branchialis</i>: 3D tracking experiments	147
1. Introduction	147
2. Materials and methods	148
2.1 Equipment design and setup	148
2.2 Experiment design	149
2.3 Statistical analysis	150
3. Results	151
3.1 Analysis of replicate effects	151
3.2 Comparison with controls	151
3.3 Principal component analysis	161
3.4 Fractal dimensions	163
4. Discussion	163
4.1 Behavioural responses	164
4.2 Experimental error	166
4.3 Implications for host preference	168
4.4 Implications for host location	169
4.5 Experiment limitations and future work	171
Chapter 6 – Conclusions	174
1. Study aims	174
2. Description of the juvenile free-swimming stages	175

3. Parasite behaviour	176
4. Paratrack	178
5. <i>Lernaeocera branchialis</i> and aquaculture	180
6. Future potential and further work	183
References	187
Appendix A	218
Appendix B	219

List of Figures

Figure 1.1. (i) The main anatomical features of an adult female *Lernaeocera branchialis*, (ii) nauplius I – dorsal aspect, (iii) nauplius II – dorsal aspect, (iv) posterior extremity of nauplius I, (v) posterior extremity of nauplius II.

Figure 1.2. The life-cycle of *Lernaeocera branchialis* (stage timings for 10°C from Whitfield *et al.*, 1988).

Figure 1.3. *Lernaeocera branchialis* (i) Copepodid, (ii) chalimus I, (iii) chalimus II, (iv) chalimus III, (v) chalimus IV, (vi) adult male, (vii) adult female.

Figure 1.4. SEMs of the buccal tube of *Lernaeocera branchialis* (i) Ventral aspect, (ii) lateral aspect, (iii) latero-ventral aspect. (iv) SEM of the abdomen of pre-metamorphosed adult female *L. branchialis* showing transverse cuticular folds.

Figure 1.5. Schematic maps of the published distribution of *Lernaeocera branchialis* and the environmental boundaries that may determine the distribution. (i) Mean sea surface temperature, (ii) salinity, (iii) definitive host distribution, (iv) Theoretical and observed distribution of *L. branchialis*.

Figure 2.1. The main features of the Paratrack front window.

Figure 2.2. The Paratrack 3D setup window.

Figure 2.3. The Paratrack parasite marker window.

Figure 2.4. (a) A 2D track image generated in Paratrack. (b) A 3D track image generated in Paratrack.

Figure 2.5. The Paratrack 2D track analysis window.

Figure 2.6. The Paratrack zone boundary window with the arena divided into three zones.

Figure 2.7. Schematic diagram of the box counting method used to estimate fractal dimensions where boxes of increasing size λ are superimposed over the track and the number of occupied boxes is counted.

Figure 2.8. The log-log plot of box size versus box number and the estimated fractal dimension (slope, D) generated in Paratrack.

Figure 2.9. The Paratrack 3D track analysis window.

Figure 3.1. Taxonomic drawing of *L. branchialis* nauplius I. (a) Dorsal aspect and (b) ventral aspect.

Figure 3.2. Light microscopy image of *L. branchialis* (a) nauplius I – dorsal aspect and (b) nauplius II – dorsal aspect.

Figure 3.3. *L. branchialis* nauplius I appendages – (a) antennule, (b) antenna and (c) mandible.

Figure 3.4. *L. branchialis* nauplius II. (a) Dorsal aspect and (b) ventral aspect.

Figure 3.5. *L. branchialis* nauplius II appendages – (a) antennule, (b) antenna and (c) mandible.

Figure 3.6. *L. branchialis* nauplius II terminal tip.

Figure 3.7. *L. branchialis* copepodid. (a) Dorsal aspect, (b) ventral aspect.

Figure 3.8. Light microscopy image of *L. branchialis* copepodid.

Figure 3.9. *L. branchialis* copepodid appendages (scale bars 25 μ m). (a) Antennule, (b) maxilliped, (c) antenna, (d) 1st swimming leg, (e) portion of 1st swimming leg showing fine hairs, (f) 2nd swimming leg and (g) caudal rami.

Figure 3.10. Generation of a specimen drawing from a confocal image. (a) Nauplius I confocal image fixed in 2.5% glutaraldehyde and stained with Blankophor, (b) extracted outline, (c) outline overlaid on original image, (d) segmental boundaries added to outline, (e) image desaturated and (f) blur filter to soften edges.

Figure 3.11. Nauplius II antenna and mandible fixed in 2.5% glutaraldehyde and stained with Blankophor. (a) Original confocal image, (b) extracted taxonomic drawing.

Figure 3.12. Nauplius II mandible fixed in 2.5% glutaraldehyde and stained with Gomori's solution. (a) Original confocal image, (b) extracted taxonomic drawing.

Figure 3.13. Nauplius II posterior fixed in 2.5% glutaraldehyde and stained with Gomori's solution. (a) Original confocal image, (b) extracted taxonomic drawing.

Figure 3.14. Copepodid fixed in 2.5% glutaraldehyde and stained with Blankophor. (a) Original confocal image, (b) extracted taxonomic drawing highlighting a problem when complex images are processed.

Figure 4.1. Schematic diagram of the choice chamber constructed from 11mm thick acrylic.

Figure 4.2. (a) The choice chamber set up with inflow tubes and drainage channel. (b) The choice chamber experimental setup, showing the video camera, peristaltic pump, light diffuser and spotlights.

Figure 4.3. Comparison with baseline control of time spent by *L. branchialis* in different choice chamber zones for each chemical cue.

Figure 4.4. Comparison with baseline control of number of periods spent by *L. branchialis* in different choice chamber zones for each chemical cue.

Figure 4.5. Comparison with baseline control of average length of each period spent by *L. branchialis* in different choice chamber zones for each chemical cue.

Figure 4.6. Comparison with baseline control of velocity and distance travelled by *L. branchialis* for each chemical cue.

Figure 4.7. Comparison with baseline control of heading, turn rate and meander of *L. branchialis* for each chemical cue.

Figure 4.8. Comparison with baseline control of number of swimming and immobile bouts by *L. branchialis* for each chemical cue.

Figure 4.9. Comparison with baseline control of average duration of each bout by *L. branchialis* for each chemical cue.

Figure 4.10. Comparison with baseline control of average velocity and distance travelled in each swim bout by *L. branchialis* for each chemical cue.

Figure 4.11. Comparison with baseline control of time spent moving and immobile by *L. branchialis* for each chemical cue.

Figure 4.12. PCA for different chemical cue types. (a) Conditioned water, (b) flesh.

Figure 4.13. PCA for different chemical cue types. (a) Mucus, (b) faeces.

Figure 4.14. Fractal dimensions (D) for swimming paths of *L. branchialis* exposed to different chemical cue types.

Figure 5.1. Schematic diagram of the 3D behaviour arena.

Figure 5.2. GLM means \pm standard deviation for 3D behaviour parameter control data divided into four replicate sets. (a) Average velocity (original data), (b) Average velocity (repeated whiting conditioned water data with decon rinse), (c) distance travelled (original data) and (d) distance travelled (repeated whiting conditioned water data with decon rinse).

Figure 5.3. Comparison with control of velocities of *L. branchialis* for each chemical cue.

Figure 5.4. Comparison with control of activity of *L. branchialis* for each chemical cue.

Figure 5.5. Comparison with control of path shape of *L. branchialis* for each chemical cue.

Figure 5.6. Comparison with control of distance travelled by *L. branchialis* for each chemical cue.

Figure 5.7. Comparison with control of number of bouts in *L. branchialis* for each chemical cue.

Figure 5.8. Comparison with control of bout duration of *L. branchialis* for each chemical cue.

Figure 5.9. Comparison with control of distance travelled and velocity in swim bouts of *L. branchialis* for each chemical cue.

Figure 5.10. PCA of the 3D behaviour parameters of *L. branchialis*, using the difference between the control and cue for each replicate.

Figure 5.11. Fractal dimension means \pm standard deviation for each corresponding control and cue group.

List of Tables

Table 1.1. Intermediate hosts of *Lernaeocera branchialis*.

Table 1.2. Definitive hosts of *Lernaeocera branchialis*.

Table 1.3. Classification of *Lernaeocera branchialis* adult female metamorphosis sub-stages found on whiting.

Table 1.4. Studies regarding the prevalence and intensity of *Lernaeocera branchialis* infections in varying sizes of different fish hosts.

Table 1.5. Studies regarding seasonality in the prevalence of *Lernaeocera branchialis* on different hosts.

Table 1.6. Studies regarding seasonality in the intensity of *Lernaeocera branchialis* on different hosts.

Table 2.1. Mean deviations from actual co-ordinates of co-ordinates measured in Paratrack with perspective correction turned on and off.

Table 3.1. Moulting times for a batch of ten *L. branchialis* nauplii.

Table 4.1. *Lernaeocera branchialis* behaviour statistics for choice chamber control (clean sea water) experiments, observed over a five minute period.

Table 4.2. Significance values for all different cue types compared to the baseline control, calculated from a one-way analysis of variance (GLM ANOVA) with a Dunnett *post-hoc* test.

Table 4.3. Data transformations used for different behaviour parameters prior to PCA analysis.

Table 4.4. Discriminant analysis correct percentages for each cue type.

Chapter 1 – Introduction and review

1. Introduction

This study concerns the marine parasitic copepod *Lernaeocera branchialis* (L., 1767) and this chapter provides an overview of current knowledge concerning its biology and host-parasite interactions. The large size and distinctive appearance of the metamorphosed adult female stage, coupled with the wide exploitation and commercial importance of its final gadoid hosts, means that this species has long been recognised in the scientific literature. The fact that the Atlantic cod, *Gadus morhua* L., is one of its key host species, and has itself had a major impact on the social and economic development of many countries bordering the North Atlantic for more than ten centuries (Kurlansky, 1998) is also a factor in its widespread recognition. *Lernaeocera branchialis* is recognised as a pathogen that could have major effects on the aquaculture industry (Khan, Lee and Barker, 1990; Anon, 2005) and with gadoid (especially cod) farming expanding in several North Atlantic countries, there is considerable potential for this parasite to become a serious problem for commercial mariculture.

The literature regarding *L. branchialis* is extensive, as it spans over a century, however, many papers are outdated or have been superseded by more recent work. Therefore, the canon of work concerning this potentially important and damaging pathogen is here re-examined to provide an up to date overview, which includes both aquaculture and wild fisheries perspectives.

2. Taxonomy

Lernaeocera branchialis is a pennellid copepod, whose final stage parasitises a range of gadoids. The Pennellidae are unique amongst parasitic copepods of fishes in having a

two host life-cycle. Most members of the family are mesoparasitic as the thorax and abdomen become deeply embedded within the host's tissues, whereas the genital segment protrudes externally and bears egg sacs (Kabata, 1970). The most obvious feature of the Pennellidae compared to most other parasitic copepods (with the exception of the Sphyrriidae) is their frequent large size. Once attached to the final host, females exhibit gigantism as a result of massive expansion in the length and girth of the genital complex and in some species the production of a substantial holdfast (Kabata, 1979). Most segmental boundaries are lost during this transformation (Sproston, 1942) and there is considerable morphological plasticity in the Pennellidae due to resistance encountered as the parasite grows through the host tissues. As a consequence there are many different 'biological forms' which have resulted in the misidentification of some species and has generated much debate amongst taxonomists.

Within the genus *Lernaeocera* (Blainville, 1822) two valid species have been identified: *Lernaeocera branchialis* (L., 1767) and *Lernaeocera lusci* (Bassett Smith, 1896). Wilson (1917) described *Lernaeocera* from the American side of the Atlantic and Schuurmans Stekhoven (1936) concluded that this morphotype was distinct from *Lernaeocera branchialis* and should be given the name *Lernaeocera wilsoni*. However, careful examination of the differences between American and European forms led Kabata (1961) to conclude that the two forms are conspecific. The species *Lernaeocera minuta* (Scott, 1900) was dismissed as a separate species by Van Damme and Ollevier (1995), who concluded that it is a miniature form of *L. lusci* and that size should not be used as a morphological characteristic due to its high dependence on host size, although this requires confirmation. *Lernaeocera obtusa* (Kabata, 1957) was identified as a separate species parasitising older haddock (*Melanogrammus aeglefinus* (L.)) (Kabata, 1958), but was later found to be a larger form of *L. branchialis* (Kabata, 1979). Other

Lernaeocera species proposed by various authors have been found to be invalid, these proposals based on unusually shaped trunks or abnormally developed holdfasts (Kabata, 1961; Kabata, 1979; Tirard *et al.*, 1993; Van Damme and Ollevier, 1995).

3. Adult morphology of the female

The final and most characteristic stage of *Lernaeocera branchialis* is the metamorphosed adult female. The cephalothorax comprises a holdfast composed of one dorsal and two lateral branches/antlers (Figure 1.1i). The neck is thin and short (Kabata, 1979) and four pairs of vestigial swimming legs are located on the neck. The expanded genital complex has three points of flexure: between the anterior cylindrical region (or neck) and trunk, around the middle of the trunk and between the trunk and abdomen. *Lernaeocera branchialis* f. *obtusa* has a longer and thicker neck than the previous form and has two points of flexure in its genital complex: in the middle of the trunk and between the trunk and abdomen. *Lernaeocera branchialis* can be discriminated from *L. lusci* by the absence of antennary processes (Van Damme and Ollevier, 1995). As the adult female parasite grows it develops a dark red colouration. The attachment site of the parasite on the final host is most commonly at the base of the third gill arch (Van den Broek, 1978; Van den Broek, 1979b), where the cephalothorax penetrates the afferent branchial artery. From here, it grows along the artery and the ventral aorta until it reaches the *bulbus arteriosus* and the holdfast develops (Smith *et al.*, 2007). Once embedded in the cardiac region, it begins feeding on host blood.

The morphology and size of adult females varies, as a result of the interaction of several environmental and host-dependent factors. Most specimens are around 2cm in length but occasionally they have been found to measure up to 5cm (Kabata, 1979). Adult females living on cod and whiting have only a short distance to cover between the base

of the gill arch and the *bulbus arteriosus* where feeding occurs, and hence have a relatively short cylindrical neck. In contrast, the form *L. branchialis* f. *obtusa*, which parasitises older haddock, tends to develop a longer, thicker neck, with a less acute angle where the neck merges into the trunk (Kabata, 1958). However, this form rarely penetrates as far as the cardiac region, but derives nourishment from one of the blood vessels, which does not appear to affect the parasite's survival rate. This form can also be distinguished by the angle of its genital flexure which is less acute than in *L. branchialis* f. *branchialis*.

4. Life-cycle

Lernaeocera branchialis was first described by Claus (1868a) as having a complex two host life-cycle. The life-cycle comprises two free-swimming nauplius stages, one infective copepodid stage, four chalimus stages and the adult copepod, each separated by a moult (Figure 1.2). Further descriptions were given by Scott (1901), Wilson (1917) and Sproston (1942). The following accounts rely principally upon the latter descriptions.

4.1. Nauplius I - II

The nauplius I has an average length of around 0.37mm, although there is quite a wide range of sizes (0.35-0.41mm) (Sproston, 1942) (Figure 1.1ii). Whitfield *et al.* (1988) recorded a mean length of 0.41mm (range 0.39-0.44mm) and width of 0.33mm (range 0.33-0.36mm). Dark red chromatophores occur laterally around the middle two thirds of the body and a darker, almost black, pigmentation surrounds the eye. Three pairs of appendages are apparent in nauplius I, with a pair of balancers at the posterior extremity. The antennules arise from the sides of a flattened frontal region and there is a short anterior spine and two long setae at the tip. Between the

antennules is a small median papilla under the cuticle (Sproston, 1942). The antennae arise ventrally from shallow depressions on the anterior lateral margins. A short spine on the distal end of the basal segment gives rise to a four-jointed exopodite and a three-jointed endopodite. Each segment of the exopodite bears a long seta, four in total and the terminal segment of the endopodite bears two long setae. The mandibles are very similar to the antennae at this stage, although the basal segments are longer and more slender.

The second nauplius stage (Figure 1.1iii) was not found by Sproston (1942) and a detailed description is lacking. From the author's personal observations nauplius II appears to be similar to nauplius I except for a pair of conical processes at the posterior extremity, which appear to be developing caudal rami, and a pair of blunt, rounded spines at either side at its base (Figures 1.1iv and 1.1v). Whitfield *et al.* (1988) describes the nauplius II as a meta-nauplius, indicating that it has more than three pairs of functional appendages, which would be the case if the paired processes at the posterior extremity are indeed caudal rami. Mean length of nauplius II was 0.54mm (range 0.51-0.55mm) and width 0.33mm (range 0.24-0.27mm) and whilst the body shapes of nauplius I and nauplius II have been described as "ovoid" and "bullet-shaped", respectively, (Whitfield *et al.*, 1988) personal observations have shown that the body shapes of nauplius I and II are very similar and that differences may be due to individual variation (Figures 1.1ii and 1.1iii).

The nauplius I moults to nauplius II about 10 minutes after hatching at 10°C. This may account for nauplius II not being found by Sproston (1942), nauplius II being mis-identified as nauplius I. Nauplius I are positively phototactic, but once moulted to

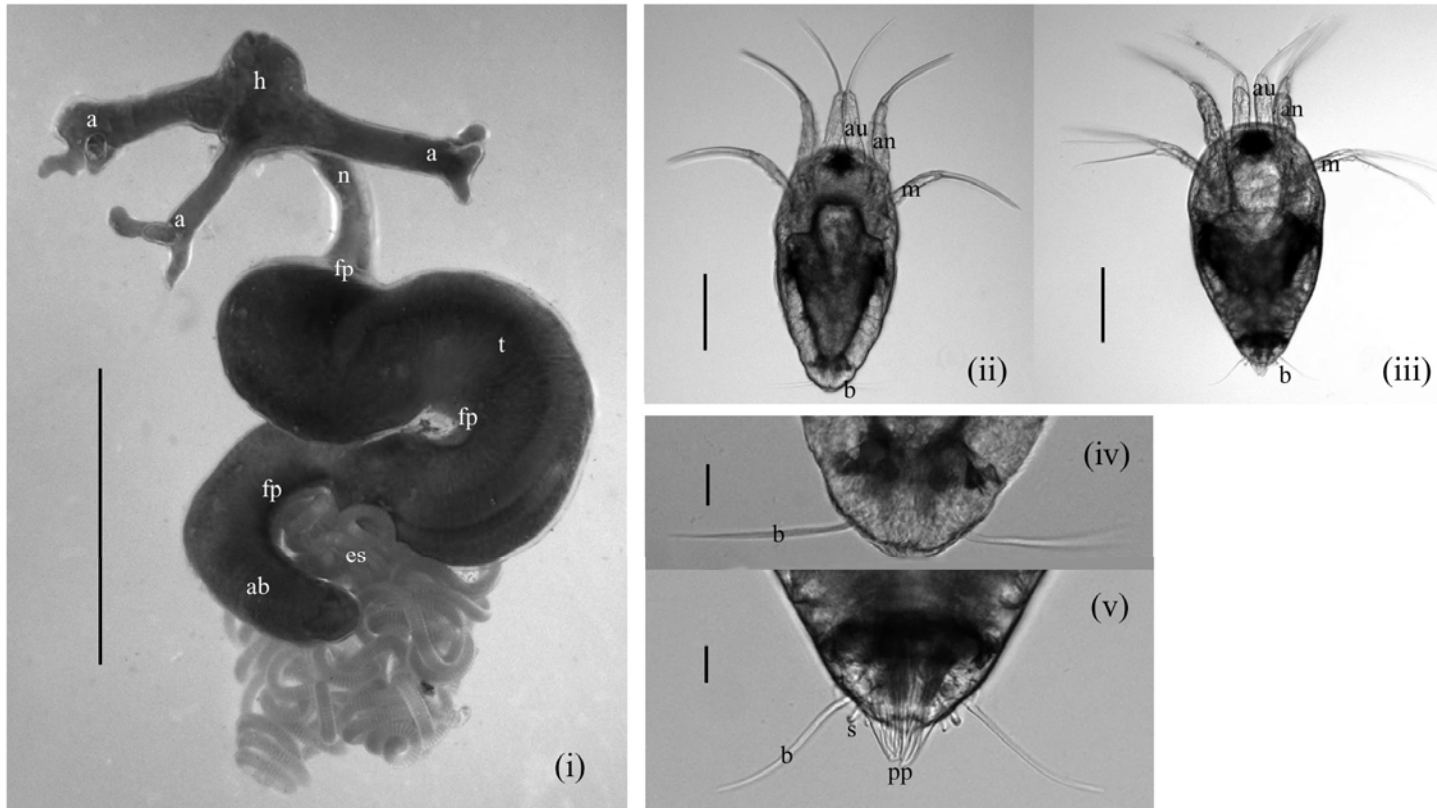

Figure 1.1. (i) The main anatomical features of an adult female *Lernaecera branchialis* (scale bar 5mm); (ii) nauplius I – dorsal aspect (scale bar 0.1mm); (iii) nauplius II – dorsal aspect (scale bar 0.1mm); posterior extremity of (iv) nauplius I (scale bar 10 μ m); and (v) nauplius II (scale bar 10 μ m). Abbreviations: h, head; a, antlers; n, neck; fp, flexion points; t, trunk; ab, abdomen; es, egg strings; au, antennule; an, antenna; m, mandible; b, balancers; s, blunt spines; pp, posterior process.

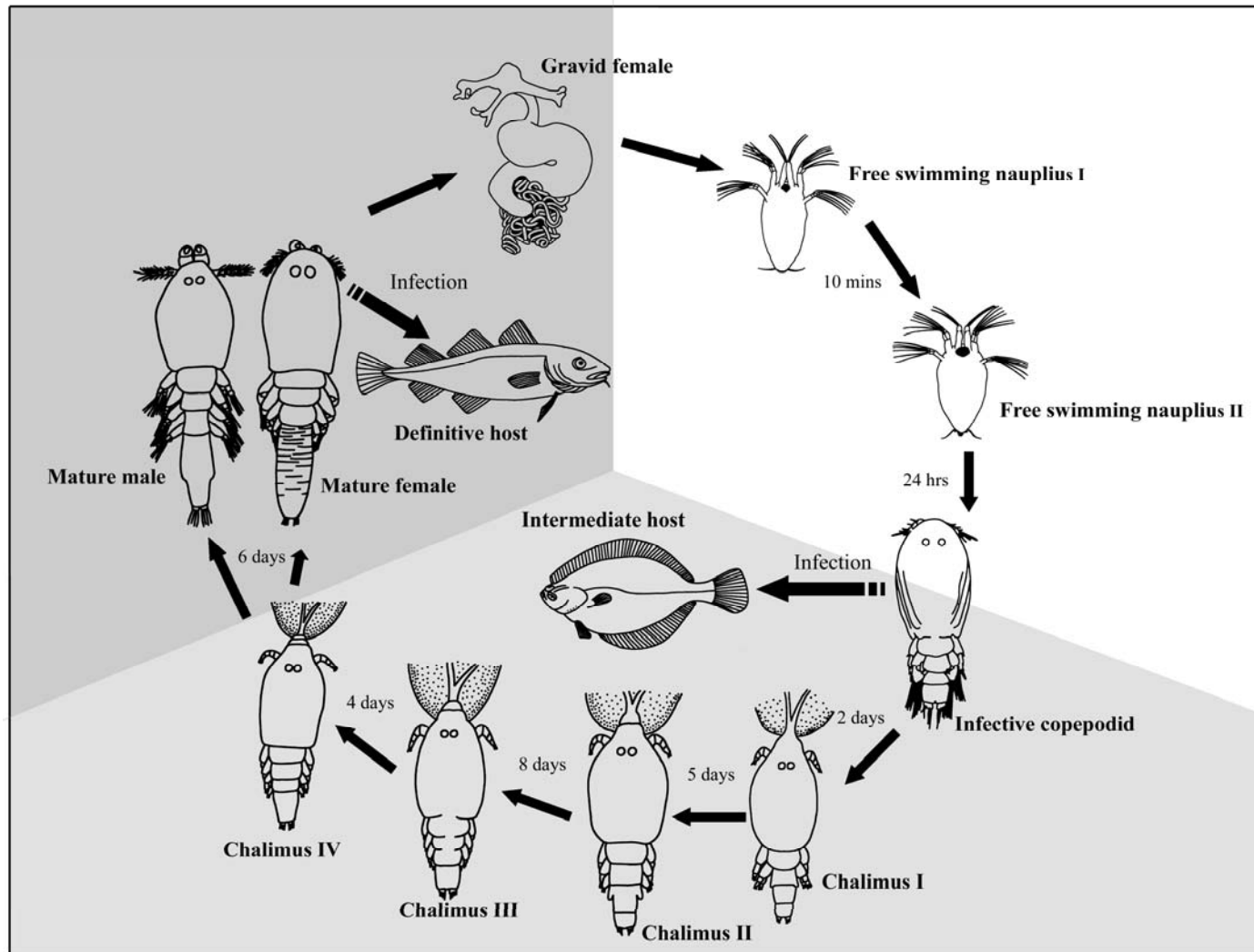

Figure 1.2. The life-cycle of *Lernaecera branchialis* (stage timings for 10°C from Whitfield *et al.*, 1988).

nauplius II they sink to the sea bed and exhibit negative phototaxis (Whitfield *et al.*, 1988).

4.2. Copepodid

The copepodid shows a large variation in size between individuals. Sproston (1942) found specimens varying from 0.39 to 0.63mm with a mean of 0.48mm (Figure 1.3i). The cephalothorax is about five-eighths of the body length and in all the post-nauplius developmental forms shows a strong ventral infolding along the lateral margins, particularly in the anterior half. The antennules consist of five segments, each equipped with setae and the distal segment bears one long, thick aesthetasc. The chelate antennae arise slightly ventral to the anterior margin of the cephalothorax and have a considerable degree of freedom – more than 180° (Sproston, 1942). Once the chelae grip a gill tip they become the anchorage of the animal until the frontal filament is produced at the next moult. The copepodid has two pairs of biramous swimming legs, the first on the second thoracic somite, which is fused to the cephalothorax, and the second on the third thoracic somite. Both rami of the first leg consist of two segments and both distal segments of the first and second legs bear five long setae, although only the exopodite bears a fine spine. Both rami of the second leg are one-segmented. The fourth thoracic somite bears two stout spines which represent the third pair of swimming legs; the fifth somite represents the pre-genital and genital segments; the sixth is the anal somite and bears two caudal rami, each with five long setae.

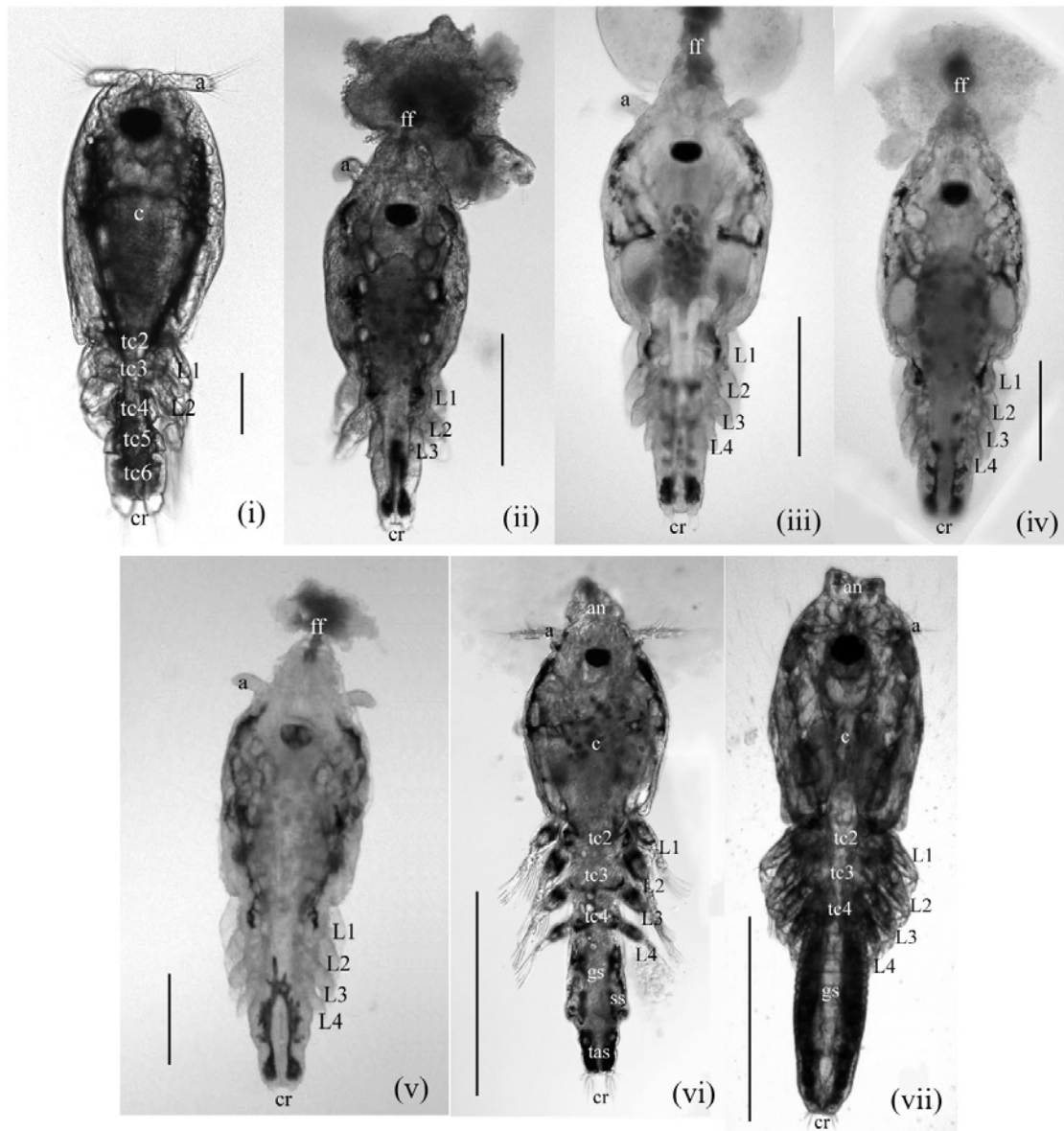

Figure 1.3. (i) Copepodid (scale bar 0.1mm); (ii) chalimus I (scale bar 0.25mm); (iii) chalimus II (scale bar 0.25mm); (iv) chalimus III (scale bar 0.25mm); (v) chalimus IV (scale bar 0.25mm); (vi) adult male (scale bar 0.5mm); (vii) adult female (scale bar 0.5mm) (all dorsal aspect). Abbreviations: a, antennule; ff, frontal filament; c, cephalothorax; L1, first swimming leg; L2, second swimming leg; L3, third swimming leg; L4, fourth swimming leg; tc2, second thoracic somite; tc3, third thoracic somite; tc4, fourth thoracic somite; tc5, fifth thoracic somite; tc6, sixth thoracic somite; gs, genital segment; tas, terminal abdominal somite; ss, spermatophore sac; cr, caudal rami.

The moult to copepodid stage from nauplius II occurs after 48 hours at 10°C (Whitfield *et al.*, 1988). The copepodid then seeks out a host and attaches to a gill tip using the chelate antennae (Sproston, 1942). They preferentially attach to the tips of the posterior gill filaments, but show no preference for the right or left gill chamber (Edwards, 1984). However, a preference is always shown for the posterior gill arches, rather than the anterior ones. This intermediate host is usually a pleuronectiform or other demersal fish. In the UK, this is usually the flounder, *Platichthys flesus* L., but in more northern latitudes the common sole, *Microstomus kitt* Walbaum, is the most common host (Kabata, 1979). Table 1.1 lists the recorded intermediate hosts. According to strict definition, the “intermediate” host is effectively the definitive host, since *L. branchialis* matures and mates on this host. However, throughout this review it will be referred to as the intermediate host, and the final host will remain the definitive host, in order to adhere to the terminology of previous workers.

4.3. Chalimus I – chalimus IV

During the moult to chalimus I, a secretion from the mid-frontal region is extruded as a thread between the antennae into the surrounding gill tissue, where it diverges into two filaments (Sproston, 1942). The rest of the secretion forms a hood dorsally and laterally, which is attached to the cephalothorax, and encloses in it the recently moulted antennae and the distal segment of the previous moult which remains attached to the gill. Soon after the moult is complete the movement of the chalimus causes the hood to crack where it joins the head and occasionally it breaks off (Sproston, 1942). Each chalimus stage can be identified by counting the number of hoods, as a new one is secreted over the old ones at each moult (Claus, 1868b). This

Table 1.1. Intermediate hosts of *Lernaeocera branchialis* (adapted from Kabata, 1979).

Host species	Family	Reference
<i>Platichthys flesus</i> (L.)	Pleuronectidae	Claus, 1868b; Pedashenko, 1898; Scott, 1901; Polyanski, 1955; Boxshall, 1974; Van Den Broek, 1979a; Edwards and Whitfield, 1983; El-Darsh, 1999; K�oie, 1999
<i>P. f. bogdanovi</i> (Sandberg)	Pleuronectidae	Shulman and Shulman-Albova, 1953
<i>Liopsetta glacialis</i> (Pallas)	Pleuronectidae	Shulman and Shulman-Albova, 1953
<i>Microstomus kitt</i> (Walbaum)	Pleuronectidae	Kabata, 1957; Kabata, 1958
<i>Limanda limanda</i> (L.)	Pleuronectidae	Shulman and Shulman-Albova, 1953
<i>Pleuronectes platessa</i> L.	Pleuronectidae	Oorde-de Lint and Schuurmans Stekhoven, 1936; Gouillart, 1937; Boxshall, 1974
<i>Solea solea</i> (L.)	Soleidae	Sproston and Hartley, 1941a
<i>Scophthalmus maximus</i> (L.)	Bothidae	Gouillart, 1937
<i>Cyclopterus lumpus</i> L.	Cyclopteridae	Metzger, 1868; Sproston and Hartley, 1941a; Fleming and Templeman, 1951; Reed and Dymond, 1951; Shulman and Shulman-Albova, 1953; Polyanski, 1955; Templeman <i>et al.</i> , 1976
<i>Agonus cataphractus</i> (L.)	Agonidae	Kabata, 1958, 1979
<i>Zoarcetes viviparous</i> (L.)	Zoarcidae	Polyanski, 1955
<i>Myoxocephalus scorpius</i> (L.)	Cottidae	Polyanski, 1955; Kabata, 1958; Boxshall, 1974
<i>Callionymus lyra</i> L.	Callionymidae	Kabata, 1958
<i>Zeugopterus punctatus</i> (Bloch)	Scophthalmidae	Kabata, 1979

frontal filament structure is different from that of other siphonostomatoid parasites that have been studied. Unlike other siphonostomatoids that have a single filament, the filament of *L. branchialis* diverges into two as it enters the gill tissue. In the genus *Lepeophtheirus* von Nordmann, 1832 a new filament can be produced at each moult (Bron *et al.*, 1991; Pike, MacKenzie and Rowand, 1993), whereas in *Caligus elongatus* von Nordmann, 1832 the filament, once lost, cannot be replaced, although the filament base is extended at each moult (Piasecki, 1996). In *L. branchialis*, a new hood is added to the filament structure at each moult, suggesting that the mechanism may be similar to that of *C. elongatus* in that the filament is separate from the chalimus body and cannot be replaced once lost.

In the chalimus I (Figure 1.3ii) the long swimming setae of the biramous legs have been lost and the rami have lost their broad flattened shape, becoming more rounded in transverse section, although the rami of the second leg now have two segments. There is a change in shape of the thoracic somites and a rudiment in place of the spines representing the third leg (Sproston, 1942). The caudal rami are smaller than in the copepodid and their setae are short and poorly developed. The moult to chalimus I occurs 2 days post-infection (p.i.) at 10°C (Whitfield *et al.*, 1988).

There is very little change in the chalimus II, although segmental boundaries are less clear (Figure 1.3iii). The antennae are swollen with segmentation shown only by folds and the leg segments are becoming more indistinct. There is an indication of the fourth thoracic somite dividing into the pre-genital and genital segments and the former shows a rudiment representing the fourth pair of legs. The labrum and labium of the mouth tube have not yet joined up and the mandibles are seen at the sides. The moult to chalimus II occurs around 7 days p.i. at 10°C (Whitfield *et al.*, 1988).

The general morphology of chalimus III stage is similar to the second although some appendages are beginning to re-differentiate (Figure 1.3iv). The free thoracic segments are less clearly marked but there is an indication of five. A fourth pair of legs has developed which have two joints at this stage, although there are no setae on the distal segment. The moult to chalimus III stage occurs around 15 days p.i. at 10°C (Whitfield *et al.*, 1988).

There is again little change in morphology after the moult to chalimus IV (Figure 1.3v). However, the segmentation of all parts is better defined than in the previous stage. Although in this stage the swimming legs are still not employed in swimming they are beginning to regain their characteristic form and the setae are slightly broader as are those of the antennules and caudal rami. The mouth tube is nearly closed at this stage and the maxillules can be seen at its sides. The maxillae of both sexes and maxillipeds of the male (the female lacks maxillipeds) are both swollen compared to those of the adult and bear no spines or claws. The moult to the chalimus IV stage occurs 19 days p.i. at 10°C and after 25 days p.i. at 10°C the parasite moults to the adult stage (Whitfield *et al.*, 1988).

4.4. Adult

4.4.1. Morphology

Once the chalimus IV has moulted to the adult there is a considerable change in shape and the body form of the copepodid has returned (Figures 1.3vi and 1.3vii), although the setae on the swimming legs are not quite so long (Sproston, 1942).

The antennules are not distinctly segmented but have a constriction separating the terminal segment, which has a rounded tip. They bear many fine setae, the terminal quarter bearing five stronger setae (Kabata, 1979) and one aesthetasc.

The antennae are very similar to those of the copepodid although they are larger and more robust. They are three-jointed with the final joint bearing a short spine.

The first two pairs of swimming legs are biramous and each ramus has two joints. The third and fourth pairs of legs are uniramous and carry three joints. In the male each ramus bears five long setae and one shorter one (Sproston, 1942). In the female, the distribution of the setae is as follows: leg 1 - 7 + spine (exopod), 6 + spine (endopod); leg 2 - 6 + spine (exopod), 6 (endopod); leg 3 - 6 + spine; leg 4 - 5 (Kabata, 1979). In the female, the coxa and the basis of the swimming legs are longer and more slender, and the setae are slightly longer than in the male (Sproston, 1942).

In the male the genital segment is barrel-shaped and contains the spermatophore sacs, which open into the tube-like gonopore near the median line (Sproston, 1942). The genital segment represents two somites and bears the vestiges of the fifth and sixth legs. Immediately below the genital segment is the free abdominal somite which is approximately square and about half the length of the genital segment (Kabata, 1979). The caudal rami each bear four setae, the inner two being longer than the finer outer two. In the male, the caudal rami are much larger and the setae longer and thicker than in the female. In the female, the thoracic segments have lost the characteristic shape seen in the male and copepodid (Sproston, 1942). They are rounded in transverse section, except the pregenital segment which is slightly quadrangular. The genital segment does not have the vestiges of the fifth legs seen in the male (Sproston, 1942) and is enormously elongated, equal to or longer than the rest of the body, with a transversely wrinkled cuticle (Kabata, 1979; Smith & Whitfield, 1988) which indicates the

region of imminent expansion (see Section 4.4.4). Once the final chalimus has moulted to the adult, the parasite is capable of swimming and displays active movement within the gill chamber of the host.

4.4.2. Mouth and mouthparts

The mouth of *L. branchialis* consists of a buccal tube situated at the end of a buccal cone, which itself comprises three rings (Figure 1.4i) (Kabata, 1962). The rings are bands of thick cuticle alternated with thinner bands, an arrangement which permits them to move in relation to one another and allows the buccal tube to shorten when pressed against the host, bringing the feeding appendages into contact with the host tissues (Boxshall, 1990b). The outer ring, the broadest and thinnest of the three, is divided by a thick plaque at the mid-anterior line (Figure 1.4i). The outer part of this bilaterally symmetrical plaque is divided into two longitudinal parts, each attached to the thickened outer rim of the ring. The plaque is suggested to act as a spring imparting a degree of elasticity to the outer ring, and thereby maintaining pressure on the host tissue as it feeds (Kabata, 1962). The middle ring is thicker and narrower than the outer ring and the inner ring is the thickest and narrowest of the three.

At the tip of the outer ring is a flared marginal membrane (Figure 1.4i), which encircles the opening of the mouth cone and may prevent the escape of macerated particles of tissue (Capart, 1948; Kabata, 1962; Boxshall, 1990b). A thin chitinous band is found around the line of attachment and is thickened at intervals by ‘studs’ of chitin (Kabata, 1962). In males, the chitinous band is broader than in the female and the studs are about twice the size but fewer in number. While the labrum forms the anterior wall of the buccal tube it does not reach the opening

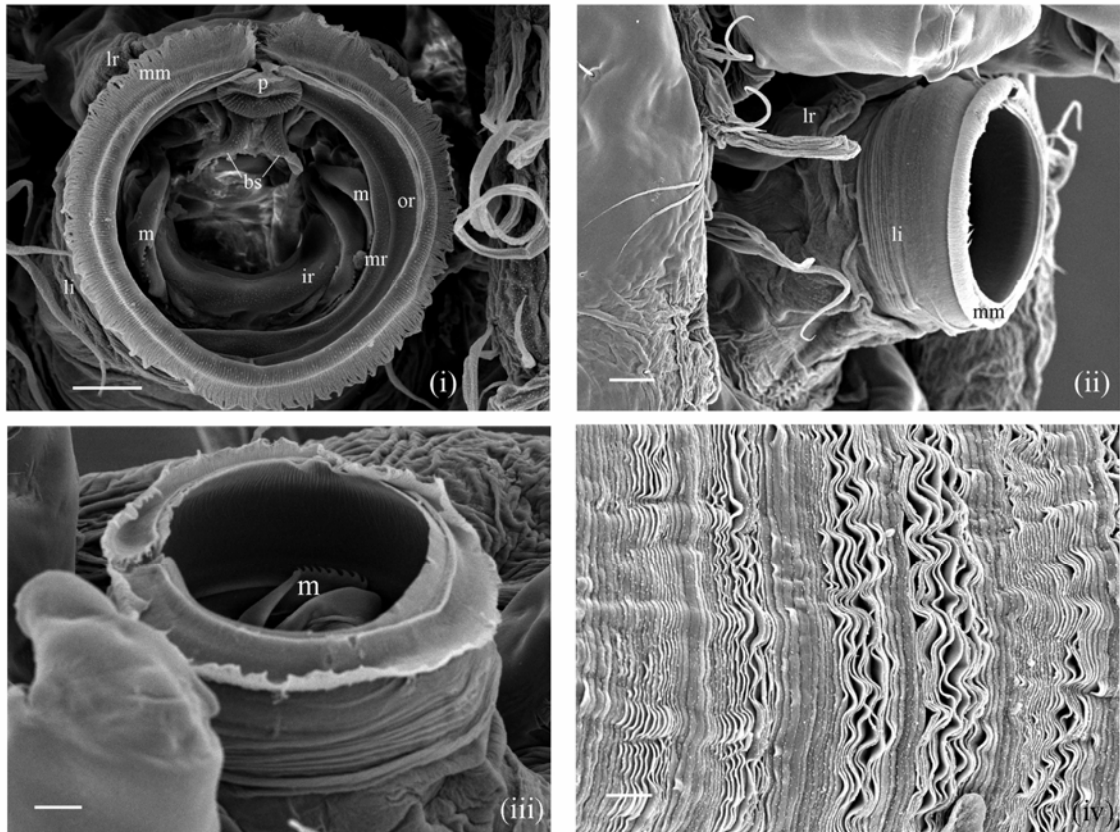

Figure 1.4. SEMs of the buccal tube of *Lernaocera branchialis*. (i) Ventral aspect; (ii) lateral aspect; (iii) latero-ventral aspect; (iv) SEM of the abdomen of pre-metamorphosed adult female *L. branchialis* showing transverse cuticular folds. Scale bars 10µm. Abbreviations: mm, marginal membrane; m, mandible; or, outer ring; p, mid-anterior plaque of the outer ring; mr, middle ring; ir, inner ring; bs, buccal stylets; li, labium; lr, labrum.

and only the labium is connected to the marginal membrane (Boxshall, 1990b) (Figure 1.4ii).

The mandible is a long, slender structure derived from the coxa (Boxshall, 1991), with a stylet-like gnathobase and its base dorso-medial to, and in close proximity to the maxillae. It is broadest at the base and narrows towards the distal end, but broadens again at the tip, where its ventral margin bears eight pointed and slightly

curving teeth (Figure 1.4iii). The mandible curves into the buccal cone and the retraction of the cone allows the serrated edges of the mandible to come into contact with the host tissue, macerating it and allowing the parasite to feed (Kabata, 1962).

At the mid-anterior line of the inner ring is attached the paired base of the buccal stylets. These bilobed structures project obliquely down towards the buccal opening (Figure 1.4i). The inner face of the base has a pair of laterally diverging processes, which are likely to be the insertion point of muscles involved with movement of the appendages (Kabata, 1962). When the buccal tube is retracted the plaque on the outer ring can close against the buccal stylets which fit into grooves in the plaque and help maintain the position of the buccal tube.

The maxillule lies laterally outside the buccal tube (Boxshall, 1990b). It is a bilobed structure consisting of an inner and outer lobe, representing the praecoxal gnathobase and palp respectively (Huys and Boxshall, 1991). The inner lobe bears two long setae at the terminal tip, whereas the outer lobe bears a single seta (Kabata, 1979).

The maxilla is posterior to the buccal tube and consists of two segments. The proximal segment, representing the precoxa and coxa (Huys and Boxshall, 1991), is broad and robust and in the female bears two large unciform processes (Kabata, 1979). The distal segment is armed with rows of setules and its tip bears a short claw with parallel rows of setules.

4.4.3. Infection of the definitive host

Mating occurs on the intermediate host (see Section 5.2) and the fertilised female then leaves to search for the definitive host. This is usually a gadoid fish, with cod, whiting (*Merlangius merlangus* L.), pollack (*Pollachius pollachius* L.) and haddock being the most common hosts (Kabata, 1979) (Table 1.2). The occurrence of metamorphosed *L. branchialis* on plaice (*Pleuronectes platessa* L.), sole (*Solea solea* (L.)), and dab (*Limanda limanda* (L.)) may indicate that they can be opportunistic parasites, as these species are usually found to be intermediate hosts. It is possible that in the absence of any definitive host options, the fertilised adult female may infect and metamorphose on an intermediate host. The mechanism of host location and identification is unknown in *Lernaeocera*, although it is likely that chemosensory detection of host derived cues is involved. In caligids, where chemotaxis has been clearly demonstrated, it is uncertain at present whether the major role of host chemo-reception is to bring the parasite into contact with an appropriate host or to assist host recognition once contact has been achieved. This mechanism was originally demonstrated in caligids by Fraile, Escoufier and Raibaut (1993), where mucus from sea bass (*Dicentrarchus labrax* L.) was shown to alter the behaviour of *Caligus minimus* (Otto, 1821). It has been demonstrated more recently in the caligid *Lepeophtheirus salmonis* (Krøyer, 1837) where a specific chemical from Atlantic salmon (*Salmo salar* L.) elicits a chemotaxic response (Devine *et al.*, 2000; Ingvarsdottir *et al.*, 2002a,b). It is likely that *L. branchialis* employs a number of mechanisms to bring it into contact with the host. *L. salmonis*, for instance, employs mechano-reception to detect host movement (Bron *et al.*, 1993; Heuch and Karlsen, 1997), chemo-reception to

Table 1.2. Definitive hosts of *Lernaecera branchialis* (Adapted from Kabata, 1979).

Host species	Family	Reference
<i>Gadus morhua</i> L.	Gadidae	Wilson, 1917; Schuurmans Stekhoven, 1936; Shulman and Shulman-Albova, 1953; Polyanski, 1955; Kabata, 1957; Kabata, 1958; Sherman and Wise. 1961; Templeman and Fleming, 1963; Boxshall, 1974; Templeman <i>et al.</i> , 1976; Linderby and Thulin, 1983; Sanchez-Lizaso and Vázquez, 1987; Vazquez <i>et al.</i> , 1988; Van Damme, 1992; Hemmingsen <i>et al.</i> , 1995, 2000; Sundnes <i>et al.</i> , 1997; Jones and Taggart, 1998; Lee and Khan, 2000
<i>Merlangius merlangus</i> (L.)	Gadidae	Schuurmans Stekhoven, 1936; Sproston and Hartley, 1941a; Desbrosses, 1945; Kabata, 1957; Smith, 1969; Shotter, 1973a, 1973b, 1976; Boxshall, 1974; Van Den Broek, 1979a; Potter <i>et al.</i> , 1988; Pilcher <i>et al.</i> , 1989
<i>Pollachius pollachius</i> (L.)	Gadidae	Gouillart, 1937; Sproston and Hartley, 1941a
<i>Pollachius virens</i> (L.)	Gadidae	Boxshall, 1974
<i>Gadus ogac</i> Richardson	Gadidae	Wilson, 1917
<i>Trisopterus minutus</i> (L.)	Gadidae	Olsson, 1869
<i>Boreogadus saida</i> (Lepechin)	Gadidae	Shulman and Shulman-Albova, 1953
<i>Eleginus navaga</i> (Koelreuter)	Gadidae	Shulman and Shulman-Albova, 1953
<i>Melanogrammus aeglefinus</i> (L.)	Gadidae	Polyanski, 1955; Kabata, 1957; Kabata, 1958

Table 1.2. Continued.

Host species	Family	Reference
<i>Phycis blennoides</i> (Brünnich)	Gadidae	Fox, 1945
<i>Molva molva</i> (L.)	Gadidae	Polyanski, 1955; Kabata, 1965
<i>Merluccius merluccius</i> (L.)	Merluccidae	Osorio, 1892; Oorde-de Lint and Schuurmans Stekhoven, 1936; Machado Cruz, 1959
<i>Ammodytes tobianus</i> L.	Ammodytidae	Schuurmans Stekhoven, 1936
<i>Dicentrarchus labrax</i> (L.)	Serranidae	Oorde-de Lint and Schuurmans Stekhoven, 1936
<i>Serranus cabrilla</i> (L.)	Serranidae	Radulescu, Nalbant and Angelescu, 1972
<i>Pholis gunnellus</i> (L.)	Blennidae	Oorde-de Lint and Schuurmans Stekhoven, 1936
<i>Labrus mixtus</i> L.	Labridae	Olsson, 1869
<i>Callionymus lyra</i> L.	Callionymidae	Hansen, 1923; Schuurmans Stekhoven, 1936
<i>Conger conger</i> (L.)	Congridae	Oorde-de Lint and Schuurmans Stekhoven, 1936
<i>Pleuronectes platessa</i> L.	Pleuronectidae	Markevich, 1956
<i>Solea solea</i> (L.)	Soleidae	Schuurmans Stekhoven, 1936
<i>Limanda limanda</i> (L.)	Pleuronectidae	Begg and Bruno, 1999

recognise host associated chemical cues (Devine *et al.*, 2000; Ingvarsdottir *et al.*, 2002) and, in adult stages, a pronounced shadow response to passing fish (Bron, *Pers. comm.*). The cues employed by *L. branchialis*, however, have yet to be established.

4.4.4. Metamorphosis

Following fertilisation, the female undergoes a dramatic transformation in size and shape and the segmental boundaries between the somites become obscured. This process begins on the intermediate host and is completed once attached to the definitive host. The metamorphosis has been divided into seven sub-stages by Sproston and Hartley (1941a) (Table 1.3). Examples of the sub-stages can be found in Khan (1988). Once a host has been located the female preferentially attaches to the filaments of the 3rd gill arch (Van den Broek, 1978; Van den Broek, 1979b) and from there migrates to the ventral portion of the gill arch (P-stage) (Kabata, 1958). The long genital complex twists and dilates, the cuticle becomes thicker and the neck extends along the branchial artery (U-V stage). Antlers grow from the cephalothorax, penetrating the host and anchoring the adult (W-stage). Metamorphosis is rapid and antlers have been found in the *bulbus arteriosus* five days after infection (Smith *et al.*, 2007).

The mouth is situated at the end of the buccal cone, at the centre of the antlers and is embedded in the blood vessel of the host (Sproston and Hartley, 1941a). Following the commencement of feeding the swollen genital segment becomes darker red and two long, irregularly coiled uniseriate egg-strings are extruded just above the abdomen (X-stage). The eggs have an extended hatching period with eggs hatching for around 12 days (Y-stage) (Whitfield *et al.*, 1988). Because of the persistence of parasite attachment structures and host tissue responses following the death of the parasite, signs of previous parasite infection have usually been characterised as stages. Due to the permanent mode of attachment the antlers remain in the host tissues after the death of the parasite and have been

Table 1.3. Classification of *Lernaecera branchialis* adult female metamorphosis sub-stages found on whiting (based on Sproston and Hartley (1941a) and Van Damme and Hamerlynck (1992)).

Sub-stage	Definition
Pennella (P1)	Abdomen elongate but straight, genital region not swollen, recently attached to the host, fully pigmented.
Pennella (P2)	One point of flexure, genital region not swollen, penetration of host tissue, rudiments of three holdfast processes present.
Immature (U)	Two or three points of flexure, genital region not swollen, holdfast processes begin to elongate.
Immature (V)	Torsion of abdomen complete – full sigmoid curvature, genital region partly swollen, holdfast processes with some secondary branching.
Mature – pre-gravid (W)	Fully metamorphosed, genital region fully swollen, fully developed branched holdfast, no external egg-strings.
Mature – gravid (X)	External egg-strings present.
X1	Immature eggs
X2	Mature pigmented eggs
Mature – post-gravid (Y)	External egg strings partly or completely spent.
Dead parasite (Z)	Remains of holdfast embedded in host tissue.
Rejected parasite (R)	Absence of parasite specimen, proliferation of gill arch tissue.

termed a Z-stage (Khan, 1988). Similarly, if the parasite is successfully rejected by the host a proliferation of gill arch tissue is found without the presence of the parasite and has been termed an R-stage. Although included by Sproston and Hartley (1941a) and Van Damme and Hamerlynck (1992), the dead parasite (Z-stage) and rejected parasite (R-stage) cannot strictly be described as parasite sub-stages. Estimates of the life span of the adult female vary from 8 weeks (Sproston, 1942), through 9-10 months (Khan, 1988), to 1 year or more (Schuurmans Stekhoven and Punt, 1937; Capart, 1948). No methods allow a direct estimation of the life span of the adult female in wild populations (Sundnes, 1970) and aquarium studies do not reflect the situation in the wild. Consequently the life span of the adult female is an issue which remains unresolved.

The metamorphosis of *L. branchialis* from a free-swimming copepod to a worm-like protrusion from the gill cavity of its host without any further moults was first reported by Metzger (1868). The mechanism that allows the cuticle to increase in size with at least a 20-fold increase in the length and girth of the abdomen, was formally elucidated using SEM and TEM ultrastructural analysis by Smith and Whitfield (1988), although Kabata (1979) described a pattern of ‘transverse wrinkling’ on the abdomen which is in fact a series of posteriorly directed transverse cuticular folds that allow expansion of the cuticle (Figure 1.4iv). The mean density of the folds on unfertilised adult females is around 1.04 per μm of abdominal length, but once the female has been fertilised the folds are pulled apart resulting in a linear decrease in the density of the folds with increasing abdominal length (Smith and Whitfield, 1988).

The development of the folded cuticle occurs before the chalimus IV to adult moult, beneath the cuticle of the chalimus IV. Using TEM, it has been shown that the cuticle consists of an outer epicuticle of about 0.08 μ m thickness and an inner procuticle, which can be divided into two layers, an inner and an outer layer (Smith and Whitfield, 1988). Once secretion of the adult cuticle has begun it is thrown into a series of first order folds around 4-6 μ m deep and then later into large scale second order folds about 8-10 μ m deep, resulting in a complex super-folded cuticle. The adult females do not possess these second order folds suggesting that they straighten out during the moult from the chalimus IV, which would account for the 43% increase in abdominal length at the moult.

The pulling apart of the first order folds results in a 6-fold increase in abdominal length (Smith and Whitfield, 1988). As the final elongation factor is about 20-fold there must be other mechanisms involved. It is suggested that these may include continued and large scale secretion after the final moult and a change in the properties of the inextensible cuticle to allow for further increases in girth and length.

5. Reproduction

5.1. Mating strategies

In common with other parasitic copepods e.g. caligids, males reach maturity before females from the same brood and once they are mature they begin to search for a mate (Anstensrud, 1989). Mate guarding by males is common in *L. branchialis* and they will establish precopula with all stages of developing females on the host, although they prefer females closer to maturation (Anstensrud, 1992; Heuch and Schram, 1996). This behaviour is common in other parasitic copepods such as *L.*

salmonis (Hull *et al.*, 1998) and *C. elongatus*, which have been seen to move vigorously over the surface of a fish in search of females and to exhibit mate guarding if females are not mature (Piasecki and MacKinnon, 1995). However, males tend to show a preference for a chalimus female over an adult virgin female in precopula with another male, suggesting that a male has little chance of taking over a female from another male (Anstensrud, 1992).

Sex-specific signals are developed early in *L. branchialis* as significantly more mature males will choose chalimus I females than chalimus I males. However, mature males sometimes assume precopula with immature males, indicating that sex-specific signals may be weak and confusing at this stage (Heuch and Schram, 1996). The establishment of these male-male associations suggests that mate recognition may be based on tactile stimuli and not pheromones. Mature males always leave the immature parasite in this situation once the correct signals are not obtained. Males can also recognise an already inseminated female, which has attached spermatophores, and will refuse to mate with a non-virgin female if presented with other female options.

It is likely that males will guard the first female they encounter as many males are found guarding immature females, while some mature females are found without male company (Kabata, 1958). In most cases, the first male to take up the precopula position with a chalimus female also takes up the copula position once the female matures (Anstensrud, 1989, 1992). At high male:female ratios, males tend to surround a female or form clusters of males only, attached by their chelate antennae to a gill filament close together or attached to each other (Anstensrud, 1989, 1992).

5.2. Copulation

After a chalimus female has been located, the male assumes a precopula position with its antennae gripping the female in the vicinity of its frontal attachment apparatus (Boxshall, 1990a), often penetrating the gill filament to grip the frontal filament of the female (Kabata, 1958). The male remains in this position until the female moults into the adult. Immediately after the female's ecdysis, the male crawls backwards on the dorsal side of the female using its antennae while the maxillipeds are moved back and forth over the ventral surface of the female (Anstensrud, 1989). Once the male reaches the copula position it grasps the female's trunk just behind the last leg-bearing thoracic segment with its antennae. Transfer of spermatophores takes place within one hour of the establishment of the copula position. The spermatophores are expelled after a series of contractions of the male's genital complex and are pushed anteriorly towards the ventral surface of the male's genital complex, being retained by several rows of hook-like processes just anterior to the genital orifices. The male then bends its posterior segments under the female's genital complex and positions the spermatophores on the female's genital opening. The spermatophores are held in position by the long setae of the male's first swimming legs until the male's trunk slowly straightens out. Copulation is complete within 2-3 minutes. Males take 3 days to produce the first pair of spermatophores and 17 hours to produce each of the following ones (Anstensrud, 1990b).

Anstensrud (1989) found that males without maxillipeds are not usually able to fertilise females successfully. In the Pennellidae, only males have maxillipeds (Kabata, 1979), and this suggests that they may be connected with reproduction, possibly being used for mechano-reception of the female's genital opening,

orientation on the female, determination of the maturity of the female (Anstensrud, 1989) and relaxation of the female's genital opening.

5.3. Male competition

The females can be inseminated more than once and often the first male to assume precopula with the female will inseminate her repeatedly (Anstensrud, 1990c). This may be to reduce sperm competition from subsequent males by filling up the *receptaculum seminis* of the female, as sperm masses from different males become mixed within the receptaculum seminis (Anstensrud, 1990b, 1990c). Egg production starts 7-9 months after copulation (Anstensrud, 1990c; Khan, 1988), allowing plenty of time for sperm masses to become mixed. In experiments, 97% of females were inseminated at least twice and the number of males copulating with the first female more than three times increased significantly in the presence of a male competitor (Anstensrud, 1990c). Given other options, mature males avoid inseminated females, preferring virgin females or immature stages, again indicating the likelihood of sperm competition within the *receptaculum seminis* (Heuch and Schram, 1996). Based on spermatophore volumes and quantities of sperm in the *receptaculum seminis* of females, the maximum number of inseminations per female was five (Anstensrud, 1990c).

The amount of time spent on the intermediate host is reduced as a female is inseminated more. Virgin females tend to spend around 8 days on the host, whereas females that have been copulated once or twice spend around 4 and 3 days, respectively (Anstensrud, 1990a). This suggests that one copulation is not sufficient and that lingering on the intermediate host is an adaptation to secure sufficient insemination. Due to the short period of time that females spend on the intermediate

host, the males remain and tend to accumulate as they do not leave the intermediate host, leading to high male:female ratios. The 50% survival time of adult males is ~ 5 weeks (Anstensrud, 1990c).

5.4. Fecundity

Once a pair of egg-strings has been extruded, embryonic development of *L. branchialis* takes around 13 days at 10°C (Whitfield *et al.*, 1988). The number of eggs in a single pair of egg-strings is high for parasitic copepods. Whitfield *et al.* (1988) found a mean of 1,445 and a maximum in excess of 3,000 eggs. Under laboratory conditions, hatching continued for a maximum of 12 days and followed an exponential decline. Less than half (44.2%) reached the infective copepodid stage, the rest failing to hatch or develop to the nauplius II or copepodid stages. However, if the egg-strings are removed, the female extrudes another set within 48 hours, demonstrating the iteroparous reproductive capacity of *L. branchialis*. It is likely that the female can rapidly produce several egg-strings, maybe one pair every 2 weeks, depending on water temperature (Anstensrud, 1990c). Given that oviposition may continue for a year (Khan, 1988), the maximum fecundity of a single *L. branchialis* female is estimated to be around 36,400 eggs (Heuch & Schram, 1996).

5.5. Female fitness

The high fecundity of *L. branchialis* females may be a result of the two host life-cycle (Anstensrud, 1990c). Females probably have relatively high post-copula mortality once they leave the intermediate host and as a consequence their fitness may be reduced. This is compensated for by high fecundity. The need to accommodate this high fecundity of females may be a selective mechanism resulting in a relatively high volume and rapid production of spermatophores by males

(Anstensrud, 1990b). This high spermatophore volume may also serve to benefit the female nutritionally during the pelagic phase, as the seminal constituents may be absorbed from the *receptaculum seminis* after insemination (Anstensrud, 1990b). The presence of seminal fluid in the *receptaculum seminis* is also essential for the metamorphosis of the female as Anstensrud (1990a) found that significantly fewer virgin females reached the penella stage and none metamorphosed past the U-stage on the final host.

5.6. Egg-strings and egg-string attachment

The egg-strings of *L. branchialis* are long, narrow and possess individually stacked eggs i.e. uniseriate. Each irregularly coiled egg-string is extruded from a gonopore situated just above the constriction which divides the abdomen from the genital complex. Branching tree-like structures, developed from the vitellarium, form the central axis of each egg-string and are held to them by thin membranes, giving them an interwoven appearance (Schram and Heuch, 2001). This structure is unique to the genus *Lernaecera* (Kabata, 1979).

Like many other parasitic copepods the egg-strings are mechanically secured by a hook inside the genital complex, which is found just outside the atrium on each side (Schram and Heuch, 2001). The cupulate hook bases are attached to the body wall with connective tissue and muscle, with five bands of muscle on each hook for suspension and movement, between 1mm and 1.8mm long. A suture in the atrium allows the hook tip to enter and protractor and retractor muscles allow the hook to act as a lever and swing across the atrium. Where the tip of the hook makes contact with the proximal end of the egg-string a concave depression is formed in the egg-string

as the hook enters a notch in the opposite side of the atrium, locking the egg-string in place.

5.7. The male reproductive system and spermatozoon ultrastructure

In the mature male, the reproductive system consists of two linearly arranged sets of reproductive organs, each comprising a testis, a *vas deferens*, a seminal vesicle and a spermatophore sac (Capart, 1948). The testes are located in the cephalothorax and are bilobed, each consisting of a main lobe attached to the *vas deferens* and a smaller central lobe (Grant and Whitfield, 1988). Spermiogenesis begins with the spermatocytes which are located more dorsally and proceeds ventrally in the testis and along the *vas deferens* where the spherical spermatids, each about 4 μ m diameter, are transformed into mature spermatozoa. The mature spermatozoa are packed in ovoid spermatophores in the spermatophore sacs.

The mature spermatozoa are thread-like cells about 30 μ m in length and 1 μ m in diameter (Grant and Whitfield, 1988). The cells are immotile in seawater. SEM analysis reveals that the cell is javelin-shaped, tapering at both ends and displaying a four-lobed helical twist along its surface. The spermatozoon does not have a defined nucleus enclosed by a nuclear envelope, but the nuclear chromatin is a finely granular / filamentous material associated with a pseudomembranous structure that extends along the central core of the cell. The cell membrane consists of longitudinally orientated microfilaments and some microtubules, although there are no mitochondria or acrosome present in the cell. The characteristics possessed by the spermatozoa of *L. branchialis* are not shared by any other copepod species, although each individual characteristic is possessed by at least one other species (Grant and Whitfield, 1988).

6. Physiology

6.1. Feeding and maintenance of the internal environment

The cuticle of *L. branchialis* is highly chitinised (Sproston and Hartley 1941b), meaning that the parasite is relatively impermeable. Sproston and Hartley (1941b) found that unlike most marine invertebrates, *L. branchialis* is able to keep its body hypotonic to its marine environment as long as it remains attached to the host. Feeding on the hypotonic blood of the host compensates for slow osmosis of water through the body wall. However, once removed from the host, isotonicity is established with the external medium due to water being taken in through the mouth in place of the blood of the host (Sproston and Hartley, 1941b). Since the parasite is hypotonic to its external environment, it is likely that there is no intake of water by the anus. Sproston and Hartley (1941b) observed no movement of fine particles in suspension around the anus and microscopical examination shows a funnel-like depression at the posterior extremity of the parasite but it does not perforate the cuticle. This is not surprising, as in many blood feeding parasites the digestion is slow but complete. However, free iron liberated from haemoglobin catabolism is toxic and blood feeding parasites must develop mechanisms to prevent iron reaching toxic levels. In the pennellid, *Cardiodectes medusaeus* (Wilson) free iron is converted to non-toxic ferritin and stored in the frontal attachment organ as ferritin crystals (Perkins, 1985). As *L. branchialis* is unable to excrete dietary waste products, it is possible that a similar mechanism is present and a non-toxic form of iron is stored in the parasite.

Although *L. branchialis* can maintain its haemolymph hypotonic to sea water, it is dependant on the osmolarity of the surrounding medium. In experiments, the osmolarity of the parasite haemolymph decreased asymptotically in 50% seawater

such that *L. branchialis* cannot survive below a salinity of about 16‰ (Knaus Knudsen and Sundnes, 1998). This is in line with a survey in Baltic waters that reported that *L. branchialis* was not found in waters of salinities below 18‰ (Sundnes *et al.*, 1997).

Feeding is discontinuous and the mouth is opened only at well spaced intervals to admit a meal of blood which is retained in the gut for a long period (Sproston and Hartley, 1941b). The blood pressure of the host is increased around the site of injury by the parasite due to the fibrotic thickening of the ventral aorta and bulbus arteriosus (Smith *et al.*, 2007) so the parasite controls the intake of blood by keeping the mouth closed and opening it only briefly to feed at intervals. These feeding periods are suggested to be triggered by a drop in hydrostatic pressure due to the slow osmosis of water through the cuticle in response to the hypotonicity of the parasite to sea water (Sproston and Hartley, 1941b). Once the hydrostatic pressure drops below a limiting value the mouth is opened to admit host blood and the hypotonicity is restored. This discontinuous feeding is supported by measurements of osmotic pressure of the body fluid of *L. branchialis* attached to the host, where a considerable variation in values was observed (Panikkar and Sproston, 1941).

Although *L. branchialis* generally has a red colouration, there is no open connection between the vascular system of the host and the digestive system of the parasite (Sundnes, 1970). The haemocoel has a red colouration, but this is distinct from host haemoglobin and the digestive system of the parasite has no red colouration with no haemoglobin present, which indicates that haemoglobin is separated from the blood serum before it enters the parasite (Sundnes, 1970).

Although it has not been demonstrated in *L. branchialis*, immunosuppression of the host is common in ectoparasites and it is possible that *L. branchialis* uses some form

of immunosuppression to counteract the host's immune response. Fast *et al.* (2002, 2004) found evidence that the caligid *Lepeophtheirus salmonis* immunoregulates its host at the sites of attachment and feeding. Two substances amongst other undescribed substances were found, prostaglandin E₂ and trypsin, which were shown to immunomodulate the host. In other arthropod parasites prostaglandin E₂ is known to play a variety of roles, including vasodilation, which would be useful in maintaining blood flow to the site of feeding since blood constitutes a component of the diet of *L. salmonis* (Brandal, Egidius and Romslo, 1976; Bricknell *et al.*, 2003). As *L. branchialis* is entirely a blood feeder, prostaglandin E₂ could have a role in maintaining a blood flow. Prostaglandin E₂ could also adversely affect site-specific leucocyte recruitment and activity (Papadogiannakis and Johnsen, 1987; Papadogiannakis, Johnsen and Olding, 1984; To and Schrieber, 1990), which could help prevent rejection of *L. branchialis* by its host. As trypsin is found in the guts and saliva of some arthropod parasites (Kerlin and Hughes, 1992) and also inhibits phagocytosis in monocytes (Huber *et al.*, 1968). Fast *et al.* (2003) suggested that trypsin derived from *L. salmonis* may decrease host phagocytic activity and immune responses after infection and it is possible that *L. branchialis* employs a similar mechanism to locally immunomodulate the host. Although immunosuppression of the host is most likely to occur at the site of attachment, an accumulation of several parasites may eventually cause immunosuppression of the entire host (Fast *et al.*, 2003) and may be the reason why fish harbouring secondary infections concurrent with *L. branchialis* are more likely to succumb to the infection (Khan, 1986).

6.2. Respiration

In many parasitic copepods respiration occurs principally through the cuticle and / or the anus but Sproston and Hartley (1941b) suggest that in *L. branchialis* cuticular

respiration is minimal due to heavy chitination and that oxygen enters the parasite via the mouth in the form of the blood of the host. However, Sundnes (1970) propose that this is not the case as the usual location of *L. branchialis* is on the venous side of the gills where oxygen content is low. Diffusion of oxygen through the cuticle may be sufficient for a sluggish animal with the limited size of *L. branchialis* and osmotic experiments indicated that gas diffusion is evident. A two way peristalsis causes turbulence within the haemocoel and may be the mechanism of internal oxygen distribution (Sproston and Hartley, 1941b).

7. Distribution

7.1. Geographic distribution

The geographic distribution of *L. branchialis* is circumscribed by the distribution of its intermediate and final hosts and restricted by salinity and temperature. *L. branchialis* is, therefore, restricted to the North Atlantic and adjacent seas (Kabata, 1979) (Figure 1.5). As the swimming abilities of the pre-metamorphosed adult are suggested to be limited (Sproston, 1942) and the timing of this stage is short (Schuurmans Stekhoven and Punt, 1937), infection of the definitive host is suggested to be possible only where its distribution directly overlaps that of the intermediate host.

Around the majority of the UK, the life-cycle of *L. branchialis* alternates between *Platichthys flesus* (flounder) as the intermediate host and *Merlangius merlangus* (whiting) or *Gadus morhua* (cod) as the definitive host. As the flounder is predominantly an inshore and estuarine species the habitats of these species only overlap when juvenile whiting and cod migrate inshore to nursery grounds and this is

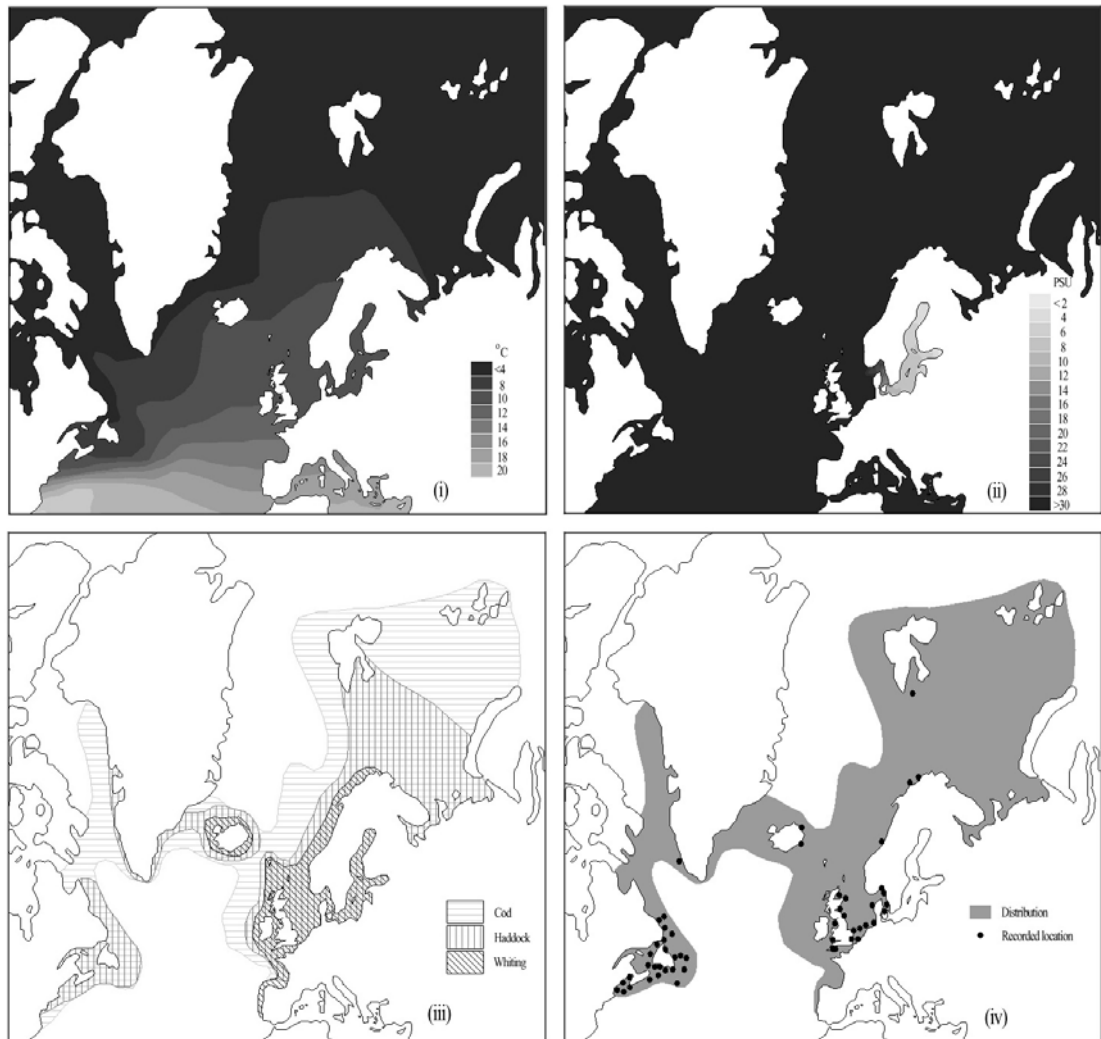

Figure 1.5. Schematic maps of the published distribution of *Lernaocera branchialis* and the environmental boundaries that may determine the distribution. (i) Mean sea surface temperature; (ii) salinity; (iii) definitive host distribution; (iv) theoretical and observed distribution of *L. branchialis*.

where the greatest infection takes place (Sproston and Hartley, 1941a; Shotter, 1973ab; Van den Broek, 1979a; Potter, Gardner and Claridge, 1988; Pilcher, Whitfield and Riley, 1989). Whiting caught in deeper, offshore waters have very little infection as they have moved out of the range of the intermediate host (Sproston and Hartley, 1941a; Shotter, 1973a,b; Potter *et al.*, 1988; Pilcher *et al.*, 1989), although fish that have previously been infected and outlived the parasite can be

identified by anchor wounds in the gill arch (Pilcher *et al.*, 1989). Around the Isle of Man, *L. branchialis* was found to be more prevalent in inshore locations than in offshore deeper water, although the parasite was more prevalent on the east coast than on the west coast (Shotter, 1973a,b). This is thought to be due to flounder being more common on the east coast than the west coast. In the northern North Sea, lemon sole (*Microstomus kitt* (Walbaum, 1792)) are the predominant intermediate host for *L. branchialis* (Kabata, 1957; Kabata, 1958). As lemon sole is not restricted to shallow inshore waters, maximum prevalence of *L. branchialis* is usually found where there is a high abundance of lemon sole and haddock or cod, the most common definitive hosts in this area.

On the Northwest Atlantic coast, *Cyclopterus lumpus* L. (lumpfish) have been found to be the most common intermediate host of *L. branchialis* (Fleming and Templeman, 1951; Templeman, Hodder and Fleming, 1976). In the waters around Newfoundland, the prevalence of *L. branchialis* often reaches 100% on lumpfish (Templeman *et al.*, 1976), although the prevalence of the parasite decreases in southern Newfoundland waters. The parasite is most abundant on cod from inshore waters, where they inhabit similar areas to the lumpfish, than in deeper offshore waters. Templeman and Fleming (1963) noted that the highest prevalence on cod occurs in the warmer, southern waters of Newfoundland, rather than cooler, northern waters. They suggest that higher growth rates in cod in warmer waters may reduce the pathogenic effects of *L. branchialis*, allowing southern Newfoundland cod populations to support a higher level of infection. Further north around Labrador, prevalence on cod decreases with increasing latitude (Jones and Taggart, 1998). This pattern correlates with the distribution of the intermediate host, lumpfish, which is found less frequently in more northern waters (Stevenson and Baird, 1988).

Conversely, on the Norwegian coast the prevalence on cod was found to decrease from north to south (Sundnes, 1970). The prevalence in cod was very low (<1%) in catches from the Spitzbergen Bank, which may be due to the distance from the coast (and the habitat of the intermediate host) (Sanchez-Lizaso and Vasquez, 1987; Vasquez, Paz Canalejo and Escalante, 1988). However, there may also be other factors affecting infected fish, which could explain the low prevalence of infection in offshore waters, such as mortality caused by the parasite, an inability to swim into deeper waters due to retention of excessive air in the swim bladder and predation of weakened infected fish during migration (Khan, 1988). Compared to studies in European waters, the prevalence on the definitive host is relatively low, around 10-20%, which may reflect the fact that the habitats of the intermediate host and definitive host often do not overlap directly.

Lernaeocera branchialis cannot survive in salinities below 16‰ (Knaus Knudsen and Sundnes, 1998) (see Section 6.1). In a study of *L. branchialis* on cod in Baltic waters, no parasites were found in salinities below 20‰ (Sundnes *et al.*, 1997). There is only one record of *L. branchialis* being found in the Mediterranean (Brian, 1906), although this may have been a misidentification. Sherman and Wise (1961) found that the prevalence of *L. branchialis* decreases with decreasing latitude on the West Atlantic coast. At 44° North, where ocean surface temperatures can range from 2-5°C in the winter to 16-20°C in the summer, the prevalence reached 18% but decreased to only 1% at 41° North, where ocean surface temperatures can range from 8-10°C in the winter to 24-26°C in the summer (Figure 1.5i). As the cod extends its range south of 41° North in sufficient numbers to support a fishery, it appears that *L. branchialis* may be limited by warmer waters.

7.2. Prevalence and intensity of host infection

In species such as cod, whiting and haddock, juvenile fish migrate inshore to nursery grounds until they mature and migrate to deeper offshore waters. As the highest prevalence of *L. branchialis* is usually found in inshore waters, where the habitats of the intermediate and definitive hosts overlap, juvenile fish are the most common definitive host (Table 4). Sproston and Hartley (1941a) found that juvenile whiting less than 10cm in length entering the Tamar Estuary, UK were free from infection. Prevalence increased the longer the fish remained in the estuary. Prevalence was 7.5% for fish 10-15cm in length and 22.3% for fish 15-25cm in length. Similarly, juvenile whiting less than 7.5cm in length entering the Medway Estuary, UK were almost free from infection with a prevalence of 1.8%, but infection was rapid and peaked soon after their inshore migration (Van den Broek 1977). In fish 12.5-14.9cm in length, prevalence was 56.1%. By the time the whiting mature and migrate offshore out of the range of the intermediate host, most fish have outlived the parasite and the prevalence of *L. branchialis* in these older fish is low (Pilcher *et al.*, 1989). Prevalence on flounder was very high (up to 100% in some cases) in all age groups, although the intensity of infection increased from 20.7 in 0+ fish to 149.8 in 3+ fish (Van den Broek, 1979a). As flounder remain inshore throughout the year, where infection is more intense, this result is not unexpected. Around the Isle of Man, the prevalence of *L. branchialis* in different age groups of whiting was similar to other areas (Table 1.4), with younger 0+ fish having a lower prevalence than older 2+ fish, although the prevalence was generally lower in offshore populations (Shotter, 1973b). The pattern of prevalence is different in the northern North Sea where older haddock are the most common definitive host as they are found in the same areas as the intermediate host, lemon sole (Kabata, 1958).

In Norwegian waters, two different populations of cod showed different infection dynamics (Sundnes, 1970). 2+ fish from Bjorgenfjord showed a considerable infection prevalence of 27.3%, whereas fish from Arcto-Norwegian populations were not infected until they were at least 5 years old. 0+ Arcto-Norwegian cod leave coastal waters to feed in the Barents Sea where they are out of the range of infected intermediate hosts and are not exposed to *L. branchialis* until they begin their spawning migration. Prevalence decreased in older Bjorgenfjord fish, suggesting that infection often caused mortality, whereas a slight increase in prevalence in older cod was seen in Arcto-Norwegian populations, indicating that infection did not cause mortality in these older fish and also that there was continuous exposure to infection.

A similar pattern exists on the Northwest Atlantic coast where juvenile cod from inshore waters are more likely to be infected than older cod, due to their proximity to the major intermediate host, the lumpfish. In the waters around Newfoundland, Templeman *et al.* (1976) found that the maximum prevalence of 4.9% was found in intermediate length cod of 31-50cm in length, but declined to 2.2% at fish lengths of 51-90cm, as these older cod are usually found offshore. There was no distinct pattern in the intensity of infection of lumpfish of different ages, as they tend to inhabit coastal habitats where transmission of infection occurs readily, so infection is high on all ages of fish. This is comparable to the pattern of infection found in flounder in UK waters. Jones and Taggart (1998) found a similar pattern of prevalence in cod around the Newfoundland and Labrador coasts, with the greatest prevalence of 9.48% occurring in fish 36-49cm in length and prevalence decreasing at lower and higher fish lengths. However, these authors attribute the highest prevalence at lower fish lengths to a reduction in growth rates of infected cod and not to the migratory behaviour of the fish.

Table 1.4. Studies regarding the prevalence and intensity of *Lernaecera branchialis* infections in varying sizes of different fish hosts.

Location	Species	Size range	Year class	Prevalence (%)	Intensity	Reference
Tamar	<i>Merlangius</i>	10-15cm	-	7.5	-	Sproston and
Estuary, UK	<i>merlangus</i>	15-25cm	-	22.3	-	Hartley, 1941a
North Norway	<i>Gadus morhua</i>	-	>5+	0	-	Sundnes, 1970
		-	6+	5	-	
		-	>7+	10	-	
		-	2+	24	-	
Borgenfjord, Norway	<i>Gadus morhua</i>	-	3+	28	-	
		-	4+	32	-	
		-	5+	26	-	
		-	-	-	-	
Isle of Man, UK	<i>Merlangius</i>	13-28cm	-	19.6	-	Shotter, 1973a
	<i>merlangus</i>	28-38cm	-	36.8	-	
Isle of Man, UK (inshore)	<i>Merlangius</i>	-	0+	2.5	1.0	Shotter, 1973b
Isle of Man, UK (offshore)	<i>merlangus</i>	-	2+	6.7	1.0	
Newfoundland	<i>Cyclopterus lumpus</i>	-	0+	0	0	Templeman <i>et al.</i> , 1976
		-	2+	0.8	1.0	
		30-34cm	-	-	231.25	
		35-39cm	-	-	122.7	
		40-44cm	-	-	93.38	
	45-49cm	-	-	168.40		
	50-54cm	-	-	191.8		
	<i>Gadus morhua</i>	11-30cm	-	2.6	-	
31-50cm	-	4.9	-			
51-90cm	-	2.2	-			
Medway Estuary, UK	<i>Platichthys flesus</i>	-	0+	95.7	20.7	Van den Broek, 1979a
-	-	1+	95.7	46.3		
-	-	2+	97.6	92.1		
-	-	3+	100	149.8		
-	-	4/5+	100	111.6		
-	<i>Merlangius merlangus</i>	<7.5cm	-	1.8	-	
-	<i>merlangus</i>	13-15cm	-	56.1	-	

Table 1.4. Continued.

Location	Species	Size range	Year class	Prevalence (%)	Intensity	Reference
Spitzbergen Bank, North Atlantic	<i>Gadus morhua</i>	<50cm	-	0.18	-	Sanchez-Lizaso and Vasquez, 1987
		51-59cm	-	0.61	-	
		60-68cm	-	1.53	-	
		>69cm	-	0.63	-	
Severn Estuary, UK	<i>Merlangius merlangus</i>	-	0+ 1+	2 10.5	-	Potter <i>et al.</i> , 1988
Spitzbergen Bank, North Atlantic	<i>Gadus morhua</i>	-	3+	0.85	-	Vazquez <i>et al.</i> , 1988
		-	4+	0.75	-	
		-	5+	1.01	-	
		-	6+	1.08	-	
Newfoundland / Labrador	<i>Gadus morhua</i>	<36cm	-	0	-	Jones and Taggart, 1998
		36-49cm	-	9.48	-	
		50-63cm	-	6.46	-	
		64-77cm	-	3.3	-	
		78-91cm	-	1.61	-	
Balsfjord, Norway	<i>Gadus morhua</i>	-	2+3	31	-	Hemmingsen, Halvorsen, and MacKenzie, 2000
		-	4	20.5	-	
		-	5	19	-	
		-	6	35	-	
		-	7+8	35.5	-	

7.3. Seasonality

The seasonal distribution of *L. branchialis* is influenced by the migrations of the host populations. In general, prevalence and intensity of *L. branchialis* on the definitive host is higher in winter than in summer as this is when the definitive hosts migrate inshore and occupy the same habitat as the intermediate hosts (Tables 1.5 and 1.6).

In the southern North Sea, the highest prevalence in whiting occurs in winter due to the increased overlap between the whiting and flounder populations in shallow

coastal areas (Pilcher *et al.*, 1989). However, this pattern of infection of flounder and whiting is not apparent in the northern North Sea at latitudes higher than 57°N where the cycle alternates between lemon sole and haddock (Kabata, 1958; Van den Broek, 1979a). Recruitment on the definitive host increases between May and June, with maximum prevalence occurring around September.

Other European studies have been more localised, examining fish mainly from inshore waters or estuaries. In the Medway Estuary, UK the prevalence on flounder was high throughout the year with a mean of 96.7% (Van den Broek, 1979a). Infection intensity was also high with a mean intensity of 64.9 parasites per infected fish although this did vary throughout the year with peaks in June and December. Whiting entering the estuary in the autumn from offshore waters were generally uninfected, but the infection reached a peak soon after their migration inshore, with the maximum intensity of infection in flounder being recorded 1-3 months after the highest prevalence of mature adult parasites was recorded on whiting (Van den Broek, 1979b). A similar pattern was seen in the Bristol Channel and Severn Estuary, UK where the greatest prevalence on whiting was found in January and February, several months after their migration from offshore (Potter *et al.*, 1988). The greatest prevalence on whiting in the Tamar Estuary was seen in July and August, several months after the year class 0 fish moved into the estuary (Sproston and Hartley, 1941a). Once these fish migrated offshore in the spring the prevalence of *L. branchialis* on whiting in the estuary was 100% although fish that migrated were virtually free from infection. Sproston and Hartley (1941a) concluded that the infected fish tend to linger in the estuary allowing *L. branchialis* to complete its life-cycle and shed its eggs in the inshore waters, increasing the probability of encounter of copepodids with the intermediate host following hatching and development. No

Table 1.5. Studies regarding seasonality in the prevalence of *Lernaeocera branchialis* on different hosts.

Location	Species	Habitat	Prevalence	Seasonality	Reference
Tamar Estuary, UK	<i>Platichthys flesus</i>	Inshore	Low	No	Sproston and Hartley, 1941a
Tamar Estuary, UK	<i>Merlangius merlangus</i>	Inshore	Low – high	Yes	Sproston and Hartley, 1941a
Tamar Estuary, UK	<i>Pollachius pollachius</i>	Inshore	Low	Yes	Sproston and Hartley, 1941a
Plymouth, UK	<i>Merlangius merlangus</i>	Offshore	Low	No	Sproston and Hartley, 1941a
Borgenfjord, Norway	<i>Gadus morhua</i>	Inshore	Moderate	No	Sundnes, 1970
North Norway	<i>Gadus morhua</i>	Inshore	Low	No	Sundnes, 1970
Isle of Man, UK	<i>Merlangius merlangus</i>	Inshore	Low - moderate	Yes	Shotter, 1973a; Shotter, 1973b
Isle of Man, UK	<i>Merlangius merlangus</i>	Offshore	None	No	Shotter, 1973a; Shotter, 1973b
Newfoundland	<i>Cyclopterus lumpus</i>	Inshore	High	No	Templeman <i>et al.</i> , 1976
Newfoundland	<i>Cyclopterus lumpus</i>	Offshore	Low - moderate	Yes	Templeman <i>et al.</i> , 1976
Newfoundland	<i>Gadus morhua</i>	Inshore	Low	Yes	Templeman <i>et al.</i> , 1976
Medway Estuary, UK	<i>Platichthys flesus</i>	Inshore	High	No	Van den Broek, 1979a
Medway Estuary, UK	<i>Merlangius merlangus</i>	Inshore	Moderate - high	Yes	Van den Broek, 1979a
Sweden, south and west coasts	<i>Gadus morhua</i>	Inshore	Low - moderate	Yes	Linderby and Thulin, 1983
Severn Estuary, UK	<i>Merlangius merlangus</i>	Inshore	Low - moderate	Yes	Potter <i>et al.</i> , 1988
Balsfjord, Norway	<i>Gadus morhua</i>	Deep, inshore	Moderate	No	Hemmingsen <i>et al.</i> , 1995
Oosterschelde, Netherlands	<i>Merlangius merlangus</i>	Inshore	Moderate - high	Yes	Van Damme and Hamerlynck, 1992; Van Damme <i>et al.</i> , 1997

Table 1.6. Studies regarding seasonality in the intensity of *Lernaecera branchialis* on different hosts.

Location	Species	Habitat	Intensity	Seasonality	Reference
Newfoundland	<i>Cyclopterus lumpus</i>	Inshore	Low - high	Yes	Templeman <i>et al.</i> , 1976
Newfoundland	<i>Cyclopterus lumpus</i>	Offshore	Low	No	Templeman <i>et al.</i> , 1976
Medway Estuary, UK	<i>Platichthys flesus</i>	Inshore	Moderate - high	Yes	Van den Broek, 1979a
Medway Estuary, UK	<i>Merlangius merlangus</i>	Inshore	Moderate	Yes	Van den Broek, 1979a
North Sea	<i>Merlangius merlangus</i>	Inshore and offshore	Low	Yes	Pilcher <i>et al.</i> , 1989
Balsfjord, Norway	<i>Gadus morhua</i>	Deep, inshore	Moderate	No	Hemmingsen <i>et al.</i> , 1995
Oosterschelde, Netherlands	<i>Merlangius merlangus</i>	Inshore	Low - high	Yes	Van Damme and Hamerlynck, 1992; Van Damme <i>et al.</i> , 1997

significant difference was found in the prevalence on flounder throughout the year. This could be attributed to the ability of the adult parasites to produce more than one pair of egg-strings and the extended incubation of around two weeks (Whitfield *et al.*, 1988)

In the Oosterschelde (SW Netherlands), transmission to whiting can only occur in the spring and autumn when these fish are present in shallow gullies with the intermediate host, flounder (Van Damme and Hamerlynck, 1992; Van Damme, Geets and Hamerlynck, 1997). During the hot summer months, whiting occupy the deeper gullies and in the winter they migrate offshore. The prevalence of infection in whiting peaked at 30-50% in May and 70-90% in December, with a mean infection intensity of 1.6 in December. This high prevalence in whiting is indicative of an area where parasite transmission is highly successful due to the high abundance of flounder as is the case for the Tamar and the Medway Estuaries, UK (Sproston and Hartley, 1941a; Van den Broek, 1979a).

In Balsfjord, Norway, no seasonality was found in *L. branchialis* on cod in samples taken from deep water (ranging from 110-180m) (Hemmingsen, Lile and Halvorsen, 1995). The fjord is relatively isolated with a sill at the entrance and it is likely that the cod have formed a distinct population and that transmission of parasites occurs throughout the year. The lack of seasonality might also be attributed to the lack of major change in temperature throughout the year at these depths.

On the Northwest Atlantic coast in the Newfoundland area, lumpfish are common in coastal waters and during the spring and summer, a prevalence of 100% was generally found, although in southern waters the prevalence was much lower, around 0-20% (Templeman *et al.*, 1976). The intensity of infection in inshore waters was often very high, sometimes as many as 5,000-6,000 parasites per fish and on one

individual 26,700 parasites were estimated (Templeman *et al.*, 1976). The intensity peaked in the summer and tailed off to minimal numbers during winter. Transmission to cod occurs in the summer and autumn when the smaller cod are found close inshore and the prevalence is highest on cod during these months. In offshore waters, the prevalence on lumpfish was much lower, usually around 20-50% and intensity was around 0.1-0.5 parasites per fish, but with no apparent seasonality.

8. Pathogenicity

Infection of the definitive host by adult female *L. branchialis* has been observed to induce anaemia and loss of weight in its host; reduces fat content, liver somatic index, haematocrit levels and reproductive capacity; and causes localised sores, scarring and mortality (Kabata, 1958; Mann, 1970; Van den Broek, 1978; Hislop and Shanks, 1981; Moller, 1983; Khan and Lacey, 1986; Khan, 1988; Khan *et al.*, 1990; Van Damme, Ollevier and Hamerlynck, 1994; Smith *et al.*, 2007). In comparison, *L. lusci* is suggested to be less pathogenic towards its definitive host (Van Damme *et al.*, 1994), whilst Eiras (1986) and Brinkworth *et al.* (2000) failed to find evidence for the pathogenicity of *L. lusci*. Mortality of infected definitive hosts is greatest amongst the smallest size classes and Khan (1988) reported a mortality of 43% in infected cod 36-41cm, compared to 31% in fish >54cm. Most deaths occurred in the first 4 months after infection and were largely associated with multiple infections. Death of young fish was associated with emaciation, haemorrhage of the tissue adjacent to the holdfast, open lesions, severe necrosis and low haemoglobin levels. However, in older fish death probably resulted from occlusion of the ventral aorta and / or branchial arteries. Sundnes (1970) found that fish <40cm in length showed a significant decrease in condition factor and haematocrit values, whereas fish >40cm showed no significant

difference in condition between infected and uninfected fish, indicating that older fish are more able to cope with the infection.

Mature parasites often protrude from the gills, preventing opercular closure and putting pressure on the surrounding area, leading to atrophy of sections of gill (Van den Broek, 1978). Adverse effects in whiting have been shown to include small localised sores, decreased liver lipid content, complete emaciation and death of the host (Van den Broek, 1978; Van den Broek, 1979a). In cod, the early stages of *L. branchialis* infection induce local gill hyperplasia, large intravascular thrombus formation and a cellular immune response in cardiac and branchial tissues (Smith *et al.*, 2007). It has been suggested by some authors that a decrease in haematocrit value and liver lipid content is an indication of a lower metabolic rate, which in turn may result in reduced swimming speed, increased susceptibility to predation and lower prey uptake (Van Damme *et al.*, 1994; Van den Broek, 1978).

Generally, cod parasitised with *L. branchialis* have a lower condition factor and growth rate than uninfected fish, especially in younger fish and those with multiple infections. Khan (1988) found that young cod around 33cm in length and harbouring three or more parasites had a significantly lower condition factor than control fish after four weeks. In a different study (Khan and Lee, 1989) cod showed lower increments in body length and weight over a period of 10 months, with infected fish weighing up to 28% less than controls. However, after the first 10 months infected fish gained weight at a comparable rate to controls and at 16 months, after the parasites had reproduced, no significant difference in weight was apparent. This indicates that although *L. branchialis* can significantly reduce condition and growth in cod, those fish that outlive the parasite may eventually catch up with uninfected fish. Adult cod infected with one or two parasites

initially showed an increase in food consumption and weight gain compared to controls, although condition factor and food conversion efficiency were lower throughout the period of study (Khan, 1988; Khan and Lee, 1989). Presumably this compensates for the effect of the parasites, resulting in a transitory weight gain. Another study showed that this compensatory growth occurs through the consumption of more food in the autumn months rather than during the winter (Khan, Barker and Lee, 1993). A further explanation may be that resistance to *L. branchialis* infection is costly, in terms of growth and maturation, as Lysne *et al.* (2006) found that caged cod infected with one *L. branchialis* had a higher growth rate than fish that remained uninfected throughout the study period.

There are several reports of abnormal behaviour of fish infected with *L. branchialis*. Khan (1988) noted that infected fish were hyperactive and swam in an erratic manner, remaining at the surface because of the excess air in the swim bladders. Sproston and Hartley (1941a) suggested that the parasites cause metabolic alterations resulting in abnormal uptake of fluid and that these fish may remain in low salinity estuarine environments. These behavioural abnormalities may increase the likelihood of predation or capture by fishing and can therefore have an impact on fish populations.

Infection with *L. branchialis* has also been shown to affect gonadal maturation. According to Hislop and Shanks (1981) fecundity was 21% lower in infected haddock than in uninfected fish and Kabata (1958) found that infected female haddock had lower gonadal weights. Templeman *et al.* (1976) and Khan (1988) showed evidence that infection with *L. branchialis* delayed gonadal maturation in cod. In a study by Khan (1988), only 19% of fish infected with *L. branchialis* were sexually mature and only those fish with single infections were mature. In comparison, 64% of control fish were

mature. In the wild, this delayed maturation and reduced fecundity could lead to changes in the population dynamics of the infected fish populations over time. This may be particularly pertinent for species such as cod which are under considerable current pressure as a result of overfishing.

Although most studies have shown considerable pathogenicity of *L. branchialis*, some authors have reported only minimal changes (Sproston and Hartley, 1941a; Sherman and Wise, 1961; Khan and Lacey, 1986). It is likely that these differences can be attributed to the time of year that sampling took place. Older infected fish examined in the summer, around 10 months after infection will have had time to adjust to the infection and any effects may not be readily apparent.

It appears that infected fish show indications of chronic stress. Khan (1988) found that most infected fish 30-60cm in length, transported in tank trucks during the summer, died within 24 hours. Mann (1952) reported that infected fish are less able to utilise oxygen and it could be assumed that these fish would be more likely to die than uninfected fish if oxygen was limited as their oxygen requirements would be higher. Sub-adult cod harbouring infections and exposed to low hydrocarbon concentrations were also more likely to die than uninfected fish (Khan, 1988). Additionally, it has been shown that fish harbouring secondary infections concurrent with *L. branchialis* are more likely to succumb (Khan and Lacey, 1986). Khan and Lacey (1986) and Khan (1988) infected sub-adult cod with dual infections of *L. branchialis* and a blood protozoan, *Trypanosoma murmanensis* Nikitin. About 60% of the sub-adult fish died and the surviving fish were emaciated to such an extent that their survival in a natural environment would be unlikely. Surviving fish had pale gills, significantly lower haemoglobin concentrations, condition factors and liver somatic indices than uninfected

fish or those infected only with *L. branchialis*. With the chronic stress associated with *L. branchialis* infection, fish subjected to any form of secondary stress, such as disease infection or poor water quality, are unlikely to survive.

Although adult *L. branchialis* have been shown to have a major effect on their definitive hosts, little or no adverse effects have been seen in hosts infected with the juvenile and pre-metamorphic stages of the parasite. Juvenile *L. branchialis* feed on the gill tips of the host, but do not penetrate the heart or blood vessels. Up to 700 larvae on flounder and over 26,000 larvae on lumpfish have been reported, but with no apparent ill-effects (Templeman *et al.*, 1976; Kabata, 1979).

9. Concluding remarks

It is clear from the literature that *Lernaeocera branchialis* is capable of severely affecting the health of gadoid fish, particularly juveniles, and is therefore likely to pose a considerable risk to the health of pressured and recovering wild gadoid populations and cultured gadoids. Factors that increase these risks include its high fecundity, wide distribution in northern coastal waters, and the considerable host impact of individual adult parasites. Despite the potential impact of this pathogen, there are numerous research areas that require more detailed examination. These include: 1) host-parasite interactions, both in terms of host immune responses and the immuno-modulation of such responses by the parasite; 2) pathology and pathogenesis in intermediate and final hosts; 3) epidemiological studies, which are key to assessing the risks to fish populations associated with this pathogen and developing improved tools for management and control; 4) parasite behaviour and in particular host location and settlement behaviour and the cues that drive them; 5) population genetics studies, which may allow for the recognition of different populations and thereby reveal any existing

differences in host preference, environmental optima and pathogenicity between genotypes; 6) physiological parameters *e.g.* feeding, digestion, respiration etc; 7) the development of management and control strategies including assessment of the efficacy of existing chemotherapeutants *e.g.* emamectin benzoate (SLICE, Schering Plough). In a situation where many wild gadoid fisheries are under increasing pressure, demand for these fish products remains high. As a result, the emerging gadoid culture industry is expanding rapidly to meet demand. Current technologies, however, largely favour the use of coastal sites where the likelihood of infection by this parasite is highest. There is, therefore, an urgent need to anticipate the health problems that infection by this parasite may engender and to develop contingency plans for the management and control of this widespread and potentially devastating pathogen.

10. Research objectives

Considering these aspects of the biology and host-parasite interactions of *L. branchialis* that require further investigation, the research objectives for this study are as follows:

- 1) Determine egg hatching and moult timings for the juvenile free-swimming stages of *L. branchialis*
- 2) Re-describe the juvenile free-swimming stages of *L. branchialis*.
- 3) Develop techniques involving confocal microscopy for the purpose of generating taxonomic descriptions.
- 4) Compare light microscopy and confocal microscopy for the purpose of producing taxonomic descriptions.

- 5) Investigate the role of fish-derived chemical cues for host location in pre-metamorphosed adult female *L. branchialis*.
- 6) Determine the source of fish-derived chemical cues used for host location in pre-metamorphosed adult female *L. branchialis*.
- 7) Quantify the free-swimming behaviour of pre-metamorphosed adult female *L. branchialis*.
- 8) Quantify the free-swimming behaviour of pre-metamorphosed adult female *L. branchialis* in the presence of fish-derived chemical cues.

Chapter 2 – General materials and methods

1. Fish collection and maintenance

All the fish that were required for experimentation were taken from Longannet power station situated by the Forth Estuary at Kincardine, Scotland (56° 02' 53" N, 3° 40' 59" W). They were either collected directly from the wash-off from the water intake screens or recovered from skips containing the waste from the screens. As the water intake screens are particularly stressful and damaging to the fish, mortalities were high, especially in gadoids, although this did not affect the collection or the subsequent culture of *L. branchialis*. The fish (gadoids and flatfish) were transported to the marine aquarium facility at the University of Stirling in large plastic bags with aeration and retained in a 400L recirculation tank at ambient temperature with a bio-filter attached to maintain water condition. They were fed *ad lib* with a combination of frozen ragworm (Seabait Ltd, Newcastle Upon Tyne) and sinking trout pellets (Europa 15, Skretting).

2. Parasite collection and culture

To collect pre-metamorphosed adult female *L. branchialis*, 5-10 flounder (*Platichthys flesus* (L.)) were moved to a 100L static tank kept in a constant temperature room which was maintained at 10°C. A bio-filter was attached to maintain water condition and a fine 50µm mesh gauze was connected to the end of the intake pipe to ensure that parasites that had left the host were not sucked into the filter. Each day, all the water from the tank was siphoned into another 100L tank and filtered through a 50µm sieve to remove any adult *L. branchialis* that had left the intermediate host. This ensured that all the parasites used in the experiments had only recently left the intermediate host and would

have high energy levels, giving them the greatest opportunity to show a response to the chemical cues (to which they would subsequently be exposed to).

To culture the juvenile stages of *L. branchialis*, egg-strings were dissected from gravid female parasites collected from infected whiting (*Merlangius merlangus* (L.)) and cod (*Gadus morhua* L.). These were then maintained under aeration in 500ml beakers kept in a Binder environmental cabinet at 10°C. Once the eggs began to hatch they were placed in a beaker of clean sea water (35 ‰) and after a period of time (1-24 hours) the egg-strings were transferred to another beaker of clean sea water, leaving behind a ‘batch’ of nauplii. These batches were then used for experiments as either nauplii or copepodids, depending on how long they were maintained. When chalimus stages were required they were dissected from the gills of dead flounder.

3. Sea water collection

As the sea water in the aquarium was heavily re-circulated and artificial sea water was not particularly suitable for the culture of copepod parasites, clean sea water was collected from the beach at East Wemyss, Fife, Scotland (56° 09' 35" N, 3° 03' 36" W). Each sample of water was checked with a salinometer (Atago S/Mill, Japan) to ensure that it was full strength sea water (35 ‰) before being transported in plastic containers to the University of Stirling aquarium and kept in a 400L tank with aeration until required. This water was used for all the parasite cultures and the behavioural experiments, including the production of the chemical cues to ensure consistency throughout the experiments.

4. Production of chemical cues

Four species of fish were selected to test the response of *L. branchialis* to chemical cues: cod and whiting as definitive hosts; flounder as an intermediate host; and brown trout (*Salmo trutta* L.) as a freshwater non-target species. For each species of fish, four potential cue sources were collected: fish conditioned water, mucus, flesh and faeces. This gave a total of 16 different cues plus a sea water control. For the three marine species, fish conditioned water was prepared by maintaining live fish in sea water for 24 hours at a ratio of 10g of fish per 1L of water. Trout were kept in fresh water at the same ratio of fish:water and then salt was added (Instant Ocean synthetic sea salt) to make full strength sea water (35 ‰). Mucus was collected from several freshly killed fish by rinsing the fish with 100mM ammonium bicarbonate (Ross *et al.*, 2000) and then diluting it in 1L of sea water. For the flesh cue source, five grams of fish flesh was homogenised and added to 1L of sea water. Faeces were collected by filtering the water from a tank of fish kept for 24 hours and then adding the faeces to 1L of sea water.

Specific methods for recording videos of parasite movements in response to the chemical cues are described in Chapters 4 and 5.

5. Video preparation

Once digital videos of *L. branchialis* behaviour had been recorded, the data were prepared for analysis using KSRun Macro Execution Environment Rel. 3 (Carl Zeiss, Inc.) according to the following procedure:

1. Individual frames were extracted from the video file using Irfanview software Version 3.98 with the “extract all frames” command and were saved as a set of individual bitmap images.

2. A macro was employed in KS300 to prepare the image set for track digitisation, containing the following procedures (see Appendix A):
 - a. Median filter – applied to each image in the set and also to a baseline chamber image (without a parasite), to remove any “pixel noise” introduced during video capture.
 - b. Shade correction – each image is compared to the baseline image and the differences between the pixel values of the two images are stored as a separate image. This removes the image background leaving just the parasite in the image.
 - c. Segment analysis – any pixel above a set threshold value is given a new standard value. The threshold value is determined for each image set based on the colour / contrast of the parasite. This is used to highlight the parasite in the image making it easier to detect.

6. Paratrack track digitisation and analysis software

To extract and analyse the behavioural information from the digital video files a software program was developed called “Paratrack”. This software was programmed using the Borland Developer Studio Version 10.0.2166.28377 Update 1 (Borland Software Corporation) and was coded in the Pascal programming language (see supplementary CD for Paratrack software and code). Although commercial software packages are available for the digitisation and analysis of animal movements (e.g. Motion Analysis Corporation, Santa Clara, CA, USA; Ethovision, Noldus Information Technology, Wageningen, The Netherlands), their cost is prohibitive for individual studies. Also, Paratrack was designed specifically to analyse the data from the *L.*

branchialis behaviour experiments and, therefore, was tailored to meet the requirements of these experiments. The two different types of experimental chamber used were a Y-shaped choice chamber, in which the parasites were tracked in 2D, and a cuboid arena in which the parasites were tracked in 3D (see Chapters 4 and 5 for details). The key features of Paratrack are as follows:

- Extraction of parasite co-ordinates in either two or three dimensions from data sets of images containing individual frames from video files.
- Generation of images displaying the parasite track.
- Recognition of individual images where the parasite is not detected and manual marking of the parasite location.
- Analysis of co-ordinate data sets to calculate behavioural parameters including zone analysis, velocities, distance travelled, activity analysis, bout analysis, headings, turn angles and meander. All of these parameters were taken from existing software (Ethovision, Noldus Information Technology, Wageningen, The Netherlands).
- Calculation of a fractal dimension for each track, characterising the complexity of the track.

6.1. Paratrack main window

The main Paratrack window allows the user to select the image set to be analysed, select analysis options, perform tracking operations and provides access to the other Paratrack windows (Figure 2.1).

Functions that can be performed from the main window are as follows (letters refer to the labels in Figure 2.1):

- a) Add and remove image file sets to be analysed. Multiple files can be selected by holding Ctrl or Shift while clicking with the mouse. The “Clear list” button removes all the files from the file set.
- b) Clicking “Set min co-ords” or “Set max co-ords” opens a window that allows the user to set the limits of the analysis area in the image. The co-ordinates defining this area are entered into the four boxes when the user clicks on the top left and bottom right corners of the analysis area. The “3D arena setup” button opens a new window to prepare the arena for 3D tracking (see Section 6.2).
- c) This button opens a “Parasite colour” window displaying the first image in the set. Clicking on the parasite stores the parasite’s colour and is used to discriminate the parasite from the background image once tracking begins.
- d) A detection threshold can be set, which is the range of colour shades lighter or darker than the parasite colour that will be recognised as the parasite. This should be altered manually by trial and error to ensure that the background image is not identified as the parasite.
- e) When tracking in 2D colour options can be set, which allow different portions of the track to be identified with different colours. The frame rate of the original video and the frequency of colour change required are entered into the appropriate boxes and the legend box is ticked to draw a legend on the tracking image identifying the time periods for each portion of the track.

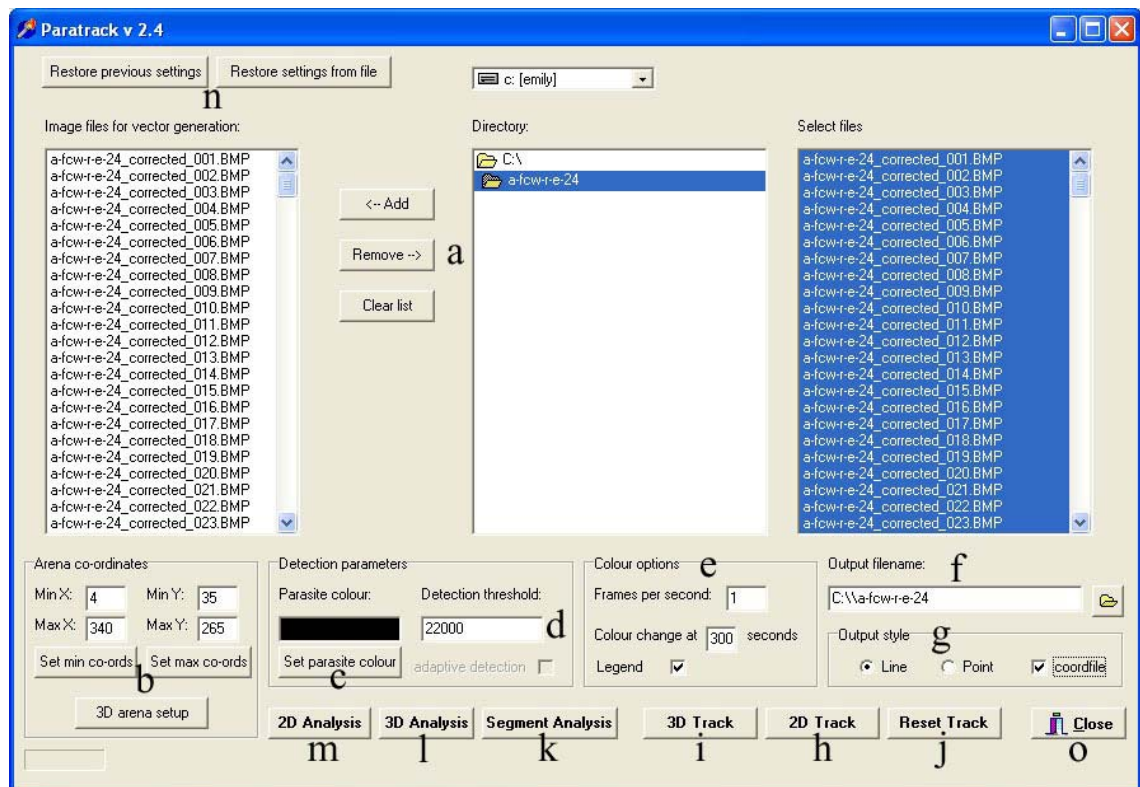

Figure 2.1. The main features of the Paratrack front window. Functions are as follows: (a) add and remove image files, (b) arena setup, (c) set parasite colour, (d) set detection threshold, (e) track colour options, (f) specify path and filename, (g) set output style, (h) start 2D tracking, (i) start 3D tracking, (j) reset track, (k) segment analysis, (l) open 3D analysis window, (m) open 2D analysis window, (n) restore previous settings, (o) close Paratrack.

- f) A path and filename for the output files is chosen by clicking on the button with the folder icon. This opens a window allowing the user to navigate to the folder chosen to save the output and an output filename can be entered.
- g) The output style of the tracking image can be set to either point or line style and the “co-ord file” checkbox can be checked to generate a file of x,y or x,y,z co-ordinates.
- h) This button begins 2D tracking.

- i) This button begins 3D tracking.
- j) If the tracking process is interrupted and needs to be restarted the “Reset track” button allows the tracking process to start again from the beginning.
- k) This performs a simple segment analysis on the image file set, using the information provided in the parasite colour and detection threshold boxes. Any pixel detected within the threshold colour range is given a new colour value of black. The new images are saved as the original filenames with “_segmented” appended to the end of the filename.
- l) This button opens the 3D analysis window.
- m) This button opens the 2D analysis window.
- n) If the program is closed the settings entered in the previous session can be restored by clicking on the “Restore previous settings” button. If tracking needs to be repeated for a previous experiment the program settings can also be loaded from the output file generated for the previous run by clicking on the “Restore settings from file” button and selecting the required file.
- o) Once the session is complete Paratrack can be closed by clicking this button.

6.2. 3D arena setup

The 3D setup window is accessed from the main window by clicking the “3D arena setup” button (Figure 2.2). This is used to set the parameters required for 3D tracking. The 3D tracking arena uses a mirror tilted at 45° to project the vertical movements of the parasite to a video camera positioned above the arena (see Chapter 5 for more details). The features of this window are as follows (the letters refer to the labels in Figure 2.2):

- a) Arena display window. This displays the first image in the set to be analysed and is used to set up the arena boundaries and calibration. The arena is visible in the right portion of the image and the mirror in the left portion.

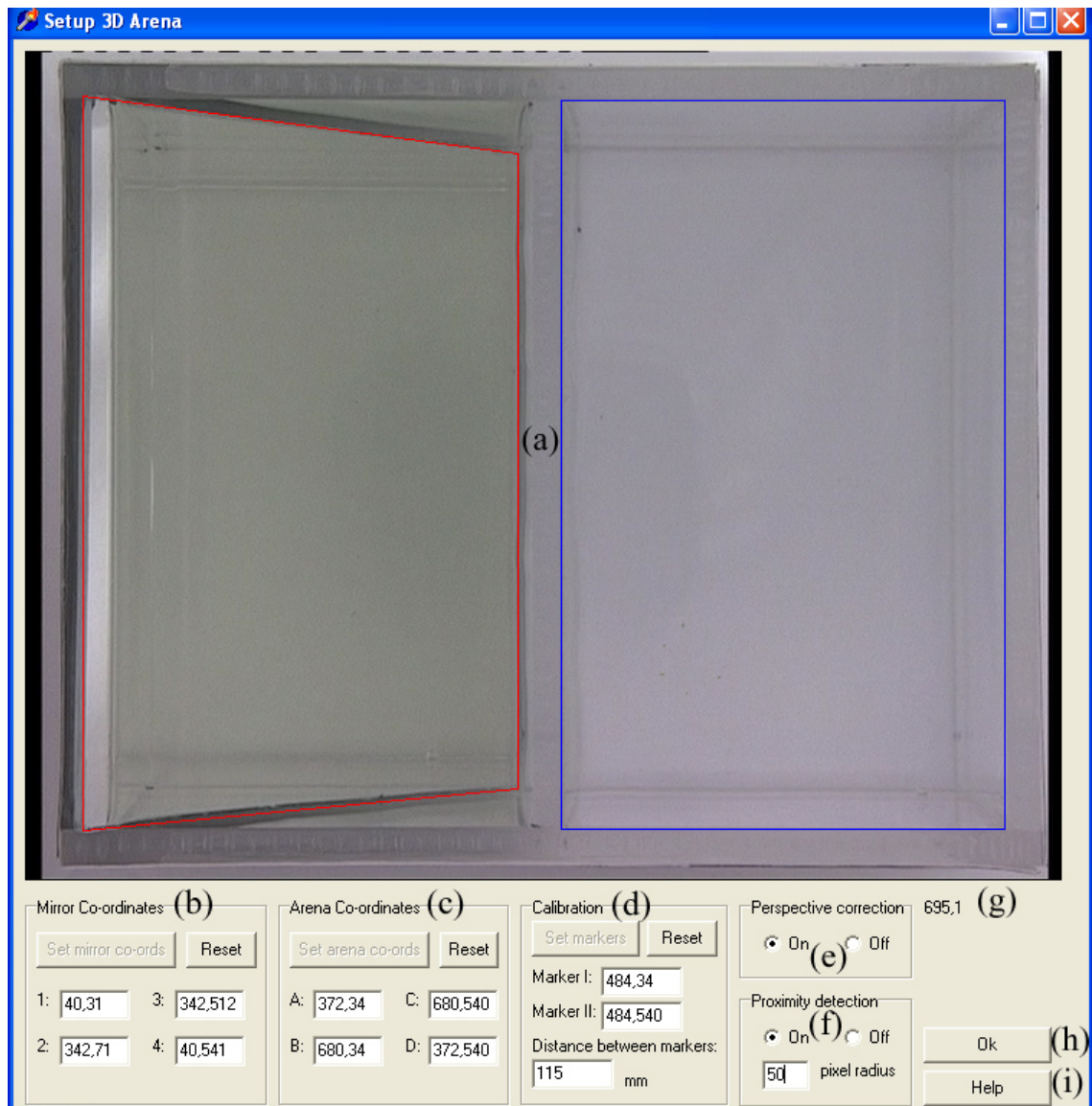

Figure 2.2. The Paratrack 3D setup window. Functions are as follows: (a) arena display window, (b) set mirror boundaries, (c) set arena boundaries, (d) set calibration factor, (e) perspective correction, (f) proximity detection, (g) cursor co-ordinates, (h) return to main window, (i) setup help.

- b) The boundaries of the mirror analysis area are set by clicking the “set mirror co-ords” button and then clicking on each corner of the mirror, which draws a red box in the arena display window marking the boundaries of the detection area. The co-ordinates can be fine tuned by altering them manually in the boxes. If the boundary is incorrect it can be reset by clicking the “reset” button.
- c) The boundaries of the arena analysis area are set in the same way as the mirror analysis area and a blue box is drawn marking the arena boundaries.
- d) A calibration is required for the perspective correction and also to convert pixel distances into real distances when the track is analysed. Two markers are set which are separated by a known distance by clicking the “Set markers” button by and clicking twice in the arena display window. The distance between the markers is entered into the appropriate box. The correction factor is then calculated from the following equation:

$$cf = \frac{D}{n}$$

Where D = distance between markers in mm, n = number of pixels between markers and cf = correction factor. This correction factor can then be multiplied with distances measured in pixels to convert them to distance in millimetres.

- e) As objects appear reduced in size the further away they are from the camera this needs to be corrected, otherwise the resulting track would be distorted. By turning the perspective correction on, the measured parasite co-ordinates in each image are corrected to account for this distortion. The perspective correction is calculated by using the top of the arena as a baseline and

assuming that objects appear reduced in size the further they are from the top of the arena. Measurements of the size of an object of a known size at different distances from the top of the arena revealed that objects appear reduced in size according to the following logarithmic regression:

$$S = 100e^{-0.0019d}$$

Where S = size of the object as a percentage of the original size as it appears at the top of the arena and d = distance from the top of the arena in mm. To correct the x and y co-ordinates of the parasite, the distance of the parasite from the centre of the image is multiplied by the reciprocal of S to give its real distance from the centre of the image. To correct the z co-ordinate of the parasite, the distance of the parasite from the mirror plus its distance from the top of the arena is multiplied by the reciprocal of S to give its real distance from the top of the arena. To verify the perspective correction, the co-ordinates for a series of points in the arena were compared to those calculated in Paratrack with and without perspective correction turned on (Table 2.1). Using the perspective correction significantly increases both the accuracy and precision of parasite co-ordinates measured in Paratrack.

Table 2.1. Mean deviations from actual co-ordinates of co-ordinates measured in Paratrack with perspective correction turned on and off.

	Mean deviation (mm) \pm standard deviation		
	x	y	z
Perspective correction off	9.7 +/- 11.3	1.1 +/- 11.4	9.1 +/- 10.7
Perspective correction on	-1.1 +/- 0.5	-0.2 +/- 1.3	-0.4 +/- 3.3

- f) By turning proximity detection on, Paratrack will search a given radius from the location of the parasite in the previous image. This significantly reduces the time required to find the parasite in each image as only a small portion of the image is being scanned. This search radius can be altered by changing the value in the pixel radius box. If the parasite moves rapidly and the search radius is not wide enough, it should be increased and the parasite detection restarted. If the parasite moves slowly the search radius can be reduced as a small search radius reduces the likelihood of image “noise” being incorrectly identified as the parasite.
- g) As the mouse pointer is moved over the image, the image co-ordinates are displayed here. This can be useful for setting the arena co-ordinates and calibration markers.
- h) Once the 3D arena has been set up correctly, clicking the “Ok” button will close the 3D arena setup window and return to the main window.
- i) Clicking the “Help” button displays an image indicating where the corner co-ordinates of the mirror and arena should be located.

6.3. Tracking

Once the image set has been loaded into Paratrack and the arena has been set up, tracking can be started by clicking either the “2D track” or “3D track” button as appropriate. Each image is scanned for the parasite, with the scan area being limited by the arena boundaries and the proximity detection radius. If the parasite is not detected in any image, tracking is paused and the image is displayed, allowing the user to manually mark the parasite in the image and save it (Figure 2.3). The arena boundaries and proximity detection box are displayed to help identify the location of

the parasite, which can usually be faintly seen. The parasite is marked by clicking on its location which will draw a dot the same colour as the parasite colour specified in the main window. Once the image has been saved, tracking can be continued from where it paused by clicking the appropriate track button once again.

The progress of the analysis can be seen from the progress bar at the bottom of the main window and the current image being analysed is displayed in the bottom left

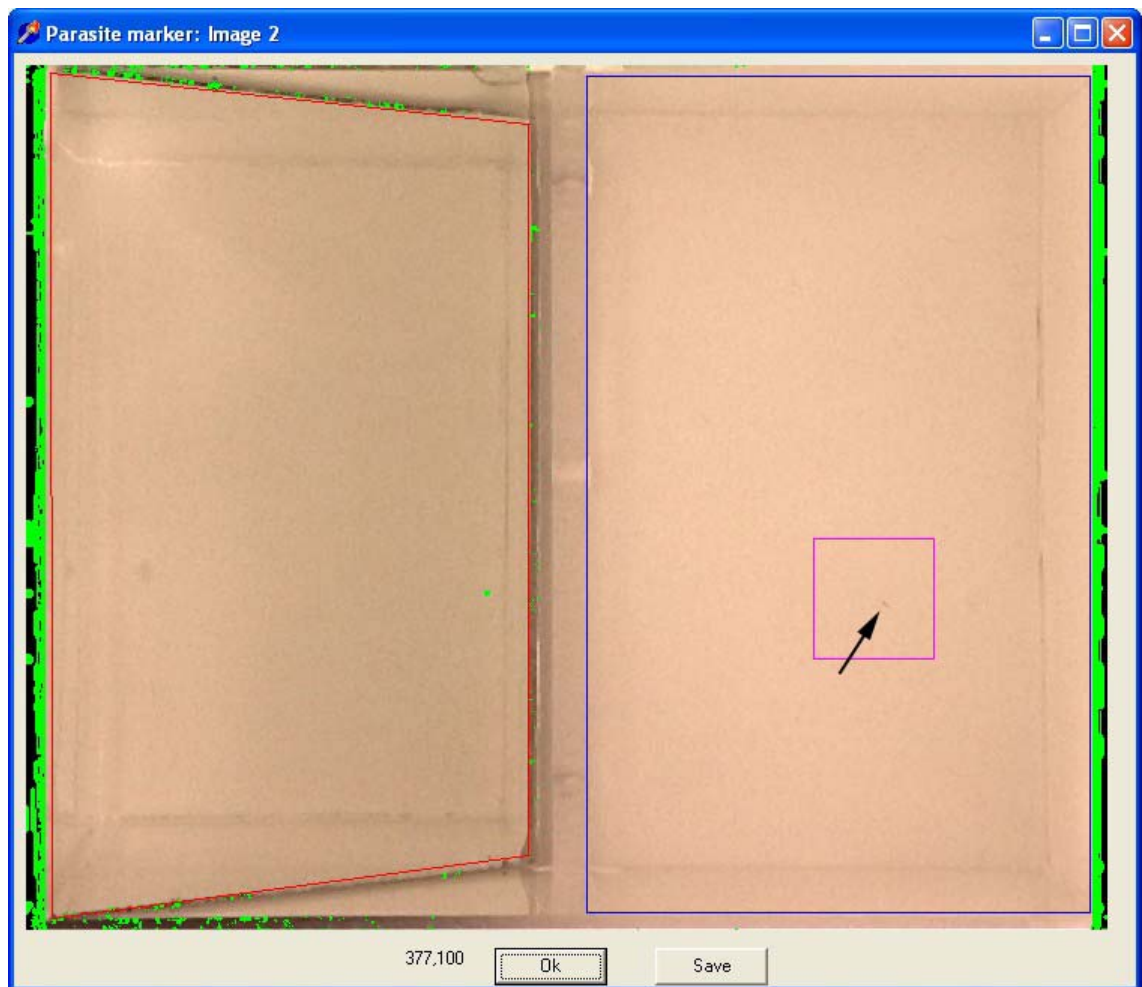

Figure 2.3. The Paratrack parasite marker window. The red and blue boxes show the mirror and arena boundaries; the purple box indicates the proximity range; the arrow shows the position of the undetected parasite.

corner. As the parasite is tracked, its path is drawn in the track display window and once tracking is complete, the image is saved as a bitmap with the filename and path specified earlier, along with a co-ordinate file (if selected) of the same name saved as a .txt file (Figure 2.4). For 2D tracking, the co-ordinates written to file are taken directly from the image, but for 3D tracking, the origin of the co-ordinate system is the top, left, lower corner of the arena and the co-ordinates taken from the image are converted to these axes after the perspective correction is applied (if selected).

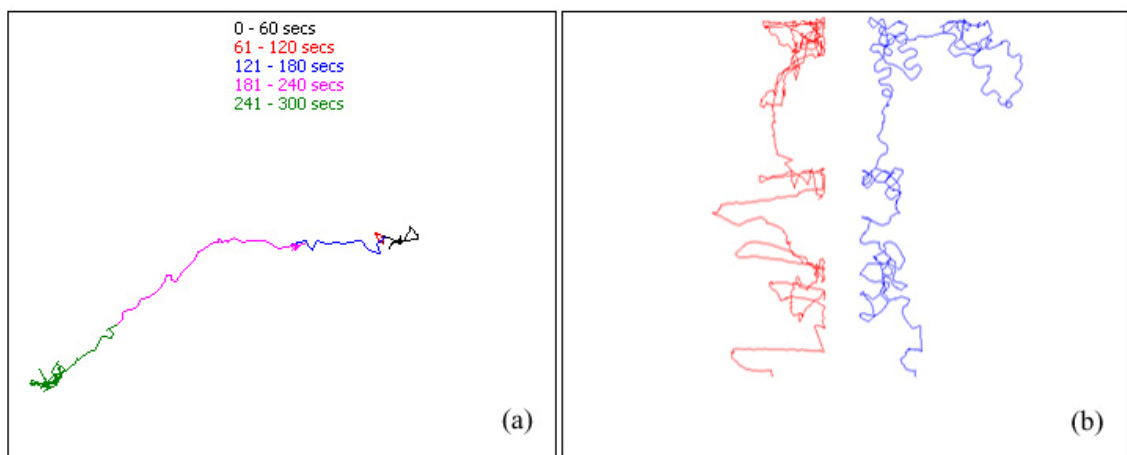

Figure 2.4. (a) A 2D track image generated in Paratrack. The parasite track is divided into 60 second portions coloured according to the legend. (b) A 3D track image generated in Paratrack. The blue track shows the top view (x,y) and the red track shows the side view visible in the mirror (y,z).

6.4. Track analysis

Once a 2D track has been generated it can be analysed from the 2D track analysis window (Figure 2.5) which is opened from the main window by clicking the “2D analysis” button.

The functions available from this window are (letters refer to the labels in Figure 2.5):

- a) Selection of the file to be analysed. The filename is double clicked and entered into the box below.
- b) The data set is normalised so that arena orientation and cue arm (the arm of the Y-chamber that the chemical cue is introduced into) are the same in each replicate (see Chapter 4). To do this, the orientation and cue arm are selected in the drop down menus and the image size is entered, before the “Normalise” button is clicked, which transposes the data into the correct format. The new data are saved in a new file with the original filename with “_normalised” added to the end. The normalised data can be viewed by clicking the “View data” button which opens a new window with the co-ordinate data displayed as an image.

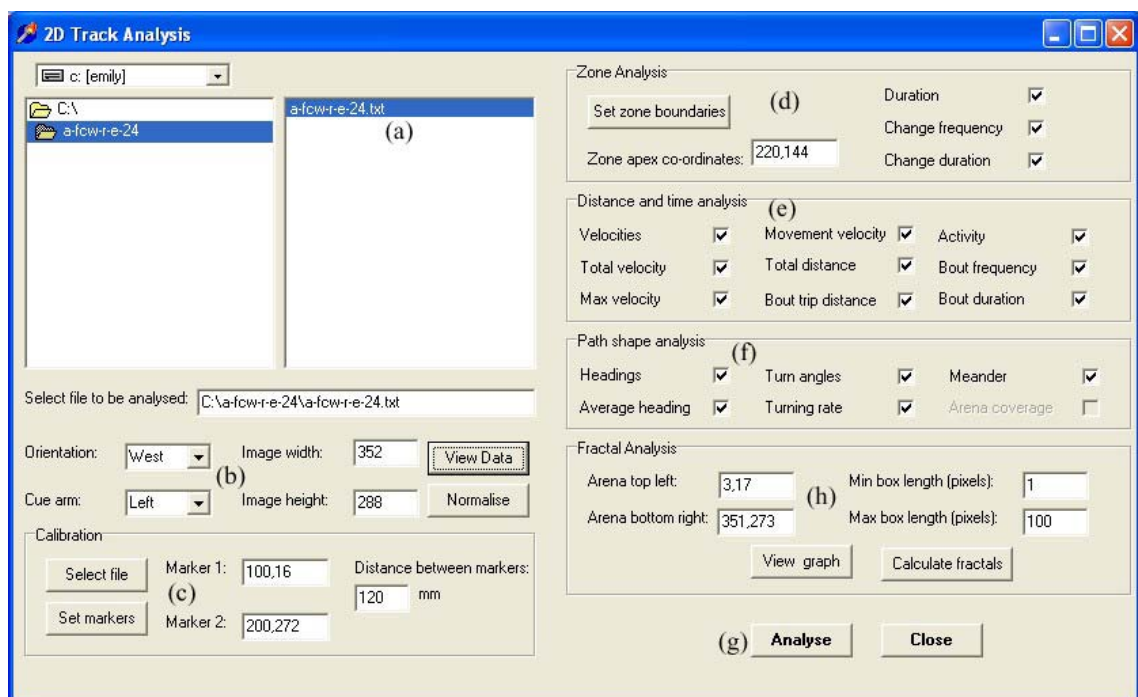

Figure 2.5. The Paratrack 2D track analysis window. (a) file selection box, (b) data normalising options, (c) calibration options, (d) zone analysis setup, (e) distance and time analysis options, (f) path shape analysis options, (g) begin analysis button, (h) fractal analysis options.

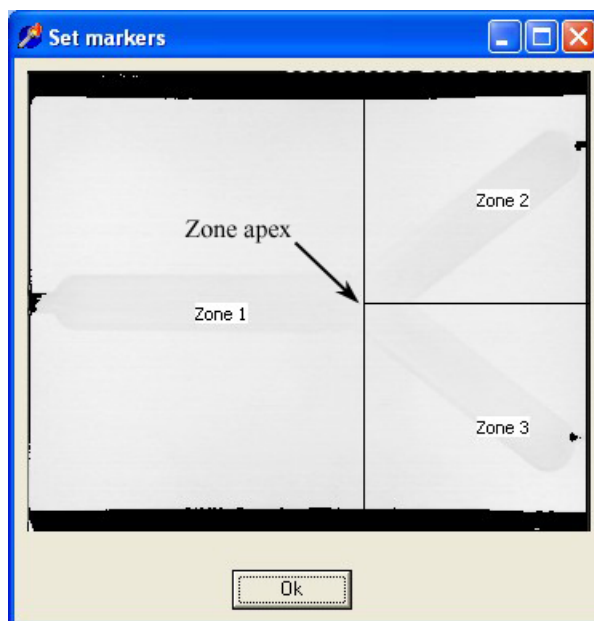

Figure 2.6. The Paratrack zone boundary window with the arena divided into three zones: zone 1 = mixed zone, zone 2 = cue zone, zone 3 = control zone. The zone apex point is used to define the zone boundaries.

- c) To calculate behavioural parameters in empirical units, rather than pixels, the data need to be calibrated. One of the files from the image set is selected using the “Select file” button. Clicking the “Set markers” button opens the image file and two markers are chosen by clicking on the image which are separated by a known distance. The distance between the two markers is then entered into the appropriate box. The calibration factor is calculated in the same way as in Section 6.2. The correction factor is then multiplied with behavioural parameters calculated during analysis to give the output in millimetres instead of pixels.
- d) Different zones can be defined within the arena which allows parasite activity between these zones to be calculated. Clicking “Set zone boundaries” opens a window displaying the image used for calibration (Figure 2.6). Clicking on

this image provides co-ordinates for the apex of the 3 zones within the chamber (see Chapter 4). These co-ordinates are displayed in the 2D track analysis window and can be altered here to fine tune the zone boundaries.

- e) Distance and time parameters are calculated by checking the appropriate check boxes. These parameters are: velocities (a time series of velocity between each data point), total velocity (average velocity), movement velocity (average velocity not including periods of no movement), maximum velocity, total distance (distance travelled during experiment), activity (time spent moving and immobile), bout frequency (number of swimming and immobile bouts), bout duration (average length of swimming and immobile bouts) and bout distance (average distance travelled during swimming bouts). Velocity and distance parameters are calculated using basic trigonometric functions for each pair of co-ordinates in the data set (see Appendix B for definitions and formulae).
- f) Path shape parameters are calculated by checking the appropriate check boxes. These parameters are: headings (a time series of headings in degrees between each data point), average heading, turn angles (a time series of the amount of turn in degrees between each data point), turn rate (average turn rate in degrees/ sec) and meander (average turn rate in degrees/ mm) (see Appendix B for definitions and formulae).
- g) Once all the appropriate check boxes have been checked the “Analyse” button is clicked and all the behavioural parameters are calculated. The resulting output is saved in a new file with the original file name with “_analysed” added to the end.

h) Fractal dimensions are calculated using the “box counting” method (Seuront *et al.*, 2004; Uttieri *et al.*, 2005). This method finds the number of boxes of length λ required to cover the track (Voss, 1993) by superimposing a regular grid of boxes of length λ on the image and counting the number of occupied boxes. The procedure is then repeated using different values for λ up to the size of the image (Figure 2.7). The number of occupied boxes increases with decreasing box size according to the following power law relationship (Loehle, 1990):

$$N(\lambda) = k \lambda^{-D}$$

Where λ = box size, $N(\lambda)$ = number of boxes occupied by path, k = constant and D = fractal dimension. D is estimated from the slope of the linear trend of the log-log plot of $N(\lambda)$ versus λ (Sreenivasan *et al.*, 1989; Wijesekera, 1996), and gives an estimate of track sinuosity or complexity. A higher fractal dimension indicates a more complex track. In theory, extreme cases are defined by linear and Brownian movement, giving fractal dimensions of 1 and 2 respectively, and all other examples should fall between these two extremes. To calculate the fractal dimension in Paratrack the image coordinates of the top left and bottom right corners of the arena are entered and also the minimum and maximum side length of the boxes (λ) that are overlaid onto the track. Paratrack calculates a range of λ values in a 2^n series (Soddell and Seviour, 1995; Sandau and Kurz, 1996) and in this study the minimum λ value was 8 pixels (approximately the length of the parasite) and the maximum λ value was 256 pixels (the largest 2^n value closest to the length of the shortest axis of the arena).

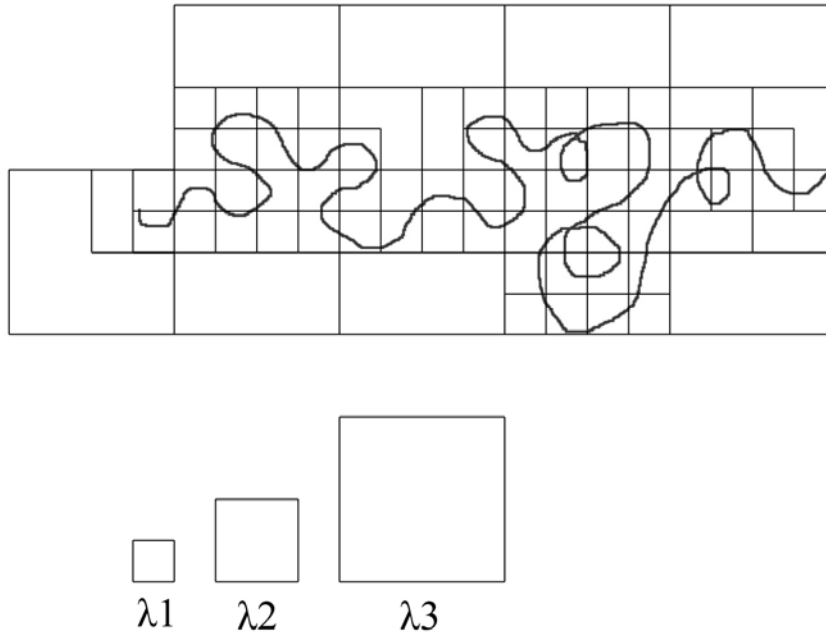

Figure 2.7. Schematic diagram of the box counting method used to estimate fractal dimensions where boxes of increasing size λ are superimposed over the track and the number of occupied boxes is counted.

This ensured that an appropriate range of scales was covered to reliably estimate D (Turchin, 1996; Halley *et al.*, 2004), as λ values smaller than the size of the parasite may have resulted in errors due to turning of the parasite while stationary or noise introduced from the video capture. The “Calculate fractals” button is clicked and a bitmap image is generated, showing the log plot of box size versus box number and estimated fractal dimension and corresponding r^2 value from the linear regression (Figure 2.8). The graph can be viewed by clicking the “View graph” button. The counts for each box size are saved in a separate file with the original file name with “_fractal” added to the end.

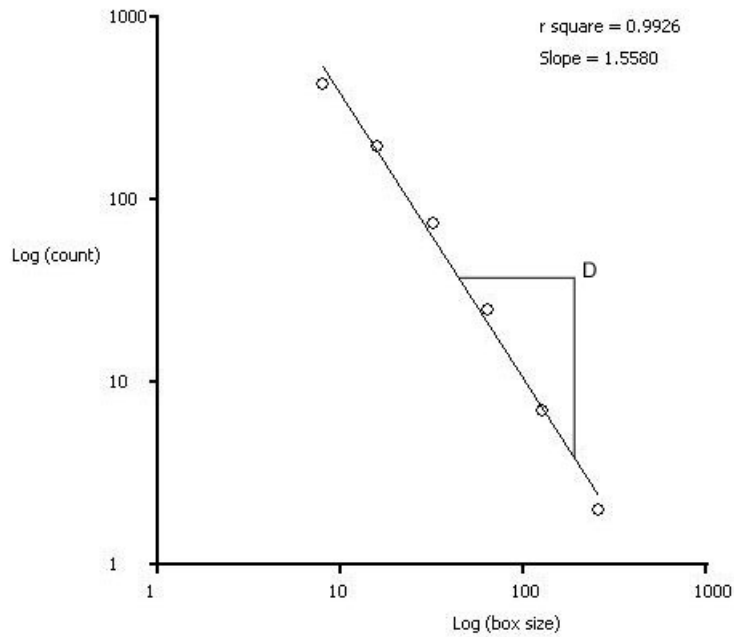

Figure 2.8. The log-log plot of box size versus box number and the estimated fractal dimension (slope, D) generated in Paratrack.

A 3D track can be analysed from the 3D track analysis window by clicking the “3D analysis” button in the main window (Figure 2.9). The layout of the 3D analysis window is very similar to the 2D analysis window, with a few differences (letters refer to the labels in Figure 2.9):

- a) Analysis file selection.
- b) Fractal analysis. This is the same procedure as the 2D fractal analysis, except a 3D grid of cubes is used instead of a 2D grid of squares and therefore the fractal dimension is calculated in three dimensions.
- c) Data averaging. As the video files for the 3D experiment were recorded at a high resolution and frame rate, the resulting extracted tracks are “noisy” and behaviour parameters such as activity, distance travelled and bout analysis are affected. To remove any noise and smooth the tracks, giving a more accurate

analysis, the data can be time and distance averaged. The appropriate checkboxes for time and distance averaging are checked as necessary and the number of time steps to average is entered. For example, if the frame rate was 5 frames per second, entering 5 as the averaging number would give an output of 1 frame per second. The pixel averaging radius is entered which is the radius from the co-ordinate to be averaged. For example, entering 2 here would round the co-ordinates to the nearest 5th pixel. Clicking the “Calculate averages” button saves the averaged data in a new file with the original file name plus “_averaged” added to the end.

d) Distance and time analysis options are identical to those for 2D analysis.

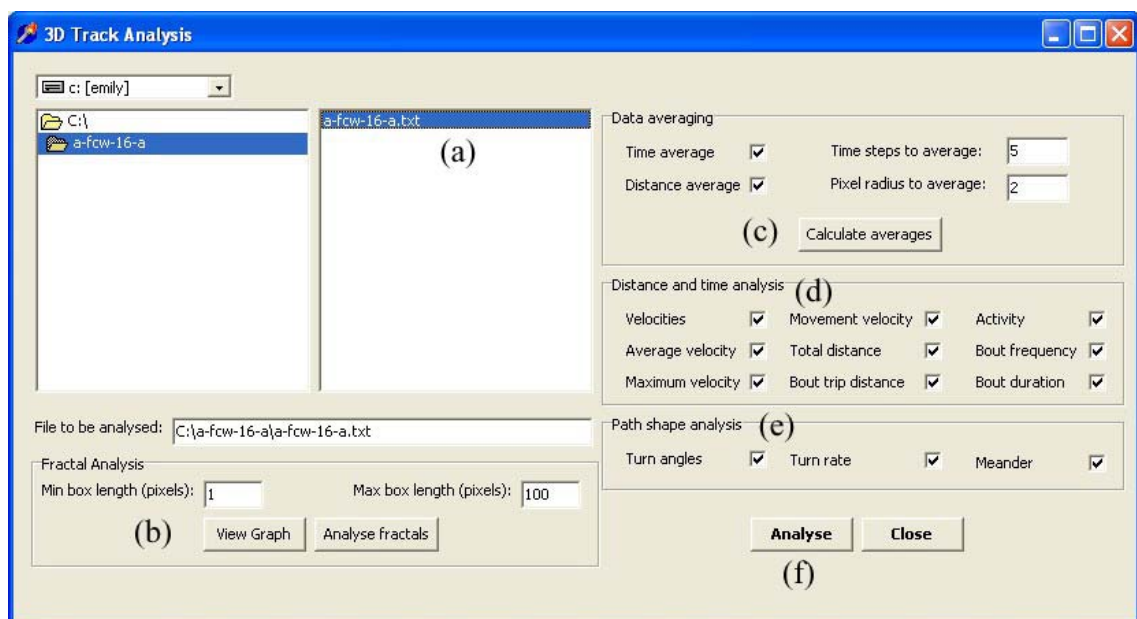

Figure 2.9. The Paratrack 3D track analysis window. (a) File selection box, (b) fractal analysis options, (c) data averaging options, (d) distance and time analysis options, (e) path shape analysis options, (f) start analysis button.

- e) Path shape analysis options are the same as those for 2D analysis except headings are not calculated as this is not possible in 3D and there is no directional cue for the parasites in the 3D experiments (see Chapter 5).
- f) Once all the appropriate check boxes have been checked the “Analyse” button is clicked and all the behavioural parameters are calculated. The resulting output is saved in a new file with the original file name with “_analysed” added to the end. If time averaged data is used then the frame rate must be changed in the main window to that of the averaged data

Once the behavioural information has been calculated the data can be imported into a spreadsheet or statistical software for further analysis.

7. Microscopy

L. branchilis specimens for light microscopy taxonomy were prepared by clearing individuals in lactic acid (Sigma L1250) for 30 minutes, which also softened the connecting tissues, and then dissecting them on a cavity slide using fine mounted needles under a dissecting microscope. Individual appendages from each specimen were mounted in 100% glycerol (Sigma G7757) on a glass slide in order, beginning at the anterior of the specimen and working towards the posterior, and then sealed with clear nail varnish once a coverslip had been placed over them. Whole and dissected specimens were viewed on an Olympus BX51 compound microscope and digital photos were taken using MRGrab 1.0.0.4 (Carl Zeiss Vision GmbH, 2001) software, these being used to prepare drawings.

Specimens for confocal microscopy were prepared by fixing them in 2.5% glutaraldehyde for 1-2 hours, and then rinsing them in distilled water. They were then soaked in either Blankophor (several drops in a watch glass filled with distilled water)

(ICN Biomdeicals Inc. USA) for 30 minutes or Gomori's solution (Gomori, 1950) overnight before rinsing again with distilled water. Individual specimens were then placed into a 35mm glass base dish (Iwaki) and covered with distilled water before being imaged on a Leica TCS SP2 AOBS Confocal Scanning Laser Microscope (CSLM) combined with Leica Confocal Software v6.21.

Chapter 3 – Description of the juvenile free-swimming stages

1. Introduction

The taxonomic descriptions of *Lernaeocera branchialis* span almost a century, from the earliest description by Scott (1901) to more recent descriptions such as Boxshall (1992). However, the most recent detailed full description of the juvenile stages was made by Sproston (1942). Most other descriptions have concentrated on either the pre-metamorphosed or metamorphosed adult female (Schuermans Stekhoven, 1936; Capart, 1948; Kabata, 1979). Other species within the genus *Lernaeocera* were proposed and described (Wilson, 1917; Schuurmans Stekhoven, 1936; Kabata, 1957; Kabata, 1958), but these were later dismissed as different biological forms of *L. branchialis* (Kabata, 1961; Kabata, 1979; Van Damme and Ollevier, 1995). The mouthparts of *L. branchialis* have been studied extensively, but due to disagreement between Scott (1901), Capart (1948) and Sproston (1942), Kabata (1962) attempted a re-examination of the mouthparts, which were finally described successfully by Kabata (1979) and more recently by Boxshall (1990).

The survival and timings of the juvenile stages of *L. branchialis* were studied by Whitfield *et al.* (1988), although there is some disagreement with the observations made by Sproston (1942). Sproston found only one nauplius stage, although two nauplius stages were described by Wilson (1917) and also by Capart (1948), the second stage being described as a meta-nauplius, which would require this stage to have three functional appendages (Huys and Boxshall, 1991). Whitfield *et al.* (1988) mention two nauplius stages but do not provide detailed descriptions or drawings of the stages. The moults from nauplius I to nauplius II, and nauplius II to copepodid are both said to

occur 24 hours after the previous moult (Whitfield *et al.*, 1988), whereas Capart (1948) notes that copepodids are present within 24 hours of hatching.

Taxonomic nomenclature and systematics has developed and changed considerably since Sproston's description of the juvenile stages in 1942 and technological advancements in microscopy have made it possible to study specimens in greater detail. Therefore a re-examination of the free-swimming juvenile stages and stage timings is attempted in this chapter, using a combination of both light and confocal microscopy.

Taxonomic descriptions are traditionally made using light microscopy along with other techniques such as SEM and TEM. Making taxonomic drawings from specimens using light microscopy is a long and laborious process, involving either drawing specimens from many different images at different focus depths or using a *camera lucida*. Confocal microscopy is a new technology that allows whole specimens to be imaged in focus by generating composites of image 'stacks'. Here the possibility of using a single confocal composite image to quickly generate a taxonomic drawing is investigated.

2. Methods

Juvenile stages of *L. branchialis* were collected according to the methods described in Chapter 2. Hatching experiments were conducted by placing an egg-string that was beginning to hatch into a 3cm Petri dish containing full strength seawater (35‰) at 10°C and observing the egg-string under a dissecting microscope (Olympus SZ40) at x4 magnification. As individual nauplii emerged from the eggs, they were removed using a pipette and placed into individual 3cm Petri dishes. The nauplius I stages were observed every few minutes until the moult to nauplius II, after which they were checked every few hours. Between each observation period, the nauplii were kept in a Binder

environmental chamber in darkness at 10°C. Each moult was confirmed by the presence of an exuvia in the Petri dish.

Specimens for light and confocal microscopy were prepared according to the methods described in Chapter 2. Specimen outlines were generated from confocal composite images in Adobe Photoshop CS v.8.0 using the trace contour filter.

3. Results

3.1. Hatching experiments

The results of the hatching experiment show that all nauplius I stages (n=10) moulted to a nauplius II within 59 minutes (except for one that failed to moult and died) (Table 3.1). The earliest moult to nauplius II was recorded at 22 minutes. It can be assumed, therefore, that nauplius I moults to nauplius II around 20 – 50 minutes after hatching at 10°C. The moult to the copepodid occurred between 27 and 46 hours after hatching.

Table 3.1. Moult times for a batch of 10 *L. branchialis* nauplii. ■ = nauplius I, ■ = nauplius II, ■ = copepodid, □ = dead.

Nauplius No.	Time after hatching							
	Minutes				Hours			
1	30	60	85	3.58	23.67	25.42	26.42	46.58
2	30	59	84	3.58	23.67	25.42	26.42	46.58
3	27	58	83	3.53	23.62	25.37	26.37	46.53
4	22	57	82	3.45	23.53	25.28	26.28	46.45
5	21	56	81	3.43	23.52	25.27	26.27	46.43
6	18	55	80	3.38	23.47	25.22	26.22	46.38
7	17	54	79	3.37	23.45	25.20	26.20	46.37
8	17	53	78	3.37	23.45	25.20	26.20	46.37
9	5	52	77	3.17	23.25	25.00	26.00	46.17
10	4	51	76	3.15	23.23	24.98	25.98	46.15

3.2. Nauplius I

The general body shape of the nauplius I is ovoid and carries three pairs of appendages (Figure 3.1). The mean length of the nauplius I was $422 \pm 20 \mu\text{m}$ and the mean width was $212 \pm 14 \mu\text{m}$ ($n=11$). Between the antennules and dorso-anterior to the spherical eye lenses, is found a small papilla along the median line (Figure 3.1-5). This may be the precursor to the rostral gland which secretes the frontal filament in later stages. Along the lateral margins of the posterior end are two slim balancers which are held at right angles to the body (Figure 3.1-6). Distinct regions of dark red pigmentation consisting of globular deposits occur around the middle region of the body and the posterior; a black pigmentation is seen between the eye lenses (Figure 3.2a).

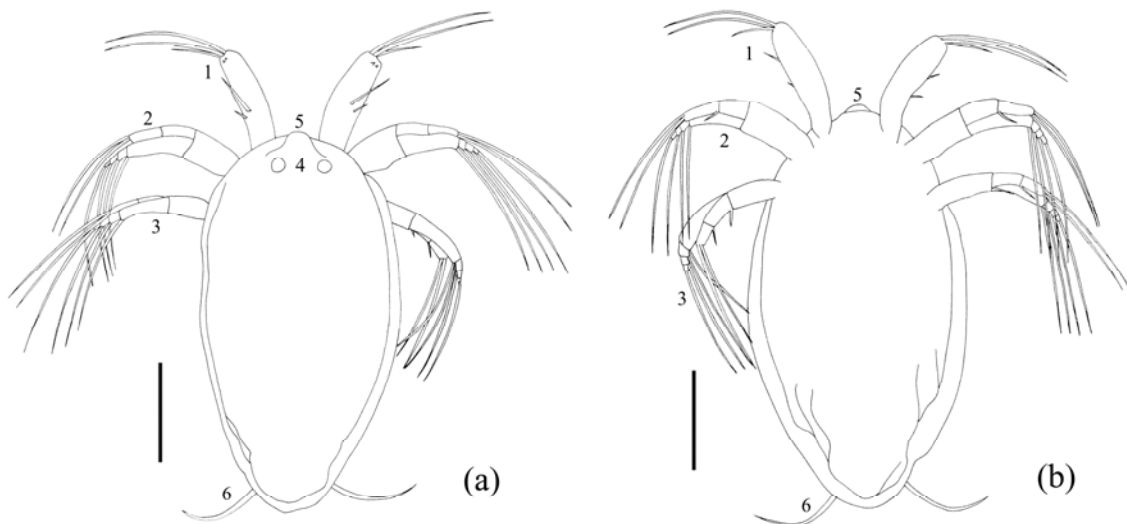

Figure 3.1. *L. branchialis* nauplius I. (a) dorsal aspect (scale bar 0.1mm) and (b) ventral aspect (scale bar 0.1mm). Labels: 1, antennule; 2, antenna; 3, mandible; 4, eye lenses; 5, median papilla; 6, balancer.

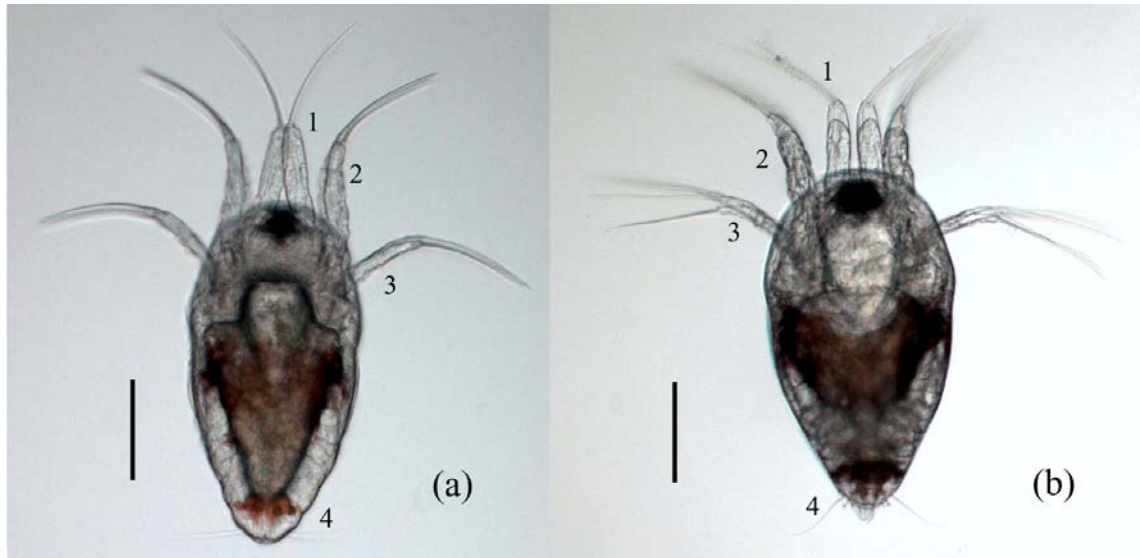

Figure 3.2. *L. branchialis* (a) nauplius I – dorsal aspect (scale bar 0.1mm) and (b) nauplius II – dorsal aspect (scale bar 0.1mm). Labels: 1, antennule; 2, antenna; 3, mandible; 4, balancers.

The sub-cylindrical, uniramous antennules arise ventrally from the frontal region and are unjointed (Figure 3.1-1). Two unarmed setules are found dorsally midway along the endopod (Figure 3.3a1), the distal one (Figure 3.3a2) being longer than the proximal one (Figure 3.3a3). At the terminal tip are found two long plumose setae (Figure 3.3a4) and one unarmed setule (Figure 3.3a5). Two spines occur dorsally in the sub-terminal region (Figure 3.3a6). The biramous antennae (Figure 3.1-2) arise ventrally along the anterior lateral margins and consist of a sympod (Figure 3.3b7) with a four jointed exopodite (Figure 3.3b8) and a two jointed endopodite (Figure 3.3b9); the exopodite being more slender than the endopodite. The proximal ramus of the exopodite is longer than the other three rami combined and the terminal tip of each ramus bears a long plumose seta (Figure 3.3b10). At the base of the distal ramus, on the inner margin of the endopodite is situated an unarmed setule (Figure 3.3b11) and at the terminal tip are two long plumose setae (Figure 3.3b12).

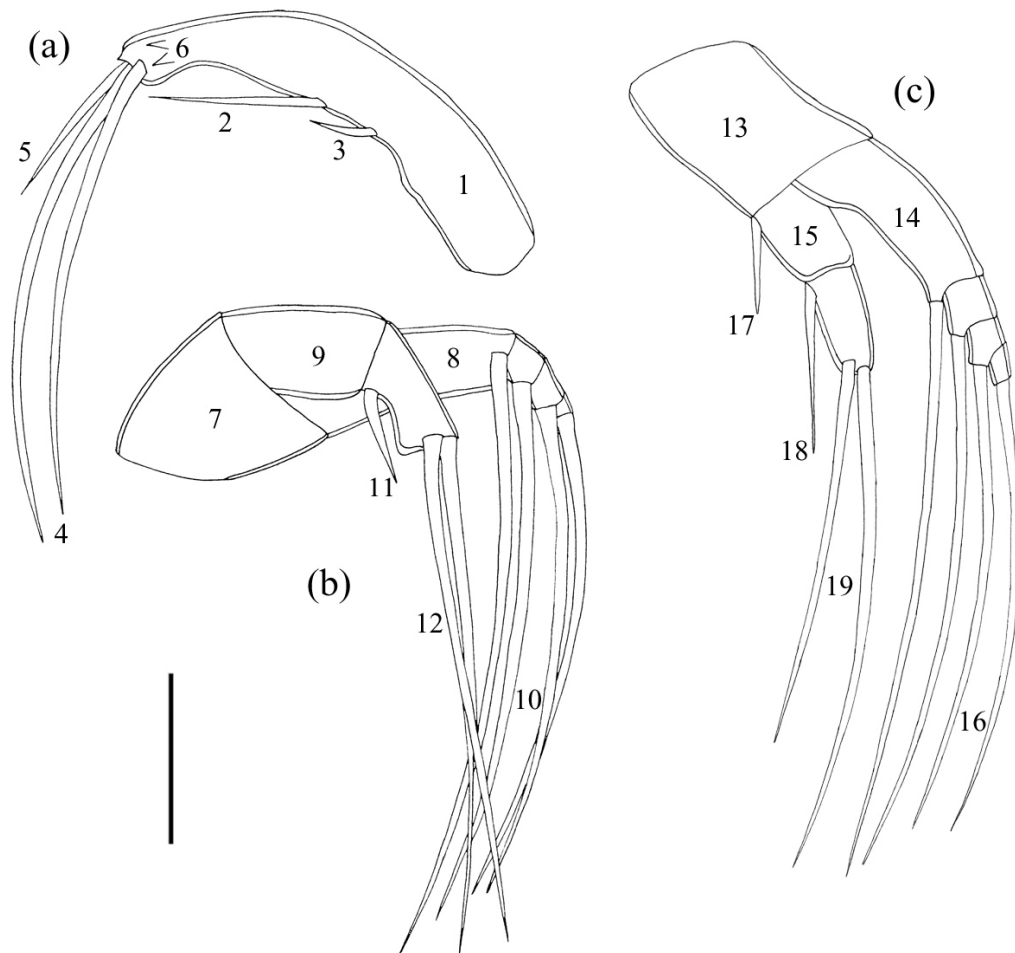

Figure 3.3. *L. branchialis* nauplius I appendages – (a) antennule, (b) antenna and (c) mandible (scale bar 50 μ m). Labels: 1, endopod; 2, distal median setule (unarmed); 3, proximal median setule (unarmed); 4, plumose setae (hairs omitted); 5, terminal setule (unarmed); 6, sub-terminal spines; 7, sympod; 8, exopodite; 9, endopodite; 10, plumose setae (hairs omitted); 11, setule (unarmed); 12, plumose setae (hairs omitted); 13, sympod; 14, exopodite; 15, endopodite; 16, plumose setae (hairs omitted); 17, proximal setule (unarmed); 18, distal setule (unarmed); 19, plumose setae (hairs omitted).

The mandibles (Figure 3.1-3) arise ventrally and posterior to the antennae. The segmentation is identical to the antennae, although they are slimmer. As in the antenna each ramus of the exopodite (Figure 3.3c14) bears a long plumose seta at its tip (Figure 3.3c16). At the base of both rami of the endopodite (Figure 3.3c15), an

unarmed setule (Figure 3.3c17,18) is found on the inner margin and two long plumose setae (Figure 3.3c19) are found at the terminal tip of the distal ramus.

3.3. Nauplius II

The body shape of the nauplius II is slimmer than that of the nauplius I and the frontal region is more flattened (Figure 3.4). The mean length of nauplius II was $390 \pm 18 \mu\text{m}$ and the mean width was $181 \pm 11 \mu\text{m}$ ($n=4$). The body pigmentation in the nauplius II occurs around the middle and posterior regions of the body although it is more extensive and darker than in the nauplius I (Figure 3.2b). The precursor of the rostral gland, which produces the frontal filament, is better developed in the nauplius II (Figure 3.4-5). The appendages are almost identical to those of the nauplius I, except for the spines found on the antennules (Figure 3.5a). The antennule (Figure 3.4-1) carries an unarmed setule (Figure 3.5a2) around midway along the endopod

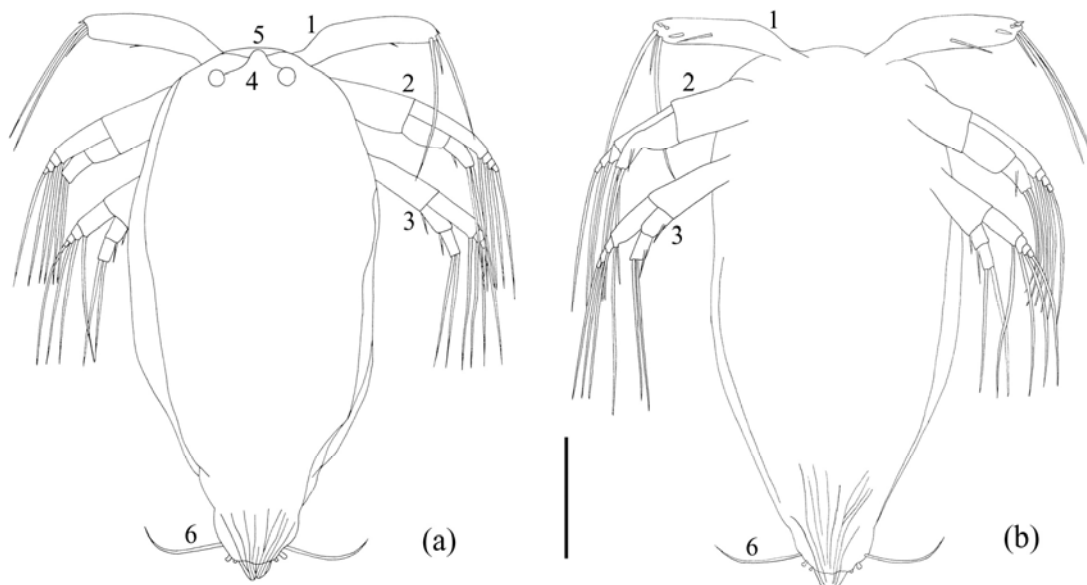

Figure 3.4. *L. branchialis* nauplius II. (a) dorsal aspect and (b) ventral aspect (scale bare 0.1mm). Labels: 1, antennule; 2, antenna; 3, mandible; 4, eye lenses; 5, median papilla; 6, balancer.

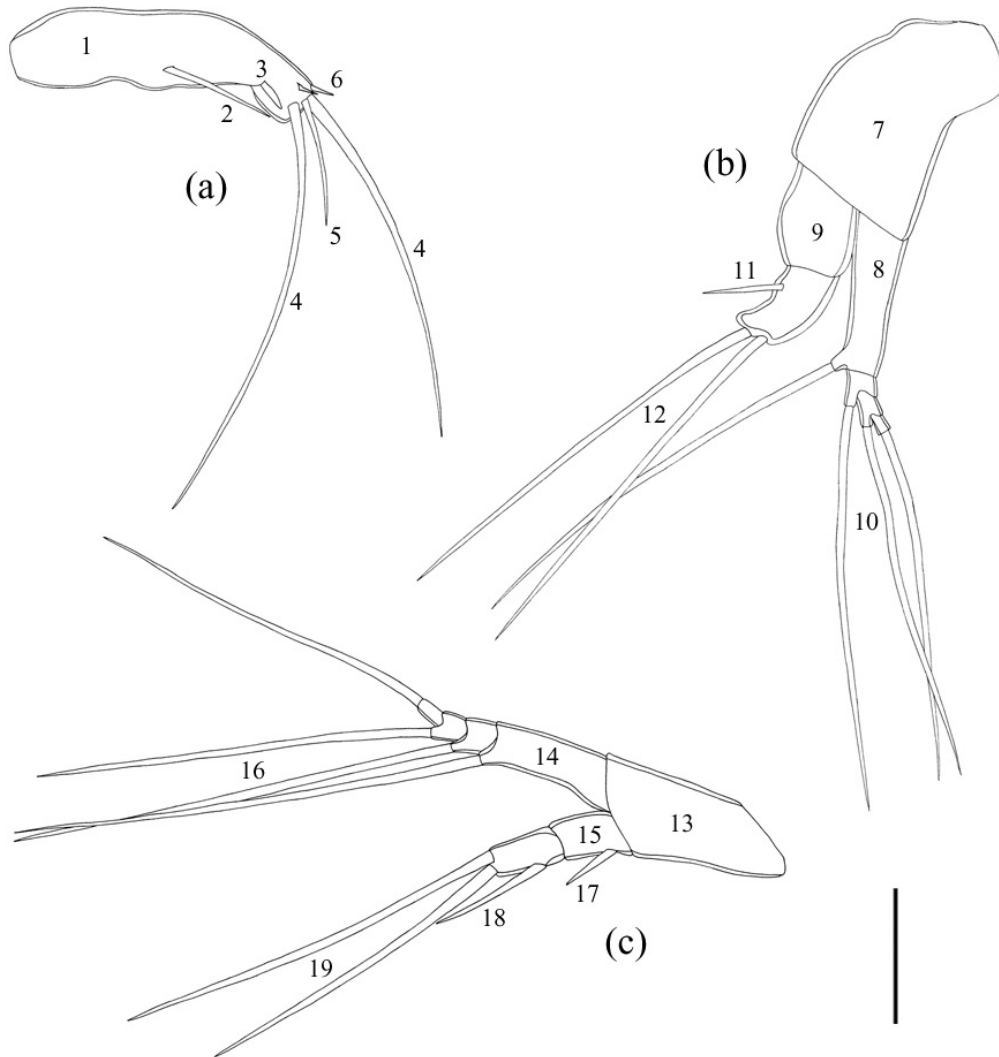

Figure 3.5. *L. branchialis* nauplius II appendages – (a) antennule, (b) antenna and (c) mandible (scale bar 50µm). Labels: 1, endopod; 2, proximal median setule (unarmed); 3, sub-terminal spine; 4, plumose setae (hairs omitted); 5, terminal setule (unarmed); 6, sub-terminal spines; 7, sympod; 8, exopodite; 9, endopodite; 10, plumose setae (hairs omitted); 11, setule (unarmed); 12, plumose setae (hairs omitted); 13, sympod; 14, exopodite; 15, endopodite; 16, plumose setae (hairs omitted); 17, proximal setule (unarmed); 18, distal setule (unarmed); 19, plumose setae (hairs omitted).

(Figure 3.5a1) and a thick spine (Figure 3.5a3) sub-terminal to the tip. The two short spines (Figure 3.5a6) and one unarmed setule (Figure 3.5a5) between the two plumose setae (Figure 3.5a4) are identical to those found in the nauplius I. Along the lateral margins of the terminal region of the body are found two balancers (Figure

3.6-1) as in the nauplius I, but also four small protrusions (Figure 3.6-2), which may be sensory organs, two to either side of a posterior process (Figure 3.6-3). The posterior process appears to be paired and is likely to be the developing caudal rami (Boxshall *pers. comm.*). Through the cuticle of the nauplius II, the developing setae of the copepodid are visible in older specimens and these extend into the posterior process.

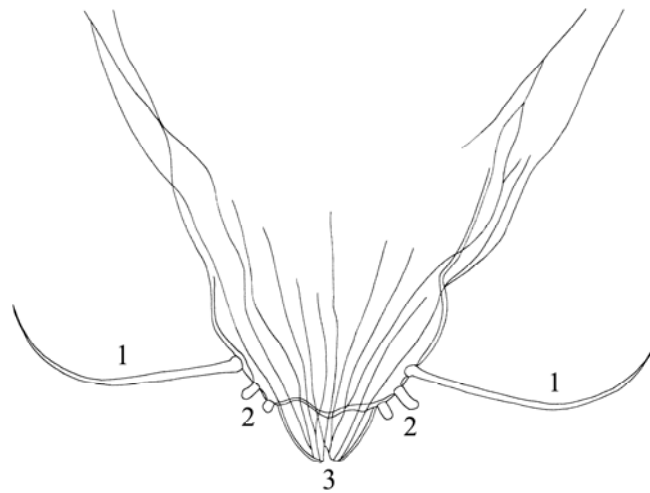

Figure 3.6. *L. branchialis* nauplius II terminal tip (scale bar 50 μ m). Labels: 1, balancer; 2, protrusions; 3, posterior process.

3.4. Copepodid

The cephalothorax of the copepodid is about five eighths of the body length and shows a strong ventral infolding along the lateral margins (Figure 3.7). The mean length of the copepodid was $540 \pm 19\mu\text{m}$ and the mean width was $195 \pm 17\mu\text{m}$ ($n=10$). The body displays black pigmentation with the darkest pigmentation around the eye lenses (Figure 3.8). Pigmentation in the thoracic segments is dark red to black.

Copepodid specimens were observed both free-swimming and attached to a gill tip by a frontal filament. In specimens attached to a gill tip, the frontal filament consists

of a conical strand arising from the ventral face of the rostral gland and embeds into the host's tissue before becoming bifurcated. Each branch terminates in a large, spherical swelling. Apart from the frontal filament, the free-swimming and attached copepodids are identical, suggesting that the moult takes place after the copepodid is secured to the gill tip of the host and that there is only one copepodid stage.

The antennules arise ventrally from the front of the copepodid and are indistinctly four-segmented (Figure 3.7-1), with a constriction near the terminal end (Figure 3.9a1) indicating the segmental boundary of a fifth segment. The second and third rami each bear one seta (Figure 3.9a2,3). The terminal ramus bears one seta proximal to the constriction (Figure 3.9a4) and 13 setae (Figure 3.9a5) plus one long, stout

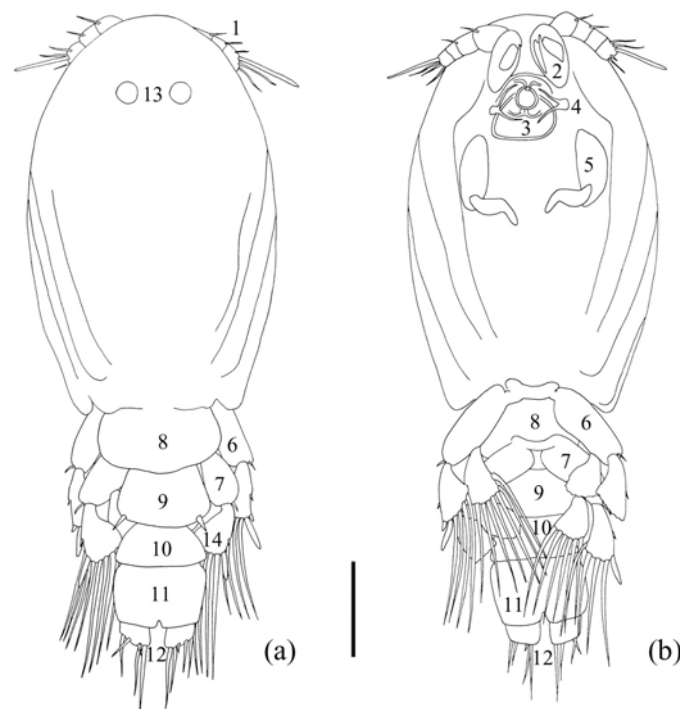

Figure 3.7. *L. branchialis* copepodid. (a) Dorsal aspect, (b) ventral aspect (right swimming leg 1 and left swimming leg 2 are drawn without setae for clarity) (scale bar 0.1mm). Labels: 1 antennule; 2, antenna; 3, buccal tube; 4, maxillule; 5, maxilla; 6, first swimming leg; 7, second swimming leg; 8, second thoracic somite; 9, third thoracic somite; 10, fourth thoracic somite; 11, fifth thoracic somite; 12, caudal rami; 13, eye lenses; 14, spine.

aesthetasc (Figure 3.9a6) at the terminal tip. All the setae are unarmed.

The antennae are found ventrally and posterior to the antennules (Figure 3.7b2). They consist of two broad, heavily chitinised, short segments (Figure 3.9c7,8) and the terminal ramus is chelated, with a stout hook fitting into a shallow groove at the tip (Figure 3.9c10). These are used to anchor the copepodid to the gill tip of the intermediate host and prevent it from being dislodged by the strong currents in the gill chamber. On the distal border of the terminal segment is found a small blunt process (Figure 3.9c9).

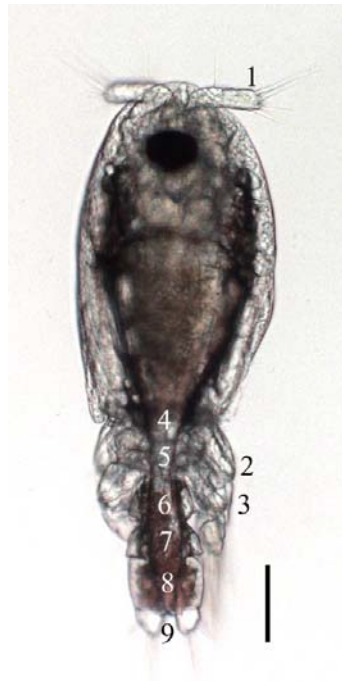

Figure 3.8. *L. branchialis* copepodid (scale bar 0.1mm) 1, antennule; 2, first swimming leg; 3, second swimming leg; 4, first thoracic somite; 5, second thoracic somite; 6, third thoracic somite; 7, fourth thoracic somite; 8, fifth thoracic somite; 9, caudal rami.

The buccal tube is posterior to the antennae and is located on the ventro-medial line (Figure 3.7b3). The labrum and labium have not yet fused at this stage and each contributes an equal portion to the buccal tube. Inside the buccal tube two buccal

stylets project downwards. The uniramous mandibles arise laterally to the buccal tube and are long, slender appendages with sharp terminal points devoid of teeth. In this stage they are not yet inserted into the buccal tube. Found laterally to the mandibles, the maxillules are bilobed with the inner lobe bearing two setae and the outer lobe bearing a single seta (Figure 3.7b4). The maxillae are found ventrally and posterior to the mouth tube (Figure 3.7b5). They consist of two segments; a long broad basal ramus (Figure 3.9b11) and a narrower terminal ramus (Figure 3.9b12), which is hooked and blade-like at the terminal tip.

Two pairs of biramous swimming legs are present, the first (Figure 3.7-6) attached to the first thoracic somite, which is fused to the cephalothorax and the second (Figure 3.7-7) attached to the second thoracic somite (Figure 3.7-8). Both pairs of legs are connected by an intercoxal sclerite, which ensures each pair of legs beat simultaneously. The first swimming leg consists of a broad, flat protopod (Figure 3.9d13,14), and an exopodite (Figure 3.9d15) and an endopodite (Figure 3.9d16) each consisting of a single ramus. A short plumose setule is found at the lateral margin of the basis (Figure 3.9d17). The exopodite (Figure 3.9d15) arises from the basis (Figure 3.9d14) close to the lateral margin of the joint between the coxa (Figure 3.9d13) and basis. Along the distal margin it bears four long, plumose setae (Figure 3.9d18) plus a papilliform outgrowth (Figure 3.9d19) and a short, blunt spine (Figure 3.9d20) on the dorsolateral margin. A single spine (Figure 3.9d21) is found half way along the anterior edge. The outermost seta narrows around one quarter length from its base and carries a fringe of short hairs on one edge (Figure 3.9e22). The endopodite (Figure 3.9d16) bears seven long, plumose setae (Figure 3.9d23) along its distal margin. The second swimming leg is very similar to the first, except the

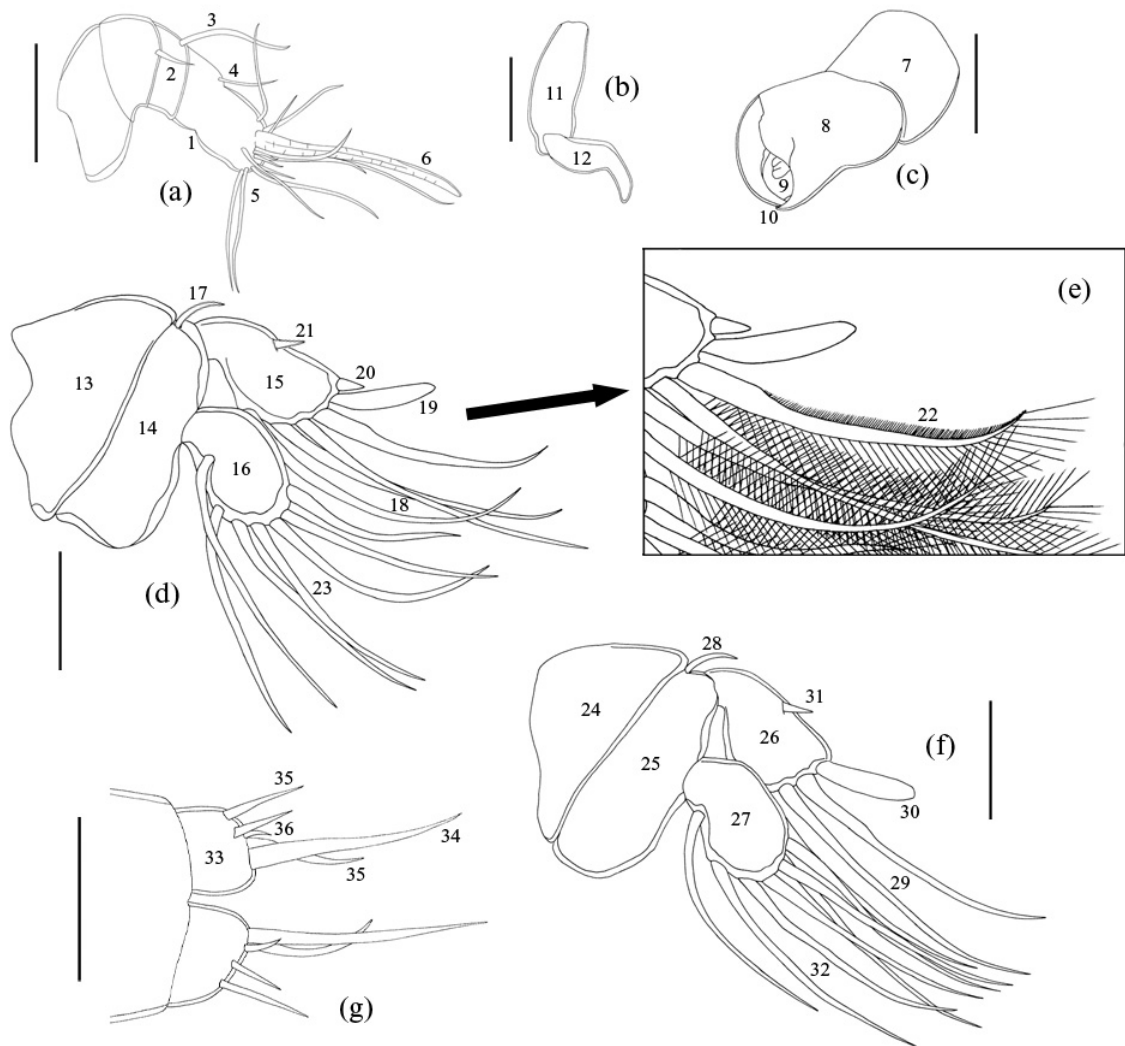

Figure 3.9. *L. branchialis* copepodid appendages (scale bars 25 μ m). (a) antennule, (b) maxilla, (c) antenna, (d) 1st swimming leg, (e) portion of 1st swimming leg showing fine hairs, (f) 2nd swimming leg and (g) caudal rami. Labels: 1, sub-terminal constriction; 2, seta (unarmed); 3, seta (unarmed); 4, seta (unarmed); 5, setae (unarmed); 6, aesthetasc; 7, basal ramus; 8, chelated terminal ramus; 9, blunt process; 10, hook and groove; 11, basal ramus; 12, terminal ramus; 13, coxa; 14, basis; 15, exopodite; 16, endopodite; 17, plumose setule (hairs omitted); 18, plumose setae (hairs omitted); 19, papilliform outgrowth; 20, blunt spine; 21, spine; 22, fringe of short hairs; 23, plumose setae (hairs omitted); 24, coxa; 25, basis; 26, exopodite; 27, endopodite; 28, plumose setule (hairs omitted); 29, plumose setae (hairs omitted); 30, papilliform outgrowth; 31, spine; 32, plumose setae (hairs omitted); 33, caudal ramus; 34, long plumose seta (hairs omitted); 35, short plumose seta (hairs omitted); 36, setules (unarmed).

exopodite (Figure 3.9f26) does not have a spine on the dorsolateral margin, and the endopodite (Figure 3.9f27) bears only six setae (Figure 3.9f32).

Five thoracic somites are present, although the first can not be distinguished as it is fused to the cephalothorax. The second somite (Figure 3.7-8) is also fused to the cephalothorax but is clearly visible as a separate segment. The third somite (Figure 3.7-9) has a trapezoidal shape and carries two short spines on the posterior lateral corner (Figure 3.7a14), which are the rudiments of the third pair of swimming legs found in later stages. The fourth somite (Figure 3.7-10) has a trapezoidal shape and represents the pre-genital and genital segments found in later stages. The fifth somite (Figure 3.7-11) has a long rectangular shape and bears two large caudal rami at its terminal tip (Figure 3.7-12; Figure 3.9g33). Each caudal ramus carries three plumose setae, one long (Figure 3.9g34) and two short (Figure 3.9g35), and two short setules (Figure 3.9g36).

3.5. Confocal microscopy

Confocal microscopy involved a simple and quick procedure to generate images appropriate for creating taxonomic drawings, compared to procedures involved for generating appropriate images using light microscopy. Once specimens had been stained a set of images for a single specimen could be generated in under an hour. After composite images had been created from the confocal image stacks, methods of producing taxonomic drawings in Adobe Photoshop were investigated and they were eventually produced according to the following procedure:

1. An outline of the specimen is created using the trace contour filter and adjusting the level to pick up the specimen outline (Figure 3.10b).

2. The outline is overlaid onto the original image (Figure 3.10c).
3. Segmental boundaries and other features such as spines that are not contrasted against the background are drawn manually, using the original image as a guide (Figure 3.10d).
4. The outline image is desaturated and contrast increased to make the outline appear black (Figure 3.10e).
5. A blur filter is applied to soften the edges of the lines (Figure 3.10f).

As can be seen from Figure 3.10f, an initial taxonomic drawing can be automatically generated from a confocal composite image with the whole process taking around 30 minutes or less. However, the short spine halfway along the antennule of the nauplius I and the two short spines at the post-terminal tip were not drawn as they were not visible on the confocal image.

By enlarging an area of the specimen it is possible to see the fine detail that may not be visible in whole specimen images. In Figure 3.11, all of the segmentation and spines of the nauplius II antenna and mandible have been identified and drawn automatically.

Using this technique it is also possible to draw fine detail such as individual hairs on setae. In Figure 3.12 the fine hairs on the mandible of nauplius II have been picked out by the trace contour filter, enabling the number of hairs on the setae to be counted. Counting fine hairs from light microscopy images would be a long, painstaking process and prone to error. However, care must be taken when interpreting this kind of image as hairs are only visible on one side of each seta and whilst for some setae there are no hairs, but in the mandible they are known to occur on both sides of all setae. Good staining and imaging are important to ensure that all the hairs are visible on the image for this type of quantitative work.

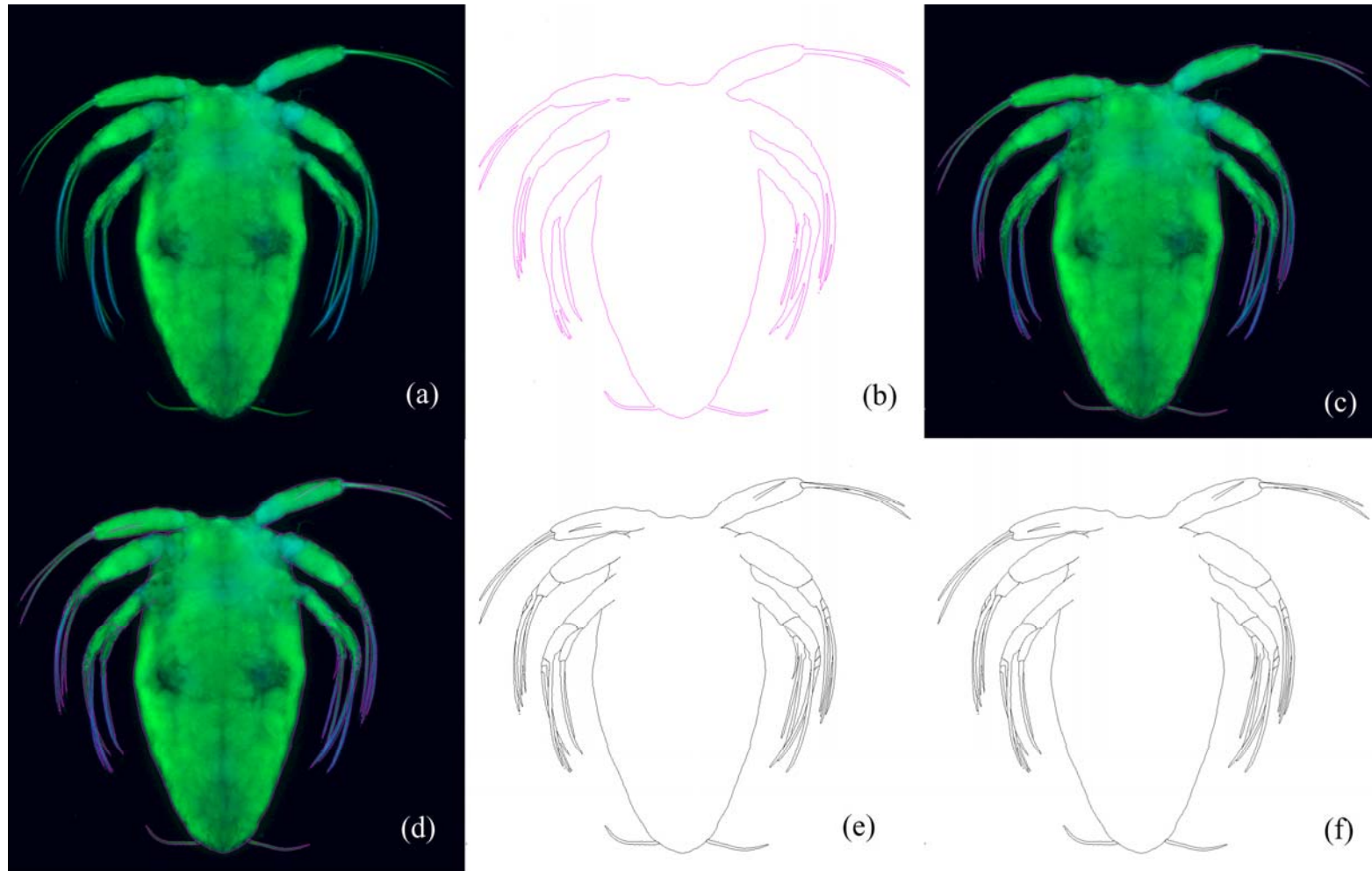

Figure 3.10. Generation of a specimen drawing from a confocal image. (a) Nauplius I confocal image fixed in 2.5% glutaraldehyde and stained with Blankophor, (b) Extracted outline, (c) outline overlaid on original image, (d) segmental boundaries added to outline, (e) image desaturated and (f) blur filter to soften edges.

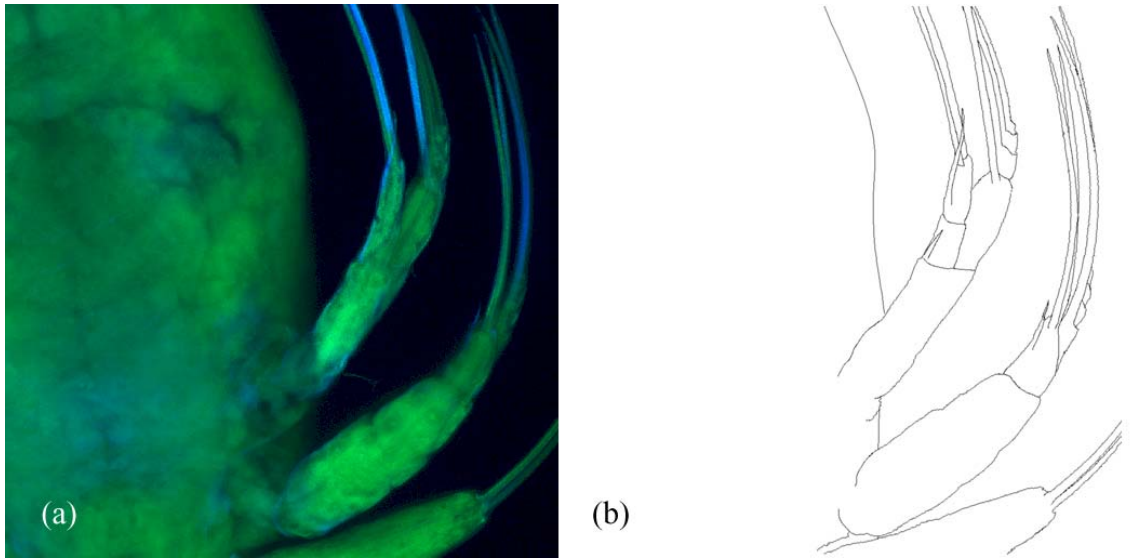

Figure 3.11. Nauplius II antenna and mandible fixed in 2.5% glutaraldehyde and stained with Blankophor. (a) original confocal image, (b) extracted taxonomic drawing.

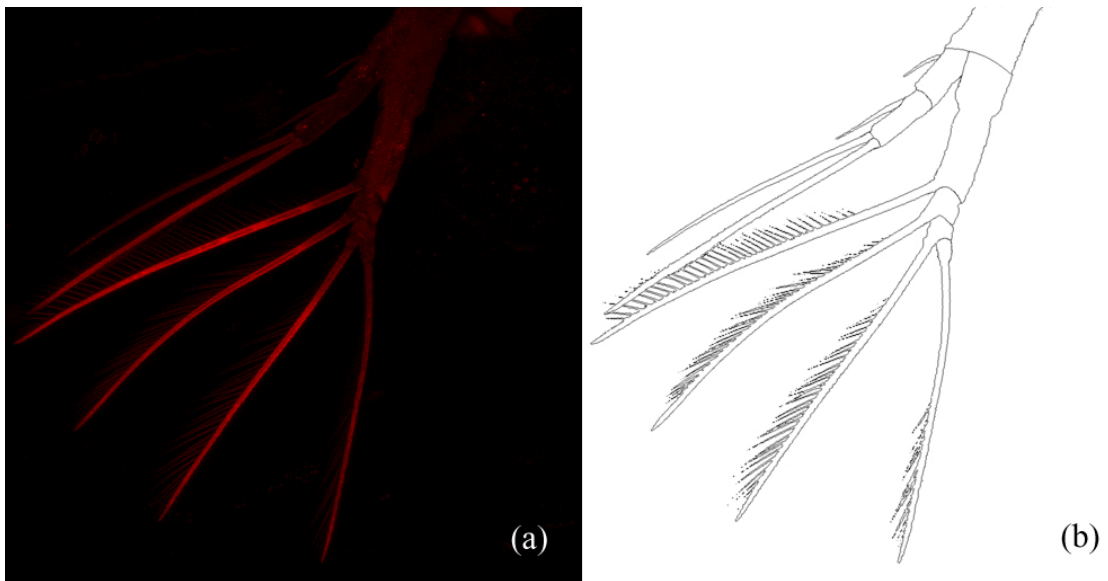

Figure 3.12. Nauplius II mandible fixed in 2.5% glutaraldehyde and stained with Gomori's solution. (a) Original confocal image, (b) extracted taxonomic drawing.

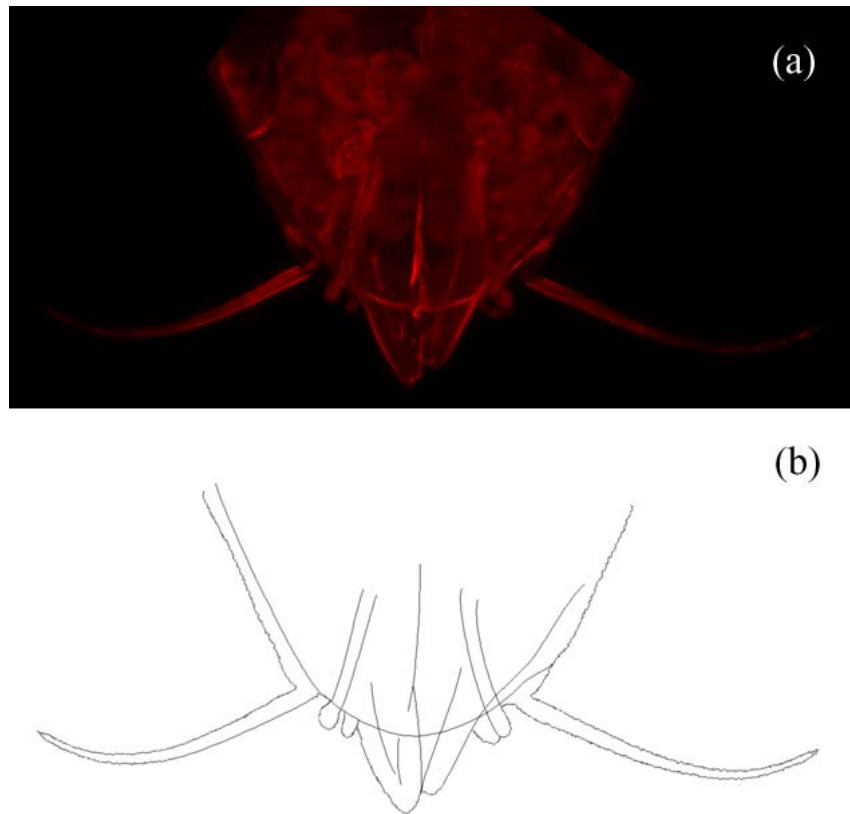

Figure 3.13. Nauplius II posterior fixed in 2.5% gluteraldehyde and stained with Gomori's solution. (a) original confocal image, (b) extracted taxonomic drawing.

Confocal microscopy can define features that would not be visible using light microscopy, due to varying fluorescence of different structures. In Figure 3.13 the small protrusions either side of the posterior process in nauplius II are clearly visible as channels which enter the body of the nauplius.

Figure 3.14 shows one of the problems inherent with this technique. As the swimming legs of the copepodid are overlaid a mass of setae occurs, which cannot be accurately delineated by the trace contour filter and the subsequent outline image is untidy and inaccurate. However, this may be overcome by dissecting the specimen and imaging the appendages individually using the confocal microscope.

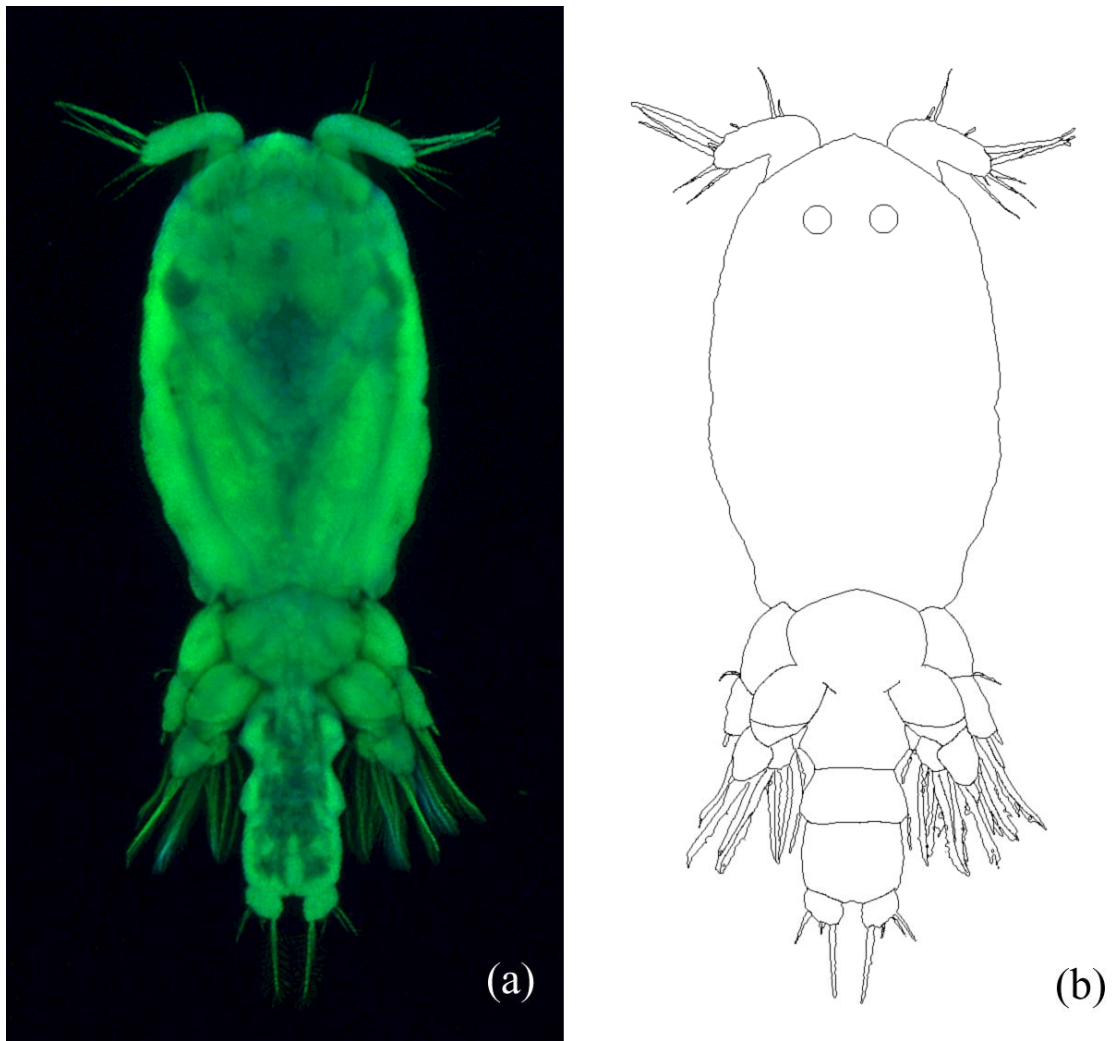

Figure 3.14. Copepodid fixed in 2.5% glutaraldehyde and stained with Blankophor. (a) original confocal image, (b) extracted taxonomic drawing highlighting a problem when complex images are processed. Here the setae of the swimming legs create an untidy image.

4. Discussion

4.1. Egg hatching and moult timings

According to previous reports the moult from nauplius I to nauplius II is said to occur 24 hours after hatching at 10°C (Whitfield *et al.*, 1988). The results of this study, however, where the nauplii were continually observed, have shown that this

moult occurs around 20-50 minutes after hatching at 10°C. The moult from nauplius II to copepodid occurred 27-46 hours after hatching in this experiment. This agrees with both the results of Capart (1948) and Whitfield *et al.*, (1988), as Capart reported that copepodids are present 24 hours after hatching, which is close to the shortest time recorded here for the moult to copepodid, and Whitfield reported that copepodids are present 48 hours after hatching, which is close to the upper limit in this study. However, it is likely that the moult to the copepodid is not protracted over such a long period and further observation is required, checking the nauplius II stages more often, to determine the actual timing of the moult to the copepodid.

As only one nauplius stage was found by Sproston (1942), it is possible that the nauplius I was overlooked as this stage is very short, and her description of a nauplius appears to correlate with the morphology of the nauplius II.

Using the timings from egg hatching to copepodid in this study, *L. branchialis* is infective within 1-2 days after hatching. As the planktonic phase of the life-cycle is perilous, these quick moults to the infective copepodid are likely to improve survival rates. This short planktonic period combined with the extended hatching period of 12 days and long maximum survival time of the copepodids of 18 days (Whitfield *et al.*, 1988) means that *L. branchialis* can quickly and continuously infect intermediate hosts leading to a high spatial distribution and a high prevalence and intensity of infection on the intermediate host. In comparison, the times required from hatching to copepodid in other siphonostomatoids are around 90 hours for *Caligus elongatus* (Piasecki and MacKinnon, 1995) and 4-6 days for *Lernaeenicus sprattae* Sowerby, 1806 (Schram, 1979).

4.2. Comparisons with other siphonostomatoids

In many aspects the free swimming juvenile stages of *Lernaeocera branchialis* are very similar to those reported for other siphonostomatoids. In the pennellid *Lernaeenicus sprattae*, which parasitises sprat (*Sprattus sprattus* (L.)), only the number and positioning of spines on the antennules anatomically distinguishes the nauplii from those of *L. branchialis*. In *L. sprattae*, the antennule of the nauplius II bears four spines at its apical tip and two in the middle of the appendage (Schram, 1979), whereas in *L. branchialis* only three spines are found at the tip, plus one sub-terminal spine and one in the middle of the appendage. The segmentation and armature of the antennae and mandibles are identical for *L. sprattae* and *L. branchialis*. Differences in colouration are present, with *L. sprattae* having a blueish-back pigment (Schram, 1979) and *L. branchialis* a red-black pigment.

The nauplii of the caligids *Caligus elongatus* and *Lepeophtheirus salmonis* are also very similar to those of *L. branchialis*, although the overall body shapes are different with the caligids being more elongate (Johnson and Albright, 1991; Piasecki, 1996). The main distinction between the appendages of *C. elongatus*, *L. salmonis* and *L. branchialis* is the segmentation of the antennules in the caligids, whereas in *L. branchialis* the antennule is unsegmented.

The average size of the copepodids of *L. branchialis* and other pennellids are largely similar, the average length of *L. branchialis* being 484µm (Sproston, 1942) compared to 450µm in *Cardiodectes* spp. (a pennellid parasitic on fish, which infects snails as its intermediate host) (Ho, 1966), and 480 µm in *Penella varians* Steenstrup and Lütken 1861 (a pennellid parasitic on cephalopods) (Rose and Hamon, 1953). Only copepodids of *L. sprattae* are larger, averaging 628µm (Schram, 1979). The pigmentation varies between different pennellids: *L. branchialis* displays red and

black pigmentation; *L. sprattae* shows black pigmentation (Schram, 1979), and *Cardiodectes* spp. is covered in dark blotches (Ho, 1966).

The armature of the antennule in *L. branchialis* is similar to that of *L. sprattae*, *Cardiodectes* spp., and *Penella varians*, except on the terminal segment *L. sprattae* has one less seta (12), *Cardiodectes* has two fewer setae (11) and *P. varians* has three fewer setae (10) (Schram, 1979; Ho, 1966; Rose and Hamon, 1953), compared to 13 setae in *L. branchialis*. The antenna of *L. branchialis* appears to differ from that of other pennellids that have been described, in that it has a blunt process on the distal border of the terminal segment instead of a spine (Schram, 1979; Rose and Hamon, 1953; Jungersen, 1913). In pennellids, the antenna consists of two segments, whereas in caligids the endopod is fused to form a single segment (Boxshall, 1990).

The relative proportions of the labrum and labium that form the buccal tube in *L. branchialis* differ to those of *Cardiodectes* spp. In *L. branchialis* both the labrum and labium contribute an equal portion of the buccal tube, whereas in *Cardiodectes* spp., the labrum is smaller and only the labium is connected with the marginal membrane (Ho, 1966), which is a feature found in later stages of *L. branchialis*.

The segmentation and armature of the mandible and maxillule are identical for *L. branchialis* and most other pennellids that have been described, the mandible consisting of a single segment with a sharp pointed terminal tip, which represents the coxal gnathobase, and the maxillule being bilobed, both of which are features homologous with caligids (Boxshall, 1990). Only the maxillule of *Cardiodectes* spp. differs, having a small exopod bearing a single seta, which appears to be absent in other pennellids. Similarly, the maxilla of pennellids and caligids are homologous, consisting of two segments representing the coxa and a long drawn out basis. Ho (1966) described the maxilla of *Cardiodectes* spp. as having three segments.

However, this may have been a misidentification, the hooked tip of the terminal segment being described as a separate segment.

The segmentation and armature of the swimming legs of *L. branchialis* copepodids appears to be identical to other pennellids that have been described (Rose and Hamon, 1952; Ho, 1966; Schram, 1979). As in all siphonostomatoids, the first thoracic somite is fully fused with the cephalothorax (Anonymous 1991). The fusion of the pre-genital and genital segments to form a genital complex is homologous with caligids and possibly other siphonostomatoids parasitic on fish (Boxshall, 1990). The thoracic segments of *L. sprattae*, *Cardiodectes* spp. and *L. branchialis* are identical although the caudal rami differ (Ho, 1966; Schram, 1979). In *L. branchialis* each caudal ramus bears three plumose setae and two setules, whereas in *Cardiodectes* spp. and *L. sprattae* each caudal ramus bears four plumose setae and one setule (Ho, 1966; Schram, 1979). In addition, the medial border of the caudal ramus in *Cardiodectes* spp. bears a row of cilia (Ho, 1966), but these are absent in *L. sprattae* and *L. branchialis*.

In all other pennellids that have been described, copepodids have been observed both free-swimming and attached to the host by a frontal filament. In *L. branchialis*, it was previously thought that the frontal filament is extruded during the moult to chalimus I (Sproston, 1942). However, the current observations and those of other workers suggest that the frontal filament in pennellids is extruded before the moult to chalimus I (Rose and Hamon, 1952; Rose and Hamon, 1953; Ho, 1966; Schram, 1979). This was confirmed in *Cardiodectes* spp., where several copepodids attached by their frontal filament were observed moulting to a chalimus I and their exuviae were exact templates of the free-swimming copepodid (Ho, 1966). The frontal filament of pennellids appears to differ from that of caligids in that it is bifurcate

(Ho, 1966; Schram, 1979), whereas in caligids the filament consists of a single strand (Piasecki and MacKinnon, 1993; Pike *et al.*, 1993; Gonzalez-Alanis *et al.*, 2001). Further study is required in *L. branchialis* to confirm the timing of the frontal filament production, and describe its development and ultrastructure.

4.3. Confocal microscopy

The investigation of the potential for using confocal images for producing taxonomic drawings has shown that there are good prospects for this new technique. The main purpose of a taxonomic drawing is to clearly and accurately illustrate anatomical features. By using a contour filter on a confocal image and manually drawing segmental boundaries the anatomical features of the specimen are effectively distilled from the original image. This method has many advantages over traditional methods creating hand drawn images from light microscopy or SEM, the first and foremost being the time and training required to create such images. Making drawings using a *camera lucida* or a series of photographs at different focal depths is a lengthy process and requires a great deal of skill and training to both manipulate the image and correctly recognise and draw the anatomical features of the specimen. In confocal microscopy, only light from a narrow plane is used to generate an image and light from neighbouring planes are rejected, which greatly increases the resolution of the image. By capturing sequential layers through the specimen and combining them using computer software an image is created that is in sharp focus throughout the whole specimen. The fluorescence of the specimen contrasts against the dark background of the image making it easy to delineate the outline using a contour filter. The only real skill and time required is in drawing the segmental boundaries, where knowledge of the anatomy of the species being studied is

necessary. Drawing the segmental boundaries can be greatly simplified by using a pen and graphics tablet instead of a mouse.

As the outline of the specimen is automatically generated there is no risk of error which ensures that the shape and size of the features are accurate. Using light microscopy and changing the focus to view different features can easily distort the image leading to inaccuracies in the drawing. By overlaying the specimen outline onto the original confocal image, the segmental boundaries can also be accurately drawn, using the confocal image as a guide.

The fixing and staining of specimens for creating taxonomic drawings is an important consideration as this determines the fluorescence of the specimen. Although the specimens used here have some autofluorescence, the use of stains or fixatives to enhance the fluorescence of the cuticle greatly improves results. The use of different stains was investigated, including Gomori's solution, phalloidin and resorufin, although for this application the best results were achieved with Blankophor. Both fresh and fixed specimens were used, but it was discovered that fixing in glutaraldehyde caused the cuticle to fluoresce strongly, so specimens fixed in 2.5% glutaraldehyde were used for the final images. In several images in this study some of the smaller features, such as spines and setules are not visible and further experimentation with different staining techniques may improve results. Although these fine features can be distinguished by enlarging a small portion of the specimen, the effectiveness of the technique would be enhanced if all the main anatomical features were visible on a single image of the whole specimen, leaving no room for error caused by using several images to create a single drawing.

An advantage of using different fluorescent stains is that different features can be highlighted which would not be visible using light microscopy or SEM. In this study

using Gomori's solution enabled the small protrusions at the terminal tip of the nauplius II to be visible extending as channels into the body, which may give clues as to the function of these structures. Using phalloidin, which is a muscle stain, the musculature of specimens can be easily and accurately mapped, which may help identify the origin and function of appendages.

A further benefit of this technique over traditional techniques is the automatic generation of outlines of finer features, such as hairs on setae. Although these fine hairs are visible using light microscopy, counting and drawing these hairs is prone to miscalculations. By viewing a single appendage on the confocal microscope, the individual hairs on each seta are visible and can be automatically and accurately drawn using the contour filter.

The only real obstacle with this technique of creating outlines using a contour filter occurs when structures overlay other structures as illustrated in the copepodid in the present data (Figure 3.14). As the swimming legs overlay each other, the setae cannot be separated. Although it would be possible to draw the setae manually, a better solution would be to image individual dissected legs. Another solution would be to take a portion of the confocal image stack containing each swimming leg and contour them separately, before adding the images together, although this would only be possible if the legs and setae were flat and parallel to the orientation of the image stack. Further experimentation with more advanced contour filters may overcome this problem.

There are, however, some limitations to using confocal microscopy for the purpose of creating taxonomic drawings. Large specimens may be too thick to fully image and, therefore, the technique is limited to smaller specimens. Also the features of

interest must either autofluoresce or be stainable to enable them to be visible using confocal microscopy.

By using automated digital techniques to generate taxonomic drawings, the integration of one of the most traditional scientific disciplines into the digital age has begun. Although these are only preliminary results, they demonstrate how taxonomic drawings might be quickly and effectively generated from confocal microscope images. With further investigation of different staining and contouring techniques it should be possible to produce relatively accurate taxonomic drawings with minimum time and effort. Using these digital images it would also be possible to utilise other automated techniques such as size and shape descriptors to further analyse specimens.

One of the biggest hurdles of traditional taxonomy is the sharing and transport of material, especially holotypes and paratypes, which are easily lost or damaged. As with any other digital information, it would be simple and quick to share and disseminate digital taxonomic images using email or other digital media, with no risk of damage or loss to individual specimens. Although these taxonomic drawings could not replace original holotype specimens, the use of confocal data to generate 3D digital animations of specimens could be used as an alternative to holotypes. Using these “e-type” specimens it would be quick and easy to share this important taxonomic information with scientists around the world, allowing the original type specimens to be stored safely. The use of e-types as an alternative to holotypes requires further investigation, but depending on their preservation technique it may be possible to image type specimens using confocal microscopy to create 3D e-types and this is one of the research opportunities using information technologies listed by Gaston and O'Neill (2004) that requires immediate attention in light of the current

biodiversity crisis. As one of the main difficulties in using taxonomic products is access to adequate reference collections (Gaston and O'Neill, 2004), the use of e-types will help to alleviate this problem by making reference collections immediately available to anyone. It may also be possible to integrate e-type technology into automated species identification software packages that are under development (Dietrich and Pooley, 1994; Gauld *et al.*, 2000; Jonker *et al.*, 2000; O'Neill *et al.*, 2000; Arbuckle, 2000; Arbuckle *et al.*, 2001). In light of the decline in taxonomic research in recent years (Gaston and O'Neill, 2004; Wheeler, 2004a,b), this semi-automation and digitisation of taxonomic descriptions is an important step in improving this important scientific discipline and bringing morphology-based taxonomy into the 21st century.

Chapter 4 – Parasite behaviour and host location in *Lernaeocera branchialis* : Choice chamber experiments

1. Introduction

Although the life-cycle of *Lernaeocera branchialis* has been well documented (Scott, 1901; Sproston, 1942; Capart, 1947; Capart, 1948), the method of host location remains unknown. Both the copepodid and the adult female stages of *L. branchialis* must locate and identify a suitable fish host to continue the life-cycle. It is likely that specific mechanisms are employed to initially locate a host and then ensure that it is suitable. The adult female spends 3-8 days on the intermediate host, depending on the number of times a female is inseminated (Anstensrud, 1990), indicating that insemination by a male is the trigger for the female to leave the intermediate host to search for a definitive host. *L. branchialis* is suggested to be a poor swimmer (Sproston, 1942) and it is unlikely that it swims any great distance to find a host. Consequently, the definitive host must inhabit the same area as the infected intermediate host for the parasite to transfer to the definitive host. If a suitable host is not located before the energy reserves of the parasite are depleted, it will die, although there have been instances where a metamorphosed adult female has been found to infect the nominal intermediate host (Schuurmans Stekhoven, 1936; Begg and Bruno, 1999) which may be a decision made by the parasite in the absence of any definitive hosts.

It is likely that there are several mechanisms involved to assist in host location and these may include mechano-reception to detect host movement and chemo-reception to recognise host associated chemical cues. The parasite may also use other physical

phenomena in the water column, such as thermoclines and haloclines, to search for likely concentrations of fish hosts.

1.1. Chemical cues

The use of chemical cues for host and mate location is common to most motile parasites and has been successfully demonstrated in many insects and copepods e.g. Griffiths and Frost (1976), Fraile *et al.* (1993), Pompanon *et al.* (1997), Takacs *et al.* (1997), Doall *et al.* (1998), Körner and Haas (1998), Dutton *et al.* (2000). In chemical ecology four main categories of chemical messengers have been recognised: pheromones, allomones, kairomones and hormones, although these groups are not mutually exclusive (Brown *et al.*, 1970). Of these, pheromones, allomones and kairomones are used to transmit chemical signals between organisms, whereas hormones transmit chemical messages between the cells of an organism.

The term pheromone was introduced by Karlson and Lüscher (1959) to describe a chemical signal emitted by an organism that triggers a behavioural or physiological response in a member of the same species. Pheromones can be divided into several different categories, for example, aggregation pheromones, alarm pheromones and sex pheromones and all are well documented in insects, e.g. Landolt and Phillips (1997), Al Abassi *et al.* (2000), Torto *et al.* (1994). The use of sex pheromones by planktonic copepods was first demonstrated by Katona (1973) where males of *Eurytemora affinis* (Poppe, 1880), *Eurytemora herdmani* Thomson and Scott, 1898 and *Pseudodiaptomus coronatus* Williams, 1906 were shown to respond to and locate females of the same species from up to 20mm away. The role of pheromones in courtship and mating of copepods has since been well documented, with the female producing pheromones that attract and affect the behaviour of the males in most cases

(Uchima and Murano, 1988; Ritchie *et al.*, 1996; Brewer, 1998; Doall *et al.*, 1998; Frey *et al.*, 1998; Hull *et al.*, 1998; Kelly *et al.*, 1998; Strickler, 1998; Tsuda and Miller, 1998; Weissburg *et al.*, 1998; Yen *et al.*, 1998; Ingvarsdottir *et al.*, 2002a). The aesthetascs (sensory hairs) on the antennules of the male are suggested to be the main site of chemoreception, with those of the male being much larger than those of the female (Griffiths and Frost, 1976). Pheromones produced by females are species specific and function as a mechanism to impede interbreeding between different species of copepods (Katona, 1973; Griffiths and Frost, 1976; Jacoby and Youngbluth, 1983).

An allomone is defined as a chemical, produced or acquired by an organism, which evokes a behavioural or physiological response in a receiving organism, which is favourable to the emitter (Brown, 1968). Most symbiotic partnerships are dependent to some extent on allomones (Brown *et al.*, 1970) and examples include the behavioural manipulation of leaf-cutter ants (*Atta* and *Acromyrmex* spp.) by their symbiont fungus *Attamyces bromatificus* Kreisel (Ridley *et al.*, 1996), and cardiac glycosides obtained from milkweed plants, that protect the monarch butterfly (*Danaus plexippus*) against predation from birds due to their foul taste (Reichstein *et al.*, 1968).

Whereas an allomone benefits the emitting organism, a kairomone is a chemical which benefits the receiving organism (Brown *et al.*, 1970) and includes a huge variety of chemicals which perform a number of roles such as attractants and stimulants that draw predators to their prey, herbivores to their food plants, and parasites to their hosts. As kairomones can perform a number of different functions, they can be further classified into foraging kairomones, enemy-avoidance kairomones, sexual kairomones and aggregation kairomones (Ruther *et al.*, 2002). In insects, examples include the predation by yellowjacket wasps (Vespidae) of Mediterranean

fruit flies that are using pheromones to attract a mate (Tephritidae) (Hendrichs *et al.*, 1994); kairomone controlled host recognition of the rice white-backed planthopper, *Sogatella furcifera* (Horvath), by the parasitoid wasp, *Anagrus nilaparvatae* Pang et Wang (Lou and Cheng, 2001); and the attraction of fungivorous beetles to volatiles of the bracket fungi *Fomitopsis pinicola* Karst and *Fomes fomentarius* (L.) (Faldt *et al.*, 1999).

In planktonic organisms, kairomones are known to play a number of roles including prey detection, predator avoidance and host location by parasites. The role of kairomones in plankton was first demonstrated in rotifers (De Beauchamp, 1952) and has since been studied extensively. Studies have shown that predator avoidance kairomones affect predator efficiency and, therefore, influence the trophic structure of an ecosystem (Lass and Spaak, 2003). This allows a much more complex community and a larger niche overlap between predators (Matsuda *et al.*, 1994). Fish-derived chemicals in the water have been shown to affect several life history traits of the cladoceran *Ceriodaphnia cf. dubia* Richard, 1894, including generation length, brood size, population growth rate and net productive rate, and is thought to be an adaptation to maximise reproductive output when the risk of predation is higher (Rose *et al.*, 2001). Fish kairomones also enhance the vertical diel migrations of *Daphnia*, which are used as a predator avoidance behaviour (Van Gool and Ringelberg, 2002). The calanoid copepods *Eudiaptomus gracilis* and *E. graciloides* are predators of *Daphnia*, but also use fish kairomones for predator avoidance, and use *Daphnia* as living shields against predation when they are present in high numbers (Jamieson, 2005).

A number of studies have focused on the use of kairomones for host location in parasitic planktonic organisms. In the cercariae of *Pseudechinoparyphium echinatum* Siebold, 1837 and *Echinostoma revolutum* (Fröelich, 1802) amino acids released from

their snail hosts are used to locate their hosts (Körner and Haas, 1998). The cercariae respond to a particular concentration of amino acids and not specific compounds, demonstrating that they are not host specific. In comparison, the cercariae of *Diplostomum spathaceum* (Rudolphi, 1819) respond to a unique combination of cues specific to their fish hosts (Haas *et al.*, 2002). The cues for host location and attachment of these cercariae are very non-specific and include carbon dioxide, water currents and touch and they will attach to any animal substrate (Haas, 1974a,b,1975). However, once attached, they penetrate the tissues of the host and if the chemical cues specific to fish are not detected, they will detach and continue searching for a suitable host (Haas *et al.*, 2002).

The use of chemo-reception for host location was originally demonstrated in caligid by (Fraile *et al.*, 1993) where mucus from sea bass (*Dicentrarchus labrax* (L.)) was shown to alter the behaviour of *Caligus minimus* (Otto, 1821). More recently *Lepeophtheirus salmonis* (Krøyer, 1837) have been shown to employ chemo-reception to recognise host associated chemical cues (Devine *et al.*, 2000). *L. salmonis* demonstrate increased activity and positive rheotaxis when exposed to exudates from Atlantic salmon (*Salmo salar* L.), but not from turbot (*Scophthalmus maximus* Rafinesque), demonstrating the use of kairomones by *L. salmonis* for host location as well as host recognition (Devine *et al.*, 2000). Extraction of low molecular weight compounds from salmon conditioned water by using solid-phase extraction techniques has shown that *L. salmonis* demonstrates a behavioural response and an electrophysiological response in their antennae to the chemicals isophorone and 1-octen-3-ol (Ingvarsdottir *et al.*, 2002b). As well as utilising chemical cues for host location, *L. salmonis* has also been shown to use mechano-reception to detect host

movement (Bron *et al.*, 1993; Heuch and Karlsen, 1997) and, in adult stages, a pronounced shadow response to passing fish (Bron, *pers. comm.*).

1.2. Behaviour analysis methods

In order to study the behaviour of organisms and quantify their response to chemical cues, many different techniques have been developed. The first consideration is whether to observe behaviour in two dimensions or three dimensions. Two dimensional data is easier to record and interpret than three dimensional data and is useful when the objective is either to observe the use of defined zones in an arena by an animal, or when the animal is presented with simple choices. Many studies utilise “choice chambers” where an animal is required to make a choice depending on the different stimuli that it is presented with e.g. Carte and Faulkner (1986), Boudreau *et al.* (1993). These choice chambers are often Y-shaped, where a different stimulus is added to each arm, but can be any shape with any number of arms. As the medium (either air or water) flows down each arm and merges into the main arm, the animal orientates towards the flow and chooses one arm or the other. Y-shaped choice chambers have been used to good effect for kairomone studies with *L. salmonis*, where different exudates from several species of fish were introduced into the chamber with a sea water control and choices made by the parasites, as well as their behaviour patterns, were recorded (Devine *et al.*, 2000; Ingvarsdottir *et al.*, 2002b).

If the natural behaviour of an organism is being investigated, a choice chamber is not suitable as it limits the movement of the animal. A more suitable option would be to use a larger cube-shaped arena and to record the movements of the animal in three dimensions. Recording movements in three dimensions can be achieved by using two orthogonally mounted cameras, one to record from the front (x,z axes) and the other to

record from the side (y,z axes) e.g. Strickler (1985), Hwang *et al.* (1993), Strickler (1998), Nihongi *et al.* (2004), Seuront *et al.* (2004a). However, this requires a complex setup involving dedicated computer software and synchronisation of the two cameras to ensure frames are recorded simultaneously. A simpler setup, using one video camera mounted above the arena, recording the horizontal movements of the animal in the arena ($x-y$ plane) and its vertical movements in a mirror mounted at 45° alongside the arena ($y-z$ plane), can be used at the cost of reduced resolution, as the field of view is split in two (Chrásková *et al.*, 1999). A similar setup has also been demonstrated using a series of mirrors to project two orthogonal views of an aquarium, representing the $x-z$ and $y-z$ planes, into a single video camera lens (Van Duren and Videler, 1995).

Once the movements of the animal have been recorded, they can be quantified by using one or a combination of several different methods, which can be facilitated by the use of specialised computer software (e.g. Motion Analysis Corporation, Santa Clara, CA, USA; Ethovision, Noldus Information Technology, Wageningen, The Netherlands). Motion can be described by using 3D positional data at discrete points in time (e.g. x, y, z) and using these to calculate parameters, for example, velocity, distance travelled, arena coverage, turn rate and meander. However, this can lead to a large quantity of data that is difficult to analyse for behaviour patterns.

Other methods exist to describe swimming paths to enable them to be easily quantified and compared, such as the net to gross displacement ratio (NGDR), which is defined as the ratio between the shortest distance between the start and finish of a swimming path and the total distance an animal travelled (Busky, 1984), and can be used to give a simple estimate of the turning behaviour of an animal. A further method of describing the motion of animals is by the finite helix fit (FHF), which is based on

the geometry of three dimensional curves that can be described by velocity, trajectory and torsion (Crenshaw *et al.*, 2000). This method has the advantage over traditional Euclidean geometry in that a track is completely described by the three parameters, simplifying behaviour patterns and allowing easy comparison of different behaviour patterns.

Fractal analysis, however, can reveal patterns in animal behaviour that may not be detectable using Euclidean geometry and have the added advantage that they are independent of scale. A fractal is described as “a rough or fragmented geometric shape that can be sub-divided in parts, each of which is (at least approximately) a reduced-size copy of the whole” (Mandelbrot, 1982). As fractals are scale-invariant, they can effectively describe behaviour patterns that appear complex by the use of power laws, which are characterised by scaling exponents (Hastings and Sugihara, 1993). In plankton studies, fractals have been used to study swimming and search behaviour in clownfish larvae (*Amphiprion perideraion* Bleeker, 1855) (Coughlin *et al.*, 1992), swimming behaviour in the copepod *Oncaea venusta* Philippi 1843 (Seuront *et al.*, 2004), and mating behaviour in the copepod *Leptodiptomus ashlandi* (Marsh 1893) (Uttieri *et al.*, 2007). One method of using fractals to characterise plankton behaviour is the “box-counting method” detailed by Seuront *et al.* (2004b) and Uttieri *et al.* (2005) and based on the power law relationship described by Loehle (1990) (see Chapter 2 for details).

1.3. Experiment objectives

The purpose of this experiment was to identify the role of host-associated chemical cues in host location by adult female *L. branchialis* by analysing the parasites behavioural responses to a range of host-derived cues. A Y-shaped choice chamber

was used to view the response of the parasites when provided with the option of seawater containing fish derived chemicals or clean seawater. Two hypotheses were generated which were tested using the choice chamber:

1. Adult female *L. branchialis* will choose water exposed to the definitive host over clean sea water.
2. Adult female *L. branchialis* will show minimal preference to chemicals from other fish species, including non-target species and intermediate host species, over clean sea water.

2. Materials and methods

2.1. Equipment design and setup

A choice chamber was constructed from 11mm thick clear acrylic (Figure 4.1). A concave Y-shaped channel of 8mm depth was cut into the acrylic. A drainage channel was cut at the base of the Y-shape to allow water to drain and a piece of 50 μ m nylon mesh was glued across the opening to prevent parasites from escaping. The whole chamber was spray painted white to provide contrast against the pigmented parasite. The choice chamber was placed onto a sheet of white foam board raised inside a shallow tray. A hole drilled into the board allowed waste water to drain into the tray below (Figure 4.2a). A Sony Handycam DCR-VX2000E-PAL video camera (f = 6-72mm, 58mm +2 diopter closeup lens) was fixed onto a copystand with the camera lens 40cm above the choice chamber (Figure 4.2b). Adult *L. branchialis* are phototaxic and since it would be impossible to conduct experiments with no light, a light diffuser was constructed to ensure there were no point sources of light which

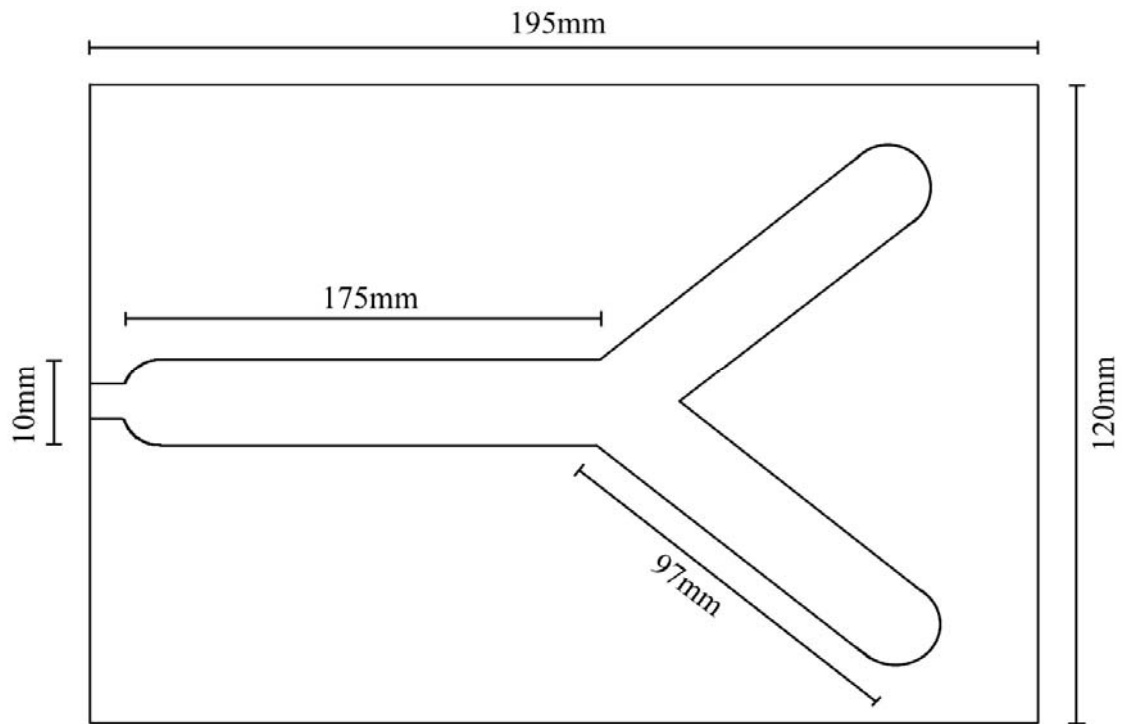

Figure 4.1. Schematic diagram of the choice chamber constructed from 11mm thick acrylic.

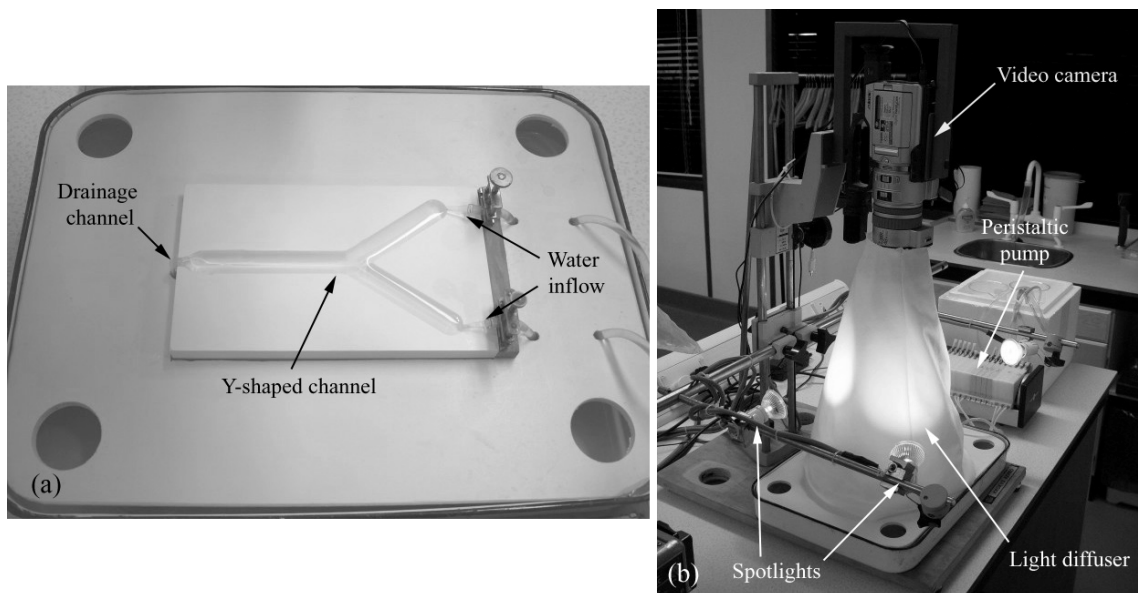

Figure 4.2. (a) The choice chamber set up with inflow tubes and drainage channel. (b) The choice chamber experimental setup, showing the video camera, peristaltic pump, light diffuser and spotlights.

would attract the parasites. This consisted of a double layer of cotton cloth, sewn into a conical shape and with a wire ring sewn in at the base to keep the shape. The top opening of the diffuser was attached to the video camera lens aperture with elastic bands (Figure 4.2b).

Four 12W halogen lights were mounted in a frame surrounding the light diffuser and a rheostat was wired in series to allow the light intensity to be adjusted (Figure 4.2b). The maximum contrast between the background and the parasite was achieved with the rheostat set at 120V. All other lights were switched off in the room and the experiments were conducted in the hours of darkness. A light meter (Sekonic L398 Studio Deluxe) was used to check that the light levels inside the diffuser were consistent and that there were no bright spots.

A Watson-Marlow 16-channel peristaltic pump (Watson-Marlow Ltd) was used to introduce water into the choice chamber and ensure even flows in each arm of the chamber (Figure 4.2b). Six Watson-Marlow Marprene manifold tubes (1.85mm internal diameter) were used, with each tube having a flow rate of 0.33ml/ sec and three channels were used for each arm of the choice chamber, giving a flow rate of 10ml/ min for each arm.

The video camera was connected via a composite video cable to a “Win TV” video capture card (Hauppauge) which was set to record at a rate of 1 frame/ sec and a resolution of 352 x 288 pixels, and digital video files were stored on a pc hard drive in avi format.

2.2. Experiment design

Flounder infected with *L. branchialis* were collected and the adult parasites were removed from the fish according to the methods detailed in Chapter 2. Details of the preparation of the chemical cues can also be found in Chapter 2.

For each different cue source two beakers of sea water, one containing the cue source and the other containing clean sea water, were kept on ice to maintain the water temperature at 10°C, which was monitored with a thermometer in each beaker. Water containing the cue source was introduced into one arm of the choice chamber and clean sea water was introduced into the other using the peristaltic pump. A trial was conducted using red food dye in one arm to ensure that water from both arms mixed evenly in the main arm of the choice chamber.

For each experiment, a single adult female *L. branchialis* was introduced into the chamber at the end of the long arm, close to the drain, with the pump running. The parasite was given time to settle for around one minute and once it began to respond to the flow of water the movements of the parasite were recorded using the video camera for 5 minutes. Thirty replicate individuals were recorded for each cue source from each fish species and the sea water control, giving a total of 510 replicates i.e. $((30 \times 4) \times 4 + 30)$. Random switching of the cue source arm and orientation of the chamber (either left or right) between replicates ensured that any other potential directional cues, such as light, vibration or magnetic fields, would not affect the outcome of the experiments. Between each different cue source the chamber and pump tubes were cleaned thoroughly by pumping 500ml of dilute decon (~0.5g dry decon in 500ml water) through the system followed by 1 litre of clean sea water. The next cue source was pumped through the system until it filled the choice chamber and was overflowing from the drain before the next set of experiments was begun.

2.3. Data extraction and analysis

Data were extracted from the video files using KS300 image analysis software and the dedicated Paratrack software according to the methods described in Chapter 2. A combination of univariate and multivariate techniques were used to analyse the behavioural information calculated in Paratrack. Each chemical cue was compared to the baseline control by calculating the difference between the cue and control for each replicate of each behaviour parameter. A one-way analysis of variance (GLM ANOVA) with a Dunnett *post-hoc* test was used to statistically compare each cue to the control. A principal component analysis (PCA) was used to extract patterns in the data that were not evident using univariate techniques. Finally the data were analysed using discriminant analysis, which is designed to predict group membership from a set of predictors (i.e. behaviour parameters). All statistical analyses were made using Statistica software version 7.1 (StatSoft Ltd.).

3. Results

Generally, there was a degree of variation in the behaviour of individual parasites, resulting in considerable spread of the data around the mean values, making it difficult to find patterns in the behaviour of *L. branchialis* when presented with different chemical cues. However, before any attempt can be made to assess how different chemical cues may change the behaviour of the parasites, it is necessary to analyse their normal behaviour without the addition of chemical cues and establish a baseline.

3.1. Comparison with control

L. branchialis control parasites spent over half of the time ($51.8 \pm 39.5\%$) in the mixed zone of the choice chamber (Table 4.1). The other portion of the time was spent in the cue zone ($31.2 \pm 35.1\%$) and the control zone ($17 \pm 31.3\%$). However, the large

Table 4.1. *Lernaeocera branchialis* behaviour statistics for choice chamber control (clean sea water) experiments, observed over a five minute period (n = 30). All parameters were calculated in Paratrack.

	Mean (\pm St. dev.)
Time in mixed zone (%)	51.8 (39.5)
Time in cue zone (%)	31.2 (35.1)
Time in control zone (%)	17.0 (31.3)
Number of periods in mixed zone	1.9 (1.4)
Number of periods in cue zone	1.2 (1.5)
Number of periods in control zone	0.9 (1.5)
Length of period in mixed zone (secs)	130.8 (126.6)
Length of period in cue zone (secs)	68.1 (98.1)
Length of period in control zone (secs)	30.4 (69.8)
Mean velocity (mm / sec)	4.0 (2.4)
Maximum velocity (mm / sec)	20.4 (11.2)
Distance travelled (cm)	118.8 (72.8)
Time spent moving (secs)	234.9 (67.5)
Time spent immobile (secs)	64.1 (67.5)
Number of swimming bouts	13.0 (14.1)
Duration of swim bouts (secs)	114.1 (127.2)
Mean distance travelled during swim bout (cm)	73.2 (91.6)
Mean velocity during swim bouts (mm / sec)	4.7 (2.2)
Number of immobile bouts	12.5 (14.6)
Duration of immobile bouts (secs)	10.2 (25.2)
Mean heading (degrees)	120.1 (39.3)
Turn rate (degrees / sec)	130.1 (46.4)
Meander (degrees / mm)	44.7 (27.0)

standard deviations indicate that these proportions showed considerable variation between replicates. The mean number of periods in each zone was similar for the three zones and also showed some variation. Consequently, the mean period length was greater in the mixed zone (130.8 ± 126.6 secs) than the cue zone (68.1 ± 98.1 secs) and the control zone (30.4 ± 69.8 secs). The maximum velocity of 20.37 ± 11.16 mm / sec was considerably greater than the mean velocity of 3.97 ± 2.43 mm / sec, indicating that *L. branchialis* is capable of quick bursts of speed and indeed the maximum velocity of one parasite was 60 mm / sec. On average, the parasites spent more time moving (234.9 ± 67.5 secs) than time spent immobile (64.1 ± 67.5 secs) and the mean distance travelled during the 5 minute experiment was 118.77 ± 72.8 cm. However some parasites covered a significantly greater distance, with a maximum for one parasite of 252.67 cm, whereas some parasites remained relatively immobile, the shortest distance travelled being 14.48cm. The parasites demonstrated intermittent “stop-start” behaviour with a mean of 13 ± 14.1 swimming bouts. However, the swimming bouts tended to be much longer (mean 114.2 ± 127.2 secs) than the immobile bouts (mean 10.2 ± 25.2 secs). A high amount of turning was seen in the control parasites with a mean turn rate of 130.1 ± 46.4 degrees / sec and mean meander of 44.7 ± 27.0 degrees / mm.

The most striking observation from the comparison of the different chemical cues with the baseline control is the considerable variability between replicates, indicated by the large standard deviations. Although there were many differences between the cues and control, most were not significant due to this variability. Most of the significant parameters were from the flounder and trout cues and indicated repulsion from these cues. For instance, parasites exposed to flounder faeces, trout conditioned water, trout mucus and trout faeces spent significantly less time in the cue zone than the control

Table 4.2. Significance values for all different cue types compared to the baseline control, calculated from a one-way analysis of variance (GLM ANOVA) with a Dunnett *post-hoc* test. Numbers indicate P values. WCW = whiting conditioned water, WM = whiting mucus, WF = whiting flesh, WFA = whiting faeces, CCW = cod conditioned water, CM = cod mucus, CF = cod flesh, CFA = cod faeces, FCW = flounder conditioned water, FM = flounder mucus, FF = flounder flesh, FFA = flounder faeces, TCW = trout conditioned water, TF = trout flesh, TM = trout mucus, TFA = trout faeces.

		WCW	WM	WF	WFA	CCW	CM	CF	CFA	FCW	FM	FF	FFA	TCW	TM	TF	TFA
Time in Zone	Mixed	<0.05	N/S	N/S	N/S	N/S	N/S	N/S	N/S	N/S	N/S	N/S	<0.001	<0.001	N/S	N/S	<0.05
	Cue	N/S	<0.05	N/S	N/S	<0.01	<0.01	N/S	<0.01	N/S	N/S	N/S	<0.001	<0.001	<0.001	<0.05	<0.001
	Control	N/S	N/S	<0.01	N/S	N/S	N/S	N/S	N/S	N/S	N/S	N/S	<0.01	<0.05	N/S	<0.05	N/S
Number of periods in zone	Mixed	N/S	N/S	N/S	N/S	N/S	N/S	N/S	N/S	<0.01	N/S	N/S	<0.05	N/S	N/S	N/S	N/S
	Cue	N/S	N/S	N/S	N/S	N/S	N/S	N/S	N/S	N/S	N/S	N/S	<0.01	N/S	N/S	N/S	N/S
	Control	<0.05	N/S	N/S	N/S	N/S	N/S	N/S	N/S	N/S	N/S	N/S	<0.05	N/S	N/S	N/S	N/S
Average length of period in zone	Mixed	<0.01	N/S	N/S	N/S	<0.05	N/S	N/S	N/S	N/S	N/S	N/S	<0.001	<0.01	N/S	N/S	<0.05
	Cue	N/S	N/S	N/S	N/S	<0.05	<0.01	N/S	<0.01	N/S	N/S	N/S	<0.01	<0.001	<0.01	N/S	<0.001
	Control	N/S	N/S	<0.05	N/S	N/S	N/S	N/S	N/S	N/S	N/S	<0.01	N/S	N/S	<0.05	N/S	N/S
Average velocity		N/S	<0.01	N/S	N/S	N/S	N/S	<0.05	0.001	<0.05	N/S	N/S	<0.001	<0.001	<0.01	N/S	N/S
Maximum velocity		N/S	N/S	<0.05	<0.05	<0.01	N/S	<0.05	<0.001	<0.05	<0.05	N/S	<0.05	N/S	<0.01	N/S	N/S
Distance travelled		N/S	<0.01	N/S	N/S	N/S	N/S	<0.05	<0.001	<0.05	N/S	N/S	<0.001	<0.001	<0.01	N/S	N/S
Time spent moving		N/S	N/S	N/S	N/S	N/S	N/S	N/S	<0.05	N/S	N/S	N/S	N/S	N/S	N/S	N/S	N/S
Time spent immobile		<0.001	N/S	N/S	N/S	<0.01	N/S	N/S	<0.05	N/S	N/S	N/S	<0.001	<0.001	<0.05	N/S	N/S

Table 4.2. Continued.

	WCW	WM	WF	WFA	CCW	CM	CF	CFA	FCW	FM	FF	FFA	TCW	TM	TF	TFA
Number of swimming bouts	<0.01	N/S	N/S	N/S	N/S	N/S	N/S	N/S	N/S	N/S	N/S	N/S	N/S	N/S	N/S	N/S
Average duration of swimming bouts	N/S	<0.001	N/S	N/S	N/S	N/S	<0.001	<0.01	<0.05	N/S	N/S	<0.001	<0.001	<0.01	<0.001	N/S
Average distance travelled during swim bouts	N/S	<0.001	N/S	<0.05	N/S	<0.05	<0.001	<0.01	<0.05	N/S	N/S	<0.001	<0.001	<0.01	<0.01	<0.05
Average velocity during swim bouts	N/S	<0.01	N/S	N/S	N/S	N/S	N/S	<0.001	N/S	<0.05	N/S	<0.001	N/S	<0.01	N/S	N/S
Number of immobile bouts	<0.01	N/S	N/S	N/S	N/S	N/S	N/S	N/S	N/S	N/S	N/S	N/S	N/S	N/S	N/S	N/S
Average velocity during swim bouts	N/S	<0.01	N/S	N/S	N/S	N/S	N/S	<0.001	N/S	<0.05	N/S	<0.001	N/S	<0.01	N/S	N/S
Number of immobile bouts	<0.01	N/S	N/S	N/S	N/S	N/S	N/S	N/S	N/S	N/S	N/S	N/S	N/S	N/S	N/S	N/S
Average duration of immobile bouts	N/S	N/S	N/S	N/S	N/S	N/S	N/S	N/S	N/S	N/S	N/S	N/S	<0.01	N/S	N/S	N/S
Average heading	<0.05	N/S	N/S	N/S	<0.001	N/S	N/S	N/S	N/S	N/S	N/S	<0.001	<0.001	N/S	N/S	N/S

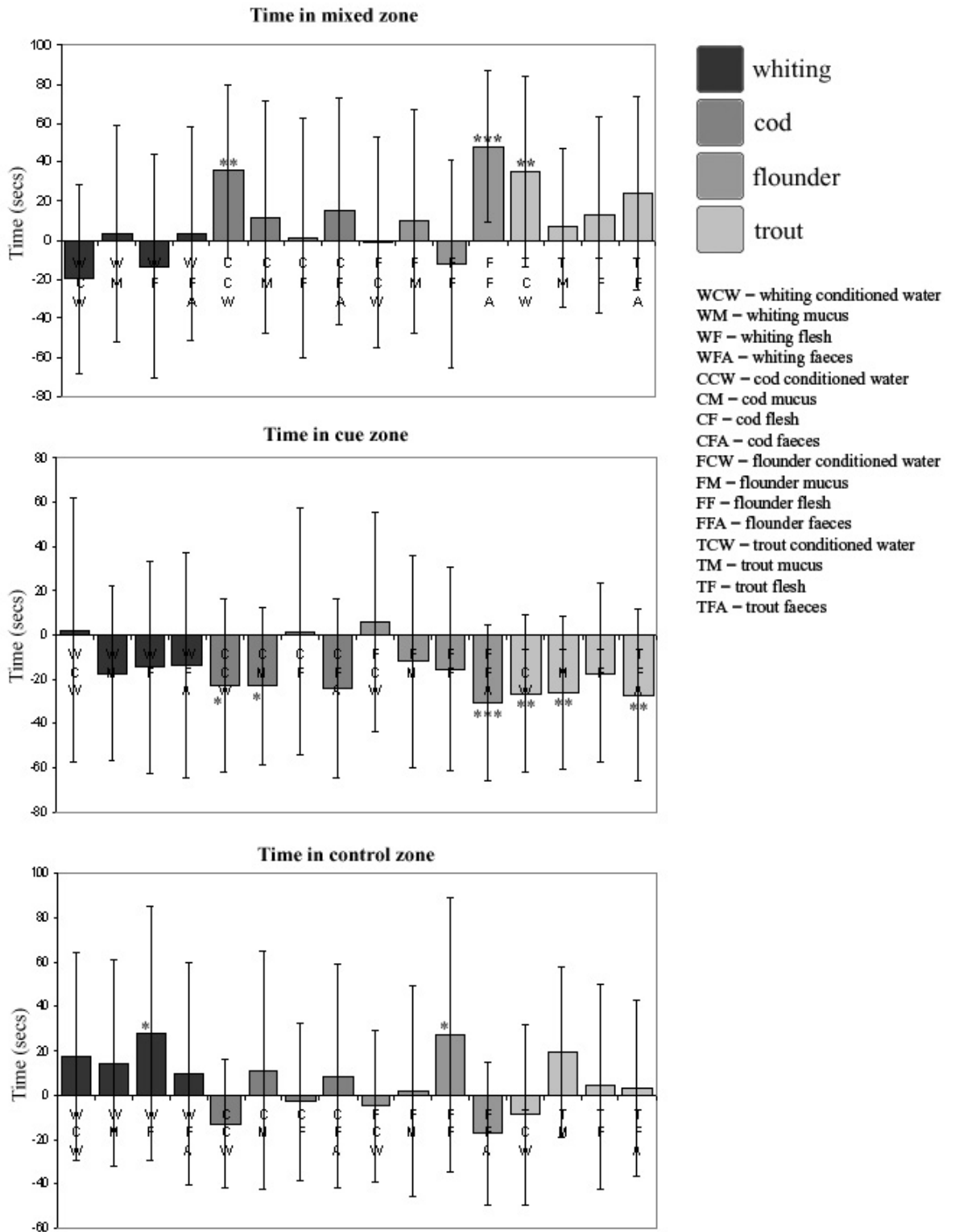

Figure 4.3. Comparison with baseline control of time spent by *L. branchialis* in different choice chamber zones for each chemical cue. Bars show mean \pm standard deviation. Significance: * = $P < 0.05$, ** = $P < 0.01$, *** = $P < 0.001$.

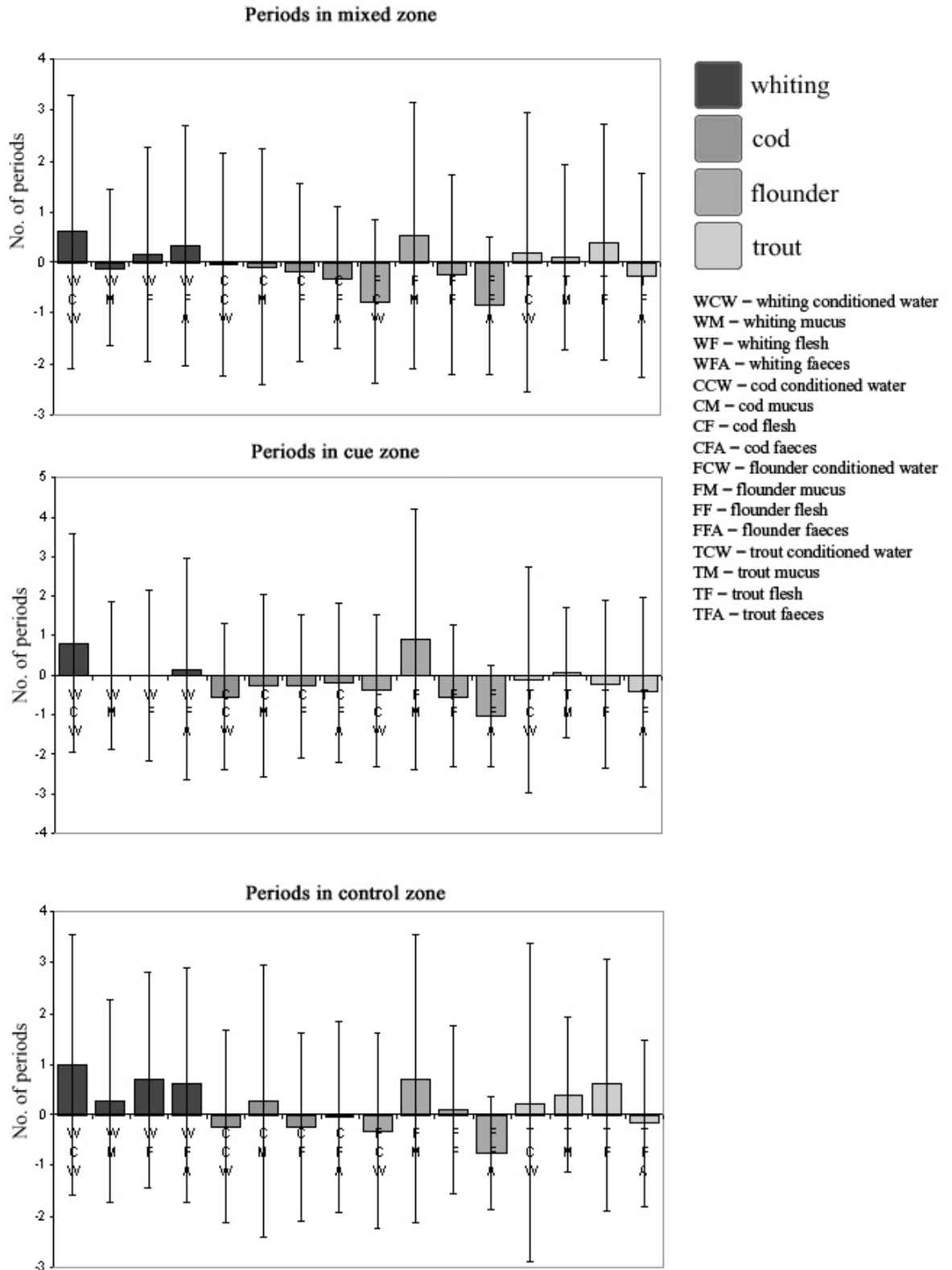

Figure 4.4. Comparison with baseline control of number of periods spent by *L. branchialis* in different choice chamber zones for each chemical cue. Bars show mean \pm standard deviation.

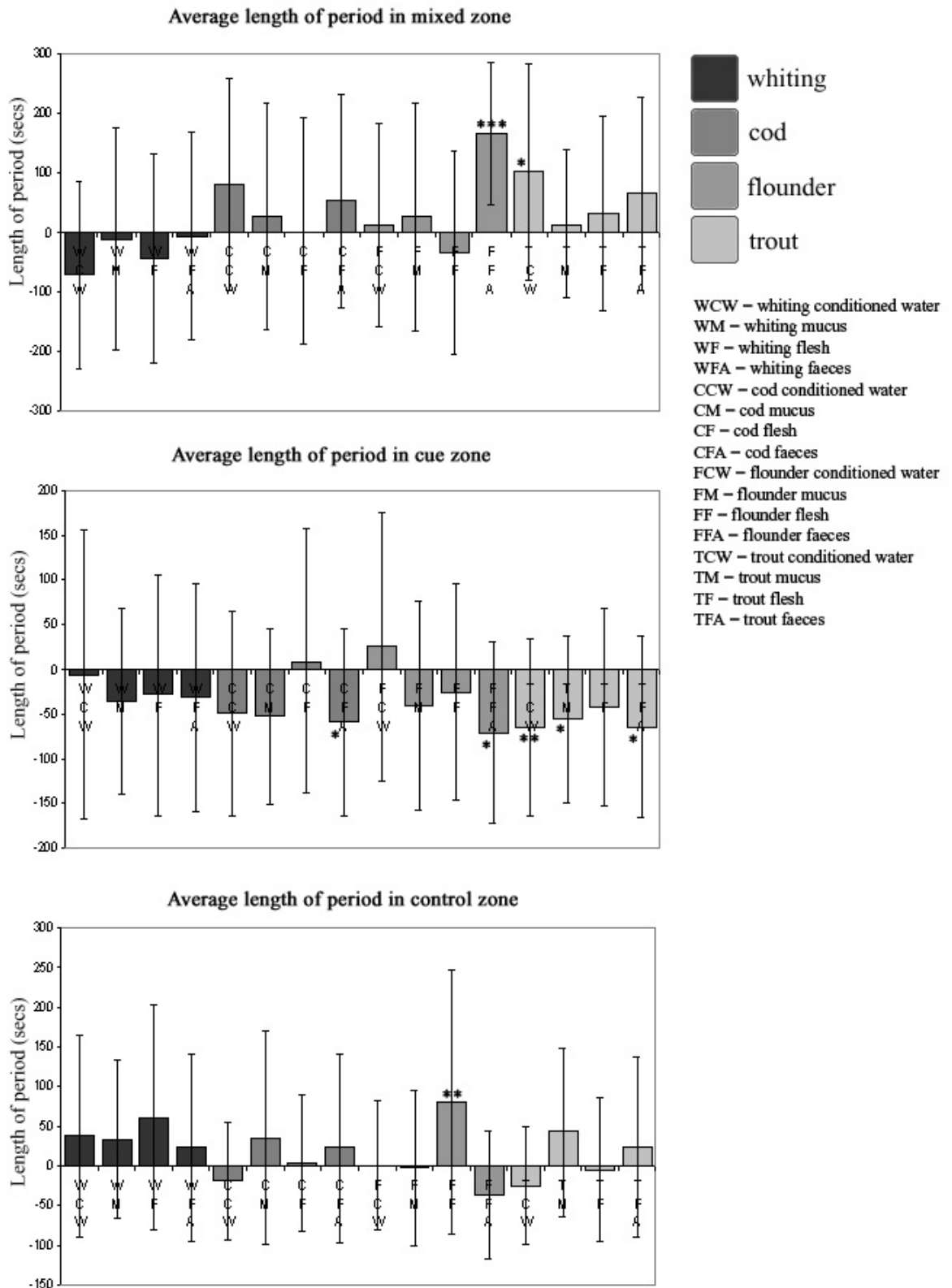

Figure 4.5. Comparison with baseline control of average length of each period spent by *L. branchialis* in different choice chamber zones for each chemical cue. Bars show mean \pm standard deviation. Significance: * = $P < 0.05$, ** = $P < 0.01$, *** = $P < 0.001$.

parasites ($P < 0.01$) (Figure 4.3). Instead, parasites in these groups spent more time in the mixed zone with flounder faeces and trout conditioned water being the most significant ($P < 0.01$ and $P < 0.001$, respectively). A similar pattern was seen for the average length of periods in each zone, where parasites exposed to flounder faeces, trout conditioned water, trout mucus and trout faeces spent significantly shorter periods in the cue zone and longer periods in the mixed zone (Figure 4.4). The mean number of periods spent in each zone was similar to the control parasites for all cues and showed high variability. Consequently none of these parameters were significant (Figure 4.5). Of all the definitive host cues (whiting and cod), only parasites in the whiting conditioned water and cod flesh groups spent more time in the cue zone than the controls and parasites in the whiting conditioned water and whiting faeces groups spent more periods in the cue zone than the controls. However, none of these parameters were significant.

Of all the cues tested, only parasites in the whiting conditioned water group had a higher mean velocity than the control parasites, although this was not significant (Figure 4.6). In all the other experiments, parasites had a lower mean velocity than the control parasites, with the flounder faeces and trout conditioned water groups being the most significant ($P < 0.001$). The highest maximum velocity from all experiments was seen in control parasites and, therefore, parasites from all other groups had a lower maximum velocity than the baseline control (Figure 4.6). Parasites exposed to whiting conditioned water were the only group to travel further than the control group, although again this was not significant. Parasites in all other groups travelled less distance than the control parasites, with the most significant being flounder faeces ($P < 0.001$), cod faeces and trout conditioned water ($P < 0.01$) (Figure 4.6).

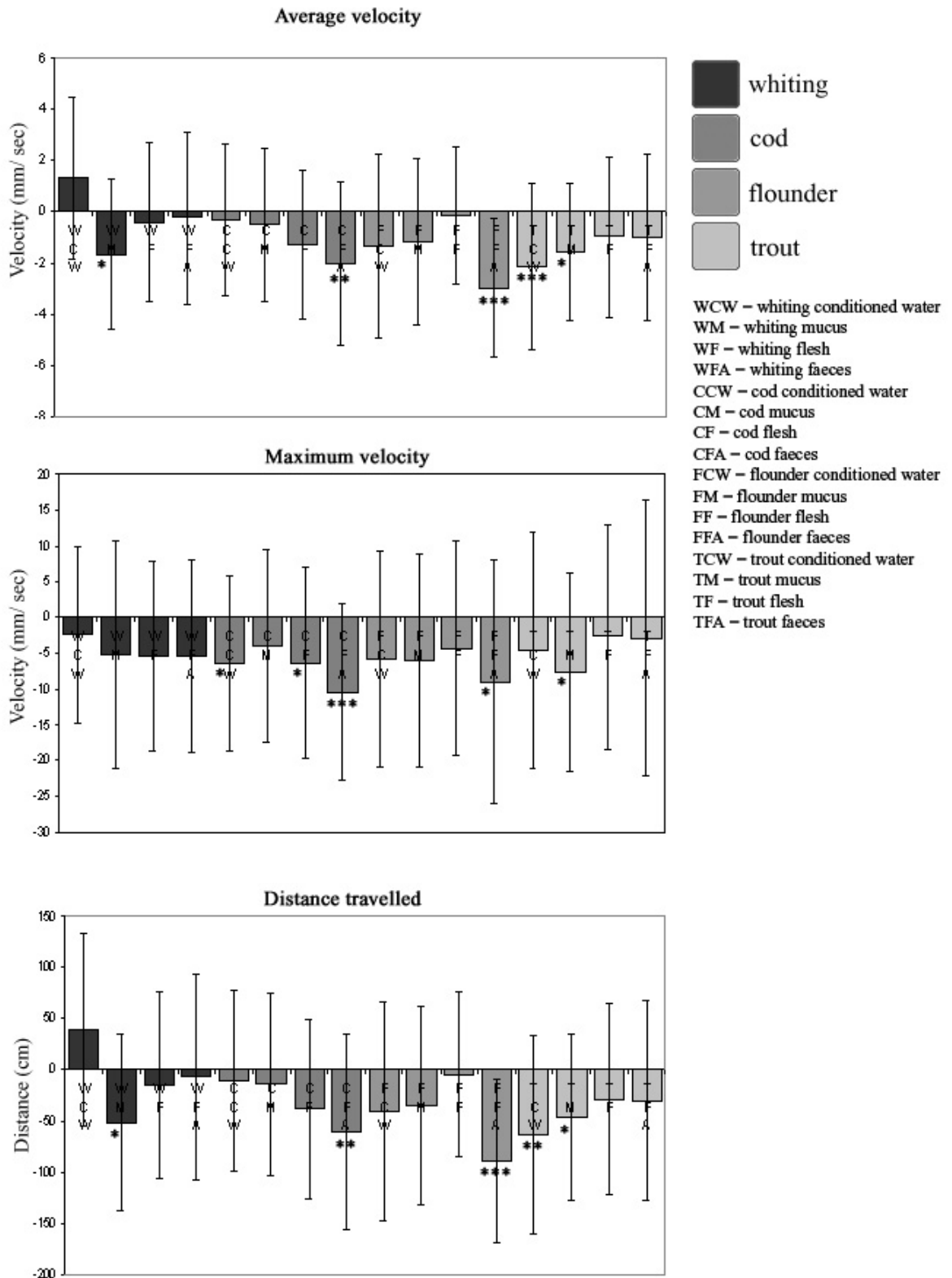

Figure 4.6. Comparison with baseline control of velocity and distance travelled by *L. branchialis* for each chemical cue. Bars show mean \pm standard deviation. Significance: * = $P < 0.05$, ** = $P < 0.01$, *** = $P < 0.001$.

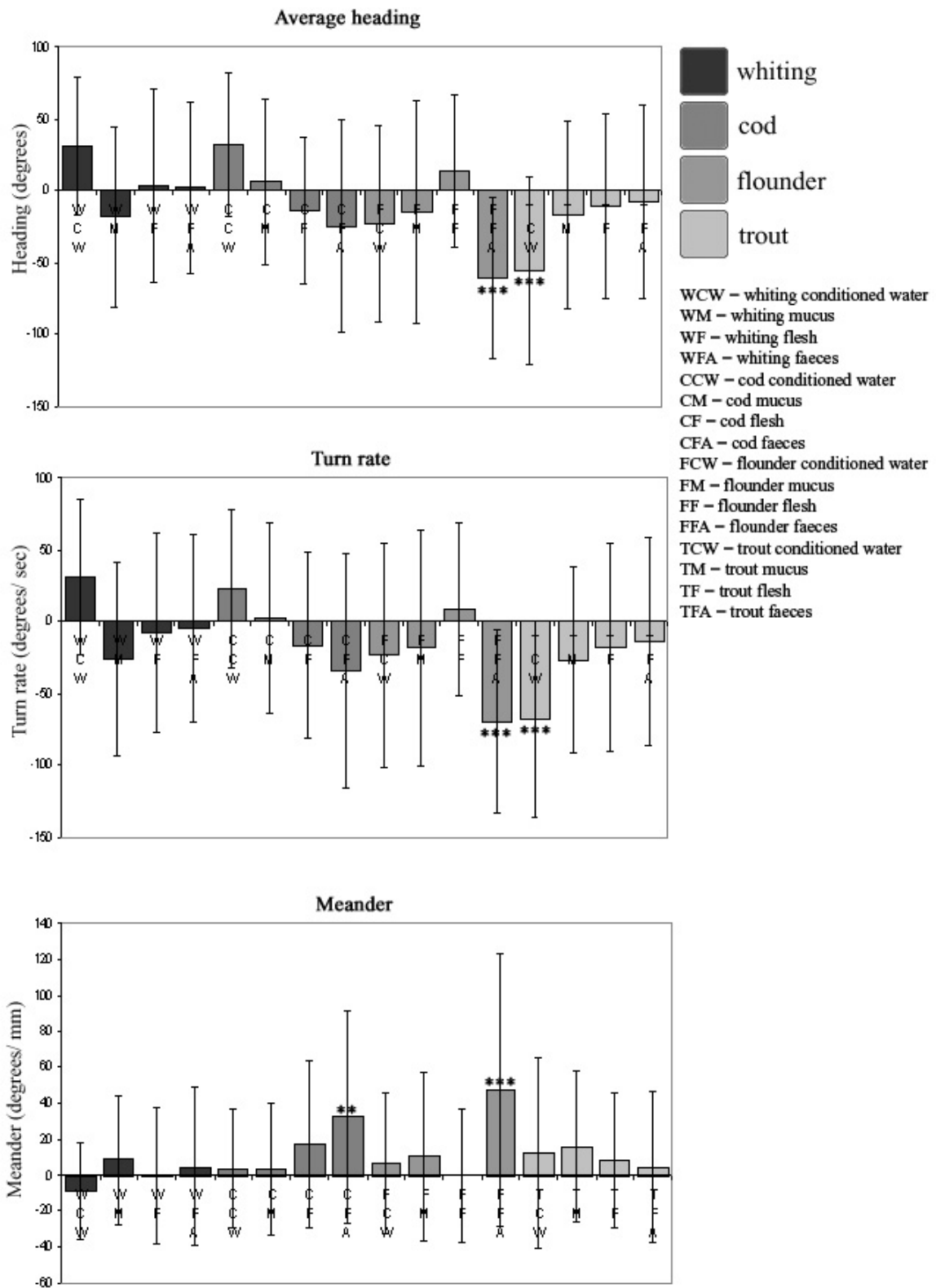

Figure 4.7. Comparison with baseline control of heading, turn rate and meander of *L. branchialis* for each chemical cue. Bars show mean \pm standard deviation. Significance: ** = $P < 0.01$, *** = $P < 0.001$.

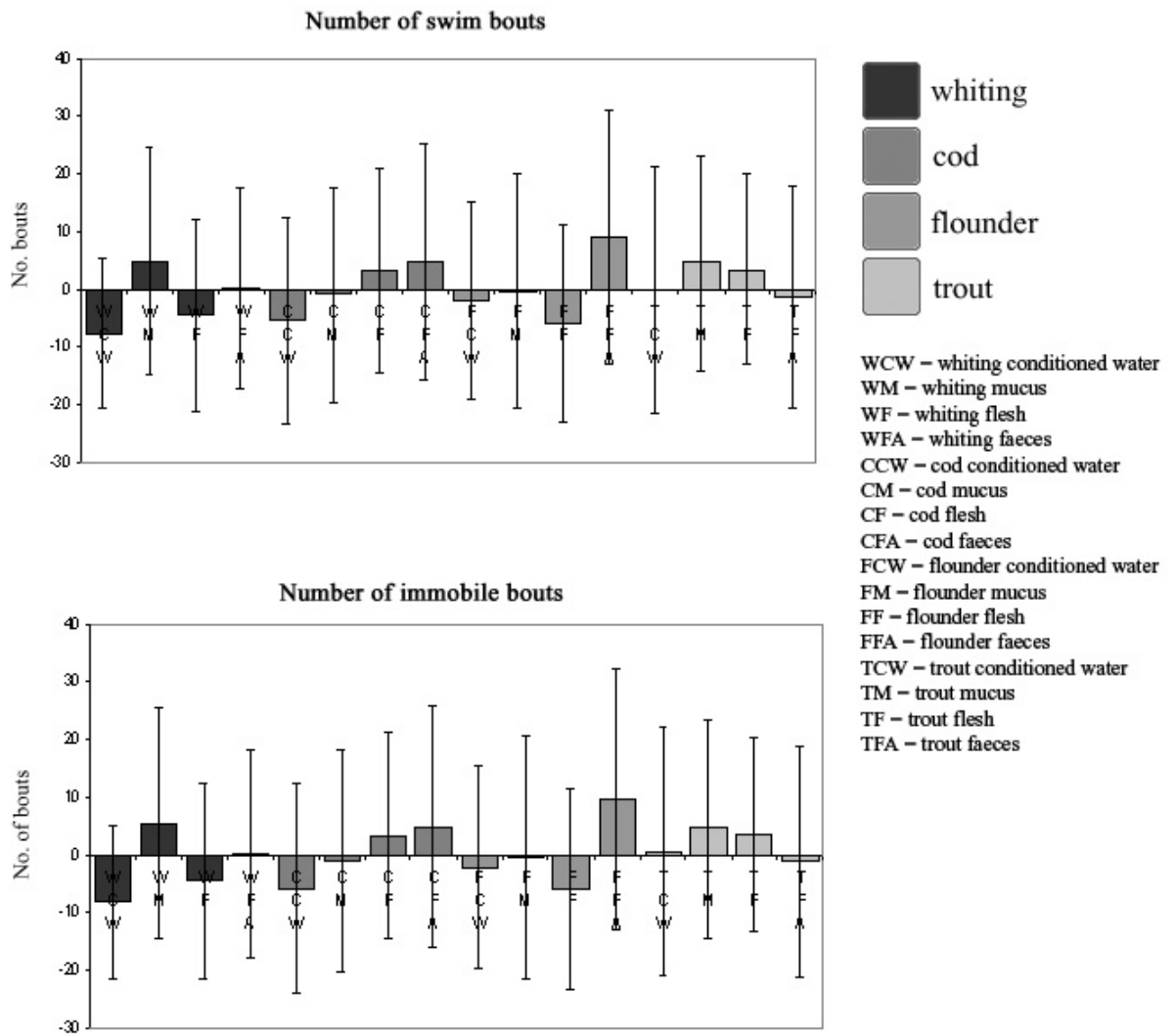

Figure 4.8. Comparison with baseline control of number of swimming and immobile bouts by *L. branchialis* for each chemical cue. Bars show mean \pm standard deviation.

Flounder faeces and trout conditioned water were the only groups to have a significantly lower turn rate than the control parasites ($P < 0.001$) (Figure 4.7). However the flounder faeces group meandered significantly more than the control group ($P < 0.001$), which is due to the short distance travelled by parasites in this group, so they turned more per unit of distance and less per unit of time than the control parasites (Figure 4.7). The number of swimming and immobile bouts was very

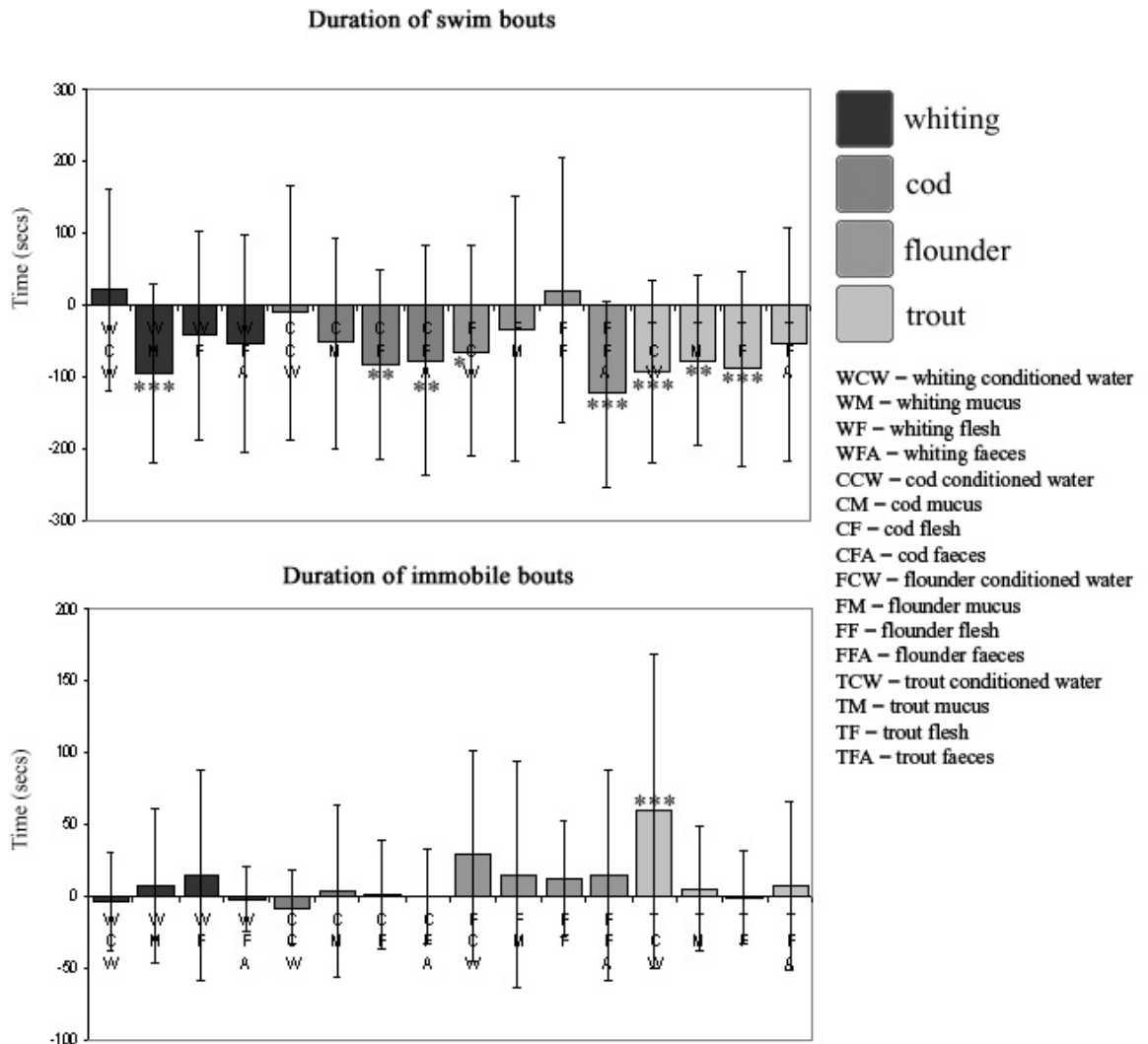

Figure 4.9. Comparison with baseline control of average duration of each bout by *L. branchialis* for each chemical cue. Bars show mean \pm standard deviation. Significance: * = $P < 0.05$, ** = $P < 0.01$, *** = $P < 0.001$.

variable for all cue groups and was not significant for any group (Figure 4.8). Parasites exposed to whiting conditioned water were the only group to have longer swimming bouts, travel further in swimming bouts and to swim at a greater velocity in swimming bouts, than the control group parasites, although this was not significant (Figures 4.8-10). In nearly all other groups, parasites had shorter swimming bouts,

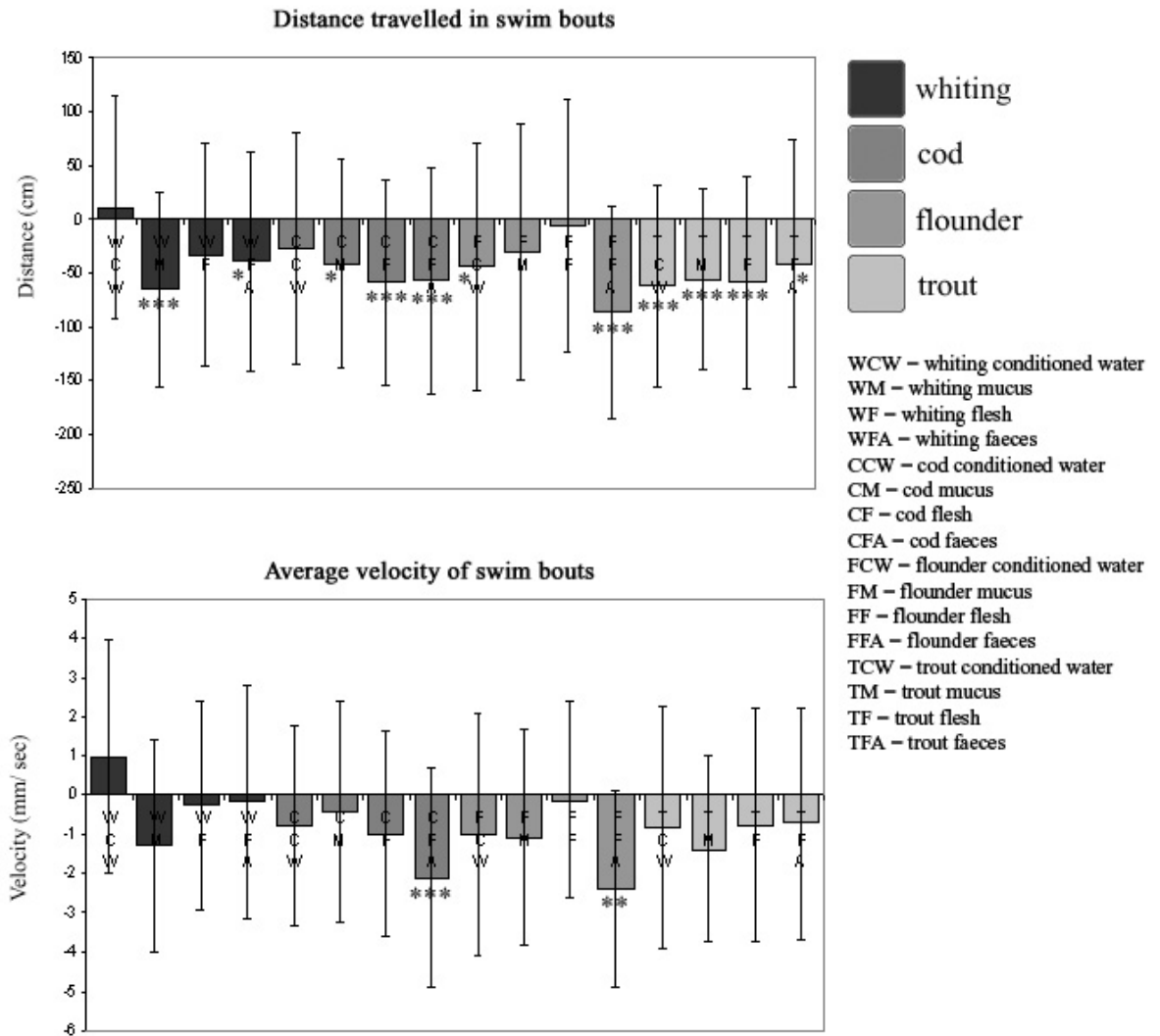

Figure 4.10. Comparison with baseline control of average velocity and distance travelled in each swim bout by *L. branchialis* for each chemical cue. Bars show mean \pm standard deviation. Significance: * = $P < 0.05$, ** = $P < 0.01$, *** = $P < 0.001$.

travelled shorter distances in swimming bouts and had a lower velocity in swimming bouts than the control group, with many of these (whiting mucus, whiting faeces, cod mucus, cod flesh, cod faeces, flounder faeces, trout conditioned water, trout mucus, trout flesh) being highly significant ($P < 0.001$) (Figures 4.9-10). Trout conditioned water had significantly longer immobile bouts compared to the control ($P < 0.001$)

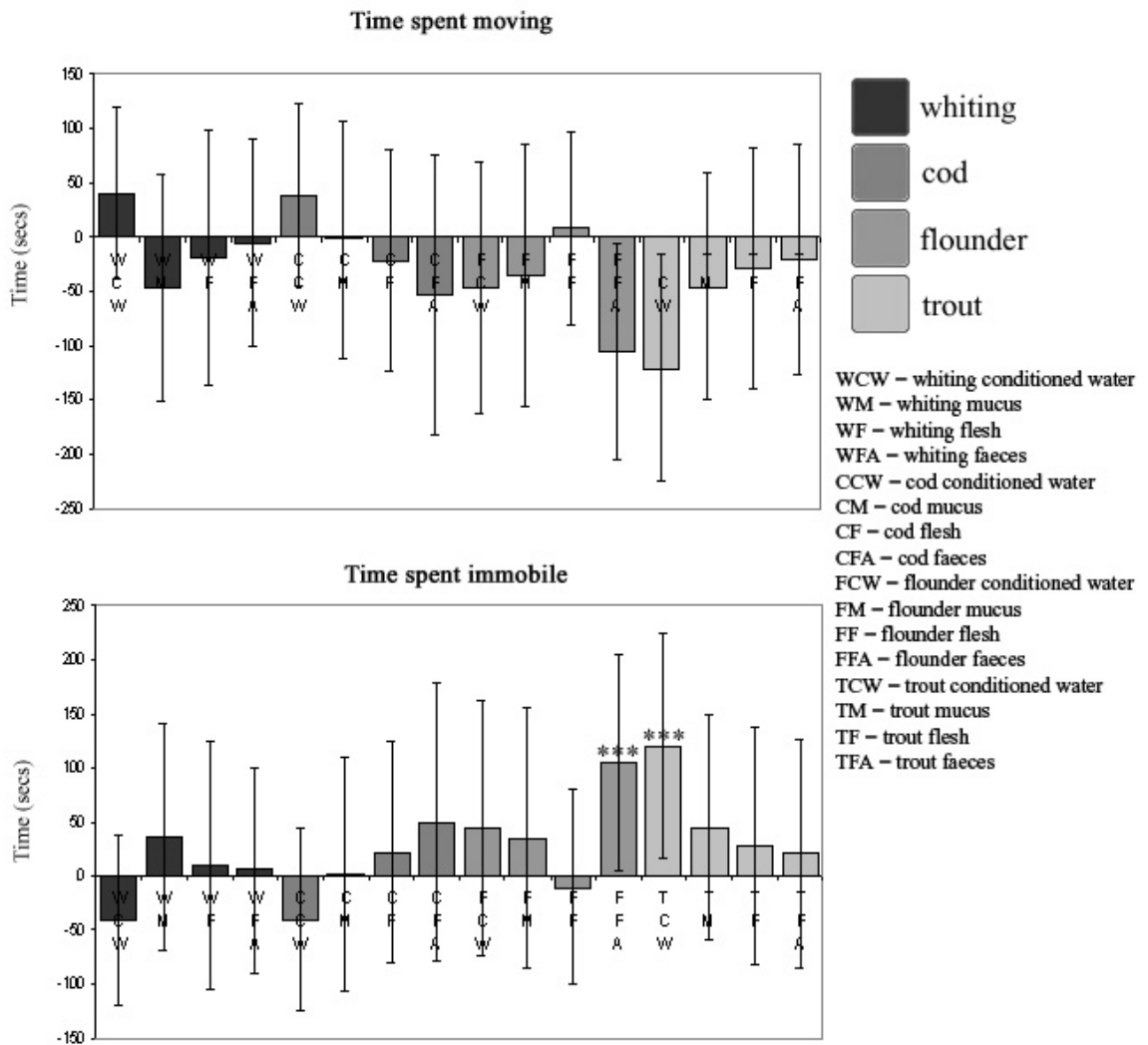

Figure 4.11. Comparison with baseline control of time spent moving and immobile by *L. branchialis* for each chemical cue. Bars show mean \pm standard deviation. Significance: *** = $P < 0.001$.

whereas in all other groups there was little variation in the duration of immobile bouts compared to the control (Figure 4.9). No parasite group spent significantly more or less time moving, although parasites exposed to whiting conditioned water, cod conditioned water and flounder flesh were the only groups to spend more time moving than the control parasites (Figure 4.11). As parasites that are not moving are immobile, the pattern of time spent immobile for different groups is a reciprocal of the

pattern seen for time spent moving, although the flounder faeces and trout conditioned water groups spent significantly more time immobile than the control group ($P < 0.001$) (Figure 4.11).

3.2. Principal Component Analysis

As many of the behaviour parameters are derived from other parameters or are the same or inverse values of other parameters, they were removed from the raw data set submitted to the PCA analysis. The parameters which were removed were: length of period in each zone, time spent immobile, length of swimming bouts, duration of swimming bouts, velocity of swimming bouts, immobile bout number and length of immobile bouts. The remaining parameters were transformed where necessary to make the data as normal as possible (Table 4.3).

Calculation of eigenvalues for the behaviour data with all different cues (23 variables) showed that Factors 1, 2 and 3 describe 42.52%, 11.17% and 10.39% of the total variation observed between specimens, respectively. Factors 1 vs. 3, and 2 vs. 3 were plotted but the data was found to be most effectively separated by Factors 1 and 2, so these were, therefore, used for subsequent analysis. A PCA was calculated for each cue type (Figure 4.12-13).

The results of the PCA show that the large variation seen in the dataset is common to all the data and not limited to a few outlying variables (Figures 4.12-13). Although groupings are visible, they show considerable overlap with other groups. Conditioned water separates the data most effectively, with whiting conditioned water and cod conditioned water forming two defined groups with only a few outlying points, although with considerable overlap (Figure 4.12a). Flounder conditioned water forms

Table 4.3. Data transformations used for different behaviour parameters prior to PCA analysis.

Parameter	Transformation
Time in mixed zone	Arcsine
Number of periods in mixed zone	Square root
Number of periods in cue zone	Square root
Number of periods in control zone	Square root
Average velocity	Log
Maximum velocity	Log
Distance travelled	Square root
Time spent moving	Arcsine
Number of swimming bouts	Log
Meander	Log

a group in a different plane, although less clearly defined, whereas trout conditioned water does not appear to show any defined grouping. However, all the groups show considerable overlap with the control group. Whiting mucus forms a distinct group but is separated in two different directions, although this overlaps with all the other mucus groups which show no clear pattern (Figure 4.13a). None of the flesh cues show any form of grouping and overlap completely with the control group (Figure 4.12b). Most of the flounder faeces and trout faeces data forms a tight group together which is distinct from the control group, whereas the whiting faeces and cod faeces groups do not show any clear pattern and overlap with the control group (Figure 4.13b).

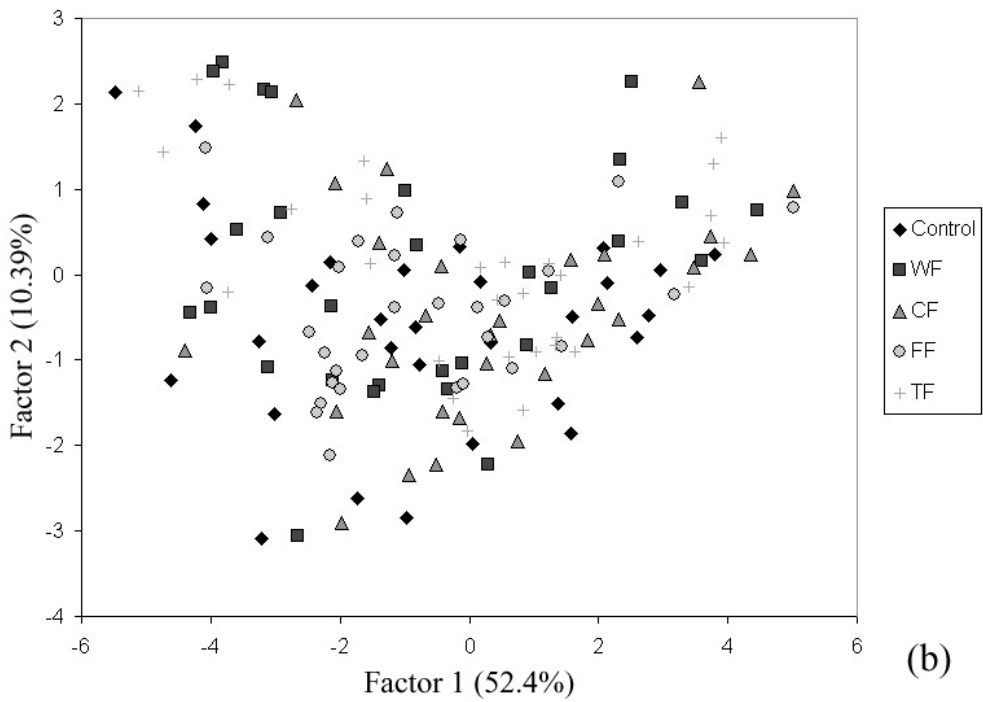
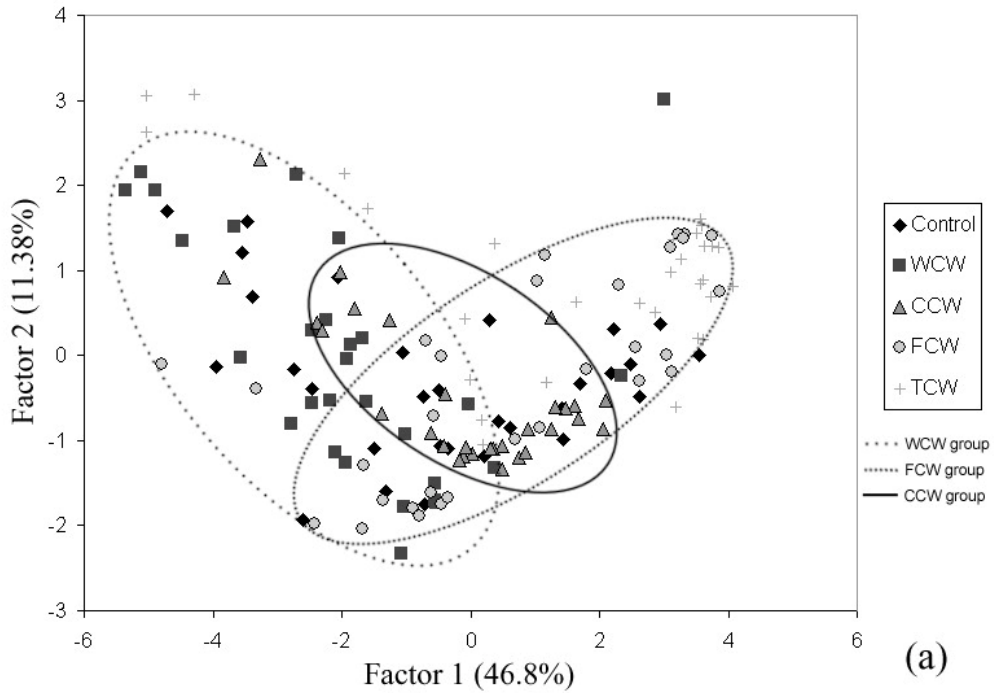

Figure 4.12. PCA for different chemical cue types. (a) Conditioned water, (b) flesh. Ellipses delineate groupings. WCW = whiting conditioned water, CCW = cod conditioned water, FCW = flounder conditioned water, TCW = trout conditioned water, WF = whiting flesh, CF = cod flesh, FF = flounder flesh, TF = trout flesh.

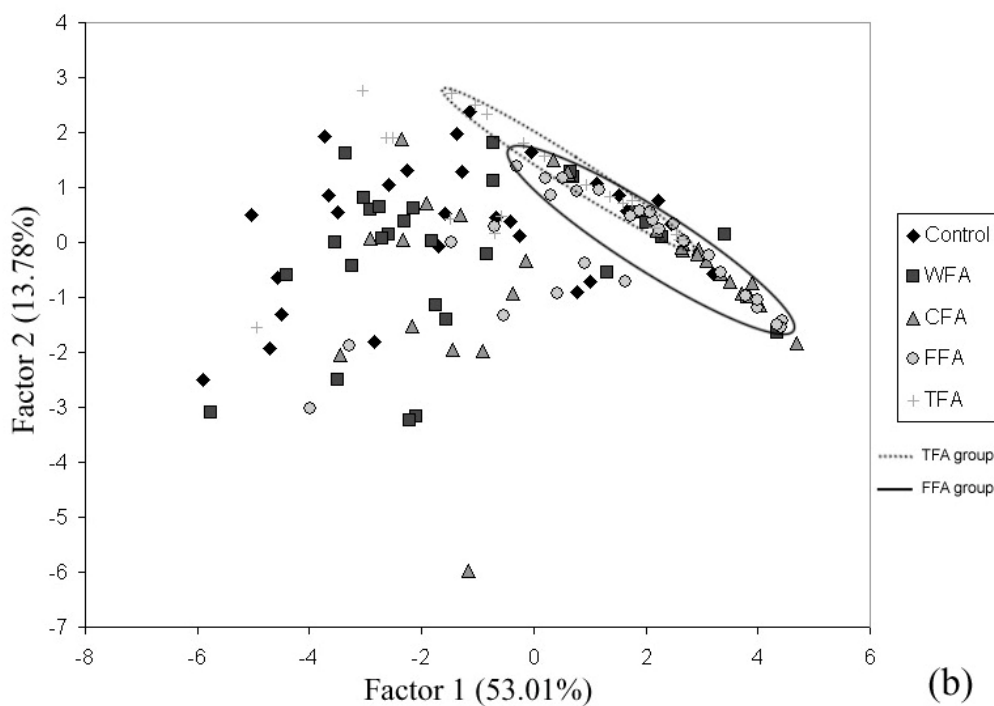
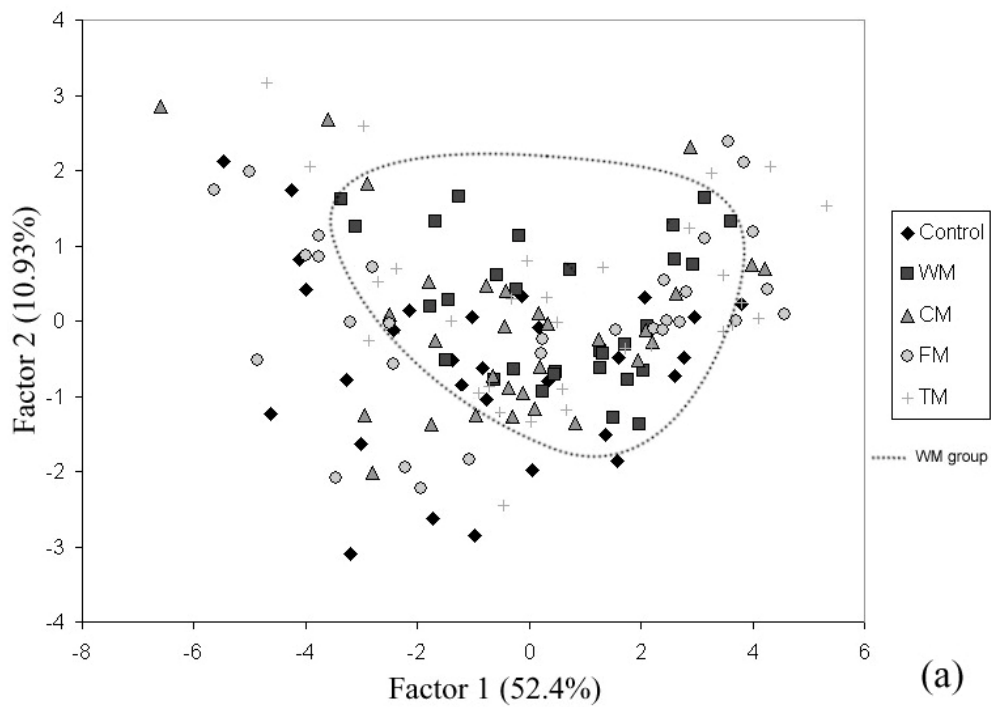

Figure 4.13. PCA for different chemical cue types. (a) mucus, (b) faeces. Ellipses delineate groupings. WM = whiting mucus, CM = cod mucus, FM = flounder mucus, TM = trout mucus, WFA = whiting faeces, CFA = cod faeces, FFA = flounder faeces, TFA = trout faeces.

3.3. Discriminant analysis

For the discriminant analysis, the data were transformed in the same way as for the PCA analysis to improve the normality of the data. Each cue type was tested separately to establish whether the same cue type from different fish species could be distinguished from each other. The control group was also tested with each cue type. The percentages correctly predicted by the discriminant analysis are related to the degree of variation in the data. If a group has a large variation in the behaviour of the parasites, group membership is less likely to be predicted correctly.

Of the four different cue types, conditioned water was discriminated most effectively for each species with percentages correct for cod conditioned water, trout conditioned water and whiting conditioned water being 90%, 70% and 60%, respectively (Table 4.4). Mucus was least effectively discriminated overall, although the lowest percentage correct was for flounder flesh at 6.6%. Correct percentages for the control group were also low at 33%.

3.4. Fractal analysis

The highest track complexity was seen in the whiting conditioned water group (1.47 ± 0.18) and the lowest was in the flounder faeces group (1.11 ± 0.28) (Figure 4.14). The fractal dimension of the control group was 1.44 ± 0.18 . However, none of the groups were significantly different from each other due to the large variation within each group. Also, as the parasites were limited to a small area of the arena (the Y-shaped channel) their coverage of the arena, which is a component of track complexity, was also limited. r^2 for all the data was 0.98 ± 0.027 , indicating good accuracy of the fractal technique.

Table 4.4. Discriminant analysis correct percentages for each cue type. CON = control, WCW = whiting conditioned water, WM = whiting mucus, WF = whiting flesh, WFA = whiting faeces, CCW = cod conditioned water, CM = cod mucus, CF = cod flesh, CFA = cod faeces, FCW = flounder conditioned water, FM = flounder mucus, FF = flounder flesh, FFA = flounder faeces, TCW = trout conditioned water, TF = trout flesh, TM = trout mucus, TFA = trout faeces.

Cue	Percent correct	Cue	Percent correct
WCW	60	WM	16.6
CCW	90	CM	33.3
FCW	43.3	FM	23.3
TCW	70	TM	26.6
WF	60	WFA	46.6
CF	23.3	CFA	50
FF	6.6	FFA	50
TF	26.6	TFA	53.3
CON	33.3		

4. Discussion

This experiment provides some evidence that pre-metamorphosed adult female *Lernaeocera branchialis* exhibit a behavioural response to a variety of fish derived chemical cues. However, due to the great deal of variation in behaviour between individual parasites, the evidence is not conclusive. Some parasites remain virtually still for the duration of the experiment, while others swim rapidly, covering a great distance.

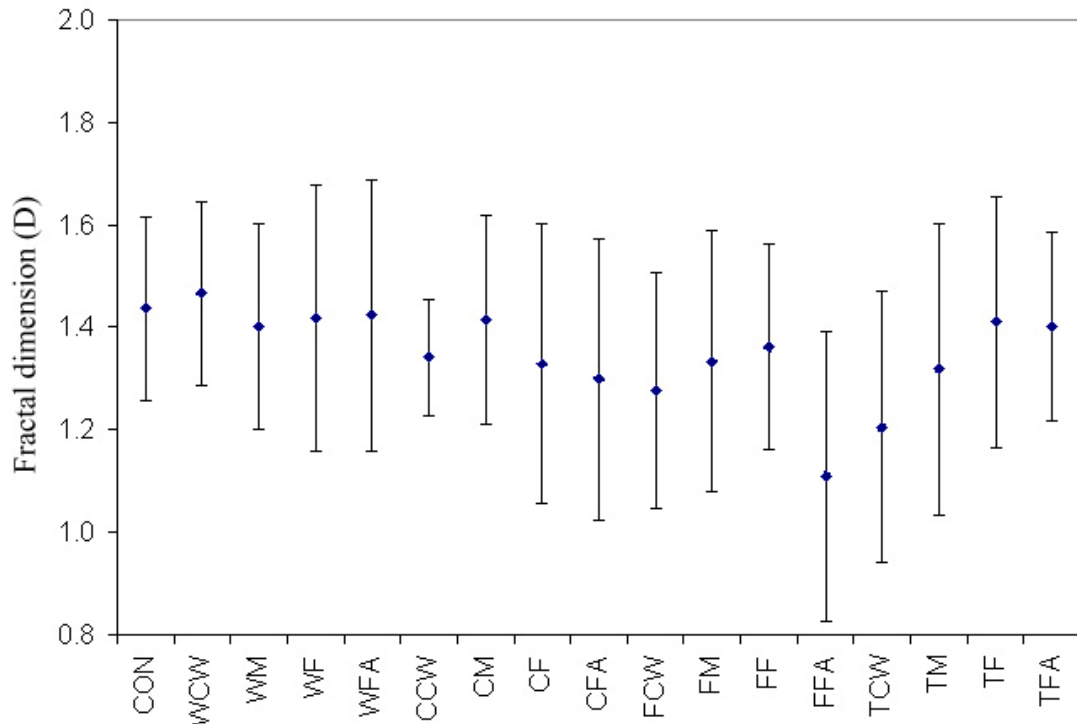

Figure 4.14. Fractal dimensions (D) for swimming paths of *L. branchialis* exposed to different chemical cue types. Bars show standard error. CON = control, WCW = whiting conditioned water, WM = whiting mucus, WF = whiting flesh, WFA = whiting faeces, CCW = cod conditioned water, CM = cod mucus, CF = cod flesh, CFA = cod faeces, FCW = flounder conditioned water, FM = flounder mucus, FF = flounder flesh, FFA = flounder faeces, TCW = trout conditioned water, TF = trout flesh, TM = trout mucus, TFA = trout faeces.

However, most parasites exhibited intermittent swimming with numerous swimming and immobile bouts. This, combined with the high degree of turning and meander, may be indicative of a parasite that is searching for a host, trying to cover as much water as possible and stopping regularly to “smell” the water for any sign of a fish host.

4.1. Behavioural responses

The behavioural responses of the parasites can be divided into three groups according to the type of cue: attraction, repulsion and no response. Parasite responses to some cues, particularly those from definitive hosts (whiting and cod) showed evidence of attraction to the cue. Conditioned water appeared to be the most attractive to the parasites, with whiting conditioned water being the most attractive of these. Although parasites exposed to whiting conditioned water did not spend significantly more time in the cue zone than the control parasites ($33.7 \pm 35.3\%$ (WCW) *vs.* $31.2 \pm 35.1\%$ (Con)), they did have a higher mean velocity (5.3 ± 2.0 mm/sec (WCW) *vs.* 4.0 ± 2.4 mm/sec (Con)), travelling further during the experiments (158.7 ± 60.7 cm (WCW) *vs.* 118.8 ± 72.8 cm (Con)) and also had a higher turn rate (161.5 ± 37.3 degrees/sec (WCW) *vs.* 130.1 ± 46.4 degrees/sec (Con)), indicating that they may have been excited by the presence of whiting derived compounds, triggering a behavioural response to cover an area more thoroughly to locate the cue source. Swimming bout analysis revealed that parasites exposed to whiting conditioned water had fewer swimming bouts than control parasites (5.3 ± 6.6 (WCW) *vs.* 13 ± 14.1 (Con)), although these bouts were longer (236.9 ± 111.0 secs (WCW) *vs.* 114.2 ± 127.2 seconds (Con)) and the parasites had a higher velocity (5.6 ± 1.9 mm/sec (WCW) *vs.* 4.7 ± 2.2 mm/sec (Con)) and travelled further in the swimming bouts (84.72 ± 77.2 cm (WCW) *vs.* 73.2 ± 91.6 cm (Con)), so consequently spent more time moving than control parasites (275.2 ± 54.5 seconds (WCW) *vs.* 234.9 ± 67.5 seconds (Con)). The PCA analysis also indicates that whiting conditioned water induces a response, as the whiting conditioned water data forms a distinct group and is not spread randomly as some of the other cues are (Figure 4.12).

As cod is also a definitive host, a similar response may be expected from parasites exposed to cod conditioned water. However, in this group the behavioural response was weaker, with only a higher turn rate (153.1 ± 24.3 degrees/sec (CCW) vs. 130.1 ± 46.4 degrees/sec (Con)) and more time spent moving (274.1 ± 35.2 (CCW) seconds vs. 234.9 ± 67.5 seconds (Con)) than controls indicating that the parasites may have been excited by cod conditioned water, although the PCA shows the cod conditioned water group forming a tighter group than the whiting conditioned water group and the discriminant analysis correctly predicted 90% of cod conditioned water replicates, indicating that the response to cod conditioned water is not random, but a specific pattern of behaviour, although showing a considerable degree of variation.

Despite the fact that an attraction response was seen from parasites exposed to definitive host conditioned water, little or no response was seen from parasites exposed to mucus. This suggests that cues that are exuded from fish into the water do not originate wholly or at all from the mucus, but from some other source. However, it is known that fish mucus is a potential source of chemical cues for both predators and parasites, and some of the cues that affect fish behaviour appear to originate from the skin (Lebedeva and Golovkina, 1994). Electrophysiological responses of the cnidocytes of the Portuguese man o' war, *Physalia physalis* L., showed that they react to fish mucus (Purcell and Anderson, 1995), and the cercariae of *Acanthostomum brauni* Maie Garson and Gill 1961 penetrate fish skin once they detect a particular component of the mucus (Denunez and Haas, 1991). Also, in choice chamber studies with *Lepeophtheirus salmonis*, a strong response was seen with salmon and turbot cues, such as conditioned water, mucus and flesh (Devine *et al.*, 2000). Given the evidence from other species and the suggested importance of fish mucus as a source of chemical cues, it is likely that it has a role to play in host location in *L. branchialis*.

The lack of response in *L. branchialis* to fish mucus may be a result of the collection method using ammonium bicarbonate, which may have denatured or otherwise affected the specific components of fish mucus that may be used in host location. Alternative methods of mucus collection, such as a cotton swab, require investigation to assess the response of *L. branchialis* to fish mucus.

Although an attraction response was seen from parasites exposed to definitive host cue sources, a stronger repulsion response was evident from parasites exposed to non-target species, especially trout. Flounder faeces and trout conditioned water were the most repulsive and parasites exposed to these cue sources spent significantly less time in the cue zone ($0.1 \pm 0.3\%$ (FF) and $4.5 \pm 11.5\%$ (TCW) vs. $31.1 \pm 35.1\%$ (Con)), had significantly lower mean velocity (1.2 ± 1.2 mm/sec (FF) and 1.8 ± 2.1 mm/sec (TCW) vs. 4.0 ± 2.4 mm/sec (Con)), maximum velocity (12.2 ± 11.1 mm/sec (FF) and 15.8 ± 9.8 mm/sec (TCW) vs. 20.4 ± 11.2 mm/sec (Con)) and turn rate (59.9 ± 38.7 degrees/sec (FF) and 62.4 ± 55.7 degrees/sec (TCW) vs. 130.1 ± 46.4 degrees/sec (Con)), travelled significantly less distance (36.5 ± 35.7 cm (FF) and 55.1 ± 63.2 cm (TCW) vs. 118.8 ± 72.8 cm (Con)) and spent significantly more time immobile (173.3 ± 68.1 secs (FF) and 184.3 ± 95.4 secs (TCW) vs. 64.1 ± 67.5 secs (Con)) than parasites from the control group. The PCA shows that some of the flounder and trout cue sources form groups distinctly separate from the definitive host and control groups (Figure 4.13b), while others do not form any particular grouping, which implies either a strong repulsive response or no response at all.

Some cue sources proved neither attractive nor repulsive to *L. branchialis* and little or no behavioural response was seen from parasites exposed to these cue sources. Of all the different cue sources, fish flesh from all species did not elicit any response and this is most evident from the PCA (Figure 4.12b) where the data is spread randomly and

does not form any distinct groups. Also, the discriminant analysis was unable to accurately predict group membership for most of the flesh groups with flounder flesh being the lowest with only 6.6% being predicted correctly.

4.2. Implications for host preference

Currently *L. branchialis* is viewed as a genetically homogenous population infecting a range of gadoids. However, the evidence of a differential behavioural response to whiting conditioned water and cod conditioned water suggests that cod and whiting are not treated in the same way by the parasite. It is interesting to note that at the field site where the parasites were collected, almost all whiting were infected with *L. branchialis*, whereas few infected cod were found (relative to numbers of uninfected cod). This evidence raises two alternative hypotheses: either that there are genetically determined sub-species or host preferences in *L. branchialis*, or that there is some form of environmental pre-conditioning, either maternally derived or at the egg / nauplius stages, that allows the parasite to preferentially recognise the host species from which it originated. Genetically determined sub-species have already been demonstrated in several other copepods. In *Caligus elongatus* analysis of the mtDNA gene CO1 has revealed two types of genetic lineages (Øines and Heuch, 2005). Analysis of the genetic structure of *Lepeophtheirus europaensis* Zeddam, 1988 has shown polymorphism between those parasitic on brill (*Scophthalmus rhombus* (L.)) and those on flounder (*Platichthys flesus* L.) (De Meeus *et al.*, 1992). This is attributed to salinity imparting a strong environmental selective pressure on *L. europaensis* parasitic on flounder in coastal lagoons. Although *L. europaensis* from brill may infect flounder during their reproductive migrations, the unstable salinities found in coastal lagoons will result in high mortality in these copepods. A similar differential preference for different fish hosts was also demonstrated in

Lepeophtheirus pectoralis (Müller, 1776) (Boxshall, 1976). Copepodids hatched from eggs of adults parasitic on plaice (*Pleuronectes platessa* L.), preferred plaice over all the other species tested, whereas copepodids hatched from eggs of adults parasitic on flounder (*Platichthys flesus* (L.)), preferred flounder over all the other species tested. This is attributed to separate strains of *L. pectoralis*, which preferentially parasitised the host from which they originated, if offered a choice, although they were still capable of infecting either host species.

To determine whether this process of sub-speciation is occurring in *L. branchialis* it was planned to repeat the choice chamber experiments with adult female *L. branchialis* originating from eggs of *L. branchialis* parasitic on cod, to determine whether these parasites would show a preference for cod derived cues instead of whiting derived cues. However, the intermediate host infection was unsuccessful and this experiment had to be abandoned. In another experiment, cod were successfully infected by *L. branchialis* parasitic on flounder which were likely to have originated from whiting (given that of all the cod found at the site, virtually none were infected with *L. branchialis*) and demonstrates that parasitism of cod is still possible, although they appear to prefer whiting. Given that the process of sub-speciation has been demonstrated in other parasitic copepods and that *L. branchialis* show a different behavioural response to whiting conditioned water and cod conditioned water, it is likely that this process is also occurring in *L. branchialis*, although the selective pressures which may drive this sub-speciation are uncertain at this stage.

4.3. Implications for host location

The first hypothesis in section 1 stating that pre-metamorphosed adult female *L. branchialis* will choose definitive host fish derived chemicals in the water over clean

sea water, cannot be proven to be true from the results of this experiment, as parasites did not choose to spend more time in the cue zone than the control zone when exposed to definitive host cues, although analysis of behaviour patterns has shown that parasites are excited by the presence of these cues. It is likely that there are other factors involved in host location in *L. branchialis*, which may explain the lack of preference when presented only with chemical cues. Physical cues may also play an important role, such as vibrations and flows from swimming fish e.g. Heuch and Karlsen (1997), Heuch *et al.* (2007), or the exhalent current from the fish's gills. Observations during the choice chamber experiments showed that parasites were often attracted to the inflow of water at the end of each arm of the choice chamber.

Sproston (1942) suggested that *L. branchialis* is not a strong swimmer. However, the results of this experiment suggest that *L. branchialis* has considerable swimming capabilities and may be able to cover moderate distances to locate a host. The mean distance covered by control parasites in five minutes was 118.77 cm, which equates to 14.25 m / hr and gives some idea of the mobility of the parasite and its host seeking ability. In comparison, distances covered by *L. salmonis* when excited by the presence of salmon conditioned water were 45.2 ± 8.3 cm for a three minute period, giving a velocity of 90.4 m / hr (Devine *et al.*, 2000). These figures suggest that *L. branchialis* can cover a moderate distance to locate a host. Whether physical phenomena, such as tidal currents, haloclines and thermoclines, are used during this phase, or location of the host's habitat is purely by chance is not known. However, considering the results of this experiment and the behaviour of other parasitic copepods, it is suggested that in *L. branchialis* physical cues are used to locate a definitive host within close range and once contact has been made, chemical cues are used to determine whether the host is the correct species for infection.

The results of this experiment and their implications for host preference and host location are discussed further in conjunction with the results of the 3D behaviour experiments in the following chapter.

4.4. Experiment limitations and future work

The age of the parasites used for the experiment is important as adult *L. branchialis* that have left the intermediate host in search of a definitive host do not feed and, therefore, must rely on energy reserves until they infect a new host and begin feeding once again. It is known that the adult female spends 3-8 days on the intermediate host, depending on the number of times it is inseminated (Anstensrud, 1990), and parasites used for this experiment had left the intermediate host within 1-2 days to ensure that they were utilised when they had maximum energy reserves, although it was not determined whether the infective potential of the parasites was highest as soon as they left the intermediate host, or if the host-seeking capabilities of the parasites increases over several days after leaving the intermediate host. The change in host-seeking performance over time after the parasites have left the intermediate host requires further investigation.

Collecting natural exudates from fish by holding them for a period is likely to artificially increase the concentrations above those that would occur naturally and may lead to compounds being repulsive to the parasites that would be attractive at lower concentrations. To provoke host seeking behaviour may require threshold levels of chemical cues (Doall *et al.*, 1998) and similarly a concentration above a certain threshold may suppress this behaviour. An attempt was made to test different concentrations of conditioned water by keeping the fish in the water for different lengths of time, although a qualitative assessment of the parasites' behaviour when

presented with different concentrations of conditioned water suggested that this did not affect the parasites' responses. Other factors such as the age and size of the fish, sex and state of sexual maturity may also have a bearing on the results as these may affect the concentrations and type of compounds released by the fish. *L. branchialis* may prefer hosts of a particular size, sex or state of sexual maturity, although this was not investigated. The PCA graphs showed that there were several outliers in all the groups and these may have been the result of one or several of these factors that were not assessed in this experiment. By controlling these factors there may have been less variability in the data, resulting in more significance between the different cue sources.

The specific compounds in conditioned water that attract *L. branchialis* to its host have not yet been established, although in other species a great diversity of different attractant compounds have been found. However, structure-function studies have shown that neutral amino acid compounds with a basic carboxyl terminal are commonly used in marine organisms for modifying physiological and behavioural responses (Rittschof and Cohen, 2004). In *Diplostomum spathaceum* (Rudolphi, 1819) a number of small molecular weight compounds derived from fish skin and mucus produce an attraction response (Haas *et al.*, 2002). Gas chromatography and mass spectrometry have been used successfully to extract specific compounds from salmon conditioned water (SCW) and a number of small molecules have been identified which may play a role in host location in *L. salmonis* (Ingvarsdottir *et al.*, 2002b). Both isophorone and 1-octen-3-ol (low molecular weight components of fish odour) caused activation responses from the lice and induced electrophysiological responses from the antennae. Similar extraction techniques with whiting and cod conditioned

water may be used to determine the specific compounds that elicit an attraction response in *L. branchialis*.

The choice chamber experiment was designed to provide *L. branchialis* with a simple choice and determine preferences for fish derived chemical cues. However, the results of the experiment have shown that parasites often do not make this choice and that in fact behavioural responses are more subtle involving changes in velocity and turn rates for example. The choice chamber was not designed to allow parasites to freely exhibit this behaviour, as it is shallow and narrow, and they will often come into contact with the sides of the chamber. This problem was also noted by Devine *et al.* (2000), where *L. salmonis* were restricted to a choice chamber and demonstrated “edging” behaviour instead of the natural sinking and swimming behaviour shown by Hull *et al.* (1998). To accurately quantify parasite behaviour would require a larger chamber and analysis of three-dimensional data to give a true picture of natural parasite movements within the water column and these were the experimental aims that are discussed in the next chapter.

Chapter 5 – Parasite behaviour and host location in *Lernaeocera branchialis*: 3D tracking experiments

1. Introduction

In the previous chapter the host location behaviour of pre-metamorphosed adult female *Lernaeocera branchialis* was investigated using a choice chamber and several potential chemical cue sources to induce a behavioural response. Although a positive response to definite host cues was observed the data was not conclusive; the movements of the parasites were confined to a shallow, narrow channel so their behavioural response was limited and they were only tracked in two dimensions. Also, individual parasites often behaved very differently to each other, making it difficult to identify patterns in parasite behaviour that were a response to the chemical cues. In this second experiment, a larger arena was constructed to allow parasites to express their behaviour more naturally and their movements were tracked in three dimensions. The behaviour of individual parasites was recorded before and after a chemical cue source was added to account for the natural variability in the behaviour of individual parasites.

The purpose of this experiment was to identify changes in the parasite's behaviour when presented with potential chemical cue sources derived from host and non-host fish species. As the tools had been developed in the Paratrack software to characterise and quantify the behaviour of the parasites, it was possible to develop beyond a simple choice experiment. Two hypotheses were generated which were tested using the 3D arena:

1. Adult female *L. branchialis* will be excited by the presence of definitive host fish derived chemicals in the water and will show a different behavioural response compared to their behaviour in clean sea water.
2. Chemicals from other fish species, including non-target species and intermediate host species, will elicit little or no differential response in *L. branchialis* compared to their behaviour in clean sea water.

2. Materials and methods

2.1. Equipment design and setup

The 3D arena was constructed from 0.5mm thick clear acrylic and consisted of two equally sized chambers separated by a piece of acrylic (Figure 5.1). In the left chamber a mirror was set at an angle of 45°. This allowed the three-dimensional movements of the parasite to be observed using one video camera positioned above the arena and using the mirror to view the parasite in the z-plane (Chrásková *et al.*, 1999). Both chambers of the arena were filled with water to prevent diffraction of the image passing from the arena to the mirror. The outside of the arena was spray

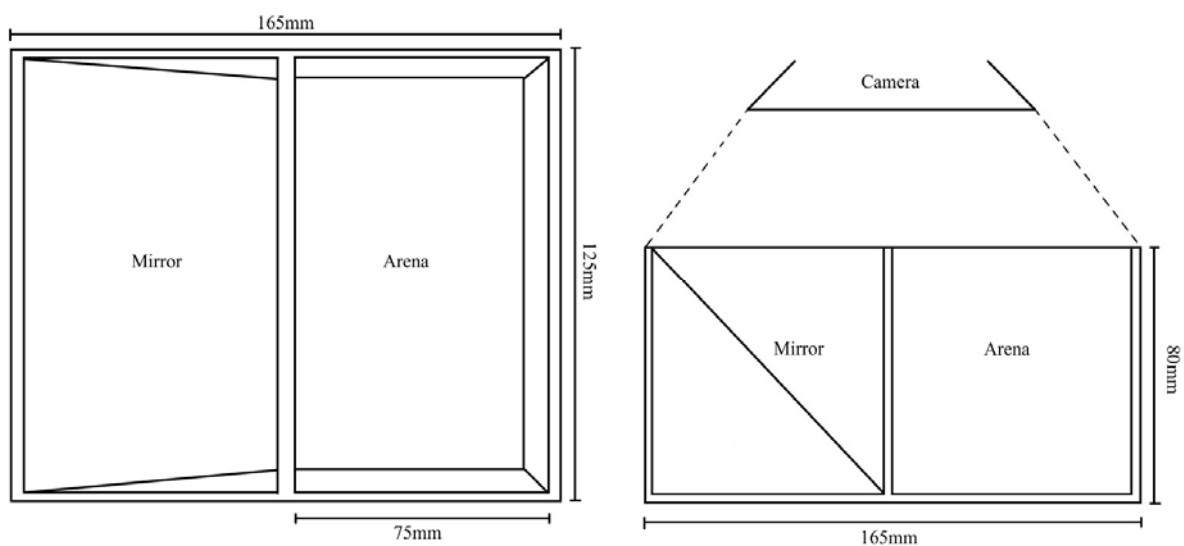

Figure 5.1. Schematic diagram of the 3D behaviour arena.

painted white to provide a contrasting background to allow the parasite to be detected easily. The arena was set up in the same way as in the choice chamber experiments, with the video camera positioned above the arena, and the light diffuser and four 12W lights surrounding the arena. The camera was connected to a pc via an s-video cable and videos were captured using Adobe Premier software version 7.0 Columbo (Adobe Systems Inc.) at a resolution of 720 x 576 pixels and a frame rate of 5 frames per second, then stored on the pc hard drive in avi format.

2.2. Experiment design

Flounder infected with *L. branchialis* were collected and the parasites were removed according to the methods described in Chapter 2. In the previous chapter, a positive response from the parasites was observed only using fish conditioned water. Therefore, the decision was made in this experiment to use only fish conditioned water as a potential chemical cue source. The same fish species were used, whiting, cod, flounder and trout and the conditioned water was prepared as described in Chapter 2.

For each experiment an adult female *L. branchialis* was introduced into the arena containing clean sea water at 10°C. After a short acclimatisation period of 2-3 minutes the movements of the parasite were recorded for three minutes with the video camera. The water was then siphoned from the arena leaving the parasite in approximately 1cm depth of water before the arena was then topped up with fish conditioned water. After another acclimatisation period of 2-3 minutes, the movements of the parasite were recorded again for a further three minutes. Twenty replicates were recorded for each type of conditioned water and in control water, giving a total of 200 replicates.

Once all the videos had been recorded, the path of movement made by each parasite was extracted using Paratrack as described in Chapter 2 and the behaviour parameters and fractal dimensions were calculated.

Upon initial inspection of the data, there appeared to be a contamination effect within some of the different cue sources. The fractal dimensions showed increased track complexity for whiting conditioned water, as may be expected following the results and conclusions of the choice chamber experiments in Chapter 4. However, the fractal dimensions for the corresponding control experiments for the same parasites showed an elevated track complexity, above that of the other control experiments for the other cue types. Therefore, the decision was made to repeat the whiting conditioned water experiments, but this time thoroughly cleaning the arena with Decon (~1g dry Decon in 500ml water) and flushing with water after each whiting conditioned water experiment to prevent the subsequent control experiment being contaminated.

2.3. Statistical analysis

The behavioural parameters for each pair of replicates, before and after the chemical cue was added, were compared using a Wilcoxon matched pairs test. The data were also analysed with Principal Component Analysis (PCA), using the difference between the control and chemical cue for each replicate. The fractal dimensions were analysed using a repeated measures GLM ANOVA with a Tukey *post-hoc* test. To identify any possible effects of contamination of the control experiments by the cue source experiments each set of control data for each cue source (20 replicates) was divided into four groups. These groups were then included as a grouping factor in a General Linear Model (GLM) with a Tukey *post-hoc* test, which was performed

separately for each individual behaviour parameter. Before the data was analysed using GLM, it was log transformed to normalise it.

3. Results

3.1. Analysis of replicate effects

The results of the GLM grouped to according the replicate number show evidence of different parasite behaviour with increasing replicate number (Figure 5.2). For the control and the whiting conditioned water experiments, the control data for the first ten replicates are distinctly separate from the second ten replicates for several of the behaviour parameters (average velocity, distance travelled, time spent moving, time spent immobile, velocity of swimming bouts, average time of immobile bouts and turn rate) (Figure 5.2a, 5.2c). However, none of these differences between replicates were significant. For the other cues (cod, flounder and trout conditioned water) the behaviour parameters grouped together, except for a few outlying values. In comparison, the repeated whiting conditioned water experiments grouped together as one group regardless of replicate number (Figure 5.2b, 5.2d). As the repeated whiting conditioned water data appears to be unaffected by replicate number, the decision was made to use it in the rest of the analyses, even though these experiments followed a slightly different protocol to the original experiments i.e. decon rinse after each chemical cue experiment.

3.2. Comparison with controls

The control data before and after the water was replaced in the arena were grouped together and averaged to establish normal behaviour for adult female *L. branchialis*.

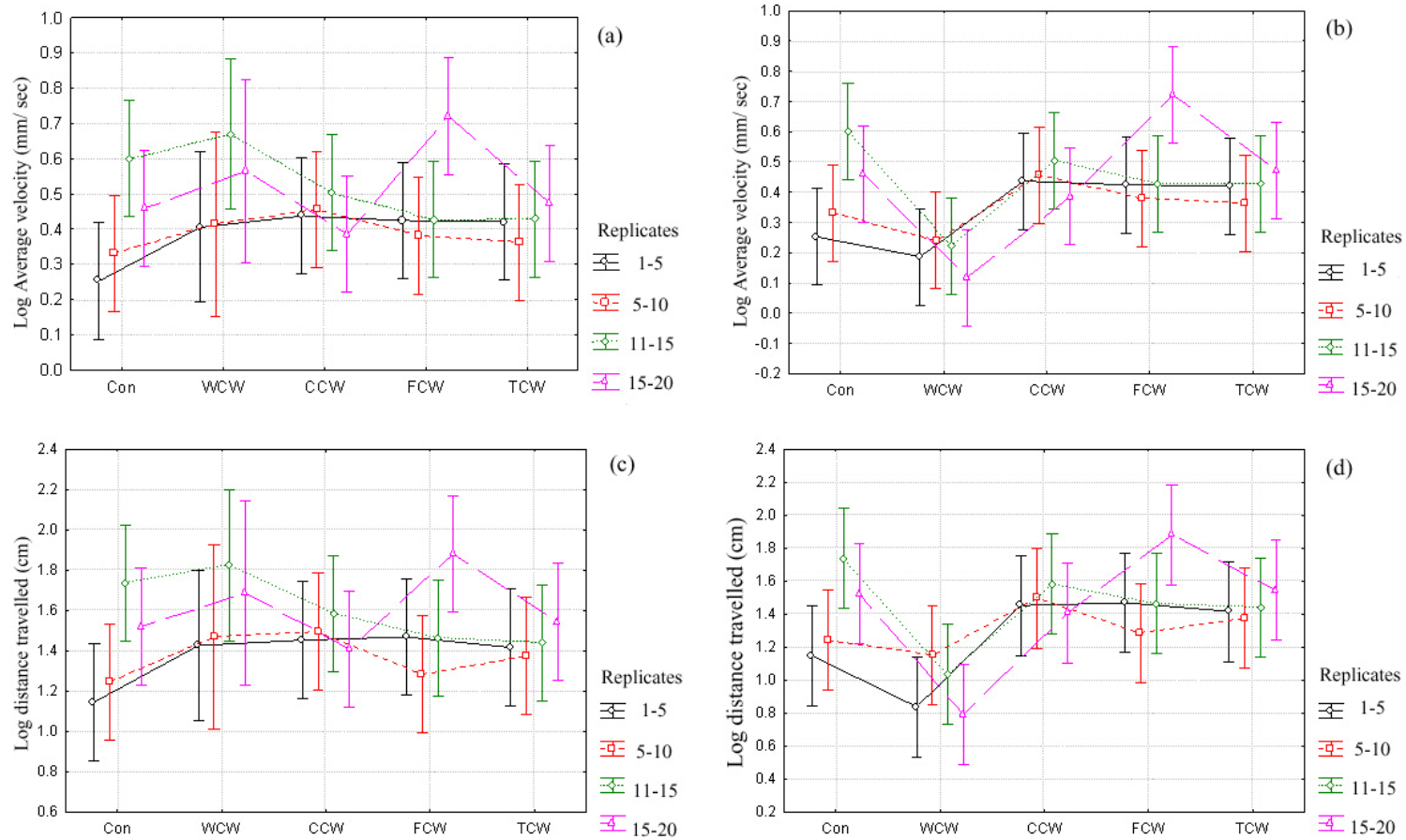

Figure 5.2. GLM means \pm standard deviation for 3D behaviour parameter control data divided into four replicate sets. (a) Average velocity (original data); (b) average velocity (repeated whiting conditioned water data with decon rinse); (c) distance travelled (original data); and (d) distance travelled (repeated whiting conditioned water data with decon rinse). Abbreviations: Con = control, WCW = whiting conditioned water, CCW = cod conditioned water, FCW = flounder conditioned water, TCW = trout conditioned water.

The parasites swam on average 31.1 ± 23.4 cm in 3 minutes with a mean and maximum velocity of 1.74 ± 1.31 cm s⁻¹ and 9.76 ± 9.04 cm s⁻¹, respectively. They spent 80% of the time moving and had an average of 5.95 ± 5.74 swim bouts (~2 per minute), which meant that the average time of each swimming bout was longer than the average time of each immobile bout. They exhibited a high level of turning with an average turn rate of 71.62 ± 46.7 degrees sec⁻¹ and meander of 43.07 ± 19.2 degrees mm⁻¹. This high degree of turning resulted in some complex paths and an average fractal dimension of 1.38 ± 0.31 (1.0 = straight line, 2.0 = Brownian motion). Observations during the experiments showed that the parasites spent a considerable portion of the time on the bottom of the arena, either swimming or immobile, although this was not quantified. Of the four cue types tested, whiting and trout conditioned water produced the most significant differences in parasite behaviour compared to their associated controls. In the control group, parasite behaviour in the first half of each experiment was very similar to behaviour in the second half. As there is a high level of variability in the data, many of the differences in behaviour between the control and cues are not significant. In general, the whiting conditioned water group did not show a greater response than the other cue groups, although the control parameters for the repeated whiting conditioned water were generally lower than the other groups, meaning that more of their responses were significant.

Parasites showed a significant increase in average velocity compared to the controls when exposed to whiting and trout conditioned water ($P < 0.01$) (Figure 5.3a). However, these cues did not elicit a significant increase in maximum velocity, although parasites exposed to cod and flounder conditioned water showed a decrease

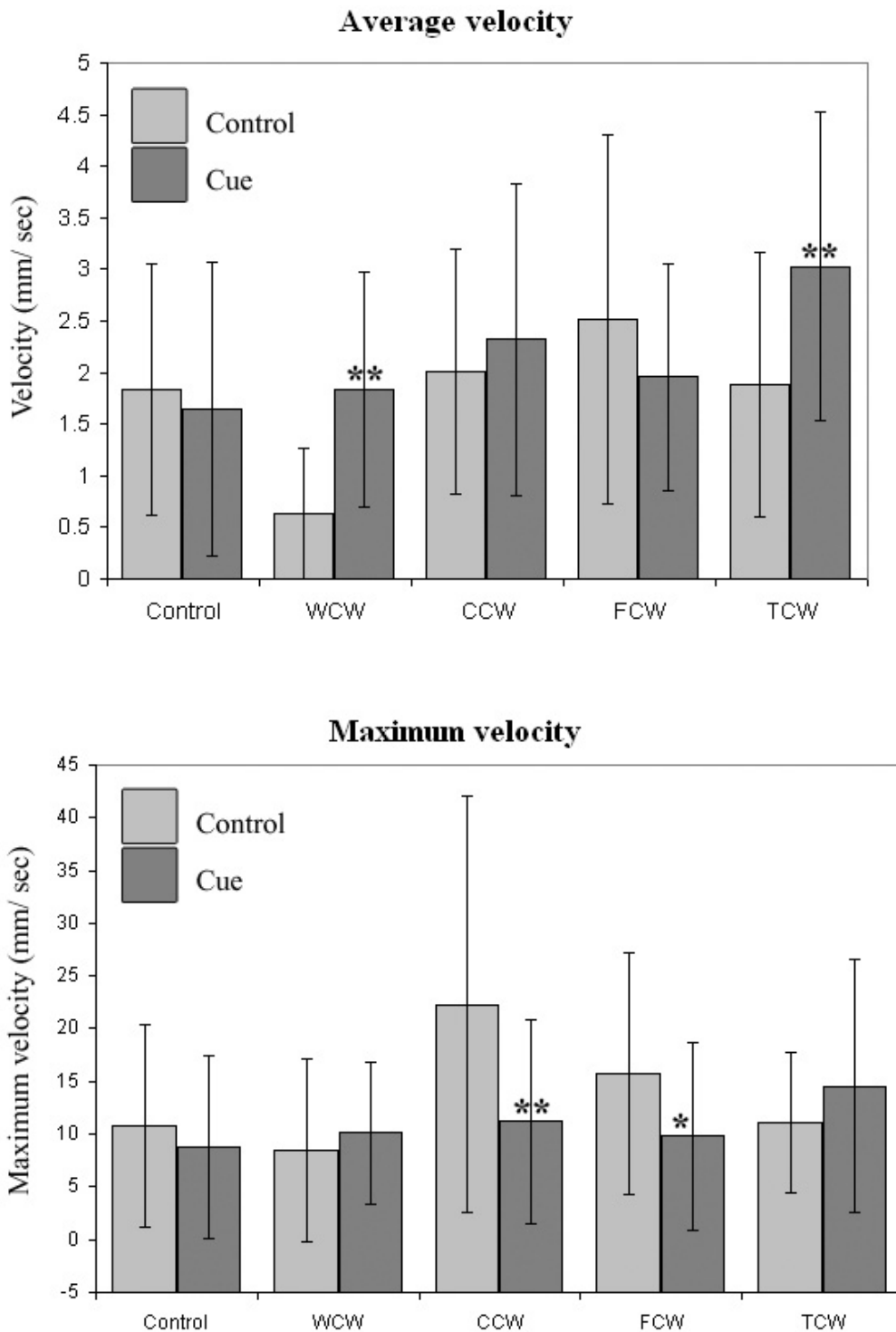

Figure 5.3. Comparison with control of velocities of *L. branchialis* for each chemical cue. Bars show standard deviation. Significance: * = $P < 0.05$, ** = $P < 0.01$. WCW = whiting conditioned water, CCW = cod conditioned water, FCW = flounder conditioned water, TCW = trout conditioned water.

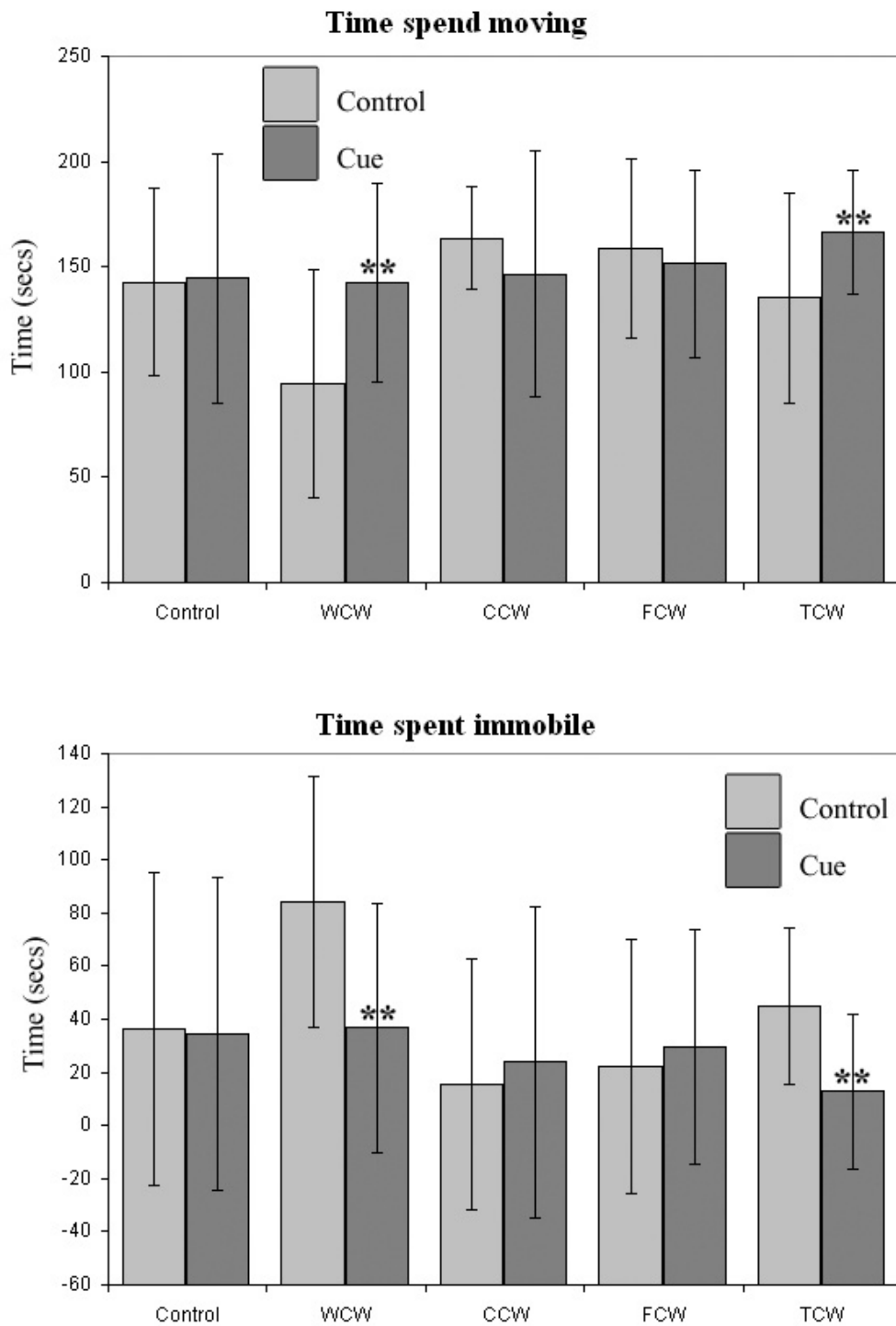

Figure 5.4. Comparison with control of activity of *L. branchialis* for each chemical cue. Bars show standard deviation. Significance: * = $P < 0.05$, ** = $P < 0.01$. WCW = whiting conditioned water, CCW = cod conditioned water, FCW = flounder conditioned water, TCW = trout conditioned water.

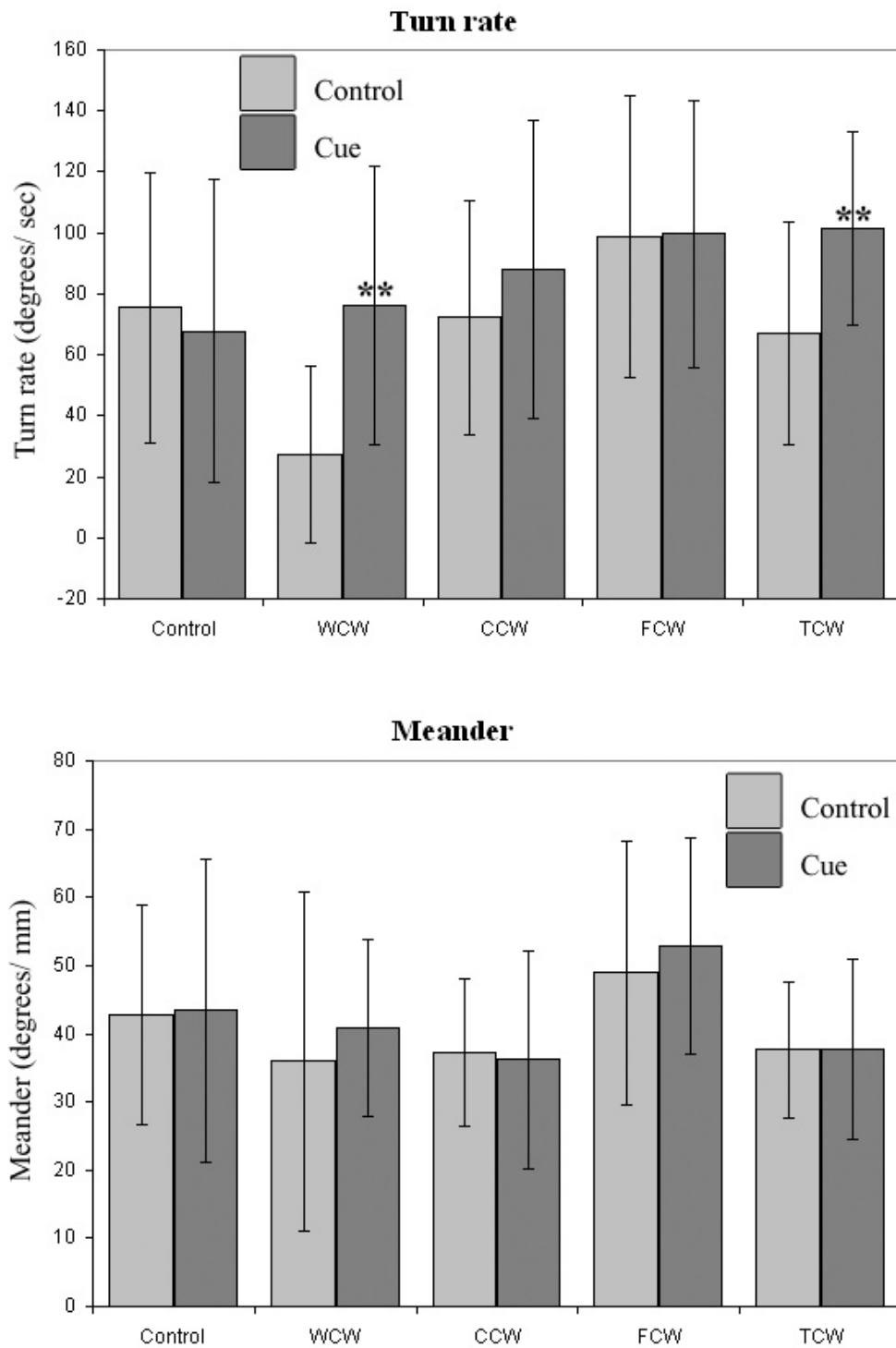

Figure 5.5. Comparison with control of path shape of *L. branchialis* for each chemical cue. Bars show standard deviation. Significance: ** = $P < 0.01$. WCW = whiting conditioned water, CCW = cod conditioned water, FCW = flounder conditioned water, TCW = trout conditioned water.

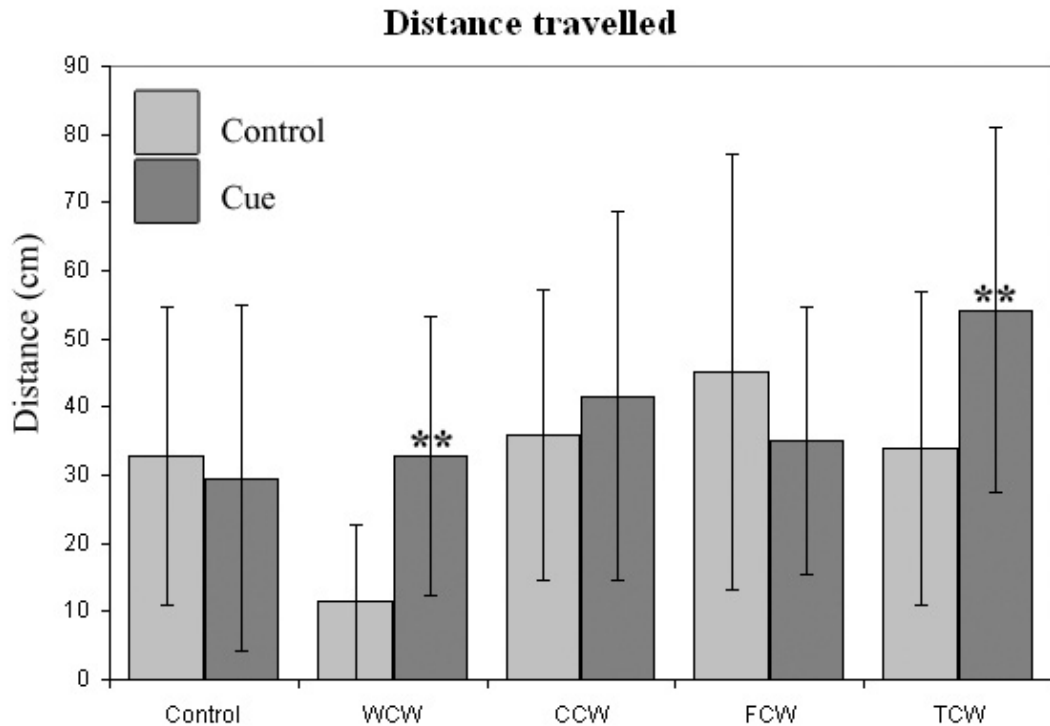

Figure 5.6. Comparison with control of distance travelled by *L. branchialis* for each chemical cue. Bars show standard deviation. Significance: ** = $P < 0.01$. WCW = whiting conditioned water, CCW = cod conditioned water, FCW = flounder conditioned water, TCW = trout conditioned water.

in maximum velocity compared to the controls ($P < 0.01$ and $P < 0.05$ respectively). Parasites exposed to both whiting and trout conditioned water showed a significant increase in distance travelled, time spent moving and a decrease in time spent immobile, compared to their corresponding controls ($P < 0.01$) (Figure 5.4 & Figure 5.6). None of the other cues were significant for these parameters. Turn rate was also greater for the whiting and trout conditioned water groups ($P < 0.01$) although meander was not significantly different from the controls for any of the cues (Figure 5.5).

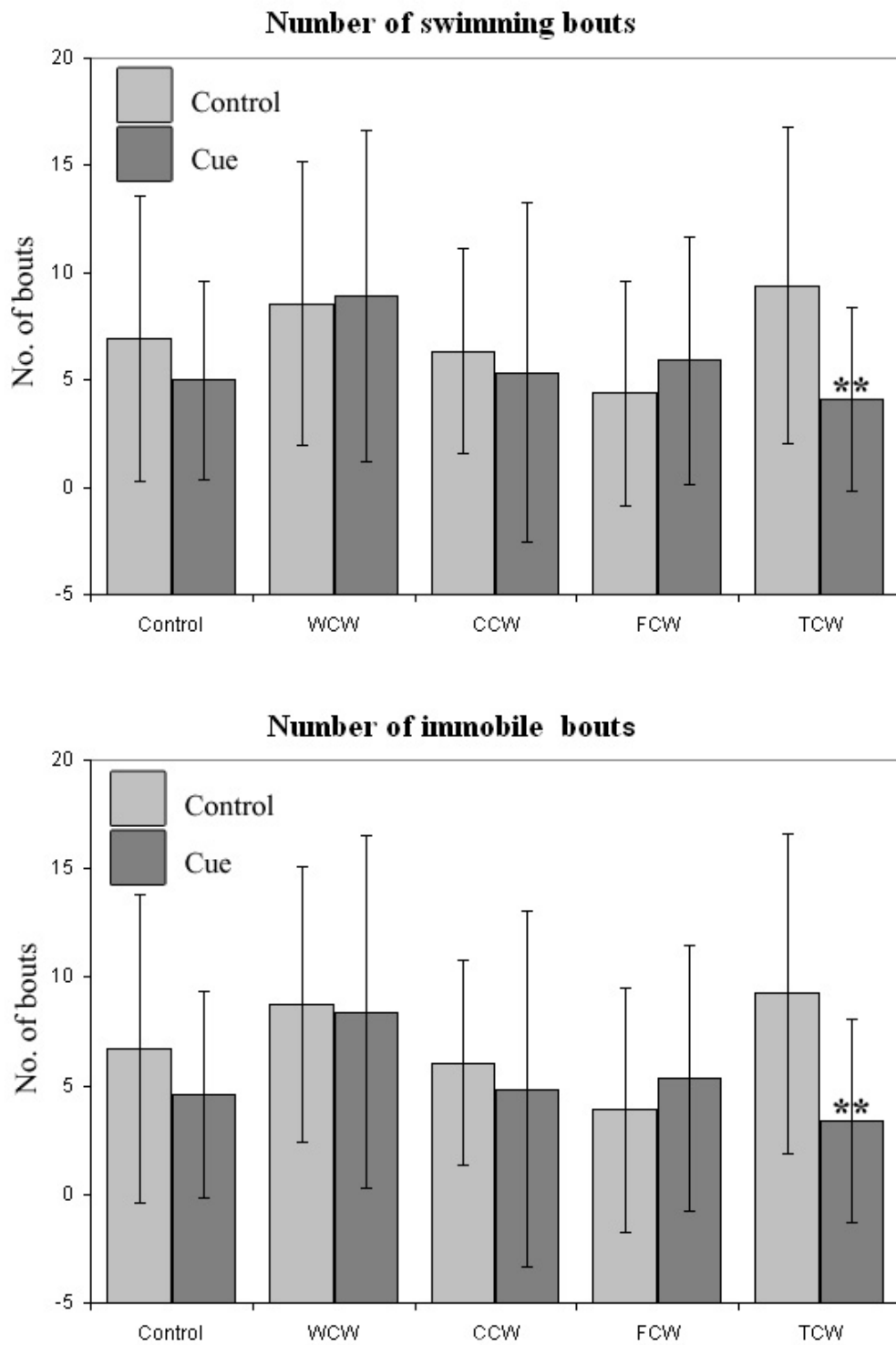

Figure 5.7. Comparison with control of number of bouts in *L. branchialis* for each chemical cue. Bars show standard deviation. Significance: ** = $P < 0.01$. WCW = whiting conditioned water, CCW = cod conditioned water, FCW = flounder conditioned water, TCW = trout conditioned water.

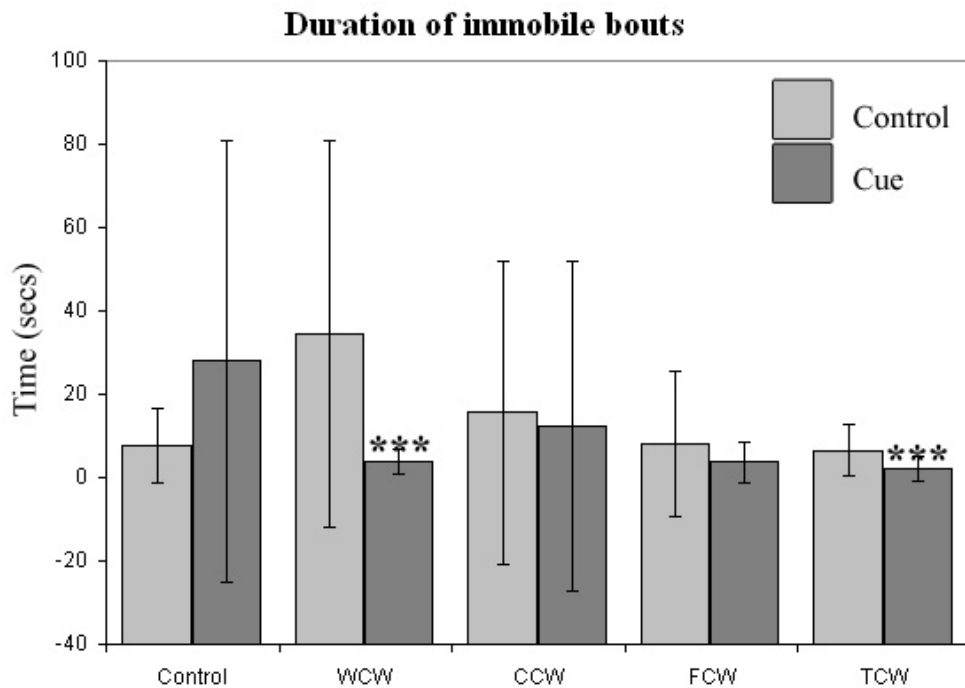
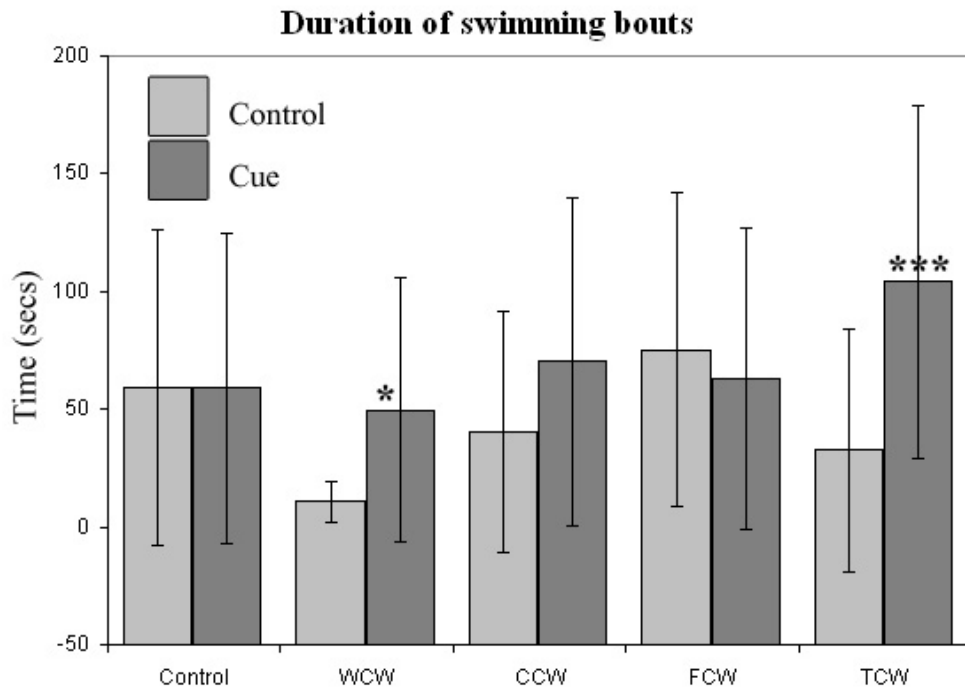

Figure 5.8. Comparison with control of bout duration of *L. branchialis* for each chemical cue. Bars show standard deviation. Significance: * = $P < 0.05$, *** = $P < 0.001$. WCW = whiting conditioned water, CCW = cod conditioned water, FCW = flounder conditioned water, TCW = trout conditioned water.

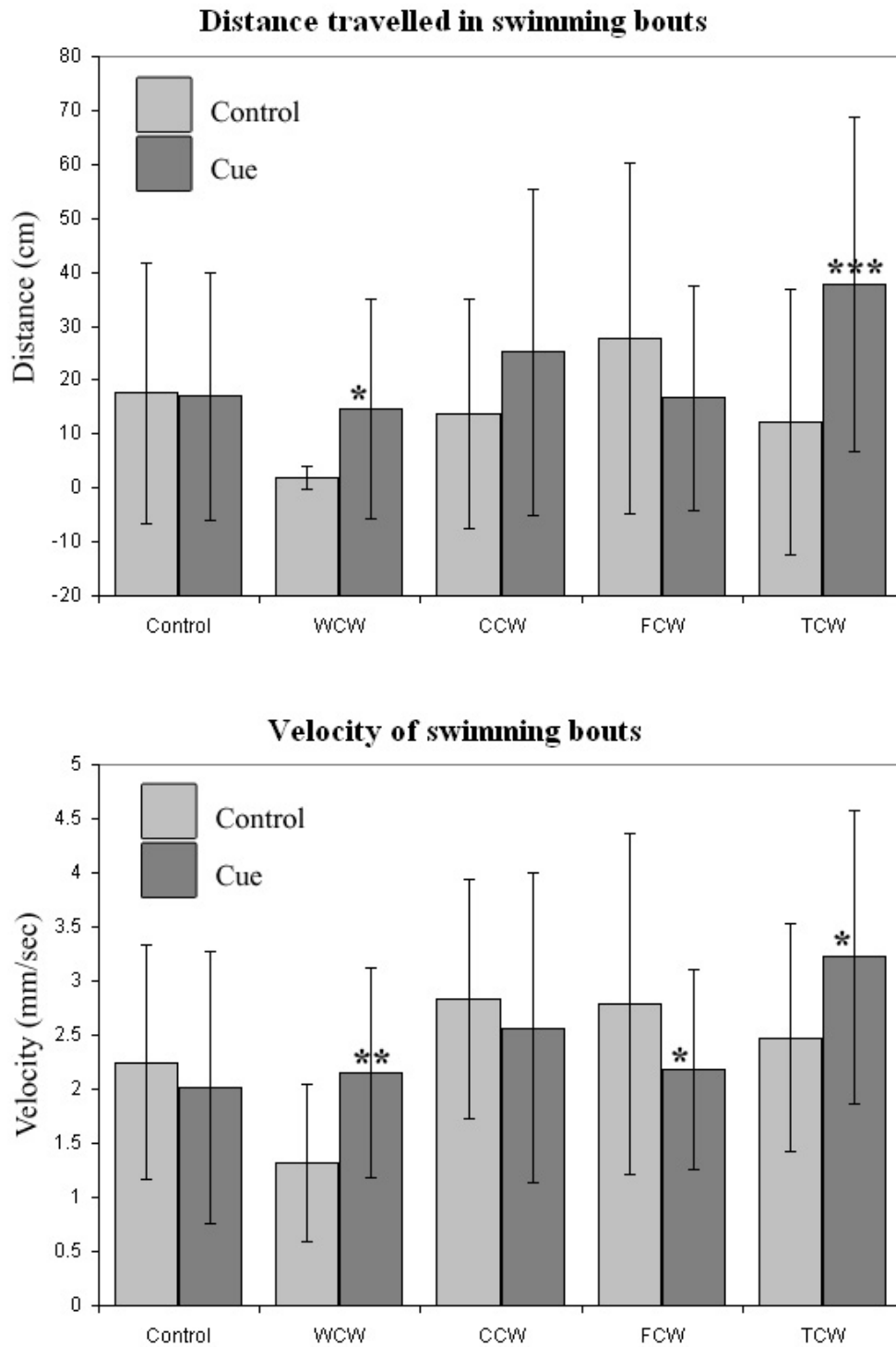

Figure 5.9. Comparison with control of distance travelled and velocity in swim bouts of *L. branchialis* for each chemical cue. Bars show standard deviation. Significance: * = $P < 0.05$, ** = $P < 0.01$, *** = $P < 0.001$. WCW = whiting conditioned water, CCW = cod conditioned water, FCW = flounder conditioned water, TCW = trout conditioned water.

The trout conditioned water group had fewer swimming and immobile bouts than the controls ($P < 0.01$) (Figure 5.7), and the duration of these swimming bouts was longer ($P < 0.001$), although the duration of the immobile bouts was shorter ($P < 0.001$) (Figure 5.8). They also travelled further than the controls ($P < 0.001$) and had a higher velocity ($P < 0.05$) (Figure 5.9). In comparison, the number of swimming and immobile bouts for the whiting conditioned water group was very similar to the controls (Figure 5.7), although the duration of the swimming bouts was longer ($P < 0.05$) and that of the immobile bouts was shorter ($P < 0.001$) (Figure 5.8). Also, the distance travelled in swimming bouts was greater ($P < 0.05$) and the velocity was higher ($P < 0.01$) compared to the controls (Figure 5.9). For the other cue types and the control group, none of the swimming and immobile bout parameters were significantly different from the controls, except the velocity of swimming bouts which was significantly lower for the flounder conditioned water group compared to the controls ($P < 0.05$) (Figure 5.9).

3.3. Principal Component Analysis

Before the data were entered into a PCA it was checked for normality. As all the parameters were approximately normal the data were not transformed prior to PCA. In an attempt to determine which behaviour parameters would not provide a positive contribution to the PCA by helping to separate the data, the correlation between all behaviour parameters were checked (Pearson correlation co-efficient) to determine which were similar to each other. The parameters that were most closely correlated were removed from the PCA analysis. Those removed were the velocity of swimming bouts, the number of immobile bouts and the time spent immobile.

Calculation of eigenvalues showed that the first three factors accounted for 47.01%, 22.86% and 10.60% of the variation between replicates. Although the first two factors accounted for 69.87% of the variation, the groups were not effectively separated by the PCA. Most of the whiting conditioned water data were grouped on the left of the graph and most of the flounder conditioned water data on the right, although there were several outlying values. The control data were predominantly grouped with the flounder data and the cod conditioned water data were spread over the whole area delimited by the other groups.

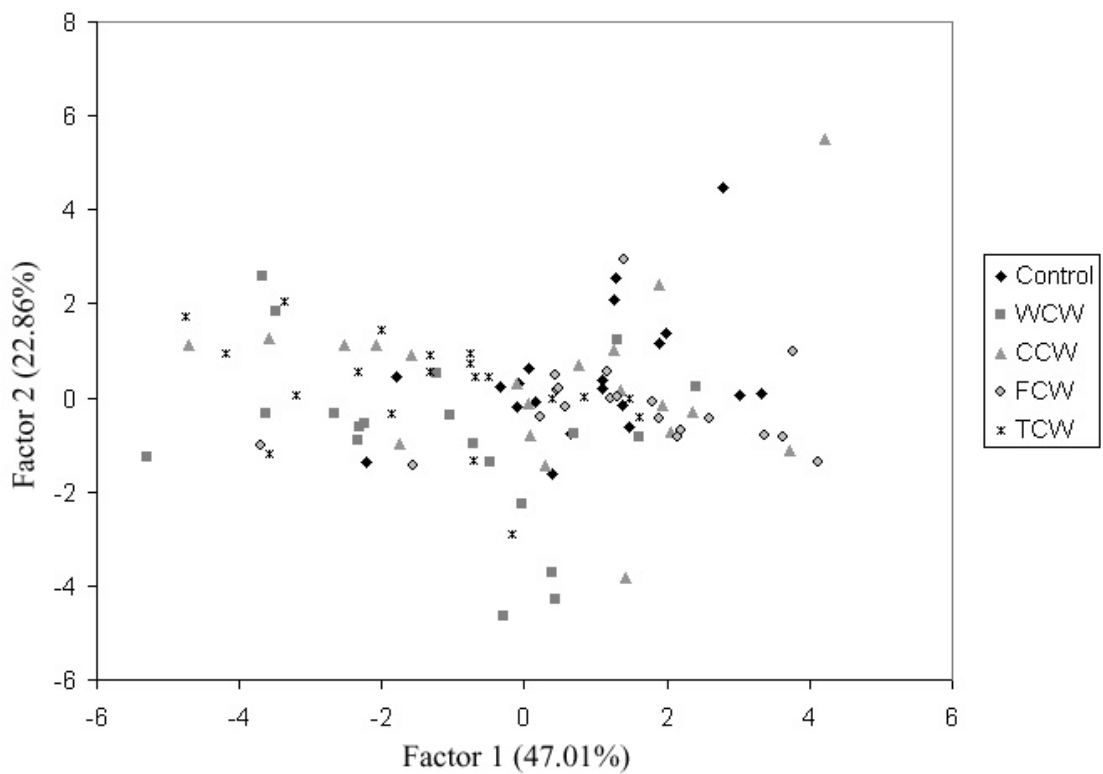

Figure 5.10. PCA of the 3D behaviour parameters of *L. branchialis*, using the difference between the control and cue for each replicate.

3.4. Fractal dimensions

The fractal dimensions for all the cue groups were higher than all the corresponding control groups (Figure 5.11). However, they were only significantly different for whiting conditioned water (1.04 ± 0.30 (WCW) vs. 1.58 ± 0.38 (Con), $P < 0.001$) and trout conditioned water (1.37 ± 0.23 (TCW) vs. 1.63 ± 0.23 (Con), $P < 0.05$). The whiting conditioned water control group was significantly different from all the other groups, but there were no other significant differences between groups. r^2 for all the data was 0.98 ± 0.032 , which indicates good accuracy of the technique.

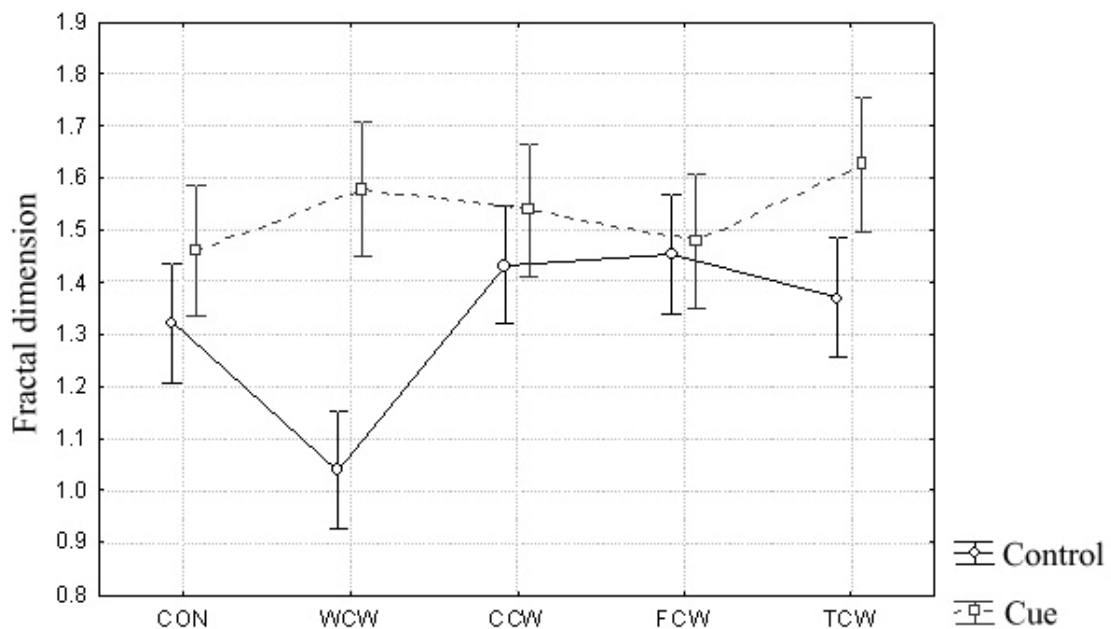

Figure 5.11. Fractal dimension means \pm standard deviation for each corresponding control and cue group.

4. Discussion

This experiment was designed to observe and quantify the natural behaviour of adult female *Lernaeocera branchialis* in clean sea water and in response to fish derived chemical cues from a variety of target host and non-target host species. In general, the behaviour of individual parasites was extremely varied, which made it difficult to

establish patterns in behaviour. However, differential behavioural responses were identified for some of the host derived cues.

4.1. Behavioural responses

The behaviour of *L. branchialis* is largely dependent on the habits of its fish hosts, as their behaviour is adapted to increase the likelihood of an encounter with a suitable host. The normal behaviour of *L. branchialis* is indicative of a parasite searching for a demersal host fish. A large proportion of their time was spent swimming or immobile on the bottom and they swam up into the water column only for brief periods or not at all. They spent the majority of their time swimming and exhibited a high degree of turning, allowing them to cover an area thoroughly and improve their chance of encountering a host. This high track sinuosity as searching behaviour has also been demonstrated in other copepod species such as *Temora longicornis* (Müller, 1785) where males swim along more sinuous routes than females to increase the chance of encounter with a mate (Doall *et al.*, 1998).

In comparison to the behaviour of *L. branchialis*, which predominantly remains on the bottom, *L. salmonis* parasitises migratory salmonids, which utilise different depths in the water column. Consequently, the behaviour of *L. salmonis* is adapted to increase the chance of encounter with their hosts. Copepodids of *L. salmonis* undergo a diel vertical migration, moving to the surface during the day and deeper water at night (Heuch *et al.*, 1995). As Atlantic salmon (*Salmo salar*) frequent surface waters at night and occupy deeper water during the day (Holm *et al.*, 1982; Westerberg, 1982; Doving *et al.*, 1985; Dutil and Coutu, 1988), they cross over as *L. salmonis* copepodids migrate upwards and salmon move downwards at dawn, allowing infection to take place. Since the flatfish intermediate hosts of *L. branchialis* are

benthic and the definite hosts are frequently demersal, they have no need to migrate upwards in the water column and this is reflected in their behaviour patterns. Although the arena used in this experiment was only 8cm deep, the parasites spent the majority of their time in the bottom quarter of the arena. Unlike Atlantic salmon, which are only exposed to *L. salmonis* for brief periods during their migrations in the water column, the hosts of *L. branchialis* are continually exposed to the parasite, which may contribute to the high prevalence of infection seen in some areas.

With the addition of fish conditioned water into the arena some of the behavioural patterns of *L. branchialis* were exaggerated; velocity increased and they spent more time moving, which in turn meant that they travelled further and turn rate increased, producing more complex tracks. This increased turn rate allows them to explore an area more efficiently where a host has been detected, and the increased velocity and movement increase the chance of encountering the host. It was induced by whiting conditioned water, as may be expected considering the results of the previous chapter, but also by trout conditioned water. However, the response to trout conditioned water was not as strong as the response to whiting conditioned water. A similar response to chemical cues has been observed in other copepods and may be likened to the frequent turning of insects moving upwind in an odour plume (Murlis *et al.*, 1992). In *L. salmonis* copepodids were seen to increase their speed and change direction frequently (Devine *et al.* 2000) in the presence of chemical cues in the water derived from Atlantic salmon. Males of *T. longicornis* exhibit increased speeds and a zig-zag track with sharp turns when chemical cues from a female are detected (Van Duren and Videler, 1995,1996; Doall *et al.*, 1998). A similar pattern is seen in *Oithona davisae* Ferrari & Orsi, 1984 where males swim in spirals of decreasing diameter as they approach females (Uchima and Murano, 1988). In *Leptodiatomus*

ashlandi (Marsh, 1893) fractal dimensions of males increased in the presence of females, increasing their chance of encountering a female (Uttieri *et al.*, 2007).

The change in behaviour of *L. branchialis* in the presence of host derived chemical cues demonstrated here is not without costs or risks. The increase in velocity consumes energy reserves at a faster rate, as well as increasing the chance of encounter with a predator and the high turn rates may make the parasites more attractive to predators such as fish (Tiselius and Jonsson, 1990; Doall *et al.*, 1998).

The change in parasite behaviour in response to cod conditioned water was similar to that for whiting conditioned water. However, as their response to cod conditioned water was weak none of the behavioural parameters were significantly different to the control behaviour, due to the large variation in the behaviour of individual parasites. In fact the only significant difference seen in the cod conditioned water group was a decrease in the maximum velocity. In the flounder conditioned water group the behavioural responses were opposite to the other three groups; average velocity decreased and they spent less time moving, which meant they travelled less distance. Although none of these responses were significant it may indicate a weak repulsive response to flounder conditioned water.

4.2. Experimental error

As the whiting conditioned water experiments were repeated using a slightly different protocol, care should be taken when directly comparing the whiting conditioned water group with other groups. Analysis of the original data showed that the whiting conditioned water control group was affected by the whiting conditioned water, producing an accumulative contamination effect with increasing replicate number, even though the arena was flushed thoroughly between replicates. This was

evident in the original fractal dimension data, where the track complexity of the whiting conditioned water control group was higher than that of the other control groups. Ideally all of the chemical cue groups would have been repeated, but this was not possible due to time limitations as it would have involved several months work. As only contamination of the whiting conditioned water control group appeared to have affected parasite behaviour, only this group was repeated, but with a decon rinse followed by a thorough flushing with water between replicates to prevent contamination.

Upon examination of the results the repeated whiting conditioned water group showed differences before and after the cue was added, but when compared to the other groups the whiting conditioned water control group was less active and the tracks were less complex than the other control groups. Also, the activity and track complexity of the whiting conditioned water group after the cue was added was similar to that of the other cue groups. This may be explained by the timing of the experiments. All the original experiments were undertaken in winter 2005 / 2006. However, the repeated whiting conditioned water experiments were completed in winter 2006 / 2007 and due to annual differences in the parasite populations as a result of factors such as weather conditions and water temperature, they may have been less active for the repeated whiting conditioned water experiments. Although the behaviour of the parasites in the repeated whiting conditioned water group cannot be directly compared to the other groups due to the reduced activity of this batch of parasites, the decision was made to use this data in the final results, as the primary objective of the experiment was to demonstrate a change in behaviour with the addition of chemical cues, and not to compare the behaviour of *L. branchialis* when exposed to chemical cues from different fish species. By considering the difference

in behaviour between the control and cue for each group it is still possible to make comparisons between groups.

Another experimental artefact can be seen in the fractal dimension data as the track complexities for all groups, including the control group, were higher after the water had been replaced in the arena. Although each parasite was left for 3-4 minutes to settle once it had been transferred to the arena using a pipette, this may not have been sufficient. In other similar experiments acclimatisation periods were 10 minutes for *L. salmonis* (Devine *et al.*, 2000) and 15 minutes for *T. longicornis* (Van Duren and Videler, 1995). It is likely that siphoning the water from the arena for the second part of each experiment would not stress the parasite as much as transferring it to the arena at the start of the experiment and, therefore, during the second part of each experiment it may have been more likely to exhibit normal behaviour.

4.3. Implications for host preference

The results of this experiment reinforce the conclusions of the previous chapter, in that there was a differential behavioural response to whiting and cod conditioned water. As these are both definitive hosts, a similar response may be expected for chemical cues from both species. However, in this experiment a strong response was seen for parasites exposed to whiting conditioned water and a similar, but much weaker, response when exposed to cod conditioned water. In the area where the parasites were collected, whiting are known to be the predominant host, so it is likely that all parasites used in the experiments originated from adult females infecting whiting. The possible reasons for this differential response for whiting and cod conditioned water are discussed in the previous chapter.

The behavioural response of *L. branchialis* to trout conditioned water was unexpected as trout are a non-target species. In the previous experiment parasites appeared to show a repulsive response to trout derived cues, but here their response to trout conditioned water was similar to their response to whiting conditioned water. A possible explanation for this unexpected behaviour may be the nature of the chemical cue in the water. There was no cue source and the concentration of the cue was equal in the whole arena. This may have confused the parasites as in a natural situation the concentration of the cue would be higher closer to the host. It may also demonstrate that cues other than chemical cues are necessary for host location and that a suitable host cannot easily be identified from chemical cues alone.

4.4. Implications for host location

Host location mechanisms can be divided into three categories: those which bring the parasite into the host's habitat; those which assist the parasite to respond to and come into contact with the fish; and those which allow the parasite to recognise a suitable host (Heuch *et al.*, 2007). Mechanisms used for the first phase of host location (inhabiting the same waters as the host) are not known in *L. branchialis* and may require the intermediate host to be in the same waters as the definitive host, although the swimming abilities of *L. branchialis* (discussed in Chapter 4) suggest that they may be able to swim a reasonable distance to locate a host. Mechanisms involved in this phase of host location may include aggregating in areas where potential hosts are likely to be found or chemo-reception of fish-derived chemicals. For example, *L. salmonis* aggregate in steep salinity gradients which may be frequented by feeding salmon (Heuch, 1995). The ability of *L. branchialis* to utilise fish-derived chemical

cues at this scale is dependant on odour landscapes, which are shaped by physical factors such as stirring and mixing in the water body (Moore and Crimaldi, 2004).

As the responses of *L. branchialis* to fish-derived chemical cues were not decisive in both the choice chamber and 3D behaviour experiments, it is likely that *L. branchialis* employs a range of mechanisms in the second (response to a potential host) and third (host recognition) phases in host location. In *L. branchialis* these other cues have yet to be determined, but in *L. salmonis* physical cues have been shown to play a role in host location. Copepodids of *L. salmonis* have been shown to react positively to directional light (Lewis, 1963; Bron *et al.*, 1993; MacKinnon, 1993; Pike *et al.*, 1993) and are sensitive to vibrations and flows, resulting in faster swimming and turning behaviour to attack fish (Bron *et al.*, 1993; Heuch and Karlsen, 1997; Heuch *et al.*, 2007). Heuch *et al.* (2007) showed that copepodids of *L. salmonis* respond positively to hydromechanical signals from fish in the absence of fish-derived chemicals, and suggested that physical cues are utilised for host detection and chemical cues are used for host recognition, once the parasite has attached to the host. Studies have shown that copepodids of *L. salmonis* will infect species other than salmonids, but will abandon these within hours of contact (Olsen, 2001). However, other workers have demonstrated that *L. salmonis* copepodids show an attraction response to host-derived chemical cues in choice chamber experiments (Devine *et al.*, 2000; Bailey *et al.*, 2006), showing that chemical cues have a role to play in locating a host. Similarly, it has been suggested that *L. pectoralis* uses physical stimuli, such as currents and vibrations, to locate the host and chemical stimuli to recognise a suitable host when in close proximity (Boxshall, 1976). A combination of chemical and physical cues are also used in the mating behaviour of free-living copepods, where water disturbance generated by a swimming female is a

mechanical cue for mate recognition, as well as the pheromone trail left by the female (Strickler and Bal, 1973; Uchima and Murano, 1988).

The results of this experiment suggest that in *L. branchialis* chemical cues are used to locate a host, as the addition of chemical cues in the water elicits a response that indicates host finding behaviour. However, the variation in behaviour and vague responses of some parasites suggests that chemical cues alone are not sufficient to locate and detect a host and it is likely that physical cues also have a role to play in host location. Once a host has been located chemical cues must also be used to ensure that it is a suitable species to infect. Chemical host identification on contact with the host has been demonstrated in *L. pectoralis* (Boxshall, 1976), *Lernaeenicus sprattae* (Sowerby, 1806) (Anstensrud and Schram, 1988) and *L. salmonis* (Bron *et al.*, 1991,1993). Therefore *L. branchialis* may utilise chemical cues to both locate a host and ensure that it is suitable for infection.

4.5. Experiment limitations and future work

In this experiment, a static system was used and therefore there was no concentration gradient of the chemical cue and no flow through the chamber. It may be possible that a concentration gradient and flow is important for *L. branchialis* to orientate to the cue source and locate it. The equal concentration of the chemical cue throughout the chamber may have confused the parasites as in a natural environment the concentration would be greater closer to the host, which would emit an odour trail, enabling the parasite to locate it along the concentration gradient of the trail. In the previous chapter, using the choice chamber, parasites were sometimes observed swimming in the inflow current of the chamber, indicating that *L. branchialis* may orientate themselves towards a current, which could have a role to play in host

location. As mentioned in Section 4.1 the behaviour of *L. branchialis* is similar to many other copepods in the presence of chemical cues, and defined structure such as concentration gradients and trails have been shown to be an important part of orientation to chemical cues (Doall *et al.*, 1998). It is likely that a chemical concentration gradient and a current flow is an important part of host location using chemical cues in *L. branchialis*, and not merely the presence of a chemical cue. The behaviour of *L. branchialis* in these experiments may have been a response to locate the odour trail in the presence of fish derived chemical cues. Other important considerations are the age of the parasites used in the experiments and the concentration of the chemical cue, which are discussed in the previous chapter.

The specific organs used for mechanical and chemical detection in *L. branchialis* are not known. In *L. salmonis* mechanosensory setae located on the antennules are used to guide the copepodid to a host (Heuch *et al.*, 2007), whereas chemosensory aesthetascs on the antennules allow the copepodid to recognise a suitable host (Bron *et al.*, 1991,1993). As the antennules of *L. branchialis* are equipped with many setae and one aesthetasc on each antennule, it is likely that these are used for mechosensory and chemosensory detection, although this requires examination.

For host location in *L. branchialis* to be fully understood, the role of physical cues requires investigation. It is likely that concentration gradients along odour trails produced by water currents are important to provide a directional cue and the relative importance of each of these factors requires investigation. Personal observations have shown that *L. branchialis* reacts positively to bright light, but whether their response is correlated to light intensity or if this is used for host location is not known. However, care needs to be taken interpreting this kind of response and relating it to their behaviour in a natural environment as it may be artefactual

(Forward, 1988; Pike, 1990). Other physical cues such as vibrations, flow fields, salinity and temperature gradients, and shadow responses also require investigation.

Chapter 6 - Conclusions

Lernaeocera branchialis (L.) has long been recognised as a pathogen of gadoid fish. The wide exploitation and commercial importance of cod (*Gadus morhua* L.), one of the key host species of *L. branchialis*, has led to extensive research of this parasite and its impact on its hosts. With the decline of the North Atlantic cod fisheries and the expansion of cod aquaculture within several North Atlantic countries, the emphasis of research into gadoids is shifting from a fisheries perspective to an aquaculture point of view.

In view of its often devastating effects on its host, *L. branchialis* has been identified as a potential threat to the development of gadoid aquaculture (Khan *et al.*, 1990; Lysne and Skorping, 2002; Anon, 2005). As with any new aquaculture species, it is important that its parasitic fauna be identified, their life-cycles determined and methods of intervention are developed (Burt and MacKinnon, 1997).

1. Study aims

Although the life-cycle of *L. branchialis* has been fully described by several authors (Claus, 1868; Scott, 1901; Wilson, 1917; Sproston, 1942), all of these descriptions are over 60 years old and there are a number of discrepancies in these, notably in the free-swimming stages of the parasite. Therefore, the initial aim of this study was to re-describe the free-swimming stages of *L. branchialis*, using current methodology and terminology. A further component within this was to explore the potential of using confocal microscopy and digital image processing to create accurate descriptions, using *L. branchialis* as an example.

One method of reducing the threat of parasites in aquaculture is to consider the life-cycle of the parasite and identify periods where intervention may impede progression to the next stage. In parasitic copepods, the planktonic free-swimming stages, where the parasite is seeking a new host, have been identified as vulnerable periods for the parasites where intervention may lead to methods of control. In *Lepeophtheirus salmonis* (Krøyer, 1837) the identification of chemical cues released from Atlantic salmon (*Salmo salar* L.), that are used to recognize and locate a host, have led to current research into the development of traps to attract salmon lice by the use of fish odours (Devine *et al.*, 2000; Ingvarsdottir *et al.*, 2002a,b). Therefore the second aim of this study was to determine the role of chemical cues in the host location of adult female *L. branchialis*, and whether there is potential for similar bio-control techniques in cod aquaculture.

2. Description of the juvenile free-swimming stages

In Chapter 3 the nauplius I, nauplius II and copepodid stages of *L. branchialis* were re-described. This study confirmed that there are two nauplius stages, although the timing of the moult between the nauplius I and nauplius II differs from previous descriptions by Whitfield *et al.* (1988) and Capart (1948). Whitfield *et al.* (1988) suggested that the moult to nauplius II occurs 24 hours after hatching and the moult to the copepodid occurs 48 hours after hatching, whereas Capart (1948) reported that copepodids were present 24 hours after hatching. In this study, the moult to nauplius II occurred 20-50 minutes after hatching at 10°C and the moult to the copepodid occurred 27-46 hours after hatching. The quick moults to the copepodid stage (<46 hours after hatching) compared to other siphonostomatoids may be an adaptation to improve survival rates, by shortening the vulnerable free-swimming planktonic stages. As the posterior processes at the terminal tip of the nauplius II are likely to be the developing caudal

rami, this stage has more than three functional pairs of appendages and, therefore, should be termed a meta-nauplius.

Composite images of image stacks from confocal microscopy have been successfully used to generate taxonomic drawings. By using digital contouring techniques it is possible to quickly and accurately generate these images without the skill and in-depth knowledge that is required for traditional light microscopy techniques. From this initial investigation some important considerations have been highlighted: fixing and staining of specimens to contrast the features of the specimen that are being studied, limitations of confocal microscopy in terms of specimen thickness, and the ability of contouring filters to delineate the features of the specimen. However, further investigation and development should allow many of these problems to be overcome. This technique has many benefits over traditional taxonomic methods: it is simple and rapid compared to drawing manually from light microscopy images; it is accurate, as boundaries and contours are detected automatically; fine structures are preserved and drawn accurately; structures that would not be visible using light microscopy can be imaged and drawn by using appropriate staining techniques. With further development, there is potential for this technique to become a powerful tool that can be used by taxonomists worldwide to consistently and accurately reproduce taxonomic drawings.

3. Parasite behaviour

In Chapters 4 and 5 the behaviour of free-swimming adult female *L. branchialis* and the role of fish derived chemical cues for host location were investigated to observe the response of parasites to chemical cues and determine the importance of chemical cues in host location. The study has revealed that the parasites predominantly remained close to the bottom of the arena, which is not surprising considering the demersal habitats of the

principal fish hosts. With the addition of fish-derived chemical cues, the parasites had higher velocities and turn rates, and spent more time moving, increasing the likelihood of encountering a fish host, which is a response similar to many other free-swimming copepods in the presence of chemical cues e.g. Uchima and Murano (1988), Doall *et al.* (1998), Devine *et al.* (2000).

Of all the chemical cues tested, whiting (*Merlangius merlangus* L.) and cod conditioned water proved the most attractive to *L. branchialis*. However, the results suggest that there may be different sub-species of *L. branchialis* that have a preference for either cod or whiting, as cod and whiting conditioned water induced different behavioural responses in these experiments. The discovery of sub-species in several other copepods (*Lepeophtheirus pectoralis* (Müller, 1776) (Boxshall, 1976), *Lepeophtheirus europaensis* Zeddum, 1988 (De Meeus *et al.*, 1992) and *Caligus elongatus* von Nordmann, 1832 (Øines and Heuch, 2005)) reinforces this theory. Sub-speciation is often attributed to the different environmental preferences of fish hosts and in *L. branchialis*, which has a two host life-cycle, the habitat overlap of the intermediate and definitive hosts may also play a role in sub-speciation. Kabata (1957, 1958) described *Lernaeocera obtusa*, which primarily infects lemon sole (*Microstomus kitt* (Walbaum, 1792)) and haddock (*Melanogrammus aeglefinus* (L.)) in offshore areas of the North Sea. Although *L. obtusa* was later reclassified as a form of *L. branchialis* that has a distinct metamorphosed adult shape due to the large size of its host, it may be a further sub-species of *L. branchialis* that prefers haddock to other gadoids. Investigation of the responses of *L. branchialis f. obtusa* to conditioned water from various gadoids would determine this, although genetic analysis of *L. branchialis* from different gadoids would be necessary to verify that these are sub-species and their preferences for different gadoids are not a result of pre-conditioning at the egg or nauplius stages.

It is clear from this work that although chemical cues elicited a host-seeking response in *L. branchialis*, they are not the only mechanism for host location in this species. Although these studies show that chemical cues have a role to play in host location, the wide variation of behavioural responses, leading to inconclusive results suggests that there are other factors involved, such as currents and vibrations. The nature of the chemical cues in the water may also be an important part of host location using chemical cues. The use of odour plumes by free-swimming parasitic copepods has been well documented e.g. Uchima and Murano (1988), Doall *et al.* (1998), Devine *et al.* (2000) and *L. branchialis* may require a chemical concentration gradient and water flow to demonstrate behaviour appropriate for host location. The behaviour of parasites in the choice chamber experiments suggests that they respond to water currents. As well as a lack of flow and concentration gradient of the chemical cues, other potential sources of error were identified in these experiments. The importance of thorough cleaning of the arena between each experiment to prevent contamination was demonstrated and a longer acclimatisation period after the parasite has been added to the arena may be beneficial. The age of parasites and concentration of the chemical cues may also affect the results of the experiments. Consideration of these points in future behaviour experiments may well improve the results.

4. Paratrack

Special parasite tracking software was developed for this study, which meant that it could be tailor-made for the experiments. The aim of the Paratrack software was to digitise the video files recorded from the choice chamber and 3D behaviour experiments (described in Chapters 3 and 4) and calculate suitable parameters to enable the behaviour of the parasites to be described and compared. Although several sophisticated software packages are available for this purpose (e.g. Motion Analysis Corporation,

Santa Clara, CA, USA; Ethovision, Noldus Information Technology, Wageningen, The Netherlands), their cost is prohibitive for individual studies, and as they are designed to be suitable for many different experimental situations there may be a complex procedure to set them up for a specific task. Although Paratrack was designed with specific applications in mind, it is flexible enough to be adapted to use in other similar experiments. The use of specifically designed software for digitising the tracks of free-swimming copepods has been described elsewhere, although this is limited to frame-by-frame track digitisation (Van Duren and Videler, 1995).

In practice, the main limitation of Paratrack in this study was the sensitivity of parasite detection within individual frames. Although Paratrack can recognise individual colour shades, when the parasite swims rapidly or is positioned vertically or close to the edge of the arena, it is often not distinguishable from the background. A great deal of time was spent optimising the lighting regime and the detection parameters to ensure that the parasite was contrasted against the background. However, the size (~1.2mm) and the colour of the parasite meant that it was often undetectable within frames analysed by Paratrack and the position of the parasite had to be marked manually by eye. In some experiments the parasite remained undetected and had to be marked manually in up to 75% of the frames. Further development of the experimental setup and video capture, as well as detection techniques in Paratrack, such as the use of adaptive detection thresholds may improve parasite tracking in future studies.

The accuracy of Paratrack in locating the parasite in individual frames also requires careful consideration. An algorithm was developed to correct for distortion of the image due to perspective and it was verified by recording the co-ordinates of an object at known locations in the arena. However, this method of perspective correction is

sensitive to small deviations in input parameters, such as the camera zoom level and mirror angle, resulting in inaccuracies in the corrected co-ordinates.

In its present form the calculation of fractal dimensions in Paratrack is simple and requires further development to improve the accuracy of this technique. In theory values of fractal dimensions should fall between 1 and 2. However, in this study several values were less than 1. By introducing a calibration factor calculated from a straight line (Uttieri *et al.*, 2005) and transforming the data this problem should be avoided. Also, path crossovers and overlaps reduce the efficiency of the technique (O'Brien *et al.*, 1989) and, therefore, the ability of Paratrack to recognise repeated occupancy of one point by the parasite should improve accuracy.

Further development of Paratrack to improve the digitisation process and increase the number of different descriptive parameters that can be calculated from the digitised track could lead to a tool that can be used for different studies other than those described here. As Paratrack was developed additively, the Graphical User Interface (GUI) appears cluttered, making it difficult to navigate for new users. A reorganisation of the GUI using drop down menus would result in a tracking tool that is simple to use for many applications where free-swimming organisms require tracking in a confined arena.

5. *Lernaeocera branchialis* and aquaculture

Although *L. branchialis* has been identified as a potential pathogen to cod aquaculture (Khan *et al.*, 1990; Burt and MacKinnon, 1997; Anon, 2005), no serious infestations of *L. branchialis* in caged cod have been reported to date. There are several possible reasons for this. In Scotland, cod aquaculture has been slow to establish and is currently very limited with only a few sites farming cod. This may be due to the lack of available

sites for cod aquaculture, as licences for new sites are unlikely to be granted and, therefore, the only way to farm cod is to change existing salmon farms over to cod farms. Also, technology is still under development for cod aquaculture, especially for hatcheries and diets, as the supply of fingerlings for cod aquaculture is currently unreliable. Moreover, the lessons learnt from salmon farming in the last 30+ years may mean that farmers are cautious and reluctant to switch over to cod farming until the industry has become established. Once the technology has been perfected, a reliable source of fingerlings has been established, and several pioneers have taken the plunge and switched to cod farming, it is likely that there will be a rapid increase in the number of farms growing cod. It may be at this time that parasite infections, such as *L. branchialis*, will become a problem. A similar pattern was seen in salmon farming in the 1970s, where infection by *L. salmonis* was not considered a problem until the number of salmon farms reached a certain threshold, resulting in a rapid increase in the number of farms with *L. salmonis* infections (Sommerville *pers. comm.*). However, unlike *L. salmonis*, which has a direct life-cycle, allowing an infestation to manifest itself within a cage environment, *L. branchialis* cannot complete its life-cycle within a cage as it requires two hosts. This is an additional factor that may further determine the prevalence and distribution of *L. branchialis* in farmed cod.

Although in Scotland cod farming has been slow to establish and is a relatively new industry, it is becoming widespread in Norway, where cod have been farmed for several years, and yet *L. branchialis* infection has not been a significant problem for the Norwegian cod farming industry (Reynolds *pers. comm.*). This may be due to the nature of the environment where cod are farmed in Norway. As the cages are usually located in fjords that are often over 100m deep, it is unlikely that *L. branchialis* infecting flatfish on the seabed will come into contact with caged cod near the surface. The swimming

abilities of *L. branchialis* demonstrated in this study (14.25 m/hr mean in control parasites) indicate that they are capable of reaching caged cod at the surface from the seabed, although as this study has demonstrated that they typically remain close to the bottom, it is unlikely that they will make the journey to the surface. Fish odour from caged cod is unlikely to reach *L. branchialis* on the seabed as most Norwegian fjords are highly stratified, with little mixing of deep water with surface water. However, in Scotland, where cages are located in shallower, highly dynamic coastal areas, there is potential for caged cod to become infected with *L. branchialis* from flatfish living on the seabed. As demonstrated in this study and in the literature (Chapter 1 Section 7.2) *L. branchialis* is widespread around the UK coastline and the prevalence of infection is often high, especially in estuarine habitats and, therefore, there is a high probability that infection will be transmitted from wild to farmed fish.

Whether there is a need to control *L. branchialis* infection in commercially farmed cod has yet to be established and will mostly likely depend on the future development of the cod aquaculture industries. However, the efficacy of existing chemotherapeutants, such as emamectin benzoate (SLICE, Schering Plough), in controlling *L. branchialis* infection should be determined. Whether there is potential to develop biological control measures using chemical cues is dependant on several factors: the relative importance of chemical cues and physical cues for host location in *L. branchialis*, the isolation of specific chemicals that are used in host location in *L. branchialis*, and the use of other management techniques for controlling *L. branchialis* infection. Successful prevention of *L. branchialis* infection in farmed cod may simply involve locating the cages away from the known habitats of the intermediate hosts. As infection of farmed cod with *L. branchialis* requires a source of infection from outside the cages, locating cages away from a potential source of infection may significantly reduce the chance of transmission

from the intermediate to definitive host. Although the swimming ability of adult female *L. branchialis* was estimated in this study, their survival time, once they have left the intermediate host, is unknown and should be investigated. These factors, as well as local currents and tidal regimes will determine the chance of transmission of *L. branchialis* from wild to farmed fish.

The possible sub-speciation of *L. branchialis* may be used to reduce infection of caged cod. In areas where other gadoids are known to be the preferred host, e.g. whiting in the Firth of Forth, caged cod may be less likely to be infected where whiting hosts are plentiful. Although it is possible for *L. branchialis* originating from whiting to infect cod, the success of such infections is unknown. The effectiveness of such strategies for controlling *L. branchialis* infection in farmed cod should be established.

Prevention of infection by *L. branchialis* in caged cod may also be achieved by selective breeding of cod. It is known that some fish are resistant to infection by *L. branchialis*, although it may be possible that resistance has a cost in terms of reduced growth, as in a study where caged cod were infected with *L. branchialis*, fish that were free from infection had slower growth rates than fish infected with one parasite (Lysne *et al.*, 2006). By implementing a selective breeding programme, it may be possible to breed a strain of cod that is resistant to *L. branchialis* infection, without compromising growth.

6. Future potential and further work

With the renewed interest in *L. branchialis* as a result of the emerging cod aquaculture industry it is likely that the volume of new research involving this potentially devastating pathogen will increase. Much of the work described in this study is involved with areas of *L. branchialis* biology that have not been considered in depth before. As a

result of these initial studies, several topics have been highlighted that require further investigation to fully understand the biology of *L. branchialis* and its host-parasite interactions. Although the use of chemical cues in host location in *L. branchialis* has been demonstrated, the results are not conclusive and require further exploration, taking into consideration the points mentioned in Section 3. The role of physical cues in host location in *L. branchialis*, such as water currents, vibrations and shadow responses also require investigation and the relative importance of chemical and physical cues should be established. Only then should attempts be made to isolate the specific chemical(s) that are involved in host location in *L. branchialis*, possibly using techniques such as gas chromatography and mass spectrometry as used by Ingvarsdottir *et al.* (2002b) to identify chemicals used for host location in *L. salmonis*.

Furthermore, the different behavioural response of *L. branchialis* to conditioned water from cod and whiting and the possible sub-speciation of *L. branchialis* require further examination. Although this study was not designed to explore sub-speciation in *L. branchialis*, the different responses of the parasites to whiting and cod conditioned water is an interesting result, as *L. branchialis* populations were previously thought to be genetically homogenous, with no preference for one host species over another. The behavioural responses of *L. branchialis* from different areas, infecting other hosts, to conditioned water from a variety of different gadoids should be investigated to determine whether other strains of *L. branchialis* exist and genetic analysis could be used to reveal if these are in fact sub-species of *L. branchialis* and not a result of pre-conditioning at the egg or nauplius stages.

As well as improving our knowledge of *L. branchialis* biology and highlighting areas that require further work, this study has led to the development of new methodology

that shows great promise for future use. The Paratrack software has been used to good effect to digitise the movement paths of *L. branchialis* and describe its behaviour using a variety of behavioural parameters. By improving the detection and digitisation process, increasing the number of different parameters that can be calculated from the tracks, and improving the GUI, there is potential for Paratrack to become a powerful tool. Given the right funding and research, the suite of functions available in the current Paratrack software could be expanded and improved, leading to a software package that allows rapid and accurate digitisation and parameterisation of animal movements and could rival commercially available software for specialised applications involving the analysis and description of the behaviour of free-swimming organisms.

A further method used in this study, which shows great potential, is the use of confocal microscopy and contour filters for generating taxonomic drawings. Imaging specimens using confocal microscopy allows the rapid generation of images that are in sharp focus throughout the entire specimen and can highlight different features depending on the fixing and staining methods used. As this initial study has shown, taxonomic drawings can be quickly and easily generated from composite confocal microscope images by using a basic contour filter in a proprietary software package. There is potential here for the development of contour filters designed specifically for extracting taxonomic information from specimens imaged using confocal microscopy. Given the benefits of this technique (e.g. rapid, accurate, simple), and with further development and refinement this could become a viable alternative to morphology-based taxonomic descriptions using traditional techniques.

It is clear from the literature that *Lernaeocera branchialis* is capable of severely affecting the health of gadoid fish and, therefore, poses a serious threat to the decimated

and fragile wild gadoid populations and the emerging cod aquaculture industry. With the renewed interest in *L. branchialis* due to the emergence of cod as a potentially important species for aquaculture, and the threat that this pathogen poses to the gadoid aquaculture industries, there are a number of areas of *L. branchialis* biology and host-parasite interactions that require investigation if we are to anticipate the problems and mitigate the effects of this pathogen. This study has focused on two specific phases of the life-cycle of *L. branchialis*: the juvenile free-swimming stages and the free-swimming adult female. This work has improved our knowledge of the biology and life-cycle of *L. branchialis*, specifically, the morphology of the juvenile free-swimming stages and the role of chemical cues in host location, and has highlighted areas that require further investigation. Moreover, techniques have been developed for tracking and analysing the behaviour of free-swimming organisms, and generating taxonomic drawings using confocal microscopy. These techniques show great potential and with further development may evolve into powerful research tools. With further study of mechanisms used for host location in *L. branchialis*, as well as other important areas of *L. branchialis* biology and its host-parasite interactions, it should be possible to develop contingency plans for the effective management and control of this widespread and potentially devastating pathogen.

References

- Al Abassi, A., Birkett, M.A., Pettersson, J., Pickett, J.A. and Wadhams, L.J. (2000) Response of the seven-spot ladybird to an aphid alarm pheromone and an alarm pheromone inhibitor is mediated by paired olfactory cells. *Journal of Chemical Ecology* **26**, 1765-1771.
- Anon (2005) Final report of the Aquaculture Health Joint Working Group sub-group on disease risks and interactions between farmed salmonids and emerging marine aquaculture species, 54pp.
- Anstensrud, M. (1989) Experimental studies of the reproductive behaviour of the parasitic copepod *Lernaeocera branchialis* (Pennellidae). *Journal of the Marine Biological Association of the UK* **69**, 465-476.
- Anstensrud, M. (1990a) Effects of mating on female behaviour and allometric growth in the two parasitic copepods *Lernaeocera branchialis* (L., 1767) (Pennellidae) and *Lepeophtheirus pectoralis* (Müller, 1776) (Caligidae). *Crustaceana* **59**, 245-258.
- Anstensrud, M. (1990b) Male reproductive characteristics of two parasitic copepods, *Lernaeocera branchialis* (L.) (Pennellidae) and *Lepeophtheirus pectoralis* (Müller) (Caligidae). *Journal of Crustacean Biology* **10**, 627-638.
- Anstensrud, M. (1990c) Mating strategies of two parasitic copepods (*Lernaeocera branchialis* (L.) (Pennellidae) and *Lepeophtheirus pectoralis* (Müller) (Caligidae)) on flounder: polygamy, sex-specific age at maturity and sex ratio. *Journal of Experimental Marine Biology and Ecology* **136**, 141-158.

- Anstensrud, M. (1992) Mate guarding and mate choice in two copepods, *Lernaeocera branchialis* (L) (Pennellidae) and *Lepeophtheirus pectoralis* (Müller) (Caligidae), parasites on flounder. *Journal of Crustacean Biology* **12**, 31-40.
- Anstensrud, M. and Schram, T.A. (1988) Host and site selection by larval stages and adults of the parasitic copepod *Lernaeenicus sprattae* (Sowerby)(Copepoda, Pennellidae) in the Oslofjord. *Hydrobiologia* **167/168**, 587-595.
- Arbuckle, T. (2000) Automatic identification of bee species from images of their wings. *Proceedings of the 9th International Workshop on Systems, Signals and Image Processing*. pp. 509-511. Manchester: UMIST
- Arbuckle, T., Schröder, S., Steinhage, V. and Wittmann, D. (2001) Biodiversity informatics in action: identification and monitoring of bee species using ABIS. *Proceedings of the 15th International Symposium on Informatics for Environmental Protection* pp. 425-430. Zurich: Metropolis
- Bailey, R.J.E., Birkett, M.A. and Ingvarsdottir, A. (2006) The role of semiochemicals in host location and non-host avoidance by salmon louse (*Lepeophtheirus salmonis*) copepodids. *Canadian Journal of Fisheries and Aquatic Science* **63**, 448-456.
- Begg, G.S. and Bruno, D.W. (1999) The common dab as definitive host for the Pennelid copepods *Lernaeocera branchialis* and *Haemobaphes cyclopterina*. *Journal of Fish Biology* **55**, 655-657.
- Boudreau, B., Bourget, E. and Simard, Y. (1993) Behavioural responses of competent lobster post-larvae to odor plumes. *Marine Biology* **117**, 63-69.

- Boxshall, G.A. (1974) Infections with parasitic copepods in North Sea marine fishes. *Journal of the Marine Biological Association of the UK* **54**, 355-372.
- Boxshall, G.A. (1976) The host specificity of *Lepeophtheirus pectoralis* (Müller, 1776) (Copepoda: Caligidae). *Journal of Fish Biology* **8**, 255-264.
- Boxshall, G.A. (1990a) Precopulatory mate guarding in copepods. *Bijdragen tot Dierkunde* **60**, 209-213.
- Boxshall, G.A. (1990b) The skeletomusculature of siphonostomatoid copepods, with an analysis of adaptive radiation in structure of the oral cone. *Philosophical Transactions of the Royal Society London Series B* **328**, 167-212.
- Boxshall, G.A. (1992) Copepoda. In: *Microscopic Anatomy of Invertebrates Volume 9: Crustacea.*, pp. 347-384. Wiley-Liss, Inc.
- Brandal, P.O., Egidius, E. and Romslo, I. (1976) Host blood: a major food component for the parasitic copepod *Lepeophtheirus salmonis* Krøyer 1838 (Crustacea: Caligidae). *Norwegian Journal of Zoology* **24**, 431-443.
- Brewer, M.C. (1998) Mating behaviours of *Daphnia pulex*, a cyclic parthenogen: comparisons with copepods. *Philosophical Transactions of the Royal Society Series B* **353**, 805-815.
- Brian, A. (1906) Copepodi parassiti dei pesci d'Italia. Genova. 190pp
- Bricknell, I.R., Bron, J.E., Cook, P. and Adamson, K. (2003) Is blood an important component of the diet of sea lice? *Proceedings of the 6th International Conference on Biology and Control of Sea Lice*, St Andrews, NB, July 1-4

- Brinkworth, R.I., Harrop, S.A., Prociv, P. and Brindley, P.J. (2000) Host specificity in blood feeding parasites: a defining contribution by haemoglobin-degrading enzymes? *International Journal for Parasitology* **30**, 785-790.
- Bron, J.E., Sommerville, C., Jones, M. and Rae, G.H. (1991) The settlement and attachment of early stages of the salmon louse, *Lepeophtheirus salmonis* (Copepoda: Caligidae) on the salmon host, *Salmo salar*. *Journal of Zoology* **224**, 201-212.
- Bron, J.E., Sommerville, C. and Rae, G.H. (1993) Aspects of the behaviour of the salmon louse *Lepeophtheirus salmonis* (Krøyer, 1837). In: Boxshall, G.A. and Defaye, D. (Eds.) *Pathogens of Wild and Farmed Fish: Sea Lice.*, pp. 125-142. Chichester, UK: Ellis Horwood.
- Brown, W.L.Jr. (1968) A hypothesis concerning the function of the metapleural glands in ants. *American Naturalist* **102**, 188-191.
- Brown, W.L.Jr., Esiner, T. and Whittaker, R.H. (1970) Allomones and kairomones: transspecific chemical messengers. *Bioscience* **20**, 21-22.
- Burt, M.D.B. and MacKinnon, B.M. (1997) Parasites and marine aquaculture. *ACC Special Publication* **2**, 65-68.
- Busky, E.J. (1984) Swimming pattern as an indicator of the roles of copepod sensory systems in the recognition of food. *Marine Biology* **79**, 165-175.
- Capart, A. (1947) Le *Lernaeocera branchialis* (L.), copepode parasite des gadides. *Journal du Conseil International pour l'Exploration de la Mer* **15**, 69-76.
- Capart, A. (1948) *Lernaeocera branchialis*. *Cellulae* **52**, 159-212.

- Carte, B. and Faulkner, D.J. (1986) Role of secondary metabolites in feeding associations between a predatory nudibranch, 2 grazing nudibranchs, and a bryozoan. *Journal of Chemical Ecology* **12**, 795-804.
- Chrásková, J., Kaminsky, Y. and Krekule, I. (1999) An automatic 3D tracking system with a PC and a single TV camera. *Journal of Neuroscience Methods* **88**, 195-200.
- Claus, C. (1868a) Beobachtungen über *Lernaeocera*, *Peniculus* und *Lernaea*. Ein Beitrag zur Naturgeschichte der Lernaeen. *Schriften der Gesellschaft Naturforschenden zu Marburg* **9**, 1-32.
- Claus, C. (1868b) Über die Metamorphose und systematische Stellung der Lernaeen. *Sitzungsberichte der Gesellschaft zur Beforderung der Gesamten Naturwissenschaften zu Marburg* **2**, 5-13.
- Cohen, D.M., Inada, T., Iwamoto, T. and Scialabba, N. (1990) FAO species catalogue. Vol. 10. Gadiform fishes of the world (Order Gadiformes). An annotated and illustrated catalogue of cods, hakes, grenadiers and other gadiform fishes known to date. *FAO species synopsis* **125**, 442pp
- Coughlin, D.J., Strickler, J.R. and Sanderson, B. (1992) Swimming and search behaviour in clownfish, *Amphiprion perideraion* larvae. *Animal Behaviour* **44**, 427-440.
- Crenshaw, H.C., Ciampaglio, C.N. and McHenry, M. (2000) Analysis of the three-dimensional trajectories of organisms: estimates of velocity, curvature and torsion from positional information. *The Journal of Experimental Biology* **203**, 961-982.

- De Beauchamp, P. (1952) Un facteur de la variabilité chez les rotifées du genre *Brachionus*. *Comptes Rendu de l'Académie des Sciences* **234**, 573-575.
- De Meeus, T., Marin, R. and Renaud, F. (1992) Genetic heterogeneity within populations of *Lepeophtheirus europaensis* (Copepoda: Caligidae) parasitic on two host species. *International Journal for Parasitology* **22**, 1179-1181.
- Denunz, M.O. and Haas, W. (1991) Penetration stimuli of fish skin for *Acanthostomum brauni* cercariae. *Parasitology* **102**, 101-104.
- Desbrosses, P. (1945) Le merlan (*Gadus merlangus* L.) de la côte Française de l'Atlantique. *Revue des Travaux de l'Office de Pêches Maritimes Paris* **13**, 177-195.
- Devine, G., Ingvarsdottir, A., Mordue, W., Pike, A., Pickett, J., Duce, I. and Mordue, A. (2000) Salmon lice, *Lepeophtheirus salmonis*, exhibit specific chemotactic responses to semiochemicals originating from the salmonid, *Salmo salar*. *Journal of Chemical Ecology* **26**, 1833-1848.
- Dietrich, C.H. and Pooley, C.D. (1994) Automated identification of leafhoppers (Homoptera: Cicadellidae: *Draeculacephala* Ball). *Annals of the Entomological Society of America* **87**, 412-423.
- Doall, M.H., Colin, S.P., Strickler, J.R. and Yen, J. (1998) Locating a mate in 3D: the case of *Temora longicornis*. *Philosophical Transactions of the Royal Society Series B* **353**, 681-689.
- Doving, K.B., Westerberg, H. and Johnsen, P.B. (1985) Role of olfaction in the behavioural and neuronal responses of Atlantic salmon, *Salmo salar*, to

- hydrographic stratification. *Canadian Journal of Fisheries and Aquaculture* **42**, 1658-1667.
- Dutil, J.D. and Coutu, J.M. (1988) Early marine life of the Atlantic salmon, *Salmo salar*, post smolts in the northern Gulf of St. Lawrence. *Fisheries Bulletin US* **86**, 197-212.
- Dutton, A., Mattiacci, L. and Dorn, S. (2000) Plant-derived semiochemicals as contact host location stimuli for a parasitoid of leafminers. *Journal of Chemical Ecology* **26**, 2259-2273.
- Edwards, J.A. and Whitfield, P.J. (1983) Development stages of the parasitic copepod, *Lernaeocera branchialis* on the flounder, *Platichthys flesus*. *Parasitology* **87**
- Edwards, J.A. (1984) The utilisation of the gills of flounder (*Platichthys flesus*) by the parasitic copepod *Lernaeocera branchialis*. *Parasitology* **89**
- Eiras, J.C. (1986) Some aspects of the infection of bib, *Trisopterus luscus* (L.), by the parasitic copepod *Lernaeocera lusci* (Bassett-Smith, 1896) in Portuguese waters. *Journal of Fish Biology* **28**, 141-145.
- El-Darsh, H.E.M. (1999) The parasite community infecting flounders, *Platichthys flesus*, in the tidal Thames. *Journal of Helminthology* **73**, 203-214
- Faldt, J., Jonsell, M., Nordlander, G. and Borg-Karlson, A.K. (1999) Volatiles of bracket fungi *Fomitopsis pinicola* and *Fomes fomentarius* and their functions as insect attractants. *Journal of Chemical Ecology* **25**, 567-590.
- Fast, M.D., Burka, J.F., Johnson, S.C. and Ross, N.W. (2003) Enzymes released from *Lepeophtheirus salmonis* in response to mucus from different salmonids.

Journal of Parasitology **89**, 7-13.

Fast, M.D., Ross, N.W., Craft, C.A., Locke, S.J., MacKinnon, S.L. and Johnson, S.C. (2004) *Lepeophtheirus salmonis*: a characterization of prostaglandin E₂ in secretory products of the salmon louse by RP-HPLC and mass spectrometry. *Experimental Parasitology* **107**, 5-13.

Fast, M.D., Ross, N.W., Mustafa, A., Sims, D.E., Johnson, S.C., Conboy, G.A., Speare, D.J., Johnson, G. and Burka, J.F. (2002) Susceptibility of rainbow trout *Oncorhynchus mykiss*, Atlantic salmon *Salmo salar* and coho salmon *Oncorhynchus kisutch* to experimental infection with sea lice *Lepeophtheirus salmonis*. *Diseases of Aquatic Organisms* **52**, 57-68.

Fleming, A.M. and Templeman, W. (1951) Discovery of larval forms of *Lernaeocera branchialis* on lumpfish. *Fisheries Research Board Canadian Biological Station St. John's, Newfoundland Annual Report* **47**

Fox, M.H. (1945) Haemoglobin in blood-sucking parasites. *Nature* **156**, 475-476.

Fraile, L., Escoufier, Y. and Raibaut, A. (1993) Analyse des correspondances de données planifiées: étude de la chémotaxie de la larve infestante d'un parasite. *Biometrics* **49**, 1142-1153.

Frey, M.A., Lonsdale, D.J. and Snell, T.W. (1998) The influence of contact chemical signals on mate recognition in a harpacticoid copepod. *Philosophical Transactions of the Royal Society Series B* **353**, 745-751.

Gaston, K.J. and O'Neill, M.A. (2004) Automated species identification: why not? *Philosophical Transactions of the Royal Society, London Series B* **359**, 655-

667.

- Gauld, I.D., O'Neill, M.A. and Gaston, K.J. (2000) Driving Miss DAISY: the performance of an automated insect identification system. In: Austin, A. D.; Downton, M. (Eds.) *Hymenoptera: Evolution, Biodiversity and Biological Control.*, pp. 303-312. Collingwood, VIC: CSIRO
- Gomori, G.L. (1950) A rapid one-step trichome stain. *American Journal of Clinical Pathology* **20**, 661-664.
- Gonzalez-Alanis, P., Wright, G.M., Johnson, S.C. and Burka, J.F. (2001) Frontal filament morphogenesis in the salmon louser *Lepeoptheirus salmonis*. *Journal of Parasitology* **87**, 561-574.
- Gouillart, M. (1937) Recherches sur les copepodes parasites (biologie, spermatogenese, ovogenese). *Travaux de la Station Zoologique de Wimereux, Paris* **12**, 308-457.
- Grant, H.J. and Whitfield, .P.J. (1988) The ultrastructure of the spermatozoon of *Lernaeocera branchialis* (Copepoda, Pennellidae). *Hydrobiologia* **167**, 607-616.
- Griffiths, A.M. and Frost, B.W. (1976) Chemical communication in the marine planktonic copepods *Calanus pacificus* and *Pseudocalanus* sp. *Crustaceana* **30**, 1-9.
- Haas, W. (1974a) Analyse der invasionsmechanismen der cercarie von *Diplostomum spathaceum*. I. Fixation and penetration. *International Journal of Parasitology* **4**, 311-319.

- Haas, W. (1974b) Analyse der invasionsmechanismen der cercarie von *Diplostomum spathaceum*. II. Chemische invasionsstimuli. *International Journal of Parasitology* **4**, 321-330.
- Haas, W. (1975) Einfluss von CO₂ und pH auf das fixationsverhalten der cercarie von *Diplostomum spathaceum* (Trematoda). *Zeitschrift für Parasitenkunde* **46**, 53-60.
- Haas, W., Stiegeler, P., Keating, A., Kullmann, B., Rabenau, H., Schönamsgruber, E. and Haberl, B. (2002) *Diplostomum spathaceum* cercariae respond to a unique profile of cues during recognition of their fish host. *International Journal for Parasitology* **32**, 1145-1154.
- Halley, J.M., Hartley, S. and Kallimanis, A.S. (2004) Uses and abuses of fractal methodology in ecology. *Ecological Letters* **7**, 254-271.
- Hansen, H.J. (1923) Crustacea Copepoda II. Copepoda parasita and hemiparasita. *Danish Ingolf Expedition, Copenhagen* **7**, 1-92.
- Hastings, H.M. and Sugihara, G. (1993) *Fractals: A User's Guide for the Natural Sciences.*, Oxford: Oxford Science Publications. 235pp.
- Hemmingsen, W., Lile, N. and Halvorsen, O. (1995) Search for seasonality in occurrence of parasites of cod, *Gadus morhua* L. in a fjord at 70° N. *Polar Biology* **15**, 517-522.
- Hemmingsen, W., Halvorsen, O. and MacKenzie, K. (2000) The occurrence of some metazoan parasites of Atlantic cod, *Gadus morhua* L., in relation to age and sex of the host in Balsfjord (70° N), North Norway. *Polar Biology* **23**, 368-372.

- Hendrichs, J., Katsoyannos, B.I., Wornoayporn, V. and Hendrichs, H.A. (1994) Odour-mediated foraging by yellowjacket wasps (Hymenoptera: Vespidae): predation on leks of pheromone-calling mediterranean fruit fly males (Diptera: Tephritidae). *Oecologia* **99**, 88-94.
- Heuch, P.A. (1995) Experimental evidence for aggregation of salmon louse copepodids (*Lepeophtheirus salmonis*) in step salinity gradients. *Journal of the Marine Biological Association of the UK* **75**, 927-939.
- Heuch, P.A., Parsons, A. and Boxaspen, K. (1995) Diel vertical migration: a possible host-finding mechanism in salmon louse (*Lepeophtheirus salmonis*) copepodids? *Canadian Journal of Fisheries and Aquatic Sciences* **52**, 681-689.
- Heuch, P. A. and Schram, T. A. (1996) Male mate choice in a natural population of the parasitic copepod *Lernaeocera branchialis* (Copepoda: Pennellidae). *Behaviour* **133**, 221-239.
- Heuch, P.A. and Karlsen, H.E. (1997) Detection of infrasonic water oscillations by copepodids of *Lepeophtheirus salmonis* (Copepoda: Caligidae). *Journal of Plankton Research* **19**, 735-747.
- Heuch, P.A., Doall, M.H. and Yen, J. (2007) Water flow around a fish mimic attracts a parasitic and deters a planktonic copepod. *Journal of Plankton Research* **29**, i3-i16
- Hislop, J.R.G. and Shanks, A.M. (1981) Recent investigations on the reproductive biology of the haddock, *Melanogrammus aeglefinus*, of the northern North Sea and the effects on fecundity of infection with the copepod parasite *Lernaeocera branchialis*. *Journal du Conseil Permanent International par l'Exploration de*

la Mer **39**, 244-251.

- Ho, J.S. (1966) Larval stages of *Cardiodectes* sp. (Caligoida: Lernaecoceriformes), a copepod parasitic on fishes. *Bulletin of Marine Science* **16**, 159-199.
- Holm, M., Huse, I., Waatevik, E., Doving, K.B. and Aure, J. (1982) *Behaviour of Atlantic salmon smolts during seaward migration. I. Preliminary report on ultrasonic tracking in a Norwegian fjord*. C.M. 1982/M:7, Copenhagen: International Council for the Exploration of the Sea.
- Huber, H., Pokey, M.J., Linscott, W.D., Fudenburg, H.H. and Muller-Eberhard, H.J. (1968) Human monocytes: Distinct receptor sites for the 3rd component of complement and for IgG. *Science* **162**, 1281-1283.
- Hull, M.Q., Pike, A.J., Mordue (Luntz), A.J. and Rae, G.H. (1998) Patterns of pair formation and mating in an ectoparasitic caligid copepod *Lepeophtheirus salmonis* (Krøyer 1837): implications for its sensory and mating biology. *Philosophical Transactions of the Royal Society London Series B* **353**, 753-764.
- Huys, R. and Boxshall, G.A. (1991) *Copepod Evolution*, London: Ray Society.
- Hwang, J.S., Turner, J.T., Costello, J.H., Coughlin, D.J. and Strickler, J.R. (1993) A cinematographic comparison of behaviour by the calanoid copepod *Centropages hamatus* Lilljeborg: Tethered versus free-swimming animals. *Experimental Marine Biology and Ecology* **167**, 277-288.
- Ingvarsdottir, A., Birkett, M.A., Duce, I., Mordue, W., Pickett, J.A., Wadhams, L.J. and Mordue, A.J. (2002a) Role of semiochemicals in mate location by parasitic sea louse *Lepeophtheirus salmonis*. *Journal of Chemical Ecology* **28**, 2107-2117.

- Ingvarsdottir, A., Birkett, M., Duce, I., Genna, R., Mordue, W., Pickett, J., Wadhams, L. and Mordue, A. (2002b) Semiochemical strategies for sea louse control: host location cues. *Pest Management Science* **58**, 537-545.
- Jacoby, C.A. and Youngbluth, M.J. (1983) Mating behaviour in three species of *Pseudodiaptomus* (Copepoda: Calanoida). *Marine Biology* **76**, 77-86.
- Jamieson, C.D. (2005) Coexistence of two similar copepod species, *Eudiaptomus gracilis* and *E. graciloides*: the role of differential predator avoidance. *Hydrobiologia* **542**, 191-202.
- Johnson, S.C. and Albright, L.J. (1991) The developmental stages of *Lepeoptheirus salmonis* (Krøyer, 1837) (Copepoda: Caligidae). *Canadian Journal of Zoology* **69**, 929-950.
- Jones, M. E. B. and Taggart, C. T. (1998) Distribution of gill parasite (*Lernaeocera branchialis*) infection in Northwest Atlantic cod (*Gadus morhua*) and parasite-induced host mortality: inferences from tagging data. *Canadian Journal of Fisheries and Aquatic Science* **55**, 364-375.
- Jonker, R., Groben, R., Tarran, G., Medlin, L., Wilkins, M., Garcia, L., Zabala, L. and Boddy, L. (2000) Automated identification and characterisation of microbial populations using flow cytometry: the AIMS project. *Scientia Marina* **64**, 225-234.
- Jungersen, H.F.E. (1913) On a new gymnoblastic hydroid (*Ichthyocodium sarcotretis*) epizoic on a new parasitic copepod (*Sarcotretes scopeli*) infesting *Scopelus glacialis* Rhdt - *Vidensk. Videnskabelige Meddelelser fra Dansk Naturhistoriske Forening, Copenhagen* **64**, 1-33.

- Kabata, Z. (1957) *Lernaeocera obtusa* n. sp. a hitherto undescribed parasite of the haddock (*Gadus aeglefinus*). *Journal of the Marine Biological Association of the UK* **36**, 569-592.
- Kabata, Z. (1958) *Lernaeocera obtusa*. n. sp. its biology and its effects on the haddock. *Marine Research* **3**, 26pp
- Kabata, Z. (1961) *Lernaeocera branchialis* (L.), a parasitic copepod from the European and American shores of the Atlantic. *Crustaceana* **2**, 243-249.
- Kabata, Z. (1962) The mouth and mouthparts of *Lernaeocera branchialis* L. *Crustaceana* **3**, 311-317.
- Kabata, Z. (1965) *Lernaeocera* (Copepoda) parasitic on ling (*Molva elongata* Otto.). *Crustaceana* **9**, 104-105.
- Kabata, Z. (1970) Crustacea as enemies of fishes. In: *Diseases of Fishes Book 1* S. F. Snieszko & H. R. Axelrod (Eds.) 171pp
- Kabata, Z. (1979) Parasitic Copepoda of British fishes. *Ray Society, London* 468pp
- Karlson, P. and Lüscher, M. (1959) Pheromones: a new term for a class of biologically active substances. *Nature* **183**, 55-56.
- Katona, S.K. (1973) Evidence for sex pheromones in planktonic copepods. *Limnology and Oceanography* **18**, 574-583.
- Kelly, L.S., Snell, T.W. and Lonsdale, D.J. (1998) Chemical communication during mating of the harpacticoid *Tigriopus japonicus*. *Philosophical Transactions of the Royal Society Series B* **353**, 737-744.

- Kerlin, R.L. and Hughes, S. (1992) Enzymes in saliva from four parasitic arthropods. *Medical and Veterinary Entomology* **6**, 121-126.
- Khan, R.A. (1988) Experimental transmission, development, and effects of a parasitic copepod, *Lernaeocera branchialis*, on Atlantic cod, *Gadus morhua*. *Journal of Parasitology* **74**, 586-599.
- Khan, R. A., Barker, D. E. and Lee, E. M. (1993) Effect of a single *Lernaeocera branchialis* (Copepoda) on growth of Atlantic cod. *Journal of Parasitology* **79**, 954-958.
- Khan, R. A. and Lacey, D. (1986) Effect of concurrent infections of *Lernaeocera branchialis* (Copepoda) and *Trypanosoma murmanensis* (Protozoa) on Atlantic cod, *Gadus morhua*. *Journal of Wildlife Diseases* **22**, 201-208.
- Khan, R. A. and Lee, E. M. (1989) Influence of *Lernaeocera branchialis* (Crustacea: Copepoda) on growth rate of Atlantic cod, *Gadus morhua*. *Journal of Parasitology* **75**, 449-454.
- Khan, R. A., Lee, E. M. and Barker, D. (1990) *Lernaeocera branchialis*: A potential pathogen to cod ranching. *Journal of Parasitology* **76**, 913-917.
- Knaus Knudsen, K. and Sundnes, G. (1998) Effects of salinity on infection with *Lernaeocera branchialis* (L.) (Copepoda: Pennellidae). *Journal of Parasitology* **84**, 700-704.
- Koie, M. (1999) Metazoan parasites of flounder *Platichthys flesus* (L.) along a transect from the southwestern to the northeastern Baltic Sea. *ICES Journal of Marine Science* **56**, 157-163.

- Kurlansky, M. (1998) Cod. A biography of the fish that changed the world. 294pp
- Körner, M. and Haas, W. (1998) Chemo-orientation of echinostome cercariae towards their snail hosts: amino acids signal a low host-specificity. *International Journal for Parasitology* **28**, 511-516.
- Landolt, P.J. and Phillips, T.W. (1997) Host plant influences on sex pheromone behaviour of phytophagous insects. *Annual Review of Entomology* **42**, 371-391.
- Lass, S. and Spaak, P. (2003) Chemically induced anti-predator defences in plankton: a review. *Hydrobiologia* **491**, 221-239.
- Lebedeva, N.E. and Golovkina, T.V. (1994) Fishes natural chemical signals. *Biofizika* **39**, 534-537.
- Lee, E. M. and Khan, R. A. (2000) Length-weight-age relationships, food, and parasites of Atlantic cod (*Gadus morhua*) off coastal Labrador within NAFO Divisions 2H and 2J-3K. *Fisheries Research* **45**, 65-72.
- Lewis, A.G. (1963) Life history of the caligid copepod *Lepeophtheirus dissimulatus*, Wilson, 1905. *Pacific Science* **17**, 195-242.
- Linderby, E. and Thulin, J. (1983) Occurrence and abundance of parasitic copepods on cod along the west and south coast of Sweden. *Proceedings of the 11th Scandinavian Symposium for Parasitology* **17**, 79.
- Loehle, C. (1990) Home range: a fractal approach. *Landscape Ecology* **5**, 39-52.
- Lou, Y. and Cheng, J. (2001) Host-recognition kairomone from *Sogetella furcifera* for the parasitoid *Anagrus nilaparvatae*. *Entomologia Experimentalis et Applicata*

101, 59-67.

Lysne, D.A., Hemmingsen, W. and Skorping, A. (2006) Is reduced body growth of cod exposed to the gill parasite *Lernaeocera branchialis* a cost of resistance? *Journal of Fish Biology* **69**, 1281-1287.

Lysne, D.A. and Skorping, A. (2002) The parasite *Lernaeocera branchialis* on caged cod: infection pattern is caused by differences in host susceptibility. *Parasitology* **124**, 69-76.

Machado Cruz, J.A. (1959) *Lernaeocera caparti* sp. nov., copépode parasite de *Merluccius merluccius* (Linné). *Publicacoes do Instituto de zoologia "Dr. Auguste Nobre" Faculdade de Ciencias Univesidade do Porto* **64**, 7-12.

MacKinnon, B.M. (1993) Response of the copepod larvae of *Caligus elongatus* to light, and the ultrastructure of the eyes. *Canadian Journal of Fisheries and Aquatic Sciences* **50**, 793-799.

Mandelbrot, B.B. (1982) *The Fractal Geometry of Nature*. W. H. Freeman and Company.

Mann, H. (1952) *Lernaeocera branchialis* (Copepoda parasitica) und seine Schadwirkung bei einigen Gadiden. *Archiv fur Fischereiwissenschaft* **4**, 133-144.

Mann, H. (1970) Copepods and isopods as parasites of marine fishes. *A Symposium on Diseases of Fishes and Shellfishes*. S. F. Snieszko (Ed.). American Fisheries Society, Washington, D.C., Special Publication **5**, 177-188.

Markevich, A.P. (1956) Parraziticheskie veslonogie ryb SSSR [Parasitic copepods of

fishes of the USSR.]. *Izvestiya Akademii Nauk Ukraine SSR, Kiev*. 259pp

- Matsuda, H., Hori, M. and Abrams, P.A. (1994) Effects of predator-specific defence on community complexity. *Evolutionary Ecology* **8**, 628-638.
- Metzger, A. (1868) Ueber das Männchen und Weibchen der Gattung *Lernaea* vor den Eintritt der sogenannten rüchschreitenden Metamorphose. Translation in *Annals and Magazine of Natural History* **4**, 154-157.
- Moller, H. (1983) The effects of *Lernaeocera* infestation on cod. *Bulletin of the European Association of Fish Pathologists* **3**, 21-22.
- Moore, P. and Crimaldi, J. (2004) Odor landscapes and animal behavior: tracking odor plumes in different physical worlds. *Journal of Marine Systems* **49**, 55-64.
- Murlis, J., Elkinton, J.S. and Cardé, R.T. (1992) Odor plumes and how insects use them. *Annual Review of Entomology* **37**, 505-532.
- Nihongi, A., Lovern, S.B. and Stickler, J.R. (2004) Mate-searching behaviors in the freshwater calanoid copepod *Leptodiatomus ashlandi*. *Journal of Marine Systems* **49**, 65-74.
- O'Brien, W.J., Evans, B.I. and Brownman, H.I. (1989) Flexible search tactics and efficient foraging in saltatory searching animals. *Oecologia* **80**, 100-110.
- O'Neill, M.A., Gauld, I.D., Gaston, K.J. and Weeks, P.J.D. (2000) DAISY: an automated invertebrate identification system using holistic vision techniques. *Proceedings of the Inaugural Meeting BioNET-INTERNATIONAL Group for Computer-Aided Taxonomy (BIGCAT)* Chesmore, D.; Yorke, L.; Bridge, P; Gallagher, S. (Eds.) pp. 13-22. Egham: BioNET-INTERNATIONAL Technical

Secretariat

- Øines, Ø and Heuch, P. A. (2005) Phylogeny of selected copepods of the family Caligidae, with the emphasis on molecular evidence for a sibling species complex in *Caligus elongatus*. *9th International Conference on Copepoda* July 11-15, 2005, Hammamet, Tunisia p.201.
- Olsen, R.S. (2001) *Lepeophtheirus salmonis*: mechanisms for host identification. PhD Thesis, University of Bergen, Bergen, Norway.
- Olsson, P. (1869) Prodrömus faunae copepodorum parasitantium Scandinaviae. *Acta University Lund* **5**, 1-49.
- Oorde-de Lint, G.M.v. and Schuurmans Stekhoven, J.H. (1936) Copepoda parasitica. *Tierwelt der Nord - und Ostsee, Leipzig* **31**, 73-197.
- Osorio, B. (1892) Appendice ao catalogo dos crustaceos de Portugal existentes no Museu Nacional de Lisboa. *Journal of Science, Mathematics, Physics and Natural History, Lisboa* **2** , 233-241.
- Panikkar, N.K. and Sproston, N.G. (1941) Osmotic relations of some metazoan parasites. *Parasitology* **33**, 214-223.
- Papadogiannakis, N. and Johnsen, S.A. (1987) Motogenic action of phorbol ester TPA and calcium ionophore A23187 on human cord and maternal/adult peripheral lymphocytes: regulation by PGE₂. *Clinical and Experimental Immunology* **70**, 173-181.
- Papadogiannakis, N., Johnsen, S.A. and Olding, L.B. (1984) Stong prostaglandin associated suppression of the proliferation of human maternal lymphocytes by

neonatal lymphocytes linked to T versus T cell interactions and differential PGE₂ sensitivity. *Clinical and Experimental Immunology* **61**, 125-134.

Pedashenko, D.D. (1898) Die Embryonalentwicklung und Metamorphose von *Lernaea branchialis*. *Travaux de la Societe Imperiale des Naturalistes de St. Petersburg* **26**, 247-307.

Perkins, P.S. (1985) Iron crystals in the attachment organ of the erythrophagous copepod *Cardiodectes medusaeus* (Pennellidae). *Journal Crustacean Biology* **5**, 591-605.

Piasecki, W. (1996) The developmental stages of *Caligus elongatus* von Nordmann, 1832 (Copepoda: Caligidae). *Canadian Journal of Zoology* **74**, 1459-1478.

Piasecki, W. and MacKinnon, B.M. (1993) Changes in structure of the frontal filament in sequential developmental stages of *Caligus elongatus* von Nordmann, 1832 (Crustacea, Siphonostomatoida). *Canadian Journal of Zoology* **71**, 889-895.

Piasecki, W. and MacKinnon, B.M. (1995) Life cycle of a sea louse, *Caligus elongatus* von Nordmann, 1832 (Copepoda: Siphonostomatoida, Caligidae). *Canadian Journal of Zoology* **73**, 74-82.

Pike, A.W., MacKenzie, K. and Rowand, A. (1993) Ultrastructure of the frontal filament in chalimus larvae of *Caligus elongatus* and *Lepeoptheirus salmonis* from Atlantic salmon, *Salmo salar*. In: *Pathogens of Wild and Farmed Fish: Sea Lice*. G. A. Boxshall and D. Defaye (Eds.). Ellis Horwood, Chichester, U. K. 99-113.

Pike, A.W., Mordue, A.J. and Ritchie, G. (1993) The development of *Caligus*

- elongatus* Nordmann from hatching to copepodid in relation to temperature. In: *Pathogens of Wild and Farmed Fish: Sea lice*. G. A. Boxshall and D. Defaye (Eds.). Ellis Horwood, Chichester, U. K.
- Pilcher, M.W., Whitfield, P.J. and Riley, J.D. (1989) Seasonal and regional infestation characteristics of three ectoparasites of whiting, *Merlangius merlangus* L. in the North Sea. *Journal of Fish Biology* **35**, 97-110.
- Polyanski, Yu.I. and Kulemina, I.V. (1963) The parasite fauna of young cod from the Barents Sea. *Vestnik Leningradskogo Universiteta, Seriya Biologii* **30**, 174-192.
- Pompanon, F., De Schepper, B., Mourer, Y., Fouillet, P. and Bouletreau, M. (1997) Evidence for substrate-borne sex pheromone in the parasitoid wasp *Trichogramma brassicae*. *Journal of Chemical Ecology* **23**, 1349-1360.
- Potter, I.C., Gardner, D.C. and Claridge, P.N. (1988) Age composition, growth, movements, meristics and parasites of the whiting, *Merlangius merlangus*, in the Severn Estuary and Bristol Channel. *Journal of the Marine Biological Association of the UK* **68**, 295-313.
- Purcell, J.E. and Anderson, P.A.V. (1995) Electrical responses to water-soluble components of fish mucus recorded from the cnidocytes of a fish predator. *Marine and Freshwater Behavioural Physiology* **26**, 149-162.
- Radulescu, I.I., Nalbant, T.T. and Angelescu, N. (1972) Noi contributii la cunoasterea parazitofaunei pestilar din Oceane Atlantic. *Buletinul de Cercetari Piscicole* **31**, 71-78.

- Reed, G.B. and Dymond, J.R. (1951) Report Newfoundland Fisheries Station. *Report of the Fisheries Research Board of Canada*, 43-65.
- Reichstein, T., von Euw, J., Parsons, J.A. and Rothschild, M. (1968) Heart poisons in the monarch butterfly. *Science* **161**, 861-866.
- Ridley, P., Howse, P.E. and Jackson, C.W. (1996) Control of the behaviour of leaf-cutting ants by their 'symbiotic' fungus. *Cellular and Molecular Life Sciences* **52**, 631-635.
- Ritchie, G., Mordue (Luntz), A.J., Pike, A.W. and Rae, G.H. (1996) Observations on mating and reproductive behaviour of *Lepeophtheirus salmonis*, Krøyer (Copepoda: Caligidae). *Journal of Experimental Marine Biology and Ecology* **201**, 285-298.
- Rittschof, D. and Cohen, J.H. (2004) Crustacean peptide and peptide-like pheromones and kairomones. *Peptides* **25**, 1503-1516.
- Rose, M. and Hamon, M. (1953) Apropos de *Penella varians* Steenstrup & Lütken, 1861, parasite des branchies de céphalopodes. *Bulletin de la Société d'Histoire Naturelle de l'Afrique du Nord* **44**, 172-183.
- Rose, M. and Hamon, M. (1952) Sur un copépode parasite de certains mollusques ptéropodes thééosomes. *Annals of Nature and Zoology* **14**, 219-230.
- Rose, R.M., Warne, M.St.J. and Lim, R.P. (2001) Factors associated with fish modify life history traits of the cladoceran *Ceriodaphnia cf. dubia*. *Journal of Plankton Research* **23**, 11-17.
- Ross, N.W., Firth, K.J., Wang, A., Burka, J.F. and Johnson, S.C. (2000) Changes in

- hydrolytic enzyme activities of naive atlantic salmon *Salmo salar* skin mucus due to infection with the salmon louse *Lepeophtheirus salmonis* and cortisol implantation. *Diseases of aquatic organisms* **41**, 43-51.
- Ruther, J., Meiners, T. and Steidle, L.M. (2002) Rich in phenomena-lacking in terms. A classification of karimones. *Chemoecology* **12**, 161-167.
- Sanchez-Lizaso, J.L.V.J. (1987) Infestation of cod by *Lernaeocera branchialis* in ICES Division IIb. *ICES C.M. 1987/G:6* 6pp
- Sandau, K. and Kurz, H. (1996) Measuring fractal dimension and complexity - an alternative approach with an application. *Journal of Microscopy* **186**, 164-176.
- Schram, T.A. (1979) The life history of the eye-maggot of the sprat, *Lernaeenicus sprattae* (Sowerby) (Copepoda, Lernaeoceridae). *Sarsia* **64**, 279-316.
- Schram, T.A. and Heuch, P.A. (2001) The egg string attachment mechanism of selected pennellid copepods. *Journal of the Marine Biological Association of the UK* **81**, 23-32.
- Schuermans Stekhoven, J.H. (1936) Copepoda parasitica from the Belgian coast, II. (Included some habitats in the North Sea). *Memoires de Musee Royal D'Histoire Naturelle de Belgique* **74**, 1-20.
- Schuermans Stekhoven, J.H.J. (1936) Beobachtungen zur Morphologie und Physiologie der *Lernaeocera branchialis* L. und der *Lernaeocera lusci* Bassett-Smith (Crustacea parasitica). *Zeitschrift fur Parasitenkunde* **8**, 659-698.
- Schuermans Stekhoven, jr.J.H. and Punt, A. (1937) Weitere Beitrage zur Morphologie und Physiologie der *Lernaeocera branchialis* L. *Zeitung fur Parasitenkunde* **9**,

648-668.

Scott, A. (1901) *Lepeophtheirus* and *Lernaea*. *Liverpool Marine Biology Committee Memoirs* **6**, 54pp

Seuront, L., Hwang, J.S. and Tseng, L.C. (2004) Individual variability in the swimming behaviour of the sub-tropical copepod *Oncaea venusta* (Copepoda: Poecilostomatoida). *Marine Ecology Progress Series* **283**, 199-217.

Seuront, L., Schmitt, F.G., Brewer, M.C., Strickler, J.R. and Souissi, S. (2004) From random walk to multifractal random walk in zooplankton swimming behaviour. *Zoological studies* **43**, 498-510.

Seuront, L., Yamazaki, H. and Souissi, S. (2004) Hydrodynamic disturbance and zooplankton swimming behaviour. *Zoological Studies* **43**, 376-387.

Sherman, K. and Wise, J. P. (1961) Incidence of the cod parasite *Lernaeocera branchialis* L. in the New England area, and its possible use as an indicator of cod populations. *Limnology and Oceanography* **6**, 61-67.

Shotter, R.A. (1973a) Changes in the parasite fauna of whiting, *Odontogadus merlangus* (L.) with age and sex of host, season, and from different areas in the vicinity of the Isle of Man. *Journal of Fish Biology* **5**, 559-573.

Shotter, R.A. (1973b) A comparison of the parasite fauna of the young whiting, *Odontogadus merlangus* (L.)(Gadidae) from an inshore and an offshore location off the Isle of Man. *Journal of Fish Biology* **5**, 185-195.

Shotter, R.A. (1976) The distribution of some helminth and copepod parasites in tissues of whiting, *Merlangus merlangius* L., from Manx waters. *Journal of Fish*

Biology **8**, 101-117.

- Shulman, S.S. and Shulman-Albova, R.E. (1953) Parazity ryb Belogo Morya. [Parasites of fishes of the White Sea.]. *Izvestiya Akademii Nauk SSSR, Moscow and Leningrad* 199pp.
- Smith, J. A. and Whitfield, P. J. (1988) Ultrastructural studies on the early cuticular metamorphosis of adult female *Lernaeocera branchialis* (L.) (Copepoda, Pennellidae). *Hydrobiologia* **167**, 607-616.
- Smith, J.L., Wootten, R. and Sommerville, C. (2007) The pathology of the early stages of the crustacean parasite, *Lernaeocera branchialis* (L.), on Atlantic cod, *Gadus morhua* L. *Journal of Fish Diseases* **30**, 1-11.
- Smith, J.W. (1969) The distribution of one monogenean and two copepod parasites of whiting, *Merlangius merlangus* (L.) caught in British waters. *Nytt Magasin for Zoologi* **17**, 57-63.
- Soddell, J. and Seviour, R. (1995) Using box counting techniques for measuring shape of colonies of filamentous micro-organisms. *Computing International* http://journal-ci.csse.monash.edu.au//ci/vol02/j_soddell/j_soddell.html Date of access: 2007.
- Sproston, N.G. (1942) The developmental stages of *Lernaeocera branchialis*. *Journal of the Marine Biological Association of the UK* **25**, 441-446.
- Sproston, N.G. and Hartley, P.H.T. (1941a) The ecology of some parasitic copepods of gadoids and other fishes. *Journal of the Marine Biological Association of the UK* **25**, 361-392.

- Sproston, N.G. and Hartley, P.H.T. (1941b) Observations on the bionomics and physiology of *Trebius caudatus* and *Lernaeocera branchialis* (Copepoda). *Journal of the Marine Biological Association of the UK* **25**, 393-417.
- Sreenivasan, K.R., Prasad, R.R. and Menavau, C. (1989) The fractal geometry of interfaces and the multifractal distribution of dissipation in fully turbulent flows. In: *Fractals in Geophysics* Scholz, C. H.; Mandelbrot, B. B. (Eds.) pp. 43-60. Basel: Birkäuser
- Stevenson, S.C. and Baird, J.W. (1988) *The fishery for lumpfish (Cyclopterus lumpus) in Newfoundland waters Report No. 1595*, Canadian Technical Report of Fisheries and Aquatic Science.
- Strickler, J.R. (1985) Feeding currents in calanoid copepods: two new hypotheses. In: *Physiological Adaptations of Marine Animals* Laverack, M. S. (Ed.) pp. 459-485. Symposium of the Society of Experimental Biology
- Strickler, J.R. (1998) Observing free-swimming copepods mating. *Philosophical Transactions of the Royal Society Series B* **353**, 671-680.
- Strickler, J.R. and Bal, A.K. (1973) Setae of the first antennae of the copepod *Cyclops scutifer* (Sars): their structure and importance. *Proceedings of the National Academy of Science U.S.A.* **70**, 2656-2659.
- Sundnes, G. (1970) *Lernaeocera branchialis* (L.) on cod (*Gadus morhua* L.) in Norwegian waters. *Institute of Marine Research, Bergen* 48pp
- Sundnes, G., Mork, J., Solemdal, P. and Solemdal, K. (1997) *Lernaeocera branchialis* (L., 1767) on cod in Baltic waters. *Helgolander Meeresuntersuchungen* **51**,

191-196.

- Takacs, S., Gries, G. and Gries, R. (1997) Semiochemical-mediated location of host habitat by *Apanteles carpatus* say Hymenoptera: Braconidae, a parasitoid of clothes moth larvae. *Journal of Chemical Ecology* **23**, 459-472.
- Templeman, W. and Fleming, A. M. (1963) Distribution of *Lernaeocera branchialis* (L.) on cod as an indicator of cod movements in the Newfoundland area. *ICNAF Special Publication* **4**, 318-322.
- Templeman, W., Hodder, V. M. and Fleming, A. M. (1976) Infection of lumpfish (*Cyclopterus lumpus*) with larvae and of Atlantic cod (*Gadus morhua*) with adults of the copepod, *Lernaeocera branchialis*, in and adjacent to the Newfoundland area, and inferences therefrom on inshore-offshore migrations of cod. *Journal of the Fisheries Research Board of Canada* **33**, 711-731.
- Tirard, C., Berrebi, P., Raibaut, A. and Renaud, F. (1993) Biodiversity and biogeography in heterospecific teleostean (Gadidae) - copepod (*Lernaeocera*) associations. *Canadian Journal of Zoology* **71**, 1639-1645.
- Tiselius, P. and Jonsson, P.R. (1990) Foraging behaviour of six calanoid copepods: observations and hydrodynamic analysis. *Marine Ecology Progress Series* **66**, 23-33.
- To, S.S.T. and Schrieber, L. (1990) Effect of leukotriene B₄ and prostaglandin E₂ on the adhesion of lymphocytes to endothelial cells. *Clinical and Experimental Immunology* **81**, 160-165.
- Torto, B., Obeng-Ofori, D., Njag, P.G.N., Hassanali, A. and Amiani, H. (1994)

- Aggregation pheromone system of adult gregarious desert locust *Schistocerca gregaria* (Forsk.) *Journal of Chemical Ecology* **20**, 1749-1762.
- Tsuda, A. and Miller, C.B. (1998) Mate-finding behaviour in *Calanus marshallae*. *Philosophical Transactions of the Royal Society Series B* **353**, 713-720.
- Turchin, P. (1996) Fractal analyses of animal movement: a critique. *Ecology* **77**, 2086-2090.
- Uchima, M. and Murano, M. (1988) Mating behaviour of the marine copepod *Oithonadavisae*. *Marine Biology* **99**, 39-45.
- Uttieri, M., Nihongi, A., Mazzocchi, M.G., Strickler, J.R. and Zambianchi, E. (2007) Pre-copulatory swimming behaviour of *Leptodiaptomus ashlandi* (Copepoda: Calanoida): a fractal approach. *Journal of Plankton Research* **29**, i17-i26
- Uttieri, M., Zambianchi, E. and Strickler, J.R. (2005) Fractal characterization of three-dimensional zooplankton swimming trajectories. *Ecological Modelling* **185**, 51-63.
- Van Damme, P.A. and Ollevier, F. (1995) Morphological and morphometric study of crustacean parasites within the genus *Lernaeocera*. *International Journal for Parasitology* **25**, 1401-1411
- Van Damme, P. A., Geets, A. and Hamerlynck, O. (1997) The suprapopulation dynamics of *Lernaeocera branchialis* and *L. lusci* in the Oosterschelde: seasonal abundance on three definitive host species. *ICES Journal of Marine Science* **54**, 24-31.
- Van Damme, P. A. and Hamerlynck, O. (1992) The infection dynamics and dispersion

- pattern of *Lernaeocera branchialis* L. on 0+ whiting (*Merlangius merlangus* L.) in the Oosterschelde (SW Netherlands). *Journal of Fish Biology* **41**, 265-275.
- Van Damme, P. A., Ollevier, F. and Hamerlynck, O. (1994) Pathogenicity of *Lernaeocera lusci* and *L. branchialis* in bib and whiting in the North Sea. *Diseases of Aquatic Organisms* **19**, 61-65.
- Van den Broek, W.L.F. (1977) Aspects of the biology of fish populations from the Medway Estuary, based on power station intake sampling, with special reference to parasitism and pollution. *Ph.D. Thesis, University of London*.
- Van den Broek, W.L.F. (1978) The effects of *Lernaeocera branchialis* on the *Merlangius merlangus* population in the Medway estuary. *Journal of Fish Biology* **13**, 709-715.
- Van den Broek, W.L.F. (1979a) Copepod ectoparasites of *Merlangius merlangus* and *Platichthys flesus*. *Journal of Fish Biology* **14**, 371-380.
- Van den Broek, W.L.F. (1979b) Infection of estuarine populations by *Lernaeocera branchialis* and its effect on whiting *Merlangius merlangus*. *New Zealand Journal of Zoology* **6**, 646-647.
- Van Duren, L.A. and Videler, J.J. (1995) Swimming behaviour of developmental stages of the calanoid copepod *Temora longicornis* at different food concentrations. *Marine Ecology Progress Series* **126**, 153-161.
- Van Duren, L.A. and Videler, J.J. (1996) The trade-off between feeding, mate seeking and predator avoidance in copepods: behavioural responses to chemical cues.

Journal of Plankton Research **18**, 805-818.

- Van Gool, E. and Ringelberg, J. (2002) Relationship between fish kairomone concentration in a lake and phototactic swimming by *Daphnia*. *Journal of Plankton Research* **24**, 713-721.
- Vazquez, J., Paz Canalejo, X. and G. Escalante, J. L. (1988) Rates of infestation of cod by *Lernaeocera branchialis* in ICES Division IIb. *ICES C. M. 1988/G:2, Session O* 9pp
- Voss, R.F. (1993) Fractals in nature: from characterization to simulation. In: *The Science of Fractal Images*, Peitgen, H.O. and Saupe, D. (Eds.) pp. 265-278. New York: Springer
- Weissburg, M.J., Doall, M.H. and Yen, J. (1998) Following the invisible trail: kinematic analysis of mate-tracking in the copepod *Temora lonicornis*. *Philosophical Transactions of the Royal Society Series B* **353**, 701-712.
- Westerberg, H. (1982) Ultrasonic tracking of Atlantic salmon (*Salmo salar* L.) I. Movements in coastal regions. *Report of the Institute of Freshwater Research Drottningholm* **60**, 81-101.
- Wheeler, Q.D. (2004) Taxonomic triage and the poverty of phylogeny. *Philosophical Transactions of the Royal Society London Series B* **359**, 571-583.
- Whitfield, P.J., Pilcher, M.W., Grant, H.J. and Riley, J. (1988) Experimental studies on the development of *Lernaeocera branchialis* (Copepoda, Pennellidae) - population processes from egg production to maturation on the flatfish host. *Hydrobiologia* **167**, 579-586.

- Wijesekera, H.W. (1996) Fractal dimension as an indicator for turbulent mixing in the thermocline. *Journal of Geophysical Research* **101**, 703-709.
- Wilson, C.B. (1917) North American parasitic copepods belonging to Lernaeidae, with a revision of the entire family. *Proceedings of the United States National Museum* **53**, 1-150.
- Yen, J., Weissburg, M.J. and Doall, M.H. (1998) The fluid physics of signal perception by mate-tracking copepods. *Philosophical Transactions of the Royal Society Series B* **353**, 713-720.

Appendix A

The macro employed in the KS300 software to prepare an image set for track digitisation in the Paratrack software.

```
imgdelete "*"
Gclear 0

file = "enter filename"
read file, "enter experiment name"
read n, "Enter number of images to be analysed"
imgsetpath "C:\ParasiteTracking"
blank = file + "_0.bmp"
imgload blank,2
median 2,2,3

for il=1,il <= n,il = il+1

pic = file + "_" + string(il) + ".bmp"
imgload pic,1
median 1,1,3
shadcorr 1,2,3,1,255

dislevrgb 3,4,1,0,0,255,107,225,11,255,10,"HLS"
binscrap 4,5,1,1,0
showwindow "Display",1
Gextract 4,255,255,10
Gextract 5,255,255,10
Gmerge 1,255
Gclear 0

dislev 3,6,111,225,1
binscrap 6,7,1,1,0
showwindow "Display",1
Gextract 6,255,255,10
Gextract 7,255,255,10
Gmerge 1,255
Gclear 0

disdyn 3,8,3,-15,1
binscrap 8,9,1,1,0
showwindow "Display",1
Gextract 8,255,255,10
Gextract 9,255,255,10
Gmerge 1,255
Gclear 0

pic = file + "_corrected_" + string(il) + ".bmp"
imgsave 1,pic

endfor
```

Appendix B

A list of the parameters calculated in Paratrack and their associated formulae:

Time spent in mixed zone – The time spent in the mixed zone of the choice chamber arena as a percentage of the total experiment time.

$$(\text{time in mixed zone (secs)} / \text{total experiment time (secs)}) * 100$$

Time spent in cue zone – The time spent in the cue zone of the choice chamber arena as a percentage of the total experiment time.

$$(\text{time in cue zone (secs)} / \text{total experiment time (secs)}) * 100$$

Time spent in control zone - The time spent in the control zone of the choice chamber arena as a percentage of the total experiment time.

$$(\text{time in control zone (secs)} / \text{total experiment time (secs)}) * 100$$

Number of periods in mixed zone – The number of periods spent in the mixed zone of the choice chamber arena. A period begins when the parasite enters the zone and ends when the parasite leaves the zone.

Number of periods in cue zone - The number of periods spent in the cue zone of the choice chamber arena. A period begins when the parasite enters the zone and ends when the parasite leaves the zone.

Number of periods in control zone - The number of periods spent in the control zone of the choice chamber arena. A period begins when the parasite enters the zone and ends when the parasite leaves the zone.

Length of period in mixed zone – The mean length of a period in the mixed zone of the choice chamber arena in seconds. A period begins when the parasite enters the zone and ends when the parasite leaves the zone.

time in mixed zone (secs) / number of periods in mixed zone

Length of period in cue zone – The mean length of a period in the cue zone of the choice chamber arena in seconds. A period begins when the parasite enters the zone and ends when the parasite leaves the zone.

time in cue zone (secs) / number of periods in cue zone

Length of period in control zone – The mean length of a period in the control zone of the choice chamber arena in seconds. A period begins when the parasite enters the zone and ends when the parasite leaves the zone.

time in control zone (secs) / number of periods in control zone

Velocities – A list of the velocities of the parasite during the experiment between each consecutive pair of video frames in mm / sec.

Distance travelled between consecutive pair of frames (mm) * frame rate (frames / sec)

Mean velocity – The mean velocity of the parasite during the experiment in mm / second.

distance travelled during experiment (mm) / total experiment time (secs)

Maximum velocity – The maximum velocity of the parasite recorded in the experiment between two consecutive video frames in mm / second.

distance travelled between frames (mm) * frame rate (frames / sec)

Distance travelled – The total distance travelled by the parasite during the experiment in cm. Calculated by summing the distance travelled by the parasite between each consecutive pair of video frames for all the frames in an experiment.

Time spent moving – The total time spent moving by the parasite during an experiment in seconds. Movement is defined as different parasite co-ordinates in a video frame compared to the parasite co-ordinates in the previous video frame.

number of frames where movement occurred * frame rate (frames / sec)

Time spent immobile – The total time spent immobile by the parasite during an experiment in seconds. Immobility is defined as identical parasite co-ordinates in two consecutive video frames.

number of frames where immobility occurred * frame rate (frames / sec)

Number of swimming bouts – The number of swimming bouts made by the parasite during an experiment. A swimming bout begins when movement is detected (Movement is defined as different parasite co-ordinates in a video frame compared to the parasite co-ordinates in the previous video frame) and ends when immobility is detected (Immobility is defined as identical parasite co-ordinates in two consecutive video frames).

Duration of swimming bouts – The mean duration of a swimming bout made by the parasite in seconds.

time spent moving (secs) / number of swimming bouts

Mean distance travelled during swimming bouts – The mean distance travelled by the parasite during each swimming bout in cm.

$$\text{total distance travelled (cm) / number of swimming bouts}$$

Mean velocity during swimming bouts – The mean velocity of the parasite during swimming bouts in mm / second.

$$\text{Total distance travelled (mm) / time spent moving (secs)}$$

Number of immobile bouts - The number of immobile bouts made by the parasite during an experiment. An immobile bout begins when immobility is detected (Immobility is defined as identical parasite co-ordinates in two consecutive video frames) and ends when movement is detected (movement is defined as different parasite co-ordinates in a video frame compared to the parasite co-ordinates in the previous video frame).

Duration of immobile bouts - The mean duration of an immobile bout made by the parasite in seconds.

$$\text{time spent immobile (secs) / number of immobile bouts}$$

Headings – A list of the headings (angle from 0°) of the parasite during the experiment in degrees. Calculated by measuring the angle of trajectory by the parasite between each pair of consecutive video frames for all the frames in an experiment.

Mean heading – The mean heading of the parasite during the experiment in degrees.

$$\text{sum of all headings (degrees) / total number of frames}$$

Turn rate – The mean rate of turning by the parasite during the experiment in degrees / second. Turn is measured for each consecutive pair of frames by calculating the deviation (in degrees) from the parasite's heading in the previous frame.

$$\text{sum of all turning (degrees) / total experiment time (secs)}$$

Meander – The mean meander (rate of turning per unit of distance) by the parasite during the experiment in degrees / mm. Turn is measured for each consecutive pair of frames by calculating the deviation (in degrees) from the parasite's heading in the previous frame.

$$\text{sum of all turning (degrees) / total distance travelled (mm)}$$