

Loughborough University
Institutional Repository

*A framework for modelling
embodied product energy to
support energy efficient
manufacturing*

This item was submitted to Loughborough University's Institutional Repository by the/an author.

Additional Information:

- A Doctoral Thesis. Submitted in partial fulfillment of the requirements for the award of Doctor of Philosophy of Loughborough University.

Metadata Record: <https://dspace.lboro.ac.uk/2134/8766>

Publisher: © Yingying Seow

Please cite the published version.

This item was submitted to Loughborough's Institutional Repository (<https://dspace.lboro.ac.uk/>) by the author and is made available under the following Creative Commons Licence conditions.



CC creative commons
COMMONS DEED

Attribution-NonCommercial-NoDerivs 2.5

You are free:

- to copy, distribute, display, and perform the work

Under the following conditions:

BY: **Attribution.** You must attribute the work in the manner specified by the author or licensor.

Noncommercial. You may not use this work for commercial purposes.

No Derivative Works. You may not alter, transform, or build upon this work.

- For any reuse or distribution, you must make clear to others the license terms of this work.
- Any of these conditions can be waived if you get permission from the copyright holder.

Your fair use and other rights are in no way affected by the above.

This is a human-readable summary of the [Legal Code \(the full license\)](#).

[Disclaimer](#) 

For the full text of this licence, please go to:
<http://creativecommons.org/licenses/by-nc-nd/2.5/>



**A Framework for Modelling
Embodied Product Energy to Support
Energy Efficient Manufacturing**

by

Yingying Seow

A Doctoral Thesis

*Submitted in partial fulfilment of the requirements
for the award of
Doctor of Philosophy of Loughborough University*

May 2011

© by Yingying Seow, 2011

Acknowledgments

I would like to express my sincere gratitude to my supervisor Professor Shahin Rahimifard for providing constant guidance, support and motivation throughout the course of this research without which this research would not have been possible. Thank you for all the stories and words of wisdom along this journey.

I am also thankful for my colleagues, Eileen Wright who provided many constructive suggestions during the writing of this thesis, Dr. Elliot Woolley for helping with the proof reading and edits to this thesis, Dr. Mike Lee, James Colwill and Madhu Sachidananda for providing much laughter and interesting discussions from the most trivial of topics to serious ones like sustainability.

Also to Eujin, Noor, Minna, Aparna and the many other wonderful friends whom I've met over this period, thank you for filling my evenings and weekends with charming company, great food, hilarious games, awesome parties and a treasure trove of fond memories which will be dearly cherished.

Finally, I dedicate this thesis to my family. To my Mum and Dad for their endless faith and support all these years and my sisters who provided company during the late nights despite being many miles away.

Synopsis

This thesis reports on the research undertaken to minimise the energy consumption within the production phase of a product life cycle through modelling, monitoring and improved control of energy use within manufacturing facilities. The principle objective of this research is to develop a framework which integrates energy consumption data at the ‘plant’ and ‘process’ perspectives within a manufacturing system so as to be able to indicate how much energy is required to manufacture a unit product.

The research contributions are divided into four major parts. The first part reviews the relevant literature in energy trends, related governmental policies and legislative measures, and their impact on industry. Various energy management and modelling tools and software have also been identified and reviewed. The second part introduces an ‘Embodied Product Energy’ framework which categorises the energy consumption within a production facility into ‘direct’ and ‘indirect’ energy required to manufacture a product. Direct energy is defined as the energy consumed by the production processes, whereas the indirect energy is the energy required to maintain the environment in which the production takes place. The third part describes the design and implementation of a simulation model based on this framework to support manufacturing and design decisions for improved energy efficiency through the use of ‘what-if’ scenario planning. The final part of the thesis outlines the utilisation of this energy simulation model to support a ‘Design for Energy Minimisation’ methodology which aims to incorporate energy considerations within the design process to minimise the energy required to manufacture a product.

The applicability of the proposed research concepts have been demonstrated via two case studies. The detailed analysis of energy consumption from a product viewpoint provides greater insight into the inefficiencies of the processes and associated supporting activities, thereby highlighting opportunities for optimisation of energy consumption via operational or design improvements. Although the research domain for this thesis is limited to the production phase, the flexibility offered by the energy modelling framework and associated simulation tool allow for their employment to other stages of a product life cycle.

In summary, the research has concluded that investment in green sources of power generation alone is insufficient to deal with the rapid rise in energy demand, and has highlighted the paramount importance of energy rationalisation and optimisation within the manufacturing industry.

Abbreviations

ABS	Acrylonitrile-Butadiene-Styrene
AE	Auxiliary Energy
AEMS	Advanced Energy Management System
CCA	Climate Change Agreements
CCL	Climate Change Levy
CH ₄	Methane
CO ₂	Carbon Dioxide
CRC	Carbon Reduction Commitment
DE	Direct Energy
DfEM	Design for Energy Minimisation
DfA	Design for Assembly
DfE	Design for Environment
DfM	Design for Manufacture
DfX	Design for 'X'
EPE	Embodied Product Energy
ER	Efficiency Ratio
EMS	Energy Management Systems
ESM	Energy Simulation Model
HVAC	Heating Ventilation Air-Conditioning
HOQ	House of Quality
IE	Indirect Energy
KERS	Kinetic Energy Recovery Systems
LCA	Life Cycle Assessment
LCEA	Life Cycle Energy Analysis
LCI	Life Cycle Inventory
OEM	Original Equipment Manufacturer
PDS	Product Design Specification
PP	Polypropylene
SEC	Specific Energy Consumption
SEP	Superior Energy Performance
S-LCA	Streamlined Life Cycle Assessment
TE	Theoretical Energy

The typical units of energy and their Joules equivalent are shown below:

Unit	Equivalent amount	Representation
British thermal unit (typically used for measuring gas)	1055 J	1 Btu
Kilowatt hour - Multiplication of power in watt and time in hours (billing unit for energy delivered to consumers by electric utilities)	3,600,000 J or 3.6 MJ	1 kwh
Barrels of oil equivalent	6,000,000,000 J or 6 GJ	1 boe
Tonne of oil equivalent	41,868,000,000 J or 41.9 GJ	1 toe
Tonnes of coal equivalent	29,000,000,000 J or 29 GJ	1 tce
Watt - Unit of power and measures the rate of energy consumption	1 joule/sec	1 w

While the units used in this thesis are generally accepted within the field of energy analysis that do not necessarily conform to the International System of Units (SI) which include: meters (m), kilograms (kg), seconds (s), and degrees Kelvin (K). Units which are not SI units include tonnes (t), British Thermal units (BTU) and Joules (J). The following stand metric prefixes were also used:

prefix	abbreviation	multiple	Description
milli	(m)	10^{-3}	(thousandth)
kilo	(k)	10^3	thousand
mega	(M)	10^6	million
giga	(G)	10^9	billion
peta	(P)	10^{15}	million billion
exa	(E)	10^{18}	billion billion

List of Figures

Figure 1.1: The three different perspectives used to assess energy consumption within a manufacturing system- Plant, Process and Product Viewpoint	2
Figure 1.2: Overview of the thesis structure	5
Figure 3.1: World energy demand by region. (IEA, 2008a)	15
Figure 3.2: World primary energy demand by fuel (IEA, 2009)	16
Figure 3.3: Observed changes in (a) global average surface temperature; (b) global average sea level from tide gauge (blue) and satellite (red) data; and (c) Northern Hemisphere snow cover for March-April (IPCC, 2007a)	24
Figure 3.4: Electricity consumption (Mtoe) by sector between 1971 to 2008 (IEA, 2010a).....	28
Figure 3.5: Electricity generation (TWh) by fuel type from 1971 to 2008 (IEA, 2010a).....	28
Figure 3.6: Energy use by sector from 1990 to 2050. (IEA, 2008).....	30
Figure 3.7: Shares of global final energy consumption and carbon emissions by sector, 2005 (adapted from IEA, 2008a)	30
Figure 3.8: Final energy consumption of various sectors (UK) in primary energy equivalent in 2007	31
Figure 3.9: Electricity consumption of various sectors (UK) in primary energy equivalent in 2007	32
Figure 3.10: Energy use within industry by type of use in 2009 (BERR, 2009)	32
Figure 3.11: Long-term energy savings from improvements in energy efficiency (IEA, 2008b).....	34
Figure 4.1: Complexity and difficulty of assessing energy within an industrial system (Herrmann <i>et al.</i> 2007)	39
Figure 4.2: Energy flows at various stages of the life cycle (Fay <i>et al.</i> , 2000).....	43
Figure 4.3: The different levels within a manufacturing system and the respective areas of research commonly conducted.....	46
Figure 4.4: Level of analysis of manufacturing with temporal decision scales	47
Figure 4.5: Optimization decisions for production process planning in terms of sustainable evaluation (Tan <i>et al.</i> , 2006).....	51
Figure 4.6: Machining energy use breakdown for various automated milling machine (adapted from Dahmus and Gutowski, 2004).....	54
Figure 4.7: Energy analysis of four milling machines (Dahmus and Gutowski, 2004).....	55

Figure 4.8: Relative energy consumption per production mode (Devoldere <i>et al.</i> , 2007).....	56
Figure 4.9: Determination of power characteristics and energy requirements of machine tools (Kalla <i>et al.</i> , 2009).....	59
Figure 4.10: Electrical energy consumption of a grinding process (Herrmann <i>et al.</i> , 2008).....	60
Figure 4.11: Energy load profile of the machining process over time with the respective events detailed in Table 4.6.....	61
Figure 4.12: Work in form of electricity used per unit of material processed for various manufacturing processes as a function of the rate of material processing (Gutowski <i>et al.</i> , 2009).....	66
Figure 4.13: Load profile during a representative period of operation (Muller and Loffler, 2010).....	68
Figure 4.14: Energy related activities within the planning process and management of energy related data (Muller and Loffler, 2010).....	68
Figure 4.15: Resulting data volume from 64-bit measurement values depending on its temporal resolution (ranging from 1.5 min up to 10 ms) from a single data output. (Hermann <i>et al.</i> , 2010).....	69
Figure 4.16: Examples of analysis across various levels. (Vijayaraghavan and Dornfeld, 2010).....	70
Figure 4.17: Unified monitoring scheme using MTConnect (Diaz <i>et al.</i> , 2009).....	71
Figure 4.18: Taxonomy of Processes used by CO2PE (UPLCI, 2010).....	72
Figure 4.19: Operational cooperative scheme for data collection and analysis (Duflou, 2009).....	73
Figure 6.1: Outline of research methodology.....	86
Figure 7.1: EPE represented by Plant and Process activities in a Product Viewpoint.....	91
Figure 7.2: Integration of energy information from each of the 'plant', 'process' and 'product' perspective into a singular energy database.....	92
Figure 7.3: Overview of the framework showing the IE and the DE.....	93
Figure 7.4: Manufacturing process of an elbow pipe.....	94
Figure 7.5: Direct energy required to manufacture an elbow pipe.....	95
Figure 7.6: Indirect energy required to manufacture an elbow pipe.....	96
Figure 7.7: Total Embodied Product Energy of elbow pipe.....	97
Figure 8.1: Overview of energy the Embodied Product Energy framework.....	100
Figure 8.2: Establishing the data collection method for TE, AE and IE.....	102
Figure 8.3: The Chauvin Arnoux C.A 8335 Qualistar Plus and the graphical outputs when used with the Dataviewer Pro.....	103

Figure 8.4: A Chauvin Arnoux data logger recording energy data off a load centre	104
Figure 8.5: Power profile graph show with the area under the graph in green denoting the TE and the yellow are denoting AE.....	104
Figure 8.6: Calculating Direct Energy is the sum of all TE and the AE for the processes required to manufacture Product <i>A</i>	109
Figure 8.7: IE is attributed to the product based on the zone it is produced in.....	111
Figure 8.8: A graphical representation of the EPE framework showing the sum of the TE, AE and IE to establish the embodied product energy of Product <i>A</i>	112
Figure 8.9: Graphical plot of the process efficiency ratios for <i>n</i> processes	115
Figure 8.10: Graphical plot of the product efficiency ratios for <i>n</i> products.....	116
Figure 8.11: Graphical plot of the plant efficiency ratios for <i>n</i> manufacturing systems.....	117
Figure 9.1: Inputs and outputs from the simulation model	119
Figure 9.2: The model can help with understanding the impact of different batch sizes on embodied energy per product.	120
Figure 9.3: Overview of simulation window in Arena showing the different modelling modules and features	122
Figure 9.4: Entering data directly into the model through the use of the ‘Assign’ Module.....	123
Figure 9.5: Using MS Excel to store the data and exporting the data into Arena.....	124
Figure 9.6: Data on the casting process is entered in the model through the ‘Assign’ module as attributes	125
Figure 9.7: Calculating the TE and AE for the casting process using the ‘Assign’ module to specify an equation	127
Figure 9.8: Specifying the process time within the ‘Process’ module. The process time can be expressed as a constant value or as a statistical or mathematical expression.....	129
Figure 9.9: The Assign module can be used to denote the IE equation which records the time a product spends in a process	129
Figure 9.10: Using the create module to set the number of batches as well as different batch sizes.....	130
Figure 9.11: Process flow created for the Elbow pipe using the four main Arena modules.....	131
Figure 9.12: The simulation model for the elbow pipe showing the top level simulation window along with the sub model windows with the data input and calculations for each process	132
Figure 9.13: The output of the simulation model, the values for TE, AE and IE are displayed alongside the efficiency ratios.....	133

Figure 9.14: An example of the process energy chart showing plot of TE, AE and IE for each entity in Process 1. Numerical value at the top indicates the average energy consumed.....	135
Figure 9.15: Chart showing average embodied energy by process. $ER_{process}$ for each process are plotted on the secondary axis.....	135
Figure 9.16: Overview of the energy graphs in Excel a) Process Energy Charts, b) Efficiency Ratio Charts, c) Chart of EPE for each product over time,.....	136
Figure 9.17: The application of energy simulation model to aid operational improvements and product design.....	137
Figure 10.1: The determination and generation of environmental impacts in a product's life cycle (Rebitzer, 2002).....	138
Figure 10.2: The three main design stages - concept design, detail design and manufacture as proposed by Pugh (1991)	139
Figure 10.3: The evolution of design tools over time	141
Figure 10.4: DfEM considerations across the life cycle phases and design phases.....	142
Figure 10.5: DfEM tools for the production phase	143
Figure 10.6: Streamlined Life Cycle Assessment can be conducted through the use of software such as CES EcoSelector	145
Figure 10.7: The Energy Simulation Model can help with process parameter selection, machine selection and facility services selection	146
Figure 10.8: Advanced Energy Metering systems to track energy use of processes and equipment in a manufacturing facility.....	147
Figure 10.9: Application of various tools in a product design process to aid energy minimisation.....	149
Figure 10.10: An example of a database model structure to store and organise energy data	151
Figure 10.11: The model in Arena (top) with data output in Excel (bottom) showing the average EPE for a batch of products.....	152
Figure 10.12: HOQ based design support tool for Energy minimisation of the production phase against common design specifications	155
Figure 10.13: Characterisation of the product development process for simple and complex products (Adapted from Otto and Wood, 2001)	157
Figure 10.14: Application of DfEM to a Simple product with one design level	158
Figure 10.15: Independent use of DfEM across the supply chain	159
Figure 10.16: Application of DfEM tools to distributed design for complex products such as a car.....	160
Figure 11.1: Overview of case study 1 and case study 2	163

Figure 11.2: Breakdown of energy consumption for the manufacture of the elbow pipe (Pipe A).....	172
Figure 11.3: Plot of Process Efficiency Ratios, $ER_{process(n)}$, for each of the processes used to manufacture Pipe A – casting, grinding, ultrasonic inspection.....	172
Figure 11.4: Pie chart indicating the percentage breakdown of TE, AE and IE for Pipe A (left) and the efficiency ratios for the process, product and plant (right)	173
Figure 11.5: The ‘Create’ modules indicate the point where the products enter the system and the ‘Submodels’ represent the various production process. The products are then routed through the system according to the processes they require.....	178
Figure 11.6: Overview of the data assignments for Process 1 within Arena™	179
Figure 11.7: Overview of the data assignments for Process 2 within Arena™	180
Figure 11.8: Overview of the data assignments for Process 3 within Arena™	181
Figure 11.9: Overview of the data assignments for Process 4 within Arena™	182
Figure 11.10: The ‘Assign’ modules and the respective data inputs to calculate the EPEs (left) and the Efficiency ratios (right) for Product A	183
Figure 11.11: The detailed energy information is exported to Excel through the use of the ‘Read/Write’ module and is created within a submodel. The screenprint shows the submodel for exporting energy data for Product A. The inset shows the settings for the export of the TE (Process 1) for Product A.....	183
Figure 11.12: Graphical outputs of exported data within Excel. The final EPE and ER results for the three products are displayed within a single worksheet (left). The detailed energy breakdown for each process is displayed within individual worksheets (right).....	184
Figure 11.13: Overview of simulation model within Arena™ showing showing the process flow, the modules used for the calculation of the energy values, submodules that export the detailed energy and the embodied energy results Product A, B and C	184
Figure 11.14: Graphs showing the EPE for Process 1, 2 and 4 used in the manufacture of Product A	185
Figure 11.15: Graphs showing the EPE breakdown of Product A (left) and the various efficiency ratios for Product A (right)	185
Figure 11.16: Overview of results for Product A.....	186
Figure 11.17: Graphs showing the EPE for Process 2, 3 and 4 used in the manufacture of Product B.....	187

Figure 11.18: Graphs showing the EPE breakdown of Product B (left) and the various efficiency ratios for Product B (right)	187
Figure 11.19: Overview of results for Product B	188
Figure 11.20: Graphs showing the EPE for Process 1 and 4 used in the manufacture of Product C	189
Figure 11.21: Graphs showing the EPE breakdown of Product C (left) and the various efficiency ratios for Product C (right)	189
Figure 11.22: Overview of results for Product C	190
Figure 11.23: Overview of results for Products A, B and C	193
Figure 11.24: Decision support matrix for the DfEM process used for the casting process for Product C	195
Figure 13.1: Application of EPE framework to other levels through a hierarchical approach	212
Figure 13.2: Application of the DfEM approach to the Product, Process and Plant view point	214

List of Tables

Table 2.1: Types of products from an energy viewpoint, the research will focus on the production phase of these product families.	8
Table 3.1: Impacts and pollutants from various energy sources (adapted from David Coley, 2008)	22
Table 3.2: Part 1- Predicted consequences of climate change if no action is taken to reduce the use of fossil fuel use. Data from IPCC (2001), adapted from Coley (2008).....	25
Table 3.3: The relation between emissions and climate change according to IPCC (2007a).....	27
Table 3.4: Proportion of fuel used for electricity generation and respective carbon dioxide emissions. (Adapted from DECC, 2009 and POST, 2006)	29
Table 4.1: Overview of research work from a Product perspective	41
Table 4.2: Advantages and Disadvantages of the top-down and bottom-up method by Muller <i>et al.</i> (2007).....	48
Table 4.3: An overview of the research on a facility level.....	50
Table 4.4: Observations of energy consumption and processing parameters (Krishnan <i>et al.</i> , 2009).....	57
Table 4.5: Example of Machine Specifications of a TTC CNC machine including power rating of auxiliary equipment (Kalla, 2009)	58
Table 4.6: Energy consumption and spindle rpm profile for case study with results of the event reasoning (Vijayaraghavan and Dornfeld, 2010)	61
Table 4.7: Power-Saving Technologies in Grinding Machine (Park <i>et al.</i> , 2009)	62
Table 4.8: Average values of energy per unit material removal rate and recommended speeds and feeds (Kalla <i>et al.</i> , 2009)	65
Table 5.1: Evaluation of LCA based software that consists of energy modelling features	79
Table 5.2: Evaluation of various energy management software	82
Table 7.1: List of assumptions in the EPE Framework.	98
Table 8.1: List of sources for process and material energy information	105
Table 8.2: List of published research work on energy consumption of processes and equipment (*indicate studies that have been compiled by Gutowski <i>et al.</i> , 2009).....	106
Table 8.3: Establishing the Theoretical and Auxiliary Energy for some common processes.....	108

Table 9.1: Various domain requirements for the energy model for various users.	121
Table 9.2: Actual equation used to establish TE compared with the equivalent used in the simulation	126
Table 9.3: The expression used in the ‘Assign’ module to represent the sum of the various AE of the casting process.....	126
Table 9.4: The equation used in the framework and the equivalent expression used to represent the IE in the simulation model	128
Table 10.1: Key Factors to consider for Design for Energy Minimisation	153
Table 11.1: Processes required by case study 1 and the respective equations used to establish the TE for the processes.....	164
Table 11.2: List of data inputs for Case Study 1	165
Table 11.3: The values of the parameters for the elbow pipe for the casting process and the calculation of theoretical energy.....	166
Table 11.4: The calculation of the TE and AE for process 2, Grinding	167
Table 11.5: The calculation of the TE and AE for process 3 Inspection.....	168
Table 11.6: The calculation of IE for all 3 processes	169
Table 11.7: The calculation of the EPE for Pipe A.	170
Table 11.8: Calculation of efficiency ratios for the process, product and production system	171
Table 11.9: Summary of product details used in the case study.	174
Table 11.10: List of key assumptions associated with Case Study 2	175
Table 11.11: Equations used to calculate the TE of the processes used in Case Study 2	176
Table 11.12: List of data inputs for case study 2 (parenthesis indicate estimated values).....	177

Table of Contents

Acknowledgments	i
Synopsis.....	ii
Abbreviations	iii
List of Figures.....	v
List of Tables	xi
Table of Contents	xiii
Chapter 1 Introduction	1
Chapter 2 Aims and Scope of Research	6
2.1 Introduction	6
2.2 Research Context	6
2.3 Research Question.....	9
2.4 Aims and Objectives	10
2.5 Scope of Research	11
Chapter 3 Overview of Energy and its Impact on the Environment.....	14
3.1 Introduction	14
3.2 Energy and its Role in Modern Society	14
3.3 Sources of Power Generation	15
3.3.1 Non-Renewable Energy Sources	16
3.3.2 Renewable Energy Sources	19
3.3.3 Environmental Impact of Various Sources of Energy	21
3.4 Energy and Climate Change.....	23
3.4.1 Impact of Climate Change.....	23
3.5 Energy and Industry	29
3.5.1 Energy trends in the Manufacturing Sector	29
3.5.2 Role and importance of Energy Efficiency in Industry	33
3.6 Energy Legislation and Economic Measures	34
3.7 Chapter Summary.....	37
Chapter 4 Review of Energy Related Research in Industrial Systems	38
4.1 Introduction	38
4.2 Overview of Energy Related Research in Industrial Systems	38
4.3 Energy Research from a Product Designer's Perspective	40
4.4 Energy Research from a Manufacturer's Perspective	45
4.4.1 Energy Research on an Enterprise level	47
4.4.2 Energy Research on a Facility level	48
4.4.3 Energy Research within Production/Machine Cell.....	51
4.4.4 Energy Research associated with Production Machines and Equipment	52
4.4.5 Energy Research on the Tool-chip level (Theoretical Process Energy)	62
4.5 Management of Energy Data	67

4.6	Chapter Summary.....	73
Chapter 5	Review of Commercially Available Software for Energy Management and Analysis within Manufacturing Systems.....	75
5.1	Introduction.....	75
5.2	Overview of Commercial Software.....	75
5.3	Product life cycle based software.....	76
5.4	Energy Management Systems.....	80
5.5	Chapter Summary.....	83
Chapter 6	Research Methodology.....	84
6.1	Introduction.....	84
6.2	A Brief Overview of Research Methodology.....	84
6.3	Research Methodology Adopted in this Thesis.....	85
Chapter 7	Framework for Modelling Embodied Product Energy.....	89
7.1	Introduction.....	89
7.2	‘Plant’, ‘Process’ and ‘Product’ Perspective on Energy Consumption within a Manufacturing Facility.....	89
7.3	A Framework for Modelling Energy Flows within a Production System.....	92
7.4	Direct Energy.....	94
7.5	Indirect Energy.....	96
7.6	Embodied Product Energy.....	97
7.7	Key Assumptions made within the EPE framework.....	98
7.8	Chapter Summary.....	99
Chapter 8	Modelling Direct Energy and Indirect Energy.....	100
8.1	Introduction.....	100
8.2	Modelling Direct Energy and Indirect Energy.....	100
8.3	Data collection for EPE framework.....	101
8.3.1	Empirical Measurements.....	103
8.3.2	Use of Published Data in EPE Framework.....	105
8.3.3	Use of Mathematical Modelling to Generate Data for EPE framework.....	106
8.4	Calculation of Total DE within EPE Framework.....	109
8.5	Calculation of Total Indirect Energy within EPE Framework.....	110
8.6	Calculation of Embodied Product Energy (EPE).....	112
8.7	Defining Product, Process and Plant Efficiency Ratios.....	113
8.7.1	Process Efficiency Ratio.....	114
8.7.2	Product Efficiency ratio.....	115
8.7.3	Plant efficiency ratio.....	116
8.8	Chapter Summary.....	118
Chapter 9	Development of the Energy Simulation Model.....	119

9.1	Introduction	119
9.2	Energy Simulation Model	119
9.2.1	Users of the model.....	120
9.3	Software Implementation for Energy Simulation Model.....	122
9.4	Implementation of DE and IE within the ESM.....	123
9.4.1	Definition of Energy Data within the Model	123
9.4.2	Representation of DE and IE calculations within the model	125
9.5	Output from the Simulation Model	131
9.5.1	The Real Time Data related to Process Flow	131
9.5.2	The Embodied Product Energy Data	133
9.5.3	The Energy Graphs.....	134
9.6	Chapter Summary.....	137
Chapter 10 A Design for Energy Minimisation Methodology		138
10.1	Introduction	138
10.2	Overview of Design for Energy Minimisation.....	138
10.3	An Overview of the Existing Design Process	139
10.4	Evolution of Design for X.....	140
10.5	Life Cycle Approach to DfEM and Integration with the Design Process.....	141
10.6	Tools to support DfEM in Manufacturing	143
10.6.1	Streamlined Life Cycle Assessment	144
10.6.2	Energy Simulation Model.....	145
10.6.3	Advanced Energy Metering System	147
10.6.4	Integration of tools within the DfEM methodology	148
10.7	Using Energy Simulation Model (ESM) as part of DfEM.....	150
10.7.1	Energy Database.....	150
10.7.2	Simulation Engine	151
10.7.3	House of Quality based Design Support Tool	153
10.8	Application of DfEM in Centralised and Decentralised Design	156
10.9	Summary	161
Chapter 11 Case Studies		162
11.1	Introduction	162
11.2	Description of the Case Studies	162
11.3	Case Study 1: Application of EPE Framework in the Case of a Simple Product	164
11.3.1	Calculating DE for Product A	166
11.3.2	Calculating IE for Pipe A	168
11.3.3	Calculating EPE for Pipe A	169
11.3.4	Efficiency Ratios of Pipe A.....	170
11.3.5	Analysis of Results for Case Study 1	172
11.4	Case Study 2: Multiple Products.....	174
11.4.1	Data Inputs to the EPE Model.....	176
11.4.2	Use of the Simulation Model.....	178
11.4.3	Results of Case Study 2.....	185
11.4.4	Analysis of the Results for Case Study 2.....	191
11.4.5	Using the Results to support Design for Energy Minimisation	192
11.5	General Outcomes from the Case Studies.....	196

Chapter 12	Concluding Discussions	197
12.1	Introduction	197
12.2	Research Contributions and Achievements	197
12.3	Concluding Discussion.....	199
12.3.1	Review of the sources of power generation and various trends in energy consumption within the industrial sector.....	199
12.3.2	Review of energy management and modelling research, tools and software	200
12.3.3	Development of a framework to model embodied product energy	201
12.3.4	Development of an energy simulation model to support energy efficiency optimisation.....	202
12.3.5	Use of the energy simulation model to improve product design	203
12.3.6	Demonstration and validation of the applicability of the research concept.....	204
12.3.7	The vision for the future of Energy Efficient Manufacturing	205
12.4	Limitations of the Research	206
12.4.1	Range and detail of case studies.....	206
12.4.2	Consideration of integration of the software within other existing support systems	206
12.4.3	Implication of consideration of other sources of energy other than electricity.....	207
12.4.4	Energy cost and carbon footprint considerations.....	207
Chapter 13	Conclusions and Further Work	208
13.1	Introduction	208
13.2	Conclusions from the Research.....	208
13.3	Further Work.....	210
13.3.1	Establishment of a comprehensive central energy database	210
13.3.2	The Development of a more Sophisticated and Comprehensive Energy Simulation Model.....	211
13.3.3	Consideration of Economic Cost Benefits.....	213
13.3.4	Extending the Design for Energy Minimisation Approach to other Life Cycle Phases	213
References.....		215
Appendices.....		A1
Appendix 1	Other Methods of Attributing Indirect Energy	A2
Appendix 2	Details of the Modelling Modules used within Arena	A9
Appendix 3	Conference Paper Improving Product Design based on Energy Considerations	A16
Appendix 4	Journal Paper A Framework for Modelling Energy Consumption within Manufacturing Systems	A23
Appendix 5	Conference Paper A Framework for Modelling Energy Consumption within Manufacturing Systems	A33
Appendix 6	Journal Paper Minimising Embodied Product Energy to support energy efficient manufacturing	A42

Chapter 1 Introduction

Energy is an inextricable part of life in the 21st Century, thus its availability and utilisation will become increasingly important with the realisation of global climate change and the escalation in worldwide population. Energy demand is expected to continue to increase over the coming decades, with demand estimated to be more than 45% higher in 2030 when compared to today's levels (IEA, 2006). The use of energy is one of the main contributors to greenhouse gas emission which is resulting in changes to the climate (IPCC, 2007).

The phrase “low-carbon manufacturing” has been coined to reflect a comprehensive effort to reduce CO₂ emissions generated from energy consumed directly by manufacturing activities (e.g. specific process energy consumed per kilo of material processed, or per product manufactured), and the CO₂ produced through indirect energy consumption (e.g. general facility energy overheads such as heating and lighting). Future manufacturing businesses will have to adapt to the concept of ‘lean energy’ based on the most energy efficient processes within their production facilities. It is argued that despite the predicted growth in renewable energy technologies, in the short to medium term manufacturing activities will still rely heavily on electricity generated from fossil fuels. For example, the introduction of ‘renewable obligations’, requiring UK electricity suppliers to source a percentage of their capacity from renewable technologies, will necessitate 15% of the UK's energy demand to be generated from renewable sources by 2015 (HM Government, 2006). The remaining energy will clearly have to be produced through nuclear and fossil fuel power.

Achieving increased energy efficiency has become increasingly vital in light of the growing energy demand coupled with projections of shortages. Using energy more efficiently is often a cost effective way of cutting carbon dioxide emissions which also improves productivity and contributes to the security of our future energy supply. Energy efficiency can be defined as using less energy while maintaining the same level of service. It can be achieved either by decreasing total energy use or by increasing the

production rate per unit of energy consumed. In a manufacturing facility, energy efficiency can be achieved by using higher efficiency equipment, providing advanced systems to control energy use and improving operation and/or maintenance practices. In the UK, the Carbon Trust (2011) and the Climate Change Program Review by DEFRA (2008) have been set up to ensure that energy efficiency in businesses is encouraged. Performance indicators like the Carbon Trust Standard developed by the Carbon Trust (2008) recognises achievements in reduced carbon emissions and energy use by leading organisations in industry, commerce and the public sector.

There are several perspectives that can be used to assess the energy consumption within a manufacturing system (factory) as depicted in Figure 1.1. These include Plant, Process and Product viewpoints. In this context, the majority of current energy related research and tools focus on Plant (reduction of facility level energy demand) and Process (reduction of equipment level energy demand) perspective actions. The research assertion made in this thesis is that the Product perspective provides a distinctly different and useful method of identifying the energy hotspots within the manufacturing activities. This gives a greater degree of transparency not provided with Plant and Process viewpoints when analysing energy consumption within a system. Modelling tools developed based on this approach enable energy intensive processes used during the manufacture of a product to be identified.

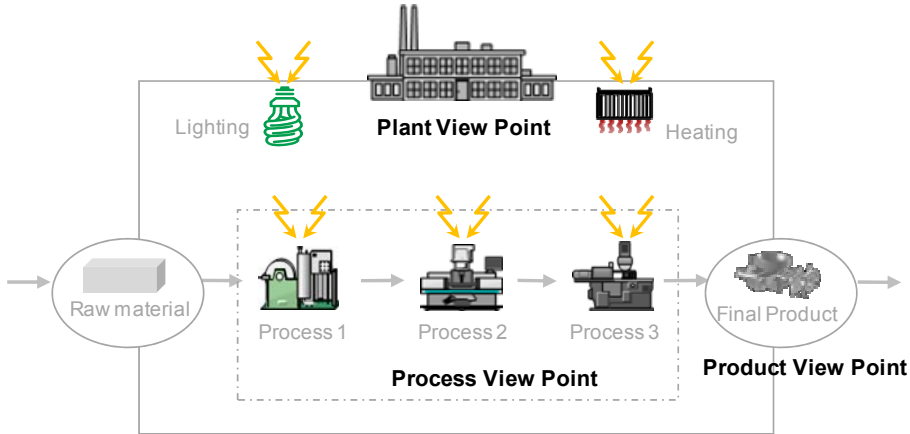

Figure 1.1: The three different perspectives used to assess energy consumption within a manufacturing system- Plant, Process and Product Viewpoint

Minimisation of energy consumption in manufacturing applications is a complex subject and covers a wide range of issues from raw material extraction and production processes to logistics and even end-of-life management. Therefore, many of the existing tools that focus on energy consumption are either very broad in scope (e.g. Life Cycle Assessment) where energy consumption is considered at a very high level over the product's life cycle, or are very simplistic in their attribution of energy use (e.g. Cumulative Energy Demand) where energy consumption is attributed to the average weight of material processed. This highlights the need for detailed modelling of energy consumption in a particular manufacturing system. As such the scope of the research reported in this thesis focuses on the production phase of a product's life cycle.

The research reported in this thesis investigates the use of energy during manufacture and its attribution to a single product, so as to provide designers and engineers with an indication of energy hotspots during the production phase. This is to enable the minimisation of energy consumption during this stage through design and operational improvements. This is achieved through:

- a) Developing a framework that can provide a breakdown of energy consumption during manufacture to identify the energy intensive processes thus highlighting the areas for improvement in production, production planning and product design
- b) Using simulation to handle the complexity involved in modelling and calculating the energy flows through a production system and to support 'what if' scenarios such as varying product types, changes in process parameters, scheduling plans and/or other production variations like set up times, queue times and batch sizes.

The structure of the thesis is broken down into three different sections: research background and overview, theoretical research, model development, and research conclusions as shown in Figure 1.2.

The research background and overview section encompasses Chapters 1 to 6 and provides an introduction to a range of issues regarding the use of energy and its impact on the environment as well as where energy is used in manufacturing and how it can be modelled. Chapter 2 provides a detailed insight into the context of the research and

outlines the research aims and objectives. Chapter 3 introduces the reader to the current energy situation in the world including the UK, the different sources of energy, its issues and impact on the environment, highlighting the need for energy rationalisation and demand control. Chapter 4 reviews the current research related to establishing energy flows within products and industrial systems highlighting the wide range of considerations and the challenges associated with modelling energy flows in both a product and within a production system. The final literature review chapter, Chapter 5 evaluates a range of commercially available software packages commonly used for analysing energy consumption over a product's life cycle and within a facility. Chapter 6 highlights the research methodology used in this thesis.

The theoretical research and development section encompasses five chapters and highlights the thesis's main contributions to research. Chapter 7 discusses the generation of a novel framework to establish the energy required to manufacture a product (Embodied Product Energy). Chapter 8 builds on the framework and elaborates on the calculations and methods used to obtain data. Chapter 9 describes the development of the energy model and simulation and Chapter 10 explores how the model can be used in the design process to minimise energy consumption in a product life cycle through the use of a Design for Energy Minimisation approach. Chapter 11 highlights suitable case studies to demonstrate the use of the energy simulation model and show how energy can be minimised.

The final section within this thesis includes two chapters (Chapters 12 and 13), which discuss the significance of the proposed energy framework in the context of the thesis scope, before drawing the final conclusions from this research and highlighting areas of further work.

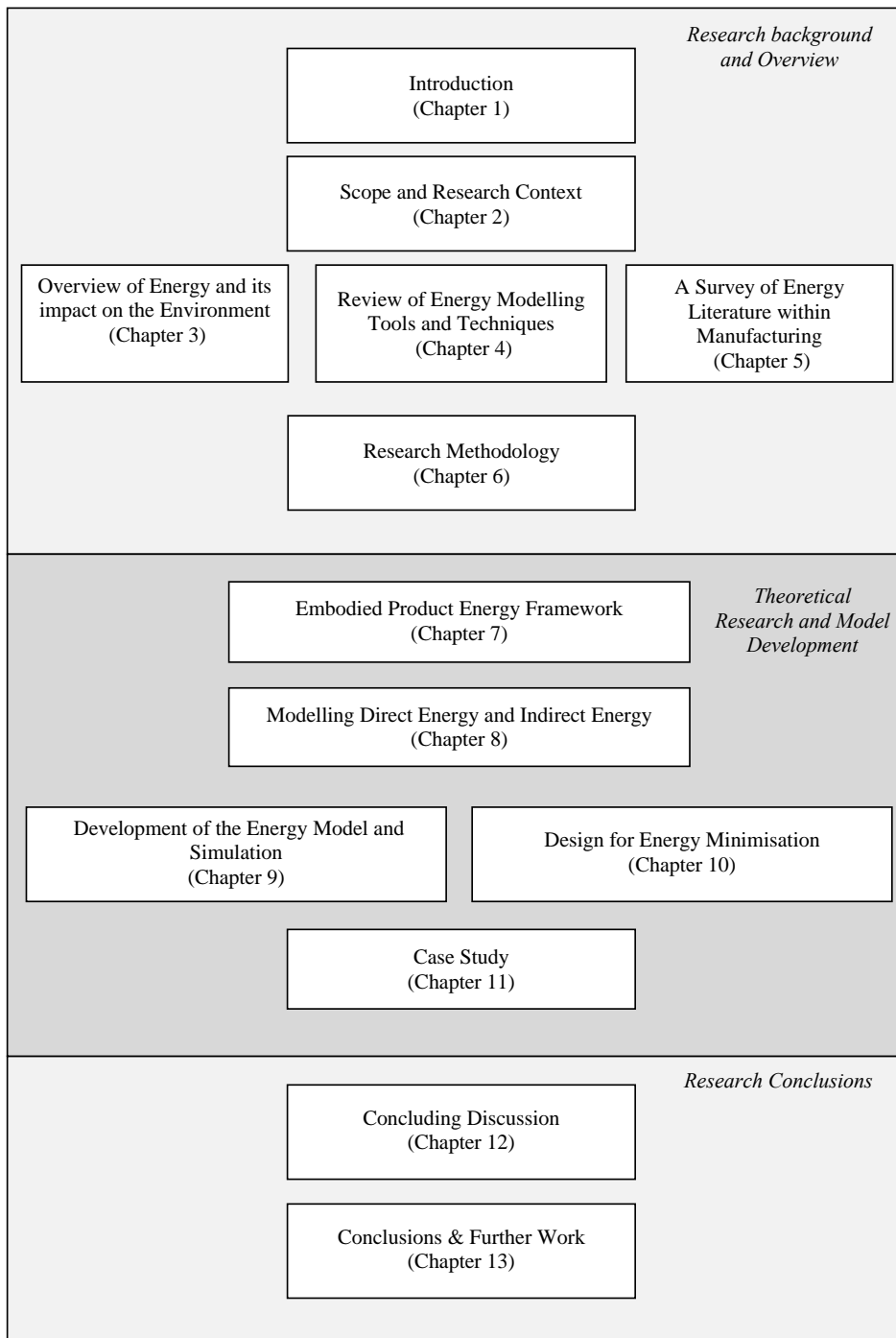

Figure 1.2: Overview of the thesis structure

Chapter 2 Aims and Scope of Research

2.1 Introduction

This chapter discusses the research context, overall aims, objectives and research scope. The preliminary part of the chapter describes the research context and in particular the primary question considered in this research. The later part of the chapter highlights the research objectives and their scope in the context of this thesis.

2.2 Research Context

Energy has become integral to our modern lifestyle, the demand for which is only expected to increase. The majority of our current energy is generated by fossil based fuels which account for two thirds of the world's greenhouse gas emissions. Despite recent advances in renewable energy technology, much of our energy will continue to be supplied by fossil based sources in the foreseeable future. Manufacturers, governmental agencies, local and national authorities, as well as the general public have come to realise that one of the ways of mitigating climate change requires targeted efforts on reducing energy consumption which has resulted in a proliferation of energy saving products, tools, standards and legislation.

Consumers can now choose more energy efficient products by referring to the energy ratings labelled on electrical goods. Local and national authorities have implemented various plans for more energy efficient homes and buildings. Governments have enforced energy acts to reduce carbon emissions from energy supplies. And manufacturers are increasingly incorporating micro cogeneration as well as energy monitoring systems to track their energy use within their facilities. This focus on energy reduction has also highlighted the importance of the rationalisation and optimisation of energy demand which is not only one of the most significant ways of reducing overall environmental impact, but also offers cost saving opportunities, especially in light of the rapidly rising cost of energy over the last few years.

As the research will be looking at various aspects of the manufacturing system in terms of different perspective, it is essential to clarify the terms ‘plant’, ‘process’ and ‘product’ which have been used to describe these perspectives.

‘Plant’ in this thesis refers to the factory building and the associated equipment required in maintaining optimal production environment (i.e. temperature, humidity, air purity, pressure etc).

Within a manufacturing enterprise, different types of processes can be found. In systems modelling, processes are often seen as a chain of activities that can be temporal or causal to achieve the purpose of the process. Processes are typically defined as “a conceptualisation of actions needed to achieve real-world transformations within finite time frames” (Weston *et al.*, 2007). There are many ways of classifying processes and further details can be found in Pandya *et al.* (1997), Andersen (2002) and Rose (2003). Common process classifications include: operational processes, infrastructural support processes, managerial processes and developmental/evolutionary processes (Pandya *et al.*, 1997). ‘Process’ this thesis refers to the operational processes which covers the actions taken by the machines or equipment that create value.

Comment [Y1]: Definition of process, plant and product

The definition of ‘product’ in this thesis is taken from the subject of product modelling as detailed by Krause *et al.* (1993). They define products as “materialised, artificially generated objects or groups of objects which form a functional unit”. The products can contain different parts (mechanical, electrical or hydraulic etc) and maybe made up different materials and manufactured by different processes from a range of lot sizes.

Much of the existing research on energy consumption within manufacturing has been from the Manufacturer’s perspective with the focus mainly on the Plant and Process level (for reviews of research work in these areas refer to Chapter 4), as outlined below:

- 1) *Plant facility level:* The focus of this work is mainly on the manufacturing facility such as the building infrastructure and the services associated with it such as lighting, heating and ventilation.
- 2) *Process equipment level:* This area of research is concerned with improving process (and equipment) efficiencies such as determining optimum turning

speeds on a lathe or processing temperatures in an oven for minimal energy consumption whilst achieving the desired finish.

The research assertion made in this thesis is that the independent use of these viewpoints does not provide a holistic overview of the energy hotspots within a manufacturing system. In addition, the author argues that within a complex application, the independent assessment of plant and process energy consumption does not allow for an effective prioritisation of the required investment in energy efficiency, thus this research attempts to analyse energy flows from a distinctly different viewpoint, i.e. a product viewpoint. This new approach highlights energy hotspots both in processes as well as the facility which can then be linked to casual factors such as production scheduling, process routing or in fact poor design of a particular product. Such holistic analysis of energy inefficiencies can then be used to improve production operations as well as product design.

Products are responsible for the consumption of energy over their life cycle from material extraction through to end-of-life. Some products consume energy during their 'Use' phase (e.g. electrical goods like televisions, kettles or fuel powered products like cars, airplanes and trains), whilst other products do not consume any energy during this phase, (e.g. pens, rulers or ornamental objects such as vases). Table 2.1 shows these two types of products and where energy is used over their life cycle.

Type of Products	Product Life cycle				Examples
	Material extraction	Production	Use	End-of-life	
Energy Consuming	✓	✓	Functional use ✓ <hr/> Non functional use ✓	✓	Electrical Appliances e.g. Television Kettles Computers Vehicles (car, motorcycles, vans etc.)
Non Energy Consuming	✓	✓	×	✓	Stationery e.g. Paper, pens Ornaments e.g. vases Toys

Table 2.1: Types of products from an energy viewpoint, the research will focus on the production phase of these product families.

For a complete assessment of the environmental impacts resulting from the energy consumption, the full life cycle of a product should be considered. However such full life cycle energy analysis often results in a lengthy data intensive exercise which at times, due to the lack of available data, requires significant assumptions and simplifications. Therefore the domain defined for the research reported in this thesis will only focus on the energy flow modelling within the ‘Production’ phase, as highlighted in Table 2.1. It is argued that the fundamental framework established by this research can be applied to the other phases in order to establish a model for the total energy consumed by the product (this is discussed in greater detail in Chapter 7).

2.3 Research Question

Traditionally in manufacturing applications, the optimisation processes to improve production efficiencies have primarily been based on a range of information related to product design attributes, for example:

- What material types and how much of each material is required,
- What are the range of production processes required to manufacture the product, and
- How much does it cost to manufacture a product, together with the breakdown of this cost.

To date various research has considered the minimisation of energy of various processes (e.g. milling, grinding, cutting etc.) and the reduction of energy required by services within a building (heating, lighting, ventilation etc.). This research is trying to address the efficiency of energy consumed by manufacturing processes and the related activities required to produce a product. The fundamental research question in this thesis is “How much energy is needed to manufacture a unit product?”

To be able to answer this fundamental research question, the following questions also need to be answered:

- Of the total energy consumed to manufacture a product, how much of the energy is used directly by the process and, how much is used by the facility that houses the process and the other supporting processes?

- When considering the energy consumed by the facility that houses the process how can it be attributed to the manufacture of a unit product?
- How much of the energy consumed by the process is for productive work and how much is non-productive?
- How can design influence the energy required to manufacture a product?

2.4 Aims and Objectives

The overall aim of this research is to model the total energy used to manufacture a single product and to utilise this model to improve both production and design decisions. The research will investigate the modelling of energy flows from a product rather than facility and/or process perspective, to provide a detailed breakdown of the energy consumed throughout the production phase of a product life cycle.

In order to achieve this aim the following research objectives have been defined:

1. To review literature on sources of power generation and major trends in energy consumption within various industrial sectors.
2. To review the state of art in energy management and modelling research and software tools.
3. To generate a framework to model the total energy used to manufacture a single product by considering both the energy consumed by the production processes and the environment required to maintain these processes.
4. To develop an energy simulation model for the optimisation of energy efficiency through the consideration of various ‘what-if’ scenarios.
5. To investigate the feasibility of using the energy simulation model to improve product design.
6. To demonstrate the applicability of research concepts and energy flow modelling framework through case study products.

2.5 Scope of Research

The scope of this research is in line with its objectives, as outlined in the remaining sections of this chapter.

- I. *Review literature on sources of power generation and trends in energy consumption within the industrial sector.*

In order to place the research in the appropriate context, a comprehensive review of the research that encompasses the various sources of energy generation (including both renewable and non-renewable forms), the impact of energy consumption on climate change, the implications of climate change, various energy trends and the significance of energy availability for long term sustainability of industrial activities will be undertaken. Peripheral to the review is an understanding of the relevant government policies, directives and associated legislative measures, and their impact on businesses and manufacturers. These will be discussed as part of the literature review in Chapter 3.

- II. *Review of the state of art in energy management and modelling research and software tools.*

To take advantage of the existing knowledge, a comprehensive review of literature surrounding energy management and modelling will be undertaken. The review will include both product focused research such as life cycle assessment, as well as the full spectrum of energy research within a manufacturing system from the enterprise level down to the turret level. In addition, an overview of the work and software developed by various commercial and governmental agencies will be conducted. The results from this review are included in Chapters 4 & 5.

- III. *Generate a framework to model embodied product energy*

The identification of various energy contributors during the production phase forms the basis of this framework. The scope of this research will be limited to the electricity consuming activities and processes but the framework could be extended to include other sources of energy as part of the further work. This framework aims to assist designers, engineers and manufacturers in identifying the direct and indirect energy consuming activities attributable to the manufacture of a product thereby providing

greater transparency of the energy used. This detailed breakdown provides a clear indication of energy hotspots which can then be used to optimise energy efficiency in both production and product design. In addition, the framework provides an opportunity to develop a number of efficiency ratios that can be used to compare energy efficiencies between processes, products and production systems supporting additional benchmarking opportunities. The framework will be introduced in Chapter 7 and further detailed in Chapter 8.

IV. Realisation of an energy simulation model to support energy efficiency optimisation.

Predicting the amount of embodied energy within a product during manufacture is a complex task which involves concurrent consideration of product, process and production data. Therefore this research will identify a suitable simulation technique to design and implement a prototype energy simulation model that incorporates various considerations included in the energy modelling framework. The model will also be used to demonstrate how energy efficiency optimisation can be achieved through the use of ‘what-if’ scenario planning. This will be described in Chapter 9.

V. To investigate the feasibility of using the energy simulation model to improve product design.

Much of a product’s production process and consequently its environmental impact are determined during the early stages of the design process. The research investigates a ‘Design for Energy Minimisation’ approach that incorporates the energy simulation model developed in this research with other supporting tools to aid designers and engineers reduce embodied product energy during the design process. Design can sometimes involve multiple stakeholders and the methodology would need to be further examined to determine its applicability to both simple products (where the design process can be managed and carried out by a single party) and complex products (where the design process can be managed by several parties). This ‘Design for Energy Minimisation’ approach will be described and discussed in Chapter 10.

VI. Demonstrate and Validate the Applicability of the Framework

In order to assess the validity of the research concepts and to highlight the applicability of the framework, the model will be evaluated through a number of case study products, using theoretical data, complemented by empirical data. The case study will investigate the use of the energy framework and simulation model to establish the energy hotspots and use the results to identify production and design improvements through changes in the processing parameters or changes in production configurations. Case study data will be used to populate the model and provide an initial assessment of the energy efficiencies of a manufacturing line with respect to a particular product design. The results of this analysis will then provide a foundation for possible design and operational improvements. This will be discussed in Chapter 11.

Chapter 3 Overview of Energy and its Impact on the Environment

3.1 Introduction

This chapter provides an overview of the role of energy in today's world and the various sources of energy including fossil based and renewable sources alongside a brief review on the advantages and disadvantages of each type of energy. The next part of the chapter investigates the impact of energy consumption on climate change and the implications of climate change to the environment and the manufacturing industry. The latter part of the chapter then presents energy trends and the role of energy within the industrial sector as well as the relevant energy directives and policies pertaining to industry.

3.2 Energy and its Role in Modern Society

Energy is very much woven into the fabric of modern society as summed up by this quote from the European Commission (2009): *“Energy is fundamental to the quality of our lives. Nowadays, we are totally dependent on an abundant and uninterrupted supply of energy for living and working. It is a key ingredient in all sectors of modern economies.”*

All through human history, the development of society has been inextricably linked to our ability to control and manipulate energy. The discovery of fire provided early man with the means of protecting themselves from predators and the harsh winters, greatly improving man's chances of survival. Since then, the evolution of modern energy and technology has enabled people to lead a lifestyle wholly dependent on energy. For the developing nations, energy not only provides a basic quality of life, it also supports and accelerates changes that improve and save lives. For these nations, energy means expanded industry, modern agriculture, increased trade and improved transportation, all of which are building blocks of economic growth that create the jobs that help people break out of the cycle of poverty and create better lives for future generations. In the

developed world, energy is not only a necessity, but also enriches and extends lives; powering computers, communication systems and even medical equipment.

As population increases in the developing countries, so too does the demand for energy. According to the International Energy Agency, IEA (2008), energy demand is expected to be 40% higher in 2030 compared to 2008 levels due to significant increases in demands from China and India, see Figure 3.1. The global demand for energy is being met by range of fuels sources, (the most common of which are coal, oil and gas) and is further described in the next section.

3.3 Sources of Power Generation

Sources of energy can be categorised into two categories: non-renewable and renewable. If the source is not replenishable in a short period of time, it is known as non-renewable and sources which are rapidly replenished, like wind and solar are known as renewable. Global energy demand is expected to grow by 40% between 2007 and 2030 and much that demand will be supplied by sources which are non-renewable. According to the IEA (2009), approximately 85% of all energy currently produced and consumed is derived from the finite supplies of fossil fuels as the primary energy source, with the remaining coming from nuclear and renewable sources as shown in Figure 3.2. The graph shows a slight reduction in energy demand in 2008-2009 due to the economic crisis which saw a reduction of trade and therefore energy demand. The dotted black line shows the projected world demand up to 2030 before the financial crisis.

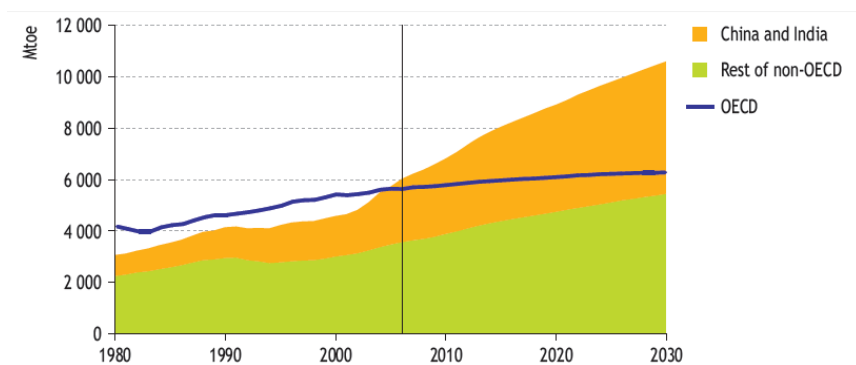

Figure 3.1: World energy demand by region. (IEA, 2008a)

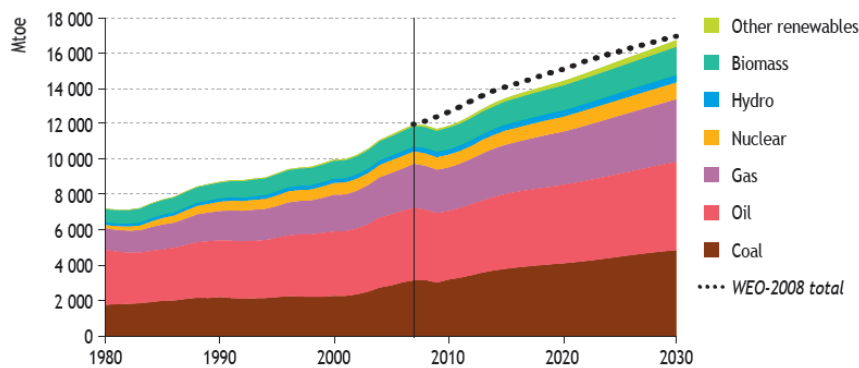

Figure 3.2: World primary energy demand by fuel (IEA, 2009)

As clearly indicated in Figure 3.2, fossil fuels – oil, natural gas and coal – will continue to meet most of the world’s needs during this period because no other energy sources can match their availability, versatility, affordability and scale. By 2030, global demand for natural gas will be more than 55 percent higher than it was in 2005 (IEA, 2009). Nuclear power will also grow significantly to support increasing needs for power generation. Although wind, solar and biofuels will grow sharply leading up to 2030, at nearly 10 percent per year on average, their contribution by 2030 will remain relatively small at about 2.5 percent of total energy because they are starting from a small base.

3.3.1 Non-Renewable Energy Sources

The most common forms of non-renewable or fossil based energy sources are oil, natural gas and coal. Uranium whilst not a fossil fuel is also non renewable. Currently, all these sources of energy supply a large proportion of our energy needs.

3.3.1.1 Oil

Oil is formed from the plant and animal remains that lived in a marine environment which later was covered by sand and silt and was heated and pressurised by these layers to form crude oil.

The advantage of using oil to generate energy is that it is easily combustible, produces high specific energy density (approximately 45 MJ/kg, as shown later in Table 3.2) and is also easy to extract and transport. In addition oil is also very versatile, various compounds and mixtures can be extracted from crude oil such as gasoline and diesel for automobiles, kerosene, some types of alcohol and lubricating oils, most of which have

widespread use in daily life. In addition a whole range of products can be derived from oil e.g. plastics, asphalt, paraffin wax etc. A key advantage is that oil prices remains low compared to other forms of energy with lower environmental impacts like wind or solar, and unlike hydrogen or gas, it is easy to transport and has a wider range of developed infrastructure available to support its use.

The disadvantages of oil are that it is a finite resource and is depleting at rapid rate, its combustion releases CO₂ originally stored in the earth for millions of years and harmful by-products are also generated in the process. The extraction of oil leads to degradation of the surrounding environment and occasional oil spillages often result in high environmental cost to the surrounding wildlife and eco systems.

3.3.1.2 Natural Gas

Natural gas, like oil and coal was formed from the remains of plants and animals millions of years ago under compression and pressurisation from the earth. Natural gas can also be produced by microorganisms (or methanogenic organisms) often found in marshes, bogs and landfills that break down organic matter into methane. Methane is the main constituent in natural gas and is often found with other fossil fuels.

Unlike other fossil fuels, natural gas is relatively clean burning and emits lower levels of harmful by-products into the atmosphere. It also has a higher energy density than coal. Natural gas is relatively inexpensive compared to coal and as it is transportable over a pipeline, it is less susceptible to bad weather conditions unlike coal or oil which are typically transported by road or rail.

The disadvantage of natural gas is that it is highly flammable and needs to be produced in closely controlled conditions. Natural gas unless treated is colourless and odourless and tasteless which makes detection of hazardous leaks difficult.

3.3.1.3 Coal

The energy in coal comes from the energy stored long ago by trees and ferns which was initially decomposed by aerobic bacteria and then covered anaerobically, producing peat which when heated and pressurised further became coal. The carbon from coal is also used in the process of making steel and is commonly used in the concrete and paper industries.

Coal is one of the most abundant sources of energy, more so than oil and gas and unlike oil, coal is widely available, is inexpensive and is not limited to certain geographical regions, making it less susceptible to geopolitical tensions. Coal can be safely stored and can be used to create energy in times of emergency, additionally coal based power is not weather dependant which cannot be said for most forms of renewable like wind and solar.

Mining of coal can damage the surrounding ecosystems, affect water quality and also cause health issues for miners. The combustion of coal produces harmful substances like sulphur dioxides, nitrogen oxides, arsenic and ash which can cause significant environmental problems such as acid rain. It also emits twice as much carbon dioxide compared to natural gas per unit of heat, increasing greenhouse gas emissions (Hansen, 2006). Additional emissions are also contributed by the transportation of coal (e.g. emissions from the lorries used to transport the coal from the mines to the power stations).

3.3.1.4 Uranium (Nuclear Fission)

Uranium, a commonly found metal, is used in nuclear plants for nuclear fission. In nuclear fission, the atoms are split apart to form smaller atoms, releasing energy in the form of heat, which is used to drive turbines, producing electricity. U-235 is the specific type of uranium that is used due to the ease of atoms splitting.

Nuclear power costs about the same as coal and does not contribute to the greenhouse effect. A huge amount of energy can be produced from small amounts of fuel and it only produces a small amount of waste. Nuclear power is a reliable source of energy and non weather dependant.

The main environmental concerns for the use of nuclear power are radioactive wastes such as uranium mill tailings, spent reactor fuel and other radioactive wastes (Glasstone and Jordan, 1980). Besides being radioactive, Uranium is highly toxic and therefore harmful to humans. Uncontrolled nuclear reactions can have disastrous and widespread impact on the environment as such nuclear power plants need to have complex safety and security features.

3.3.2 *Renewable Energy Sources*

Renewable energy sources are derived naturally and are constantly replenished and will not run out. Some of these natural sources of energy are sunlight, wind, rain, hydropower and geothermal heat.

3.3.2.1 Solar

Solar energy is the sun's rays (solar radiation) that reach the Earth. This energy can be converted into other forms of energy, such as heat and electricity. Solar powered electrical generation relies on photovoltaic cells or heat engines.

The main advantage is that solar energy is renewable and solar cells provide a non-polluting and cost effective solution to energy problems in places where there is no mains electricity. In addition photovoltaic cells are easy to install and as they have no moving parts, they are easy to maintain and can last a long time.

The main disadvantage is the initial cost of solar cells. At present solar energy is more than twice the price of fossil derived energy (Lewis, 2007). Other issues with solar energy is that it is intermittent (i.e. cloudy days may affect performance and no energy can be generated at night).

3.3.2.2 Geothermal

Power is extracted from the heat trapped in the earth's core and the decay of radioactive isotopes in the crust, mantle and core. The heat from the Earth's core heats up the underground water in turn producing steam which is channelled through deep holes that have been drilled to drive turbines to generate electricity.

The advantages of geothermal are that it does not produce any pollution and does not contribute to the greenhouse effect. The power stations are also relatively small so has little impact on the environment. The running costs of a geothermal power plant are relatively low as no fuel is required to generate the electricity.

The main issue with geothermal energy is that it is limited to certain geographical locations. Most of the locations may be situated in harsh environmental conditions at high altitudes or near active volcanoes. In addition, geothermal sites may experience reduced outputs due to depletion of the water source.

3.3.2.3 Hydropower

In hydropower, energy is generated from the movement of water such as rivers and streams. Typically dams are built on rivers to store the water in a reservoir which is then released in a controlled manner which flows through turbines thus generating electricity.

The main advantages of hydropower are that it is non-polluting, technologically mature, and uses a renewable energy source that does not contribute to global warming.

As large areas are often flooded to create the reservoir once the dam is built the natural environment is often destroyed resulting in the loss of habitat for both animals and humans. In addition to the significant costs of building a dam, the cost of a dam failure is just as high, as a breached dam can often result in the loss of lives.

3.3.2.4 Wind Energy

The uneven heating of the Earth's surface causes some air to rise in the areas that are warmer. Wind is generated as the surrounding air moves in to replace the rising warm air. Wind energy is harnessed through the use of wind turbines that convert the moving air into wind power.

Wind power is plentiful, available in many regions around the world, free and can be captured effectively with modern technology. Most importantly, it does not produce any greenhouse gas emissions during operation. Wind turbines do not occupy a large land area and the land beneath the turbine can be used for other purposes, also the turbines can be made in a range of sizes, so can be suited for various uses, from supporting an entire city to a single household.

Like solar energy, wind power can be intermittent and there will be times when no power is generated at all. Wind turbines are large structures and are noisy during operation which can make the country side less pleasant for some people. The manufacture of wind turbines produce pollution and hence it is not entirely environmentally friendly, moreover a large number of turbines are required to sustain large demands as the largest single turbine can only provide approximately 3500kW which is enough to power only 1500 households (Joselin Herbert, 2007).

3.3.2.5 Bioenergy

Bioenergy is extracted from materials that are from biological sources such as wood, sugar cane and other solid waste like manure which has stored energy from sunlight. Some sources of biomass are combusted directly to generate energy from heat; others like sugar cane are allowed to ferment to make biofuel which can be burned to generate power.

The main advantage of burning biomass is that it is more reliable than solar or wind energy. The use of bioenergy saves the environmental cost of disposing waste material. Growing of plants for biofuel could provide a carbon sink to remove carbon dioxide from the atmosphere. Biomass is a resource that is available throughout the world unlike other sources of energy such as geothermal and oil.

However the growth of crops for biofuels may compete with land usage for crops grown for consumption especially if they are to replace fossil fuels (Gurgel *et al.*, 2007). The combustion of biomass still contributes to global warming and pollution when burned (Kim *et al.*, 2009). It is also expensive to collect, harvest and store the raw materials.

3.3.3 Environmental Impact of Various Sources of Energy

As highlighted within each energy source, there are benefits and disadvantages with using energy regardless of how it is derived. A summary of the specific energy density of the various sources as well as the main problems associated with the various sources of fuel are given in Table 3.1. In terms of non renewable energy sources, the complexity and the safety concerns with using nuclear energy limits its use, despite being extremely energy dense. On the other hand oil and gas are the next highest in energy density, are ideal fuels for energy use in everyday life as the energy is easily accessible through combustion, however the use of fossil fuels is typically attributed to increased carbon emissions and are the main contributors to climate change. On the whole, renewable sources of energy do not contribute as much to climate change as fossil derived fuels although the systems that need to be built to harness renewable energy often result in changes to the landscapes and may impact surrounding habitats. These ramifications are commonly associated with hydro-electricity and wind energy. Whilst the various associated environmental impacts are valid issues for consideration, there are perhaps none as pressing and as significant as climate change.

	Source	Specific Energy Density (MJ/kg)	Potential Cause for Concern
Non Renewable	Oil	45	Global climate change, air pollution by vehicles, acid rain, oil spills, oil rig accidents
	Natural Gas	38-50	Global climate change, methane leakage from pipes, methane gas explosions, gas rig accidents
	Coal	29-33	Global climate change, acid rain, environmental spoliation by open-cast mining, land subsidence due to deep mining, spoil heaps, ground water pollution, mining accidents, health effects on miners
	Nuclear Power	77,000,000	Radioactivity (routine release, risk of accident, waste disposal), misuse of fissile and other radioactive material by terrorists, proliferation of nuclear weapons, land pollution by mine tailings, health effects on uranium miners
Renewable	Biomass	9-21	Effect on landscape and biodiversity, ground water pollution due to fertilizers, use of scarce water, competition with food production.
	Hydro-electricity	-	Displacement of populations, effect on rivers and ground water, dams (visual intrusion and risk of accident, seismic effects, downstream effects on agriculture, methane emissions from submerged biomass
	Wind power	-	Visual intrusion in sensitive landscapes, noise, bird strikes, interference with telecommunications
	Tidal power	-	Visual intrusion and destruction of wildlife habitat, reduced dispersal of effluents (these concerns apply mainly to tidal barrages, not tidal current turbines)
	Geothermal	-	Release of polluting gases, (SO ₂ , H ₂ S, etc) ground water pollution by chemicals including heavy metals, seismic effects
	Solar energy	-	Sequestration of large land areas (in the case of centralised plant), use of toxic materials in manufacture of some PV cells, visual intrusion in rural and urban environments.

Table 3.1: Impacts and pollutants from various energy sources (adapted from David Coley, 2008)

3.4 Energy and Climate Change

3.4.1 *Impact of Climate Change*

Climate change has been the subject of interest both within the scientific community and the public, and now increasingly among politicians. Changes in the climate will affect everyone and will have significant implications for present lives, future generations and for ecosystems on which humanity depends (The Royal Society, 2010).

The global average air and ocean temperatures have increased over the past 100 years and with the last decade being the warmest since records began: 0.6°C higher since 1990 (IPCC, 2007a). According to IPCC, there is empirical evidence of increases in air and ocean temperatures, widespread melting of snow and ice and rising sea levels, see Figure 3.3. According to their models, global surface temperatures are likely to continue rising which would cause glaciers to retreat, sea ice to melt and sea levels to rise in turn changing the amount of precipitation leading to extreme weather which would lead to changes in the physical and biological systems.

There are more possible effects of climate change than there is space here for and the author would recommend the IPCC Fourth Assessment Report on the Impacts, Adaptation and Vulnerability (IPCC, 2007b) for a detailed assessment of the future impacts on various systems, sectors and regions. For a quick overview of the impacts, Coley (2008) has qualitatively summarized the likely consequences if no concerted effort was made to mitigate climate change. They are based on three scenarios at three different dates and different temperature rise (see Table 3.2). The impacts are categorised into the following: Human health effects, Ecosystem effects, Agriculture effects, Water Resource effects and other Market sector effects. There is a very high probability that heat stress and winter mortality will increase and extreme changes to crop yields and water supply would become increasingly common.

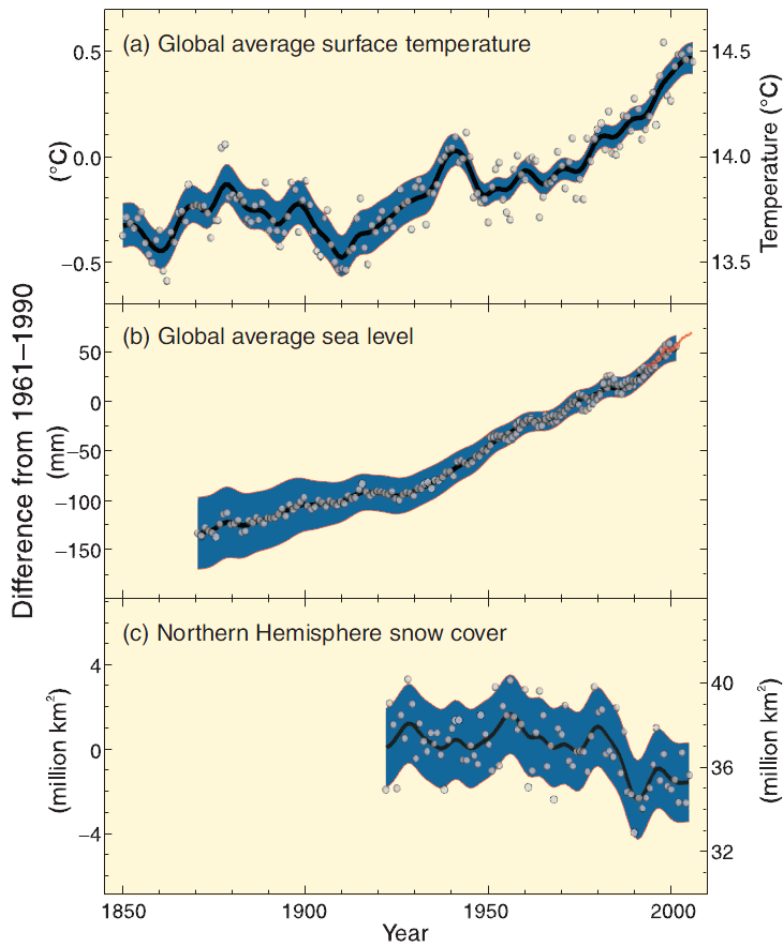

Figure 3.3: Observed changes in (a) global average surface temperature; (b) global average sea level from tide gauge (blue) and satellite (red) data; and (c) Northern Hemisphere snow cover for March-April (IPCC, 2007a)

Parameter	2025	2050	2100
CO ₂ concentration	405-460 ppm	445-640 ppm	540-970 ppm
Global mean temperature change from the year 1990	0.4-1.1 °C	0.8-1.1 °C	1.4-5.8 °C
Global mean sea-level rise from the year 1990	3-14 cm	5-32 cm	9-88 cm
<i>Human health effects</i>			
Heat stress and winter mortality	Increase in heat related deaths and illness (high confidence). Decrease in winter deaths and some temperate regions (high confidence)	Thermal stress effects amplified (high confidence)	Thermal stress effects amplified (high confidence)
Vector-and water-borne diseases		Expansion of areas of potential transmission of malaria and dengue (medium to high confidence)	Further expansion of area of potential transmission (medium to high confidence)
Floods and storms	Increases in deaths, injuries and infections associated with extreme weather (medium confidence)	Greater increases in deaths, injuries and infections associated with extreme weather (medium confidence)	Greater increases in deaths, injuries and infections (medium confidence)
Nutrition	Poor are vulnerable to increased risk of hunger, but state of science very incomplete	Poor remain vulnerable to increased risk of hunger	Poor remain vulnerable to increased risk of hunger
<i>Ecosystem effects</i>			
Corals	Increase in frequency of coral bleaching and death (high confidence)	More extensive coral bleaching and death (high confidence)	More extensive coral bleaching and death (high confidence)
Coastal wetlands and shorelines	Loss of some coastal wetlands to sea level rise (medium confidence). Increased erosion of shorelines (medium confidence).	Further loss of some coastal wetlands (medium confidence). Further erosion of shorelines (medium confidence).	Further loss of some coastal wetlands (medium confidence). Further erosion of shorelines (medium confidence).
Terrestrial ecosystems	Lengthening of growing season in mid-and high latitudes; shifts in ranges of plant and animal species (high confidence). Increase in net primary productivity of many mid and high latitude forests (medium confidence). Increase in frequency of ecosystem disturbance by fire and insect pests (high confidence)	Extinction of some endangered species; many others pushed closer to extinction (high confidence). Increase in net primary productivity may or may not continue. Increase in frequency of ecosystem disturbance by fire and insect pests (high confidence)	Loss of unique habitats and their endemic species (medium confidence). Increase in frequency of ecosystem disturbance by fire and insect pests (high confidence)
Ice environments	Retreat of glaciers, decrease sea-ice extent, thawing of some permafrost, longer ice free seasons on rivers and lakes (high confidence).	Extensive Arctic sea-ice reduction benefitting shipping but harming wildlife (medium confidence). Ground subsidence leading to infrastructure damage (high confidence)	Substantial loss of ice volume from glaciers, particularly tropical glaciers (high confidence)

Table 3.2: Part 1- Predicted consequences of climate change if no action is taken to reduce the use of fossil fuel use. Data from IPCC (2001), adapted from Coley (2008)

Parameter	2025	2050	2100
<i>Agricultural effects</i>			
Average crop yields	Cereal crop yields increase in many mid and high latitude regions (low to medium confidence). Cereal crop yields decrease in subtropical regions (low to medium confidence)	Mixed effects on cereal yields in mid-latitude regions. More pronounced cereal yield decreases in tropical and subtropical regions (low to medium confidence)	General reduction in cereal yields in most mid-latitude regions for a warming more than a few °C (low to medium confidence)
Extreme low and high temperatures	Reduced frost damage to some crops (high confidence). Increased heat stress damage to some crops (high confidence). Increased heat stress in livestock (high confidence)	Effects of changes in extreme temperatures amplified (high confidence)	Effects of changes in extreme temperature amplified (high confidence)
Incomes and prices		Incomes of poor farmers in developing countries decreased (low to medium confidence)	Food prices increased relative to projections that exclude climate (low to medium confidence)
<i>Water resource effects</i>			
Water supply	Peak river flow shifts from spring toward winter in basins where snowfall is an important source of water (high confidence)	Effect of changes in extreme temperatures amplified (high confidence)	Water supply effect amplified (high confidence)
Water quality	Water quality degraded by higher temperatures. Water quality changes modified by changes in water flow volume. Increase in saltwater intrusion into coastal aquifers due to sea level rise. (medium confidence)	Incomes of poor farmers in developing countries decreased (low to medium confidence)	Water quality effect amplified (high confidence)
Water demand	Water demand for irrigation will respond to changes in climate; higher temperatures will tend to increase demand (high confidence)	Water supply decreased in many water-stressed countries, increased in some other water stressed countries (high confidence)	Water demand effect amplified (high confidence)
Extreme events	Increased flood damage due to more intense precipitation events (high confidence). Increased in drought frequency (high confidence)	Further increase in flood damage (high confidence). Further increases in drought events and their impacts.	Flood damage several-fold higher than 'no climate change' scenarios'
<i>Other market sector effects</i>			
Energy	Decreased energy demand for heating buildings (high confidence). Increased in energy demand for cooling buildings (high confidence)	Energy demand effect amplified (high confidence)	Energy demand effect amplified (high confidence)
Financial sector		Increased insurance prices and reduced insurance availability (high confidence)	Effects on financial sector amplified
Aggregate market effects	Net market sector losses in many developing countries (low confidence). Mixture of market gains and losses in developed countries (low confidence)	Losses in developing countries amplified (medium confidence). Gains diminished and losses amplified in developed countries (medium confidence)	Losses in developing countries amplified (medium confidence). Net market sector losses in developed countries from warming of more than a few °C (med confidence).

Table 3.2. Part 2- Predicted consequences of climate change if no action is taken to reduce the use of fossil fuel use. Data from IPCC (2001), adapted from Coley (2008)

According to the IPCC there is strong evidence that the observed rise in temperature is very likely due to the increase in greenhouse gas emissions (a 70% increase between 1070 and 2004) as a result of the increase in human activities since pre-industrial times. The atmospheric concentrations of CO₂ and CH₄ in 2005 exceed by far the natural range over the last 650,000 years. Global increases in CO₂ concentrations are due primarily to fossil fuel use, with land-use change providing another significant but smaller contribution. It is very likely that the observed increase in CH₄ concentration is predominantly due to agriculture and fossil fuel use.

In order to limit global temperature rise to 2°C, the IPCC suggests that carbon emissions need to be reduced by 50-80% of the levels in 2000, a summary of various temperature increases and the respective CO₂ reduction are shown in Table 3.3. The Stern review (Stern, 2007) concluded that the benefits of limiting temperature rises to within 2°C would considerably outweigh the costs of doing so and proposes that one percent of global gross domestic product (GDP) per annum be invested to mitigate the worst effects of climate change.

According to IPCC (2007a), about 69% of all CO₂ emissions are energy related and about 60% of all green house emissions can be attributed to energy supply and energy use. Unless current policies change, it is predicted that global energy-related CO₂ emissions will grow 57% by 2030 from 2005 levels. The demand for energy will continue to increase, and the IEA (2007a) predicts that it will be 40% higher in 2030 with fossil fuels remaining dominant, meeting 84% of this increment. CO₂ capture and storage can prevent CO₂ from being released into the atmosphere, with the potential to reduce CO₂ emissions from fossil fuel plants by between 85% and 95% (IEA, 2006).

Temperature increase (°C)	All GHGs (ppm CO ₂ eq.)	CO ₂ (ppm CO ₂)	CO ₂ emissions 2050 (% of 2000 emissions)
2.0-2.4	445-490	350-400	-85 to -50
2.4-2.8	490-535	400-440	-60 to -30
2.8-3.2	535-590	440-485	-30 to +5
3.2-4.0	590-710	485-570	+10 to +60

Table 3.3: The relation between emissions and climate change according to IPCC (2007a)

The results show a "best estimate" of 4°C being reached by 2070, with a possibility that it will come as early as 2060, if greenhouse gas emissions are not cut soon then we could see major climate changes within our own lifetimes (Betts, 2009).

Electricity consumption is growing rapidly in many countries and its global consumption has increased by more than 200% since 1971, see Figure 3.4. Two thirds of the world's electricity is generated from fossil fuels with coal and gas continuing to play an important role even in a CO₂ constrained world, see Figure 3.5.

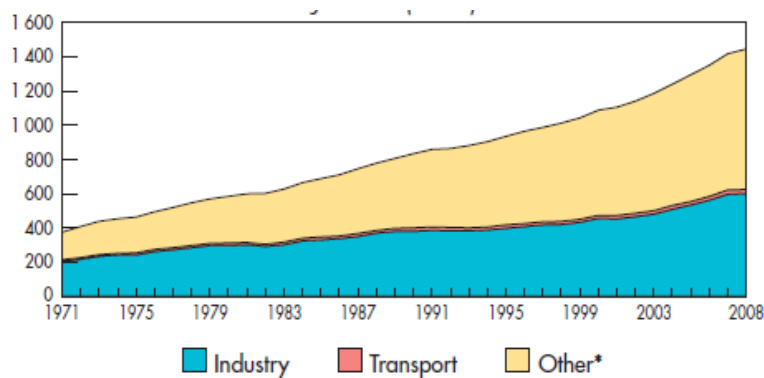

Figure 3.4: Electricity consumption (Mtoe) by sector between 1971 to 2008 (IEA, 2010a)

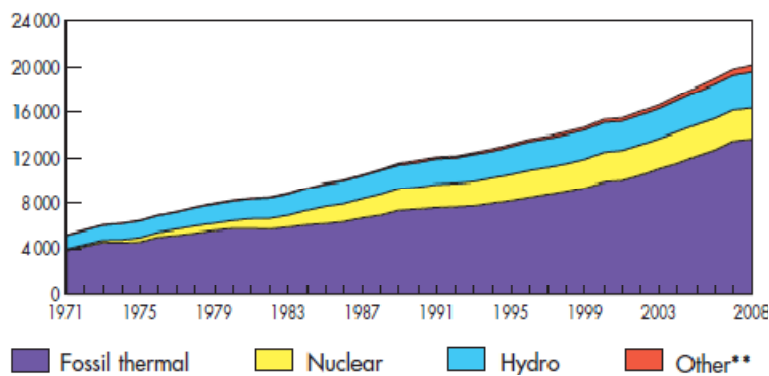

Figure 3.5: Electricity generation (TWh) by fuel type from 1971 to 2008 (IEA, 2010a)

Approximately 40% of the world's electricity comes from coal, in some countries this percentage can be much higher (90% in South Africa and Poland, 80% in China and Australia, more than 66% in India). Currently around 20% of the world's electricity comes from gas. Russia produces almost half its electricity from gas and within the UK at 40% and the US and Japan at around 20% (IEA, 2008b). Currently more than 70% of the electricity generated in the UK are from fossil fuels which in addition to being non renewable, emit large amounts of CO₂, see Table 3.4.

There is no doubt that the combustion of fossil fuels generates CO₂ and it is also clear that the demand for fossil fuels will continue to rise to meet the world's energy needs. There is compelling evidence that CO₂ emissions are the main contributor to climate change and unless we drastically limit the amount of CO₂ release into the atmosphere, climate change will be imminent and its effects will have global implications.

3.5 Energy and Industry

3.5.1 Energy trends in the Manufacturing Sector

There are four primary sectors that consume energy: manufacturing, households, transport and services. The manufacturing sector covers the manufacture of finished goods and products, mining and quarrying of raw materials and construction. Directly or indirectly, manufacturing industry accounts for more than one-third of the global energy use and CO₂ emissions (IEA, 2008b), this figure is higher in developed countries where most of the energy is allocated to manufacturing and transportation sectors (Moan and Smith, 2007).

Fuel Used for Electricity Generation	% electricity generation in the UK, 2008	Carbon emitted (g/kWh)
Gas	46.1	357
Coal	31.2	880
Nuclear	12.5	5
Renewables and other	6.3	<100
Oil	1	650

Table 3.4: Proportion of fuel used for electricity generation and respective carbon dioxide emissions. (Adapted from DECC, 2009 and POST, 2006)

Although the industrial sector is currently the second highest energy consumer after buildings, the projections for worldwide industrial energy consumption is expected to grow from 3000 Mtoe in 2010 to 5000 Mtoe becoming the top energy consumer in 2050, see Figure 3.6 (IEA, 2008). The manufacturing sector was also the highest contributor to carbon emissions with a share of 38% in 2005, see Figure 3.7.

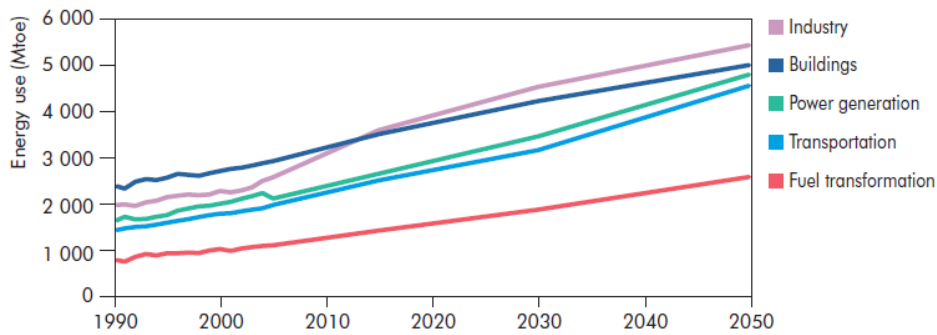

Note: Final energy use for end-use sectors, net consumption of power and fuel for the transformation sectors. The power-generation sector includes heat plants.

Figure 3.6: Energy use by sector from 1990 to 2050. (IEA, 2008)

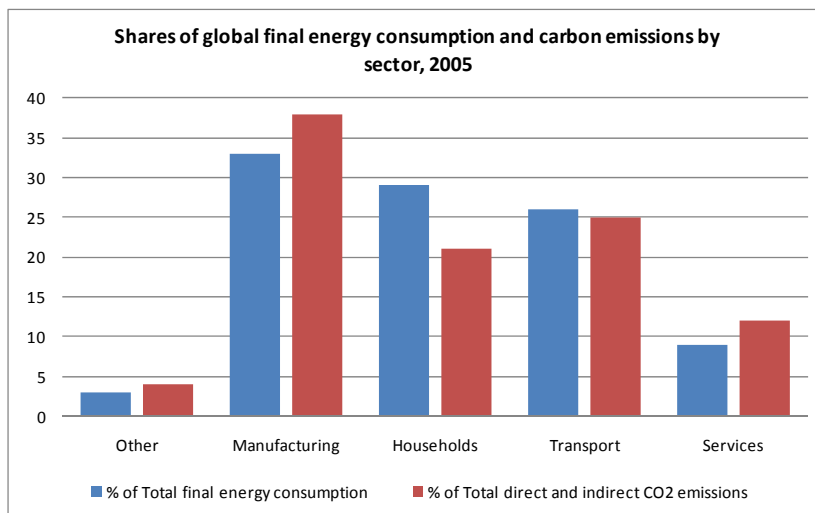

Figure 3.7: Shares of global final energy consumption and carbon emissions by sector, 2005 (adapted from IEA, 2008a)

As one of the largest consumers of energy, the US accounts for 25% of the worldwide energy use of which 33% is used by the industrial sector. Within this sector manufacturing consumes 73% of the energy use (Evans, 2003). Similarly, in UK, the industry also accounted for a significant proportion of energy use, 25% of the final energy consumed is attributable to the Industrial sector, (see Figure 3.8). In terms electricity consumption, industry also consumed a large proportion at 34%, see Figure 3.9.

According to the latest updated data from BERR (2009), more than 50% of the energy consumed by the UK industrial sector was for processes, with low temperature processes being the most significant at 36% of the total energy consumption by industry (Figure 3.10). The energy intensity of most industrial processes is at least 50% higher than the theoretical minimum determined by the laws of thermodynamics. In energy intensive industries such as paper, chemicals, steel and cement manufacturing, cost-effect efficiency gains are possible in the order of 10%-20% using commercially available technology. In processes where efficiency is close to the practical maximum, innovations in materials and processes could enable even further gains.

This indicates that of all areas, manufacturing is the most energy intensive with large amounts of energy used in inefficient processes, thus indicating there is room for energy improvements in this area.

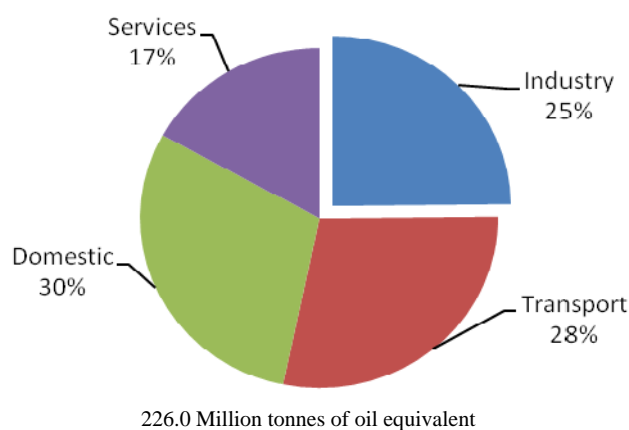

Figure 3.8: Final energy consumption of various sectors (UK) in primary energy equivalent in 2007
(Source: BERR , 2009)

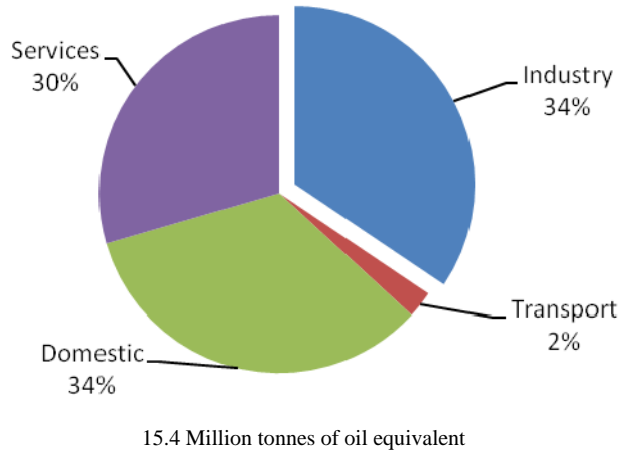

Figure 3.9: Electricity consumption of various sectors (UK) in primary energy equivalent in 2007
(Source: BERR, 2009)

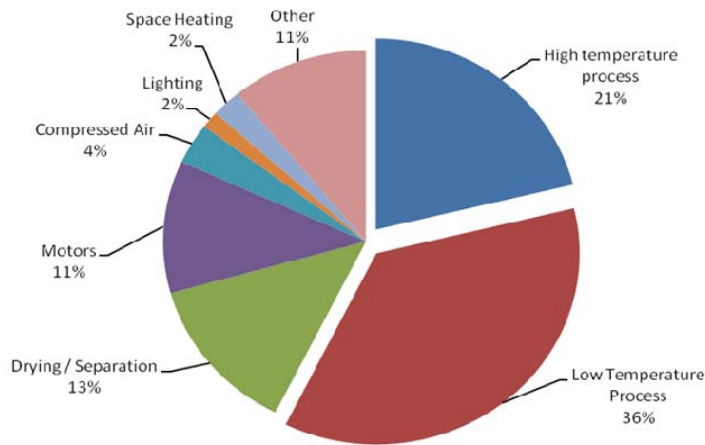

Figure 3.10: Energy use within industry by type of use in 2009 (BERR, 2009)

3.5.2 Role and importance of Energy Efficiency in Industry

Using energy more efficiently is not only a cost effective way of cutting carbon dioxide emissions but also improves productivity and contributes to the security of our energy supplies by reducing reliance on imported energy and ensuring our own and global energy resources are preserved (BERR, 2009). More importantly it helps to conserve the finite energy derived from non-renewable sources.

The reduction in energy consumption has historically been promoted within manufacturing as a means of saving money, with figures estimating that a 20% cut in energy costs represents the same bottom line benefit as 5% increase in sales (Carbon Trust, 2009). More importantly, whilst historic energy reduction measures have been borne out of the need to improve profitability (Ptasinski *et al.*, 2006), future improvements will be driven by the need to avoid taxations and levies. A study conducted by the International Energy Agency (IEA, 2008a) showed that over the long term, savings from improved energy efficiency are even more significant; without the energy efficiency improvements that have been implemented energy use would have been 58% higher in 2005 than it actually was. However the effectiveness of energy efficiency improvements have also decreased between 1990 and 2005 (as seen in Figure 3.11).

According to IEA (2008a), the application of proven technologies and best practices on the global scale could save between 25 exajoules (EJ) and 35 EJ of energy per year (1.9Gt CO₂ to 3.2Gt CO₂ emissions per year), which represents 18-26% of current primary energy use in industry. From the industrial aspect, a study by Worrell *et al.* (2009) showed that there are important benefits of energy efficiency and productivity. A methodology for assessing productivity benefits of energy efficiency investments was proposed which was incorporated into assessments of energy saving potential across an industry. There are numerous policies and measures e.g. Carbon Reduction Commitment Energy Efficiency Scheme (Carbon Trust, 2010a) and Climate Change Program (DEFRA, 2008) to ensure that energy efficiency in businesses are encouraged. Performance indicators like the Energy Efficiency Accreditation Scheme by the Carbon Trust recognises achievements in reduced energy use by leading organisations in industry, commerce and the public sector.

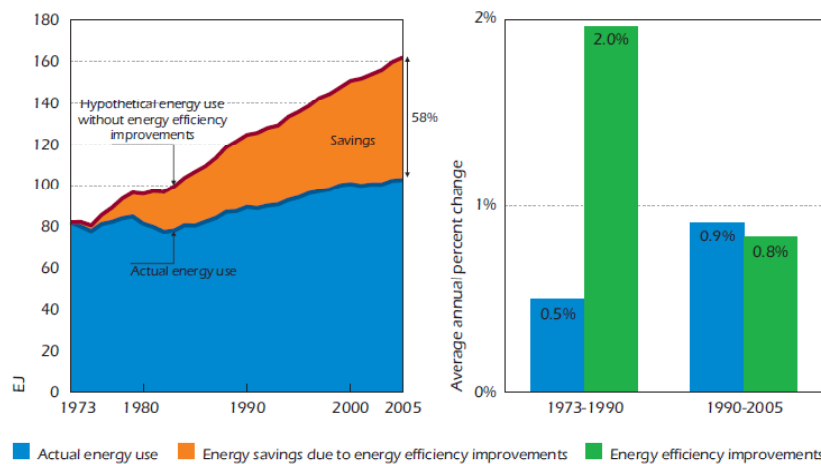

Figure 3.11: Long-term energy savings from improvements in energy efficiency (IEA, 2008b)

3.6 Energy Legislation and Economic Measures

On an international level, the International Organisation for Standardization (ISO) has recently approved ISO50001 as a draft standard and is expected to be published as an International Standard by late 2011 (ISO, 2010). The ISO50001 standard on energy management builds on the British Standard EN16001 for Energy Management Systems and will establish a framework for industrial plants, commercial facilities or entire organisations to manage energy. It complements the ISO9001 (ISO, 2008) for quality management and ISO 14000 (ISO, 1998) family of standards for environmental management. The framework ensures that organisations have a credible and effective management process enabling them to achieve their energy reduction goals. According to ISO, the new standard will:

1. provide a framework for integrating energy efficiency into management practices
2. allow companies to make better use of existing energy-consuming assets
3. enable benchmarking, measuring, documenting and reporting energy intensity improvements
4. provide transparency and communication on the management of energy resources
5. encourage energy management best practices and good energy management behaviours
6. evaluating and prioritizing the implementation of new energy efficient technologies
7. provide a framework for promoting energy efficiency throughout the supply chain.

The European Union (Commission of the European Communities, 2007) has set up the Strategic Energy Technology Plan (SET-plan) to reduce greenhouse gas emissions, increase sources of renewable energy and reduce primary energy use within the EU by 2020. There is a strong emphasis on reducing energy consumption and eliminating energy wastage so as to improve the competitiveness of the EU economy, the security of the energy supply and CO₂ reduction (Park *et al.*, 2009). In order to meet the objectives set out in the plan, the EU has proposed policies of minimum energy efficiency standards and rules on labelling products (The European Commission, 2010a) and the energy performance of buildings (The European Commission, 2010b).

A directive on establishing the framework for setting eco-design requirements (such as energy efficiency requirements) for all energy using products in the residential, tertiary and industrial sectors has been adopted through the eco-design of Energy using Products (EuP) Directive 2005/32/EC (The European Commission, 2005). The EuP Directive aims to improve the environmental performance of products throughout their life cycle by systematically integrating the environmental aspects at the initial stages of the product design. Manufacturers who are covered by the directive would need to ensure that their products meet the energy efficiency and environmental standards. With the implementation of the EuP Directive, the energy efficiency of production systems and processes may be regulated legally as well as play an important role in the product's success in the EU market.

In the U.S, a joint program of the U.S Environmental Protection Agency and the US Department of Energy –the Energy Star provides guidelines for the energy efficiency. Products that meet the energy efficiency requirements are awarded with an Energy Star label. These labels are now slowly being extended to more complex products such as cars and even buildings through the green building certification system called Leadership in Energy and Environmental Design, LEED. The Energy Star program also helps industrial manufacturers improve their energy management through the provision of tools such as assessment matrices and indicators. Recently the US Council for Energy-Efficient Manufacturing, U.S. CEEM, (2010) have implemented the Superior Energy Performance (SEP) initiative. SEP provides industrial facilities with a road map for achieving continual improvement in energy efficiency while maintaining competitiveness. Under the SEP initiative, industrial facilities are required to conform to

various energy management standards, system assessment standards and measurements and verification protocols, thus indicating a definite trend towards evaluating energy consumption of production lines, plants and companies.

The biggest catalyst for change currently affecting UK industry is that of the Climate Change Act 2008 making the UK the first country in the world to have a legally binding target of at least an 80% cut in greenhouse gas emissions by 2050 and a reduction in CO₂ emissions of at least 26% by 2020 (DECC, 2008). Within the UK, the manufacturing sector continues to produce significant amounts of CO₂ emissions, and as such, several incentives and accreditation schemes have been set up to encourage businesses to manage their energy use more efficiently. The Climate Change Levy (CCL) was introduced in 2001 to encourage improved energy efficiency and reduced greenhouse gas emissions. Climate Change Agreements (CCAs) were introduced alongside the CCL which provide an 80% discount on the levy if challenging targets are agreed and met for improving energy efficiency or reducing greenhouse gas emissions. The CCAs will have an impact on energy-intensive industries through providing an incentive to both reduce energy consumption through energy efficiency measures and reduce carbon emissions through reducing energy consumption and generating energy through renewable and low carbon means (ARUP, 2010). To significantly reduce UK carbon emissions not covered by other legislation, the mandatory Carbon Reduction Commitment Energy Efficiency Scheme, CRC (Carbon Trust, 2010a) was implemented in 2010 and covers all large non-energy intensive organisations in the public and private sector. Those covered by the scheme will need to measure and report their carbon emissions annually and are ranked in a CRC performance league table. It is anticipated that the scheme will cut 1.2 million tonnes of carbon per year by 2020.

Accreditations have also been set up by the Carbon Trust to generate greater product awareness amongst consumers and allow businesses to demonstrate commitment to manage and reduce the environmental impacts of their products. For example the Carbon Reduction Label (Carbon Trust, 2010b) requires companies to calculate the carbon footprint of the product or service to identify the areas of highest emissions and energy intensity throughout its life cycle. The certification is done in accordance with the Publicly Available Specification, PAS, 2050 that provides an assessment of life cycle greenhouse gas emissions of goods and services (British Standards Institution, 2010).

3.7 Chapter Summary

It is apparent that energy plays a key role in society and is essential for modern life. Energy demands are set to increase and our dependence on non-renewable sources of energy, compounded by the urgency to mitigate greenhouse gas emissions means not only do we have to switch to using renewable sources like wind and solar, we also have to be more efficient with the way in which energy is used. It is projected that fossil fuels will still remain a significant portion of our energy source in the near future. Globally and in many countries, the manufacturing sector is one of largest consumers of energy; as reported by the IEA, energy supply and generation accounts for majority of the carbon emissions, as such in the near future, energy optimisation and rationalisation will be a one of the main avenues for carbon reduction. Internationally, governments are tightening and increasing the number of energy related legislation to improve energy efficiencies and reduce energy consumption within businesses and industry. With UK's commitment to cut its carbon emissions by 80% by 2050, there will be increasing pressure for companies and businesses to reduce and limit their carbon emissions. The government has already started by implementing numerous energy related legislation and incentives such as the Carbon Reduction Commitment Energy Efficiency Scheme and Energy Use in Products Directive for businesses to manage and conserve energy use within their facilities but also create products that are low energy users throughout their life cycle.

Chapter 4 Review of Energy Related Research in Industrial Systems

4.1 Introduction

With the recent concern in climate change and rising energy costs, there has been a proliferation of research on reducing and managing energy consumption within industry. This chapter provides an overview on the various research that has been conducted on measuring, analysing and modelling energy consumption within manufacturing. The research reported in this thesis can be categorised into two main approaches: 1) from a product designer's perspective and 2) from a manufacturer's perspective. The chapter begins by introducing these approaches, and then goes into more detail in each of those perspectives, finally concluding on how the existing body of work would complement the research reported in this thesis, with the research gaps identified.

4.2 Overview of Energy Related Research in Industrial Systems

Industrial systems encompass the design of products, the making of the products as well as the business of selling the products. As seen in Chapter 3, much of the greenhouse gas emissions are the result of energy use. It has been suggested that the industrial system can account for 30% or more of greenhouse gas generation in industrialised countries (Evan *et al.*, 2009). With concerns over climate change, the need for industrial systems that are green and sustainable has never been greater and consequently there has been a growing body of research exploring opportunities for energy reduction in this area.

There are two approaches to analysing energy flows within industrial systems –

- 1) from a product designer's perspective, and
- 2) from a manufacturer's perspective.

Comment [Y2]: Intro to designers and manufacturer's perspective

The energy consumption of a product over its life cycle is commonly evaluated based on the use of Life Cycle Assessments. Depending on the accuracy required, various methodologies for establishing energy consumption for a product have been developed and will be discussed in Section 4.3.

From a manufacturer's perspective, much work has been reported on the energy efficiency of manufacturing processes and production machines. It is increasingly recognised that a holistic view of the manufacturing system (one that includes operation parameters and the plant environment) is required for the efficient design and management of products. As such, recent research has focused on collecting and integrating energy data from various aspects of the manufacturing system into a single platform for greater energy improvements and strategic decision making. Section 4.4 will look at the complexities and issues of analysing energy flows from a manufacturer's perspective. This includes looking at energy consumption of the overall plant, manufacturing processes and production equipment. There are different challenges with each approach. Herrmann *et al.* (2007) notes that energy data becomes more complex and difficult to reference (see Figure 4.1) as the level of integration within a product or system increases. Typically, simple products such as a light bulb are the easiest to assess whilst plants and companies within manufacturing systems are the most complex and therefore difficult to benchmark.

Comment [Y3]: Manufacturers perspective

Comment [Y4]: Last edit

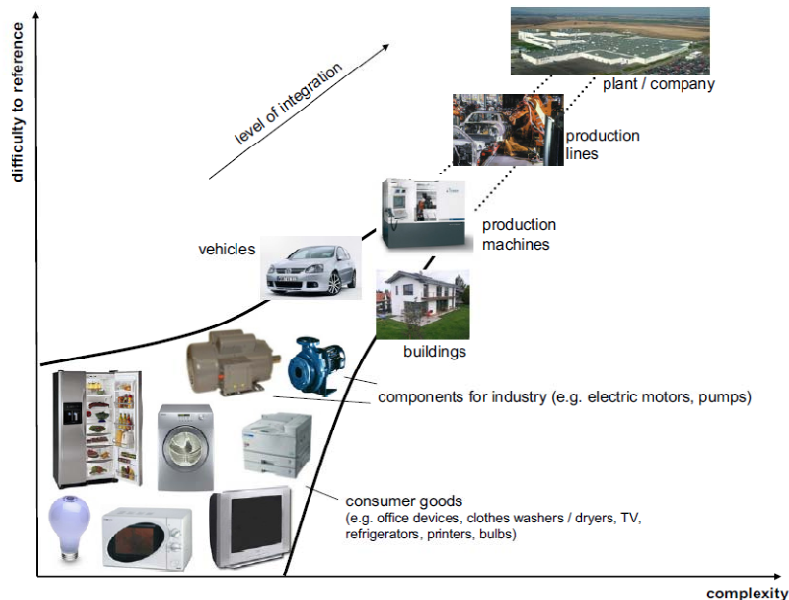

Figure 4.1: Complexity and difficulty of assessing energy within an industrial system (Herrmann *et al.* 2007)

4.3 Energy Research from a Product Designer's Perspective

A widely accepted method for a product based environmental evaluation is Life Cycle Assessment (LCA) which has also been internationally standardised through the ISO14000 (ISO, 1998) series. The analysis of the life cycle of a product involves looking at the upstream processes of the product and considers all phases required for the products' existence. LCA holistically evaluates the environmental consequences of a product system by quantifying the energy and materials used and wastes released to the environment, and assessing the environmental impacts of these inputs and outputs, with energy consumption typically being one of the main considerations within a LCA study (Hauschild *et al.*, 2005). A detailed explanation of the LCA framework and procedure as well as an overview of available methods and tools for tabulating and compiling associated emissions and resource consumption data in a life cycle inventory (LCI) has been detailed by Rebitzer *et al.* (2004).

The life cycle approach has formed the basis for most of the energy tools suitable for a product designer. Some tools are more holistic, focusing on the overall life cycle, whilst some are more specific and may only focus on a particular phase. Table 4.1 provides an overview of the energy related research work that uses LCA tools and the respective phases that were considered within the work.

With the aid of commercial LCA software like SimaPro5, Kantardgi *et al.* (2006) have shown that it is possible to successfully model environmental impacts due to energy use in the process stages of brick manufacture. However the most researchers found the inventory analysis that is required as part of a LCA to be too complex and requiring a great deal of effort (McAloone, 2000; Guinée *et al.*, 2002; Fitzgerald *et al.*, 2007; Knight and Jenkins, 2009). This is partly due to a lack of consensus among practitioners on various LCA issues and techniques. Such a study is often time consuming and expensive, further exacerbated by the lack of comprehensive publicly available data sources, in particular on various sources of energy consumption during a product life cycle. Thus there have been developments to simplify the LCA methodology by narrowing the scope of the study or by focusing on just a particular aspect e.g. material use, energy use or CO₂ emissions. To reduce the data intensive nature of processing the databases LCAs are often integrated with the help of software which is discussed in Chapter 5.

Life cycle Phases considered	Focus	Type of Tool Used	Reference	Energy Data based on
All	Energy	Streamlined LCA	Duque Ciceri <i>et al.</i> , 2010	Mass
All	Energy	Streamlined LCA, Sustainable Environmental Performance Indicator	De Benedetto and Klemes, 2009	Mass
All	Energy and CO ₂ emissions	Streamlined LCA , CES EcoSelector	Ashby <i>et al.</i> , 2008	Mass
All	Energy	Life Cycle Energy Analysis, LCEA	Fay <i>et al.</i> , 2000 Sullivan and Hu, 1995	Mass
All	Energy and Cost	Life Cycle Energy Analysis, LCEA	Keoleian and Lewis, 1997 Fitch and Cooper, 2010	Mass
All	Energy	Cumulative Energy Demand, CED	Gurzenich and Wagner, 2004 Patel, 2001	Mass
Material extraction and processing	Energy and CO ₂ emissions	LCA	Higgs <i>et al.</i> , 2010	Mass
Material extraction and processing	Energy	LCA	Graedel and Allenby, 1996	Mass
Manufacturing	Energy	LCA	Kantardgi <i>et al.</i> , 2006	Mass
Manufacturing	Energy	Component Manufacturing Analysis	Mori, <i>et al.</i> 2000	Mass
Manufacturing	Energy	Hybrid analysis combining process and economic input-out methods	Williams, 2004	Mass and unit process
Use	Energy	Energy indicators	Moenne-Loccoz <i>et al.</i> , 2010	Mass
End-of-life	Energy	Static and Dynamic Life Cycle Energy Analysis, LCEA	McLaren <i>et al.</i> , 1999	Mass

Table 4.1: Overview of research work from a Product perspective

Duque Ciceri *et al.* (2010) improved on the LCA methodology and developed a tool that can be quickly and transparently used to estimate the energy requirements and checked against an existing LCI so that new products can be estimated at the design stage. The tool uses the product's bill of materials and the knowledge on how these materials are processed to estimate the material's embodied energy and manufacturing energy for a product. A value range on the energy requirements of a product system is derived through the sum of all the energy inputs (which were estimated or established from databases) into a product system from the beginning of its life, including the extraction of materials, processing and the manufacture of the final product. They noted that the accuracy of the results will improve with the level of manufacturing data available.

To further simplify the process of conducting an LCA and its outputs, De Benedetto and Klimes (2009) used specific sustainability indicators (footprints) which were then translated into a graphical representation designed to provide a single indicator named the Sustainable Environmental Performance Indicator. One of the footprints that were considered was the energy footprint which takes into account different energy supplies as related to different demand categories, such as heating and hot water production, process energy, electricity and traffic. Energy footprints have also been used by Ashby *et al.* (2008) to provide a quick estimation of energy usage on a per mass basis for the material and processing, and consequently the product.

An example of an LCA with a focused scope on energy is the Life Cycle Energy Assessment (LCEA) which is based on the guidelines and methodology in a typical LCA but uses energy as the only measure of environmental impact. Typically the use of LCEA is not to replace a broader environmental assessment method, such as LCA, but to facilitate decision making concerning energy efficiency (Fay *et al.*, 2000). Comparing the energy required in the manufacture of a product to its operational energy for example can indicate potential life cycle energy efficiency and conservation strategies. Keoleian and Lewis (1997) showed that insulation on a kettle would require additional embodied energy cost – energy to make the insulation – but savings in operational energy will provide greater savings in the longer term. The Ford Motor Company often considered life cycle energy at the system level during the development of automobiles, rather than at the component level to ensure that energy consumption is

minimised across the life cycle (Sullivan and Hu, 1995). Figure 4.2 shows the typical energy flows throughout the life cycle of a product.

LCEAs are also useful for distinguishing the alternative solutions or technologies in terms of energy performance as well as aiding material selection by estimating life cycle energy of a component during the material selection process as demonstrated by Fitch and Cooper (2010). They compared LCEA with two different material energy analysis methods: Energy Content (EC) by Ashby (1992) and Lifetime Energy Consumption Index (LEC) by Kampe (2001) and found that LCEAs were still the most thorough. A detailed discussion on the use of LCA for energy analysis and management is detailed by Udo de Haes and Heijungs (2007).

Another form of streamlined LCA is the Cumulative Energy Demand (CED) method where the accounting of energy and material inputs is seen as part of an inventory analyses and the calculation of CED is a rough form of impact assessment. Gürzenich and Wagner (2004) used CED to establish the energy required by the production of photovoltaic in Europe. However much of the energy data used has been based on previous LCA studies. Patel (2001) who applied CED on products from the organic chemistry industry recommend using data from consistent and independent sources to avoid distorted conclusions from large data ranges.

Some researchers have simplified the LCA methodology by focusing on a specific phase for their energy assessments. For example Higgs *et al.* (2010) have specifically focused on the energy and CO₂ impacts with bringing materials to the high purity grade that is often required for semiconductor manufacturing.

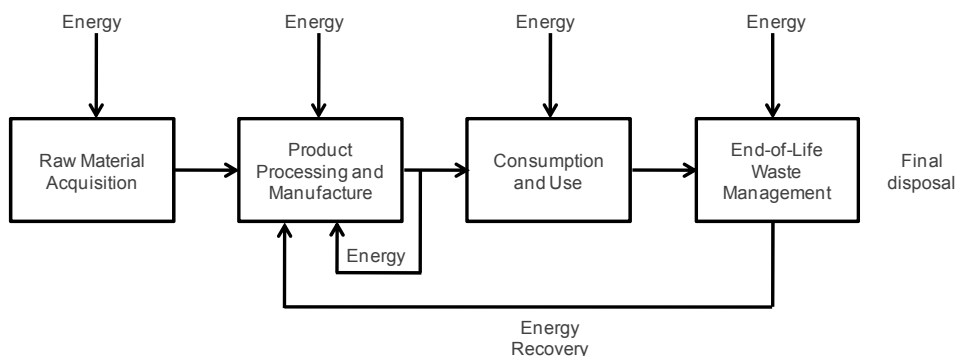

Figure 4.2: Energy flows at various stages of the life cycle (Fay *et al.*, 2000)

Graedel and Allenby (1996) also demonstrated how to calculate, based on process parameters, the energy consumed in manufacturing a material and present a general approach of minimising energy use in an industrial facility. Mori *et al.* (2000) have developed a new type of LCI method called Component Manufacturing Analysis (CMA) that is easy to implement and less arbitrary. CMA requires the identification of all product components and their associated weights which are then entered into a factory type database to establish the energy use during the production phase. The energy data for the materials production was derived from existing databases and also based on material masses.

Despite these simplified techniques, it is commonly reported that the incompleteness of process data is a problem for LCAs (Suh *et al.*, 2004; Williams, 2004; Dixit *et al.*, 2010). To overcome missing data, Williams (2004) used a hybrid assessment that combines process and economic input-output methods to estimate the energy required to manufacture a desktop computer. Where data on materials and energy used to make the components of the product is unavailable, the energy use is estimated by first estimating energy consumption of the global semiconductor industry and then allocating a portion used in production of a desktop computer according to the value of semiconductor shipments used that computer. However the inherent assumptions in such methods make the results unreliable.

Moenne-Loccoz *et al.* (2010) have proposed using energy indicators to assess and track the energy consumption of electronic equipment during the Use phase with the aim of helping designers create more energy efficient electronic products. Energy use at the End-of-life phase has also been investigated. McLaren *et al.* (1999) conducted a static LCEA and dynamic LCEA on the End-of-life of mobile phones, and found implementing take back and recycling are generally beneficial to the environment. If the product sales follow predicted trends, take back rates must be substantial before the total system energy requirements starts to decline in real terms.

One of the main drawbacks of life cycle analysis tools is the assumption that energy requirements for manufacturing processes are constant, however studies conducted by Gutowski *et al.* (2006) have shown that the energy requirements can vary significantly base on process rate amongst other production parameters. These considerations are discussed further in the next section.

4.4 Energy Research from a Manufacturer's Perspective

A more formal and structured approach to analysing a manufacturing system is to decompose the system hierarchically. A variation of the Shop Floor Production Model as developed by ISO (1990) is used to categorise research into various levels. The adapted model has five levels, ranging from a high level view to a specific scope:

1. Enterprise
2. Facility
3. Production/Machine Cell
4. Machine
5. Tool-chip

On the highest level, manufacturing enterprises extend beyond the walls of the factory that just produces goods; instead it encompasses a range of activities from the supply chain of materials or components, to the logistics of the finished product. This involves a network of production sites, suppliers, inventory hubs as well as sales and distribution centres. Strategic decisions are often taken on this level and the activities are usually concerned with supply chain management, sales and marketing, research and development and integration of various plants. Energy flows involve the various interactions within the supply chain.

The next level is the manufacturing facility level. Energy consumption on this level is mainly from an infrastructure such as a single manufacturing site. Considerations like lighting, heating, ventilation and air-conditioning (HVAC) are taken into account.

The next level in is the production/machine cell level, which includes activities such as planning, production engineering and management, supply of materials resources, transport waste material processing and maintenance. Energy flows are closely related to the running of these activities which may be affected by production plans, scheduling times and parameters.

On a machine level, the activities would involve the operation of the equipment and supporting processes that are required for the transformation of material to occur. Energy analysis would be focused on energy consumed by the equipment and the

auxiliary equipment needed to support the main process. Machine energy efficiencies are also a main concern here.

On the last and most focused level is the tool-chip level which represents the actual transformation process itself. This involves the mechanical and chemical knowledge of the process in order to establish the theoretical energy consumption values of the work being carried out. Figure 4.3 provides a summary of the activities and areas of consideration within each level.

Vijayayaghavan and Dornfeld (2010) also stated that manufacturing systems can be studied at different levels. They suggested that at each level of analysis, there is a corresponding temporal scale of decision making which ranges from several days at the enterprise level to a micro-second at the tool-chip level. The range of variation in the analysis and temporal scales along with the types of decisions that are made at each level is shown in Figure 4.4. Herrmann and Thiede (2009) also highlighted the need for different approaches to improve energy efficiencies within different level.

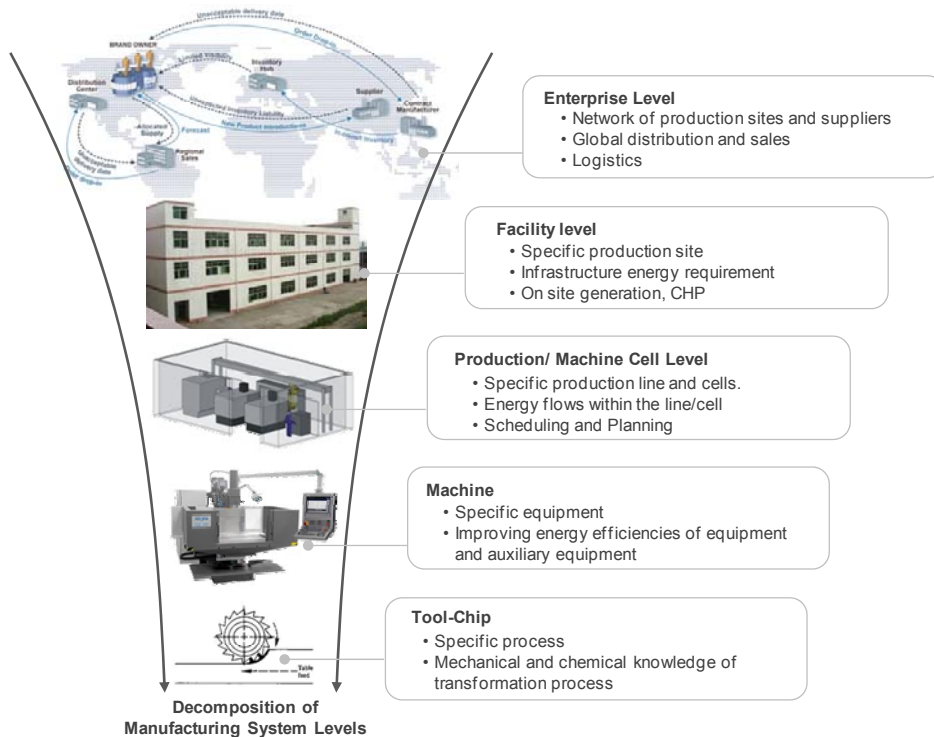

Figure 4.3: The different levels within a manufacturing system and the respective areas of research commonly conducted.

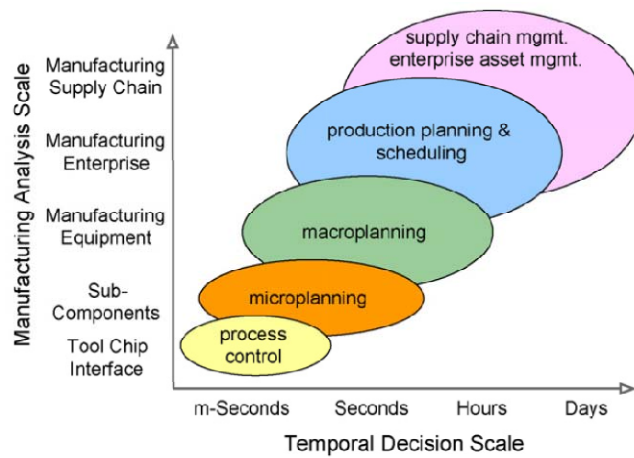

Figure 4.4: Level of analysis of manufacturing with temporal decision scales (Vijayayaghavan and Dornfeld, 2010)

4.4.1 Energy Research on an Enterprise level

Much of the energy consumed on an enterprise level is from logistics. Kara and Manmek (2010) found that supplier location was a significant factor that can increase or reduce the embodied energy of the raw materials, and that this embodied energy could be reduced by selecting local suppliers and avoiding use of road transport for moving the high quantities of raw materials over long distances. Kara *et al.* (2010) details a methodology for assessing the impact of global manufacturing on the embodied energy of the products. They studied six different products manufactured from various raw materials in a global manufacturing network and found that product, material and key supply chain parameters played a crucial role. In another study, Pearce *et al.* (2007) used Google Maps to optimise the embodied energy of transportation to enable manufacturers to optimise the life cycle of their products by minimising embodied energy of transportation.

The supply chain structure also influences the embodied energy of the product. Products that use recycled materials or reused components require less energy as less virgin material needs to be extracted and remanufacturing pathways avoids repeating manufacturing steps with characteristically high energy consumption and environmental emissions. Seliger *et al.* (2006) showed that less energy consumption is required for a phone that is remanufactured, than for a phone that has been sent to a landfill, over the production, use and end-of-life phase. The results indicated that the difference between

landfilling and remanufacturing a mobile telephone represents approximately 10 days of energy consumption for the average German household and 9 months of CO₂ sequestration potential for an average tree.

4.4.2 Energy Research on a Facility level

Two approaches can be considered when analysing the energy consumption of a factory with the aim of improving energy efficiency: the top-down and the bottom up approach. The top-down approach aims at allocating the consumption among different users in the factory which helps to identify the main drivers and in turn providing a basis for more detailed study in a specific area. Conversely, the bottom-up approach aims at thermodynamically modelling the energy consumptions of the different process operations in order to recalculate the energy consumption of the factory by summing up their different contributions (Muller *et al.*, 2007). The advantages and disadvantages of both approaches are summarized in Table 4.2.

	Advantages	Disadvantages
Top-down	<ul style="list-style-type: none"> • Low cost • Simple model • Easy monitoring • Easy forecasting • Flexible • Minimal Maintenance 	<ul style="list-style-type: none"> • Require statistical expertise • Require data history • No efficiency assessment • High level modelling • No modelling of efficiency measures
Bottom-up	<ul style="list-style-type: none"> • Based on equipment thermodynamics • Good accuracy • Clear picture of energy usage • No data history required • Efficiency assessment • Modelling of efficiency measures 	<ul style="list-style-type: none"> • High level of metering needed • Time-consuming study • High data entry requirement • Difficulties in forecasting • High cost of use/maintenance • Based on perfect operation

Table 4.2: Advantages and Disadvantages of the top-down and bottom-up method by Muller *et al.* (2007)

Research on this level primarily focuses on modelling and reducing the energy consumed by infrastructure and other high-level services such HVAC and lighting, which are responsible for maintaining the required product conditions and environment as well as the building design. Table 4.3 provides an overview of the research conducted on a facility level.

As HVAC systems are one of the main energy consumers in the building, there has been much focus on reducing energy consumption in these areas. Fumo *et al.* (2009) and Mills *et al.* (2008) both presented technical opportunities for reducing energy

consumption in high-tech facilities. Reductions can be achieved through energy efficiency by improving heating, air-conditioning and ventilation-efficiency upgrades as well green power purchases. As for lighting systems, Ryckaert *et al.* (2010) have proposed target values for lamps by taking into account basic lighting comfort requirements. Voluntary and mandatory programs (ranging from labelling strategies to building standards) such as the Energy Star and the LEED (Leadership in Energy and Environmental Design) are also helping companies achieve greater efficiency levels (Boyd *et al.*, 2008).

The reduction of energy consumption in a building can also be achieved through better building design. Harvey (2009) reviewed the literature concerning the energy savings that can be achieved through optimised building shape and form, improved building envelopes, improved efficiencies of individual energy using devices, alternative energy using systems in buildings, and through enlightened occupant behaviour and operation of building systems. He found that the provision of a high performance envelope is the single most important factor in the design of low energy buildings, providing up to 75% savings without costing more for construction as it eliminates the need for mechanical heating and cooling equipment.

There is a distinct lack of manufacturing energy performance indicators (EPI) and the difficulties of modelling 'plant level' energy consumptions (Boyd *et al.*, 2008). In energy management program development, benchmarking energy is essential yet it was noted that most industries have not benchmarked energy use across their plants. Benchmarking enables companies to determine if better energy performance could be expected. The task is further complicated by incorporating changing weather and production which are major drivers of plant energy use. Kissock and Eger (2008) have attributed various factors such as temperature, production and utility billing data to a single equation using regression models and are able to provide a clear breakdown on potential energy savings. On a more generic level Hernandez *et al.* (2008) reported on the development of energy performance benchmarks and building energy ratings for non-domestic buildings. They outlined a methodology to develop energy benchmarks and rating systems starting from the very first step of data collection from the building stock.

Cakembergh-Mas *et al.* (2010) did an economic assessment of an energy enhancement program for a Kraft wood pulping mill and compared 3 cogeneration systems: single back pressure steam turbine, single steam condensing turbine and a two turbine system. They found that the single back-pressure steam turbine had the shortest payback time but the combination of two turbines produced more power and give higher benefits in the long term.

Energy Consumption on a Facility Level Perspective		
Aspect	Reference	Research Area
Heating, Ventilation and Air Conditioning	Mills <i>et al.</i> (2008)	Presented technical opportunities for reducing energy consumption in high-tech facilities. Reductions can be achieved through energy efficiency by improving heating, air-conditioning and ventilation-efficiency upgrades as well green power purchases
Lighting	Ryckaert <i>et al.</i> (2010)	Proposed a set of criterion for indoor lighting based on basic lighting comfort requirements, to help assess the energy efficiency of indoor lighting installation.
Building Design	Harvey (2009)	Found that the provision of a high performance envelope can providing up to 50-75% savings without costing more for construction as it eliminates the need for mechanical heating and cooling equipment.
Benchmarking energy consumption on a 'plant' level	Boyd <i>et al.</i> (2008)	Highlighted the distinct lack of manufacturing energy performance indicators (EPI) and benchmarking due to the difficulties of modelling 'plant level' energy
	Kissock and Eger (2008)	Presented multi variable piece-wise regression models to characterize baseline energy use as a method for measuring plant-wide industrial energy savings. It takes into account changing weather and production between the pre and the post retrofit periods. It uses readily available temperature, production and utility billing data
	Hernandez <i>et al.</i> (2007)	Reported on the development of energy performance benchmarks and building energy ratings for non-domestic buildings. They outlined a methodology to develop energy benchmarks and rating systems starting from the very first step of data collection from the building stock
Onsite energy generation	Cakembergh-Mas <i>et al.</i> (2010)	They compared 3 cogeneration systems and found that the single back-pressure steam turbine had the shorted payback time but the combination of two turbines produced more power and give higher benefits in the long term.

Table 4.3: An overview of the research on a facility level

4.4.3 Energy Research within Production/Machine Cell

Much of the work on the production level involves process planning and process routing for improved energy performance. Due to the complexity of process flow decisions, most research focuses on costs and cycle times. There is a lack of tools for optimizing process flow based on sustainable development objectives, and those that were proposed have few practical results (Tan *et al.*, 2006). In an attempt to bridge this gap, Tan *et al.*, (2006) combined manufacturing process planning and environmental impact assessments using check list analysis and proposed an optimal decision making method for new components that includes energy consumption as part of the sustainable development evaluation, see Figure 4.5.

Various environmental measures can be used to develop an environmental process planning system that works with conventional process planning methodologies to evaluate trade-offs between environmental and productivity requirements (Krishnan and Sheng, 2000). Multi objective analysis can be used to support green process planning (Yeo and New, 1999) to optimise the raw materials, secondary materials and energy consumption, and other environmental impacts (He *et al.*, 2005). Using databases and model repositories, the integration of the optimisation of energy consumption of processes as part of the process selection algorithm in a process planning program is possible as demonstrated by He *et al.* (2007).

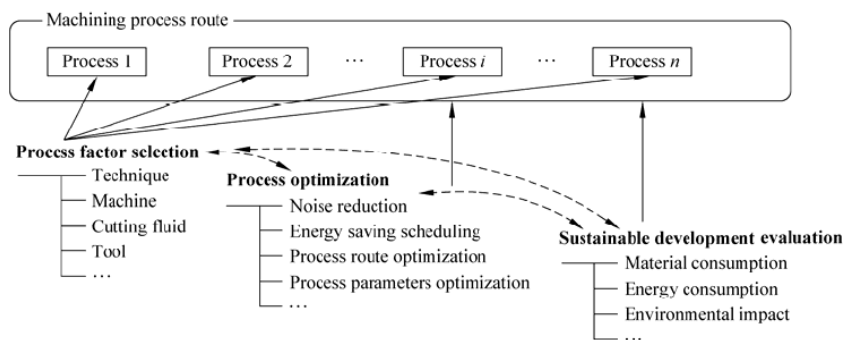

Figure 4.5: Optimization decisions for production process planning in terms of sustainable evaluation (Tan *et al.*, 2006)

4.4.4 Energy Research associated with Production Machines and Equipment

The research targeting energy consumption at the production machinery and equipment level has concentrated on individual equipment, machinery and workstations within a production system. Until recently, minimising the energy consumption was hardly a priority for many machine designers; for most functionality, cost, accuracy and safety were more important. With increasing energy prices and a focus on environmental impact, the operational energy consumption is now a point of consideration for the end user and, as such there is an increased need to measure and evaluate energy consumed by manufacturing equipment (Devoldere *et al.*, 2007; Hauschild *et al.*, 2005; Jovane *et al.*, 2003). Given that machining processes are used in manufacturing the tooling for many consumer products, improving the energy efficiency of machining-based manufacturing systems could yield significant reduction in the environmental impact of consumer products (Vijayaraghavan and Dornfeld, 2010).

It has generally been agreed that the power demand of production equipment, in particular machine tools, consist of a constant and variable component. The constant power can be attributed to the computer, fans, lighting etc. of the machine tool. This component is independent of process parameter selection. This is further discussed in Section 4.5.4.1. The variable power demand on the other hand is dependant on process parameter selection and can be attributed to the spindle or the drives of the table axes which will be discussed in Section 4.5.4.2.

4.4.4.1 Constant Energy Consumption of Production Machines

Specific Energy Consumption, SEC, of processes is typically used to determine the minimum amount of energy required to remove a certain volume of material. However, as reported by Dahmus and Gutowski (2004), the energy requirement of the process is much higher in actual production. In machining for example, in addition to providing energy to the tool tip, energy must also be provided to power auxiliary equipment such as work piece handling equipment, cutting fluid handling equipment, chip handling equipment, tool changers, computers and machine lubrication systems. In some cases, the energy requirements of the auxiliary equipment can far exceed the actual cutting requirements. The energy consumption is therefore not largely determined by the cutting operation but dominated by the basic power consuming components. This energy is mostly constant and independent of whether or not a part is being produced.

A study conducted by Dahmus and Gutowski (2004) on three different milling machines with different auxiliary equipment capabilities, showed that depending on the machine model between 48%- 69% of the energy consumed is constant regardless of the load (See Figure 4.6). They categorised start-up energy use, such as for computers, fans and unloaded motors as “Constant Start-up operations” and energy used to position materials and load tools as “Constant Run-time operations”. It is expected that in the future greater automation and an increasing number of integrated machining equipment would mean a greater percentage of auxiliary energy consumption. As evident in another study on a large Toyota machining centre, it was found that as much as 85.2% of the energy used by machining equipment is constant, independent of whether or not a part is being produced (Gutowski *et al.*, 2005).

Coupled with equipment operation data, such as the number of hours the equipment is in different modes of operation and the power rating of equipment, the energy consumed during “Constant Start-up operations” and “Run-time operations” can be calculated based on the time the machining centre spent in each of those states. Dahmus and Gutowski (2004) have made a detailed description of the energy calculations of milling machines using this breakdown, the results are shown in Figure 4.7. They found that the Cincinnati Milacron spends over 70% of the time positioning, loading, and gauging the part. As a consequence, the energy consumption during non-production time is substantial and it should be reduced through organisational and technical measures.

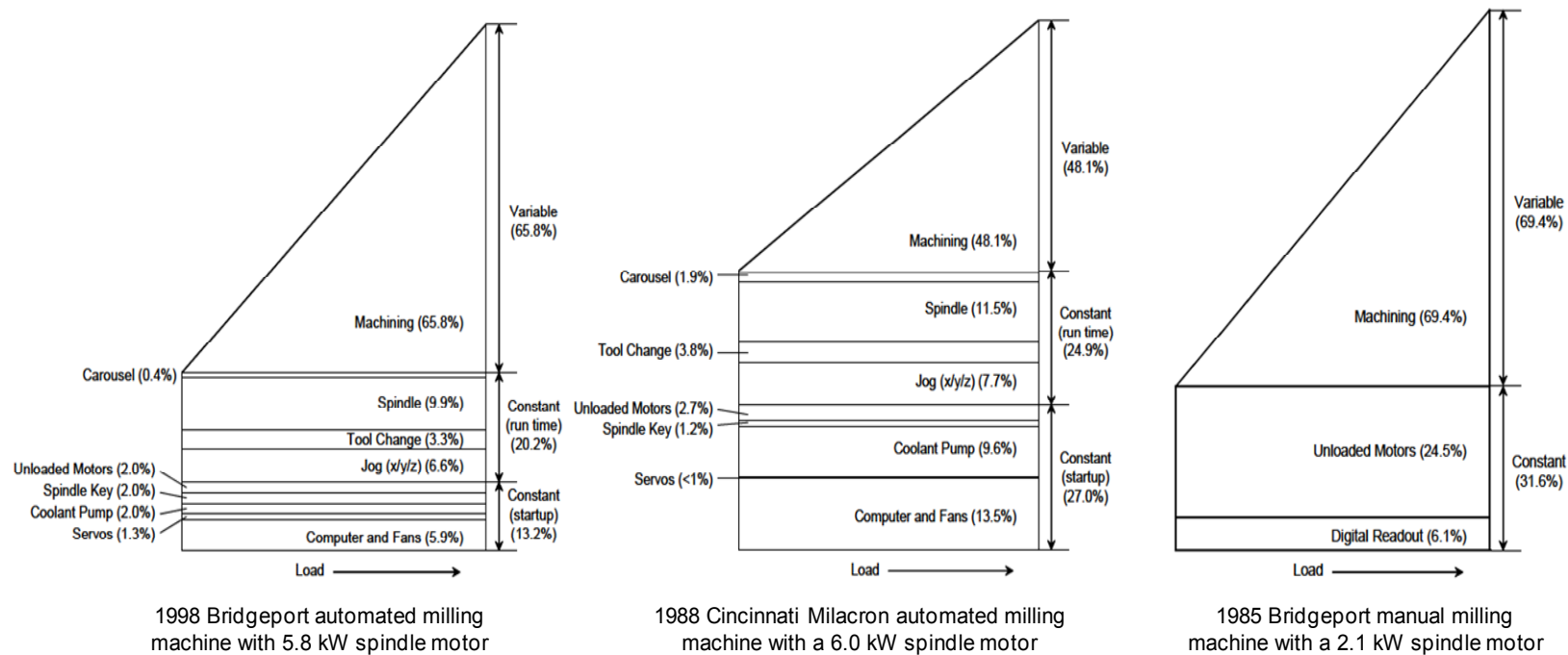

Figure 4.6: Machining energy use breakdown for various automated milling machine (adapted from Dahmus and Gutowski, 2004)

	Production Machining Center (2000)		Automated Milling Machine (1998)		Automated Milling Machine (1988)		Manual Milling Machine (1985)	
Energy Breakdown								
Constant start-up operations (idle)	85.2%		13.2%		27.0%		31.6%	
Run-time operations (positioning, loading, etc)	3.5%		20.2%		24.9%		0% (manual)	
Material removal operations (in cut)	11.3%		65.8%		48.1%		69.4%	
Energy Requirements								
Constant start-up operations (idle)	166 kW		1.2 kW		3.4 kW		0.7 kW	
Run-time operations (positioning, loading, etc)	6.8 kW		1.8 kW		3.1 kW		0 kW	
Material removal operations (in cut)	22 kW		5.8 kW		6.0 kW		2.1 kW	
Machine Use Scenario								
Arbitrary Number of work hours	1000 hours		1000 hours		1000 hours		1000 hours	
Machine uptime	90%		90%		90%		90%	
Machine hours (idle, positioning, or in cut)	900 hours		900 hours		900 hours		900 hours	
Percentage of machine hours spent idle	10%		35%		35%		65%	
Machine hours spent idle	90 hours		315 hours		315 hours		585 hours	
Active machine hours per 1000 work hours	810 hours		585 hours		585 hours		315 hours	
Machining Scenario								
Percentage of machine hours spent positioning	30%		60%		60%		70%	
Machine hours spent positioning	243 hours		351 hours		351 hours		221 hours	
Percentage of machine hours spent in cut	70%		40%		40%		30%	
Machine hours spent in cut	567 hours		234 hours		234 hours		94.5 hours	
Energy Use per 1000 work hours								
Constant start-up operations (idle)	149288 kWh		1038 kWh		3033 kWh		600 kWh	
Run-time operations (positioning, loading, etc)	5471 kWh		1033 kWh		1818 kWh		0 kWh	
Material removal operations (in cut)	6237 kWh		673 kWh		702 kWh		100 kWh	
Total energy use per 1000 work hours	160996 kWh		2744 kWh		5553 kWh		700 kWh	
Energy Used per Material Removed								
Material Machined	Aluminum	Steel	Aluminum	Steel	Aluminum	Steel	Aluminum	Steel
Material Removal Rate	20.0 cm ³ /sec	4.7 cm ³ /sec	5.0 cm ³ /sec	1.2 cm ³ /sec	5.0 cm ³ /sec	1.2 cm ³ /sec	1.5 cm ³ /sec	0.35 cm ³ /sec
Material removed per 1000 work hours	40824000 cm ³	9593640 cm ³	4212000 cm ³	1010880 cm ³	4212000 cm ³	1010880 cm ³	510300 cm ³	119070 cm ³
Energy used/Material removed	14.2 kJ/cm ³	60 kJ/cm ³	2.3 kJ/cm ³	10 kJ/cm ³	4.7 kJ/cm ³	20 kJ/cm ³	4.9 kJ/cm ³	21 kJ/cm ³

Figure 4.7: Energy analysis of four milling machines (Dahmus and Gutowski, 2004)

A similar study by Devoldere *et al.* (2007) on a 5-axis milling machine found that 65% of operation time was non-productive which accounted for up to 47% of the total energy consumption (see Figure 4.8). Fleschutz *et al.* (2010) conducted an energy simulation on 12 similar industrial robots within a workstation and found that the assigned operations strongly influenced the energy consumption of the respective robot. Even though the operating hours are the same for the robots, those that had more kinematic movements and little idle time resulted in energy consumptions that were double the other robots.

4.4.4.2 Variable Energy Consumption of Production Machines.

The variable energy consumption is dependent on the processing parameters. Diaz *et al.* (2009) varied the feed rates for a cutting process and found that the energy per unit manufactured increased at lower feed rates. This was also seen when using high speed machining compared to conventional machining mainly due to the decrease in processing time which offset the slight increase in power required machining at higher speeds. Rajemi *et al.* (2010) found that the cutting velocity and hence the cycle times strongly influenced the energy consumption of the machines. Three work pieces were machined on a lathe at different speeds and the percentage of the power use for the actual machining process increased with cutting speed.

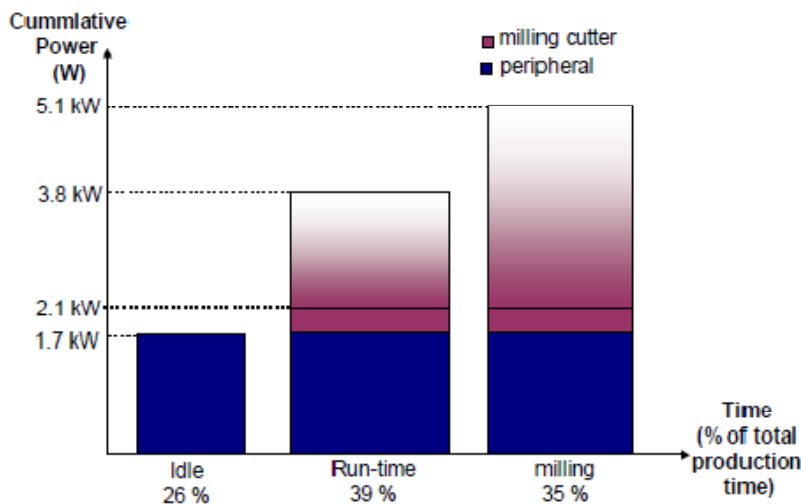

Figure 4.8: Relative energy consumption per production mode (Devoldere *et al.*, 2007)

Krishnan *et al.* (2009) have made some preliminary measurements and energy efficiency analysis of individual machines in different manufacturing processes such as injection moulding, compression moulding and sheet metal working. Their observations from the study are summarised in Table 4.4.

The operational use of a machine also affects the energy consumption of production machines. An early study on 10 different numerical control machines tools conducted by Filippi and Ippolito (1981) found that an average of only 60% of machining time was productive and as a result the full power of the machine was never exploited. Energy consumption can be reduced through implementing effective machining strategies that minimised non-productive times (Akbari *et al.*, 2001).

Process	Relationship of Energy requirements to processing parameters.
Injection Moulding	<ol style="list-style-type: none"> 1. Type and characteristic of the plastic (for instance each material has different melting temperature) 2. Design, complexity, and the size of the end product. The greater the pressure on the mould, the more energy is consumed. 3. Each technique used for shaping of the product has its own SEC, depending on heating, moulding and cooling. 4. The higher the quantity of production, the Lower the SEC 5. The cycle time determines how long the pump or electrical motor is switched on during the moulding process 6. Size of the machine 7. Frequency of use of the mould 8. Outside temperature (there is a 10% consumption in the summer)
Compression Moulding	<ol style="list-style-type: none"> 1. The SEC tends to be higher for lower flow rates and lower for higher flow rates 2. The final summary graphs also show how the machines perform with respect to each other while comparing SEC to flow rate/ throughput. 3. The general SEC values for M are between: 1-13 MJ/kg assuming grid efficiency of 33% 4. Across machines, it is observed that some machines have lower SEC values for a given throughput.
Sheet Metal working	<ol style="list-style-type: none"> 1. The SEC in sheet metal working is inversely proportional to the throughput. As the throughput increases the SEC reduces and vice versa 2. The SEC reduces as the total material processed increased, subject to flow-rate changes 3. The inverse relationship of the SEC to the throughput was also retained when the throughput changed either in the early stage or the middle stages of the entire measurement period.

Table 4.4: Observations of energy consumption and processing parameters (Krishnan *et al.*, 2009)

4.4.4.3 Deriving energy data from production equipment

Typically energy information can be estimated by summarizing the electrical energy consumptions of single machine components (pumps and engines) or through taking energy measurements of the auxiliary equipment with the use of energy metering systems (Herrmann *et al.*, 2007; Gutowski *et al.*, 2005). Alternatively the energy values can be derived from machine specifications from equipment manuals or vendors; or information given by the manufacturers. Most specifications have been shown to be accurate enough for rough analyses (Kalla, 2009), an example of a specification is shown in Table 4.5. As noted by Heilala *et al.* (2008), getting detailed data for manufacturing processes like turning, milling or welding is the real challenge, since parameters depend on the product. So where theoretical data is unavailable, it is also possible to determine the energy required by a process through empirical observations.

For a more holistic understanding of energy consumption of production equipment, some researchers have used energy profiles to identify the main energy consumers in machines for energy efficient production optimisation. As discussed earlier, the machines consist of several energy consuming components which generate a specific energy profile as an integrated system. The energy profiles include all machine components which are necessary to perform the machining. Generally energy profiles can be subdivided into fixed and variable energy consumption. The fixed energy consumption includes the energy requirements of machine components like pumps, control units and coolant which enable an operating state. The variable energy consumption of a production machine includes the required electrical energy for tool handling, positioning and actual cutting operation.

Specifications	TTC		
	TTC-630	TMC500	XR1500 HPD
Model number	TTC-630	TMC500	XR1500 HPD
Spindle Speed (Belted)	4000 rpm	6000 rpm	-
Spindle Motor power	15/20 kW	5/7 kW	-
X Axis Motor Power	208 kW	-	-
Z Axis Motor Power	2.8 kW	15000 rpm	375-7500 rpm (Gear Box)
Coolant Pump Motor Power	1 kW	40 hp	40 hp
ATC Motor Power	12.6 kW	34 hp	40 hp
Rapid Traverse (X,Y)	197 mm/min	1417ipm	1417 ipm
Rapid Traverse (Z)	630 mm/min	1417 ipm	1417 ipm
Total Driving Power	40 kW	787 ipm	787 ipm
Hydraulic Pump	1.1 kW	40 KVA	40 KVA

Table 4.5: Example of Machine Specifications of a TTC CNC machine including power rating of auxiliary equipment (Kalla, 2009)

The intensity of the variable electrical energy is highly influenced by process parameters such as cutting speed, specific material removal rate and specific stock removal volume and the use of cooling lubricants. The energy profile can be categorised into basic energy, idle energy and tip energy (Kalla *et al.*, 2009) as shown in Figure 4.9. The total energy consumption for the process is the sum of all three types of energy as shown in Equation 4.1, where power and time are as illustrated in Figure 4.9.

$$E_{total} = P_{basic} * (t_{basic}) + P_{idle} * (t_{idle}) + P_{milling} * (t_{milling}) \quad \text{[Equation 4.1]}$$

(Basic energy) (Idle energy) (Milling energy)

Where,

E_{total} is the total energy required for milling a part

P_{basic} is the power during the basic mode of the process

t_{basic} is the time which the process spends in basic, idle and milling mode

P_{idle} is the power during the idle mode of the process

t_{idle} is the time which the process spends idling and milling

$P_{milling}$ is the power during the milling mode

$t_{milling}$ is the time which the process spends milling

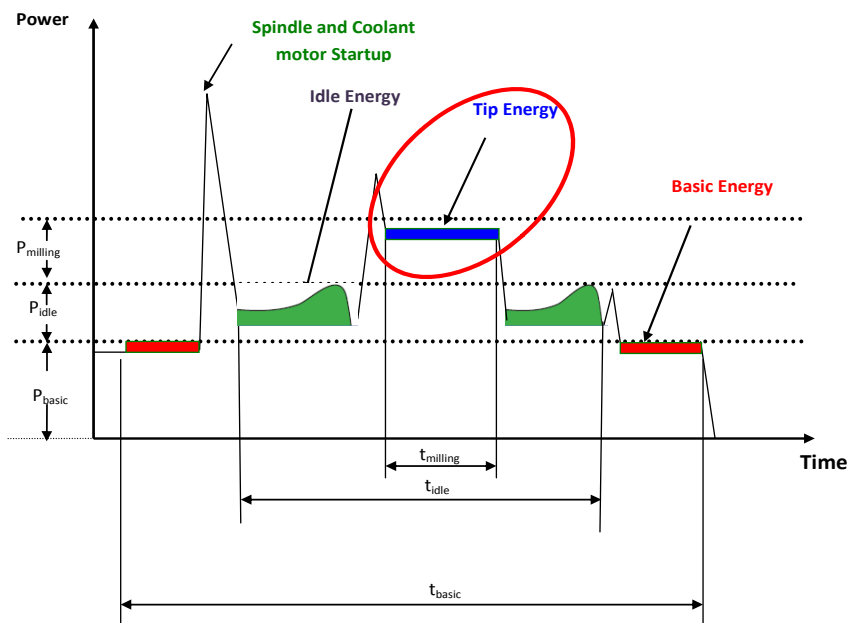

Figure 4.9: Determination of power characteristics and energy requirements of machine tools (Kalla *et al.*, 2009)

In a study of the energy profile generated by a grinding machine Herrmann *et al.* (2008) highlights the high energy demand of the air exhaust system as depicted by the sharp increase in power requirement seen in Figure 4.10. As a consequence, further measures such as reducing the operation mode or replacing air system components through more efficient technology can be applied to reduce the total basic power consumption. Furthermore, the energy profile shows that the exhaust air system substantially increases the power consumption to a short time maximum of 10 kW when started. A similar effect is visible with employing the cutting tool spindle.

Also using energy profiles, Vijayaraghavan and Dornfeld (2010) have proposed a framework based on event stream processing to temporally analyse the energy consumption and operational data of machine tools and other manufacturing equipment. This means that software is able to analyse energy load profiles and changes in the load patterns can intelligently interpret the events that have taken place. Figure 4.11 and Table 4.6 show the events that were analysed by the framework and the reasoning for the profiles. The integration of the software with real time data from energy meters and embedded process sensors in the future would provide additional support in obtaining empirical data of manufacturing processes.

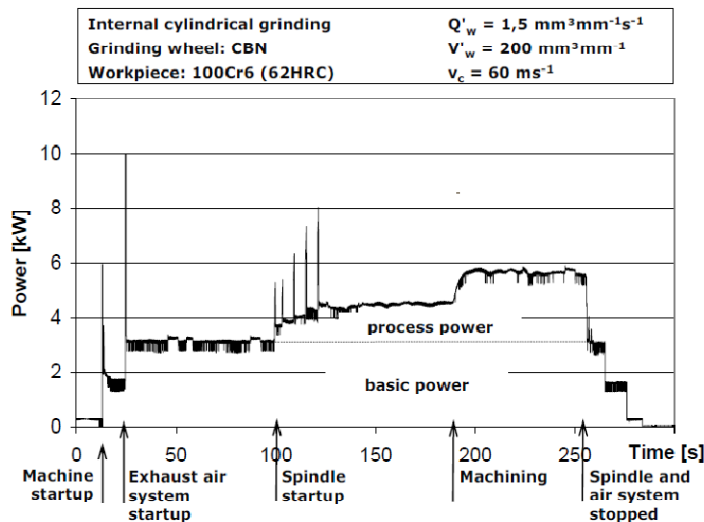

Figure 4.10: Electrical energy consumption of a grinding process (Herrmann *et al.*, 2008)

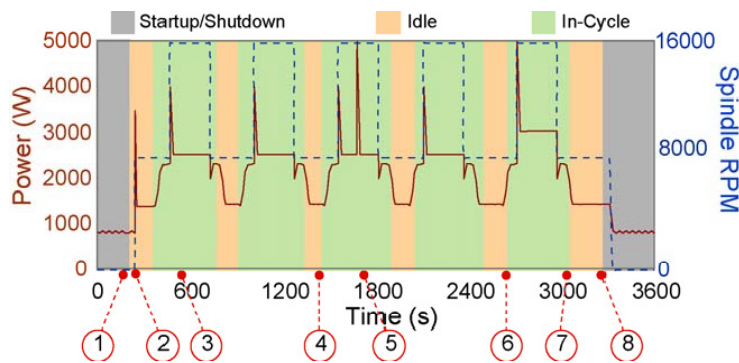

Figure 4.11: Energy load profile of the machining process over time with the respective events detailed in Table 4.6

Event	Time	Reasoning
1. Machine idle	242 s	Average energy use < idle threshold; spindle speed = 0
2. Expected energy spike	243 s	Spike due to spindle startup (0–8000 rpm)
3. Expected energy spike	464 s	Spike due to spindle speed increase (8000–16,000 rpm)
4. Idle energy constant	1457 s	Previous two idle periods energy use constant at 124 kJ
5. Anomalous spike	1679 s	Energy spike unaccompanied by shift in spindle RPM. Potential failure in spindle
6. Idle energy increase	2612 s	Current idle period energy use (211 kJ) > past idle period average energy use (124 kJ)
7. Part energy higher	3074 s	Current part energy (1218 kJ) > previous parts average energy (1087 kJ)
8. Idle energy trend	3309 s	Idle energy increasing monotonically over past two periods (342 kJ > 211 kJ > 124 kJ)

Table 4.6: Energy consumption and spindle rpm profile for case study with results of the event reasoning (Vijayaraghavan and Dornfeld, 2010)

Similar studies were also done by Avram and Xirouchakis (2011) who used cutter location data and speed values as well as specific characteristics of the spindle and feed axes and cutting force model to establish the energy required by a machine tool system. They claim that their method is able to provide more accurate energy estimation for specific milling operations than LCA tools which generally rely on a specific energy rate for each process and material.

Energy is often wasted because of unnecessary machine operation, even when an energy efficient machine is used. According to Hesselbach *et al.* (2008), energy peaks induce extra energy costs and should therefore be minimised or at least harmonised by considering process chains of several machine tools. Diaz *et al.* (2009) showed that Kinetic Energy Recovery Systems (KERS) can reduce average power consumption by up to 25% (depending on workpiece geometry and machining time) by recovering energy from the spindle motor. Park *et al.* (2009) have proposed several technologies to reduce power consumption for grinding as shown in Table 4.7.

Power Saving Parameters	Detailed Technologies
Grinding Power	Feeding power reduction <ul style="list-style-type: none"> - Weight reduction of grinding wheel carriage; optimal design by CAE analysis, application of honeycomb structures, and lightweight materials - Driving mechanism design for minimisation of friction energy; application of direct driving, built-in driving, linear driving mechanism Spindle shaft power reduction during grinding
Pure grinding time	Pure grinding time reduction by applying ultra-high speed grinding technologies <ul style="list-style-type: none"> - Increase of maximum power with a decrease of total power because of pure grinding time reduction Cost reduction of disposal power using CBM wheel grinding (in conventional grinding, the disposal power increases as the abrasives, mixed with coolant, flow into the machining surface)
Fixed power	Power reduction of lubrication, coolant, and air supply during one cycle Fixed power reduction for maintaining actuator condition <ul style="list-style-type: none"> - Change of ordinary operating system (it always needs energy) with an optimal energy supplying system; intermittent or high-efficiency operation by applying an inverter motor and accumulator (it is known that up to 40% of energy savings can be made by optimising the coolant system)
Idling time	Power-saving by a reduction of work set up time High speed of loading/unloading system, and several actuators Information-processing time reduction between CNC and PC

Table 4.7: Power-Saving Technologies in Grinding Machine (Park *et al.*, 2009)

4.4.5 Energy Research on the Tool-chip level (Theoretical Process Energy)

The last and most focused manufacturing system level is the tool-chip level which represents the actual material transformation process. This involves mechanical and chemical knowledge of the process in order to establish the theoretical energy consumption values of the process. On this level, research has been conducted to examine the energy consumption at the tool-chip interface of various processes.

Draganescu *et al.* (2003) conducted experiments to model machine tool efficiency so that the SEC could be determined for establishing cutting parameters and the consumed energy necessary for removing a certain quantity of chips; amongst a range of parameters such as depth of cut, tool speed etc. they found that the feed rates have the greatest influence on energy consumption. As derivation of SEC is dependant on a multitude of parameters there can sometimes be complexities in establishing the SEC from experimental observations as evident in Equation 4.2.

As denoted by Draganescu *et al.* (2003) the specific energy of cutting, E_{cs} :

$$E_{cs} = \frac{\pi D F_t}{3.672 \times 10^6 s_z t B z \eta} \quad \text{[Equation 4.2]}$$

Where,

D is the diameter of the mill (mm),

s_z the feed per tooth (mm/tooth),

t the depth of milling (mm),

B the contact length of the milling tool (mm),

z the number of teeth of the milling tool,

$F_t = f(v, s_z, t, B; z; A)$ the tangential component of cutting force (N), as a second order polynomial function, with natural logarithms of the above parameters, including the cutting speed, v (m/min), and the non-symmetry of milling, A (mm), obtained also by statistic modelling, and

$\eta = f(v, D, F_t)$, the milling machine efficiency.

The large number of variables required to establish the energy for cutting may be infeasible in an industrial application. A more generic method of establishing the SEC for cutting has been proposed by Kalpakjian and Schmid (2008) and is given in Equation 4.3:

$$u_t = \frac{F_c V}{w t_o V} = \frac{F_c}{w t_o} \quad \text{[Equation 4.3]}$$

Where,

u_t is specific energy for cutting.

F_c is the cutting force

w is the width of the cut

t_o is the undeformed chip thickness

For a simple way of establishing the SEC for cutting, tables of various energy values based on the different parameters can be used. Kalla *et al.* (2009) have put together a table of the average specific cutting energy based on material type, the respective feeds and speeds and density as shown in Table 4.8.

Specific energy for other processes can also be established through correlating processing parameters. Ghosh *et al.* (2008) has modelled the specific energy requirement of deep grinding and established that the total energy for grinding can be summed up using Equation 4.4:

$$U_{total}=0.5\{(U_{pl}+U_c)+U_{pri_r}+U_{sec_r}\} \text{ [Equation 4.4]}$$

Where,

U_{total} is the total energy for grinding

U_{pl} is the specific energies of ploughing

U_c is the specific energy for chip formation

U_{pri_r} is the specific energy for primary rubbing

U_{sec_r} is the specific energy for secondary rubbing

Further studies on machining can be found in Munoz and Sheng's (1995) work who looked at the environmental impact of machining processes. One of the quantifiable dimensions in their analysis included energy utilisation and process rate. Other studies of theoretical energy consumption of various manufacturing process can be found in Kalpakjian and Schmid (2008) who give detailed explanations and descriptions of the energy required for cutting, forming and deformation.

Sarwar *et al.* (2009) have done a detailed analysis on the specific cutting energy for bandsawing different work piece materials. Rajemi *et al.* (2010) have looked at the minimal energy required for turning and the optimal conditions for machining a product. Kuzman and Peklenik (1990) have done an energy evaluation of the cold forming process. Other studies on other processes as cited by Gutowski *et al.* (2009) include grinding (Baniszewski, 2005; Ghosh *et al.*, 2008), Laser Direct Metal Deposition (Morrow *et al.* 2004), Electric Induction Melting (Jones, 2007), injection moulding (Mattis *et al.* 1996; Thiriez and Gutowski, 2006). Gutowski *et al.* (2009) analysed the energy demand of 36 processes out of 10 manufacturing technologies and showed that recent high technology processes like thermal oxidation and electrical discharge machining (EDM) drilling require larger specific electrical energy requirements than more traditional manufacturing processes, see Figure 4.12.

Material	Hardness [Brinell hardness number]	Specific cutting energy, U_p [W/ mm ³ per sec] (Hp/ in ³ per min)	Cutting Speed, V (m/min, ft/min)	Feed per tooth, f_t (mm/tooth, inch/tooth)	Density (kg/m ³)
Aluminum Alloys	30 - 150	0.98 (0.36)	120 - 140, 400 - 450	0.28 - 0.56, 0.011 - 0.022	2712
Magnesium Alloys	40 - 90	0.49 (0.18)	180- 250, 600 - 800	0.2 - 0.5, 0.008 - 0.02	1770
Tungsten	200	6.24(2.3)	10 - 25, 30-70	0.025 - 0.08, 0.001-0.003	19600
Copper	80	2.98 (1.1)	30 - 45, 100 - 150	0.15 - 0.30, 0.006 - 0.012	8930
Titanium	80-100	3.26 (1.2)	25 - 30, 80 - 100	0.1 - 0.2, 0.004 - 0.008	4500
Brass	150 - 200	2.25 (0.83)	60 - 90, 200 - 300	0.18 - 0.36, 0.007 - 0.014	7700-8700
Bronze	-	1.36 (0.50)	45 - 55, 150-180	0.05 - 0.25, 0.002 - 0.010	8900
Malleable iron	-	1.55 (0.57)	33 - 40, 110-130	0.15 - 0.30, 0.006-0.012	6800-7800
Stainless steel	100	1.36 (0.5)	30 - 37, 100-120	0.08 - 0.15, 0.003-0.006	7480-8000
Steel, Low carbon	175-225	1.63 (0.60)	90 - 185, 300-600	0.01 - 0.18, 0.0005-0.007	7480-8000
Steel, Medium carbon	225-275	1.95 (0.72)	45 - 140, 150-450	0.01 - 0.13, 0.0004-0.005	7480-8000
Steel, Hardened	275-325	2.39 (0.88)	15 - 70, 50-225	0.005 - 0.08, 0.0002-0.003	7480-8000
Cast iron, soft	150-180	0.81 (0.30)	25 - 33, 80-110	0.2 - 0.4, 0.008-0.016	6800-7800
Cast iron, medium	180-220	1.7 (0.63)	18 - 45, 60-150	0.2 - 0.33, 0.007-0.013	6800-7800
Cast iron, hard	220-300	2.5 (0.92)	25 - 28, 80-90	0.15 - 0.30, 0.006-0.011	6800-7800
Gray cast iron	220-260	1.52 (0.55)	15 - 26, 50-85	0.25 - 0.46, 0.010-0.018	6800-7800
Unalloyed steel	110	1.36 (0.5)	48 - 68, 160-220	0.1 - 0.35, 0.004-0.012	7850
Unalloyed steel	150	2.2 (0.81)	36 - 45, 120-150	0.05 - 0.25, 0.002 - 0.01	7850
Unalloyed steel	310	2.93 (1.08)	27 - 40, 90-130	0.025 - 0.2, 0.001 - 0.008	7850
Low alloy steel	125-225	2.52 (0.93)	27 - 38, 90-125	0.05 - 0.13, 0.002 - 0.005	7850
Low alloy steel	225-425	3.31 (1.22)	25 - 33, 70-110	0.025 - 0.1, 0.001 - 0.004	7850
High alloy steel	150-300	2.96 (1.09)	15 - 27, 50-75	0.01 - 0.2, 0.0005 - 0.008	7850
High alloy steel	300-450	4.59 (1.69)	9 - 18, 30-60	0.005 - 0.07, 0.0002-0.003	7850
Nodular cast iron	160	1.21 (0.45)	33 - 43, 110-140	0.28 - 0.56, 0.011 - 0.022	6800-7800

Table 4.8: Average values of energy per unit material removal rate and recommended speeds and feeds (Kalla *et al.*, 2009).

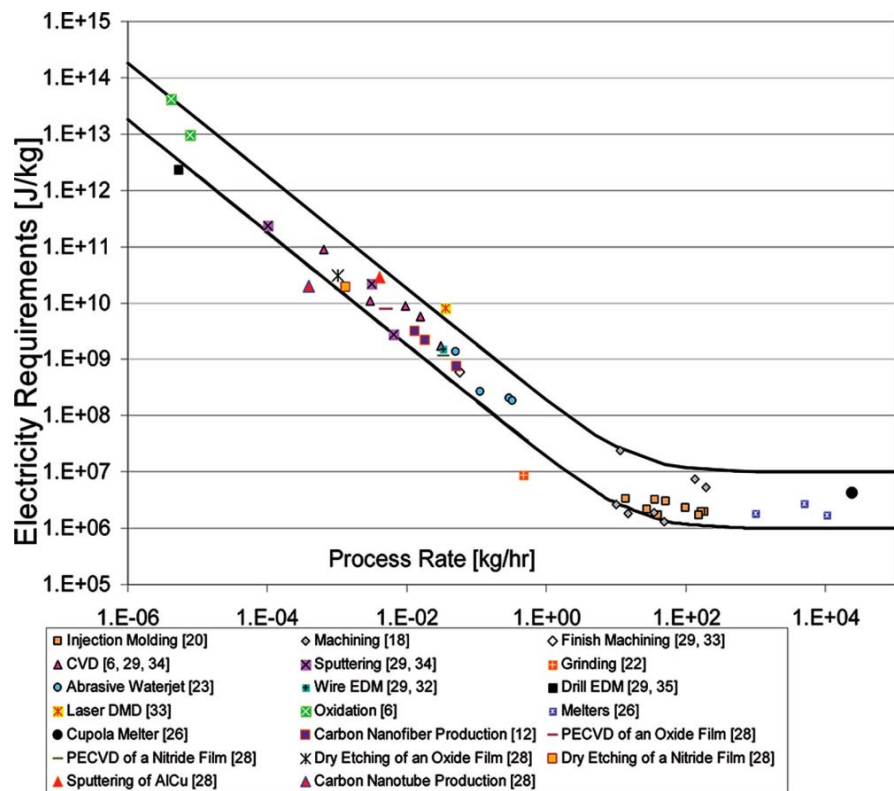

Figure 4.12: Work in form of electricity used per unit of material processed for various manufacturing processes as a function of the rate of material processing (Gutowski *et al.*, 2009)

4.5 Management of Energy Data

One of the main challenges with modelling energy consumption within a manufacturing system is monitoring and managing energy data. In recent years Muller and Loffler (2010), Chiotellis *et al.* (2010), Herrmann *et al.* (2010) all noted an evident lack of monitoring of energy flows within a factory. In particular Muller and Loffler (2010) believe that the availability of energy related data in industry during the planning process is still very rare. In addition to the lack of monitoring systems, the amount of information required can be very complex and requires a robust framework to deal with information on all levels. As a result they have all proposed various information formats to aggregate energy values for decision making within production.

Muller and Loffler (2010) believe that detailed analysis of energy consumption can help with decision making and planning. Current energy systems in industry only provide highly aggregated data such as per factory or per building, very rarely per production line. As such they have suggested using energy profiles to indicate the relevant modes of operation as seen in Figure 4.13: Switch on (I), normal operation (II), switch to standby (III), standby (IV), and switch off (VI). Energy consumption projections can then be made from the data collected. They believe that although these analyses are uncommon in industry today, they need to be established in order to meet future requirements (e.g. energy management systems according to EN 16001 (British Standards Institution, 2009)). Figure 4.14 also shows how energy data be used in the planning process. Chiotellis *et al.* (2010) also propose having a data base of energy profiles for production machines which can be used to create energy labels for production equipment.

Like Muller and Loffler (2010), Herrmann *et al.* (2010) also believe that the effective metering of energy flows provides detailed information that improves the management of the manufacturing system and provides the foundation for energy efficient planning. They have applied smart metering for industrial purposes like production planning.

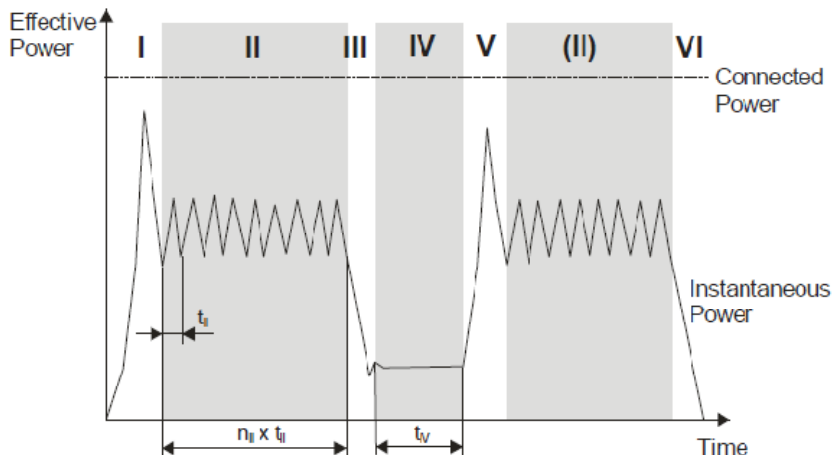

Figure 4.13: Load profile during a representative period of operation (Muller and Loffler, 2010)

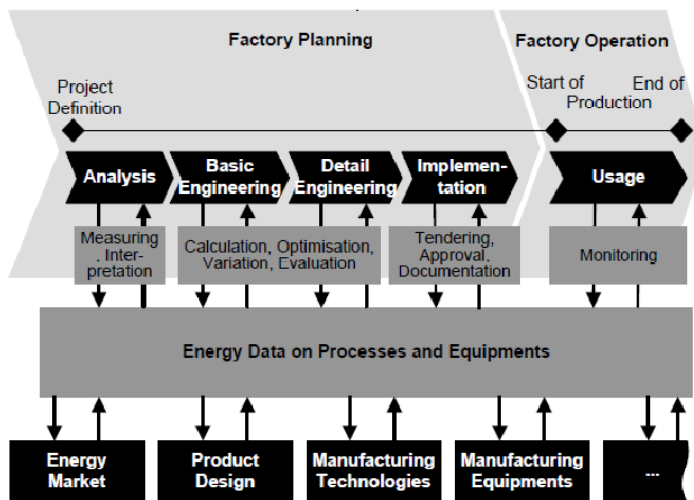

Figure 4.14: Energy related activities within the planning process and management of energy related data (Muller and Loffler, 2010)

First applied in private households, smart metering substituted analogue metering and reading of the consumed electrical work by computerising the process, tracking not only the electrical work but also the characteristics of specific power consumption. Industrial smart metering comprises of sensors, processors and analysers to capture, transfer and resolve energy and resource flows in manufacturing systems. They also have assigned energy and resource flows to hierarchical levels starting top-down from factory, to machine tool level and have enabled the production of guidelines for energy metering requirements on each of those levels. As data volumes will increase exponentially lower down the levels it is important to set the correct resolution and address them through appropriate hardware and software systems, see Figure 4.15.

Vijayaraghavan and Dornfeld (2010) also noted the need for various energy analyses at various levels as shown in Figure 4.16. They recommend that for the analysis of complex manufacturing processes and systems, software tools would need to have the following capabilities:

- Concurrent monitoring of energy use with process data
- Standardised data sources
- Scalable architecture for large data volumes
- Modular architecture to support analysis across different manufacturing scales.

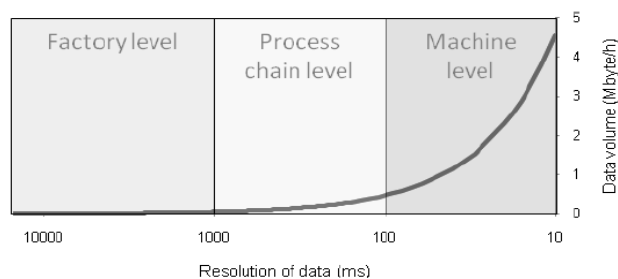

Figure 4.15: Resulting data volume from 64-bit measurement values depending on its temporal resolution (ranging from 1.5 min up to 10 ms) from a single data output. (Hermann *et al.*, 2010)

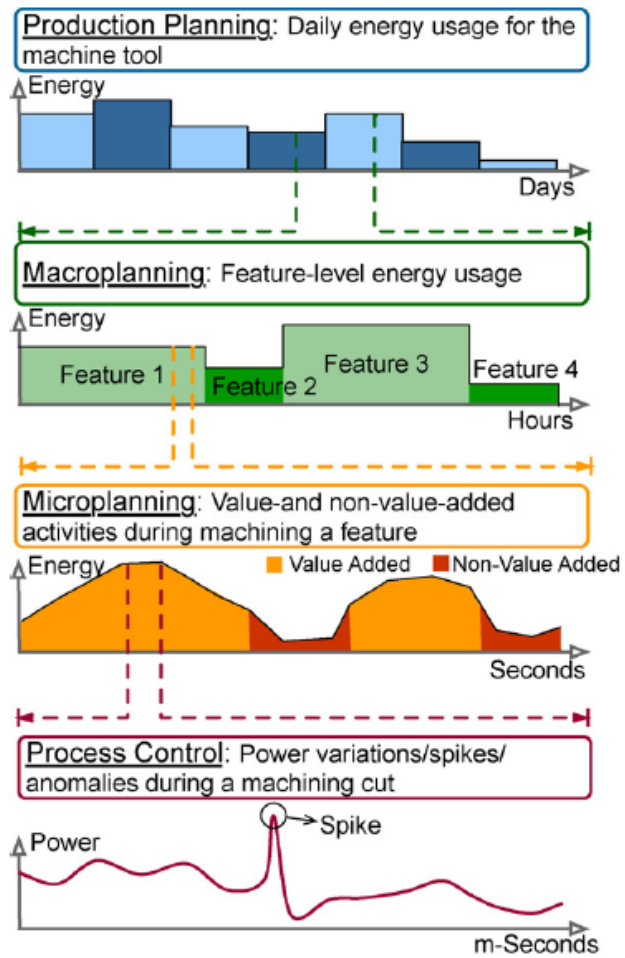

Figure 4.16: Examples of analysis across various levels. (Vijayaraghavan and Dornfeld, 2010)

Based on these requirements, Vijayaraghavan and Dornfeld (2010) have developed an automated energy monitoring system using two key components: an interoperability standard for manufacturing data that can normalise data exchange in the manufacturing system, and a rules engine and complex event processing system to handle data reasoning and information processing.

In their system they used MTConnect, a data exchange standard based on XML, to achieve standardization of data in machine tools during data collection. It is an XML-based standard and describes the structure of manufacturing equipment along with the near real-time data occurring in the equipment. It allows a way for logically organizing data from equipment without being constrained by physical data interfaces. With MTConnect, the operational data of the machine tool can be monitored in context with the energy consumption data. Diaz *et al.* (2009) also proposes using MTConnect to improve the energy performance of a machining centre as shown in Figure 4.17.

To gather the information into a centralised area, several researchers have been working to produce a database of energy information. Overcash *et al.*(2009) at the University of Wichtita are working with various researchers to produce a Life Cycle Inventory of processes based on engineering rule-of-practice analysis by quantifying input material, energy requirements, material losses and machine variables.

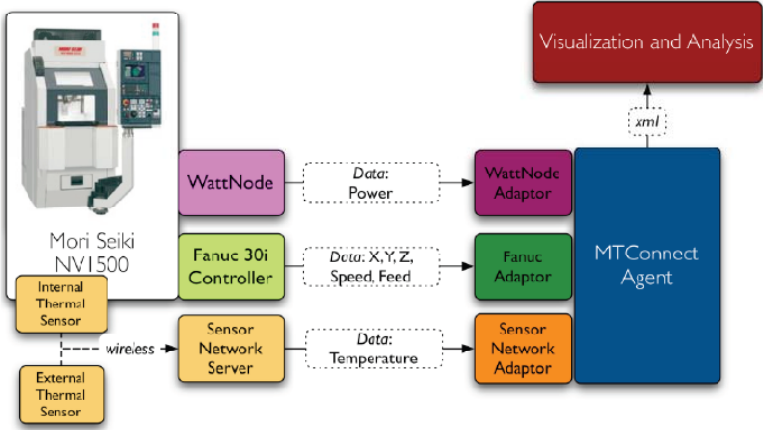

Figure 4.17: Unified monitoring scheme using MTConnect (Diaz *et al.*, 2009)

This database known as Unit Process Life Cycle Inventory, UPLCI (2010) will involve 50-70 unit processes and will consist of energy and mass profiles for each unit process life cycle which follows the German DIN8580 standard on manufacturing processes terms and definitions as the basis for its taxonomy with 6 main process groups – Original forming, Transforming, Separating, Joining, Coating and Finishing and Change of material properties (as shown in Figure 4.21). The database, when complete, will provide a comprehensive source of energy information on a range of commonly used manufacturing processes. The benefit of using the UPLCI database is that the energy values can be adjusted for each case to include major variables affecting the process operation.

Another similar initiative is the ‘Cooperative Effort on Modelling Process Emissions in Manufacturing’, CO₂PE which is led by Duflou (2009) at the University of Leuven to cluster forces in different continents, involving machine builders as well as academics, to analyse existing and emerging manufacturing processes for their ecological impact in terms of direct and indirect emissions.

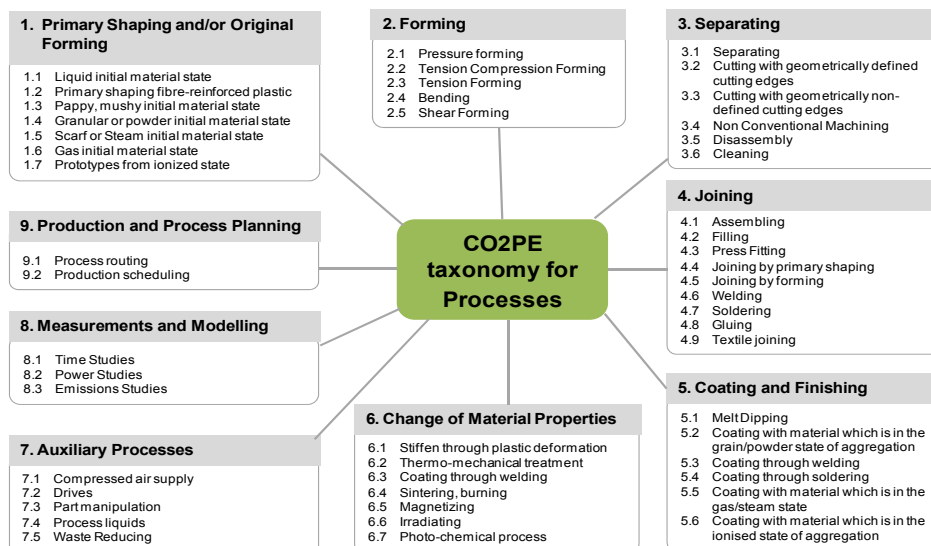

Figure 4.18: Taxonomy of Processes used by CO₂PE (UPLCI, 2010)

Substantial research has been targeted to document, analyse and reduce process emissions for a wide range of available and emerging manufacturing processes (Chiotellis *et al.*, 2010; Pusavec *et al.*, 2010; Devoldere *et al.*, 2007; Herrmann *et al.*, 2007, Gutowski *et al.*, 2007). Duflo will employ a centralised overview and coordinating effort which will avoid redundancy in data collection efforts while facilitating direct communication between parties with overlapping interests and expertise needs. The effort will be based on the matrix as seen in Figure 4.19.

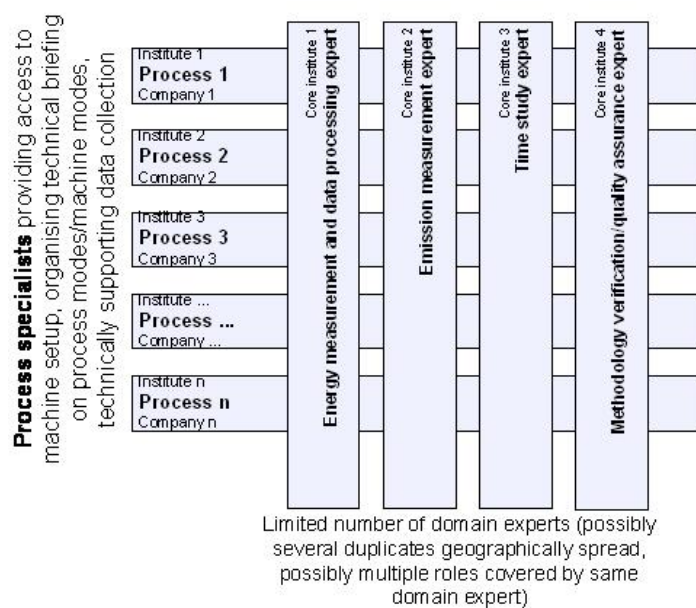

Figure 4.19: Operational cooperative scheme for data collection and analysis (Duflo, 2009)

4.6 Chapter Summary

This chapter has provided an overview of the research that has been done on the product level and on a manufacturing systems level. LCA is the principal methodology used to analyse the energy flows over a product's life cycle. Different variations of the methodology has been created to either limit the analysis to a specific impact or to focus the scope of the study to a particular life cycle phase. LCA often use datasets that are based on distinct values for different materials and processes where the energy use of a process is typically given as a function of mass. This is typically a source of significant

error within complex design geometry with very lengthy and difficult processes and operations. As such the literature review has highlighted a research gap and has indicated a need for a greater understanding of the impact of processing time and geometry on the energy consumption from the manufacture of a product.

The research on a manufacturing systems level has shown that the energy consumption of a process is not a constant rate but highly influenced by a wide range of issues. On the enterprise level, much of the considerations are based on logistics and the supply chain which are both very application dependant hence it has been excluded from the scope of this research. The energy considerations discussed in this thesis will focus on the facility level to the tool-chip level especially since the literature review has indicated that processing parameters and operational procedures both have a significant effect on the energy use of production equipment. A more accurate and straight forward energy estimation of manufacturing activities is required to provide greater transparency of the energy use within production so that more effective energy saving strategies can be implemented. The need for improved management and monitoring of energy consumption within a manufacturing facility has led to a proliferation of energy management software tools which will be discussed in the next chapter.

Chapter 5 Review of Commercially Available Software for Energy Management and Analysis within Manufacturing Systems

5.1 Introduction

This chapter reviews the common commercial tools and software currently available for assessing, monitoring and managing energy consumption in the manufacturing industry. The initial part of this chapter looks at methods to assess energy consumption across a product life cycle while the latter sections look at methods that focus on energy use within a manufacturing facility.

5.2 Overview of Commercial Software

Energy software tools can be categorised into two main approaches:

- 1) Product life cycle based,
- 2) Energy management based,

The analysis of energy embodied within a product is typically established through the use of LCA based software which uses generic process data from a pre-existing life cycle inventory database. Currently most LCA software is unable to attribute energy consumption and model energy flows from overhead processes such as heating and lighting within a production facility to a product. To monitor and analyse the energy consumption within a building or a facility, the second group of software systems (energy management) is used. This allows the energy consumption within a specific manufacturing facility to be tracked and monitored and the software enables detailed analysis of the energy consumption. Both categories of software will be further evaluated and described in the following sections.

5.3 Product life cycle based software

As discussed in Chapter 4, Life Cycle Assessment is commonly used to assess the environmental impact of products. Since these assessments often require the processing of large amounts of data, software tools have been developed to manage the data and facilitate the calculations. The LCA approach is the de facto standard used by most software for the environmental assessment of a product. In this section only the commonly used LCA software that are able to determine the energy consumed over the life cycle of a product will be reviewed, for an extensive survey of generic LCA software, refer to Jönbrink *et al.* (2000). The commonly used commercial LCA software includes SimaPro7.0, GaBi 4.0, Team 4.0, Umberto 6.1 as well as CES Ecoselector (Machado and Cavenaghi, 2009).

Ten commonly used software packages were evaluated based on the energy modelling requirements identified from the research work in this thesis to determine if there was a software package that would be suitable for modelling the embodied product energy of a product during the production phase.

The software were evaluated based on the following aspects –

- The modelling of energy flows within production
Is the software able to model the use of energy within a manufacturing facility and attribute the energy to the production of a unit product?
- The consideration of facility energy consumption
Does the software allow for the consideration of facility energy consumption (e.g. heating, lighting, ventilation)?
- Decision support
Are there any decision support tools within the software to enable the user to provide directions for energy improvements?
- Energy efficiency considerations
Does the software provide energy efficiency evaluations or benchmarking of the product being assessed?

All the LCA tools reviewed were able to establish the embodied energy of a product using data from inbuilt databases or external databases like Eco Invent. As long as the processes required were known and the parameters could be defined, the software are able to calculate the energy that was required to produce the product. Comprehensive LCA packages such as SimaPro 6.0 (Pre Consultants, 2011), GaBi 4.0 (PE International GmbH, 2007) and TEAM 4.0 (Ecoliban Group, 2011) are able to model energy embodied within a product across different life cycle phases but the final embodied energy is attributed within the overall environmental impact of the product and hence a singular embodied energy value cannot be established.

Other LCA software that calculates the embodied energy of product is the Cambridge Engineering Selector, CES, Eco Audit Tool (Granta Design Ltd, 2011), CarbonScope (CleanMetrics™, 2011) and EcoFly 3.0 (PlesTech, 2010). Unlike the other LCA software which requires time consuming data input, these can provide a quick estimation of the energy usage and CO₂ footprint of a product design by calculating the energy embodied by each manufacturing process by attributing a generic energy consumption rate per mass of material processed for a specific process. Eco Fly has the additional advantage of having a 'Concept Review' module that manages the concept selection process. A range of efficiency targets can also be set which can be used to evaluate different product design concepts.

WattzOn (Synthesis Studios, 2009) is a web based tool that enables users to calculate the energy consumption of a person's lifestyle and also contains a database of the average embodied energy of typical products. The database has 21 categories of different products from appliances to pet products and the embodied energy of a range of products has been calculated over their life cycle. For example a 340g electric kettle with a lifespan of 5 years has an embodied energy of approximately 95.7 MJ.

In addition, most LCA software is unable to model the specific energy flows within a production system. Of the software reviewed only Umberto® (developed by the Institute for Environmental Informatics, Hamburg GmbH) is able to conduct energy and material flow analysis through graphical modelling and visualisation within the program (ifu, 2011). The energy flows modelled were static and thus unable to model changing production rates and variations in processing parameters.

Only two LCA software – Athena[®] Environmental Impact Estimator developed by Athena[®] Sustainable Materials Institute (2011) and Building for Environmental and Economic Sustainability Software, BEES developed by the National Institute of Standards and Technology (NIST, 2011) consider energy consumed within a facility and are able to assess the energy requirements of building services such as heating, lighting and ventilation and attribute this energy to an entity. Both Athena[®] Environmental Impact Estimator and BEES can provide decision support by combining the environmental and economic performance (costs of initial investment, replacement, operation, maintenance and repair and disposal) into an overall performance measure using a multi attribute decision analysis. However both software are for assessing buildings and are not applicable to the assessment of general products.

Of the software reviewed, only 1 was able to model energy flows within a production system, 2 considered the energy consumption within facilities, 3 provided decision support for energy improvements and 1 provided energy efficiency considerations. An overview of the review is shown in Table 5.1.

There is a distinct lack of LCA tools that are able to model the energy consumption within a production system and that can account for both process energy and the energy required by the building services. All the LCA software use generic data when calculating the energy required by manufacturing process which is based on a per unit mass basis with limited flexibility for the addition of customised energy data from a specific production plant. Most of the LCA software provides a detailed breakdown of the environmental impact of the product over the life cycle which only highlights the life cycle phase that is most energy intensive, but provided little or almost no detailed breakdown on the energy embodied by the product. Consequently there is a lack of information that can be used to support decision making within design or production. Energy efficiency considerations are also not included in many of the software.

The next section will review the software tools that can monitor and track energy flows within a production facility.

Name of Software	Developer	Availability		Availability	Applicability	Calculation of embodied energy	Modelling of energy flows within Production	Consideration of facility energy consumption	Decision Support for energy efficient improvements	Energy efficiency considerations
		Desktop	Web-based							
SimaPro 6.0	Pre Consultants	✓		Licensed	Products	✓				
GaBi 4.0	PE international	✓		Licensed	Products	✓				
TEAM 4.0	Ecoliban Group	✓		Licensed	Products	✓				
CES Eco Audit Tool	Granta Design	✓		Licensed	Products	✓				
EcoFly 3.0	PlesTech	✓		Licensed	Products	✓			✓	✓
CarbonScope™	CleanMetrics		✓	Licensed	Products	✓				
WattzOn	Synthesis Studios		✓	Freeware	Products	✓				
Umberto 5.0	Institute for Environmental Informatics	✓		Licensed	Products	✓	✓			
Athena® Environmental impact estimator 4.1	Athena Sustainable Materials Institute	✓		Beta version is free	Buildings	✓		✓	✓	
Building for Environmental and Economic Sustainability, BEES	National Institute of standards and Technology		✓	Freeware	Buildings	✓		✓	✓	

Table 5.1: Evaluation of LCA based software that consists of energy modelling features

5.4 Energy Management Systems

Energy management systems, EMS, are typically used to help companies control their energy use by systematically tracking and planning energy use in equipment, processes, buildings, industrial facilities and entire corporations. The European standard for energy management systems is EN 16001 (British Standards Institution, 2009) which requires organisations to measure and assess actual energy use and record significant changes through tracking past, present and unexpected energy consumption.

The most basic form of energy management tools are in the form of a spreadsheet where utility bills are entered and an analysis is carried out with the collected data. An example of an Excel based tool is the Energy Lens by BizEE (2011). The Quick Energy Profiler, Quick PEP, by the U.S Department of Energy Industrial Technologies Program, DOE- ITP, (U.S DOE, 2011a) is another simple tool that helps users to establish a baseline for the energy consumed within a plant or facility.

For large amounts of data, a database management system is required. Using modern computer based monitoring and control systems, which are designed to operate on a plant wide basis, can yield further major improvements in energy efficiency. This can be integrated within a thorough energy management program which usually consists of metering and monitoring of energy consumption, identifying and implementing energy saving measures, and verifying savings with proper measurements. These software systems such as Optima (Optima Energy Management) bring together groups of readings, calculating totals and averages, and indicating trends and optimum operating conditions within a single platform. Other systems like T&D Solution (Itron, 2011), AVReporter (KONsys, 2011), xChangePoint (EPS Corp, 2011) and eSight (eSight Energy Group, 2011) can be based on real time information obtained remotely through special energy meters that transmit energy consumption data to a server.

Fully comprehensive software solutions like Energy Management Application Platform (EnerNOC, 2011), Hara Environmental and Energy Management (Hara, 2011) and EnergyCAP (EnergyCAP Inc., 2011) include more sophisticated features such as planning and scheduling tools to optimize energy use and supply, energy balance management tools to support the real time monitoring and control of peak energy

demand, and in-depth evaluation tools that correlate external variables such as weather, production and building occupancy on energy usage.

Other energy tools have also been developed for the modelling and analysis of energy consumption of a building. Energy Plus (DOE Building Technologies Program) is the primary software tool used for energy performance analysis of commercial buildings and enables multi-zone air flows and heat balances to be modelled (U.S DOE 2011b). The Opt E-plus and SUNREL (both by National Renewable Energy Laboratory) enable the optimization of building design by simulating various designs and technology options against energy performance (NREL, 2011). The tool facilitates many simultaneous calculations and thus can manage thousands of simulations incorporating dynamic interactions between the building envelope, the external environmental and its occupants.

The DOE-2 is a portable program that is compatible with most computer systems and provides designers and researchers with a quick energy analysis of various building parameters and the impact on thermal comfort of the occupants (Hirsch, 2009). Various level details on the building design or alternative design options can be included based on the user's requirements.

Specific process support tools have been developed by the U.S DOE-ITP to aid with identifying and analysing energy system savings opportunities within a plant or facility (US DOE, 2011a). The suite of tools cover a range of services typically found in production plants such as compressed air, motors, pumps, process heating and steam. For example the MotorMaster+ and AIRMaster+ uses plant specific data and evaluates the energy consumption of motor and compressed air systems based on various equipment configuration system profiles. They also provide estimates of energy savings that can be made from a range of energy efficiency measures. In addition MotorMaster+ provides purchasing decision support and analysis through the evaluation of the cost effectiveness of repairing or replacing motors. The other tools that provide efficiency assessments are the Fan System Assessment Tool, the Pumping System Assessment Tool, Process Heating Assessment and Survey Tool and Steam System Tool Suite .

System Level	Name of Software	Developer	Approach				Data Requirement		Complexity		Availability		Type of Analysis				
			Accounting	Monitoring	Management	Benchmarking	Utility data	Facility and Production data	Excel Tool	Full software Suite	Desktop	Web-based	Carbon accounting	Energy pricing and demand management	Operational improvements	Efficiency improvements	
Overall System	Energy Lens	BizEE	✓		✓		✓	✓	✓		✓						
	Quick Plant Energy Profiler (Quick PEP)	U.S DOE- ITP	✓			✓	✓		✓		✓		✓				
	Optima	Optima Energy Management	✓	✓	✓		✓			✓			✓				
	T+D Solution	Itron	✓	✓	✓			✓			✓		✓				
	AVReporter	KONsys	✓	✓	✓		✓	✓		✓	✓		✓				
	xChangepoint	EPS Corp	✓	✓	✓			✓	✓	✓	✓	✓	✓	✓	✓		
	eSight	Esight Energy Group	✓	✓	✓	✓	✓	✓		✓	✓	✓	✓	✓	✓	✓	
	Energy Management Application Platform	EnerNOC	✓	✓	✓	✓	✓	✓		✓	✓	✓	✓	✓	✓	✓	✓
	Hara Environmental and Energy Management	Hara	✓	✓	✓	✓	✓	✓		✓	✓	✓	✓	✓	✓	✓	✓
EnergyCAP	EnergyCAP Inc.	✓	✓	✓	✓	✓	✓		✓	✓	✓	✓	✓	✓	✓	✓	
Building	Energy Plus	U.S DOE- BTP	✓			✓	✓		✓		✓					✓	
	Opt E-plus	National Renewable Energy Laboratory, NREL	✓				✓		✓		✓					✓	
	SUNREL		✓				✓		✓		✓					✓	
	DOE-2	Lawrence Berkeley National Laboratory	✓			✓	✓		✓		✓					✓	
Compressed Air	AIRMaster+	U.S DOE- ITP	✓	✓	✓			✓		✓		✓			✓	✓	
Fan	Fan System Assessment Tool (FSAT)		✓	✓	✓			✓		✓		✓			✓	✓	
Motors	MotorMaster+International		✓	✓	✓			✓		✓		✓			✓	✓	
Process	Process Heating and Survey Assessment Tool (PHSAT)		✓	✓	✓			✓		✓		✓			✓	✓	
Pumps	Pumping System Assessment Tool (PSAT)		✓	✓	✓			✓		✓		✓			✓	✓	
Steam	Steam System Tool Suite (SSST)		✓	✓	✓			✓		✓		✓			✓	✓	

Table 5.2: Evaluation of various energy management software

5.5 Chapter Summary

This chapter has provided a brief review of the commercial software that is available. Typically the evaluation of embodied energy of a product is based on a LCA approach which is supported by generic databases that provides energy consumption data on the different processes. Ten commonly used software packages were reviewed and it was found that most were not able to integrate plant specific data and also did not support the modelling of energy flows within a production system. As such, correlation of production variables and design features of a product on embodied energy were not possible.

Energy management systems on the other hand were able to model and monitor the energy flows within a production system and the software systems were able to correlate production variables to the plant energy consumption. However the energy breakdown is based on a plant perspective and could not provide a detailed breakdown of energy embodied within a product. Most of the tools provided a comprehensive set of energy analyses and evaluations based on energy information that can be entered manually or through automatic readings from meters. Some process specific tools also provided decision support based on energy and economical considerations on replacing processing equipment.

This chapter has highlighted a lack of tools that can model energy flows within a production system from a product viewpoint. The modelling of embodied energy in a product based on plant specific data will enable manufacturers to evaluate the energy efficiency of the processes used in the production of the product, thereby providing them with a starting point for the reduction of the product's environmental impact. Chapter 7 details the novel framework for modelling energy flows during the manufacture of a product which will provide the basis for modelling embodied energy during the production phase.

The next chapter will describe the research methodology applied in this research.

Chapter 6 Research Methodology

6.1 Introduction

This chapter provides an overview of the research methodology used within this thesis. The chapter begins with a brief overview of existing research methodologies before defining in detail the four defined stages of the methodology used. These stages include the initial review of literature together with the corresponding refinement in the research hypothesis, and model development for energy efficiency assessment.

6.2 A Brief Overview of Research Methodology

According to the Oxford Dictionary, research is a) “the systematic investigation into the study of materials and sources in order to establish facts and reach new conclusions”; b) “an endeavour to discover new or collate old facts etc. by the scientific study of a subject or by a course of critical investigation”. According to Creswell (2003) it is the process of making claims and then refining or abandoning some of them for other claims more strongly warranted. There are a number of different research design methods being used for management, social sciences and engineering which includes the scientific method, analytical method, empirical method, survey method, action research, case study research, quasi-experimental, etc.

Research methods are conventionally divided into quantitative, qualitative and mixed each with differing underlying approaches, tools and techniques. Quantitative methods are mainly concerned with rigorous objective measurement in order to determine the truth or falsehood of particular pre-determined hypothesis and involve the use of post positivist claims for developing knowledge, use of strategies of inquiry such as experiments and surveys, and collection of data on predetermined instruments. On the other hand, a qualitative method is largely inductive and involves the inquirer making knowledge claims which are based on primarily on constructivist perspectives and uses narrative, phenomenologies or case studies. Increasingly so, there is an emphasis on

developing an appropriate integrated mix of qualitative and quantitative research method which builds on complementarities between methods in order to build on strengths, crosscheck and triangulate the information which is most crucial for addressing the particular research questions concerned (Mayoux 2005). The mixed method involves researcher making knowledge claims on pragmatic grounds (e.g. consequence-orientated, problem-centred, and pluralistic) and employs strategies of inquiry that involve collecting data either simultaneously or sequentially to best understand the research problems (Creswell 2003). The research methodology adopted by this thesis is closely related to mixed method research. For the initial development of the framework, a qualitative method is used to establish the different energy issues and considerations from various sources of literature. For the equations associated with the framework, a quantitative method is applied through the use of a case study and is further described in the next section.

6.3 Research Methodology Adopted in this Thesis

The proposed research methodology consists of four distinct phases: research background, framework and model development, testing and validation and thesis conclusions. The methodology adopted is in line with those traditionally used within typical engineering research. Figure 6.1 provides an overview of the research approach, highlighting how various stages of the research are grouped within the four phases.

The research assertion was developed as a result of increasing legislative pressures on industry with new energy directives such as ‘Eco-Design of Energy using Products’ (The European Commission, 2005) and ‘Energy End-Use Efficiency and Energy Services’ (The European Commission, 2006) to increase their understanding of energy usage. During the establishment of the research background for the thesis, via literature survey, it became apparent that there was a need for energy rationalisation and demand control, and tools that were capable of modelling energy consumption during the manufacture of products so that energy intensive processes can be identified.

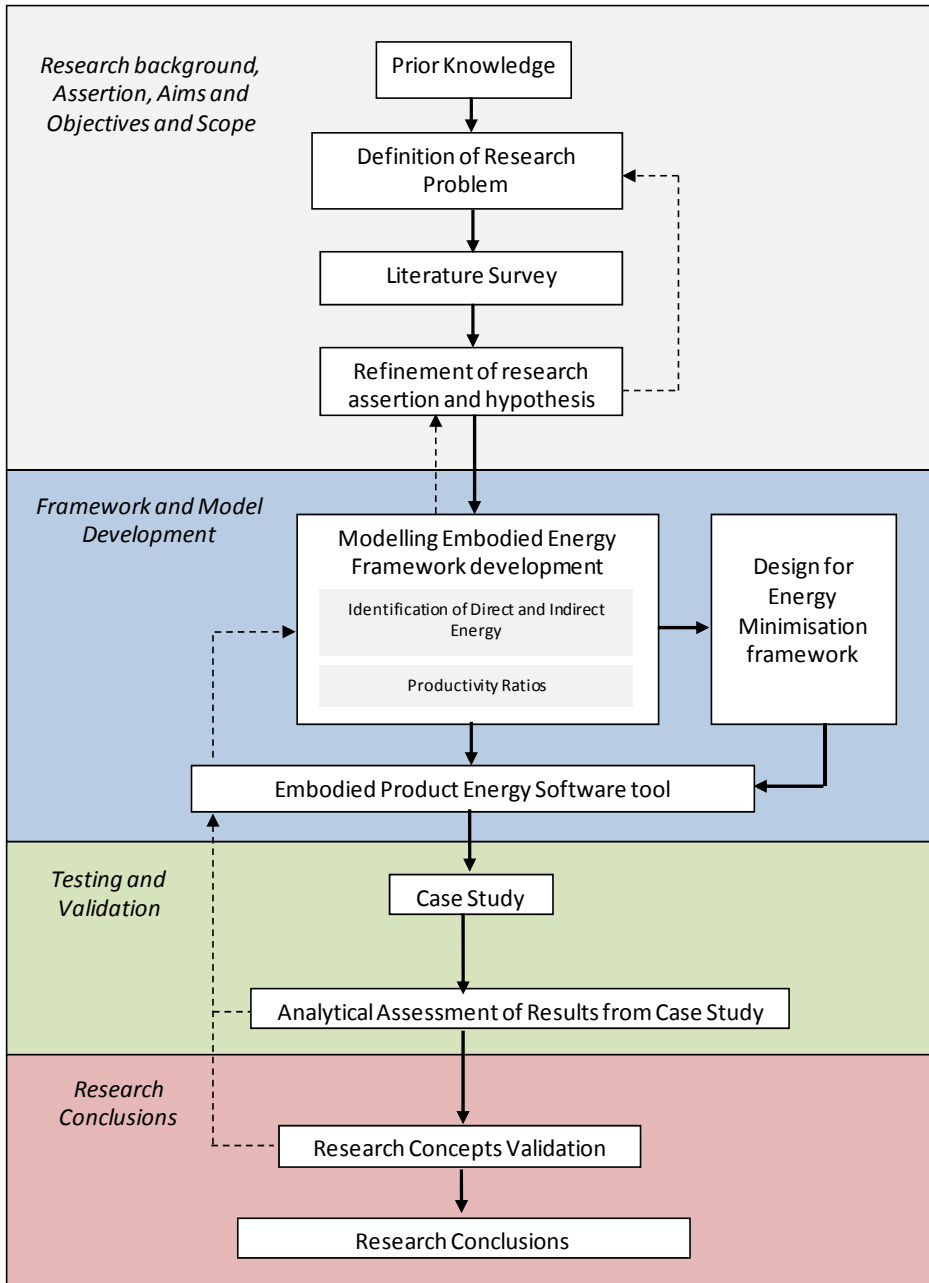

Figure 6.1: Outline of research methodology

This would facilitate decision support during the design process providing designers or engineers with process energy consumption as a performance measure. The research question was defined and its validity was confirmed through an extensive literature review and survey of relevant research.

The final establishment of the aim, objectives and scope of the research moved the work into the second phase (i.e. framework and model development). Based on the examination of energy flows through manufacturing facilities and production processes, two main categories of energy were identified – Indirect and Direct Energy. This led to the development of the framework with which energy consumption values could be attributed to a product within a manufacturing facility, so as to answer the first and second research question “Of the total energy consumed to manufacture a product, how much of the energy is used directly by the process and, how much is used by the facility that houses the process and the other supporting processes?” and “when considering the energy consumed by the facility that houses the process how can it be attributed to the manufacture of a unit product?”. The breakdown of the energy values provided the basis for the development of productivity ratios which would answer the third research question “how much of the energy consumed by the process is for productive work and how much is non-productive?” These ratios could then be used to establish a Design for Energy Minimisation (DfEM) approach to aid product designers. The DfEM methodology is expected to be an additional design tool that can support the existing ‘Design for Environment’ toolset which includes Design for End-of-Life, Design for Disassembly and Design for Recycling etc. Thus in part answering the last research question “how can design influence the energy required to manufacture a product?”. The application of the framework and methodology were brought together within a holistic software application. A suitable simulation is first identified after which a model is established through flow charts and activity diagrams to reflect the system that is being analysed. Data requirements are then identified i.e. process times, machine idle and active times, cycle times etc. This data needs to be either collected (if it exists) or generated (if it does not). Probabilistic distributions of the data also need to be identified and parameters need to be chosen. After the model has been built the simulation would need to be verified and validated with a case study.

The third phase is the use of a case study to verify and validate the model which can provide include further energy considerations and correlations with design and

Comment [Y5]: Research question

production parameters. Results from the validation can be used for further improvement to the simulation tool and the EPE framework.

The completion of the case study marks the start of the final phase of the research which is drawing research conclusions. The results from the research conducted in the third phase and the case study are used to validate the research concepts established at the start and overall research conclusions will be drawn to highlight the main research findings and contributions to knowledge.

Chapter 7 Framework for Modelling Embodied Product Energy

7.1 Introduction

This chapter introduces a framework that has been generated by this research to model the energy flows attributed to the production of a product. The model identifies various consumers of energy used throughout a manufacturing facility providing an overview of energy hotspots within the production system thereby highlighting areas for optimisation and investment to improve energy efficiency.

7.2 ‘Plant’, ‘Process’ and ‘Product’ Perspective on Energy Consumption within a Manufacturing Facility

As discussed in Chapter 4, much of the current research work on energy consumption within manufacturing has been established at different levels i.e. Enterprise, Facility, Production/Machine Cell, Machine and Tool-chip level. The research in this thesis focuses on the energy consuming activities within a manufacturing facility and thus excludes any energy consuming activities related on an Enterprise level. The energy consumed within a manufacturing facility can be broadly viewed under two different perspectives of ‘Plant’ and ‘Process’.

From a ‘Plant’ level perspective, energy is consumed by the infrastructure and other high level services that are responsible for maintaining the required production conditions/environment. Examples of ‘plant’ level consumption are lighting, heating, air-conditioning and ventilation. Some specialised manufacturing processes may require very specific environments which may be more energy intensive; an example is that of a cleanroom which requires more stringent specifications on air quality and therefore the air filtration system would be more powerful thereby consuming more energy. A subset of energy considerations on this level would include: efficiencies of the system equipment (e.g. fan and pump efficiencies), as well as the optimal set up arrangement

(e.g. luminosity per floor area or volume of air exchange per minute). In some cases, substantial amounts of energy are consumed by HVAC systems, for example painting processes where the work area needs to be maintained at a specific pressure and air quality.

At the plant level, much of the energy efficiency improvements are encompassed as part of a generic Energy Management System (EMS) which would typically involve energy audits and monitoring. The investment required to improve the energy efficiency in this level could vary significantly. This could include minor costs of replacing light bulbs with energy saving ones (which could yield limited energy saving) or significant costs of restructuring of the heating systems to parts of the factory. In any case, without any prior justification it would be infeasible for a company to continuously invest in facility improvements.

The other group of energy consuming activities occurs on a 'Process' level where energy is consumed by various production processes required to manufacture a product. This includes 'pre-production processes' such as material preparation, 'production processes' like the machining of features, and 'post-production processes' such as inspection. From this perspective, the existing research work typically has investigated areas for energy improvement which relates either to the improvement of operational procedures or machine design. The improvement in operational procedures could include minimising idle time in a process through better production planning or improving the actual transformational process through more effective process planning. Likewise the improvement in machine design could include elimination/reduction of non-essential activities (e.g. coolant, lubricant) or a more sophisticated approach to recovery of waste energy (e.g. kinetic or heat). These improvements are of particular interest to the equipment manufacturers as they maximise the efficiency of the machines. However such investigations have failed to identify the energy hotspots throughout the manufacturing system and therefore without appropriate justification, the end users of such equipment would not be able to continuously invest in replacing old machinery to improve energy efficiency.

This highlights a need for energy transparency across a production facility so that energy hotspots can be identified. The integration of energy considerations at the plant and process perspective into a 'product' perspective would give manufacturers an

effective indication of which activities and processes are energy intensive and/or energy inefficient. Hence this research uses this ‘product’ perspective to systematically identify the total energy required to manufacture a product which in this thesis is referred to as the Embodied Product Energy as shown in Figure 7.1.

Although a LCA is typically used to analyse the environmental impact and energy consumed across the entire product life cycle, there are a few concerns with utilising LCA for energy analysis. These include the data intensive and time consuming nature of LCA studies. In addition, within an LCA analysis the energy consumption are modelled based on unit mass of material processed. This focus on the use of material mass presents a number of shortcomings, which include:

1. In most cases, the complexity of features within a product rather than the absolute mass of material removed or formed determine the energy required to carry out the process.
2. Similarly, in most processes, the manufacturing parameters (e.g. feeds, speeds, oven temperature, range and rate of paint spray) significantly influences the total energy consumption.
3. Finally varying operational conditions such as idle time, number of set ups, part load etc. would impact the energy requirement within a process.

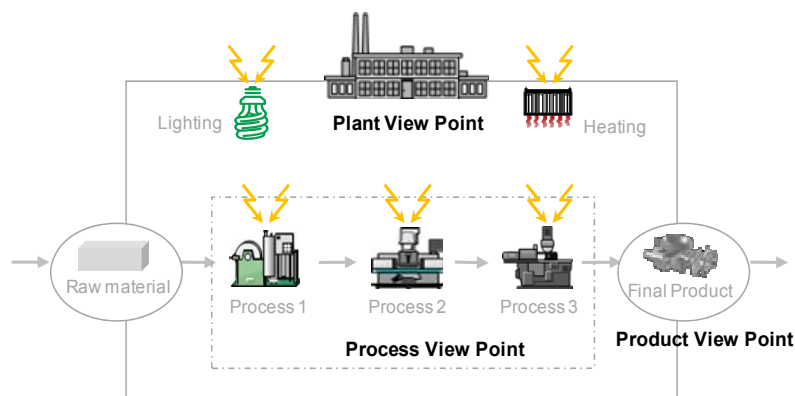

Figure 7.1: EPE represented by Plant and Process activities in a Product Viewpoint

Therefore the research in this thesis investigates a more in-depth analysis of energy requirements based on product design features, manufacturing parameters and operational procedures. Such analysis would enable engineers and designers to identify the energy hotspots during production and facilitate process design optimisation, production and process planning improvements as well as product design enhancements. In this approach the energy data from each of the three aforementioned perspectives has to be integrated within an energy model as shown in Figure 7.2.

7.3 A Framework for Modelling Energy Flows within a Production System

In order to develop a detailed breakdown of energy consumption within a production facility, there is a need to systematically model the flow of energy across various processes. This research has generated a framework, termed ‘Embodied Product Energy’, EPE, to model the energy required to manufacture a unit product. In this framework, the energy consumption is categorised into two groups: a) Direct Energy and b) Indirect Energy. The Direct Energy (DE) represents the energy utilised by the manufacturing processes which includes pre-production, production and postproduction activities (e.g. casting, machining, spray painting, inspection, etc).

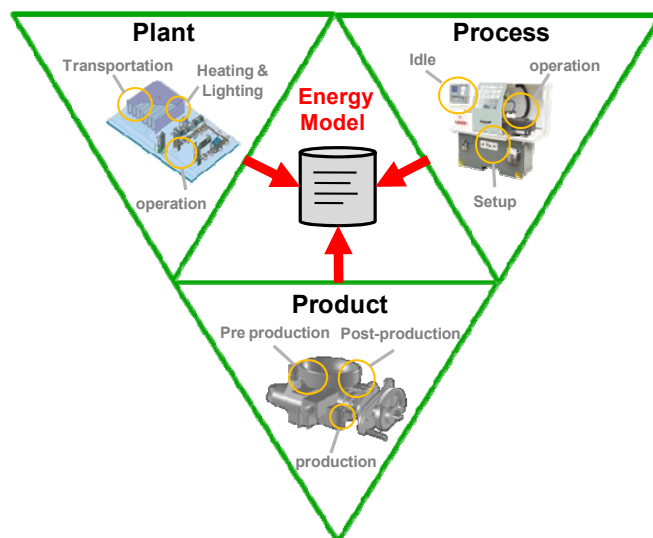

Figure 7.2: Integration of energy information from each of the ‘plant’, ‘process’ and ‘product’ perspective into a singular energy database

The Indirect Energy (IE) is the energy consumed by activities required to maintain the ‘environment’ in which the production processes are carried out within a production plant (e.g. lighting, heating, ventilation, etc.). The IE also extends to storage facilities like warehouses and cold storage rooms. The systematic attribution of IE and DE for all the processes required to manufacture a product provides the total embodied product energy which represents the sum of the DE and IE values for all processes used. An overview of the EPE framework is illustrated in Figure 7.3. A combination of theory or empirical studies is required to determine the values of the DE and IE and is further described in Chapter 8.

This framework combines energy consumption on a ‘plant’ perspective and on the ‘process’ perspective to determine the total EPE. A breakdown of IE and DE consumption for each process can support decision making involved in energy optimisation and rationalisation within a manufacturing facility. It is also possible to extend the framework to other non technical processes such as office administration, manual handling or transportation, however these are not considered in this thesis.

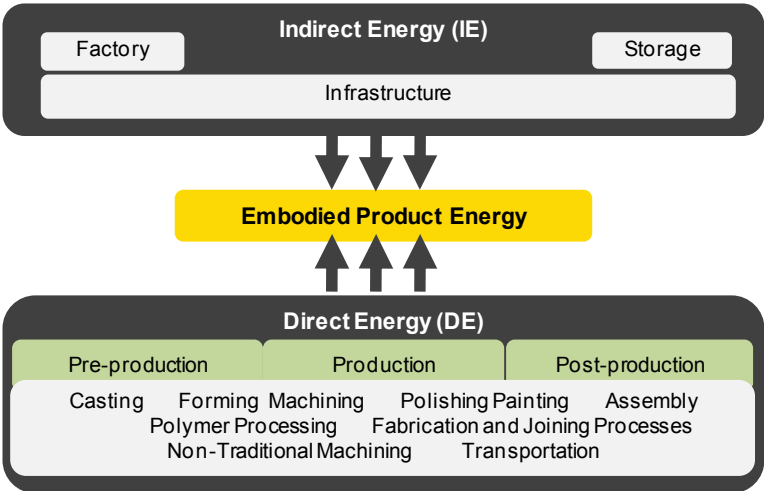

Figure 7.3: Overview of the framework showing the IE and the DE

A simple example of a product, i.e. an elbow pipe, has been used to illustrate the application of the framework in relation to the manufacture of a unit product. There are three processes required to manufacture the elbow pipe: casting, grinding and inspection. These are depicted in Figure 7.4.

7.4 Direct Energy

The Direct Energy (DE) is defined as the energy consumed by various production processes required to manufacture a product. In the EPE framework, the DE has been further divided into: (i) Theoretical Energy and (ii) Auxiliary Energy. The Theoretical Energy (TE) is defined as the minimum energy required to carry out a process (e.g. energy required to melt a specific amount of metal during casting or removing a specific amount of material during a machining operation). In most cases, the value of TE for a process can be calculated based on existing knowledge and/or appropriate mathematical models as shown in Chapter 4. In applications where the energy values cannot be calculated, TE can be estimated from previous empirical studies or literature such as SEC tables such as the one shown in Table 4.8.

The Auxiliary Energy (AE) is defined as the energy consumed by supporting activities and auxiliary equipment within a process (e.g. generation of vacuum for sand casting, or pumping of coolant for machining). In some production processes, the auxiliary energy can be significantly higher than the theoretical energy required for the process.

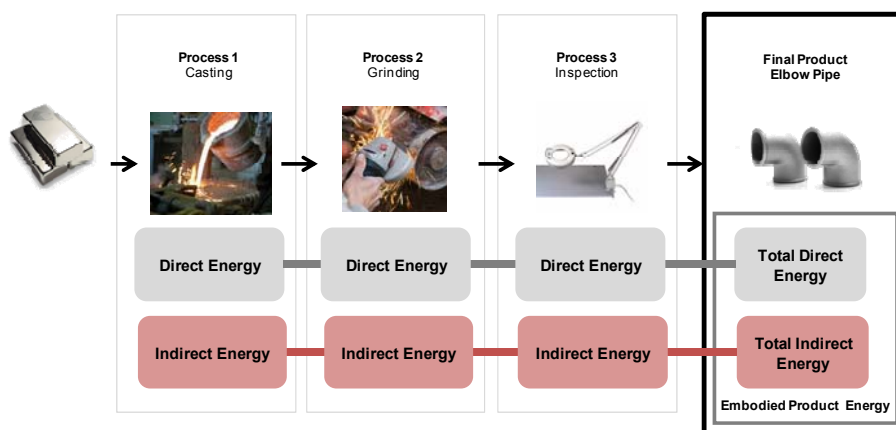

Figure 7.4: Manufacturing process of an elbow pipe.

The author also recognises that within some processes there are further divisions of energy consumption within Direct Energy; for example, the energy loss in the form of heat in the casting process or the waste energy in the form of noise and vibration within a cutting process.

However due to the requirements for the development of a generic framework for a large variety of production processes, this breakdown of energy wastage has not been included in the current EPE framework. This is because the energy consumed as a result of the wastage varies from process to process as well as from equipment to equipment. Its inclusion in a generic representation is therefore infeasible. In this research such energy inefficiencies can be represented in the calculation of the total energy consumption as described in Chapter 8.

In the case of the elbow pipe, the TE for Process 1 which is casting would be the energy needed to melt the metal during the casting process and the AE would be the energy required by auxiliary activities that supports the casting process such as the generation of vacuum for green sand moulding and the hydraulics required to lift the mould. The total direct energy for an elbow pipe is the sum of all the theoretical and auxiliary energies required by various processes needed to manufacture the pipe as depicted in Figure 7.5.

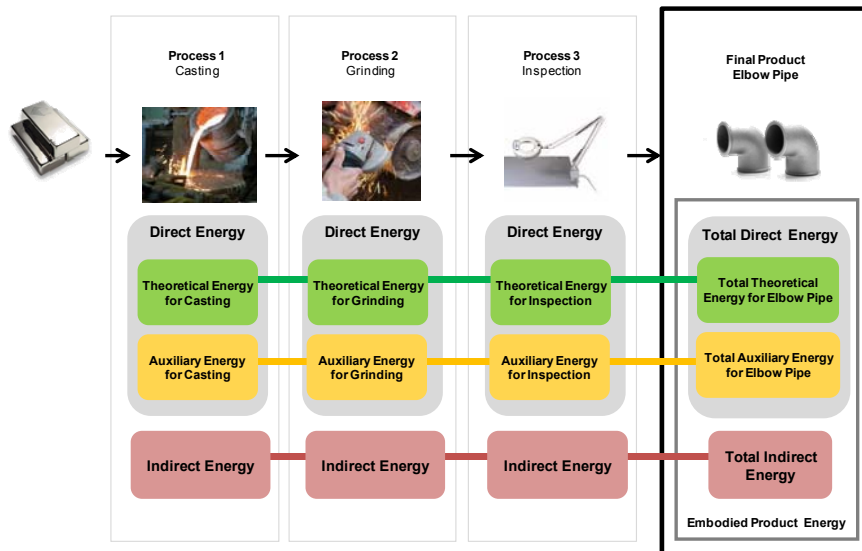

Figure 7.5: Direct energy required to manufacture an elbow pipe.

7.5 Indirect Energy

The Indirect Energy (IE) is the energy consumed by activities required to maintain the ‘environment’ in which the production processes are carried out. Broadly speaking, the IE for a product consists of the energy consumed by all the processes required to manufacture the product (note that storage and transportation between equipment can be also classified as individual processes). Products are typically manufactured in batches of various quantities, and therefore the IE needs to be attributed to a single unit as a function of throughput.

There are several ways of attributing the IE consumption to various processes within a factory. These are described in detail in Chapter 8. In this research, the attribution of IE is achieved through the definition of a manufacturing zone which is defined as an environment within a production facility (e.g. department, cell, clean room etc.) requiring uniform ambient energy. In the case of the elbow pipe, three manufacturing zones have been identified, as each process has different indirect energy requirements as shown in Figure 7.6. For the casting process heat extraction and ventilation fans and lighting are required, for grinding, environment air filtration and lighting are required and finally for inspection, standard lighting and ventilation are needed. The total IE for a product is the sum of IE required by each zone involved in the manufacture of the product for the period of manufacture.

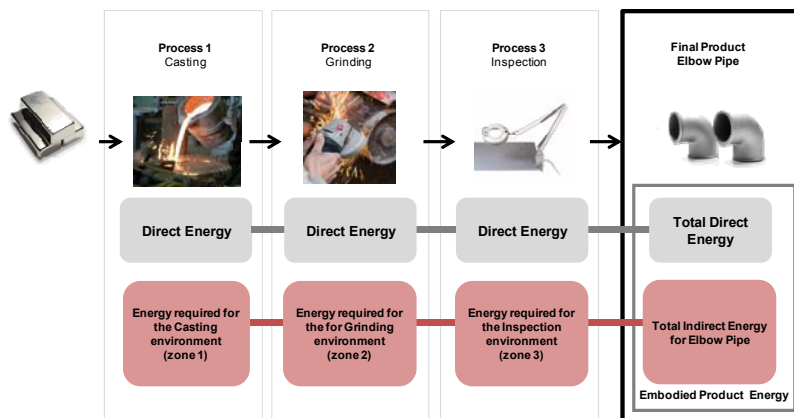

Figure 7.6: Indirect energy required to manufacture an elbow pipe.

7.6 Embodied Product Energy

The Embodied Product Energy is defined as the total energy required by the processes both on a direct level and indirect level. The term ‘Embodied Energy’ is typically used to define the energy spent in manufacturing a product, extraction of material, or to fulfil a service (Brown, 1996). In this thesis the term ‘Embodied Product Energy’ has been used to refer to the energy used in manufacturing products. The EPE framework allows the breakdown of energy consumption for each process to be clearly attributed to a product as illustrated in Figure 7.7. In this approach, each process can be established independently and brought together to provide a holistic picture of the overall energy consumption. The format also allows for other non-manufacturing processes to be evaluated using a similar template. For example the process of transportation of the finished goods to a warehouse for storage could be assessed in a similar manner to a production process requiring DE and IE and included within the framework. More detailed description of how each category of energy consumption is included in the calculations of total EPE will be provided in Chapter 8.

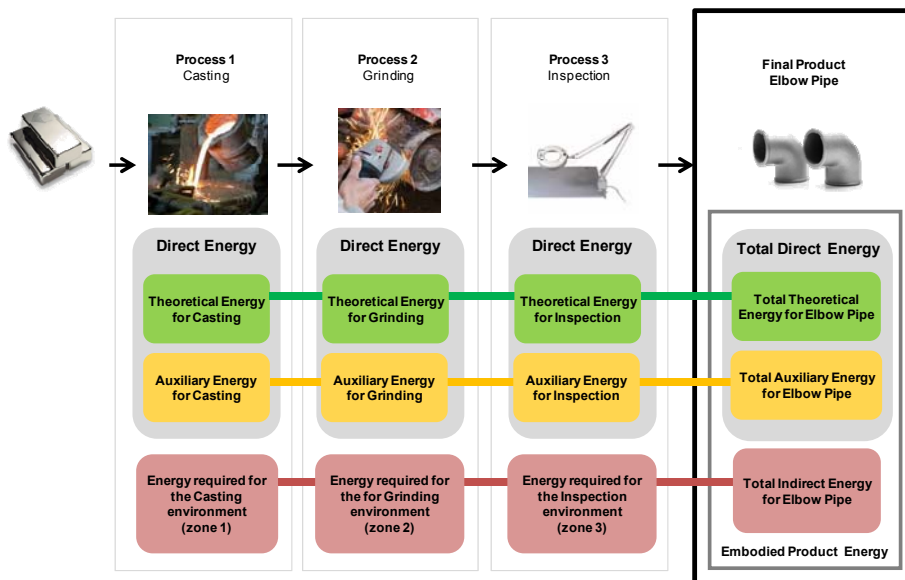

Figure 7.7: Total Embodied Product Energy of elbow pipe.

7.7 Key Assumptions made within the EPE framework

A number of assumptions have been made when putting the EPE framework together. One of the major assumptions is that the products analysed are produced through discrete manufacturing and that the energy consumed by the manufacturing system can be expressed in Joules. The framework does not account for manual labour as it is beyond the scope of this research. It also does not take into account the embedded energy within capital goods such as machinery, equipment and the building. The list of key assumptions have been summarised in Table 7.1.

Comment [Y6]: Assumptions1

Assumptions		Comments
1.	The energy consumed by the processes and activities can be expressed in the form of Joules	The International System of Units for energy is in Joules (J).
2.	The energy consumed in a manufacturing facility can be broadly categorised into Direct and Indirect Energy	Literature reviewed in this area have made similar classifications to energy consumption in manufacturing facilities.
3.	Manual labour does not contribute to the embodied energy of the products within this framework	Energy expended by a person is difficult to account for and as such has been excluded from the framework.
4.	Non manufacturing processes such as administrative activities can be evaluated as a process and the energy can be attributed to products in a similar fashion.	Administrative activities can be viewed as a process with a IE and DE component (e.g. for clerical work the IE would be air-conditioning and the DE would be the energy consumed by the computers)
5.	The products analysed through the framework are produce through discrete manufacturing	The scope of the framework has been limited to just discrete manufacturing as most consumer products (toys, cars, consumer electronics etc.) are produced in this manner.
6.	Energy embedded in the machines, equipment and building are not accounted for in the embodied energy.	The focus of the framework is to establish the energy embodied in the product being manufactured and not the equipment that makes it.
7.	The indirect energy can be attributed to an area and the throughput of that area is known so that the average indirect energy consumption per part can be established.	Indirect energy can be calculated based on the types of energy consuming equipment present to maintain the environment of the area or by taking energy readings of the equipment in that area.

Table 7.1: List of assumptions in the EPE Framework.

7.8 Chapter Summary

This chapter has introduced the energy modelling framework which is based on the definition of the Direct Energy and the Indirect Energy. The DE can be further divided to the Theoretical Energy and Auxiliary Energy required by production processes. The energy consumed by a manufacturing facility is accounted for by attributing the process to a zone which is an area with uniform ambient energy requirement. The total embodied product energy is the sum of the DE and IE. Detailed considerations of DE (the methods of deriving data) and the IE (e.g. attribution of IE to multiple product streams) within the framework is discussed in the next chapter.

Chapter 8 Modelling Direct Energy and Indirect Energy

8.1 Introduction

The previous chapter provides an overview of the EPE framework. In this chapter, the calculations of DE and IE within the framework will be explained along with the various methods of obtaining relevant energy data. Also further energy analysis of the product, process and plant are introduced in the form of “energy efficiency ratios”. An example is also used to demonstrate how DE and IE are calculated.

8.2 Modelling Direct Energy and Indirect Energy

As outlined in Chapter 7 the EPE framework is based on two main categories of energy consumption i.e. Direct Energy (consisting of Theoretical and Auxiliary energy) and Indirect Energy. An overview of the EPE framework in relation to the manufacture of Product *A* with *n* production processes is shown in Figure 8.1. The calculation of DE and IE is based on the data for energy consumption which is mainly electrical energy. In line with most life cycle analysis methods, the energy required for manual activities (e.g. manual assembly) has been excluded from the scope of this research. The methods for data collection required by the EPE framework will be discussed in greater detail in the next section of this chapter.

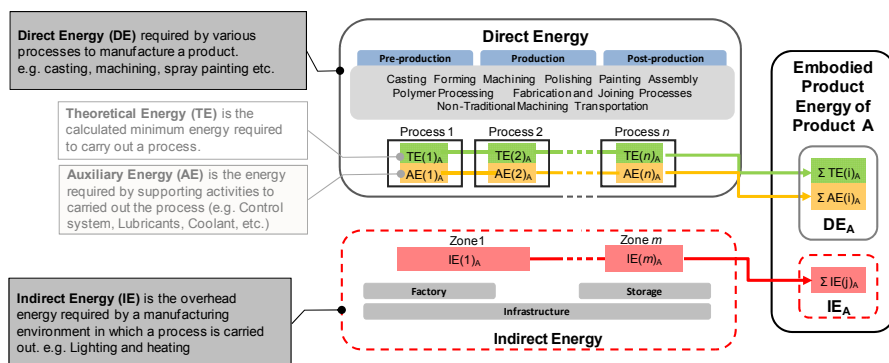

Figure 8.1: Overview of energy the Embodied Product Energy framework

8.3 Data collection for EPE framework

The accuracy of the calculated values for DE and IE to a large extent is dependent on the availability and quality of data on energy consumption within a manufacturing facility. In addition, the source and the quality of the input data would impact the relevance of the results to a specific manufacturing system. There are three main methods identified by this research for collecting (or generating) the energy data for modelling DE and IE:

- i. Empirical measurements,
- ii. Use of published data and,
- iii. Use of mathematical models.

In practice, the most preferred method will be to directly measure the energy used by each production process and the supporting activities within the manufacturing facility. However the number and the range of processes and the variety of the supporting activities used within a typical production system makes this infeasible. Therefore, in cases where such information cannot be obtained through direct measurements, it is possible to utilise the data that is published in previous studies or available through the equipment manufacturer, as long as the variations/relations with process being considered are known and understood. In some applications where the data is not available through empirical studies or published sources, a mathematical model for the energy consumption within a process can be developed. The appropriate methods of data collection for TE, AE and IE are included in a flow diagram as shown in Figure 8.2. It should be noted that in most cases, the empirical data may differ from the values obtained from the mathematical models, as in practice most processes require more energy due to losses from friction, heat and other inefficiencies.

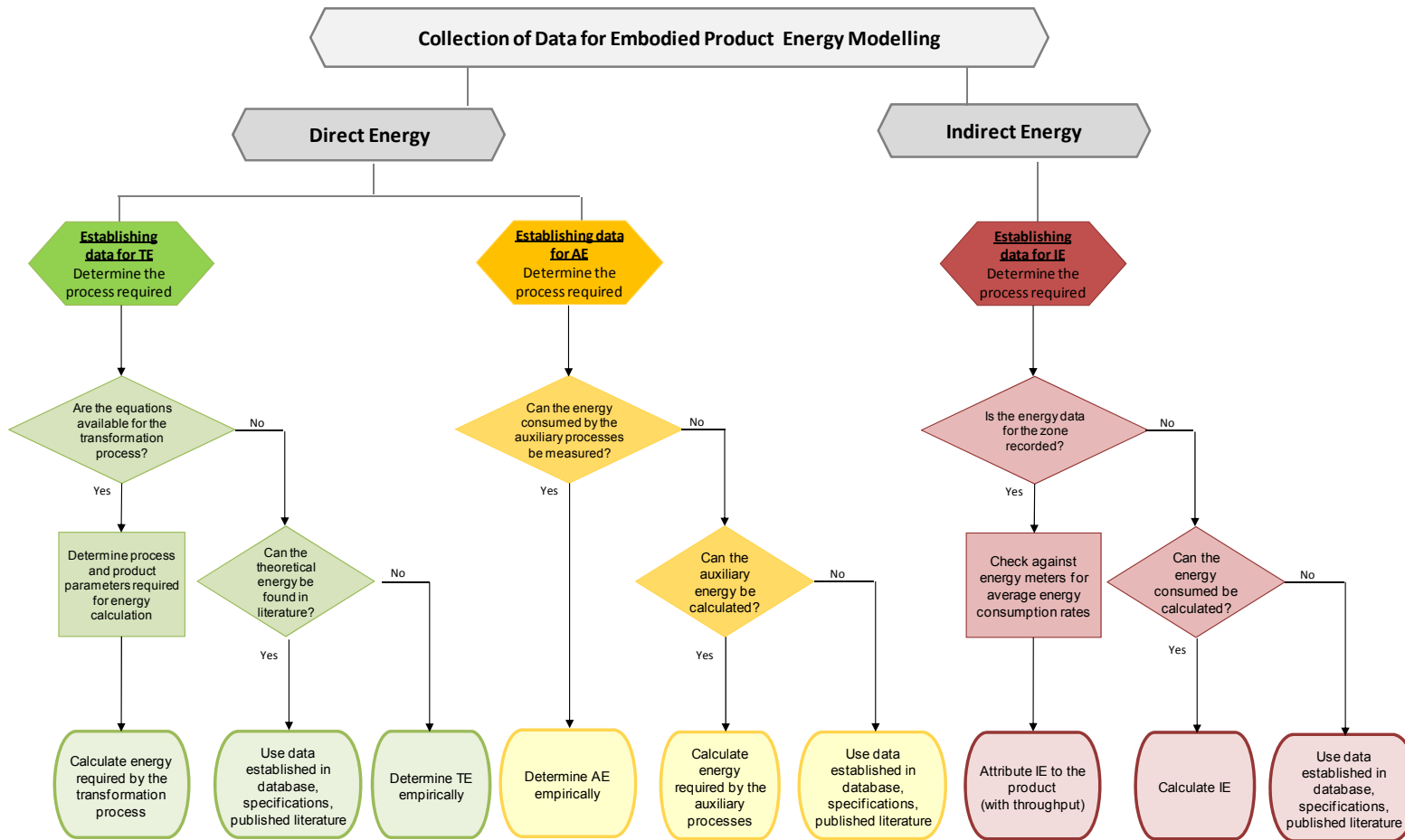

Figure 8.2: Establishing the data collection method for TE, AE and IE

8.3.1 Empirical Measurements

The most appropriate method of customising an energy model for a manufacturing facility is through directly collecting energy data for various production processes. This can be achieved through the use of simple energy meters with or without data loggers to measure the electricity consumption of the production processes, the supporting activities and services required by the factory infrastructure.

An example of an energy meter is the Chauvin Arnoux C.A 8335 Qualistar Plus which provides an on screen graphical display of the energy consumed and enables data to be logged and recorded, as shown in Figure 8.3. It can provide real time displays of the energy consumption and also record data which can be exported to a PC. A dedicated data logger can also be used which is more cost effective. Figure 8.4 shows an example of a Chauvin Arnoux data logger L562 monitoring voltage and current in a load centre.

Another method of obtaining energy data is through industrial smart meters used in empirical studies of processes. This is an integrated system composed of sensors, processors and analysers to capture, transfer, and identify energy flows in manufacturing systems. Smart metering tracks not only the energy consumed but also the characteristics of the specific power consumption over time, enabling different operating states to be identified. This enables the distinction between the theoretical and auxiliary energy used by a process.



Figure 8.3: The Chauvin Arnoux C.A 8335 Qualistar Plus and the graphical outputs when used with the Dataviewer Pro



Figure 8.4: A Chauvin Arnoux data logger recording energy data off a load centre

Therefore the ability to generate the power profile using energy data enables us to distinguish between the amount of energy used to carry out the process and the energy used by supporting activities. For example a typical power profile generated through a smart metering system has been illustrated in Figure 8.5. This indicates the total energy used within a machining cycle with the variations in the power profile indicating the Theoretical and Auxiliary energy used by the machine tool within a machining cycle. TE is the minimum energy required to carry out the transformation process which in the case of milling is the Tip energy (energy used by the tool tip to cut the metal). The rest of the power consumed is due to energy required during the start up and idle phases which is classed as Auxiliary Energy within the EPE framework.

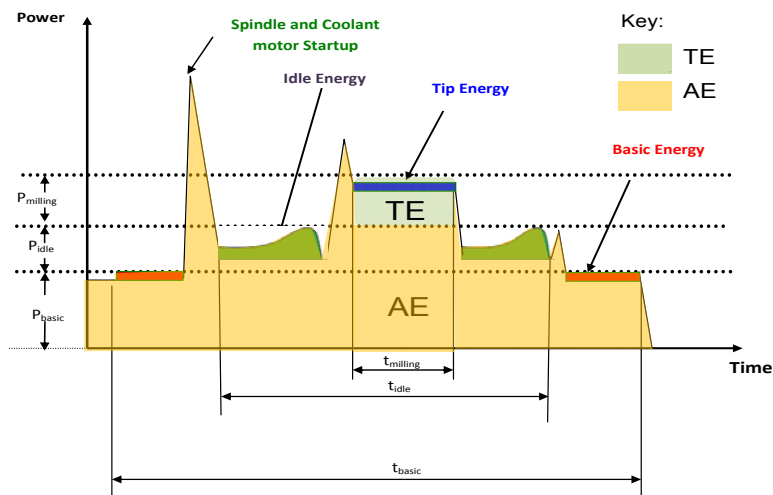

Figure 8.5: Power profile graph show with the area under the graph in green denoting the TE and the yellow are denoting AE.

8.3.2 Use of Published Data in EPE Framework

Although the use of empirical data provides the most accurate method of measuring the DE and IE values, in most applications the attainment of a complete set of energy data through this method is unfeasible due to complexity, cost and available resources. In such cases, the use of published or available data from various sources should be considered. There are a growing number of energy inventory databases such as UPLCI and CO₂PE! (see Section 4.6) that are being generated through international research activities. Table 8.1. provides a list of similar databases that provide energy data for a range of processes. This provides a convenient method to access a large amount of energy data for a wide range of production processes that are being considered in these studies.

Another source of energy data is available from a large number of past research related to energy analysis of various production processes. A comprehensive list of such publications has been identified by this research and is summarised in Table 8.2. However, it should be noted that the majority of these research have adopted a list of assumptions in their studies. The relevance of these assumptions for the case of the production process being modelled needs to be carefully considered.

Focus	Name of Data or Source	Type (book/database)	Creator/ Authors
Processes	Unit Process Life Cycle Inventory, UPLCI	Database cratel.wichita.edu/uplci/	Wichita State University
	Cooperative Effort on Process Emissions in Manufacturing, CO ₂ PE!	Database www.mech.kuleuven.be/co2pe!/index.php	University of Leuven
	Energy Analysis of 108 Industrial Processes	Book	Brown <i>et al.</i> (1985)
	Energy Analysis of Thermal Chemical and Metallurgical Processes	Book	Szargut <i>et al.</i> (1988)
	Energy Efficiency in Motor driven systems	Book	Parasiliti and Bertoldi (2003)
Materials	Inventory of Carbon and Energy, ICE	Database www.bath.ac.uk/mech-eng/serf/embodied/	University of Bath
Materials and Processes	EcoInvent2000	Database www.ecoinvent.ch	Swiss Centre for Life Cycle Inventories
	Manufacturing Processes for Engineering Materials (5 th eds)	Book	Kalpakjian and Schmid (2008)

Table 8.1: List of sources for process and material energy information

Domain	Area	Reference
Process	Wafer fabrication	Murphy <i>et al.</i> (2003)*
	Nanoscale manufacturing	Zhang <i>et al.</i> (2006)*
	Carbon nano fibre production	Khanna <i>et al.</i> (2008)*
	Semiconductors	Williams <i>et al.</i> (2002); Branham (2008)*
	Injection Moulding	Mattis <i>et al.</i> (1996)*
	Sand casting	Dalquist and Gutowski (2004)*; Schifo and Radia (2004)
	Grinding	Baniszewski (2005)*; Ghosh <i>et al.</i> (2008)
	Laser Machining	Chryssolouris (1991) *
	Metal Cutting	Sandvik Coromant (1996)*
	Bandsawing	Sarwar <i>et al.</i> (2009)
	Machining	Munoz and Sheng (1995) *
	Cold Forming	Kuzman and Peklenik (1990)
	Steel forging	Kubo <i>et al.</i> (1999)
	Waterjet machining	Kurd (2004)*
Machine Equipment	Machining	Toenissen (2009)*
		Dahmus and Gutowski (2004)*
		Kordonowy (2001)*
		Vijayaraghavana and Dornfeld(2010)
Herrmann <i>et al.</i> (2007)		
Injection moulding	Devoldere <i>et al.</i> (2008)	
	Draganescu <i>et al.</i> (2003)	
	Thiriez and Gutowski (2006)*	
Electric Motors	Joseph (2003)	
	Kanungo and Swan (2008)	
		El-Ibiary (2003)

Table 8.2: List of published research work on energy consumption of processes and equipment (*indicate studies that have been compiled by Gutowski *et al.*, 2009)

8.3.3 Use of Mathematical Modelling to Generate Data for EPE framework

Another method of ascertaining energy data is via a theoretical approach to model the energy used by production processes. Mathematical equations (some of which are based on first principles) can be used to calculate the energy requirements from a range of parameters such as mass, temperature, hardness, and other processing variables.

For example in the casting process, the energy, E , required for melting a specific material can be calculated using the Equation 8.1 (Ashby, 2008):

$$mc(T_m - T) + mL \quad \text{[Equation 8.1]}$$

Where,

m : Mass (kg)

C : Specific heat capacity (kJ/kgK)

T_m : Melting temperature (K)

T : Temperature of metal before melting (K)

L : Latent heat of melting (kJ/kg)

For some processes such as cutting, specific energy consumption values (energy consumed per unit of material processed) for various material types have been established through empirical studies (Kalpakjian, and Schmid, 2008) and the energy requirements for that process can be established by using the specific energy consumption values multiplied by the amount of material processed. Whilst these models may not always be an accurate representation of the actual case being analysed due to the use of a singular energy consumption rate, they serve to provide a good approximation of energy data in the absence of empirical energy data.

A similar approach can be adopted to calculate the total IE used by a facility through a mathematical model. For example the energy required to heat a room can be established through heat transfer equations as shown in Equation 8.2 (Lienhard and Lienhard 2008):

$$q'' = h(T_s - T_\infty) \quad \text{[Equation 8.2]}$$

Where,

q'' : conductive heat flux (W/m^2)

h : convection heat transfer coefficient (W/m^2K)

T_s : surface temperature (K)

T_∞ : fluid temperature (K)

Some commonly used processes and the respective simplified energy equation is summarise in Table 8.3. The energy equations are an approximation of the basic energy requirement (i.e. energy for melting, bending, vaporising etc) and more accurate mathematical models can be used if known. These simplified mathematical models can be used within the EPE framework, in two different ways:

Comment [Y7]: Changed sentence

- i. In applications where the energy data cannot be obtained through empirical studies and are not available within published literature. In such cases, through identification of appropriate process parameters, the TE, AE and IE for a process can be calculated using the appropriate mathematical model.
- ii. In cases where the total energy used for a process has been determined through an empirical study, however the independent measurement of the TE and AE do not correlate. In such applications, the value of TE can be established through the use of appropriate mathematical calculations, which in turn enables the deduction of AE for that process. Again, this could also be applicable to IE.

Process Technology	Process Type	Example	Energy requirement	Equation	Reference
Forming	Metal Casting and heat treatment processes	Sand Casting	Energy to melt metal	$mc(T_m - T) + mL$ <i>m</i> : Mass (kg) <i>C</i> : Specific heat capacity (kJ/kgK) <i>T_m</i> : Melting temperature (K) <i>T</i> : Temperature of metal before melting (K) <i>L</i> : Latent heat of melting (kJ/kg)	Ashby et al., 2008
	Processing of metal powders, ceramics, glasses and superconductors	Sintering	Energy to melt material		
	Processing of polymers	Injection moulding	Energy to melt the polymer		
	Bulk deformation processes	Forging	Energy to deform/bend metal		
Cutting	Material removal processes	Machining	Specific energy requirements in machining	UV <i>U</i> : specific cutting energy (kJ/m ³) <i>V</i> : volume of part to be removed (m ³)	Kalpajian, and Schmid, 2008
	Material removal processes – abrasive, chemical, electrical and high energy	EDM	Energy to vaporise material	mL_v <i>m</i> : Mass (kg) <i>L_v</i> : Latent heat of vaporisation (kJ/kg)	Ashby et al., 2008
Joining	Joining and fastening processes	Welding	Energy to melt metal	$mc(T_m - T) + mL$ <i>m</i> : Mass (kg) <i>C</i> : Specific heat capacity (kJ/kg) <i>T_m</i> : Melting temperature (K) <i>T</i> : Temperature of metal before melting (K) <i>L</i> : Latent heat of melting (kJ/kg)	Ashby et al., 2008

Table 8.3: Establishing the Theoretical and Auxiliary Energy for some common processes.

8.4 Calculation of Total DE within EPE Framework

Once the TE and AE for a process have been established either from one or a combination of the three data collection methods described in Section 8.3, the sum of the TE and the AE represents the total Direct Energy for that process, as shown in Figure 8.6.

Typically within a production system, a number of processes are required to manufacture a product. Assuming a product requires n processes, the total Direct Energy required to manufacture a product can be represented as shown in Equation 8.3:

$$DE_A = \sum_{i=1}^n (TE(i)_A + AE(i)_A) \quad \text{[Equation 8.3]}$$

Where:

DE_A is the total Direct Energy associated with Product A ,

$TE(i)_A$ is the Theoretical Energy of Process i associated with the manufacture of Product A ,

$AE(i)_A$ is the Auxiliary Energy of Process i associated with the manufacture of Product A .

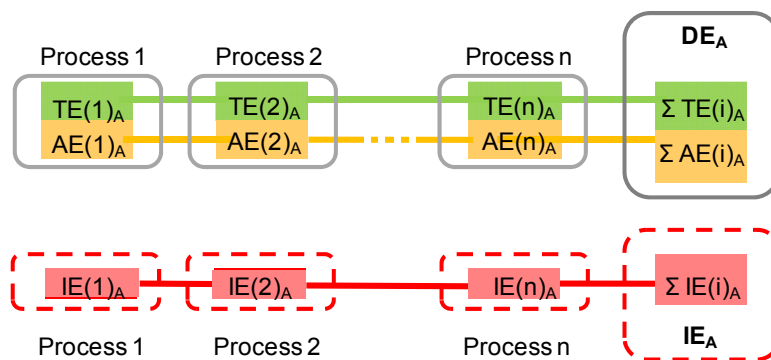

Figure 8.6: Calculating Direct Energy is the sum of all TE and the AE for the processes required to manufacture Product A .

8.5 Calculation of Total Indirect Energy within EPE Framework

Each process within a production system requires a specific environment in which to operate, and therefore consumes a certain amount of Indirect Energy. The total IE for a production system is the sum of these individual IE values for various processes as shown in Figure 8.6.

There are several ways of attributing a proportion of this total IE required to manufacture a unit product. The first and the most basic method is to divide the total IE value by the number of products produced for a specific period thus averaging the energy consumed by the infrastructure and services to each product manufactured.

The second, more accurate but more complex method is based on two stages. In the first stage the total indirect energy is apportioned to the floor area and/or volume of space occupied by a single piece of processing equipment or a number of pieces of processing equipment within a manufacturing cell. In the second stage, the IE attributed to each process (or a group of processes) is divided by the total number of products going through that process or cell. These two methods are described in more detail in Appendix 1.

The research reported in this thesis has adopted a hybrid of these two methods through the definition of manufacturing zones which are defined as an area with uniform ambient energy requirements (e.g. similar lighting, heating and ventilation requirements). In this method the IE for each manufacturing zone is identified and calculated, and then this IE value for each zone is divided by the number of products processed in that zone for a specific period, as depicted in Figure 8.7. This figure illustrates a case with two manufacturing zones for a specific period during which six products are processed in Zone 1 and four are in Zone 2. The machining and polishing processes in Zone 1 require similar lighting intensities and ventilation whereas the inspection process requires higher lighting intensities as well more effective air-conditioning.

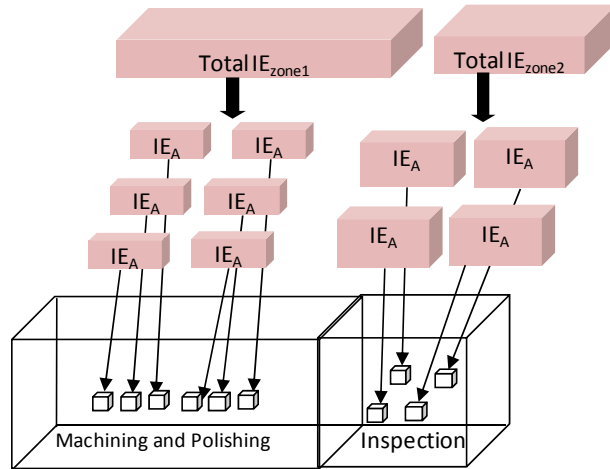

Figure 8.7: IE is attributed to the product based on the zone it is produced in

In this approach, the IE attributed to product A in zone x (i.e. $IE_{zone(x)A}$) can be calculated based on total Indirect Energy consumed within zone x (i.e. $IE_{zone(x)T_y}$) within a specific time frame, T_y (where T_y can be an hour, a shift, a week) divided by the total throughput of Product A through Zone X ($TP_{zone(x)T_y}A$) for time frame T_y , as expressed in Equation 8.4:

$$IE_{zone(x)A} = IE_{zone(x)T_y} / TP_{zone(x)T_y}A \quad \text{[Equation 8.4]}$$

Where,

$IE_{zone(x)A}$ is the indirect energy attributed to Product A for Zone x during time T_y

$IE_{zone(x)T_y}$ is the indirect energy consumed by zone x during time T_y

$TP_{zone(x)T_y}A$ is the throughput of Product A through zone x during time T_y

Consequently, the total Indirect Energy required by Product A requiring m manufacturing zones can be represented as Equation 8.5:

$$IE_A = \sum_{j=1}^m IE_{zone(j)A} \quad \text{[Equation 8.5]}$$

8.6 Calculation of Embodied Product Energy (EPE)

The previous sections have detailed the methods to calculate the total DE and IE required to manufacture a product. Thus, the total Embodied Product Energy for Product A (i.e. EPE_A) is the sum of the total DE and IE consumed during the manufacture of Product A , as depicted below:

$$EPE_A = \sum_{i=1}^n DE(i)_A + \sum_{j=1}^m IE_{zone(j)A} \quad \text{[Equation 8.6]}$$

This equation can be further expanded to include the values of TE and AE as depicted in Equation 8.7 (see Equations 8.3 and 8.6).

$$EPE_A = \sum_{i=1}^n (TE(i)_A + AE(i)_A) + \sum_{j=1}^m IE_{zone(j)A} \quad \text{[Equation 8.7]}$$

The calculations for total Embodied Product Energy for Product A are illustrated in Figure 8.8.

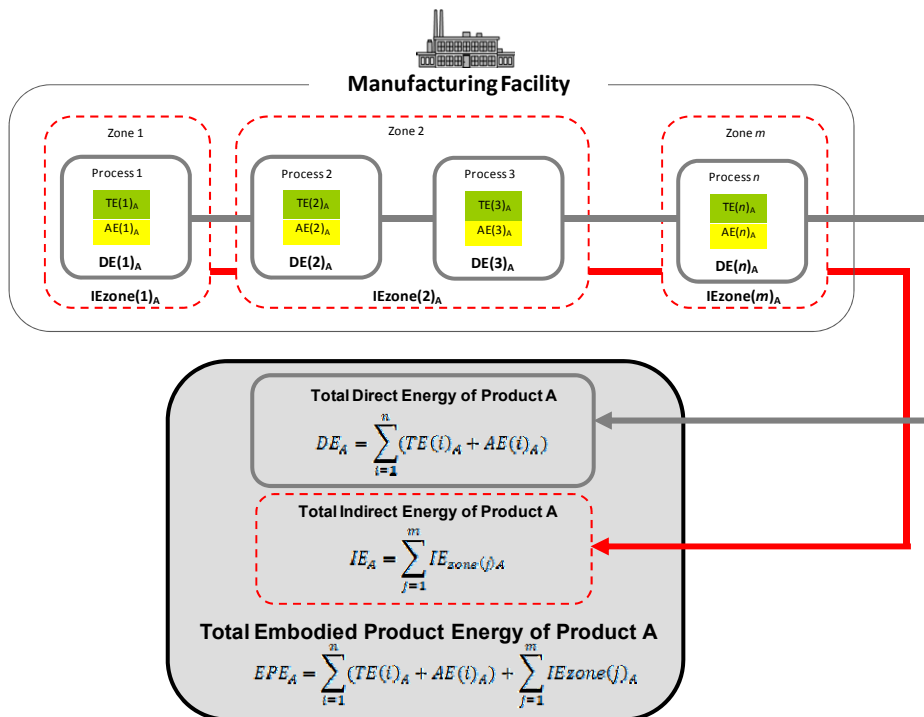

Figure 8.8: A graphical representation of the EPE framework showing the sum of the TE, AE and IE to establish the embodied product energy of Product A

8.7 Defining Product, Process and Plant Efficiency Ratios

The assessment of a product's environmental performance involves a range of considerations and is often a difficult and complex task. The comparison of energy performance of a product simplifies this process providing a more focused scope for assessment. In recent years, there has been an increase in the number of energy labels that have been applied to products. These energy labels (e.g. EU label and the US Energy Star) have provided consumers with energy information about the performance of the product in relation to energy through efficiency ratings. The implementation of these labels through legislation and policies has empowered consumers to select products with higher energy efficiencies. In addition, manufacturers are increasingly forced to improve the energy efficiencies of their products in order to remain competitive. However these energy labels only provide an indication of the energy efficiency of the products during the 'use' phase. Policy makers are increasingly aware of the need to ensure energy efficiencies are established throughout the life cycle of the product by encouraging efficiencies during the production phase of these products. Thus, energy management standards such as ISO 50001 (ISO, 2010) have been implemented to help manufacturers monitor and reduce energy consumption within their facilities. Energy labelling and benchmarking have also recently been expanded to cover production facilities (Plant Energy Performance Indicator), however for such complex and integrated systems, comparisons of overall energy use can be difficult as each facility is often unique in the services required and the range of products produced.

The author asserts that the evaluation of energy consumption of a manufacturing system through a product perspective as proposed in this research enables the energy efficiency of processes, plants and product to be evaluated within the production phase of a product life cycle. Using the product as a functional unit, the energy used by the processes or production system can be assessed for energy productivity which is defined as energy that "add value" during the production of the product. To achieve this, a number of ratios relating to TE, DE, and IE have been identified. The ratios compare the productive energy versus non-productive energy and enable the efficiency of a process and production system to be quantified. These ratios are described in the next sections of this chapter.

8.7.1 Process Efficiency Ratio

In this research, 'process' is referred to as a manufacturing process which can be supported by a number of machines to undertake an activity. For example, the process efficiency of a cutting process with just a single 5 axis CNC machine would depend on the efficiency of the single machine. In a process supported by more than one resource, such as an assembly line, the process efficiency is thus dependant on the efficiency of the individual machines summed together. For simplicity, it is assumed that 1 process is supported by 1 primary resource (i.e. machine). Complex processes can be viewed as a number of smaller processes which can be evaluated individually. The process efficiency ratios therefore assess the productivity of the resource used to support the process.

Comment [Y8]: Change 7

The minimum energy (i.e. the Theoretical Energy) required by the process is compared against the energy required by the resource (i.e. the Direct Energy). The comparison of the theoretical energy required for a process and the total direct energy consumed by the resource carrying out the activities indicates the proportion of energy that has created "added-value". Therefore the Process Efficiency Ratio for a process n when manufacturing Product A , $ER_{process(n_A)}$ is defined as TE divided by DE. The value of this ratio is always between 0 and 1, as shown in Equation 8.8. A higher value of $ER_{process(n_A)}$ (i.e. values closer to 1) is indicative of a smaller percentage of AE, and therefore signifies a more efficient process.

Conversely, a lower value of $ER_{process(n_A)}$ (i.e. values closer to 0) denotes an energy inefficient process. A graph of these ratios for various processes required to manufacture a product, as depicted in Figure 8.9 can easily be used to identify the inefficient processes which require further consideration, improvements and possible investment throughout a product's process chain.

$$0 < ER_{process(n_A)} = \frac{TE_{(n_A)}}{DE_{(n_A)}} < 1 \quad \text{[Equation 8.8]}$$

Where,

$ER_{process(n_A)}$ is the process efficiency ratio for process n when manufacturing product A

$TE_{(n_A)}$ is the theoretical energy required by process n when manufacturing product A

$DE_{(nA)}$ is the direct energy required by process n when manufacturing product A

The overall $ER_{process(A)}$ for a product can also be determined by replacing the TE and DE values of the individual processes for the overall TE and DE values for the product as shown in Equation 8.9. This would provide an indication of the overall productivity of the processes used to manufacture product A.

$$0 < ER_{process(A)} = \frac{TE_A}{DE_A} < 1 \quad \text{[Equation 8.9]}$$

Where,

$ER_{process(A)}$ is the process efficiency ratio for the manufacture of Product A

TE_A is the total theoretical energy required during the manufacture of Product A

DE_A is the total direct energy required during the manufacture of Product A

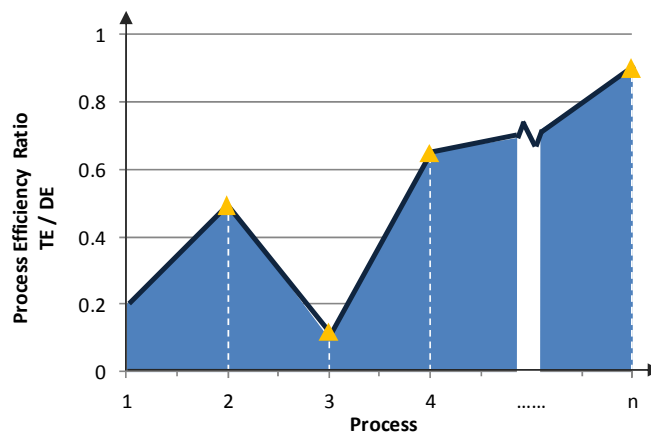

Figure 8.9: Graphical plot of the process efficiency ratios for n processes

8.7.2 Product Efficiency ratio

Similarly, the “Product Efficiency Ratio” ($ER_{product}$) compares the total theoretical energy required in the manufacture of a product to the total embodied product energy consumed during the production phase. The $ER_{product}$ indicates the proportion of productive energy that has “added-value” in the manufacture of the product. The $ER_{product}$ is determined by the ratio of the total TE of the product over the total EPE of the product and is between 0 to 1, as shown in Equation 8.10. A higher value of $ER_{product}$ (i.e. values closer to 1) indicates a smaller percentage of energy was consumed by the auxiliary and indirect processes and activities, thus in general signifying greater

efficiencies of the processes used to manufacture the product. On the other hand a lower value (values closer to 0) of the $ER_{product}$ means that a large amount of energy was unproductive (i.e. non-value adding) during the manufacture of the product. This could be due to inefficient processes and/or non-value adding activities and services such as lighting, heating and ventilation. The ratios for each product can be plotted in a graph to compare the efficiencies between the products, see Figure 8.10.

$$0 < ER_{product(A)} = \frac{TE_A}{EPE_A} < 1 \quad \text{[Equation 8.10]}$$

Where,

$ER_{product(A)}$ is the process efficiency ratio for product A

TE_A is the theoretical energy required by product A

EPE_A is the embodied product energy of product A

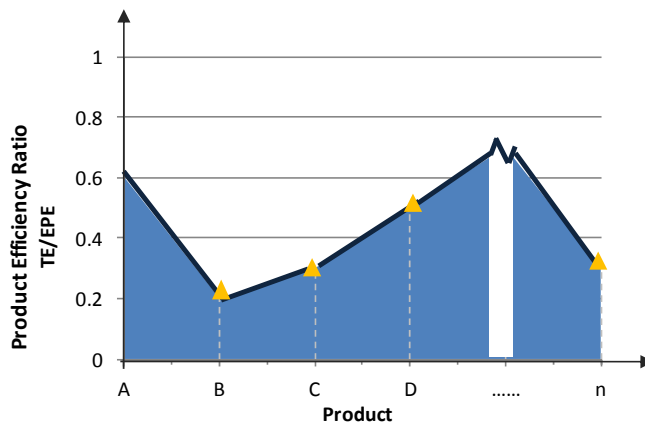

Figure 8.10: Graphical plot of the product efficiency ratios for n products

8.7.3 Plant efficiency ratio

Lastly, the “Plant Efficiency Ratio”, ER_{plant} is the ratio of the total direct energy required to manufacture a product to the embodied product energy of the product. The ER_{plant} indicates the proportion of energy that has been used for the processes required to manufacture a specific product over the total energy consumed by a production plant/system during the manufacture of that specific product. Like the previous two ratios, the ER_{plant} is between 0 to 1 as shown in Equation 8.11, where values closer to 1 indicate minimal indirect energy consumption by the services required by the facility infrastructure compared to the production process and is hence indicative of an efficient

production plant/system. Low values of ER_{plant} (values closer to 0) however indicate that a large proportion of energy is consumed by non value-added activities (i.e. the indirect energy consumers such as lighting, heating, ventilation) and signifies ineffective use of energy during production.

$$0 < ER_{plant(A)} = \frac{DE_A}{EPE_A} < 1 \quad \text{[Equation 8.11]}$$

Where,

$ER_{plant(A)}$ is the plant efficiency ratio for a plant or production system during the manufacture of Product A

DE_A is the total direct energy required in the manufacture of product A

EPE_A is the embodied product energy of product A

In companies where the production activities are within a single production plant, the ER_{plant} is a clear indication of the efficiency of the production plant which may be used in a benchmarking exercise as a comparison against other companies as shown in Figure 8.11. In industries where the manufacturing activities are based on a number of production lines or systems (e.g. within the food sector), it is also possible to compare the efficiency of manufacturing systems within a plant.

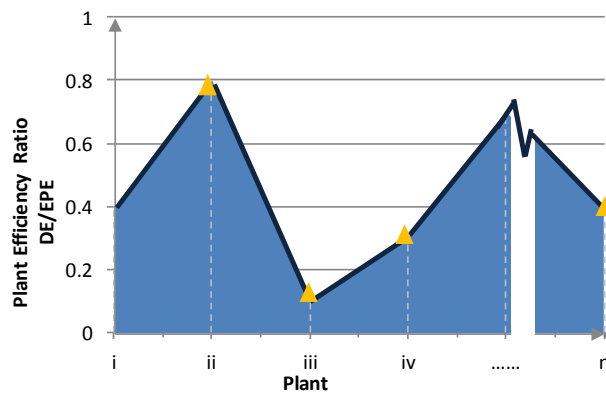

Figure 8.11: Graphical plot of the plant efficiency ratios for n manufacturing systems.

8.8 Chapter Summary

This chapter has presented the detailed calculations required to establish the embodied product energy within the framework proposed in this research. Based on these energy values, a number of simple but useful energy efficiency ratios have been defined to determine the productivity of the individual process, production system as well as the overall efficiency in relation to a product. The ER_{process} can be used to assess the inefficiencies introduced through non-productive auxiliary energy, the ER_{plant} can be indicative of the inefficiencies through the indirect energy and finally the ER_{product} highlights both the inefficiencies caused by the auxiliary and indirect energy. The complexities involved in the implementation of these calculations within a typical production system with multiple products clearly highlight the need for the support of a computerised system. The flexibilities offered by existing simulation modelling software has been utilised to develop appropriate software support. The design and implementation of this energy simulation model will be discussed in Chapter 9.

Chapter 9 Development of the Energy Simulation Model

9.1 Introduction

This chapter describes the design and implementation of a simulation model that has been generated to support the application of the EPE modelling framework within complex manufacturing systems. This energy simulation model can be used to consider a number of ‘what-if’ scenarios for optimisation and improvement in energy efficiency in manufacturing applications. In addition, the flexibility offered by simulation techniques enables a wide range of variation representing process routes, batch sizes, production lead times, queuing times, etc. to be incorporated within the model. The initial sections of this chapter provide an overview of the model and describe the system functionality. The latter sections outline the various outputs generated by the simulation model. A case study is used in Chapter 11 to demonstrate capability of the energy simulation model.

9.2 Energy Simulation Model

In the Energy Simulation Model (ESM) various processes are defined as events, products as entities, buffers as queues, product and processing data as attributes and energy consumed by the products are defined through variables, as depicted in Figure 9.1.

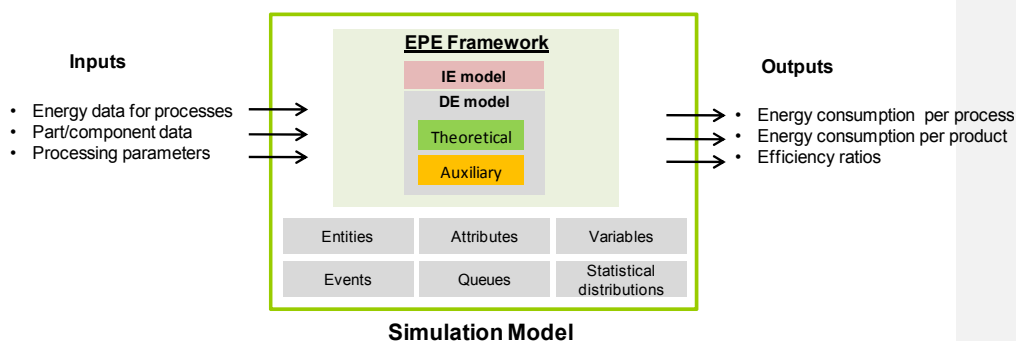

Figure 9.1: Inputs and outputs from the simulation model

Statistical distributions can also be allocated within the simulation model to represent batch sizes, processing and queuing times, etc. The ESM model receives input data related to part and processing parameters and generates outputs in the form of energy data such as energy consumption per process and product as well as efficiency ratios.

In practice, different batches of products may be manufactured. The use of a simulation model provides the additional functionality to address different batch sizes and the impact it would have on overall energy consumption and thus the embodied energy per product can be established. In addition different product types that have a similar process chain (i.e. require same resources) can also be analysed and the impact of different product features on energy consumption can also be examined.

Comment [Y9]: Changes 5.1

For example a larger batch size, could result in the reduced frequency of the set up and therefore lead to energy savings from the elimination of multiple machine start ups. The benefit of scale not only reduces material and labour costs but also energy costs as the indirect energy of the process would be attributed to a larger quantity. The simulation model can be used to assess the impact of varying batch sizes on embodied energy per product through the function of throughput time. This can allow the user to compare energy efficiency between achieving economies of scale and economies of scope.

9.2.1 Users of the model

The model can be tailored for a range of users due to the flexibility of the system. However it is believed that the main users of the model would primarily be designers and engineers. Designers who have an interest in understanding the energy consumption associated with a particular product can use the model to establish overall energy data for a product. Figure 9.2 shows illustrates how various batch sizes may have different EPE values even when going through similar process chains.

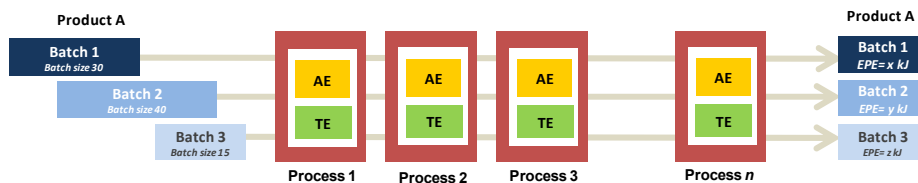

Figure 9.2: The model can help with understanding the impact of different batch sizes on embodied energy per product.

This would provide them with an overview of the energy used to manufacture the product as a result of design decisions (i.e. the impact of designing a product to be made from injection moulded plastic instead of turned wood).

Engineers can also use the model to assess the energy consumed by a specific process route and can then compare it to alternative process routes to determine better energy efficiency. Production planners too can assess energy requirements of various production plans to minimise energy consumption through examining the energy use for each schedule.

The simulation software is able to read a range of energy information, and the outputs can be tailored to provide a range of analyses for different users. The domain requirements for each type of user, the possible analyses and outputs are summarised in Table 9.1. below. The model developed as part of the research is designed to evaluate the energy consumption required by the particular process chain base on the product features. In addition, it also tests the impact of varying production time (as a result of delays and queues) on embodied product energy. Different batch sizes can also be varied to evaluate the impact of varying batch sizes on production time and therefore the embodied product energy of the manufactured part.

User Type	Data requirements and inputs	Analysis and Outputs
Designer	Design features and the respective processes , material type .	Energy requirement for each design feature.
Engineer	Details of processes, material type, energy data related to the resources that carry out the processes, data from the manufacturing plant.	Energy requirement to manufacture the product using the set processes and the efficiency of the processes.
Operator	Energy consumption at different operational modes and configurations.	The impact of setup changes and processing parameter changes on the energy requirement of the resources.
Production Planner	Schedules of the jobs and the processing times for each batch of product.	Optimal schedule for maximum energy efficiency.
Energy Manager	Energy data for processing equipment and the facility	Overall energy consumption of a facility and energy breakdown for an area or product.

Table 9.1: Various domain requirements for the energy model for various users.

9.3 Software Implementation for Energy Simulation Model

A simulation software package called Arena™ developed by Rockwell Automation (2011) has been utilised to design and implement the energy simulation model. Arena is widely used in both industry and academia. It is a general purpose, discrete event simulation software and utilises a graphical interface to simplify the model development. The model logic is generated through the selection of functional modules from the Project bar and placing them within the working area to represent the system that is being modelled. The range of functional modules include – “create”, “assign”, “dispose” etc. which when placed in the right order enable the flow of products through the process to be modelled. Further descriptions of these modules are described in the Appendix 2. Figure 9.3 provides an overview of the main working window in Arena and highlights the various modules and shows how they can be placed to represent a production system.

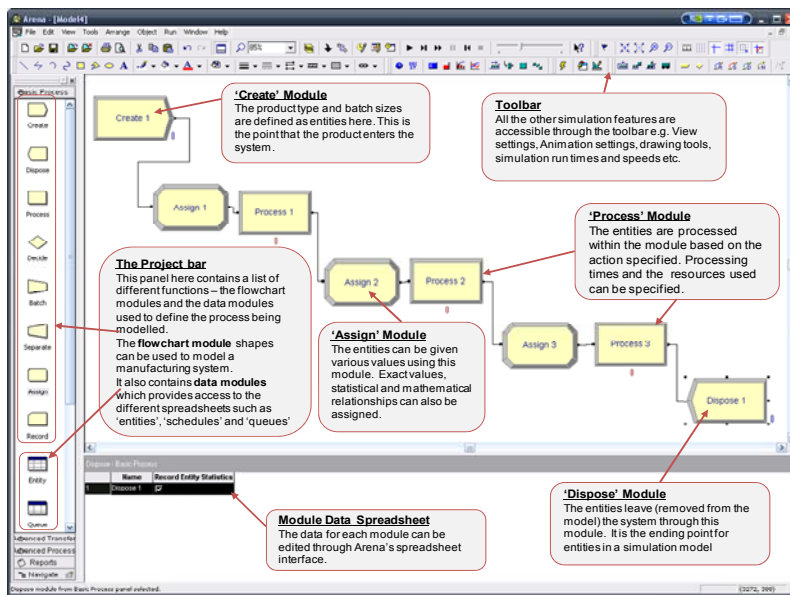

Figure 9.3: Overview of simulation window in Arena showing the different modelling modules and features

9.4 Implementation of DE and IE within the ESM

There are primarily two major tasks involved in the implementation of DE and IE within the energy simulation model, as outlined below and explained in the following sections.

- i. Definition of the energy data required by the model
- ii. Representation of DE and IE calculations with the model

9.4.1 Definition of Energy Data within the Model.

Typically a wide range of data may be required for developing a simulation model. The range and amount of data is entirely dependent on the complexity of the manufacturing system and the processes being modelled. The data can be entered manually by user or automatically imported through spreadsheets. To allocate the data to products passing through the system, the 'Assign' module is used to tag data to an entity representing the product. Furthermore, the energy data is tagged to the products as "attributes" which is a specific value that can differ from one entity to another. Attributes can be defined and values can be assigned by the user. If the TE and the AE are already known for the particular product, the values can be entered directly as shown in Figure 9.4.

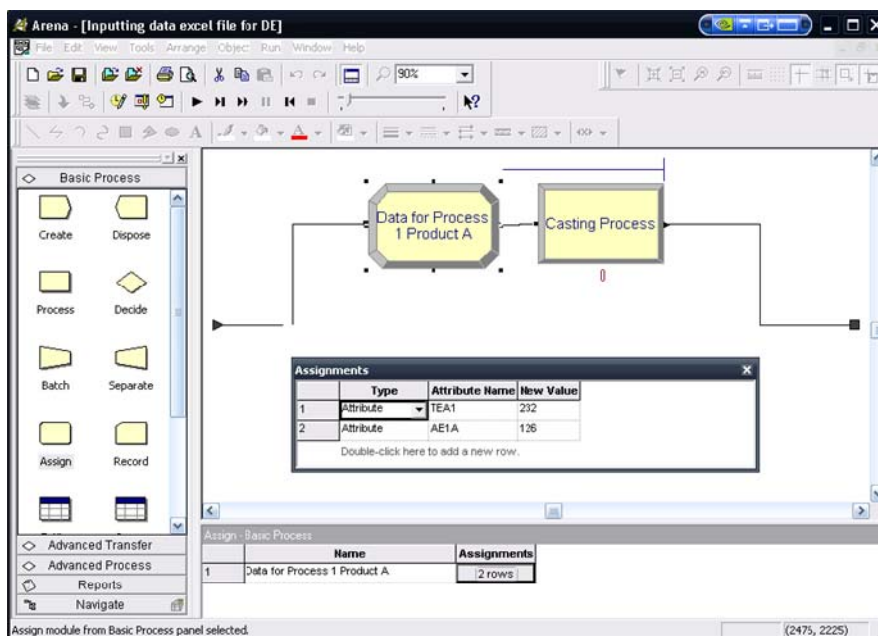

Figure 9.4: Entering data directly into the model through the use of the 'Assign' Module

In cases where there is a huge volume of data, it is possible to use Microsoft Excel to tabulate the TE and AE data for the processes and the products so that the data can be easily imported from databases or managed in a centralised document. Figure 9.5 shows a screen print of the 'Read' data module and the respective excel file with the energy data to be imported.

The use of the 'Read' module reduces the need to input the energy data into individual 'Assign' modules but allows the user to store the data in a single file which can be linked to the other 'Process' modules in the simulation model. In addition, since a majority of data loggers use Excel file formats to store data, the use of Excel provides compatibility between Arena and these data loggers and simplifies the data transfer process, especially in cases where large volumes of data are involved.

A similar module called the 'Write' module can export the data to an Excel file. This can be useful as the graphic generation capabilities in Arena are limited. In Excel complex charts and data formatting can be used to present the results in a clear and concise manner, as will be demonstrated in Section 9.5. The export of data to Excel provides greater flexibility for further data analysis due to Excel's versatility in data processing.

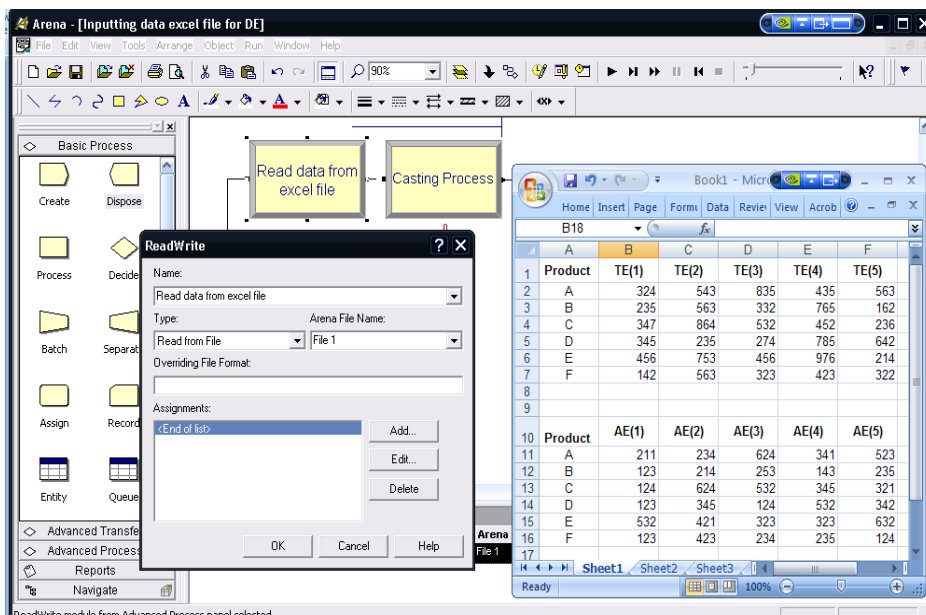

Figure 9.5: Using MS Excel to store the data and exporting the data into Arena

9.4.2 Representation of DE and IE calculations within the model

As outlined in Chapter 8, in applications where empirical data is unavailable, DE can be established through mathematical models which can also be represented within the ESM. The equations used to calculate the energy consumption of the product at each process is defined through the ‘Variable’ module in Arena. A ‘Variable’ is an element of information that reflects the characteristic of the system. In contrast to attributes, variables are not tied to any entities (i.e. Products) but applied at the system level. The variables are accessible by entities and can be changed by any entity. The data input for the variable can be specified using ‘Attributes’ and the equation is then built in a separate ‘Assign’ module in the form of an expression.

In this chapter, the example of a casting process is used to describe the representation of IE and DE calculations. For example, to establish the TE of casting, the following data is required: mass of the product (m), the latent heat of fusion (L), the specific heat capacity (C), melting temperature (T_m) and the room temperature (T). All these can be specified within the ‘Assign’ module as attributes with a specific value as shown in Figure 9.6. To calculate the energy consumed by a casting process, Equation 9.1 [$mL + mC(T_m - T)$] included in Table 9.2, is used to correlate the attributes to a variable which calculates the energy consumed for the process for one entity. Table 9.2 also shows the equation used to establish the TE of a Casting process and Equation 9.2 is the expression of this equation in the Arena model.

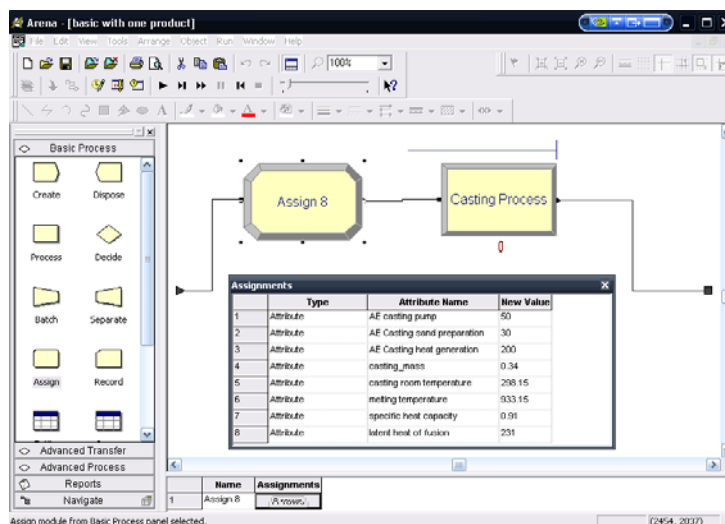

Figure 9.6: Data on the casting process is entered in the model through the ‘Assign’ module as attributes

Process 1: Casting	Theoretical Energy
Actual equation	$mL + mC(T_m - T)$ [Equation 9.1]
	Key: m = mass (kg) T = room temperature (K) C = specific heat capacity (kJ/(Kg.K)) L = latent heat of fusion (kJ/kg) T _m = Melting temperature (K)
Equation defined in the model	casting_mass * latent heat of fusion + casting_mass * specific heat capacity * (melting temperature - casting room temperature) [Equation 9.2]
	Key: casting_mass = mass (kg) casting_room_temperature = room temperature (K) specific heat capacity = specific heat capacity (kJ/(Kg.K)) latent heat of fusion = latent heat of fusion (kJ/kg) melting temperature = Melting temperature (K)

Table 9.2: Actual equation used to establish TE compared with the equivalent used in the simulation

The equations relating to the AE of the process are defined in the same manner. For example in a casting process, the AE is derived from the losses through heat generation, sand preparation, as well as the operation of the hydraulic system to lift and pour the molten metal. The values for each of these are first defined as attributes and then correlated through the variable which sums the individual components of AE. The equation for AE for casting is shown in Table 9.3, and denoted by Equation 9.3. The ‘Variable’ modules within the Arena model representing the equation of TE and AE for the casting process is shown in Figure 9.7.

Process 1: Casting	Auxiliary Energy
Equation defined in the model	AE Casting heat generation + AE Casting pump + AE Casting sand preparation [Equation 9.3]
	Key: AE Casting heat generation = energy losses through heat generation (kJ) AE Casting pump = energy required for the pumping of hydraulic fluid (kJ) AE Casting sand preparation = energy required to prepare the sand for the mould for casting (kJ)

Table 9.3: The expression used in the ‘Assign’ module to represent the sum of the various AE of the casting process

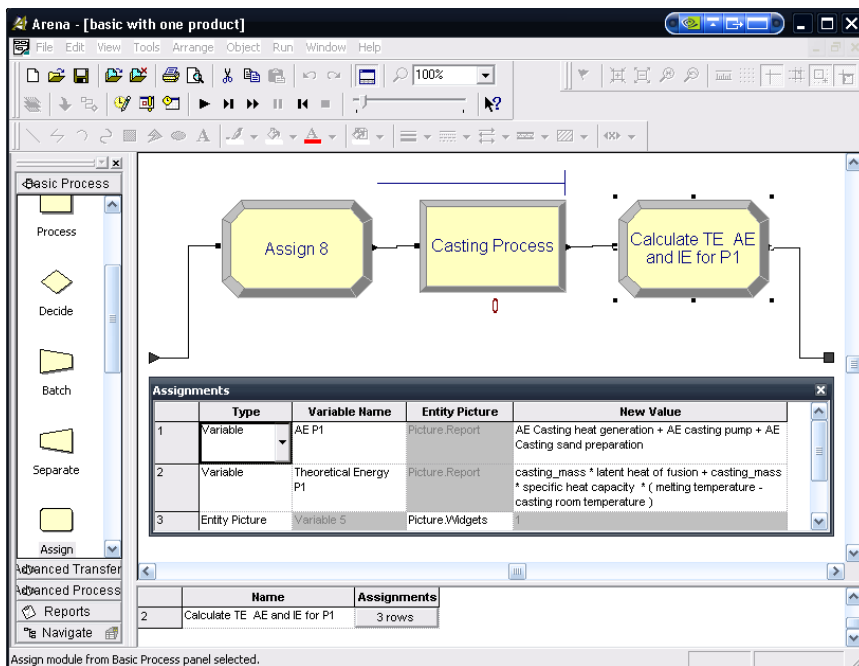

Figure 9.7: Calculating the TE and AE for the casting process using the 'Assign' module to specify an equation

Similarly, as detailed in Chapter 8, the IE of a manufacturing zone is a function of the throughput of that zone. As such, the duration in which a product spends in a process can be used to determine the throughput and consequently the IE that can be attributed to the single part.

The actual duration which a product spends in the process can be defined within the 'Process' module in Arena. The cycle time for the process for the particular product can be defined as a constant singular value or can be defined as a mathematical or statistical expression (see Figure 9.8). To illustrate the possibility of modelling statistical relationships, the duration of the casting process has been modelled based on a normal distribution. Other statistical relationships can be expressed in the software and the appropriate relationship can be used as and when they are defined based on specific requirements. For example, if the cycle time, CT, is not constant but varies according to a normal distribution, then it can be expressed as Equation 9.4 –

$$\text{NORM}(\text{Mean}, \text{StdDev}) \quad [\text{Equation 9.4}]$$

Where,

NORM indicates a Normal distribution

Mean is the mean value of the cycle time for the process

StdDev is the standard deviation for the cycle time for the process.

In a similar manner the start time, the processing time and the queuing time for a process in the ESM are represented using a number of appropriate attributes that can be assigned to various entities. For example, the simulation model is able to assign an attribute ‘Start Time’ as the product enters the process which is the current simulation time denoted as ‘TNOW’. ‘TNOW’ is a time stamp that the software gives each entity when it enters or leaves an event, (see Figure 9.9). Using these time attributes for an entity, the IE for a product can be established using the Equation 9.5 as outlined in Chapter 8. The expression used in Arena to represent the calculation for IE is shown in Table 9.4 and denoted as Equation 9.6.

Process 1: Casting	Indirect Energy
Actual equation	$IE_{zone(m)A} = IE_{zone(m)} / TP_{zone(m)A} \quad [\text{Equation 9.5}]$
	Key: $IE_{zone(m)A}$ is the indirect energy attributed to Product <i>A</i> in zone <i>m</i> $IE_{zone(m)}$ is the indirect energy consumed by zone <i>m</i> per hour $TP_{zone(m)A}$ is the throughput of Product <i>A</i> per hour in zone <i>m</i>
Model equivalent	$IE_{zone(m)A} = IE_{zone(m)} / (60 / (\text{TNOW} - \text{arrive time in casting})) \quad [\text{Equation 9.6}]$
	Key: $IE_{zone(m)A}$ = indirect energy attributed to Product <i>A</i> in zone <i>m</i> $IE_{zone(m)}$ = Indirect energy consumed by zone <i>m</i> per hour TNOW = time when entity leaves the process Arrive time in casting = time when the entity arrives at the process

Table 9.4: The equation used in the framework and the equivalent expression used to represent the IE in the simulation model

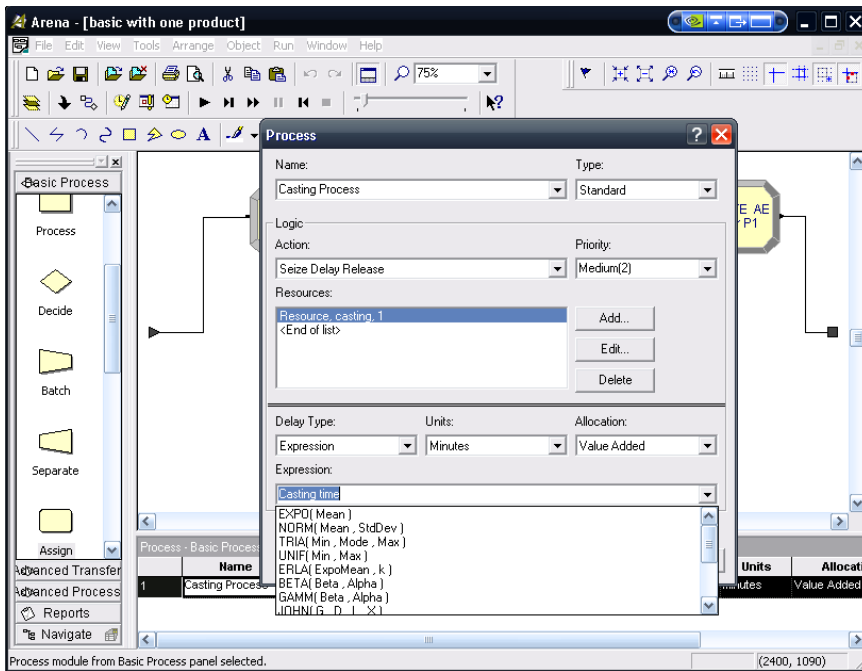

Figure 9.8: Specifying the process time within the 'Process' module. The process time can be expressed as a constant value or as a statistical or mathematical expression.

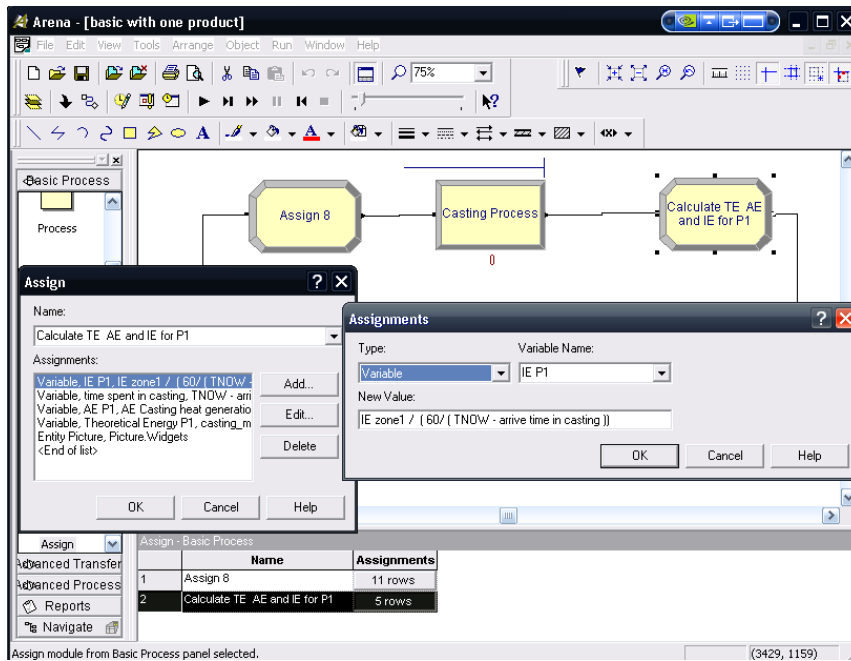

Figure 9.9: The Assign module can be used to denote the IE equation which records the time a product spends in a process

In this chapter a batch of one has been used to describe the model. As described in Section 9.2, the effect of multiple product types and impact of larger batches can be explored within the model.

The create module provides the flexibility of adjusting the number of batches that are being manufactured as well as the size of the batch. As shown in Figure 9.10, the batching details can be specified through the 'Create' module. The model works out any queue times or delay times and records the time so that each entity has its unique log of processing times and wait times.

As the indirect energy and auxiliary energy consumption are represented as a function of time, the energy consumed by each entity can be established by the model depending on the time it takes the entity to pass through the processes.

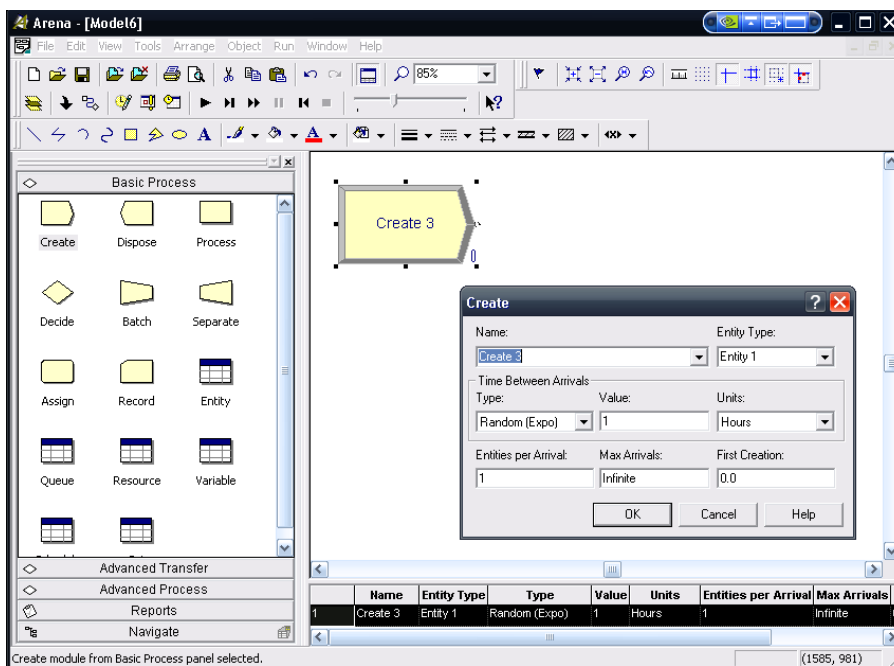

Figure 9.10: Using the create module to set the number of batches as well as different batch sizes.

9.5 Output from the Simulation Model

Once the relevant parameters have been assigned to the processes they can be brought together to generate data. There are three main outputs incorporated in the ESM model as outlined below and described in the remaining sections of this chapter:

1. The Real Time Data related to Process Flow
2. The Embodied Product Energy Data
3. The Energy Graphs

9.5.1 The Real Time Data related to Process Flow

In the simulation model the process flow is represented through the flow diagrams which can be animated during the simulation run. An example of a process flow for the manufacture of an elbow pipe with three processes, namely Casting, Grinding and Inspection is shown in Figure 9.9. In order to maintain simplicity and clarity a hierarchal modelling approach has been adopted. The three processes of casting, grinding, inspection have been modelled individually and each process has been further defined using a 'Sub model'. The sub model allows the main model to display high level information and allows for greater detail to be included in a separate modelling window. Figure 9.10 shows the three sub models for casting, grinding and inspection processes. The use of the sub models enables complex processes that require multiple activities to be decomposed into smaller blocks and also ensures that the correct information for that process is included. This also eliminates any confusion between the data requirement for different processes. As can be seen in Figure 9.10, the data specification for each process can be fairly substantial, the sub models allow each process to be handled and managed individually and thus if there are changes to the operational parameters, it would be easier to locate and edit the data within the appropriate model or submodel.

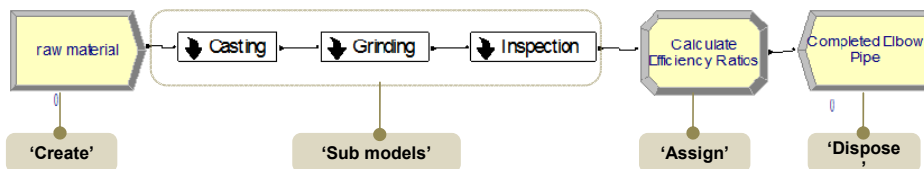

Figure 9.11: Process flow created for the Elbow pipe using the four main Arena modules

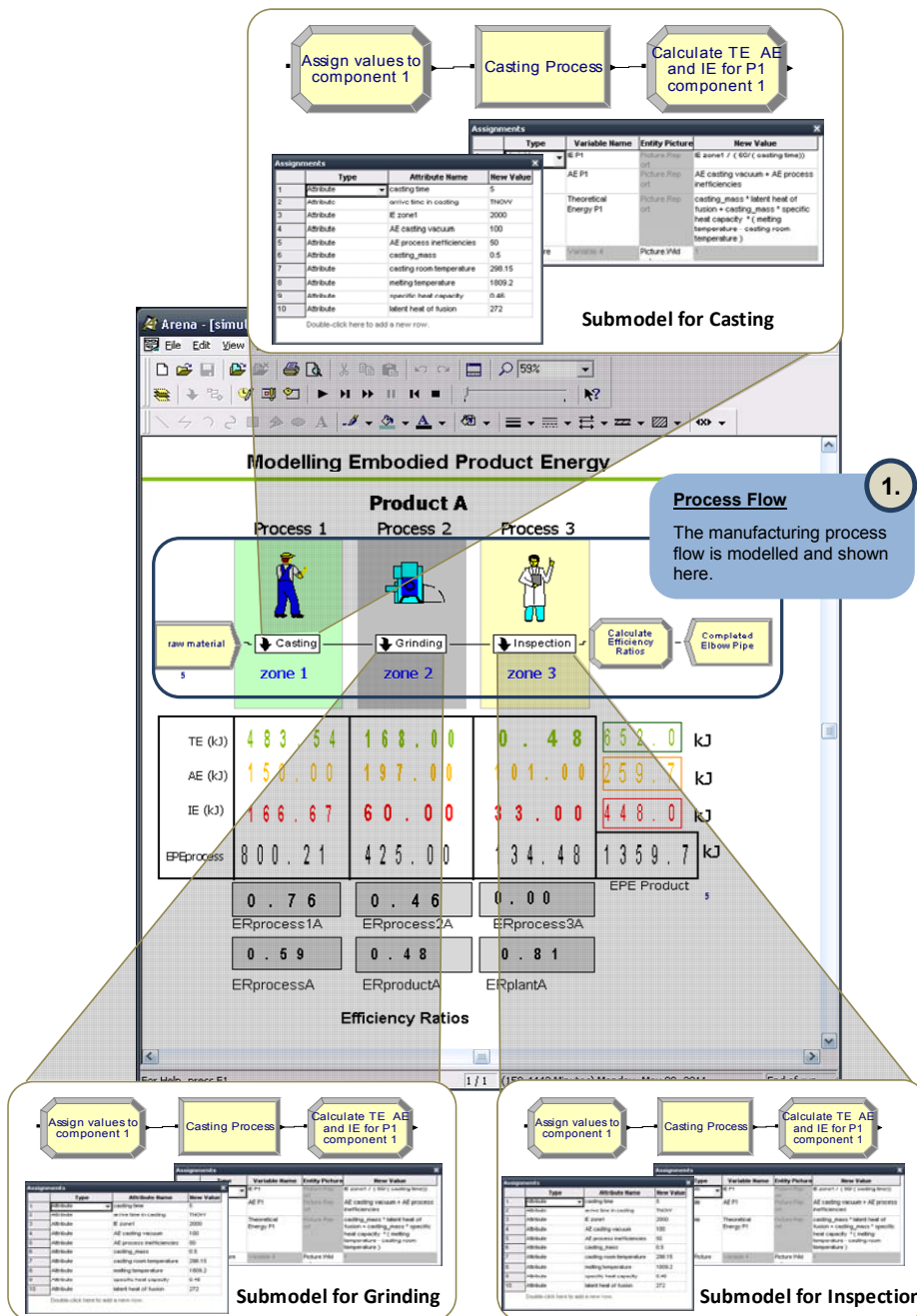

Figure 9.12: The simulation model for the elbow pipe showing the top level simulation window along with the sub model windows with the data input and calculations for each process

9.5.2 The Embodied Product Energy Data

The second output is the energy data that can be calculated through the modelling engine. The energy values for TE, AE and IE which were previously defined as 'Variables' are stored and displayed within the modelling window. In addition to providing an overall EPE output, the data for each energy component has been broken down so that the TE, AE and IE values for each process can be represented. The efficiency ratios are also displayed here as shown in Figure 9.11. During a simulation run, the energy data for each entity (i.e. product) varies depending on the mathematical relationships or statistical distributions that have been specified. For an overview of the energy consumed by all entities the data has to be exported and charted in Excel as described in the next section.

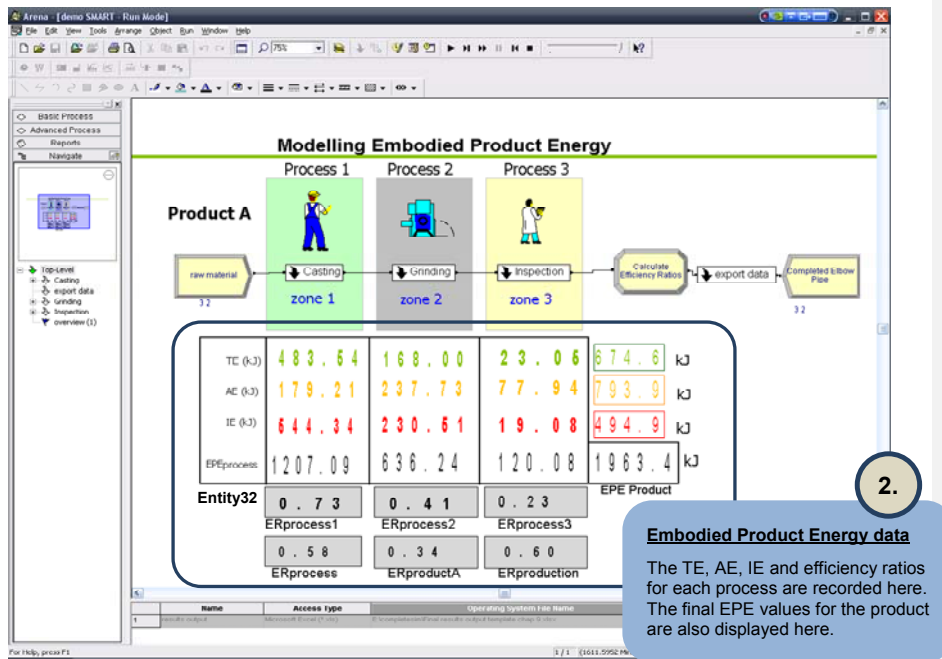

Figure 9.13: The output of the simulation model, the values for TE, AE and IE are displayed alongside the efficiency ratios

9.5.3 The Energy Graphs

There are 5 different charts created from the data that has been exported to Excel from the ESM. These are:

- a) Process Energy Charts
- b) Breakdown of average EPE by Process
- c) Numerical Display of EPE and Energy Efficiency Ratios
- d) Column Chart of overall EPE for the Product
- e) Column Charts of Energy Efficiency Ratio

An example of a process energy chart is provided in Figure 9.12 which represents the breakdown of average values of TE, AE and IE for various parts for Process 1. In this figure the black line on the chart represents the EPE value for each entity in Process 1 which has been plotted on the primary axis and the colour lines are used to represent the TE (green), AE (yellow) and IE (red) plotted using the secondary axis. Finally, the column chart in Figure 9.12 provides breakdown denoted by the respective colours. Both the line chart and column chart is shown in Figure 9.14a.

The average EPE of each process for Product A is also displayed in a column chart with the breakdown of the energy components displayed as the series as indicated by the green (TE), yellow (AE) and red (IE), see Figure 9.13. The ER_{process} , which denotes the efficiency of the process, is also plotted within the same graph on the secondary axis so the efficiency of the process can be compared against the energy intensity of the process.

The average EPE value and the Energy Efficiency Ratios for Product A are displayed numerically as shown in Figure 9.14c. The average EPE value has also been plotted in a column chart with the process displayed as series within the column, see Figure 9.14d. The three efficiency ratios are also displayed in a column chart as indicated in Figure 9.14e.

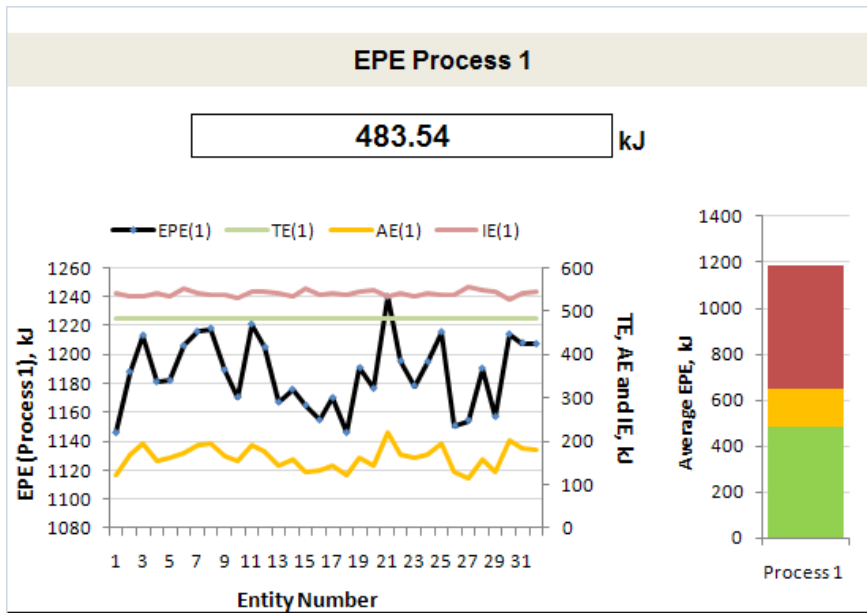

Figure 9.14: An example of the process energy chart showing plot of TE, AE and IE for each entity in Process 1. Numerical value at the top indicates the average energy consumed

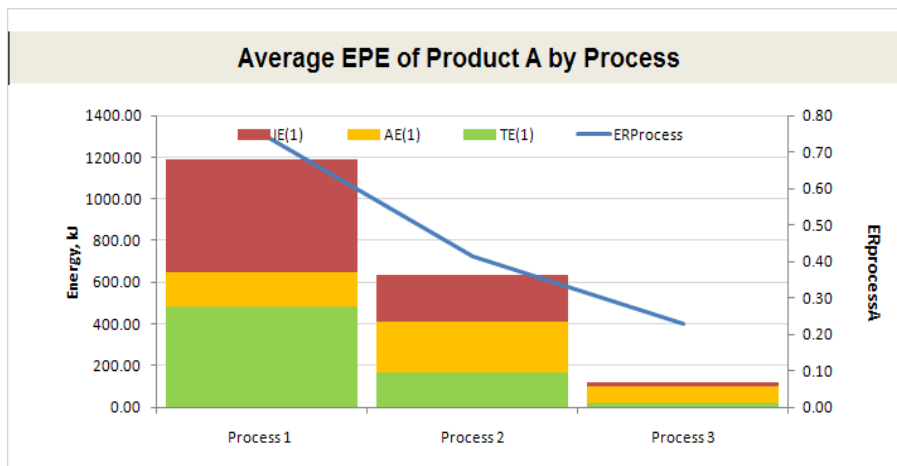

Figure 9.15: Chart showing average embodied energy by process. $ER_{process}$ for each process are plotted on the secondary axis

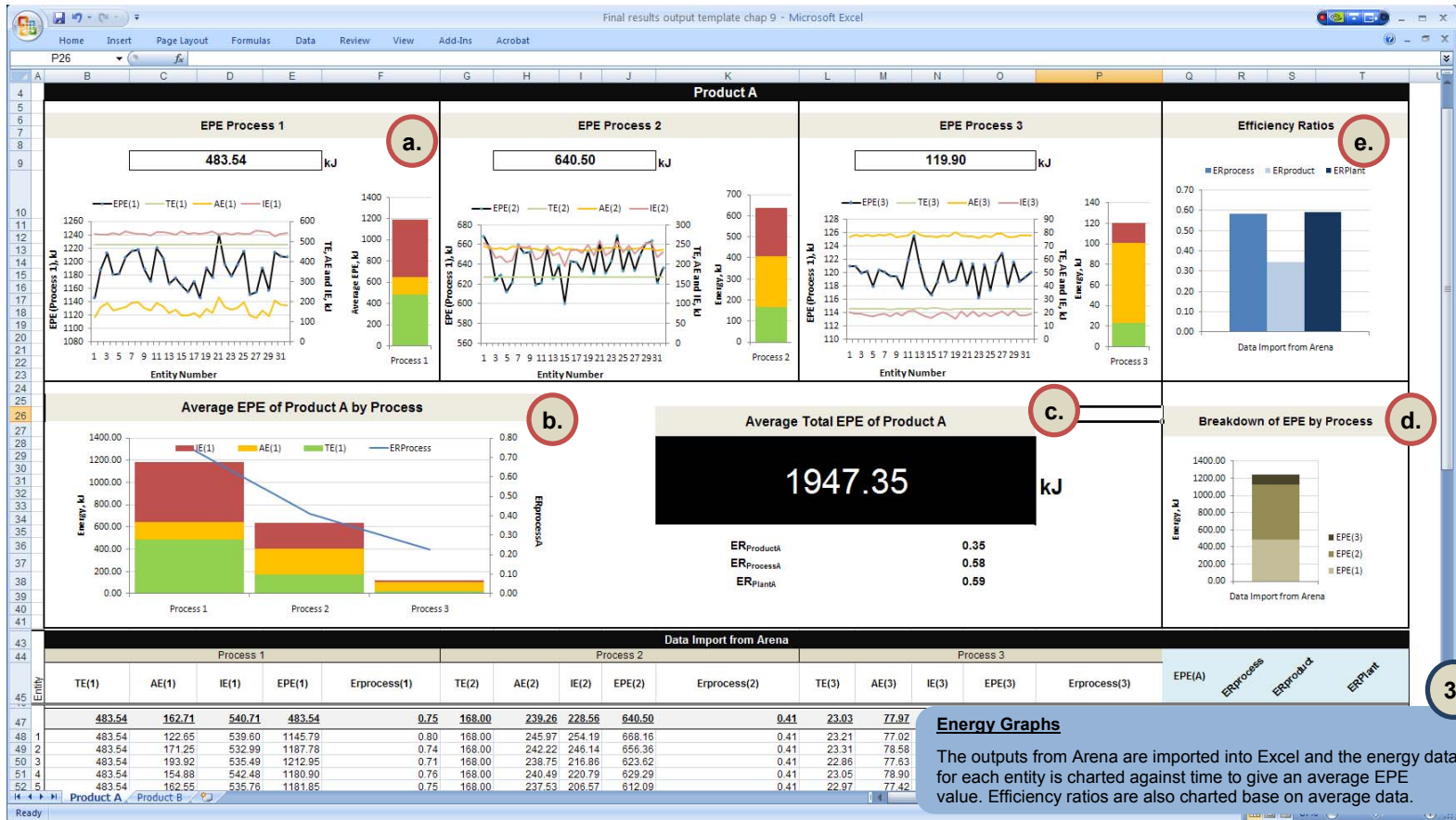

Figure 9.16: Overview of the energy graphs in Excel a) Process Energy Charts, b) Efficiency Ratio Charts, c) Chart of EPE for each product over time, d) Average EPE and ER ratios for the product, e) Average EPE and ER ratio per process, f) Breakdown on EPE by Process.

9.6 Chapter Summary

This chapter has described the design and implementation of the energy simulation model and its outputs. It has also shown that use of a simulation tool can provide greater modelling flexibility and greater transparency into energy consumption within manufacturing systems. The simulation model is built through creating a process flow using flowchart type modules in which product and manufacturing data is assigned. The embodied energy is attributed to the product as it moves through the system and the data can be exported to Excel where it is presented graphically.

The research foresees two uses of this software i) the exploration of “what if” scenarios to see how changes in process and production operation can impact energy consumption and ii) using the breakdown of energy flows and the modelling outputs as a supporting tool to improve product design.

The understanding of how different batch sizing or production scheduling may impact energy consumption can aid production planners and engineers in the day to day operation of the plant and provide insights for future production planning. In addition, the breakdown of energy consumption provided by the simulation can not only be used to support decisions for operational improvements but also upstream processes like design, as illustrated in Figure 9.15. The application of the energy simulation model to support the design process will be described in Chapter 10. In chapter 11 a case study is used to illustrate the applicability of the model to support both system and product design.

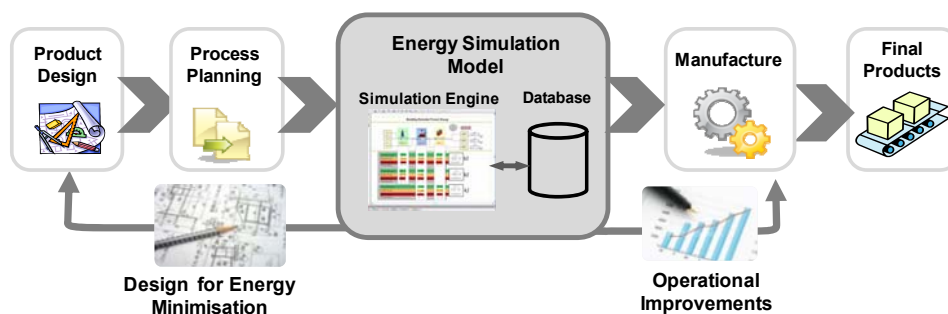

Figure 9.17: The application of energy simulation model to aid operational improvements and product design

Chapter 10 A Design for Energy Minimisation Methodology

10.1 Introduction

This chapter discusses the use of the EPE framework to improve the design process of a product. A new design methodology, which aims to minimise the energy consumption during the production phase of a product, termed Design for Energy Minimisation (DfEM), is proposed in this chapter. In order to be able to define the context and scope for DfEM, there is a need to understand the existing design processes and other relevant 'Design for X' (DFX) approaches. Therefore the chapter begins with a brief overview of existing design processes and the evolution of DFX, before outlining the details of the DfEM and its application within centralised and distributed design applications.

10.2 Overview of Design for Energy Minimisation

Design plays a significant role in determining the environmental impact of a product, as much as 70% of the environmental damage of a product is established at the start of the design activity (Rebitzer, 2002) as shown in Figure 10.1. The energy simulation model as discussed in Chapter 9 can be used to improve both the design of products and the operation of manufacturing systems. So as to understand the applicability of the energy simulation model to the design process, the context for the design process and DfEM methodology will first be discussed in the next few sections.

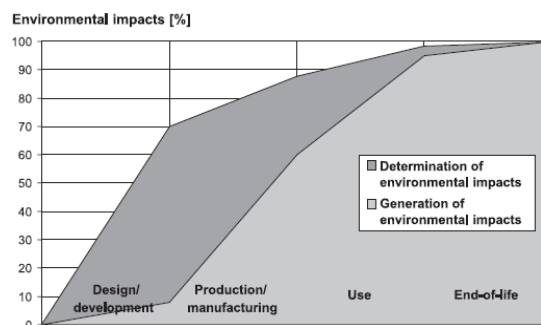

Figure 10.1: The determination and generation of environmental impacts in a product's life cycle (Rebitzer, 2002)

10.3 An Overview of the Existing Design Process

The design process involves a sequence of activities to enable a concept or an idea to develop into a detailed solution. The related activities are grouped together where certain decisions are made at the end of that stage and the level of detail and finality of the design increases with each subsequent stage. There are many different design models that can be applied depending on the nature of the product and the scope of the product development. A common design model, and the one adopted by this research, is by Pugh (1991) which consists of three generic design stages: 1) Conceptual Design, 2) Detail Design and 3) Manufacture as shown in Figure 10.2.

Once the product design specification has been established, the aim of the conceptual design stage is to generate ideas by searching for essential problems, combining working principles and selecting a suitable concept. The second stage is detail design which develops the concept chosen at the previous stage into a more concrete proposal with specifications of geometry, materials and tolerances of all parts of the product. Production costs and robust performance are the main concern at this stage. Finally the focus of the third stage, manufacture, is to minimize the component and assembly cost.

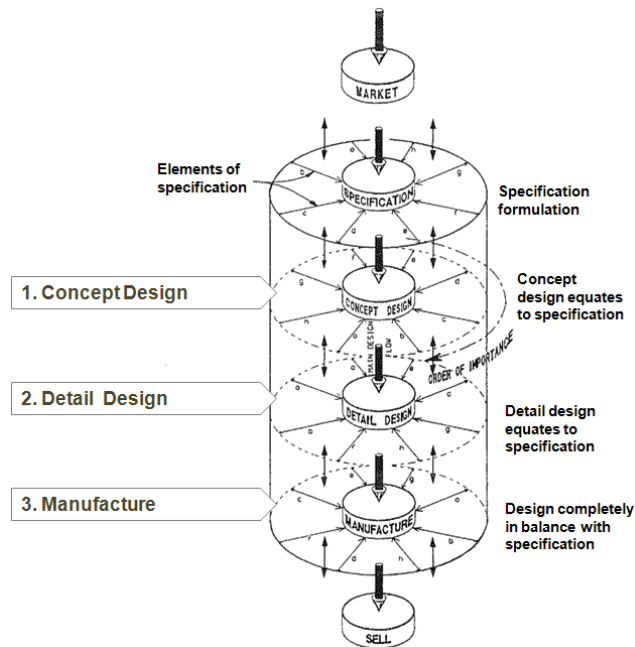

Figure 10.2: The three main design stages - concept design, detail design and manufacture as proposed by Pugh (1991)

10.4 Evolution of Design for X

Traditionally design methods were focused on form and function. With the industrial revolution and the start of mass production, products were initially designed for producibility. Subsequently, the focus of design methods expanded to include quality (Taguchi, 1986), safety (Hammer, 1980) and assembly (Boothroyd and Dewhurst, 1983). The development of the Design for Assembly (DfA) methodology sparked a proliferation of various analytical techniques that guide designers towards integrating various issues into product design, marking the start of design methodologies that came to be known as 'Design for X' (Govil and Magrab, 2000). One such method, namely 'Design for Manufacturing' (DfM) led to enormous benefits such as the simplification of products, reduction of assembly and manufacturing costs, improvement of quality, and reduction of time to market (Kuo, 2001). More recently with the increasing concern about climate change and the environmental impact of products, a new design strategy, referred to as 'Design for the Environment' (DfE) has been developed to minimise environmental impacts (Lewis *et al.*, 2001).

As design decisions greatly influence the overall environmental impact of a product environmental considerations should be integrated as early as possible in the design phase (Duflou and Dewulf, 2004). As part of the DfE approach, a range of environmental issues (e.g. resource consumption, end-of-life disposal, waste management, recyclability reusability, use of toxic and hazardous material, etc.) associated with a product are to be considered at the design stage. As DfE covers a wide scope, specific tools such as Design for Disassembly, Design for Recycling, Design for Remanufacture and Design for End-of-Life that focus on a particular life cycle phase or environmental aspect have also been developed. However as far as this research could establish, there has yet to be an agreed approach for the systematic consideration of energy minimisation across a product life cycle. Therefore this research proposes a novel Design for Energy Minimisation (DfEM) approach that is integrated with the different design stages that can be applied across the life cycle phases and compliments the other tools within the DfE family. An overview of the DfE tools, including DfEM, and their relation to the tool development timeline is shown in Figure 10.3. The DfEM approach presented in this research is detailed in the next section.

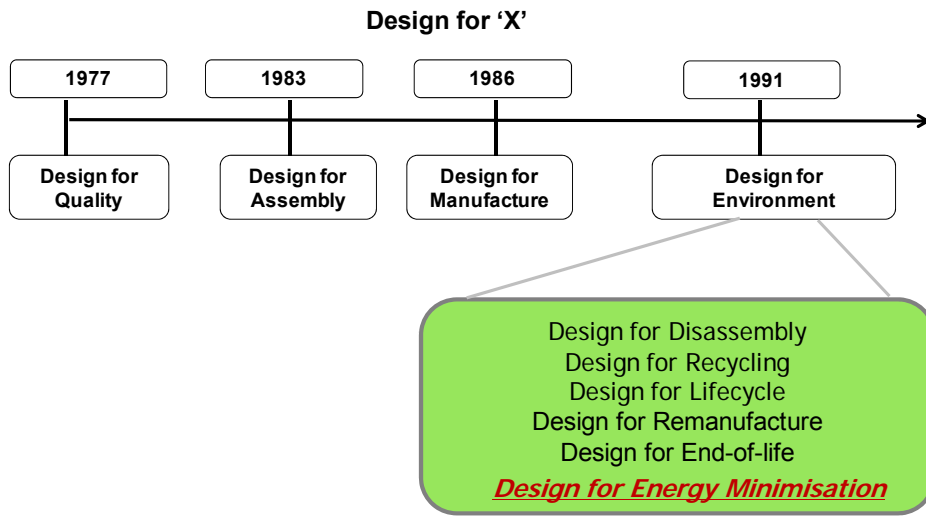

Figure 10.3: The evolution of design tools over time

10.5 Life Cycle Approach to DfEM and Integration with the Design Process

To consider the energy minimisation over a product's life cycle, a wide range of energy use including material, manufacturing, use and end-of-life needs to be investigated. For energy consuming products (i.e. electronic products, cars, lights etc.) the 'use' phase would probably be important, however for many other non-energy consuming products (such as furniture and packaging), the production phase may represent a significant proportion of energy consumption over its life cycle. In addition the scope of issues to be considered is also wide ranging i.e. the type of material used, the processes used, the functionality of the product and how the product is transported all have energy implications and thus unlike the other DfX tools such as Design for Disassembly or Design for Recycling, DfEM needs to be considered at every phase of a product's life cycle.

The importance of energy considerations during the design process has been recognised within the DfE approach, however as far as this research has been able to establish, there has been a limited number of systematic and comprehensive approaches that can be integrated within the whole design process for reducing energy consumption over the product life cycle. The few DfE tools that consider energy consumption are often

qualitative and highly subjective, with the effectiveness of the tool often dependant on the experience of the designer. Those that are quantitative based are highly complex models and require information that is usually unavailable at the initial design stages as the product details and specifications have yet to be established and are therefore unknown. In addition these tools have also gained little acceptance as they are not well integrated within the design process.

The DfEM presented in this research is based on a three stage design process consisting of concept design, detail design and manufacture as identified by Pugh (1991) and is commonly used within the design community (see Figure 10.4). In addition, the DfEM methodology should encompass the entire product life cycle so that energy minimisation is considered at every phase of the life cycle and to support a cradle to grave approach as shown in Figure 10.4. In practice, the combination of this three stage design process and a life cycle design approach necessitates the ability to provide support for design decisions at various levels of complexity as indicated in Figure 10.4. For example, in the conceptual design there may be a requirement for only a quick and simple assessment to highlight the impact of selection of various materials and processes. Whereas in detail design, there will be a need for much more comprehensive support in the form of predicting the environmental impact for various process chains/groups. Similarly, in a manufacturing stage there is a need for different support based on energy data collection, monitoring, auditing and assessment. A set of appropriate tools to support these varying requirements is described in the next section.

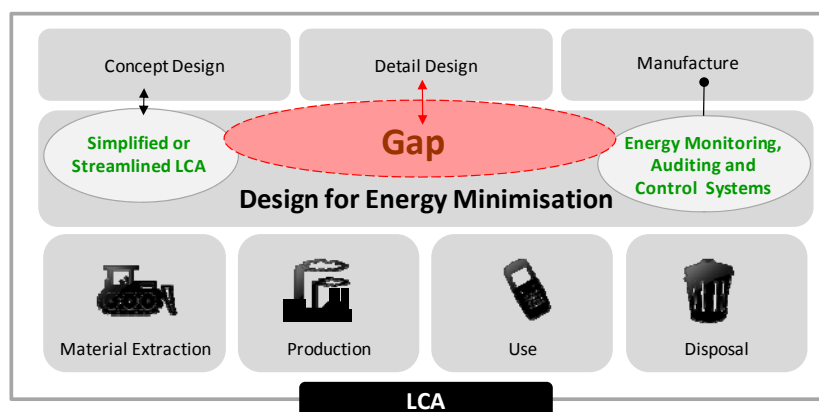

Figure 10.4: DfEM considerations across the life cycle phases and design phases

10.6 Tools to support DfEM in Manufacturing

As outlined in Chapter 6, the scope of this research is limited to the production phase of a product life cycle. Therefore in this thesis, only the tools that provide the assessment of energy consumption within the production phase are considered.

In this context, to support the different requirements within the design process, there are three main categories of tools that have been proposed within this research, these are 1) Streamlined Life Cycle Assessments (S-LCA) in the Concept Design phase, 2) Energy Simulation Models (ESM) during the detail design phase and 3) Advance Energy Metering Systems (AEMS) in the production phase as illustrated in Figure 10.5. These tools will be described further in the following sections.

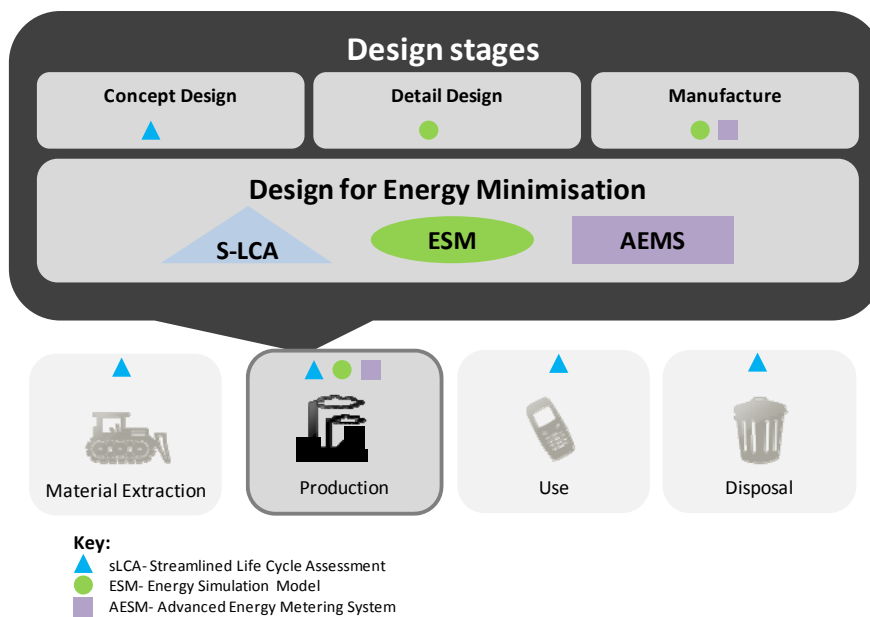

Figure 10.5: DfEM tools for the production phase

10.6.1 Streamlined Life Cycle Assessment

Typically a LCA is used to evaluate the environmental impact of a product which includes the energy consumption during production. However for a product that does not yet exist it is unrealistic for a designer to have access to all the specific information about the materials and processes required for a comprehensive LCA at the early stages of product design. The analysis of different categories of environmental impact in relation to life cycle phases can help designers formulate the best opportunities for implementing these aspects into product planning (O'Shea, 2002).

In order to minimize the complexity and time taken to conduct a full LCA, streamlined models and additional assumptions have been used to reduce the evaluation effort in traditional LCA. These condensed LCA are known as streamlined LCA (S-LCA) which encompasses a group of approaches designed to simplify and reduce the time, cost and effort involved in conducting a full LCA while still facilitating accurate and effective decisions. Duflou *et al.* (2002) have developed an Eco-PaS tool which can be applied in the early stage of the design process by estimating the environmental impact of a product based on functional requirements rather than technical parameters (which are often unavailable at the early design stage) needed by typical LCA applications.

Additionally, Granta Design (2010) has developed a streamlined LCA tool called the Eco Audit tool (part of the Cambridge Engineering Selector (CES) suite of software) which uses information about product composition, processing, usage, transportation, and disposal. The tool then combines this with eco property data on the materials and processes used in the design to calculate the energy usage and CO₂ output resulting from each stage in the product life cycle as shown in Figure 10.6. This high level overview is particularly useful during the first stage of product design (i.e. concept design) which can guide the design strategy by identifying materials and processes that fulfil the functional requirements at a minimal energy cost for the product. Birch *et al.* (2011) found the CES materials and processes database to be an excellent base for greater automation to aid the designer by suggesting alternative materials and processes at the design stage. According to Giudice *et al.* (2005), the integration of environmental aspects upstream of the design process will provide the versatility necessary for intervention and improvement of products during their development.

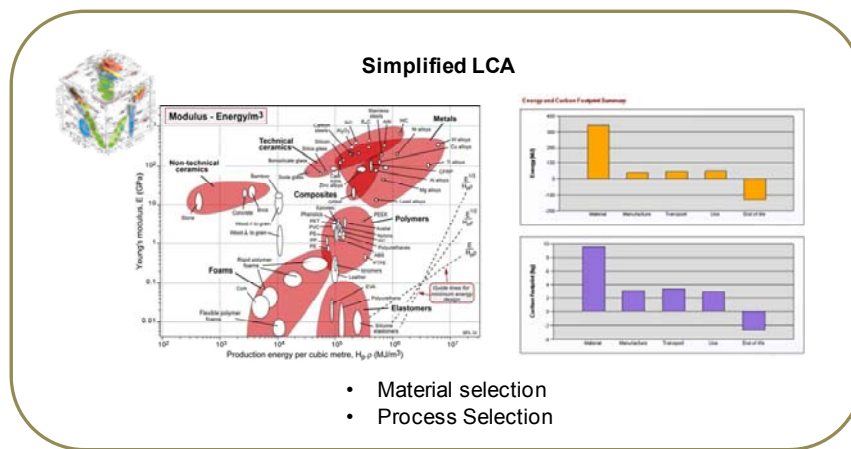

Figure 10.6: Streamlined Life Cycle Assessment can be conducted through the use of software such as CES EcoSelector

10.6.2 Energy Simulation Model

For the detail design phase of the design process, a greater level of detail is available in terms of the design specifications such as part features, dimensions and finishing. This information would provide an indication of the manufacturing parameters that were required to achieve the design specifications. The energy consumed during the production phase can be estimated with greater accuracy at this stage. It is therefore proposed that an Energy Simulation Model (ESM) can be used to evaluate the embodied energy of the products by modelling energy flows within the production phase of a product life cycle. The ESM would aid the decision making in process parameter selection, machine selection as well as facility services selection. The ESM would also bridge the gap between high level streamlined LCA tools used at conceptual design and those used to monitor energy consumption as part of the manufacturing stage.

There are three main aspects to the ESM - the energy database, the simulation engine and a House of Quality (HOQ) based design support tool as shown in Figure 10.7. The energy database contains the characterisation of a range of processes. Detailed energy data for the processes can either be obtained from measurements within a production system or from established studies. The simulation approach reduces modelling efforts through pre existing process modules that can be applied to reflect the process chains required to manufacture the product for energy evaluations. The simulation engine is also highly flexible in the level of detail as well as the range of energy considerations to

be modelled. Energy parameters can be adjusted depending on needs and the systematic variation of these parameters can also support optimisation analysis and ‘what-if’ scenario planning.

The outputs of the simulation highlight energy hotspots that could provide the focus for energy improvements which can then be evaluated against design parameters using a HOQ based design support tool for improved product design. Details of the energy database, the simulation engine and the HOQ design support tool will be discussed in Section 10.7.3.

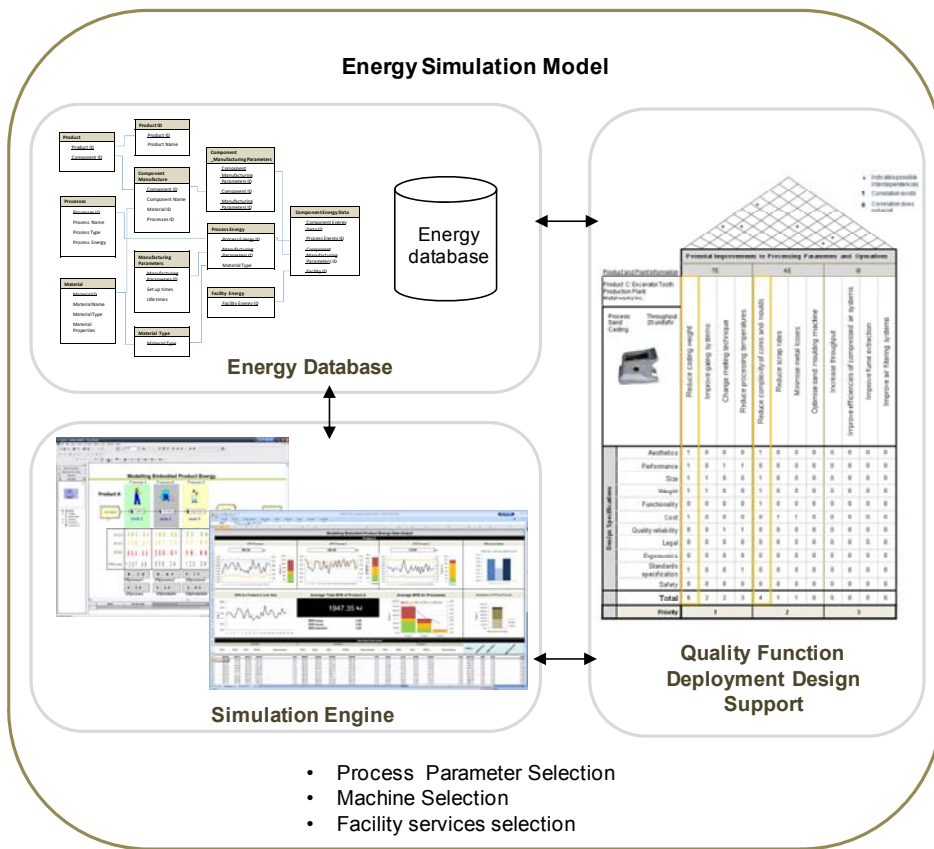

Figure 10.7: The Energy Simulation Model can help with process parameter selection, machine selection and facility services selection

10.6.3 Advanced Energy Metering System

The last stage of the design process is supported by Advanced Energy Metering Systems (AEMS) as shown in Figure 10.8. At this stage, the energy consumption within the manufacturing plant is the primary focus of the DfEM strategy. In order to gain an accurate picture of the energy consumption in manufacturing, energy management systems are used to track and measure the energy used in a production facility, providing a breakdown of energy consumption by various elements in a production system including both the buildings and production operations. An example of energy management software is Optima developed by Optima Energy Management (2010). It can track and monitor real time energy consumption, buys energy at best available prices and allows budgets and targets to be set for cost savings. Energy management systems depend on AEMS to provide energy data from various aspects of the manufacturing plant as well as data from external sources affecting energy use such as weather and building occupancy. AEMS provides support at the manufacturing stage through the monitoring and tracking of energy consumption at set time intervals, including real-time. Atypical consumption rates could indicate an incident or anomaly on the manufacturing line and could serve as an early warning system for production issues. The energy savings made through process and operational improvements as a result of changes to product design could be quantified through AEMS.

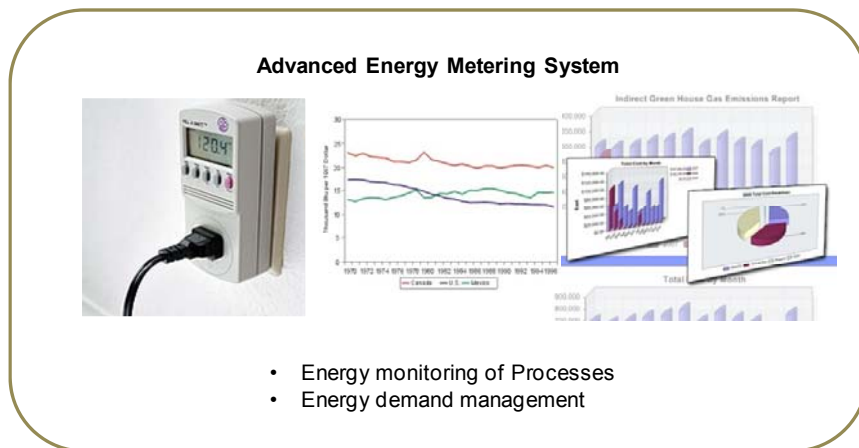

Figure 10.8: Advanced Energy Metering systems to track energy use of processes and equipment in a manufacturing facility

10.6.4 Integration of tools within the DfEM methodology

Each phase of the design process has its own requirements and focus thereby requiring a different set of tools (Pei, 2009). For example, creative based tools such as brainstorming and the morphological box are commonly used during the concept design phase whilst more analysis based tools such as Failure Mode and Effects Analysis (FMEA) and Value Analysis are often applied to evaluate and establish the feasibility and robustness of the ideas as well as to determine the most appropriate method of realising the product concept. Although these tools can be used independently within each phase of the design process, clearly greater benefits could be achieved through integration of these tools, as the data/knowledge generated by each can support the decisions made in other phases. This is especially true for the DfEM methodology. According to Giudice *et al.* (2006) the environmental objective to be achieved in product design (strategic product related, environmental objectives) can be summed up in two principal categories:

- Conservation of resources, recycling, energy recovery
- Prevention of pollution, waste and other impacts

These objectives can be achieved through an appropriate combination of design strategies some of which include: improvement of materials and energy efficiency; optimisation of functionality, avoidance of hazardous materials and energy efficiency, and, design for cleaner production and use. The data recorded by the AEMS can be used to support the ESM by providing more thorough and precise energy consumption values for the production facility and hence improving the accuracy of the simulation model. This in turn can improve material and process selection within CES by providing energy data sets relating to materials and processing that are customised according to the manufacturing plant, thereby increasing its accuracy. In addition, the ESM is also able to provide production improvements to increase the energy efficiencies and optimisation within production. These improvements can be factored in during the concept design phase so that design decisions are a result of optimised functionality as well as minimised energy embodiment. Through the integration of the suite of tools for DfEM, other design strategies can be established in combination so as to meet the environmental objectives. An overview of the DfEM tools is shown in Figure 10.9.



	Concept Design (CD)	Detail Design (DD)	Manufacture (M)
Tools that can be applied	<ul style="list-style-type: none"> Brainstorming Morphological box TRIZ Axiomatic Design Systematic Design Simplified LCA 	<ul style="list-style-type: none"> QFD FMEA Value Analysis DfA/DfM DfX DfEM 	<ul style="list-style-type: none"> Computer Aided Manufacture Computer Aided Process Planning Just in Time Manufacturing Lean Manufacturing Energy Management Systems
Design for Energy Minimisation	<p>Simplified Lifecycle Assessment</p>  <ul style="list-style-type: none"> Material selection Process Selection 	<p>Energy Simulation Model</p>  <ul style="list-style-type: none"> Process Parameter Selection Machine Selection Facility services selection 	<p>Advanced Energy Metering System</p>  <ul style="list-style-type: none"> Energy monitoring of Processes Energy demand management

Figure 10.9: Application of various tools in a product design process to aid energy minimisation

10.7 Using Energy Simulation Model (ESM) as part of DfEM

As shown in Section 10.6.2. the Energy Simulation Model consists of an energy database, a simulation engine and a decision support tool. The ESM is primarily based on the energy modelling framework described in this thesis. The simulation engine is supported by an energy database which would provide a back end database comprising of material, process and production energy related data. Together with the product and engineering specifications, the simulation engine would be able to establish the energy consumed during the production phase of the product. The outputs of the simulation will indicate the energy ‘hotspots’ which can then be used to provide focus for energy improvements within manufacturing. So as to ensure that these improvements do not impede the design and quality of the product, they can be assessed through the decision support matrix which evaluates the energy optimisation solutions against the design specification of the product.

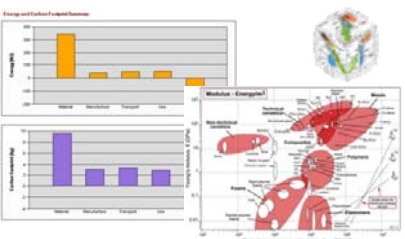
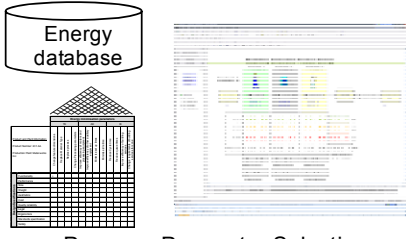
Details of the database, the simulation engine and the decision matrix will be further described in the following sections.

10.7.1 Energy Database

The energy database is the knowledge base element of ESM. Initial data can be determined either theoretically or empirically and statistical relationships can eventually be established to train the simulation engine to predict the amount of energy consumed by the processes and activities for different production parameters such as batching, queue times, process routing and process set ups.

As the energy model becomes more robust, the data output from the predictive models can in turn be added into the energy database to build up a comprehensive understanding of the energy requirements of processes and manufacturing systems. It should be noted that the data related to energy consumption within logistics and reverse logistics activities can also be included. The energy database also provides the simulation engine with the primary energy information such as energy values associated with the manufacturing processes and auxiliary activities. Figure 10.10 shows an example of a database model structure.

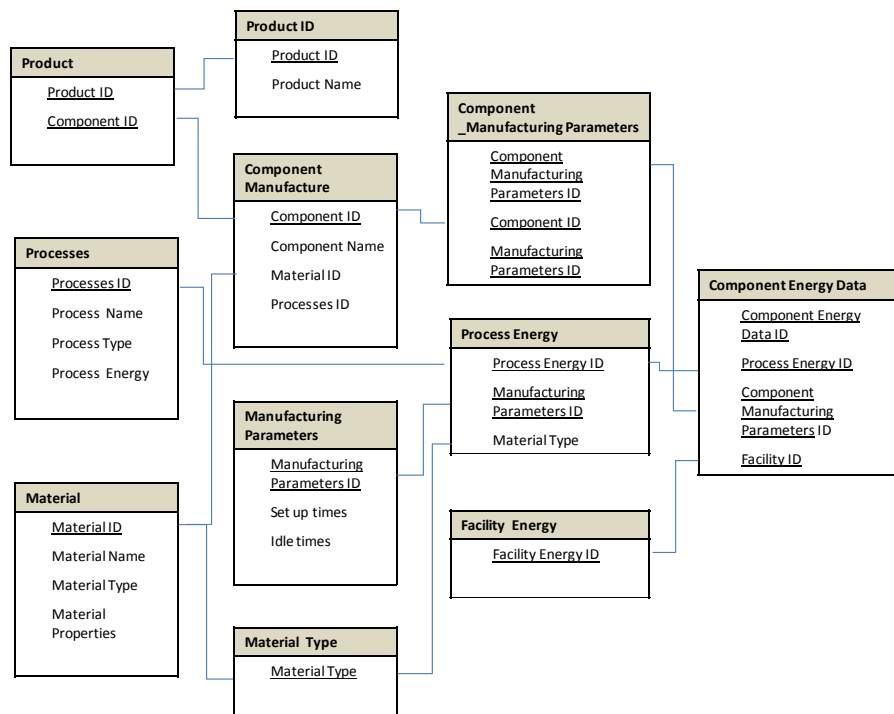

Figure 10.10: An example of a database model structure to store and organise energy data

10.7.2 Simulation Engine

The simulation engine described in detail in Chapter 9 is used to calculate and synthesise the energy use and energy efficiency scores for the product which draws on the data within the energy database described earlier together with product and engineering specifications that would be available at the detail design phase. The energy breakdown and efficiency ratios generated by the simulation engine would allow the designers or engineers to target the most energy intensive processes for energy minimisation. This can provide a focused area for energy optimisation which is essential when the parameters that contribute to overall energy consumption are numerous. The outputs from the simulation engine can be used to populate a list of manufacturing parameters that can be energy optimisation within in the decision support tool which forms the next stage of the DfEM process. Figure 10.11 shows a screen print of the simulation in Arena and the results output in Excel.

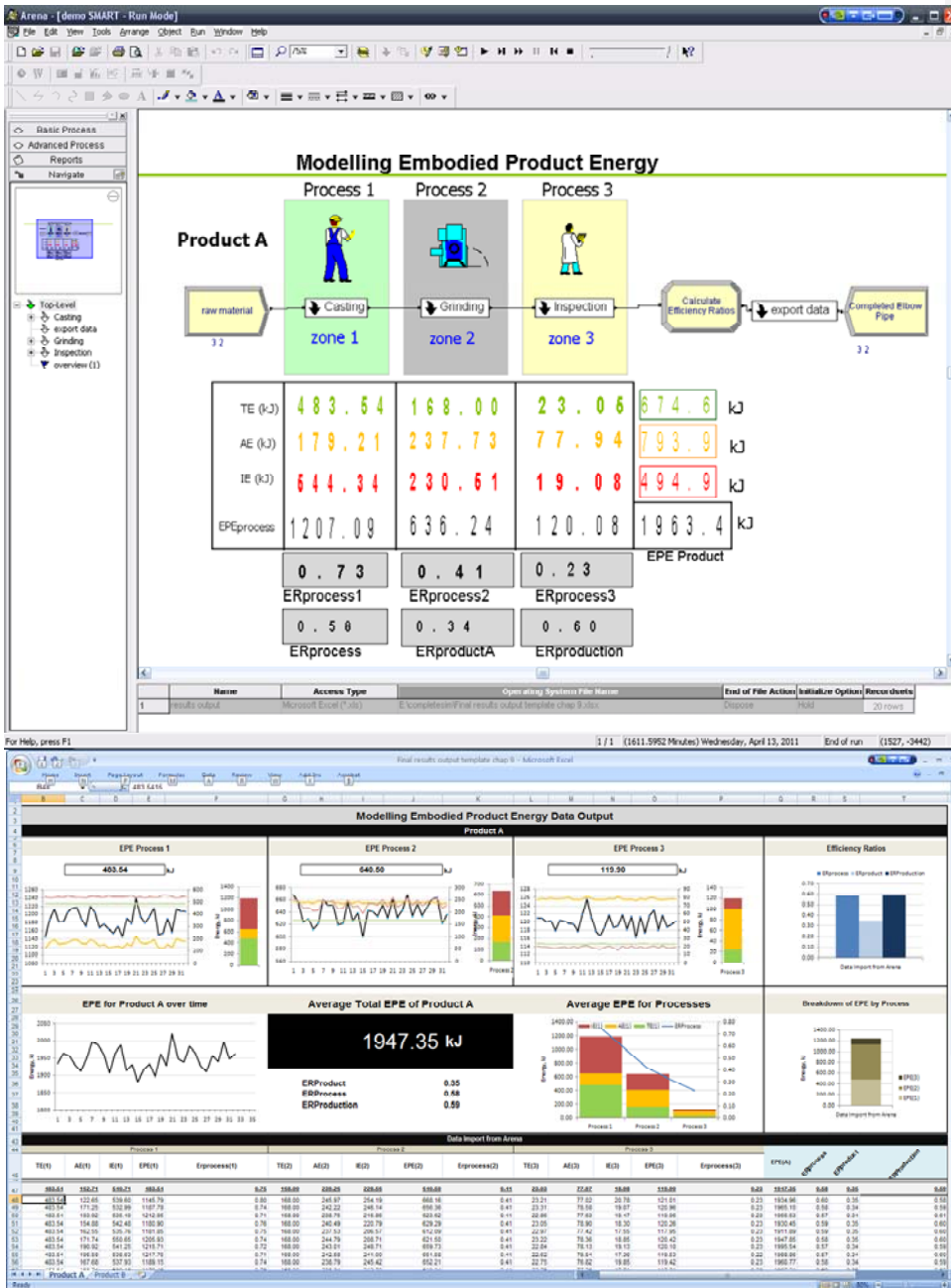

Figure 10.11: The model in Arena (top) with data output in Excel (bottom) showing the average EPE for a batch of products

10.7.3 House of Quality based Design Support Tool

The decision support tool is the final aspect of the ESM. Using the energy breakdown and efficiency assessments obtained from the simulation engine, a range of energy improvement measures can be established. There are several key factors to consider when designing for energy minimisation. For example the reduction of material usage in the design through thinner walls would mean less energy is required during the processing of the material, or, having design features that can be manufactured in the same set up would eliminate the additional energy consumption for a new set up and energy consumed between set ups. Other factors have been listed in Table 10.1.

These factors need to be taken into account with other design specifications and hence should be evaluated together. The HOQ matrix thus provides a tool for correlating the design specification against the manufacturing requirements to help the designer or the engineer arrive at an ideal solution.

Comment [Y11]: Dfem changes

Key Factors to consider for Design for Energy Minimisation	
<i>Design consideration</i>	<i>Impact on energy consumed during manufacture</i>
Use of minimal wall thickness	Reduces material usage and therefore the energy for processing.
Use of alternative materials that require less energy to process	Some materials have lower processing temperatures and so require less energy to process.
Design product features so that they can be manufactured with minimal number of processes	By minimising the number of different processes, less energy is required to set up the machine for a new process and less energy is required for holding the part between processes.
Design features so they can be manufactured using the minimum number of set ups	Having features that can be manufactured in one set up eliminates energy losses during and between set ups.
Design products that be manufactured using least energy intensive processes	Features that can be manufactured using least energy intensive processes will reduce energy consumption during manufacture.
Eliminate unnecessary features that have to be manufactured using a separate process.	Reduce the number of features that require separate operations.
Design parts to be fabricated to near net shape and finish to eliminate the need for additional processes	Eliminates the need for secondary operations, i.e. painting, polishing etc.

Table 10.1: Key Factors to consider for Design for Energy Minimisation

However it is essential that improvements to the production processes can optimise energy use without compromising the original design specification. As such there is a need for a decision support tool that can evaluate the changes to the processes as well production against the design parameters. The House of Quality (HOQ) based design support tool that has been developed as part of the ESM and is illustrated in Figure 10.12. which has been divided into 4 main areas as annotated in the diagram.

A typical HOQ matrix correlates between different needs (e.g. engineering, manufacturing, design). In this tool, a range of design attributes and production related energy improvements are assessed against each other (as shown in area 1). The design attributes can be derived from a product design specification and would include considerations such as aesthetics, ergonomics, costs, functionality and safety.

The production related improvements follow the embodied product energy framework and is divided into 3 different categories of Theoretical Energy (TE), Auxiliary Energy (AE) and Indirect Energy (IE). The energy improvements for the TE are typically related to the type of manufacturing process used, for the AE, to the production equipment used and for the IE, to the processes used to maintain the facility environment. An example of energy improvement under IE would be the use of efficient lighting systems. The improvements can vary depending on the production facility.

Depending on the output of the simulation model priority may be given to one category over the other (as shown in area 2) and through a correlation matrix (as shown in area 3), changes to the manufacturing parameters can be evaluated against the functional requirements of the product to derive the design that has minimal energy consumption during production phases of a product life cycle but also meets the design specifications. For example if the output of the simulation indicates that the TE has the greatest contribution to the energy used, and energy can be optimised through the reduction of cutting speeds. The impact of lower cutting speeds is then considered alongside design attributes such as aesthetics. In this case it might be unfavourable as lower cutting speeds might result in a surface finishing that is unacceptable for the customer.

The manufacturing parameters can also be correlated to establish if they are mutually supporting or contradictory (shown as area 4). For example reducing feature dimensions might reduce cycle time and thus would be a beneficial energy improvement to both on the TE and the IE.

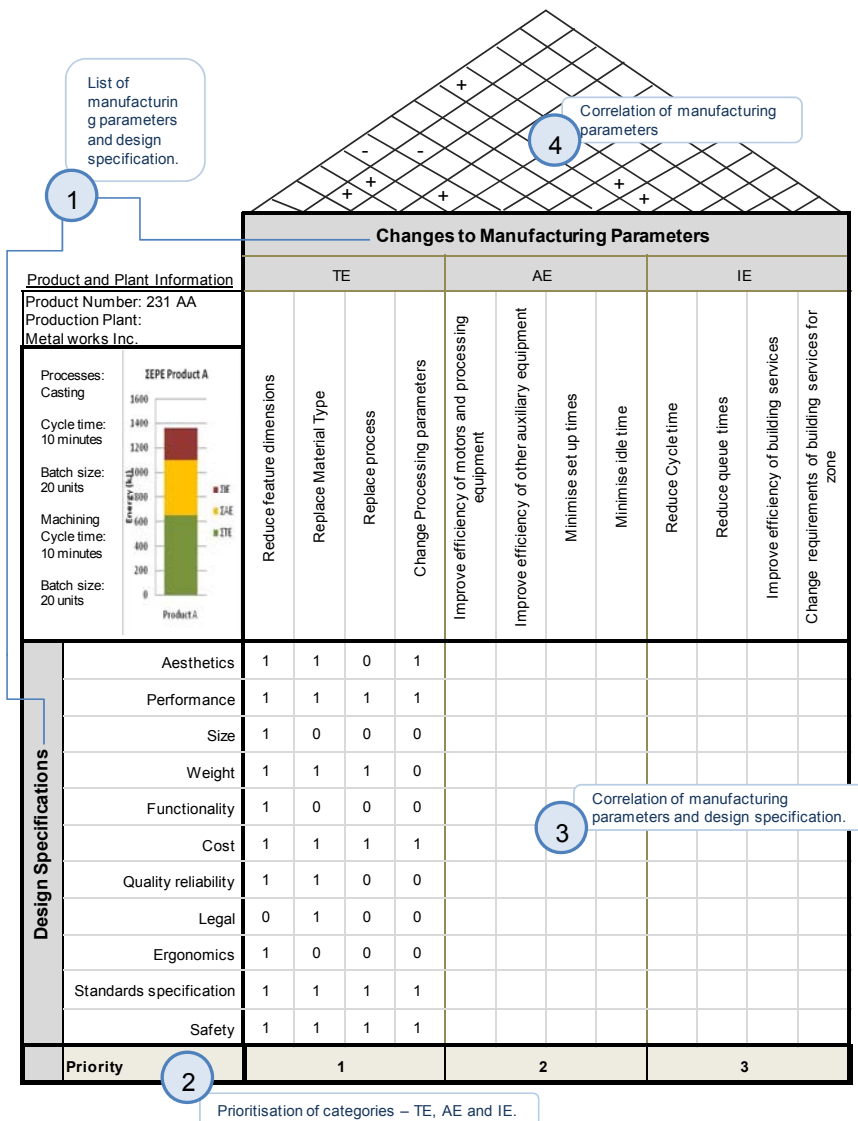

Figure 10.12: HOQ based design support tool for Energy minimisation of the production phase against common design specifications

10.8 Application of DfEM in Centralised and Decentralised Design

The adoption of the proposed DfEM methodology and simulation tool within a design process will depend on the complexity and the number of designers that are involved within the product development. In this thesis, two main types of design strategies have been adopted to explore how DfEM can be applied within various industrial applications. The first is based on the design of a simple product and where the majority of the design decisions are controlled and made centrally within a company; the second is based on a complex product with a large number of components and subassemblies where the design decisions are often distributed across several tiers of suppliers.

In the case of a simple product design, all of these phases are typically managed by a single design team, whereas in the case of a complex product, more than one design team is often involved in the design process. In such cases a distributed design model, typically referred to as ‘V’ model, is adopted. The ‘V’ model was initially developed in Germany for the defence programs and is now commonly used in systems development to simplify the complexities associated with it.

An example of complex designs that are loosely based on the ‘V’ model can be found within the Ford Motor company where vehicles consist of a large number of assemblies and sub assemblies, many of which are manufactured by their suppliers and they must all properly function together. According to Otto and Wood (2001), in the Ford product development approach, the specifications for the new vehicles are defined by the manufacturer, after which the product attributes are cascaded down to individual suppliers. In turn, these suppliers may use one of their component suppliers to manufacture the required subassemblies, resulting in the involvement of many designers at the system, subsystems, and eventually the component levels. Figure 10.13 shows the difference in the product development between a simple product and a complex product.

For a simple product like a plastic chair, various energy considerations and goals can be defined for the product at the start of the development phase and while creating a Product Design Specification (PDS). The respective tools and applications are shown in Figure 10.14. In this case, the CES Eco Selector can be used to assess the energy requirements for extraction, preparation and processing of various plastics to further narrow down the list of materials that meet the function requirements for this product.

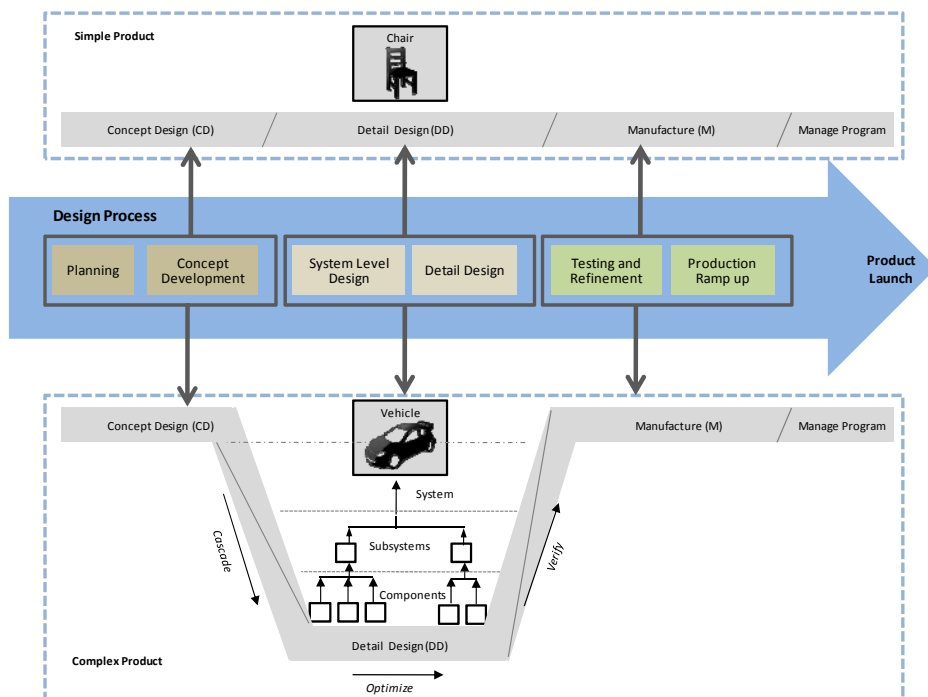

Figure 10.13: Characterisation of the product development process for simple and complex products (Adapted from Otto and Wood, 2001)

This evaluation may show that of the Acrylonitrile-Butadiene-Styrene (ABS) and reinforced Polypropylene (PP) can both fulfil the product specification, but PP is the least energy intensive to extract and prepare. After selection of the material, the DfEM can then be used to evaluate the various production processes that can be used to manufacture the chair using the PP, and provide an indication of the least energy intensive processes. In this case due to specific product geometry, the feasible processes that can be adopted are high impact injection moulding and gas assisted injection moulding. The evaluation of these two processes indicates that the gas assisted injection moulding will potentially consume more energy due to requirements for compressed air. This information could aid the decision making when deciding on the best method of manufacturing of the product and provide designers with a greater insight into energy consumption. Finally during the actual production of the chair, advanced energy metering and management systems can be used to monitor the real time energy consumption by injection moulding, process cooling, drying ovens, heating and ventilation systems as well as lighting to improve the efficiency of the production facility.

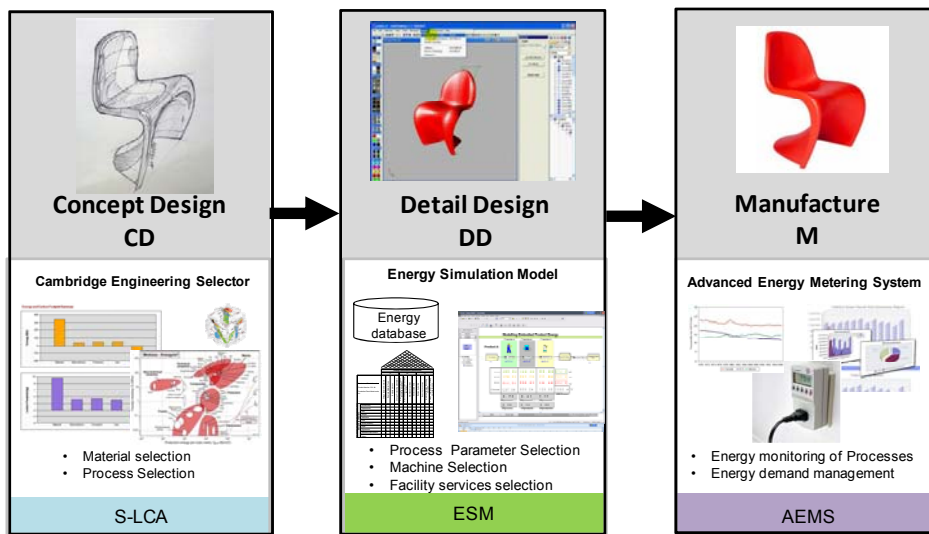

Figure 10.14: Application of DfEM to a Simple product with one design level

The application of DfEM in large complex products requires more detailed consideration, as often a range of designers are involved in the design process. There are two scenarios in which DfEM can be applied in the creation of a complex product.

In the first scenario, the DfEM methodology is applied independently by the design teams in the other levels i.e. design levels 2 and 3, as illustrated in Figure 10.15. The individual teams can apply the DfEM method and specify the design features with the goal of minimising energy requirements over the components life cycle for the parts they were contracted to design.

In the case of a car, the design of various components such as a headlight is either subcontracted to a tertiary level design firm or the OEMs are responsible for the design management of the part. They can apply the DfEM methodology on a local level, i.e. to the light bulb to determine the best way to design and produce the part for energy minimisation as from which develop their own energy product specification.

The light bulbs which are on the tertiary supply tier are then integrated with the headlight module through a secondary level design firm, who could implement the DfEM methodology on the module. The DfEM methodology is used independently throughout the supply chain as the suppliers or design firms in the respective tiers are responsible for the component that they have been subcontracted to design/produce.

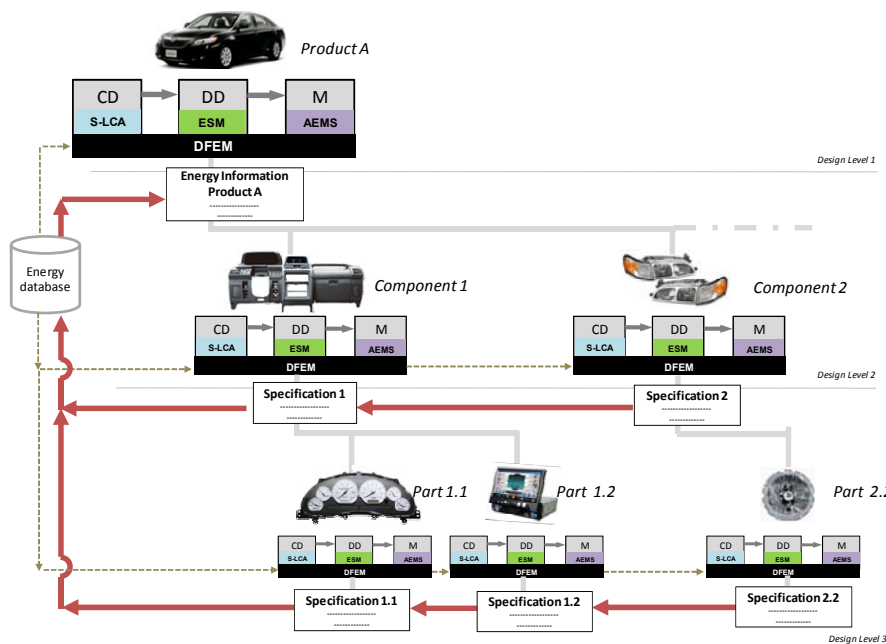

Figure 10.15: Independent use of DfEM across the supply chain

The energy specifications of each individual component or module can be centrally managed through a database so that information from the respective tier can be gathered and amalgamated for the level above. The information can also be added to the Ecodesign Knowledge System (Dewulf, 2003) which provides a centralised system for environmental and design knowledge which provides a platform for sharing knowledge that can be transferred to other design projects (Dewulf and Duflou, 2004).

The overall energy information of the product, i.e. the car, can be established through the energy specifications of each individual part and component. This system is particularly useful in light of the EuP directive where manufacturers have to state the amount of the energy used in the manufacture of a product. The database can also serve as a knowledge base for OEMs, contractors and subcontractors to share knowledge which can help their DfEM process as well as benchmark against other competitors.

This bottom up approach would provide manufacturers with the opportunity to improve the energy performance of their manufacturing facilities based on their capabilities and capacity. However for small contractors with limited resources, implementing an in-house DfEM process might not be possible.

In the second scenario, the team responsible for the overall product i.e. Design level 1, applies the design for energy minimisation to the product system (including components and subcomponents) and disseminates the design criteria and specifications to the other design teams as shown in Figure 10.16. As such DfEM needs to be employed throughout the “design chain” activities, and the coordination of these activities needs to be managed by the company at the top level to ensure the common goals are cascaded throughout the design chain.

Clearly in support of this coordination process, a centrally managed database of energy related information needs to be made available to all the design levels. This will enable the designers to retrieve information related to the products at the levels above or below the level that they are working at. For complex products with a large number of components, the team at the top level may not have all the information and knowledge to establish the initial specification, so the database can enable the contract manufacturers themselves who have expert knowledge on the specific components to share knowledge with the design team at level 1 and enable a more realistic energy specification to be created in the first place. As the database grows, it would be easier for the company at the top to generate the DfEM specification.

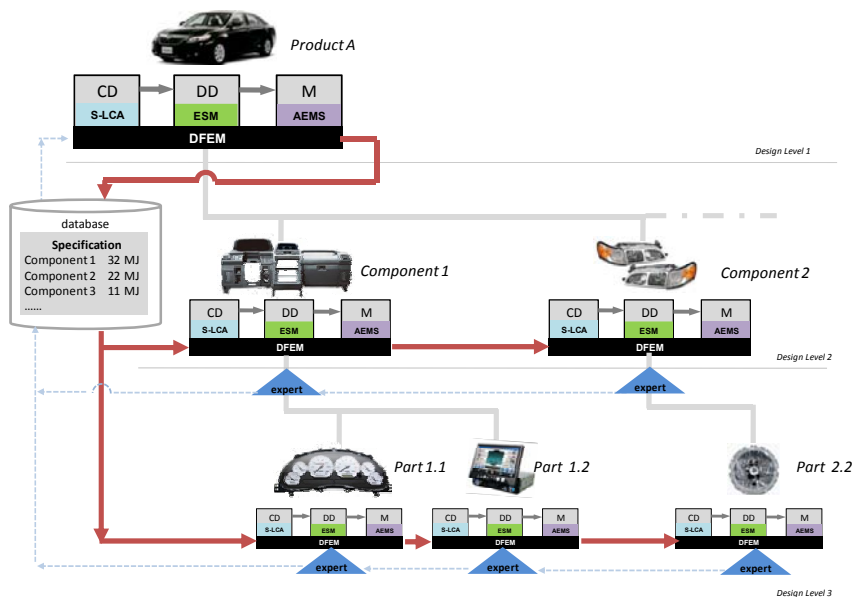

Figure 10.16: Application of DfEM tools to distributed design for complex products such as a car

10.9 Chapter Summary

Design is an integral part of any product development process and much of the decisions taken at this stage accounts for the majority of the financial and environmental cost of a product. Therefore to reduce the energy consumption of a product during the production phase, energy considerations need to be included at the design stage. By identifying where the energy is used during production and how productively it is used, the designer gains an insight into the energy effectiveness of the process in relation to a product. This knowledge can empower the designer to intelligently explore the suitability of a product feature, a material and consequently the chosen manufacturing process with energy minimisation in mind.

The DfEM methodology presented in this chapter has been developed with the requirements of modern design challenges in mind and provides tools for high level design decisions as well as lower level energy auditing. The ESM tool specifically developed as part of this research bridges the gap between the two. The simulation tool would enable designers to do ‘what if’ scenarios to identify the most practical and economically feasible design improvements that could reduce the need for energy consumption during manufacture. The decisions for energy minimisation can now be taken at the early stages of the design process.

The implementation of the EPE framework within a practical application necessitates the development of a decision support tool that is capable of representing the complexity involved in modelling and calculating the AE, TE, DE and IE for various processes in a typical production system. Especially for complex products like cars that may consist of thousands of components, a model is required to record and analyse the processing parameters of each component and relate it to the energy consumption that can be attributed to each component. This chapter has also demonstrated the applicability of the ESM model within the design phase and has shown how DfEM can be incorporated within the design chain of both simple and complex products.

Chapter 11 Case Studies

11.1 Introduction

This chapter discusses two sets of case studies that have been used to demonstrate the applicability of research concepts related to the Embodied Product Energy framework and associated simulation model described within this thesis. The chapter begins by providing an overview of these case studies. In the first case study, a simple example product has been used to demonstrate various calculations and methods for energy data generation described as part of the EPE framework. The second case study is used to evaluate the applicability of the energy simulation model and demonstrate how this model can be used to support the minimisation of energy consumption during production phase of a product's life cycle through a combination of improvements in operation and product design.

11.2 Description of the Case Studies

This thesis has introduced several new facets to energy modelling within a production system through the development of the EPE framework. The energy considerations on a process and facility level are integrated within the framework to provide a novel viewpoint in energy modelling based on a product view to provide greater transparency of the breakdown of energy consumption and to highlight energy hotspots for further analysis. The case studies aim to assess the validity of the modelling approach for the energy consumption during the manufacture of the products. The energy framework and simulation model described in the earlier chapters will be used to establish the energy intensive processes associated with the manufacture of these products, which follows with an assessment of the efficiencies of the manufacturing processes and production system through the use of energy efficiency ratios developed in this thesis. The results of the analysis will then be used to support design improvements through the DfEM methodology previously discussed in Chapter 10. The specific issues that will be addressed by these case studies are:

- Applicability of the framework
- The implementation of the simulation model
- Assessment of the suitability of the efficiency ratios.
- The use of simulation outputs to support design for energy minimisation

The case studies have been selected to provide an exemplification of the framework and the simulation model. The first case study is based on a single product and is designed to show how the framework can be applied and to demonstrate the calculations involved. A simple product, an elbow pipe requiring three production processes was assessed using the EPE model and the DE and IE was established by using published data based on other similar products.

The second case study demonstrates the capabilities of the simulation model and evaluates the functionality of the efficiency ratios. The results of the analysis are also applied to the Design for Energy Minimisation methodology to show how the energy simulation can be used to improve design decisions. The three metal products 1) a solenoid cover found in an air freshener dispenser, 2) a mini metal football table and 3) a bucket tooth used in excavators, have been selected for the second case study. These products were chosen as they were fairly simple products requiring commonly used manufacturing processes such as casting, milling and drilling. An overview of both case studies is shown in Figure 11.1.





	Case Study 1	Case Study 2		
Product				
	Elbow Pipe	Coil Sheath for Air Freshener	Mini Football Table	Excavator Bucket Tooth
Processes	Casting Grinding Inspection	Casting Milling Inspection	Milling Drilling Inspection	Casting Inspection
Purpose	Application of EPE framework Demonstrate Calculations	Application of EPE framework Demonstrate capabilities of simulation model Evaluate the functionality of the efficiency ratios Application of DfEM methodology		

Figure 11.1: Overview of case study 1 and case study 2

11.3 Case Study 1: Application of EPE Framework in the Case of a Simple Product

This case study is based on the fabrication of an aluminium alloy elbow pipe that requires 3 main processes in its production, namely casting, grinding and inspection. Each process requires a different manufacturing environment, with casting carried out in Zone 1, grinding in Zone 2 and ultrasonic inspection in Zone 3.

Table 11.1 shows the processes required in the fabrication of the elbow pipe and the associated equations and method used to establish the TE, AE and IE. In this example, the elbow pipe will be denoted as Pipe A. The DE values for this product will be determined through theoretical equations as well as empirical methods. The assumed throughputs of the product are 24 units/hr for Zone 1, 20 units/hr for Zone 2 and 30 units/hr for Zone 3 based on typical throughput rates in a production plant that makes a similar product. The values used in the calculations are summarised in Table 11.2.

Case Study 1			
Pipe A			
			
Product Detail	Elbow Pipe		
Material	Aluminium Alloy		
Processes required	Casting (zone 1) 24 parts/hour	Grinding (zone 2) 20 parts/hour	Inspection (zone 1) 30 parts/hour
TE Equation	$mC(T_m - T) + mL$ m, Mass of part (kg) C, Specific heat capacity (kJ/kg) T, Temperature of metal before melting (K) T _m , Melting temperature of metal (K) L, Latent heat of melting (kJ/kg)	UV U, specific cutting energy (J/mm ³) V, volume of part to be removed (mm ³)	NPT N, number of transmitters P, power of transmitters (W) T, duration of operation (sec)
AE	Determined empirically	Determined empirically	Determined empirically
IE for each zone	Determined empirically	Determined empirically	Determined empirically

Table 11.1: Processes required by case study 1 and the respective equations used to establish the TE for the processes

Data Inputs for Case Study 1			
Energy attribution	Parameters	Elbow Pipe 	
Casting	TE	m, Mass of part (kg)	0.5
		C, Specific heat capacity (kJ/kgK)	0.46
		T, Temperature of metal before melting (K)	298.15
		Tm, Melting temperature of metal (K)	1809.2
		L, Latent heat of melting (kJ/kg)	272
	AE	Vacuum generation (kJ)	100
		Process Inefficiencies (kJ)	50
	IE	Tp, Throughput (parts/hr)	24
IEzone1 (kJ/hr)		4000	
Grinding	TE	U, Specific Grinding Energy (KJ/mm ³)	0.050
		V, Volume of material removal (mm ³)	3360
	AE	Coolant Pump (kJ)	137
		Process Inefficiencies (kJ)	60
	IE	Tp2, Throughput of zone 2 (parts/hr)	20
		IEzone2 (kJ/hr)	1200
Inspection	TE	N, number of transmitters	8
		P, power of transmitters (W)	0.5
		t, duration of operation (sec)	120
	AE	Conveyor System (kJ)	76
		Process Inefficiencies (kJ)	25
	IE	Tp3, Throughput of zone 3 (parts/hr)	30
		IEzone3 (kJ/hr)	1000

Table 11.2: List of data inputs for Case Study 1

11.3.1 Calculating DE for Product A

To establish the total DE for Pipe A the DE for each process needs to be calculated. The theoretical and the auxiliary energy for casting, grinding and inspection will first be calculated separately and subsequently added together at the end to establish the total DE.

11.3.1.1 DE for Process 1 (Casting)

The TE required by the casting process can be calculated by using Equation 8.1 which is the energy needed to melt the metal. Using a similar elbow pipe, it was weighed and found to have a mass of 0.5 kg which was then used for the calculations. As noted in most casting processes, the metal ingot is heated from room temperature to melting point which is 1809.2 K for the aluminium alloy. The equation and values for the other parameters are shown in Table 11.3. The main contributors to the AE of the casting process were the generation of a vacuum for the mould and general process inefficiencies. The data for AE was established empirically and is also shown in Table 11.3.

$$TE(1)_A = mC(T_m - T) + mL \quad \text{[Equation 8.1]}$$

Where,

M is the mass of the part that is cast (kg)

C is the specific heat capacity of the material cast (kJ/kgK)

T_m is the melting temperature of the material (K)

T is the temperature of the material before melting (K)

L is the latent heat of melting of the material (kJ/kg)

Energy	Parameter	Value	Calculation
TE	m	0.5 kg	$TE(1)_A = mC(T_m - T) + mL$ $= 0.5 * 0.46(1809.2 - 298.15) + 0.5 * 272$ $= 484 \text{ kJ}$
	C	0.46 kJ/kgK	
	T_m	1809.2 K	
	T	298.15 K	
	L	272 kJ/kg	
AE	Vacuum	100 kJ	$AE(1)_A : \text{Vacuum} + \text{Process Inefficiencies}$ $= 100 + 50$ $= 150 \text{ kJ}$
	Process Inefficiencies	50 kJ	

Table 11.3: The values of the parameters for the elbow pipe for the casting process and the calculation of theoretical energy.

11.3.1.2 DE for Process 2 (Grinding)

After casting, the part is sent for grinding to achieve the required surface finish. The TE required by the grinding process for Pipe A, was determined using Equation 11.1 and the specific grinding energy is estimated to be 0.050 kJ/mm³ as given by Rao (2000). In the grinding process, 3360 mm³ of material is removed from each pipe. The main contributors to the AE of the grinding process are the pumping of coolant and general process inefficiencies. The data for AE was established empirically and is also shown in Table 11.4.

$$TE(2)_A = UV \text{ [Equation 11.1]}$$

Where,

U is the specific grinding energy of the material (J/mm³)

V is the volume of material removed (mm³)

Energy	Parameter	Value	Calculation
TE	U	0.050 kJ/mm ³	$TE(2)_A = UV$ $= 0.05 \times 3360$ $= 168 \text{ kJ}$
	V	3360 mm ³	
AE	Coolant	137 kJ	$AE(2)_A = \text{Coolant} + \text{Process Inefficiencies}$ $= 137 + 60$ $= 197 \text{ kJ}$
	Process Inefficiencies	60 kJ	

Table 11.4: The calculation of the TE and AE for process 2, Grinding

11.3.1.3 DE for Process 3 (Inspection)

Once the part has been cast and the desired surface finish has been attained through the grinding process, it is sent for inspection to check for internal flaws and to ensure uniformity in its thickness. This is achieved through sending ultrasonic pulse-waves through the pipes. The TE required by the inspection process for Pipe A, is determined using Equation 11.2 which works out the energy required by the ultrasonic transmitters base on the power rating and the number of transmitters. It is assumed that 8 transmitters each with a power of 0.5W are used in the inspection process. The final energy consumption of the TE is tabulated in Table 11.5. The main contributor to the AE of the inspection process is due to the conveyor system which provides an

automated transportation for the parts from the grinding process to the inspection process. The data for AE was established empirically and is shown in Table 11.5.

$$TE(3)_A : N_{trans} * P * T \text{ [Equation 11.2]}$$

Where,

N_{trans} is the number of transmitters

P is the Power of transmitter (W)

T is the duration of operation (s)

Energy	Parameter	Value	Calculation
TE	N_{trans}	8	$TE(2)_A = N_{trans} * P * T$ $= 0.48 \text{ kJ}$
	P	0.5 W	
	T	120 sec	
AE	Conveyor system	76 kJ	$AE(3)_A = \text{Conveyor System}$ $= 101 \text{ kJ}$
	Process Inefficiencies	25 kJ	

Table 11.5: The calculation of the TE and AE for process 3 Inspection

11.3.2 Calculating IE for Pipe A

To establish the total IE for Pipe A, the energy consumed by the services required for the facility needs to be calculated. The areas with uniform ambient energy requirements are classed as a single zone. In the case of the elbow pipe, each of the processes has different IE requirements thus they have been allocated to different zones. Casting has been denoted as Zone 1, the grinding process as Zone 2 and the inspection process as Zone 3. The IE for Zone 1 is based on the energy consumed for lighting, specialised air conditioning and air extraction for the casting process and for Zone 2 is based on lighting and ventilation and, Zone 3 is based on a higher lighting density and air conditioning. The IE has been assumed to be 4000kJ per hour for Zone 1, 1200 kJ per hour for Zone 2 and 1000 kJ per hour for Zone 3. The attribution of energy consumed by each zone to a unit product manufactured within the zone can be calculated using the Equation 8.4 shown below and the results are shown in Table 11.6.

$$IE_{zone(m)A} = IE_{zone(m)}/TP_{zone(m)A} \quad \text{[Equation 8.4]}$$

Where,

$IE_{zone(m)A}$ is the indirect energy attributed to Pipe A for Zone m per hour

$IE_{zone(m)}$ is the indirect energy consumed by zone m per hour

$TP_{zone(m)A}$ is the throughput of Pipe A per hour in zone m

Energy	Parameter	Value	Calculation
IE(1) _A	IE_{zone1}	4000 kJ/h	$IE_{zone(1)A} = IE_{zone(1)}/TP_{zone(1)A}$ = 4000/24
	TP_{zone1}	24 /hr	= 167 kJ
IE(2) _A	IE_{zone2}	1200 kJ/hr	$IE_{zone(2)A} = IE_{zone(2)}/TP_{zone(2)A}$ = 1200/20
	TP_{zone2}	20 /hr	= 60 kJ
IE(3) _A	IE_{zone3}	1000 kJ/hr	$IE_{zone(3)A} = IE_{zone(3)}/TP_{zone(3)A}$ = 1000/30
	TP_{zone3}	30 /hr	= 33 kJ

Table 11.6: The calculation of IE for all 3 processes

11.3.3 Calculating EPE for Pipe A

To establish the EPE for Pipe A, the sum of the DE for all the processes (i.e. process 1, 2 and 3) are added to the sum of IE for the zones (i.e. zones 1,2 and 3) as denoted by Equation 8.6. The final EPE calculations are shown in Table 11.7.

$$EPE_A = \sum_{i=1}^n DE(i)_A + \sum_{j=1}^m IE_{zone(j)A} \quad \text{[Equation 8.6]}$$

Where,

$IE_{zone(m)A}$ is the indirect energy attributed to Pipe A

$IE_{zone(m)}$ is the indirect energy consumed by zone m per hour

$TP_{zone(m)A}$ is the throughput of Pipe A per hour in zone m

Using the EPE model, the final EPE of Pipe A, the elbow pipe is calculated to be 1360 kJ. Of the total EPE, the DE accounted for 1100 kJ while the IE accounted for the balance. To assess the efficiency of the processes the efficiency ratios will be calculated next.

Energy	Parameter	Value (kJ)	Calculation
DE _A	TE(1) _A	484	$DE_A = \sum_{i=1}^3 TE(i)_A + AE(i)_A$ $= 484 + 168 + 0.48 + 150 + 197 + 101$ $= 652.48 + 448 \text{ kJ}$ $\approx 1100 \text{ kJ}$
	TE(2) _A	168	
	TE(3) _A	0.48	
	AE(1) _A	150	
	AE(2) _A	197	
	AE(3) _A	101	
IE _A	IE(1) _A	167	$IE_A = \sum_{j=1}^3 IEzone(j)_A$ $= 167 + 60 + 33$ $= 260 \text{ kJ}$
	IE(2) _A	60	
	IE(3) _A	33	
EPE_A			$EPE_A = \sum_{i=1}^3 DE(i)_A + \sum_{j=1}^3 IEzone(j)_A$ $= 1100 + 260$ $= 1360 \text{ kJ}$

Table 11.7: The calculation of the EPE for Pipe A.

11.3.4 Efficiency Ratios of Pipe A

The efficiency ratios for the processes, product and production system (previously described in Chapter 8) can be determined using Equations 8.8 to 8.11 as shown below.

The calculations are summarised in Table 11.8.

$$0 < ER_{process(n_A)} = \frac{TE(n_A)}{DE(n_A)} < 1 \quad \text{[Equation 8.8]}$$

$$0 < ER_{processA} = \frac{TE_A}{DE_A} < 1 \quad \text{[Equation 8.9]}$$

$$0 < ER_{productA} = \frac{TE_A}{EPE_A} < 1 \quad \text{[Equation 8.10]}$$

$$0 < ER_{plant} = \frac{DE}{EPE} < 1 \quad \text{[Equation 8.11]}$$

Energy Efficiency Ratios	Parameter	Value	Calculation
ER _{process}	ER _{process(1A)}	0.76	$0 < ER_{process(n_A)} = \frac{TE_{n_A}}{DE_{n_A}} < 1$ ER _{process(1A)} = 484/634 = 0.76
	ER _{process(2A)}	0.46	ER _{process(2A)} = 168/365 = 0.46
	ER _{process(3A)}	0.0048	ER _{process(3A)} = 0.48/101.48 = 0.0048
	ER _{process(A)}	0.59	$0 < ER_{processA} = \frac{TE_A}{DE_A} < 1$ ER _{process(A)} = 652.48/1100.48 = 0.59
ER _{product}	ER _{product(A)}	0.48	$0 < ER_{productA} = \frac{TE_A}{EPE_A} < 1$ ER _{product(A)} = (484+168+0.48)/(1360.48) = 0.48
ER _{plant}	ER _{plant(A)}	0.81	$0 < ER_{plant(A)} = \frac{DE}{EPE} < 1$ ER _v = 1100.48/1360.48 = 0.81

Table 11.8: Calculation of efficiency ratios for the process, product and production system.

The ER_{process(n_A)} for Process 1_A (casting), Process 2_A (grinding) and Process 3_A (Inspection) was calculated to be 0.76, 0.46 and 0.0048 respectively. The overall ER_{process} for the manufacture of Product A was 0.59, the ER_{product} for Pipe A was 0.48 and the ER_{plant} was 0.81.

11.3.5 Analysis of Results for Case Study 1

In the manufacture of the elbow pipe (Pipe A), the casting process consumed the greatest amount of energy (800 kJ) followed by grinding (425 kJ) and the inspection process (135 kJ), as shown in Figure 11.2. Despite casting being the most energy intensive, only a small proportion of the total process energy is wasted through non-productive activities related to IE and AE. This is apparent by the high value for the $ER_{process}$ for casting (0.76). However in the case of the grinding and inspection processes, despite being less energy intensive, more than half of the total process energy is due to the non-productive activities related to the auxiliary and indirect energy requirements. This is reflected in the low process efficiency ratios for the grinding (0.46) and inspection processes (0.0048), as shown in Figure 11.3. The poor process efficiency of the inspection process is due to the large proportion of energy required to power the conveyor system in comparison to a small amount of energy required to power the transmitters for the inspection process.

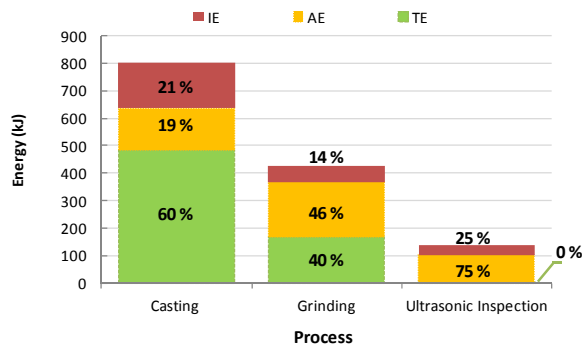

Figure 11.2: Breakdown of energy consumption for the manufacture of the elbow pipe (Pipe A)

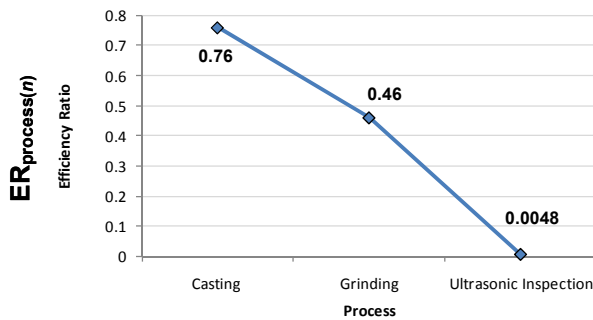

Figure 11.3: Plot of Process Efficiency Ratios, $ER_{process(n)}$, for each of the processes used to manufacture Pipe A – casting, grinding, ultrasonic inspection

In general, the processes required in the manufacture of Pipe A consumed more energy for “value added” processing (i.e. TE) than for the supporting auxiliary activities (i.e. AE). The theoretical energy accounts for almost half of all the energy consumed (48%) by the processes, as illustrated in the pie chart in Figure 11.4.

Furthermore the comparison the TE and the EPE through the $ER_{\text{product}(A)}$ which is 0.48 for Pipe A indicates that the product could theoretically be manufactured more efficiently. This highlights potential for energy improvements to the auxiliary processes and the provision of facilities services. For example, the operational procedures of production equipment (e.g. grinding machine or conveyor systems) could be further examined to reduce auxiliary energy consumption from idle modes of operation or unnecessary supporting processes.

Overall on a facility level, the production system is fairly efficient as reflected in a high $ER_{\text{plant}(A)}$ ratio of 0.81. This is indicative that from the total energy consumed, only 19% of the energy can be attributed to indirect energy consumption by the facility. The ratios have been summarised in a column graph as shown in Figure 11.4. Despite the relatively small proportion of IE, further energy improvements can be made to the facility services in Zone 1 (Casting) as it was the highest IE consumer. For example heat recovery systems can be installed within the facility to minimise the energy load of the air conditioning systems within the casting facility.

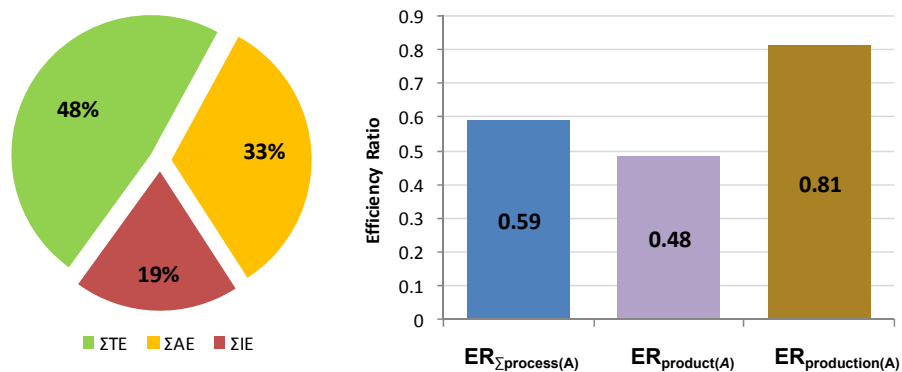

Figure 11.4: Pie chart indicating the percentage breakdown of TE, AE and IE for Pipe A (left) and the efficiency ratios for the process, product and plant (right)

11.4 Case Study 2: Multiple Products

The second case study is based on three metal products each with different processing requirements. The first product is a coil sheath for an air freshener dispenser and is called Product A in this case study. It is made of cast iron and is first cast then milled and inspected upon completion. The second product is a mini football table (Product B) first milled from a block of aluminium followed by a drilling process and finally inspected. The third product is a bucket tooth for an earth excavator (Product C) which is produced from cast iron steel and then inspected. The casting process requires a dedicated environmental ancillary plant services such as fume extraction and air filtering and is therefore categorised as Zone 1. The milling and the drilling process are both located in a similar processing environment that requires basic lighting and HVAC systems and is categorised as Zone 2. As the inspection process is automated, the lack of human operators mean that the ambient temperature is not as tightly regulated and as such the energy requirements of the environment is different to the other processes. This is carried out in Zone 3 in this case study. The product details and their processing requirements are summarised in Table 11.9.



Case Study Products			
	Product A 	Product B 	Product C 
Product Detail	Coil Sheath for an Air Freshener Dispenser	Mini Football Table	Excavator Bucket Tooth
Material	Iron	Aluminium	Cast Iron Steel
Processes required	Casting (zone 1) 30 parts/hour	Milling (zone 2) 25 parts/hour	Casting (zone 1) 20 parts/hour
	Milling (zone 2) 30 parts/hour	Drilling (zone 2) 25 parts/hour	
	Inspection (zone 3) 90 parts/hour	Inspection (zone 3) 100 parts/hour	Inspection (zone 3) 60 parts/hour

Table 11.9: Summary of product details used in the case study.

Several assumptions have been made in this case study. The list of assumptions have been compiled in Table 11.10.

Comment [Y12]: Assumption 2

Assumptions		Comments
1.	The mass of the casting is the minimum mass of metal required to fulfil the specification	Any waste or losses during the casting process is accounted for as part of the AE.
2.	The equations used for the TE are representative of the minimum energy required in practice.	<p>The minimum energy for casting a part is the energy needed to raise the temperature of metal to melting point and the energy needed to melting it as given by Ashby <i>et al.</i> (2008)</p> <p>The equation for metal removal is based on previous empirical studies from which the specific cutting energy has been derived (Kalpakjian and Schmid, 2008) and is indicative of the typical energy required to cut the specified metal.</p> <p>The minimum energy for the inspection process is harder to establish. As such an equation for the minimum energy consumption of the transmitters was used to establish the TE.</p>
3.	Auxiliary energy calculations can be expressed as a function of TE	According to Gutowski <i>et al.</i> (2008) the energy consumed by the auxiliary processes can be up to 4 times higher than the energy required to actually cut the material. The AE for this case study has been expressed as a function of TE. The values have been varied depending on the complexity of the feature to be processed and the number of separate sets up required to complete the job, both of which will affect the AE required.
4.	IE has been assumed to be different for different processes	<p>The casting process, zone 1, requires a lot more energy for its environment and the values have been estimated base on a basic casting environment with some lights, air filtration and temperature control and HVAC.</p> <p>The machining and drilling process share the same IE environment, zone 2, and the IE has been estimated based on standard lighting density and some HVAC.</p> <p>The inspection process, zone 3, has a higher lighting density but occupy a smaller area and thus has a lower IE value compared to zone 2.</p>
5.	The average throughput per hour accounts for down times and queue times that occur over a production period	It is possible to calculate the EPE for a particular batch taking into consideration the respective queue times and down times associated with it. However for simplicity and for the purpose of the case study an average throughput value has been used to account for any idle time.

Table 11.10: List of key assumptions associated with Case Study 2

11.4.1 Data Inputs to the EPE Model

The DE of a product requires the TE and the AE to be established. As exemplified through the first case study, the TE can be calculated based on equations that relate the part and processing parameters. For example the casting energy required is calculated as the sum of the energy required to raise the metal to melting point and the energy required to melt the metal. The milling and drilling energies are determined through the specific cutting energy and the volume of material that has been removed. Finally the inspection process is determined by the number of transmitters, the power of the transmitters and then operating time. As the previous case study already demonstrates the use of various mathematical equations in great detail, only a brief overview of the equations used in this case study are shown in Table 11.11.

Due to the lack of actual energy data from the processing equipment, the AE has been estimated as a function of the TE. In the case of the machining processes such as milling and drilling, it has been reported by Gutowski *et al.* (2008) that the energy consumed by the auxiliary processes can be up to 4 times higher than the energy required to actually cut the material. So as to demonstrate a range of auxiliary process energy consumed, a range of AE has been used and varied according to the part complexity in this case study. The AE for the milling process for Product A has been estimated to be 3.5 times higher than the TE requirement (due to the need for two separate machine set ups to mill the features) and 2 times higher in Product B (requires only 1 set up, but requires 2 tool changes). For the drilling process it is estimated to be 2.2 times higher for Product B. The AE for the casting and the inspection process have also been estimated in a similar manner. The full list of data inputs used in this case is shown in Table 11.12. The IE consumption of the zones are 8738 kJ/hour for Zone 1, 1988 kJ/hour for Zone 2 and 1500 kJ/hour for Zone 3.

Processes				
Casting		Milling	Drilling	Inspection
Equation	$mC(T_m - T) + mL$	UV	UV	NPT
	m, Mass of part (kg)			N, number of transmitters
	C, Specific heat capacity (kJ/kg)	U, specific cutting energy (J/mm ³)	U, specific cutting energy (J/mm ³)	P, power of transmitters (W)
	T, Temperature of metal before melting (K)	V, volume of part to be removed (mm ³)	V, volume of part to be removed (mm ³)	T, duration of operation (sec)
	T _m , Melting temperature of metal (K)			
	L, Latent heat of melting (kJ/kg)			

Table 11.11: Equations used to calculate the TE of the processes used in Case Study 2



Data Inputs for Case Study					
Energy attribution	Parameters	Product A	Product B	Product C	
					
Casting	TE	m, Mass of part (kg)	0.48		1.20
		C, Specific heat capacity (kJ/kg)	0.46		0.46
		T, Temperature of metal before melting (K)	298.5		298.5
		Tm, Melting temperature of metal (K)	1493.6		1493.6
		L, Latent heat of melting (kJ/kg)	138		138
	AE	As a function of TE	(0.4)		(0.8)
	IE	Tp, Throughput (parts/hr)	30		20
		IEzone1 (kJ)	8738		8738
Milling	TE	U, Specific Cutting Energy (J/mm ³)	5.6	5.6	
		V, Volume of material removal (mm ³)	11510	29870	
	AE	As a function of TE	(3.5)	(2)	
	IE	Tp2, Throughput of zone 2 (parts/hr)	30	25	
		IEzone2 (kJ)	1988	1988	
Drilling	TE	U, Specific Cutting Energy (J/mm ³)		5.6	
		V, Volume of material removed (mm ³)		8965	
	AE	As a function of TE (kJ)		(2.2)	
	IE	Tp2, Throughput of zone 2 (parts/hr)		25	
		IEzone2 (kJ)		1988	
Inspection	TE	N, number of transmitters	8	8	8
		P, power of transmitters (W)	10	10	10
		t, duration of operation (sec)	12	6	18
	AE	As a function of TE	(3)	(3)	(3)
	IE	Tp3, Throughput (parts/hr)	90	100	60
		IEzone3 (kJ)	1500	1500	1500

Table 11.12: List of data inputs for case study 2 (parenthesis indicate estimated values)

11.4.2 Use of the Simulation Model

To automate the calculations required to establish the embodied product energy for each of the products, Arena was used to build a model to represent the production processes required in the manufacture of the products. The first step was to indicate the point where the product enters the system and this is done using the 'create' modules. Next, 'submodels' were used to represent the processes casting, milling, drilling and inspection. As each of the products had different processing plans, the process routes had to be established for each product. Figure 11.5 provides an overview of the 'create' modules, 'submodels' and the process routes used in the simulation model.

Within each submodel, the part and processing parameters are assigned as 'attributes' and the equations relating the parameters are entered as 'variables'. The data inputs are entered through the 'attributes' modules and the equations are entered as 'variables'. Figures 11.6 to 11.9 show the attributes (product data) and the variables (equations) that have been entered within the model for the four processes for respective products. As the entities (products) move through the system they are assigned the attributes and the respective energy values at each process are calculated using the variables. The model stores the energy information which is then shown and exported after the simulation run.

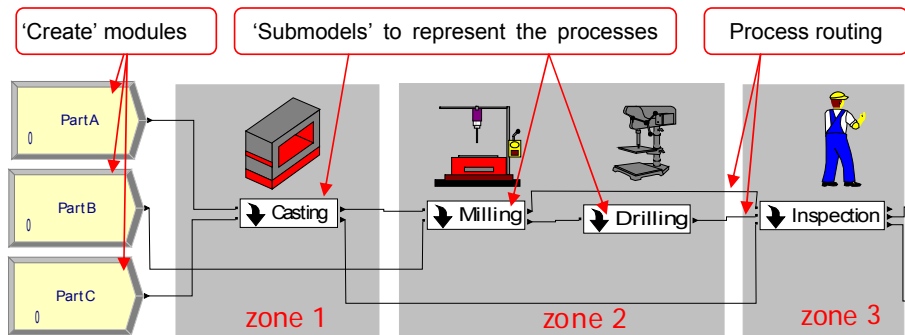
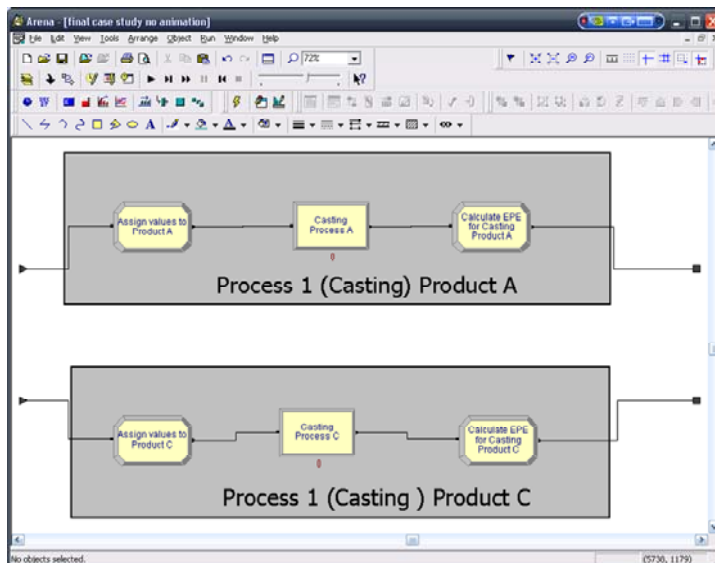

Figure 11.5: The 'Create' modules indicate the point where the products enter the system and the 'Submodels' represent the various production process. The products are then routed through the system according to the processes they require



a) Submodel for Process 1 showing the flow of Product A and Product C.

Assignments				Assignments			
	Type	Attribute Name	New Value		Type	Attribute Name	New Value
1	Attribute	m.A	0.48	1	Attribute	m.C	1.2
2	Attribute	C.A	0.46	2	Attribute	C.C	0.46
3	Attribute	Tm.A	1493.6	3	Attribute	Tm.C	1493.6
4	Attribute	Temp.A	298.5	4	Attribute	Temp.C	298.5
5	Attribute	L.A	138	5	Attribute	L.C	138
6	Attribute	Tp.A	30	6	Attribute	Tp.C	20
7	Attribute	IEzone1.A	8738	7	Attribute	IEzone1.C	8738

b) Assignments of part attributes for Process 1. The windows show the values for Product A (left) and Product C (right)

Assignments					Assignments				
	Type	Variable Name	Entity Picture	New Value		Type	Variable Name	Entity Picture	New Value
1	Variable	TE1A	Picture.Report	$m.A * C.A * (Tm.A - Temp.A) + m.A * L.A$	1	Variable	TE1C	Picture.Report	$m.C * C.C * (Tm.C - Temp.C) + m.C * L.C$
2	Variable	AE1A	Picture.Report	$TE1A * 0.4$	2	Variable	AE1C	Picture.Report	$TE1C * 0.8$
3	Variable	IE1A	Picture.Report	$IEzone1.A / Tp.A$	3	Variable	IE1C	Picture.Report	$IEzone1.C / Tp.C$
4	Entity Picture	Variable 4	Picture.Widgets	1	4	Entity Picture	Variable 4	Picture.Widgets	1

c) Assignments of variables for Process 1 for Product A (top) and Product C (bottom).

Figure 11.6: Overview of the data assignments for Process 1 within Arena™

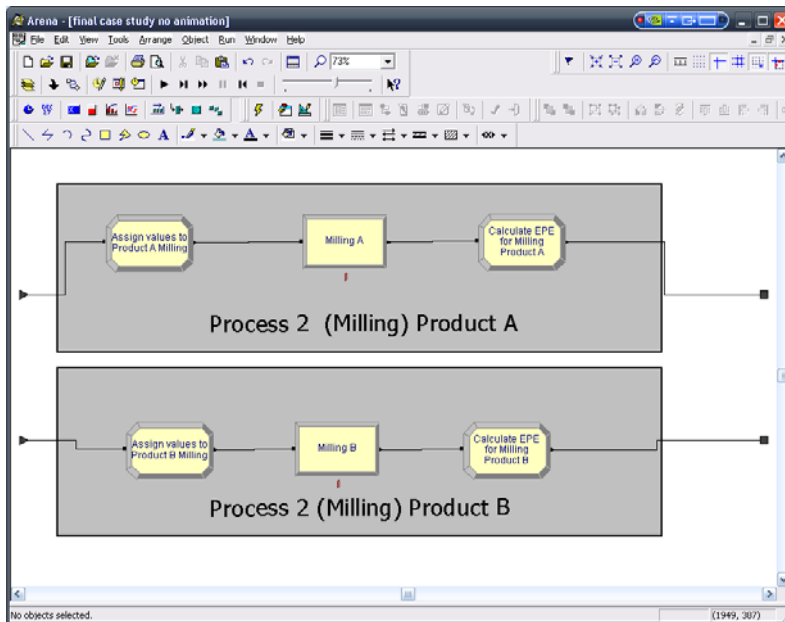

a) Submodel for Process 2 showing the flow of Product A and Product B.

Assignments			
	Type	Attribute Name	New Value
1	Attribute	U.A2	5.6
2	Attribute	V.A2	11510
3	Attribute	Tp2.A	30
4	Attribute	IEzone2.A	1988

Assignments			
	Type	Attribute Name	New Value
1	Attribute	U.B2	5.6
2	Attribute	V.B2	29870
3	Attribute	Tp2.B	25
4	Attribute	IEzone2.B	1988

b) Assignments of part attributes for Process 2. The windows show the values for Product A (left) and Product B (right).

Assignments				
	Type	Variable Name	Entity Picture	New Value
1	Variable	TE2A	Picture.Report	$U.A2 * V.A2 / 1000$
2	Variable	AE2A	Picture.Report	$TE2A * 3.5$
3	Variable	IE2A	Picture.Report	$IEzone2.A / Tp2.A$
4	Entity Picture	Variable 4	Picture.Widget	1

Assignments				
	Type	Variable Name	Entity Picture	New Value
1	Variable	TE2B	Picture.Report	$U.B2 * V.B2 / 1000$
2	Variable	AE2B	Picture.Report	$TE2B * 2$
3	Variable	IE2B	Picture.Report	$IEzone2.B / Tp2.B * 0.5$
4	Entity Picture	Variable 4	Picture.Widget	1

c) Assignments of variables for Process 2 for Product A (top) and Product B (bottom).

Figure 11.7: Overview of the data assignments for Process 2 within Arena™

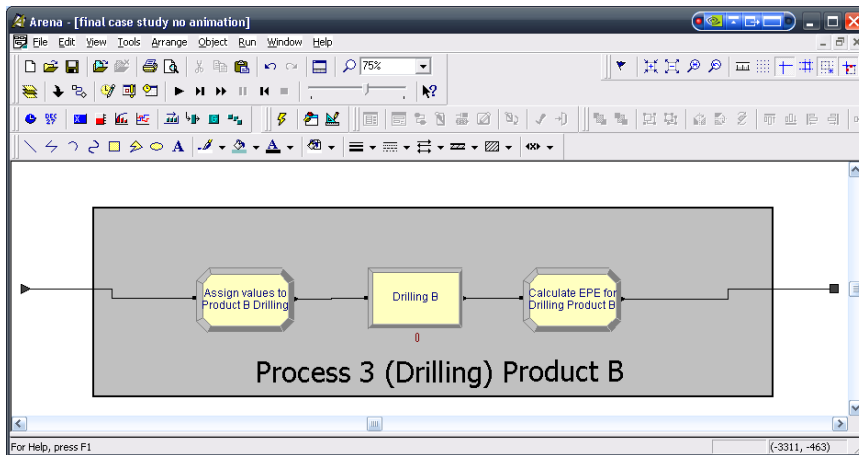

b) Submodel for Process 3 showing the flow of Product B.

	Type	Attribute Name	New Value
1	Attribute	U.B3	5.6
2	Attribute	V.B3	8965
3	Attribute	Tp2.B	25
4	Attribute	IEzone2.B	1988

c) Assignments of part attributes for Process 3 for Product B

	Type	Variable	Entity Picture	New Value
1	Variable	TE3B	Picture.Report	$U.B3 * V.B3 / 1000$
2	Variable	AE3B	Picture.Report	$TE3B * 2.2$
3	Variable	IE3B	Picture.Report	$IEzone2.B / Tp2.B * 0.5$
4	Entity Picture	Variable	Picture.Widget	1

a) Assignments of variables for Process 3 for Product B.

Figure 11.8: Overview of the data assignments for Process 3 within Arena™

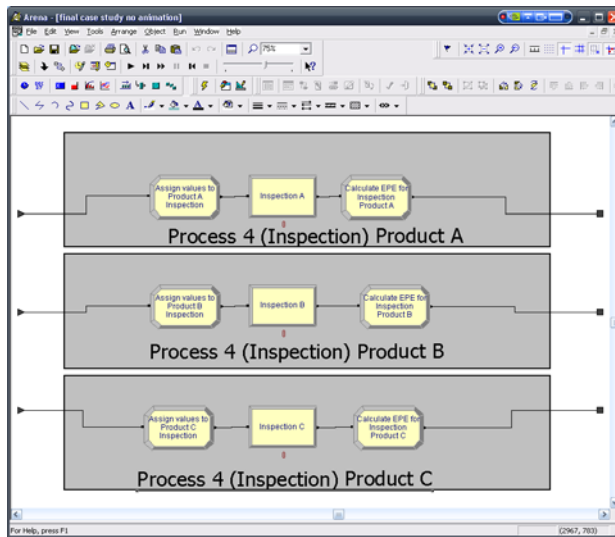

c) Submodel for Process 4 showing the flow of Product A and Product B.

	Type	Attribute Name	New Value
1	Attribute	N.A	8
2	Attribute	P.A	10
3	Attribute	t.A	12
4	Attribute	tp3.A	90
5	Attribute	IEzone3.A	1500

	Type	Attribute Name	New Value
1	Attribute	N.B	8
2	Attribute	P.B	10
3	Attribute	t.B	6
4	Attribute	tp3.B	100
5	Attribute	IEzone3.B	1500

	Type	Attribute Name	New Value
1	Attribute	N.C	8
2	Attribute	P.C	10
3	Attribute	t.C	18
4	Attribute	tp3.C	60
5	Attribute	IEzone3.C	1500

d) Assignments of part attributes for Process 4. The windows show the values for Product A (top left), Product B (top right) and Product C (bottom centre).

	Type	Variable	Entity Picture	New Value
1	Variable	TE4A	Picture.Report	$(N.A * P.A * t.A) / 1000$
2	Variable	AE4A	Picture.Report	$TE4A * 3$
3	Variable	IE4A	Picture.Report	$IEzone3.A / tp3.A$
4	Entity Picture	Variable	Picture.Widget	1

	Type	Variable	Entity Picture	New Value
1	Variable	TE4B	Picture.Report	$(N.B * P.B * t.B) / 1000$
2	Variable	AE4B	Picture.Report	$TE4B * 3$
3	Variable	IE4B	Picture.Report	$IEzone3.B / tp3.B$
4	Entity Picture	Variable	Picture.Widget	1

	Type	Variable	Entity Picture	New Value
1	Variable	TE4C	Picture.Report	$(N.C * P.C * t.C) / 1000$
2	Variable	AE4C	Picture.Report	$TE4C * 3$
3	Variable	IE4C	Picture.Report	$IEzone3.C / tp3.C$
4	Entity Picture	Variable	Picture.Widget	1

c) Assignments of variables for Process 4. The windows show the values for Product A (top right), Product B (top left) and Product C (bottom centre)

Figure 11.9: Overview of the data assignments for Process 4 within Arena™

Once the attributes and the variables have been assigned and calculated, the generic equations for summing the individual energy components (i.e. TE, AE and IE) from each process are assigned within a separate module to establish the Product's total TE, AE, IE and EPE. The efficiency ratios are also assigned in the same manner using the equations discussed in Chapter 8 in a separate module as shown in Figure 11.10. A set of detailed energy data is exported to Excel using the 'write' modules (see Figure 11.11) during the simulation run where the data is further evaluated and presented in the form of graphical charts as shown in Figure 11.12. The overall TE, AE, IE as well as the final Embodied Product Energy for each product is calculated and displayed under the process flow models after the simulation run is complete as seen in Figure 11.13.

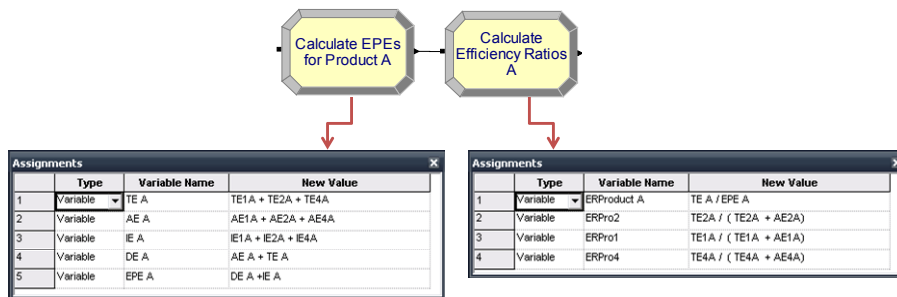

Figure 11.10: The 'Assign' modules and the respective data inputs to calculate the EPEs (left) and the Efficiency ratios (right) for Product A

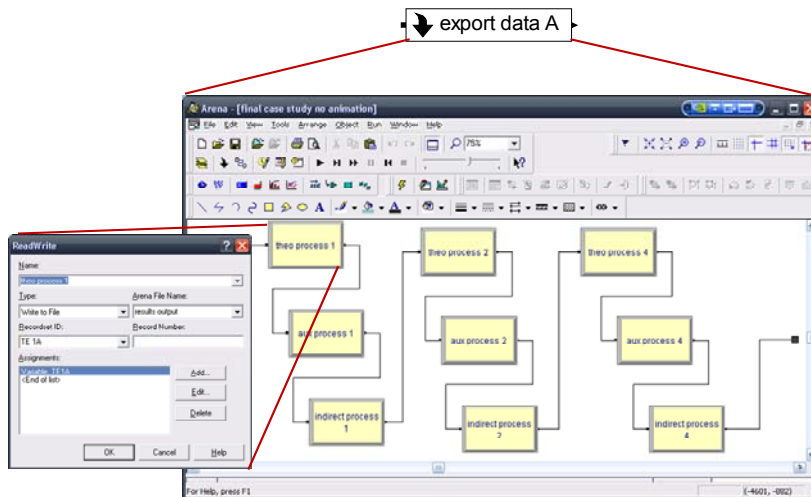

Figure 11.11: The detailed energy information is exported to Excel through the use of the 'Read/Write' module and is created within a submodel. The screenprint shows the submodel for exporting energy data for Product A. The inset shows the settings for the export of the TE (Process 1) for Product A



Figure 11.12: Graphical outputs of exported data within Excel. The final EPE and ER results for the three products are displayed within a single worksheet (left). The detailed energy breakdown for each process is displayed within individual worksheets (right)

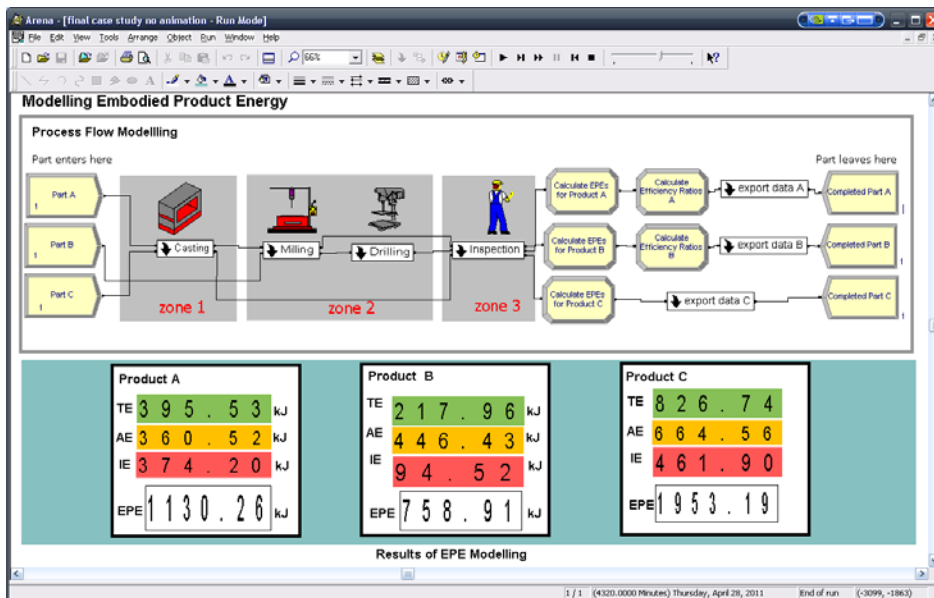

Figure 11.13: Overview of simulation model within Arena™ showing showing the process flow, the modules used for the calculation of the energy values, submodules that export the detailed energy and the embodied energy results Product A, B and C

11.4.3 Results of Case Study 2

11.4.3.1 Results for Product A

The results produced by the ESM for Product A are summarised in Figure 11.14. and Figure 11.15. The total Embodied Product Energy for Product A is 1130.26 kJ, where Process 1 consumed 753.43 kJ, Process 2 consumed 356.32 kJ and Process 3 consumed 20.51 kJ. The $ER_{process(n)}$ are 0.71 for Process 1, 0.22 for Process 2 and 0.25 for Process 4. Overall the breakdown of the energy consumed by TE, AE and IE were evenly distributed with TE accounting for 35%, followed by the IE at 33% and the AE at 32%.

As for the efficiency ratios, the $ER_{product}$ is 0.35, $ER_{process}$ is 0.52, and the ER_{plant} is 0.67 for Product A. A traffic light system has been incorporated in this ESM to provide an immediate visual impact on the efficiencies of the product, process and plant. In this system, the efficiency rates between 0 – 0.32 are represented by a red diamond, the rates between 0.33 – 0.66 are represented by a yellow triangular symbol and finally the rates between 0.67 – 1 are indicated by a green circular symbol. The use of different shapes in this traffic light system enables the effective use of the system in black and white printouts. In the case of Product A, $ER_{product}$ (0.35) is a yellow triangle, $ER_{process}$ (0.52) is also a yellow triangle, and finally ER_{plant} (0.67) is a green circle.

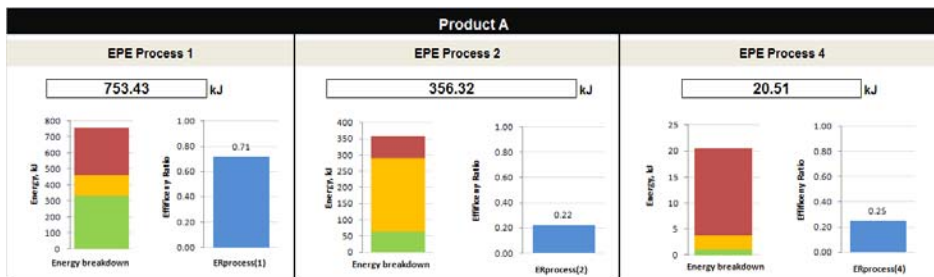

Figure 11.14: Graphs showing the EPE for Process 1, 2 and 4 used in the manufacture of Product A

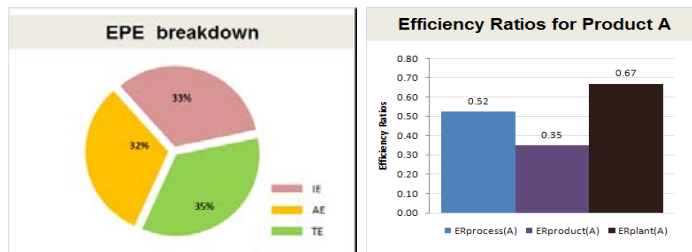

Figure 11.15: Graphs showing the EPE breakdown of Product A (left) and the various efficiency ratios for Product A (right)

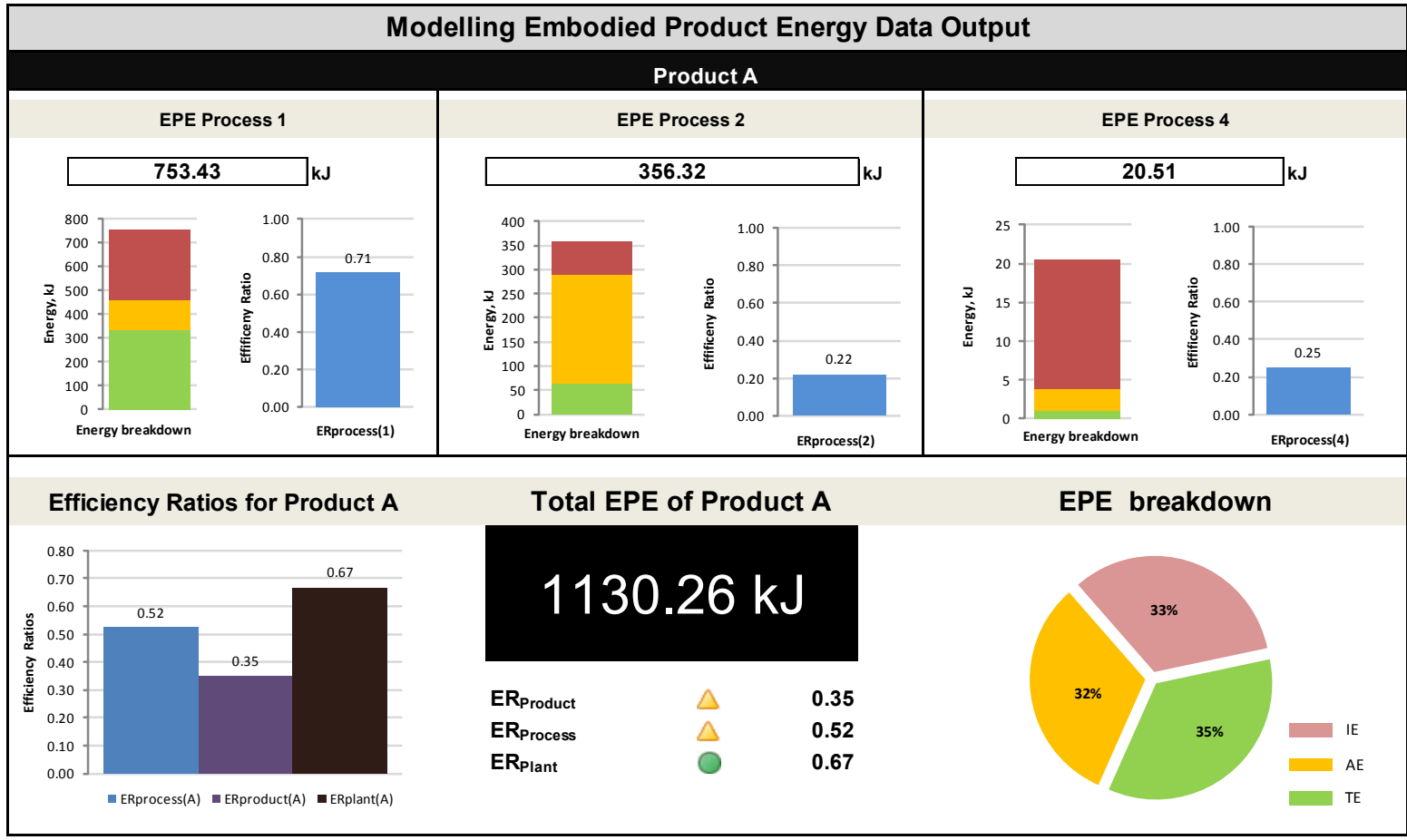

Figure 11.16: Overview of results for Product A

11.4.3.2 Results for Product B

Similarly, the results produced by the ESM for Product B are summarised in Figure 11.17 and Figure 11.18. The total Embodied Product Energy for Product B is 758.91 kJ, where Process 2 consumed 541.58 kJ, Process 3 consumed 200.41 kJ and Process 4 consumed 16.92 kJ. The $ER_{process(n)}$ are 0.33 for Process 2, 0.31 for Process 3 and 0.25 for Process 4.

Overall the AE accounted for the largest proportion of EPE at 59% followed by the TE at 29% and the IE at 12%. As for the efficiency ratios, the $ER_{product}$ is 0.29, $ER_{process}$ is 0.33, and the ER_{plant} is 0.88 for Product B and therefore these are represented by a red diamond, yellow triangle and green circle respectively as illustrated in Figure 11.19.

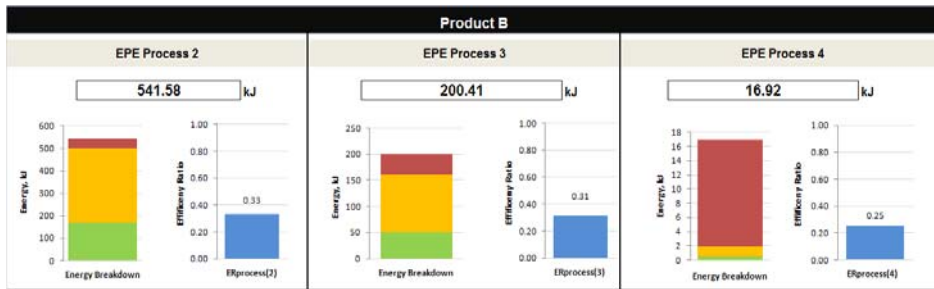

Figure 11.17: Graphs showing the EPE for Process 2, 3 and 4 used in the manufacture of Product B

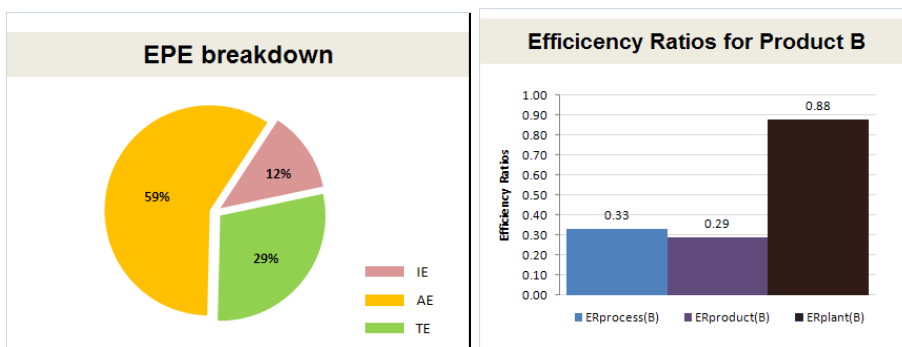

Figure 11.18: Graphs showing the EPE breakdown of Product B (left) and the various efficiency ratios for Product B (right)

Modelling Embodied Product Energy Data Output

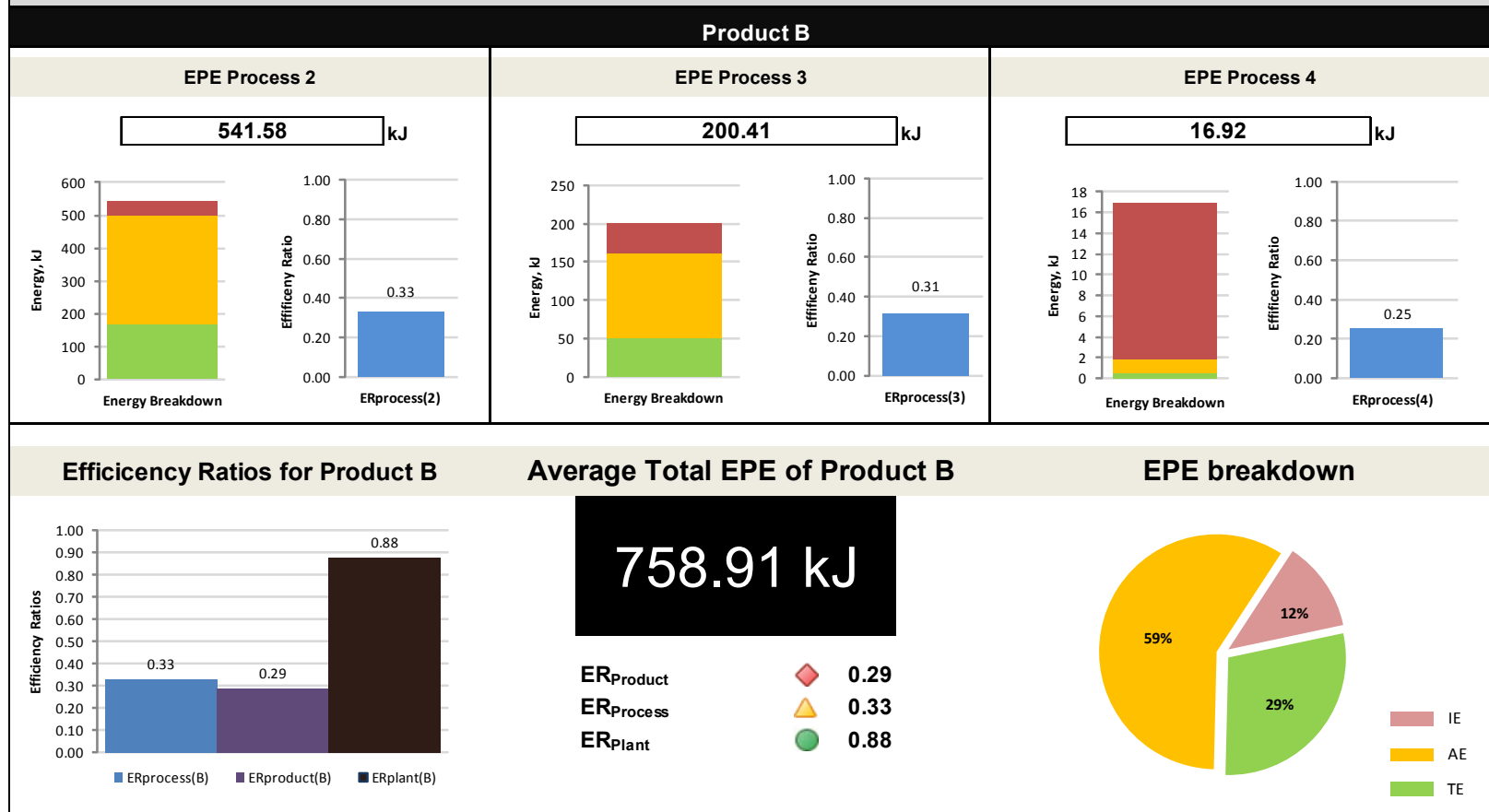

Figure 11.19: Overview of results for Product B

11.4.3.3 Results for Product C

Like the previous products, the results produced by the ESM for Product C are summarised in Figure 11.20 and Figure 11.21. The total Embodied Product Energy for Product C is 1953.19 kJ. Process 1 consumed 1922.43 kJ, Process 4 consumed 30.76 kJ. The $ER_{process(n)}$ are 0.56 for Process 1 and 0.25 for Process 4.

Overall the TE accounted for the largest proportion of EPE at 42% followed by the AE at 34% and the IE at 24%. As for the efficiency ratios, $ER_{product}$ is 0.42, the $ER_{process}$ is 0.40 and the ER_{plant} is 0.76 for Product C and are represented by two yellow triangles and one green circle as depicted Figure 11.22.

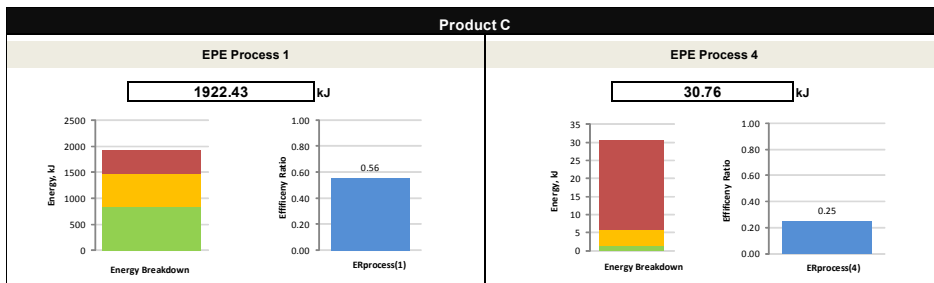

Figure 11.20: Graphs showing the EPE for Process 1 and 4 used in the manufacture of Product C

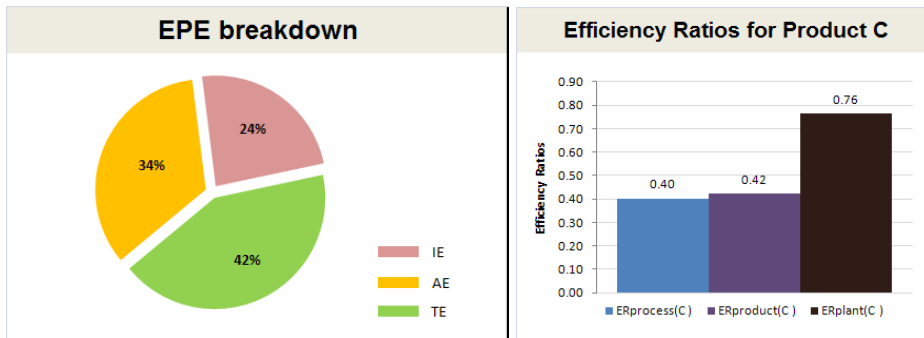

Figure 11.21: Graphs showing the EPE breakdown of Product C (left) and the various efficiency ratios for Product C (right)

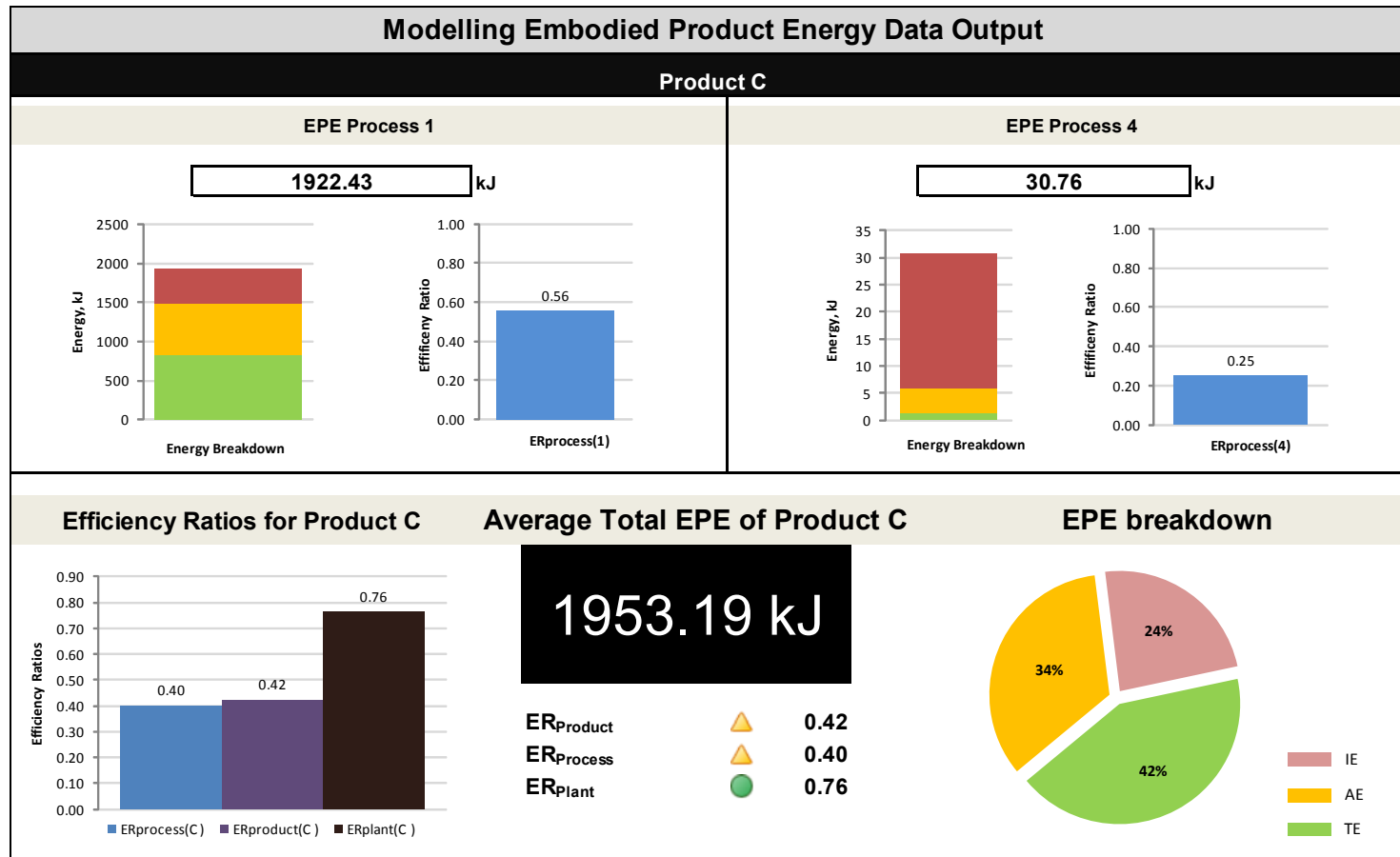

Figure 11.22: Overview of results for Product C

11.4.4 Analysis of the Results for Case Study 2

As outlined in Chapter 8, a number of simple but useful energy efficiency ratios have been defined to determine the productivity of the individual process, production system as well as the overall efficiency in relation to a product. In general, the $ER_{process}$ can be used to assess the inefficiencies introduced through non-productive auxiliary energy, the $ER_{production}$ can be indicative of the inefficiencies through the indirect energy and finally the $ER_{product}$ highlights both the inefficiencies caused by the auxiliary and indirect energy.

Product C is the most energy intensive to manufacture of the three products, with a total of 1953.19 kJ. Despite having the highest embodied energy, when compared with the other two products, the product efficiency ratio indicates that Product C ($ER_{product} = 0.42$) was manufactured most efficiently. However, the $ER_{product}$ is still relatively low and the overall energy breakdown shows that there is scope for energy reduction in the AE and the IE. The detailed breakdown per process shows that Process 1 which is the casting process accounts for majority of the energy consumption for Product C and energy improvements can be made to the auxiliary activities such as maintaining the temperature of the molten metal, sand preparation, materials handling and moulding and core making.

In contrast, Product B required the least amount of energy to manufacture (758.01 kJ) but had the lowest $ER_{product}$ ratio of 0.29. This indicates that although a relatively small amount of energy was embodied in Product B, much of the energy was required for non-productive activities and services as represented by the high proportion of AE (59%). Product B also has the lowest $ER_{process}$ ratio at 0.33, which suggests that most of the energy consumed by the production processes is due to the auxiliary processes. A closer examination of the energy results shows that all three processes (i.e. processes 2, 3 and 4) have low individual $ER_{process(n)}$ ratios (all lower than 0.35). The graphs showing the energy breakdown on the processes indicate that a large proportion of auxiliary energy is consumed by the milling and drilling processes. These two processes could be a starting point for energy improvements to minimise the inefficiencies associated with Product B. Potential energy improvements for machining processes include looking at operational set up to minimise idle time, which is achieved through high speed loading and unloading of systems or reducing set up times of work pieces and/or preloading of

cutting tools. Other improvements can include optimising the auxiliary processes like the coolant and lubricant pumps by installing variable motors or by applying an inverter motor and accumulator.

Product B may have the lowest process efficiencies, but it has the best production efficiency as established by the ER_{plant} ratio. It has the highest score at 0.88 whilst Product A is the lowest at 0.67. A closer look at the energy results for Product A indicates that Process 1 (Casting) accounts for majority of the indirect energy consumption. Product C also requires the casting process for its manufacture and energy breakdown shows that a significant amount of indirect energy has also been consumed. Therefore the building services associated with casting could be highlighted as the main priority for improvement and optimisation so as to reduce facility energy consumption.

One of the other outputs generated by the ESM in cases where there are multiple products (or a multiple production system) are being modelled is a summary result sheet as shown in Figure 11.23. A comparison of the various ratios between the products as well as a breakdown of the embodied energy for each product by process is included in this summary result sheet. The summary sheet also shows the overall EPE as well the overall TE, AE and IE breakdown for each product. The efficiency ratios are also plotted against the three products. This allows for a quick comparison between products and clearly highlights the product that is the least or most efficient during the production phase.

11.4.5 Using the Results to support Design for Energy Minimisation

Overall the results indicate that Product C not only embodied the largest amount of energy, but also embodied the largest amount of non-productive energy from auxiliary and indirect energy sources at 1126.46 kJ as compared with 734.36 kJ for Product A and 540.95 kJ for Product B. Therefore, Product C is selected to illustrate the use of the decision support matrix proposed as part of the Design for Energy Minimisation methodology as previously described in Chapter 10, a list of possible energy improvements to the manufacturing operations for Product C will be evaluated against the design specification to determine the improvements that can be effected through design changes.



Results Output Summary Sheet



ERproduct, Product Efficiency Ratio $0 < ER_{product} < 1$

Ratio of the energy theoretically required to manufacture the product against actual amount of energy used.

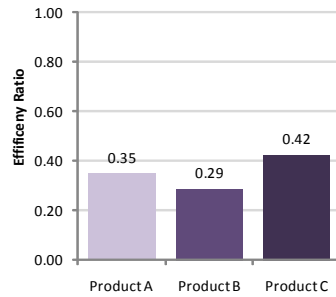

Breakdown of Energy Consumption by Product

A breakdown of the energy consumed per product based on the Indirect Energy, Auxiliary Energy and Theoretical Energy.

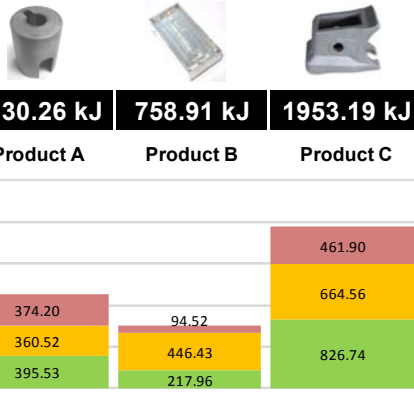

ERplant, Plant Efficiency Ratio $0 < ER_{plant} < 1$

Ratio of the direct energy required to manufacture the product against actual amount of energy used within a production

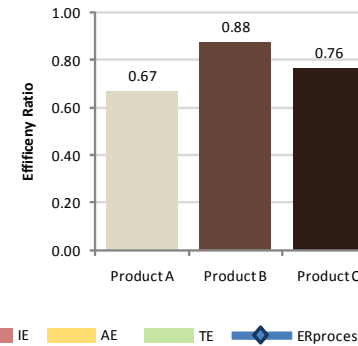

Breakdown of Energy Consumption by Product

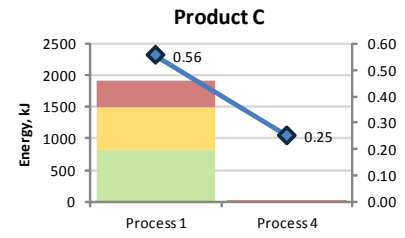
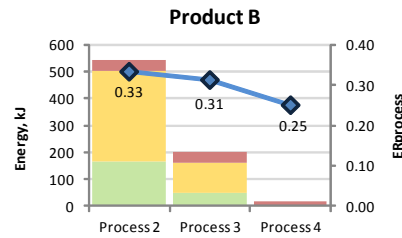
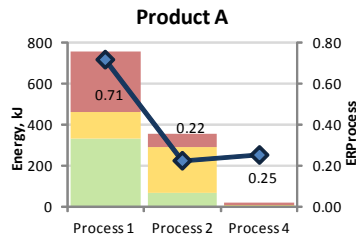

Figure 11.23: Overview of results for Products A, B and C.

A high level list of improvements to the processing parameters and manufacturing operations is compiled based on the casting process. Some of the recommendations for improvements include:

- a) Reduce casting weight
- b) Improvements the gating system,
- c) Reducing the complexity of cores and mould
- d) Reduce scrap rates
- e) Increase throughput
- f) Improve fume extraction

The recommendations are grouped based on the energy component they can impact (e.g. reduction of casting weight) impacts the TE required by the process. A list of common design specifications such as aesthetics, performance, size etc. is listed on the left column in the HOQ matrix depicted in Figure 11.24 which shows the full list of recommendations and the design specifications.

The recommendations are compared against the design specifications for correlations. Reduction of the casting weight will affect the aesthetics, performance, size, weight and possibly the standard specifications; therefore they are given a '1'. Those that have no correlations are given a '0'. Based on this approach, the 'Reduce casting weight' and 'Reduce complexity of cores and moulds' both have a relatively high number of correlations of 6 and 4 respectively. These two areas provide a starting point for designers to re-evaluate the design of the product to further reduce the embodied energy from the manufacturing process. As the TE was the largest contributor to the embodied product energy for Product C, reducing the TE has been prioritised first, follow by the AE, and the IE. Therefore, the design engineer might first choose to reduce the weight of the casting by redesigning the part to have thinner walls or eliminating certain features. If the design changes cannot be fulfilled the engineer can then consider the next priority which is the reduction of core and mould complexity. This can be done by simplifying the internal geometry of the part so that number of holes and undercuts are minimised thus requiring less processing during the fabrication of the cores and moulds, thereby reducing the amount of auxiliary energy required during manufacture. The reduction of casting weight can complement the reduction of core and mould complexity as indicated by the '+' at the top of the HOQ matrix. In addition, the

reduction of casting weight and the simplification of the cores and moulds may result in faster processing times, and hence increase the throughput which in turn reduces the need for indirect energy consumption. A comprehensive list of other processing interdependencies are shown in Figure 11.24.

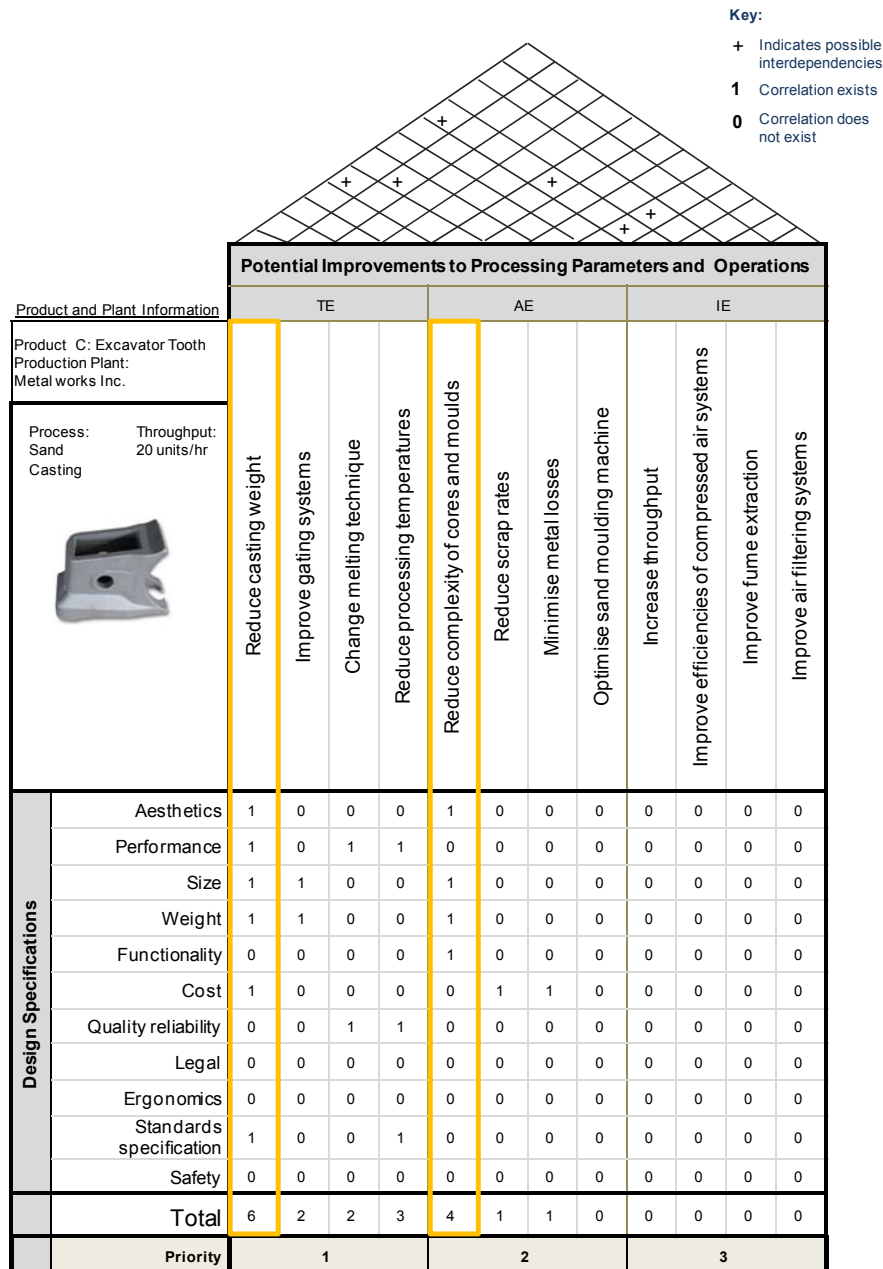

Figure 11.24: Decision support matrix for the DfEM process used for the casting process for Product C

11.5 General Outcomes from the Case Studies

The case studies described in this chapter have effectively demonstrated the applicability of the Embodied Product Energy (EPE) framework, its associated energy simulation model and the 'Design for Energy Minimisation' support tool as developed as developed by this research.

In the first case study, the single product (elbow pipe) demonstrated that the various energy components established as part of the EPE framework can not only highlight how much energy was used, but also how productively it has been used; demonstrating that the most energy intensive processes may not necessarily be the least energy productive process as verified by the energy ratios.

In the second case study, the EPE framework can be integrated with a simulation model to aid the analyst when dealing with numerous products with different process flows. As shown, the model provides a high degree of customisation with the flexibility for various sources of data to be entered and for various correlations to be established within the simulation model.

Undertaking these case studies have shown that even with the help of simulation software, it is a data intensive process. As such, the integration of the ESM with appropriate databases would potentially provide greater benefits. The energy simulation model can also be further improved by linking detailed product and process data from the production system being analysed, thus improving the accuracy and relevance of the resulting embodied energy values. These case studies have also shown that the DfEM approach provides valuable decision support enabling further design improvements to minimise the energy consumption within a manufacturing system.

Overall the case studies have demonstrated the effectiveness of energy flow modelling approach generated by this research to provide greater transparency of energy consumption during the production phase of a product. In addition, the flexibility offered by ESM enables a wider range of results tailored to the specific needs of various potential users within a manufacturing facility (e.g. operators, production planners, shop floor maintenance and designers) to be generated.

Chapter 12 Concluding Discussions

12.1 Introduction

The discussion provided by this chapter brings together the major issues examined by this research and reports on the research contribution provided in this thesis. The first part of the chapter highlights the main research contributions, while the latter part presents a discussion based on the broad headings identified as the research scope in Chapter 2, to highlight the key findings and knowledge gained from the research.

12.2 Research Contributions and Achievements

The author has identified the following as the important contributions made by this research and have ranked and listed them by importance below:

Comment [Y13]: Rank contributions

- i. Generation of a new approach for energy flow modelling in manufacturing applications based on a product viewpoint. This novel approach, integrates the existing methods for optimisation at process and plant perspectives to highlight the energy ‘hotspots’ during a product lifecycle, thus providing support for prioritisation of investment and energy optimisation activities.
- ii. Development of a novel and comprehensive energy flow modelling framework based on the identification of different energy consumers in a production system to highlight energy intensive processes and activities present in the manufacture of a product. Through the framework, the DE provides an indication of the energy required by the resources to carry out the process use to make the product and the IE is indicative of the energy consumed by the facility. This method provides a systematic way of establishing the energy required to manufacture a product thus providing answers to the first and second research question “of the total energy consumed to manufacture a product, how much of the energy is used directly by the process” and “how much is used by the facility that houses the process and other supporting processes?”

- iii. Design and implementation of a novel energy simulation model to measure the energy embodied in a product which assesses the energy efficiency of the product, processes and plant in support of manufacturing and design improvement decisions.
- iv. The research has shown how design decisions can influence the energy required to manufacture a product and through the definition of a novel 'Design for Energy Minimisation' methodology, it has provides support in minimising energy consumption over a product life cycle through improvement in product design, by systematically applying appropriate energy modelling tools at each stage of the design process. Several key design factors that impact energy consumed during manufacture have also been compiled and the impact on energy consumption during manufacture explained. Some of the design factors to consider include the use of minimal wall thickness, the use of alternative materials that require less energy for processing, designing features so they can be manufactured using the minimum number of set ups and with minimal number of processes.
- v. The research has defined a new approach to attributing energy consumed by the infrastructure (Indirect Energy) through the use of zones to product throughput. The approach groups areas with similar ambient requirements into zones and the average energy consumption for the zone over a fixed period of time is then averaged to the number of products being made in that area over the same time frame. This provides a greater understanding of indirect energy consumption and allows the energy consumed by the facility to be allocated to the product thus answering the research question "when considering the energy consumed by the facility that houses the process how can it be attributed to the manufacture of a unit product?".
- vi. Highlighting the paramount importance of energy rationalisation and optimisation within manufacturing industry and underpinning the imperative point that investment in green sources of power generation alone are insufficient to deal with the rapid rise in energy demand in the near future.

12.3 Concluding Discussion

The following subsections draw together and discuss the results of the main research activities and use the research scope to structure the evaluation of research achievements.

12.3.1 Review of the sources of power generation and various trends in energy consumption within the industrial sector

To establish the context for the research, an extensive review was conducted on a wide range of issues ranging from sources of power generation to energy related legislation and their implications for the manufacturing industry. This research has highlighted that the rationalisation and optimisation of energy use is of paramount importance for manufacturers in light of escalating environmental, economical and legislative pressures. The concern over the use of energy has been exacerbated by the compelling body of evidence showing the rise in global temperature is very likely the result of the increase in greenhouse gas emissions which has been largely due to the industrial scale combustion of fossil based energy. The problem is further compounded, in part, by the growing energy demand from developing countries as they attempt to meet the energy requirements for their economic and industrial growth through the relatively low cost energy generated by fossil fuels. Much of the demand for fossil based fuel is due to the industrial activities which accounts for more than a third of global energy consumption. Against this backdrop, it is imperative that the manufacturing industry adopts the concept of 'lean energy' through the use of energy efficient processes and activities, in order to not only meet stringent legislative targets but more importantly minimise financial risk from volatile energy prices whilst maintaining production outputs. The consideration of these issues highlights the requirement for greater transparency of energy use within a production system so as to provide manufacturers with a clearer understanding of energy consumption and efficiencies of their processes and activities. This has been the main justification for this work and has significantly influenced the definition of the objectives of this research.

12.3.2 Review of energy management and modelling research, tools and software

The second part of the literature review highlighted two main categories of energy related research, i.e. those based on manufacturing system and those based on product life cycle. The review of research on energy considerations within a manufacturing system has identified different approaches for energy evaluation and analysis. The majority of this existing research is based on facility perspective improvements (through better building design and infrastructure services) and process energy improvements (through operational and production set-ups). While these tools allow the improvement of energy consumption within a plant and process, they do not provide an indication of the energy requirements attributable to a product, and less so over its life cycle. The second category of energy research is based on considerations of various stages in product life cycle, often through a life cycle assessment exercise. However, the literature review has highlighted that LCA is often complex and data intensive, and the attempts at simplifying the method often lead to assumptions that can affect the relevance of the results for a specific application. Moreover, the energy analyses conducted within LCA are often based on a 'constant per mass' basis which fails to consider the complexity of operations required to manufacture a product and the impact that such varying complexities of operations has on energy consumption.

As such the literature review has identified a gap in the existing approaches for modelling energy flows within a production system based on a product view that could highlight the energy hotspots during a product life cycle and can account for the complexities of production operations required to manufacture a product. The research presented in this thesis addresses this shortfall in energy assessment capability.

This disparity was also reflected in the review of commercial tools. Commercially available LCA software packages use generic energy data and are limited in dynamic modelling capabilities. As such, it is difficult to identify energy inefficiencies within current software packages in relation to the manufacture of a product and the improvements needed in operational parameters. The review thus highlighted the need to produce an energy modelling tool, such as the energy simulation model proposed in this research to support the modelling and rationalisation of energy consumption during the manufacture of a product, enabling energy optimisation both within production activities and product design.

12.3.3 Development of a framework to model embodied product energy

In the initial part of the research, it became apparent that there was a wide range of energy considerations within a manufacturing system that need to be identified and assigned to production processes. Therefore, a simple but holistic energy flow modelling framework based on two main categories of energy consuming activities has been developed, namely direct energy and indirect energy. The direct energy encompasses the energy consumed by the processes and activities involved in the transformation of material into the finished product, taking into account both the theoretical and auxiliary energy required; and the indirect energy encompasses the energy consumed by services required to maintain the environment in which the transformational processes occur. In addition, the method of attributing indirect energy by zones based on the energy intensity of the production environment provides a greater simplicity and accuracy over other approaches that are based on averaging energy use over production output or attribution of energy consumption based on area/volume occupied by the machinery and equipment.

From the literature review, it was noted that detailed data related to energy consumption within manufacturing facilities is often lacking and the research recognises that there may be occasions where directly obtaining this data through monitoring and metering maybe infeasible. Therefore as part of the framework, the research also established three methods of systematically obtaining, calculating and measuring energy data for processes and supporting activities within a manufacturing system through theoretical and/or empirical studies or through existing and relevant databases.

Furthermore, the energy efficiency ratios developed in this research provide a simple but effective method of assessing the energy productivity within a manufacturing system. TE, AE and IE values are used in these ratios to identify inefficient processes, products or production systems, and can play a fundamental role in determining where investments should be made for further energy improvements and energy optimisation.

In addition, there has been an increase in the number of environmental labels that have been applied within the manufacturing sector in recent years. For example, labels such as the EU Energy label and the US Energy Star have provided consumers of electrical and electronic products with energy information about the performance of the product, which has empowered consumers to select products with higher energy efficiencies.

This on other hand has forced manufacturers to improve the energy efficiencies of their products in order to remain competitive. The academic and industrial communities together with policy makers have also highlighted the need to establish similar energy efficiency labels for machinery and production systems used within a typical manufacturing facility. Thus, energy management standards such as ISO 50001 (ISO, 2010) have been implemented to help manufacturers monitor and reduce energy consumption within their facilities. The energy efficiency ratios introduced by this research provide a platform for further investigation in establishing such energy labels not only for production plants and processes but also allows the scope of current product based energy labels to be expanded from the ‘use’ phase to consideration of the entire lifecycle.

The author asserts that the use of the energy modelling framework, alongside the efficiency ratios can provide a greater level of transparency of energy consumption within the production phase of a product life cycle, yet simplifying the complexities associated with traditional life cycle assessment methods.

12.3.4 Development of an energy simulation model to support energy efficiency optimisation

The implementation of the energy flow modelling framework within a complex product clearly needs software support in order to deal with the large amount of data required for a range of processes that need to be modelled. The use of simulation techniques enables a hierarchical multi-level modelling approach to be adopted. i.e. each process or event within the model could represent a supplier across a supply chain, a department within a factory, a production line within a manufacturing cell, or even a range of activities within a single production process. The level of detail included in a simulation depends on the resolution of the model required and the availability of the data.

The development of the energy simulation model has also addressed the primary research question which was defined as “How much energy is required to manufacture a unit product?” Therefore it is argued that a carefully developed energy simulation model which provides a detailed representation of the manufacturing system can be used to estimate the energy required for new product designs.

Although the model has been set up to replicate existing processing lines and equipment, the author believes that the utilisation of the energy simulation model provides the flexibility for predicting the effectiveness and impact of process improvements before committing to a large investment.

12.3.5 Use of the energy simulation model to improve product design

The Design for Energy Minimisation methodology, together with the simulation tool presented in this thesis, enables designers to do ‘what-if’ scenario planning to identify the most practical and economically feasible design improvements that can reduce the need for energy consumption during manufacture. In addition to supporting operational decisions, the modelling of Embodied Product Energy provides energy transparency right back to the design process, enabling designers to select the most energy efficient materials and processes whilst fulfilling the requirements of the product design specification. Such an approach will potentially enable businesses to go beyond the incremental improvements achievable via existing energy management systems, and enable them to consider energy efficiency and utilisation across both the design and production phases of a product life cycle.

The author recognises that a holistic DfEM approach should consider the full design process from conceptual design through to detail design and manufacture, whilst also considering the energy consumption throughout the entire product life cycle (material, production, use and end-of-life). The existing streamlined LCA tools mostly provide support during the concept design stage by providing high level energy information of each phase of a product’s life cycle whilst Advanced Energy Metering Systems provides support at the production phase through the monitoring and tracking of energy consumption within the manufacturing facility. This has highlighted a need for a tool to support the designers at the detail design stage and can generate energy data based on a range of proposed production processes and operational parameters. The Energy Simulation Model developed as part of this research bridges the gap between the high level streamlined LCA tools used at conceptual design and those used to monitor and manage energy consumption as part of the manufacture stage of the design process. This ensures that the energy considerations are included within various design decisions and incorporated within the entire design process.

12.3.6 Demonstration and validation of the applicability of the research concept

The primary objective of the case studies presented in this thesis was to demonstrate and validate the applicability of the research concepts. The purpose of the first case study was to show the application of the framework together with the range of calculations involved in generating a detailed breakdown of energy consumption using a simple product. Whereas, the second case study was to demonstrate an example of a more complex multi product flows within a manufacturing system, using the energy simulation model.

The first case study shows that various energy values related to direct and indirect energy can be calculated using the equations provided as part of the EPE framework. Whilst it is possible to calculate these values manually in the case of a simple product, this case study also highlights that in the case of more complex products involving a wide range of production processes (possibly within a number of suppliers in a supply chain) a software support is imperative for implementation of EPE framework. The second case study illustrated the effective use of such software support through implementation of an energy simulation model.

The second case study also demonstrated the benefits of integrating the energy considerations at the facility and process perspectives (within a product viewpoint) to identify the energy hotspots within a manufacturing system that should be the focus of energy optimisation activities. In addition, the comprehensive graphical capabilities provided by the simulation model underlines the potential for a range of energy analysis that can support a wide range of potential users within a manufacturing business.

Furthermore, the second case study shows the complexities associated with acquiring accurate energy information required for the development of the simulation model.

This emphasises the importance of three key issues:

- 1) The importance of the implementation of advanced metering and monitoring systems to collect actual data for energy consumption,
- 2) The need for integrating the simulation model with other existing manufacturing software for data sharing and analysis, and

- 3) Finally, the requirements for careful design and customisation of such simulation model tailored to the specific requirements of various potential users (e.g. designers, production operators, planners, maintenance managers) within a manufacturing application.

12.3.7 The vision for the future of Energy Efficient Manufacturing

The current emphasis in the majority of large scale public and private investments is currently targeted at the generation of green (renewable) sources of energy. The review and analysis undertaken in this research has clearly highlighted that energy demand is set to rapidly escalate, with predicted demand increasing by 36% between 2035 and 2008 (with oil still being the dominant fuel) according to recent forecasts figures released by the International Energy Agency (IEA, 2010b). This clearly highlights that whilst investments in alternative sources of fuel is essential, in the short term the rationalisation and optimisation of energy use will be of paramount importance and will provide much greater dividends.

The reduction of energy use provides benefits to manufacturers that extend beyond environmental and cost considerations in today's volatile world. The decoupling of energy use and productivity, whilst maintaining the value of products and services is the key to long term sustainability of businesses in the face of tighter legislation on energy consumption. The significant reduction of the dependence on raw materials like oil, coal and gas in an increasingly resource constrained world will safeguard the future prospects of industrial organisations.

This research has developed a holistic approach to the modelling of energy consumption during the manufacture of a product. This approach can help to ensure that products are designed and manufactured with minimal energy use. However, the main domain for this research has been mainly on discrete part manufacture within sectors such as automotive, aeronautical, electrical and electronic etc. However within manufacturing industry, some of the most energy intensive applications are within the process industry (petro-chemical, pharmaceutical, food, etc.) which highlights the need for specific research targeted at this industry.

The fundamental outcome of the author's work has been that the importance of future research on maximising the energy productivity within all manufacturing sectors cannot be underestimated, as failure to do so will have significant repercussions on the survival of business and preservation the environment for future generations.

12.4 Limitations of the Research

The research reported in this thesis has investigated an area which is highly complex and diverse in its scope. Research into modelling energy consumption within a manufacturing system requires further development and lacks standardisation and congruency across industrial sectors. This is further compounded by the general lack of energy data from industry. The scope of the research has therefore focused on the production phase of the product life cycle and the range of case studies undertaken by this research was therefore selected under these constraints. In this context, the limitations of the research are summarised below.

12.4.1 Range and detail of case studies

Some data within the case studies has been estimated based on assumed energy consumptions according to processing parameters. As such some data used within the case studies was based on synthesised data. The assumptions have been detailed within the relevant sections in Chapter 11. Ideally the research could have benefitted from the validation through an industrially based case study in which facility specific data are used for comprehensive energy simulation modelling. This has been identified as one of the scopes for future work based on the research reported in this thesis, as outlined in Chapter13.

12.4.2 Consideration of integration of the software within other existing support systems

The ESM model was developed using Arena, a commonly used software package. However, within a typical manufacturing company other software models may have been developed to simulate a range of other functions (e.g. line balancing, layout planning, production scheduling etc.). The integration of these models within an application to share information could significantly reduce the modelling effort and time. In addition, it is acknowledged that the development of software systems lies outside the author's primary skill-set and as such a more sophisticated model could have

been developed to integrate other features and functionality, such as those highlighted in Chapter 13.

12.4.3 Implication of consideration of other sources of energy other than electricity

Although most of the production equipment described in this thesis and used within the case studies are electrically powered, and no specific reference have been made to the source of energy used. However the EPE framework uses the International System of Units for energy –Joules (J) in all the calculations, and as such the framework is applicable to other sources of energy such as gas, oil and heat which can be easily represented in Joules.

12.4.4 Energy cost and carbon footprint considerations

There are significant differences in the cost of energy in different countries based on technology and fuel available for power generation. At present, the costs of ‘green’ energy generated through renewable sources (e.g. solar, wind and tidal) are typically higher than those from fossil derived sources (e.g. coal, oil and gas). One of the main contributors to this higher cost of ‘green’ energy is the perceived savings from carbon levies due to their lower carbon footprints.

The primary objective of this research has been to minimise the amount of electrical energy used in manufacturing applications. This research has not considered the issues relating to cost and carbon footprint associated to the various sources of power generation.

Chapter 13 Conclusions and Further Work

13.1 Introduction

This chapter identifies the major conclusions drawn from the author's research, and proposes possible avenues for further extension of this work.

13.2 Conclusions from the Research

The conclusions drawn from this research are as follows:

- i. The research has clearly highlighted the importance of the optimisation of energy consumption within manufacturing systems due to commonly reported environmental impact associated with power generation, the recent proliferation of national and international legislations and the rising cost of fuel.
- ii. The survey of current research work on the energy modelling and management tools has shown that these tools are often developed with a focus on energy consumption either through a plant perspective or a process perspective. This indicates a distinct lack of energy flow modelling approaches that integrates energy considerations at both the high (factory) level and the low (machinery and equipment) level which can be attributed to the manufacture of a product within a production system.
- iii. The consideration of current application of energy modelling and energy management in this research has indicated that in most cases there is a lack of good quality energy data being collected and recorded within manufacturing systems. In addition, in applications where significant energy data is being collected through advanced energy metering and management systems, this data is not effectively used to its full potential. This research has introduced a systematic method for collecting energy data through theoretical and/or empirical studies or through existing and relevant databases.

- iv. The research has shown that the lack of energy considerations during ‘product design’ and ‘operational planning’ are often due to the wide ranging decision complexities. This highlights a need for a structured, simple, and effective energy flow modelling within manufacturing systems. The Embodied Product Energy framework developed by this research provides such a simple but holistic framework that can attribute both productive and non-productive energy consuming processes and activities thus increasing the energy transparency and identifying energy hotspots within a production system.
- v. The efficiency ratios proposed as part of the framework provides an effective method of identifying inefficiencies within processes, product or production system which can play a fundamental role in determining where investments should be made for further energy improvements and energy optimisation. Furthermore, a major outcome of this research is the first step towards establishing energy efficiency labels for the processes and production systems, the requirement for which has been highlighted by the academic and industrial practitioners.
- vi. The research has underlined the shortcomings associated with existing manufacturing software to support the energy related decisions, thus the requirement for improved functionality within both design and operational planning activities. The Energy Simulation Model created as part of this research provides such capabilities through correlation between design specifications (material and process selection, feature dimensions, and etc.) manufacturing parameters (e.g. set up times, batch sizing queuing times etc.) and the total energy consumed during the manufacture of a product.
- vii. The research has shown that the design process has fundamental implications in the amount of energy used through a product life cycle and hence significant energy savings is often only feasible through design improvements. The energy flow modelling proposed by this research provides transparency right back to the design process, enabling designers to select the most energy efficient materials and processes whilst fulfilling the requirements of the product specification.
- viii. The design process is a complex multitask activity and any ‘Design for Energy Minimisation’ methodology should include support for energy related decisions at different stages of the design process (concept design, detail design, and

manufacture). The 'Design for Energy Minimisation' approach proposed in this research has integrated a range of tools (including an energy simulation model that specifically supports the requirements within the detail design stage) to enable designers to assimilate energy considerations through all stages of the design process.

- ix. The case studies described in this thesis have effectively demonstrated the applicability of the research concepts. These case studies have also shown the requirements for a significant amount of energy data to be able to develop effective decision support for a wide range of potential users (designers, operations planners, maintenance managers etc.). This on one hand is indicative of the time and effort required to develop a customised energy simulation model tailored to the specific requirements of a manufacturing facility, but on the other hand has clearly highlighted energy optimisation potential that can be achieved through greater insight into the inefficiencies of the processes and associated activities.
- x. The fundamental conclusion drawn from this research is that investments in green sources of power generation alone are insufficient to deal with the rapid rise in energy demand, thus energy optimisation and rationalisation within businesses is of paramount importance for a global, long term, and sustainable energy strategy for the manufacturing industry.

13.3 Further Work

The author recognises the following areas of work as the most valuable extensions of the current research.

13.3.1 Establishment of a comprehensive central energy database

The existing manufacturing energy databases are still limited in the range and the detail of the energy information on manufacturing processes such as documenting correlations between processing parameters and the impact on energy use. This makes the tabulation of production specific energy data especially challenging where such data cannot be obtained directly from the actual process. Therefore further research is needed to develop a comprehensive understanding of the relationships between the various equipment parameters (machine model and condition) and operational procedures (set

up times, idle times etc.) through which a holistic and detailed manufacturing energy consumption database can be established. The provision of such a database would augment the existing understanding of process and operational parameters and their influence on energy use within a process which can support further analysis such as those defined in this thesis. The author appreciates that the establishment of such databases are beyond the means and capabilities of any single organisations, thus highlighting the importance of international collaborative efforts such as CO₂PE and UPLCI in this area.

13.3.2 The Development of a more Sophisticated and Comprehensive Energy Simulation Model

The energy simulation model developed in this research was designed primarily to demonstrate applicability of the EPE framework. The development of an industrial based energy simulation model requires substantial modelling effort and software competency. The improvement on software implementation is required not only to simplify the use of this model for a range of potential users within manufacturing applications, but to also improve the data handling and integration via modules developed using programming languages such as Visual Basic.

The energy flow models included in the EPE framework considers the energy consumption within a single factory. The flexibility offered through both the research concepts included in this framework and modern simulation techniques enables the consideration of energy flow modelling from a broad enterprise level to a focused single process level. The author has envisaged a hierarchical multi level approach to simulating energy flows as depicted in Figure 13.1. In this approach the definitions of models and sub-models similar to those included in Arena, can be used to incorporate as much or as little complexities within an extended enterprise consisting of various suppliers, manufacturers with global production facilities, and the range of functional departments and production cells in their facilities.

These comprehensive models can provide the foundations for benchmarking to ascertain the lowest energy consumption levels that can be consumed. This can be done by using equipment specifications and empirical results available in industry to establish an energy consumption guideline for a range of processes.

Comment [Y14]: Ascertain lowest energy

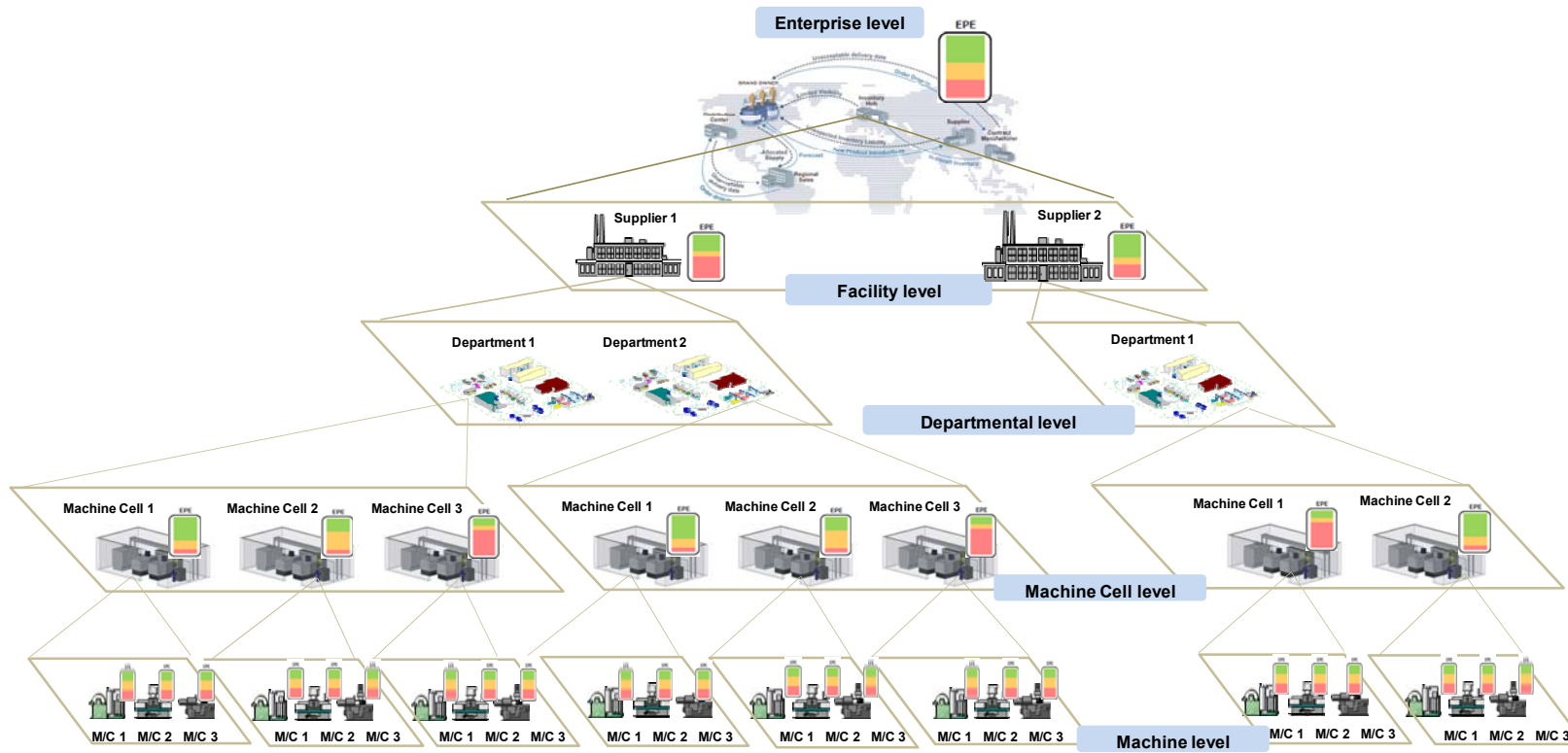

Figure 13.1: Application of EPE framework to other levels through a hierarchical approach

13.3.3 Consideration of Economic Cost Benefits

This research has focused on the amount of energy consumed during the production of a product. A more holistic approach would be to also include cost benefit analysis related to this energy consumption. Therefore the author purports that one of the most important extension to the scope of this research will be the consideration of cost issues and their impact on energy related decision making within manufacturing applications. The consideration of pay back periods is one of the key decision factors in committing any substantial investments for energy rationalisation and optimisation, for most manufacturers.

13.3.4 Extending the Design for Energy Minimisation Approach to other Life Cycle Phases

As with most DFX tools which improves design from just one perspective, DfEM only provides a singular view focusing on energy consumption during production. The reduction of energy consumption in the production phase may have an adverse effect on the other stages of the life cycle. Clearly the scope of this approach has to be extended to consider the energy considerations related to wider issues within a product life cycle such as the energy requirements during the use phase, logistics and reverse logistics and end-of-life. In addition, in current modern applications, the need for reconfigurability of manufacturing facilities due to short product and production lifecycle is well documented. Therefore a modern design approach should consider a simultaneous approach encompassing design considerations of the products, processes to manufacture the products and production systems in which these processes are incorporated. Therefore an extension of research scope is proposed based on the multi design viewpoints, as illustrated in Figure 13.2, to include simultaneous considerations for product, process and production design.

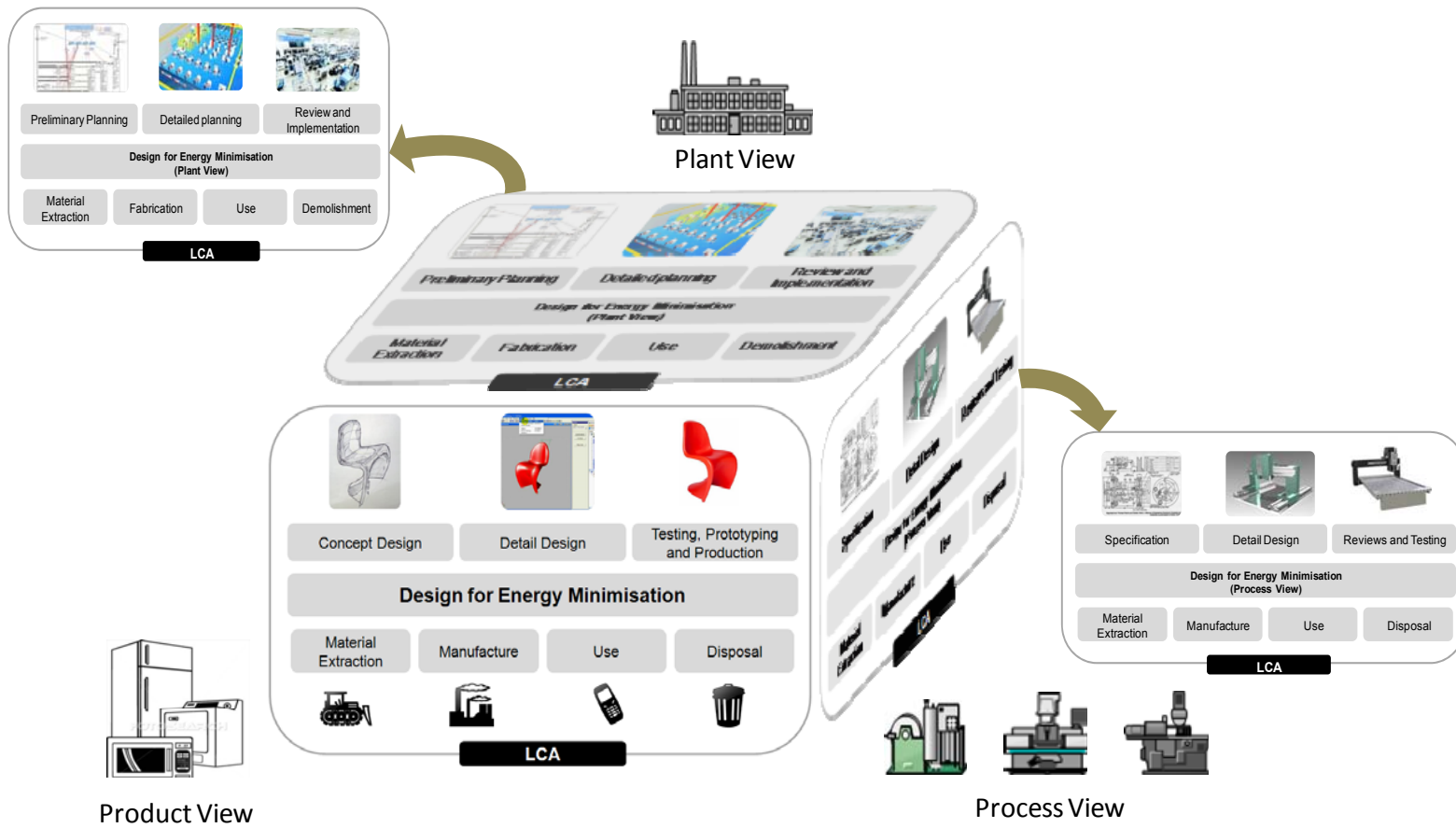

Figure 13.2: Application of the DfEM approach to the Product, Process and Plant view point

References

- Andersen, B. and Fagerhaug, T. (2000) Performance measurement of logistics processes. Proc. ICT in Logistics & Production Management, IFIP WG5.7. June2000, Tronso, Norway.
- Akbari, J., Oyamada, K. and Saito, Y. (2001) LCA of machine tools with regard to their secondary effects on quality of machined parts, *Proceedings EcoDesign 2001: second international symposium on environmentally conscious design and inverse manufacturing*, Tokyo, pp. 347-352.
- ARUP (2010) Legislation in the UK Energy Industry. Available at: http://www.arup.com/Publications/UK_Energy_Legislation_Timeline.aspx [Accessed Aug 2010]
- Ashby, M. F., Miller, A., Rutter, F., Seymour, C. and Wegst, U. G. K. (2008). The CES Eco Selector –Background Reading, Granta Design Ltd., Cambridge.
- Athena Materials Institute (2011) Athena Environmental Impact Estimator. Available at: <http://www.athenasmi.ca/tools/impactEstimator/> [Accessed 24 March 2011]
- Baniszewski, B. (2005) An environmental impact analysis of grinding. B.S. Thesis, Department of Mechanical Engineering, Massachusetts Institute of Technology, Cambridge, MA.
- Banks, J., Carson, J. S., Nelson, B. L. and Nicol, D. M. (2000) Discrete Event System Simulation, 3rd edn, Prentice Hall.
- BERR (2009) Energy consumption in the United Kingdom: industrial data tables, 2008 update, Department for Business, Enterprise and Regulatory Reform. Available at: <http://www.berr.gov.uk/files/file47215.xls> [Accessed 01 June 2009]
- Betts, R. (2009) Met Office Hadley Centre, BBC News, Available at: <http://news.bbc.co.uk/1/hi/sci/tech/8279654.stm>
- Birch, A., Hon, K. K. B. and Short, T. D. (2011) Performance evaluation of DFE tools, *5th International Conference on Responsive Manufacturing - Green Manufacturing (ICRM 2010)*, Ningbo, China, pp. 51-56.
- BizEE (2011), Energy Lens, Energy Management Software. Available at: <http://www.energylens.com/> [Accessed 24 March 2011]
- Boothroyd, G. and Dewhurst, P. (1983) Design for Assembly, Boothroyd Dewhurst, Wakefield, RI.
- Boyd, G., Dutrow, E. and Tunnessen, W. (2008) The evolution of the ENERGY STAR® energy performance indicator for benchmarking industrial plant manufacturing use, *Journal of Cleaner Production*, **16**: 709-715.
- Brown, M. T. and Herendeen, R. A. (1996) Embodied energy analysis and EMERGY analysis: a comparative view, *Ecological Economics*, **19**, (3) 219-235.

- Brown, H.L., Hamel, B.B., Hedman, B.A., Koluch, M., Gajanan, B.C. and Troy, P. (1985) *Energy Analysis 108 Industrial Processes*, Library of Congress, Fairmount Press, Washington, D.C
- Branham, M. (2008) *Semiconductors and sustainability: Energy and materials use in the integrated circuit industry*. M.S. Thesis, Department of Mechanical Engineering, Massachusetts Institute of Technology.
- British Standards Institution (2010) *British Standards PAS 2050. Specification for the assessment of the lifecycle green house gas emissions of goods and services*. BSI.
- British Standards Institution (2009) *British Standards EN 16001. Energy Management Systems - Requirements with guidance for use*. BSI.
- Cakembergh-Mas, A., Paris, J. and Trépanier, M. (2010) Strategic simulation of the energy management in a Kraft mill, *Energy Conversion and Management*, **51**, (5) 988-997.
- Carbon Trust (2008) *The Carbon Trust Standard*, The Carbon Trust. Available at: <http://www.carbontruststandard.com/pages/The-Standard> [Accessed 3 Dec 2008]
- Carbon Trust (2009) *New Carbon Trust Campaign to help save business £1million a day*, The Carbon Trust. Available at: <http://www.carbontrust.co.uk/News/presscentre/one-million-a-day.htm> [Accessed 20 February 2009]
- Carbon Trust (2010a) *Carbon Reduction Commitment Energy Efficiency Scheme (CRC)*, The Carbon Trust. Available at: <http://www.carbontrust.co.uk/policy-legislation/Business-Public-Sector/Pages/carbon-reduction-commitment.aspx> [Accessed 8 July 2010]
- Carbon Trust (2010b) *The Carbon Reduction Label*. Available at: <http://www.carbon-label.com/the-label> [Accessed 24 March 2011]
- Carbon Trust (2011) *Carbon Trust*. Available at: <http://www.carbontrust.co.uk> [Accessed 28 April 2011]
- Chiotellis, S., Weinert, N. and Seliger, G. (2010) Simulation-based, energy-aware production planning, *Proceedings of 43rd CIRP International Conference on Manufacturing Systems*, Vienna, Austria, pp. 165-172.
- Chryssolouris, G. (1991) *Laser Machining Theory and Practice*. Springer-Verlag, New York, NY, USA.
- CleanMetrics (2011) *CarbonScope*, CleanMetrics. Available at: <http://www.cleanmetrics.com/html/carbonscope.htm> [Accessed 24 March 2011]
- Coley, D. (2008) *Energy and Climate Change*, John Wiley and Sons, West Sussex, UK.
- Commission of the European Communities (2007) *A European Strategic Energy Technology Plan, SET-PLAN: Towards a low carbon future,* COM723.
- CO2PE (2009) *Cooperative Effort on Modelling Process Emissions in Manufacturing*, University of Leuven, Belgium. Available at: <http://www.mech.kuleuven.be/co2pe/> [Accessed 24 March 2011]
- Creswell, J.W. (2003) *Research Design: Qualitative, quantitative and mixed method approaches*. Sage Publications.

- Dahmus, J. and Gutowski, T. (2004) An Environmental Analysis of Machining, *Proceedings of the 2004 ASME International Mechanical Engineering Congress and RD&D Exposition*, Anaheim, California, USA.
- Dalquist, S. and Gutowski, T. (2004) Life cycle analysis of conventional Manufacturing techniques: Sandcasting. *Presented at the ASME International Mechanical Engineering Congress and RD&D Exposition*. Nov 13-19, 2004, Anaheim, CA,
- DEFRA (2008) The UK Climate Change Program, Department for Environment, Food and Rural Affairs. Available at: <http://www.defra.gov.uk/environment/climatechange/uk/ukccp/index.htm> [Accessed 18 Nov 2008]
- DECC (2009) Energy Trends, March 2009, Department of Energy and Climate Change. Available at: <http://www.berr.gov.uk/files/file50354.pdf> [Accessed 05 May 2009]
- De Benedetto, L. and Klemes, J. (2009) The Environmental Performance Strategy Map: an integrated LCA approach to support the strategic decision-making process, *Journal of Cleaner Production Early-Stage Energy Technologies for Sustainable Future: Assessment, Development, Application*, **17**, (10) 900-906.
- Devoldere, T., Dewulf, W., Deprez, W., Willems, B., and Duflou, R.J. (2007) Improvement Potentials for Energy Consumption in Discrete Part Production Machines. *Proceedings 14th CIRP Conference on Life Cycle Engineering*, Tokyo, Japan. pp. 311-316.
- Devoldere, T., Dewulf, J., Deprez, W. and Duflou, J. (2008) Energy Related Life Cycle Impact and Cost Reduction Opportunities in Machine Design: The Laser Cutting Case, *Proceedings 15th CIRP International Conference on Life Cycle Engineering*, University New South Wales, Sydney, Australia, pp. 412-419.
- Diaz, N., Helu, M., Jarvis, A., S. Tonissen, Dornfeld, D. and Schlosser, R. (2009) Strategies for Minimum Energy Operation for Precision Machining, *Proceedings of MTTRF 2009 Annual Meeting Shanghai*, PRC.
- Dixit, M. K., Fernández-Solís, J. L., Lavy, S. and Culp, C. H. (2010) Identification of parameters for embodied energy measurement: A literature review, *Energy and Buildings*, **42**, (8) 1238-1247.
- Dewulf, J. (2003) A Pro-Active Approach to Eco-design: Framework and Tools (PhD Thesis). Mechanical Engineering Department, K.I. Leuven, Leuven
- Dewulf, J. and Duflou, J. (2004) The Ecodesign knowledge system - supporting ecodesign education as well as ecodesign knowledge management, *International Design Conference*, Dubrovnik.
- Draganescu, F., Gheorghe, M. and Doicin, C. V. (2003) Models of machine tool efficiency and specific consumed energy, *Journal of Materials Processing Technology*, **141**, (1) 9-15.
- Duflou, J. (2009), Katholieke Universiteit Leuven, CO2PE, Available at: <http://www.mech.kuleuven.be/co2pe!/index.php> [Accessed 08 March 2009].
- Duflou, J., Dewulf, W., Al-Bender, F., Sas, P. and Vermeiren, C. (2002) Parametric Eco-Efficiency Analysis: A DfE Support Tool, *Proc. of 9th CIRP International Seminar on Life Cycle Engineering*, Erlangen, pp. 121-127.

- Duque Ciceri, N., Gutowski, T. G. and Garetti, M. (2010) A tool to estimate materials and manufacturing energy for a product, *2010 IEEE International Symposium on Sustainable Systems and Technology (ISSST)*, pp. 1-6.
- Ecoliban Group (2011) LCA Software - Team 4.0. Available at:
https://www.ecobilan.com/uk_lcatool.php [Accessed 24 February 2011]
- El-Ibiary, Y. (2003) An accurate low-cost method for determining electric motors' efficiency for the purpose of plant energy management, *Industry Applications, IEEE Transactions on*, **39**, (4) 1205-1210.
- EnergyCAP Inc. (2011) EnergyCAP Enterprise Account Tracking. Available at:
<http://www.energycap.com/products/energycap-enterprise-features/account-tracking1> [Accessed 24 March 2011]
- EnerNOC (2011) Energy Management Platform. Available at:
<http://www.enernoc.com/solutions/> [Accessed 24 March 2011]
- EPS Corp (2011) Energy Management Solution - xChange Point. Available at:
<http://www.epsway.com/products-solutions/eps-xchange-point> [Accessed 24 March 2011]
- eSight Energy Group (2011) eSight M&T/EMS Suite. Available at:
<http://www.esightenergy.com/default.aspx> [Accessed 24 March 2011]
- European Commission (2009) Energy, Available at: http://ec.europa.eu/energy/index_en.html [Accessed Jan 2009]
- Evans, L. B. (2003) Saving Energy in Manufacturing with Smart Technology, *World Energy*, **6**, (2), 112-118.
- Fay, R., Treloar, G. and Iyer-Raniga, U. (2000) Life-cycle energy analysis of buildings: a case study, *Building Research and Information*, **28**, 31-41.
- Filippi A.D, and Ippolito R. (1981) NC machine tools as electric energy users. *Annals of CIRP* **3**, (1), 323-326
- Fitch, P. E. and Cooper, J. S. (2004) Life Cycle Energy Analysis as a Method for Material Selection, *Journal of Mechanical Design*, **126**, (5) 798-804.
- Fitzgerald, D. P., Herrmann, J. W., Sandborn, P. A., Schimdt, L. C. and Gogoll, T. H. (2007) Design for Environment (DfE): Strategies, practices, guidelines, methods and tools, In *Environmentally Conscious Mechanical Design* (Ed, Kutz, M.) John Wiley & Sons, New Jersey.
- Fleschutz, T., Azwan Abdul Rahman, A., Harms, R. and Seliger, G. (2010) Assessment of Life Cycle Impacts and Integrated Evaluation Concept for Equipment Investment, *17th CIRP International Conference on Life Cycle Engineering*, eds. Zhang, H. C., Liu, Z. and Liu, G., Hefei, China.
- Fumo, N., Mago, P. J. and Chamra, L. M. (2009) Analysis of cooling, heating, and power systems based on site energy consumption, *Applied Energy*, **86**, (6) 928-932.
- Govil, M. K. and Magrab, E. B. (2000) Incorporating production concerns in conceptual product design, *International Journal of Production Research*, **38**, 3823 - 3843.

- Ghosh, S., Chattopadhyay, A. B. and Paul, S., (2008) Modelling of specific energy requirement during high-efficiency deep grinding, *International Journal of Machine Tools and Manufacture*, **48**, 1242-1253.
- Giudice, F., La Rosa, G. and Risitano, A. (2005) *Product Design for the Environment*, CRC Press, Boca Raton.
- Glasstone, S. and Jordan, W. H. (1980) *Nuclear power and its environmental effects*, American Nuclear Society, La Grange Park, IL.
- Graedel, T. E. and Allenby, B. R. (1996) *Design for Environment*, Prentice Hall, Inc., Upper Saddle River, NJ.
- Granta Design Ltd. (2010), Available at: <http://www.grantadesign.com/> [Accessed 1 July 2010]
- Guinée, J. B., Gorree, M., Heijungs, R., Huppes, G., Kleijn, R., van Oers, L. *et al.* (2002) Handbook on life cycle assessment-operational guide to the ISO standard, Kluwer Academic Publishing, Dordrecht, The Netherlands.
- Gurgel, A., Reilly, J. M.; and Paltsev, S. (2007) Potential Land Use Implications of a Global Biofuels Industry, *Journal of Agricultural & Food Industrial Organization*, **5**, (2), 9.
- Gürzenich, D. and Wagner, H.-J. (2004) Cumulative energy demand and cumulative emissions of photovoltaics production in Europe, *Energy Efficiency, Costs, Optimization, Simulation and Environmental Impact of Energy Systems*, **29**, (12-15) 2297-2303.
- Gutowski, T., Murphy, C., Allen, D., Bauer, D., Bras, B., Piwonka, T., Sheng, P., Sutherland, J., Thurston, D. and Wolff, E. (2005) Environmentally benign manufacturing: Observations from Japan, Europe and the United States. *Journal of Cleaner Production* **13**, (1) 1-17.
- Gutowski, T., J. Dahmus, and Thiriez, A., (2006). Electrical Energy Requirements for a Manufacturing Process. *Proceedings of 13th CIRP International Conference on Life Cycle Engineering*, Leuven, Belgium, 623-627.
- Gutowski, T. G., Branham, M. S., Dahmus, J. B., Jones, A. J., Thiriez, A. and Sekulic, D. P. (2009) Thermodynamic Analysis of Resources Used in Manufacturing Processes, *Environmental Science & Technology*, **43**, (5) 1584-1590.
- Hammer, W. (1980) *Product Safety Management and Engineering*, Prentice-Hall, New Jersey.
- Hansen, J. (2006) The threat to the planet, *New York Review of Books*, **53**, (12) 12–15.
- Hara (2011) Hara Environmental and Energy Management, Available at: http://www.hara.com/solutions_overview.html [Accessed 24 March 2011]
- Harvey, L. D. D. (2009) Reducing energy use in the buildings sector: measures, costs, and examples, *Energy Efficiency*, **2**, (2) 139-163.
- Hauschild, M., Jeswiet, J. and Alting, L. (2005) From Life Cycle Assessment to Sustainable Production: Status and Perspectives. *CIRP Annals - Manufacturing Technology*, **54**, (2) 1-21.

- He, Y., Liu, F. and Cao, H. J. (2005) Process Planning Support System for Green Manufacturing and its application., *Computer Integrated Manufacturing Systems*, **11**, (7) 975:980.
- He, Y., Liu, F., Cao, H. and Zhang, H. (2007) Process Planning Support System for Green Manufacturing and its application, *Frontiers of Mechanical Engineering in China*, **2**, (1) 104-109.
- Heilala, J., Vatanen, S., Tonteri, H., Montonen, J., Lind, S. and Johansson, B. (2008) Simulation based sustainable manufacturing system design, *In Proceedings of 2008 Winter Simulation Conference*, eds. Mason, S. J., Hill, R. R., Rose, M. O., Jefferson, T. and Fowler, J. W., Piscataway, New Jersey, pp. 1922- 1930.
- Hernandez, P., Burke, K. and Lewis, J. O. (2008) Development of energy performance benchmarks and building energy ratings for non-domestic buildings: An example for Irish primary schools, *Energy and Buildings*, **40**, (3) 249-254.
- Herrmann, C., Bergmann, L., Thiede, S. and Zein, A. (2007) Energy Labels for Production Machines - An Approach to Facilitate Energy Efficiency in Production Systems, *Proceedings of 40th CIRP International Seminar on Manufacturing Systems*, Liverpool, UK.
- Herrmann, C., Zein, A., Thiede, S., Bergmann, L. and Bock, R. (2008) Bringing sustainable manufacturing into practice - the machine tool case., *Sustainable Manufacturing VI: Global Conference on Sustainable Product Development and LCE*, Pusan, Korea.
- Herrmann, C. and Thiede, S. (2009) Process chain simulation to foster energy efficiency in manufacturing, *CIRP Journal of Manufacturing Science and Technology, Life Cycle Engineering*, **1**, (4) 221-229.
- Herrmann, C., Bogdanski, G. and Zein, A. (2010) Industrial Smart Metering – Application of Information Technology Systems to Improve Energy Efficiency in Manufacturing, *Proceedings of 43rd CIRP International Conference on Manufacturing Systems*, Vienna, Austria, pp. 134-142.
- Hesselbach, J., Herrmann, C., Detzer, R., Martin, L., Thiede, S. and Lüdemann, B. (2008) Energy Efficiency through optimized coordination of production and technical building services, *15th CIRP International Conference on Life Cycle Engineering*, Sydney, Australia, 2008, pp. 624-628.
- Hirsch, J. (2009) DOE2, Building Energy Use and Cost Analysis Software. Available at: <http://www.doe2.com/> [Accessed 24 March 2011]
- Higgs, T., Cullen, M., Yao, M. and Stewart, S. (2010) Review of LCA methods for ICT products and the impact of high purity and high cost materials, *IEEE International Symposium on Sustainable Systems and Technology (ISSST), 2010*, pp. 1-6.
- HM Government (2006) Climate Change: The UK Programme 2006, Presented to Parliament by the Secretary of State for the Environment, Food and Rural Affairs by Command of Her Majesty, CM6764 SE/2006/43.
- IEA (2006) *Energy Technology Perspectives 2006: Scenarios and Strategies to 2050*, OCDE/International Energy Agency, Paris.
- IEA (2007) World Energy Outlook 2007. OECD/International Energy Agency, Paris

- IEA (2008a) World Energy Outlook 2008, OECD/International Energy Agency, Paris
Available at: <http://www.worldenergyoutlook.org/2008.asp> [Accessed 15 September 2009]
- IEA (2008b) Energy Technology Perspectives 2008: Scenarios and Strategies to 2050, OECD/International Energy Agency, Paris.
- IEA (2009) World Energy Outlook 2009, OECD/International Energy Agency, Paris.
Available at: <http://www.worldenergyoutlook.org/2009.asp> [Accessed 15 September 2009]
- IEA (2010a) Key World Statistics 2010, OECD/International Energy Agency, Paris.
Available at: http://www.iea.org/textbase/nppdf/free/2010/key_stats_2010.pdf
[Accessed 15 September 2009]
- IEA (2010b) World Energy Outlook 2010 Factsheet, OECD/International Energy Agency, Paris. Available at: <http://www.iea.org/weo/docs/weo2010/factsheets.pdf>
[Accessed 15 September 2009]
- ifu (2011) Umberto – Know the Flow, Hamburg Institute for Environmental Informatics GmbH. Available at: <http://www.umberto.de/deen/home/> [Accessed 24 February 2011]
- IPCC (2001) Climate change 2001: synthesis report. Contribution of Working Groups I, II and III to the Third Assessment Report of the Intergovernmental Panel on Climate Change. *Cambridge: Cambridge University Press.*
- IPCC (2007a) Climate change 2007: synthesis report. Contribution of Working Groups to the Fourth Assessment Report of the Intergovernmental Panel on Climate Change. *Cambridge: Cambridge University Press.*
- IPCC (2007b) Climate change 2007: Working Group II Report – Impacts, Adaptation and Vulnerability. Contribution of Working Group II to the Fourth Assessment Report of the Intergovernmental Panel on Climate Change, Cambridge, Cambridge University Press.
- ISO (1990) ISO TR 10314-1: Industrial Automation - Shop Floor Production, International Standards Organisation: Switzerland.
- ISO (1998) ISO 14000 Family of International standards on environmental management, International Standards Organisation: Switzerland.
- ISO (2008) ISO9001 Quality management systems, International Standards Organisation: Switzerland.
- ISO (2010) ISO50001, Energy Management System, International Standards Organisation: Switzerland.
- Itron (2011) T&D Solution By Itron. Available at: <https://www.itron.com/solutions/pages/end-to-end-solutions.aspx> [Accessed 24 March 2011]
- Jönbrink, A.K., Wolf-Wats, C., Erixon, M., Olsson, P. and Wallén, E. (2000) LCA Software Survey, IVL rapport No. B 1390, IVL Svenska Miljöinstitutet AB, Stockholm

- Jones, A. (2007) The industrial ecology of the iron casting industry. M.S. Thesis, Department of Mechanical Engineering, Massachusetts Institute of Technology, Cambridge, MA.
- Joselin Herbert, G. M., Iniyan, S., Sreevalsan, E. and Rajapandian, S. (2007) A review of wind energy technologies, *Renewable and Sustainable Energy Reviews*, **11**, (6) 1117-1145.
- Joseph, B. (2003) Injection Moulding Machine Efficiencies, Southern California Edison Company.
- Jovane, F., Koren, Y. and Boër, C. R. (2003) Present and Future of Flexible Automation: Towards New Paradigms, *CIRP Annals - Manufacturing Technology*, **52**, (2) 543-560.
- Kalla, D., Twomey, J., Overcash, M. (2009) Milling Process, Unit process life cycle inventory.
- Kalpakkjian, S. and Schmid, S. R. (2008) Mechanics of chip formation: Specific Energy, *Manufacturing Processes for Engineering Materials*, Prentice Hall, Singapore. Pg 434
- Kampe, S. L. (2001) ‘‘Incorporating Green Engineering in Materials Selection and Design,’’ Proceedings of the 2001 Green Engineering Conference: Sustainable and Environmentally-Conscious Engineering, Virginia Tech’s College of Engineering and the U.S. Environmental Protection Agency, Roanoke, VA
- Kanungo, A. and Swan, E. (2008) All Electric Injection Molding Machines: How Much Energy Can You Save?, *Proceedings from the Thirtieth Industrial Energy Technology Conference*, New Orleans, LA.
- Kara, S., Manmek, S. and Herrmann, C. (2010) Global manufacturing and the embodied energy of products, *CIRP Annals - Manufacturing Technology*, **59**, (1) 29-32.
- Kara, S. and Manmek, S. (2010) Impact of Manufacturing Supply Chains on the Embodied Energy of Products, *Proceedings of 43rd CIRP International Conference on Manufacturing Systems.*, eds. Sihn, W. and Kuhlmann, P., Vienna, Austria, pp. 187-194.
- Kantardgi, I., Purvis, M., Cherviakov, L. and Khudoshina, M. (2006) Approaches to the modeling of energy utilization in product life cycles, *Clean Technologies and Environmental Policy*, **8**, (2) 77-84.
- Kelton, D. W., Sadowski, R. P. and Swets, N., B (2010) Simulation with Arena, McGraw-Hill, Singapore.
- Keoleian, G. A. and Lewis, G. M. (1997) Application of life-cycle energy analysis to photovoltaic module design, *Progress in Photovoltaics: Research and Applications*, **5**, (4) 287-300.
- Khanna, V., Bakshi, B., Lee James, L. (2008) Carbon nano fibre production-life cycle energy consumption and environmental impacts. *Journal of Industrial Ecology*, **12** (3), 394–410
- Kim, H., Kim, S. and Dale, B. E. (2009) Biofuels, Land Use Change, and Greenhouse Gas Emissions: Some Unexplored Variables, *Environmental Science & Technology*, **43**, (3) 961-967.

- Kissock, K. J. and Eger, C. (2008) Measuring Industrial Energy Savings, *Applied Energy*, **85**, (5) 347-361.
- Knight, P. and Jenkins, J. O. (2009) Adopting and applying eco-design techniques: a practitioners perspective, *Journal of Cleaner Production*, **17**, 549-558.
- KONsys (2011) KONsys, Energy Management Monitoring. Available at: <http://www.konsys-international.com/default.php?cikk=247&EnergyManagementSoftwareDeveloping&lang=en&site=konsys-international.com> [Accessed 24 April 2011]
- Kordonowy, D. N. (2001) A power assessment of machining tools. B.S. Thesis, Department of Mechanical Engineering, Massachusetts Institute of Technology, Cambridge, MA.
- Krishnan, N. and Sheng, P. S. (2000) Environmental versus Conventional Planning for Machined Components, *CIRP Annals - Manufacturing Technology*, **49**, (1) 363-366.
- Krishnan, S. S., Balasubramanian, N., Subrahmanian, E., Arun Kumar, V., Ramakrishna, G., Murali Ramakrishnan, A. and Krishnamurthy, A. (2009) Machine level energy efficiency analysis in discrete manufacturing for a sustainable energy infrastructure, *Second International Conference on Infrastructure Systems and Services: Developing 21st Century Infrastructure Networks, (INFRA)*, 2009, Chennai, pp. 1-6.
- Krause, F.-L., Kimura, F., Kjellberg, T., Lu, S. C.-Y., Wolf, v. d., Alting, L., ElMaraghy, H. A., Eversheim, W., Iwata, K., Suh, N. P., Tipnis, V. A., Week, M. and A.C.H. (1993) Product Modelling, *CIRP Annals - Manufacturing Technology*, **42**, (2) 695-706.
- Kubo, K., Sekiguchi, H., Nakamaru Y. and Kuromatsu, S. (1999) Estimation of energy consumption in steel forging process, *Advanced technology of plasticity - 6th international conference on technology of plasticity*, Nuremberg, September 19-24.
- Kuo, T.-C., Huang, S. H. and Zhang, H.-C. (2001) Design for manufacture and design for 'X': concepts, applications, and perspectives, *Computers & Industrial Engineering*, **41**, 241-260.
- Kuzman, K. and Peklenik, J. (1990) Energy Evaluation of Cold-Forming Processes, *CIRP Annals - Manufacturing Technology*, **39**, (1) 253-256.
- Lewis, N. S. (2007) Toward Cost-Effective Solar Energy Use, *Science*, **315**, (5813) 798-801.
- Lewis, H., Gertsakis, J., Grant, T., Morelli, N. and Sweatman, A. (2001) *Design + Environment*, Greenleaf, Sheffield.
- Lienhard, John H., IV and Lienhard, John H., V (2008) *A Heat Transfer Textbook* (3rd ed.). Cambridge, Massachusetts: Phlogiston Press
- Machado, C.G. and Cavenaghi (2009) Use of life cycle assessment in sustainable manufacturing: review of literature, analysis and trends. POMS 20th Annual Conference, 1-4 May, Orlando, Florida.

- Mattis, J., Sheng, P., DiScipio, W., Leong, K. (1996) A Framework for Analyzing Energy Efficient Injection-Molding Die Design; Engineering Systems Research Centre Technical Report; University of California: Berkeley.
- Mayoux, L. (2005) Quantitative, Qualitative or Participatory? Which Method, for What and When?, In *Doing Development Research* (Eds, Potter, R. and Desai, V.) Sage, Thousand Oaks, London, New Delhi.
- McAloone, T. C. (2000) *Industrial Application of Environmentally Conscious Design*, Professional Engineering Publishing, London.
- McLaren, J., Wright, L., Parkinson, S. and Jackson, T. (1999) A Dynamic Life-Cycle Energy Model of Mobile Phone Take-back and Recycling, *Journal of Industrial Ecology*, **3**, (1) 77-91
- Mills, E., Shamshoian, G., Blazek, M., Naughton, P., Seese, R. S., Tschudi, W. and Sartor, D. (2008) The business case for energy management in high-tech industries, *Energy Efficiency*, **1**, (1) 5-20.
- Moan, J. L and Smith, Z.A (2007) *World Energy Use*, ABC-Clio, Santa Barbra, California, USA.
- Moenne-locco, G., Tremblay, F., Saint-ange, S., Domingo, L. and Bonvoisin, J. (2010) Method and tools to meet energy efficiency targets at product design stage, *5th Going Green – Care Innovation 2010*, Vienna, Austria.
- Mori, Y., Huppel, G., de Haes, H. and Otoma, S. (2000) In *The International Journal of Life Cycle Assessment*, Vol. 5 Springer Berlin / Heidelberg, pp. 327-334.
- Morrow, W. R.; Qi, H.; Kim, I.; Mazumder, J.; Skerlos, S. J. (2004) Laser based and conventional tool and die manufacturing: Comparison of environmental aspects. *Proceedings of Global Conference on Sustainable Product Development and Life Cycle Engineering*; uni-edition GmbH: Berlin, Germany.
- Muller, D. C. A., Marechal, F. M. A., Wolewinski, T. and Roux, P. J. (2007) An energy management method for the food industry. *Applied Thermal Engineering*, doi:10.1016/j.applthermaleng.2007.06.005.
- Müller, E. and Löffler, T. (2010) Energy Efficiency at Manufacturing Plants – A Planning Approach, *Proceedings of 43rd CIRP International Conference on Manufacturing Systems*, Vienna, Austria, pp. 5-12.
- Munoz, A. A. and Sheng, P. (1995) An analytical approach for determining the environmental impact of machining processes, *Journal of Materials Processing Technology*, **53**, (3-4) 736-758.
- Murphy, C. F.; Kenig, G. A.; Allen, D.; Laurent, J.-P.; Dyer, D. E. (2003) Development of parametric material, energy, and emission inventories for wafer fabrication in the semiconductor industry. *Environ. Sci. Technol.* **37**, (23) 5373–5382.
- NIST (2011) BEES, Building for Environmental and Economic Sustainability Software, National Institute of Standards and Technology. Available at: <http://www.nist.gov/el/economics/BEESSoftware.cfm> [Accessed 24 April 2011]
- NREL (2011) Energy Analysis and Tools, National Renewable Energy Laboratory. Available at: http://www.nrel.gov/buildings/energy_analysis.html [Accessed 24 April 2011]

- Optima (2011) Optima Energy Management, Available at: <http://www.optimaenergy.net/?cat=products&view=MandT.html> [Accessed 24 April 2011]
- O'Shea, M. (2002) Design for Environment in conceptual product design - a decision model to reflect environmental issues of all life-cycle phases, *The Journal of Sustainable Product Design*, **2**, (1) 11-28.
- Otto, K. N. and Wood, K. L. (2001) *Product Design - Techniques in Reverse Engineering and New Product Development*, Prentice Hall, New Jersey.
- Optima Energy Management, Available at: <http://www.optimaenergy.net/> [Accessed 20 April 2010]
- Overcash, M., Twomey, J. and Kalla, D. (2009) Unit Process Life Cycle Inventory for Product Manufacturing Operations, *ASME International Manufacturing Science and Engineering Conference*, West Lafayette, IN, USA.
- Pandya, K. V., Karlsson, A., Sega, S. and Carrie, A. (1997) Towards the manufacturing enterprises of the future. *Int. J. Ops Prod. Mgmt.*, **17**: 502-521
- Park, C.-W., Kwon, K.-S., Kim, W.-B., Min, B.-K., Park, S.-J., Sung, I.-H., Yoon, Y., Lee, K.-S., Lee, J.-H. and Seok, J. (2009) In *International Journal of Precision Engineering and Manufacturing*, Vol. 10 Korean Society for Precision Engineering, in co-publication with Springer Verlag GmbH, 151-173.
- Parasiliti, F. and Bertoldi, P. (Eds.) (2003) *Energy efficiency in motor driven systems*, Springer-Verlag, London
- Patel, M. (2003) Cumulative energy demand (CED) and cumulative CO2 emissions for products of the organic chemical industry, *Energy*, **28**, (7) 721-740.
- PE International GmbH (2007). GaBi 4: Software and data base for Life Cycle Engineering.
- Pearce, J. M., Johnson, S. J. and Grant, G. B. (2007) 3D-mapping optimization of embodied energy of transportation, *Resources, Conservation and Recycling*, **51**, (2) 435-453.
- Pei, E. (2009) *Building a Common Language of Design Representations for Industrial Designers & Engineering Designers* (PhD Thesis). Department of Design and Technology, Loughborough University, UK
- PlesTech (2010) Ecofly Home Page. Available at <http://www.ecoflyonline.com/> [Accessed 24 March 2011]
- POST (2006) Carbon Footprint of Electricity Generation, Postnote, Parliamentary Office of Science and Technology. Available at: <http://www.parliament.uk/documents/upload/postpn268.pdf> [Accessed 05 May 2009]
- Pré Consultants (2011). SimaPro7: LCA Software.
- Ptasinski, K. J., Koymans, M. N. and Verspagen, H. H. G. (2006) Performance of the Dutch Energy Sector based on energy, exergy and Extended Exergy Accounting, *Energy*, **31**, 3135-3144.
- Pusavec, F., Krajnik, P. and Kopac, J. (2010) Transitioning to sustainable production - Part I: application on machining technologies, *Journal of Cleaner Production*, **18**, (2) 174-184.

- Rajemi, M. F., Mativenga, P. T. and Aramcharoen, A. (2010) Sustainable machining: selection of optimum turning conditions based on minimum energy considerations, *Journal of Cleaner Production*, **18**, (10-11) 1059-1065.
- Rao, P. N. (2000) Manufacturing technology: metal cutting and machine tools, Tata McGraw-Hill Publishing.
- Rebitzer, G. (2002) Integrating life cycle costing and life cycle assessment for managing costs and environmental impacts in supply chains. In: Seuring, S. and Goldbach, M., Editors, 2002. *Cost management in supply chains*, Physica-Verlag, Heidelberg, 128–146.
- Rebitzer, G., Ekvall, T., Frischknecht, R., Hunkeler, D., Norris, G., Rydberg, T., Schmidt, W.-P., Suh, S., Weidema, B. P. and Pennington, D. W. (2004) Life cycle assessment: Part 1: Framework, goal and scope definition, inventory analysis, and applications, *Environment International*, **30**, (5) 701-720.
- Rockwell Automation (2011) Arena Simulation Software. Available at: <http://www.arenasimulation.com/> [Accessed March 2011]
- Rose, T. J. 2003. “Sustained growth in small enterprises – a process management approach”. School of Industrial and Manufacturing Science, Enterprise Integration, Cranfield University. PhD Thesis
- Ryckaert, W. R., Lootens, C., Geldof, J. and Hanselaer, P. (2010) Criteria for energy efficient lighting in buildings, *Energy and Buildings*, **42**, (3) 341-347.
- Sandvik Coromant (1996) Modern Metal Cutting: A Practical Handbook. Fair Lawn, NJ, USA.
- Sarwar, M., Persson, M., Hellbergh, H. and Haider, J. (2009) Measurement of specific cutting energy for evaluating the efficiency of bandsawing different workpiece materials, *International Journal of Machine Tools and Manufacture*, **49**, (12-13) 958-965.
- Schifo, J.F and Radia, J. T. (2004) Theoretical/ Best Practice Energy Use in Metalcasting Operations, Advance Technology Institute, US Department of Energy
- Seliger, G., Kernbaum, S. and Zettl, M. (2006) Remanufacturing Approaches contributing to sustainable engineering, *Gestao & Producao*, **13**, (3) 367-384.
- Stern, N. (2007) The Economics of Climate Change: The Stern Review, Cambridge University Press.
- Suh, S., Lenzen, M., Treloar, G. J., Hondo, H., Horvath, A., Huppes, G., Jolliet, O., Klann, U., Krewitt, W., Moriguchi, Y., Munksgaard, J. and Norris, G. (2003) System Boundary Selection in Life-Cycle Inventories Using Hybrid Approaches, *Environmental Science & Technology*, **38**, (3) 657-664.
- Sullivan, J. L. and Hu, J. (1995) Life Cycle Energy Analysis for Automobiles, Society of Automotive Engineers.
- Swiss Centre for Life Cycle Inventories (2010) Ecoinvent Database. Available at: <http://www.ecoinvent.ch/> [Accessed 8 June 2010]
- Synthesis Studios (2009) WattzOn Alpha. Available at: <http://www.wattzon.com/> [Accessed 24 March 2011]

- Szargut, D., Morris, R. and Steward, F. (1988) *Exergy Analysis of Thermal, Chemical and Metallurgical Processes*, Hemisphere, New York.
- Tan, X., Liu, F., Dacheng, L., Li, Z., Wang, H. and Zhang, Y. (2006) Improved Methods for Process Routing in Enterprise Production Processes in Terms of Sustainable Development II, *Tsinghua Science & Technology*, **11**, (6) 693-700.
- Taguchi, G. (1986) Introduction to quality engineering: designing quality into products and processes, The Organisation, Tokyo.
- The European Commission (2005) Directive 2005/32/EC of the European Parliament and of the Council of 6 July 2005 establishing a framework for the setting of eco-design requirements for energy-using products and amending Council Directive 92/42/EEC and Directives 96/57/EC and 2000/55/EC of the European Parliament and of the Council 2005. *Official Journal of the European Union*, **L 191**, 29.
- The European Commission (2006) Directive 2006/32/EC of the European Parliament and of the Council of 5 April 2006 on energy end-use efficiency and energy services and repealing Council Directive 93/76/EEC 2006. *Official Journal of the European Union* **L 114**, 64-65.
- The European Commission (2010a) EU Directive 2010/30/EU of the European Parliament and of the Council of 19 May 2010 on the indication by labelling and standard product information of the consumption of energy and other resources by energy-related products *Official Journal of the European Union*, **L153** (18.6).
- The European Commission (2010b) Directive 2010/31/EU of the European Parliament and of the Council of 19 May 2010 on the energy performance of buildings. *Official Journal of the European Union*, **L153**, 13-34
- Thiriez, A. and Gutowski, T. (2006). An environmental analysis of injection molding. *Presented at the IEEE International Symposium on Electronics and the Environment*, San Francisco, CA, May 8- 11.
- Toenissen, S. (2009) Power Consumption of Precision Machine Tools Under Varied Cutting Conditions, LMAS Report. University of California, Berkeley.
- The Royal Society (2010) Climate Change: a summary of the science, London, UK.
- Udo de Haes, H. A. and Heijungs, R. Life-cycle assessment for energy analysis and management, *Applied Energy Industrial Energy Analysis and Management: A European Perspective*, **84**, (7-8) 817-827.
- UPLCI (2011) Manufacturing Unit Process Life Cycle Inventory Heuristics, Available at: <http://cratel.wichita.edu/uplci/>
- US CEEM (2010) Superior Energy Performance, Available at: <http://www.superiorenergyperformance.net/aboutus.html> [Accessed 03 December 2010]
- U.S DOE (2011a) Industrial Technologies Program- Software Tools. Available at: <http://www1.eere.energy.gov/industry/bestpractices/software.html> [Accessed 15 April 2011]
- U.S DOE (2011b) Buildings Technologies Program- EnergyPlus Energy Simulation Software. Available at: <http://apps1.eere.energy.gov/buildings/energyplus/> [Accessed 15 April 2011]

- US EIA (2009) International Energy Outlook 2009. *Washington, DC*: United States Energy Information Administration. Available at:
[http://www.eia.doe.gov/oiaf/ieo/pdf/0484\(2009\).pdf](http://www.eia.doe.gov/oiaf/ieo/pdf/0484(2009).pdf) [Accessed 07 September 2009]
- Vijayaraghavan, A. and Dornfeld, D. (2010) Automated energy monitoring of machine tools, *CIRP Annals - Manufacturing Technology*, **59**, (1) 21-24.
- Weston, R. H., Guerrero, A. and Chatha, K. A. (2007) Process classes deployed in manufacturing enterprises, *Int. J. Comput. Integr. Manuf.*, **20**, (6) 505-523
- Williams, E. D.; Ayres, R. U.; Heller, M. (2002) The 1.7 kilogram microchip: Energy and material use in the production of semiconductor devices. *Environ. Sci. Technol.*, **36**, 5504– 5510.
- Williams, E. (2004) Energy Intensity of Computer Manufacturing: Hybrid Assessment Combining Process and Economic Input-Output Methods, *Environmental Science & Technology*, **38**, (22) 6166-6174.
- Worrell, E., Bernstein, L., Roy, J., Price, L. and Harnisch, J. (2009) Industrial energy efficiency and climate change mitigation, *Energy Efficiency*, **2**, (2) 109-123.
- Yeo, S. H. and New, A. K. (1999) A Method for Green Process Planning in Electric Discharge Machining, *The International Journal of Advanced Manufacturing Technology*, **15**, (4) 287-291.
- Zhang, T. W.; Boyd, S.; Vijayaraghavan, A.; Dornfeld, D. (2006) Energy use in nanoscale manufacturing. Presented at the IEEE International Symposium on Electronics and the Environment, San Francisco, CA, May 8-11.

Comment [Y15]: Added Weston ref

Appendices

Appendix 1 Other methods of Attributing Indirect Energy

Appendix 2 Details of the Modelling Modules used within Arena

Appendix 3 Conference Paper

Improving Product Design based on Energy Considerations

Appendix 4 Journal Paper

A Framework for Modelling Energy Consumption within Manufacturing Systems

Appendix 5 Conference Paper

A Framework for Modelling Energy Consumption within Manufacturing Systems

Appendix 6 Journal Paper

Minimising Embodied Product Energy to support energy efficient manufacturing

Appendix 1

Other Methods of Attributing Indirect Energy

Introduction

This appendix shows the other methods that can be used to attribute Indirect Energy to a product. It also compares the two methods listed here against the method that has been adopted in this research (the use of zones) to illustrate the difference.

A1.1 Averaging IE over the throughput

A1.2 Using area/volume to attribute IE

A1.3 Using zones to attribute IE

A1.4 Comparison of methods

A1.1 Averaging IE over the throughput

The basic method of establishing IE is to average IE of the facility over the number of products or parts that have been manufactured in the facility. The indirect energy of Product A in facility m can be represented by equation A1.1 as shown below.

$$IE_A = IE_{facility(m)} / TP_{area(m)A} \quad \text{[Equation A1.1]}$$

Where,

IE_A is the indirect energy attributed to Product A

$IE_{facility(m)}$ is the indirect energy consumed by the area per hour

$TP_{area(m)A}$ is the throughput of Product A per hour in zone m

If there are 3 processes within a facility and the indirect energy for the facility is 1200 kJ/hr on average and the throughput of the production system is 6 per hour, then the IE for Product A is 200 kJ as illustrated in Figure A1.1.

$$\begin{aligned} IE_A &= IE_{facility(m)} / TP_{area(m)A} \\ &= 1200/6 \\ &= 200 \text{ kJ} \end{aligned}$$

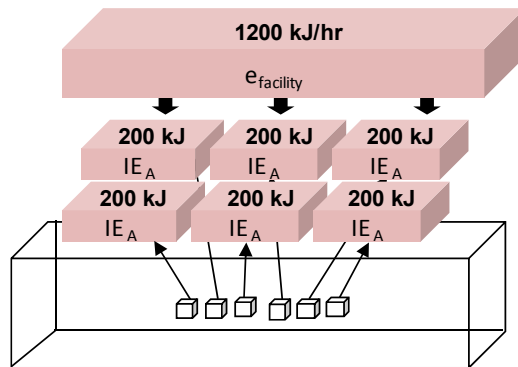

Figure A1.1: The IE for each process is based on average occupied area or volume.

A1.2 Using area/volume to attribute IE

The second method is the attribution of the energy consumed by the environment to the area or volume that is occupied by the process. This method assumes that the energy intensity per area is constant across the manufacturing facility and thus the greater the area occupied by a process, the greater the use of the facility based energy. In some factories, floor space maybe optimised by having production lines across multiple stories, in such cases, volume instead of area can be used as the factor for calculation. The IE of the process is determined based on the percentage of the total area/volume of the factory as depicted by equation A1.2.

$$IE_A = \sum_{i=1}^n \{ IE_{facility} \times \%_{process(i)} / TP_{process(i)A} \} \quad \text{[Equation A1.2]}$$

Where,

IE_A is the indirect energy attributed to Product A

$IE_{facility}$ is the indirect energy consumed by the facility per hour

$TP_{process(i)A}$ is the throughput of Product A per hour for process i

$\%_{process(i)}$ is the percentage of the total facility volume that process i occupies

Assuming there are 3 processes and the IE is for the facility is 1200 kJ/hr on average and the machining process occupies 45% of the volume, the other two processes, polishing and cleaning they occupy 30% and 25% of the volume respectively as illustrated in Figure A1.2.

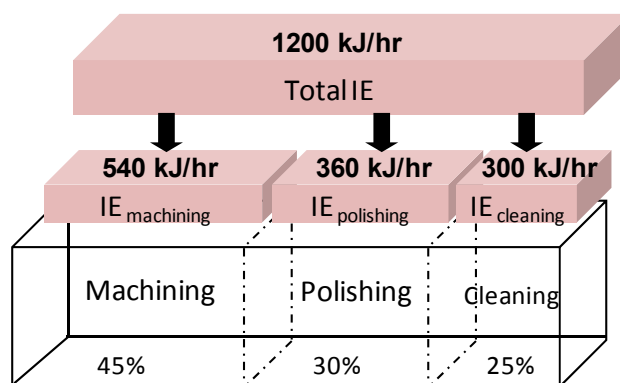

Figure A1.2: The IE is based on the proportion of occupied area/volume

If the throughput of the machining process is 6 then the IE attributed to the machining process for Product *A* can be calculated based on Equation A1.3 and illustrated in Figure A1.3.

$$IE_{A \text{ for Machining}} = IE_{\text{facility}} \times \%_{\text{process(machining)}} / TP_{\text{process(machining)}A}$$

[Equation A1.3]

$$IE_{A \text{ for Machining}} = 1200 \times 0.45 / 6$$

$$IE_{A \text{ for Machining}} = 90 \text{ kJ}$$

Where,

$IE_{A \text{ for machining}}$ is the indirect energy attributed to Product *A* during the machining process

IE_{facility} is the indirect energy consumed by the facility per hour

$TP_{\text{process(machining)}A}$ is the throughput of Product *A* per hour for the machining process

$\%_{\text{process(machining)}}$ is the percentage of the total facility volume that the machining process occupies

By the same method, the IE of each part for the polishing process which has a throughput of 6 is 60 kJ as shown in Equation A1.4:

$$IE_{A \text{ for Polishing}} = 1200 \times 0.30 / 6 \quad \text{[Equation A1.4]}$$

$$IE_{A \text{ for Polishing}} = 60 \text{ kJ}$$

The IE for of each part for the cleaning process which has a throughput of 1 is 50 kJ as shown in Equation A1.5:

$$IE_{A \text{ for Polishing}} = 1200 \times 0.25 / 6 \quad \text{[Equation A1.5]}$$

$$IE_{A \text{ for Cleaning}} = 50 \text{ kJ}$$

As the product moves through the three processes – machining, polishing and cleaning consecutively, then the total IE for the product is the sum of the IE for each process which is 200 kJ as shown previously in Equation A1.6.

$$IE_{A} = IE_{\text{machining}} + IE_{\text{polishing}} + IE_{\text{cleaning}} \quad \text{[Equation A1.6]}$$

$$IE_{A} = 90 + 60 + 50$$

$$= 200 \text{ kJ}$$

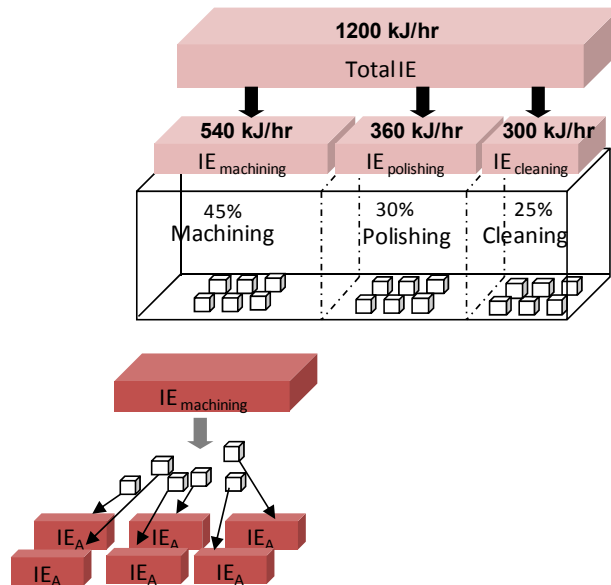

Figure A1.3: The IE is attributed to a product based on the proportion of occupied area/volume and process throughput

A1.3 Using zones to attribute IE

Whilst the second method of using floor area and volume has greater accuracy for the IE values for each process than the first method, it does not take into consideration the differences in energy intensities of the environment required. For some processes such as packaging and inspection the environmental conditions are very different. The packaging line may only require lighting but the inspection line may require a cleanroom environment which includes lighting, ventilation as well as air filtration systems. The energy intensity of the cleanroom is thus significantly higher than the energy requirements of the packaging line environment even though both processes may occupy similar floor areas. In this case, a third method is needed which groups processes that have similar IE requirements together and classes the environment with similar energy intensities as a zone. As described in Chapter 8, the IE attributed to product A in zone x (i.e. $IE_{zone(x)A}$) can be calculated based on total Indirect Energy consumed within zone x (i.e. $IE_{zone(x)T_y}$) within a specific time frame, T_y (where T_y can

be an hour, a shift, a week) divided by the total throughput of Product A through Zone X ($TP_{zone(xT_y)A}$) for time frame T_y as expressed in Equation A1.7:

$$IE_{zone(x)A} = IE_{zone(xT_y)} / TP_{zone(xT_y)A} \quad \text{[Equation A1.7]}$$

Where,

$IE_{zone(x)A}$ is the indirect energy attributed to Product A for Zone x during time T_y

$IE_{zone(xT_y)}$ is the indirect energy consumed by zone x during time T_y

$TP_{zone(xT_y)A}$ is the throughput of Product A through zone x during time T_y

Thus for Zone 1, where IE_{zone1} is 600 kJ/hour, and the $TP_{zone(m)A}$ is 6/hr, the IE for each product is:

$$\begin{aligned} IE_{zone(1)A} &= 600/6 \\ &= 100 \text{ kJ} \end{aligned}$$

By the same method, the IE for Product A for zone 2 which consists only of the cleaning process is $600/6 = 100$ kJ.

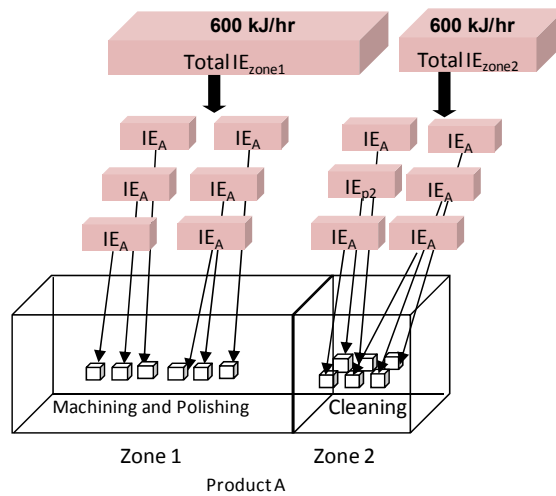

Figure A1.4: The IE is attributed to the product based on the zone it is produced in.

A1.4 Analysis of each method

The three methods of establishing IE for Product A for each process are summarised in Table A1.1. As seen from the table, the allocation of IE to each process for Product A varies greatly depending on the method used. Using the third method as described in Chapter 8 (based on zones) provides greater accountability of the energy used by the manufacturing environment. The cleaning process requires more indirect energy due to more stringent requirements for air quality and lighting compared to the machining and polishing process which only requires basic HVAC and lighting systems. As seen from the calculations, the attribution of IE required by the cleaning process to each product is much higher using the zone based method which reflects the higher indirect energy requirements of the cleaning process. The other two methods, using the average energy values or using floor area, are unable to reflect the energy intensity of the process accurately. The use of averages assumes that the energy intensity of the manufacturing environment required by each process are equal and the use of floor area and volume assumes that the energy requirements are proportional to the area or volume occupied by the production equipment. The zone based method which has been adopted within the framework proposed in this thesis provides a more accurate accountability of energy use base on the level of energy requirement for the production process.

Method of IE Attribution		Total IE for Product A (kJ)	Breakdown on IE for Product A by Process (kJ)		
			Machining	Polishing	Cleaning
7.4.1	Based on average across all processes	200	66.6	66.6	66.6
7.4.2	Based on floor area occupied by the process	200	90	60	50
7.4.3	Based on zones	200	Zone 1		Zone 2
			100		100

Table A1.1: Comparison of IE breakdown by process for various methods of IE attribution

Appendix 2

Details of the Modelling Modules used within Arena

Introduction

This appendix provides details of the modelling modules within Arena that have been used within the simulation model described in Chapter 9. An overview of creating a process chain within the simulation is first given followed by a more detailed description of the individual modules - 'Create', 'Assign', 'Process' and 'Dispose' required to model the process chain.

A2.1 Overview of creating a process chain

A2.2 The 'Create' module

A2.3 The 'Assign' module

A2.4 The 'Process' module

A2.5 The 'Dispose' module

A2.1 Overview of creating a process chain

A simple process route can be created using Arena, products can be modelled as entities, which could represent the parts or products being manufactured and processes can be modelled as events. The use of Arena to model processes also provides the flexibility of having multiple process routes and handling various processing parameters for different products.

The software has its own “language” and it is important to understand the various terminologies that it uses so that the right information can be entered and assigned, which can subsequently be understood by the software.

There are four basic modules typically used to model a process chain within the Arena program:

- 1) Create
- 2) Assign
- 3) Process
- 4) Dispose

An overview of each of the modules are shown in Figure A2.1 which shows a screen print of the Arena window with the main modelling panel where the system being modelled is graphically represented using flowchart representations. The figure shows a production system consisting of 3 manufacturing processes in sequential order with 1 product stream going through the system. The process chain is linked through the use of connector lines, in the Figure A2.1 the process flow starts at the top with the ‘Create’ module and ends at the bottom with the ‘Dispose’ module.

A process chain can easily be created by selecting and placing the modules in the main working window on the right. Through the use of these modules process chains can be created to represent processing lines or production systems within an actual manufacturing facility. Various configurations of process chains can be created by simply altering the connections between modules, thus providing a great deal of flexibility for the user.

Figure A2.1 also shows the project bar where the various other modelling functions can be found. The project bar provides access to the different modules which have been

grouped into – basic processes, advance transfer and advance processes. More complex process chains can be modelled using these additional modules such as the ‘Decide’ module which allows entities to pass through a different process chain depending on its property, for an in-depth description on modelling complex multiple process chains refer to Kelton *et al.* (2009).

The toolbar provides access to the standard file management functions such as ‘save’, ‘new’ and ‘open project’. In addition formatting and animation functions are also found here. The selection of various graphs that provides statistical displays during the simulation runs can also be toggled from here.

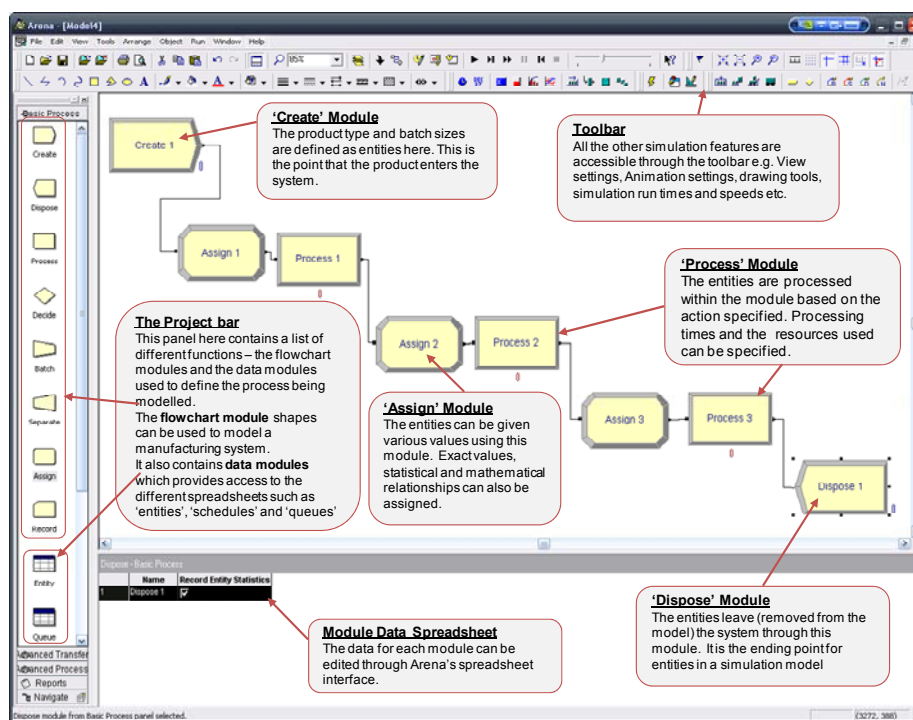

Figure A2.1: Overview of simulation window in Arena showing the different modelling modules used to create a process chain.

A2.2 The 'Create' module

The 'Create' module allows entities to enter the model. Entities are individual items being processed through the system such as a part or a product. The entities are defined by an Entity module which provides data to the modelling system but is not graphically represented within the system flow. They are the dynamic objects in the simulation and represent the objects moving through the system. The entities are created either by the user or automatically by the software, move through the system and then are disposed off. In a production system, it would be the parts to be processed (i.e. the component is created, processed by the milling machine, then leaves). Data is entered within the Entity spreadsheet as seen in Figure A2.2.

Within the window is possible to specify entity types, the number of entities that enter the system per hour the statistical distribution of the arrival etc. It is also possible to create different kinds of entities (different Entity Type) that go through different processing routes. In the complex conceptual model, 3 entities can be specified to each represent different components through the different process routes; this has been demonstrated in the case study in Chapter 10.

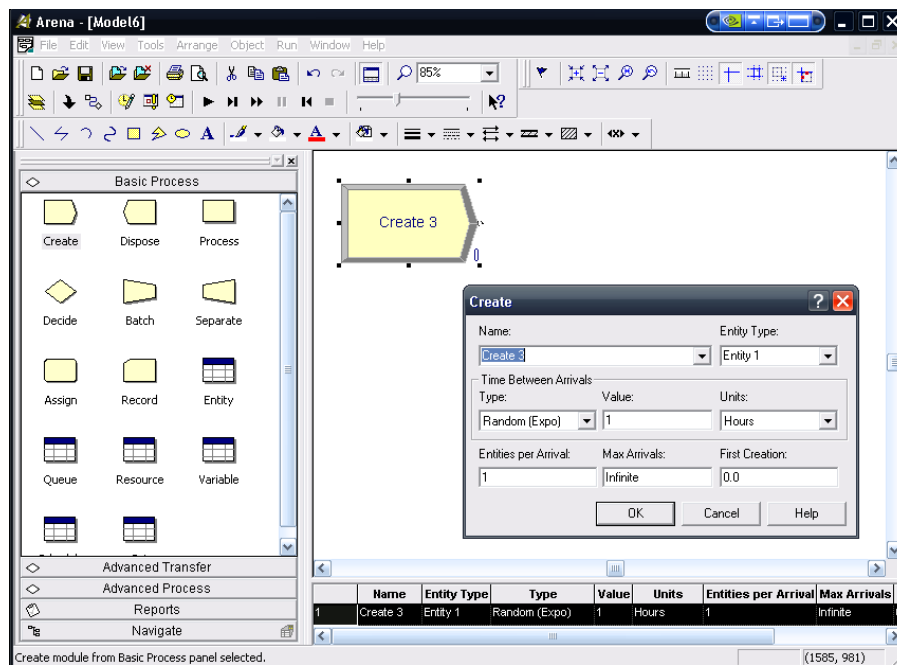

Figure A2.2: Arena window with the 'Create' module selected and the data entry window for the module open

A2.3 The 'Assign' module

The 'Assign' module allows specific parameters to be given to the entity, this includes specific values, or values assigned through statistical distributions or values derived from mathematical relationships. For example if an entity has a mass of 0.5 kg the assign module can be used to tag information onto the entity as it passes through the system as shown in Figure A2.3. This is useful when product parameters need to be specified for calculating the energy values in the Energy Simulation. Besides allocating fixed values, it is also possible to incorporate mathematical equations and statistical distributions.

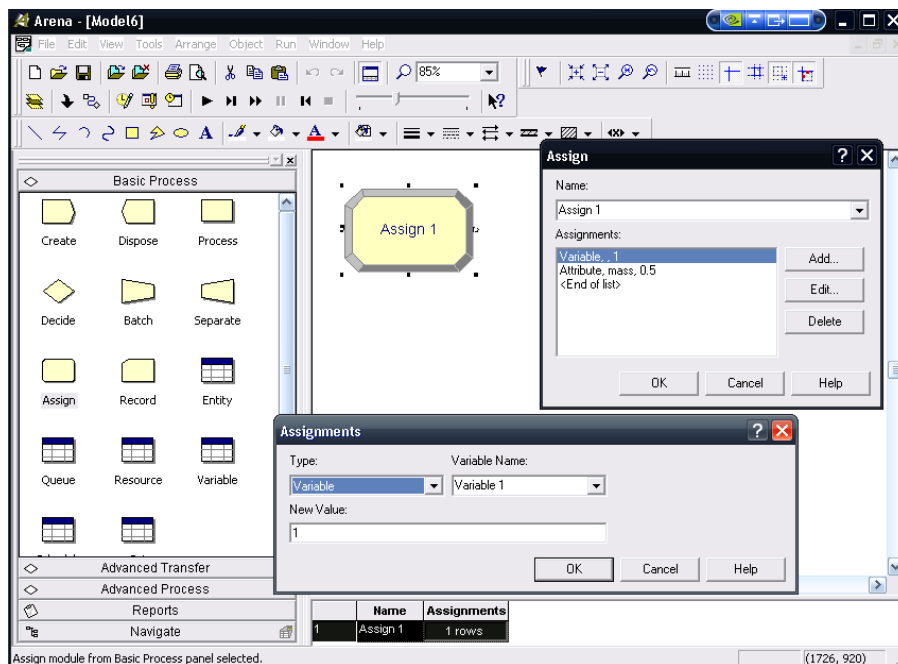
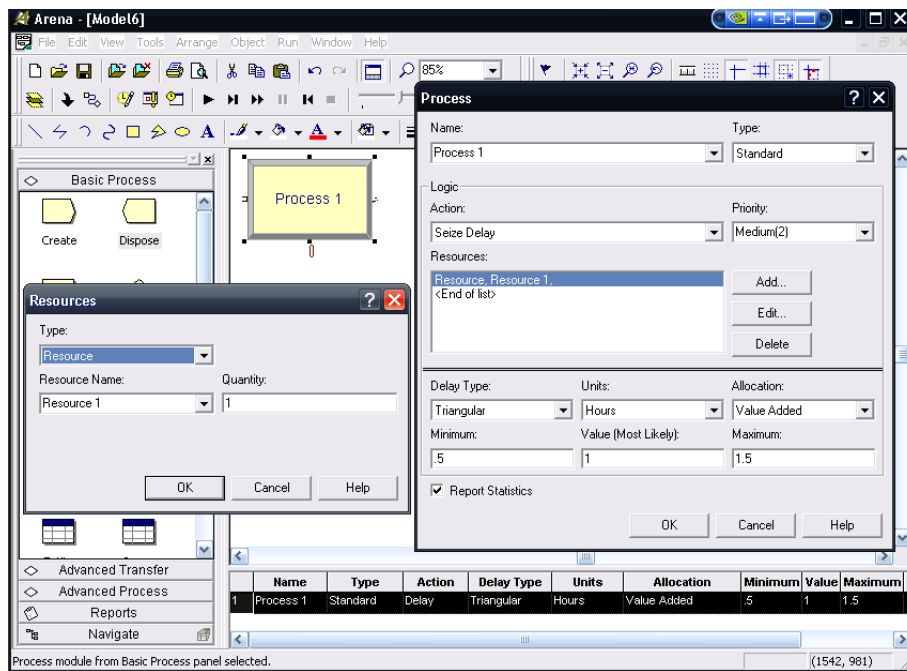

Figure A2.3: The 'Assign' module as well as the data window showing how to tag information to an entity. In this case the entity is given a mass of 0.5 kg whenever it passes through this module.

A2.4 The 'Process' module

The 'Process' module allows a process to be performed on each entity. In a production system, this could be a milling process or a casting process. The process is represented as a duration of time and can have resources allocated to it such as a milling machine and/or a human operator. A screen print of the 'Process' module and the resource window is shown in Figure A2.4.



FigureA2.4: The 'Process' module as well as the data window showing the allocation of resources to the process

A2.5 The 'Dispose' module

The 'Dispose' module represents the departure of each entity from the system, i.e. the part has been manufactured. Figure A2.5 shows a print screen of the modelling window with the three modules – 'Create', 'Process' and 'Dispose' placed together to create a complete system flow in the simulation area.

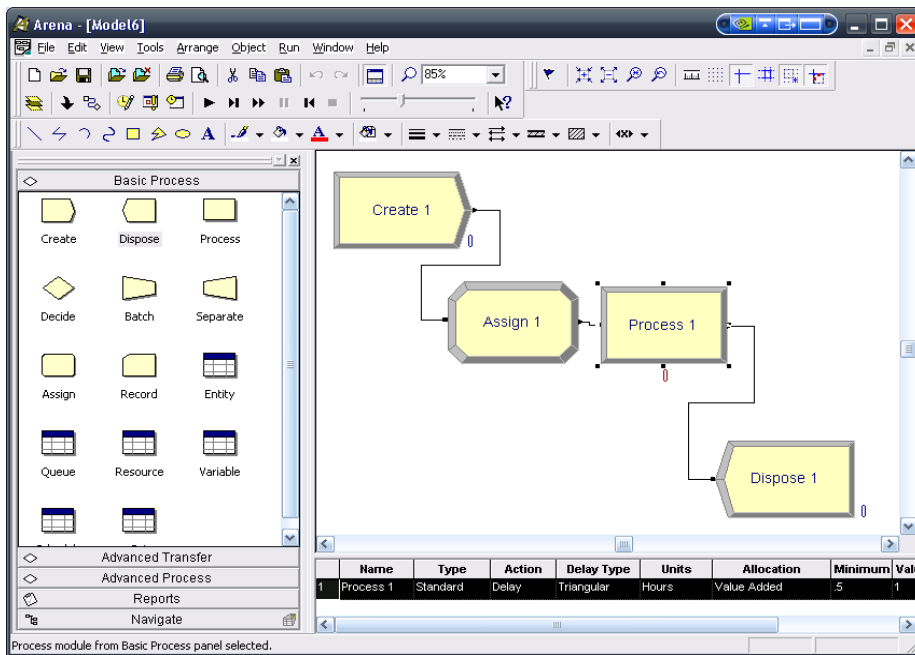

Figure A2.5: Arena window showing the simple system created with the 4 modules.

Appendix 3

Conference Paper

Improving Product Design based on Energy Considerations

Introduction

This paper was presented at the 18th CIRP International Conference on Life Cycle Engineering, Braunschweig, Germany, May 2nd - 4th 2011.

Improving Product Design based on Energy Considerations

Yingying Seow, Shahin Rahimifard

Centre for Sustainable Manufacturing and Reuse/Recycling Technologies, Loughborough University, UK

Abstract

The industrial sector consumes a significant amount of the world's energy supply; the rationalisation of energy consumption would provide the most effective method of reducing greenhouse gas emissions attributed to manufacturing and use of products. Energy consumed across the various stages of a product's lifecycle varies significantly depending on the product design and its application. In non-energy using products such as furniture, food, and clothing, the material preparation and production phases represent a significant proportion of energy consumption over the product lifecycle. This paper proposes a new design methodology targeted at these products to minimise energy consumption during 'production' phase.

Keywords:

Energy efficiency; Design for the Environment; Low Carbon Manufacturing

1 INTRODUCTION

Increasingly, energy consumption of products has become the focus of environmental concerns due to carbon emissions from the combustion of fossil fuels for energy generation. As energy demand continues to grow and fossil fuels remain the main source for power generation in the foreseeable future [1] the most effective method of CO₂ reduction is still through the rationalisation of energy consumption. This has led governing bodies to introduce a number of energy auditing and accreditation standards, such as European directives on the 'Eco-Design of Energy using Products (EU Directive 2005/32/EC)' and 'Energy End-Use Efficiency and Energy Services (EU Directive 2006/32/EC)'.

According to Otto and Wood [2], 80% of the environmental damage of a product is established after 20% of the design activity is completed. Decisions made early in the conceptual design phase can influence the outcome of a design exercise more significantly than any optimisation step later on in the design process [3]. Therefore environmental considerations should be integrated early in the design phase during the product development process, see Figure 1 [4]. The most commonly adopted method is 'Design for Environment' (DfE) which is concerned with the impact of design throughout the lifecycle, from material preparation and manufacture to use and end-of-life management of a product [5].

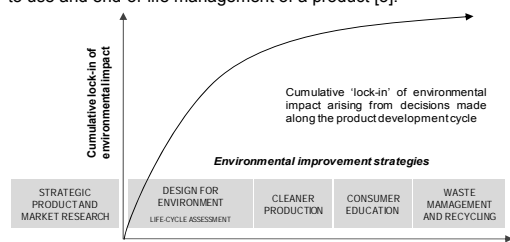

Figure 1: Conceptual representation of environmental 'lock-in' over a product's development cycle [4].

DfE considers a range of environmental issues associated with a product including resource consumption, end-of-life disposal, waste management, recyclability reusability and use of toxic and hazardous materials.

Energy is clearly consumed across the various stages of a product lifecycle; furthermore the level of energy consumed in each lifecycle phase significantly varies depending on the product. For example in the case of electrical products, the greatest contributor to environmental impact is often due to the consumption of electricity during the 'Use' phase, thus the reduction of this energy use during this stage has been the focus of most design tools and guidelines. However in the majority of manufacturing applications, the production phase still represents a significant proportion of energy consumed over a product's lifecycle, in particular for non-energy consuming products. This highlights the need to investigate the opportunities for optimisation of energy consumption during the production through design improvements.

This paper proposes a new design methodology which aims to minimise the energy consumption during the manufacturing phase of a product. This is achieved by providing a detailed breakdown of energy flows attributed to the production of a product and utilise this energy data to improve the design process. The initial section of the paper provides an overview of 'Design for X' approaches, together with an overview of the established design methodologies used in most applications. The latter part of this paper describes the Design for Energy Minimisation (DfEM), during manufacture and outlines its application in the design of a chair.

2 PRODUCT DESIGN AND THE APPLICATION OF DfX TOOLS

2.1 Product Design Process

A common design model as proposed by Pugh [6] consists of four generic stages: 1) Specification, 2) Conceptual Design, 3) Detail Design and 4) Manufacture. As illustrated in Figure 2.

The first stage involves planning of the design task by collecting information about the customer requirements and creating a product design specification. The next step is to generate ideas by searching for essential problems and combining working principles and selecting a suitable concept. The third stage is detail design which develops the concept chosen at the previous stage into a more concrete proposal with specifications of geometry, materials and tolerances of all parts in the product. Production costs and robust performance are the main concern at this stage. Finally the last stage is manufacturing and typically at this stage the main design aim is to minimize the component and assembly cost.

Various design for 'X' (DfX) tools can be applied to each design stage. DfX is a term that is used to represent a variety of considerations that must be made whilst designing a product and stems from the fact that designers cannot be subject experts on every factor that arises during the design process. It can be used in the early stages of concept design as a benchmarking tool as well as helping to simplify new un-built concepts [2]. For example Design for Life Cycle which considers the environmental impact of a product from cradle to grave, may mean a radical design change to a vehicle such as powering a car from renewable energy to minimize the impacts from the use of fossil fuels. Other DfX tools like Design for Manufacture and Assembly might be considered to minimize the number of parts thereby reducing manufacturing and assembly costs and time. Figure 3 shows an example of how the various DfX tools alongside others, can support the different phases in the product development process.

More recently with the increasing concern about climate change and the environmental impact of products, a new generation of DfX tools have been developed to help designers reduce these impacts through their design. These tools aim to integrate environmental considerations in the design of new products to reduce the overall environmental impact of a product [8,9] as most of the environmental impact in a product's lifecycle is 'locked in' into the product at the design stage when materials and production process are selected, and product performance is largely determined.

Type	Use	Problem Solving	Product Synthesis	Product Development
Strategies	Learning strategy	Trail and Error	Integrated Pdt Development	
	General problem solving Strategy	Abstraction Combination	Concurrent engineering	Total Design
Procedures		Chris Jones	VDI2221	IPD
			Tjalve	Pugh
Methods	Brainstorming / Evaluation	Reasoning	Needs/Competitor Analysis	
	Synectics	635	Morphology	Design Catalogues
	Sketching	Variation	Specifications	Business Search Team Milestones
Models	Sketch	Photo	CAD	Experiments
	Writing		Mathematical Model	Design Model Prdts for Experiments
	Drawing		Simulation	Prototype Mock up Functional Model Zero Series Product
DFX			DFA	DFE
			DFM	DFQ
Technical Means			FEM	DFC
			CID	CAD/CAM
			CAD	Workbench

Figure 3: Application of various design tools in problem solving, product synthesis and in product development [7].

As there is no single measure for environmental impact, various tools and techniques have been developed under the DfE strategy some of which are: Design for recyclability [10], Design for disassembly [11], Design for Lifecycle [12], Lifecycle Costing [13], Sustainable design [14] and Design for End-of-life [15].

This research paper is proposing a new framework for improving product design through energy considerations. To demonstrate how a Design for Energy Minimisation approach can be adopted across the various design stages, 3 generic phases of Concept design (CD), Detail design (DD) and Manufacture (M) in line with Pugh's [6] design methods have been used.

2.2 Design for Energy Minimisation Approach

DfEM is a wide ranging consideration that not only includes energy consumed during the Use phase, but also considers the other stages in the lifecycle. This is currently supported by Life Cycle Assessment (LCA) which is used to compile and evaluate the environmental burdens of the product from the material production to part manufacture, product assembly, operation, servicing, maintenance and end-of-life disposition [16]. However there are two main shortcomings with conducting a LCA:

1) The inventory analysis required in a LCA is time consuming due to the complexity and data intensive nature of the process. In various studies conducted [17,18,19] the industry found this process to be too complex and requiring a great deal of effort for existing products. The data intensive nature of a LCA coupled with the lack of accurate data related to the energy consumption across the entire lifecycle of a product often results in significant assumptions and simplifications [19]. This is perhaps even greater for a product that does not yet exist as it is unrealistic for a designer to have access to all the specific information about the materials and processes required for a comprehensive LCA at the early stages of product design i.e. concept design phase.

2) On a more specific level, the energy data available in existing Life cycle inventory (LCI) databases such as the Ecoinvent [21] database is based mainly on industry sectors located in Switzerland and Western Europe and is therefore not always relevant for products that are manufactured in a different location. In addition, much of the process energy data is indicated as kJ per unit weight of material processed which does not provide any indication of how much energy was used by the manufacturing facility, how much

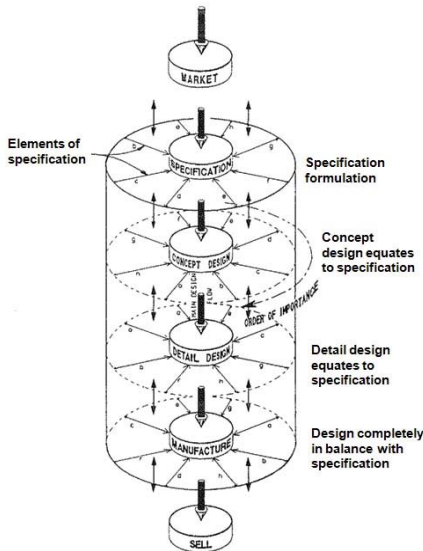

Figure 2: Pugh's product design model showing the 4 central stages of the product design process [6].

was for the actual processing and how much was from the supporting auxiliary processes. The total energy consideration established through the LCI can only provide a generic ballpark energy consumption value which may not be reliable for processes which are executed in a different way in other manufacturing environments. Hence there is a need to consider the energy flow modelling during the 'manufacturing' phase in more detail.

For these reasons, there have been a number of recent developments in the following two areas:

- a. In order to minimize the complexity and time taken to conduct a full LCA, simplified models and additional assumptions have been used to reduce the evaluation effort in traditional LCA.

These condensed LCA are known as streamlined LCA (S-LCA) which encompasses a group of approaches designed to simplify and reduce the time, cost and effort involved in conducting a full LCA while still facilitating accurate and effective decisions. For example, Granta Design [22] has developed a simplified LCA tool called the Eco Audit tool (part of the Cambridge Engineering Selector (CES) suite of software) which uses information about product composition, processing, usage, transportation, and disposal. The tool then combines this with eco property data on the materials and processes used in the design to calculate the energy usage and CO₂ output resulting from each stage in the product lifecycle, see Figure 4. This high level overview is particularly useful during the first stage of product design (i.e. concept design) which can guide the design strategy by the identifying the lifecycle phase which has highest environmental impact.

- b. In order to gain an accurate picture of the energy consumption in manufacturing, energy management systems are now used to track and measure the energy used in a production facility, providing a breakdown of energy consumption by various elements in a production system including both the buildings and production facilities.

An example of energy management software is Optima developed by Optima Energy Management [23]. It can track and monitor real time energy consumption, buys energy at best available prices and allows budgets and targets to be set for cost savings. Whilst AEMS provides correlation with external factors affecting energy use such as weather and building occupancy, much of the data is related to building energy consumption and only provides a high level breakdown of a plant's energy consumption by generic areas.

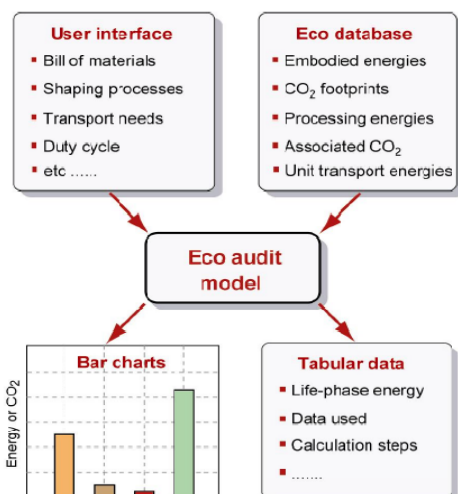

Figure 4: Inputs and outputs for the Eco Audit Tool [21].

In this context, the authors argue that a holistic DfEM approach should first provide support across the design process from concept design to manufacture and should secondly consider the energy consumption throughout the entire product life cycle. S-LCA tools such as CES mostly provides support during the concept design stage by providing high level energy information of each phase of a product lifecycle whilst AEMS provides support at the manufacture stage through the monitoring and tracking of energy consumption within the manufacturing facility. This highlights the need for a tool at the detail design phase that can provide energy data that is sufficiently detailed to correlate production processes and operation parameters to energy consumption. It is therefore proposed that an Energy Simulation Model (ESM) can be used at the detail design phase to bridge the gap between high level simplified LCA tools used at conceptual design and those used to monitor energy consumption as part of the manufacturing stage, as illustrated in Figure 5. This is achieved through a framework to model energy flows within the manufacturing phase of a product lifecycle and to support the detail design activities within the product design process which is described in the next section.

3 ENERGY SIMULATION MODELLING FRAMEWORK

Much of the current work on energy consumption within production or manufacturing can be broadly viewed under two different perspectives of 'plant' and 'process'. The work directed at the 'plant' level has focused on the energy consumed by infrastructure and other high level services that are responsible for maintaining the required production conditions/environment [24, 25]. Examples of such energy consuming activities would be heating and lighting, transportation equipment and ventilation systems [26]. On the other hand, research concentrating on the 'Process' levels have targeted energy consumption of the individual equipment, machinery and workstation within a production system [27, 28].

This research proposes a third perspective which considers the energy consumed by a product as it is being manufactured and attributes the energy used on the plant and process levels to single unit of product made. This also includes energy that is required for pre-production (i.e. material preparation), production (i.e. machining) and post production (i.e. packaging). This 'product' perspective along with the other two 'plant' and 'process' viewpoints on energy modelling are depicted in Figure 6.

Currently most energy analysis of a product is conducted through a LCA methodology which typically uses the weight of the material

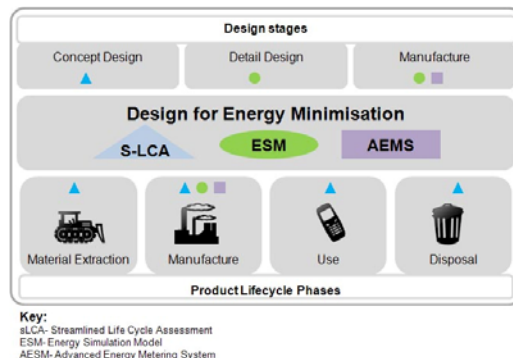

Figure 5: DfEM should support the design process as well as the product's lifecycle.

being processed as the basis for the calculation. This paper proposes a different approach to energy modelling which differs from traditional LCA calculations by taking into account the amount of material being processed as well as the processing time required to convert these materials to finished products. For example in the case of machining processes, it is not only the weight of the material removed but also the complexity of the required operations (e.g. number of holes or slots), hence the total processing time, can greatly influence the energy consumption.

In this framework, the energy consumed within a manufacturing facility is categorised into Direct Energy and Indirect Energy. The Direct Energy (DE) represents the energy utilised by the manufacturing processes used to produce the product. This includes pre-production, production and post-production processes (e.g. casting, machining, spray painting, inspection, etc). The Indirect Energy (IE) is the energy consumed by activities required to maintain the 'environment' in which the production processes are carried out within a manufacturing plant (e.g. lighting, heating, ventilation, etc.). Further details of this framework can be found in Rahimifard and Seow [29]. In this approach, the EPE model is not only able to detail the energy consumption for the various processes, but also highlights the energy hotspots within a manufacturing facility to support energy efficient manufacturing [30]. Energy intensive or energy inefficient processes can be identified for replacement or improvement.

The energy simulation model consists of a simulation engine, an energy database, and a decision support tool, see Figure 7. The simulation engine is based on the framework and has been developed to allow a number of 'what-if' scenarios for the analysis and evaluation of energy consumption during the manufacturing phase of a product life-cycle. The simulation engine which has been developed using Arena™, a discrete event simulation and automation software from Rockwell Automation is capable of modelling various manufacturing process flows for different products and can be expanded to include product or process variations. Additional production variations such as batch sizing, lead times and queue times can also be included. The energy database also provides the simulation engine with the primary energy information such as energy values associated with the manufacturing processes and auxiliary activities.

Initial data can be determined either theoretically or empirically and statistical relationships can eventually be established to train the simulation engine to predict the amount of energy consumed by the processes and activities for different production parameters such as batching, queue times, process routing and process set ups.

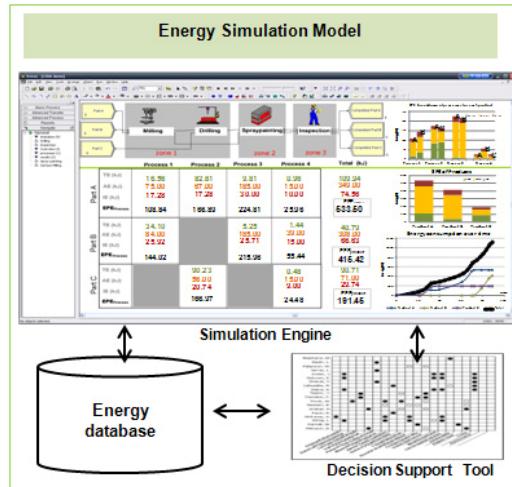

Figure 7: Energy simulation model consists of the decision support tool, the energy model data base and the modelling engine.

As the energy model becomes more robust, the data output from the predictive models can in turn be added into the energy database to build up a comprehensive understanding of the energy requirements of processes and production systems. It should be noted that the data related to energy consumption within logistics and reverse logistics activities can also be included.

The final aspect of the energy simulation model is the decision support tool which correlates various design and processing parameters with energy consumption data derived from the energy database. Using a correlation matrix, the energy intensity and efficiency of various manufacturing parameters can be evaluated against the functional requirements of the product to derive at a design that has minimal energy consumption during manufacturing.

This energy simulation model not only supports operational decisions but also provides energy transparency right back to the design process, enabling designers to select the most energy efficient materials and processes whilst fulfilling the requirements in the product specification. Such an approach will potentially enable businesses to go beyond the incremental improvements achievable via existing energy management systems to consider energy efficiency and utilisation across both the design and manufacturing phases of a product life cycle.

4 APPLYING DFEM TO PRODUCT DESIGN

4.1 Tools to aid DfEM

As mentioned before, the adoption of DfEM methodology involves a series of tools that can be applied at the different stages in the product design process. For example at the conceptual design phase where high level decisions are required for concept selection a simplified LCA package like CES Eco Selector could be adopted to provide an overview of the energy requirements for a new design within a product lifecycle. CES Selector can provide support to determine the appropriate materials based on specific product specification [31] and relate the energy consumption to the selected materials. It can also provide designers with a rough estimate of the energy requirements of processes which can aid decision making when short listing suitable processes.



Figure 6: Different Perspectives of Energy Modelling.

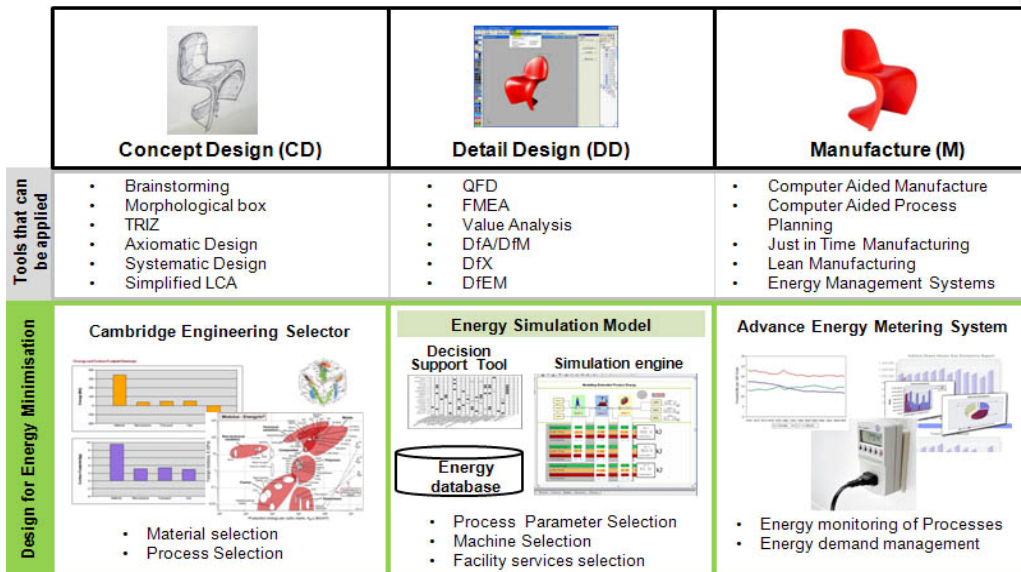

Figure 8: Application of various tools in a product design process to aid energy minimisation

In the second phase- detail design, where product structure, assemblies and components are established, there is a need for more detailed considerations of the relationships between product attributes and production processes required for manufacturing. At this stage the decision support tool can be used to identify trade-offs between energy intensity of processes and functional requirements. After a process has been chosen, the energy simulation model can be used to evaluate the energy consumption during the manufacture, and hence provide appropriate information during the selection of least energy intensive processes or setting process parameters so that they consumed the least energy. In a similar manner during the final phase (i.e. manufacturing stage), production machinery and facilities need to be monitored to improve energy flows and efficiency. Advance energy management systems can be used to measure, record and improve the energy consumption within a production system and track energy demand of the manufacturing site.

4.2 Application of DfEM to a Product

DfEM was applied to the design and manufacture of a plastic chair to evaluate the areas where energy consumption could be minimised. In the case of a simple product like a plastic chair, various energy considerations and goals can be defined for the product at the start of the development phase and while creating a Product Design Specification (PDS). In this case, the CES Eco Selector can be used to assess the energy requirements for extraction, preparation and processing of various plastics to further narrow down the list of materials that meet the functional requirements of this product.

This evaluation may show that of the Acrylonitrile-Butadiene-Styrene (ABS) and reinforced Polypropylene (PP) can both fulfil the product specification, but PP is the least energy intensive to extract and prepare. After selection of the material, the energy simulation model can then be used to evaluate the various production processes that can be used to manufacture the chair using the PP, and provide an indication of the least energy intensive processes. In this case due to specific product geometry, the feasible processes that can be adopted are high impact injection moulding and gas assisted injection moulding. The evaluation of these two processes indicates that the gas assisted

injection moulding will potentially consume more energy due to the high energy requirements for compressed air. The energy model is therefore able to determine energy hotspots at the same time provide a breakdown of the energy consumed by the direct processes, auxiliary processes as well as the indirect processes from the facility.

This information could aid the decision making when deciding on the best method of manufacturing of the product and provide designers with a greater insight into energy consumption. Finally during the actual production of the chair, AEMS can be used to monitor the real time energy consumption by injection moulding, process cooling, drying ovens, heating and ventilation systems as well as lighting to improve the efficiency of the production facility.

Although these tools can be used independently within each phase of the design process, clearly greater benefits could be achieved through integration of these tools, as the data/knowledge generated by each can support the decision made in other phases. For example, the data collected from the AEMS can help to improve and expand the database used by the ESM, providing more accurate energy consumption values for the actual production facility rather than a generic plant. Likewise, ESM can help CES by providing more customised data for the processes carried out at the facility so that an accurate streamlined LCA can be carried out for subsequent products designed and manufactured at the plant.

5 CONCLUSIONS

Design is an integral part of any product development process and much of the decisions taken at this stage accounts for majority of the financial and environmental cost of a product. Therefore to reduce the energy consumption of a product during the manufacturing stage, energy considerations need to be included at the design stage. By identifying where the energy is used during production and how productively it is used, the designer gains an insight into the energy effectiveness of the process in relation to a product. This knowledge can empower the designer to intelligently explore the suitability of a product feature, a material and consequently the chosen manufacturing process with energy minimisation in mind.

The DfEM methodology presented in this paper together with the simulation tool would enable designers to do 'what if' scenarios to identify the most practical and economically feasible design improvements that could reduce the need for energy consumption during manufacture.

Clearly the scope of this approach has to be extended to consider the energy considerations related to wider issues within a product life cycle such as the energy requirements during the use phase, logistics and reverse logistics and end-of-life. As such this approach should be used in conjunction with other LCM tools to evaluate the overall life cycle impact of the product to ensure that the absolute environmental impact is reduced and not increased. The matter of minimising energy consumption of a production system must be addressed as part of a multi objective optimization problem.

6 REFERENCES

- [1] World Resource Institute (2005) Greenhouse Gas Emissions: 2005, Available at: <http://www.wri.org/chart/world-greenhouse-gas-emissions-2005>, [Accessed 10 August 2009]
- [2] Otto, K. N. and Wood, K. L. (2001) *Product Design - Techniques in Reverse Engineering and New Product Development*, Prentice Hall, New Jersey.
- [3] Dufflou, J. R. and Dewulf, J. (2004) Eco-Impact anticipation by Parametric Screening of Machine System Components, In *Product Engineering* (Eds, Talaba, D. and Roche, T.) Springer, Netherlands, pp. 17-30.
- [4] Lewis, H., Gertsakis, J., Grant, T., Morelli, N. and Sweatman, A. (2001) *Design + Environment*, Greenleaf, Sheffield.
- [5] Hauschild, M. Z., Jeswiet, J. and Alting, L. (2004) Design for Environment -- Do We Get the Focus Right?, *CIRP Annals - Manufacturing Technology*, **53**, (1) 1-4.
- [6] Pugh, S. (1991) *Total Design-Integrated Methods for Successful Product Engineering*, Addison-Wesley Publishers, Essex, UK.
- [7] Hein, L. (1994) Design Methodology in Practice, *Journal of Engineering Design*, **5**, (2).
- [8] Fiksel, J. R. (Ed.) (1996) *Design for environment: creating eco-efficient products and processes*, McGraw-Hill, New York.
- [9] Holt, R. and Barnes, C. (2009) Towards an integrated approach to "Design for X": an agenda for decision-based DFX research, *Research in Engineering Design*.
- [10] Henstock, M. E. (1988) *Design for Recyclability*, Institute of Metals on behalf of the Material forum.
- [11] Subramani, A. K. and Dewhurst, P. (1991) Automatic generation of product disassembly sequence, *CIRP Annals - Manufacturing Technology*, **40**, (1) 115-118.
- [12] Alting, L. (1991) Life Cycle Design, *Concurrent Engineering*, **1**, (6) 19-27.
- [13] Woodward, D. G. (1997) Life Cycle costing-theory, information acquisition and application, *Int J Project Manag*, **15**, 335-344.
- [14] Elkington, J. (1997) *Cannibals with Forks: the triple bottom line of 21st century business*, New Society, Gabriola Island.
- [15] Rose, C., Stevels, A. and Ishii, K. (2000) A new approach to end-of-life design advisor (ELDA). *Proceedings of the 2000 IEEE international symposium on electronics and the environment*, San Francisco, CA, pp. 99-104.
- As with most DfX tools which improves design from just one perspective, DfEM only provides a singular view focusing on energy consumption during production. The reduction of energy consumption in the manufacture phase may have an adverse effect on the other stages of the life cycle.
- [16] Guinée, J. B., Gorree, M., Heijungs, R., Huppes, G., Kleijn, R., van Oers, L. et al., (2002) *Handbook on life cycle assessment-operational guide to the ISO standard*, Kluwer Academic Publishing., Dordrecht, The Netherlands
- [17] McAloone, T. C. (2000) *Industrial Application of Environmentally Conscious Design*, Professional Engineering Publishing, London.
- [18] Fitzgerald, D. P., Herrmann, J. W., Sandborn, P. A., Schimdt, L. C. and Gogoll, T. H. (2007) Design for Environment (DfE): Strategies, practices, guidelines, methods and tools, In *Environmentally Conscious Mechanical Design*(Ed, Kutz, M.) John Wiley & Sons, New Jersey.
- [19] Knight, P. and Jenkins, J. O. (2009) Adopting and applying eco-design techniques: a practitioners perspective, *Journal of Cleaner Production*, **17**, (5) 549-558.
- [20] Hauschild, M., Jeswiet, J. and Alting, L. (2005) From Life Cycle Assessment to Sustainable Production: Status and Perspectives, *CIRP Annals - Manufacturing Technology*, **54**, (2) 1-21.
- [21] Swiss Centre for Life Cycle Inventories, Ecoinvent, Available at: <http://www.ecoinvent.ch/> [Accessed 8 June 2010]
- [22] Granta Design Ltd. (2010), Available at: <http://www.grantadesign.com/> [Accessed 1 July 2010]
- [23] Optima Energy Management, Available at: <http://www.optimaenergy.net/> [Accessed 20 April 2010]
- [24] Boyd, G., Dutrow, E. and Tunnessen, W., (2008). The evolution of the ENERGY STAR® energy performance indicator for benchmarking industrial plant manufacturing use, *Journal of Cleaner Production*, **16**, 709-715
- [25] Kissock, K. J. and Eger, C. (2008) Measuring Industrial Energy Savings, *Applied Energy*, **85**, (5) 347-361.
- [26] Harvey, L. D. D. (2009) Reducing energy use in the buildings sector: measures, costs, and examples, *Energy Efficiency*, **2**, (2) 139-163.
- [27] Gutowski, T., J. Dahmus, and Thiriez, A., (2006). Electrical Energy Requirements for a Manufacturing Process. *Proceedings of 13th CIRP International Conference on Life Cycle Engineering*, Leuven, Belgium, 623-627
- [28] Herrmann, C. and Thiede, S. (2009) Process chain simulation to foster energy efficiency in manufacturing, *CIRP Journal of Manufacturing Science and Technology Life Cycle Engineering*, **1**, (4) 221-229.
- [29] Seow, Y. and Rahimifard, S., (2010). A Framework for Modelling Energy Consumption within Manufacturing Systems, *Proceedings of 43rd CIRP International Conference on Manufacturing Systems*, Vienna, Austria. pp. 222-227.
- [30] Rahimifard, S., Seow, Y. and Childs, T., (2010). Minimising Embodied Product Energy to support energy efficient manufacturing, *CIRP Annals - Manufacturing Technology*, **59**, (1) 25-28
- [31] Ashby, M. F., Miller, A., Rutter, F., Seymour, C. and Wegst, U. G. K. (2008). The CES Eco Selector –Background Reading, Granta Design Ltd., Cambridge.

Appendix 4

Journal Paper

A Framework for Modelling Energy Consumption within Manufacturing Systems

Introduction

This paper has been accepted for publication in the CIRP Journal of Manufacturing Science and Technology, April 2011

A Framework for Modelling Energy Consumption within Manufacturing Systems

Y. Seow and S. Rahimifard

Centre for Sustainable Manufacturing and Reuse/Recycling Technologies,
Loughborough University, UK

Abstract

Energy is an inextricable part of life in the 21st century, thus its availability and utilisation will become increasingly important with the concerns over climate change and the escalation in worldwide population. This highlights the need for manufacturing businesses to adopt the concept of 'lean energy' based on the use of the most energy efficient processes and activities within their production facilities. The energy consumption in manufacturing facilities can be reduced by either using more efficient technologies and equipment, and/or through improved monitoring and control of energy used in infrastructure and technical services. The research reported in this paper adopts a novel approach to modelling energy flows within a manufacturing system based on a 'product' viewpoint, and utilises the energy consumption data at 'plant' and 'process' levels to provide a breakdown of energy used during production.

Keywords:

Sustainable Development, Modelling, Energy Efficient Manufacturing

1 INTRODUCTION

Energy is the most fundamental resource for future economic growth and prosperity and its consumption is expected to continue to grow over the coming decades, with world energy demand estimated to be 45% higher in 2030 than today's levels [1]. The worldwide 'industrial' energy consumption is predicted to increase by 40% in 2030 from 2006 levels [2]. A study has suggested that this could be exacerbated by a potential shortfall in energy supply due to declining fossil based energy sources as shown in Figure 1 [3]. Furthermore, it is commonly reported that for the foreseeable future, the main source of power generation will be from fossil fuels [1, 2] and therefore the rationalisation of energy consumption still provides the most effective method of CO₂ reduction. Governments have consequently responded by introducing a number of energy related legislation, audits and accreditation. More recently European regulations have specifically addressed energy usage with the introduction of Directives such as Eco-Design of Energy using Products (EU Directive 2005/32/EC) and Energy End-Use Efficiency and Energy Services (EU Directive 2006/32/EC).

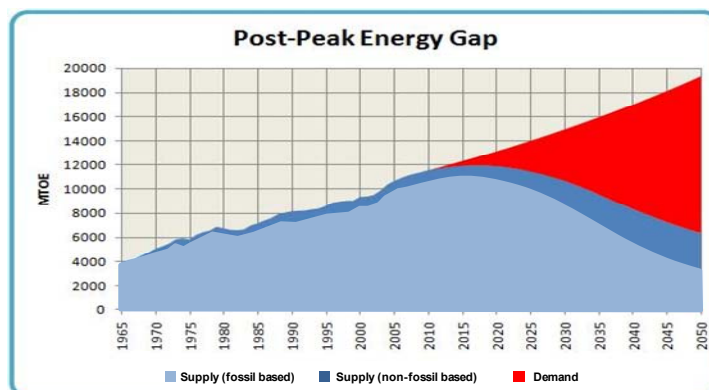

Figure 1: Growing gap between energy supply and demand. (Adapted from Chefurka [3])

Environmental practices and strategies in manufacturing businesses have changed over the past two decades, from simply meeting the regulations and legislative requirements to increasingly adopting a proactive approach in being environmentally responsible with respect to their products and processes.

Nowadays, environmental challenges are seen as competitive business opportunities rather than insurmountable cost burdens. It is therefore claimed that the increasing number of legislation and directives along with rising cost of fuel will provide significant impetus for manufacturers to reduce energy consumption.

The major research assertion made is that the efficiency and productivity of energy consumption in manufacturing applications has to be carefully examined, highlighting a need for methodologies and tools that can provide a detailed breakdown of energy usage within a manufacturing system. The authors believe that this work can support minimisation of energy consumption during manufacture and influence design decisions for even greater energy savings. This paper outlines a novel modelling framework to represent the total energy required to manufacture a unit product. The initial part of the paper provides a brief overview of existing research work in this area, with the main sections outlining the framework for modelling Embodied Product Energy (EPE) during manufacture and concludes with a case study that used discrete event simulation to establish the EPE.

2 A BRIEF REVIEW OF MOST RELEVANT RESEARCH

In recent years, there has been a significant growth in research activities directed at environmentally conscious/benign manufacturing [4,5] with a common aim of creating goods and services using processes and systems that are non-polluting, at the same time conserving energy and natural resources. The energy consumption is one of the main considerations within a Life Cycle Assessment (LCA) study [6], however due to the information intensive nature of LCA and the lack of accurate data related to energy demand across a product life cycle (in particular during the manufacturing phase), significant assumptions and simplifications are often made. This has motivated numerous research programmes to investigate energy consumption within a manufacturing facility so as to gain a better understanding of the energy use and breakdown.

The existing research in this area can be broadly viewed under two different perspectives of 'plant' and 'process' level. The first area, the 'plant' level perspective, has focused on the energy consumed by infrastructure and other high level services that are responsible for maintaining the required production conditions or environments. Examples of such energy consuming activities would be ventilation, lighting, heating and cooling within a facility [7]. Energy Management Systems (EMS) are commonly used to monitor these activities [8]. For example, Boyd [9] utilises a statistical analysis approach to determine the manufacturing Energy Performance Indicators based on 'plant level' variables. This work has been integrated into the American Energy Star performance rating system of manufacturing facilities.

On the other hand, the research targeting the energy consumption at the process level has concentrated on individual equipment, machinery and workstations within a production system. For example, as part of an international initiative on 'Cooperative Effort on Modelling Process Emissions in Manufacturing' (CO₂PE) [10], substantial research has been targeted to document, analyse and reduce process emissions for a wide range of available and emerging manufacturing processes [11,12]. The taxonomy used to structure the data is shown in Figure 2.

Overcash *et al.* [13] along with a group of other engineers are working to produce an engineering rule-of-practice-based analysis of separate unit processes used in manufacturing and the information is collated in the form of a unit process life cycle inventory (UPLCI) which would help the evaluation of manufactured products through the quantification of various parameters including: input materials, energy requirements, material losses and machine variables. Their work also uses a similar process taxonomy adopted by the CO₂PE initiative.

In addition, the process specific energy assessment investigated by Gutowski *et al.* [14] has taken a step further to develop generalised 'equipment-level' energy models, using average energy intensities of different manufacturing processes to evaluate the efficiency of processing lines. However, the considerations of energy flows at plant or process level cannot provide an overview of "how much energy is required to manufacture a unit product". The remaining sections of this paper will discuss a distinctly different approach based on a 'product' view which is not only capable of providing an estimation of total energy but also a breakdown of energy usage within the facility.

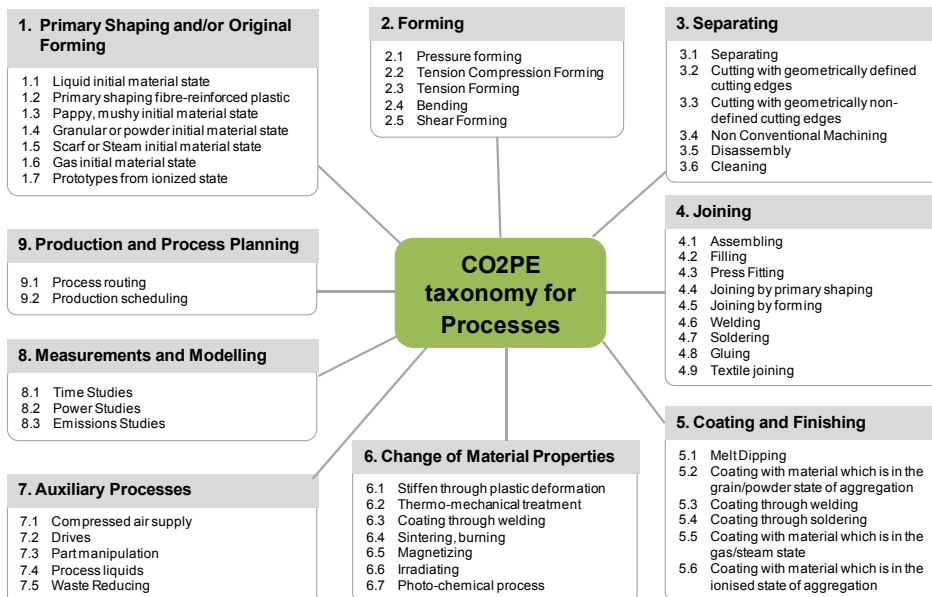

Figure 2: Taxonomy of Processes used by CO2PE. [10]

3 MODELLING ENERGY CONSUMPTION DURING MANUFACTURING PHASE

3.1 Product viewpoint for energy flow modelling

The proposed approach in this research is based on a product viewpoint and investigates the combination of energy used both at the plant and process levels, with the aim of representing the amount of energy attributed to the manufacture of a unit product, as depicted in Figure 3. The complexities, assumptions and simplifications typically included in a LCA study, highlights the need for such an approach when modelling EPE during the manufacturing phase.

3.2 Indirect and Direct Energy

In this approach, the energy consumed by various activities within a manufacturing application is categorised into two groups: Direct and Indirect Energy. The Direct Energy (DE) is defined as the energy used by various processes required to manufacture a product (e.g. casting, machining, spray painting, inspection etc.), whereas the Indirect Energy (IE) is the energy consumed by activities to maintain the 'environment' in which the production processes are carried out within the factory or manufacturing plant (e.g. lighting, heating and ventilation).

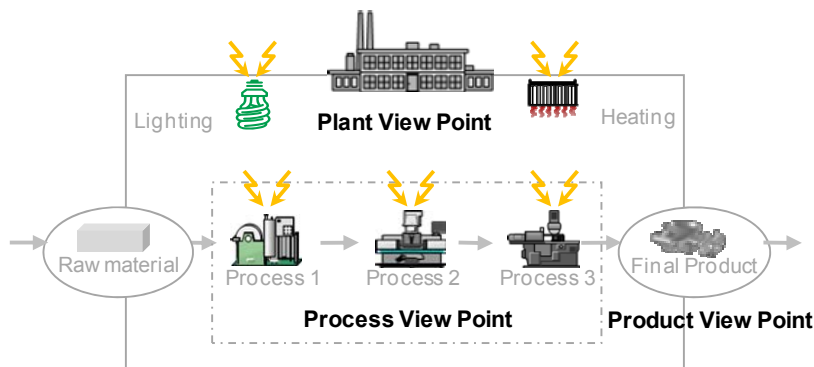

Figure 3: Plant, Process and Product Viewpoints to Energy Flow Modelling during Manufacture.

Further in the EPE framework, the DE is divided into: i) Theoretical Energy (TE) refers to the minimum energy required to carry out the process (e.g. energy required to melt a specific amount of metal during casting, or removing a specific amount of material during machining operation); and ii) Auxiliary Energy (AE) as the energy required by the supporting activities and auxiliary equipment for the process (e.g. generation of vacuum for sand casting, or pumping of coolant for machining). It should be noted that the value of AE also includes non-productive modes such as machine tool start-up, standby and cleaning.

In the case of IE, the energy consumed by various activities such as lighting and heating may be required by a number of processes, and/or a process may require specific environment (e.g. clean room for inspection). Therefore, in this approach, a manufacturing facility is considered as a number of 'zones' where a 'zone' is defined as an area within the manufacturing plant with similar indirect energy requirements.

The EPE model utilises data related to the DE and IE at both the 'plant' and 'process' levels to represent the total energy required to manufacture a product. The total embodied product energy is the sum of all the energy used by the processes required to manufacture the product and the energy consumed by the environment in which the processes are in, as illustrated in Figure 4. A combination of theory or empirical studies is required to determine the values of the DE and IE, as detailed in the next section.

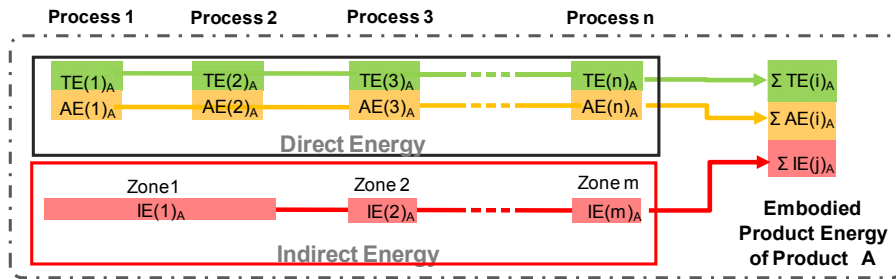

Figure 4: Framework for Modelling Embodied Product Energy.

3.3 Modelling Embodied Product Energy

A systematic approach has been used to calculate the DE and IE for various processes required in the production chain of a product. In most cases the value of the TE for a process can be calculated based on existing knowledge and/or appropriate mathematical models. Most of the traditional production processes depend on material removal, melting, vaporisation or deformation, and therefore the energy required can be determined through a number of specific process parameters. For example in the machining process, the TE can be calculated based on values for the specific cutting energy for the material, U , and volume of the material to be removed, V , i.e. $(U \times V)$. Likewise, the AE can be calculated based on system specifications (e.g. data from equipment manufacturers), and where data is unavailable, empirical studies can be conducted to measure energy required for the auxiliary processes. In the case of IE, the energy attributed to a product is calculated based on total energy consumed within a zone (per hour) divided by number of products processed in that 'zone' per hour. The sum of the TE and AE (i.e. the DE) together with the IE for all the processes within a production system represent the total embodied energy of the product, as illustrated in Figure 4. An example based on the machining of a simple part with the details of the calculations using the EPE framework is detailed in Seow and Rahimifard [15].

In this approach, the EPE model is not only able to detail the energy consumption for the various processes, but also highlights the energy hotspots within a manufacturing facility. Such energy intensive processes can then be examined to improve their efficiency or where possible be replaced with a less energy intensive process. In addition, more detailed assessments of the process efficiencies can be made by considering the ratio of TE to AE (with a higher value for TE and lower value for AE representing an energy efficient process) and similarly the ratio of DE to IE (with a higher value for DE and lower value for IE representing an energy efficient production system). Further details on the efficiency ratios can be found in Rahimifard and Seow [16]. The EPE model can also be used to examine the impact of other production parameters such as number of required setups, batch sizes, production schedules, etc. This could provide an insight into identifying optimum setup patterns and batch sizes, as well as opportunities to explore other causal factors that may affect the energy consumption of the processes.

3.4 Energy Simulation Model

The implementation of EPE framework within a practical application necessitates the development of a decision support tool, capable of representing the complexity involved in measuring, modelling and calculation of the DE (TE, AE) and IE for various processes in a typical production system. An energy simulation model is also required to establish 'what-if' scenarios for the analysis and evaluation of energy consumption during the manufacturing phase of a product life-cycle. Through the use of a simulation model, the manufacturing process flows can then be easily altered for different products and the model can be expanded to include product or process variations. Additional production variations such as batch sizing, lead times and queue times can also be included in the model.

The simulation model shown in Figure 5 has been based on a single production system and includes the various processes and manufacturing zones required to produce 3 different parts A, B and C. Subsets of data relating to Theoretical Energy are calculated by the simulation tool using appropriate mathematical models representing various processes (see the example case study). This calculated data is complemented with actual (real) data related to the Auxiliary Energy and Indirect Energy, recorded by advance metering devices and commercial energy management systems used within empirical studies. The manufacturing system has been modelled using software developed by Rockwell Automation called ArenaTM which is a general purpose, widely used software in both industry and academia [17]. It is a discrete event simulation and automation software and uses SIMAN processor and simulation language.

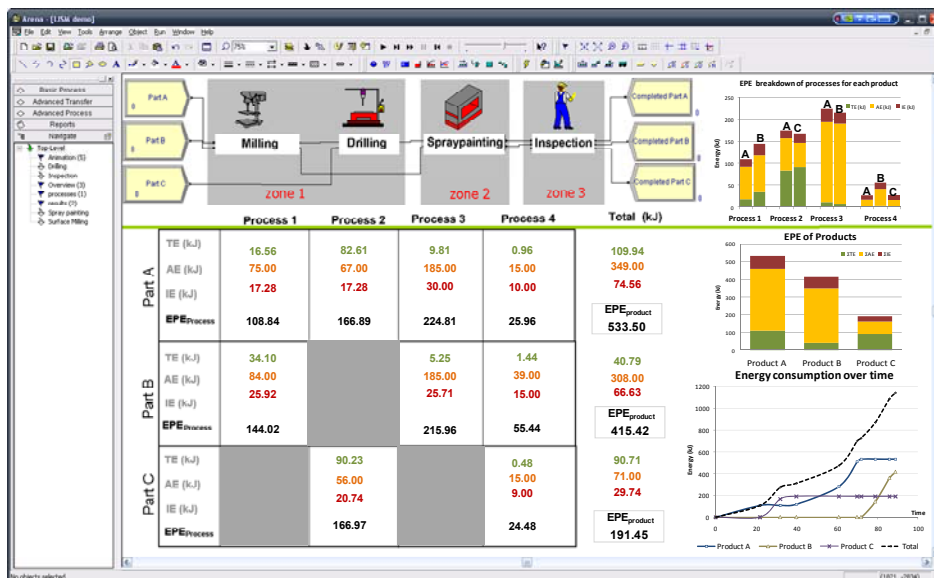

Figure 5: Screen print of the simulation model in ArenaTM showing details of the energy values and charts.

In the model, the manufacturing system comprises of 1 milling machine, 1 drilling machine, 1 spray painting booth and an ultrasonic inspection centre. The product is a metal component that comes in three variations. Part A is a milled part with several holes drilled in it; Part B is an asymmetrical profile that is milled and Part C is a square plate with one hole drilled in each corner. The production steps as well as the processing times are given in Figure 6. The parts each require different sets of processes and have different processing times. The parts are processed in batches of 10 and are assigned to the workstation once they become available.

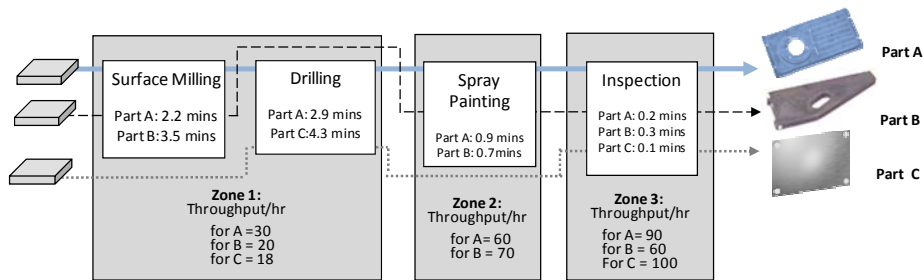

Figure 6: Simulation of energy flow during manufacture.

	1: Surface Milling	2: Drilling	3: Spray Painting	4: Inspection
TE	U*V U=specific cutting energy, kJ/mm ³ V= volume of material removed, mm ³		Determined empirically	$N_{trans} * P * T$ N _{trans} = number of transmitters P= power of transmitter (W) T= duration of use (sec)
AE	• Process liquids • Drives	• Process liquids • Drives	• Compressed air supply • Drives	• Part manipulation
IE	IEzone1/(Tzone1) IEzone1: Average IE consumed in the zone per hour (kJ/hr) Tzone 1: Throughput of Zone 1 (units/hr)		IEzone2/(Tzone2) IEzone2: Average IE consumed in the zone per hour (kJ/hr) Tzone 2: Throughput of Zone 2 (units/hr)	IEzone3/(Tzone3) IEzone3: Average IE consumed in the zone per hour (kJ/hr) Tzone 3: Throughput of Zone 4 (units/hr)

Table 1: Calculation of TE and AE for the casting process for the part.

The TE for the cutting processes – milling and drilling have been calculated based values for the specific cutting energy, U , and volume of material removed, V , using the equation ($U \times V$). Similarly for ultrasonic inspection, the values for the number of transmitters, N_{trans} , power of transmitter (P) and duration of transmission, T , were used to calculate the TE requirement, using the equation ($N_{trans} \times P \times T$). The TE for spray painting together with AE for all the other processes were determined empirically. In this example, the IE requirements were different due to the specific nature of each process; therefore 3 manufacturing zones have been defined for this application. The attribution of IE for a single part in each zone was calculated based on the total IE consumption per hour divided by the throughput for each zone. A summary of the equations and energy considerations is given in Table 1.

In this example, the IE requirements were different due to the specific nature of each process. Both the milling and drilling processes had similar requirements and so were grouped within the same zone. Individual zones were assigned for spray painting and inspection. The attribution of IE for a single part in each zone was calculated based on the total IE consumption per hour divided by the throughput per hour for each zone, which took into account waiting and queuing times, set-up times, part loading and unloading times, etc. It is argued that the inclusion of such miscellaneous (non-productive) times provides a greater degree of accuracy in the attribution of Indirect Energy to a product and enables further analysis of productive versus non-productive energy consumption. Where two processes share a zone as in the case of Product A, the IE consumed by each individual process in that zone is the average of the IE for zone 1 established for Product A. In this case, the IE of product A for zone 1 was found to be 34.56 kJ and therefore the IE for process 1 and 2 is $34.56/2 = 17.56$ kJ.

In this case study, Product A required the most amount of energy during manufacture followed by Product B and Product C, see Figure 7. Process 3 required the most energy and process 4 required the least energy. Both Products A and B can reduce its embodied product energy by eliminating Process 3. From a design perspective, this could provide an opportunity for designers to eliminate the need for a spray coating on the finished product, perhaps embracing the metallic look of the original material, thus reducing the embodied product energy. Alternatively, as much of the energy consumed in Process 3 is attributed to the auxiliary process, further studies can be conducted to identify inefficiencies in these auxiliary processes such as the compressed air system, thereby improving the efficiencies or if possible, eliminating them. In this case perhaps a variable motor could be installed for the compressed air system if only a small load is required.

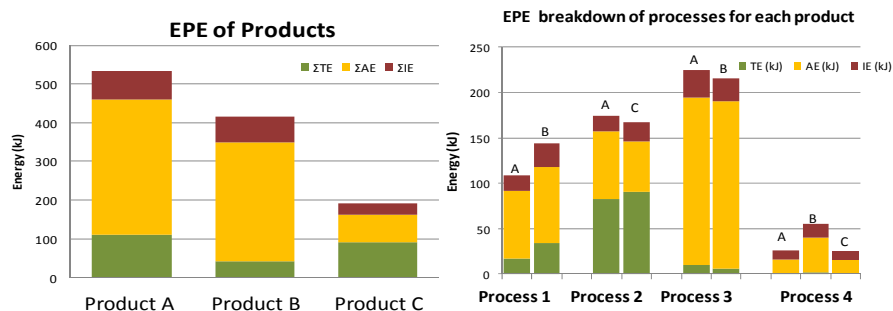

Figure 7: Results of Energy modelling showing EPE during the manufacturing phase for each product and for each process.

Clearly, the EPE framework not only provides an overview on how much energy is required to manufacture a unit product, but also enables further investigation of various factors that play a major influence on the energy consumption within a production system. Therefore it is argued that such energy simulation models can be used as effective decision tools to minimise the energy used during the operations and to support the implementation of 'Energy Efficient Manufacturing'.

It should be noted that with the flexibility offered by modern simulation tools, it is feasible to develop more complex models representing a larger production system for products that consist of a number of components. In such cases, the embodied energy for individual components is calculated and added together to represent the total EPE for the product assembly. Furthermore, the assembly and transportation activities can also be included in the EPE calculation if required. In a production system with automated assembly and/or transportation activities, the energy flows for these processes can be modelled like any other manufacturing workstation. However, the modelling of manual assembly and transportation activities present a particularly interesting challenge for the calculation of TE and DE due to a judgemental approach required for representing the energy consumption by a human operator. This is a commonly reported challenge for other lifecycle studies and one that needs further investigation.

The results from the modelling can also be used to support other tools such as the one recently developed by Duque Ciceri *et al.* [18] which estimates the material's embodied energy and manufacturing energy for a product for a quick life cycle energy analysis. The tool detailed in [18] uses data from a compilation of empirical studies, as such the EPE framework proposed in this paper could provide a structured approach for more energy studies to be conducted, thereby improving the accuracy of processing energy data available for use. Other possibilities of using simulation include process planning. For example, Chiotellis *et al.* [19] has used simulation to evaluate the energy consumption of various production plans. The energy model can also support operational improvements within the manufacturing facility by identifying energy intensive and/or energy inefficient direct processes and auxiliary processes.

However the authors believe the greatest energy savings through a product's lifecycle will come from product design as 90% of the lifecycle costs are determined in the design stage [20, 21]. Therefore this provides a great opportunity to further investigate the implementation of the EPE modelling framework within a Design for Energy Minimisation methodology as illustrated in Figure 8.

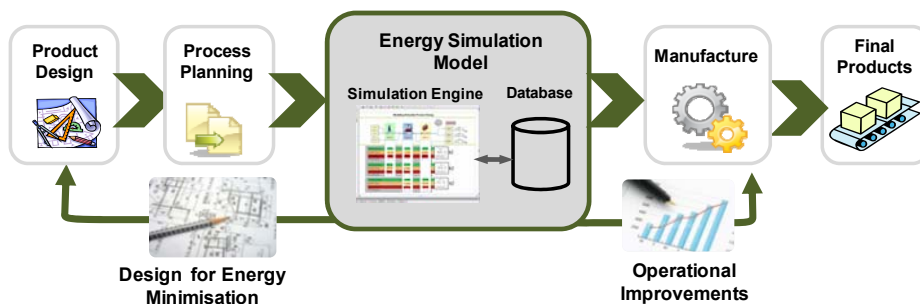

Figure 8: A 'Design for Energy Minimisation' approach

4 CONCLUDING REMARKS

The renewable energy technologies provides great potential for power generation in the long-term, however the rationalisation of energy consumption will still provide the greatest opportunity for CO₂ reduction in the short to medium term. In the longer term energy rationalisation may also benefit through reduced dependency and demand especially if renewable technologies continue to remain costly and unreliable. In addition, the expected rapid rise in the cost of energy together with increasing number of legislative and social requirements highlight the importance of adopting an 'energy efficient manufacturing' approach in future applications. The concept of 'lean energy' based on the use of the most energy efficient processes and activities within the production facilities is the most effective way of reducing energy costs whilst maintaining outputs.

Although a number of commercial tools have been utilised to track and monitor energy use in a factory and across various workstations, the detailed breakdown of energy consumption within various processes and, more importantly, its attribution to total energy required for the manufacture of a unit product is not well understood. This paper highlights the need for greater transparency of energy consumption across manufacturing processes and outlines a modelling framework to represent the 'Embodied Product Energy'. In addition to supporting operational decisions, the modelling of the EPE provides energy transparency right back to the design process, enabling designers to select the most energy efficient materials and processes whilst fulfilling the requirements of the product specification. Such a "Design for Energy Minimisation" approach will potentially enable businesses to go beyond the incremental improvements achievable via existing energy management systems to consider energy efficiency and utilisation across both the design and manufacturing phases of a product lifecycle.

Furthermore, LCA studies are data intensive and often based on assumptions inappropriate for the product being assessed. The energy model described in this paper could be integrated as part of the data provision, offering data that is of a greater degree of relevance in conjunction with predetermined databases (e.g. Ecoinvent), enabling a more accurate assessment of the product's impact during the manufacturing phase.

The next stage of the research will explore the implementation of the EPE framework within a simulation model capable of supporting complex 'what-if' scenarios during both the product development and operational planning, and also able to provide an estimation of energy required to manufacture a unit product.

5 REFERENCES

- [1] International Energy Agency, 2008, World Energy Outlook 2008, Available at: <http://www.worldenergyoutlook.org/2008.asp> [Accessed 15 September 2009].
- [2] Energy Information Administration, 2009, International Energy Outlook 2009, DOE/EIA-0484(2009), Available at: <http://www.eia.doe.gov/oiaf/ieo/industrial.html> [Accessed 10 August 2009].
- [3] Adapted from CHEFURKA, P. The looming energy shortfall. Available at: <http://paulchefurka.ca/EnergyGap.html> [Accessed 29 September 2010]
- [4] Rusinko, C.A., 2007, Green Manufacturing: An Evaluation of Environmentally Sustainable Manufacturing Practices and Their Impact on Competitive Outcomes, *Engineering Management* 54(3): 445-454.
- [5] Gutowski, T., Murphy, C., Allen, D., Bauer, D., Bras, B., Piwonka, T., Sheng, P., Sutherland, J., Thurston, D. and Wolff, E. 2005, Environmentally benign manufacturing: Observations from Japan, Europe and the United States. *Journal of Cleaner Production* 13(1): 1-17
- [6] Hauschild, M., Jeswiet, J. and Alting, L., 2005, From Life Cycle Assessment to Sustainable Production: Status and Perspectives. *CIRP Annals - Manufacturing Technology*, 54(2):1-21.
- [7] Moss, K. J., 2006 *Energy Management in Buildings*, 2nd Edition, Taylor & Francis, London.
- [8] Somervell, D. (Ed.), 1991. *Educated Energy Management*, E&FN Spon, London, UK.
- [9] Boyd, G., Dutrow, E. and Tunnessen, W., 2008, The evolution of the ENERGY STAR® energy performance indicator for benchmarking industrial plant manufacturing use, *Journal of Cleaner Production* 16: 709-715.
- [10] Katholieke Universiteit Leuven, CO₂PE, Available at: <http://www.mech.kuleuven.be/co2pe/i/index.php> [Accessed: 08 March 2009].
- [11] Devoldere, T., Dewulf, W., Deprez, W., Willems, B., Dufloy, R.J. 2007, Improvement Potentials for Energy Consumption in Discrete Part Production Machines. *Proceedings 14th CIRP Conference on Life Cycle Engineering*, Tokyo, Japan. pp. 311-316.
- [12] Herrman, C., Bergmann, L., Thiede, S., Zein, A., 2007, Energy Labels for Production Machines - An Approach to Facilitate Energy Efficiency in Production Systems. *Proceedings of 40th CIRP International Seminar on Manufacturing Systems*, Liverpool, UK.
- [13] Overcash, M., Twomey, J. and Kalla, D., 2009. Unit Process Life Cycle Inventory for Product Manufacturing Operations, *ASME International Manufacturing Science and Engineering Conference*, West Lafayette, IN, USA.
- [14] Gutowski, T., J. Dahmus, et al., 2006, Electrical Energy Requirements for a Manufacturing Process. *Proceedings of CIRP International Conference on Life Cycle Engineering 2006*, Leuven, Belgium.

- [15] Seow, Y. and Rahimifard, S., 2010. A Framework for Modelling Energy Consumption within Manufacturing Systems, *Proceedings of 43rd CIRP International Conference on Manufacturing Systems*, Vienna, Austria. pp. 222-227.
- [16] Rahimifard, S., Seow, Y. and Childs, T., 2010. Minimising Embodied Product Energy to support energy efficient manufacturing, *CIRP Annals - Manufacturing Technology*, **59**, (1) 25-28.
- [17] Bapat, V. and Sturrock, D. T., 2003. The Arena Product Family: enterprise modeling solutions, *Proceedings of the 2003 Winter Simulation Conference*, pp. 210-217.
- [18] Duque Ciceri, N., Gutowski, T. G. and Garetti, M., 2010. A tool to estimate materials and manufacturing energy for a product, *2010 IEEE International Symposium on Sustainable Systems and Technology (ISSST)*, pp. 1-6.
- [19] Chiotellis, S., Weinert, N. and Seliger, G., 2010. Simulation-based, energy-aware production planning, *Proceedings of 43rd CIRP International Conference on Manufacturing Systems*, Vienna, Austria, pp. 165-172.
- [20] Roche, T., 2004. The Design for Environmental Compliance Workbench Tool, In *Product Engineering* (Eds, Talaba, D. and Roche, T.) Springer, Netherlands, pp. 3-16.
- [21] Howard, L. and Lewis, H., 2003. The development of a database system to optimise manufacturing processes during design, *Journal of Materials Processing Technology*, **134**, 374-382.

Appendix 5

Conference Paper

A Framework for Modelling Energy Consumption within Manufacturing Systems

Introduction

This paper was presented at the 43rd CIRP International Conference on Manufacturing Systems, Vienna, Austria, 26th -28th May 2010.

A Framework for Modelling Energy Consumption within Manufacturing Systems

Y. Seow and S. Rahimifard

Centre for Sustainable Manufacturing and Reuse/Recycling Technologies
Loughborough University

Abstract

Energy is an inextricable part of life in the 21st century, thus its availability and utilisation will become increasingly important with the concerns over climate change and the escalation in worldwide population. This highlights the need for manufacturing businesses to adopt the concept of 'lean energy' based on the use of the most energy efficient processes and activities within their production facilities. The energy consumption in manufacturing facilities can be reduced by either using more efficient technologies and equipment, and/or through improved monitoring and control of energy used in infrastructure and technical services. The research reported in this paper adopts a novel approach to modelling energy flows within a manufacturing system based on a 'product' viewpoint, and utilises the energy consumption data at 'plant' and 'process' levels to provide a breakdown of energy used during production.

Keywords:

Sustainable Development, Environmental, Energy Efficient Manufacturing

1 INTRODUCTION

Energy is the most fundamental resource for future economic growth and prosperity and its consumption is expected to continue to grow over the coming decades, with energy demand estimated to be 45% higher in 2030 than today's levels, as depicted in Figure 1 [1]. The worldwide 'industrial' energy consumption is predicted to grow from 175.0 quadrillion Btu in 2006 to 245.6 quadrillion Btu in 2030 [2]. Furthermore, it is commonly reported that for the foreseeable future the main source of power generation will be from fossil fuels and therefore the rationalisation of energy consumption still provides the most effective method of CO₂ reduction. Governments have consequently responded by introducing a number of energy related legislation, energy auditing and accreditation. More recently European regulations have specifically addressed energy usage with the introduction of Directives such as Eco-Design of Energy using Products (EU Directive 2005/32/EC) and Energy End-Use Efficiency and Energy Services (EU Directive 2006/32/EC).

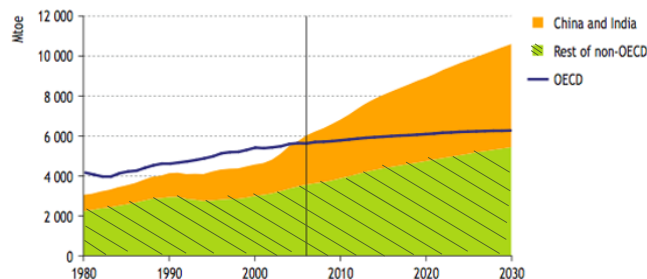

Figure 1: Increase in world primary energy demand by region.
(source: World Energy Outlook[1])

Environmental practices and strategies in manufacturing businesses have changed over the past two decades, from simply meeting the regulations and legislative requirements to increasingly adopting a proactive approach in being environmentally responsible with respect to their products and processes. Nowadays, the environmental challenges are seen as competitive business opportunities rather than insurmountable cost burdens. It is therefore claimed that the increasing number of legislation and directives along with rising cost of fuel will provide significant impetus for manufacturers to reduce energy consumption.

The major research assertion made is that the efficiency and productivity of energy consumption in manufacturing applications has to be carefully examined, highlighting a need for methodologies and tools that can provide a detailed breakdown of energy usage within a manufacturing system. This paper outlines a novel modelling framework to represent the total energy required to manufacture a unit product. The initial part of the paper provides a brief overview of existing research work in this area, with the main sections outlining the framework for modelling of Embodied Product Energy (EPE) during manufacture.

2 A BRIEF REVIEW OF MOST RELEVANT RESEARCH

In recent years, there has been a significant growth in research activities directed at environmentally conscious/benign manufacturing [3,4] with a common aim of creating goods and services using processes and systems that are non-polluting, at the same time conserving energy and natural resources. The energy consumption is one of the main considerations within a Life Cycle Assessment (LCA) [5] study, however due to the information intensive nature of an LCA and the lack of accurate data related to energy demand across a product life cycle (in particular during the manufacturing phase), in most cases significant assumptions and simplifications are often made. Therefore, there have been a number of research programmes that have attempted to investigate the energy consumption within a manufacturing facility. These can be broadly viewed under two different perspectives of 'plant' and 'process' level. The work directed at plant level consideration has focused on the energy consumed by infrastructure and other high level services that are responsible for maintaining the required production conditions/environment.

Examples of such energy consuming activities would be ventilation, lighting, heating and cooling within a facility [6]. Energy Management Systems (EMS) are commonly used to monitor these activities [7]. For example, Boyd utilises a statistical analysis approach to determine the manufacturing Energy Performance Indicators based on 'plant level' variables. This work has been integrated into the American Energy Star performance rating system of manufacturing facilities [8].

On the other hand, the research targeting the energy consumption at process level has concentrated on individual equipment, machinery, and workstation within a production system. For example, as part of an international initiative on 'Cooperative Effort on modelling Process Emissions in manufacturing (CO₂PE) [9], substantial research has been targeted to document, analyse and reduce process emissions for a wide range of available and emerging manufacturing processes [10,11]. In addition, the process specific energy assessment investigated by Gutowski *et al.* [12] has taken a step further to develop generalised 'equipment-level' energy models, using average energy intensities of different manufacturing processes to evaluate the efficiency of processing lines. However, the considerations of energy flows at plant or process level cannot provide an overview of "how much energy is required to manufacture a unit product". The remaining sections of the paper discuss a distinctly different approach based on a 'product' view which is not only capable of providing an estimation of total energy but also a breakdown of energy usage within the facility.

3 MODELLING ENERGY CONSUMPTION DURING MANUFACTURING PHASE

3.1 Product viewpoint for energy flow modelling

The proposed approach based on product viewpoint investigates the combination of energy used both at the plant and process levels, and aims to represent the amount energy attributed to the manufacture of a unit product, as depicted in Figure 2. The complexities, assumptions and simplifications typically included in a LCA study, highlights the need for such approach on modelling EPE during the manufacturing phase.

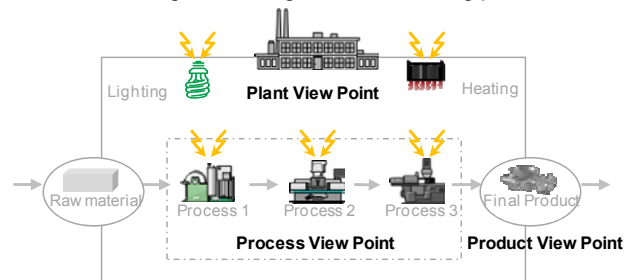

Figure 2: Plant, Process and Product Viewpoints to Energy Flow Modelling during Manufacture.

3.2 Indirect and Direct Energy

In the proposed approach, the energy consumed by various activities within a manufacturing application are categorised into two groups: Direct and Indirect Energy. The Direct Energy (DE) is defined as the energy used by various processes (e.g. casting, machining, spray painting, inspection etc.) required to manufacture a product, whereas the Indirect Energy (IE) is the energy consumed by activities (e.g. lighting, heating and ventilation) to maintain the 'environment' in which the production processes are carried out within the factory or manufacturing plant.

Similarly in the EPE framework, the DE has been divided into: i) Theoretical Energy (TE) which is the minimum energy required to carry out the process (e.g. energy required to melt a specific amount of metal during casting, or removing a specific amount of material during machining operation); ii) Auxiliary Energy (AE) which is the energy required by the supporting activities and auxiliary equipment for the process (e.g. generation of vacuum for sand casting, or pumping of coolant for machining). It should be noted that the value of AE also includes any non-productive modes such as machine tool start-up, standby and cleaning.

In the case of IE, the energy consumed by various activities such as lighting and heating may be required by a number of processes, and/or a process may require specific environment (e.g. clean room for inspection). Therefore, in this approach a manufacturing facility is considered as a number of 'zones' where a 'zone' is defined as an area within the manufacturing plant with similar indirect energy requirements.

The EPE model utilises data related to the DE and IE at both the 'plant' and 'process' levels to represent the total energy required to manufacture a product, as shown in Figure 3. A combination of theory or empirical studies is required to determine the values of the DE and IE, as detailed in the next section.

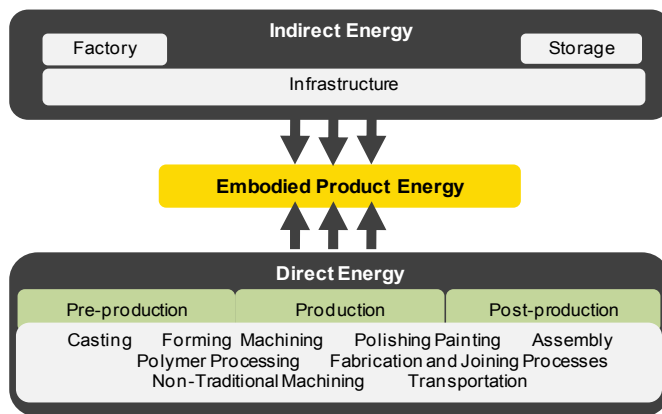

Figure 3: Framework for Modelling Embodied Product Energy.

3.3 Modelling Embodied Product Energy

A systematic approach has been used to calculate the DE and IE for various processes required in the production chain of a product. In most cases the value of the TE for a process can be calculated based on existing knowledge and/or appropriate mathematical models. Most of the traditional production processes depend on melting, vaporisation or deformation, and therefore the energy required can be determined through a number of specific process parameters. For example in the casting process, the TE can be calculated based on values for the latent heat of melting of the material (L), specific heat capacity of the material (C), temperature of the material (T), melting temperature of the material (T_m) and finally, mass of the material (m), i.e. $mC(T_m - T) + mL$. Likewise, the AE can be calculated based on system specifications (e.g. data from equipment manufacturers), and where data is unavailable, empirical studies can be conducted to measure energy required for the auxiliary processes. In the case of IE, the energy attributed to a product is calculated based on total energy consumed within a zone (per hour) divided by number of products processed in that 'zone' per hour. The sum of the TE and AE (i.e. the DE) together with the IE for all the processes within a production system represent the total embodied energy of the product, as illustrated in Figure 4.

In this approach, the EPE model is not only able to detail the energy consumption for the various processes, but also highlights the energy hotspots within a manufacturing facility. Such energy intensive processes can then be examined to improve their efficiency or where possible be replaced with a less energy intensive one. In addition, more detailed assessments of the process efficiencies can be made by considering the ratio of TE to AE (with a higher value for TE and lower value for AE representing an energy efficient process) and similarly the ratio of DE to IE (with a higher value for DE and lower value for IE representing an energy efficient production system). The EPE model can also be used to examine the impact of other production parameters such as number of required set ups, batch sizes, production schedules, etc. This could provide an insight into identifying optimum set up patterns and batch sizes, as well as opportunities to explore other causal factors that may affect the energy consumption of the processes.

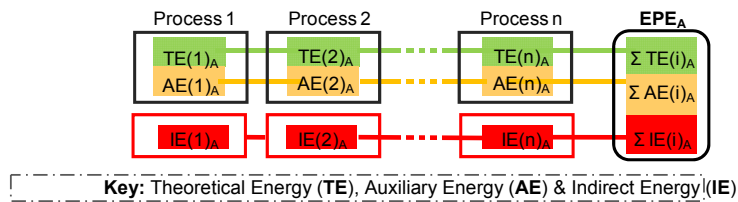

Figure 4: Depiction of EPE of Product 'A' produced using n processes.

3.4 An Example of the application of EPE

A simple part requiring only the machining process is used to demonstrate the application of EPE modelling. The part is made from aluminium alloy with an output rate of 30 parts per hour from the machining shop used in this example. The production of the part involves traditional machining of a pocket in the middle with some grooves and slots to indicate a football pitch and four holes on each end. The TE was calculated based on the specific cutting energy of the material, U (kJ/mm^3) and the volume of material removed, V (mm^3). The AE was established through measuring the energy consumption of the milling machine and its auxiliary equipments such as pumping of coolant and other non machining activities (e.g. set up, tool change, controller etc.). The IE was determined through the overall indirect energy consumption for the zone, in this case 4 sets of florescent lights in the machining shop (each tube with a 240v, 36W rating). Finally, based on the throughput of 30 parts per hour, the time in machining zone was determined to be 2 minutes. The calculations for the TE, AE and IE are summarised in Figure 6. In this example, the AE clearly consumes the greatest proportion of total energy at 60%, followed by the IE at 21%, and in fact the TE represents the least amount of the 'Embodied Product Energy' (i.e. 19%).

The authors claim that this EPE modelling framework provides a great opportunity to further investigate factors that play a role in the energy consumption during the manufacturing of a product. The implementation of the EPE framework with a decision support tool to minimise energy consumption in manufacturing applications represents the next phase of the research.

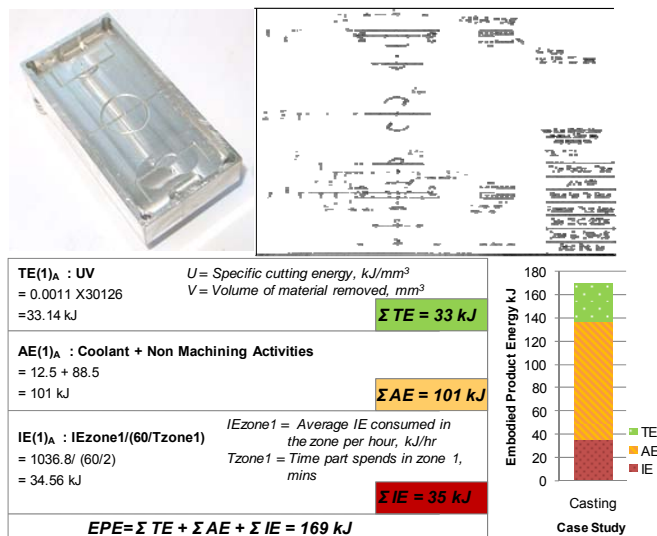

Figure 5: Calculation of TE and AE for the casting process for the part.

4 CONCLUDING REMARKS

The renewable energy technologies provides great potential for power generation in the long-term, however the rationalisation of energy consumption will still provide the greatest opportunity for CO₂ reduction in the short to medium term. In addition, the expected rapid rise in the cost of energy together with increasing number of legislative and social requirements highlight the importance of adopting an 'energy efficient manufacturing' approach in future applications. The concept of 'lean energy' based on the use of the most energy efficient processes and activities within the production facilities is the most effective way of reducing energy costs whilst maintaining outputs.

Although a number of commercial tools have been utilised to track and monitor energy use in a factory and across various workstations, the detailed breakdown of energy consumption within various processes and more importantly its attribution to total energy required for the manufacture of a unit product is not well understood. This paper highlights the need for greater transparency of energy consumption across manufacturing processes and outlines a modelling framework to represent the 'Embodied Product Energy'. In addition to supporting operational decisions, the modelling of the EPE provides energy transparency right back to the design process, enabling designers to select the most energy efficient materials and processes whilst fulfilling the requirements in the product specification, as depicted in Figure 6. Such a "Design for Energy Minimisation" approach will potentially enable businesses to go beyond the incremental improvements achievable via existing energy management systems to consider energy efficiency and utilisation across both the design and manufacturing phases of a product life cycle.

Furthermore, LCA studies are data intensive and often based on assumptions inappropriate for the product being assessed, the energy model described in this paper could be integrated as part of the data provision, offering data that is of a greater degree of relevance in conjunction with predetermined databases (e.g. Ecoinvent), enabling a more accurate assessment of the product's impact during the manufacturing phase.

The next stage of the research will explore the implementation of the EPE framework within a simulation model capable of supporting complex 'what-if' scenarios during both the product development and operational planning, and also able to provide an estimation of energy required to manufacture a unit product.

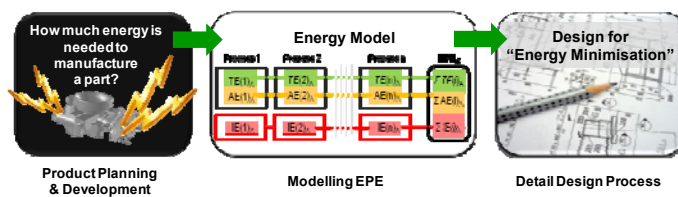

Figure 6: A 'Design for Energy Minimisation' approach

5 REFERENCES

- [1] International Energy Agency, 2008, World Energy Outlook 2008, Available at: <http://www.worldenergyoutlook.org/2008.asp> [Accessed 15 September 2009].
- [2] Energy Information Administration, 2009, International Energy Outlook 2009, DOE/EIA-0484(2009), Available at: <http://www.eia.doe.gov/oiaf/ieo/industrial.html> [Accessed 10 August 2009].
- [3] Rusinko, C.A., 2007, Green Manufacturing: An Evaluation of Environmentally Sustainable Manufacturing Practices and Their Impact on Competitive Outcomes, *Engineering Management* 54(3): 445-454.
- [4] Gutowski, T., Murphy, C., Allen, D., Bauer, D., Bras, B., Piwonka, T., Sheng, P., Sutherland, J., Thurston, D. and Wolff, E. 2005, Environmentally benign manufacturing: Observations from Japan, Europe and the United States. *Journal of Cleaner Production* 13(1): 1-17
- [5] Hauschild, M., Jeswiet, J. and Alting, L., 2005, From Life Cycle Assessment to Sustainable Production: Status and Perspectives. *CIRP Annals - Manufacturing Technology*, 54(2):1-21.
- [6] Moss, K. J., 2006 *Energy Management in Buildings*, 2nd Edition, Taylor & Francis, London.
- [7] Somervell, D. (Ed.), 1991. *Educated Energy Management*, E&FN Spon, London, UK.
- [8] Boyd, G., Dutrow, E. and Tunnessen, W., 2008, The evolution of the ENERGY STAR® energy performance indicator for benchmarking industrial plant manufacturing use, *Journal of Cleaner Production* 16: 709-715.
- [9] Katholieke Universiteit Leuven, CO₂PE, Available at: <http://www.mech.kuleuven.be/co2pe/index.php> [Accessed: 08 March 2009].
- [10] Devoldere, T., Dewulf, W., Deprez, W., Willems, B., Duflou, R.J. 2007, Improvement Potentials for Energy Consumption in Discrete Part Production Machines. *Proceedings 14th CIRP Conference on Life Cycle Engineering*, Tokyo, Japan. pp. 311-316.
- [11] Herrman, C., Bergmann, L., Thiede, S., Zein, A., 2007, Energy Labels for Production Machines - An Approach to Facilitate Energy Efficiency in Production Systems. *Proceedings of 40th CIRP International Seminar on Manufacturing Systems*, Liverpool, UK.
- [12] Gutowski, T., J. Dahmus, et al., 2006, Electrical Energy Requirements for a Manufacturing Process. *Proceedings of CIRP International Conference on Life Cycle Engineering 2006*, Leuven, Belgium.

Appendix 6

Journal Paper

Minimising Embodied Product Energy to support energy efficient manufacturing

Introduction

This paper has been accepted for publication in the CIRP Annals – Manufacturing Technology, January 2010

Minimising Embodied Product Energy to Support Energy Efficient Manufacturing

S. Rahimifard¹, Y.Seow¹ and / T. Childs (1)

The Centre for Sustainable Manufacturing And Reuse/Recycling Technologies (SMART),

Loughborough University, Loughborough, LE11 3TU, United Kingdom

Abstract

Green sources of power generation and efficient management of energy demand are among the greatest challenges facing manufacturing businesses. A significant proportion of energy used in manufacturing is currently generated through fossil fuels. Therefore in the foreseeable future, the rationalisation of energy consumption still provides the greatest opportunity for reduction of greenhouse gases. A novel approach to energy efficient manufacturing is proposed through modelling the detailed breakdown of energy required to produce a single product. This approach provides greater transparency on energy inefficiencies throughout a manufacturing system and enables a 20-50% reduction of energy consumption through combined improvements in production and product design.

Keywords: Sustainable Development, CO₂ Emission, Energy Efficient Manufacturing

1 INTRODUCTION

Energy is a key component in the development of modern society; it promotes economic growth and improves the quality of life. The escalation in worldwide population has contributed to the rising energy consumption, and demand levels are estimated to be 45% higher in 2030 than current levels [1]. As a consequence of our strong dependence on energy, there is a growing concern about energy availability and its environmental impacts. Much of our electricity is still generated from carbon based sources such as coal, oil and gas (see Figure 1) which accounts for more than half of the world's greenhouse gas emissions [2]. This has led to governments introducing an array of environmental legislation, energy auditing and accreditation standards. Therefore, energy demand and its rationalisation are now gaining greater visibility within modern manufacturing businesses. Improving energy efficiency is not only one of the most significant ways to reduce the overall environmental impacts, but could also represent substantial cost savings and competitive advantages [3].

The research reported in this paper highlights the need for appropriate methods and tools within manufacturing businesses that can provide a breakdown of energy usage within their production facilities, and enabling them to assess the efficiency and productivity of their energy consumption. The paper outlines a novel modelling framework to represent the total energy required to manufacture a unit product. A case study has been used to demonstrate how product and production efficiencies can be assessed using this Embodied Product Energy (EPE) model.

2 A FRAMEWORK FOR MODELLING EMBODIED PRODUCT ENERGY DURING MANUFACTURE

A number of modelling approaches have been used to investigate the energy consumption within a manufacturing facility.

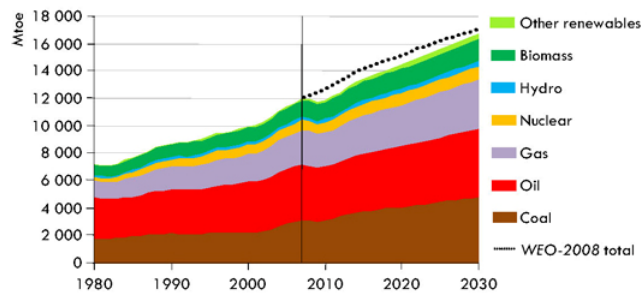

Figure 1: World primary energy demand by fuel [4]

These can be viewed under two generic perspectives of ‘plant’ and ‘process’ levels. At the ‘plant’ level, most of the research work has focused on modelling and reducing the energy consumed by infrastructure and other high level services (e.g. ventilation, lighting, heating and cooling) which are responsible for maintaining the required production conditions/environment [5,6]. On the other hand, research on the ‘process’ level has focused on modelling the energy consumption of equipment, machinery and workstations in production facilities [7,8]. Whilst these areas of research have identified various methods for improving energy used by buildings, technical services and production processes [9], it is argued that the independent considerations of energy consumption at ‘plant’ and ‘process’ levels are unable to provide an overview of “how much energy is required to manufacture a unit product?”.

At present, the energy considerations from the ‘product’ viewpoint are included as part of the Life Cycle Assessment (LCA) studies. However, the data intensive nature of a LCA coupled with the lack of accurate data related to the energy consumption across a product life-cycle often results in significant assumptions and simplifications [10], thus highlighting the need for a more holistic approach on modelling EPE during the manufacturing phase. The proposed framework aims to represent the amount of energy attributed to the manufacture of a unit product through the integration of energy used both at the ‘plant’ and ‘process’ levels. This modelling approach could further support detailed LCA studies,

providing a greater insight into the energy consumption during the manufacturing phase of a product life-cycle.

In the EPE framework, the energy consumed by various activities within a manufacturing application is categorised into two groups: Direct and Indirect Energy. The Direct Energy (DE) is defined as the energy used by various processes (e.g. casting, machining, spray painting, inspection, etc.) required to manufacture a product, whereas the Indirect Energy (IE) is the energy consumed by activities (e.g. lighting, heating, ventilation, etc.) to maintain the ‘environment’ in which the production processes are carried out within a manufacturing plant. Furthermore in this framework, the DE has been divided into : i) Theoretical Energy and ii) Auxiliary Energy, as depicted in Figure 2. The Theoretical Energy (TE) is defined as the minimum energy required to carry out the process (e.g. energy required to melt a specific amount of metal during casting or removing a specific amount of material during a machining operation). In most cases, the value of the TE for a process can be calculated based on existing knowledge and/or appropriate mathematical models (e.g. the total energy for Grinding (U_{total}) based on specific energies of ploughing (U_{pl}), chip formation (U_c), primary rubbing (U_{pri_r}), and secondary rubbing (U_{sec_r}), using the equation $U_{total}=0.5(U_{pl}+U_c)+U_{pri_r}+U_{sec_r}$) [11].

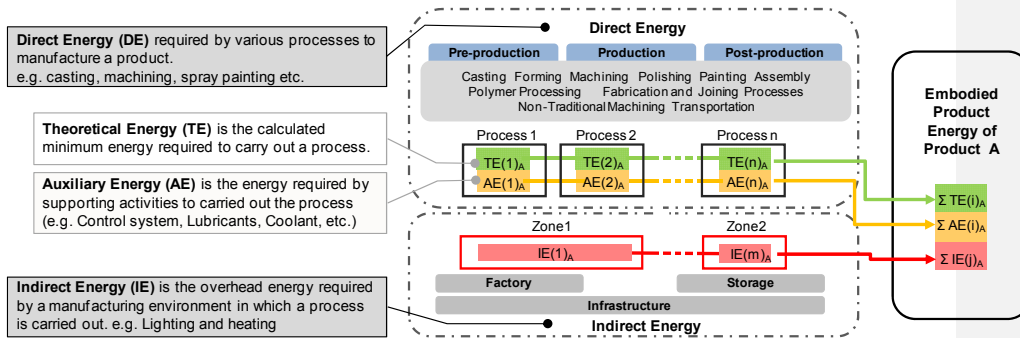

Figure 2: The Embodied Product Energy Framework for Modelling Energy Flows during Manufacture

The Auxiliary Energy (AE) is the energy required by the supporting activities and auxiliary equipment for the process (e.g. generation of vacuum for sand casting or pumping of coolant for machining). The AE for a process can often be determined or measured through empirical studies. Therefore the total Direct Energy consumed by product A , requiring n processes can be represented as :

$$DE_A = \sum_{i=1}^n (TE(i)_A + AE(i)_A) \quad [1]$$

In the case of IE, the energy consumed by various activities such as lighting and heating maybe used by a number of processes or in some applications a process may require specific processing environment (e.g. clean room for inspection). Therefore within the EPE framework, a production facility is considered as a number of zones where a ‘zone’ is defined as an area within the manufacturing plant with similar Indirect Energy requirements. This is comparable to defining cells or departments within a traditional production system based on similarity of processes (e.g. a machining cell) or products (e.g. a food production line),

except that in this case the grouping of activities is based on similarity of Indirect Energy requirements. In this approach, the IE attributed to product A in zone m (i.e. $IE_{zone(m)_A}$) can be calculated based on total Indirect Energy consumed within zone m per hour (i.e. $IE_{zone(m)}$) divided by the total number of product A processed in that zone per hour (i.e. $60/T_{zone(m)_A}$), where $T_{zone(m)}$ is the time product A spends in zone m , as expressed in Equation 2 :

$$IE_{zone(m)_A} = IE_{zone(m)} / \left[\frac{60}{T_{zone(m)_A}} \right] \quad [2]$$

Consequently, the total Indirect Energy required by product A requiring m manufacturing zones can be represented as:

$$IE_A = \sum_{j=1}^m IE_{zone(j)_A} \quad [3]$$

Finally, the total Embodied Product Energy during the manufacturing phase of product A life cycle can be calculated by summing the DE for n processes together with the IE for m zones within a production system, as depicted below:

$$EPE_A = \sum_{i=1}^n DE(i)_A + \sum_{j=1}^m IE_{zone(j)_A} \quad [4]$$

Furthermore, a number of ratios of TE, DE, and IE have been identified in order to assess and analyse the efficiency of processes, products and production systems. For example, the ratio of TE over DE (see Equation 5) is referred to as the 'Efficiency Ratio for a process ($ER_{process}$)' and can be used to analyse the productivity of a process, as shown in Figure 3. Ideally where possible, the Auxiliary Energy for a process should be minimised as the AE can often be considered as non value-added energy consumption. Therefore, a higher value of $ER_{process}$ (i.e. values closer to 1) is indicative of a very efficient process. Similarly, the ratio of TE over EPE is defined as the 'Efficiency Ratio for a product ($ER_{product}$)' and the ratio of DE over EPE is referred to as 'Efficiency Ratio for a production system ($ER_{production}$)', as depicted in Equations 6 and 7. The higher value of $ER_{product}$ (i.e. values closer to 1) indicates a higher efficiency of energy consumption during the manufacture of a product, due to minimal energy being used through AE and IE in producing the product. Finally, the $ER_{production}$ can be used to analyse the productivity of a manufacturing system where a higher value (i.e. values closer to 1) is indicative of effective use of energy during production, as the IE can also be considered as non value-added energy consumption.

$$0 < ER_{process} = \frac{TE}{DE} < 1 \quad [5]$$

$$0 < ER_{product} = \frac{TE}{EPE} < 1 \quad [6]$$

$$0 < ER_{production} = \frac{DE}{EPE} < 1 \quad [7]$$

3 ENERGY SIMULATION MODEL

The implementation of EPE framework within a practical application necessitates the development of a decision support tool, capable of representing the complexity involved in modelling and calculation of the AE, TE, DE and IE for various processes in a typical production system. An energy simulation model (see Figure 4) has been developed to allow a number of ‘what-if’ scenarios for the analysis and evaluation of energy consumption during the manufacturing phase of a product life-cycle.

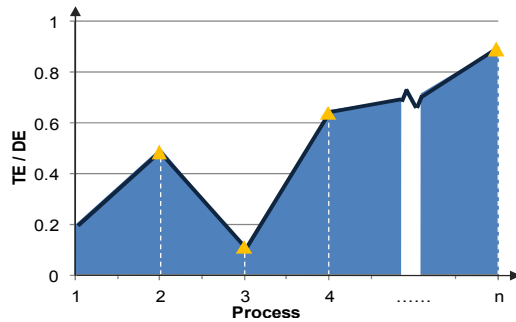

Figure 3: The Efficiency Ratio for a Process

The simulation model shown in Figure 4 has been based on a single production system and includes the various processes and manufacturing zones required to produce a simple product. A subset of data related to Theoretical Energy is calculated by the simulation tool using appropriate mathematical models representing various processes (see the example case study). This calculated data is complemented with actual (real) data related to the Auxiliary Energy and Indirect Energy, recorded by advance metering devices and commercial energy management systems used within empirical studies.

It should be noted that with the flexibility offered by modern simulation tools, it is feasible to develop more complex models representing a larger production system for products that consist of a number of components.

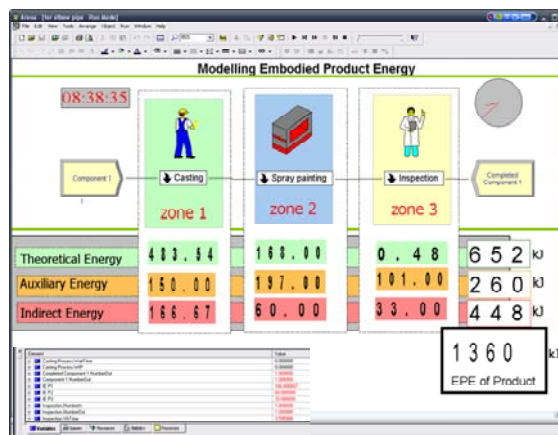

Figure 4: Simulation of Energy Flow Modelling during Manufacture

In such cases, the embodied energy for individual components are calculated and added together to represent the total EPE for the product assembly. Furthermore if required, the assembly and transportation activities can also be included in the EPE calculation. In production system with automated assembly and/or transportation activities, the energy flows for these processes can be modelled like any other manufacturing workstation. However, the modelling of manual assembly and transportation activities present a particularly interesting challenge for the calculation of Theoretical and Direct Energies due to a judgemental approach required for representing the energy consumption by a human operator. This is a commonly reported challenge for other life-cycle studies and one that needs further investigation.

One of the main objectives proposed for the practical use of such energy simulation models is to increase their accuracy and resolution using a number of case study products (i.e. to train the models), so that they could be used as a design support tool capable of 'predicting' energy requirements for new product designs in various applications, as will be discussed later in the paper.

4 AN EXAMPLE CASE STUDY

A simple part (i.e. an elbow pipe) requiring 3 main processes, namely Casting, Spray Painting and Ultrasonic Inspection, is used to demonstrate the application of EPE modelling. The part is made from an aluminium alloy.

The TE for casting process has been calculated based on values for the latent heat of melting of the material (L), specific heat capacity of the material (C), temperature of the material (T), melting temperature of the material (T_m) and finally mass of the material (m), using the Equation $[mC(T_m - T) + mL]$. Similarly for Ultrasonic Inspection, the values for number of transmitters (N_{trans}), power of transmitter (P) and duration of transmission (T) were used to calculate the TE requirement, using the Equation $[N_{trans} * (PT)]$. Finally the TE for the Spray Painting together with AE for all three processes were measured empirically.

In this example, the IE requirements were different due to the specific nature of each process, therefore 3 manufacturing zones have been defined for this application. The attribution of IE for a single part in each zone was calculated based on the total IE consumption per hour divided by the throughput for each zone, which in this case were 12 parts per hour for the casting process, 20 parts per hour for spray painting and 30 parts per hour for the ultrasonic inspection process. It should be noted that in this case study, the times spent in each zone were inclusive of queuing (waiting) time, set-up time, part loading and unloading times, etc., and therefore these times were greater than the actual processing time of the part. It is argued that inclusion of such miscellaneous (non-productive) times provides a greater degree of accuracy in the attribution of Indirect Energy to a product and enables further analysis of productive versus non-productive energy consumption.

These calculations and the associated values for the TE, AE, IE and the total Embodied Product Energy for the case study product are summarised in Table 1 and illustrated in Figure 5.

Table 1: Equations for Calculating EPE for a Simple Elbow Pipe Fitting

Calculation of EPE for Product A			
Process 1: Casting	Process 2: Spray Painting	Process 3: Inspection	Total
$TE(1)_A = mC(T_m - T) + mL$ $= 0.5 * 0.46(1809.2 - 298.15) + 0.5 * 272$ $= 484 \text{ kJ}$ <i>m</i> : Mass (kg) <i>C</i> : Specific heat capacity (kJ/kg) <i>T_m</i> : Melting temperature (K) <i>T</i> : Temperature of metal before melting (K) <i>L</i> : Latent heat of melting (kJ/kg)	$TE(2)_A$: determined empirically $= 168 \text{ kJ}$	$TE(3)_A = N_{trans} * P * T$ $= 8 * 0.5 * 2$ $= 4 \text{ W} * 2$ $= 0.24 \text{ kJ/min} * 2$ $= 0.48 \text{ kJ}$ <i>N_{trans}</i> : Number of transmitters <i>P</i> : Power of transmitter (W) <i>T</i> : duration of use (mins)	ΣTE_A 652 kJ
$AE(1)_A$: Vacuum + Process Inefficiencies $= 100 + 50$ $= 150 \text{ kJ}$	$AE(2)_A$: Pump + Process Inefficiencies $= 125 + 60$ $= 197 \text{ kJ}$	$AE(3)_A$: Conveyor System $= 101 \text{ kJ}$	ΣAE_A 448 kJ
$IE(1)_A = IE_{zone1} / (60 / T_{zone(1)_A})$ $= 2000 / (60 / 5)$ $= 167 \text{ kJ}$ <i>IE_{zone1}</i> : Average IE consumed in the zone per hour (kJ/hr) <i>T_{zone1}</i> : Time part spends in zone 1 (mins)	$IE(2)_A = IE_{zone2} / (60 / T_{zone(2)_A})$ $= 1800 / (60 / 3)$ $= 60 \text{ kJ}$ <i>IE_{zone2}</i> : Average IE consumed in the zone per hour (kJ/hr) <i>T_{zone2}</i> : Time part spends in zone 2 (mins)	$IE(3)_A = IE_{zone3} / (60 / T_{zone(3)_A})$ $= 1000 / (60 / 2)$ $= 33 \text{ kJ}$ <i>IE_{zone3}</i> : Average IE consumed in the zone per hour (kJ/hr) <i>T_{zone3}</i> : Time part spends in zone 3 (mins)	ΣIE_A 260 kJ
$EPE(1)_A = 800 \text{ kJ}$	$EPE(2)_A = 425 \text{ kJ}$	$EPE(3)_A = 135 \text{ kJ}$	$\Sigma EPE_A =$ 1360 kJ

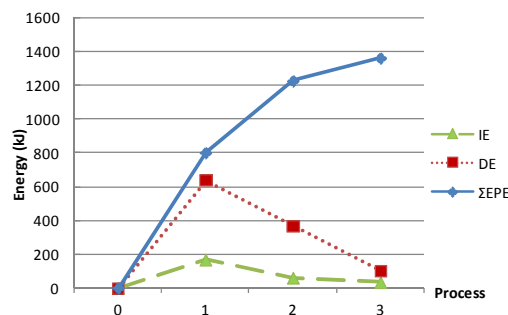

Figure 5: Breakdown of Energy Consumption for the Manufacture of Case Study Product

In this case study, the TE clearly consumes the greatest proportion of total energy at 48%, followed by the AE at 33%, and in fact the IE contributes the least to the total EPE (19%). Furthermore, the values of $ER_{process}$, $ER_{product}$, and $ER_{production}$ are all relatively very high (i.e. 0.59, 0.48, and 0.80 respectively), representing efficient processes, product, and production system. Clearly, the EPE modelling framework not only provides an overview on how much energy is required to manufacture a unit product, but also enables further investigation of various factors that play a major influence on the energy consumption within a production system. Therefore, it is argued that such energy simulation models can be used as

effective decision tools to minimise the energy used during the operations and to support the implementation of ‘Energy Efficient Manufacturing’.

In addition to supporting operational decisions, the EPE framework could also provide energy transparency right back to the design process, enabling designers to select the most energy efficient materials and processes whilst fulfilling the requirements in the product specification, as depicted in Figure 6. Such a “Design for Energy Minimisation” approach will potentially enable businesses to go beyond the incremental improvements achievable via existing energy management systems, and to consider energy efficiency and utilisation across both the design and manufacturing phases of a product life-cycle.

5 CONCLUDING DISCUSSIONS

The existing commercial energy management tools provide a high level overview of energy consumption within a manufacturing system, hence are unable to model the detailed breakdown of energy flows among various processes, workstations and production zones. More importantly, they cannot determine the specific energy attribution for the manufacture of a unit product. The recent rise in the energy cost together with the increasing number of legislative and social requirements highlight the importance of adopting an ‘Energy Efficient Manufacturing’ approach in future manufacturing applications.

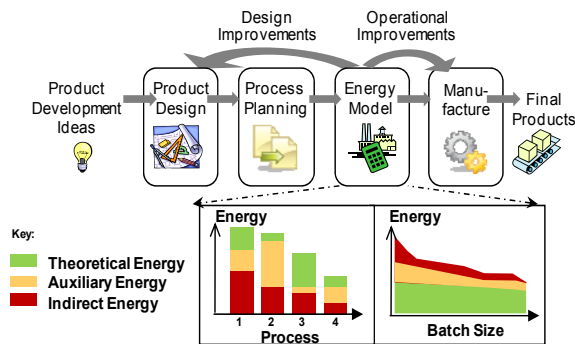

Figure 6: Utilisation of Energy Simulation Model to Support both Design and Operational Decisions

To support such approach, the energy consumption in manufacturing facilities can be reduced by either using more efficient technologies and/or equipment to improve production processes, and also through more efficient monitoring and control of energy used in infrastructure and technical services to optimise the ‘plant’ level activities. The major research assertion made is that step change improvements in the productivity of energy consumption within manufacturing (and remanufacturing [12]) applications can only be effectively achieved through integration of these global factory level and local process level energy considerations through a novel framework based on a product viewpoint. The Embodied Product

Energy framework and the associated energy simulation tools not only enable a reactive approach to minimise energy consumption through improved operational decisions but also support a proactive approach to improve product design by eliminating non-productive energy intensive processes. Finally, it is claimed that significant reduction in energy consumption within manufacturing applications can only be gained through such proactive “Design for Energy Minimisation” approach.

5 REFERENCES

- [1] International Energy Agency, 2008, World Energy Outlook 2008, Available at: <http://www.worldenergyoutlook.org/2008.asp> [Accessed 15 September 2009]
- [2] World Resources Institute, 2005, World Greenhouse Gas Emissions: 2005, Available at: <http://www.wri.org/chart/world-greenhouse-gas-emissions-2005> [Accessed 10 August 2009]
- [3] Jovane, F., Yoshikawa, H., Alting, L., Boër, C. R., Westkamper, E., Williams, D., Tseng, M., Seliger, G. and Paci, A. M., 2008, The incoming global technological and industrial revolution towards competitive sustainable manufacturing, *CIRP Annals - Manufacturing Technology*, **57**, 641-659.
- [4] International Energy Agency, 2009, World Energy Outlook 2009, Available at: http://www.iea.org/country/graphs/weo_2009/fig1-1.jpg
- [5] Andreassi, L., Ciminelli, M. V., Feola, M. and Ubertini, S., 2009, Innovative method for energy management: Modelling and optimal operation of energy systems, *International Journal of Energy and Buildings*, **41**, 436-444.
- [6] Mills, E., Shamshoian, G., Blazek, M., Naughton, P., Seese, R. S., Tschudi, W. and Sartor, D., 2008, The business case for energy management in high-tech industries, *Energy Efficiency Journal*, **1**, 5-20.
- [7] Devoldere, T., Dewulf, W., Deprez, W., Willems, B., Duflou, R.J. 2007, Improvement Potentials for Energy Consumption in Discrete Part Production Machines. Proceedings of the 14th CIRP Conference on Life Cycle Engineering, Tokyo, Japan. 311-316.
- [8] Gutowski, T., J. Dahmus, et al., 2006, Electrical Energy Requirements for a Manufacturing Process. Proceedings of 13th CIRP International Conference on Life Cycle Engineering, Leuven, Belgium, 623-627
- [9] Herrmann, C. and Thiede, S., 2009, Process chain simulation to foster energy efficiency in manufacturing, *CIRP Journal of Manufacturing Science and Technology*, **1**, 221-229.
- [10] Hauschild, M., Jeswiet, J. and Alting, L., 2005, From Life Cycle Assessment to Sustainable Production: Status and Perspectives, *CIRP Annals - Manufacturing Technology*, **54**, 1-21.
- [11] Ghosh, S., Chattopadhyay, A. B. and Paul, S., 2008, Modelling of specific energy requirement during high-efficiency deep grinding, *International Journal of Machine Tools and Manufacture*, **48**, 1242-1253.
- [12] Sutherland, J. W., Adler, D. P., Haapala, K. R. and Kumar, V., 2008, A comparison of manufacturing and remanufacturing energy intensities with application to diesel engine production, *CIRP Annals - Manufacturing Technology*, **57**, 5-8.