



New insights into scale-up processing and C–S bond formation reactions

**Thesis submitted for the Degree of Doctor of Philosophy at
Cardiff University**

Vincenzo Fusillo

January 2012

DECLARATION

This work has not previously been accepted in substance for any degree and is not concurrently submitted in candidature for any degree.

Signed (Vincenzo Fusillo) Date

STATEMENT 1

This thesis is being submitted in partial fulfillment of the requirements for the degree of(insert MCh, MD, MPhil, PhD etc, as appropriate)

Signed (Vincenzo Fusillo) Date

STATEMENT 2

This thesis is the result of my own independent work/investigation, except where otherwise stated.

Other sources are acknowledged by explicit references.

Signed (Vincenzo Fusillo) Date

STATEMENT 3

I hereby give consent for my thesis, if accepted, to be available for photocopying and for inter-library loan, and for the title and summary to be made available to outside organisations.

Signed (Vincenzo Fusillo) Date

Acknowledgements

I'd like to thank my supervisor Dr. Mark C. Bagley for his support throughout my PhD and for his enthusiasm for chemistry that is contagious and inspiring. Another thank you goes to Prof. Nick Tomkinson and to Prof. David Knight for helpful suggestion and encouragement.

All my colleagues in the group and in the group of Nick Tomkinson shared with me the good and bad moments we had in and outside the lab: Caz, Ellie, Matt, Krishna, Paola, Morgane, Beth, Gabriele, Mohammed, Joel and Tim, Paul, Deb, Kerri, Antonio, Kevin, Jacki, Achim, John, Sylvain, Mike...our lab wouldn't have been an enjoyable place if it weren't for you guys...thanks.

A special thanks goes to Cardiff University staff: Rob Jenkins, Robin, Dave, Gaz, Jamie, Sham and Matt...thanks for your support and for the lessons of welsh culture...cheerio!

I met so many people in Cardiff that made this experience unique and unrepeatable. Among them: Lino, Grazia, Manu, Vane, Caterina, Frenchie, Niek, Veronica, Anabelle, Maurizio, Massimo, Damien, Angelo, Carmen are really worthy of being mentioned for the privilege I had of their friendship...thanks to you all.

A big "grazie" goes to my family: mum&dad, my brothers and grandma for their love and support in this experience of mine.

Abstract

This thesis describes the development of a new microwave-mediated methodology for C–S bond formation and the issues regarding scaling up heterocyclic transformations.

Chapter 1 provides an overview on the current understanding of microwave-mediated synthesis and on the use of microwave technology in copper- and palladium-mediated synthesis. A separate part is dedicated to the current advancements in the use of flow reactors within the chemical community.

Chapter 2 describes the application of the current batch and continuous flow technology for the scale-up of selected heterocyclic transformations, starting with the well known Bohlmann-Rahtz pyridine synthesis and moving to other reactions, including pyrimidine and Hantzsch dihydropyridine synthesis.

Chapter 3 describes the development of a new methodology for the microwave-mediated C–S bond formation, starting from an investigation on the current available methods and moving to the application of new methodology to the synthesis of a library of compounds. Further application was found in the synthesis of a drug candidate with anti-ageing properties and in the synthesis of a new class of anti-HIV compounds.

Abbreviations

Several abbreviations have been used throughout this thesis that may not be familiar to the reader. These abbreviations are listed below:

App	Apparent
APCI	Atmospheric pressure chemical ionisation
aq.	Aqueous
Ar	Aromatic
BINAP	2,2'-bis(diphenylphosphino)-1,1'-binaphthyl
Bn	Benzyl
Boc	<i>tert</i> -Butoxycarbonyl
b.p.	Boiling point
br	broad
Bu	Butyl
CI	Chemical ionisation
d	Day(s)
d	doublet
dd	doublet of doublets
Da	Dalton(s)
dba	Dibenzylideneacetone
DBU	1,8-diaza- bicyclo[5.4.0]undec-7-ene
DIBAL	Diisobutylaluminium hydride
DMA	Dimethylacetamide
DMAP	4-Dimethylaminopyridine
DMF	Dimethylformamide
dmphen	2,9-dimethyl 1,10-phenanthroline
DMSO	Dimethylsulfoxide

DPPF	1,1'-Bis(diphenylphosphino)ferrocene
EDC	1-ethyl-3-(3-dimethylaminopropyl) carbodiimide
EI	Electron ionisation
equiv.	Equivalent(s)
ES	Electrospray
Et	Ethyl
h	Hour(s)
HOBt	Hydroxybenzotriazole
HRMS	High resolution mass spectroscopy
Hz	Hertz
IBX	2-Iodoxybenzoic acid
IR	Infra-red
<i>J</i>	Coupling constant
L	Ligand
lit.	Literature
<i>m</i>	<i>meta</i>
m	Multiplet
M	Molar
MAOS	Microwave assisted organic chemistry
<i>m</i> CPBA	<i>meta</i> -Chloroperbenzoic acid
Me	Methyl
min.	Minute(s)
mmol	Millimole(s)
mp	Melting point
MS	Mass spectrometry
<i>n</i>	<i>normal</i>
NMP	<i>N</i> -Methylpyrrolidone
NMR	Nuclear magnetic resonance

NRTI	Nucleoside reverse transcriptase inhibitor
NNRTI	Non- nucleoside reverse transcriptase inhibitor
<i>o</i>	<i>ortho</i>
<i>p</i>	<i>para</i>
Ph	Phenyl
ppm	Parts per million
q	Quartet
quin	Quintet
r.t.	Room temperature
RT	Reverse transcriptase
s	Singlet
SET	Single electron transfer
SM	Starting material
SPPS	Solution phase peptide synthesis
t	Triplet
TBAB	Tetra <i>n</i> -butylammonium bromide
TBAF	Tetra <i>n</i> -butylammonium fluoride
THF	Tetrahydrofuran
TLC	Thin layer chromatography
TMS	Trimethylsilyl
UHP	Urea-hydrogen peroxide
WS	Werner Syndrome
μmol	Micromole(s)
μW	Microwave

CONTENTS

Declaration.....	i
Acknowledgements	ii
Abstract.....	iii
Abbreviations	iv
Chapter 1: Introduction.....	1
1.1 Microwave Theory	2
1.1.1 Introduction	2
1.1.2 Current Understanding	3
1.1.3 Future Perspective	7
1.2 Use of Microwaves in Cu- and Pd-mediated Synthesis	7
1.2.1 Introduction	7
1.2.2 Microwave-mediated Palladium Catalysis	8
1.2.3 Microwave-mediated Copper Catalysis.....	21
1.2.4 Microwave-mediated Copper and Palladium Simultaneous Catalysis.....	29
1.2.5 Conclusions	30
1.3 Flow Reactors in Organic Synthesis.....	31
1.3.1 Introduction	31
1.3.2 Microreactor design.....	31
1.3.3 Commercial devices	34
1.3.4 Applications in chemical synthesis	34
1.3.5 Conclusions	51
Chapter 2: Heterocycle synthesis under microwave irradiation.....	52
2.1 Goals of This Study	53
2.1.1 A model reaction for the synthesis of pyridines.....	53
2.1.2 Comparing Different Platforms for the Bohlmann-Rahtz Cyclodehydration Reaction.....	55
2.1.3 Conclusions	66
2.2 Synthesis of pyrimidines	67
2.2.1 Introduction	67
2.2.2 Results and Discussion	68
2.2.3 Conclusions	71
2.3 Hantzsch Dihydropyridine Synthesis	72
2.3.1 Introduction	72

2.3.2 Results and discussion	74
2.3.3 Conclusions	77
2.4 Application to natural product synthesis – attempted synthesis of Meridianins	77
2.4.1 Introduction	77
2.4.3 Conclusions	81
Chapter 3: A new microwave mediated Ullmann-condensation and its application to the synthesis of drug candidates of pharmaceutical relevance	82
3.1 Metal mediated C-S bond formation under MW irradiation	83
3.1.1 Introduction	83
3.1.2 Goal of this study	86
3.1.3 Reviewing Available Methods for C–S Bond Formation	86
3.1.4 Conclusions	102
3.2 Rapid Ullmann type C–S bond formation using Cu(I) catalyst and ligand	103
3.2.1 Introduction	103
3.2.2 Results and Discussion	103
3.2.3 Conclusions	113
3.3 Application in the synthesis of VX 745	114
3.3.1 Introduction	114
3.3.2 Results and Discussion	117
3.3.3 Conclusions	124
3.4 Application in the synthesis of anti-HIV compounds	124
3.4.1 Introduction	124
3.4.2 Results and Discussion	126
3.4.3 Conclusions	130
3.5 Application to C–F bond formation	130
3.5.1 Introduction	130
3.5.2 Results and Discussion	133
3.5.3 Conclusions	135
4. Summary and Conclusions	136
5. Experimental	138
5.1 Experimental techniques	138
5.2 General experimental procedures	139
5.3 Experimental procedures	141
References	183

Chapter 1: Introduction

1.1 Microwave Theory

1.1.1 Introduction

Microwave irradiation has received increasing interest in recent years as an alternative heating method in synthetic chemistry. The prospect of drastically reduced reaction times, enhancements in selectivity, improvements in yield and cleaner chemistries are some of the advantages that have attracted the attention of the chemical community, resulting in an exponential increase of papers since its first publication in organic synthesis in 1986 (Figure 1).¹

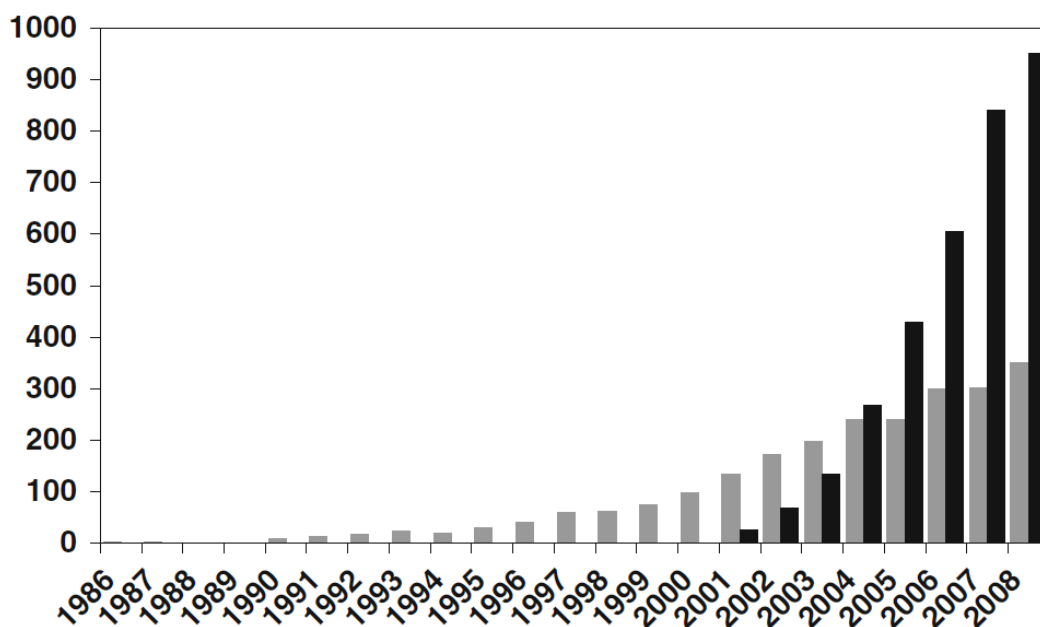

Figure 1. Publications on microwave-assisted organic synthesis (MAOS) (1986-2008). Gray bars: Number of articles involving MAOS for seven selected synthetic organic chemistry journals (*J. Org. Chem.*, *Org. Lett.*, *Tetrahedron*, *Tetrahedron Lett.*, *Synth. Commun.*, *Synthesis*, *Synlett*. SciFinder Scholar keyword search on “microwave”). The black bars represent the number of publications (2001-2008) reporting MAOS experiments in dedicated reactors with adequate process control (about 50 journals, full text search: microwave). Only those articles dealing with synthetic organic chemistry were selected.^{1a}

Winning over the initial scepticism, due mainly to the unsafe nature and irreproducibility of experiments in domestic microwave ovens, microwave chemistry has become a reliable and efficient heating method used by academic researchers and has found wide applicability in the

pharmaceutical industry. Nowadays, microwave energy has been extensively used in all chemical fields and the debate whether the advantages of using microwave irradiation to heat chemical reactions were due to thermal/kinetic effects or so-called “specific” microwave effects has come to a general agreement in favour of the thermal/kinetic effects.

1.1.2 Current Understanding

Dramatic rate accelerations and yield enhancements resulting from microwave irradiation often cannot be achieved by conventional heating but are still attributed to thermal effects. They are due to the specific mechanism of microwave heating, superheating and the selective absorption of a heterogeneous catalyst or reagents in a less polar medium that can generate the so-called “hot spots”. This is a thermal effect caused by the inhomogeneous field, resulting in high temperature zones within the sample. Hot spots may be created by the difference in dielectric properties of material in the sample, by the uneven distribution of electromagnetic field strength, or by volumetric dielectric heating under microwave conditions.

A representative reaction coordinate shows that the reagents must reach the higher energy level of the transition state (absorbing the energy required from the surrounding environment) to be converted into the reaction products (Figure 2).

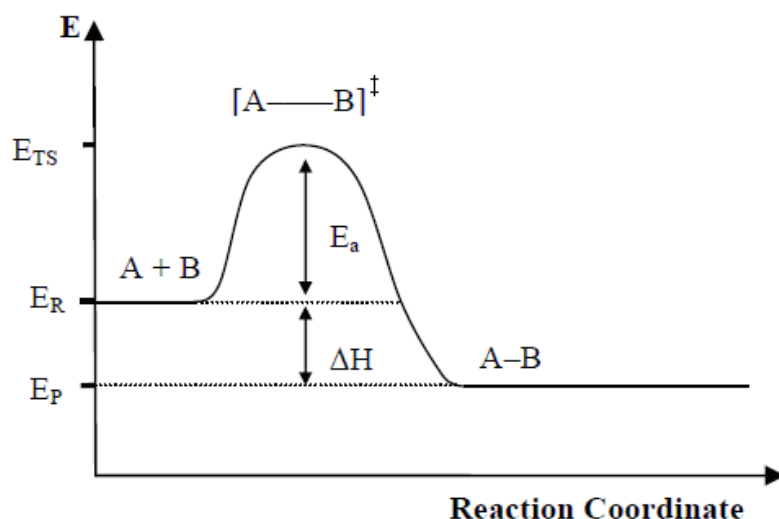

Figure 2. Typical reaction coordination for the transformation of the reagents A and B into the product A-B going through the transition state $[A-B]^\ddagger$

The speed associated to a transformation is given by the Arrhenius equation

$$k = Ae^{-E_a/RT}$$

where k is the reaction rate constant, A is the frequency of collisions with a correct geometry for a reaction to occur, E_a is the activation energy, R is the gas constant and T is the temperature. The exponential term represents the fraction of molecules with the minimum energy required to overcome the activation energy barrier. Based on the Arrhenius equation, Mingos and Baghurst calculated the rate acceleration due to an increase in temperature for a first order reaction. A rise in temperature from 77 °C to 177 °C results in a 1000-fold rate increase (13.4 h vs. 23.4 s).³ This suggests that many of the rate enhancements observed under microwave-assisted conditions can be rationalized by thermal/kinetic effects and they can be associated with specific thermal microwave effects.

However, the existence of non-thermal microwave effects has been proposed to be responsible for the rate acceleration, and in particular cases, altered product distributions observed in microwave-assisted reactions. Non-thermal microwave effects are defined as acceleration in reaction rate that cannot be rationalized by thermal, kinetic or specific effects. They have been proposed to result from a direct interaction of the electromagnetic field with specific molecules or intermediates in the reaction mixture (orientation effects) or from changes in thermodynamic parameters such as the activation energy or the Arrhenius pre-exponential factor A (due to an increase in the molecular mobility caused by the microwave field).

On this aspect, an interesting paper was published in 2009 by Leadbeater group on the use of *in situ* Raman spectroscopy for the investigation of specific microwave effects.⁴ No localized superheating was reported as the conversion of electromagnetic energy into kinetic energy was reported to be slower than the conversion of kinetic energy into thermal energy. These results were in contrast to previous speculations that heating reactions under microwave irradiation resulted in a higher population of energetically excited molecules.⁵ Other results in support of Leadbeater's findings are reported by Kappe and coworkers, using silicon carbide reaction vials to perform microwave chemistry.⁶

Silicon carbide (SiC) is well known for its properties of high thermal conductivity coupled with low thermal expansion and high strength, resulting in exceptional thermal shock resistant qualities. By the use of silicon carbide vials, Kappe demonstrated that it was possible to

separate thermal from non-thermal microwave effects by elimination of electromagnetic field effects on the reaction mixture (Figure 3).

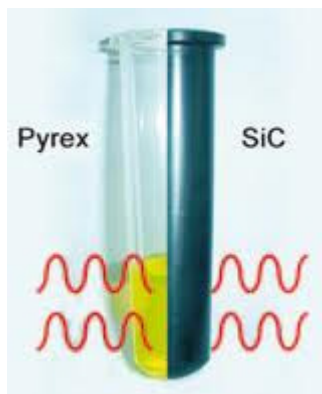
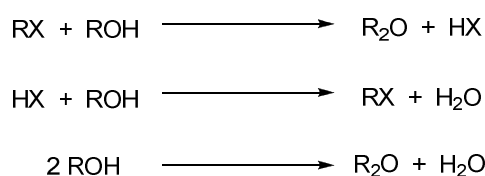

Figure 3. Silicon carbide blocks microwave heating⁷

Comparing reactions conducted in microwave-heated Pyrex vials showed that similar results in terms of conversion, product yields and purity were obtained, hereby suggesting that for the selected reactions there was no indication of specific microwave effects. A review from Strauss, describing scaling up issues of organic reactions using closed vessel microwave instrumentation, also reported on the most recent findings in the non-thermal microwave vs. specific microwave effects debate.⁸ Use of closed vessel reactors, microwave batch or continuous flow reactors was reported and compared for the scale-up from batch to flow reactors, discussing temperature measurement issues within the instrumentation.

Another review by Strauss in 2009 provided some examples of recent applications of microwaves to organic chemistry: Williamson etherification as a high temperature process (Scheme 1), Fischer-Helferich glycosylation as an example of kinetic vs. thermodynamic product formation (Scheme 2), solvent-free Jacobs-Gould reaction for the synthesis of quinolone antibacterial agents (Scheme 3) and some examples of reactions at high temperature using water as solvent (Fisher indole synthesis and decarboxylation, Scheme 4).⁹



Scheme 1. Symmetrical etherification

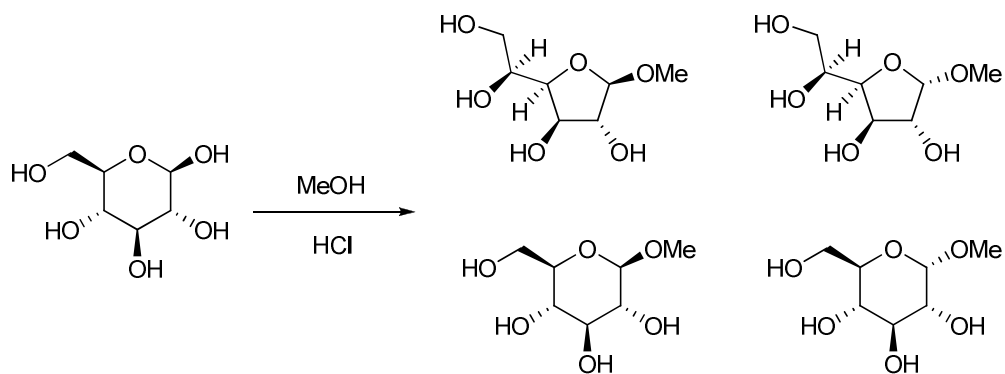

Scheme 2. Fisher-Helferich glycosylation of D-glucose with methanol: formation of four possible methyl glycoside isomers is possible

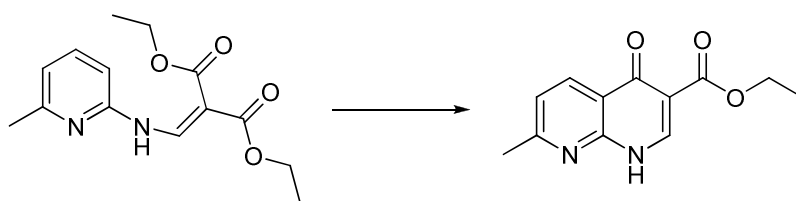

Scheme 3. An example of solvent-free Jacobs-Gould reaction

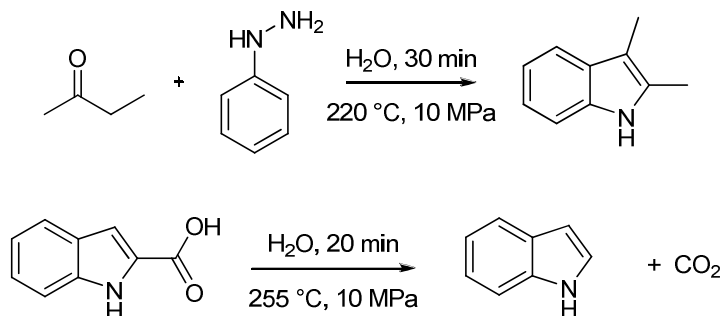

Scheme 4. Fisher indole synthesis and decarboxylation, both in water

Different examples of microwave heating applied to radical chemistry, metathesis reactions, natural product synthesis, metal-mediated transformations, organocatalysis and multi-component reactions were reported in an exhaustive report from Caddick in 2009.¹⁰ From this review, the examples of linear peptide synthesis that could lead to efficient large-scale synthetic proteins in a day are remarkable.¹¹ Very recently a book on microwave applications in the proteomics field has been published, illustrating the different aspects of the use of microwave heating in chemical or acid digestion of proteins and their post-translational modifications¹² and gives an account of a number of microwave-assisted proteomic protocols currently in use in biochemical studies.

Recently, there have been many detailed descriptions of microwave theory, of the equipment nowadays available on the market, the processing techniques currently used and many experimental protocols highlighted to carry out chemical transformations under microwave heating.¹ In 2009, a follow up of the Kappe review of 2004 was published,¹³ with highlights from the 2004-2008 literature.¹⁴ Just in this short period, more than 220 examples are discussed, with almost 930 references cited to cover all the aspects of microwave applications in chemical synthesis.

1.1.3 Future Perspective

Microwave technology has nowadays seen extensive use in the synthetic community and industry at large, but incorporation of this platform in academic laboratories is still poor, due to the cost of the microwave instrumentation and to the reluctance of chemists towards changes in technology. Advances are expected in many fields including the biosciences and in chemical scale-up to large scale production. On this last point, technical developments in chemical engineering are likely to be pursued in future years to address these issues, with major obstacles being the cost of microwave energy per installed kilowatt and the inefficiency in converting electricity to microwave energy.

1.2 Use of Microwaves in Cu- and Pd-mediated Synthesis

1.2.1 Introduction

Palladium and copper are nowadays extensively used in various aspects of chemical synthesis. Palladium is one of the most versatile and useful metals in organic synthesis.¹⁵ Its ability to form stable complexes, its low toxicity, its toleration of a wide variety of functional groups, and low sensitivity to air and moisture, not to mention the recent drop in its price, makes it one of the preferred metals of choice to mediate organic reactions on small and industrial scale. Virtually any field of organic chemistry has been influenced by the utility of palladium-catalyzed processes, including C–C¹⁶ to C–N^{15e}, or C–O^{15e} bond formation, even C–P¹⁷ or C–F¹⁸ bond formation, C–H activation,¹⁹ heterocyclic synthesis,^{15f} carbonylation and

decarboxylation reactions, and so forth. On the other hand, copper²⁰ is another very popular metal for the organic chemist. In recent years, there has been a renewed interest towards copper-mediated processes, mainly due to the introduction of “click chemistry”, a concept presented by Sharpless in 2001,²¹ based on previous work from Huisgen in the 1960s.²² Copper does possess some distinct advantages over palladium: while palladium oxidation states are defined to three (namely 0, 2 and 4), copper could have access to odd oxidation states (1 and 3), apart from the “normal” ones (0 and 2). Because of this, copper can take part in one electron (or radical) transfer processes. Since the introduction of microwave synthesis in the late 80’s, the scientific community has been overwhelmed by the contribution of this powerful platform to the advance of synthetic capability. The scope of this part of the introduction will be to describe how microwave irradiation could affect metal-mediated processes, sometimes in unique and unexpected ways.

1.2.2 Microwave-mediated Palladium Catalysis

One application of microwave irradiation to palladium-catalyzed transformations is described in the work on H/D exchange carried out by the Derdau group in 2009.²³ The preparation of isotopically labelled internal standards is nowadays extensively required for investigation of samples *via* tandem mass spectrometry in combination with liquid chromatography (LC-MS/MS). A new safe method that used NaBD₄-activated palladium (or rhodium) catalyst and D₂O as deuterium source was developed, that avoided use of gaseous reagents, promoted by the use of microwave irradiation or automated high-throughput devices. Initial studies were conducted on 2-aminobenzoic acid (Scheme 5): 1 equivalent of **1** was reacted in D₂O in presence of 10 mol% of catalyst and 5 mol% of NaBD₄ at 150 °C for 2 hours under microwave irradiation. Incorporation of deuterium was observed in a particularly efficient and specific way when the reaction was carried out under microwave irradiation (compared to the conventional heating), giving high rates of H/D exchange in all the positions (apart from the C6), as shown from the yields reported in brackets in Scheme 5. Further tests were conducted using *para*-substituted anilines and substituted pyridines, obtaining substantial deuterium incorporation in all cases.

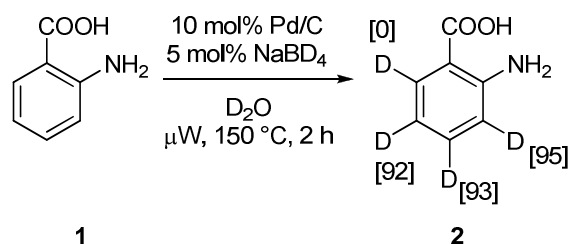

Scheme 5. H/D exchange studies using 2-aminobenzoic acid

The substitution of hydrogen for fluorine is another important process in organic chemistry to prepare fluorine containing compounds that could be used as pharmaceuticals or imaging agents. A new study from the Sanford group was released in 2006,²⁴ showing the first example of palladium-catalyzed C–H activation/C–F bond formation (Scheme 6). 8-Methylquinoline was chosen to conduct the initial investigation because of facile C–H bond activation. A set of fluorine sources was initially tested in presence of palladium acetate as catalyst, among which *N*-fluoro-2,4,6-trimethylpyridiniumtetrafluoroborate (**3a**) and *N*-fluoropyridinium tetrafluoroborate (**3b**) were chosen for their high reactivity. Microwave irradiation accelerated the process, allowing the reaction to be carried out in 1 hour at 110 °C instead of 18 hours with conventional heating at the same temperature.

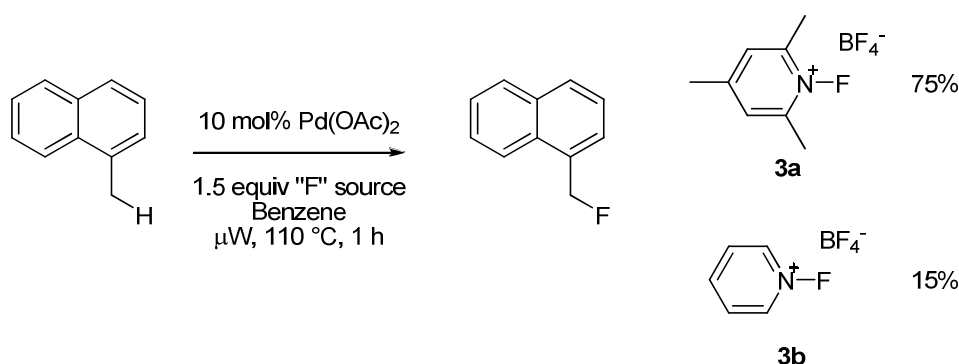

Scheme 6. C–F bond formation

These findings were applied to the C–H bond fluorination of a series of quinolines and pyridines, obtaining the desired compounds in very good yields.

Palladium complexes have also been used in the one-pot Sonogashira carbonylation-annulation reaction applied to the synthesis of substituted flavones, as shown in the work of Capretta in 2009 (Scheme 7).²⁵ Previous investigation within the Capretta group²⁶ on palladium-catalyzed coupling of aryl halides with terminal acetylenes opened the way to the application of this methodology in flavone synthesis that avoids the harsh reaction conditions (strong bases, acids or elevated temperature) reported in the literature. Investigation on catalyst, solvents, temperatures and bases was carried out for the carbonylation-annulation

reaction: the best conversion to product used 1 equivalent of aryl halide, 1.5 equivalents of acetylene, 1.5 mol% of Pd₂(dba)₃ and 3 mol% of 1,3,5,7-tetramethyl-2,4,8-trioxa-6-phenyl-6-phosphaadamantane (PA-Ph) in the presence of Cs₂CO₃ or DBU as base in DMF. These conditions were also ideal for the Sonogashira reaction (to generate the alkyne **4**), allowing the one-pot flavone synthesis in short time and very good yield. Even in this case, microwave irradiation accelerated the process, increasing the yields substantially.

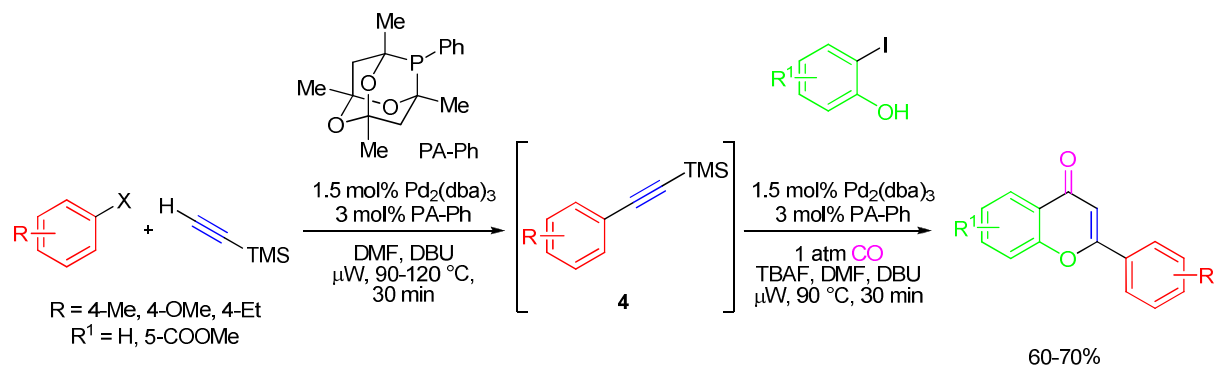

Scheme 7. Microwave-mediated synthesis of substituted flavones

An example of the Hiyama-coupling reaction enhanced with microwave irradiation was reported in 2008 by Nájera and coworkers (Scheme 8).²⁷ Usually, the Hiyama-coupling requires a fluoride anion to activate the organosilanes but recently use of inorganic bases as activators was reported in the literature.²⁸ The fluoride-free cross-coupling reaction of silanes with aromatic and vinyl halides was then performed in water using sodium hydroxide as activator under microwave heating for 10-20 minutes at 120 °C, obtaining the desired compound in excellent yields. Palladium acetate was the catalyst of choice, but palladacycle **5** was also used, both in small quantities (0.01-2 mol%).

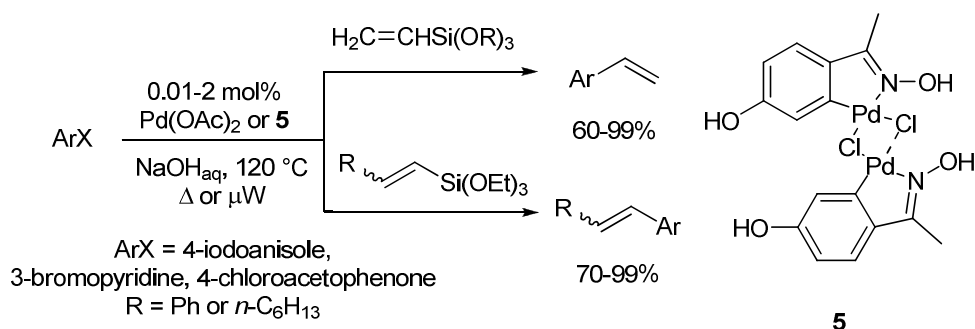

Scheme 8. Pd-catalyzed Hiyama-coupling

Water was the solvent of choice in an example of Suzuki-coupling under microwave irradiation with simultaneous cooling reported by the Leadbeater group in 2005 (Scheme 9).²⁹

Different substituents were used on the aryl chloride moiety, giving the corresponding biaryl product in excellent yield in a very short reaction time.

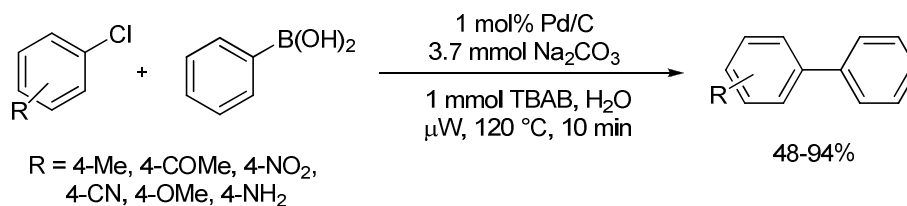

Scheme 9. Example of Suzuki-coupling in water

The first example of intramolecular Suzuki-Miyaura-coupling was the key step in the total synthesis of biphenomycin B (Scheme 10).³⁰ After optimization studies to select the best reaction conditions, it was found that a mixture of toluene/water gave better results than DMSO and acetonitrile, using tetrabutylammonium bromide (TBAB) as additive.

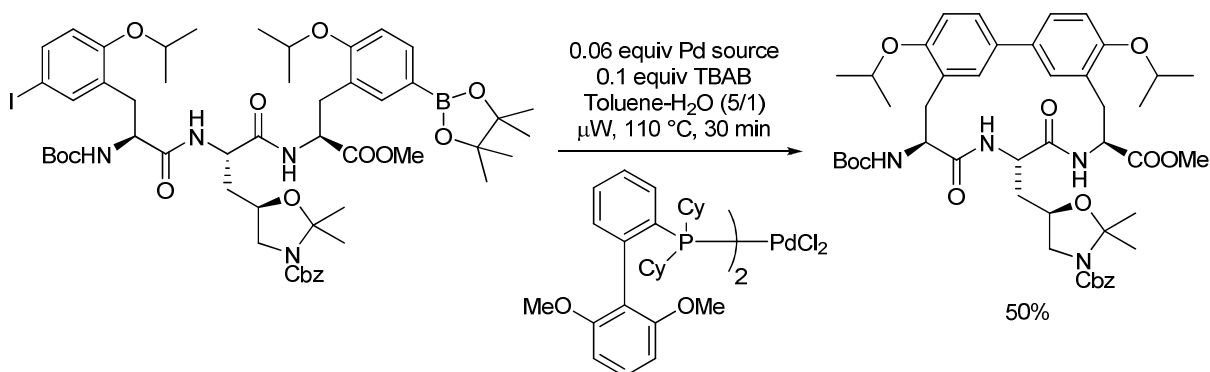

Scheme 10. Intramolecular Suzuki-Miyaura-coupling in toluene/water

Polyurea microencapsulated palladium catalyst has been widely applied to cross-coupling reactions and reductions, with evident advantages in terms of workup, reutilization of the catalyst and less metal contamination of the final products. In 2006, the Ley group reported the use of this type of catalyst in a microwave-assisted Suzuki reaction (Scheme 11).³¹ A library of biaryl compounds was generated with high yields and purities, controlling the temperature profile by simultaneous cooling of the vessel. This allowed the transfer of this type of methodology to large scale synthesis in flow reactors.

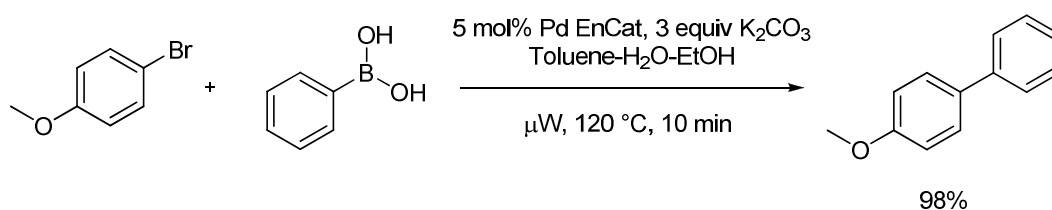

Scheme 11. Suzuki-coupling using microencapsulated Pd

Application of microwave heating proved particularly efficient in reducing the reaction times and improving the yields for the arylation of flavones, as shown by the Caddick group in 2006 (Scheme 12).³² The reaction of flavone bromides or triflates with selected boronic acids in presence of a mixture of palladium complexes **6** and caesium fluoride afforded the desired arylated flavones in excellent yields.

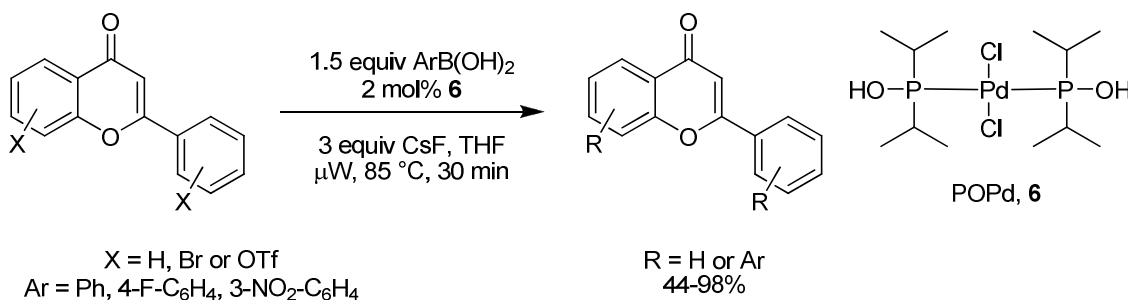

Scheme 12. Arylation of flavones under Pd catalysis

Functionalization of flavones was also carried out by Buchwald-Hartwig amination, as reported in the same paper (Scheme 13). In this case, a different catalyst/ligand combination was chosen to afford the aminated flavones in good to moderate yield.

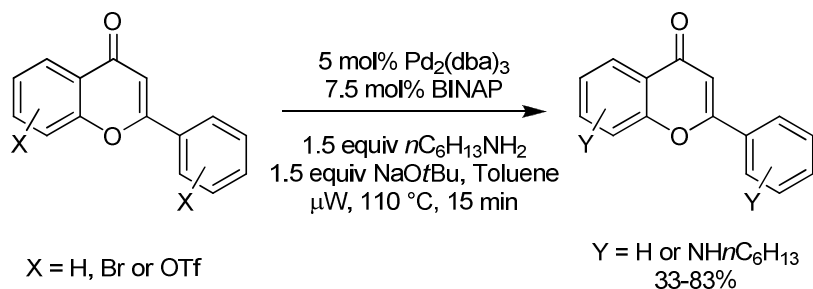

Scheme 13. Example of Buchwald-Hartwig amination on bromoflavones

The Nájera group reported in 2008 an application of the same palladacycle **5**, used for the Hiyama-coupling,²⁷ in the Molander modification of the Suzuki-Miyaura cross-coupling reaction (Scheme 14).³³ Potassium aryltrifluoroborates were cross-coupled with aryl and heteroaryl chlorides in water at reflux under phosphine free conditions, using microwave irradiation to reduce the reaction times from 4-20 hours to 15-20 minutes.

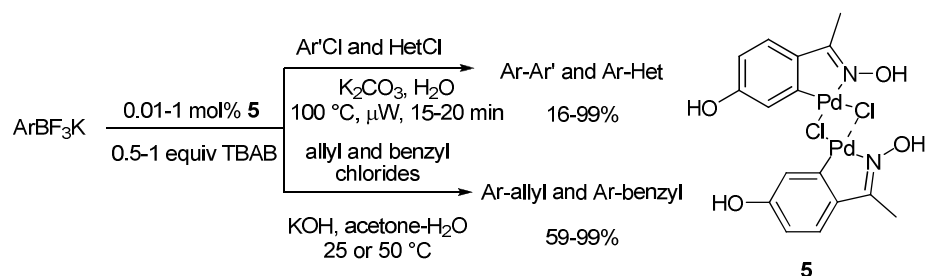

Scheme 14. Molander modification of Suzuki-Miyaura reaction

Another example of the Suzuki-Miyaura reaction was reported in the construction of phenanthrene derivatives, together with an aldol condensation.³⁴ A combination of palladium catalysis and microwave irradiation afforded highly functionalized phenanthrenes from aryl bromides and *o*-formyl or *o*-acetyl-arylboronic acids in a rapid and reliable way (Scheme 15).

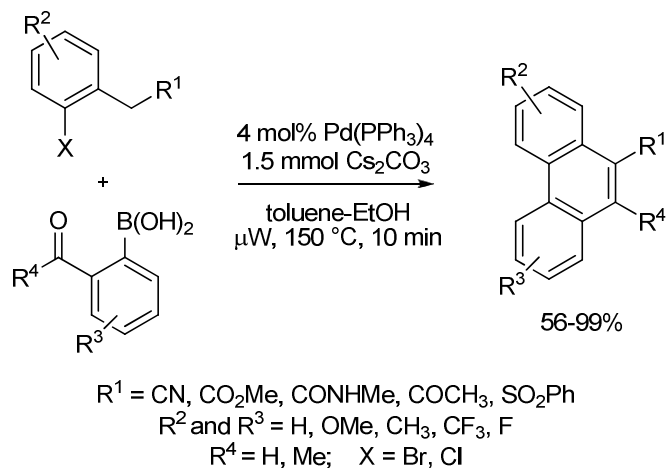

Scheme 15. Microwave-assisted phenanthrene synthesis

A different example of microwave-assisted Suzuki-Miyaura cross-coupling was applied to the synthesis of substituted pyridazinones by Cao's group in 2008 (Scheme 16).³⁵ Two different catalytic systems were tested: the optimum conditions used palladium/S-Phos as catalyst, 1,4-dioxane as solvent and potassium fluoride as base, allowing for functionalization of the pyridazinone scaffold.

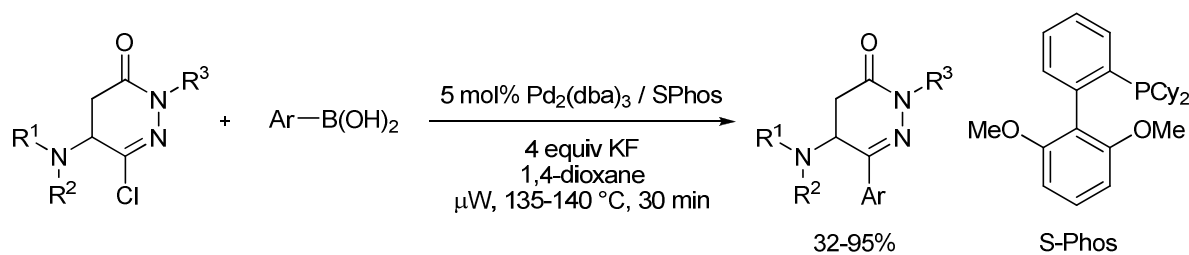

Scheme 16. Microwave-assisted pyridazinone synthesis

A new methodology for the synthesis of alkynyltrifluoroborates from the corresponding haloaryltrifluoroborates *via* initial Sonogashira-coupling followed by Suzuki-coupling was reported in 2010 (Scheme 17).³⁶ With this methodology, in the first reaction step there was no need to protect the boronic acids and the reaction could be performed at room temperature in relatively short reaction times. The following Suzuki reaction could be performed at 150 °C for 1 hour under microwave irradiation to afford the corresponding C–C coupled products in good yields.

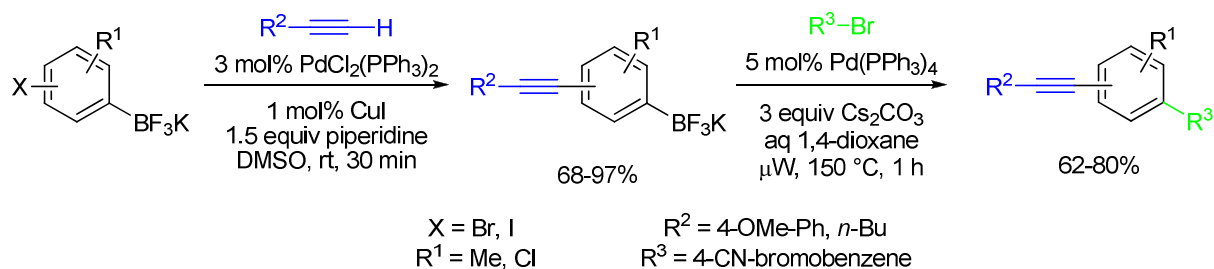

Scheme 17. Alkynyltrifluoroborate synthesis *via* Pd-catalyzed reactions

The Larhed group reported in 2007 an example of palladium(II)-catalyzed base-free oxidative Heck reaction conducted at room temperature or under microwave heating (Scheme 18).³⁷ Only a small amount of palladium acetate was required in conjunction with 2,9-dimethyl-1,10-phenanthroline (dmphen) as ligand and it was possible to scale-up the reaction with full conversion to product in only 20 minutes (compared to 24-240 hours with conventional heating).

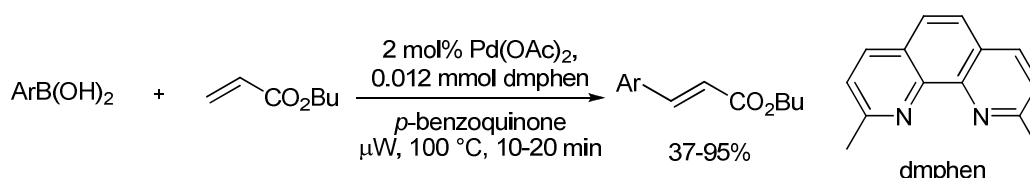

Scheme 18. Base-free oxidative Heck reaction

A different example of Heck-coupling among allylic esters and arenediazonium salts was reported in 2009 (Scheme 19).³⁸ The reaction had the advantage of total regio- and stereochemical control; it was ligand-free and was applied to the short total synthesis of natural kavalactones.

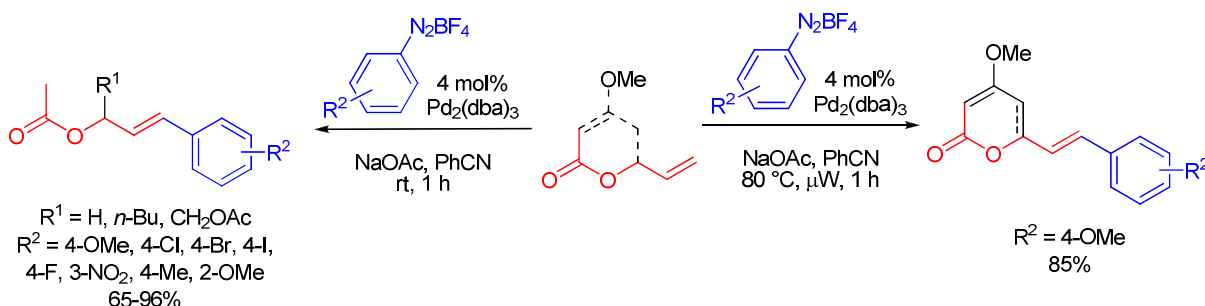

Scheme 19. Ligand-free Heck reaction

The Suzuki-Miyaura (Scheme 20) and Heck-coupling (Scheme 21) reactions have been tested in a capillary reactor system under microwave irradiation, as reported by Organ and co-workers.³⁹ It was shown that both the reactions under flow conditions gave the desired products in excellent yields, whereas the reaction conducted with conventional heating failed

to proceed. It was proposed that catalysis in these Pd-coated capillaries took place in solution, whereby the metal nanoclusters were liberated from the surface of the capillary during the course of the process.

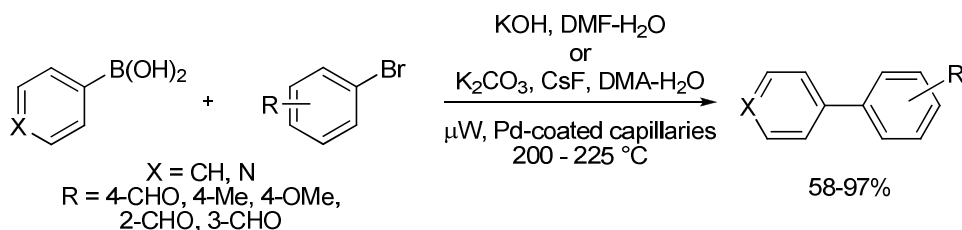

Scheme 20. Suzuki-Miyaura-coupling in Pd coated capillaries

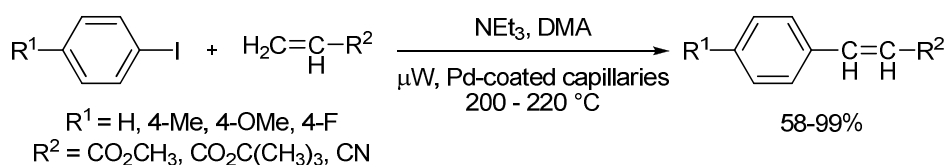

Scheme 21. Heck-coupling in Pd coated capillaries

Moving to C–P bond formation, a convenient and general method for the microwave-mediated synthesis of aryl and vinylphosphonates was recently reported in the literature (Scheme 22).⁴⁰ This class of compounds has received increasing interest for biological application and its accessibility widened when a palladium-catalyzed process was disclosed.⁴¹ Furthermore, microwave-mediated C–P bond formation had never been explored before this release. The Stawinski group reported the reaction of 1.1 equivalents of aryl or vinyl halides with a 0.25 M solution of phosphonate diester, in the presence of 5 mol% of Pd(PPh₃)₄ as catalyst and 1.2 equivalents of Cs₂CO₃, in THF at 120 °C for 10 minutes under microwave irradiation, obtaining the desired aryl or vinylphosphonates in very good yields.

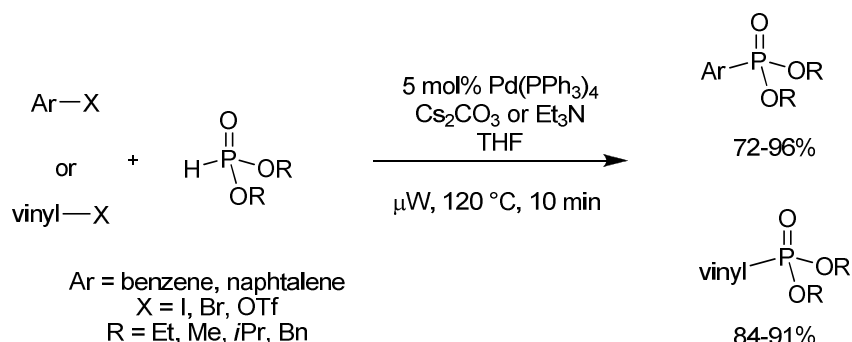

Scheme 22. Example of Pd-catalyzed C-P bond formation

Related to the previous work, the Larhed group reported several examples of Pd(II)-catalyzed P-arylation in the absence of base or acid (Scheme 23).⁴² Arylboronic acids and aryl

trifluoroborates were used as starting materials, together with diethylphosphite, palladium acetate and *p*-benzoquinone (as oxidant).

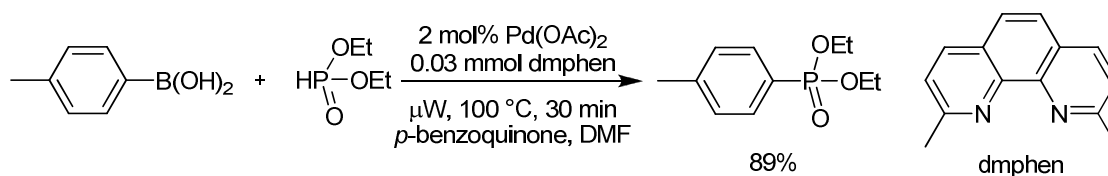

Scheme 23. Example of Pd-catalyzed P-arylation

Also from the Larhed group there was a recent example of microwave-mediated aminocarbonylation reported in water (Scheme 24).⁴³ Aryl bromides were rapidly converted to benzamides using molybdenum hexacarbonyl as a solid CO source and a palladium catalyst (**7**). Noteworthy is the fact that the aminocarbonylation reaction was dominant over any competitive hydroxycarbonylation.

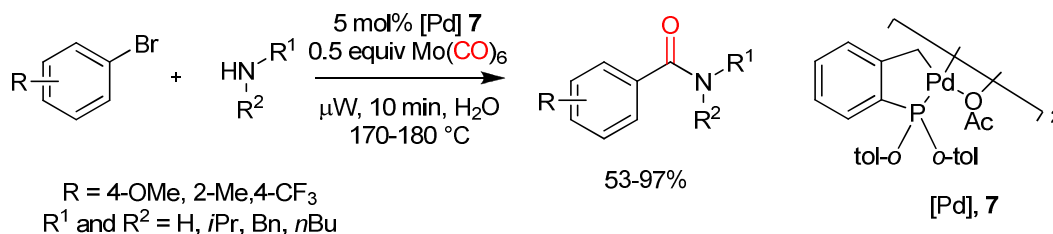

Scheme 24. Aminocarbonylation example from Larhed group

In a similar fashion, aryl and heteroaryl acyl sulfamides were synthesized *via* metal-catalyzed carbonylation, as reported by Roberts at AstraZeneca R&D (Scheme 25).⁴⁴ In this case, gaseous carbon monoxide was used instead of a CO solid source. It was interesting to note that aryl bromides reacted more efficiently than aryl iodides in the test reactions and were the starting materials of choice in the vast majority of the cases.

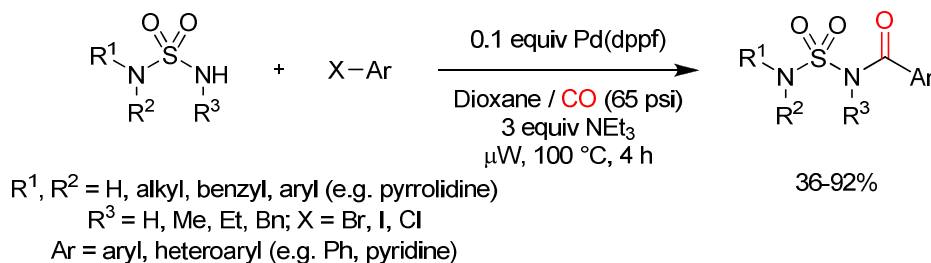

Scheme 25. Acyl sulfamides synthesis *via* Pd-catalyzed carbonylation

The synthesis of a similar class of compounds *via* palladium-catalyzed *N*-arylation of sulfonamides with aryl chlorides was reported in 2003 by GSK scientists (Scheme 26).⁴⁵ The possibility of carrying out the reaction with aryl chlorides, usually unreactive precursors, and

using sulfonamides as nitrogen nucleophiles in a fast microwave-mediated fashion made this methodology very interesting for application in parallel library synthesis.

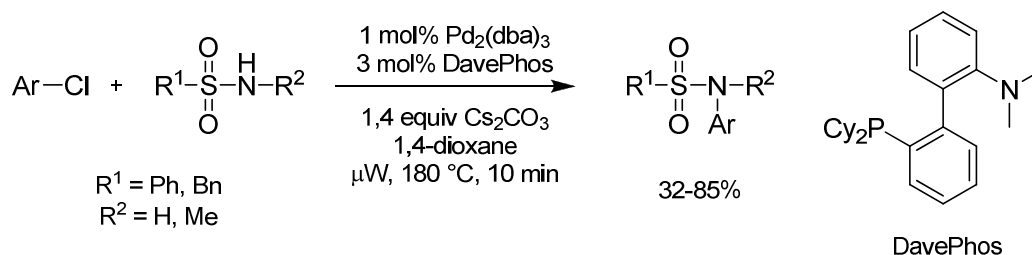

Scheme 26. Example of *N*-arylation of sulfonamides

A similar example of a C–N bond coupling reaction was reported in the same year by a different group (Scheme 27).⁴⁶ The preparation of 1-aminonaphthalenes and 5- and 8-aminoquinolines from the respective aryl bromides by palladium-catalyzed aryl amination was described under microwave irradiation with very short reaction times and good to excellent yields.

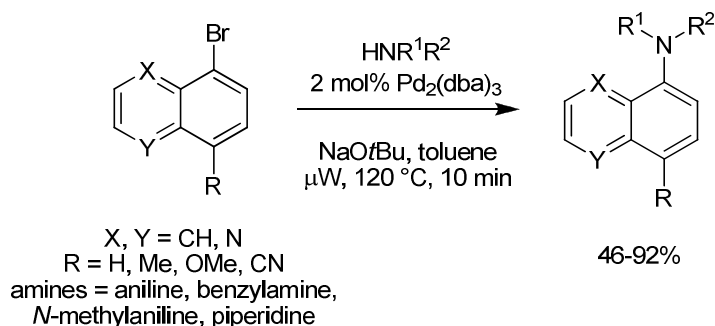

Scheme 27. Aryl amination synthesis *via* Pd-catalyzed reaction

Very recently in the literature an example of decarboxylative benzylation of substituted imines was reported by Chruma and coworkers (Scheme 28).⁴⁷ Heteroaryl imines and various esters were tolerated, allowing the formation of a new Csp³–Csp³ bond by use of a simple catalyst/ligand combination.

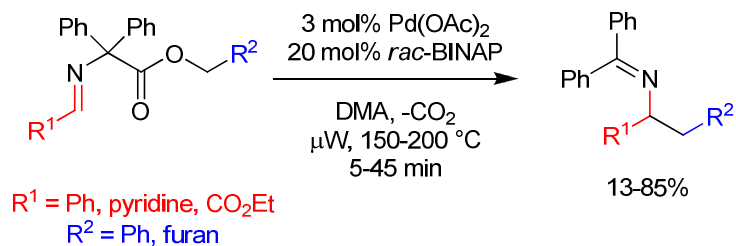

Scheme 28. Example of decarboxylative benzylation of imines

Palladium catalysis under microwave irradiation was also applied to the preparation of carbo- and heterocycles *via* intramolecular cyclization, as shown by Lautens in 2005 (Scheme 29).⁴⁸ Preparation of five- to seven-membered carbo- and oxygen- or nitrogen-containing heterocycles was successful in a very short time by microwave irradiation *via* Pd(II)-catalyzed reaction between an allyl moiety and aryl iodides. The same reaction carried out under conventional heating provided the desired product, but always in lower yield.

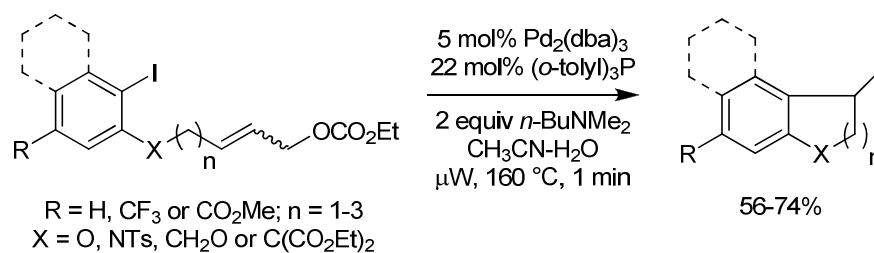

Scheme 29. Preparation of carbo- and heterocycles via Pd catalysis

A different report from the Lautens group in 2007 showed an example of a palladium-catalyzed C–H functionalization for the synthesis of highly substituted aromatic nitriles (Scheme 30).⁴⁹ *Ortho*-alkylation (or arylation) of aryl iodides or bromides was carried out using alkyl (or aryl) chlorides, followed by a cyanation reaction.

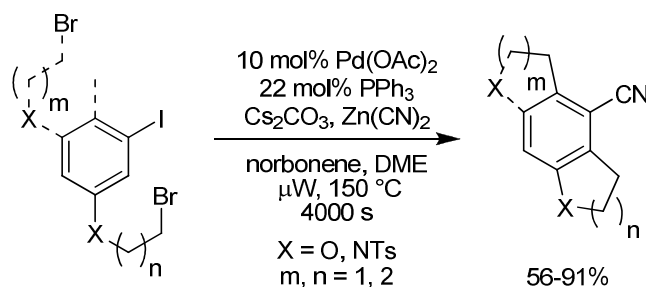

Scheme 30. C–H functionalization in the synthesis of aromatic nitriles

In one of the reports from the Nolan group, the catalytic activity of palladacycle complex **8** was explored and applied to different reactions (Scheme 31).⁵⁰ Among them, the α -ketone arylation of aryl chlorides with ketones was tested under microwave irradiation, providing excellent conversion rates in 2 minutes time (compared to one hour reaction with conventional heating).

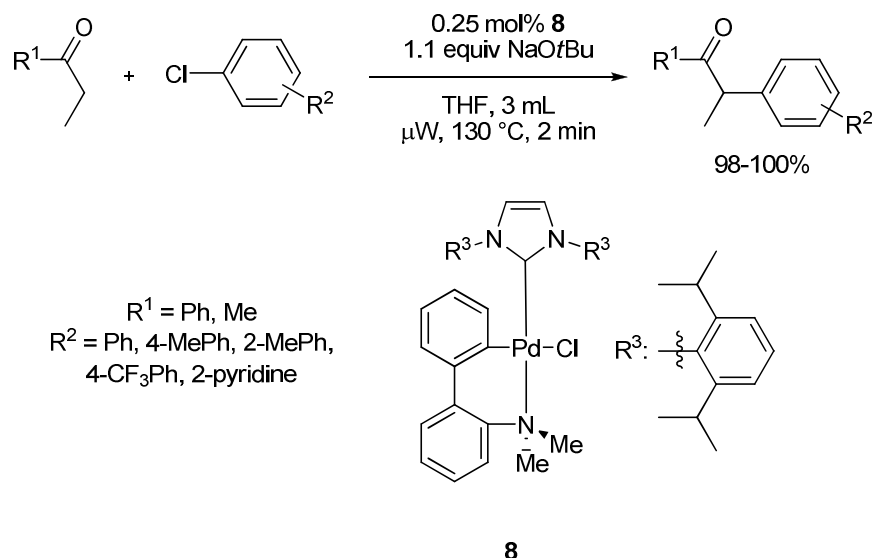

Scheme 31. α -Arylation of ketones as reported by the Nolan group

Related to the previous work, a ligand-free palladium-catalyzed reaction for the α -arylation of benzyl ketones was reported in 2009 by the Leadbeater group (Scheme 32).⁵¹ The reactions were performed under phase-transfer conditions in a mixture of water-sodium hydroxide-tetrabutylammonium bromide, using 0.1 mol% of palladium acetate as catalyst, avoiding use of phosphines or carbenes as ligands. The high stabilization of the carbanion in the intermediate state by the two phenyl groups was a key to the success of this reaction.

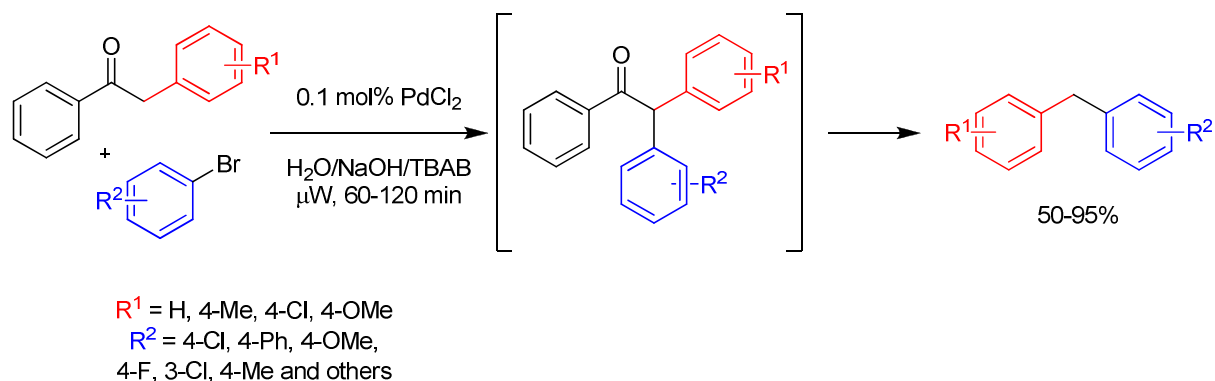

Scheme 32. Preparation of diarylmethanes by α -arylation of benzyl ketones as reported by the Leadbeater group

A number of methods for metal-catalyzed decoration of substituted dihydropyrimidones (DHPMs) under microwave irradiation were reported by the Larhed group in collaboration with Kappe.⁵²

Because of its interesting pharmacological activities, the dihydropyrimidinone was chosen as scaffold to explore a series of transformations, starting with C–C coupling reactions (Scheme

33). Heck and Suzuki reactions were performed on substrate **9** under microwave irradiation, giving the desired coupling products in moderate yields in relatively short time.

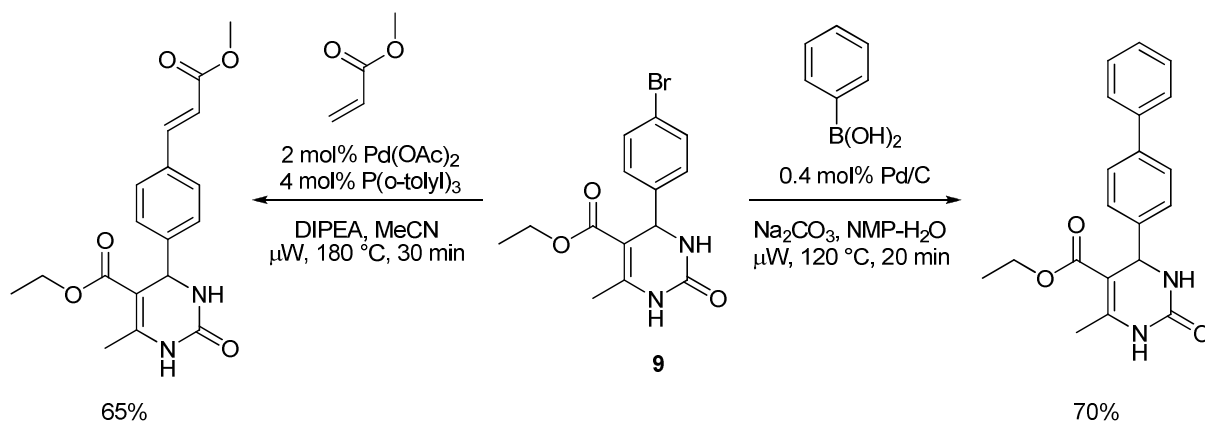

Scheme 33. Heck and Suzuki reaction examples

Examples of aminocarbonylation were also explored according to previous literature conditions.⁵³ Molybdenum hexacarbonyl was used as a solid CO source, using the Herrmann palladacycle ($[\text{Pd}_2(\text{OAc})_2(\text{P}(o\text{-tolyl})_3)_2]$) and Fu salt (**10**) to carry out preparative reactions. The desired amides were obtained in good to excellent yields in only 15 minutes. Alkoxy carbonylations were also performed using lower temperatures (110 °C) and switching to methanol (instead of THF), obtaining the esters in good yields. On the other hand, an example of Goldberg reaction was successfully performed, avoiding the harsh conditions that this reaction usually required: *N*-amidation of **11** was conducted with palladium acetate/XantPhos in THF at 120 °C in 15 minutes using microwave heating (Scheme 34).

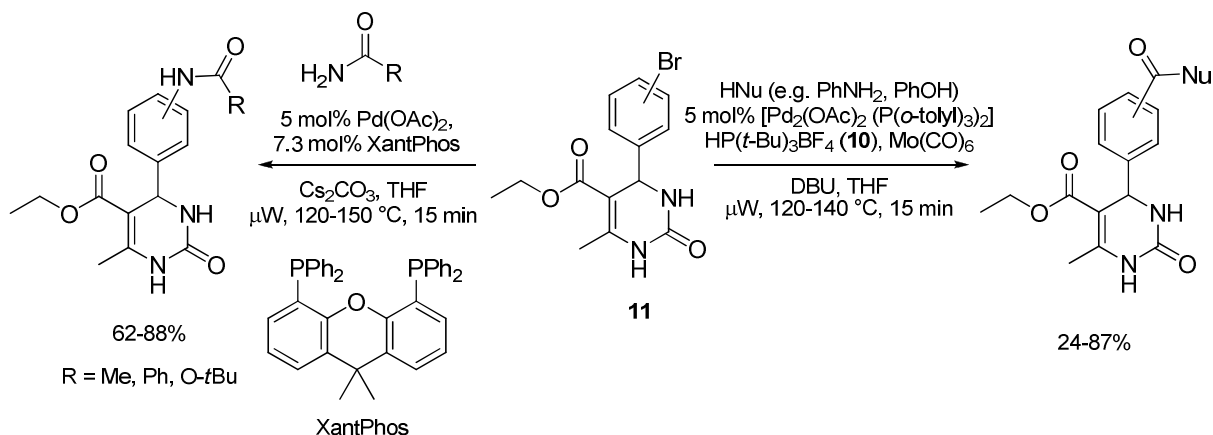

Scheme 34. Aminocarbonylation/alkoxy carbonylation and amidation examples

To finish, the first example of *N*-3 arylation of DHPM intermediates **12** was reported using simple reaction conditions: copper(I) iodide was the catalyst of choice with Cs_2CO_3 as base in

DMF at 180 °C for 40 minutes (Scheme 35). No product was obtained when aryl bromides or chlorides were used as starting materials.

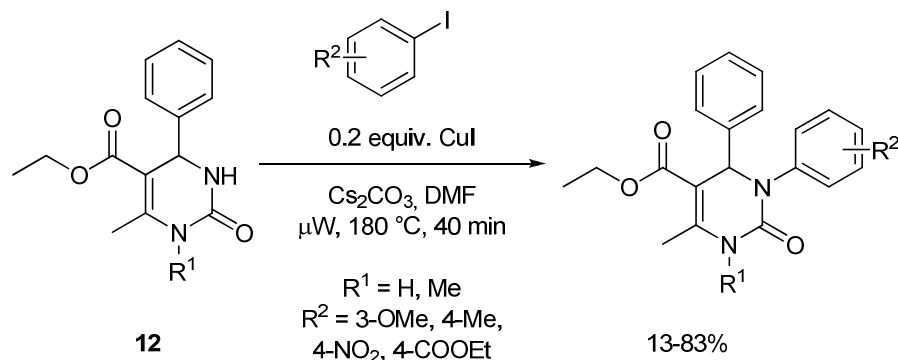

Scheme 35. Example of *N*-3 arylation of DHPM intermediates

1.2.3 Microwave-mediated Copper Catalysis

A new route to pyridine synthesis was recently reported by Moody and coworkers, that required metal carbene *N*-H insertion, 1,2,4 triazine formation and Diels-Alder reaction (Scheme 36).⁵⁴ The conversion of hydrazines to 1,2,4-triazines proceeded *via* Cu(II) catalysis in dichloromethane using methyl 2-diazo-3-oxobutanoate as diazocarbonyl component. The reaction was conducted under microwave irradiation for 10 minutes at 80 °C, followed by treatment with ammonium acetate in acetic acid to give the triazines. A Diels-Alder reaction was the next step to give the pyridine as final product. This was the first example of hydrazines being used as *N*-H compounds involved in carbene *N*-H insertion.

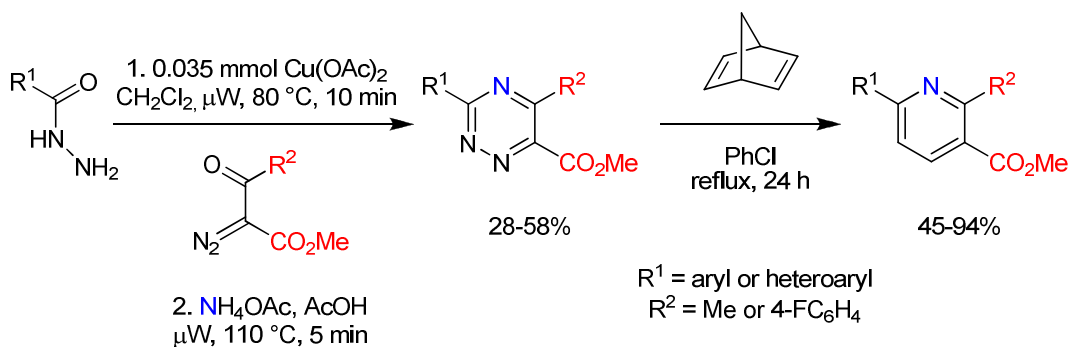

Scheme 36. Example of pyridine synthesis *via* Cu(II) catalysis

An example of microwave-controlled click chemistry for the preparation of tetrazoles was reported in 2007 by the Vilarrasa group (Scheme 37).⁵⁵ Taking into consideration the safety risks connected with the use of azides and cyanides, an investigation into the role of solvent

and catalyst was conducted to find the mildest conditions to carry out the reaction. Copper(I) triflate (0.1 mmol) was the catalyst of choice in dichloromethane at 80 °C for 2 h. Microwave irradiation was used to attenuate temperature and pressure safely. The main product of the reaction was the 1,5-regioisomer **13a**, known to be the only product under thermal activation but minor fractions of the 1,4-regioisomer **13b** were also obtained under the selected conditions. These side products were removed by column chromatography. This methodology was applied to the synthesis of an AZT analogue used in anti-HIV therapy.

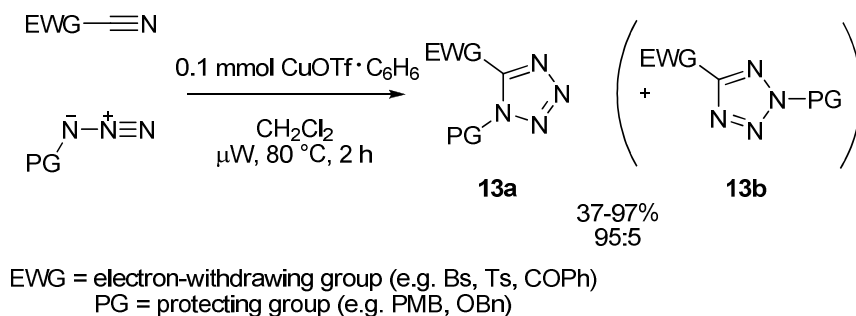

Scheme 37. Preparation of tetrazoles from nitriles and organic azides

Also by click chemistry, a new tris-triazole copper complex (**14**) was prepared, as reported in 2009 by Pericàs (Scheme 38).⁵⁶

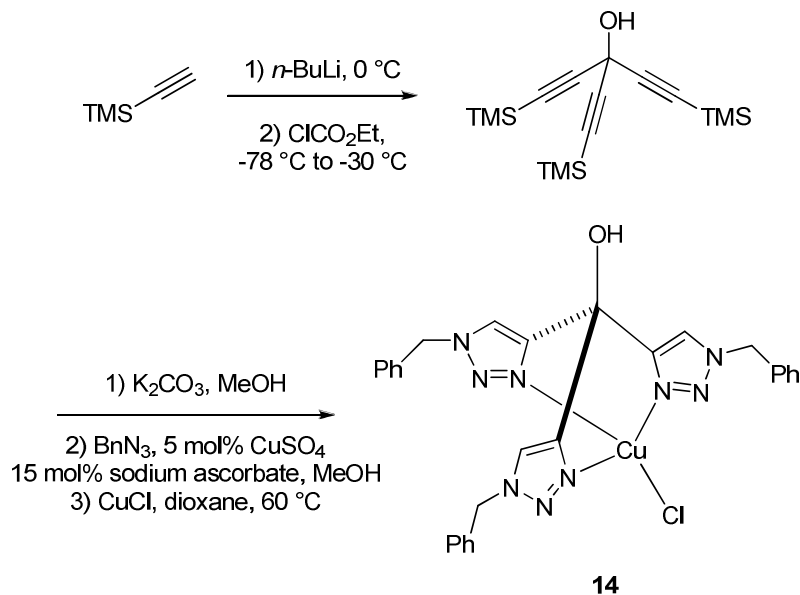

Scheme 38. Preparation of the tris-triazole ligand **14**

This complex was then used as catalyst to perform Cu(I) catalyzed alkyne-azide cycloaddition in water as solvent, obtaining a range of substituted 1,4 triazoles in reaction times no longer than 40 minutes (Scheme 39).

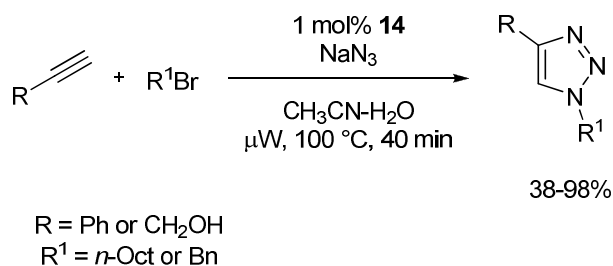

Scheme 39. One-pot 1,4-triazoles formation

In 2006 the first example of heterogeneous copper-catalyzed click chemistry appeared in the literature from the Lipshutz group.⁵⁷ The reaction between aliphatic or aromatic alkynes and azides mediated by copper on charcoal was performed in minutes at 150 °C using microwave heating (Scheme 40). This methodology showed several advantages: there was no need for an external ligand or a base to enhance the reactivity (even if stoichiometric triethylamine accelerated the reaction), there was a large choice of compatible solvents, sterically hindered substrates were tolerated and the presence of air did not affect the activity of the catalyst.

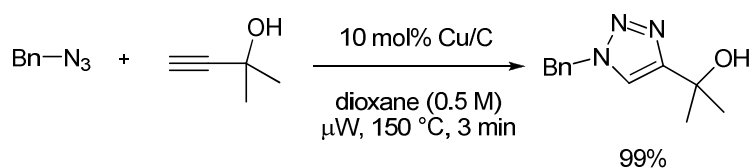

Scheme 40. First example of heterogeneous Cu/C-catalyzed click chemistry

In 2010 a new example of heterogeneous copper-catalyzed chemistry appeared in the literature (Scheme 41). Polymeric dinuclear alkynylcopper(I) complexes **16** were prepared and used as heterogeneous catalysts for copper-catalyzed azide-alkyne cycloaddition (CuAAC) reactions, as reported by Heaney and coworkers.⁵⁸ In the typical reaction of benzylazide with an excess of phenylacetylene in the presence of copper(II) hydroxyacetate, the triazole **17** was formed in very good yield, with simultaneous presence of the diyne product **15** (in a 10:1 ratio) and phenylethynylcopper(I) **16**. The catalyst, **16**, which was generated during the process, could be recovered at the end of the reaction and reused.

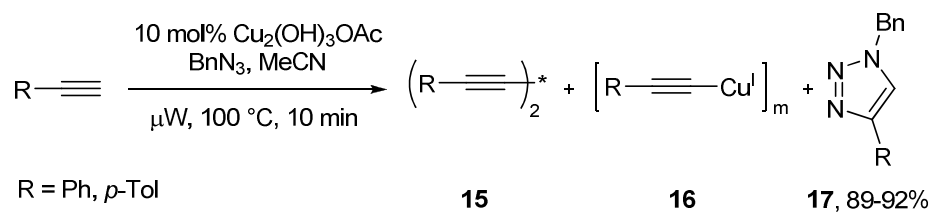

Scheme 41. Use of polymeric dinuclear Cu(I) complexes in CuAAC reactions

Microwave heating has been combined with other technologies. In 2009 a study from the Brimble group demonstrated that it was possible to combine SPPS and microwave synthesis in the reaction of an azide-functionalized aminoacid with an alkynylated sugar to generate neoglycopeptides precursors.⁵⁹ Synthesis of the building block **18** was performed at 80 °C in less than 5 minutes under copper(II) catalysis in an aqueous medium (H₂O/*t*-BuOH) (Scheme 42). These neoglycopeptides were believed to have antifreeze activity.

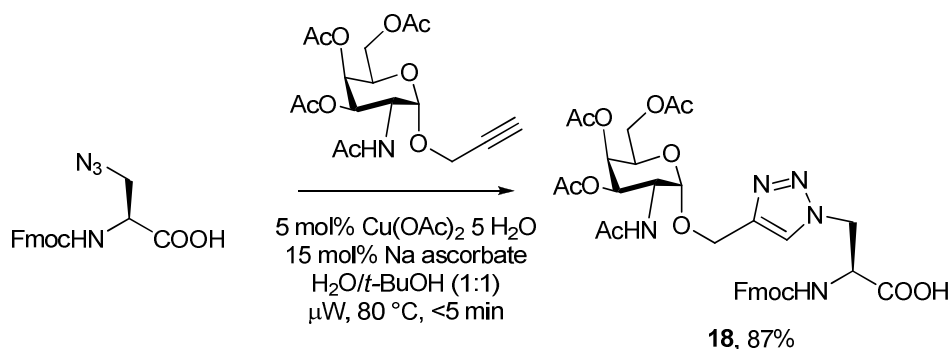

Scheme 42. Synthesis of the neoglycosyl aminoacid building block **18**

Interestingly, functionalization of a triazole scaffold at the *N*-2 position is also possible by microwave irradiation, as shown by Shi in 2008 (Scheme 43).⁶⁰ Arylation of 4,5-disubstituted triazoles was carried out regioselectively under copper(I) catalysis in presence of proline as ligand and potassium carbonate as base in dimethylsulfoxide, shortening the reaction times to 30 minutes using microwaves. This class of compounds was found to have photonic luminescent properties.

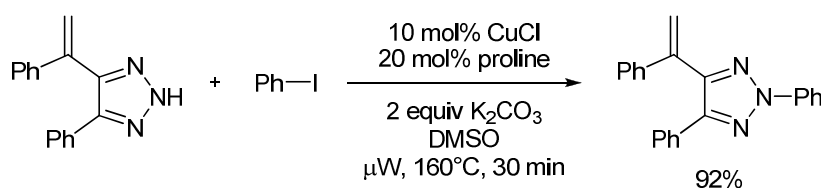

Scheme 43. Cu(I)Cl-mediated *N*-2 triazole arylation

An example of Daugulis copper-catalyzed arylation⁶¹ was reported for the synthesis of an important class of pharmacophores such as benzodiazepines and benzotriazepines (Scheme 44).⁶² Catalyst loading and temperature, as well as copper source, phenyl halide partner, base and solvent were analyzed to find the optimum reaction conditions. Benzotriazepines were successfully coupled with both electron-poor and electron-rich aryl iodides under copper(I) catalysis using lithium *tert*-butoxide in DMF at 140 °C for 12 h under conventional heating. The reaction was then performed under microwave irradiation, obtaining almost total conversion to product in just 1 h in the presence of 1 equiv of Cu(I) iodide.

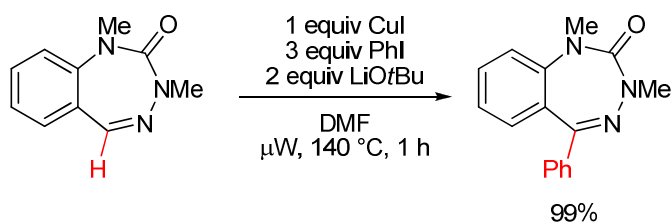

Scheme 44. Example of microwave-mediated arylation of benzotriazepines

Two different approaches for the synthesis of benzoxazoles *via* domino annulation reactions under microwave irradiation were reported in 2008 by Batey and co-workers (Scheme 45).⁶³ In the first, there was initial formation of the C–N bond of the oxazole by copper-catalyzed coupling of the amide, followed by intramolecular C–O bond formation to close the ring (*pathway a*). In the second pathway, initially there was an acylation of 2-bromoanilines with acyl chlorides, followed by intramolecular copper-catalyzed C–O bond formation (*pathway b*). The second methodology was found to be better than the first, due to the limited commercial availability of 1,2-dihaloarenes and regioselectivity problems associated with dihalide functionalization. A library of benzoxazoles was generated using the conditions reported in Scheme 46.

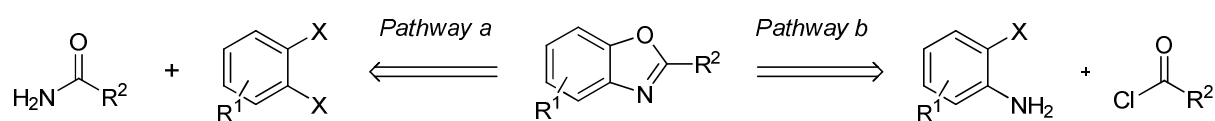

Scheme 45. Different methodologies for the synthesis of substituted benzoxazoles

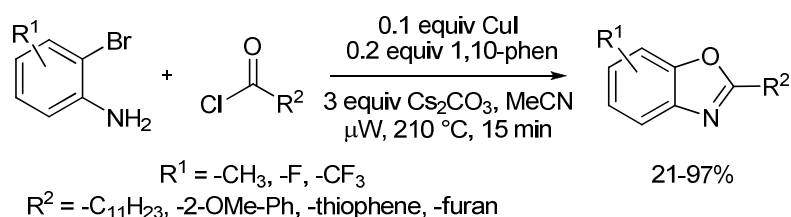

Scheme 46. Benzoxazole formation *via* intramolecular C–O bond formation

An example of C–N bond formation using water as solvent was reported in 2007 by Larhed and coworkers.⁶⁴ Various aminoacids were *N*-arylated successfully under copper(I)-catalyzed microwave-assisted conditions, such as L-phenylalanine with less than 6% racemisation (Scheme 47). It was possible to couple and simultaneously deprotect a set of amino acid esters to give the free acid as product. Moreover, from the detection of a copper-aminoacid complex by mass analysis, aminoacids were proven to have a role as metal ligands. This study then found application in the synthesis of angiotensin receptor ligand peptidomimetics.

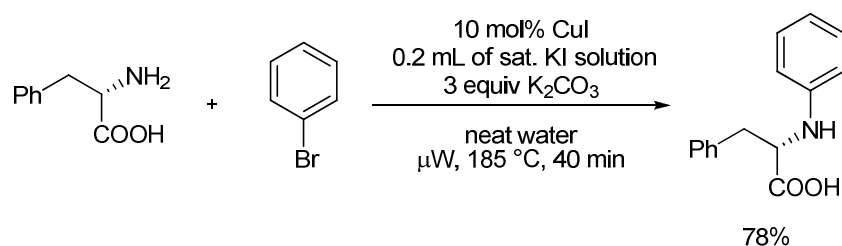

Scheme 47. Water as solvent in the Cu(I)-catalyzed arylation of L-phenylalanine

Another example of C–N bond formation under ligand-free conditions was reported in 2010 by Liu and coworkers (Scheme 48).⁶⁵ Iron/copper co-catalyzed cross-coupling reaction of aryl halides with amines was carried out for 30 minutes at 150 °C under microwave irradiation to afford the corresponding coupling products in moderate to good yields. This protocol showed a broad substrate scope and did not require anhydrous solvents or inert atmosphere.

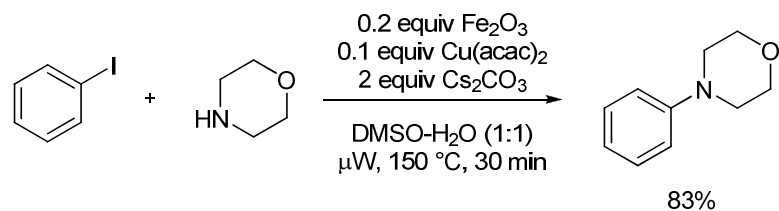

Scheme 48. Example of ligand-free *N*-arylation of aryl halides with amines

Another example of a bimetallic catalytic system was recently developed by Lipshutz and found various applications in different organic reactions (Scheme 49).⁶⁶ Lipshutz reported the preparation of copper and nickel on charcoal and its use in the Suzuki-Miyaura-coupling of aryl bromides and chlorides with aryl boronic acids. Reaction for 1 hour under microwave irradiation gave the expected product in comparable yields to the monometallic nickel on charcoal reactions.⁶⁷ Another reaction to which this system was applied was C–N bond formation between aryl halides and primary or secondary alkyl- or arylamines: the desired secondary or tertiary amines were obtained in just 1 hour at 200 °C *via* microwave heating. With this catalytic system it was also possible to conduct dehalogenation reactions in the presence of a mild hydride source but substrates containing ketones could not be used because of the competitive reactions that could take place. Click chemistry reactions could also be performed with this bimetallic catalyst, providing triethylamine was added to the reaction medium, at 60 °C in a time range of 10–20 minutes to 3 hours. Finally, C–O bond formation with activated and deactivated aryl bromides was carried out at 200 °C under microwave irradiation in the presence of phenanthroline as ligand and caesium carbonate as base to give the corresponding aryl ethers.

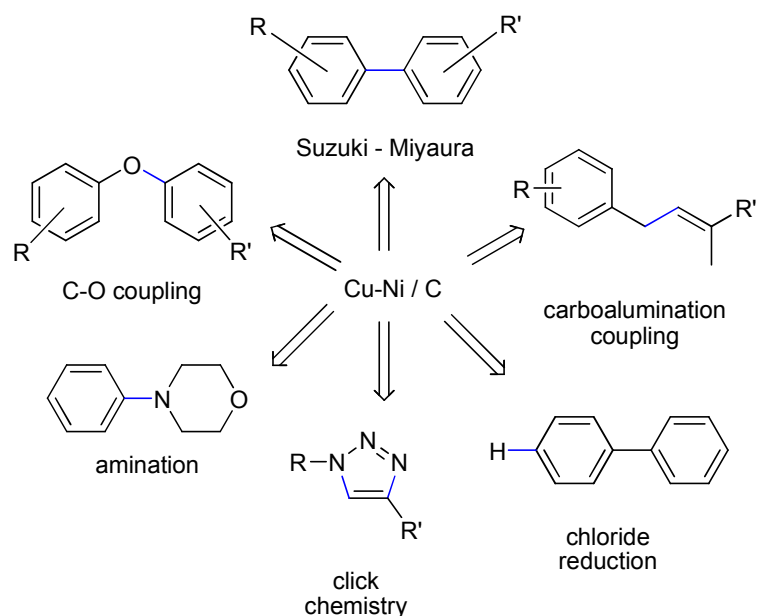

Scheme 49. Application of the Cu–Ni/C catalyst to different coupling reactions

In this study it was also shown that tandem processes could be performed using this catalytic system: click chemistry and C–N bond formation were performed on the same substrate, although the chemical yields were not excellent (54% overall yield, Scheme 50). Thus, this catalytic system proved extremely versatile for a variety of chemical transformations.

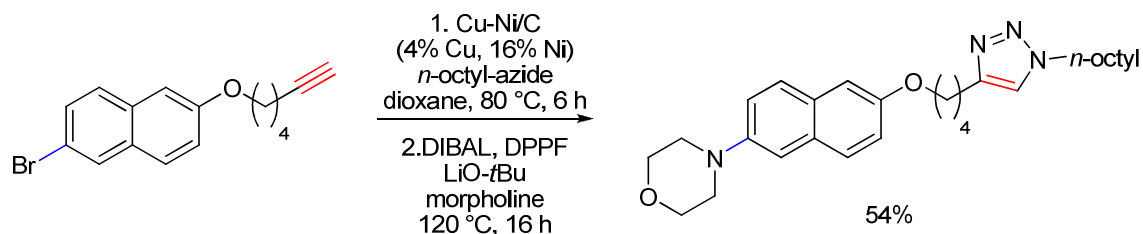

Scheme 50. Example of tandem process using the Cu–Ni/C catalyst

A copper(I)-catalyzed process has also proved reliable for the synthesis of a range of primary anilines from electron-rich and electron-deficient aryl halides with aqueous ammonia under microwave irradiation (Scheme 51).⁶⁸ With this methodology it was possible to avoid the use of expensive catalysts and ligands, or additional bases or additives, and an inert atmosphere was not required. It was possible to perform the reaction using aryl iodides and bromides and even the less reactive aryl chlorides, with a high tolerance of functional groups on the phenyl ring.

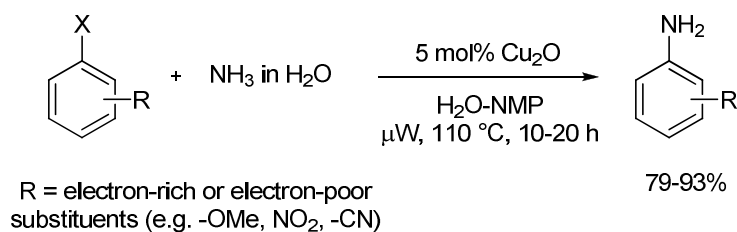

Scheme 51. Synthesis of primary amines *via* Cu(I)-mediated process

In a similar fashion to the palladium capillary system, the Organ group reported the copper-catalyzed microwave-assisted synthesis of propargylamines under continuous flow conditions (Scheme 52).⁶⁹ The three-component reaction of aldehydes, secondary amines and alkynes carried out in a copper-coated capillary tube gave the desired product with the prospect of efficiently scaling out the process. Under these conditions, the temperature of the microwave heated film was more than 900 °C.

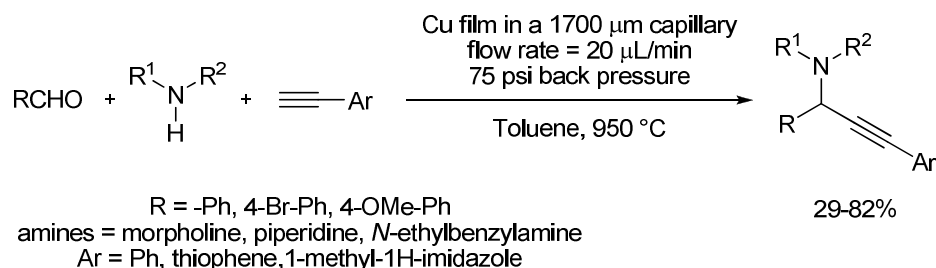

Scheme 52. Propargylamine synthesis as reported by the Organ group

A different example of propargylamine synthesis was very recently reported by the Van der Eycken group (Scheme 53).⁷⁰ Ketones, primary amines and alkynes were reacted using copper(I) iodide at 100 °C for 25 minutes with no solvent required. The use of a ketone, rather than an aldehyde, had never been reported previously, as well as the use of primary rather than secondary amines, as seen in the previous example. Nevertheless, the procedure afforded a set of propargylamines in moderate to very good yields.

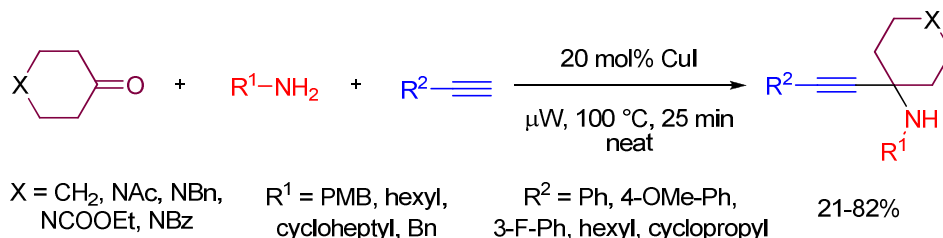

Scheme 53. Propargylamine synthesis as reported by the Van der Eycken group

1.2.4 Microwave-mediated Copper and Palladium Simultaneous Catalysis

In an example from the Piguel group in 2008, oxazoles were efficiently reacted with aryl bromides under ligand-free conditions.⁷¹ With this methodology, a range of 2,5-diaryloxazoles were prepared under microwave irradiation at 150 °C in a very short time (4 to 15 minutes) using catalytic amounts of palladium and a copper(I) species as additive (Scheme 54). These findings were applied to the synthesis of four natural alkaloids: texamine, texaline, balsoxin and *O*-Me-halfordinol.

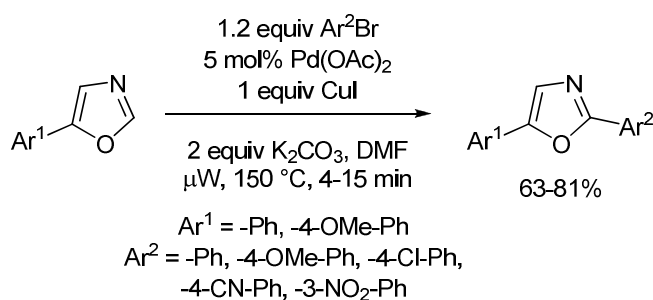

Scheme 54. Example of diaryloxazole synthesis under ligand-free synthesis

Modified Liebeskind-Srogl palladium(0)-catalyzed copper(I) conditions were used for the coupling of boronic acids with cyclic thioamides under neutral conditions, as shown by Kappe in 2007 (Scheme 55).⁷² Desulfurative C–C cross-coupling proceeded in 2 hours using microwaves at 100 °C, independent of the ring size, aromaticity or other functional groups present on the thioamides. It was also possible to direct the coupling towards carbon–sulfur bond formation by changing the catalyst system to copper(II) under oxidative conditions.

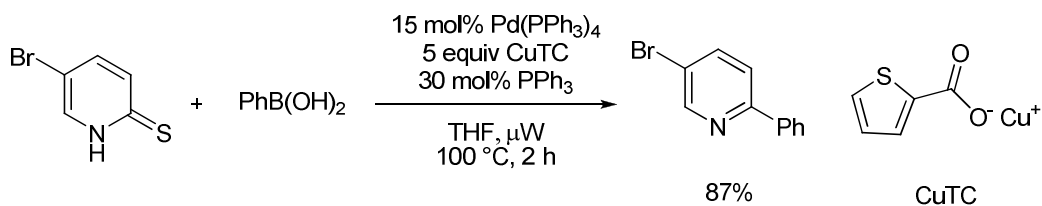

Scheme 55. Example of modified Liebeskind-Srogl-coupling by the Kappe group

The Goossen group in 2009 reported the use of a bimetallic catalyst system for the decarboxylative cross-coupling of aryl and acyl carboxylates with aryl triflates (Scheme 56).⁷³ Simultaneous use of copper(I) and palladium(II) in combination with the ligands of choice allowed the coupling between non-activated carboxylates and various functionalized aryl triflates. From a mechanistic point of view it was found that, moving from an aryl halide to an aryl triflate, the decarboxylation step was easier because of the absence of interference from

by-products (as the coordinating anions generated by the aryl halides). Because of this, the protocol had the advantage of widening the scope of aromatic carboxylates that could be used, with the possibility of shortening the reaction times down to 5-10 minutes by microwave irradiation (compared to 1-24 hours with conventional heating).

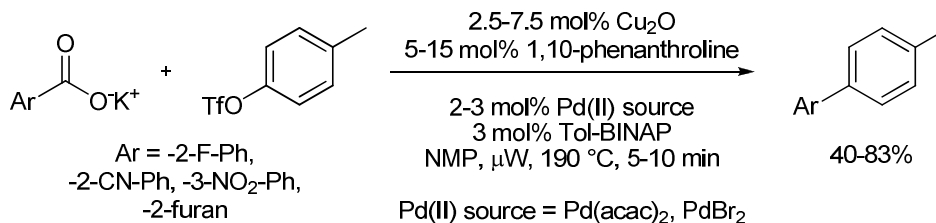

Scheme 56. Use of a bimetallic catalyst system in a decarboxylative cross-coupling

In the synthesis of thiopyranones, an important class of drug candidates with varied biological activities, a rapid and elegant method has been proposed by the Müller group in 2010.⁷⁴ A whole family of annelated 4*H*-thiopyran-4-ones was synthesized by a microwave-assisted sequence starting from readily-available (hetero)aryl chlorides, alkynes and sodium sulfide in a consecutive one-pot three-component reaction (Scheme 57). This class of compounds was found to be interesting for its halochromicity and fluorescence properties as well.

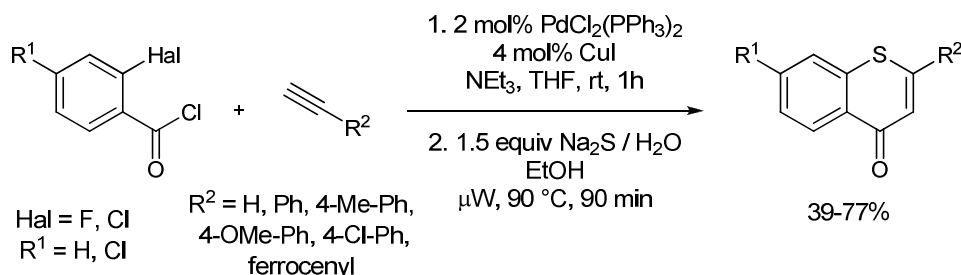

Scheme 57. Thiopyranone synthesis under Pd/Cu co-catalysis

1.2.5 Conclusions

It has been shown that microwave irradiation applied to copper- and palladium-catalyzed reactions improved these chemical processes by shortening the reaction times, retaining regio- and stereochemistry in some cases, and generally accelerating the reaction rates. Flow chemistry methods under microwave irradiation or using conventional heating have already found application in some of these processes and could deliver further improvements in the future for chemical processing of metal-catalyzed reactions.

1.3 Flow Reactors in Organic Synthesis

1.3.1 Introduction

In pharmaceutical companies major issues are raised by the need to produce large amounts of high-value products in a fast, convenient and safe manner. There are two possible approaches to large scale synthesis: one is the batch process approach, the other is a flow solution.

Using conventional batch chemistry, broadly speaking the processing rate is dependent upon the size of the reaction vessel - the larger the flask, the higher the output of the process. In flow synthesis the principal issue of material processing is now dependent upon other parameters such as operation time or flow rate.⁷⁵

In flow chemistry, a chemical reaction is performed in continuous flow in a network of interconnecting tubes: where tubes join one another, the fluids come into contact and the reaction takes place. Dosing time is then eliminated, resulting in constant mixture composition and avoiding the accumulation of unreacted reagents or products. The large surface-to-volume ratio of miniaturized fluid components allows an enhancement of the process control and faster heat transfer rates, resulting in a more accurate temperature control with major benefits especially for runaway reactions. Overall, side reactions are considerably reduced and safety considerations are improved.

A large amount of publications in the last few years has highlighted the value of this field of chemistry and, among these publications a book has been published recently (2008) that illustrates the application of microreactors in various field of organic chemistry and their application to process development and production.⁷⁶ Even more recently (2009), a thematic series on chemistry in flow systems from Beilstein Journals was published, illustrating the different fields in which microflow reactors are used in different areas of chemistry.⁷⁷

1.3.2 Microreactor design

Usually, microreactors consist of a system of interconnected microchannels (maximum internal volume in the range of mL), connected to a HPLC pump, a system pressure sensor and a back pressure regulator (as in Figure 4).

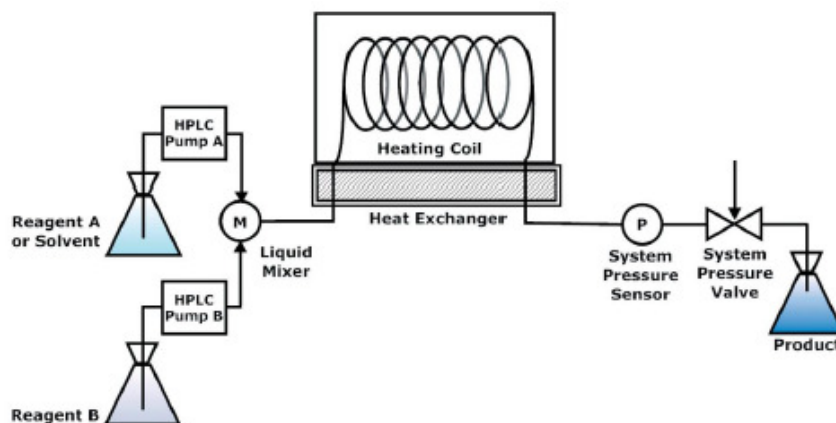

Figure 4. Usual setup for a microreactor device⁷⁸

For the dimensions of the channels, microreactors could be divided in microreactors (diameter between 10 to 300 μm) and meso or flow reactors (more than 300 μm and up to 5 mm in diameter) (according to the definitions of Dr. Paul Watts, University of Hull^a). Both these two types of reactors have unique advantages and disadvantages. Whereas in microreactors efficient mixing, together with fast and reliable heat and mass transfer, is ensured, because of the small size of the channels, a limited throughput is obtained compared to bigger mesoreactors. On the other hand, in mesoreactors a loss in mixing efficiency is experienced and the implementation of micromixers is needed in order to tackle this issue. As mentioned previously, the surface area/volume ratio is considerably larger in microreactors; from 10000 to 50000 m^2/m^3 compared to 1000 m^2/m^3 in laboratory vessels and 100 m^2/m^3 for production scale vessels. This characteristic enables efficient heat transfer and the possibility of side reactions can thus be reduced by rigorous temperature control. It is also possible to perform exothermic reactions under controlled conditions or reactions with explosive reagents in a safer manner, considering the minimization of chain or radical reactions (that could lead to explosions) in a microreactor. One of the ways to ensure efficient mixing is by laminar flow, which arises with a low Reynolds number. The Reynolds number (Re) is a dimensionless parameter that relates inertial and viscous forces:

$$Re = \rho v L / \mu$$

where ρ is the density, v the velocity, μ the viscosity of the fluid mass and L the diameter of the channel. With values between 1 and 2300, the flow is dominated by viscous forces and it is defined as laminar. With values greater than 3000, inertial forces dominate and the flow is

^a From Paul Watts presentation at NIChe conference, 21-23 September 2009.

defined as turbulent (Figure 5). When the Reynolds number is between 2300 and 3000, the flow is neither laminar nor turbulent but the transition between them occurs gradually.

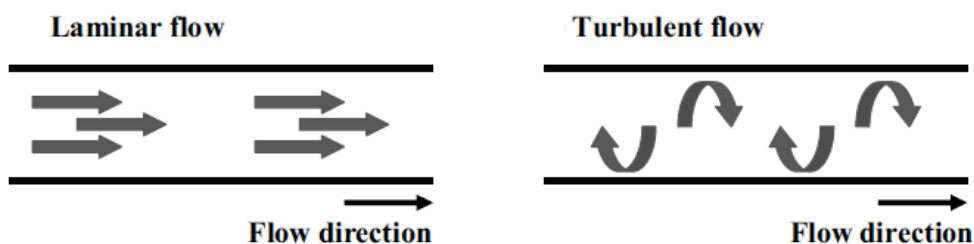

Figure 5. Laminar vs. turbulent flow⁷⁶

It is also possible to relate the viscous and inertial forces to the surface tension using Capillary and Weber numbers. The Capillary number (Ca) is a dimensionless parameter that relates viscosity with surface tension:

$$Ca = \mu v / \sigma$$

where μ is the viscosity of the fluid, v the velocity and σ the surface tension. The Weber number (We) is a dimensionless parameter that relates inertial forces with surface tension:

$$We = \rho v^2 l / \sigma$$

where ρ is the density of the fluid, v the velocity, l the channel length and σ the surface tension. With a low Reynolds number, the viscosity is dominant over the inertial forces. On a different angle, another parameter relates surface tension to gravitational force, as expressed by the Bond number (Bo):

$$Bo = (\Delta\rho) g d_h^2 / \sigma$$

where $\Delta\rho$ is the density difference between two immiscible liquids, g the gravity acceleration, d_h the channel dimension and σ the surface tension.

Microreactors are usually made of glass or stainless steel but it is possible to use silicon or plastic as well to enhance the heat transfer and chemical resistance (to solvents or acids and bases) and physical resistance (high pressure or temperature). Size and geometry may vary: it is possible to find simple tubular structures or more complex multicomponent circuits with single-element structures or multi element parallel structures (Figure 6).

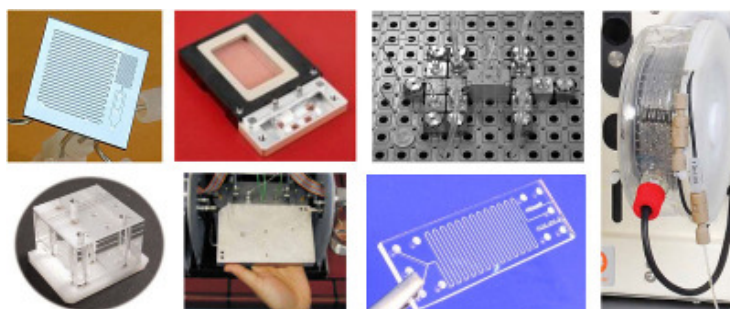

Figure 6. Different types of microreactor⁷⁹

1.3.3 Commercial and non-commercial devices

A range of commercial instrumentation has been developed in the last decades, allowing ready access to flow chemistry for academia and both small and large companies. FutureChemistry FlowStart is a complete package made of syringes, pumps, microreactors and temperature controller to carry out experiments under flow processing.⁸⁰ The same company also supplies the FlowScreen to perform automated operations, reaction optimisation and process validation (Figure 7).



Volume of standard syringe: 1 mL
Max. pump pressure: 7.14 bar (100 psi)
Min. pump rate: 0.73 μ L/h
Max. pump rate: 35 mL/h
Wetted parts: PEEK, PTFE, FEP, glass
Temperature range: 0 – 90 °C
Heating speed (22 to 90 °C): 36 s
Cooling speed (22 to 0°C): 27 s

Figure 7. Future chemistry FlowScreen instrumentation specifications⁸⁰

The temperature range of these devices is between 0–90 °C, with a maximum pump pressure of 100 psi and maximum pump rate of 35 mL/h (580 psi and 37 mL/h for the FlowScreen). A different instrument is supplied by Thales Nano,⁸¹ which allows catalyst and reaction screening using a flow system under high conditions of temperature and pressure. Specifically, the H-Cube Pro™ is able to perform hydrogenation reactions using the electrolysis of water to generate hydrogen (Figure 8).



Max. pressure: 100 bar (1400 psi)
Min. pump rate: 3 mL/min
Max. pump rate: 25 mL/min
Wetted parts: PEEK, stainless steel
Temperature range: r.t. – 150 °C

Figure 8. The Thales Nano hydrogenation instrument specifications⁸¹

It is possible to heat the reaction chamber up to 100 °C (maximum value of pressure: 1450 psi). The mixture flows through a catalyst cartridge (with different catalyst solutions provided) where the hydrogenation takes place. A distinct advantage of the setup is the ease of catalyst exchange, with no filtration required, and no requirements of an external gas source.

One of the latest products from the same company, introduced to perform homogeneous organic synthesis in continuous flow mode, is the X-Cube Flash™ (Figure 9).⁷⁸ This instrument uses stainless steel coils of variable length (from 4 to 16 mL of volume) that could be heated up to 350 °C and pressurized up to 2900 psi, reaching supercritical conditions for quite a number of solvents. One or more standard HPLC pumps introduce the reaction mixture into the coils at a flow rate range between 0.01 and 10 mL/min.



Pressure range: 50 bar – 200 bar (725 -
2900 psi)

Temperature range: 25 – 350 °C

System material: Stainless Steel

Coil id: 1000 µm

Loop volume: 4 mL – 8 mL – 16 mL

Flow rate range: 0.1 – 9.99 mL/min

Figure 9. Thales Nano X-Cube Flash™ specifications⁷⁸

Uniqsis launched recently onto the market a new continuous flow reactor called FlowSyn™ (Figure 10).⁸² This system is able to scale-up flow reactions to gram scale in a safe environment (due to the on-time pressure monitoring and protective shielding), heating up to 260 °C (maximum pressure value 1000 psi). Different sizes of reaction coils (from 1.4 to 40 mL) of different materials could be used and could be linked to an OMNIFIT® glass column reactor (10 mm id x 100 mm) with peek end fittings, where it is possible to pack immobilized reagents.



Coil reactor volume: 1.4 – 2 – 2.5 – 5 – 10
– 20 – 40 mL

Coil reactor id: 1000 μ m to 1600 μ m

Column reactor id: 6.6 or 10 mm

Coil wetted parts: PTFE, PFA, Steel,
Hastelloy[®]

Temperature range (coil): r.t. – 260 °C

Temperature range (column): r.t. – 150 °C

Back pressure regulator: 0 – 300 psi or 100
– 1500 psi

Figure 10. Uniqsis FlowSyn™ specifications⁸²

A similar instrument has been released by Vapourtec, called the R series system, which allows one to perform reactions at temperatures as low as -70 °C using a cooled reactor system (Figure 11).⁸³ Two reactor positions are provided in different sizes (2, 5 or 10 mL), which are highly resistant to corrosive reagents and independently controlled. The visibility of the processing system accounts for the real-time identification of gas generation or in-line precipitation.



Coil reactor volume: 2 mL – 5 mL – 10
mL

Column reactor id: 1000 μ m to 1500 μ m

Wetted parts: PFA, Steel, Hastelloy[®]

Temperature range(coil): -70 – 250 °C

Temperature range (column): -40 – 150 °C

Max pressure: up to 700 psi

Figure 11. Vapourtec R series cooled reactor specifications⁸³

Labtrix in the Netherlands has proposed laboratory scale instrumentation, the Chemtrix Start (Figure 12), with which it is possible to perform different types of chemistry at a range of temperatures between -15 and 195 °C.⁸⁴ A back pressure regulator allows pressure to be built in the etched glass microreactor up to 15 bar and syringe pumps allows for a flow rate range between 0.1 and 100 µL/min, depending upon the volume of the syringe and the residence time. Different materials could be used for the wetted parts: PEEK, PTFE, FEP or glass, depending on the nature of the reaction mixture.



Volume of standard syringe: 1 mL
 Min. pump rate: 0.1 µL/min
 Max. pump rate: 100 µL/min
 Wetted parts: PEEK, PTFE, FEP, glass
 Temperature range: -15 – 195 °C
 Max pressure: up to 350 psi

Figure 12. Chemtrix Labtrix and specification⁸⁴

A dedicated instrument specifically designed to perform microsynthesis of PET labelled compounds using small quantities of reagents under controlled reaction conditions is the Advion Nanotek[®] (Figure 13).⁸⁵ Fast synthesis from a single ¹⁸F batch could be carried out even at high values of pressure and temperature (up to 210 °C and 400 psi) and with high tolerance to a range of solvents. Different coil sizes are available (2 to 4 m) and flow rates range between 5 and 100 µL/min.



Coil reactor id: 100 µm
 Coil reactor size: 2 – 4 m
 Wetted parts: fused silica
 Temperature range (coil): r.t. – 210 °C
 Back pressure regulator: 0 – 400 psi
 Flow rate range: 5 – 100 µL/min

Figure 13. Advion Nanotek[®] specifications⁸⁵

A fully automated and integrated flow chemistry system from Syrris is also on the market. The Africa[™] system allows flow synthesis, analysis, aqueous work up and product collection in one system (Figure 14).⁸⁶ The Africa[™] instrument uses etched glass microreactors of different volumes

(from 62.5 to 1000 μ L) and can operate at temperatures from 0 $^{\circ}$ C to 250 $^{\circ}$ C under pressures of up to 7 bar. The syringe pumps allow flow rates from 2.5 μ l to 2.5ml/min and have a range of different loop volumes (1, 5 and 10 mL). One of the modules allows in-line analysis of a reaction sample by HPLC to monitor the course of a reaction. A separate module called FLLEX (Flow Liquid-Liquid EXtraction) allows for in-line aqueous workup, with two immiscible phases to be mixed and separated in flow.



Microreactor volume: 62.5 μ L, 250 μ L and
1000 μ L

Max. back pressure: up to 7 bar (98 psi)

Min. pump rate: 2.5 μ L/min

Max. pump rate: 2.5 mL/min

Wetted parts: PEEK, PTFE, glass

Temperature range: 0 – 250 $^{\circ}$ C

Figure 14. Syrris Africa™ specifications⁸⁶

All the instrumentation so far described makes use of conventional heating to warm up the microreactor. A different solution has been reported by the Bagley group that makes use of microwave heating to carry out reactions in flow mode.⁸⁷ By using a standard CEM microwave synthesizer, a standard 10 mL Pyrex tube was fitted with a custom built plastic steel head and filled with sand (~12 g) held between two drilled frits (Figure 15). The inlet tube of the flow cell was connected to a HPLC pump and a back pressure regulator (100 psi) was connected to the outlet tube, allowing experiments to be run under pressure. The flow cell was inserted into the cavity of the CEM Discover[®] microwave synthesizer.

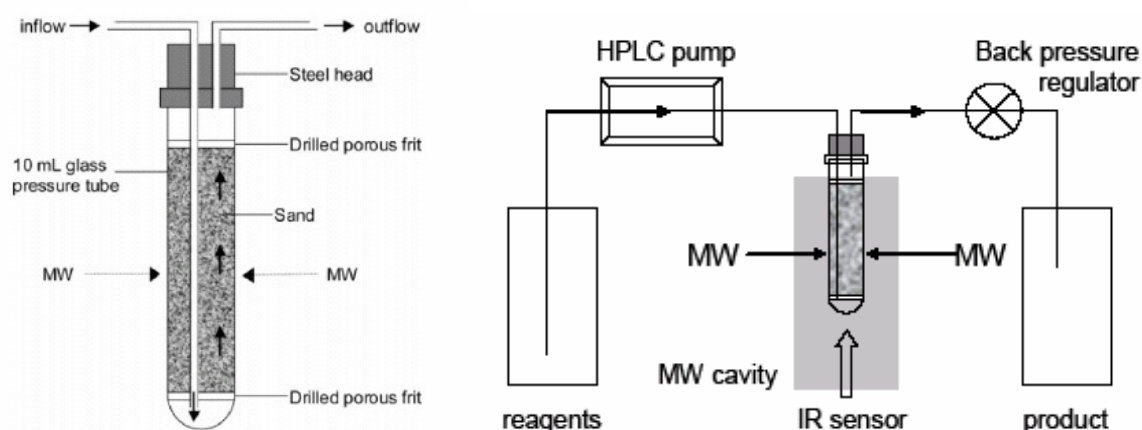

Figure 15. Design of the 10 mL microwave flow cell tube reactor⁸⁷

Feed-back microprocessor control was connected to the CEM Discover[®] microwave synthesizer, thereby allowing the operator to preset temperature, power, cooling and to monitor the temperature-pressure and power profile of reactions.

The same setup could be used with an 80 mL tube, the only difference being in the way the temperature would be measured: an additional inlet present in the head allows a fiber optic probe to be used for temperature measurement (Figure 16). A back pressure regulator (100 psi) can be connected to the outlet tube, allowing a maximum pressure of 200 psi.



Figure 16. 80 mL flow cell setup²

A commercially available device has been devised by MilestoneSci, called FlowSynth, which performs flow reactions at large scale under microwave irradiation (Figure 17).⁸⁸ A vertical PTFE-TFM flow-through reactor with a volume of 200 mL passes through the cavity of a multimodal microwave synthesizer, the Batchsynth, where it is possible to heat reaction mixtures up to 200 °C at a working pressure of 435 psi. Reagents are pumped in from the bottom of the reactor at a flow rate range of 12 to 100 mL/min. The reaction products then flow out the top into a water-cooled heat exchanger. The temperature is measured *via* in-line sensors present in the microwave cavity. An overhead motor, driving an Archimedean screw, controls the plug-flow characteristics of the reaction solution, whereas heating inside the reaction vessel is aided by Weflon baffles, which strongly absorb microwaves and hence transfer thermal energy.

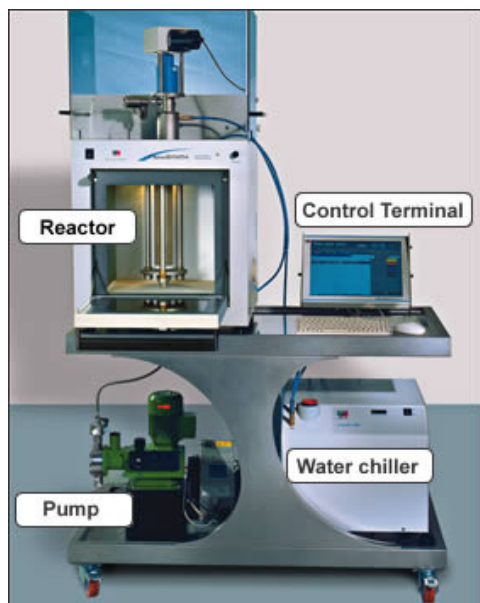

Reactor volume: 200 mL
Min. pump rate: 12 mL/min
Max. pump rate: 100 mL/min
Wetted parts: PTFE-TFM
Temperature range: 0 – 200 °C
Max pressure: up to 420 psi

Figure 17. Milestone FlowSynth specifications⁸⁸

The Milestone BatchSynth is the batch version of the FlowSynth microwave synthesizer.⁸⁹ The same cavity is used, with in-line temperature sensors to monitor the temperature. Different vessels (made of quartz or TFM) with excellent heat transfer capability are available, having volumes between 12 and 270 mL and a cavity on the top to insert a fiber optic to measure the temperature at the centre of the microwave tube. These vessels could be heated up to 240 °C at a maximum pressure of 55 bar.

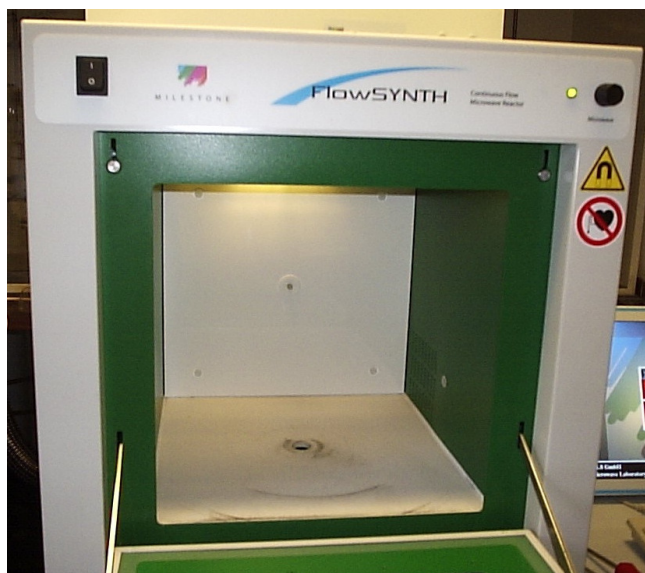
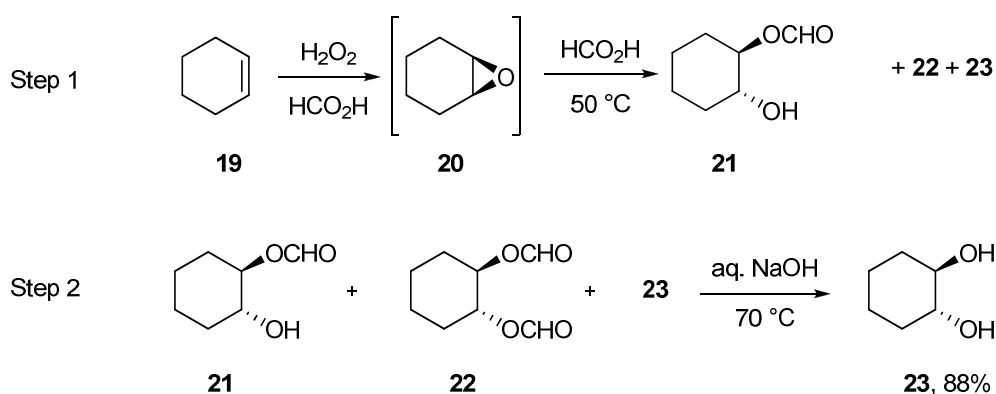

Figure 18. Milestone BatchSynth cavity⁸⁹

1.3.4 Applications in chemical synthesis

All the instrumentation described herein has found practical application in various fields of chemistry. Significant advantages can be found in the use of flow devices for the synthesis of chemical intermediates, as shown by the work of Kraft and co-workers.⁹⁰ They compared the synthesis of *trans*-1,2-cyclohexanediol (Scheme 58) in batch and flow mode and found relevant advantages in the scale-up of this compound using a simple flow set up (Figure 19). The batch synthesis was performed at 70 °C (for the first step) and 90 °C (for step 2). The reaction was exothermic and a large amount of solvent was required to dilute the reagents in order to keep the temperature profile of reaction under control. Moreover the final diol needed further purification to provide a high purity sample. In the continuous flow setup, step 1 of the synthesis was performed at 50 °C and complete conversion was achieved in a contact time of just 1 minute. It was possible to use a more concentrated solution of hydrogen peroxide and the ratio of products obtained were significantly different compared to the batch synthesis (**21/22/23**: 1/0.1/0.4 in flow, compared to 1/1.3/0.1 in batch). The second step was conducted at 70 °C with a contact time of just half a minute using a cyclic flow system to force the hydrolysis to completion. With this setup, it was possible to control the amount of sodium hydroxide used and the amount of waste salts formed as by-products of the reaction. Overall, the diol was obtained in similar yield to the batch process (88% instead of 86%) but in substantially higher purity, as shown by a sharper melting peak (from calorimetry studies), elemental analysis and a higher melting point, when compared with the recrystallized batch product.



Scheme 58. Synthesis of *trans*-1,2-cyclohexanediol

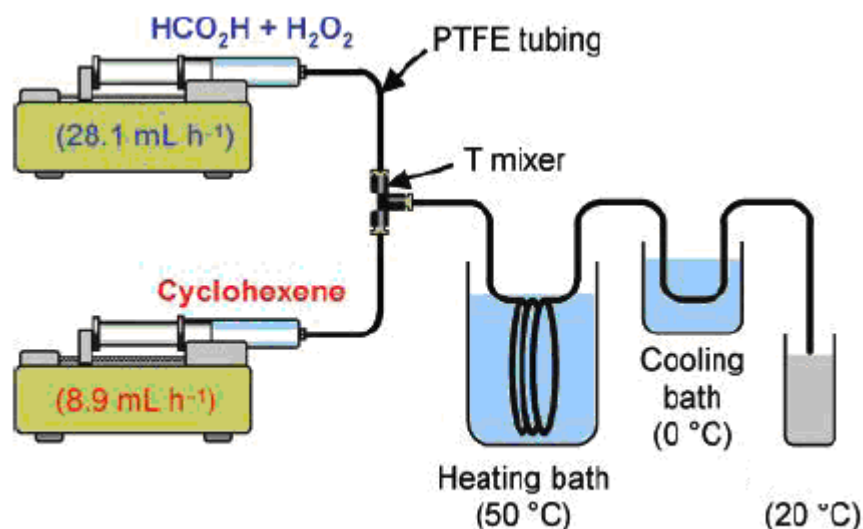
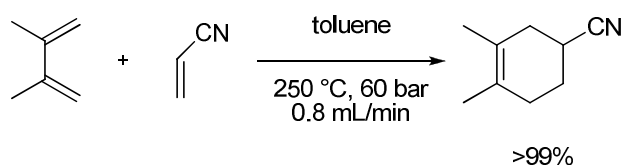

Figure 19. Microreactor setup for step 1⁹⁰

In 2009, Kappe's group reported application of the Thales Nano X-Cube Flash™ reactor to a variety of homogeneous chemical transformations under high temperature/high pressure conditions providing a direct comparison to microwave-mediated conditions.⁷⁸ The first reaction analyzed was the Diels-Alder reaction of a butadiene with acrylonitrile (Scheme 59). Under microwave irradiation, the cyclohexene adduct was obtained after 20 minutes at 240 °C and similar conditions were applied in the microreactor device. Full conversion was obtained at 250 °C after 5 minutes (using a 4 mL coil), with the possibility of using other solvents with lower boiling points (THF, acetonitrile or DME) with identical results compared to toluene.



Scheme 59. Diels-Alder reaction

The useful Newman-Kwart rearrangement was the second example considered. The *O*- to *S*-aryl migration is believed to require high temperatures and the transformation could be conducted in NMP using microwave irradiation at 220 °C for activated substrates but at more than 300 °C for deactivated ones. Transferring the process to the microreactor, the reaction was carried out at 220 °C for compound **24a** and at 300 °C for compound **24b** in no more than four minutes, using DME as solvent to avoid any aqueous workup (Scheme 60). At those temperatures, DME is believed to be under superheated conditions.

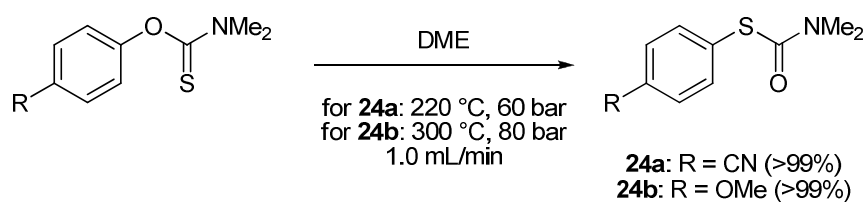

Scheme 60. Newman-Kwart rearrangement

The Claisen rearrangement of an allyl phenyl ether was tested as well (Scheme 61). With microwave batch irradiation, the reaction was complete in 1-2 hours at 250 °C whereas in flow mode the same transformation was conducted at 240 °C and was complete in minutes. Modifications to the reaction temperature gave incomplete conversions with an increased amount of side products.

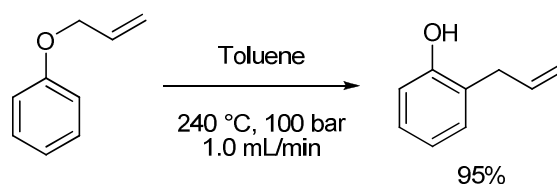

Scheme 61. Claisen rearrangement

The Fisher indole synthesis has been the subject of several studies into the use of microwave assistance, so Kappe's group analyzed the transfer of this protocol to a microreactor (Scheme 62). An exact replication of the microwave-mediated literature conditions (AcOH, 150 °C, 4 min) afforded the compound in comparable yield but reinvestigation of the process in order to scale it up gave an even better result. The reaction was carried out at 200 °C in a 16 mL coil with a residence time of 3 minutes and it was possible to obtain 25 g of product in 1 hour of processing.

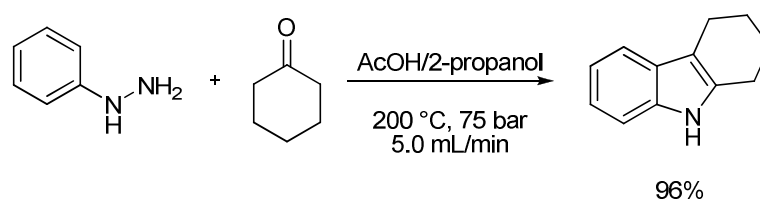

Scheme 62. Fisher indole synthesis

Other transformations were tested in the X-Cube Flash™ reactor and significant advantages were in evidence over the related microwave batch process. Shorter reaction times, due to more efficient heat transfer and control of reaction pressure and temperature, and ease of workup were distinct features of all of the transformations conducted in microdevices.

Moreover, the ability to superheat the solvents of choice proved a key benefit for successful outcome.

An example of flow chemistry applied to the synthesis of active pharmaceutical ingredients was given by the McQuade group in 2009.⁹¹ They reported a three-step synthesis of ibuprofen, with a retrosynthetic analysis that considered the synthesis as a whole. In this way they were able to avoid purification and isolation steps by finding byproducts and excess reagents of one reaction to be compatible with downstream reactions. As shown in Scheme 63, the initial Friedel-Crafts acylation was conducted by mixing *iso*-butylbenzene with propionic acid in the presence of triflic acid as catalyst for 5 minutes at 150 °C, to give the product in 91% yield. This reagent system was chosen because of its compatibility with the second step: in fact, the product from step 1 was not isolated but directly mixed with trimethyl orthoformate (TMOF) and $\text{PhI}(\text{OAc})_2$ to carry out the 1,2-aryl migration. The second step was run for just 2 minutes at 50 °C, obtaining the product in 70% yield (for the two steps). Final hydrolysis was performed by adding aqueous methanolic potassium hydroxide to the outlet stream of the previous steps, heating at 65 °C for 3 minutes. The acidic stream could be safely mixed with the base, due to efficient heat transfer and excellent temperature control in the microreactor. Ibuprofen was then obtained in 51% yield after recrystallization, with no isolation of intermediates and with a production rate of 9 mg/min of crude product.

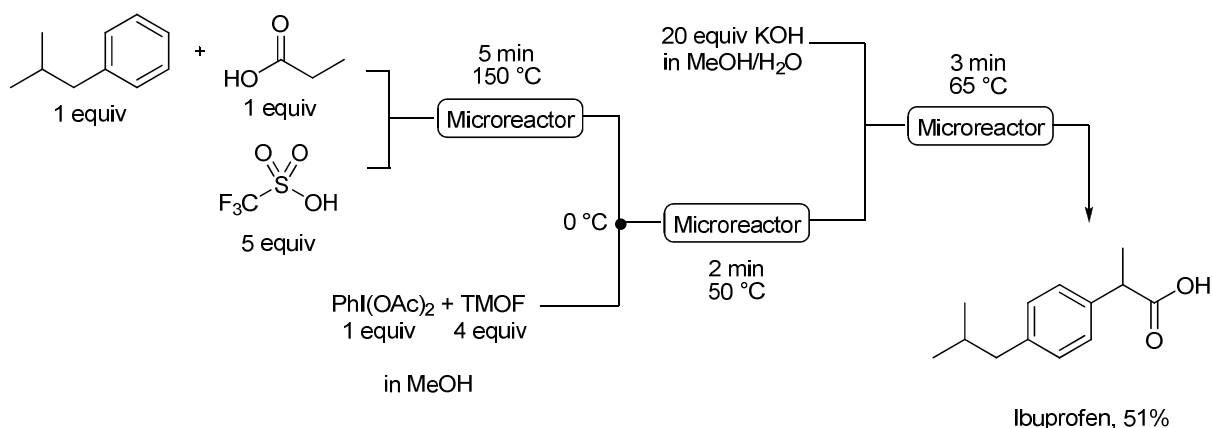

Scheme 63. Three step synthesis of ibuprofen

A similar example of synthesis with no need of workup and purification of the intermediates has been recently described by the Cosford group.⁹² In 2010 they reported the first continuous flow synthesis of imidazo[1,2-*a*]pyridine-2-carboxamides, heterocyclic scaffolds present in different compounds with anticancer, antiviral and antimicrobial activities (Scheme 64). Initial investigations were conducted to perform the continuous flow synthesis of related carboxylic acids, by mixing 2-aminopyridines (or 2-aminopyrimidines) and bromopyruvic

acid in the presence of a catalytic amount of *p*-toluenesulfonic acid in DMF at 125 °C for 10 minutes. A variety of carboxylic acids were obtained, with functionalization on the pyridine ring. This investigation was then expanded to the synthesis of the carboxamide derivatives. Optimization studies were conducted in order to carry out the second reaction directly after the first and to avoid possible side reactions. The best conditions were found with removal of the catalyst from the first reaction and separate addition of solutions of EDC/HOBt and the corresponding amine/*N,N*-diisopropylethylamine (DIPEA) in the second step. The second reaction was performed at 75 °C for 10 minutes, giving the corresponding carboxamide in good yield in a single continuous process; various amines could be used to further functionalize the products.

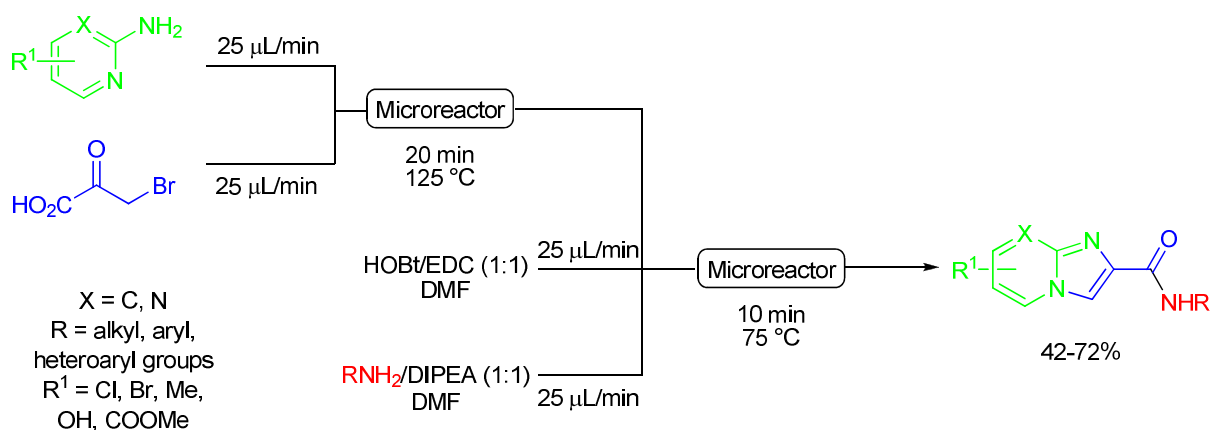

Scheme 64. Fully automated CF synthesis of heterocycles

Very recently in the literature a new application of flow chemistry for the preparation of fluorinated compounds has been published (Scheme 65).⁸⁵ Reactions were run in a commercial microreactor instrument (the Advion NanoTek[®]). The fluoride ion complex was loaded in one loop of the microreactor, with the second loop charged with the diaryliodonium salt, as shown in Figure 20, heating the microreactor at 110 °C. The radiolabelled fluoroarene was obtained in 85% yield in no longer than six and a half minutes. Interesting studies on the influence of *ortho*-substituents present on the diaryliodonium salts in the fluoridation reaction were also conducted. It was shown that, in the case of unsymmetrical salts, two products were obtained (as shown in Scheme 65) and the selectivity was given by the nature of *ortho*-substituents. An *ortho* effect was deduced, with 2,6-dimethyl substituents being the most powerful in directing the substitution and methoxy groups the least powerful.

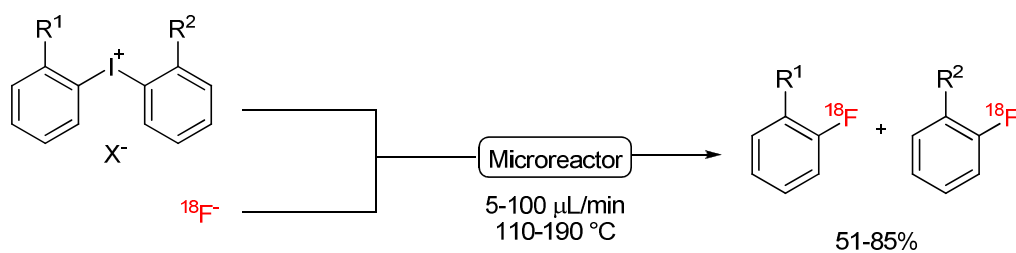

Scheme 65. Flow-mediated radio fluoridation reaction

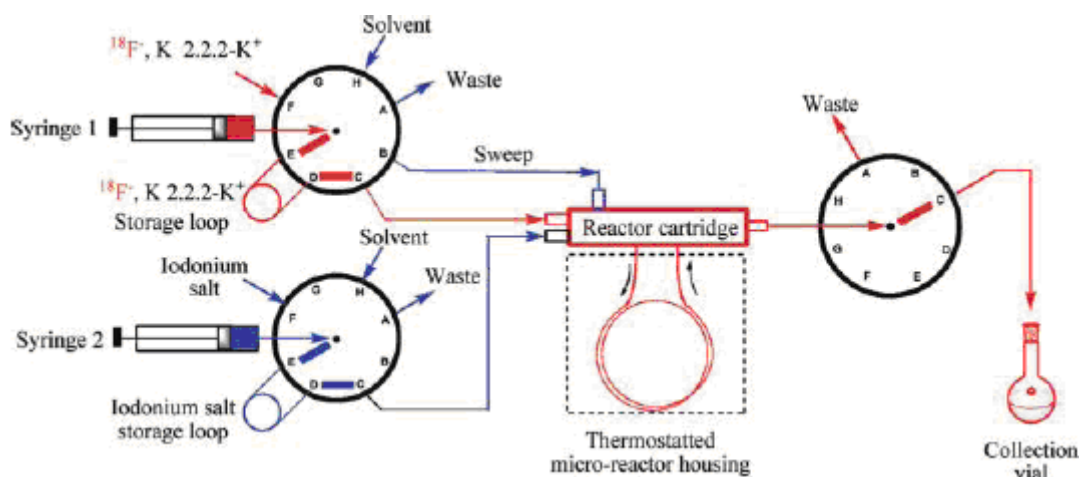
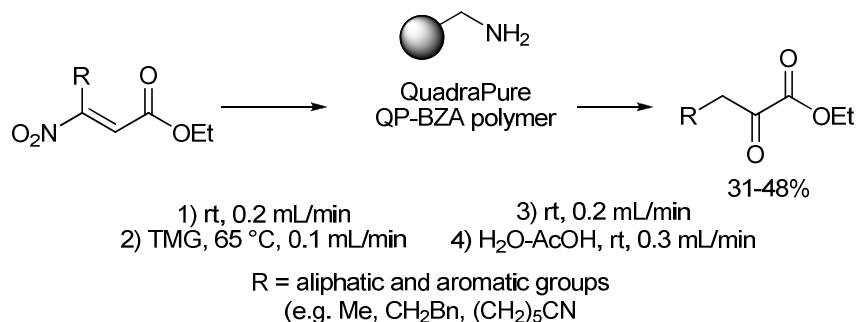

Figure 20. Microflow setup for radio fluoridation reaction⁸⁵

In 2009, the Ley's group reported the synthesis of α -ketoesters using the catch-and-release protocol in a UNIQUIS FlowSyn™ continuous flow reactor.⁸² As shown in Scheme 66, the nitroolefinic ester was captured on the benzylamine polymer (packed in the column reactor), then the mixture was treated with tetramethylguanidine (TMG) to eliminate the nitrous acid and give the enamino acid esters. The system was then washed and hydrolysed to give the final product.



Scheme 66. Synthesis of α -ketoesters

In a similar fashion, the synthesis of the nitroolefinic esters previously used as starting materials was conducted in flow mode starting from nitroalkanes and ethyl glyoxalate

(Scheme 67). This example of the Henry reaction was conducted using Amberlyst™ 21 and the product was then treated with trifluoroacetic acid and triethylamine in toluene and passed into the reactor coil at room temperature to afford the desired product in 60% yield. The nitroolefinic ester could be used directly for the synthesis described in Scheme 66, given the removal of impurities by immobilization of the intermediate *via* a solid-supported phase.

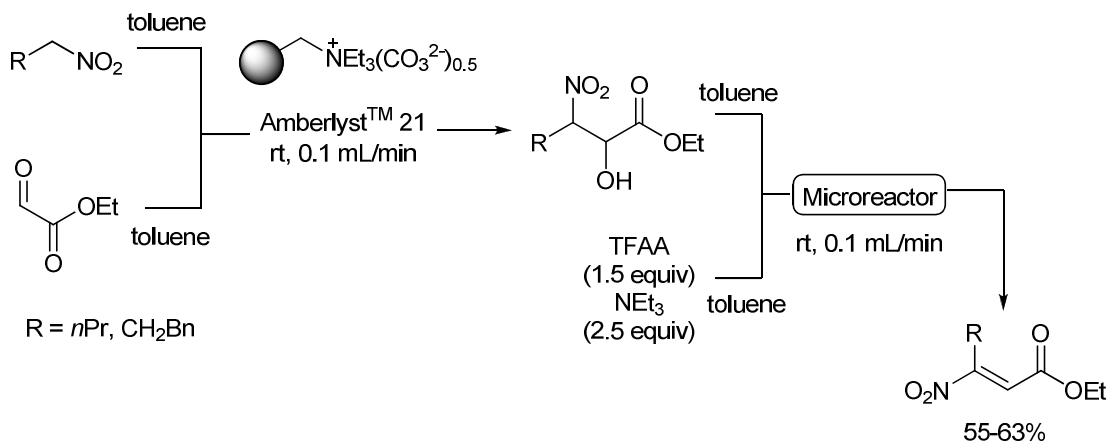

Scheme 67. Synthesis of nitroolefinic esters

An example of the continuous flow synthesis of hydroxamic acids using the Vapourtec R Series system was reported in the literature in 2009.⁹³ Initial investigation was conducted using a mixture of methylbenzoate and hydroxylamine in the presence of a solution of sodium methoxide in methanol (Scheme 68). Complete conversion to the corresponding hydroxamic acid was obtained in 30 minutes at a temperature of 70 °C without formation of the carboxylic acid as by-product (that was formed at higher temperatures). Using the same conditions in batch mode or even using microwave instrumentation provided the product in lower yields, significantly lower in the batch mode (58%), and in lower purity. The reaction scope was then expanded with the synthesis of a small library of compounds and further application to the synthesis of an histone deacetylase inhibitor. Carrying out the reaction in microreactors allowed the safe handling of the potentially explosive hydroxylamine and the easy scalability of the entire protocol just by using the setup for a longer time or by the numbering-up process.

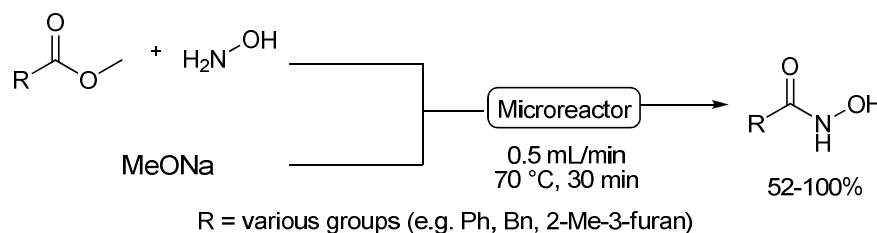

Scheme 68. Continuous flow synthesis of hydroxamic acids using the Vapourtec system

Iodine azide is a dangerous chemical to be handled but, under microreactor conditions, it is possible to perform reactions using this compound in a safe and controlled manner, as shown by Wirth in 2009.⁹⁴ In their approach to the formation of carbamoyl azides *via* Curtius rearrangement, the Wirth group generated the iodine azide *in situ* from iodine monochloride and tetrabutylammonium azide, as shown in Scheme 69. The selected aldehyde was then added to the reaction mixture and the reaction performed in the microreactor at 80 °C using acetonitrile as solvent, obtaining the desired product in moderate yields (21 to 44%). Although the chemical yields were not high, this study did show that the highly explosive and toxic iodine azide could be safely used in microstructured devices, allowing azide chemistry to be performed without major safety concerns.

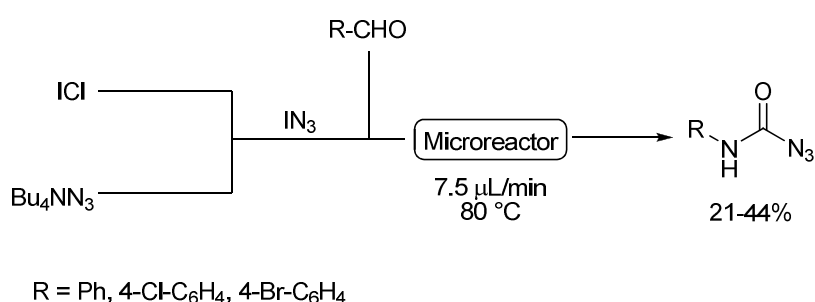

Scheme 69. Microreactor setup for in situ generation of iodine azide

The Curtius rearrangement was the model system for investigating the continuous multistep synthesis of carbamates, as reported by Jensen in 2007 (Scheme 70).⁹⁵ Glass-coated silicon-based microreactors were chosen to perform this type of chemistry to use the inertness of the glass with the high heat transfer properties of silicon. Three microreactors were combined with two microseparators, as shown in Figure 21, in order to carry out the reaction process from beginning to end without the need to isolate intermediates, or carry out any external workup operations. The initial conversion of aryl chloride to azide was performed in the first microreactor and proceeded in quantitative yield (98% after 200 minutes), with subsequent separation of the aqueous from the organic phase in the connected microseparator. The following conversion to isocyanate was performed in the second microreactor in the presence of an acid catalyst to speed up the process: the desired product was obtained in 99.9% yield in 1 hour at 90 °C. A second microseparator was then used in order to remove the leftover gas evolved from the previous reaction. Finally, in the third microreactor an alcohol was added to the mixture to give the carbamate. The conversion was rapid and efficient, giving the product in 96-99% yield. This work demonstrated the possibility of performing multistep synthesis in continuous mode with *in situ* generation and consumption of dangerous chemicals and safe handling of these in the microreactor.

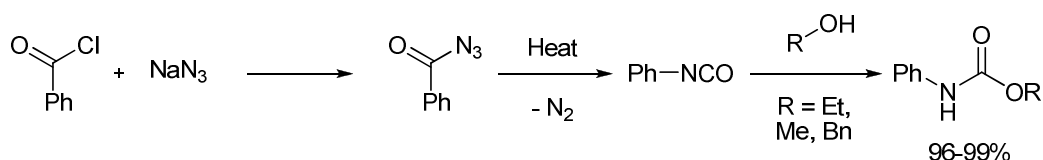

Scheme 70. Curtius rearrangement to carbamates

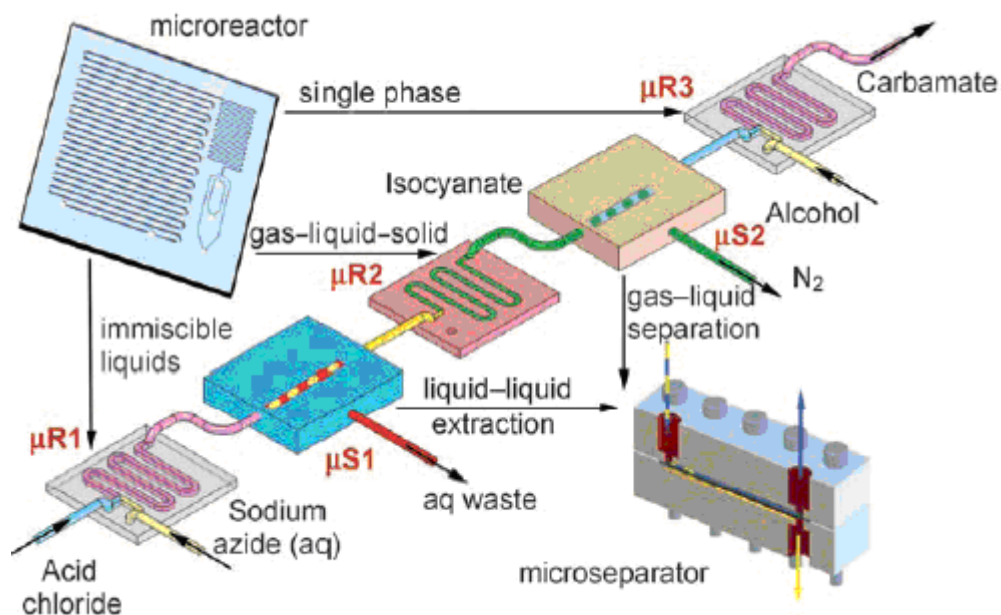
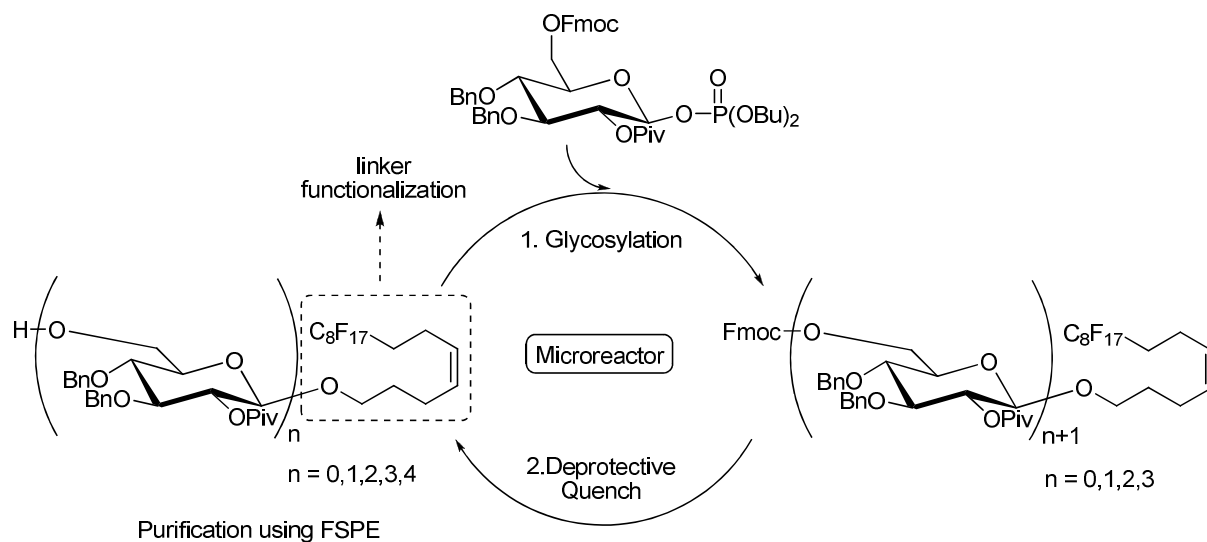

Figure 21. Multistep continuous flow microchemical synthesis⁹⁵

The first example of oligosaccharide synthesis in microreactors was reported by the Seeberger group in 2007.⁹⁶ A silicon-glass microreactor was used to carry out the iterative glycosylations at room temperature and it was chosen because of its characteristic good thermal conductivity and stability to solvents and reagents. Complete conversion to tetrasaccharide was carried out as showed in Scheme 71 in an iterative way. The glycosylation reactions were performed by mixing the fluorinated acceptor, glycosyl phosphate and TMSOTf as activator in dichloromethane or TBT as solvent. The deprotective quench was performed using a mixture of piperidine/DMF and TBAF to cleave the Fmoc group. A distinctive advantage of the glycosylation reactions carried out in the microreactor environment, compared to batch synthesis, was the ability to perform the reactions in a short reaction time and at higher temperature. The perfluorinated linker allowed for easy purification *via* fluorosolid-phase extraction and could act as a site for further functionalization of the oligosaccharides.



Scheme 71. Oligosaccharides synthesis using microreactor technology

Another comparison between microwave and microreactor instrumentation was conducted for the formation of β -amino alcohols, as shown by Jensen and co-workers in 2010.⁹⁷ In their investigation they decided to use a silicon microreactor system, coating the silicon channels with silicon nitride to ensure higher resistance to any solvent and chemical conditions. Moreover, the thermal conductivity of silicon helped the transfer of heat within the microchannels. Initial tests were conducted using a variety of substrates: in all of the cases investigated, the results from the microreactor reaction were able to match the comparable microwave-mediated process. One substantial feature of the microreactor medium was the possibility to heat the solvent of choice above its boiling point with the result of shortening the reaction times without a significant loss of yield. These findings were applied to the synthesis of pharmaceutically relevant β -amino alcohols such as metoprolol **25** (Scheme 72). This compound has importance in the treatment of hypertension and its batch synthesis requires from 2 to 5 hours using several equivalents of isopropyl amine at reflux in a protic solvent. The microwave-mediated process required 30 minutes at 150 °C giving **25** in 65% yield but produced a significant quantity of the bis-alkylation product **26** (31%). Using the 120 μ L microreactor, it was shown that formation of **25** was complete in just 15 seconds at 240 °C in 91% yield and the formation of **26** was reduced (6%), with the possibility of process scale-up to give a processing rate of product of 7 g/ hour.

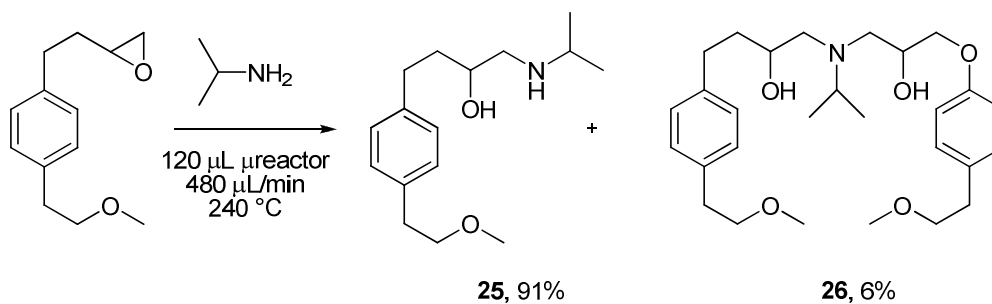

Scheme 72. Metoprolol (**25**) synthesis

1.3.5 Conclusions

Applications of microreactor technology to organic synthesis can have a major impact on the way each reaction step is performed. It is possible to integrate this new technology into day-to-day experiments and improve many processes. Limitations of microreactor technology are still evident in precipitation events and the inability of these instruments to use solid reagents, but by moving to homogeneous reactions with a deep understanding of reaction pathways in microreactors, many of these issues can be overcome, making continuous flow processing one of the major recent advances for “greener” chemical synthesis.⁹⁸

Chapter 2: Heterocycle synthesis under microwave irradiation

2.1 Goals of This Study

The assumption that reactions readily optimized using a conductive heating microreactor platform, or automated microwave-assisted batch reactor, can be easily transferred to large scale processing under microwave dielectric heating with continuous flow processing is investigated herein. This study sets out to prove if it is feasible to directly transfer reaction parameters from one platform to another and to scale-up reactions efficiently and reliably using different (microwave and conventional) heating technology. This idea will be tested using a well-known transformation, the Bohlmann-Rahtz pyridine synthesis, which works very well under both conventional and microwave batch heating conditions. A range of different microwave batch and flow technologies, as well as conventional heating platforms, will be tested and compared to establish how readily reaction parameters transfer from one instrument to another. Further investigation will then be conducted on other, more complex, transformations, such as pyrimidine formation and the Hantzsch dihydropyridine synthesis.

2.1.1 A model reaction for the synthesis of pyridines

The pyridine ring plays a key role in several biological processes, most notably in the action of the oxidation/reduction coenzyme nicotinic adenine dinucleotide (NADP); the vitamin Niacin (or the corresponding acid) is required for its biosynthesis. Pyridoxine (vitamin B6) plays a key role as the coenzyme for transaminases. Nicotine, a highly toxic alkaloid, is the major active component in tobacco, and the most addictive drug known. Many synthetic pyridine derivatives are important as therapeutic agents, for example Isoniazide is a major antituberculosis agent and Sulphapyridine is one of the sulfonamide antibacterials (Figure 22).⁹⁹

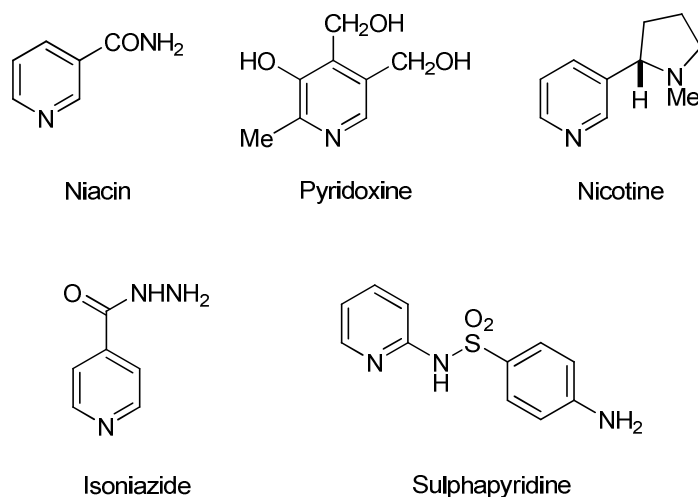
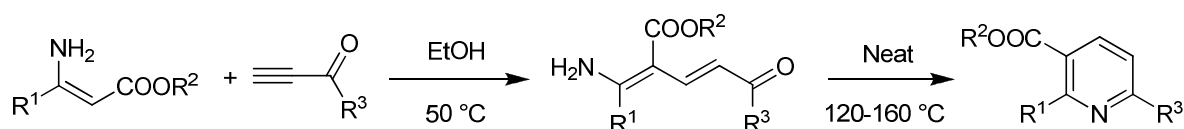

Figure 22. Presence of pyridine ring in natural molecules⁹⁹

Over the years, different synthetic procedures have been optimized for quick and efficient synthesis of pyridine and its derivatives. The Bohlmann-Rahtz (B–R) reaction¹⁰⁰ is one of the methodologies used nowadays for the formation of trisubstituted pyridines (Scheme 73). Firstly reported in 1957, this regioselective synthesis of trisubstituted pyridines proceeds by the reaction of enamines and alkynyl ketones or aldehydes. It is a two-step process that initially goes by Michael addition to give an aminodienone intermediate which can be isolated in high yield. In a subsequent step, the aminodienone intermediate undergoes cyclodehydration at a temperature of 120–160 °C, to give 2,3,6-trisubstituted pyridines in excellent overall yield and with total regiocontrol.



Scheme 73. Bohlmann-Rahtz pyridine synthesis

This transformation has been applied in the synthesis of pyridine-containing thiopeptide antibiotics and their derivatives, as well as pyrido[2,3-*d*]pyrimidines, heterocyclic amino acids, nonsteroidal anti-inflammatory agents, and combinatorial pyridine libraries.¹⁰¹

The Bohlmann-Rahtz cyclodehydration of aminodienones to access the target pyridine (Scheme 73) represents a relatively simple transformation but one that requires high temperatures and as such should be ideal for our study. It can be carried out under homogenous conditions involving just one reagent and this facility should enable a simple comparison of reaction efficiency to establish the performance of different reaction platforms.

2.1.2 Comparing Different Platforms for the Bohlmann-Rahtz Cyclodehydration Reaction

Aminodienones were synthesized by condensation of the alkynone **27** and enamine **28** in ethanol under conductive heating following the general strategy shown in Scheme 74. Non-commercially available alkynones were obtained in two steps: the aldehyde was reacted with ethynyl magnesium bromide affording the propargylic alcohol which was then oxidized to the corresponding ketone using IBX.

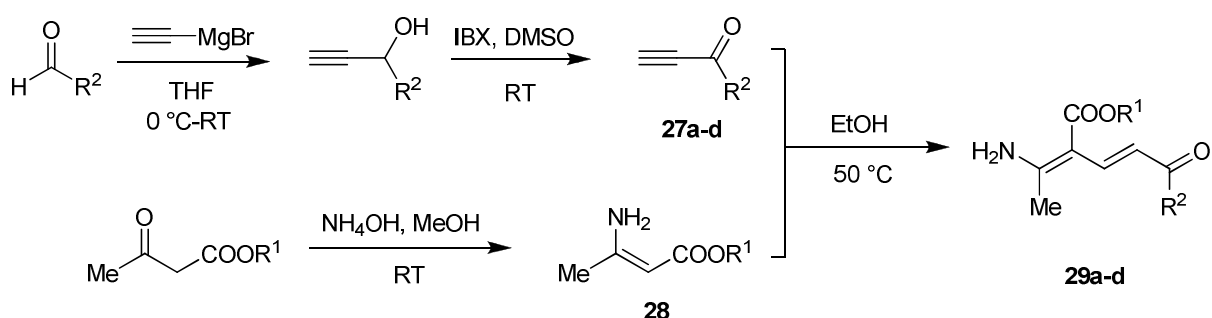

Scheme 74. General process for the synthesis of aminodienones

Feasibility Study in a Single-Mode Microwave Batch Reactor

Prior to optimization studies under continuous flow processing, a series of cyclodehydration experiments were carried out on aminodienone **29a** (R¹ = Et, R² = Ph) in batch mode using microwave dielectric heating (Table 2). The aim of these studies was to establish the optimum solvent and confirm reaction homogeneity under the reaction conditions in order to readily transfer the model reaction from batch to flow mode. Also, finding the shortest reaction time in batch (without affecting the reaction conversion) would ensure a short residence time as well as a shorter processing time.

Table 2. Microwave-assisted cyclodehydration of aminodienone **29a** ($R^1 = \text{Et}$, $R^2 = \text{Ph}$) in batch experiments to find an appropriate reaction solvent^a

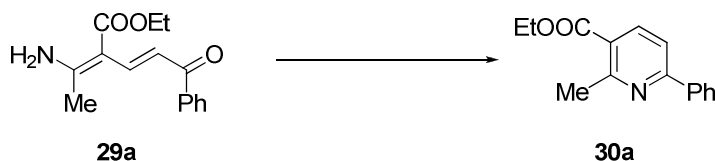

Entry	Solvent	Temperature [°C]	Time [Min]	Yield [%] ^b
1 ^d	EtOH	130	40	– ^c
2 ^d	DMSO	170	20	98
3 ^d	PhMe–AcOH (5:1)	50	20	>98
4 ^d	PhMe–AcOH (5:1)	70	10	>98
5	PhMe–AcOH (5:1)	100	2	>98

^a A solution of aminodienone **29a** (1 mmol) in the chosen solvent was reacted at the selected temperature, using a monomodal CEM Discover instrument, operating at an initial power of 150 W (which was modulated to maintain a constant reaction temperature); ^b Isolated yield of pyridine **30a** after aqueous work-up; ^c A mixture of **29a** and **30a** (2:1) was obtained; ^d Experiment was carried out by Caterina M. Lubinu.

Previous studies within the Bagley group have shown that the Bohlmann-Rahtz cyclodehydration proceeds at elevated temperatures in DMSO,¹⁰² alcoholic solvents¹⁰³ and toluene–acetic acid¹⁰⁴ and so these solvents were reviewed in the microwave batch experiments. Of these, the Brønsted acid-catalyzed procedure (Table 2, entry 3) was established as the most promising for optimization under a flow regime, giving pyridine **30a** in quantitative yield upon 20 minutes irradiation at a temperature of only 50 °C. Increasing the temperature to 70 °C (entry 4) or 100 °C (entry 5) did not compromise the efficiency of the process and in the latter case reduced the reaction time to only 2 min; thus this method was considered suitable for transfer to a microreactor for further investigation. The reaction conducted in EtOH (entry 1) and in DMSO (entry 2) were both problematic: the first, after 40 minutes at 130 °C, provided a mixture of starting material and product. The reaction in entry 2, after 20 minutes at 170 °C, did provide the desired pyridine in a quantitative yield (98%) but it was not possible to reduce the temperature further due to incomplete conversion.

Scale-Up in a Multimode Microwave Batch Reactor

Scale-up of the cyclodehydration reaction was then investigated in a sealed vessel under microwave-assisted conditions using the multimodal MILESTONE BatchSynthTM reactor.⁸⁹

Starting with aminodienone **29a**, a 0.1 M solution in toluene-acetic acid was irradiated for 2 min at 100 °C (modulating the initial power of 150 W to maintain constant temperature) using two different vessel sizes (60 and 100 mL) and volumes (Table 3) in order to explore any differences in heating efficiencies on increasing scale. On relatively small scale (1.9 mmol of **29a** in 19 mL solvent in a 60 mL vessel), the multimode instrument was found to perform well, giving efficient conversion to the corresponding pyridine **30a** (96% yield, Table 3, entry 1). However, on larger scale (7.7 mmol of **29a** in 75 mL solvent in a 100 mL vessel) a significant reduction in the yield of product was observed (65% yield, entry 2). When similar conditions were investigated in the 60 mL vessel for two further substrates **29b** and **29c** the yield of the corresponding pyridine **30b** and **30c** was found to vary (entries 3-5). These variations were attributed to temperature and reactivity differences and, in the comparison of reactions run in different vessels (entries 1 and 2), problems with the penetration depth of microwave irradiation could have led to irregularities in heating (possibly due to hot spots formation in the microwave cavity).¹⁰⁵ It was clear that a more reliable and robust method was required for the scale-up of this microwave-assisted reaction using this instrumentation.

Table 3. Microwave-assisted cyclodehydration of aminodienones **29a-c** in a multimode batch reactor.^a

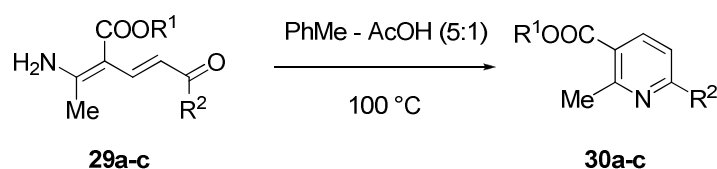

Entry	Substrate	R ¹	R ²	29 [mmol]	Yield[%] ^b
1	29a	Et	Ph	1.9	96
2	29a	Et	Ph	7.7	65
3	29b	Et	<i>p</i> -C ₆ H ₄ Cl	1.7	78
4	29c	Et	Me	0.9	87
5	29c	Et	Me	3.8	93

^a A solution of aminodienone **29a-c** (1.9 mmol) in PhMe–AcOH (5:1) was heated under microwave irradiation in a pressure rated Teflon vessel (60 or 100 mL) at 100 °C for 2 min using a multimodal MILESTONE BatchSynthTM instrument, operating at an initial power of 150 W (which was modulated to maintain a constant reaction temperature); ^b Isolated yield of pyridine **30** after aqueous work-up.

Scale-up: Continuous Processing using a Microreactor

The use of conductive heating continuous flow reactor platforms offers a viable alternative for the scale-up of microwave-assisted transformations carried out in batch mode.¹⁰⁶ To explore this opportunity, the cyclodehydration of aminodienones **29a-d** was carried out in a 250 μL Syrris AFRICA[®] microreactor (id: 60 μm) (see Introduction, paragraph 1.3.3) fitted with a pressurization module, single reagent feed and injection module, conductive heating chip reactor and product collection module. For a valid comparison with the microwave batch experiments, a 0.1 M stock solution of each aminodienone **29a-d** in toluene–acetic acid in turn was processed through the chip reactor at a temperature of 100 °C, varying the flow rate and thus the residence time (Table 4). However, the cyclodehydration of aminodienone **29c** at this concentration resulted in the precipitation of pyridine **30c**, thus blocking the line, and so for this substrate the experiments were performed at a concentration of 0.05 M (entry 4). In each experiment, the outflow was sampled using GCMS and the analysis was further complemented by ¹H NMR spectroscopic studies following aqueous extraction, once sufficient outflow was collected. For all four substrates **29a-d**, a residence time of 1 or 2 min (entry 1) gave incomplete conversion to the corresponding pyridine **30a-d**, whereas residence times of 4 min resulted in complete (>98%) conversions (entries 2-5). This discrepancy in residence time between the conductive heating microreactor platform and microwave batch experiment, whilst small, was considered to be significant and was attributed to a temperature differential across the walls of the microwave vessel, resulting in the recorded temperature, as measured by the instrument's IR sensor at the outer wall, being lower than the internal reaction temperature. This was noted as a point of caution in the transfer of parameters between microwave and conductive heating platforms and was observed for the reactions conducted in the UNIQUISIS system too (see later).

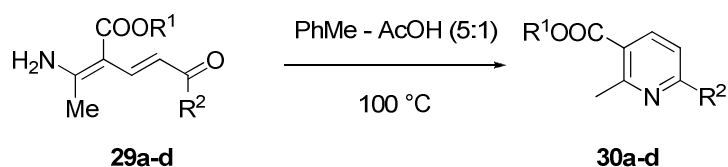
Table 4. Cyclodehydration of aminodienones **29a-d** in a microreactor^a

Entry	Substrate	R ¹	R ²	Residence time [min]	Conversion [%] ^b
1	29a-d			2	– ^c
2	29a	Et	Ph	4	>98
3	29b	Et	<i>p</i> -C ₆ H ₄ Cl	4	>98
4 ^d	29c	Et	Me	4	>98
5	29d	<i>t</i> -Bu	Me	4	>98

^a Reactions were carried out using a 0.1 M solution of the corresponding aminodienone **29a-d** in PhMe–AcOH (5:1) using a 250 μL Syrris AFRICA[®] microreactor at 100 °C for the indicated residence time; Reactions were carried out by Caterina M. Lubinu; ^b Conversion from aminodienone **29** to the corresponding pyridine **30** was established by GCMS and ¹H NMR spectroscopy after aqueous work-up; ^c A mixture of **29** and **30** (3:1) was obtained; ^d A 0.05 M solution of **29c** was used.

Scale-Up: Continuous Processing using a Stainless Steel Conductive Heating Flow Reactor

Another conductive heating flow reactor available for scale-up is the UNIQUISIS FlowSyn™ conductive heating platform, whose characteristics have been previously described (see Introduction, paragraph 1.3.3). For this study, 0.1 M solutions of aminodienones **29a-c** were processed at 100 °C using a 5 mL stainless steel coil (id: 1000 μm) for 2 min (Table 5), in order to establish if this residence time would lead to efficient conversion to the respective pyridine **30a-c**, in accordance with the corresponding microwave-assisted process. Although the processing rate for this apparatus was reasonably high, the isolated yield of pyridine **30a**, **30b** and **30c** was compromised (62, 52 and 25% respectively) due to incomplete conversion. It was felt the reduction in efficiency was due to differences in how the temperature was measured between the conductive heating coil and microwave-heated reactors; in fact parameters for the stainless steel flow reactor had transferred successfully from the corresponding microreactor (Syrris Africa[®]), which was also less efficient at 2 min residence time.

Table 5. Continuous processing of pyridines **30a-c** in a stainless steel conductive heating flow reactor^a

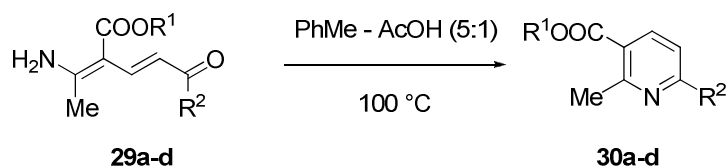

Entry	Substrate	R ¹	R ²	Residence time ^b [min]	Processing rate ^c [mmol min ⁻¹]	Yield [%] ^d
1	29a	Et	Ph	2	0.25	62
2	29a	Et	Ph	2	0.25	66
3	29b	Et	<i>p</i> -C ₆ H ₄ Cl	2	0.25	52
4	29c	Et	Me	2	0.25	25

^a Reactions were carried out using a 0.1 M solution of **29** in PhMe–AcOH (5:1) in a stainless steel heating coil (5 mL) with a UNIQUIS FlowSyn™ operating at a flow rate of 2.5 mL min⁻¹; ^b Time of residence in the heated stainless steel reactor coil; ^c Rate of processing aminodienone **29** through the reactor, during continuous operation; ^d Isolated yield of pyridine **30** after aqueous work-up.

Scale-Up in a 10 mL Glass Flow Reactor

In order to investigate if improved processing rates could be obtained by continuous flow processing, 0.1 M solutions of aminodienones **29a-d** in toluene–acetic acid were irradiated at 100 °C for 2 min under continuous flow processing, using our 10 mL flow cell apparatus described previously (see Introduction, paragraph 1.3.3),⁸⁷ and the results compared to microwave batch experiments using the same single-mode cavity. The flow cell was filled with sand, to help prevent back-mixing, and stabilized at 100 °C with eluent at a flow rate of 1.5 mL min⁻¹ using an initial microwave power of 200 W. Each substrate was then passed through the flow cell in turn and discharged with further portions of eluent into an aqueous base quench. In all cases, the process was found to give an excellent yield of the corresponding pyridine **30a-d** (Table 6), with some experiments (entries 3 and 4) showing improved performance over the comparable microwave batch reaction (96 to 98% compared to the 80-82% batch yield). This was rationalized by small but significant differences in the reaction temperature when carrying out experiments under batch and flow conditions, with the flow cell anticipated being at a higher internal temperature in order to produce the same temperature reading on the outer glass wall. Using this flow cell, it was evident that

parameters for batch microwave reactions could be transferred readily to continuous flow processing, which represented a robust and efficient means to scale-up a microwave reaction.

Table 6. Comparison of continuous processing of pyridines **30a-d** in a single-mode 10 mL glass flow microwave reactor and the corresponding microwave batch reaction in a sealed tube.^a

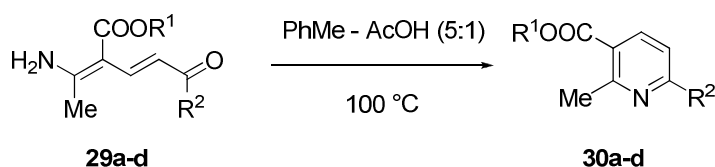

Entry	Substrate	R ¹	R ²	Batch yield [%] ^b	Flow cell yield [%] ^c
1	29a	Et	Ph	>98	>98
2	29b	Et	<i>p</i> -C ₆ H ₄ Cl	98	>98
3	29c	Et	Me	80	96
4 ^d	29d	<i>t</i> -Bu	Me	82	98

^a The reaction of each aminodienone **29a-d** (0.3 mmol) in PhMe–AcOH (5:1) was carried out under microwave irradiation at 100 °C for 2 min using a CEM Discover[®] single-mode microwave synthesizer, operating at 200 W (initial power) which was modulated to maintain a constant reaction temperature; ^b Isolated yield of pyridine **30** after irradiation at 100 °C (150 W) in a sealed tube for 2 min, cooling in a stream of compressed air and aqueous work up; ^c Isolated yield of pyridine **30** after aqueous work-up; ^d Experiment was carried out by Caterina M. Lubinu.

Scale-Up in a 80 mL Glass Flow Reactor

Considering the successful scale-up with the 10 mL flow cell apparatus, it was decided to test further the heteroannulation reaction with an 80 mL flow cell apparatus. The same procedure as for the 10 mL flow cell apparatus was used to carry out the reactions. To that end, 0.1 M solutions of aminodienones **29a-c** in toluene–acetic acid were irradiated at 100 °C for 2 min under continuous flow processing and the results compared to microwave batch experiments and to the 10 mL flow cell experiments using the same single-mode cavity. With this set up, the desired pyridines **30a-c** were obtained in excellent yield (Table 7), with improved performance compared to the batch experiments. Compared to the 10 mL flow cell experiments, the yields were similar but in one case (entry 3) there was a slight decrease in the performance of the scale-up system (85% compared to 96%), probably due to loss of

material during work-up. Overall, the 80 mL flow reactor proved highly reliable for the scale-up to gram scale of a microwave-mediated process, with the advantage of higher flow rates for a faster processing.

Table 7. Comparison of continuous processing of pyridines **30a-c** in two single-mode glass microwave flow reactors and the corresponding microwave batch reaction in a sealed tube.^a

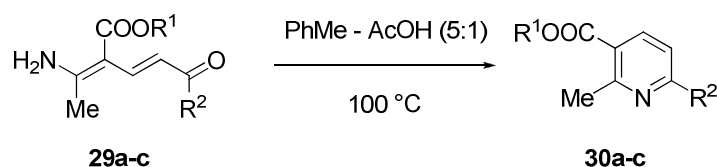

Entry	Substrate	R ¹	R ²	Batch yield [%] ^b	10 mL	80 mL
					Flow cell Yield [%]	Flow cell Yield [%] ^c
1	29a	Et	Ph	>98	>98	>98
2 ^d	29b	Et	<i>p</i> -C ₆ H ₄ Cl	98	>98	>97
3	29c	Et	Me	80	96	85

^a The reaction of each aminodienone **29a-c** (1 mmol) in PhMe–AcOH (5:1) was carried out under microwave irradiation at 100 °C for 2 min using a CEM Discover[®] single-mode microwave synthesizer, operating at 200 W (initial power) which was modulated to maintain a constant reaction temperature; ^b Isolated yield of pyridine **30** after irradiation at 100 °C (150 W) in a sealed tube for 2 min, cooling in a stream of compressed air and aqueous work up; ^c Isolated yield of pyridine **30** after aqueous work-up; ^d Reaction carried out with 1.2 mmol of aminodienone **29b** in PhMe–AcOH (12 mL, 5:1) at a flow rate of 6 mL/min.

Scale-Up: Continuous Processing under Microwave Heating using a Stop-Flow Single-Mode Reactor

A different method to carry out microwave-assisted reactions on preparative scale is provided by the CEM Voyager[®] platform, stop-flow single-mode reactor.¹⁰⁷ This platform makes use of the same 80 mL Pyrex tube and fiber optic system used for the 80 mL flow cell studies previously conducted, even if, for the CEM Voyager[®], the 80 mL tube is empty at the beginning of the reaction. The tube is subsequently filled by an automatic process carried out by the pump (as shown in Figure 23); the reaction is then started automatically. Nevertheless, an immediate comparison of results was possible.

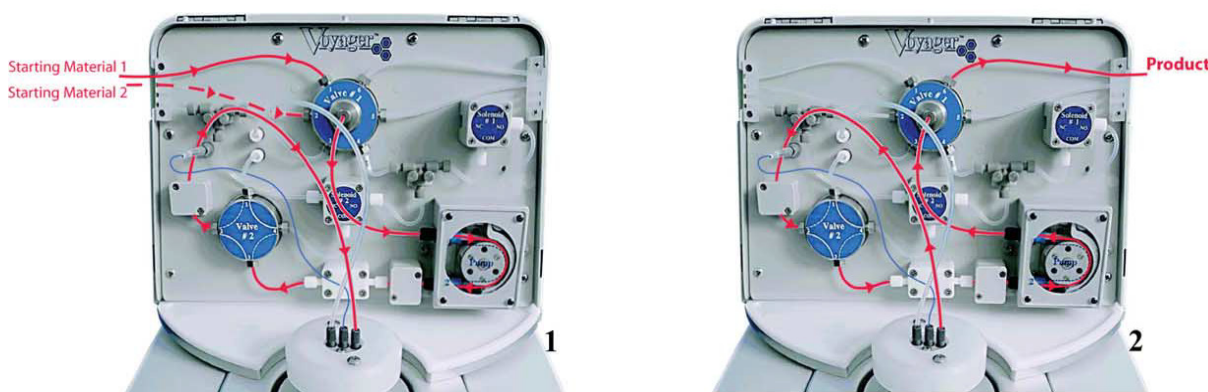
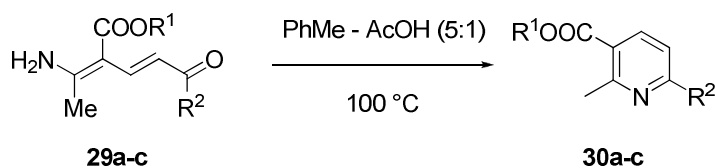

Figure 23. Addition and removal step in the CEM Voyager[®] reactor^{107a}

The Bohlmann-Rahtz cyclodehydration was performed on this platform enabling pyridines **30a-c** to be processed in good yield (Table 8). All reactions were carried out at 0.1 M concentration apart from aminodienone **29b** (entry 2), which was processed at 0.05 M concentration in order to prevent any problems with product precipitation blocking the line.^{107d} Under these conditions, the apparatus was found to be reliable for all of the substrates investigated, with isolated yields varying between 83% (**30c**) and 94% (**30a**). Stop-flow operation facilitated the ready transfer of parameters directly from batch-mode to continuous processing for this microwave-assisted transformation and so could offer a highly effective and alternative method for scaling-out production,^{107c, 107e, 108} although overall the processing rates were not very high.

Table 8. Continuous processing of pyridines **30a-c** in a stop-flow single-mode microwave reactor.^a



Entry	Substrate	R ¹	R ²	29 [mmol]	Residence time ^b [min]	Yield [%] ^c
1	29a	Et	Ph	2.0	2	90
2	29b	Et	<i>p</i> -C ₆ H ₄ Cl	0.9	2	94
3	29c	Et	Me	2.0	2	83

^a The reaction of each aminodienone **29a-c** (2 mmol) in PhMe–AcOH (5:1) was carried out under microwave irradiation at 100 °C for 2 min using a CEM Voyager[®] platform on the Discover[®] single-mode microwave synthesizer, operating at an initial power of 150 W (which was modulated to maintain a constant reaction temperature); ^b Hold time at 100 °C under microwave irradiation; ^c Isolated yield of pyridine **30** after aqueous work-up.

Mesoscale Continuous Processing under Microwave Heating

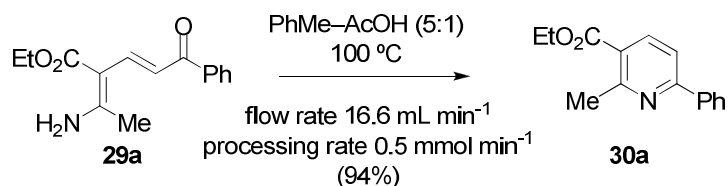

Scheme 75. Mesoscale production of pyridine **30a** using a continuous flow microwave reactor

Finally, given the success of the microwave flow reactions in providing efficient conversion to the corresponding pyridines, efforts were made to improve the processing rate and transfer the established parameters to mesoscale production under continuous flow processing. For this purpose, a multimode Milestone BatchSynthTM microwave synthesizer was operated under continuous flow processing using the FlowSynthTM platform (see Introduction, paragraph 1.3.3). A solution (0.047 M) of aminodienone **29a** (30.5 mmol, 7.9 g) in toluene-acetic acid (650 mL, 5:1), diluted so as to avoid any problems of product precipitation, was passed through the microwave cavity at a flow rate of 16.6 mL min⁻¹ (1 L h⁻¹) and heated to 100 °C under microwave irradiation using an initial power of 150 W (Scheme 75). At this flow rate, the residence time would be substantially longer (~12.5 min) but it was thought that this would account for field and temperature inhomogeneities and would still deliver improved production. After aqueous work up, pyridine **30a** was isolated in 94% yield. Even with the increased dilution and longer residence time, this represented a substrate processing rate of 0.5 mmol min⁻¹, which was significantly higher than any other platform investigated in this study. This scale-up solution would be ideal for large scale production at industrial level, even if preliminary studies would be required to effectively carry out the desired transformations.

Feasibility Study: the 2-in-1 step Bohlmann-Rahtz pyridine synthesis using a range of instruments

Previous work within the group aimed to establish a more direct route to 2,3,6-trisubstituted pyridines by combining both steps of the Bohlmann-Rahtz pyridine synthesis into a single procedure in both batch and flow mode.² The best conditions to carry out this reaction used a mixture of ethanol/acetic acid (5:1) at 120 °C but further investigation was still required to prove the feasibility of this methodology on scale-up using a diverse range of instrumentation. For this reason the reaction between alkynone **27a** and enamine **28** was repeated in batch

mode and then further examined using some of the instrument platforms previously investigated (Table 9).

Table 9. Bohlmann-Rahtz pyridine synthesis using different instruments^a

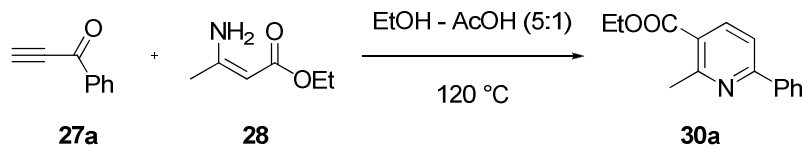

Entry	Instrument	Residence time [min]	Flow rate [mL min ⁻¹]	Temperature [°C]	Yield [%] ^b
1	CEM Discover	5	-	140	78
2	CEM Discover	5	-	150	97
3	CF 10 mL	5	0.6	120	76
4 ^c	BatchSynth	5	-	120	32
5 ^c	BatchSynth	2.5	-	120	28
6 ^d	UNIQUIS	5	4	120	71
7 ^e	UNIQUIS	5	1	120	86

^a Reactions were performed using 1 equiv of **27a** and 1.3 equiv of **28** in EtOH-AcOH (5:1) at the given temperature (120 °C) and initial power (90 W) unless otherwise stated; ^b All the products were contaminated by unidentified by-products (apart from entries 1, 3, 4 and 5); ^c Reaction was carried out at 200 W initial power; ^d 20 mL coil used; ^e 5 mL coil used.

Repetition of the batch experiment for 5 min at 140 °C (90 W) (entry 1) gave a comparable yield to previous examples but a slight increase in the temperature (150 °C instead of 120 °C, entry 2) gave an improved yield, even if the formation of impurities was observed. The reaction was then conducted in the 10 mL flow cell apparatus: a processing rate of 0.6 mL/min was chosen, keeping the reaction temperature at 120 °C (entry 3). Formation of the product was still observed, in comparable yield (76% compared to 78% in batch), showing that it was possible to perform this transformation in continuous flow mode. The reaction was then investigated using the Milestone BatchSynth™ instrumentation, in the 60 mL vessel: different reaction times were employed. Initially the reaction was heated for 5 min (entry 4) and this provided the desired product in poor yield (32%) after purification by column chromatography. An almost identical result was obtained by reducing the reaction time to 2.5 min (entry 5): the product was obtained in 28% isolated yield after purification. This was evidence that the system required further investigation in order to be adapted for scale-up with this instrumentation. Finally, the transformation was tested using the conventional heating

UNIQUISIS platform (entry 6 and 7). At flow rates of 4 mL min⁻¹ and 1 mL min⁻¹ two separate experiments gave the product in 71% and 86% yield (with the presence of inseparable by-products) using two different sizes of coils (20 mL and 5 mL, respectively).

2.1.3 Conclusions

The Bohlmann-Rahtz cyclodehydration reaction was transferred and performed in a range of flow-chemistry equipment retaining excellent and comparable yields to batch instrumentation. Direct comparison of monomode and multimode microwave batch reactions (Table 2 and 3) showed that the transfer of reaction parameters from monomode to multimode instrumentation would require further investigation to achieve the same order of results. This was probably due to the different way temperature was measured, as inhomogeneous heating would affect the outcome of the scale-up (Table 3, entry 2). On a different angle, conventional heating devices tested herein (Syrris Africa[®] and Uniqsis FlowSyn[™], Table 4 and 5) required further adjustments to achieve the same level of results as microwave-mediated batch reactions. Also, from a comparison of the results obtained using the two instruments it could be seen that the microreactor based Syrris Africa[®] gave better results in terms of yield than the coil based Uniqsis FlowSyn[™]. This was probably due to the advantages of micromixing and temperature/mass transfer that a microreactor is able to achieve with the smaller diameter of its channels (id: 60 μm), compared to the larger diameter of a mesoreactor like a coil use in the Uniqsis system (id: 1000 μm) but it has to be said that the reactions in the Syrris Africa[®] instrument were run using a residence time that was two times the one that was employed on the Uniqsis system. Then, for a direct comparison of the results, the experiments with the Uniqsis instrument have to be repeated using the same residence time as the Syrris Africa[®]. This has been planned as future work and, probably, the same order of results could be obtained. Moving to microwave flow instrumentation, the 10 mL flow apparatus proved extremely reliable in transferring reaction parameters from microwave batch to flow (Table 6), with further achievements obtained using the larger 80 mL flow cell apparatus (Table 7). This last one proved very efficient compared to stop-flow instrumentation (Table 8) and multimode microwave flow instrumentation (Scheme 75), even if the multimode flow could represent a better solution for industrial needs. The 2-in-1 step Bohlmann-Rahtz pyridine synthesis on the other hand proved a tricky transformation to be transferred to continuous flow mode, compared to the Bohlmann-Rahtz cyclodehydration reaction, with poor results

obtained in monomode continuous flow and multimode batch-mode alike. Further investigation would be necessary for reliable transfer between different instrumentation. Overall, the Bohlmann-Rahtz cyclodehydration reaction as a test reaction proved that it is possible to transfer reaction parameters efficiently between microwave monomode and microwave multimode instruments and from batch to flow mode without significant loss in reaction performance.

2.2 Synthesis of pyrimidines

2.2.1 Introduction

As part of DNA and RNA and as core components of vitamin B2 and folic acid, pyrimidine derivatives have considerable biological importance. This class of compounds has been associated with various therapeutic areas including anti-HIV,¹⁰⁹ antineoplastic,¹¹⁰ and antimalaria¹¹¹ activities or for the treatment of cardiovascular disease.¹¹² One method for the synthesis of pyrimidines is the reaction of an alkynone and amidine nucleophile.¹¹³ It is likely that this reaction proceeds by 1,4-addition followed by cyclodehydration to yield the target 2,4,6-trisubstituted pyrimidine.

Previous work within the Bagley group showed that the cyclocondensation of an alkynone and amidine in acetonitrile in the presence of sodium carbonate as base (to liberate the amidine from the corresponding hydrochloride salt) proceeds in 2 h under conductive heating and in 40 min under microwave-assisted conditions (Scheme 76).¹¹⁴

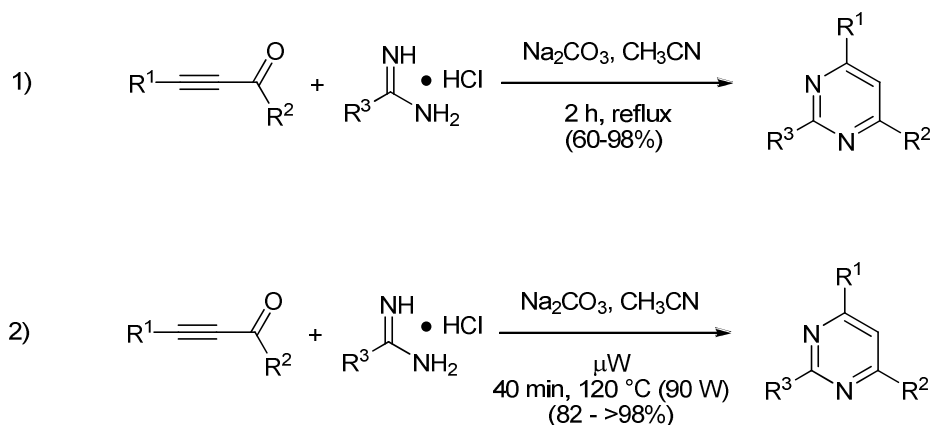

Scheme 76. Pyrimidine synthesis using alkynones as precursors at reflux (1) and under microwave irradiation (2)

The use of microwave irradiation reduced the reaction time from 2 h to 40 min and also resulted in improved yields without the need for chromatographic purification. Replacement of sodium carbonate with a stronger base such as sodium methoxide gave almost a quantitative yield in 20 min at 70 °C. Further investigation revealed that increasing the reaction temperature to 100 °C yielded the product quantitatively in just 2 min after a simple aqueous work up (Scheme 77).¹¹⁵

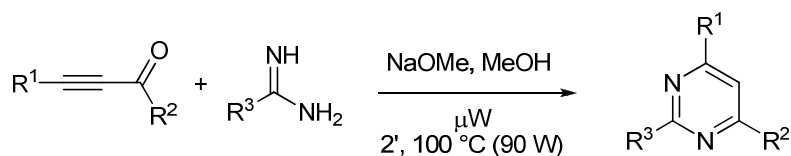

Scheme 77. Optimized methodology for the synthesis of 2,4,6-trisubstituted pyrimidines

In view of its very short reaction time, this tandem process was considered to be ideal to investigate the effect of a continuous flow system on the course of a heteroannulation reaction.

2.2.2 Results and Discussion

This new efficient procedure for the synthesis of pyrimidines from alkynones was described under microwave irradiation and was ready to be tested for scale-up using a range of instrumentation in a similar fashion as our experiments on pyridine synthesis, as reported in Table 10. In order to provide a homogeneous procedure for the rapid synthesis of pyrimidines appropriate for flow processing, a mixture of benzaldehyde hydrochloride **31a**•HCl (1.2 equiv) and sodium methoxide (1.3 equiv) was stirred in methanol at room temperature and filtered. Phenylpropynone **27a** (1 equiv) was added and the homogeneous solution was then heated in the selected instrument.

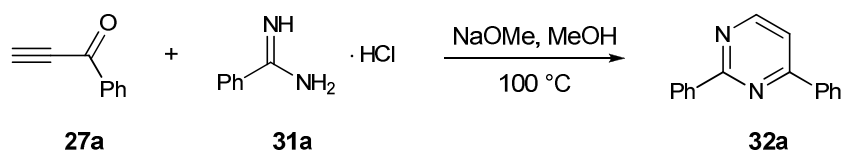
Table 10. Synthesis of 2,4-diphenylpyrimidines in a range of flow instrumentation^a

Entry	Instrumentation	Conditions ^b	27a [mmol] ^c	Product (yield [%]) ^d
1	Discover	2 min	0.52	32a 86
2	Discover CF 10 mL cell	2 min, 1.5 mL/min	0.52	32a 78
3	Discover CF 10 mL cell	2 min, 2.5 mL/min	1.04	32a 84
4	BatchSynth	2 min	3.84	27a, 31a, 32a^e
5	BatchSynth	5 min	3.84	27a, 31a, 32a^e
6	Voyager	2 min	5.2	32a 89
7	UNIQUISIS	7 min, 3 mL/min	6	32a 35

^a Reactions were performed using 1 equiv of **27a**, 1.2 equiv of **31a** and 1.3 equiv of NaOMe in MeOH at 100 °C (150 W as initial power); ^b Reaction time refers to hold time or to residence time in the flow cell; ^c The stoichiometry of the reaction was not changed; ^d Isolated yield of pyrimidine **32a** after aqueous work-up; ^e Mixture of starting materials and product (1:1:0.1) recovered at the end of the reaction (after ¹H NMR analysis of crude reaction mixture).

Initial reaction in the CEM Discover[®] synthesizer was performed at 100 °C for 2 min, giving the desired pyrimidine in 86% yield (Table 10, entry 1). Transfer of this protocol to the flow mode was done with the 10 mL flow cell setup used in a similar fashion for the studies on pyridine formation.

The system was initially flushed with methanol while it was taken to the desired temperature and then the reaction mixture was allowed to pass through the cavity at the desired flow rate. Initially it was decided to use a flow rate of 1.5 mL/min, corresponding to a residence time of 2 min and to a processing time of 35 min (entry 2). The desired product was isolated in 78% yield at the end of the process, a result comparable to the batch results. Increasing the flow rate to 2.5 mL/min (entry 3) corresponded to a slight increase in reaction productivity (84%). Scale-up of this process was also investigated in the multimodal microwave Milestone BatchSynth[™] reactor, used in batch mode with a 100 mL vessel. The reaction was initially carried out for 2 min, decreasing the initial power applied to the reaction vessel from 200 to 150 W (entry 4). However, after this experiment, only starting material with traces of product were found upon ¹H NMR spectroscopic analysis of the crude reaction mixture. Increasing the reaction time to 5 minutes (entry 5) did not give a different result. Scaling up the reaction in the stop-flow Voyager[®] instrument proved a valid alternative to the continuous flow

flow rate to 5 mL/min, corresponding to the same residence time as for the previous experiment. The desired product was obtained in a lower yield (71%) although the facility for the faster processing of material was considered to be an advantage. These results were compared with a comparable experiment using stop-flow processing in the CEM Voyager[®] apparatus to establish any advantages of a continuous flow processing regime. In this case, (entry 3) the compound was obtained in a lower yield (65%) compared to the 10 mL flow cell (90%) and to the 80 mL flow cell under continuous operation (71%); these results could be explained by inhomogeneities in temperature, both in terms of the actual operating temperature and the temperature profile when heating and cooling cycles are considered (in particular for the stop-flow system). Moving to the multimodal microwave apparatus, comparable results to the 10 mL flow cell were obtained (85%, entry 4) and further scale-up did not correspond to any loss in yield (86%, entry 5), making this system an extremely reliable and alternative way to scale-up the mmol continuous flow process for this reaction. Finally, the reaction was investigated using the conductive heating UNIQUISIS flow reactor platform (Table 11, entry 6). In this case the transformation was conducted for 5 minutes at a flow rate of 2.5 mL/min, obtaining the desired pyrimidine in a lower yield (77%) compared to the 10 mL flow cell set up (entry 1). An explanation of this observation could be provided by considering the differences in temperature measurement between the conventional heating system and the microwave instrumentation, corresponding to non-homogeneous heating in the microwave system and respective increase in product yield (through being carried out at a higher actual reaction temperature). This hypothesis, although reasonable given the data, was not tested with further experimentation.

2.2.3 Conclusions

The scale-up of the synthesis of selected pyrimidines has been successfully carried out in an efficient and reliable way under microwave irradiation. In the case of 2,4-diphenylpyrimidine (**32a**) synthesis, the reaction parameters were readily transferred between microwave batch and 10 mL flow instrumentation but it was not possible to obtain good results in the case of multimode microwave instruments. On the other hand, stop-flow instrumentation proved reliable for the scale-up of this transformation, obtaining comparable results to the microwave batch experiments and suggesting that similar results could be achieved using the 80 mL flow cell apparatus. The conventional heating device was not successful for the transfer of reaction parameters, requiring longer reaction times to afford a smaller amount of product. For the 2-

aminopyrimidine product **32b**, the desired compound was obtained in a good to a very good range of yields (65 to 90%), with the 10 mL continuous flow cell and multimode batch instrumentation giving comparable results. On a different angle, the same amount of starting material was processed in the 80 mL continuous flow cell compared to the multimode microwave batch instrumentation, with the advantage of the continuous flow processing for the former, even if there was a slight decrease in yield for the 80 mL flow cell apparatus. The 80 mL flow cell was also more reliable compared to the stop-flow instrumentation in terms of reaction yields. A conventional heating instrument (Uniqsis Flowsyn) did not give similar results compared to microwave batch and flow instrumentation in terms of reaction time and productivity (77% of **32b** in 5 min residence time using the Uniqsis instrument compared to 90% in 2 min residence time using the 10 mL flow cell setup), requiring an additional adjustment of reaction parameters to achieve comparable results.

2.3 Hantzsch Dihydropyridine Synthesis

2.3.1 Introduction

The Hantzsch dihydropyridine synthesis is a four component condensation reaction, that generates 1,4-dihydropyridine-3,5-dicarboxylate (1,4-DHP) derivatives **35** by condensation of an aldehyde **33**, β -keto ester **34** and ammonia (Scheme 78).

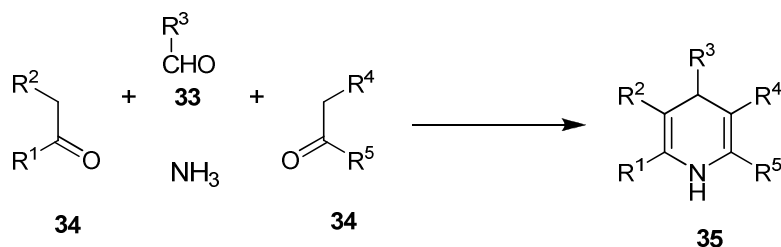

Scheme 78. Hantzsch four-component condensation reaction

First reported in 1881,¹¹⁶ this multicomponent condensation reaction represents an important pathway to access 1,4-DHP derivatives with valuable pharmacological activity.¹¹⁷ The 1,4-

DHP motif is found in a number of chemotherapeutic agents for the treatment of cardiovascular disease such as hypertension and angina pectoris.¹¹⁸

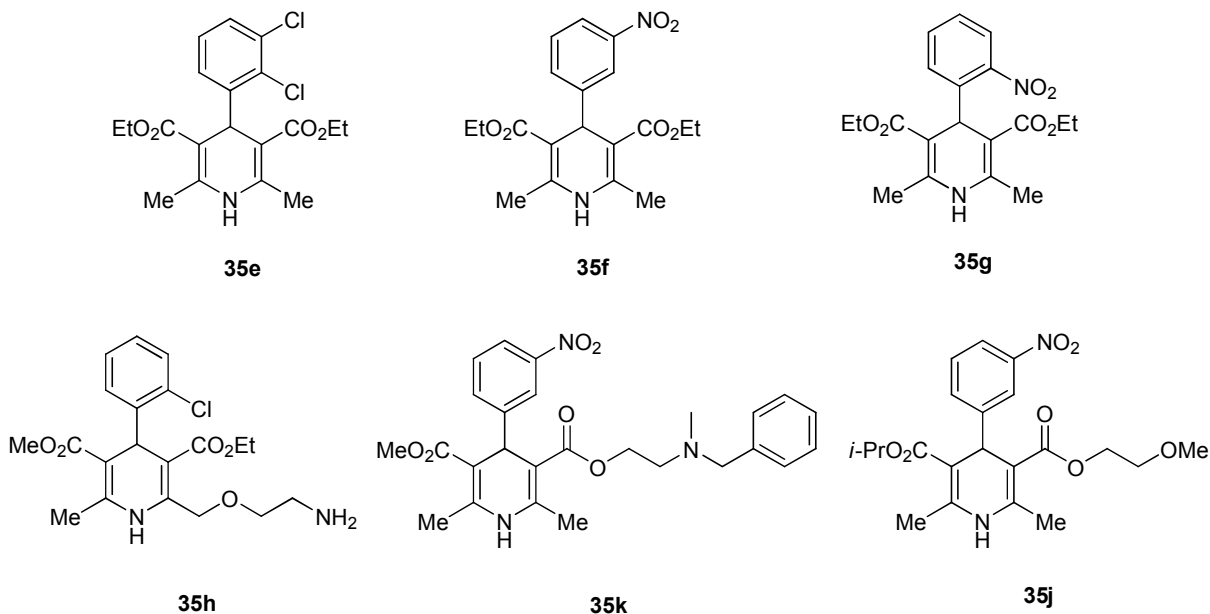

Scheme 79. Examples of dihydropyridines with chemotherapeutic activity¹¹⁷

Examples of commercial 1,4-DHP derivatives with chemotherapeutic activity include the 4-(2-chlorophenyl) derivatives Felodipine **35e** and Amlodipine **35h**, 4-(2-nitrophenyl) DHP derivative Nifedipine **35g** and 4-(3-nitrophenyl) derivatives Nitrendipine **35f**, Nicardipine **35k** and Nimodipine **35j**, amongst others (Scheme 79).¹¹⁷ This important class of calcium channel antagonists has been proven to act by decreasing the passage of the transmembrane calcium current on binding, causing a long lasting relaxation in smooth muscle and reduction of contractility throughout the cardiac muscle.¹¹⁹

Previous work within the group addressed the rapid synthesis of this class of compounds under microwave irradiation. Using the Öhberg and Westman conditions (Scheme 80),¹²⁰ a range of pure 1,4-DHP derivatives were synthesized in poor to good yields (21 to 68%).

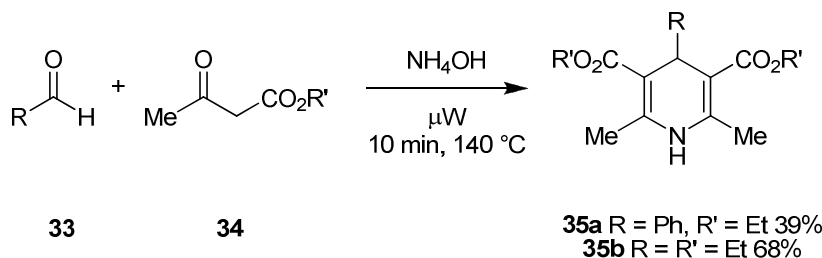

Scheme 80. Microwave-assisted synthesis of 1,4-DHP **35**

After optimization of the reaction conditions, aimed at transferring the batch conditions to a continuous processing mode, it was found that TMS-propargyl aldehyde **33c** and

phenylpropargyl aldehyde **33d** reacted very efficiently under microwave-assisted conditions to give the corresponding 1,4-DHPs **35c/d** (Scheme 81).

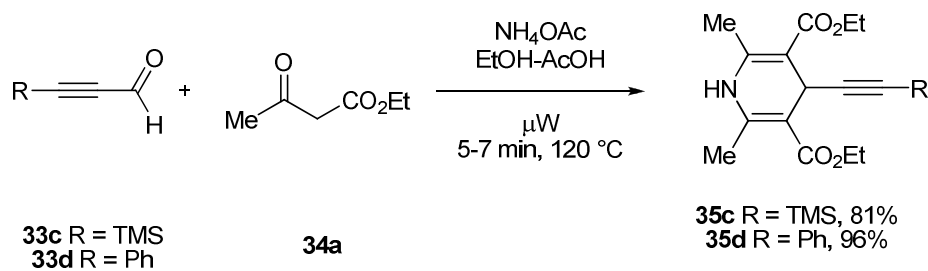

Scheme 81. Four-component Hantzsch dihydropyridine synthesis

It was noted that two different sets of conditions were used for the synthesis of two structurally different types of pyrimidines, so an investigation at batch scale was required to assess which one of the two methods was the most efficient in order to carry out this transformation.

2.3.2 Results and Discussion

Initially benzaldehyde **33a** and propionaldehyde **33b** were reacted according to Watanabe conditions:¹²¹ 1 equivalent of aldehyde and 5 equivalents of ethyl acetoacetate were reacted with 4 equivalents of aqueous ammonia using ethanol as solvent for 10 minutes at 140 °C in a standard microwave glass reactor, moderating the initial power of 150 W. The desired dihydropyridines **35a** and **35b** were obtained in 70 and 82% yields respectively (Table 12, entries 1 and 5). Then the same reaction was performed adding water to the mixture, as proposed by Leadbeater.¹²² A significant decrease in yield was observed: 41 and 67% yield for compounds **35a** and **35b** (entries 2 and 6). Changing the stoichiometry according to Leadbeater conditions (3.4 equiv. of **34a** instead of 5) corresponded to a significant loss in reaction conversion, with product **35a** obtained in 35% and product **35b** in a 46% yield (entries 3 and 7). By these studies it could be concluded that only the initial conditions with ethanol as solvent provided the best conversion. An investigation on the use of ammonium acetate instead of aqueous ammonia was then conducted in order to compare the efficiency of the two systems. The two aldehydes were then reacted using ammonium acetate in a mixture of acetic acid/ethanol as solvent but the results obtained were poor: the products **35a** and **35b**

Table 13. Continuous synthesis of dihydropyridines **35 a,b** in a stainless steel conductive heating flow reactor.^a

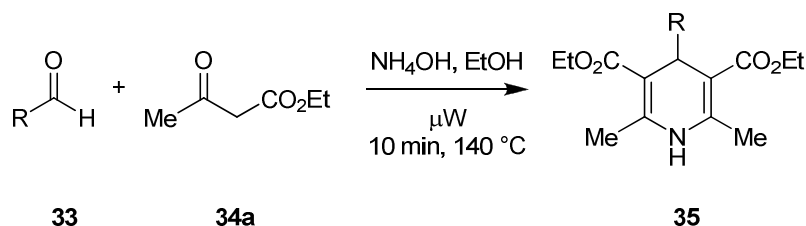

Entry	Substrate	R	Residence time ^b [min]	Processing rate ^c [mL min ⁻¹]	Temp. [°C]	Batch Yield [%]	Yield [%] ^d
1	33a	Ph	2	0.5	140	70	43
2	33a	Ph	2	0.17	120	70	35
3	33b	Et	2	0.5	140	82	68
4	33b	Et	2	0.17	120	82	34
5	33b	Et	2	0.67	140	82	39

^a Reactions were performed using 1 equiv of **33a/b** and 5 equiv of **34a** in EtOH (1.4 mL) at the given temperature (140 °C) in a stainless steel heating coil (5 mL) with a UNIQUISIS FlowSyn™ operating at the selected flow rate; ^b Time of residence in the heated stainless steel reactor coil; ^c Rate of processing solution through the reactor, during continuous operation; ^d Isolated yield of dihydropyridine **35** after aqueous work-up.

Initially a solution of aldehyde **33a**, ethyl acetoacetate **34a** and ammonium hydroxide in ethanol was reacted at 140 °C in a UNIQUISIS FlowSyn™ conductive heating platform at a processing rate of 0.5 mL/min, obtaining the corresponding dihydropyridine **35a** in poor yield (42%, entry 1) compared to the previous results from the optimization studies (Table 12, entry 1) but comparable in yield to the ones previously reported from previous members of the group (**35a** from Scheme 80). An attempt to optimize the reaction by lowering the reaction temperature (to 120 °C) did not provide improved results (entry 2). A solution of aldehyde **33b**, ethyl acetoacetate **34a** and ammonium hydroxide in ethanol was then reacted using the best reaction conditions found from the optimization studies previously reported (Table 12). The desired dihydropyridine **35b** was obtained in 68% yield (entry 3), a similar result compared to previously reported batch attempts (68%, **35b** in Scheme 80), but worse than the previous optimization studies (entry 1, Table 12). Attempts to further optimize the process by changing the reaction temperature (140 to 120 °C) and/or the processing rate (decreasing it to 0.17 mL/min, entry 4, or increasing to 0.67 mL/min, entry 5) did not provide higher conversions (34 and 39%, entry 4 and 5).

2.3.3 Conclusions

After comparing different approaches, reliable methodology for the formation of 1,4-dihydropyridines was established that makes use of ammonium hydroxide as nitrogen source and ethanol as solvent. This methodology has been applied to the synthesis of two 1,4-DHP derivatives in continuous flow mode, obtaining the desired products in reasonable yield. Some reduction in efficiency was observed in transferring from batch to continuous flow processing. This could be due to the different way that temperature is measured between the conductive heating coil and microwave-heated reaction platforms, suggesting that better results could be obtained by using microwave flow instrumentation, as the 10 mL and 80 mL flow devices have described the successful scale-up of other transformations (see Introduction, paragraph 1.3.3).

2.4 Application to natural product synthesis – attempted synthesis of Meridianins

2.4.1 Introduction

The conditions optimized previously for pyrimidine formation could be applied to the synthesis of the heterocyclic natural product Meridianin (**38**).

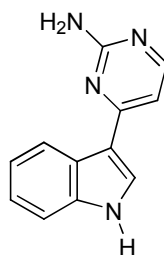
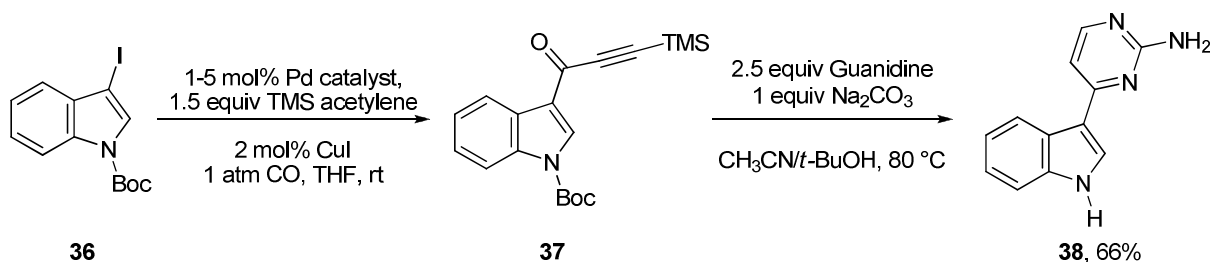

Figure 24. Meridianin **38**

This indole alkaloid with a 2-aminopyrimidyl substituent has been shown to inhibit a good number of protein kinases in a low micromolar range.¹²³ The alkaloid is structurally related to the variolin family, which display antitumor and antiviral activity. Meridianin was originally synthesized from Boc-protected 3-iodoindole using a carbonylative Sonogashira reaction

under an atmosphere of carbon monoxide, followed by reaction with guanidine to afford the pyrimidine moiety (Scheme 82):¹²⁴



Scheme 82. Karpov approach to Meridianin **38**

An alternative CO source, as reported in many examples in the literature, is molybdenum hexacarbonyl $[\text{Mo}(\text{CO})_6]$.¹²⁵ This compound avoids the difficult handling of gaseous CO and could be used in a microwave-promoted reaction. In the second step of the reaction scheme it would be possible to apply our microwave-accelerated conditions for pyrimidine synthesis as reported previously in paragraph 2.2 (Scheme 83) to provide a rapid and highly expedient route to the natural product:

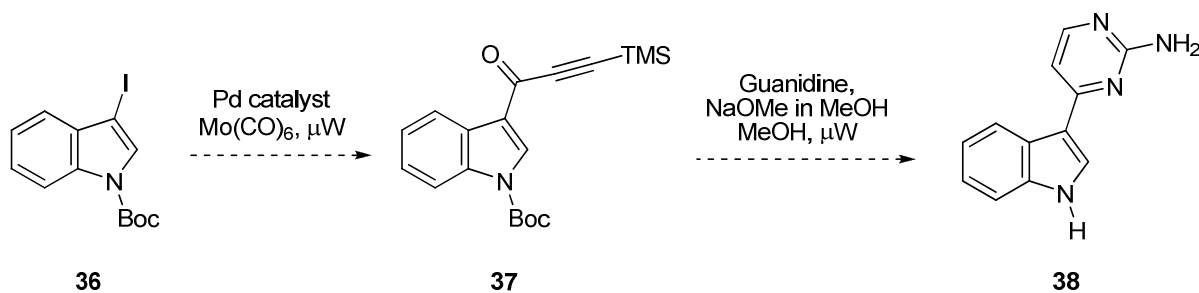

Scheme 83. Retrosynthetic approach to the synthesis of **38**

2.4.2 Results and Discussion

It was initially decided to validate the first step of the reaction by using a simple starting material, 4-iodoanisole, and then apply these findings to the synthesis of indole derivatives. The conditions for the reaction were the same as the example in the literature reported previously,¹²⁴ with changes in temperature, reaction time and palladium source, but the results were unsuccessful. The results obtained are shown in Table 14.

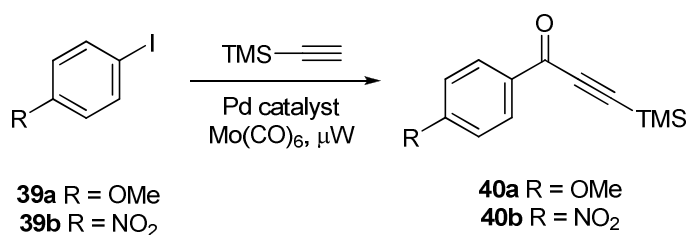
Table 14. Carbonylation attempts^a

Entry	Substrate	Reagents	Temp. [°C]	Time [Min]	Results [%]
1 ^c	39a	Pd(OAc) ₂ (4 mol%), Mo(CO) ₆ (1 equiv), DBU (3 equiv), THF	100	15	Traces of 40a ^b
2	39a	same as entry 1	100	15	Traces of 40a ^b
3 ^d	39b	Pd/C (7 mol%), K ₂ CO ₃ , DME	150	15	Traces of 40b ^b
4 ^c	39a	Pd(OAc) ₂ (4 mol%), Mo(CO) ₆ (1 equiv), CuI (2 mol%), NEt ₃ (1 equiv) DBU (3 equiv), THF	120	60	impurities and 39a
5 ^e	39a	Pd[PPh ₃] ₄ (5 mol%), CuI (2 mol%), NEt ₃ (1 equiv), Mo(CO) ₆ (1.1 equiv), THF dry	120	60	Traces of 40a ^b
6 ^c	39a	Pd(OAc) ₂ (10 mol%), Mo(CO) ₆ (1 equiv), DBU (3 equiv), THF dry	100	15	impurities and 39a
7 ^c	39a	Pd[PPh ₃] ₄ (10 mol%), Mo(CO) ₆ (1 equiv) DBU (3 equiv) THF dry	100	15	impurities and 39a
8	39a	Pd[(PPh ₃) ₂ Cl ₂] (1 mol%), Mo(CO) ₆ (1 equiv) NH ₃ aq., THF	150	60	impurities and 39a
9	39a	Pd[PPh ₃] ₄ (1 mol%), Mo(CO) ₆ (1 equiv) NH ₃ aq., THF dry	50→150	60	impurities and 39a
10	39a	Pd[PPh ₃] ₄ (2 mol%), Mo(CO) ₆ (1 equiv) NH ₃ aq., THF dry	50→150	30	impurities and 39a
11	39a	Pd[PPh ₃] ₄ (10 mol%), Mo(CO) ₆ (1.5 equiv) NEt ₃ (3 equiv), H ₂ O	100	60	impurities and 39a
12	39a	Pd[PPh ₃] ₄ (10 mol%), NEt ₃ (3 equiv) gaseous CO, H ₂ O	r.t.	overnight	impurities and 39a

^aReactions were carried out using aryl iodide **39** (1 equiv) and TMS-acetylene (1.2 equiv) in the presence of a Pd catalyst and Mo(CO)₆ in THF, unless otherwise stated; ^b IR spectroscopy revealed the presence of the carbonyl group; ^c 3 equiv. of TMS-acetylene were used for this reaction; ^d 1.3 equiv. of TMS-acetylene were used for this reaction; ^e 1.5 equiv. of TMS-acetylene were used for this reaction.

The desired compound was obtained in very small quantities after purification of the crude product by column chromatography (entries 1, 2, 3, 5). Analysis by IR spectroscopy on the crude reaction mixture (entry 2) revealed the presence of the carbonyl group, as expected from the reaction between Mo(CO)₆ and 4-iodoanisole. Different temperatures were used in order to optimize the reaction conditions (from r.t. to 150 °C). When the temperature was set at 150 °C, a rapid increase in pressure was experienced (up to 200 psi in 10-12 sec, entries 3 and 8), so it was decided to increase the reaction temperature slowly (entries 9 and 10), starting from 50 up to 150 °C. Because of the very poor results achieved using an external source of CO (2 bar), it was decided to resort to the use of gaseous CO (entry 12) but even in this case the desired product was not obtained.

A different approach to prepare compound **37** was then taken in consideration, as illustrated by retrosynthetic analysis in Scheme 84.

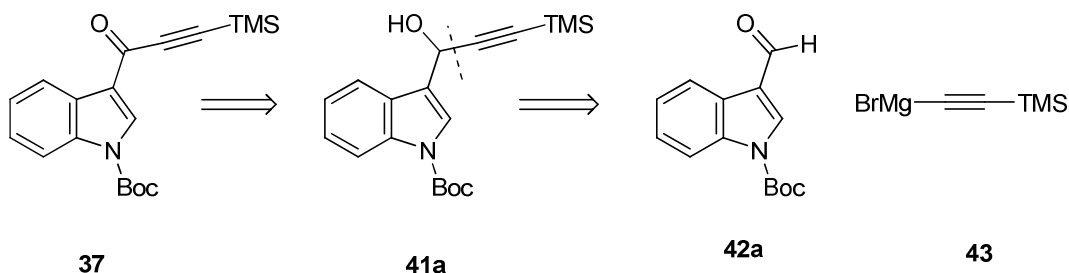

Scheme 84. Disconnection approach to molecule **37**

This approach was based on the preparation of the alkynones **27**, previously reported in Discussion, paragraph 2.1.2. Using the commercially available indole-3-carboxaldehyde, it could be possible to introduce the TMS-alkynyl group *via* reaction of compound **42** with the corresponding Grignard reagent **43** and then oxidize the alcohol **41a** to obtain the desired alkynone **37**.

The first step was the preparation of the Grignard reagent **43** by reaction of the TMS-acetylene **44** with metallic magnesium and butylbromide.¹²⁶

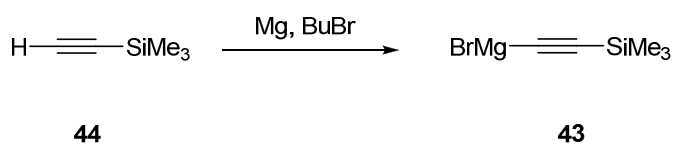

Scheme 85. Preparation of the Grignard reagent

The corresponding TMS-ethynylmagnesiumbromide **43** was not isolated but was used directly for the reaction with the unprotected indole-3-carboxaldehyde (**42b**) (Scheme 86).

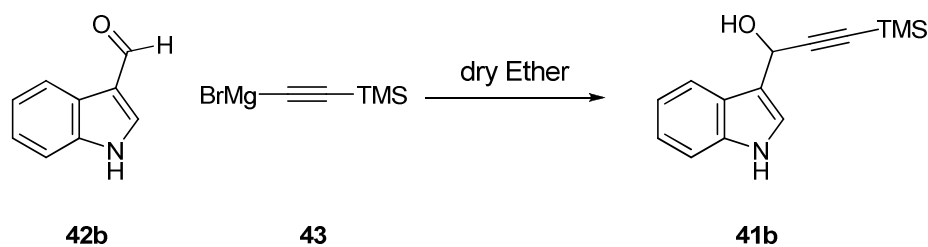

Scheme 86. Reaction of the aldehyde with the Grignard

After purification by column chromatography and spectroscopic analysis, it was not possible to identify the desired compound **41b**, probably due to the fact that the unprotected nitrogen of the indole ring interfered with the reaction.

2.4.3 Conclusions

Despite different attempts to form the required substituted indole **37** for the subsequent pyrimidine formation, it was not possible to complete the synthesis. The initial studies on the carbonylation reaction were not successful and that approach was replaced by an alternative one, as illustrated in Scheme 84. This approach looked promising but protection of the indole nitrogen should be considered before carrying out the subsequent reaction with a Grignard reagent. As part of future work, the reaction in Scheme 86 will be repeated by first protecting **42b** and then by trying different organometallic reagents to achieve the desired compound **41b**.

**Chapter 3: A new microwave mediated Ullmann-
condensation and its application to the synthesis of drug
candidates of pharmaceutical relevance**

3.1 Metal mediated C–S bond formation under MW irradiation

3.1.1 Introduction

Aryl sulfides are very useful intermediates in organic synthesis. A large number have been reported as having pharmaceutical, biological and material applications and many aryl sulfide-containing compounds show promising pharmacological and biological activities.¹²⁷ Numerous methodologies have been developed for the synthesis of this particular class of compounds, but many of them suffer from harsh conditions (long reaction times and high temperatures) in order for the reaction to go to completion. In only a few cases has microwave power been utilized to try to accelerate and facilitate this transformation, but without a reliable and reproducible outcome.

At the beginning of the 20th century a new class of coupling reaction was disclosed by the pioneering work of Fritz Ullmann and Irma Goldberg (Scheme 87):¹²⁸

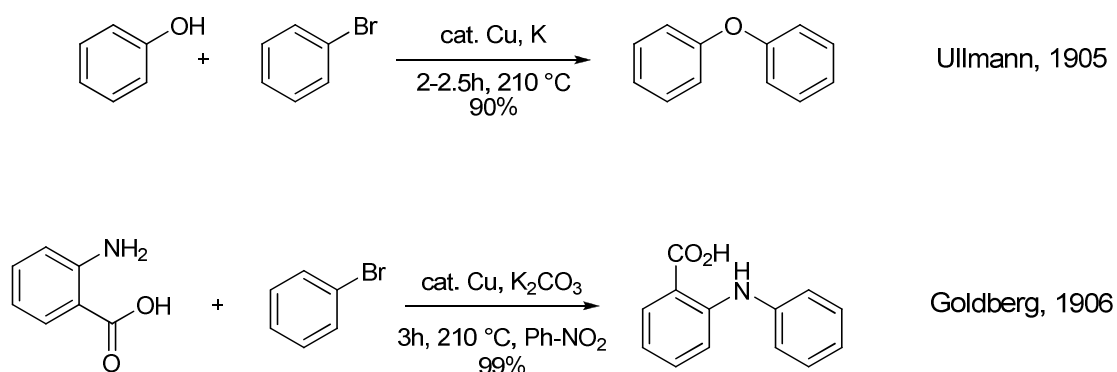

Scheme 87. Initial work from Ullmann and Goldberg

These reactions typically involved the coupling of aromatic halides with amines and phenols for the synthesis of the corresponding aromatic compounds. Typical reaction conditions suffered from disadvantages such as high reaction temperatures, the use of toxic solvents such as HMPA, and intolerance towards a wide-variety of functional groups. The biggest drawback of the classical Ullmann reaction arose because of variability of outcome depending upon the copper source. Despite these drawbacks and the development of complementary palladium-based methodology, copper-mediated reactions remain the reactions of choice in large and industrial scale transformations of this nature.

Mechanistic studies have been carried out in previous years and a number of catalytic cycles have been proposed for comparison with the classic $S_{RN}1$ reaction.¹²⁹ Overall, two catalytic cycles have been considered: one in which there is a change of the oxidation state for the catalyst and the second one in which there is no change in oxidation state. Copper is shown as the catalyst but this model is valid for other transition metal catalyst (Pd, Ni, Fe) mediated processes.

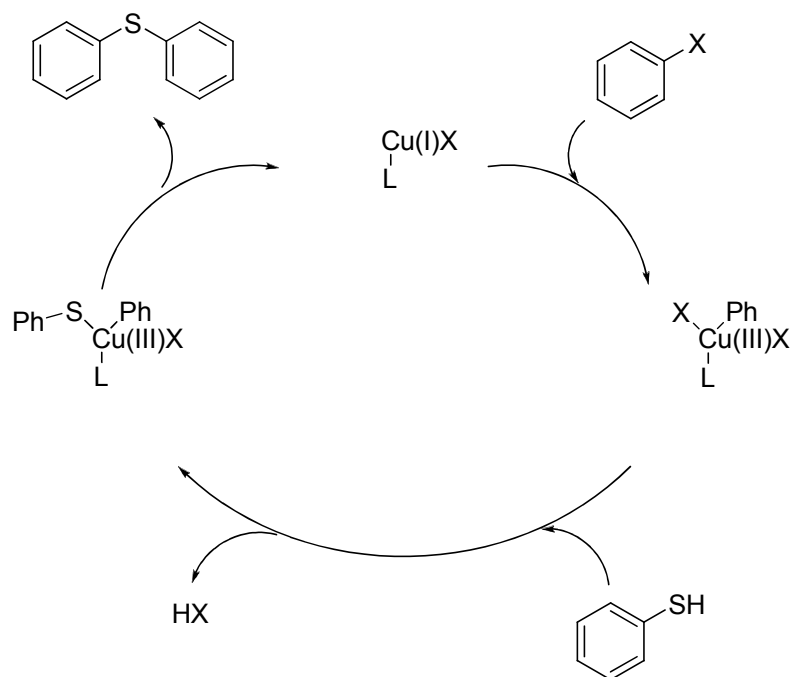

Figure 25. Catalytic cycle with catalyst oxidation state change

The catalytic cycle in Figure 25 is an *oxidative addition* path in which the aryl halide oxidatively adds to copper, resulting in a copper (III) intermediate. Copper (III) existence is doubtful but it is possible to find several structures in the Cambridge Crystallographic Database in which copper is assigned with this oxidation state. This type of catalytic cycle has been shown to be operative in palladium and gold catalyzed cross-coupling reactions.¹³⁰ After a nucleophile-halogen exchange on copper the resulting intermediate reductively eliminates the coupled product, regenerating the active copper (I) catalyst.

From mechanistic studies on this type of catalytic cycle it has been proposed that, for the case where electron-withdrawing substituents are present on the aryl halide, the rate of reaction would be enhanced due to the increase in the rate of oxidative addition. On the other hand, electron-donating groups on the aryl halide would decrease the rate of oxidative addition, thus decreasing the rate of reaction.

Another mechanistic possibility is one in which the catalyst does not undergo oxidation state change, as proposed in Figure 26. This catalytic cycle has been called sigma-bond metathesis by analogy with related processes involving a four centred intermediate, despite the fact that traditional mechanisms of this nature occur for d^0 metal complexes (that can't readily change oxidation state) whereas copper ($d^{10}s^1$) or palladium, (d^{10}) can change their oxidation state readily.

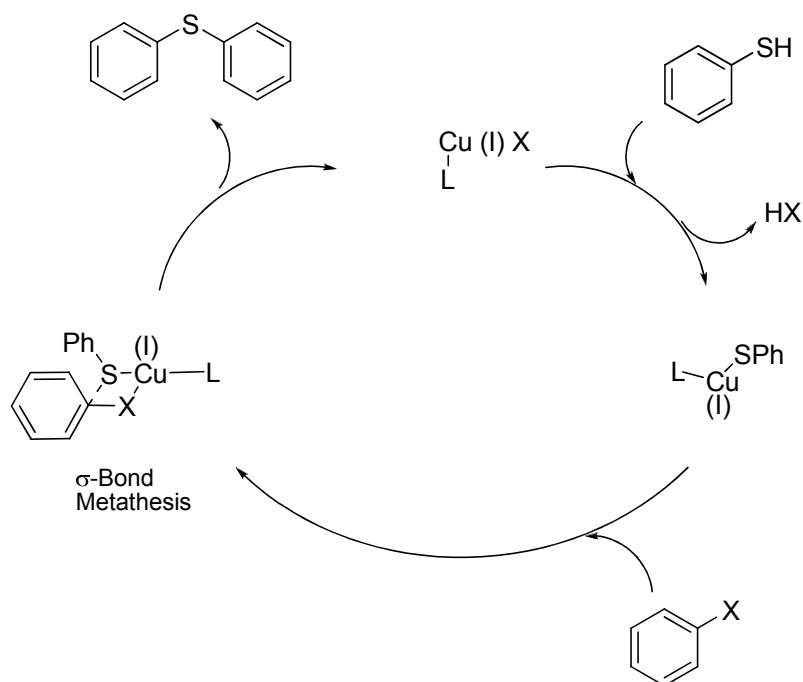

Figure 26. “ σ -Bond metathesis” proposed mechanism

The first step in this mechanism is displacement of the halide to form a [Cu]-Nu species that subsequently catalyzes the coupling. The copper catalyst must then coordinate to the aryl halide *via* a 4-centered intermediate. The orientation of the coordination can be readily determined by assigning partial charges to the copper catalyst and the aryl halide. The halide is electronegative and creates a partial positive charge on the aromatic ring *ipso* to the halide, similar to the partial charges assigned in aromatic nucleophilic substitution reactions. The copper catalyst is of course in the +1 oxidation state and therefore the nucleophile can be assigned a partial negative charge. This type of orientation/coordination should therefore exhibit no substantial differences in rate or reactivity as a function of substitution. Thus, similar reactivity patterns should be observed for both electron withdrawing and electron donating aryl halides.

3.1.2 Goal of this study

From an examination of the literature, it is apparent that there is a lack of methods for rapid microwave-mediated C–S bond formation. The goal of this study is to promote the formation of a carbon–sulfur bond in a fast and reliable way, using microwave power to shorten the reaction time, drive the reaction to completion and simplify purification processes (that could arise from conducting this type of transformation with conventional heating), taking into account undesirable catalyst and ligand cost and presence in the reaction medium. Having found a new method, a library of compounds would be produced to test the applicability of the method.

No rigorous mechanistic investigation into C–S bond formation has been carried out but, at the end of this study, qualitative data on the catalytic cycle that could be operating for this kind of transformation might also be gained.

3.1.3 Reviewing Available Methods for C–S Bond Formation

In order to establish the facility of any new method, first we set out to determine the capability of previously reported procedures. Thus, methods were selected from the literature, repeated under microwave irradiation, analyzed and compared for speed, efficiency, convenience and facility, by variation in catalyst, ligand, base and solvent, with particular emphasis on accelerating the process. A first system worthy of note was reported in 2004 as an example of a transition metal-free method for C–S bond formation.¹³¹ This literature report described the use of CsOH·H₂O as base in DMSO and gave the corresponding sulfide in a very short time (5-20 min) and in good yield (42-90%) (Scheme 88). A variety of substrates were explored: aryl iodides and bromides bearing electron-withdrawing substituents were coupled with mainly aryl thiophenols, some of them bearing electron-donating substituents. As expected, aryl iodides were more reactive than the corresponding bromides and the reaction gave better results with benzyl mercaptans instead of thiophenols. A nucleophilic aromatic substitution was proposed as the operating mechanism in presence of a strong base such as caesium hydroxide, even for electron rich aryl halides.

The first results obtained could have seemed promising, considering the good yields (75% and 55%) and the very short reaction times but unfortunately were misleading. ¹H NMR spectroscopic analysis suggested the formation of the desired sulfide but LR-MS analysis indicated unequivocally that the main product of the reaction was diphenyl disulfide, very likely as a consequence of reaction exposure to oxygen. Further experiments, carried out under an inert atmosphere, changing reaction times and temperatures, were performed (Table 15, entries 3-6). The reaction was initially repeated at the higher temperature of 160 °C for 6 min, loading the starting materials under a nitrogen atmosphere (entry 3). Further attempts were carried out, increasing the reaction time to 15 minutes (entry 4) and 7.5 minutes (entry 5) respectively, leaving the reaction temperature unchanged. Furthermore, the reaction was also performed for 10 min at 100 °C (entry 6). From all of these experiments, the desired sulfide was obtained in 11, 27, 26 and 15% yield, respectively, after aqueous work-up. Although the correct product was generated, these results indicated that the yield of reaction was considerably lower than the original report. Despite this significant shortcoming, the reaction seemed to operate better at 120 °C instead of at lower or higher temperatures. A comparison of conventional heating techniques with the microwave irradiation method was then conducted (entry 7, 8 and 9). Initially the reaction was performed at 100 °C for 10 min under a nitrogen atmosphere and the sulfide was obtained in 17% (entry 7) and 30% yield (entry 8), respectively, after just a simple extraction. In this particular case, the transformation did not seem to have any benefit from microwave irradiation. Furthermore, it was decided to perform the reaction using 4-nitroiodobenzene, an aryl halide with an electron-withdrawing substituent, to enhance its reactivity. The reaction was conducted at room temperature for 4 hours (entry 9); after workup, the desired compound was isolated in 26% yield. Microwave irradiation was applied to the reaction mixture for 10 min at 120 °C (entry 10), obtaining the product in only 11% yield. The electron-poor substituent on the aryl halide did not enhance the reactivity nor facilitate this reaction and so this method was abandoned.

One of the earliest publications on Ullmann-type coupling was the breakthrough work of Migita and co-workers in 1980 (Scheme 89).¹³² The reaction of aryl iodides or bromides with arene- or alkanethiol, using sodium *t*-butoxide as base in presence of a catalytic amount of *tetrakis*(triphenylphosphine)palladium(0) in a protic solvent was found to be efficient for the C–S bond formation. Palladium(II) acetate was also used to catalyze the reaction, even if lower yields of diphenyl sulfides were obtained when it was used, compared to Pd(0). Aryl chlorides were tested but they were not as effective as the iodide or bromide substrates. Aryl halides bearing electron-donating substituents were used as well as electron-withdrawing substituents with good results in both cases. Conventional heating was used with good conversions but long reaction times.

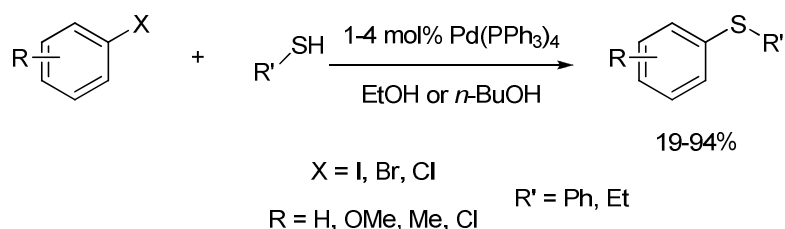

Scheme 89. Migita's approach to Ullmann-type sulfide formation

It was decided to re-investigate this reaction, aiming to explore the applicability of this method and to reduce the reaction time, *via* application of microwave irradiation. The simple bromobenzene **39c** was chosen as a suitable aryl halide for study, alongside palladium acetate as the chosen catalyst because it is stable and soluble in organic solvents. Initially the reaction was heated for 15 h at 100 °C using conventional heating (Table 16, entry 1) but just starting material was recovered at the end of the reaction. Prolonging the reaction time to 29 h (entry 2) and heating at reflux for a day (entry 3) gave only unreacted starting material. This experiment was then repeated under microwave irradiation in a CEM microwave synthesizer for 2 h at 100 °C (entry 4), under anhydrous conditions. Unfortunately, a mixture of unreacted starting materials and unrecognized impurities were the only materials recovered after aqueous work up. As a last resort, the reaction was repeated using an aryl halide bearing an electron-withdrawing substituent, 4-nitroiodobenzene. The reaction was performed for 1 hour at 100 °C (entry 5) and for this substrate the desired sulfide was recovered in a very low yield (12%) at the end of the reaction. Given the lack of success of the Pd-mediated process in the absence of an added ligand, this study was abandoned.

bromides in the presence of Pd₂(dba)₃/Xantphos and potassium carbonate as base in xylene. Typically experiments were performed at 140 °C for 24 h, the harsher conditions (longer reaction times and higher temperatures) being necessary in order to react aryl triflates and bromides.

The possibility of applying microwave power to these methodologies was interesting and thus was considered in our next series of experiments. A test reaction using 4-nitroiodobenzene and thiophenol in presence of the Pd(OAc)₂/XantPhos in dioxane was performed. Pd(OAc)₂ was chosen because of its ready availability and solubility. Three cycles of 30 min each at 100 °C were performed in the CEM microwave synthesizer, followed by aqueous workup and purification by column chromatography, but the results of this experiment was disappointing (Table 17, entry 1). The reaction was repeated initially increasing the time of reaction (entry 2), obtaining the desired compound in a better yield (61%). Despite this, another attempt by increasing time and temperature (entry 3) did not give appreciable improvements.

Table 17. Results with a Pd source and a phosphine ligand^a

	45a	39b		46b		
			Pd(OAc) ₂ , XantPhos <i>i</i> -Pr ₂ NEt, Dioxane			XantPhos
Entry	Time [min]		Temperature [°C]	46b Yield [%] ^b		
1	90		100	11		
2	180		100	61		
3	180		140	65		

^a Reactions were carried out using **39b** (1 equiv), **45a** (1 equiv), Pd(OAc)₂ (2.5 mol%), XantPhos (5 mol%) and *i*Pr₂NEt (2 equiv) in dioxane at the given temperature by modulating the initial microwave power (100 W) under anhydrous conditions; ^b Isolated yield after purification by column chromatography.

One application of microwave power to the cross-coupling reaction of aryl halides and thiols was published in the literature (Scheme 91).¹³⁴

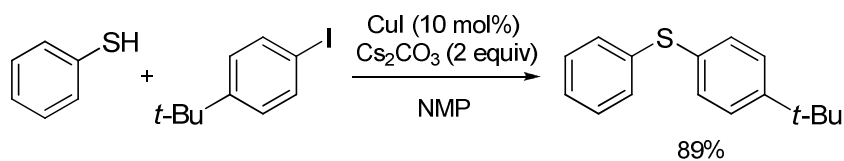

Scheme 91. CuI/CsCO₃ method

In this report in 2003, Wu and He described the application of a method for coupling aryl halides with alcohols¹³⁵ under microwave irradiation to the reaction of thiols. They tested the reaction of 1-*tert*-butyl-4-iodobenzene with 1 equivalent of benzenethiol in presence of copper (I) iodide and caesium carbonate in *N*-methylpyrrolidone at 195 °C for 2 hours under microwave irradiation and obtained the desired sulfide in 89% yield. Interestingly, their comparison in a control experiment performed under conventional heating gave a lower yield of product (67%). A variety of aryl iodides and bromides were used, although many of the obvious substrates to report had not been investigated, and even unactivated aryl bromides gave good results, but with a prolonged reaction times and slightly lower yield in some cases. Aryl chlorides were not used and no mechanism was proposed for this transformation.

Given this startling success and mechanistic ambiguity of this process, we set out to investigate the reaction of bromides with electron-rich or electron-poor systems under similar conditions. A test reaction was set up using the simple bromobenzene **39b** with one equivalent of thiophenol **45a** in the presence of 10 mol% of Cu(I) iodide and caesium carbonate as base (Table 18, Entry 1). Bromobenzene was chosen because of the lack of electronic effects compared to an aryl halide with electron-withdrawing or -donating substituents. The mixture was irradiated at 120 °C for three cycles of 30 min each in a CEM Discover[®] microwave synthesizer. After purification by column chromatography on silica, the desired compound was isolated in 18% yield and the presence of unreacted starting material was observed. In order to accelerate the reaction, it was decided to increase the temperature to 150 °C, and so the experiment was repeated, using two cycles of 30 min irradiation each (entry 2), but no improvement in the outcome was observed. It was then decided to replicate the exact conditions described in the original paper, changing temperature and time accordingly (entry 3) but the results were no different from previous experiments. Even if in the original paper no difference was noted in the reactivity of electron-rich and electron-poor

Very recently (2006 and 2007), reports of new palladium complexes of stable *N*-heterocyclic carbenes (NHCs) have been published (Figure and Table 19),¹³⁶ which proved very useful in cross-coupling reactions such as the Negishi-coupling, the Kumada-Tamao-Corriu-coupling and the Suzuki-Miyaura-coupling.

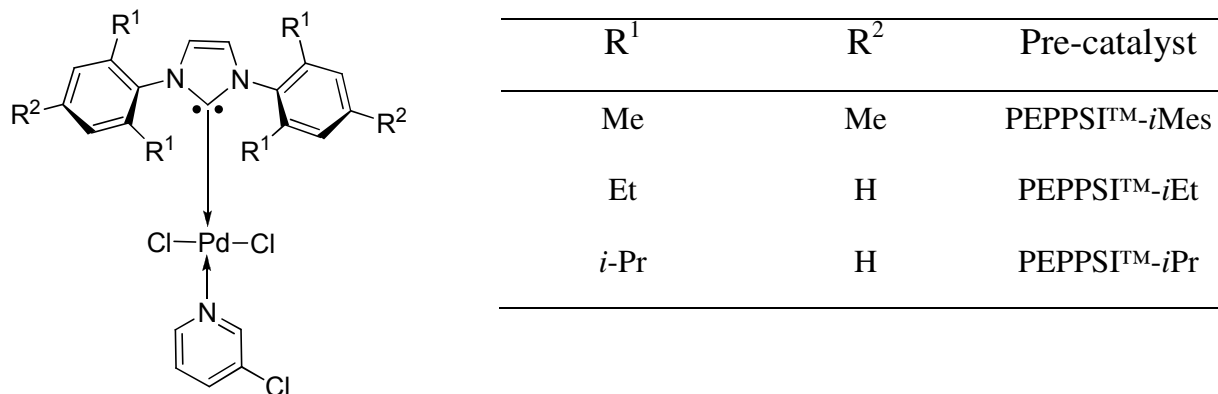
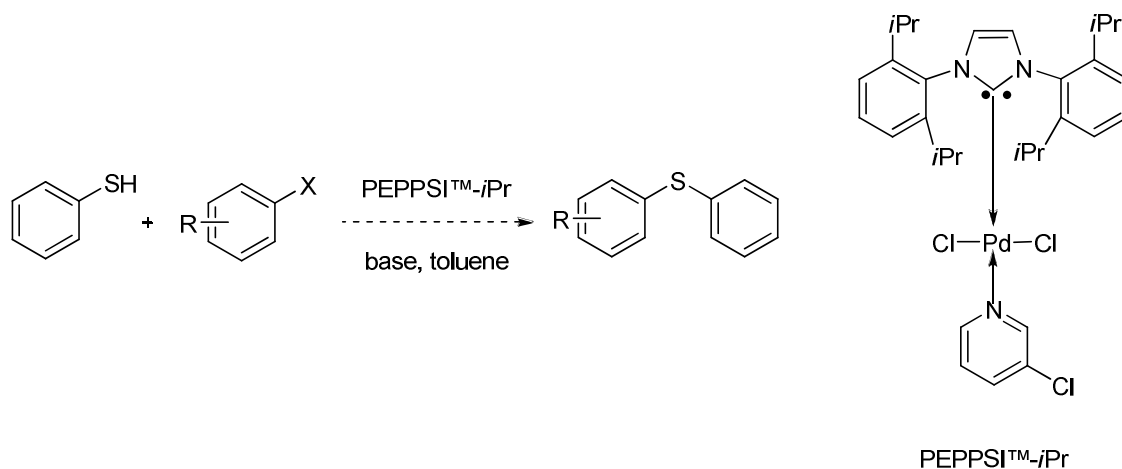

Figure and Table 19. New Pd pre-catalyst

NHCs exist in the singlet state, with a pair of electrons perpendicular to the plane of the π system. This mimic of a phosphine system suggested their possible use in catalysis: the σ -donating ability results in a Pd centre capable of undergoing oxidative addition with substrates such as haloarenes; the strong Pd-NHC bond ensuring the metal is in solution and in a catalytically-active state while the steric bulk of the NHC ligand facilitates reductive elimination. Pd(II)-NHC complexes are air-, moisture- and heat-resistant, can easily generate Pd(0) in solution and can be stored for prolonged periods of time without degradation. Considering the very interesting findings concerning the application of this catalyst in the Buchwald-Hartwig C–N bond formation, it was very tempting to test this substrate in a C–S bond forming reaction (Scheme 92).



Scheme 92. Proposed PEPPSI-mediated C–S bond formation

For preliminary studies, it was chosen to use an aryl halide bearing an electron-withdrawing substituent such as 4-nitroiodobenzene for its electronic properties. In fact, a nitro group is believed to favour the oxidative addition step on the halide (in the case of a catalytic cycle where the catalyst oxidation state changes).

Table 20. PEPPSI-mediated C–S bond formation using an electron-withdrawing halide^a

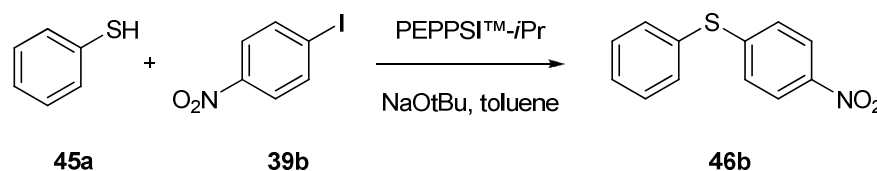

Entry	Reagents	LiCl [mol%]	PEPPSI TM -iPr [mol%]	Yield [%] ^b
1	39b (1 equiv), NaOtBu (1.5 equiv), PhMe	–	2	45
2 ^c	39b (1 equiv), NaOtBu (1.5 equiv), PhMe	–	2	10
3	39b (1.3 equiv), NaOtBu (1.5 equiv), dioxane	20	2	45
4	39b (1.3 equiv), K ₂ CO ₃ (2 equiv), dioxane	20	2	44
5 ^d	39b (1 equiv), K ₂ CO ₃ (2 equiv), dioxane	20	5	55
6 ^e	39b (1 equiv), NaOtBu (1.5 equiv), PhMe	–	–	47
7	39b (1 equiv), NaOtBu (1.5 equiv), PhMe	20	2	74
8 ^e	39b (1.3 equiv), NaOtBu (1.5 equiv), PhMe	20	–	80

^a Reactions were carried out using **39b** (1-1.3 equiv), **45a** (1 equiv), PEPPSITM-iPr (2-5 mol%), a selected base and solvent for 3 hours at 120 °C (initial power 150 W) under anhydrous conditions; ^b Isolated yield after purification by column chromatography; ^c Reaction was carried out for 1 hour at 150 °C (initial power 150 W); ^d Reaction was carried out for 2 hours at 120 °C (initial power 150 W); ^e Reaction was carried out using 1.1 equiv of **45a**.

With 4-nitroiodobenzene, 1 equivalent of thiophenol was added in presence of 2 mol% of the catalyst PEPPSITM-iPr and 1.5 equivalents of sodium *tert*-butoxide in toluene. To avoid formation of disulfides as undesired products of the reaction and to ensure no oxygen was present in the test tube, the loading of the reagents was performed under a nitrogen atmosphere. The mixture was then irradiated for three cycles of 3 hours each at 120 °C to give the desired sulfide in 45% yield after filtration and purification by column chromatography (Table 20, entry 1). Performing the reaction at a higher temperature of 150 °C for 1 hour gave the product in lower yield (10%) (entry 2). From entry 3 lithium chloride was used as an additive. The use of LiCl as an additive in Pd-mediated reactions has been reported for Heck and Stille-coupling reactions and it is believed to enhance the reactivity by promoting the oxidative addition step.¹³⁷ The reaction of the aryl halide (1.3 equiv, instead of 1 equiv, entry 3) in the presence of 20 mol% of lithium chloride was investigated in dioxane but gave

comparable results (see entry 1). Changing the base and the amount of catalyst was also considered (entries 4 and 5): the use of potassium carbonate (2 equiv) instead of sodium *tert*-butoxide (entry 4) was investigated but the sulfide was obtained in yields comparable to the original test reaction (44% compared to 45%). However, a significant increase in yield was obtained with a slight increase in the catalyst amount, to 5 mol%, in the presence of potassium carbonate as base in dioxane. A control reaction with no catalyst and additive was performed in the presence of sodium *tert*-butoxide in toluene: the desired product was obtained in 47% yield, confirming the assumption that this particular reaction could proceed *via* nucleophilic aromatic substitution (but it was still anticipated that a catalytic mechanism could contribute to the reaction outcome). Replacing the dioxane solvent with toluene (entry 7) and performing the reaction using the same parameters as entry 3 gave the expected sulfide in a very good (74%) yield. Surprisingly, removing the catalyst from this reaction mixture provided the sulfide **46b** in an even more satisfying 80% yield. Although this provides an indication that a metal-mediated mechanism does not dominate for this substrate, further investigation would be required to further elucidate the exact mechanistic pathway.

Considering the good results obtained with an electron-poor halide, it was decided to expand the use of the PEPPSITM-*i*Pr system to other substrates with different electronic requirements to expand the scope of this process. For this reason, the next reactions utilized a simple bromobenzene followed by an heteroaromatic halide such as 2-iodopyridine (Table 21).

Initially, bromobenzene (1 equiv) was reacted with thiophenol (1 equiv) in the presence of the chosen catalyst in toluene at 100 °C (Table 21, entry 1), but after 30 min only starting materials were recovered at the end of the reaction, with tiny traces of product visible by TLC analysis. An increase in the reaction time (up to 3 hours) and temperature (up to 120 °C) did not give any different result (entry 2 compared to entry 1). In the case of an heteroarene halide such as 2-iodopyridine, the desired product was obtained in 64% yield following purification by column chromatography after 3 hours reaction at 120 °C (entry 3).

Table 21. Expanding this methodology to different substrates^a

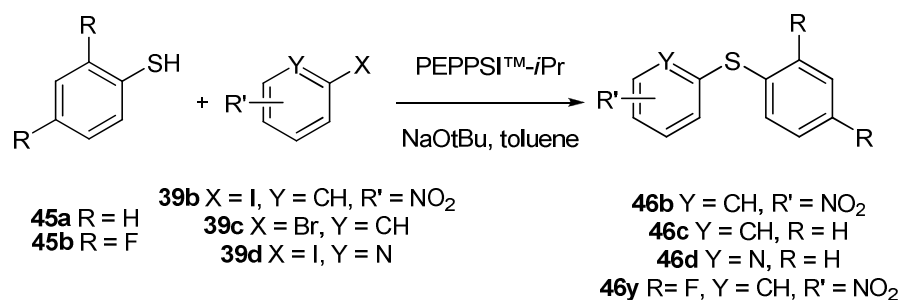

Entry	Substrate	LiCl [mol%]	Time [h]	Temperature [°C]	Results (yield [%]) ^b
1	39c	–	0.5	100	46c (trace), 45a , 39c
2	39c	–	3	120	46c (trace), 45a , 39c
3	39d	–	3	120	46d 64
4	39d	20	3	120	46d 88
5 ^c	39b	–	2	130	46y 41
6 ^d	39b	–	3	120	46y 28

^a Reactions were carried out using **39b/c/d** (1 equiv), **45a** (1 equiv), PEPPSITM-iPr (2 mol%) and NaOtBu (1.5 equiv) in toluene under microwave irradiation for the given time at the indicated temperature under anhydrous conditions; ^b Isolated yield after purification by column chromatography; ^c Reaction was conducted using **39b** (1.5 equiv), 2,4-difluorothiophenol **45b** (1 equiv) and PEPPSITM-iPr (5 mol%); ^d Reaction was conducted using **39b** (1 equiv) and 2,4-difluorothiophenol **45b** (1 equiv).

Interestingly, the presence of lithium chloride as additive was beneficial to the reaction outcome, possibly due to activation of the halogen ring in the oxidation step (entry 4): the final compound was obtained in better yield and the profile of the reaction was clearer because, at the end of the process, less starting material was present and thus the purification by column chromatography was simplified. The use of a different thiol (**45b**) was also investigated in order to expand the methodology: 2,4-difluorothiophenol was chosen (entry 5) and the reaction was performed at 130 °C for 2 h, giving the desired product in 41% yield. An attempt to increase the reaction time to 3 h, decreasing the reaction temperature to 120 °C, did not correspond to a higher yield (28 instead of 41%, entry 6). Possibly, a better result could be obtained by using LiCl as additive but this reaction has not been tried for the substrates **39 b/c** and could be part of future work.

Having tested this catalytic system with electron-withdrawing and “electron-neutral” substituents on the aryl halide and having obtained a higher yield of product with the former, it was therefore decided to test this process with the electron-rich halide, 4-iodoanisole. Initial tests were performed in the absence of the catalyst, changing the stoichiometry of the reaction (as shown in Table 22). The experiment was performed at 80 °C for 2 hours (1.3 equiv of

iodoanisole to 1 equiv of thiophenol) (entry 1) and at 120 °C (entries 2 and 3) for up to 3 hours (inverting the stoichiometry in entry 3: 1.5 equiv of thiophenol to 1 equiv of iodoanisole). Only starting materials were recovered at the end of these attempts and, because of this, it was decided to use a catalyst and additive to accelerate the reaction.

Table 22. PEPPSI-mediated reaction between iodoanisole and thiophenol^a

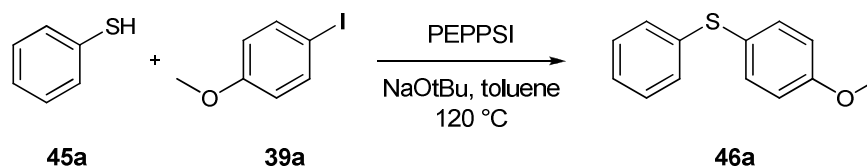

Entry	45a [equiv]	39a [equiv]	PEPPSI TM - <i>i</i> Pr [mol%]	LiCl [mol%]	Result (yield [%]) ^b
1 ^c	1	1.3	–	–	45a, 39a
2	1	1.3	–	–	45a, 39a
3	1.5	1	–	–	45a, 39a
4	1	1.3	2	–	45a, 39a, 46a (trace)
5	1	1.3	2	20	45a, 39a, 46a (trace)
6	1.5	1	2	20	45a, 39a, 46a (trace)
7	2.5	1	2	20	46a 9 ^d

^a Reactions were carried out using **39a** (1 equiv), **45a** (1 equiv), PEPPSITM-*i*Pr (2 mol%) and NaOtBu (1.5 equiv) in toluene under microwave irradiation for the given time at the indicated temperature under anhydrous conditions; ^b Results were observed after ¹H NMR spectroscopic analysis on the crude reaction mixture; ^c Reaction was conducted at 80 °C for 2 h under microwave irradiation; ^d Isolated yield after purification by column chromatography.

Unfortunately, the reaction outcome was not improved, even in the presence of the PEPPSI catalyst and lithium chloride. Only when 2.5 equivalents of thiophenol were used was the outcome any different, the desired sulfide being obtained in a miserable 9% yield (entry 7).

Considering these results, it was evident that this methodology was not widely applicable and, because of this, it was decided to test another process adapted from the literature. In 2002 an interesting synthetic protocol was presented by Venkataraman *et al.* that used a copper source with a phenanthroline derivative as ligand under conventional heating (Scheme 93).¹³⁸

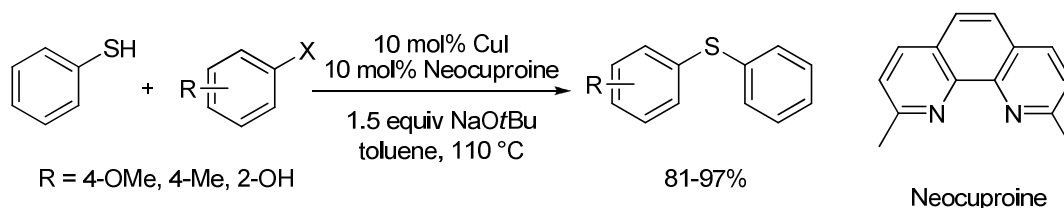

Scheme 93. C–S bond formation by the procedure of Venkataraman

The ligand/catalyst choice was based upon previous findings within the Venkataraman group¹³⁹ and, with this system, sodium *tert*-butoxide proved a more effective base compared to other choices. Using this protocol, a variety of aryl and alkyl thiols were effectively coupled with aryl iodides in toluene at 110 °C for 24 hours under conventional heating. Clear advantages with this methodology were the use of an inexpensive and air-insensitive ligand such as the neocuproine and the possibility to couple even sterically hindered thiophenols with iodobenzene in good yield. The drawback was the long reaction time and the fact that the protocol was not efficient with other halides.

To overcome these limitations, it was decided to investigate this method, with the aim to reduce the reaction time *via* microwave power and to expand the applicability of the method to encompass other halides such as bromo-derivatives. For the first test, it was decided to react 4-iodonitrobenzene with thiophenol in the presence of 10 mol% of copper iodide, 10 mol% of neocuproine and 1.5 equiv. of base in toluene. The reaction was performed at 80 °C for 3 hours in a CEM Discover[®] microwave synthesizer using the concurrent heating and cooling mode (that ensures more microwave power applied to the test tube because of continuous cooling in a stream of compressed air) (Table 23, entry 1).¹⁴⁰ The desired sulfide was obtained in 61% yield after purification by column chromatography.

Table 23. Cu(I)-neocuproine mediated synthesis of **46b**^a

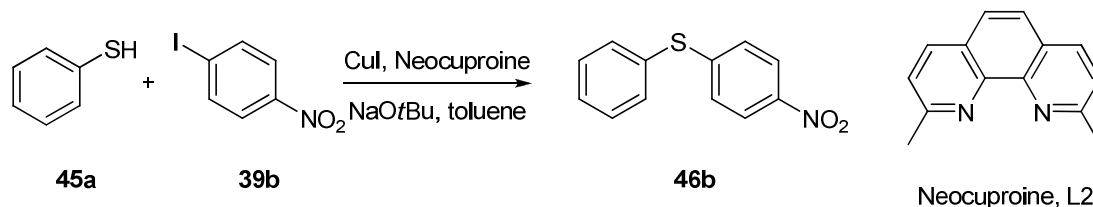

Entry	CuI [mol%]	L2 [mol%]	Temperature [°C]	46b Yield [%] ^b
1 ^c	10	10	80	61
2	10	10	100	60
3	–	10	100	70
4	–	–	100	58
5 ^d	–	–	120	45
6 ^e	10	10	120	84

^a Reactions were carried out using **39b** (1 equiv), **45a** (1.1 equiv), copper(I) iodide (10 mol%), neocuproine (L2, 10 mol%) and NaOtBu (1.5 equiv) in toluene for 3 h (hold time) under anhydrous conditions; ^b Isolated yield after purification by column chromatography; ^c Concurrent heating and cooling mode; ^d Reaction was carried out for 2 h using **39b** (1.5 equiv), **45a** (1 equiv), K₂CO₃ (2 equiv) in dioxane; ^e 2,4-difluorothiophenol **45b** (1.1 equiv) was used instead of thiophenol **45a**.

An increase in the reaction temperature (entry 2) did not correspond to any improvement in the yield but, interestingly, removing the catalyst from the reaction medium gave the product in a higher yield (70%, 10% improvement over entry 1). A possible explanation for this observation is a coordination role performed by this ligand in the generation or reaction of the thiophenoxide but further investigation would be required to fully understand this result. In fact, removal of the ligand and the catalyst from the reaction medium (entry 4) still provided the sulfide, but in a lower yield (58%), which is further evidence of a S_NAr mechanism for this electron-poor aryl halide. A further attempt to force the reaction to completion in the absence of catalyst and ligand was made, increasing the reaction temperature (from 100 °C to 120 °C) but over a shorter reaction time (2 h rather than 3 h), but this did not provide any improvement in result: the sulfide was obtained in a lower yield (45% compared to 58% for entry 4).

Given the initial success of this method, the next step in our improvement of this protocol was its application to a different substrate. 2-Iodopyridine was chosen, so that a direct comparison could be made with results obtained from previous studies (PEPPSI system).

Table 24. CuI/neocuproine-mediated C–S bond formation under microwave irradiation using 2-iodopyridine^a

Entry	CuI [mol%]	L2 [mol%]	Temperature [°C]	Result (yield [%]) ^b
1	10	10	80	46d 72
2	10	10	120	46d 96
3	–	10	120	46d 76
4	–	10	100	45a, 39d
5 ^c	–	–	120	45a, 39d, 46d (trace)

^a Reactions were carried out using **39d** (1 equiv), **45a** (1.1 equiv), copper(I) iodide (10 mol%), neocuproine (10 mol%) and NaOtBu (1.5 equiv) in toluene at 120 °C for 3 hours under anhydrous conditions; ^b Isolated yield after purification by column chromatography; Results were observed after ¹H NMR spectroscopic analysis of the crude reaction mixture; ^c Reaction was conducted without catalyst and ligand.

Initial reaction of 2-iodopyridine was conducted at 80 °C for 3 hours in a CEM Discover[®] microwave synthesizer and gave the final product, sulfide **46d**, in 72% yield. It was possible to compare this reaction with entry 4 of Table 21 and conclude that a higher temperature or

the use of an additive was needed in order to force the reaction to go to completion. An increase in the reaction temperature (120 °C instead of 80 °C) further optimized the process and provided the final product in a remarkable 96% yield. Further studies were then carried out to establish the role of ligand and/or catalyst. A repeat of the reaction in the absence of catalyst (entry 3) gave the product but in a lower yield (76%). This result could indicate a coordination role for the ligand in generation/reaction of thiophenoxide, even if carrying out the same reaction at a lower temperature (100 °C instead of 120 °C) gave only unreacted starting materials (entry 4). Removal of both the catalyst and ligand from the reaction (entry 5) afforded just unreacted starting materials, with some trace of the desired product by ¹H NMR spectroscopic analysis. This confirmed a role for the ligand in C–S bond formation even with electron-poor halides and indicated that it was unlikely that a copper-mediated process was dominant in this event.

Following this investigation, it was apparent that subsequent studies should be conducted on an electron-rich aryl halide. 4-Iodoanisole, used previously for this type of analysis, was the substrate of choice.

Table 25. CuI/neocuproine-mediated C–S bond formation under microwave irradiation using 4-iodoanisole^a

Entry	L2 [mol%]	Time [h]	Temperature [°C]	Result (yield [%]) ^b
1	10	2	80	46a 41
2 ^c	10	2	80	45a, 39a
3	10	3	120	46a 83
4 ^c	10	3	120	45a, 39a
5 ^d	10	24	110	46a 61

^a Reactions were carried out using **39a** (1 equiv), **45a** (1.1 equiv), copper(I) iodide (10 mol%), neocuproine (10 mol%) and NaOtBu (1.5 equiv) in toluene under anhydrous conditions; ^b Isolated yield after purification by column chromatography; Results were observed after ¹H NMR spectroscopic analysis of the crude reaction mixture; ^c Reaction was carried out using **39a** (1.3 equiv), **45a** (1 equiv) and without catalyst and ligand; ^d Reaction was conducted for 24 h under conventional heating at 110 °C.

The first of a series of experiments (Table 25, entry 1) was carried out using 4-iodoanisole in the presence of both CuI and neocuproine as ligand at 80 °C for 2 hours, giving the desired sulfide in 41% yield. Removing the catalyst and ligand from the reaction medium (entry 2), whilst keeping the reaction conditions unchanged, did not provide any product at all and so indicated that one or both of these were involved in the C–S bond forming reaction. Conducting the reaction at 120 °C for 3 hours afforded the product in 83% yield (entry 3). Even at this higher temperature, reactions carried out in the absence of both catalyst and ligand gave only unreacted starting materials (entry 4). A further comparison of these conditions with conventional conductive heating-mediated reactions (entry 5) carried out at 110 °C for 24 hours, gave the product in 61% yield (Venkataraman obtained **46a** in 96% yield), showing that whilst some progress had been made under microwave irradiation, the capability of this process was far from optimal and required further adjustments.

3.1.4 Conclusions

Of all the methods investigated, based upon adapted literature protocols, the PEPPSI precatalyst-mediated process and the CuI/neocuproine system were the most promising, but both failed to demonstrate wide applicability to different electronic-requirements in substrate. Use of microwave irradiation applied to Venkataraman's conditions contributed to reduce reaction times from 24 h (with conventional heating) to 3 h, even if it was not possible to obtain the same results in terms of yields. Specifically, in the case of **46a** the product was obtained in 83% yield under microwave irradiation (Table 25, entry 3), a result that was close to the one obtained by Venkataraman (96% yield) under conventional heating,¹³⁸ even if a repetition of the same reaction under conventional heating gave a lower result (61% yield, Table 25, entry 5). In the case of **46b/d**, it was not possible to draw the same type of conclusions simply because Venkataraman did not use these two substrates. It was concluded that the copper-catalyzed process seemed to offer some promise for further development and it was decided to further investigate its use, as reported in paragraph 3.2.2.

3.2 Rapid Ullmann type C–S bond formation using Cu(I) catalyst and ligand

3.2.1 Introduction

In 2002, a general and mild method for the cross-coupling of aryl iodides with aryl and alkyl thiols was reported by the Buchwald group (Scheme 94).¹⁴¹

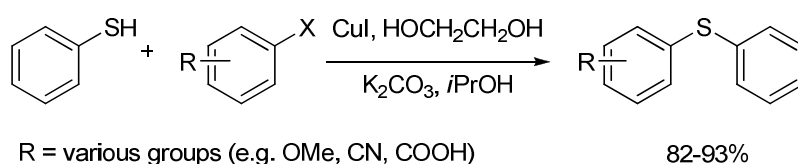

Scheme 94. Buchwald approach to sulfide synthesis

From previous findings within this group concerning copper-catalyzed C–N coupling reactions, an optimized method for C–S bond formation was found that used 5 mol% of Cu(I) iodide as catalyst and ethylene glycol as ligand (and probably co-solvent) in 2-propanol. The reaction proceeded at 80 °C under argon for 18-22 h. Copper(I) was preferred to copper(II) for its stability to air and because copper(I) complexes gave better results. A variety of functionalized aryl iodides and thiophenol were reacted, obtaining the corresponding sulfides in good to very good yields. Keeping in mind the potential enhancements to the process from microwave irradiation, not to mention benefits in purification from a cleaner reaction profile, it was decided to explore this methodology with the application of a microwave source.

3.2.2 Results and Discussion

For the model reaction it was chosen to use at first an aryl iodide bearing an electron-withdrawing substituent such as 4-nitroiodobenzene (because of its electronic effects) and then moving to an aryl iodide with an electron-donating substituent (see Table 26). The initial studies were carried out in the presence of 2 equivalents of potassium carbonate in 2-propanol. Loading the starting materials was carried out under a nitrogen atmosphere to avoid formation of the undesired disulfide.

The reaction was initially performed for 2 h at 85 °C (Table 26, entry 1), but after aqueous work up there was mainly starting material returned with some traces of product present by ¹H NMR spectroscopic analysis. For this reason it was decided to increase the reaction time and temperature of the system. In the subsequent experiment (entry 2) the first cycle was performed at 85 °C for 1 h; then a second cycle was performed for 10 min. at 85 °C using the concurrent heating and cooling system.¹⁴⁰ In the third cycle (85 °C, 1 h) 1 equivalent of ethylene glycol and 5 mol% of CuI were added to the reaction mixture to force the reaction to go to completion; then a fourth cycle was performed for 1 h increasing the reaction temperature from 85 °C up to 120 °C. Each cycle was checked by TLC analysis. The desired sulfide was obtained in 82% yield after filtration on silica gel and purification by column chromatography.

In an attempt to further optimize the reaction conditions, trying to improve the solubility of the starting materials in the solvent, it was decided to change the catalyst counter-anion and to run the reactions in the ionic liquid BMIM•BF₄ (1-butyl-3-methyl-imidazolium tetrafluoroborate, entries 3 and 4). Copper chloride was used instead of copper iodide in the following experiments (entries 3 and 4), using BMIM•BF₄ as solvent but only starting material was recovered at the end of the reactions, despite the fact that Cu(I) chloride should dissolve in solutions containing NEt₃ to give complexes (NEt₃ was used as base in entry 4), resulting in a better homogeneity of the reaction mixture.

Table 26. Results with model reaction^a

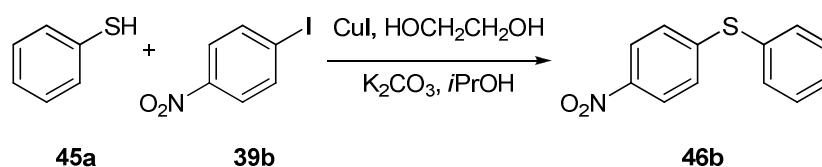

Entry	Reagents	Time [h]	Temp. [°C]	Result (yield [%]) ^b
1 ^c	CuI, K ₂ CO ₃ , <i>i</i> PrOH	2	85	46b (traces), 45a , 39b
2	CuI, K ₂ CO ₃ , <i>i</i> PrOH	3.1	85→120	46b 82 ^d
3 ^e	CuCl, BMIM•BF ₄	1	120	46b (traces), 45a , 39b
4	CuCl, NEt ₃ , BMIM•BF ₄	1.5	120	46b (traces), 45a , 39b

^a Reactions were carried out using **39b** (1 equiv) and **45a** (1 equiv) in the presence of a copper(I) source (5 mol%), ethylene glycol (2 equiv), a base (2 equiv) and *i*PrOH as solvent at 120 °C under anhydrous conditions;

^b Results were observed after ¹H NMR spectroscopic analysis of the crude reaction mixture; ^c Reaction was carried out in the presence of air; ^d Isolated yield after purification by column chromatography; ^e Reaction was carried out using 2 equiv of **39b** without base.

Given the success of the copper-mediated process in the presence of a glycol ligand, the next stage was the application of the method to the reaction between an aryl iodide with an electron-donating substituent and the simple thiophenol (**45a**). 4-Iodoanisole was chosen for this transformation to contrast its electronic properties with 4-iodobenzene. It was decided to run the reaction at 120 °C with 3 cycles of 1 hour each in a CEM Discover microwave system.

Table 27. Results obtained using 4-iodoanisole^a

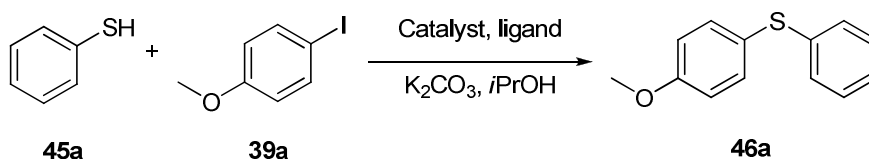

Entry	Reagents	Conditions	46a Yield [%] ^b
1	CuI, Ethylene glycol	3 h, 120 °C	89
2	CuCl, Ethylene glycol	3 h, 120 °C	19
3	CuI, Ethylene glycol	3 h, 130 °C	85
4 ^c	CuI, Ethylene glycol	3 h, 120 °C	84
5 ^d	CuI, <i>trans</i> -1,2-diaminocyclohexane	2 h, 120 °C	65

^a Reactions were carried out using **39a** (1 equiv) and **45a** (1 equiv) in the presence of a copper(I) source (5 mol%), ethylene glycol (2 equiv), K₂CO₃ (2 equiv), and *i*PrOH as solvent at 120 °C under anhydrous condition;

^b Isolated yield after purification by column chromatography; ^c Reaction was carried out in the presence of 4 equiv of ethylene glycol; ^d Reaction was carried out in the presence of 8 equiv of *trans*-1,2-diaminocyclohexane.

The desired sulfide **46a** was obtained in 89% yield after a simple filtration over silica gel and further purification by column chromatography (Table 27, entry 1). Further tests to optimize the reaction conditions were done: at first the catalyst was changed to copper chloride for a better solubility but this gave a poorer result (19%, entry 2) compared to the test reaction. Then the reaction temperature was increased to 130 °C but there was a slight decrease in the yield (85%, entry 3); subsequently the number of equivalents of the ligand was increased to 4 but no real improvement in the reaction outcome was gained (84% compared to 85%, entry 4). Finally, following Carril's work in 2007 on Cu-catalyzed *S*-arylation reactions in water (Scheme 95), it was decided to move from an acyclic ligand to a cyclic and more constrained one such as diaminocyclohexane.¹⁴²

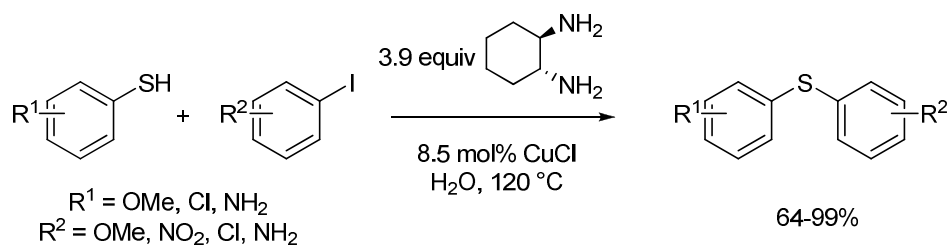

Scheme 95. Carril's C–S bond formation in water

In Carril's paper, the optimal reaction conditions for the target *S*-arylation reaction involved stirring both the iodobenzene and aromatic thiol in the presence of water at 120 °C, 8.5 mol% CuCl and 3.9 equivalents of *trans*-1,2-diaminocyclohexane. It was demonstrated that linear diamines led to less active catalysts than configurationally restricted ones but the reason for such catalyst activity enhancement is still not known. Our studies using microwave irradiation showed that after 2 hours of microwave heating, the desired sulfide was obtained in 65% yield (entry 5), which was lower than the test reaction but this result suggested the possibility of using a configurationally fixed diol as ligand for this kind of transformation. Thus, the reaction scheme was changed as follows:

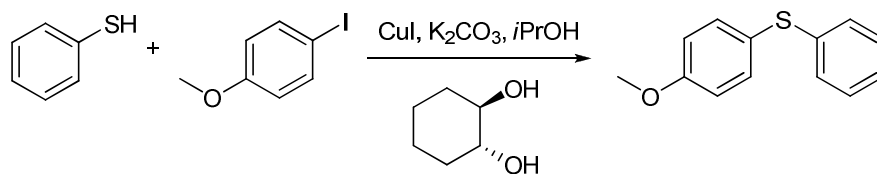

Scheme 96. Reaction with (\pm)-*trans*-1,2-cyclohexanediol

In our approach, thiophenol was reacted with 4-iodoanisole in the presence of 5 mol% of copper(I) iodide as catalyst, 2 equivalents of (\pm)-*trans*-1,2-cyclohexanediol as ligand, 2 equivalents of potassium carbonate as base at 120 °C for 3 hours under microwave irradiation. The desired sulfide was obtained in 95% yield after filtration on silica gel and purification by column chromatography (Table 28 entry 1). Optimization studies were carried out, which aimed to explore the susceptibility of the reaction to changes in the amount of ligand and catalyst. At first, the amount of ligand was decreased from 2 equivalents to 1.05 equivalents (with respect to reagents) and this gave a slight decrease in the yield (85%) (entry 2). The percentage of conversion to sulfide was lower with the decrease of ligand to 1 equivalent (85%, entry 3) or 5 mol% (70%, entry 4). This proved that for the best results, the right amount of ligand should have been 2 equivalents (with respect to reagents). Changing to *cis*-1,2-cyclohexanediol gave the desired sulfide but with a lower yield compared to the result in entry 1 (68%, entry 5). This was possibly an indication that the *trans*-ligand was able to form

a more active complex with the catalyst than the *cis*-one. A 64% yield of product was obtained in the absence of ligand in the reaction mixture (entry 6) and this proved that a ligand was not necessarily required to carry out this transformation. Furthermore, carrying out the reaction in the absence of the catalyst from the reaction mixture gave back just starting material (entry 7), evidence that, in any explanation of reaction mechanism, a catalytic process should be considered.

Table 28. Investigation on ligand^a

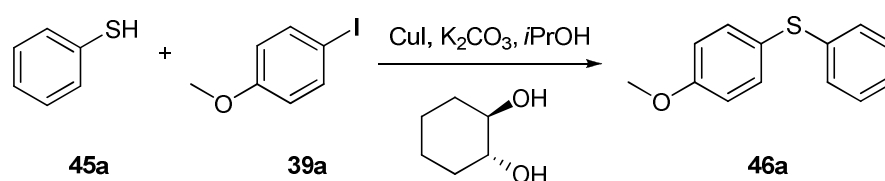

Entry	(±)- <i>trans</i> -1,2-Cyclohexanediol [equiv.]	46a Yield [%] ^b
1	2	95
2	1.05	88
3	1	85
4	0.05	70
5 ^c	2	68
6	–	64
7 ^d	2	–
8 ^e	2	85

^a Reactions were carried out using **39a** (1 equiv) and **45a** (1 equiv) in the presence of copper(I) iodide (5 mol%), (±)-*trans*-1,2-cyclohexanediol (2 equiv), K₂CO₃ (2 equiv), and *i*PrOH as solvent at 120 °C under anhydrous conditions; ^b Isolated yield after purification by column chromatography; ^c Reaction was carried out in the presence of 2 equiv of *cis*-1,2-cyclohexanediol; ^d Reaction was carried out without copper(I) iodide; ^e Reaction was carried out in the presence of silicon carbide passive heating elements.

Finally, the reaction was carried out using a silicon carbide (SiC) passive heating element present (see Introduction, paragraph 1.1.2), in order to explore the possibility of non-thermal or specific microwave effects in the reaction medium (entry 8). These effects are defined as “accelerations of chemical transformations in a microwave field that can not be achieved or duplicated by conventional heating, but essentially are still thermal effects” (as reported by Kappe in 2009).^{1a}

From the outcome, it was not possible to determine any real influence on the reactivity from specific microwave effects, even if the heating profile was not as steady and continuous as the one for the reaction without a passive heating element. This was probably due to the fact that

the SiC elements did not release the microwave energy steadily but caused some bursts, resulting in a heating profile as in Figure 27.

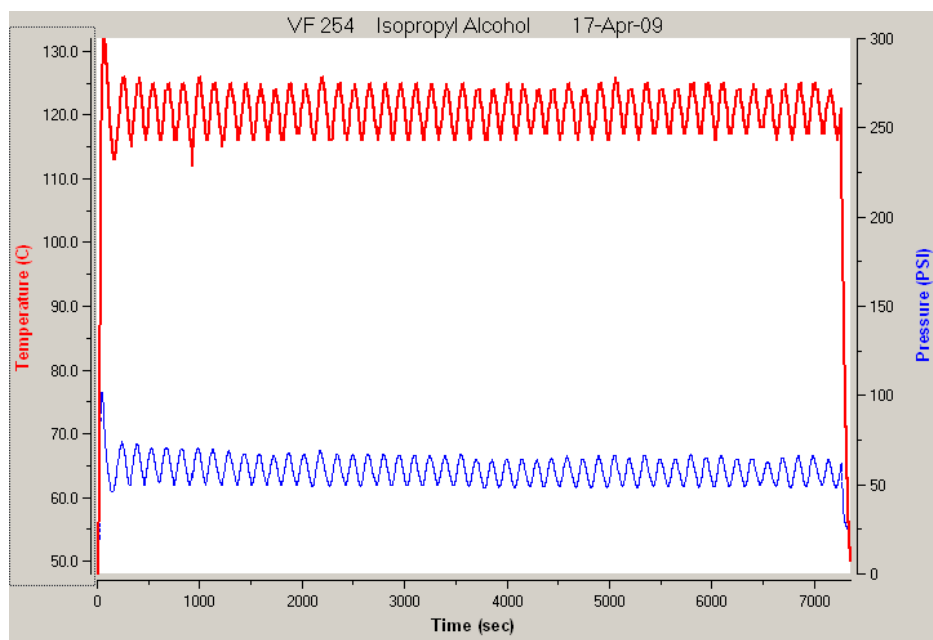
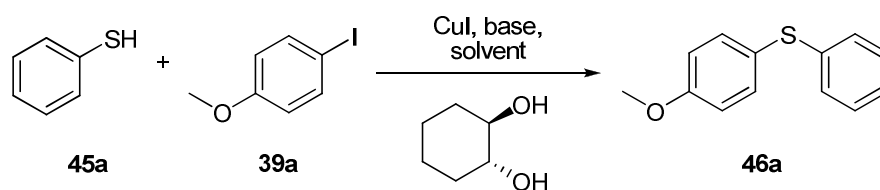

Figure 27. Temperature/pressure reaction profile

Efforts to optimize the reaction were next investigated by varying the base and solvent (Table 29). An attempt to carry out the reaction in water was only poorly successful, giving the desired product in 31% yield (Table 29, entry 1). This could be explained as a miscibility issue. It was demonstrated, in fact, that by changing the base from potassium carbonate to triethylamine, the solubility of the starting materials increased so as to afford a homogeneous mixture before the reaction. This study was carried out with the aim to move towards a continuous flow process and, in order to conduct this type of experiment, the homogeneity of the starting materials must be maintained (see Introduction, paragraph 1.3.2).

Table 29. Optimization study using different bases and solvents^a

Entry	Base-Solvent	Conditions	46a Yield [%] ^b
1	K ₂ CO ₃ , H ₂ O	3 h, 120 °C	31
2	NEt ₃ , <i>i</i> PrOH	3 h, 120 °C	60
3	NEt ₃ , <i>i</i> PrOH	1.5 h, 120 °C	45
4	NEt ₃ , <i>i</i> PrOH	45 min, 120 °C	58
5 ^c	K ₂ CO ₃ , <i>i</i> PrOH	4 d, 120 °C	81
6 ^c	K ₂ CO ₃ , <i>i</i> PrOH	24 h, 110 °C	84

^a Reactions were carried out using **39a** (1 equiv) and **45a** (1 equiv) in the presence of copper(I) iodide (5 mol%), (±)-*trans*-1,2-cyclohexanediol (2 equiv), K₂CO₃ (2 equiv), and *i*PrOH as solvent at 120 °C (150 W) under anhydrous conditions; ^b Isolated yield after purification by column chromatography; ^c Reaction was carried out at reflux under an anhydrous atmosphere using conventional heating.

Subsequently, the reaction was performed for 3 hours at 120 °C changing just the base and this gave the sulfide in 60% yield after purification by column chromatography (Table 29, entry 2). In the following experiments (entries 3 and 4) the reaction time was reduced to study the reaction outcome: first, the time was reduced to 1.5 hours (entry 3) and there was a slight decrease in the yield compared to the 3 hours reaction (45 instead of 60%). Then, the reaction time was reduced to 45 min (entry 4) and the yield was comparable to the 3 hour experiment (58 instead of 60%). This result showed that the reaction was transferable to continuous flow mode for this type of substrate and the next step could have been the actual reaction using the flow tube apparatus with the CEM Discover[®].

A comparison between microwave heating and conventional heating was necessary to understand the validity of an alternative heating source. For this reason, the reaction was carried out at reflux for 4 days at 110 °C using a Schlenk apparatus to ensure an anhydrous atmosphere in the reaction medium (entry 5). The desired product was obtained in 81% yield. Carrying out the same reaction for one day instead of four days (entry 6) gave a slight increase in the reaction yield (84 in the place of 81%). Overall, the conventional heating was efficient but not as convenient as the microwave mediated process, which was able to reduce the reaction time to 3 hours with advantages even in terms of purification (less starting material present at the end of the reaction).

In order to explore the scope of the optimised microwave-assisted procedure, a range of both electron-rich and electron-poor aryl halides were reacted in turn with a selection of thiols (Table 30).

Table 30. Expanding the methodology to different substrates^a

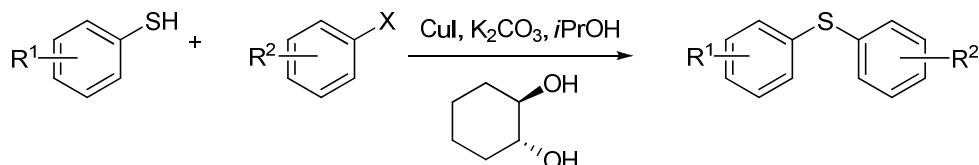

Entry	Halide	39	ArSH	45	Product	46	Yield [%] ^b
1		d		a		d	91
2		e		a		c	86
3		c		a		c	32
4		f		a		c	–
5		g		a		e	76
6		b		a		b	81
7		h		a		b	74
8		a		c		f	48
9 ^c		b		c		fa	64

^a Reactions were carried out using aryl halide **39** (1 equiv) and thiol **45** (1 equiv) in the presence of copper(I) iodide (5 mol%), (\pm)-*trans*-1,2-cyclohexanediol (2 equiv), K₂CO₃ (2 equiv), and *i*PrOH as solvent at 120 °C under anhydrous conditions; ^b Isolated yield after purification by column chromatography; ^c Reaction was carried out by Bethany Stephens.

In general, the reaction gave very good yields and was highly successful for iodides and certain bromides. Usually bromides reacted more slowly compared to iodides (Table 30, entries 3 and 7). The methodology was not effective when aryl chlorides were used (entry 4).

An alkyl thiol (**45c**) was used as an alternative to aryl thiols, with some reduction in efficiency (entries 8 and 9). When steric hindrance was introduced in to the halide or alternatively in the thiol, the reactivity was not affected (Table 31).

Table 31. Expanding the methodology to different substrates^a

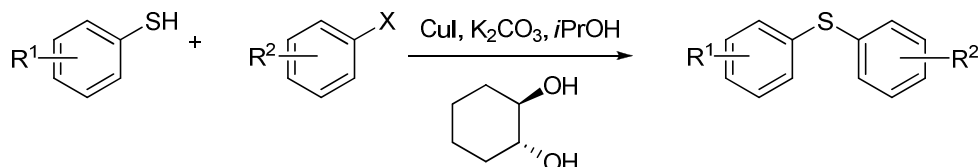

Entry	Halide 39	ArSH 45	Product 46	Yield [%] ^b
1				95
2				85
3				78
4 ^c				94
5 ^c				81
6				75
7				79
8				66

^a Reactions were carried out using aryl halide **39** (1 equiv) and thiol **45** (1 equiv) in the presence of copper(I) iodide (5 mol%), (\pm)-*trans*-1,2-cyclohexanediol (2 equiv), K₂CO₃ (2 equiv), and *i*PrOH as solvent at 120 °C under anhydrous conditions; ^b Isolated yield after purification by column chromatography; ^c Reaction was carried out using 2 equiv of thiol **45a**.

Initially 2-iodoanisole **39i** was reacted with thiophenol **45a**, giving the desired sulfide **46g** in a very good yield (95%, Table 31, entry 1). A further grade of complexity was introduced using halide **39j** and thiol **45b** where the reactivity was slightly affected (85 and 78%, entries 2 and 3). The simultaneous formation of two C–S bonds could be facilitated in excellent yield (94 and 81%, entries 4 and 5) using dihalobenzene substrates **39k** and **39l**. In the subsequent examples, the sterically hindered thiol **45d** was reacted with 2 different halides with different electronic requirements, but similar results were obtained (75 and 79%, entries 6 and 7). Finally, the sterically hindered iodide **39m** was reacted with the simple thiophenol **45a**, obtaining the desired compound **46m** in a good yield (66%, entry 8).

A series of thiols was then chosen to be reacted with two iodides, **39a** and **39b**, bearing groups with different electronic requirements to test if any effects on the reactivity were observed (Table 32).

Table 32. Expanding the methodology to different substrates^a

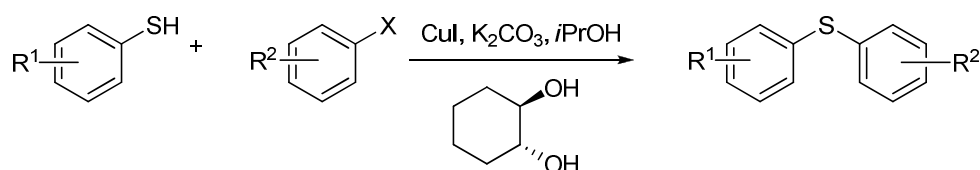

Entry	Halide	39	ArSH	45	Product	46	Yield [%] ^b
1 ^c		a		e		n	91
2 ^c		b		e		o	78
3 ^c		a		f		p	74
4 ^c		b		f		q	68
5		a		g		r	99
6 ^c		b		g		s	13
7 ^c		a		h		t	83

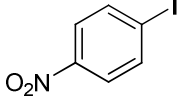
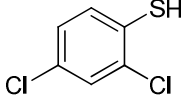
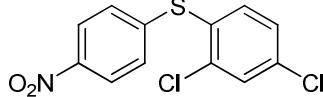
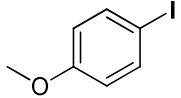
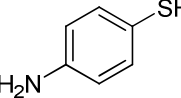
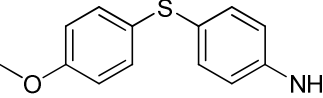
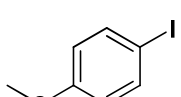
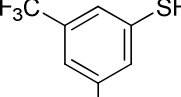
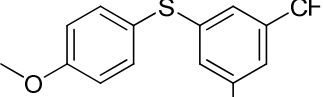
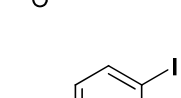
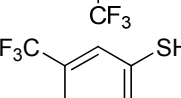
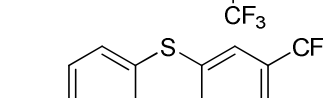
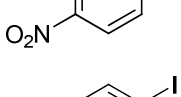
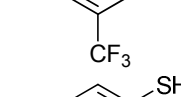
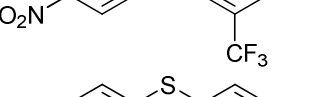
8 ^c		b		h		u	37
9 ^c		a		i		v	38
10 ^c		a		j		w	82
11 ^c		b		j		x	87
12 ^c		b		k		z	75

^a Reactions were carried out using arylhalide **39** (1 equiv) and thiol **45** (1 equiv) in the presence of copper(I) iodide (5 mol%), (\pm)-*trans*-1,2-cyclohexanediol (2 equiv), K₂CO₃ (2 equiv), and *i*PrOH as solvent at 120 °C under anhydrous condition; ^b Isolated yield after purification by column chromatography; ^c Reaction was carried out by Bethany Stephens.

In general no dependence of reactivity upon the electronic nature of the substrates was observed, giving rise to the conclusion that the actual catalytic cycle that operates for this type of transformation could well be the σ -bond metathesis, illustrated previously (see Discussion, paragraph 3.1.1). In some cases it was not possible to explain the low reactivity by consideration of electronic effects alone (Table 32, entries 6 and 8) in a single mechanism. The chemoselectivity of the process was showed to be highly selective towards the formation of the C–S bond rather than C–O or C–N bonds (entries 3, 4 and 9), even if the overall efficiency was lower in some cases (entry 9).

3.2.3 Conclusions

A new catalytic method that uses Cu(I) iodide as catalyst and (\pm)-*trans*-1,2-cyclohexanediol as ligand has been established for the microwave mediated C–S bond formation. The methodology has been applied to the synthesis of aryl sulfides of varying complexity and different electronic requirements. Considering the mechanistic cycles proposed for this transformation (see Discussion, paragraph 3.2.1) and the results which show no dependence of reactivity upon the electronic nature of the substrates, it would be possible to speculate that a σ -bond metathesis mechanism does indeed take place. Further experiments to elucidate and

confirm the real nature of the mechanism will need to be carried out and are part of the future work.

3.3 Application to the synthesis of VX 745

Our work on the application of microwave technology to Ullmann-type coupling found application in the synthesis of a candidate for the treatment of a premature ageing disorder called Werner syndrome.

3.3.1 Introduction

P38 α is one member of the mitogen-activated protein kinase (MAPK) family of intracellular enzymes, which also includes ERKs (extracellular signal regulated kinases) and JNKs (c-Jun amino terminal kinases). It is part of a cell signalling cascade involved in the regulation of pro-inflammatory cytokine biosynthesis at the transcriptional and translational level.¹⁴³ Inhibition in the production of these cytokines could be a useful therapeutic strategy to suppress inflammation in different diseases such as rheumatoid arthritis, Crohn's disease, psoriasis and Werner Syndrome (WS). Small molecule p38 inhibitors are targeted as potential therapeutic agents for the treatment of these inflammatory diseases.^{143a,143c,144}

Werner Syndrome is a very rare autosomal recessive disorder (Figure 28) that affects connective tissue throughout the body.

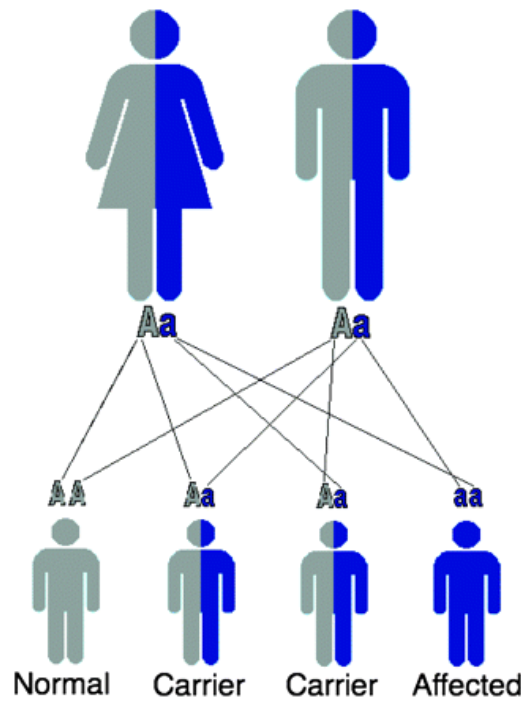

Figure 28. Mechanism of recessive inheritance¹⁴⁵

This entity is caused by a mutation at the WS gene (*WRN*) locus, located on the short arm of the 8th chromosome, which belongs to the family of *RecQ* helicases. Werner Syndrome is caused by a helicase defect and as a result DNA replication is impaired (Figure 29).

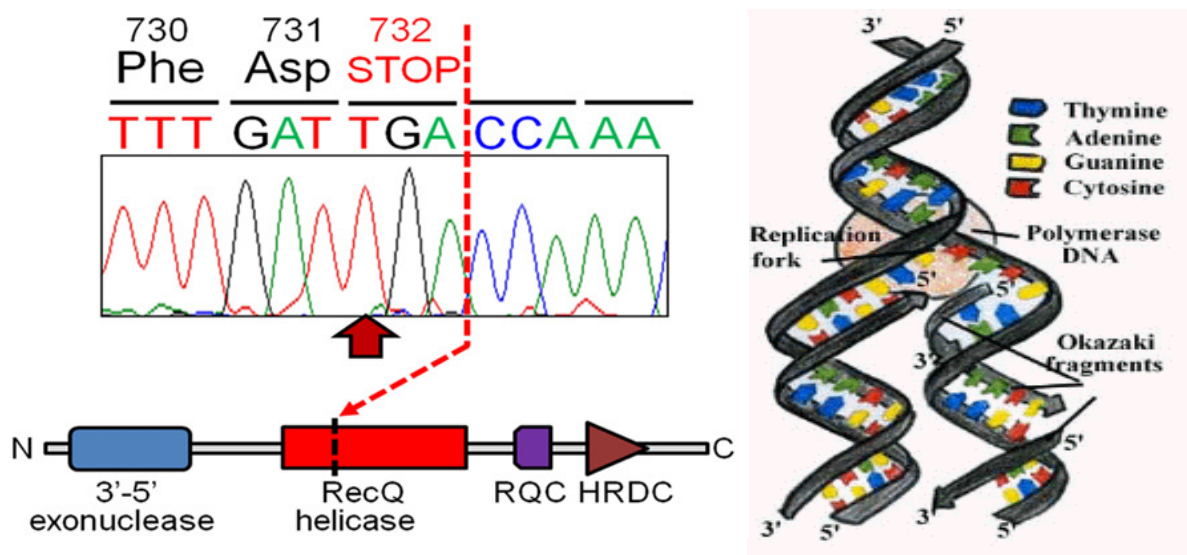

Figure 29. Defect in DNA repair as a consequence of deficiency in the *WRN* protein¹⁴⁶

WS is characterized by the appearance of premature ageing. Individuals affected by WS, typically develop normally until puberty. Following puberty they age rapidly with a median life expectancy of about 47 years. The earliest sign is the lack of a teenage growth spurt, which results in short stature. Others symptoms appear when they are in their twenties or

thirties and include loss and graying of hair, hoarseness of the voice, thickening of the skin, and cataracts in both eyes. Overall, people affected by WS have thin arms and legs and a thick torso. They have a characteristic facial appearance described as "bird-like" when they are in their thirties. Patients with WS also exhibit genomic instability, hypogonadism and various age-associated disorders like cancer, heart disease, atherosclerosis and diabetes.

Specific treatment does not exist. Only symptomatic treatment of related disturbances is recommended. WS is widely used as a model disease to investigate normal human ageing processes.

Recent studies towards therapeutic intervention in this premature ageing disorder identified that blocking the p38 α response through the use of p38 α MAPK inhibitors can rescue the pathology of WS cells.

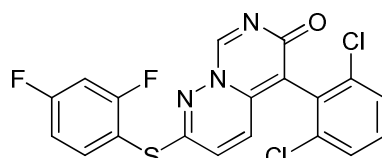

VX-745 (**48b**)

In 1999 Vertex Pharmaceuticals released the structure of a new clinical candidate, VX-745 (**48b**) that functioned by ATP competitive inhibition of p38 α MAPK.¹⁴⁷ This compound displayed potent activity, clinical efficacy and an exquisite selectivity profile, effective at 5.0 nM concentration with 1000-fold selectivity over closely related kinases, including ERK1, JNK1–3 and MK2. This profile, in particular the high selectivity for p38 MAPKs over JNKs, made the evaluation of VX-745 (**48b**) in WS cells compelling and so our group set out to realize the synthesis of this inhibitor to facilitate its biological study.

3.3.2 Results and Discussion

Although the synthesis of VX-745 has been described in the literature, the efficiency of some of the steps is very low and the methods have been reported to be poorly reproducible by Bemis (Scheme 97).^{147a-d}

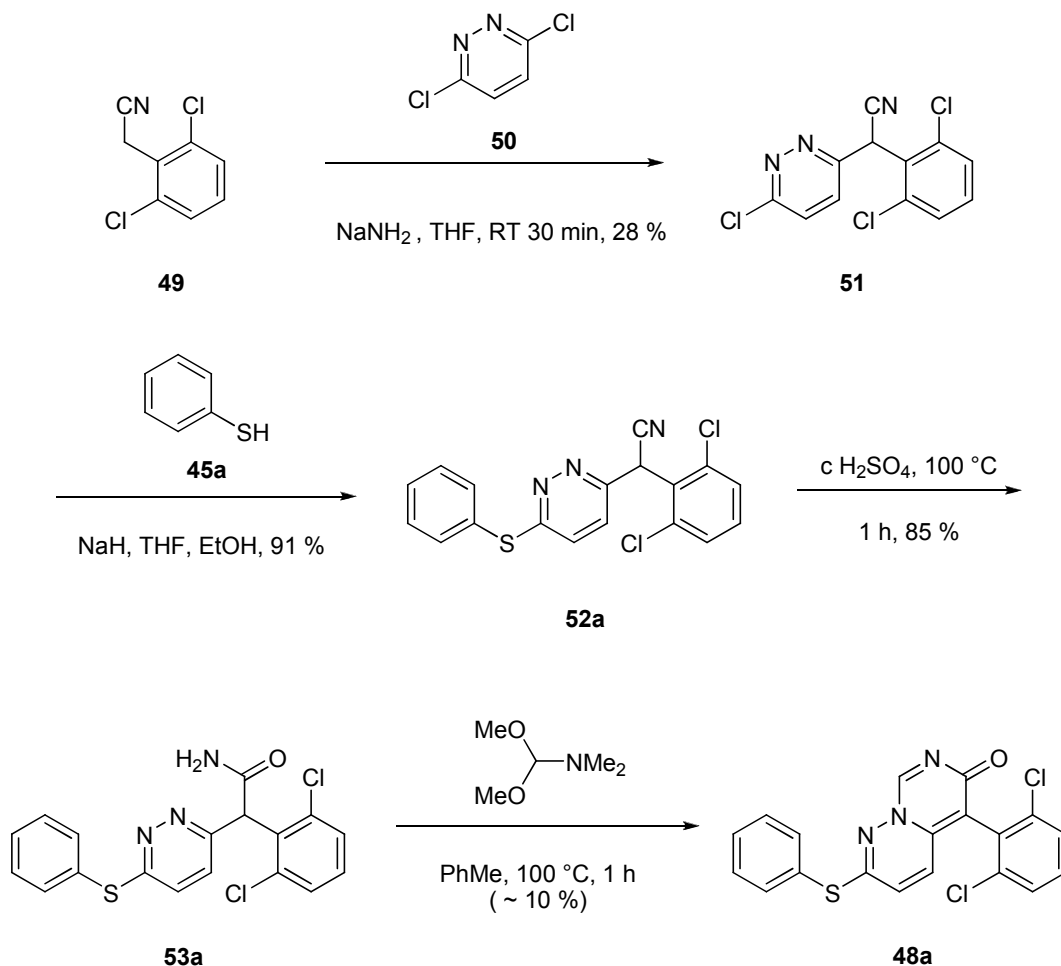

Scheme 97. Synthesis of an analogue of VX-745 (**48a**)

An improved procedure for the synthesis of analogues of VX-745 was reported in 2001 in the literature by Treu and coworkers.¹⁴⁸ The use of NaH in DMF instead of sodium amide, for the deprotonation of dichlorophenylacetonitrile **49** afforded a red solid with a yield of 43% instead of the 28% previously reported. However, the yield reported for the second step, using sodium hydride in DMF, was lower (75%). For the third step, Bemis reported the formation of an oil in 85% yield, contrary to Treu who obtained an orange solid after trituration in 64% yield. Finally, heterocyclization to the pyrazinopyrimidine was carried out under the same conditions as in the previous paper, using anhydrous toluene, for 2 h with 41% yield.

Our approach¹⁴⁹ (Scheme 98) to the pyrimido[1,6-*b*]pyridazinone motif was mindful of the limitations recorded in the original release,¹⁴⁷ in particular regarding the formation of the S-heteroaryl bond.^{148, 150}

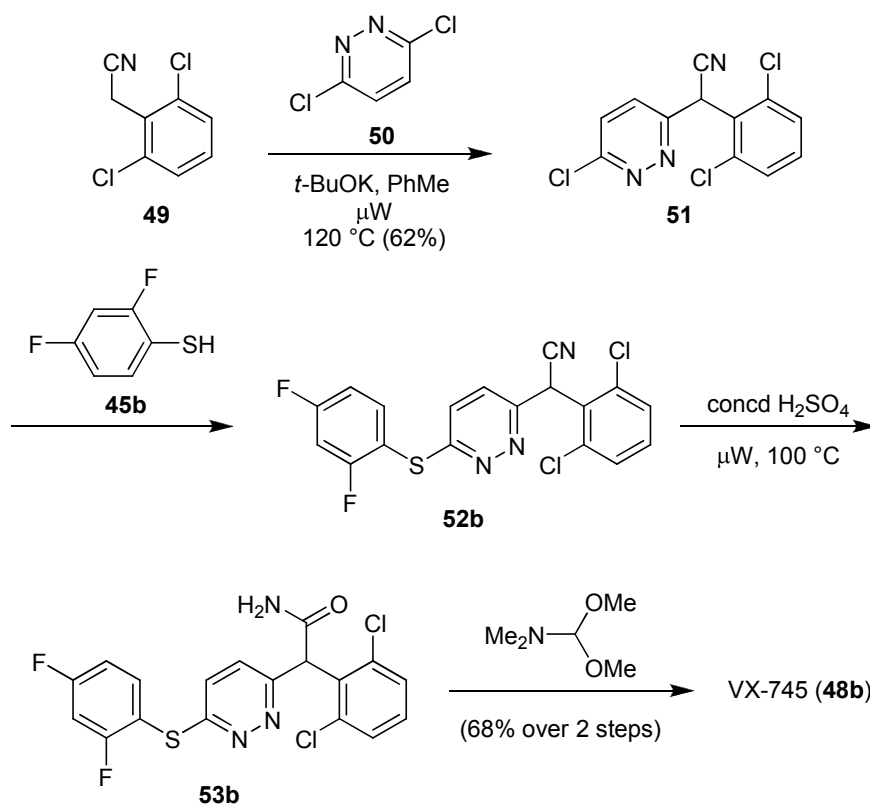

Scheme 98. Synthesis of VX-745 (**48b**)

In addressing these difficulties, it was hoped that our new microwave-mediated method for sulfide formation could be used for a rapid, efficient and readily automated synthesis of analogues. Thus the unusual central heterocyclic motif would be prepared by heteroannulation of a (phenylthio)pyridazine, prepared ultimately from 3,6-dichloropyridazine (**50**) by an Ullmann-type coupling with 2,4-difluorothiophenol that was facilitated by microwave irradiation (Scheme 99).

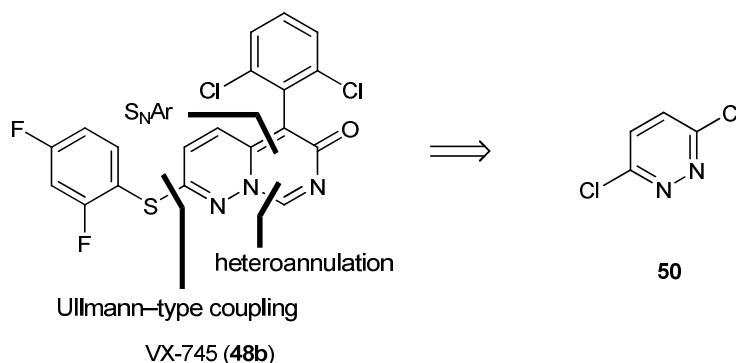

Scheme 99. Disconnection Strategy for the Synthesis of VX-745

desired disulfide was obtained in 64% yield after purification by column chromatography (entry 3). This result was poorer than the previous one performed using the PEPPSI-*i*Pr precatalyst but still gave the desired product in an appreciable yield. In the case of reaction using cyclohexanediol as ligand, the reaction gave a poor yield (35%, entry 4) compared to the previous experiments. Not so surprisingly, in the absence of catalyst and ligand, the reaction gave the disulfide **54** in a very good yield (79%, entry 5). The reaction was performed in presence of 1.5 equiv of sodium *tert*-butoxide in toluene at 120 °C for 3 h under microwave irradiation. This result, due to the nature of the substrate **50** (as discussed before in the paragraph), showed that the reaction could work mainly by a classical S_NAr reaction/pathway but the application of metal catalyzed methods could have an effect, as highlighted from the result in entry 2. These findings were then transferred to the step 2 of Scheme 98: the intermediate **51** was reacted with 2,4-difluorothiophenol **45b** exploring a range of conditions using conventional heating and microwave-mediated processes. Previous work within Bagley group is reported in Table 34, containing various results from the application of a range of conventional heating methods found in the literature.

Table 34. Reactions conducted with conventional heating^a (result from previous work carried out by Dr. Matt Dix).¹⁴⁹

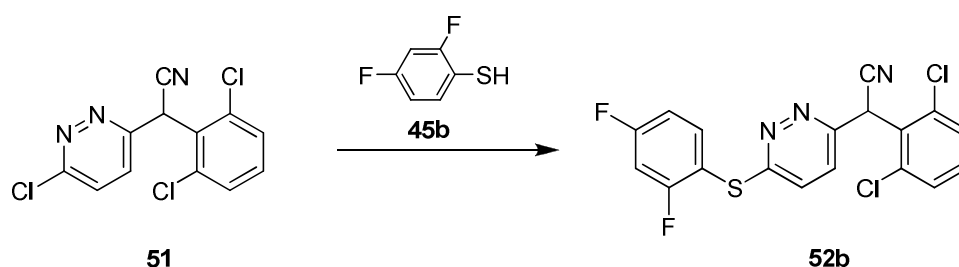

Entry	Reagents and Conditions	52b Yield [%] ^b
1	NaH, DMF, r.t., 3 h	57
2	Pd(OAc) ₂ (5 mol%), NaO <i>t</i> Bu (1.1 equiv), DPPF (10 mol%), PhMe, reflux, 16 h	31
3	Pd(OAc) ₂ (5 mol%), NaO <i>t</i> Bu (1 equiv), (S)-TolBINAP ^c (10 mol%), PhMe, reflux, 16 h	73
4	PEPPSI TM - <i>i</i> Pr (2 mol%), NaO <i>t</i> Bu (1 equiv), PhMe, reflux, 18 h	75
5	CuI (10 mol%), NEt ₃ , dioxane, 90 °C, 16 h	82

^a Reactions were conducted under conventional heating using the selected catalyst and base reported; ^b Isolated yield after purification by column chromatography; ^c (S)-TolBINAP = (S)-(-)-2,2'-bis(di-*p*-tolylphosphino)-1,1'-binaphthyl.

A simple S_NAr reaction was performed initially: the reaction was conducted at room temperature for 3 h in presence of sodium hydride in DMF, obtaining the desired compound **52b** in a reasonable yield (57%, Table 34, entry 1) but after a complicated purification due to the presence of unreacted starting materials. Traditional conductive heating methods using a Pd or Cu catalyst were considered: two reactions were then performed using palladium acetate in presence of a phosphine ligand, sodium *tert*-butoxide as base in toluene, heating at reflux for 16 h in both cases. The desired compound was obtained in 31 and 73%, respectively (Table 34, entries 2 and 3). The second result was comparable to the one obtained using the catalyst PEPPSI (75%, Table 34, entry 4). Finally, the reaction was performed in the presence of copper iodide as catalyst (10 mol%) using triethylamine as base in dioxane, heating at 90 °C for 16 h: the desired sulfide was obtained in 82% yield after purification by column chromatography (Table 34, entry 5). From these experiments it could be seen that the application of a metal catalyzed process to this transformation proved effective in its ability of providing the desired product in a better yield compared to the reaction in which a simple S_NAr mechanism was operating (Table 34, entry 1). At this stage, as part of this study, the long reaction time was the problem to address and, for this reason, the use of microwave irradiation was thought to be the right solution, in order to simplify the purification procedure and provide rapid access to sulfide **52b** for elaboration to VX-745.

In Table 35, a range of methods were explored for C–S bond formation, with facility for scale-up, under microwave irradiation.

Table 35. Explored range of microwave-mediated reactions.^a

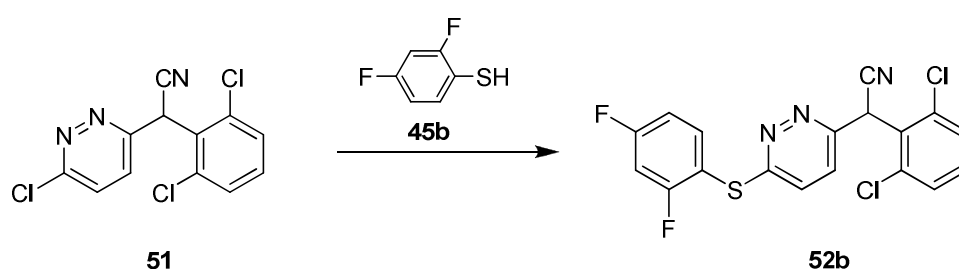

Entry	Reagents and Conditions	52b Yield [%] ^b
1	Pd(OAc) ₂ , (5mol%), XantPhos (2 equiv), NaOtBu (2 equiv), PhMe, 150 °C	44
2 ^c	CuI (10 mol%), NEt ₃ , dioxane, 100 °C	24
3	PEPPSI TM - <i>i</i> Pr (2 mol%), NaOtBu (1.5 equiv), PhMe, 150 °C (120 W), 1 h	75
4	PEPPSI TM - <i>i</i> Pr (2 mol%), NaOtBu (1.5 equiv), LiCl (20 mol%), PhMe	72

5	NaOtBu (1.5 equiv), PhMe, 150 °C (120 W), 1 h	54
6	NaOtBu (2 equiv), PhMe	69
7	CuI (10 mol%), neocuproine (10 mol%), NaOtBu (1.5 equiv), PhMe	79
8	Neocuproine (10 mol%), NaOtBu (1.5 equiv), PhMe	86

^a Reactions were carried out using **51** (1 equiv), **45b** (1.1 equiv) in the presence of the selected catalyst, ligand and base in toluene (2 mL) for 3 hours at 120 °C in a sealed tube using a CEM[®] discover single-mode microwave synthesizer by moderation of the initial magnetron power (150 W), unless otherwise stated; ^b Isolated yield after purification by column chromatography; ^c Reaction was carried out by Dr. Matt Dix.

From the first experiments it was possible to directly compare the two conventional heating methods using a palladium or copper catalyst (from Table 34) to those carried out under microwave heating. In the first experiment, 5 mol% of palladium acetate and XantPhos (2 equiv) as ligand in the presence of sodium *tert*-butoxide as base in dioxane were used. The sulfide **52b** was obtained in 44% yield (Table 35, entry 1), a result that was not as good as the best conventional heating palladium mediated method, even if not directly comparable with entries 2 and 3 of Table 34 because a different ligand had been used. Instead, an exact repetition of entry 5, Table 34 gave a poorer result: carrying out the reaction at 100 °C for 3 h under microwave irradiation in presence of copper iodide (10 mol%) and triethylamine in toluene gave the sulfide **52b** in 24% yield (Table 35, entry 2). At this stage, the use of PEPPSITM-*i*Pr and the CuI/neocuproine method was taken into consideration. The reaction was performed at 150 °C under microwave heating for 1 h, using 2 mol% of PEPPSITM-*i*Pr with sodium *tert*-butoxide as base in toluene. The desired sulfide was obtained in a very good yield (75%, entry 3) after purification by column chromatography. It is worth mentioning that carrying out the same reaction in the absence of the catalyst also gave the sulfide, but in a lower yield (54%, entry 5), probably due to the shorter reaction time. A decrease in the temperature (120 °C from 150 °C) with a simultaneous increase in the reaction time (from 1 h up to 3 h) in presence of an additive such as lithium chloride (20 mol%), previously reported to be used in this type of transformation (see Discussion, paragraph 3.1.3), gave a result comparable to entry 3 (72%, entry 4). Even in this case, carrying out the reaction in the absence of the catalyst afforded the product in a lower but “closer” yield (69%, entry 6). Probably this last result was due to the increase in the reaction time.

Addition of neocuproine was then considered: the reaction was performed using 10 mol% of copper(I) iodide and 10 mol% of neocuproine in the presence of sodium *tert*-butoxide (2 equivalents) in toluene at 120 °C for 3 h under microwave heating. The intermediate **52b** was obtained in a very good yield (79%, entry 7), a result that is in line with the model studies (see

Discussion, paragraph 3.1.3). Even more surprisingly, removal of the catalyst afforded the desired sulfide in a higher yield (86% compared to 79%, entry 8), probably due to a coordination effect of the ligand with the nucleophile.

Overall, the use of microwave irradiation proved particularly effective for this C–S bond formation with shorter reaction times than traditional conditions and less impurities found during the purification procedures. However, the best results were found using a copper(I) catalyst and (\pm)-*trans*-cyclohexane-1,2-diol as ligand in the presence of potassium carbonate in 2-propanol (Table 36).

Table 36. Results with our catalytic system^a

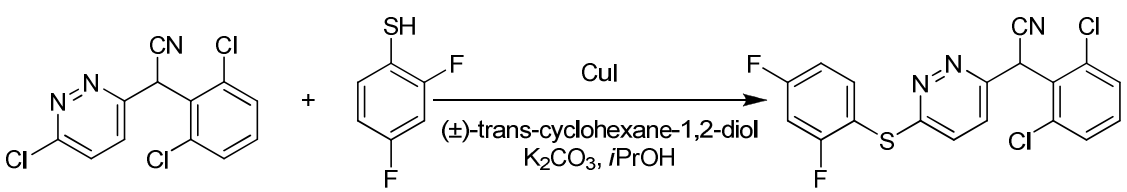

Entry	Catalyst [mol%]	Ligand [equiv]	52b Yield [%] ^b
1	5	2	91
2	–	2	95
3	–	–	63
4 ^c	5	2	94
5 ^c	–	2	88

^a Reactions were carried out using **51** (1 equiv), **45b** (1.1 equiv), CuI (5 mol%), (\pm)-*trans*-1,2-cyclohexanediol (2 equiv), K₂CO₃ (2 equiv) in *i*-PrOH under microwave dielectric heating for 3 h at 120 °C (initial power 150 W) under anhydrous conditions in a sealed tube using a CEM Discover[®] single-mode microwave synthesizer; ^b Isolated yield after purification by column chromatography; ^c Reaction was carried out by Morgane Pigeaux on 1 gram of **51** (3.38 mmol) using a CEM Voyager[®] platform on the Discover[®] single-mode microwave synthesizer.

In the first attempt, the product **52b** was obtained in 91% yield (Table 36, entry 1), a result that was to be expected given our previous findings using this methodology. Even in this case, removal of the catalyst gave the desired sulfide in a slightly improved yield (95%, entry 2). Further investigation was carried out by removing the ligand: the reaction was performed in presence of two equivalents of potassium carbonate in isopropanol and the product was obtained in a lower yield (63%, entry 3) compared to the previous two entries.

Increasing the scale, the use of copper seems to have had a slight influence on the yield, 94% against 88% without the catalyst (entries 4 and 5). The scale-up was performed using one

gram of starting material under the same reaction conditions as entry 1 by irradiation using a CEM Voyager[®] platform.

3.3.3 Conclusions

The application of microwave irradiation to the synthesis of VX-745 has proven to be very effective in shortening the reaction times and increasing the reaction yields. Considering the substrate used, it was unquestionable that the transformation was predominantly a classical S_NAr process.

However, in order to increase the yield to its maximum, metal catalyzed processes had to be taken into consideration. Among all of the methods tried, the conditions previously developed for C–S bond formation, using copper(I) catalyst in presence of a cyclic diol as ligand (see Discussion, paragraph 3.2), proved to be the best to obtain the product **52b** in very good yield (Table 36, entry 1), even if, without catalyst, **52b** was obtained in a slightly better yield (Table 36, entry 2). Moreover, scale-up of the reaction was carried out efficiently, showing that these parameters transfer well between a microwave batch process and a stop-flow microwave reactor, as reported in Table 36, entries 4 and 5.

3.4 Application to the synthesis of anti-HIV compounds

3.4.1 Introduction

AIDS, caused by the human immunodeficiency virus (HIV), is still a health threat of global significance. There are currently more than 30 drugs approved for the treatment of HIV-infected individuals (as reported by F.D.A. at the beginning of 2010),¹⁵² targeting different inhibitors: nucleoside reverse transcriptase (NRTI), non-nucleoside reverse transcriptase (NNRTI), acyclic nucleoside phosphonate reverse transcriptase (RT), protease (PIs), integrase and “fusion”. Protease inhibitors target the activity of the enzyme responsible for the cleavage of new proteins responsible for the assembly of new virions. Integrase inhibitors target the enzyme responsible for the integration of viral DNA into human DNA. “Fusion” inhibitors

interfere during the process of entry of HIV type 1 (HIV-1) to the host cell. NRTI and NNRTIs inhibit both the reverse transcriptase by two different mechanisms: NRTI blocks the elongation of newly synthesized viral DNA by inserting in it. NNRTIs on the other side bind to the enzyme next to its active site (Figure 30).¹⁵³

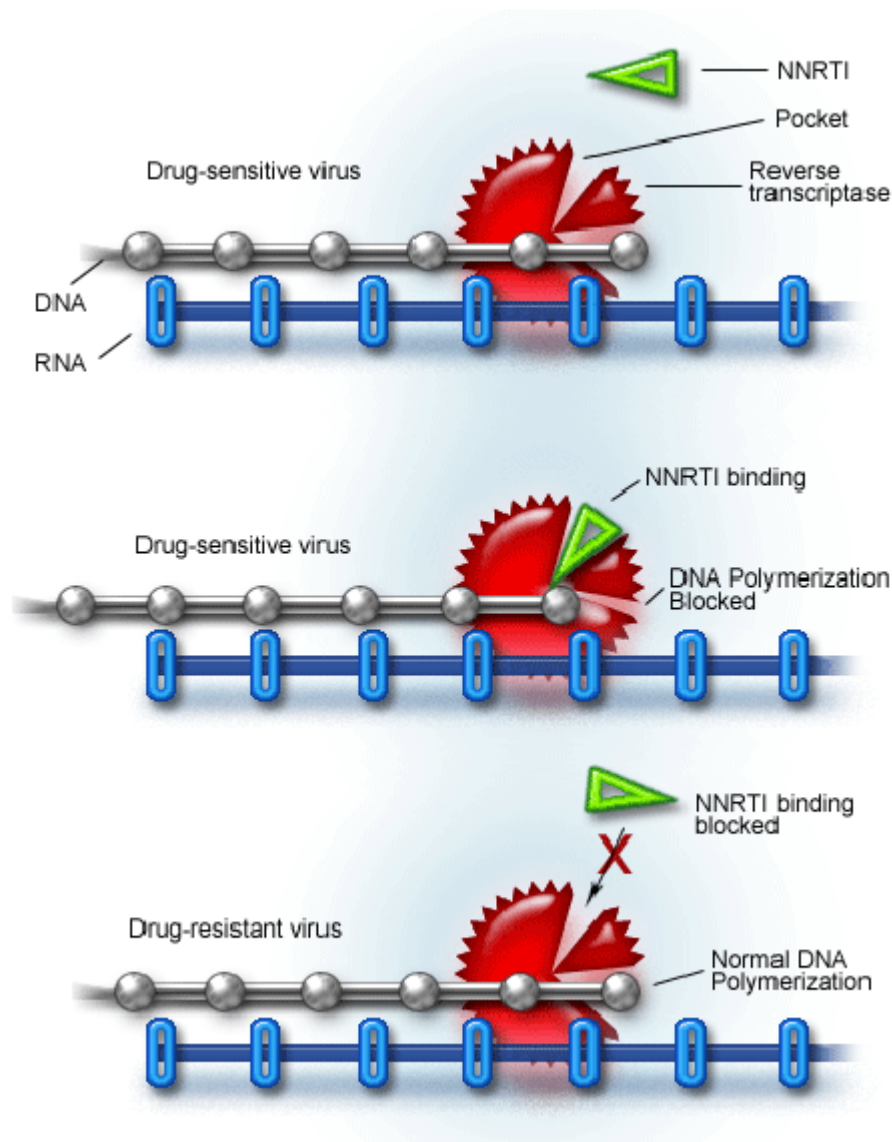
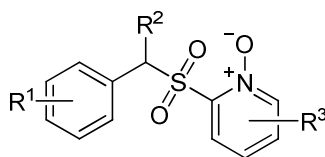

Figure 30. Mechanism of NNRTI activity and HIV NNRTI resistance¹⁵³

A major drawback of this class of anti-HIV compounds, however, is the rapid emergence of drug-resistant virus strains, resulting in cross-resistance to other NNRTIs. HIV-1 resistance to NNRTIs has shown to be mediated through mutations of amino acid residues lining a hydrophobic NNRTI-binding pocket, located in the palm domain of the p66 subunit of RT. Because of the limitation of currently available anti-HIV drugs, an extensive search for new anti-HIV agents is still necessary and ongoing. The discovery and structure-activity

relationship of a group of pyridine oxide derivatives has been recently reported in the literature that are endowed with pronounced anti-HIV properties in cell culture (Figure 31).¹⁵⁴



R¹ = Alkyl, alkyloxy, cyano, nitro, aryloxy, benzyloxy.
 R² = Alkyl, halogen, cyano, aryl, benzyl, carboxamide.
 R³ = Alkyl, alkyloxy, halogen, hydroxy, cyano, nitro, benzyloxy.

Figure 31. New class of anti-HIV compounds

It was found that a number of them were very selective in inhibiting HIV-1 but not HIV-2. Other pyridine oxide derivatives, however, were also inhibitory to HIV-2, presumably through another mechanism of action.

It was felt that application of the new microwave-mediated C–S bond forming methodologies, for the rapid and efficient synthesis of 2-thiopyridines, could be extended to the synthesis of this class of anti-HIV drugs following the disconnection approach proposed in Scheme 100. Initial coupling between the thiol and the 2-halopyridine would then be followed by simultaneous oxidation of the nitrogen and sulfur to give the desired compound.

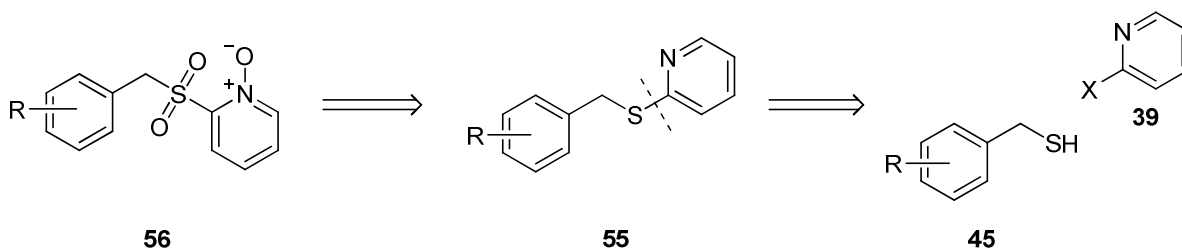

Scheme 100. Disconnection approach to molecule 56

3.4.2 Results and Discussion

It was decided to test our methodology for the C–S bond formation, in this case, in conjunction with a new strategy that makes use of copper nanoparticles in presence of a base and DMF as solvent (Scheme 101).¹⁵⁵ This recently reported methodology attracted our attention because it afforded the desired sulfides in surprisingly short reaction times (5 to 7 minutes) under microwave irradiation.

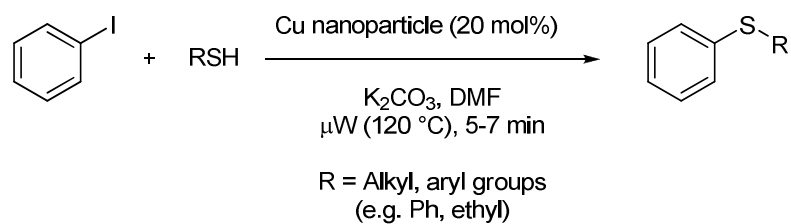

Scheme 101. Cu nanoparticle catalyzed C–S bond forming reaction

For the initial studies it was decided to use either a benzylthiol or a 2-mercaptopyridine as the thiol component and either a 2-halopyridine or 2,5-dimethylbenzylchloride as the halide. The reactions were carried out using copper nanopowder (50 nm size, 20 mol%, commercially available from Sigma Aldrich™) in the presence of potassium carbonate as base and DMF as solvent, increasing reaction times from 1.5 to 2 hours (considering the previous investigation on C–S bond forming reactions) (Table 37).

Table 37. Formation of the desired compounds **55**^a

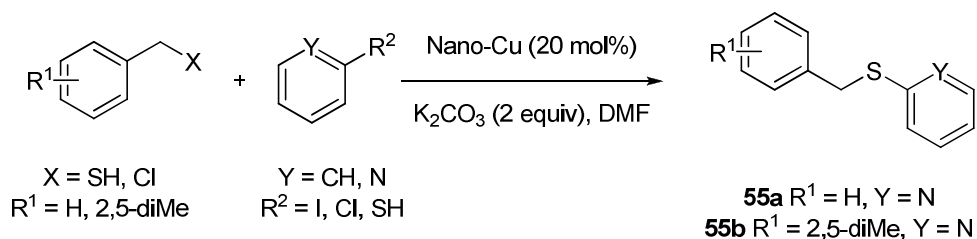

Entry	ArSH	45	Halide	39	Reaction time [h]	55 Yield [%] ^b
1		l		e	1.5	– ^c
2		l		n	1.5	55a 52
3		m		o	2	55b 81
4 ^d		m		o	2	55b 63

^a Reactions were carried out using **39e/n/o** (1.1 equiv), **45l/m** (1 equiv), copper nanopowder (20 mol%), K₂CO₃ (2 equiv) in DMF under microwave irradiation at 120 °C for the given reaction time; ^b Isolated yield after purification by column chromatography; ^c Only starting material was recovered at the end of the reaction; ^d Reaction was carried out without copper nanopowder.

The desired sulfides **55** were obtained in moderate to good yields (Table 37, entries 2 to 4), even in the absence of the catalyst in one case (entry 4). In fact, for the reaction between 2-mercaptopyridine and 2,5-dimethylbenzylchloride, the process was believed to proceed by classical nucleophilic substitution and the presence of a catalyst was not required.

The subsequent investigation was carried out using our catalytic methodology (Table 38): benzylthiol **45l** was reacted with 4-iodoanisole **39a** and 2-chloropyridine **39n**, affording the desired compounds in good yields (entries 3 and 4). A better result was obtained using ethylene glycol as ligand (entry 2) but no product was obtained using 2-mercaptopyridine as starting material (entry 1) and, overall, the influence of the copper catalyst was considered to be minimal on the outcome of the reaction.

Table 38. Formation of **55** using the CuI/diol system^a

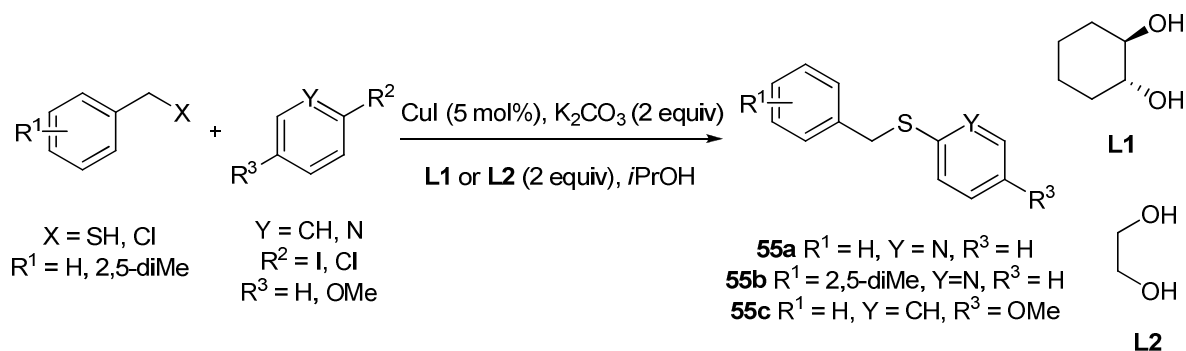

Entry	Sulfide	45	ArSH	39	L	Reaction time [h]	55 Yield [%] ^b
1		l		n	L2	2	– ^c
2 ^d		m		o	L2	2	55b 74
3		l		a	L1	3	55c 66
4		l		n	L1	3	55a 50

^a Reactions were carried out using **39a/n/o** (1 equiv), **45l/m** (1 equiv) in the presence of copper(I) iodide (5 mol%), ligand (2 equiv), K₂CO₃ (2 equiv), and *i*PrOH as solvent under microwave irradiation at 120 °C (150W) for the given reaction time; ^b Isolated yield after purification by column chromatography; ^c Only starting material was recovered at the end of the reaction; ^d Reaction was carried out with 1.1 equiv of **39o**.

With a successful route established to the desired thiopyridines, different methods were investigated for the simultaneous oxidation of sulfide to sulfone and pyridine nitrogen to pyridine *N*-oxide using a single reagent (Table 39). The oxidizing agent was *m*CPBA in the presence of a phosphate buffer at pH 7.5.¹⁵⁶ Different reaction conditions were investigated: initially the reactions were heated at 40 °C overnight (entries 1 and 2), then for 3 days at 50 °C (entry 3) and finally at 40 °C overnight, increasing the amount of oxidizing agent. From ¹H NMR spectroscopic analysis of the crude reaction mixtures, it was observed that multiple oxidation products were formed, with presence of sulfones and sulfoxides observed in the reaction mixture. In order to force the reaction to give complete oxidation, it was decided to change the oxidizing agent to urea – hydrogen peroxide (UHP).¹⁵⁷ UHP is a stable and inexpensive reagent, useful for the oxidation of a variety of substrates (sulfides and nitrogen heterocycles among them) in a mild and selective way. The sulfide **55a** was then reacted in presence of 10 equivalents of UHP and the desired compound **56a** was detected, but only in trace amounts, after MS analysis. Other oxidating agents could have been tried but, due to time constraints, this will be part of future work.

Table 39. Oxidation attempts

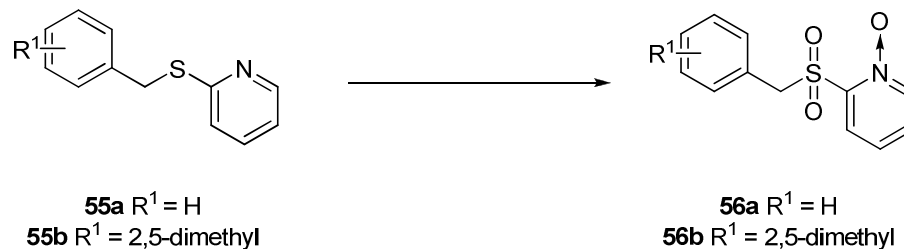

Entry	55	Reagents	Conditions	Yield [%]
1	a	<i>m</i> CPBA (4 equiv), Buffer pH 7.5, CHCl ₃	Overnight 40 °C	– ^a
2	b	<i>m</i> CPBA (4 equiv), Buffer pH 7.5, CHCl ₃	Overnight 40 °C	– ^a
3	b	<i>m</i> CPBA (4 equiv), Buffer pH 7.5, CHCl ₃	3 days 50 °C	– ^a
4	b	<i>m</i> CPBA (6 equiv), Buffer pH 7.5, CHCl ₃	Overnight 40 °C	– ^a
5	a	UHP (10 equiv)	Overnight 40 °C	56a (traces)

^a Multiple oxidation products were recovered at the end of the reaction, after ¹H NMR spectroscopic analysis of the crude reaction mixture.

3.4.3 Conclusions

Synthesis of the desired sulfides **55 a/b/c** was efficiently carried out using the Cu-catalyzed methodology developed and previously reported (see paragraph 3.2.2) alongside another method from the literature that makes use of copper nanopowder.¹⁵⁵ The oxidation step instead proved a challenging process, mostly due to difficulties in promoting the oxidation of both nitrogen and sulfur to the highest oxidation state. Despite this, some encouraging results were obtained and further investigation will be required in order to force the transformation to complete conversion.

3.5 Application to C–F bond formation

3.5.1 Introduction

Fluorinated aromatic groups are present in many compounds of pharmaceutical and agrochemical interest, representing an important class of pharmacophores.¹⁵⁸ The presence of a fluoride substituent on an aryl group is responsible for an enhancement in solubility and metabolic stability compared with non fluorinated analogues. Moreover, radioactive fluorinated compounds are commonly used as contrast agents for positron emission tomography (PET), an imaging technique used heavily in oncology, neurology and other pre-clinical studies on animals.

Chemists have been trying to find a reliable method for fluorination reactions of complex molecules over the years and, especially in recent times, new methods have been developed to incorporate fluorine on aliphatic and aromatic molecules. A classical method for the introduction of a new C–F bond in a molecule is represented by the Balz–Schiemann reaction, first published in 1927 (Scheme 102).¹⁵⁹

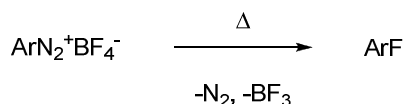

Scheme 102. Balz–Schiemann reaction

This reaction uses toxic and potentially explosive diazonium salts at high temperatures to achieve the desired fluoridation and yet it is still the preferred methodology on industrial and

laboratory scale over the alternative methods which use more toxic compounds such as thallium compounds or expensive iodonium salts (Scheme 103).^{85, 160}

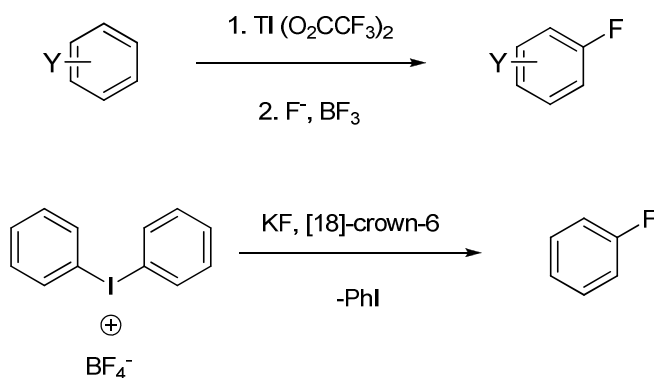

Scheme 103. Fluorination using thallium and iodonium salts

On industrial scale, it is worth mentioning the Halex reaction, in which a nucleophilic substitution of electron-deficient aryl halides (chlorides or bromides) with potassium fluoride takes place (Scheme 104).¹⁶¹ The aromatic systems can contain heteroatoms or electron-withdrawing groups such as aldehydes, nitro or cyano groups. This reaction requires high temperature and it is usually carried out in dipolar aprotic solvents.

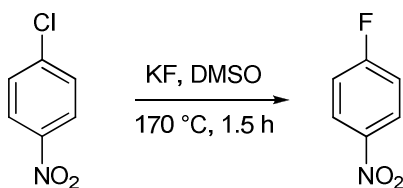

Scheme 104. Halex reaction

Considering all of the limitations of existing methods and the proven success of metal catalyzed methods for the synthesis of C–heteroatom bonds it is not surprising that wide general interest has focused on the search for a catalytic process for the fluoridation of aromatic systems (Figure 32).¹⁶²

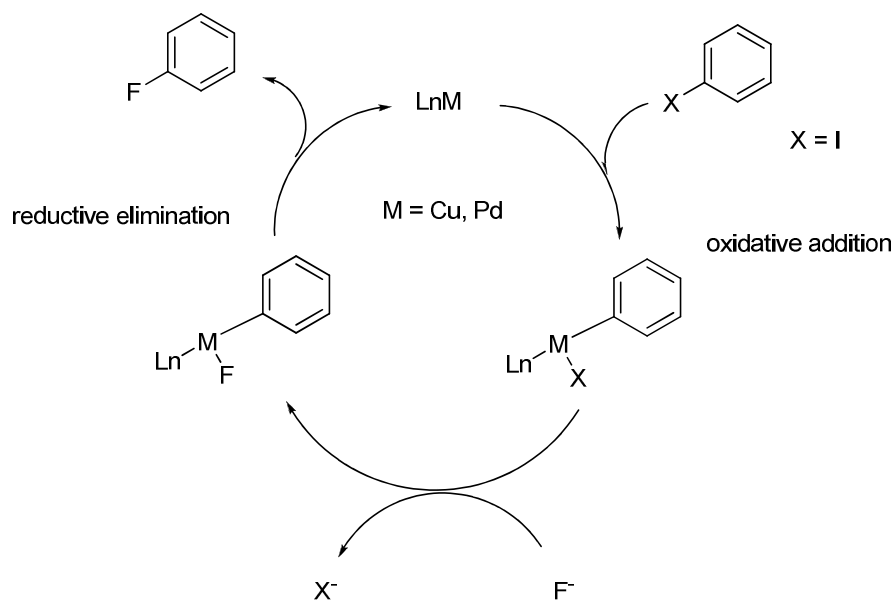
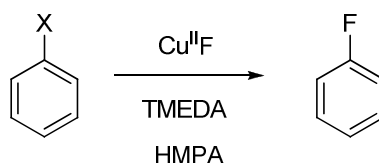

Figure 32. Proposed catalytic cycle

Recently, a new method has been published as a patent for the fluorination of an aromatic compound bearing a halide, triflate or tosylate group as substituent (Scheme 105).¹⁶³



$\text{X} = \text{Cl, Br, I,}$
 OTs or OTf

Scheme 105. Cu(II)-catalyzed fluorination

The fluoride source in this process is copper (II) fluoride in the presence of a bidentate amine ligand such as tetramethylethylenediamine. The transformation proceeds in 3-10 hours at 180 °C under conventional heating.

The first example of Pd(II)-catalyzed fluorination of arenes was first reported in 2006 by the Sanford group (see Introduction, paragraph 1.2.2).²⁴ A different approach to the electrophilic Ar-F bond forming reaction was the one devised by Ritter in 2010 (Scheme 106).¹⁶⁴ Aryl stannanes were reacted with F-TEDA-hexafluorophosphate under silver catalysis at mild temperature, giving the fluorinated compound in very good yields.

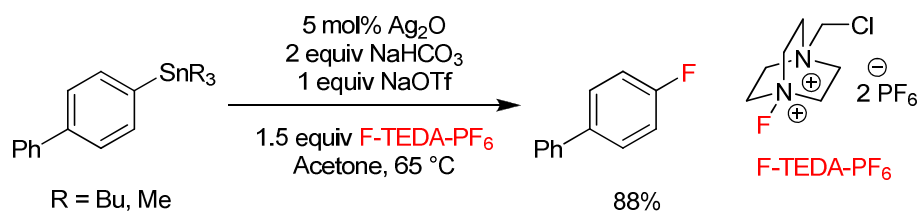

Scheme 106. Ag(I)-catalyzed aryl fluorination

The Buchwald group presented in 2009 the first example of nucleophilic Pd(0)-catalyzed fluorination of aryl triflates using caesium fluoride as fluorine source (Scheme 107).¹⁶⁵ The use of the bulky ligand *t*-BuBrettPhos was essential in the formation of a three-coordinate arylpalladium(II) fluoride complex, key in the reductive elimination step.

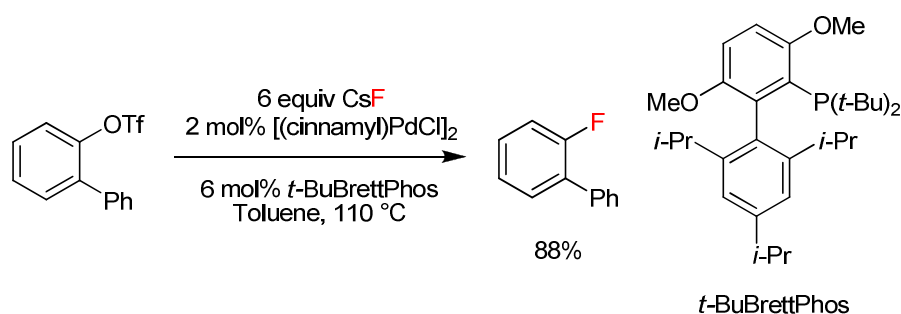

Scheme 107. First example of nucleophilic Pd(0)-catalyzed aryl fluorination

3.5.2 Results and Discussion

Given the high temperature and long times of this reaction, it was tempting for us to apply our method for Cu catalyzed C–S bond formation to this kind of transformation (Scheme 108).

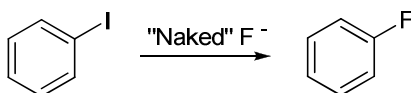

Scheme 108. General transformation proposed

The simplest iodobenzene was chosen as aryl halide, the fluoride source being tetra-*n*-butylammonium fluoride at first but then it was decided to use potassium fluoride with a crown ether in order to liberate the free fluoride ion (Table 40). The first attempt was performed in the presence of copper iodide as catalyst, (\pm)-*trans*-1,2-cyclohexanediol as ligand and potassium carbonate as base in 2-propanol with three cycles of one hour each at 120 °C. The fluoride source was then changed to potassium fluoride in presence of 18-crown-6 to

uptake the potassium cation (Table 40, entry 2). However, only the unreacted starting material was recovered at the end of both of these reactions. LR-MS analysis showed that there was formation of an undesired C–O bond, probably between the iodobenzene and the diol used as ligand. To avoid interactions of this type, it was decided to use an aprotic solvent such as acetonitrile in the next reactions. It was decided to omit the ligand as well (entries 3 and 5) and to use dry acetonitrile (entry 5 onwards). Only traces of the desired fluorobenzene were found by LR-MS analysis. When the ligand was reinstated just unreacted iodobenzene in presence of the diol was observed by ^1H NMR spectroscopic analyses (entries 4 and 6).

Table 40. In search of the elusive C–F bond formation^a

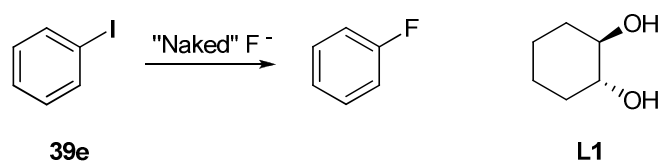

Entry	Fluoride Source	Catalyst	Ligand	Solvent	Results
1	TBAF (1.3 equiv)	CuI (5 mol%)	L1	2-propanol	–
2	KF (1 equiv), 18-crown-6 (1 equiv)	CuI (5 mol%)	L1	2-propanol	–
3	KF (1 equiv), 18-crown-6 (1 equiv)	CuI (5 mol%)	–	acetonitrile	–
4	KF (1 equiv), 18-crown-6 (1 equiv)	CuI (5 mol%)	L1	acetonitrile	–
5	KF (1 equiv), 18-crown-6 (1 equiv)	CuI (5 mol%)	–	dry acetonitrile	–
6	KF (1 equiv), 18-crown-6 (1 equiv)	CuI (5 mol%)	L1	dry acetonitrile	–
7	KF (1 equiv), 18-crown-6 (1 equiv)	PEPPSI (5 mol%)	–	dry acetonitrile	–
8	KF (1 equiv), 18-crown-6 (1 equiv)	CuI (5 mol%), PEPPSI (5 mol%)	–	dry acetonitrile	–
9 ^b	KF (1 equiv), 18-crown-6 (1 equiv)	CuI (5 mol%), PEPPSI (5 mol%)	–	dry acetonitrile	–

^a Reactions were carried out using **39e** (1 equiv), fluoride source (1 equiv) catalyst (5 mol%), ligand (2 equiv), K₂CO₃ (2 equiv.) in the chosen solvent at 120 °C using 150 W (initial power) for 3 h (hold time) under microwave irradiation; PEPPSI refers to the Pd catalyst PEPPSI-*i*Pr; ^b Reaction was performed without base.

To overcome these problems, it was decided to try to switch catalyst from a copper source to a palladium source, using the catalyst PEPPSITM-*i*Pr previously used for the optimization studies. Unfortunately, no fluoride product was obtained at the end of the three cycles (Table 40, entry 7); performing the reaction in the presence of both Cu(I) iodide and PEPPSITM-*i*Pr, mimicking a Sonogashira-coupling, did not give any improvement in the outcome of the reaction (entry 8). Finally it was decided to remove the base, which might not be needed for the catalytic cycle, but just starting material was recovered at the end of the reaction (entry 9).

3.5.3 Conclusions

The oxidation state of the catalyst has been considered to be one of the reasons for the failure of these experiments, although the simultaneous presence of the same counteranion of the fluoride source in the reaction medium might also have had a part to play. This could have deactivated the “naked” fluoride in the transmetallation step of the catalytic cycle proposed. Thus, the fluoridation of a simple aryl halide such as iodobenzene proved to be a challenging transformation that will require further investigation.

4. Summary and Conclusions

The need of the pharmaceutical industry to produce more and more intermediates in a quick, reliable and efficient way has opened new opportunities to alternative ways to batch synthesis. Microwave chemistry, continuous flow chemistry or a combination of the two could represent an alternative to classical batch reactions or could even aim to substitute classical processes, being ensured the new methods are stable, economic and as efficient as the batch ones. Traditional methods have to be tested and, if the case, adapted to be performed in continuous mode, with the straightforward possibility of scale-up by simple “addition” of microreactors (known as numbering up approach), a distinct advantage over batch reactors.

A well known process for the formation of pyridines and pyrimidines like the Bohlmann-Rahtz reaction has been chosen for this type of study. In fact, in Chapter 2 it has been shown that it is possible to efficiently transfer reaction parameters from batch to continuous flow mode and from monomode to multimode microwave for a range of different instrumentation. Particularly efficient was the 80 mL flow cell microwave reactor developed in our laboratories, in conjunction with the 10 mL flow cell and the CEM Voyager[®] stop-flow reactor. All this instrumentation proved reliable for the scale-up in the case of the Bohlmann-Rahtz cyclodehydration reaction for pyridine synthesis and for pyrimidine synthesis, with minimal if any changes of reaction parameters. On the other hand, further investigation would be required in the case of the Bohlmann-Rahtz 2-in-1 process to adapt the reaction to large scale production. For the Hantzsch dihydropyridine synthesis, transfer of parameters to flow mode has to be investigated using microwave instrumentation (10 mL and 80 mL flow cell reactors) and it has been planned as future work. The application of this methodology to the Meridianine synthesis is also part of future work, but problems related to the formation of the compound **41** have to be solved. Ideally, by protecting **42** and by trying the subsequent reaction with different organometallic reagents, **41** could be obtained and the formation of the product could be carried out under microwave irradiation (Scheme 109).

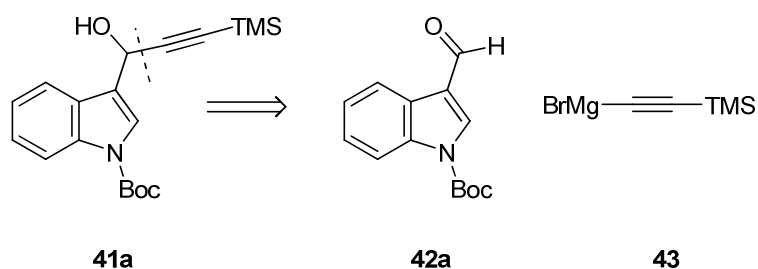

Scheme 109. Retrosynthetic approach to **41a**

A different task has been taken in Chapter 3, where a solution to the requirement for a fast and reliable method for the production of sulfides has been searched. Thus, a new methodology for efficient microwave-mediated C–S bond formation has been found and applied to the synthesis of aryl sulfides with different complexity and different electronic requirements. Initially, different metal-catalyzed methods were tested from the literature to prove their adaptability to microwave irradiation and to a different range of substrates. None of them were as efficient and reliable as the new methodology, that makes use of a combination of copper(I) iodide as catalyst and (\pm)-*trans*-1,2-cyclohexanediol as ligand, using microwave irradiation for 3 h at 120 °C. Formation of C–S bonds was selective and preferred over C–N or C–O bonds, in the case of aryl halides bearing a nitrogen or oxygen substituent.

This new methodology proved reliable in the synthesis of a drug candidate with anti-ageing properties (VX-745) and in the synthesis of a new class of anti-HIV compounds. In the synthesis of VX-745, the synthesis of **52b** was improved over one carried out under conventional heating and scale-up was carried out efficiently in the CEM Voyager[®] stop-flow reactor, with no requirements to change the reaction parameters from small to large scale. For the synthesis of a new class of anti-HIV compounds, further work is required in order to access the correct oxidation level for the nitrogen and the sulfur atoms present in the molecule. Different oxidation reagents could be tried other than the ones already investigated and this is considered to be part of future work.

Also, considering the recent developments in the C–N bond formation under flow processing,¹⁶⁶ a further effort could be made on the transferring of the C–S bond formation methodology hereby described to continuous flow synthesis, with evident opportunities for scaling-up of the process.

5. Experimental

5.1 Experimental techniques

Commercially available reagents were used without further purification; solvents were dried by standard procedures. Light petroleum refers to the fraction with b.p. 40–60 °C. Column chromatography was carried out using Merck Kieselgel 60 H silica or Matrex silica 60. Analytical thin layer chromatography was carried out using aluminium-backed plates that were visualised under UV light (at 254 and/or 360 nm) and/or potassium permanganate stain. Melting points (mp) were determined on a Kofler hot stage apparatus and are uncorrected. Infrared (IR) spectra were recorded in the range 4000–600 cm^{-1} on a Perkin–Elmer 1600 series FTIR spectrometer using nujol mull for solid samples and thin films between NaCl plates for liquid samples. Nuclear magnetic resonance (NMR) spectra were recorded in CDCl_3 at 25 °C unless stated otherwise using a Bruker DPX 400 instrument operating at 400 MHz for ^1H spectra and 100 MHz for ^{13}C spectra and were reported in ppm; J values were recorded in Hz and multiplicities were expressed by the usual conventions (s = singlet, d = doublet, t = triplet, app = apparent, m = multiplet). Low-resolution mass spectra (MS) were determined using a Fisons VG Platform II Quadrupole instrument using atmospheric pressure chemical ionization (APCI) unless otherwise stated. ES refers to electrospray ionization, CI refers to chemical ionization (ammonia) and EI refers to electron impact. High-resolution mass spectra were obtained courtesy of the EPSRC Mass Spectrometry Service at Swansea, UK using the ionisation methods specified. *In vacuo* refers to evaporation at reduced pressure using a rotary evaporator and diaphragm pump, followed by the removal of trace volatiles using a vacuum (oil) pump. Microwave experiments were carried out in a CEM Discover[®] microwave synthesizer or in a CEM Voyager[®] microwave synthesizer or in a MILESTONE BatchSynth[™]/ FlowSynth[™] microwave synthesizer at the initial power stated, which was moderated to maintain constant reaction temperature, as measured using the instrument's IR sensor (Discover) or fibre optic thermocouple (Voyager[®] or BatchSynth or Uniqsis FlowSyn[™]) for the given holding time. Continuous flow devices (10 mL flow cell, 80 mL flow cell, Milestone FlowSynth[™] and Uniqsis FlowSyn[™]) were primed before starting the reaction with the solvent of choice.

5.2 General experimental procedures

5.2.1 General procedure for the microwave-assisted cyclodehydration of aminodienones in a 10 mL glass tube reactor. The glass tube flow cell (10 mL) filled with sand (~12 g) was primed with toluene–glacial acetic acid (5:1) at a flow rate of 1.5 mL/min, irradiated at an initial power of 200 W and stabilized at 100 °C. A flask was charged with a solution of aminodienone (0.31 mmol) in toluene–glacial acetic acid (5:1; 3 mL), which was then passed through the cavity at the given flow rate, washing with further batches of solvent. The reaction mixture was quenched in a solution of saturated aqueous NaHCO₃ and extracted with AcOEt (3 × 5 mL). The organic extracts were combined, dried (Na₂SO₄) and evaporated *in vacuo* to give the crude pyridine.

5.2.2 General procedure for the microwave-assisted cyclodehydration of aminodienones in a 80 mL glass tube reactor. The glass tube flow cell (80 mL) filled with sand (~100 g) was primed with toluene–glacial acetic acid (5:1) at a flow rate of 5 mL/min, irradiated at an initial power of 200 W and stabilized at 100 °C. A flask was charged with a solution of aminodienone (1 mmol) in toluene–glacial acetic acid (5:1; 10 mL), which was then passed through the cavity at the given flow rate, washing with further batches of solvent. The reaction mixture was quenched in a solution of saturated aqueous NaHCO₃ and extracted with AcOEt (3 × 10 mL). The organic extracts were combined, dried (Na₂SO₄) and evaporated *in vacuo* to give the crude pyridine.

5.2.3 General procedure for the microwave-assisted cyclodehydration of aminodienones in a stop-flow reactor. A solution of aminodienone (2 mmol) in toluene–glacial acetic acid (5:1; 20 mL) was passed through the cavity of a monomodal microwave synthesizer (CEM Discover[®]) operating in stop-flow mode (Voyager[®]) at 100 °C (150 W initial power). The reaction mixture was quenched in a solution of saturated aqueous NaHCO₃ and extracted with AcOEt (3 × 15 mL). The organic extracts were combined, dried (MgSO₄) and evaporated *in vacuo* to give the crude pyridine.

5.2.4 General procedure for the microwave-assisted cyclodehydration of aminodienones in a multimode microwave Teflon reactor. A solution of aminodienone (1.9 mmol) in toluene–glacial acetic acid (5:1; 19 mL) was irradiated at 100 °C (150 W initial power) in a pressure-rated Teflon vessel (60 mL) using a multimodal MILESTONE BatchSynth[™]

microwave synthesizer. The reaction mixture was quenched in a solution of saturated aqueous NaHCO₃ and extracted with AcOEt (3 × 30 mL). The organic extracts were combined, dried (MgSO₄) and evaporated *in vacuo* to give the crude pyridine.

5.2.5 General procedure for the microwave-assisted cyclodehydration of aminodienones in a stainless steel reactor. A solution of aminodienone (2 mmol) in toluene–glacial acetic acid (5:1; 20 mL) was passed through the steel tubing reactor cassette (5 mL) of a UNIQUIS FlowSyn™ at 100 °C and a flow rate of 2.5 mL/min. The reaction mixture was quenched in a solution of saturated aqueous NaHCO₃ and extracted with AcOEt (3 × 10 mL). The organic extracts were combined, dried (MgSO₄) and evaporated *in vacuo* to give the crude pyridine.

5.2.6 General procedure for microwave-assisted pyrimidine synthesis: A mixture of amidine hydrochloride salt (1.2 mmol) and sodium methoxide (25 wt%, 1.3 mmol) was stirred for 5 min at room temperature and then diluted with MeOH (5 mL). Ethynyl ketone (1.0 mmol) was added and the mixture was irradiated for 2–5 min at 100 °C in a sealed tube (10 mL) using a self-tunable CEM Discover® microwave synthesizer at an initial power of 150 W. The solution was evaporated under reduced pressure and the crude residue partitioned between H₂O and AcOEt. The aqueous layer was further extracted with AcOEt. The organic extracts were combined, dried (Na₂SO₄) and evaporated *in vacuo* to give the crude pyrimidine.

5.2.7 General procedure for Ullmann-type coupling reaction using CuI/(±)-*trans*-1,2-cyclohexanediol: A solution of halide (**39**) (0.5 mmol), thiol (**45**) (0.5 mmol), CuI (0.025 mmol), (±)-*trans*-1,2-cyclohexanediol (1 mmol), K₂CO₃ (1 mmol) in 2-propanol (2 mL) was irradiated at 120 °C in a pressure-rated glass tube (10 mL) for 3 × 1 h by moderating the initial power (150 W). After cooling in a flow of compressed air, the reaction mixture was filtered and evaporated *in vacuo*. Purification by column chromatography on SiO₂, eluting with hexane–CH₂Cl₂ (3:1), gave the title compound.

5.3 Experimental procedures

(2Z,4E)-2-Amino-3-ethoxycarbonyl-6-phenylhexadien-6-one (29a).

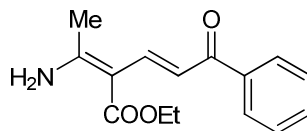

A solution of ethyl β -aminocrotonate (**28**) (1.65 g, 5.8 mmol) and 1-phenyl-2-propyn-1-one (**27a**) (2.0 g, 7.5 mmol) in EtOH (80 mL) was stirred at 50 °C for 1 h, cooled and evaporated *in vacuo*. Purification by column chromatography on SiO₂, eluting with EtOAc–light petroleum (8:2), gave the title compound as a yellow solid (2.83 g, 73%), mp 159–161 °C (light petroleum–EtOAc) (lit.¹⁶⁷ mp 164 °C) (Found: MH⁺, 260.1279. C₁₅H₁₈NO₃⁺, [MH⁺] requires 260.1281); *R*_f 0.38 (EtOAc–light petroleum, 8:2); IR (nujol)/cm⁻¹ 3339, 1625, 1584, 1537, 1499, 1379, 1350, 1322, 1287, 1223, 1207, 1178, 1111, 1058, 1036, 1022, 982, 848, 707, 628; ¹H NMR (400 MHz; CDCl₃) δ 9.71 (1H, br s), 7.95 (2H, m), 7.88 (1H, d, *J* 15.1), 7.45 (3H, m), 7.42 (1H, d, *J* 15.1), 5.73 (1H, br s), 4.22 (2H, q, *J* 7.1), 2.31 (3H, s), 1.37 (3H, t, *J* 7.1); ¹³C NMR (100 MHz; CDCl₃) δ 191.0 (C), 169.8 (C), 166.7 (C), 141.0 (CH), 139.7 (C), 131.8 (CH), 128.3 (CH), 128.1 (CH), 115.8 (CH), 95.5 (C), 60.0 (CH₂), 22.6 (CH₃), 14.5 (CH₃); MS (APCI) *m/z* (rel. intensity) 260 (MH⁺, 100%), 243 (26), 214 (18).

(2Z,4E)-2-Amino-3-ethoxycarbonyl-6-(4-chlorophenyl)hexadien-6-one (29b).

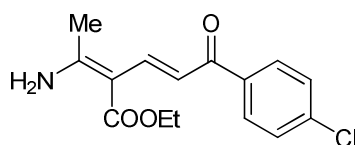

A solution of ethyl β -aminocrotonate (**28**) (0.6 g, 4.7 mmol) and 4-chlorophenyl-2-propyn-1-one (**27b**) (1.0 g, 6.1 mmol) in EtOH (80 mL) was stirred at 50 °C for 1 h, cooled and evaporated *in vacuo*. Purification by column chromatography on SiO₂, eluting with EtOAc–light petroleum (8:2), gave the title compound as a yellow solid (1.2 g, 88%), mp 164–165 °C (light petroleum–EtOAc) (Found: MH⁺, 294.0892. C₁₅H₁₇ClNO₃, [MH⁺] requires 294.0891); *R*_f 0.51 (EtOAc–light petroleum, 8:2); IR (nujol)/cm⁻¹ 3348, 1655, 1628, 1596, 1570, 1542, 1488, 1353, 1321, 1289, 1224, 1175, 1122, 1089, 1058, 1040, 1011, 976, 855, 823, 745, 717,

646, 588, 537, 501; ^1H NMR (400 MHz; CDCl_3) δ 9.68 (1H, br s), 7.86 (1H, d, J 15.0), 7.86 (2H, app d, J 8.4), 7.35 (2H, app d, J 8.4), 7.31 (1H, d, J 15.0), 5.81 (1H, br s), 4.23 (2H, q, J 7.1), 2.27 (3H, s), 1.35 (3H, t, J 7.1); ^{13}C NMR (100 MHz; CDCl_3) δ 189.6 (C), 169.7 (C), 167.0 (C), 141.6 (CH), 138.1 (C), 138.0 (C), 129.5 (CH), 128.6 (CH), 115.1 (CH), 95.6 (C), 60.1 (CH_2), 22.6 (CH_3), 14.5 (CH_3); MS (APcI) m/z (rel. intensity) 294 (MH^+ , 100), 277 (17), 260 (18).

(2Z,4E)-2-Amino-3-ethoxycarbonylheptadien-6-one (29c).

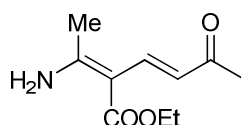

A solution of ethyl β -aminocrotonate (**28**) (1.0 g, 7.74 mmol) and 4-(trimethylsilyl)-3-butyne-2-one (**27c**) (1.63 g, 0.01 mol) in EtOH (80 mL) was stirred at 50 °C for 6 h, cooled and evaporated *in vacuo*. Purification by column chromatography on SiO_2 , eluting with EtOAc–light petroleum (8:2), gave the title compound as a pale yellow solid (1.1 g, 69%), mp 135–137 °C (light petroleum–EtOAc) (lit.¹⁶⁸ mp 135 °C) (Found: MH^+ , 198.1127. $\text{C}_{10}\text{H}_{16}\text{NO}_3$, [MH^+] requires 198.1125); R_f 0.29 (EtOAc–light petroleum, 8:2); IR (nujol)/ cm^{-1} 3332, 1648, 1554, 1489, 1443, 1352, 1310, 1277, 1200, 1183, 1111, 1023; ^1H NMR (400 MHz; CDCl_3) δ 9.62 (1H, br s), 7.52 (1H, d, J 15.4), 6.49 (1H, d, J 15.4), 5.53 (1H, br s), 4.20 (2H, q, J 7.1), 2.22 (3H, s), 2.15 (3H, s), 1.27 (3H, t, J 7.1); ^{13}C NMR (100 MHz; CDCl_3) δ 199.4 (C), 169.3 (C), 165.9 (C), 139.2 (CH), 121.1 (CH), 94.5 (C), 60.1 (CH_2), 28.2 (CH_3), 22.8 (CH_3), 14.2 (CH_3); MS (APcI) m/z (rel. intensity) 198 (MH^+ , 100%), 180 (57).

Ethyl 2-methyl-6-phenylpyridine-3-carboxylate (30a)

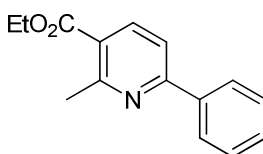

Cyclodehydration of aminodienone using toluene–acetic acid as solvent system.

Ia. (2Z,4E)-2-Amino-3-ethoxycarbonyl-6-phenylhexadien-6-one (**29a**) (80 mg, 0.31 mmol) was reacted according to general procedure 4.2.1 to give the title compound as a pale yellow solid (74 mg, 99%); mp 44–45 °C (MeOH) (lit.^{100b} mp 44 °C) (found: M^+ , 241.1104;

$C_{15}H_{15}NO_2$, [M^+] requires 241.1103); R_f 0.45 (light petroleum–ethyl acetate, 8:2); IR (KBr) ν_{max} 2995, 2905, 2346, 1715, 1581, 1476, 1270, 1091, 1022 cm^{-1} ; 1H NMR (400 MHz; $CDCl_3$) δ 8.19 (1H, d, J 8.2), 8.00 (2H, m), 7.55 (1H, d, J 8.2), 7.41 (3H, m), 4.33 (2H, q, J 7.1), 2.85 (3H, s), 1.35 (3H, t, J 7.1); ^{13}C NMR (125 MHz; $CDCl_3$) δ 165.6 (C), 158.9 (C), 158.0 (C), 138.3 (CH), 137.5 (C), 128.6 (CH), 127.8 (CH), 126.3 (CH), 122.7 (C), 116.3 (CH), 60.1 (CH_2), 24.3 (CH_3), 13.3 (CH_3); MS (EI) m/z (rel intensity) 241 (M^+ , 21%), 196 (18), 168 (8).

Ib. (2Z,4E)-2-Amino-3-ethoxycarbonyl-6-phenylhexadien-6-one (**29a**) (260 mg, 1 mmol) was reacted according to general procedure 5.2.2 to give the title compound as a pale yellow solid (385 mg, 98%), with identical physical and spectroscopic properties.

Ic. (2Z,4E)-2-Amino-3-ethoxycarbonyl-6-phenylhexadien-6-one (**29a**) (500 mg, 2 mmol) was reacted according to general procedure 5.2.3 to give the title compound as a pale yellow solid (390 mg, 81%), with identical physical and spectroscopic properties.

Id. (2Z,4E)-2-Amino-3-ethoxycarbonyl-6-phenylhexadien-6-one (**29a**) (475 mg, 1.9 mmol) was reacted according to general procedure 5.2.4 to give the title compound as a pale yellow solid (440 mg, 96%), with identical physical and spectroscopic properties.

Ie. (2Z,4E)-2-Amino-3-ethoxycarbonyl-6-phenylhexadien-6-one (**29a**) (500 mg, 2 mmol) was reacted according to general procedure 5.2.5 to give the title compound as a pale yellow solid (300 mg, 62%), with identical physical and spectroscopic properties.

II. Cyclodehydration of aminodienone in a multimode microwave 100 mL Teflon vessel.

A solution of (2Z,4E)-2-amino-3-ethoxycarbonyl-6-phenylhexadien-6-one (**29a**) (7.7 mmol, 2 g, 1 equiv.) in toluene–glacial acetic acid (5:1; 75 mL) was irradiated at 100 °C (150 W) in a pressure-rated Teflon vessel (100 mL) using a multimodal MILESTONE BatchSynthTM microwave synthesizer. The mixture was quenched immediately in a solution of saturated aqueous $NaHCO_3$ and extracted with EtOAc (3 \times 30 mL). The organic extracts were combined, dried ($MgSO_4$) and evaporated *in vacuo* to give the title compound (1.101 g, 60%) as a yellow solid, with identical physical and spectroscopic properties.

III. Cyclodehydration of aminodienone in a multimode microwave CF reactor. A solution of (2Z,4E)-2-amino-3-ethoxycarbonyl-6-phenylhexadien-6-one (**29a**) (30.5 mmol, 7.9 g, 1 equiv.) in toluene–glacial acetic acid (5:1; 650 mL) was passed through the cavity of a multimodal MILESTONE BatchSynth™ microwave synthesizer set up for the continuous flow mode (FlowSynth™) at 100 °C (150 W). The mixture was quenched immediately in a solution of saturated aqueous NaHCO₃ and extracted with EtOAc (3 × 100 mL). The organic extracts were combined, dried (MgSO₄) and evaporated *in vacuo* to give the title compound (6.95 g, 94%) as a yellow solid, with identical physical and spectroscopic properties.

IV. Two–component Bohlmann–Rahtz pyridine synthesis using microwave irradiation in a sealed tube. A solution of ethyl-β-aminocrotonate (**28**) (52 mg, 0.40 mmol) and 1-phenyl-2-propyn-1-one (**27a**) (40 mg, 0.31 mmol) in ethanol–glacial acetic acid (5:1; 3 mL) was irradiated for 5 min at 120 °C in a CEM Discover® microwave synthesizer at an initial power of 90 W. The solution was evaporated under reduced pressure and the residue was partitioned between saturated aqueous NaHCO₃ (25 mL) and AcOEt (25 mL). The aqueous layer was further extracted with AcOEt (2 × 15 mL). The organic extracts were combined, washed with brine (15 mL), dried (Na₂SO₄) and evaporated *in vacuo* to give the crude *pyridine*. Purification by column chromatography on SiO₂, eluting with light petroleum–EtOAc (8:2), gave the title compound (58 mg, 78%) as a pale yellow solid, with identical physical and spectroscopic properties.

V. Two–component Bohlmann–Rahtz pyridine synthesis in multimode microwave Teflon vessel. A solution of 1-phenyl-2-propyn-1-one (**27a**) (0.50 g, 15.4 mmol) and ethyl-β-aminocrotonate (**28**) (2.6 mL, 20.5 mmol) in ethanol–acetic acid (5:1; 37.5 mL) was irradiated at 100 °C (150 W) in a pressure-rated Teflon vessel (60 mL) using a multimodal MILESTONE BatchSynth™ microwave synthesizer for 5 min. The mixture was quenched immediately in a solution of saturated aqueous NaHCO₃ and extracted with EtOAc (3 × 30 mL). The organic extracts were combined, dried (MgSO₄) and evaporated *in vacuo*. Purification by column chromatography on SiO₂, eluting with light petroleum–EtOAc (4:1), gave the title compound (1.197 g, 32%) as a yellow solid, with identical physical and spectroscopic properties.

VI. Two–component Bohlmann–Rahtz pyridine synthesis in a multimode microwave 60 mL teflon vessel. A solution of 1-phenyl-2-propyn-1-one (**27a**) (0.50 g, 15.4 mmol) and

ethyl- β -aminocrotonate (**28**) (2.60 mL, 20.5 mmol) in [5:1] ethanol–acetic acid (37.50 mL) was irradiated at 100 °C (150 W) in a pressure-rated Teflon vessel (60 mL) using a multimodal MILESTONE BatchSynth™ microwave synthesizer for 2.5 min. The mixture was quenched immediately in a solution of saturated aqueous NaHCO₃ and extracted with EtOAc (3 × 30 mL). The organic extracts were dried (MgSO₄) and evaporated *in vacuo*. Purification by column chromatography (light petroleum/EtOAc 4:1) gave the title compound (1.048 g, 28%) as a yellow solid, mp 43–44 °C (MeOH) (lit.^{100b} mp 44 °C), with identical physical and spectroscopic properties.

VII. Two–component Bohlmann–Rahtz pyridine synthesis in a small stainless steel conductive heating flow reactor. A solution of 1-phenyl-2-propyn-1-one (**27a**) (0.16 g, 1.23 mmol) and ethyl- β -aminocrotonate (**28**) (0.20 mL, 1.60 mmol) in ethanol–acetic acid (5:1; 12 mL) was passed through the steel tubing reactor cassette (5 mL) using a UNIQUISIS FlowSyn™ at 120 °C and a flow rate of 1 mL/min. The ‘Collect’ outflow from the collection valve was directed into a collection bottle containing a stirred solution of saturated aqueous NaHCO₃ and extracted with EtOAc (3 × 10 mL). The organic extracts were combined, dried (MgSO₄) and evaporated *in vacuo* to give the title compound (0.25 g, 86%) as a yellow solid, mp 44–45 °C (lit.^{100b} mp 44 °C), with identical physical and spectroscopic properties.

VIII. Two–component Bohlmann–Rahtz pyridine synthesis in a large stainless steel conductive heating flow reactor. A solution of 1-phenyl-2-propyn-1-one (**27a**) (0.16 g, 1.23 mmol) and ethyl- β -aminocrotonate (**28**) (0.20 mL, 1.6 mmol) in ethanol–acetic acid (5:1; 12 mL) was passed through the steel tubing reactor cassette (20 mL) of a UNIQUISIS FlowSyn™ at 120 °C and a flow rate of 4 mL/min. The ‘Collect’ outflow from the collection valve was directed into a collection bottle containing a stirred solution of saturated aqueous NaHCO₃ and extracted with EtOAc (3 × 10 mL). The organic extracts were combined, dried (MgSO₄) and evaporated *in vacuo* to give the title compound (0.21 g, 71%) as a yellow solid, mp 45–46 °C (lit.^{100b} mp 44 °C), with identical physical and spectroscopic properties.

Ethyl 2-methyl-6-(4-chlorophenyl)pyridine-3-carboxylate (30b).

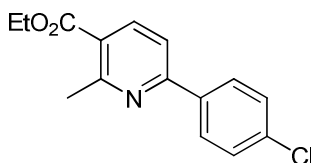

Ia. Cyclodehydration of aminodienone using toluene–acetic acid. (2*Z*,4*E*)-2-Amino-3-ethoxycarbonyl-6-(4-chlorophenyl)hexadien-6-one (**29b**) (89 mg, 0.31 mmol) was reacted according to general procedure 4.2.1 to give the title compound as a yellow solid (81 mg, 98%); mp 46–47 °C (MeOH) (lit.^{101a} mp 47–48 °C) (found: M^+ , 275.0712; $C_{15}H_{14}NO_2Cl$, [M^+] requires 275.0713); IR (KBr) ν_{max} 2979, 2925, 2349, 1723, 1585, 1469, 1271, 1089, 1013 cm^{-1} ; 1H NMR (500 MHz; $CDCl_3$) δ 8.21 (1H, d, J 8.2 Hz), 7.95 (2H, m), 7.54 (1H, d, J 8.2 Hz), 7.39 (3H, d, J 8.5), 4.33 (2H, q, J 7.1), 2.85 (3H, s), 1.35 (3H, t, J 7.1); ^{13}C NMR (125 MHz; $CDCl_3$) δ 165.5 (C), 159.0 (C), 156.6 (C), 138.4 (CH), 135.8 (C), 134.8 (C), 127.9 (CH), 127.5 (CH), 122.9 (CH), 116.0 (CH), 60.2 (CH_2), 24.2 (CH_3), 13.3 (CH_3); MS (EI) m/z (rel intensity) 275 (M^+ , 100%), 247 (34), 230 (81), 203 (22), 167 (29).

Ib. (2*Z*,4*E*)-2-Amino-3-ethoxycarbonyl-6-(4-chlorophenyl)hexadien-6-one (**29b**) (350 mg, 1.2 mmol) was reacted according to general procedure 5.2.2 to give the title compound as a yellow solid (322 mg, 97%), with identical physical and spectroscopic properties.

Ic. (2*Z*,4*E*)-2-Amino-3-ethoxycarbonyl-6-(4-chlorophenyl)hexadien-6-one (**29b**) (270 mg, 0.92 mmol) was reacted according to general procedure 5.2.3 to give the title compound as a yellow solid (240 mg, 94%), with identical physical and spectroscopic properties.

Id. (2*Z*,4*E*)-2-Amino-3-ethoxycarbonyl-6-(4-chlorophenyl)hexadien-6-one (**29b**) (500 mg, 1.7 mmol) was reacted according to general procedure 5.2.4 to give the title compound as a yellow solid (364 mg, 78%), with identical physical and spectroscopic properties.

Ie. (2*Z*,4*E*)-2-Amino-3-ethoxycarbonyl-6-(4-chlorophenyl)hexadien-6-one (**29b**) (160 mg, 0.55 mmol) was reacted according to general procedure 5.2.5 to give the title compound as a yellow solid (80 mg, 52%), with identical physical and spectroscopic properties.

Ethyl 2,6-dimethylpyridine-3-carboxylate (**30c**).

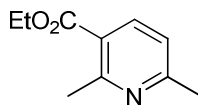

Ia. Cyclodehydration of aminodienone using toluene–acetic acid. (2*Z*,4*E*)-2-Amino-3-ethoxycarbonylheptadien-6-one (**29c**) (60 mg, 0.31 mmol) was reacted according to general procedure 4.2.1 to give the title compound as a pale yellow solid (49 mg, 91%); mp 58–60 °C (MeOH) (lit.^{100b} mp 60 °C) (found: MH^+ , 180.1018; $C_{10}H_{14}NO_2$, [MH^+] requires 180.1025) IR (KBr) ν_{max} 1720, 1591, 1272, 1235, 1148, 1080, 770, 715 cm^{-1} ; 1H NMR (400 MHz; $CDCl_3$) δ 8.03 (1H, d, J 8.0), 6.99 (1H, d, J 8.0), 4.29 (2H, q, J 7.1), 2.74 (3H, s), 2.50 (3H, s), 1.33 (3H, t, J 7.1); ^{13}C NMR (125 MHz; $CDCl_3$) δ 166.7 (C), 161.1 (C), 159.4 (C), 138.8 (CH), 122.8 (C), 120.5 (CH), 61.1 (CH_2), 24.7 (CH_3), 24.6 (CH_3), 14.3 (CH_3); MS (ApcI) m/z (rel intensity) 180 (MH^{+} , 100%), 152 (18), 115 (28).

Ib. (2*Z*,4*E*)-2-Amino-3-ethoxycarbonylheptadien-6-one (**29c**) (197 mg, 1 mmol) was reacted according to general procedure 5.2.2 to give the title compound as a pale yellow solid (153 mg, 85%), with identical physical and spectroscopic properties.

Ic. (2*Z*,4*E*)-2-Amino-3-ethoxycarbonylheptadien-6-one (**29c**) (390 mg, 2 mmol) was reacted according to general procedure 5.2.3 to give the title compound as a pale brown solid (299 mg, 83%), with identical physical and spectroscopic properties.

Id. (2*Z*,4*E*)-2-Amino-3-ethoxycarbonylheptadien-6-one (**29c**) (170 mg, 0.9 mmol) was reacted according to general procedure 5.2.4 to give the title compound as a pale brown solid (140 mg, 87%), with identical physical and spectroscopic properties.

Ie. (2*Z*,4*E*)-2-Amino-3-ethoxycarbonylheptadien-6-one (**29c**) (160 mg, 0.55 mmol) was reacted according to general procedure 5.2.5 to give the title compound as a pale brown solid (80 mg, 52%), with identical physical and spectroscopic properties.

II. Cyclodehydration of aminodienone in a multimode microwave 60 mL Teflon vessel A solution of (2*Z*,4*E*)-2-Amino-3-ethoxycarbonylheptadien-6-one (**29c**) (3.8 mmol, 0.75 g, 1 equiv.) in toluene–glacial acetic acid 5:1 (40 mL) was irradiated at 100 °C (150 W) in a pressure-rated Teflon vessel (60 mL) using a multimodal MILESTONE BatchSynth™

microwave synthesizer. The mixture was quenched immediately in a solution of saturated aqueous NaHCO_3 and extracted with EtOAc (3×20 mL). The organic extracts were combined, dried (MgSO_4) and evaporated *in vacuo* to give the title compound (0.69 g, 93%) as a pale brown solid, with identical physical and spectroscopic properties.

2,4-Diphenylpyrimidine (32a).

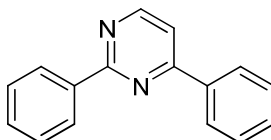

I. Synthesis in a sealed tube under microwave irradiation. Sodium methoxide (25 wt%, 0.037 g, 0.69 mmol), benzamidine hydrochloride salt (**31a**) (0.19 g, 0.62 mmol) and 1-phenyl-2-propyn-1-one (**27a**) (0.068 g, 0.52 mmol) were reacted for 2 min according to general procedure 4.2.6 to give the title compound as a yellow solid (0.104 g, 86%); mp 68-70 (lit.¹⁶⁹ mp 71 °C); (Found: M^+ , 232.0998. $\text{C}_{16}\text{H}_{12}\text{N}_2$, [M^+] requires 232.1000); IR (nujol)/ cm^{-1} 1588, 1541, 1490, 1422, 1378, 1276, 1168, 1074, 1027, 749, 687; ^1H NMR (400 MHz; CDCl_3) δ 8.72 (1H, d, J 5.3), 8.50 (2H, m), 8.12 (2H, m), 7.48 (1H, d, J 5.3), 7.42 (6H, m); ^{13}C NMR (125 MHz; CDCl_3) δ 164.6 (C), 163.9 (C), 157.9 (CH), 137.9 (C), 137.0 (C), 131.0 (CH), 130.7 (CH), 128.9 (CH), 128.6 (CH), 128.3 (CH), 127.2 (CH), 114.5 (CH); m/z (EI) 232 (M^+ , 100%).

II. Synthesis in a glass tube microwave reactor. The glass tube flow cell (10 mL) filled with sand (~12 g) was primed with methanol at a flow rate of 2.5 mL/min, irradiated at an initial power of 150 W and stabilized at 100 °C. A mixture of benzamidine hydrochloride salt (**31a**) (0.19 g, 1.25 mmol) and sodium methoxide (25 wt%, 0.073 g, 1.37 mmol) was stirred for 10 min at room temperature, then diluted with MeOH (5 mL). 1-Phenyl-2-propyn-1-one (**27a**) (0.13 g, 1.04 mmol) was passed through the cavity at the given flow rate, washing with further batches of solvent. The solution was evaporated under reduced pressure and the crude residue partitioned between H_2O and AcOEt. The aqueous layer was further extracted with AcOEt and the combined organic extracts were dried (Na_2SO_4) and evaporated *in vacuo* to give the title compound (0.203 g, 84%) as a yellow solid, with identical physical and spectroscopic properties.

III. Synthesis in a glass tube stop-flow microwave reactor. A mixture of benzamidine hydrochloride salt (**31a**) (1 g, 6.24 mmol) and sodium methoxide (25 wt%, 0.37 g, 6.86 mmol) was stirred for 5 min at room temperature, then diluted with MeOH (20 mL). 1-Phenyl-2-propyn-1-one (**27a**) (0.68 g, 5.2 mmol) was added and the mixture irradiated for 2 min at 100 °C in a monomodal microwave synthesizer (CEM Discover[®]) operating in stop-flow mode (Voyager[®]) at an initial power of 150 W. The solution was evaporated under reduced pressure and the crude residue partitioned between H₂O and AcOEt. The aqueous layer was further extracted with AcOEt and the combined organic extracts were dried (Na₂SO₄) and evaporated *in vacuo* to give the title compound (1.07 g, 89%) as a yellow solid, with identical physical and spectroscopic properties.

IV. Synthesis in a stainless steel conductive heating reactor. A mixture of benzamidine hydrochloride salt (**31a**) (0.5 g, 4.61 mmol), sodium methoxide (25 wt%, 0.185 g, 3.43 mmol) and 1-phenyl-2-propyn-1-one (**27a**) (0.34 g, 3.84 mmol) in MeOH (10 mL) was passed through the steel tubing reactor cassette (5 mL) using a UNIQUIS FlowSynTM at 100 °C and a flow rate of 1 mL/min. The solution was evaporated under reduced pressure and the crude residue partitioned between H₂O and AcOEt. The aqueous layer was further extracted with AcOEt and the combined organic extracts were dried (Na₂SO₄) and evaporated *in vacuo* to give the title compound (0.25 g, 35%) as a yellow solid, mp 70–71 °C (aq. MeOH) (lit.¹⁶⁹ mp 71 °C), with identical physical and spectroscopic properties.

2-Amino-4-phenylpyrimidine (32b).

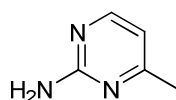

I. Synthesis in a 10 mL glass tube reactor. The glass tube flow cell (10 mL) filled with sand (~12 g) was primed with methanol at a flow rate of 1.5 mL/min, irradiated at an initial power of 200 W and stabilized at 100 °C. A mixture of guanidine hydrochloride salt (**31b**) (0.17 g, 1.82 mmol) and sodium methoxide (25 wt%, 71 mg, 1.82 mmol) was stirred for 5 min at room temperature, then diluted with MeOH (15 mL). 4-Trimethylsilyl-3-butyn-2-one (**27b**) (0.14 g, 1.0 mmol) was passed through the cavity at the given flow rate, washing with further batches of solvent. The solution was evaporated under reduced pressure and the crude residue partitioned between H₂O and AcOEt. The aqueous layer was further extracted with AcOEt

and the combined organic extracts were dried (Na_2SO_4) and evaporated *in vacuo* to give the title compound (93 mg, 85%) as a yellow solid, mp 158–160 °C (aq. MeOH) (lit.¹⁷⁰ mp 155–157 °C), (Found: M^+ , 109.0642. $\text{C}_5\text{H}_7\text{N}_3$ [M^+] requires 109.0640); IR (nujol)/ cm^{-1} 3313, 3145, 1660, 1563; ^1H NMR (400 MHz; CDCl_3) δ 8.07 (1H, d, J 5.1, 4-H), 6.42 (1H, d, J 5.1, 5-H), 5.23 (2H, br s, NH_2), 2.27 (3H, m, CH_3); ^{13}C NMR (100 MHz; d_6 -DMSO) δ 167.5 (C), 163.8 (C), 158.7 (CH), 109.8 (CH), 23.9 (CH_3); MS (EI) m/z (rel. intensity) 109 (M^{+} , 76%), 91 (34).

II. Synthesis in a 80 mL glass tube reactor. The glass tube flow cell (80 mL) filled with sand (~100 g) was primed with methanol at a flow rate of 1.5 mL/min, irradiated at an initial power of 200 W and stabilized at 100 °C. A mixture of guanidine hydrochloride salt (**31b**) (0.17 g, 1.82 mmol) and sodium methoxide (25 wt%, 71 mg, 1.82 mmol) was stirred for 5 min at room temperature, then diluted with MeOH (15 mL). 4-Trimethylsilyl-3-butyn-2-one (**27b**) (0.14 g, 1.0 mmol) was passed through the cavity at the given flow rate, washing with further batches of solvent. The solution was evaporated under reduced pressure and the crude residue partitioned between H_2O and AcOEt. The aqueous layer was further extracted with AcOEt and the combined organic extracts were dried (Na_2SO_4) and evaporated *in vacuo* to give the title compound (0.093 g, 85%) as a yellow solid, mp 156–158 °C (aq. MeOH), with identical physical and spectroscopic properties.

III. Synthesis in a glass tube stop-flow microwave reactor. A mixture of guanidine hydrochloride salt (**31b**) (0.17 g, 1.82 mmol) and sodium methoxide (25 wt%, 71 mg, 1.82 mmol) was stirred for 5 min at room temperature, then diluted with MeOH (15 mL). 4-Trimethylsilyl-3-butyn-2-one (**27b**) (0.14 g, 1.0 mmol) was added and the mixture irradiated for 5 min at 100 °C in a monomodal microwave (CEM Discover[®]) set up for the stop-flow mode (Voyager[®]) with an initial power of 200 W. The solution was evaporated under reduced pressure and the crude residue partitioned between H_2O and AcOEt. The aqueous layer was further extracted with AcOEt and the combined organic extracts were dried (Na_2SO_4) and evaporated *in vacuo* to give the title compound (0.093 g, 85%) as a yellow solid, with identical physical and spectroscopic properties.

IV. Synthesis in a Teflon vessel multimode microwave reactor. A mixture of guanidine hydrochloride salt (**31b**) (0.17 g, 1.82 mmol) and sodium methoxide (25 wt%, 71 mg, 1.82 mmol) was stirred for 5 min at room temperature, then diluted with MeOH (15 mL). 4-

Trimethylsilyl-3-butyn-2-one (**27b**) (0.59 g, 4.2 mmol) was added and the mixture irradiated for 5 min at 100 °C in a pressure-rated Teflon vessel (60 mL) using a multimodal MILESTONE BatchSynth™ microwave synthesizer. The solution was evaporated under reduced pressure and the crude residue partitioned between H₂O and AcOEt. The aqueous layer was further extracted with AcOEt and the combined organic extracts were dried (Na₂SO₄) and evaporated *in vacuo* to give the title compound (0.093 g, 85%) as a yellow solid, with identical physical and spectroscopic properties.

V. Synthesis in a Teflon vessel multimode microwave reactor. A mixture of guanidine hydrochloride salt (**31b**) (0.34 g, 3.64 mmol) and sodium methoxide (25 wt%, 0.14 g, 3.64 mmol) was stirred for 5 min at room temperature, then diluted with MeOH (30 mL). 4-Trimethylsilyl-3-butyn-2-one (**27b**) (1.18 g, 8.4 mmol) was added and the mixture irradiated for 5 min at 100 °C in a pressure-rated Teflon vessel (60 mL) using a multimodal MILESTONE BatchSynth™ microwave synthesizer. The solution was evaporated under reduced pressure and the crude residue partitioned between H₂O and AcOEt. The aqueous layer was further extracted with AcOEt and the combined organic extracts were dried (Na₂SO₄) and evaporated *in vacuo* to give the title compound (0.093 g, 85%) as a yellow solid, mp 156–157 °C (aq. MeOH) (lit.¹⁷⁰ mp 155–157 °C), with identical physical and spectroscopic properties.

VI. Synthesis in a stainless steel conductive heating reactor. A mixture of guanidine hydrochloride salt (**31b**) (0.17 g, 1.82 mmol), sodium methoxide (25 wt%, 0.071 g, 1.82 mmol) and 4-trimethylsilyl-3-butyn-2-one (**27b**) (0.2 g, 1.4 mmol) in MeOH (10 mL) was passed through the steel tubing reactor cassette (5 mL) using a UNIQUISIS FlowSyn™ at 100 °C and a flow rate of 2.5 mL/min. The solution was evaporated under reduced pressure and the crude residue partitioned between H₂O and AcOEt. The aqueous layer was further extracted with AcOEt and the combined organic extracts were dried (Na₂SO₄) and evaporated *in vacuo* to give the title compound (0.12 g, 77%) as a yellow solid, mp 155–156 °C (aq. MeOH) (lit.¹⁷⁰ mp 155–157 °C), with identical physical and spectroscopic properties.

Diethyl 4-phenyl-2,6-dimethyl-1,4-dihydropyridine-3,5-dicarboxylate (35a) (Table 12, entry 1).

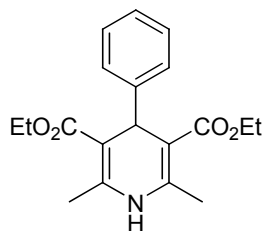

A mixture of benzaldehyde (**33a**) (0.26 g, 2.5 mmol), ethyl acetoacetate (**34a**) (1.59 mL, 12.5 mmol) and 35% aqueous ammonium hydroxide (0.55 mL, 10.0 mmol) in ethanol (1.4 mL) was irradiated for 10 min at 140 °C in a CEM Discover[®] microwave synthesizer by moderating the initial power (150 W). Purification by column chromatography on SiO₂, eluting with light petroleum–EtOAc (7:1) gave the title compound as a pale yellow solid (0.58 g, 70%); mp 158–160 °C (aq. EtOH) (lit.¹⁷¹ mp 156–157 °C); (Found: MH⁺, 330.1700. C₁₉H₂₄NO₄, [MH⁺] requires 330.1700); IR (nujol)/cm⁻¹ 3340, 1688, 1650, 1298, 1212, 1124, 1090, 1018, 827; ¹H NMR (400 MHz; CDCl₃) δ 7.23–7.03 (5H), 5.48 (1H, br s), 4.92 (1H, s), 4.02 (4H, m), 2.27 (6H, s), 1.15 (6H, t, *J* 7.1); ¹³C NMR (100 MHz; CDCl₃) δ 167.6 (C), 147.7 (C), 143.7 (C), 128.0 (CH), 127.8 (CH), 126.1 (CH), 104.3 (C), 59.7 (CH₂), 39.6 (CH), 19.6 (CH₃), 14.2 (CH₃); MS (APCI) *m/z* (rel. intensity) 330 (MH⁺, 100%), 284 (44).

Diethyl 4-phenyl-2,6-dimethyl-1,4-dihydropyridine-3,5-dicarboxylate (35a) (Table 12, entry 2). A mixture of benzaldehyde (**33a**) (0.26 g, 2.5 mmol), ethyl acetoacetate (**34a**) (1.59 mL, 12.5 mmol) and 35% aqueous ammonium hydroxide (0.55 mL, 10.0 mmol) in ethanol–water (1.4 mL) was irradiated for 10 min at 140 °C in a CEM Discover[®] microwave synthesizer by moderating the initial power (150 W). Purification by column chromatography on SiO₂, eluting with light petroleum–EtOAc (7:1) gave the title compound as a pale yellow solid (0.34 g, 41%), with identical physical and spectroscopic properties.

Diethyl 4-phenyl-2,6-dimethyl-1,4-dihydropyridine-3,5-dicarboxylate (35a) (Table 12, entry 3). A mixture of benzaldehyde (**33a**) (0.26 g, 2.5 mmol), ethyl acetoacetate (**34a**) (1.08 mL, 8.5 mmol) and 35% aqueous ammonium hydroxide (0.55 mL, 10.0 mmol) in ethanol–water (1.4 mL) was irradiated for 10 min at 140 °C in a CEM Discover[®] microwave synthesizer by moderating the initial power (150 W). Purification by column chromatography on SiO₂, eluting with light petroleum–EtOAc (7:1) gave the title compound as a pale yellow solid (0.29 g, 35%), with identical physical and spectroscopic properties.

Diethyl 4-phenyl-2,6-dimethyl-1,4-dihydropyridine-3,5-dicarboxylate (35a) (Table 12, entry 4). A mixture of benzaldehyde (**33a**) (0.52 g, 5.00 mmol), ethyl acetoacetate (**34a**) (1.04 mL, 10.04 mmol) and ammonium acetate (1.16 g, 15.10 mmol) in ethanol–AcOH [5:1] (2 mL) was irradiated for 10 min at 140 °C in a CEM Discover[®] microwave synthesizer by moderating the initial power (150 W). Purification by column chromatography on SiO₂, eluting with light petroleum–EtOAc (7:1) gave the title compound as a pale yellow solid (0.37 g, 23%), with identical physical and spectroscopic properties.

Diethyl 4-phenyl-2,6-dimethyl-1,4-dihydropyridine-3,5-dicarboxylate (35a) (Table 13, entry 1). A mixture of benzaldehyde (**33a**) (0.26 g, 2.5 mmol), ethyl acetoacetate (**34a**) (1.59 mL, 12.5 mmol) and 35% aqueous ammonium hydroxide (0.55 mL, 10.0 mmol) in ethanol (1 mL) was passed through the steel tubing reactor cassette (5 mL) using a UNIQUISIS FlowSyn™ at 140 °C and a flow rate of 0.5 mL/min. The ‘Collect’ outflow from the collection valve was poured into cold water (10 mL) and extracted with EtOAc. The organic extracts were combined, dried (MgSO₄) and evaporated *in vacuo*. Purification by column chromatography on SiO₂, eluting with light petroleum–EtOAc (7:1) gave the title compound as a pale yellow solid (0.34 g, 43%), with identical physical and spectroscopic properties.

Diethyl 4-ethyl-2,6-dimethyl-1,4-dihydropyridine-3,5-dicarboxylate (35b) (Table 12, entry 5).

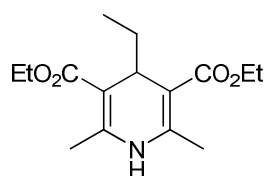

A mixture of propionaldehyde (**33b**) (0.18 mL, 2.5 mmol), ethyl acetoacetate (**34a**) (1.59 mL, 12.5 mmol) and 35% aqueous ammonium hydroxide (0.55 mL, 10.0 mmol) in ethanol (1.4 mL) was irradiated for 10 min at 140 °C in a CEM Discover[®] microwave synthesizer by moderating the initial power (150 W). The mixture was allowed to cool and evaporated *in vacuo*. Purification by column chromatography on SiO₂, eluting with light petroleum–EtOAc (8:2) gave the title compound as pale yellow solid (0.58 g, 82%); mp 111–112 °C (aq. EtOH) (lit.¹⁷² mp 110 °C); (Found: MH⁺, 282.1699. C₁₅H₂₄NO₄ [MH⁺] requires 282.1700); IR (nujol)/cm⁻¹ 3312, 1699, 1651, 1302, 1211, 1133, 1072, 999; ¹H NMR (400 MHz; CDCl₃) δ 5.38 (1H, br s), 4.17–4.04 (4H, m), 3.84 (1H, t, *J* 5.5), 2.22 (6H, s), 1.29 (2H, m), 1.23 (6H, t, *J* 7.1), 0.69 (3H, d, *J* 7.5); ¹³C NMR (100 MHz; CDCl₃) δ 168.1 (C), 144.6 (C), 102.8 (C),

59.5 (CH₂), 34.1 (CH), 29.3 (CH₂), 19.5 (CH₃), 14.4 (CH₃), 9.2 (CH₃); MS (ES) *m/z* (rel. intensity) 282 (MH⁺, 18%), 236 (100).

Diethyl 4-ethyl-2,6-dimethyl-1,4-dihydropyridine-3,5-dicarboxylate (35b) (Table 12, entry 6). A mixture of propionaldehyde (**33b**) (0.18 mL, 2.5 mmol), ethyl acetoacetate (**34a**) (1.59 mL, 12.5 mmol) and 35% aqueous ammonium hydroxide (0.55 mL, 10.0 mmol) in ethanol–water (1.4 mL) was irradiated for 10 min at 140 °C in a CEM Discover[®] microwave synthesizer by moderating the initial power (150 W). The mixture was allowed to cool and evaporated *in vacuo*. Purification by column chromatography on SiO₂, eluting with light petroleum–EtOAc (8:2) gave the title compound as pale yellow solid (0.47 g, 67%), with identical physical and spectroscopic properties.

Diethyl 4-ethyl-2,6-dimethyl-1,4-dihydropyridine-3,5-dicarboxylate (35b) (Table 12, entry 7). A mixture of propionaldehyde (**33b**) (0.18 mL, 2.5 mmol), ethyl acetoacetate (**34a**) (1.08 mL, 8.5 mmol) and 35% aqueous ammonium hydroxide (0.55 mL, 10.0 mmol) in ethanol–water (1.4 mL) was irradiated for 10 min at 140 °C in a CEM Discover[®] microwave synthesizer by moderating the initial power (150 W). The mixture was allowed to cool and evaporated *in vacuo*. Purification by column chromatography on SiO₂, eluting with light petroleum–EtOAc (8:2) gave the title compound as pale yellow solid (0.33 g, 46%), with identical physical and spectroscopic properties.

Diethyl 4-ethyl-2,6-dimethyl-1,4-dihydropyridine-3,5-dicarboxylate (35b) (Table 12, entry 8). A mixture of propionaldehyde (**33b**) (0.36 mL, 2.5 mmol), ethyl acetoacetate (**34a**) (1.04 mL, 8.5 mmol) and ammonium acetate (1.16 g, 15.10 mmol) in ethanol–AcOH (2 mL) was irradiated for 10 min at 140 °C in a CEM Discover[®] microwave synthesizer by moderating the initial power (150 W). The mixture was allowed to cool and evaporated *in vacuo*. Purification by column chromatography on SiO₂, eluting with light petroleum–EtOAc (8:2) gave the title compound as pale yellow solid (0.40 g, 28%), with identical physical and spectroscopic properties.

Diethyl 4-ethyl-2,6-dimethyl-1,4-dihydropyridine-3,5-dicarboxylate (35b) (Table 13, entry 3). A mixture of propionaldehyde (**33b**) (0.18 mL, 2.5 mmol), ethyl acetoacetate (**34a**) (1.59 mL, 12.5 mmol) and 35% aqueous ammonium hydroxide (0.55 mL, 10.0 mmol) in ethanol (1 mL) was passed through the steel tubing reactor cassette (5 mL) using a UNIQSIS

FlowSyn™ at 140 °C and a flow rate of 0.5 mL/min. The ‘Collect’ outflow from the collection valve was poured into cold water (10 mL) and extracted with EtOAc. The organic extracts were combined, dried (MgSO₄) and evaporated *in vacuo*. Purification by column chromatography on SiO₂, eluting with light petroleum–EtOAc (4:1) gave the title compound as a pale yellow solid (0.48 g, 68%), with identical physical and spectroscopic properties.

4-(Phenylthio)anisole (46a) (Table 22, entry 7).

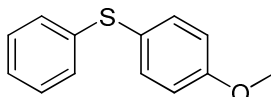

A solution of 4-iodoanisole (**39a**) (117 mg, 0.50 mmol), thiophenol (**45a**) (134.5 mg, 1.25 mmol), PEPPSI™-*i*Pr (7 mg, 0.01 mmol), LiCl (4.5 mg, 0.10 mmol) and NaOtBu (72 mg, 0.75 mmol) in dry toluene (2 mL) was irradiated at 120 °C in a pressure-rated glass tube (10 mL) for 3 × 1 h by moderating the initial power (150 W). After cooling the reaction mixture in a flow of compressed air, the reaction mixture was filtered and evaporated *in vacuo*. Purification by column chromatography on SiO₂, eluting with hexane–CH₂Cl₂ (3:1) gave the title compound (10 mg, 9%) as a yellow oil; (found: M⁺, 216.0607. C₁₃H₁₂OS requires M, 216.0609); IR (nujol)/cm⁻¹ 3058, 3002, 2938, 2835, 2537, 2044, 1594, 1573, 1505, 1491, 1474, 1439, 1286, 1180, 1094, 1081, 1023; ¹H NMR (400 MHz; CDCl₃) δ 7.35 (2H, app dt, *J* 8.8), 7.16–7.15 (2H, m), 7.11–7.05 (3H, m), 6.83 (2H, app dt, *J* 8.8), 3.75 (3H, s); ¹³C NMR (125 MHz; CDCl₃) δ 158.8 (C), 137.6 (C), 134.3 (CH), 127.9 (CH), 127.2 (CH), 124.7 (C), 123.4 (CH), 113.9 (CH), 54.4 (Me); MS (EI) *m/z* (rel. intensity) 216 (M⁺, 100), 201 (55).

4-(Phenylthio)anisole (46a) (Table 25, entry 1). A solution of 4-iodoanisole (**39a**) (234 mg, 1.0 mmol), thiophenol (**45a**) (121 mg, 1.1 mmol), CuI (19 mg, 0.1 mmol), neocuproine (20 mg, 0.1 mmol) and NaOtBu (144 mg, 1.5 mmol) in toluene (3 mL) was irradiated for 30 min at 80 °C (150 W) in a pressure-rated glass tube (10 mL) in anhydrous conditions. The reaction mixture was filtered and evaporated *in vacuo*. Purification by column chromatography on SiO₂, eluting with hexane–EtOAc (3:1) gave the title compound (89 mg, 41%) as a yellow oil, with identical physical and spectroscopic properties.

4-(Phenylthio)anisole (46a) (Table 25, entry 3). A solution of 4-iodoanisole (**39a**) (234 mg, 1.0 mmol), thiophenol (**45a**) (121 mg, 1.1 mmol), CuI (19 mg, 0.1 mmol), neocuproine (20 mg, 0.1 mmol) and NaOtBu (144 mg, 1.5 mmol) in toluene (3 mL) was irradiated for 3 × 1 h

at 120 °C (150 W) in a pressure-rated glass tube (10 mL) in anhydrous conditions. The reaction mixture was filtered and evaporated *in vacuo*. Purification by column chromatography on SiO₂, eluting with hexane–EtOAc (3:1) gave the title compound (179 mg, 83%) as a yellow oil, with identical physical and spectroscopic properties.

4-(Phenylthio)anisole (46a) (Table 25, entry 5). A solution of 4-iodoanisole (**39a**) (468 mg, 2.0 mmol), thiophenol (**45a**) (242 mg, 2.2 mmol), CuI (38 mg, 0.2 mmol), neocuproine (42 mg, 0.2 mmol) and NaOtBu (288 mg, 3.0 mmol) in toluene (6 mL) was heated at reflux for 24 h in a round bottom flask under anhydrous conditions. The reaction mixture was filtered and evaporated *in vacuo*. Purification by column chromatography on SiO₂, eluting with hexane–EtOAc (4:1) gave the title compound (262 mg, 61%) as yellow oil, with identical physical and spectroscopic properties.

4-(Phenylthio)anisole (46a) (Table 27, entry 1). A solution of 4-iodoanisole (**39a**) (117 mg, 0.5 mmol), thiophenol (**45a**) (55 mg, 0.5 mmol), CuI (5 mg, 0.025 mmol), ethylen-glycol (62 mg, 1 mmol) and K₂CO₃ (138 mg, 1 mmol) in 2-propanol (2 mL) was irradiated at 120 °C in a pressure-rated glass tube (10 mL) for 3 × 1 h by moderating the initial power (150 W). The reaction mixture was filtered and evaporated *in vacuo*. Purification by column chromatography (hexane–CH₂Cl₂ 3:1) gave the title compound (96 mg, 89%) as a yellow solid, with identical physical and spectroscopic properties.

4-(Phenylthio)anisole (46a) (Table 27, entry 2). A solution of 4-iodoanisole (**39a**) (117 mg, 0.5 mmol), thiophenol (**45a**) (55 mg, 0.5 mmol), CuCl (2.5 mg, 0.025 mmol), ethylen-glycol (62 mg, 1 mmol) and K₂CO₃ (138 mg, 1 mmol) in 2-propanol (2 mL) was irradiated at 120 °C in a pressure-rated glass tube (10 mL) for 2 × 1 h by moderating the initial power (150 W). The reaction mixture was filtered and evaporated *in vacuo*. Purification by column chromatography (hexane–CH₂Cl₂ 3:1) gave the title compound (21 mg, 19%) as a yellow solid, with identical physical and spectroscopic properties.

4-(Phenylthio)anisole (46a) (Table 27, entry 3). A solution of 4-iodoanisole (**39a**) (117 mg, 0.5 mmol), thiophenol (**45a**) (55 mg, 0.500 mmol), CuI (5 mg, 0.025 mmol), ethylen-glycol (62 mg, 1 mmol) and K₂CO₃ (138 mg, 1 mmol) in 2-propanol (2 mL) was irradiated at 130 °C in a pressure-rated glass tube (10 mL) for 3 × 1 h by moderating the initial power (150 W). The reaction mixture was filtered and evaporated *in vacuo*. Purification by column

chromatography (hexane–CH₂Cl₂ 3:1) gave the title compound (92 mg, 85%) as a yellow solid, with identical physical and spectroscopic properties.

4-(Phenylthio)anisole (46a) (Table 27, entry 4). A solution of 4-iodoanisole (**39a**) (117 mg, 0.5 mmol), thiophenol (**45a**) (55 mg, 0.5 mmol), CuI (5 mg, 0.025 mmol), ethylen-glycol (124 mg, 2 mmol) and K₂CO₃ (138 mg, 1 mmol) in 2-propanol (2 mL) was irradiated at 120 °C in a pressure-rated glass tube (10 mL) for 3 × 1 h by moderating the initial power (150 W). The reaction mixture was filtered and evaporated *in vacuo*. Purification by column chromatography (hexane–CH₂Cl₂ 3:1) gave the title compound (91 mg, 84%) as a yellow solid, with identical physical and spectroscopic properties.

4-(Phenylthio)anisole (46a) (Table 27, entry 5). A solution of 4-iodoanisole (**39a**) (117 mg, 0.5 mmol), thiophenol (**45a**) (55 mg, 0.5 mmol), CuI (5 mg, 0.025 mmol), (±)-*trans*-1,2-diaminocyclohexane (456 mg, 4 mmol) and K₂CO₃ (138 mg, 1 mmol) in 2-propanol (2 mL) was irradiated at 120 °C in a pressure-rated glass tube (10 mL) for 2 × 1 h by moderating the initial power (150 W). The reaction mixture was filtered and evaporated *in vacuo*. Purification by column chromatography (hexane–CH₂Cl₂ 3:1) gave the title compound (70 mg, 65%) as a yellow solid, with identical physical and spectroscopic properties.

4-(Phenylthio)anisole (46a) (Table 28, entry 1). A solution of 4-iodoanisole (**39a**) (117 mg, 0.5 mmol), thiophenol (**45a**) (55 mg, 0.05 mL, 0.5 mmol), CuI (5 mg, 0.025 mmol), (±)-*trans*-1,2-cyclohexanediol (116 mg, 1 mmol), K₂CO₃ (138 mg, 1 mmol) in 2-propanol (2 mL) was irradiated at 120 °C in a pressure-rated glass tube (10 mL) for 3 × 1 h by moderating the initial power (150 W). After cooling in a flow of compressed air, the reaction mixture was filtered and evaporated *in vacuo*. Purification by column chromatography on SiO₂, eluting with hexane–CH₂Cl₂ (3:1), gave the title compound (103 mg, 95%) as a yellow oil, with identical physical and spectroscopic properties.

4-(Phenylthio)anisole (46a) (Table 28, entry 2). A solution of 4-iodoanisole (**39a**) (117 mg, 0.5 mmol), thiophenol (**45a**) (55 mg, 0.05 mL, 0.5 mmol), CuI (5 mg, 0.025 mmol), (±)-*trans*-1,2-cyclohexanediol (61 mg, 0.53 mmol), K₂CO₃ (138 mg, 1 mmol) in 2-propanol (2 mL) was irradiated at 120 °C in a pressure-rated glass tube (10 mL) for 3 × 1 h by moderating the initial power (150 W). After cooling in a flow of compressed air, the reaction mixture was filtered and evaporated *in vacuo*. Purification by column chromatography on SiO₂, eluting

with hexane–CH₂Cl₂ (3:1), gave the title compound (95 mg, 88%) as a yellow oil, with identical physical and spectroscopic properties.

4-(Phenylthio)anisole (46a) (Table 28, entry 3). A solution of 4-iodoanisole (**39a**) (117 mg, 0.5 mmol), thiophenol (**45a**) (55 mg, 0.05 mL, 0.5 mmol), CuI (5 mg, 0.025 mmol), (±)-*trans*-1,2-cyclohexanediol (58 mg, 0.5 mmol), K₂CO₃ (138 mg, 1 mmol) in 2-propanol (2 mL) was irradiated at 120 °C in a pressure-rated glass tube (10 mL) for 3 × 1 h by moderating the initial power (150 W). After cooling in a flow of compressed air, the reaction mixture was filtered and evaporated *in vacuo*. Purification by column chromatography on SiO₂, eluting with hexane–CH₂Cl₂ (3:1), gave the title compound (92 mg, 85%) as a yellow oil, with identical physical and spectroscopic properties.

4-(Phenylthio)anisole (46a) (Table 28, entry 4). A solution of 4-iodoanisole (**39a**) (117 mg, 0.5 mmol), thiophenol (**45a**) (55 mg, 0.05 mL, 0.5 mmol), CuI (5 mg, 0.025 mmol), (±)-*trans*-1,2-cyclohexanediol (3 mg, 0.025 mmol), K₂CO₃ (138 mg, 1 mmol) in 2-propanol (2 mL) was irradiated at 120 °C in a pressure-rated glass tube (10 mL) for 3 × 1 h by moderating the initial power (150 W). After cooling in a flow of compressed air, the reaction mixture was filtered and evaporated *in vacuo*. Purification by column chromatography on SiO₂, eluting with hexane–CH₂Cl₂ (3:1), gave the title compound (76 mg, 70%) as a yellow oil, with identical physical and spectroscopic properties.

4-(Phenylthio)anisole (46a) (Table 28, entry 5). A solution of 4-iodoanisole (**39a**) (117 mg, 0.5 mmol), thiophenol (**45a**) (55 mg, 0.05 mL, 0.5 mmol), CuI (5 mg, 0.025 mmol), (±)-*cis*-1,2-cyclohexanediol (116 mg, 1 mmol), K₂CO₃ (138 mg, 1 mmol) in 2-propanol (2 mL) was irradiated at 120 °C in a pressure-rated glass tube (10 mL) for 3 × 1 h by moderating the initial power (150 W). After cooling in a flow of compressed air, the reaction mixture was filtered and evaporated *in vacuo*. Purification by column chromatography on SiO₂, eluting with hexane–CH₂Cl₂ (3:1), gave the title compound (73 mg, 68%) as a yellow oil, with identical physical and spectroscopic properties.

4-(Phenylthio)anisole (46a) (Table 28, entry 6). A solution of 4-iodoanisole (**39a**) (117 mg, 0.5 mmol), thiophenol (**45a**) (55 mg, 0.05 mL, 0.5 mmol), CuI (5 mg, 0.025 mmol), K₂CO₃ (138 mg, 1 mmol) in 2-propanol (2 mL) was irradiated at 120 °C in a pressure-rated glass tube (10 mL) for 3 × 1 h by moderating the initial power (150 W). After cooling in a flow of

compressed air, the reaction mixture was filtered and evaporated *in vacuo*. Purification by column chromatography on SiO₂, eluting with hexane–CH₂Cl₂ (3:1), gave the title compound (69 mg, 64%) as a yellow oil, with identical physical and spectroscopic properties.

4-(Phenylthio)anisole (46a) (Table 28, entry 8). A solution of 4-iodoanisole (**39a**) (117 mg, 0.5 mmol), thiophenol (**45a**) (55 mg, 0.05 mL, 0.5 mmol), CuI (5 mg, 0.025 mmol), (±)-*trans*-1,2-cyclohexanediol (116 mg, 1 mmol), K₂CO₃ (138 mg, 1 mmol) in 2-propanol (2 mL) was irradiated at 120 °C in the presence of silicon carbide passive heating elements in a pressure-rated glass tube (10 mL) for 3 × 1 h by moderating the initial power (150 W). After cooling in a flow of compressed air, the reaction mixture was filtered and evaporated *in vacuo*. Purification by column chromatography on SiO₂, eluting with hexane–CH₂Cl₂ (3:1), gave the title compound (92 mg, 85%) as a yellow oil with identical physical and spectroscopic properties.

4-(Phenylthio)anisole (46a) (Table 29, entry 1). A solution of 4-iodoanisole (**39a**) (117 mg, 0.5 mmol), thiophenol (**45a**) (55 mg, 0.05 mL, 0.5 mmol), CuI (5 mg, 0.025 mmol), (±)-*trans*-1,2-cyclohexanediol (116 mg, 1 mmol), K₂CO₃ (138 mg, 1 mmol) in water (2 mL) was irradiated at 120 °C in a pressure-rated glass tube (10 mL) for 3 × 1 h by moderating the initial power (150 W). After cooling in a flow of compressed air, the reaction mixture was filtered and evaporated *in vacuo*. Purification by column chromatography on SiO₂, eluting with hexane–CH₂Cl₂ (3:1), gave the title compound (34 mg, 31%) as a yellow oil, with identical physical and spectroscopic properties.

4-(Phenylthio)anisole (46a) (Table 29, entry 2). A solution of 4-iodoanisole (**39a**) (117 mg, 0.5 mmol), thiophenol (**45a**) (55 mg, 0.05 mL, 0.5 mmol), CuI (5 mg, 0.025 mmol), (±)-*trans*-1,2-cyclohexanediol (116 mg, 1 mmol), NEt₃ (101 mg, 1 mmol) in 2-propanol (2 mL) was irradiated at 120 °C in a pressure-rated glass tube (10 mL) for 3 × 1 h by moderating the initial power (150 W). After cooling in a flow of compressed air, the reaction mixture was filtered and evaporated *in vacuo*. Purification by column chromatography on SiO₂, eluting with hexane–CH₂Cl₂ (3:1), gave the title compound (65 mg, 60%) as a yellow oil, with identical physical and spectroscopic properties.

4-(Phenylthio)anisole (46a) (Table 29, entry 3). A solution of 4-iodoanisole (**39a**) (117 mg, 0.5 mmol), thiophenol (**45a**) (55 mg, 0.05 mL, 0.5 mmol), CuI (5 mg, 0.025 mmol), (±)-*trans*-

1,2-cyclohexanediol (116 mg, 1 mmol), NEt₃ (101 mg, 1 mmol) in 2-propanol (2 mL) was irradiated at 120 °C in a pressure-rated glass tube (10 mL) for 1.5 h by moderating the initial power (150 W). After cooling in a flow of compressed air, the reaction mixture was filtered and evaporated *in vacuo*. Purification by column chromatography on SiO₂, eluting with hexane-CH₂Cl₂ (3:1), gave the title compound (65 mg, 45%) as a yellow oil with identical physical and spectroscopic properties.

4-(Phenylthio)anisole (46a) (Table 29, entry 4). A solution of 4-iodoanisole (**39a**) (117 mg, 0.5 mmol), thiophenol (**45a**) (55 mg, 0.5 mmol), CuI (5 mg, 0.025 mmol), (±)-*trans*-1,2-cyclohexanediol (116 mg, 1 mmol), NEt₃ (101 mg, 1 mmol) in 2-propanol (2 mL) was irradiated at 120 °C in a pressure-rated glass tube (10 mL) for 45 min. by moderating the initial power (150 W). After cooling in a flow of compressed air, the reaction mixture was filtered and evaporated *in vacuo*. Purification by column chromatography on SiO₂, eluting with hexane-CH₂Cl₂ (3:1), gave the title compound (65 mg, 58%) as a yellow oil with identical physical and spectroscopic properties.

4-(Phenylthio)anisole (46a) (Table 29, entry 5). A solution of 4-iodoanisole (**39a**) (234 mg, 1 mmol), thiophenol (**45a**) (110 mg, 1 mmol), CuI (10 mg, 0.05 mmol), (±)-*trans*-1,2-cyclohexanediol (232 mg, 2 mmol), K₂CO₃ (276 mg, 2 mmol) in 2-propanol (5 mL) was heated at 120 °C in a three neck round bottom flask for 4 days. After cooling, the reaction mixture was filtered and evaporated *in vacuo*. Purification by column chromatography on SiO₂, eluting with hexane-CH₂Cl₂ (3:1), gave the title compound (176 mg, 81%) as a yellow oil, with identical physical and spectroscopic properties.

4-(Phenylthio)anisole (46a) (Table 29, entry 6). A solution of 4-iodoanisole (**39a**) (234 mg, 1 mmol), thiophenol (**45a**) (110 mg, 1 mmol), CuI (10 mg, 0.05 mmol), (±)-*trans*-1,2-cyclohexanediol (232 mg, 2 mmol), K₂CO₃ (276 mg, 2 mmol) in 2-propanol (5 mL) was heated at 110 °C in a three neck round bottom flask for 1 day. After cooling, the reaction mixture was filtered and evaporated *in vacuo*. Purification by column chromatography on SiO₂, eluting with hexane-CH₂Cl₂ (3:1), gave the title compound (176 mg, 84%) as a yellow oil, with identical physical and spectroscopic properties.

4-Nitrophenyl phenyl sulfide (46b) (Table 15, entry 9).

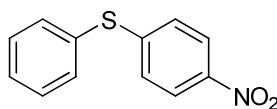

A solution of 4-nitroiodobenzene (**39b**) (249 mg, 1 mmol), thiophenol (**45a**) (132 mg, 0.12 mL, 1.2 mmol) and CsOH (336 mg, 2 mmol) in DMSO (3 mL) was stirred at room temperature for 4 hours. Saturated aqueous NH₄Cl solution was added to the reaction mixture and the organic layer was further extracted with Et₂O (3 × 20 mL). The combined organic extracts were washed with saturated aqueous NH₄Cl solution, then with brine, dried over MgSO₄, filtered and evaporated *in vacuo*. Purification by column chromatography on SiO₂, eluting with Hexane–CH₂Cl₂ (3:1) gave the title compound (61 mg, 26%) as a yellow solid, mp 50 °C (lit.¹⁷³ 50–55 °C) (found: M⁺, 231.0360. C₁₂H₉NO₂S requires M, 231.0354); IR (nujol)/cm⁻¹ 3060, 2915, 2599, 2444, 2223, 1915, 1573, 1505, 1474, 1439, 1396, 1331, 1179, 1080, 1023, 1009; ¹H NMR (400 MHz; *d*₆-DMSO) δ 8.19 (2H, dt, *J* 8.5, 2.4), 7.63–7.66 (2H, m), 7.58–7.6 (3H, m), 7.33 (2H, dt, *J* 8.5, 2.4); ¹³C NMR (400 MHz; *d*₆-DMSO) δ 148.5 (C), 145.4 (C), 134.7 (C), 130.5 (CH), 130 (CH), 129.7 (CH), 126.7 (CH), 124 (CH); MS (EI) *m/z* (rel. intensity) 231 (M⁺, 100), 201 (16), 184 (70), 152 (10).

4-Nitrophenyl phenyl sulfide (46b) (Table 15, entry 10). A solution of 4-nitroiodobenzene (**39b**) (249 mg, 1 mmol), thiophenol (**45a**) (132 mg, 1.2 mmol) and CsOH (336 mg, 2 mmol) in dry DMSO (3 mL) was irradiated at 120 °C in a pressure-rated glass tube (10 mL) for 10 min by moderating the initial power (150 W). After cooling in a flow of compressed air, the reaction mixture was filtered and evaporated *in vacuo*. Purification by column chromatography on SiO₂, eluting with hexane–CH₂Cl₂ (3:1) gave the title compound (25 mg, 11%) as a yellow solid, with identical physical and spectroscopic properties.

4-Nitrophenyl phenyl sulfide (46b) (Table 16, entry 5). A solution of 4-nitroiodobenzene (**39b**) (284 mg, 1.1 mmol), thiophenol (**45a**) (275 mg, 2.5 mmol), Pd(PPh₃)₄ (66 mg, 0.057 mmol) and NaOtBu (438 mg, 4.56 mmol) in 2-propanol (3 mL) was irradiated at 100 °C in a pressure-rated glass tube (10 mL) for 1 h by moderating the initial power (150 W). The reaction mixture was cooled to room temperature and evaporated *in vacuo*. The residue was portioned between water and hexane and the organic layer was washed successively with

water and brine, dried and evaporated *in vacuo* to give the title compound (30 mg, 12%) as a yellow solid, with identical physical and spectroscopic properties.

4-Nitrophenyl phenyl sulfide (46b) (Table 17, entry 1). A solution of 4-nitroiodobenzene (**39b**) (249 mg, 1.0 mmol), thiophenol (**45a**) (107 mg, 1.0 mmol), Pd(OAc)₂ (5.6 mg, 0.025 mmol), XantphosTM (29 mg, 0.05 mmol) and *i*Pr₂NEt (258 mg, 2 mmol) in dry dioxane (2 mL) was irradiated at 100 °C in a pressure-rated glass tube (10 mL) for 3 × 30 min by moderating the initial power (150 W). The reaction mixture was cooled to room temperature, partitioned between water and Et₂O and the aqueous layer further extracted with Et₂O. The combined organic extracts were washed with brine, dried (MgSO₄) and evaporated *in vacuo*. Purification by column chromatography on SiO₂, eluting with light petroleum–CH₂Cl₂ (3:1), gave the title compound (24 mg, 11%) as a yellow solid, with identical physical and spectroscopic properties.

4-Nitrophenyl phenyl sulfide (46b) (Table 17, entry 2). A solution of 4-nitroiodobenzene (**39b**) (249 mg, 1.00 mmol), thiophenol (**45a**) (107 mg, 1.00 mmol), Pd(OAc)₂ (5.6 mg, 0.03 mmol), XantphosTM (29 mg, 0.05 mmol) and *i*Pr₂NEt (258 mg, 2 mmol) in dry dioxane (2 mL) was irradiated at 100 °C in a pressure-rated glass tube (10 mL) for 3 × 1 h by moderating the initial power (150 W). The reaction mixture was cooled to room temperature, partitioned between water and Et₂O and the aqueous layer further extracted with Et₂O. The combined organic extracts were washed with brine, dried (MgSO₄) and evaporated *in vacuo*. Purification by column chromatography on SiO₂, eluting with light petroleum–CH₂Cl₂ (3:1), gave the title compound (144 mg, 61%) as a yellow solid, with identical physical and spectroscopic properties.

4-Nitrophenyl phenyl sulfide (46b) (Table 17, entry 3). A solution of 4-nitroiodobenzene (**39b**) (249 mg, 1.00 mmol), thiophenol (**45a**) (107 mg, 1.00 mmol), Pd(OAc)₂ (5.6 mg, 0.03 mmol), XantphosTM (29 mg, 0.05 mmol) and *i*Pr₂NEt (258 mg, 2 mmol) in dry dioxane (2 mL) was irradiated at 140 °C in a pressure-rated glass tube (10 mL) for 3 × 1 h by moderating the initial power (150 W). The reaction mixture was cooled to room temperature, partitioned between water and Et₂O and the aqueous layer further extracted with Et₂O. The combined organic extracts were washed with brine, dried (MgSO₄) and evaporated *in vacuo*. Purification by column chromatography on SiO₂, eluting with light petroleum–CH₂Cl₂ (3:1),

gave the title compound (151 mg, 65%) as a yellow solid, with identical physical and spectroscopic properties.

4-Nitrophenyl phenyl sulfide (46b) (Table 20, entry 1). A solution of 4-nitroiodobenzene (**39b**) (249 mg, 1 mmol), thiophenol (**45a**) (107 mg, 1 mmol), PEPPSITM-*i*Pr (13.5 mg, 0.02 mmol) and NaO*t*Bu (144 mg, 1.5 mmol) in dry toluene (2 mL) was irradiated at 80 °C in a pressure-rated glass tube (10 mL) for 3 × 1 h by moderating the initial power (150 W). After cooling the reaction mixture in a flow of compressed air, the reaction mixture was filtered and evaporated *in vacuo*. Purification by column chromatography on SiO₂, eluting with hexane–CH₂Cl₂ (3:1) gave the title compound (105 mg, 45%) as a yellow solid, with identical physical and spectroscopic properties.

4-Nitrophenyl phenyl sulfide (46b) (Table 20, entry 2). A solution of 4-nitroiodobenzene (**39b**) (249 mg, 1 mmol), thiophenol (**45a**) (107 mg, 1 mmol), PEPPSITM-*i*Pr (14 mg, 0.02 mmol), NaO*t*Bu (144 mg, 1.5 mmol) in dry toluene (2 mL) was irradiated at 150 °C in a pressure-rated glass tube (10 mL) for 1 h by moderating the initial power (120 W). The reaction mixture was filtrated on celite and evaporated *in vacuo*. Purification by column chromatography on SiO₂, eluting with hexane–CH₂Cl₂ (3:1) gave the title compound (20 mg, 10%) as a yellow solid, with identical physical and spectroscopic properties.

4-Nitrophenyl phenyl sulfide (46b) (Table 20, entry 3). A solution of 4-nitroiodobenzene (**39b**) (162 mg, 0.65 mmol), thiophenol (**45a**) (53 mg, 0.50 mmol), PEPPSITM-*i*Pr (7 mg, 0.01 mmol), LiCl (4.5 mg, 0.1 mmol) and NaO*t*Bu (72 mg, 0.75 mmol) in dry dioxane (2 mL) was irradiated at 120 °C in a pressure-rated glass tube (10 mL) for 3 × 1 h by moderating the initial power (150 W). The reaction mixture was partitioned between water and Et₂O and the aqueous layer further extracted with Et₂O. The combined organic extracts were washed with brine, dried on MgSO₄ and evaporated *in vacuo*. Purification by column chromatography on SiO₂, eluting with hexane–CH₂Cl₂ (3:1) gave the title compound (52 mg, 45%) as a yellow solid, with identical physical and spectroscopic properties.

4-Nitrophenyl phenyl sulfide (46b) (Table 20, entry 4). A solution of 4-nitroiodobenzene (**39b**) (162 mg, 0.65 mmol), thiophenol (**45a**) (53 mg, 0.50 mmol), PEPPSITM-*i*Pr (7 mg, 0.01 mmol), LiCl (4.5 mg, 0.10 mmol) and K₂CO₃ (138 mg, 1 mmol) in dry dioxane (2 mL) was irradiated at 120 °C in a pressure-rated glass tube (10 mL) for 3 × 1 h by moderating the

initial power (150 W). The reaction mixture was partitioned between water and Et₂O and the aqueous layer further extracted with Et₂O. The combined organic extracts were washed with brine, dried on MgSO₄ and evaporated *in vacuo*. Purification by column chromatography on SiO₂, eluting with hexane–CH₂Cl₂ (3:1) gave the title compound (51 mg, 44%) as a yellow solid, with identical physical and spectroscopic properties.

4-Nitrophenyl phenyl sulfide (46b) (Table 20, entry 5). A solution of 4-nitroiodobenzene (**39b**) (162 mg, 0.650 mmol), thiophenol (**45a**) (53 mg, 0.500 mmol), PEPPSITM-*i*Pr (17 mg, 0.025 mmol), LiCl (4.5 mg, 0.100 mmol) and K₂CO₃ (138 mg, 1 mmol) in dry dioxane (2 mL) was irradiated at 120 °C in a pressure-rated glass tube (10 mL) for 3 × 1 h by moderating the initial power (150 W). The reaction mixture was partitioned between water and Et₂O and the aqueous layer further extracted with Et₂O. The combined organic extracts were washed with brine, dried on MgSO₄ and evaporated *in vacuo*. Purification by column chromatography on SiO₂, eluting with hexane–CH₂Cl₂ (3:1) gave the title compound (64 mg, 55%) as a yellow solid, with identical physical and spectroscopic properties.

4-Nitrophenyl phenyl sulfide (46b) (Table 20, entry 6). A solution of 4-nitroiodobenzene (**39b**) (249 mg, 1 mmol), thiophenol (**45a**) (107 mg, 1.1 mmol) and NaOtBu (144 mg, 1.5 mmol) in dry toluene (2 mL) was irradiated at 120 °C in a pressure-rated glass tube (10 mL) for 3.5 h (1.5 h + 2 × 1 h) by moderating the initial power (150 W). After cooling in a flow of compressed air, the reaction mixture was filtered and evaporated *in vacuo*. Purification by column chromatography on SiO₂, eluting with hexane–CH₂Cl₂ (3:1) gave the title compound (108 mg, 47%) as a yellow solid, with identical physical and spectroscopic properties.

4-Nitrophenyl phenyl sulfide (46b) (Table 20, entry 7). A solution of 4-nitroiodobenzene (**39b**) (162 mg, 0.65 mmol), thiophenol (**45a**) (53.5 mg, 0.50 mmol), PEPPSITM-*i*Pr (7 mg, 0.01 mmol), LiCl (4.5 mg, 0.10 mmol) and NaOtBu (72 mg, 0.75 mmol) in dry toluene (2 mL) was irradiated at 120 °C in a pressure-rated glass tube (10 mL) for 3 × 1 h by moderating the initial power (150 W). After cooling in a flow of compressed air, the reaction mixture was filtered and evaporated *in vacuo*. Purification by column chromatography on SiO₂, eluting with hexane–CH₂Cl₂ (3:1) gave the title compound (86 mg, 74%) as a yellow solid, with identical physical and spectroscopic properties.

4-Nitrophenyl phenyl sulfide (46b) (Table 20, entry 8). A solution of 4-nitroiodobenzene (**39b**) (162 mg, 0.65 mmol), thiophenol (**45a**) (53 mg, 0.50 mmol), LiCl (4.5 mg, 0.10 mmol) and NaOtBu (72 mg, 0.75 mmol) in dry toluene (2 mL) was irradiated at 120 °C in a pressure-rated glass tube (10 mL) for 3 × 1 h by moderating the initial power (150 W). The reaction mixture was partitioned between water and Et₂O and the aqueous layer further extracted with Et₂O. The combined organic extracts were washed with brine, dried on MgSO₄ and evaporated *in vacuo*. Purification by column chromatography on SiO₂, eluting with hexane–CH₂Cl₂ (3:1) gave the title compound (93 mg, 80%) as a yellow solid, with identical physical and spectroscopic properties.

4-Nitrophenyl phenyl sulfide (46b) (Table 23, entry 1). A solution of 4-nitroiodobenzene (**39b**) (249 mg, 1.0 mmol), thiophenol (**45a**) (121 mg, 1.1 mmol), CuI (19 mg, 0.1 mmol), neocuproine (20 mg, 0.1 mmol) and NaOtBu (144 mg, 1.5 mmol) in dry toluene (3 mL) was irradiated at 80 °C in a pressure-rated glass tube (10 mL) for 3 × 1 h by moderating the initial power (150 W). The reaction mixture was filtered and evaporated *in vacuo*. Purification by column chromatography on SiO₂, eluting with hexane–CH₂Cl₂ (3:1) gave the title compound (142 mg, 61%) as a yellow solid, with identical physical and spectroscopic properties.

4-Nitrophenyl phenyl sulfide (46b) (Table 23, entry 2). A solution of 4-nitroiodobenzene (**39b**) (249 mg, 1.0 mmol), thiophenol (**45a**) (121 mg, 1.1 mmol), CuI (19 mg, 0.1 mmol), neocuproine (20 mg, 0.1 mmol) and NaOtBu (144 mg, 1.5 mmol) in dry toluene (2 mL) was irradiated at 100 °C in a pressure-rated glass tube (10 mL) for 3 × 1 h by moderating the initial power (150 W). The reaction mixture was filtered and evaporated *in vacuo*. Purification by column chromatography on SiO₂, eluting with hexane–CH₂Cl₂ (3:1) gave the title compound (140 mg, 60%) as a yellow solid, with identical physical and spectroscopic properties.

4-Nitrophenyl phenyl sulfide (46b) (Table 23, entry 3). A solution of 4-nitroiodobenzene (**39b**) (249 mg, 1.0 mmol), thiophenol (**45a**) (121 mg, 1.1 mmol), neocuproine (20 mg, 0.1 mmol) and NaOtBu (144 mg, 1.5 mmol) in dry toluene (2 mL) was irradiated at 100 °C in a pressure-rated glass tube (10 mL) for 3 × 1 h by moderating the initial power (150 W). The reaction mixture was filtered and evaporated *in vacuo*. Purification by column chromatography on SiO₂, eluting with hexane–CH₂Cl₂ (3:1) gave the title compound (161 mg, 70%) as a yellow solid, with identical physical and spectroscopic properties.

4-Nitrophenyl phenyl sulfide (46b) (Table 23, entry 4). A solution of 4-nitroiodobenzene (**39b**) (249 mg, 1.0 mmol), thiophenol (**45a**) (121 mg, 1.1 mmol) and NaOtBu (144 mg, 1.5 mmol) in dry toluene (2 mL) was irradiated at 100 °C in a pressure-rated glass tube (10 mL) for 3 × 1 h by moderating the initial power (150 W). The reaction mixture was filtered and evaporated *in vacuo*. Purification by column chromatography on SiO₂, eluting with hexane–CH₂Cl₂ (3:1) gave the title compound (134 mg, 58%) as a yellow solid, with identical physical and spectroscopic properties.

4-Nitrophenyl phenyl sulfide (46b) (Table 23, entry 5). A solution of 4-nitroiodobenzene (**13b**) (249 mg, 1.0 mmol), thiophenol (**19a**) (110 mg, 1.0 mmol) and NaOtBu (144 mg, 1.5 mmol) in dry toluene (2 mL) was irradiated at 120 °C in a pressure-rated glass tube (10 mL) for 2 × 1 h by moderating the initial power (150 W). After cooling in a flow of compressed air, the reaction mixture was filtered and evaporated *in vacuo*. Purification by column chromatography on SiO₂, eluting with light petroleum–CH₂Cl₂ (3:1), gave the title compound (104 mg, 45%) as a yellow solid, with identical physical and spectroscopic properties.

4-Nitrophenyl phenyl sulfide (46b) (Table 26, entry 2). A solution of 4-nitroiodobenzene (**39b**) (124 mg, 0.5 mmol), thiophenol (**45a**) (55 mg, 0.500 mmol), CuI (5 mg, 0.025 mmol), ethylen-glycol (62 mg, 1 mmol) and K₂CO₃ (138 mg, 1 mmol) in 2-propanol (3 mL) was irradiated at 120 °C in a pressure-rated glass tube (10 mL) for 3 × 1 h by moderating the initial power (150 W). The reaction mixture was filtered and evaporated *in vacuo*. Purification by column chromatography (hexane–CH₂Cl₂ 3:1) gave the title compound (95 mg, 82%) as a yellow solid, with identical physical and spectroscopic properties.

4-Nitrophenyl phenyl sulfide (46b) (Table 30, entry 6). A solution of 4-nitroiodobenzene (**39b**) (124 mg, 0.5 mmol), thiophenol (**45a**) (55 mg, 0.05 mL, 0.5 mmol), CuI (5 mg, 0.025 mmol), (±)-*trans*-1,2-cyclohexanediol (116 mg, 1 mmol), K₂CO₃ (138 mg, 1 mmol) in 2-propanol (2 mL) was irradiated at 120 °C in a pressure-rated glass tube (10 mL) for 3 × 1 h by moderating the initial power (200 W). After cooling in a flow of compressed air, the reaction mixture was filtered and evaporated *in vacuo*. Purification by column chromatography on SiO₂, eluting with hexane–CH₂Cl₂ (3:1), gave the title compound (94 mg, 81%) as a yellow solid, with identical physical and spectroscopic properties.

4-Nitrophenyl phenyl sulfide (46b) (Table 30, entry 7). A solution of 4-nitrobromobenzene (**39h**) (101 mg, 0.5 mmol), thiophenol (**45a**) (55 mg, 0.05 mL, 0.5 mmol), CuI (5 mg, 0.025 mmol), (\pm)-*trans*-1,2-cyclohexanediol (116 mg, 1 mmol), K₂CO₃ (138 mg, 1 mmol) in 2-propanol (2 mL) was irradiated at 120 °C in a pressure-rated glass tube (10 mL) for 3 × 1 h by moderating the initial power (200 W). After cooling in a flow of compressed air, the reaction mixture was filtered and evaporated *in vacuo*. Purification by column chromatography on SiO₂, eluting with hexane–CH₂Cl₂ (3:1), gave the title compound (85 mg, 74%) as a yellow solid, with identical physical and spectroscopic properties.

Diphenyl sulfide (46c) (Table 15, entry 6).

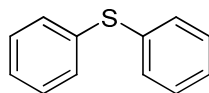

A solution of bromobenzene (**39c**) (157 mg, 1.0 mmol), thiophenol (**45a**) (132 mg, 1.2 mmol) and CsOH (336 mg, 2.0 mmol) in dry DMSO (3 mL) was irradiated at 100 °C in a pressure-rated glass tube (10 mL) for 10 min by moderating the initial power (200 W). The reaction mixture was cooled to room temperature and partitioned between saturated aqueous NH₄Cl and Et₂O. The aqueous layer was further extracted with Et₂O and the combined ethereal extracts were washed successively with saturated aqueous NH₄Cl and brine, dried (MgSO₄) and evaporated *in vacuo* to give the title compound (28 mg, 15%) as a yellow oil¹⁷⁴ (found: M⁺, 186.0510. C₁₂H₁₁S [M] requires 186.0503); ¹H NMR (400 MHz; *d*₆-DMSO) δ 7.53 (4H, d, *J* 8), 7.38 (4H, app t, *J* 8), 7.30 (2H, t, *J* 8); ¹³C NMR (100 MHz; *d*₆-DMSO) δ 136.2 (C), 130 (CH), 128.1 (CH), 127.6 (CH); MS (EI) *m/z* (rel. intensity) 186 (M⁺, 100), 171 (10).

Diphenyl sulfide (46c) (Table 18, entry 1). A solution of bromobenzene (**39c**) (78 mg, 0.5 mmol), thiophenol (**45a**) (mg, 0.5 mmol), CuI (9 mg, 0.05 mmol) and Cs₂CO₃ (326 mg, 1 mmol) in NMP (0.7 mL) was irradiated at 120 °C in a pressure-rated glass tube (10 mL) for 1 h and 30 min by moderating the initial power (200 W). The reaction mixture was cooled to room temperature, filtered on SiO₂ and evaporated *in vacuo* to give the title compound (17 mg, 12%) as a yellow oil, with identical physical and spectroscopic properties.

Diphenyl sulfide (46c) (Table 30, entry 2). A solution of iodobenzene (**39e**) (102 mg, 0.5 mmol), thiophenol (**45a**) (55 mg, 0.05 mL, 0.5 mmol), CuI (5 mg, 0.025 mmol), (\pm)-*trans*-

1,2-cyclohexanediol (116 mg, 1 mmol), K₂CO₃ (138 mg, 1 mmol) in 2-propanol (2 mL) was irradiated at 120 °C in a pressure-rated glass tube (10 mL) for 3 × 1 h by moderating the initial power (200 W). After cooling in a flow of compressed air, the reaction mixture was filtered and evaporated *in vacuo*. Purification by column chromatography on SiO₂, eluting with hexane-CH₂Cl₂ (3:1), gave the title compound (80 mg, 86%) as a yellow oil, with identical physical and spectroscopic properties.

Diphenyl sulfide (46c) (Table 30, entry 3). A solution of bromobenzene (**39c**) (78 mg, 0.5 mmol), thiophenol (**45a**) (55 mg, 0.05 mL, 0.5 mmol), CuI (5 mg, 0.025 mmol), (\pm)-*trans*-1,2-cyclohexanediol (116 mg, 1 mmol), K₂CO₃ (138 mg, 1 mmol) in 2-propanol (2 mL) was irradiated at 120 °C in a pressure-rated glass tube (10 mL) for 3 × 1 h by moderating the initial power (200 W). After cooling in a flow of compressed air, the reaction mixture was filtered and evaporated *in vacuo*. Purification by column chromatography on SiO₂, eluting with hexane-CH₂Cl₂ (3:1), gave the title compound (30 mg, 32%) as a yellow oil, with identical physical and spectroscopic properties.

2-(Phenylthio)pyridine (46d) (Table 21, entry 3).

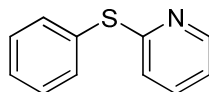

A solution of 2-iodopyridine (**39d**) (192 mg, 1.0 mmol), thiophenol (**45a**) (107 mg, 1.0 mmol), PEPPSITM-*i*Pr (13 mg, 0.02 mmol) and NaO*t*Bu (144 mg, 1.5 mmol) in dry toluene (2 mL) was irradiated at 120 °C in a pressure-rated glass tube (10 mL) for 3 × 1 h by moderating the initial power (150 W). After cooling in a flow of compressed air, the reaction mixture was filtered and evaporated *in vacuo*. Purification by column chromatography on SiO₂, eluting with light petroleum-CH₂Cl₂ (1:1), gave the title compound (119 mg, 64%) as a pale yellow oil¹⁷⁵; (found: M⁺, 187.0449. C₁₁H₉NS requires M, 187.0456); IR (nujol)/cm⁻¹ 3047, 2989, 1955, 1572, 1558, 1474, 1446, 1415, 1118, 1084, 1023, 984, 745; ¹H NMR (400 MHz; *d*₆-DMSO) δ 8.4 (1H, d, *J* 6.4), 7.65 (2H, td, *J* 10); 7.59 (2H, m), 7.5 (2H, m), 7.15 (1H, m), 6.94 (1H, d, *J* 8); ¹³C NMR (100 MHz; *d*₆-DMSO) δ 159.9 (C), 149.6 (CH), 137.4 (CH), 134.6 (C), 130.2 (CH), 129.8 (CH), 129.3 (CH), 121.1 (CH), 120.5 (CH); MS (EI⁺) *m/z* (relative intensity) 186 (100).

2-(Phenylthio)pyridine (46d) (Table 21, entry 4). A solution of 2-iodopyridine (**39d**) (192 mg, 1.0 mmol), thiophenol (**45a**) (107 mg, 0.10 mL, 1.0 mmol), PEPPSITM-*i*Pr (13 mg, 0.02 mmol), LiCl (9 mg, 0.2 mmol) and NaOtBu (144 mg, 1.5 mmol) in dry toluene (2 mL) was irradiated at 120 °C in a pressure-rated glass tube (10 mL) for 3 × 1 h by moderating the initial power (150 W). After cooling in a flow of compressed air, the reaction mixture was filtered and evaporated *in vacuo*. Purification by column chromatography on SiO₂, eluting with light petroleum–CH₂Cl₂ (1:1), gave the title compound (165 mg, 88%) as a pale yellow oil, with identical physical and spectroscopic properties.

2-(Phenylthio)pyridine (46d) (Table 24, entry 1). A solution of 2-iodopyridine (**39d**) (192 mg, 1.0 mmol), thiophenol (**45a**) (107 mg, 1.0 mmol), CuI (19 mg, 0.1 mmol), neocuproine (20 mg, 0.1 mmol) and NaOtBu (144 mg, 1.5 mmol) in dry toluene (2 mL) was irradiated at 80 °C in a pressure-rated glass tube (10 mL) for 2 × 1 h by moderating the initial power (150 W). The reaction mixture was filtered and evaporated *in vacuo*. Purification by column chromatography on SiO₂, eluting with hexane–CH₂Cl₂ (1:1) gave the title compound (134 mg, 72%) as a pale yellow oil, with identical physical and spectroscopic properties.

2-(Phenylthio)pyridine (46d) (Table 24, entry 2). A solution of 2-iodopyridine (**39d**) (192 mg, 1.0 mmol), thiophenol (**45a**) (107 mg, 0.10 mL, 1.0 mmol), CuI (19 mg, 0.10 mmol), neocuproine (20 mg, 0.10 mmol) and NaOtBu (144 mg, 1.5 mmol) in dry toluene (2 mL) was irradiated at 120 °C for 3 × 1 h in a pressure-rated glass tube (10 mL) using a CEM Discover[®] microwave synthesiser by moderating the initial power (150 W). After cooling in a flow of compressed air, the reaction mixture was filtered and evaporated *in vacuo*. Purification by column chromatography on SiO₂, eluting with light petroleum–CH₂Cl₂ (1:1), gave the title compound (180 mg, 96%) as a pale yellow oil, with identical physical and spectroscopic properties.

2-(Phenylthio)pyridine (46d) (Table 24, entry 3). A solution of 2-iodopyridine (**39d**) (192 mg, 1.0 mmol), thiophenol (**45a**) (118 mg, 1.1 mmol), neocuproine (21 mg, 0.1 mmol) and NaOtBu (144 mg, 1.5 mmol) in dry toluene (2 mL) was irradiated at 120 °C in a pressure-rated glass tube (10 mL) for 3 × 1 h by moderating the initial power (150 W). After cooling in a flow of compressed air, the reaction mixture was filtered and evaporated *in vacuo*. Purification by column chromatography on SiO₂, eluting with light petroleum–CH₂Cl₂ (1:1),

gave the title compound (142 mg, 76%) as a pale yellow oil, with identical physical and spectroscopic properties.

2-(Phenylthio)pyridine (46d) (Table 30, entry 1). A solution of 2-iodopyridine (**39d**) (96 mg, 0.5 mmol), thiophenol (**45a**) (55 mg, 0.05 mL, 0.5 mmol), CuI (5 mg, 0.025 mmol), (\pm)-*trans*-1,2-cyclohexanediol (116 mg, 1 mmol), K₂CO₃ (138 mg, 1 mmol) in 2-propanol (2 mL) was irradiated at 120 °C in a pressure-rated glass tube (10 mL) for 3 × 1 h by moderating the initial power (150 W). After cooling in a flow of compressed air, the reaction mixture was filtered and evaporated *in vacuo*. Purification by column chromatography on SiO₂, eluting with hexane–CH₂Cl₂ (3:1), gave the title compound (91 mg, 91%) as a pale yellow oil, with identical physical and spectroscopic properties.

4-(Methylphenyl)phenyl sulfide (46e) (Table 30, entry 5).

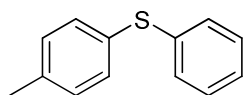

A solution of 4-iodotoluene (**39g**) (109 mg, 0.5 mmol) and thiophenol (**45a**) (55 mg, 0.05 mL, 0.5 mmol) was reacted according to general procedure 5.2.7 to give the title compound¹⁷⁶ (76 mg, 76%); (found: M⁺, 200.0657. C₁₃H₁₂S [*M*] requires 200.0660); ¹H NMR (400 MHz; *d*₆-DMSO) δ 7.18 (2H, d, *J* 8.1), 7.16–7.13 (4H, m), 7.09–7.05 (1H, m), 7.02–6.99 (2H, d, *J* 7.3), 2.30 (3H, s); ¹³C NMR (100 MHz; *d*₆-DMSO) δ 139.2 (CH), 137 (C), 132.6 (C), 131.1 (CH), 130.6 (CH), 129.7 (CH), 128.5 (CH), 127.2 (CH), 22.5 (CH); MS (EI) *m/z* (rel. intensity) 200 (M⁺, 100), 185 (50).

1-(Cyclohexylthio)-4-methoxybenzene (46f) (Table 30, entry 8).

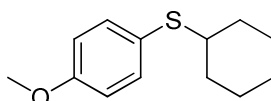

A solution of 4-iodoanisole (**39a**) (117 mg, 0.5 mmol) and cyclohexylmercaptan (**45c**) (58 mg, 0.06 mL, 0.5 mmol) was reacted according to general procedure 5.2.7 to give the title compound (53 mg, 48%) as a light brown oil; (found: M⁺, 222.1078. C₁₃H₁₈OS [*M*] requires 222.1078); IR (nujol)/cm⁻¹ 2926, 2851, 1591, 1570, 1492, 1462, 1447, 1283, 1241, 1171,

1101, 1031, 997; ^1H NMR (250 MHz; d_6 - CHCl_3) δ 7.42 (2H, app dt, J 8.8, 3.0, 2.1), 6.87 (1H, app dt, J 8.8, 3.0, 2.1), 3.83 (3H, s), 2.97–2.87 (1H, m), 1.99–1.94 (1H, m), 1.81–1.76 (1H, m), 1.65–1.59 (1H, m), 1.42–1.23 (1H, m); ^{13}C NMR (100 MHz; d_6 -DMSO) δ 159.7 (C), 129.8 (C), 128.2 (CH), 116.5 (CH), 57.2 (CH), 54.2 (CH), 37.3 (CH), 29.5 (CH), 26.0 (CH); MS (EI) m/z (rel. intensity) 222 (M^+ , 46%), 140 (100).

2-(Phenylthio)anisole (46g) (Table 31, entry 1).

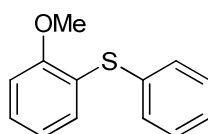

A solution of 2-iodoanisole (**39i**) (117 mg, 0.5 mmol) and thiophenol (**45a**) (55 mg, 0.05 mL, 0.5 mmol) was reacted according to general procedure 5.2.7 to give the title compound (103 mg, 95%) as a pale yellow oil¹³⁸; (found: M^+ , 216.0612. $\text{C}_{13}\text{H}_{12}\text{OS}$ [M] requires 216.0609); ^1H NMR (400 MHz; d_6 -DMSO) δ 7.53 (4H, d, J 8), 7.38 (4H, app t, J 8), 7.30 (2H, t, J 8); ^{13}C NMR (100 MHz; d_6 -DMSO) δ 136.2 (C), 130 (CH), 128.1 (CH), 127.6 (CH); MS (EI) m/z (rel. intensity) 216 (M^+ , 100), 168 (15).

4-(2,4-Difluorophenylthio)anisole (46i) (Table 31, entry 3).

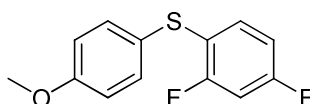

A solution of 4-iodoanisole (**39a**) (117 mg, 0.5 mmol) and 2,4-difluorothiophenol (**45b**) (72 mg, 0.11 mL, 1 mmol) was reacted according to general procedure 5.2.7 to give the title compound (99 mg, 78%) as a clear oil; (found: M^+ , 252.0424. $\text{C}_{13}\text{H}_{10}\text{OSF}_2$ [M] requires 252.0420); ^1H NMR (400 MHz; d_6 -DMSO) δ 7.65 (1H, dd, J 5.52, 1.81), 7.45–7.33 (4H, m), 7.08 (1H, ddd, J 8.56, 5.52, 2.16), 6.99 (1H, ddd, J 8.56, 5.52, 2.16), 3.77 (3H, s); ^{13}C NMR (100 MHz; d_6 -DMSO) δ 168.4 (C), 165.1 (C), 160.8 (C), 136.9 (CH), 132.0 (CH), 131.6 (CH), 119.4 (CH), 115.7 (CH), 114.5 (CH), 112.2 (CH), 107.6 (CH), 57.2 (CH); MS (EI) m/z (rel. intensity) 252 (M^+ , 64%), 237 (40), 83 (100).

1,2-Bis(phenylthio)benzene (46j) (Table 31, entry 4).

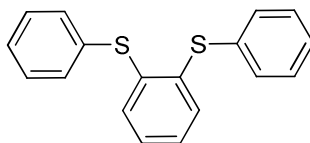

A solution of 2-bromoiodobenzene (**39k**) (132 mg, 0.06 mL, 0.5 mmol) and thiophenol (**45a**) (118 mg, 0.11 mL, 1 mmol) was reacted according to general procedure 5.2.7 to give the title compound (138 mg, 94%) as a clear oil; (found: M^+ , 294.0539. $C_{18}H_{14}S_2$ [M] requires 294.0537); IR (nujol)/ cm^{-1} 3056, 1949, 1808, 1575, 1558, 1475, 1446, 1426, 1327, 1305, 1250, 1104, 1018, 999; 1H NMR (400 MHz; d_6 -DMSO) δ 7.69 (2H, dd, J 7.9, 1.6), 7.54–7.38 (2H, m), 7.31 (2H, app dt, J 7.6, 1.6), 7.18 (2H, app dt, J 7.6, 1.6), 6.93 (2H, dd, J 7.9, 1.6); ^{13}C NMR (100 MHz; d_6 -DMSO) δ 137.4 (C), 133.1 (CH), 132.8 (CH), 131.9 (CH), 130.0, 129.9, 129.4, 128.7, 128.5, 128.2, 127.6, 127.2, 122.5; MS (EI) m/z (rel. intensity) 294 (M^+ , 100%), 184 (55).

1,2-Bis(phenylthio)benzene (46j) (Table 31, entry 5). A solution of 1,2-diiodobenzene (**39l**) (164 mg, 0.065 mL, 0.5 mmol) and thiophenol (**45a**) (107 mg, 0.1 mL, 1 mmol) was reacted according to general procedure 5.2.7 to give the title compound (120 mg, 81%) as a yellow oil, with identical physical and spectroscopic properties.

1,4-Dimethyl-2-[(4-nitrophenyl)thio]benzene (46k) (Table 31, entry 6).

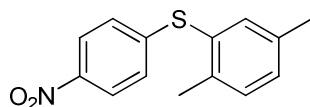

A solution of 4-nitroiodobenzene (**39b**) (124 mg, 0.5 mmol) and 2,5-dimethylbenzenethiol (**45d**) (55 mg, 0.07 mL, 0.5 mmol) was reacted according to general procedure 5.2.7 to give the title compound (97 mg, 75%) as a pale yellow oil; (found: M^+ , 259.0666. $C_{14}H_{13}NO_2S$ [M] requires 259.0667); IR (nujol)/ cm^{-1} 2919, 1917, 1592, 1579, 1509, 1489, 1476, 1331, 1085, 1057, 851, 839; 1H NMR (250 MHz; d_6 -DMSO) δ 7.43–7.28 (5H, m), 7.22 (1H, s), 6.94 (1H, app dd, J 7.7, 0.9), 6.89 (1H, t, J 2.3, 1.7), 6.81 (1H, app dd, J 8.2, 0.8), 3.79 (3H, s); ^{13}C NMR (100 MHz; d_6 -DMSO) δ 149.7 (C), 135.8 (CH), 134.2 (CH), 129.9 (CH), 129.8, 129.3, 118.4, 116.1, 113.3; MS (EI) m/z (rel. intensity) 259 (M^+ , 50%), 229 (96), 85 (100).

2-[(4-Methoxyphenyl)thio]-1,4-dimethyl-benzene (46l) (Table 31, entry 7).

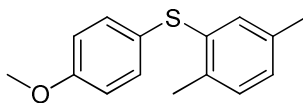

A solution of 4-iodoanisole (**13a**) (117 mg, 0.5 mmol) and 2,5-dimethylbenzenethiol (**19d**) (55 mg, 0.07 mL, 0.5 mmol) was reacted according to general procedure 5.2.7 to give the title compound (97 mg, 79%) as a clear oil; (found: M^+ , 244.0925. $C_{15}H_{16}OS$ [M] requires 244.0922); IR (nujol)/ cm^{-1} 2920, 2835, 1592, 1571, 1483, 1461, 1439, 1286, 1205, 1171, 1103, 1059, 1030, 824, 805; 1H NMR (250 MHz; d_6 -DMSO) δ 7.43–7.28 (5H, m), 7.22 (1H, s), 6.94 (1H, app dd, J 7.7, 0.9), 6.89 (1H, t, J 2.3, 1.7), 6.81 (1H, app dd, J 8.2, 0.8), 3.79 (3H, s); ^{13}C NMR (100 MHz; d_6 -DMSO) δ 149.7 (C), 135.8 (CH), 134.2 (CH), 129.9 (CH), 129.8, 129.3, 118.4, 116.1, 113.3; MS (EI) m/z (rel. intensity) 244 (M^{+} , 48%), 229 (12), 83 (100).

2-Methyl-4-nitro-1-(phenylthio)benzene (46m) (Table 31, entry 8).

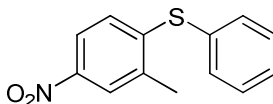

A solution of 2-iodo-5-nitrotoluene (**39m**) (132 mg, 0.5 mmol) and thiophenol (**45a**) (55 mg, 0.05 mL, 0.5 mmol) was reacted according to general procedure 5.2.7 to give the title compound (81 mg, 66%) as a clear oil; (found: M^+ , 245.0503. $C_{13}H_{11}NO_2S$ [M] requires 245.0511); 1H NMR (400 MHz; d_6 -DMSO) δ 8.16 (1H, d, J 2.5), 7.96 (1H, dd, J 8.7, 2.6), 6.88 (1H, d, J 8.76), 7.57–7.53 (5H, m), 2.44 (3H, s); ^{13}C NMR (100 MHz; d_6 -DMSO) δ 148.7 (C), 145.1 (C), 141.2 (C), 135.8 (C), 132.8 (CH), 132.6 (CH), 131.5 (CH), 129.7 (CH), 129.4 (CH), 127.7 (CH), 121.4 (CH), 119.1 (CH), 18.3 (CH); MS (EI) m/z (rel. intensity) 245 (M^{+} , 23%), 215 (100), 199 (14).

4,4'-Thiodianisole (46r) (Table 32, entry 5).

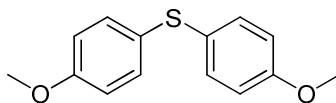

A solution of 4-iodoanisole (**39a**) (117 mg, 0.5 mmol) and 4-methoxythiophenol (**45g**) (70 mg, 0.06 ml, 0.5 mmol) was reacted according to general procedure 5.2.7 to give the title compound (122 mg, 99%) as a colourless solid, mp 38 °C (lit.¹⁷⁷ 50–55 °C) (found: M^+ , 246.0717. $C_{14}H_{14}O_2S$ requires M , 246.0715); IR (KBr) ν_{max} 3450, 2938, 2838, 1590 cm^{-1} ; 1H NMR (400 MHz; $CDCl_3$) δ 7.20, 6.76 (8H, AA'XX', J_{AX} 8.6), 3.72 (6H, s); ^{13}C NMR (62.5 MHz; $CDCl_3$) δ 159.0 (C), 132.8 (CH), 127.5 (C), 114.8 (CH), 55.4 (Me); MS (EI^+) m/z (rel. intensity) 246 (M^+ , 100), 231 (95), 203 (24), 188 (20).

4-Nitrophenyl-2,4-difluorophenyl sulfide (46y) (Table 21, entry 5).

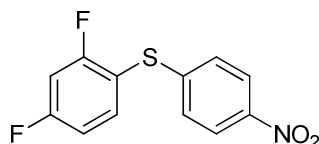

A solution of 4-nitroiodobenzene (**39b**) (187 mg, 0.75 mmol), 2,4-difluorothiophenol (**45b**) (73 mg, 0.50 mmol), PEPPSITM-*i*Pr (17 mg, 0.03 mmol) and NaOtBu (72 mg, 0.75 mmol) in dry toluene (2 mL) was irradiated at 130 °C in a pressure-rated glass tube (10 mL) for 2 × 1 h by moderating the initial power (150 W). After cooling in a flow of compressed air, the reaction mixture was filtered and evaporated *in vacuo*. Purification by column chromatography on SiO_2 , eluting with light petroleum– CH_2Cl_2 (1:1), gave the title compound (55 mg, 41%) as a pale yellow oil; IR (nujol)/ cm^{-1} 3060, 2916, 2599, 2445, 2222, 1915, 1573, 1506, 1474, 1439, 1397, 1331, 1179, 1094, 1080, 1023, 1009, 911, 851, 837; 1H NMR (400 MHz; $CDCl_3$) δ 8.15 (1H, app dt, J 8.56, 1.86, 0.52), 8.07 (1H, app dt, J 8.52, 1.86, 0.49), 7.99 (1H, app dt, J 8.56, 1.58, 0.49), 7.81 (1H, app dt, J 8.52, 1.58, 0.52), 7.59 (1H, dd, J 5.45, 2.02), 7.34–7.28 (2H, m).

4-Nitrophenyl-2,4-difluorophenyl sulfide (46y) (Table 21, entry 6). A solution of 4-nitroiodobenzene (**39b**) (124 mg, 0.50 mmol), 2,4-difluorothiophenol (**45b**) (73 mg, 0.50 mmol), PEPPSITM-*i*Pr (7 mg, 0.01 mmol) and NaOtBu (72 mg, 0.75 mmol) in dry toluene (2 mL) was irradiated at 120 °C in a pressure-rated glass tube (10 mL) for 3 × 1 h by moderating

the initial power (150 W). After cooling in a flow of compressed air, the reaction mixture was filtered and evaporated *in vacuo*. Purification by column chromatography on SiO₂, eluting with hexane–CH₂Cl₂ (3:1), gave the title compound (38 mg, 28%) as a pale yellow oil, with identical physical and spectroscopic properties.

4-Nitrophenyl-2,4-difluorophenyl sulfide (46y) (Table 23, entry 6). A solution of 4-nitroiodobenzene (**39b**) (249 mg, 1.0 mmol), 2,4-difluorothiophenol (**45b**) (161 mg, 1.1 mmol), CuI (19 mg, 0.1 mmol), neocuproine (20 mg, 0.1 mmol) and NaOtBu (144 mg, 1.5 mmol) in dry toluene (3 mL) was irradiated at 120 °C in a pressure-rated glass tube (10 mL) for 3 × 1 h by moderating the initial power (150 W). After cooling in a flow of compressed air, the reaction mixture was filtered and evaporated *in vacuo*. Purification by column chromatography on SiO₂, eluting with hexane–CH₂Cl₂ (3:1), gave the title compound (225 mg, 84%) as a pale yellow oil, with identical physical and spectroscopic properties.

Diphenyl disulfide (47) (Table 15, entries 1 and 2).

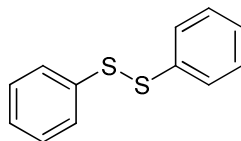

A solution of bromobenzene (**39c**) (157 mg, 1.0 mmol), thiophenol (**45a**) (132 mg, 1.2 mmol) and CsOH (336 mg, 2.0 mmol) in DMSO (3 mL) was irradiated at 120 °C in a pressure-rated glass tube (10 mL) for 5–10 min by moderating the initial power (200–250 W). The reaction mixture was cooled to room temperature and partitioned between saturated aqueous NH₄Cl and Et₂O. The aqueous layer was further extracted with Et₂O and the combined ethereal extracts were washed successively with saturated aqueous NH₄Cl and brine, dried (MgSO₄) and evaporated *in vacuo* to give the title compound (140 mg, 75%; 0.102 g, 55%) as a yellow solid, mp 61 °C (lit.¹⁷⁸ mp 61–63 °C); ¹H NMR (400 MHz; *d*₆–DMSO) δ 7.53 (4H, d, *J* 8), 7.38 (4H, app t, *J* 8), 7.30 (2H, t, *J* 8); ¹³C NMR (100 MHz; *d*₆–DMSO) δ 136.2 (C), 129.9 (CH), 128 (CH), 127.6 (CH); MS (EI) *m/z* (rel. intensity) 218 (M⁺, 95%), 185 (15), 154 (20), 109 (100).

α -(2,6-Dichlorophenyl)-6-[(2,4-difluorophenyl)thio]-3-pyridazineacetonitrile (52b)

(Table 35, entry 1).

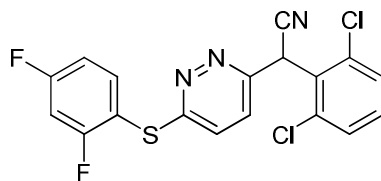

A solution of 6-chloro- α -(2,6-dichlorophenyl)-3-pyridazineacetonitrile (**51**) (149 mg, 0.5 mmol), 2,4-difluorothiophenol (**45b**) (73 mg, 0.056 mL, 0.55 mmol) Pd(OAc)₂ (6 mg, 0.025 mmol), XantPhos (579 mg, 1 mmol) and NaOtBu (96 mg, 1 mmol) in dry toluene (2 mL) was irradiated at 150 °C in a pressure-rated glass tube (10 mL) for 1 h by moderating the initial power (150 W). The reaction mixture was filtered on celite and evaporated *in vacuo*. Purification by column chromatography on SiO₂, eluting with hexane–Et₂O (3:1) gave the title compound (89 mg, 44%) as orange needles, mp 122–124 °C (lit.¹⁴⁸ 124–131 °C) (found: MH⁺, 407.9940. C₁₈H₁₀N₃SCl₂F₂ requires [MH] 407.9941); ¹H NMR (400 MHz; CDCl₃) δ 7.51–7.58 (1H), 7.32 (1H, d), 7.3 (1H), 7.19–7.24 (3H, m), 6.87–6.93 (2H, m), 6.35 (1H, s), 5.23 (1H, s); ¹³C NMR (125 MHz; CDCl₃) δ 162.3 (C), 153.4 (C), 138.5 (C), 138.4 (C), 136 (C), 130.9 (C), 129.8 (CH), 129.3 (C), 125.2 (CH), 125 (CH), 115.4 (CH), 112.8 (CH), 112.7 (CH), 112.6 (C), 105.6 (C), 105.4 (CH), 105.2 (CH), 38.5 (CH); MS (AP) *m/z* (rel. intensity) 408 (MH⁺, 100).

α -(2,6-Dichlorophenyl)-6-[(2,4-difluorophenyl)thio]-3-pyridazineacetonitrile (52b)

(Table 35, entry 3). A solution of 6-chloro- α -(2,6-dichlorophenyl)-3-pyridazineacetonitrile (**51**) (149 mg, 0.5 mmol), 2,4-difluorothiophenol (**45b**) (73 mg, 0.056 mL, 0.55 mmol) PEPPSITM-*i*Pr (7 mg, 0.01 mmol) and NaOtBu (72 mg, 0.75 mmol) in dry toluene (2 mL) was irradiated at 150 °C in a pressure-rated glass tube (10 mL) for 1 h by moderating the initial power (120 W). The reaction mixture was filtered on celite and evaporated *in vacuo*. Purification by column chromatography on SiO₂, eluting with hexane–Et₂O (3:1) gave the title compound (153 mg, 75%) as an orange solid, with identical physical and spectroscopic properties.

α -(2,6-Dichlorophenyl)-6-[(2,4-difluorophenyl)thio]-3-pyridazineacetonitrile (52b)

(Table 35, entry 4). A solution of 6-chloro- α -(2,6-dichlorophenyl)-3-pyridazineacetonitrile (**51**) (149 mg, 0.5 mmol), 2,4 difluorothiophenol (**45b**) (73 mg, 0.056 mL, 0.55 mmol), PEPPSITM-*i*Pr (7 mg, 0.01 mmol), LiCl (4.5 mg, 0.1 mmol) and NaOtBu (72 mg, 0.75 mmol)

in dry toluene (2 mL) was irradiated at 120 °C in a pressure-rated glass tube (10 mL) for 3 × 1 h by moderating the initial power (150 W). The reaction mixture was filtered on celite and evaporated *in vacuo*. Purification by column chromatography on SiO₂, eluting with hexane–Et₂O (3:1) gave the title compound (147 mg, 72%) as an orange solid, with identical physical and spectroscopic properties.

α -(2,6-Dichlorophenyl)-6-[(2,4-difluorophenyl)thio]-3-pyridazineacetonitrile (52b)

(Table 35, entry 5). A solution of 6-chloro- α -(2,6-dichlorophenyl)-3-pyridazineacetonitrile (**51**) (149 mg, 0.5 mmol), 2,4-difluorothiophenol (**45b**) (73 mg, 0.056 mL, 0.55 mmol) and NaOtBu (72 mg, 0.75 mmol) in dry toluene (2 mL) was irradiated at 150 °C in a pressure-rated glass tube (10 mL) for 1 h by moderating the initial power (120 W). The reaction mixture was filtered on celite and evaporated *in vacuo*. Purification by column chromatography on SiO₂, eluting with hexane–Et₂O (3:1) gave the title compound (111 mg, 54%) as an orange solid, with identical physical and spectroscopic properties.

α -(2,6-dichlorophenyl)-6-[(2,4-difluorophenyl)thio]-3-pyridazineacetonitrile (52b) (Table 35, entry 6).

A solution of 6-chloro- α -(2,6-dichlorophenyl)-3-pyridazineacetonitrile (**51**) (149 mg, 0.5 mmol), 2,4 difluorothiophenol (**45b**) (73 mg, 0.056 mL, 0.55 mmol) and NaOtBu (96 mg, 1 mmol) in dry toluene (2 mL) was irradiated at 120 °C in a pressure-rated glass tube (10 mL) for 3 × 1 h by moderating the initial power (150 W). The reaction mixture was filtered on celite and evaporated *in vacuo*. Purification by column chromatography on SiO₂, eluting with hexane–Et₂O (3:1) gave the title compound (142 mg, 69%) as an orange solid, with identical physical and spectroscopic properties.

α -(2,6-dichlorophenyl)-6-[(2,4-difluorophenyl)thio]-3-pyridazineacetonitrile (52b) (Table 35, entry 7).

A solution of 6-chloro- α -(2,6-dichlorophenyl)-3-pyridazineacetonitrile (**51**) (149 mg, 0.5 mmol), 2,4-difluorothiophenol (**45b**) (73 mg, 0.056 mL, 0.55 mmol), CuI (9.5 mg, 0.05 mmol), neocuproine (10 mg, 0.05 mmol) and NaOtBu (72 mg, 0.75 mmol) in dry toluene (2 mL) was irradiated at 120 °C in a pressure-rated glass tube (10 mL) for 3 × 1 h by moderating the initial power (150 W). The reaction mixture was filtered on celite and evaporated *in vacuo*. Purification by column chromatography on SiO₂, eluting with hexane–Et₂O (3:1) gave the title compound (161 mg, 79%) as an orange solid, with identical physical and spectroscopic properties.

α -(2,6-dichlorophenyl)-6-[(2,4-difluorophenyl)thio]-3-pyridazineacetonitrile (52b) (Table 35, entry 8). A solution of 6-chloro- α -(2,6-dichlorophenyl)-3-pyridazineacetonitrile (**51**) (149 mg, 0.5 mmol), 2,4 difluorothiophenol (**45b**) (73 mg, 0.056 mL, 0.55 mmol), neocuproine (10 mg, 0.05 mmol) and NaOtBu (72 mg, 0.75 mmol) in dry toluene (2 mL) was irradiated at 120 °C in a pressure-rated glass tube (10 mL) for 3 × 1 h by moderating the initial power (150 W). The reaction mixture was filtered on celite and evaporated *in vacuo*. Purification by column chromatography on SiO₂, eluting with hexane–Et₂O (3:1) gave the title compound (176 mg, 86%) as an orange solid, with identical physical and spectroscopic properties.

α -(2,6-Dichlorophenyl)-6-[(2,4-difluorophenyl)thio]-3-pyridazineacetonitrile (52b) (Table 36, entry 1). A solution of 6-chloro- α -(2,6-dichlorophenyl)-3-pyridazineacetonitrile (**51**) (150 mg, 0.5 mmol) and 2,4-difluorothiophenol (**45b**) (57 μ L, 0.5 mmol) was reacted according to general procedure 5.2.7 to give the title compound (186 mg, 91%) as an orange solid with identical physical and spectroscopic properties.

α -(2,6-Dichlorophenyl)-6-[(2,4-difluorophenyl)thio]-3-pyridazineacetonitrile (52b) (Table 36, entry 2). A solution of 6-chloro- α -(2,6-dichlorophenyl)-3-pyridazineacetonitrile (**51**) (150 mg, 0.5 mmol) 2,4-difluorothiophenol (**45b**) (57 μ L, 0.5 mmol), (\pm)-*trans*-cyclohexane-1,2-diol (118 mg, 1.0 mmol), K₂CO₃ (140 mg, 1.0 mmol) in 2-propanol (3 mL) was irradiated at 120 °C in a pressure-rated glass tube (10 mL) for 3 × 1 h by moderating the initial power (150 W). The reaction mixture was filtered on SiO₂ and evaporated *in vacuo*. Purification by column chromatography on SiO₂, eluting with hexane–Et₂O (1:5 to 1:1), gave the title compound (194 mg, 95%) as an orange solid, with identical physical and spectroscopic properties.

α -(2,6-Dichlorophenyl)-6-[(2,4-difluorophenyl)thio]-3-pyridazineacetonitrile (52b) (Table 36, entry 3). A solution of 6-chloro- α -(2,6-dichlorophenyl)-3-pyridazineacetonitrile (**51**) (150 mg, 0.5 mmol) 2,4-difluorothiophenol (**45b**) (57 μ L, 0.5 mmol), K₂CO₃ (140 mg, 1.0 mmol) in 2-propanol (3 mL) was irradiated at 120 °C in a pressure-rated glass tube (10 mL) for 3 × 1 h by moderating the initial power (150 W). The reaction mixture was filtered on SiO₂ and evaporated *in vacuo*. Purification by column chromatography on SiO₂, eluting with hexane–Et₂O (1:5 to 1:1), gave the title compound (128 mg, 63%) as an orange solid, with identical physical and spectroscopic properties.

3,6-Bis(phenylthio)pyridazine (54) (Table 33, entry 1).

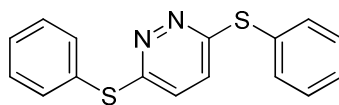

A solution of 3,6-dichloropyridazine (**50**) (149 mg, 1.0 mmol), thiophenol (**45a**) (107 mg, 0.10 mL, 1.0 mmol), PEPPSITM-*i*Pr (13 mg, 0.02 mmol), LiCl (9 mg, 20 mol%) and NaOtBu (144 mg, 1.5 mmol) in dry PhMe (2 mL) was irradiated at 120 °C in a pressure-rated glass tube (10 mL) for 3 × 1 h by moderating the initial power (150 W). After cooling in a flow of compressed air, the reaction mixture was filtered and evaporated *in vacuo*. Purification by column chromatography on SiO₂, eluting with light petroleum–CH₂Cl₂ (1:1), gave the title compound (124 mg, 42%) as a brown oil (found: M⁺, 296.0453. C₁₆H₁₂N₂S₂ [M] requires 296.0442); ¹H NMR (400 MHz; *d*₆-DMSO) δ 7.61–7.58 (4H, m), 7.51–7.48 (6H), 7.19 (2H, s); ¹³C NMR (125 MHz; *d*₆-DMSO) δ 161.3 (C), 134.5 (C), 129.9 (CH), 129.6 (CH), 128.7 (CH), 126.4 (CH); MS (EI) *m/z* (rel. intensity) 296 (M⁺, 30%), 109 (22).

3,6-Bis(phenylthio)pyridazine (54) (Table 33, entry 2). A solution of 3,6-dichloropyridazine (**50**) (149 mg, 1.0 mmol), thiophenol (**45a**) (107 mg, 0.10 mL, 1.0 mmol), PEPPSITM-*i*Pr (13 mg, 0.02 mmol) and NaOtBu (144 mg, 1.5 mmol) in dry PhMe (2 mL) was irradiated at 120 °C in a pressure-rated glass tube (10 mL) for 3 × 1 h by moderating the initial power (150 W). After cooling in a flow of compressed air, the reaction mixture was filtered and evaporated *in vacuo*. Purification by column chromatography on SiO₂, eluting with light petroleum–CH₂Cl₂ (1:1), gave the title compound (124 mg, 82%) as a brown oil with identical physical and spectroscopic properties.

3,6-Bis(phenylthio)pyridazine (54) (Table 33, entry 3). A solution of 3,6-dichloropyridazine (**50**) (149 mg, 1.0 mmol), thiophenol (107 mg, 0.10 mL, 1.0 mmol), CuI (19 mg, 0.10 mmol), neocuproine (20 mg, 0.10 mmol) and NaOtBu (144 mg, 1.5 mmol) in dry PhMe (2 mL) was irradiated at 120 °C for 3 × 1 h in a pressure-rated glass tube (10 mL) using a CEM Discover® microwave synthesiser by moderating the initial power (150 W). After cooling in a flow of compressed air, the reaction mixture was filtered and evaporated *in vacuo*. Purification by column chromatography on SiO₂, eluting with light petroleum–CH₂Cl₂ (1:1), gave the title compound (95 mg, 64%) as a brown oil, with identical physical and spectroscopic properties.

3,6-Bis(phenylthio)pyridazine (54) (Table 33, entry 4). A solution of 3,6-dichloropyridazine (**50**) (149 mg, 1.0 mmol) and thiophenol (107 mg, 0.10 mL, 1.0 mmol) was reacted according to general procedure 5.2.7 to give the title compound (52 mg, 35%) as a brown oil, with identical physical and spectroscopic properties.

3,6-Bis(phenylthio)pyridazine (54) (Table 33, entry 5). A solution of 3,6-dichloropyridazine (**50**) (149 mg, 1.0 mmol), thiophenol (107 mg, 0.10 mL, 1.0 mmol) and NaOtBu (144 mg, 1.5 mmol) in dry PhMe (2 mL) was irradiated at 120 °C for 3 × 1 h in a pressure-rated glass tube (10 mL) using a CEM Discover® microwave synthesiser by moderating the initial power (150 W). After cooling in a flow of compressed air, the reaction mixture was filtered and evaporated *in vacuo*. Purification by column chromatography on SiO₂, eluting with light petroleum–CH₂Cl₂ (1:1), gave the title compound (117 mg, 79%) as a brown oil, with identical physical and spectroscopic properties.

2-[(Phenylmethyl)thio]pyridine (55a) (Table 37, entry 2).

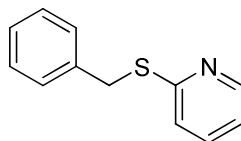

A solution of 2-chloropyridine (**39n**) (124 mg, 1.1 mmol), benzyl-mercaptan (**45l**) (124 mg, 1 mmol), Cu nanopowder (13 mg, 0.2 mmol) and K₂CO₃ (276 mg, 2 mmol) in DMF (0.8 mL) was irradiated at 120 °C in a pressure-rated glass tube (10 mL) for 1.5 h by moderating the initial power (150 W). The reaction mixture was filtered and evaporated *in vacuo*. Purification by column chromatography on SiO₂, eluting with hexane–CH₂Cl₂ (3:1) gave the title compound (104 mg, 52%) as a yellow solid, mp 30 °C (found: M⁺, 201.0605. C₁₂H₁₁NS requires [M] 216.0612); ¹H NMR (400 MHz; *d*₆-DMSO) δ 8.45 (H, ddd, *J* 5, 2, 1), 7.47 (1H, ddd, *J* 8.2, 7.3, 1), 7.42-7.28 (5H, m), 7.15 (1H, dd, *J* 5, 1), 6.95 (1H, ddd, *J* 7, 5, 1), 4.34 (2H, s); ¹³C NMR (400 MHz; *d*₆-DMSO) δ 159 (C), 150.5 (CH), 138.9 (C), 136.8 (CH), 130.4 (CH), 129.1 (CH), 127.3 (CH), 123.1 (CH), 118.5 (CH), 35.2 (CH); MS (EI) *m/z* (rel. intensity) 201 (M⁺, 68), 168 (100).

2-[(Phenylmethyl)thio]pyridine (55a) (Table 38, entry 4). A solution of 2-chloropyridine (**39n**) (57 mg, 0.5 mmol) and benzyl-mercaptan (**45l**) (68 mg, 0.5 mmol) was reacted

according to general procedure 5.2.7 to give the title compound (100 mg, 50%) as a yellow solid, with identical physical and spectroscopic properties.

2-[(2,5-Dimethyl)phenylmethylthio]pyridine (55b) (Table 37, entry 3).

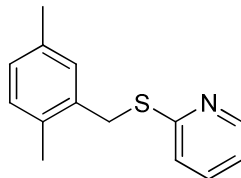

A solution of 2,5-dimethylbenzylchloride (**39o**) (170 mg, 1.1 mmol), 2-mercaptopyridine (**45m**) (111 mg, 1 mmol), Cu nanopowder (13 mg, 0.2 mmol) and K_2CO_3 (276 mg, 2 mmol) in DMF (0.8 mL) was irradiated at 120 °C in a pressure-rated glass tube (10 mL) for 2 × 1 h by moderating the initial power (250 W). The reaction mixture was filtered and evaporated *in vacuo*. Purification by column chromatography on SiO_2 , eluting with hexane- CH_2Cl_2 (3:1) gave the title compound (185 mg, 81%) as a yellow solid, mp 78 °C; (found: M^+ , 229.0926. $C_{14}H_{15}NS$ requires [M] 229.0925); 1H NMR (400 MHz; d_6 -DMSO) δ 8.15 (2H, dt, J 9.1), 7.59–7.62 (2H, m), 7.53–7.57 (3H, m), 7.29 (2H, dt, J 9.1); ^{13}C NMR (100 MHz; d_6 -DMSO) δ 148 (C), 145.5 (C), 134.9 (C), 130.8 (CH), 130.4 (CH), 130.1 (CH), 127.3 (CH), 124.8 (CH); MS (EI) m/z (rel. intensity) 229 (M^+ , 100), 196 (89), 111 (100).

2-[(2,5-Dimethyl)phenylmethylthio]pyridine (55b) (Table 37, entry 4). A solution of 2,5-dimethylbenzylchloride (**39o**) (170 mg, 1.1 mmol), 2-mercaptopyridine (**45m**) (111 mg, 1 mmol) and K_2CO_3 (276 mg, 2 mmol) in DMF (0.8 mL) was irradiated at 120 °C in a pressure-rated glass tube (10 mL) for 2 × 1 h by moderating the initial power (250 W). The reaction mixture was filtered and evaporated *in vacuo*. Purification by column chromatography on SiO_2 , eluting with hexane- CH_2Cl_2 (3:1) gave the title compound (144 mg, 63%) as a yellow solid, with identical physical and spectroscopic properties.

2-[(2,5-Dimethyl)phenylmethylthio]pyridine (55b) (Table 38, entry 2). A solution of 2,5-dimethylbenzylchloride (**39o**) (170 mg, 1.1 mmol), 2-mercaptopyridine (**45m**) (111 mg, 1 mmol), CuI (10 mg, 0.05 mmol), ethylene-glycol (124 mg, 2 mmol) and K_2CO_3 (276 mg, 2 mmol) in 2-propanol (2 mL) was irradiated at 120 °C in a pressure-rated glass tube (10 mL) for 2 × 1 h by moderating the initial power (250 W). The reaction mixture was filtered and evaporated *in vacuo*. Purification by column chromatography on SiO_2 , eluting with hexane-

CH₂Cl₂ (3:1) gave the title compound (169 mg, 74%) as a yellow solid, with identical physical and spectroscopic properties.

4-(Benzyl)sulfanylanisole (55c) (Table 38, entry 3).

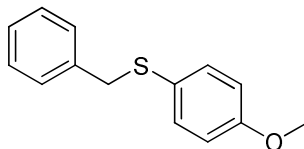

A solution of 4-iodoanisole (**39a**) (117 mg, 0.5 mmol) and benzyl-mercaptan (**45I**) (68 mg, 0.5 mmol) was reacted according to general procedure 5.2.7 to give the title compound (66 mg, 66%) as a pale yellow solid; ¹H NMR (400 MHz; *d*₆-DMSO) δ 7.29–7.19 (5H, m), 6.85 (2H, app dt, *J* 8.8), 4.1 (2H, s), 3.72 (3H, s); ¹³C NMR (100 MHz; *d*₆-DMSO) δ 157 (C), 140 (C), 129.4 (CH), 128.2 (CH), 127.4 (CH), 116.1 (CH), 58.3 (CH), 40.3 (CH).

References

- ¹ (a) Kappe, C. O.; Dallinger, D.; Murphree, S. S. *Practical microwave synthesis for organic chemists—strategies instruments and protocols*; Wiley–VCH: Weinheim, 2009; (b) Kappe, C. O.; Sandler, A. *Microwave in Organic and Medicinal Chemistry*; Wiley–VCH: Weinheim, 2005; (c) Tierney, J. P.; Lidström, P. (eds) *Microwave Assisted Organic Synthesis*; Blackwell: Oxford, 2005; (d) Varma, R. S. *Advances in Green Chemistry: Chemical Syntheses Using Microwave Irradiation*; Astra Zeneca Research Foundation, Kavitha Printers: Bangalore, India, 2002; (e) Loupy, A. (ed.) *Microwave in Organic Synthesis*; Wiley–VCH: Weinheim, 2002; (f) Larhed, M.; Olofsson, K. (eds) *Microwave Methods in Organic Synthesis*; Springer: Berlin, 2006; (g) Hayes, B. L. *Microwave Synthesis: Chemistry at the Speed of Light*; CEM Publishing, Matthews: NC, 2002.
- ² Lubinu, M. C. *Microwave-mediated synthesis of N-containing heterocycles: from batch to continuous flow processes*. PhD thesis, Cardiff University, Cardiff, 2007.
- ³ Baghurst, D. R.; Mingos, D. M. P. *Chem. Soc. Rev.* **1991**, 20, 1.
- ⁴ Schmink, J. R.; Leadbeater, N.E. *Org. Biomol. Chem.* **2009**, 7, 3842.
- ⁵ Hayes, B. L. *Alrichimica Acta* **2004**, 37, 66.
- ⁶ (a) Obermayer, D.; Gutmann, B.; Kappe, C. O. *Angew. Chem. Int. Ed.* **2009**, 48, 8321; (b) Kreamer, J. M.; Kappe, C.O. *J. Org. Chem.* **2006**, 71, 4651.
- ⁷ <http://www.rsc.org/chemistryworld/News/2009/October/02100902.asp>.
- ⁸ Strauss, C. R. *Org. Proc. Res. Dev.* **2009**, 13, 915.
- ⁹ Strauss, C. R. *Aust. J. Chem.* **2009**, 62, 3.
- ¹⁰ Caddick, S.; Fitzmaurice, R. *Tetrahedron* **2009**, 65, 3325.
- ¹¹ (a) Katritzky, A. R.; Khashab, N. M.; Yoshioka, M.; Haase, D. N.; Wilson, K. R.; Johnson, J. V.; Chung, A.; Haskell-Leuvano, C. *Chem. Biol. Drug Des.* **2007**, 70, 465; (b) Erdelyi, M.; Gogoll, A. *Synthesis* **2002**, 1592; (c) Bacsa, B.; Desai, B.; Dibo, G.; Kappe, C. O. *J. Pept. Sci.* **2006**, 12, 633; (d) Bacsa, B.; Kappe, C. O. *Nat. Protoc.* **2007**, 2, 2222; (e) Murray, J. K.; Farooqi, B.; Sadowsky, J. D.; Scaff, M.; Freund, W. A.; Smith, L. M.; Chen, J. D.; Gellman, S. H. *J. Am. Chem. Soc.* **2005**, 127, 13271; (f) Murray, J. K.; Gellman, S. H. *J. Comb. Chem.* **2006**, 8, 58; (g) Murray, J. K.; Gellman, S. H. *Nat. Protoc.* **2007**, 2, 624; (h) Petersson, E. J.; Schepartz, A. *J. Am. Chem. Soc.* **2008**, 130, 821.
- ¹² Lill, J. R. (ed.) *Microwave-Assisted Proteomics*; RSC Publishing: Cambridge, 2009.
- ¹³ Kappe, C. O. *Angew. Chem. Int. Ed.* **2004**, 43, 6250.
- ¹⁴ Kappe, C. O.; Dallinger, D. *Mol. Divers.* **2009**, 13, 71.
- ¹⁵ (a) Maitlis, P. M. *The Organic Chemistry of Palladium*; Academic Press: New York, 1971; Vols. 1 and 2; (b) Tsuji, J. *Palladium Reagents and Catalysts: Innovations in Organic Synthesis*; Wiley and Sons: New York, 1995; (c) Tsuji, J. *Palladium Reagents and Catalysts: New Perspectives for the 21st Century*; Wiley and Sons: New York, 2004; (d) Li, J. J.; Gribble, G. W. *Palladium in Heterocyclic Chemistry*; Pergamon: New York, 2000; (e) Negishi, E. *Handbook of Organopalladium Chemistry for Organic Synthesis*; Wiley and Sons: New York, 2002; Vols. 1 and 2; (f) Zeni, G.; Larock, R. C. *Chem. Rev.* **2006**, 106, 4644; and references therein; (g) Special issue on cross-coupling *Acc. Chem. Res.* **2008**, 41, 1439.
- ¹⁶ Chinchilla, R.; Nájera, C. *Chem. Rev.* **2007**, 107, 874.
- ¹⁷ Prim, D.; Campagne, J. M.; Joseph, D.; Andrioletti, B. *Tetrahedron* **2002**, 58, 2041.
- ¹⁸ Grushin, V. V. *Chem. Eur. J.* **2002**, 8, 1006.
- ¹⁹ Daugulis, O.; Do, H.-Q.; Shabashov, D. *Acc. Chem. Res.* **2009**, 1074.
- ²⁰ Krause, N. *Modern Organocopper Chemistry*; Wiley-VCH: Weinheim, 2002; Beletskaya, I. P.; Cheprakov, A. V. *Coord. Chem. Rev.* **2004**, 2337; and references therein; Evano, G.; Blanchard, N.; Toumi, M. *Chem. Rev.* **2008**, 108, 3054; Ley, S. V.; Thomas, A. W. *Angew. Chem. Int. Ed.* **2003**, 42, 5400.
- ²¹ Kolb, H. C.; Finn, M. G.; Sharpless, B. *Angew. Chem. Int. Ed.* **2001**, 40, 2004; Kolb, H. C.; Sharpless, B. *Drug Disc. Today* **2003**, 8, 1128; Moses, J. E.; Moorhouse, A. D. *Chem. Soc. Rev.* **2007**, 36, 1249; Bock, V. D.; Hiemstra, H.; van Maarseveen, J. H. *Eur. J. Org. Chem.* **2006**, 51; Boren, B. C.; Narayan, S.; Rasmussen, L. K.; Zhang, L.; Zhao, H.; Lin, Z.; Jia, G.; Fokin, V. V. *J. Am. Chem. Soc.* **2008**, 130, 8923.
- ²² Huisgen, R.; Szeimies, G.; Möbius, L. *Chem. Ber.* **1967**, 100, 2494.
- ²³ Derdau, V.; Atzrodt, J.; Zimmermann, J.; Kroll, C.; Brückner, F. *Chem. Eur. J.* **2009**, 15, 10397.
- ²⁴ Hull, K. L.; Anani, W. Q.; Sanford, M. S. *J. Am. Chem. Soc.* **2006**, 128, 7134.
- ²⁵ Awuah, E.; Capretta, A. *Org. Lett.* **2009**, 11, 3210.
- ²⁶ Adjabeng, G.; Brenstrum, T.; Frampton, C. S.; Robertson, A. J.; Hillhouse, J.; McNulty, J.; Capretta, A. *J. Org. Chem.* **2004**, 69, 5082.
- ²⁷ Nájera, C.; Alacid, E. *J. Org. Chem.* **2008**, 73, 2315.
- ²⁸ Huang, T.; Li, C.-J. *Tetrahedron Lett.* **2002**, 43, 403; Koike, T.; Mori, A. *Synlett* **2003**, 1850; Wolf, C.; Lerebours, R. *Org. Lett.* **2004**, 6, 1147; Wolf, C.; Lerebours, R. *Synthesis* **2005**, 2287.
- ²⁹ Arvela, R. K.; Leadbeater, N. E. *Org. Lett.* **2005**, 7, 2101.

- ³⁰ Lépine, R.; Zhu, J. *Org. Lett.* **2005**, *7*, 2981.
- ³¹ Baxendale, I. R.; Griffiths-Jones, C. M.; Ley, S. V.; Tranmer, G. K. *Chem. Eur. J.* **2006**, *12*, 4407.
- ³² Fitzmaurice, R. J.; Etheridge, Z. C.; Jumel, E.; Woolfson, D. N.; Caddick, S. *Chem. Commun.* **2006**, 4814.
- ³³ Nájera, C.; Alacid, E. *Org. Lett.* **2008**, *10*, 5011.
- ³⁴ Kim, Y. H.; Lee, H.; Kim, Y. J.; Kim, B. T.; Heo, J. N. *J. Org. Chem.* **2008**, *73*, 495.
- ³⁵ Cao, P.; Qu, J.; Burton, G.; Rivero, R. A. *J. Org. Chem.* **2008**, *73*, 7204.
- ³⁶ Kim, D.-S.; Ham, J. *Org. Lett.* **2010**, *12*, 1092.
- ³⁷ Lindh, J.; Enquist, P.; Pilotti, A.; Nilsson, P.; Larhed, M. *J. Org. Chem.* **2007**, *72*, 7957.
- ³⁸ Venturini, A. M.; Sega, F. P. C.; Roque, C. D. C. *Org. Lett.* **2009**, *11*, 3642.
- ³⁹ Shore, G.; Morin, S.; Organ, M. G. *Angew. Chem. Int. Ed.* **2006**, *45*, 2761.
- ⁴⁰ Kalek, M.; Ziadi, A.; Stawinski, J. *Org. Lett.* **2008**, *10*, 4637.
- ⁴¹ Kalek, M.; Stawinski, J. *Organometallics* **2007**, *26*, 5840; Kalek, M.; Stawinski, J. *Organometallics* **2008**, *27*, 5876.
- ⁴² Andaloussi, M.; Lindh, J.; Savmarker, J.; Sjöberg, P. J. R.; Larhed, M. *Chem. Eur. J.* **2009**, *15*, 13069.
- ⁴³ Wu, X.; Larhed, M. *Org. Lett.* **2005**, *7*, 3327.
- ⁴⁴ Roberts, B.; Liptrot, D.; Alcaraz, L. *Org. Lett.* **2010**, *12*, 1264.
- ⁴⁵ Burton, G.; Cao, P.; Li, G.; Rivero, R. *Org. Lett.* **2003**, *5*, 4373.
- ⁴⁶ Wang, T.; Magnin, D. R.; Hamann, L. G. *Org. Lett.* **2003**, *5*, 897.
- ⁴⁷ Fields, W.; Chruma, J. *Org. Lett.* **2010**, *12*, 316.
- ⁴⁸ Lautens, M.; Tayama, E.; Herse, C. *J. Am. Chem. Soc.* **2005**, *127*, 72.
- ⁴⁹ Mariampillai, B.; Alliot, J.; Li, M.; Lautens, M. *J. Am. Chem. Soc.* **2007**, *129*, 15372.
- ⁵⁰ Navarro, O.; Marion, N.; Oonishi, Y.; Kelly, R. A.; Nolan, S. *J. Org. Chem.* **2006**, *71*, 685.
- ⁵¹ Schmink, J. R.; Leadbeater, N. E. *Org. Lett.* **2009**, *11*, 2575.
- ⁵² Wannberg, J.; Dallinger, D.; Kappe, C. O.; Larhed, M. *J. Comb. Chem.* **2005**, *7*, 574.
- ⁵³ Wannberg, J.; Larhed, M. *J. Org. Chem.* **2003**, *68*, 5750.
- ⁵⁴ Shi, B.; Lewis, W.; Campbell, I. B.; Moody, C. J. *Org. Lett.* **2009**, *11*, 3686.
- ⁵⁵ Bosch, L.; Vilarrasa, J. *Angew. Chem. Int. Ed.* **2007**, *46*, 3926.
- ⁵⁶ Özçubukçu, S.; Ozkal, E.; Jimeno, C.; Pericàs, M. A. *Org. Lett.* **2009**, *11*, 4680.
- ⁵⁷ Lipshutz, B. H.; Taft, B. R. *Angew. Chem. Int. Ed.* **2006**, *45*, 8235.
- ⁵⁸ Buckley, B. R.; Dann, S. E.; Harris, D. P.; Heaney, H.; Stubbs, E. C. *Chem. Commun.* **2010**, 46, 2274.
- ⁵⁹ Miller, N.; Williams, G. M.; Brimble, M. A. *Org. Lett.* **2009**, *11*, 2409.
- ⁶⁰ Liu, Y.; Yan, W.; Chen, Y.; Petersen, J. L.; Shi, X. *Org. Lett.* **2008**, *10*, 5389.
- ⁶¹ Do, H.-Q.; Kashif Khan, R. M.; Daugulis, O. *J. Am. Chem. Soc.* **2008**, *130*, 15185; Do, H.-Q.; Daugulis, O. *J. Am. Chem. Soc.* **2008**, *130*, 1128; Do, H.-Q.; Daugulis, O. *J. Am. Chem. Soc.* **2007**, *129*, 12404.
- ⁶² Yotphan, S.; Bergman, R. G.; Ellmann, J. A. *Org. Lett.* **2009**, *11*, 1511.
- ⁶³ Viirre, R. D.; Evindar, G.; Batey, R. A. *J. Org. Chem.* **2008**, *73*, 3452.
- ⁶⁴ Röttger, S.; Sjöberg, P. J. R.; Larhed, M. *J. Comb. Chem.* **2007**, *9*, 204.
- ⁶⁵ Guo, D.; Huang, H.; Zhou, Y.; Xu, J.; Jiang, H.; Chen, K.; Liu, H. *Green Chem.* **2010**, *12*, 276.
- ⁶⁶ Lipshutz, B. H.; Nihan, D. M.; Vinogradova, E.; Taft, B. R.; Boskovic, Z. V. *Org. Lett.* **2008**, *10*, 4279.
- ⁶⁷ Lipshutz, B. H.; Frieman, B. A.; Lee, C.-T.; Lower, A.; Nihan, D. M.; Taft, B. R. *Chem. Asian J.* **2006**, *1*, 417.
- ⁶⁸ Xu, H.; Wolf, C. *Chem. Commun.* **2009**, 45, 3035.
- ⁶⁹ Shore, G.; Yoo, W.-J.; Li, C.-J.; Organ, M. G. *Chem. Eur. J.* **2010**, *16*, 126.
- ⁷⁰ Pereshivko, O. P.; Peshkov, V. A.; Van der Eycken, E. V. *Org. Lett.* **2010**, *12*, 2638.
- ⁷¹ Besselièvre, F.; Mahuteau-Betzer, F.; Grierson, D. S.; Piguel, S. *J. Org. Chem.* **2008**, *73*, 3278.
- ⁷² Prokopcova, H.; Kappe, C. O. *J. Org. Chem.* **2007**, *72*, 4440.
- ⁷³ Goossen, L. J.; Linder, C.; Rodriguez, N.; Lange, P. P. *Chem. Eur. J.* **2009**, *15*, 9336.
- ⁷⁴ Willy, B.; Frank, W.; Müller, T. J. *J. Org. Biomol. Chem.* **2010**, *8*, 90.
- ⁷⁵ Microreactor Technology *ChemFiles* **2009**, *9*, 4.
- ⁷⁶ Wirth, T. *Microreactors in Organic Synthesis and Catalysis*. Wiley-VCH: Weinheim, 2008.
- ⁷⁷ Thematic series 4: Chemistry in flow systems, *Beilstein J. Org. Chem.* **2009**, *5*.
- ⁷⁸ Razzaq, T.; Glasnov, T. N.; Kappe, C. O. *Eur. J. Org. Chem.* **2009**, 1321.
- ⁷⁹ From Geyer, K.; Seeberger, P.H. *Proceedings of "Systems Chemistry"*, May 26th – 30th, **2008**, Bozen, Italy.
- ⁸⁰ Nieuwland P. J.; Koch K.; Van Harskamp N.; Wehrens R.; Van Hest J. C.; Rutjes F. P. *Chem. Asian J.* **2010**, *5*, 799; <http://www.futurechemistry.com/flow-chemistry.html>.
- ⁸¹ Sedelmeier, J.; Ley, S. V.; Baxendale, I. R. *Green Chem.* **2009**, *11*, 683; <http://www.thalesnano.com/>.
- ⁸² Palmieri, A.; Ley, S. V.; Polyzos, A.; Ladlow, M.; Baxendale, I. R. *Beilstein J. Org. Chem.* **2009**, *5*, 23; <http://www.uniqls.com/>.
- ⁸³ Riva, E.; Gagliardi, S.; Martinelli, M.; Passarella, D.; Vigo, D.; Rencurosi, A. *Tetrahedron* **2010**, *66*, 3242; <http://www.vapourtec.co.uk/home>.
- ⁸⁴ Wiles, C.; Watts, P. *Beilstein J. Org. Chem.* **2011**, *7*, 1360; <http://www.chemtrix.com/>.

- ⁸⁵ Chun, J.-H.; Lu, S.; Lee, Y.-S.; Pike, V. W. *J. Org. Chem.* **2010**, *75*, 3332; <http://www.advion.com/>.
- ⁸⁶ Tinder, R.; Farr, R.; Heid, R.; Zhao, R.; Rarig, R. S. Jr; Storz, T. *Org. Proc. Res. Dev.* **2009**, *13*, 1401; <http://www.syrtris.com/>.
- ⁸⁷ Bagley, M. C.; Jenkins, R. L.; Lubinu, M. C.; Mason, C.; Wood, R. *J. Org. Chem.* **2005**, *70*, 7003.
- ⁸⁸ (a) Moseley, J. D.; Lawton, S. J. *Chim. Oggi* **2007**, *25*, 16; (b) Bowman, M. D.; Holcomb, J. L.; Kormos, C. M.; Leadbeater, N. E.; Williams, V. A. *Org. Proc. Res. Dev.* **2008**, *12*, 41; (c) Dressen, M. H. C. L.; van de Kruijs, B. H. P.; Meuldijk, J.; Vekemans, J. A. J. M.; Hulshof, L. A. *Org. Proc. Res. Dev.* **2010**, *14*, 351.
- ⁸⁹ (a) Favretto, L. *Mol. Diversity* **2003**, *7*, 287; (b) Loones, K. T. J.; Maes, B. U. W.; Rombouts, G.; Hostyn, S.; Diels, G. *Tetrahedron* **2005**, *61*, 10338.
- ⁹⁰ Hartung, A.; Keane, M. A.; Kraft, A. *J. Org. Chem.* **2007**, *72*, 10235.
- ⁹¹ Bogdan, A. R.; Poe, S. L.; Kubis, D. C.; Broadwater, S. J.; McQuade, D. T. *Angew. Chem. Int. Ed.* **2009**, *48*, 8547.
- ⁹² Herath, A.; Dahl, R.; Cosford, N. D. P. *Org. Lett.* **2010**, *12*, 412.
- ⁹³ Riva, E.; Gagliardi, S.; Mazzoni, C.; Passarella, D.; Rencurosi, A.; Vigo, D.; Martinelli, M. *J. Org. Chem.* **2009**, *74*, 3540.
- ⁹⁴ Brandt, J. C.; Wirth, T. *Beilstein J. Org. Chem.* **2009**, *5*, 30.
- ⁹⁵ Sahoo, H. R.; Kralj, J. G.; Jensen, K. F. *Angew. Chem. Int. Ed.* **2007**, *46*, 5704.
- ⁹⁶ Carrel, F. R.; Geyer, K.; Codée, J. D. C.; Seeberger, P. H. *Org. Lett.* **2007**, *9*, 2285.
- ⁹⁷ Bedore, M. W.; Zaborenko, N.; Jensen, K. F.; Jamison, T. F. *Org. Proc. Res. Dev.* **2010**, *14*, 432.
- ⁹⁸ Anastas, P.; Warner, J. *Green Chemistry: Theory and Practice*; Oxford University Press: New York, 1998.
- ⁹⁹ Joule, J. A.; Mills, K. *Heterocyclic chemistry*; Wiley-Blackwell Publishing: Oxford, 2010.
- ¹⁰⁰ (a) Bagley, M. C.; Glover, C.; Merritt, E. A. *Synlett* **2007**, 2459; (b) Bohlmann, F.; Rahtz, D. *Chem. Ber.* **1957**, *90*, 2265.
- ¹⁰¹ (a) Bagley, M. C.; Dale, J. W.; Ohnesorge, M.; Xiong, X.; Bower, J. J. *Comb. Chem.* **2003**, *5*, 41. (b) Bashford, K. E.; Burton, M. B.; Cameron, S.; Cooper, A. L.; Hogg, R. D.; Kane, P. D.; MacManus, D. A.; Matrunola, C. A.; Moody, C. J.; Robertson, A. A. B.; Warne, M. R. *Tetrahedron Lett.* **2003**, *44*, 1627.
- ¹⁰² Bagley, M. C.; Lunn, R.; Xiong, X. *Tetrahedron Lett.* **2002**, *43*, 8331.
- ¹⁰³ Xiong, X.; Bagley, M. C.; Chapaneri, K., *Tetrahedron Lett.* **2004**, *45*, 6121.
- ¹⁰⁴ Bagley, M. C.; Brace, C.; Dale, J. W.; Ohnesorge, M.; Phillips, N. G.; Xiong, X.; Bower, J. J. *Chem. Soc., Perkin Trans. 1* **2002**, 1663.
- ¹⁰⁵ Zhang, X.; Hayward, D. O.; Mingos, D. M. P. *Cat. Lett.* **2003**, *88*, 33.
- ¹⁰⁶ (a) Razzaq, T.; Glasnov, T. N.; Kappe, C. O. *Chem. Eng. Technol.* **2009**, *32*, 1702; (b) Glasnov, T. N.; Findenig, S.; Kappe, C. O. *Chem. Eur. J.* **2009**, *15*, 1001.
- ¹⁰⁷ (a) Loones, K. T. J.; Maes, B. U. W.; Rombouts, G.; Hostyn, S.; Diels, G., *Tetrahedron* **2005**, *61*, 10338; (b) Ferguson, J. D. *Mol. Diversity* **2003**, *7*, 281; (c) Bowman, M. D.; Schmink, J. R.; McGowan, C. M.; Kormos, C. M.; Leadbeater, N. E. *Org. Proc. Res. Dev.* **2008**, *12*, 1078; (d) Lehmann, H.; Lavecchia, L. *J. Assoc. Lab. Autom.* **2005**, *10*, 412; (e) Hoogenboom, R.; Paulus, R. M.; Pilotti, A.; Schubert, U. S. *Macromol. Rapid Commun.* **2006**, *27*, 1556.
- ¹⁰⁸ Moseley, J. D.; Woodman, E. K. *Org. Proc. Res. Dev.* **2008**, *12*, 967.
- ¹⁰⁹ Noriyuki, K.; Hitoshi, M.; Shionogi & Co. Ltd., Japan PCT Int. Appl. WO 03, 47, 564, **2002**; *Chem. Abstr.* **2003**, *139*, 36532c.
- ¹¹⁰ Jean-Damien, C.; David, B.; Ronald, K.; Julian, G.; Pan, Li; Robert, D.; Vertex Pharmaceuticals Incorporated, USA; PCT Int. Appl. WO 02 22, 608, **2002**; *Chem. Abstr.* **2002**, *136*, 247584x.
- ¹¹¹ Tokutake, N.; Brit. Pat.146836B, 1977; *Chem. Abstr.* **1977**, *87*, 102370.
- ¹¹² Kurono M.; JP, 62, 267, 272, 1987; *Chem. Abstr.* **1988**, *109*, 37382t.
- ¹¹³ (a) Adlington, R. M.; Baldwin, J. E.; Catterick, D.; Pritchard, G. J. *J. Chem. Soc., Perkin Trans. 1*, **1999**, 855; (b) Baldwin, J. E.; Pritchard, G. J.; Rathmell, R. E. *J. Chem. Soc., Perkin Trans. 1* **2001**, 2906.
- ¹¹⁴ Bagley, M. C.; Hughes, D. D.; Taylor, P. H. *Synlett* **2003**, 259.
- ¹¹⁵ Bagley, M. C.; Hughes, D. D.; Lubinu, M. C.; Merritt, E. A.; Taylor, P. H.; Tomkinson, N. C. O. *QSAR Comb. Sci.* **2004**, *23*, 859.
- ¹¹⁶ (a) Hantzsch, A. *Ber. Dtsch. Chem. Ges.* **1881**, *14*, 1637; (b) Hantzsch, A. *Justus Liebigs Ann. Chem.* **1882**, *215*, 1.
- ¹¹⁷ Vanden Eynde, J. J.; Mayence, A. *Molecules* **2003**, *8*, 381.
- ¹¹⁸ Flaim, S. F.; Zelis, R. *Fed. Proc.* **1981**, *40*, 2877.
- ¹¹⁹ Triggle, D. J.; Janis, R. A. *Modern Methods in Pharmacology*; Liss: New York, 1984; Vol. II, p 1.
- ¹²⁰ Öhberg, L.; Westman, J. *Synlett* **2001**, 1296.
- ¹²¹ Watanabe, Y.; Shiota, K.; Hoshiko, T.; Ozaki, S. *Synthesis* **1983**, 761.
- ¹²² Kormos, C. M.; Hull, R. M.; Leadbeater, N. E. *Aust. J. Chem.* **2009**, *62*, 51.
- ¹²³ Gompel, M. L.; Leost, M.; Joffe, E. B. D. K.; Puricelli, L.; Franco, L. H.; Palermo, J.; Meijer, L. *Bioorg. Med. Chem. Lett.* **2004**, *14*, 1703.

- ¹²⁴ Karpov, A. S.; Merkul, E.; Rominger, F.; Muller, T. J. *J. Angew. Chem. Int. Ed.* **2005**, *44*, 6951.
- ¹²⁵ (a) Kaiser, N. F. K.; Hallberg, A.; Larhed, M. *J. Comb. Chem.* **2002**, *4*, 109; (b) Georgsson, J.; Hallberg, A.; Larhed, M. *J. Comb. Chem.* **2003**, *5*, 350; (c) Wannberg, J.; Larhed, M. *J. Org. Chem.* **2003**, *68*, 5750.
- ¹²⁶ Fox, M. A.; Cameron, A. M.; Low, P. J.; Paterson, M. A. J.; Batsanov, A. S.; Goeta, A. E.; Rankin, D. W. H.; Robertson, H. E.; Schirlin, J. T. *J. Chem. Soc., Dalton Trans.* **2006**, 3544.
- ¹²⁷ Lindley, J. *Tetrahedron* **1984**, *40*, 1433.
- ¹²⁸ (a) Ullmann, F. *Chem. Ber.* **1903**, *36*, 2382; (b) Ullmann, F.; Sponagel, P. *Chem. Ber.* **1905**, *36*, 2211; (c) Goldberg, I. *Chem. Ber.* **1906**, *39*, 1691; (d) Kunz, K.; Scholz, U.; Ganzer, D. *Synlett* **2003**, 2428; (e) Ullmann, F. *Chem. Ber.* **1901**, *34*, 2174.
- ¹²⁹ Van Allen, D. *Methodology and mechanism: reinvestigating the Ullmann reaction*. PhD thesis, University of Massachusetts Amherst, 2004.
- ¹³⁰ Komiya, S.; Albright, T. A.; Hoffmann, R.; Kochi, J. K. *J. Am. Chem. Soc.* **1976**, *98*, 7255.
- ¹³¹ Varala, R.; Ramu, E.; Alam, M. M.; Adapa, S. R. *Chem. Lett.* **2004**, *33*, 1614.
- ¹³² Migita, T.; Shimizu, T.; Asami, Y.; Shiobara, J.; Kato, Y.; Kosugi, M. *Bull. Chem. Soc. Jpn.* **1980**, *53*, 1385.
- ¹³³ (a) Schopfer, U.; Schlapbach, A. *Tetrahedron* **2001**, *57*, 3069; (b) Mispelaere-canivet, C.; Splinder, J. F.; Perrio, S.; Beslin, P. *Tetrahedron* **2005**, *61*, 5253.
- ¹³⁴ Wu, Y. J.; He, H., *Synlett* **2003**, 1789.
- ¹³⁵ Wu, Y. J.; He, H. *Tetrahedron* **2003**, *59*, 3445.
- ¹³⁶ (a) Kantchev, E. A.; O'Brien, C. J.; Organ, M. G. *Angew. Chem. Int. Ed.* **2007**, *46*, 2768; (b) O'Brien, C. J.; Kantchev, E. A.; Valente, C.; Hadei, N.; Chass, G. A.; Lough, A.; Hopkinson, A. C.; Organ, M. G. *Chem. Eur. J.* **2006**, *12*, 4743; (c) Organ, M. G.; Avola, S.; Dubovyk, I.; Hadei, N.; Kantchev, E. A.; O'Brien, C. J.; Valente, C. *Chem. Eur. J.* **2006**, *12*, 4749.
- ¹³⁷ (a) Álvarez, R.; Perez, M.; Nieto Faza, O.; de Lera, A. R. *Organometallics* **2008**, *27*, 3378; (b) Espinet, P.; Echavarren, A. M. *Angew. Chem. Int. Ed.* **2004**, *43*, 4704.
- ¹³⁸ Bates, C. G.; Gujadhur, R. K.; Venkataraman, D. *Org. Lett.* **2002**, *4*, 2803.
- ¹³⁹ Gujadhur, R. K.; Bates, C. G.; Venkataraman, D. *Org. Lett.* **2001**, *3*, 4315.
- ¹⁴⁰ (a) Roberts, B. A.; Strauss, C. R. *Acc. Chem. Res.* **2005**, *38*, 653; (b) Bagley, M. C.; Lubinu, C. M.; Mason, C. *Synlett* **2007**, 704.
- ¹⁴¹ Kwong, F. Y.; Buchwald, S. L. *Org. Lett.* **2002**, *4*, 3517.
- ¹⁴² Carril, M.; SanMartin, R.; Dominguez, E.; Tellitu, I. *Chem. Eur. J.* **2007**, *13*, 5100.
- ¹⁴³ (a) Schieven, G. L. *Curr. Top. Med. Chem.* **2005**, *5*, 921; (b) Cuenda, A.; Rousseau, S. *Biochim. Biophys. Acta* **2007**, *1773*, 1358; (c) Lee, J. C.; Laydon, J. T.; McDonnell, P. C.; Gallagher, T. F.; Kumar, S.; Green, D.; McNulty, D.; Blumenthal, M. J.; Heyes, J. R.; Landvatter, S. W. *Nature* **1994**, *372*, 739.
- ¹⁴⁴ Dominguez, C.; Tamayo, N.; Zhang, D. *Expert Opin. Ther. Patents* **2005**, *15*, 801.
- ¹⁴⁵ Williams, R.; Barker, H. *InnovAiT* **2010**, *12*, 743.
- ¹⁴⁶ Raffan, E.; Hurst, L. A.; Al Turki, S.; Carpenter, G.; Scott, C.; Daly, A.; Coffey, A.; Bhaskar, S.; Howard, E.; Khan, N.; Kingston, H.; Palotie, A.; Savage, D. B.; O'Driscoll, M.; Smith, C.; O'Rahilly, S.; Barroso, I. Semple, R. K. *Front. Endocrinol.* **2011**, DOI: 10.3389/fendo.2011.00008.
- ¹⁴⁷ (a) Bemis, G. W.; Salituro, F. G.; Duffy, J. P.; Cochran, J. E.; Harrington, E. M.; Murcko, M. A.; Wilson, K. P.; Su, M.; Galullo, V.P. WO 98/27098 1998; (b) Bemis, G. W.; Salituro, F. G.; Duffy, J. P.; Cochran, J. E.; Harrington, E. M.; Murcko, M. A.; Wilson, K. P.; Su, M.; Galullo, V. P. *Chem. Abstr.* **1998**, *129*, 81749; (c) Bemis, G. W.; Salituro, F. G.; Duffy, J. P.; Harrington, E. M. U.S. Patent 6, 147,080 2000; (d) Bemis, G. W.; Salituro, F. G.; Duffy, J. P.; Harrington, E. M. *Chem. Abstr.* **2000**, *133*, 350242; (e) Natarajan, S. R.; Doherty, J. B. *Cur. Top. Med. Chem.* **2005**, *5*, 987; (f) Lee, M. R.; Dominguez, C. *Curr. Med. Chem.* **2005**, *12*, 2979; (g) Haddad, J. *Curr. Opin. Invest Drugs* **2001**, *2*, 1070.
- ¹⁴⁸ Treu, M.; Jordis, U.; Lee, V. J. *Molecules* **2001**, *6*, 959.
- ¹⁴⁹ (a) Bagley, M. C.; Davis, T.; Dix, M. C.; Rokicki, M. J.; Kipling, D. *Bioorg. Med. Chem. Lett.* **2007**, *17*, 5107; (b) Bagley, M. C.; Davis, T.; Dix, M. C.; Fusillo, V.; Pigeaux, M.; Rokicki, M. J.; Kipling, D. *J. Org. Chem.* **2009**, *74*, 8336.
- ¹⁵⁰ Natarajan, S. R.; Wisnoski, D. D.; Singh, S. B.; Stelmach, J. E.; O'Neill, E. A.; Schwartz, C. D.; Thompson, C. M.; Fitzgerald, C. E.; O'Keefe, S. J.; Kumar, S.; Hop, C. E. C. A.; Zaller, D. M.; Schmatz, D. M.; Doherty, J. B. *Bioorg. Med. Chem. Lett.* **2003**, *13*, 273.
- ¹⁵¹ (a) Coad, P.; Coad, R. A.; Hyepock, J. *J. Org. Chem.* **1964**, *29*, 1751; (b) Draper, T. L.; Bailey, T. R. *J. Org. Chem.* **1995**, *60*, 748.
- ¹⁵² <http://www.fda.gov/ForConsumers/ByAudience/ForPatientAdvocates/HIVandAIDSActivities/ucm118915.htm>
- ¹⁵³ Clavel F.; Hance A. J. *N. Engl. J. Med.* **2004**, *350*, 1023.
- ¹⁵⁴ Balzarini, J.; Stevens, M.; DeClercq, E.; Schols, D.; Pannecouque, C. *J. Antimicrob. Chemother.* **2005**, *55*, 135; Stevens, M.; Pannecouque, C.; DeClercq, E.; Balzarini, J. *Antimicro. Agents Chemother.* **2003**, 2951;

- Balzarini, J.; Stevens, M.; Andrei, G.; Snoeck, R.; Strunk, R.; Pierce, J. B.; Lacadie, J. A.; DeClercq, E.; Pannecouque, C. *Helv. Chim. Acta* **2002**, *85*, 2961.
- ¹⁵⁵ Ranu, B. C.; Saha, A.; Jana, R. *Adv. Synth. Catal.* **2007**, *349*, 2690.
- ¹⁵⁶ Mosher, H. S.; Turner, L.; Carlsmith, A. *Org. Synth.* **1963**, *4*, 828.
- ¹⁵⁷ Varma, R.; Naicker, K. P. *Org. Lett.* **1999**, *1*, 189.
- ¹⁵⁸ Biomedical Frontiers of Fluorine Chemistry (Eds.: I. Ojima, J. R. McCarthy, J. R. Welch), ACS Symposium Series 639, American Chemical Society, Washington, DC, 1996.
- ¹⁵⁹ Balz, G.; Schiemann, G. *Chem. Ber.* **1927**, *60*, 1186.
- ¹⁶⁰ (a) Taylor, E.C.; Bigham, E.C.; Johnson, D.K.; McKillop, A. *J. Org. Chem.* **1977**, *42*, 362; (b) Grushin, V. V.; Kantor, M. M. Tolstaya, T. P. Shcherbina, T. M. *Izv. Akad. Nauk SSSR Ser. Khim.* **1984**, 2332.
- ¹⁶¹ Finger, G. C.; Kruse, C. W. **1956**, 6034; Langlois, B.; Gilbert, L.; Forat, G. *Ind. Chem. Libr.* **1996**, *8*, 244.
- ¹⁶² (a) Shimizu, M.; Hiyama, T. *Angew. Chem. Int. Ed.* **2005**, *44*, 214; (b) Brown, J. M.; Gouverneur, V. *Angew. Chem. Int. Ed.* **2009**, *48*, 8610; (c) Grushin, V. V. *Chem. Eur. J.* **2002**, *8*, 1006; (d) Gouverneur, V. *Science* **2009**, *325*, 1630; (e) Watson, D. A.; Su, M.; Teverovskiy, G.; Zhang, Y.; Garcia-Fortanet, J.; Kinzel, T.; Buchwald, L. *Science* **2009**, *325*, 1661.
- ¹⁶³ Grushin, V.V. U.S. Patent 7,202,388 B2, 2007.
- ¹⁶⁴ (a) Furuya, T.; Strom, A. E.; Ritter, E. *J. Am. Chem. Soc.* **2009**, *131*, 1662; (b) Tang, P.; Furuya, T.; Ritter, T. *J. Am. Chem. Soc.* **2010**, *132*, 12150.
- ¹⁶⁵ (a) Watson, D. A.; Su, M.; Teverovskiy, G.; Zhang, Y.; Garcia-Fontanet, J.; Kinzel, T.; Buchwald, S. L. *Science* **2009**, *325*, 1661; (b) Fors, B. P.; Watson, D. A.; Biscoe, M. R.; Buchwald, S. L. *J. Am. Chem. Soc.* **2008**, *130*, 13552.
- ¹⁶⁶ (a) Noël, T.; Naber, J. R.; Hartman, R. L.; McMullen, J. P.; Jensen, K. F.; Buchwald, S. L. *Chem. Sci.* **2011**, *2*, 287; (b) Naber, J. R. *Advances in the Stille reaction and new methods for continuous flow Pd-catalyzed C-N bond forming reactions*. PhD Thesis, Massachusetts Institute of Technology, 2010.
- ¹⁶⁷ Fetter, J.; Nagy, I.; Giang, L. T.; Kajtár-Peredy, M.; Rockenbauer, A.; Korecz, L.; Czira, G. *J. Chem. Soc., Perkin Trans. I.* **2001**, 1331.
- ¹⁶⁸ Bagley, M. C.; Brace, C.; Dale, J. W.; Ohnesorge, M.; Phillips, N. G.; Xiong, X.; Bower, J. J. *J. Chem. Soc., Perkin Trans. I* **2002**, 1663.
- ¹⁶⁹ Wagner, M.; Jutz, C. *Chem. Ber.* **1991**, *104*, 2975.
- ¹⁷⁰ Schenone, P.; Sansebastiano, L.; Mosti, L. *J. Heterocyclic Chem.* **1990**, *27*, 295.
- ¹⁷¹ Schiff, R.; Puliti, J. *Ber. Dtsch. Chem. Ges.* **1883**, *16*, 1607.
- ¹⁷² Engelman, F. *Justus Liebigs Ann. Chem.* **1885**, *231*, 37.
- ¹⁷³ Kornblum, N. *J. Org. Chem.* **1976**, *41*, 1560.
- ¹⁷⁴ *The Merck Index: An Encyclopedia of Chemicals, Drugs, and Biologicals*, 14th ed.; O'Neal, M. J.; Whitehouse Station, New Jersey, 2006; entry 7314.
- ¹⁷⁵ Cano, R.; Ramon, D. J.; Yus, M. *J. Org. Chem.* **2011**, *76*, 6819.
- ¹⁷⁶ Itoh, T.; Mase, T. *Org. Lett.* **2004**, *6*, 4587.
- ¹⁷⁷ Appel, R. *Chem. Ber.* **1962**, *95*, 2220.
- ¹⁷⁸ Furukawa, M. *Synthesis* **1975**, 165.