

POLE DE RECHERCHE OCEANOLOGIQUE ET HALIEUTIQUE CARAIBE

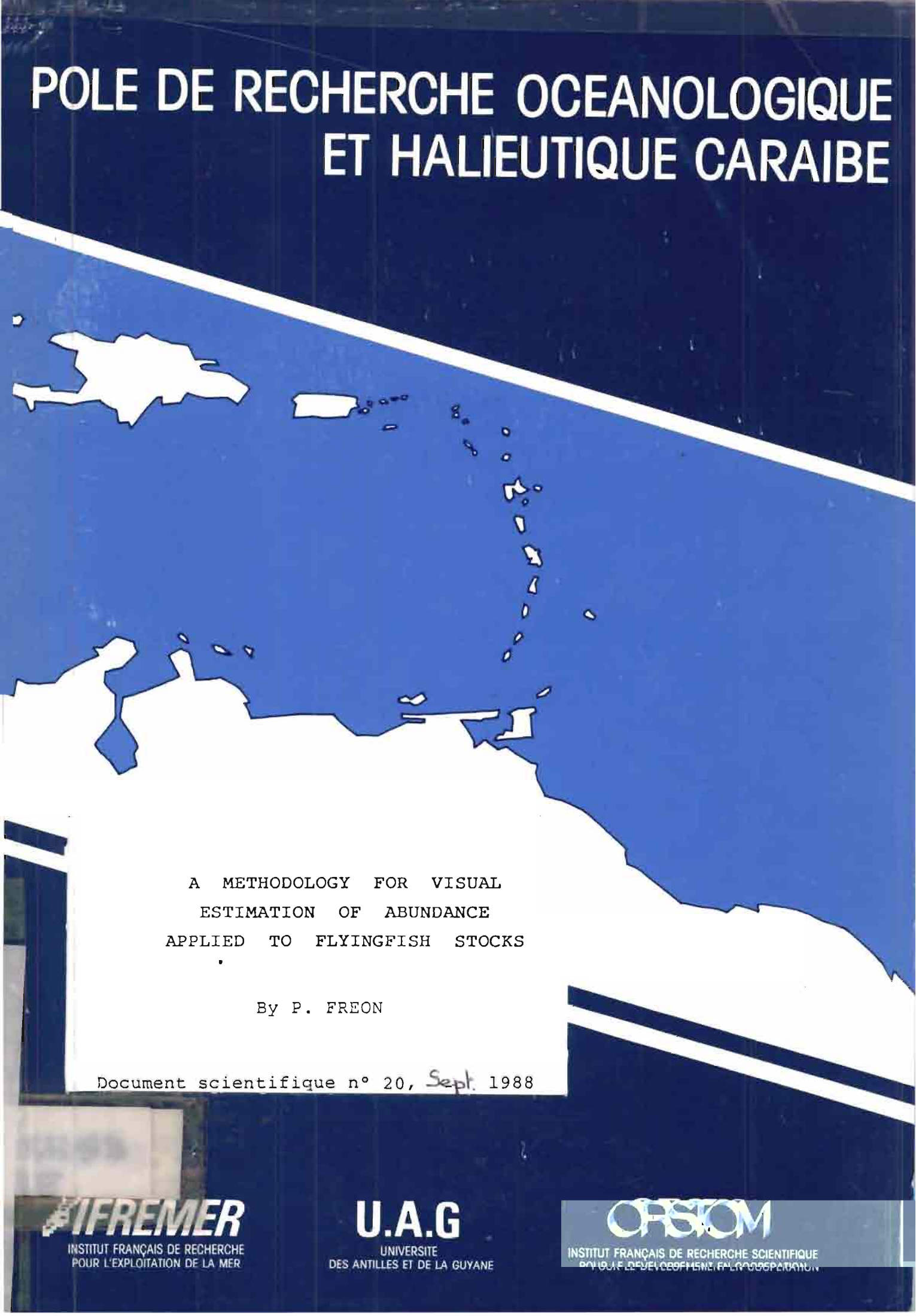

A METHODOLOGY FOR VISUAL
ESTIMATION OF ABUNDANCE
APPLIED TO FLYINGFISH STOCKS

By P. FREON

Document scientifique n° 20, *Sept.* 1988

IFREMER

INSTITUT FRANÇAIS DE RECHERCHE
POUR L'EXPLOITATION DE LA MER

U.A.G

UNIVERSITE
DES ANTILLES ET DE LA GUYANE

OPSTOM

INSTITUT FRANÇAIS DE RECHERCHE SCIENTIFIQUE
POUR LE DEVELOPPEMENT EN COOPERATION

A METHODOLOGY FOR VISUAL
ESTIMATION OF ABUNDANCE
APPLIED TO FLYINGFISH STOCKS

By P. FREON

Document scientifique n° 20, *Sept.* 1988

A METHODOLOGY FOR VISUAL
ESTIMATION OF ABUNDANCE
APPLIED TO FLYINGFISH STOCKS

By : P. Fréon

Pôle Caraïbe, ORSTOM BP 81, 97256 Fort de France, Martinique

RESUME

Une méthode d'estimation de l'abondance des stocks de poissons volants est proposée. Elle est basée sur des comptages, regroupés par intervalles de distance réguliers, de poissons s'envolant à l'approche d'un bateau de recherche effectuant des radiales prédéterminées. En cela la méthode s'apparente aux évaluations de stock par écho-intégration.

Durant les campagnes, on collectera diverses variables (biologiques, physiques et climatiques) pouvant influencer directement ou indirectement les estimations d'abondance ou la répartition de la ressource. La méthodologie d'observation (directe et avec caméra) et d'analyse des données est décrite, ainsi que l'équipement nécessaire afin de saisir directement sur support informatique un maximum de données.

ABSTRACT

A methodology for flyingfish abundance estimation is proposed. It is based on counting of fishes, when forced into flight by a research vessel following predetermined transects, regrouped on regular distance units. In this way, the method is somehow related to acoustic survey methodology.

Different variables (biological, physical and environmental ones), that may influence directly or undirectly the abundance estimation or the stock distribution, have to be collected during the survey. The methodology of observation (direct or using a camera) and of data processing is described, as well the equipment required to store most of the data directly in a computer unit.

RESUMEN

Se propone un método de evaluación de la abundancia de los stocks de peces voladores. Este método se basa sobre conteos, agrupados por intervalos de distancia regulares, de peces volando cuando se acerca un barco de investigaciones siguiendo transectos predefinidos. En éste sentido, el método se relaciona con las estimaciones de la abundancia por eco-integración.

Durante las campañas, se recolectan varias variables (biológicas, físicas y ambientales) que pueden tener una influencia, directa o indirecta, sobre las evaluaciones de la abundancia o sobre la distribución del recurso. Se presenta la metodología de observación (directa o con cámara) y de análisis de los datos, así como el equipo necesario para llevar a cabo una computalización directa de un número máximo de datos.

INTRODUCTION

Flyingfish are a major source of protein, employment and revenue throughout the eastern Caribbean, often ranking first or second in importance by weight of all species landed in most countries of the area. Approximately 4.000 metric tons per year are landed in the different islands. The need for fisheries management and thus for stock assessment is evident for this species (Mahon et al, 1986).

The lack of reliable effort and age structure data and the heterogeneous nature of the fishery prevent the use of conventional methods of population dynamics. Flyingfish are a wide-ranging pelagic species, thus their spacial distribution and stock composition are poorly known. A broad research survey is necessary now in order to obtain these and the other basic population data. Since fishing alone does not provide the most accurate biomass estimates for pelagic species, the use of hydroacoustic methods for biomass estimation is being tested in Martinique.

An echo-survey trial using a downward facing fixed transducer on a laterally towed body was made (Gerlotto and Oxenford, pers. com.) in order to determine whether flyingfish remain deep enough below the surface to be detected. Results show that because these fish swim very close to the surface, this method was not appropriate. Additional echo-survey investigations should be made with a deep laterally towed body, similar to those used for pelagic fish (Diner and Massé, 1987), but looking upwards. However, even when not disturbed, the flyingfish remain so close to the surface that they will be indistinguishable from the surface echo except under ideal weather conditions rarely observed offshore. Thus a visual survey method is proposed here that is very similar to the echo-survey approach but avoids this acoustical problem.

Flyingfish are observed to jump out of the water when a (research) vessel approaches and we can therefore take advantage of this behaviour to observe the fish directly rather than using sophisticated devices (sonar, underwater camera, etc.) which rarely enable counting and species identification. Former researchers have made use of this behaviour as it can be seen in the bibliography compiled by Fabres (1986) (Breder, 1929; Hubbs, 1933, 1937). More recently, some quantitative estimations have been done onboard Soviet ships during long trips across the oceans, but little is known about the methodology used (Shuntov, 1973; Zuyev and Nikol'skiy, 1980; Nesterov and Grudtsev, 1981).

The following paper describes the variables to be collected in a visual survey and details the proposed methodology, equipment required and data processing. In the final section, further methodological requirements are considered.

VARIABLES OBTAINABLE DURING A VISUAL SURVEY

Biological variables

Fish density (expressed in number of fish) can be reasonably estimated using a hypothesis based on the proportion of fish forced into flight by the boat, and on the water surface area involved in this fright behaviour. A relative index of density can at least be estimated using the same methodology from one survey to the next. Then the biomass (or at least an index of abundance) can be calculated from the fish density.

Species composition is generally easy to obtain from a trained observer who is able to identify the different species according to their pectoral fin (wing) colour, type of flight and maximum size (Oxenford, pers. com.).

Size structure can be roughly obtained by direct observation or by video play-back and picture calibration when only three or four age/size groups allow a good enough description of the population demographic structure. The fast growth of these species and their short longevity (Mahon *et al.*, 1986) probably allow the use of structural models with such rough data.

Physical and chemical variables

The following variables may be important for understanding flyingfish distribution or the flying behaviour and therefore may be relevant for the calibration of the method. It is difficult at this stage of our knowledge to classify these variables in order of priority. Nevertheless we present in brackets the variables which we feel are less important than the others.

Position of the boat geographically must be recorded periodically during the survey in order to allow mapping of the resource.

Boat speed is also needed as it probably influences the distance of take-off of the flyingfish and the proportion of fish school flying.

(Engine revolutions per minute) should be collected because the noise (frequency and intensity) may be an important source of stress. This variable is closely related to the previous one if the same boat is used for each survey.

Boat course during each transect can be useful to compare with the sun position in order to test any behavioural change according to the light direction.

(Boat drift) can provide information on the current strength and direction when the wind does not strongly influence the boat drift.

Wind velocity and direction influence the direction of the fish flights and their range (Breder, 1929; Hubbs, 1937).

Swell direction may have a similar effect.

Swell height may also influence the flight range and the conditions of observation.

(General meteorological data) such as the air temperature, humidity, atmospheric pressure, etc. are unlikely to be determinant variables in a tropical area since, for example, air temperature is fairly constant and correlated with water temperature. However, these variables are easily available from the usual meteorological station on board and may be of some value.

The color of the sea could be an important variable affecting flyingfish distribution and abundance. We can classify at least three major types of water by quality, namely : oligotrophic blue water offshore, richer green water with phytoplankton, and turbid brown water.

Water transparency can also provide an index of water quality associated with the color.

Water temperature, even if relatively stable in the tropical area, may provide an interesting description of the water mass, especially in the upwelling areas.

Water salinity is probably not a determinant variable in itself (except for the low values observed in the coastal area), but is often a good indicator of the water-mass.

Hour of observation is probably an important parameter because it may influence the fish behaviour and the quality of the visual observations according to boat course, as mentioned previously.

The weather may also change the fish behaviour and the quality of the observations (rain, dust, clouds, etc).

The moon phase and position must be recorded if the survey is also done during the night (see later).

The presence of floating debris or FADs must also be recorded because they can aggregate the fish, especially during the spawning season.

METHODOLOGY OF THE SURVEY

The survey design

The survey design will depend mainly on three factors : the stock characteristics (density distribution, patchiness, migration, ...), the objective of the survey and the means available (time, boat(s), crew, equipment, ...).

A minimum knowledge of the stock's likely distribution is required before designing the survey. If such information is not at hand, a series of preliminary pilot surveys covering an exten-

sive area during different seasons would be necessary.

Different objectives may be assigned to a survey, but the more common are the following ones :

(1) to assess the spatial distribution of the stock at any one moment (instantaneous picture),

(2) to study the fish migrations by repeating the previous survey in different seasons,

(3) to estimate the total biomass of the stock,

(4) to study the relative fluctuations of the biomass from one survey to the next,

(5) to estimate the biomass of one component of the stock e.g. the spawning stock or the recruitment (0-group age class).

The level of biomass knowledge required depends on the survey objectives : objectives (3) and (5) involve an estimation of the absolute biomass, meanwhile the other objectives require only an index of abundance.

As for acoustic survey design, the area to be visually surveyed must be covered by pre-established transects. Special attention must be given to the initial choice of the distance between transects, their position and their orientation with respect to the randomization requirement. Of equal importance is the sequence length of cumulative observations, also named elementary sampling distance unit (ESDU), expressed in distance or in time. These factors may seriously limit the final biomass estimation if they are not properly established (Johannesson and Mitson, 1983; Jolly and Hampton, 1987).

In the case of flyingfish, the position of the transects with respect to the depth is probably not essential around the Caribbean islands (for the continental shelf edge it may be different). More attention should be paid to the hydrological structure (upwellings, currents, frontal structures). Our knowledge of the Caribbean hydrology and of the flyingfish preferendum may not be good enough at the moment to give any reliable suggestions for special survey designs, although the ideas presented by Mahon (1986) considerably advanced the subject. As for any large pelagic stock distributed in open water, both random sampling or proportional allocation or any a priori stratification of effort sampling technique seem unrealistic.

The choice between parallel transects or oblique ones (zigzag transects) has been widely discussed for acoustical survey (Johannesson and Mitson, 1983; Laloé, 1985; Jolly and Hampton, 1987) with reference to factors such as : boat time, boat speed, area covered and transect spacing. Formulae allowing estimations of the total length of the survey according to these factors have been proposed by these authors and can be used for comparing the two patterns of survey. This choice does not seem fundamental here because the survey covers a very large area in two dimensions (at least for the initial pilot surveys) and be-

cause we have no indication of the existence of any geographic gradient in the biomass distribution. Therefore the transects must be very long, and parallel transects will not need significantly more time than zigzag transects but will give a more homogeneous sampling of the area. The usual systematic survey grid pattern with a non-randomly selected starting point would be a valid approach because the fish themselves, by their mobility, would take care of the randomization requirement of the transect position, as noted by Johannesson and Mitson (1983).

The essential question then is the distance between transects. The choice must be made according to the type of distribution of the fish (Fiedler, 1978; Barbieri Bellolio, 1981). Since the fish are non-randomly distributed and probably have two levels of aggregation (concentration and "schools") the problem is not easy to solve. The better approach is probably to start with a relatively short distance between transects in a limited area and to make statistical simulations from these first results (Gerlotto and Stequert, 1982). If the boat time is limited, these authors recommended starting with a wide equidistant inter-transect spacing during the first part of the survey, and then returning to the richest areas for more dense sampling. The consequences of this approach for data processing will be seen later.

In tropical areas the useful daytime period for visual observation is relatively short (around 10 hours) and constant. As surveys are time consuming it is useful to extend the daily period of observation into the night using artificial lights (or highly sensitive equipment, but this latter solution is very expensive and inconvenient). Of course the results would not be directly comparable to those obtained during the daytime, as for acoustic surveys, because the fish behaviour would be different. Nevertheless the two kinds of observations could be intercalibrated more easily than in the case of an acoustic survey. If not, this would mean that they give very different and probably complementary results, and in such a case the survey design could be established for covering each transect by day and by night.

Each ESDU should cover around 2 nautical miles owing to the large distribution of the stock. It must be remembered that the statistical efficiency of the ESDU is also closely related to the temporal and spacial characteristics of the stock distribution. Its length must be short enough for studying the type of distribution of the resource, but long enough to limit the autocorrelation in the ESDU series (Gerlotto and Stequert, 1983). Moreover, when using short sequences the proportion of sequences without fish detections will increase and therefore the play-back of the video recording can be done faster if those null sequences are registered during the survey.

It is generally easier to use a time unit for resetting the abundance measurement instead of a distance unit during the survey, considering that the boat speed is relatively constant. According to the boat speed, the length of the sequence should be between 5 and 10 minutes.

If possible the surveys should be done at the same speed. The optimal speed must be determined, but it can be assumed that

high speeds allow a good stimulus for flying without disturbing the recording. The main factors for optimizing the speed are probably the daily costs of the boat (type of boat and fuel consumption) compared to the daily costs of the crew (scientists and sailors). Trials using chartered sport-fishing boats could be made.

The fishing operation

Biological samples may be desired for validating the species identification and calibrating the size estimation, or for biological studies. In such a case, as for acoustic surveys, one must choose between the ideal solution of using two different boats for the survey and for the sampling, and the cheapest solution of using a single boat. In the case of flyingfish this question is primordial because fishing operations using first attraction methods and then passive or active gears are generally longer than the trawling operations used for other species. The problem can be partially overcome if the survey is made only during the day and night is spent fishing in the area of concentration observed during the day. But this solution is not optimal because it may be difficult to refind the concentration and because one is never sure of catching the same fish observed several hours before. If only one boat is available, a good solution is to limit the fishing station to the place where the fish identification is doubtful (several species and size for example). As the transects are generally long, in most of the cases the time spent between an observation of fish concentration and the next passage of the boat near this point on the following transect will be long enough (fig. 1). This allows the set of a gill-net that could be recovered a few hours later with a minimum waste of time.

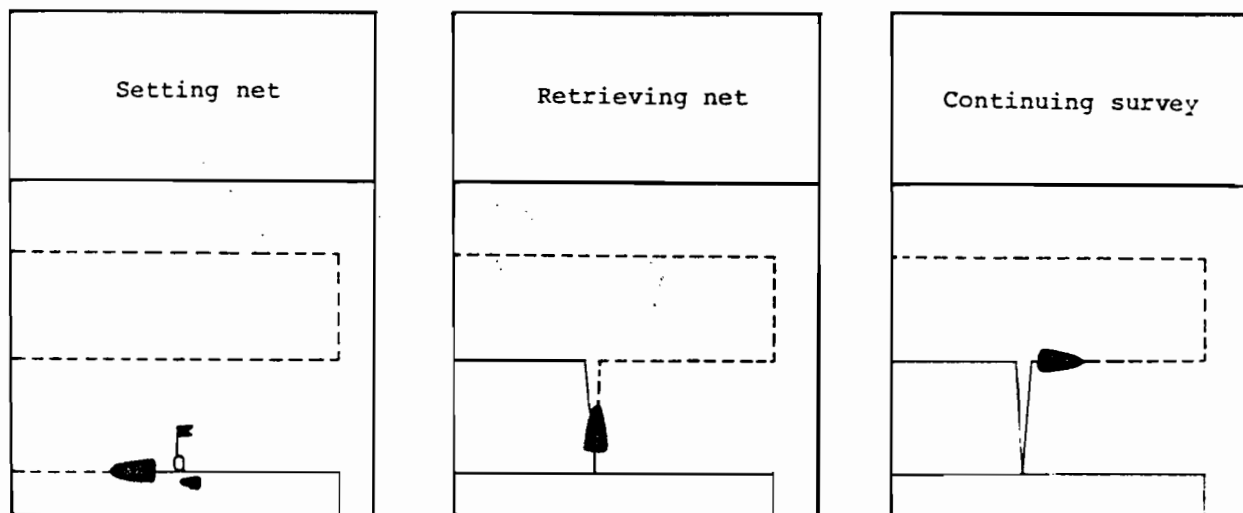

Fig. 1 - Example of a survey track design to minimise time when lengthly fishing operations are being conducted.

Visual sampling at sea

The principle of the method is known (Breder, 1929) : the average fish density along the transect must be estimated for each visual sequence, and then the biomass of the area surveyed can be obtained by multiplying the fish densities by the corresponding surfaces along the transect in order to cover the whole area. The allocation of surface for each sequence can be done using different graphical methods described below.

Both direct visual observation by an observer placed on the roof of the boat and recording observations using a video-camera and a video-tape recorder allowing playback in the laboratory should be used.

Two different levels of knowledge of the abundance may be required by the survey, according to the objective(s), either :

- (1) : estimation of a relative index of abundance, or
- (2) : estimation of the absolute biomass.

The methodology will be different according to the requirement of the survey. If only a relative index of abundance is needed, it will be important to conduct each survey under the same conditions, with the same equipment and, as far as possible, with the same observers, and to hope that there will be no predominant influence by uncontrollable external factors from one survey to the next. In the case of absolute biomass estimation, additional conditions are required in order to estimate the real density and then to extrapolate to the whole population. In each case, two methodological approaches can be used :

(1) a total count of the number of fish flying when the boat is passing would be sufficient to determine relative indices of abundance, assuming one can find a practical method for counting. To obtain an estimate of actual abundance, two further criteria would have to be met;

(a) the "flying area" relative to the area of the school (or concentration) would need to be determined. This is not easy to determine using only the observed distance of flight from the boat, because the fish may swim a long distance below the surface before flying, as suggested by Breder (1929);

(b) the proportion of fish school which flies in this area will have to be determined. From surface observations, Zuyev and Nikol'skiy (1980) estimated the vertical distribution of flyingfish (mainly Exocoetus volitans in the eastern tropical Atlantic) and their avoidance behaviour when a boat is passing. These authors estimated that an average of 40 % of the fish emerge from the whole depth occupied by the flyingfish (0 to 5 metres) with a higher probability of emergence of the fish located in the upper zone;

(2) the "flying area" should be subsampled in order to redu-

ce the errors or bias due to the physical limitations of the eye when counting at sea or on a video screen. The optimal size of the subsample and where on the boat to sample from (laterally or over the bow) would have to be determined.

The optimal sample area may be very small in the case of high abundance (schools) without significant losses in the precision of the estimates. However, in the case of low abundance (scattered fish), a small sample area may lead to poor precision. In order to overcome this problem, when reading video records made with a wide angle lens, a temporal or spacial subsample can be imposed systematically or randomly on the screen (see last section). A better solution would be to use two cameras with two different focal lengths: the largest would be used for subsampling the other, with the advantage of allowing easier fish tracking. However the problem of the position of this subsample must be solved.

As the distribution of fish take-offs and flights is not random around the boat but is at least dependent on the wind direction (Breder, 1929) and on the distance from the boat (Zuyev and Nikol'skiy, 1980), the position of the sample (or of the subsample) is important. Breder (1929) observed that flyingfish along the south-east coast of the U.S. flew into the wind in the ratio of 1 to 3. This author sampled alternatively on starboard and on port during periods of one-half hour. This methodology can be applied to shorter periods as the 5 to 10 mn ESDU previously defined. If the main objective is to obtain a relative abundance index, the assumption that the **gradient** of the number of fish flying along one side of the boat is independent of external factors that cannot be held constant during the survey (such as swell, wind, light intensity and direction, etc.) must be verified before choosing the sample area. The influence of these factors on the flight distribution must be studied carefully, especially if the sampled area covers less than half of the potential "flying area". If the influence of those uncontrollable external factors is large, then the sampling approach would be unsuitable before quantifying these effects, which may mean many years of research.

If an estimate of actual abundance is required, the ratio of fish inside and outside the sampled area must be statistically estimated under different conditions (controlled and uncontrolled) in order to make a proper statistical inference to the total "flying area" and to the whole area under survey.

In any case of sampling, the observations and the views recorded must be obtained from the same place and must cover the same area on the sea surface with reference to the boat. The observer could use a solid frame made with four boards as a viewfinder, previously adjusted to give the same field of view as the camera. The main difficulty would be to stabilize the camera movements, especially on a small boat and under bad weather conditions. Operating the camera manually for long time periods would be difficult and may introduce an overestimation of the biomass because of the natural tendency to orient the camera towards the higher fish density.

Data recording

The observer will use a microphone connected to both a video recorder and a loud-speaker through an amplifier in order to communicate with a second scientist inside the boat (fig. 2). The second person will record on a log-sheet for each time interval the cumulative observations and the main physical data (fig. 3). A second log-sheet must be used by the crew for the other variables. Even if all the biological and physical data are automatically recorded by the video recorder and by a computer, this manual recording is a useful precaution in case of technical problems. Moreover such manual recording at sea saves time later in the laboratory, as previously mentioned.

The information given by the observer must be encoded, brief and clear. The conventionally used name of the species must be short. The number of size categories must not exceed four in order to avoid subjective interpretation. The abundance should be classified in three categories :

- individual fish,
- scattered fish (or schools)
- schools.

For individual fish, the "lab-scientist" can record all the observations during a sequence. Scattered fish or schools could be characterized by the cumulated time of appearance using a chronometer, if an additional scientist was available on board. If not, the abundance estimation would be done at the marine station, using the video recording.

All the other variables mentioned above can be obtained and recorded automatically, without stopping the boat, using modern recording instruments interfaced with a desktop computer (see below). The only measurements difficult to handle without stopping the boat are the colour of the sea and the water transparency. As high precision is not needed for these two variables, a simple colour chart could be used for the first one, with around 8 colors (2 blue, 1 green-blue, 2 green, 1 green-brown, and 2 brown for example). A rough index of water transparency could be obtained by using a meter white vertical tube fixed to the boat, and/or a white towed body behind the boat and controlled with a measuring pulley and a winch. Both devices must be installed near the stern in order to avoid a dissymmetrical effect on the fish flight.

If night surveys are conducted, powerful floodlights would have to be installed at the bow. Around dawn and dusk it will probably be impossible to make good observations, not only because of poor visibility but also because fish behaviour is changing and unstable at this time. These periods could be used for fishing.

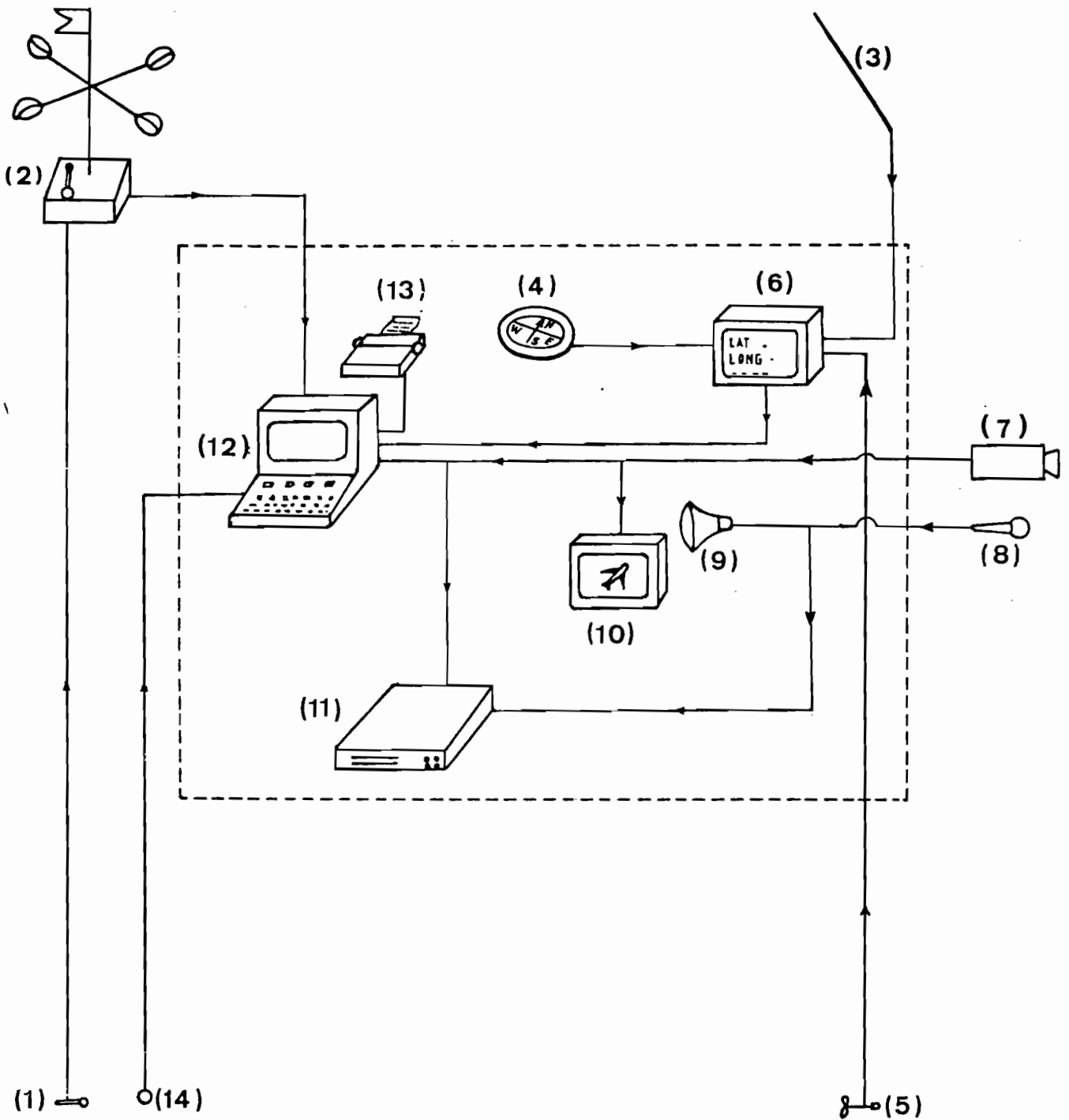

Fig. 2 - Equipment for visual survey.

- | | |
|----------------------------------|--------------------------|
| (1) Sea-water temperature sensor | (8) Microphone |
| (2) Meteorological station | (9) Loud-speaker |
| (3) Satellite antenna | (10) Video screen |
| (4) Compass | (11) Video tape recorder |
| (5) Speedometer (log) | (12) Desktop computer |
| (6) Satellite navigator | (13) Printer |
| (7) Video camera | (14) Salinometer |
| --- Limits of the laboratory | |

SURVEY NAME :

BOAT NAME :

DATE :

ESDU #	Time	Transect #	Speed	Computer record #	Video tape counter #	Species and length group (Small :S; Medium :M ; Large : L)																
						H.a.			H.s.			H.r.			H. spp.			Un Know			Other	
						Ind	Dis	Sch	Ind	Dis	Sch	Ind	Dis	Sch	Ind	Dis	Sch	Ind	Dis	Sch		
1	8:05	1	7	1	110	M5																
2	8:10	1	7	2	162					S1												
3	8:15	1	7.5	3	215																	
4	8:20	1	7.5	4	259																L3	
																						Dolphin

Fig. 3 - Example of the main log-Sheet for a visual survey. (Ind : Individual fish ; Dis : dispersed fish ; Sch : School)

EQUIPMENT

Boat

The boat should be large enough to allow long trips far offshore, a total crew of around 12 people for working by rotations over 24 hours, and a small laboratory. In order to obtain comparable results between surveys, it is essential to use the same boat because the flying behaviour probably differs from one boat to the other, according to undetermined parameters (size of the boat, color, noise frequency and intensity, etc.). The hull of the boat must be cleaned before the survey because different degrees of fouling may change the boat noise and therefore modify the flight signal intensity. Under ideal conditions, a recording of the boat noise spectra should be conducted (Bercy, 1984).

Video camera

A high resolution video camera is desirable. It is easier, for technical reasons, to find such equipment in black and white. Some preliminary trials should be done to determine whether or not lack of color is compensated for by an increase in the resolution. These trials should be done with different species and for different sea colors. The angle of the objective is also very important and must be chosen according to the camera resolution and the sampling methodology (total surface, sample, and eventually subsample).

If possible the camera should have an internal clock which displays the time and the date on the screen and records this information on the video tape. An alternative solution is to get this information directly from the tape. This feature makes the videocassette identification and sequence finding safer and easier. A connected keyboard for printing titles is another useful feature (but less essential).

A polarizing filter would be useful in limiting the disturbance from sun light reflected on the sea surface.

The camera stabilization system must be studied in detail in order not only to provide a stable view but also to provide a constant location of the view with respect to the boat. A gimble system with an heavy weight may give satisfactory results.

Viewfinder

The viewfinder should give the same field of view as the camera lens. In a small boat with sharp rocking motion, it may be very uncomfortable for the observer to use the viewfinder for a long watch. In such a case, large lateral boards may be used instead of a viewfinder, for limiting the field of view to a predetermined angle. Such boards must also be used during the initial methodological surveys with two observers surveying each side of the boat (fig. 4).

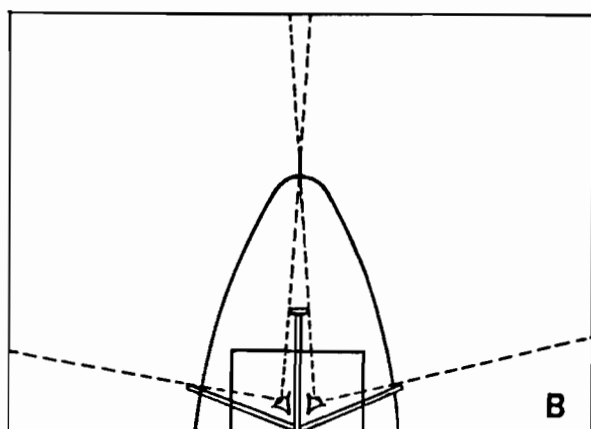
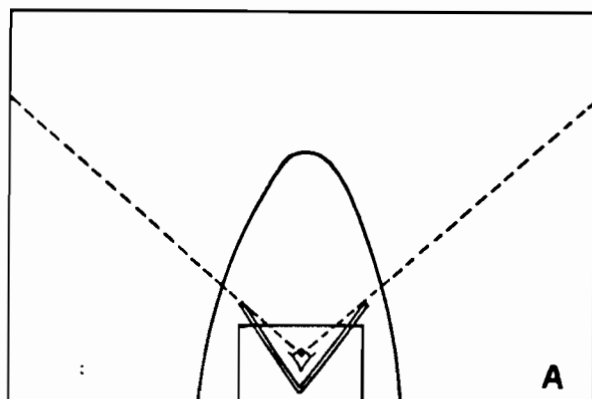

Fig. 4 - Limitation of the field of view by boards for one (A) or two (B) observers placed on the cabin roof of the boat.

TV monitor

An ordinary TV set can be used on the boat. A large screen with high definition is recommended for fish counting back at the laboratory.

Video recorder

An ordinary video tape can be used. It must have a precise revolution counter with digital display allowing connection to the computer. Slow motion must be an available option. Also frame by frame playback must be possible.

The recent development of videodisks and compact disks or optical disks using a laser may allow more convenient storage with a large capacity and a fast random access.

Microphone

The microphone must be directional and protected against wind disturbances. An intercom system could replace the simple system presented on figure 1 and would have the advantage of allowing communication from the laboratory to the observer.

Computer and peripheral devices

An ordinary desktop computer can be used with a small printer for editing the recorded parameters during each ESDU (useful for control and as a back-up). An internal clock would be useful if the time trigger does not come from the camera or from the video recorder. If a small boat is used for the survey, taking a hard-disk on board is not recommended, unless portable equipment is available. A floppy-disk reader using 3.25 inch diskettes is satisfactory at sea. The most important criterium for choosing the computer is the ability to interface it with the electronics equipment used for measuring the environmental parameters. The number of slots for parallel and/or series interfaces must be large enough, and the acquisition speed (number of bauds per seconds) must be consistent with those of the electronic equipment. A multi-task computer would allow data input from the keyboard (such as swell direction, colour of the sea, ...) during the automatic acquisition of other parameters.

A plotter would be very useful for mapping results after the survey.

Navigational aids

A satellite navigator is strongly recommended because it allows quick and efficient navigation with the actual position of the boat immediately available and automatically recordable on the computer. In addition it can provide other other useful information such as the time, date, boat speed and drift.

Meteorological station

The automatic meteorological stations provide air temperature (dry and wet), subsurface water temperature, wind direction and speed. The last two parameters may or may not be corrected according to the boat course and speed. If not, this can be done later with the computer.

Fishing gear

The normal fishing gear used by local fishermen can be used. Nevertheless, for a survey the criteria for gear selection are different from those of a commercial fishery. The catching efficiency of the gear is not as important as its low selectivity and its handling speed when a second fishing boat is not used during the survey. The monofilament gill-net is one of the most often

employed gear types (Harding, 1985) despite its selectivity. Hanging such a net above the water along the side of the boat by using two lateral masts, could be tried in order to see if it is possible to sample without stopping the boat.

It is recommended that special attention is paid to statistical data on the landing of commercial fishing boats during the survey period, with detailed information on the species, fish length, location of the catches, etc.

Floodlights

Powerful halogen floodlights are recommended. They will allow measurement of water transparency with a vertical tube, foil or the Secchi disk, even though this measure will have to be intercalibrated with daytime measurements.

DATA PROCESSING AND ANALYSIS

Four main steps must be carried out at the marine laboratory after the survey : data interpretation and storage (especially for the density estimation), abundance mapping, abundance estimation and fish length estimation.

Data interpretation and storage

After the survey, it will not be necessary to playback the whole video tape at the marine laboratory. Two situations require only the visual data given by the observer during a particular ESDU :

- the sequences without fish detection at all (probably more than half of the ESDU),

- and the sequences with nothing other than individual flight detections spaced far enough apart to allow reliable counting and a good communication between the observer and the "lab scientist" at sea.

For the other ESDU the playback of the videotape must be used if more than a rough mapping of the resource is needed.

Two approaches can be used for estimating the density, namely :

- the static approach using some sampled individual frames
- and the dynamic approach using the total recording for tracking the fish movements.

The static approach would consist of randomly sampling some frames on a time basis, and then counting the number of fish on the screen. It should be indicated whether the take-off starting point and direction are randomly distributed around the boat. At sea we usually observe a density gradient of the take-off distribution around the boat, and a strong polarization of the flight direction related to the avoidance behaviour of the fish and to the wind direction. These phenomena limit the use of the static

approach but some methodological studies may help to correct the subsequent bias. Using a frontal view, the major bias would be an overestimation of the density when the fishes are "pushed" by the boat and go along with it for some distance, remaining in the picture longer than in the theoretical case of a random distribution of the flights. If the flight distribution is symmetrical with respect to the longitudinal boat axis, a lateral view could reduce this bias.

Another disadvantage of the static approach is the poor quality of the frames provided by stopping the videotape reading. Sophisticated equipment enables both video recording and photographs to be taken with the same lens, but the cost of printed photographs would be too high for a reasonable sampling density. A 16 mm camera used for sampling at a low rate (one view per 30 seconds for example) would be a less expensive solution. The use of current video technology for pictures that give a high resolution at a reasonable cost should be investigated.

The dynamic approach is in fact the one used by the observer counting the number of fish appearances at the sea surface. The main inconvenience of this method is the difficulty of counting when the density is high and when the boat is moving under bad weather conditions, especially if a long focal length lens is used. Two techniques of counting the number of fish can be used :

- counting only the number of fish take-offs at the moment they jump out of the water,

- or counting the total number of fish on the screen, both crossing the sea surface when taking-off or entering the screen from one side when the take-off occurred off the screen.

The first technique seems the more appropriate one if absolute density estimation is required. Indeed, it overcomes the bias introduced by the movement of the fish relative to the boat. The two main inconveniences of this technique are that it reduces the number of fish counted and it is difficult to apply because the instant of take-off is not easy to capture on film. Before opening its lateral fins ("wings"), the fish is hard to detect because of the low contrast between the color of its back and the color of the sea. Repeated play-backs will be necessary to separate the true take-offs on the screen from the ordinary flights crossing the screen.

The second technique of total counting is much easier to use. The main disadvantage is making a reliable inference to the real fish density. For a survey aimed at providing a relative biomass, this technique seems suitable. If an absolute biomass is needed, then further methodological studies must be carried out in order to provide the conversion factor to estimate the fish density from the total flight count, as intended by Zuyev and Nikol'skiy (1980).

In the following section, **C** designates any conversion factors corresponding to any approach or counting technique allowing the real density to be calculated from the counting, and **M** indicates the number of fish counted during an ESDU within a certain

field of view. Then the estimated density ρ is :

$$\rho = CM$$

Abundance mapping

A typical chart showing an actual survey design together with the plotted M values is presented in figure 5 from Gerlotto (1986). From this map subsequent analysis proceeds along two lines, one aimed at data presentation, the other at deriving absolute estimates. Other presentations of the distribution results, such as : geographic maps, bar graphs or three dimensional representations, are reviewed by Johannesson and Mitson (1983).

Abundance estimation

The equation for flyingfish abundance N_B within the area A of the survey, can be written in a simple form when considering only one species :

$$N_B = \bar{\rho}_A \int A \, dA$$

where $\bar{\rho}_A$ is the mean value of fish density observed per EDSU within the area A and expressed in numbers of fish.

The equation for fish biomass W_B can be written as :

$$W_B = \Sigma w \bar{\rho}_A \int A \, dA$$

where w is the mean weight of the length group of the given species, estimated from the length-weight relationship.

Several methods are commonly used on acoustic surveys to apply the previous formulae to a real case. The two traditional methods, namely : algebraic method and geometric method are based on the assignation of each sample observation ρ_i to a corresponding rectangular area called "elementary statistical sampling rectangle" (ESSR). For a parallel survey pattern with equidistant inter-transect spacing, all the ESSRs have the same area size and are crossed in the center by the transect (fig. 5). The calculation of the mean of all the ρ_i observations is given by :

$$\rho = \frac{1}{n} \sum_{i=1}^n \rho_i$$

and the total biomass :

$$W_B = \rho n A = \rho n \text{ ESSR}$$

The only difference between the two methods is the use of the null ρ_i values. More detail on these two methods and on the post-sampling stratification technique are given by Johannesson and Mitson (1983). This last technique is useful when the fish distribution is heterogeneous in terms of mean density and variance, which is generally the case for pelagic fish.

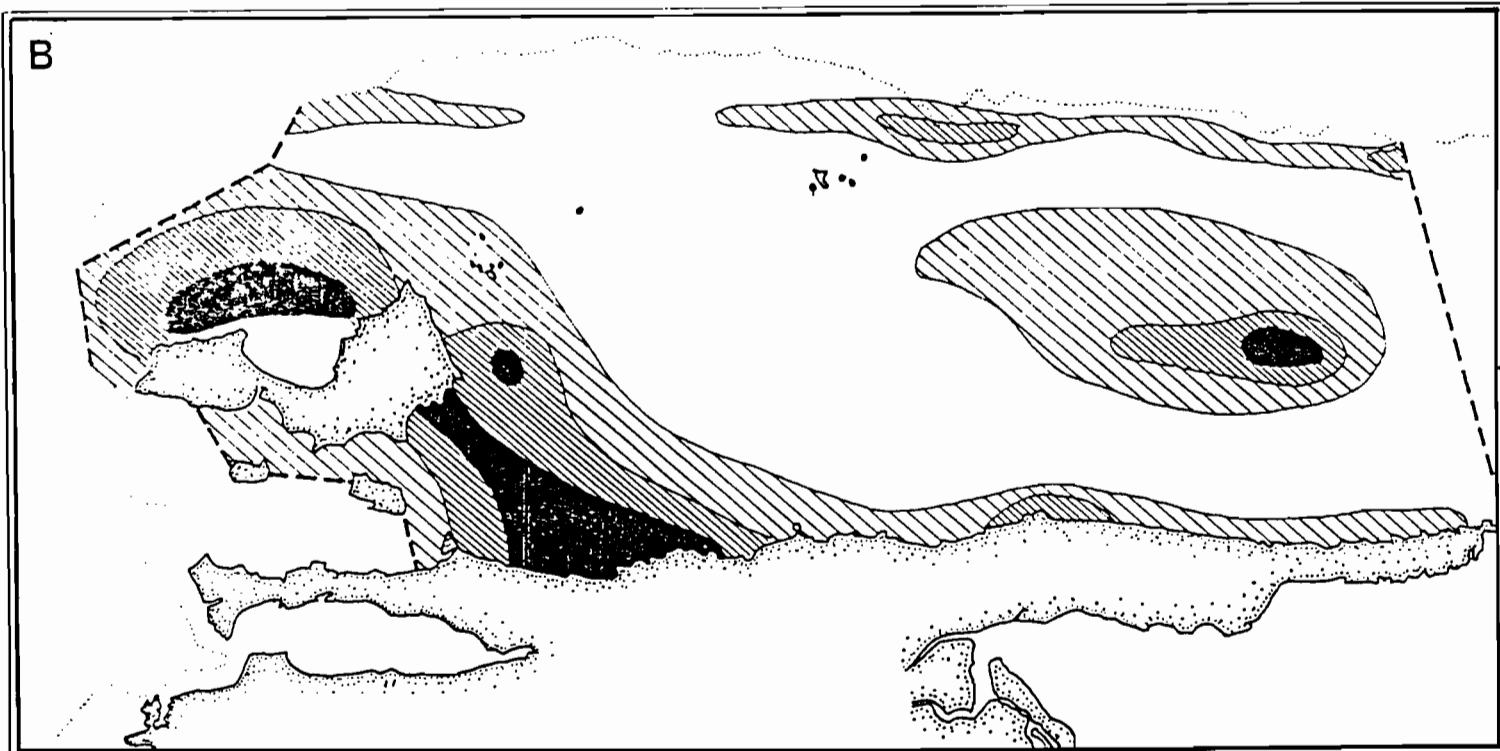
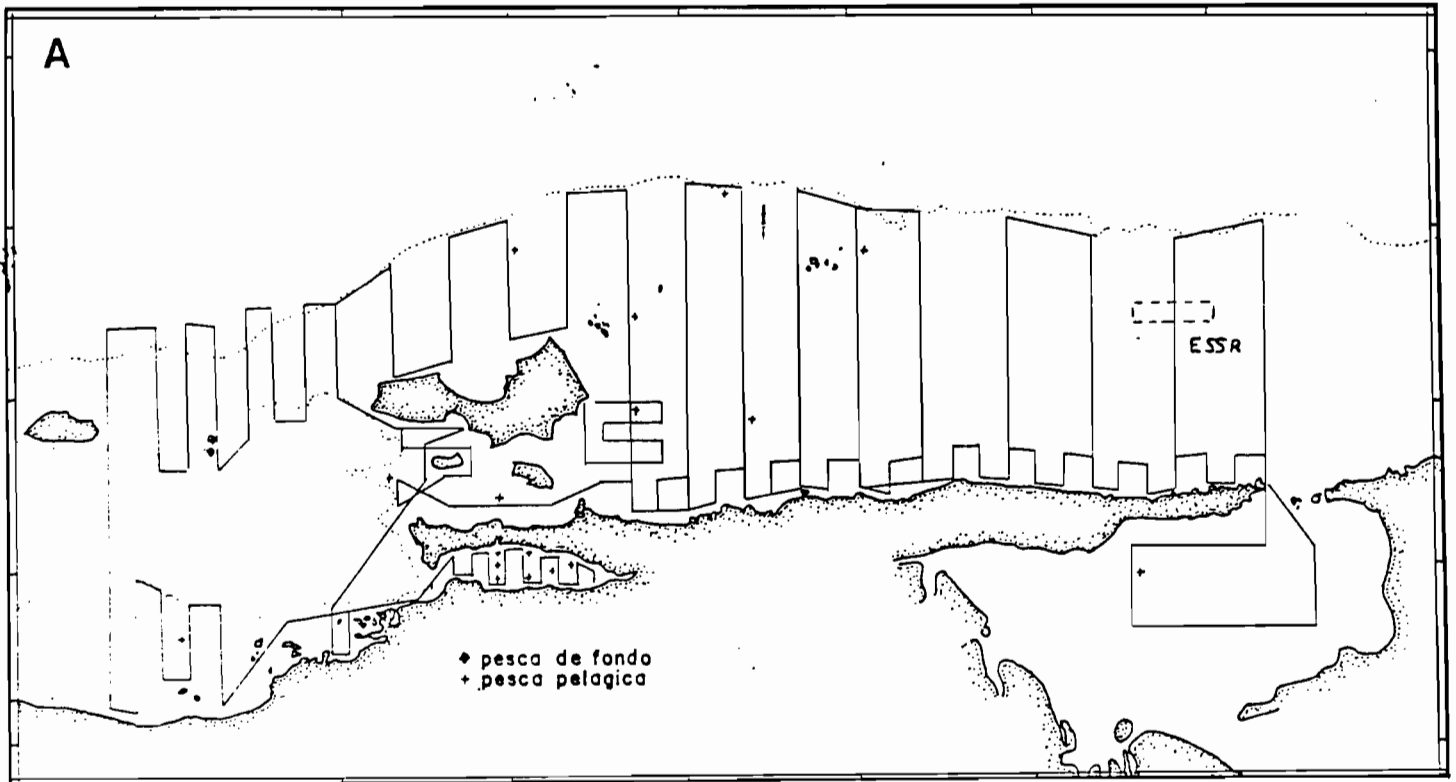

0/5
 6/30
 31/100
 >100
 (relative density index in arbitrary units)

Fig. 5 - Example of acoustic survey mapping (from Gerlotto pers. com.)

A - survey design
 B - density mapping

More recently other survey designs have been proposed with new and different data processing techniques allowing a more flexible design and a greater precision in the biomass estimate and in the confidence intervals, as earlier mentioned. Instead of using ESSRs with two dimensions equal to the ESDU and to the inter-transect distance, the dimension and the position of the ESSR's are fixed independently, in order to obtain a relative independence between the density of each ESSR. MacLennan and MacKenzie (1985) use for instance 20 mile-square ESSRs. In this case any ESDU falling inside a particular ESSR will be used for the calculation of the mean density.

As the usual assumption of normal distribution of the p_i values is generally not true, different techniques of variable transformation are used for acoustic surveys. The observed distributions generally present a positive skewness. They can be expressed by several mathematical models such as : the negative binomial, Polya-Aeppli, Neyman and Poisson distribution, listed in order of decreasing positive skewness (Elliott, 1971; Barbieri-Bellolio, 1981). The negative binomial distribution is probably the most suitable model for flyingfish stocks.

Several workers have shown that the assumption of independence between successive observations of acoustic density is not valid. Bazigos (1976) showed that the auto-correlation of the series has an inflationary effect upon the variance. Nickerson and Dowd (1977) proposed to use a model given by Hogg and Craig (1968) to correct such a bias, while Shotton and Dowd (1975) suggested the use of the cluster sampling estimate of Hansen *et al.* (1953). This last technique has been used from a simulated study by Williamson (1982). Johannesson and Mitson (1983) apply this approach to a real data set. The use of spacial analysis techniques, also called geostatistical approach, using variograms, has been recommended for pelagic fish abundance estimation, allowing a better variance estimation when the fish are strongly aggregated (Gohin, 1985)

Age size group determination

In addition to the rough estimate made by the observer at sea, a more precise estimation of the fish length can be done at the marine laboratory using the video recording. It is easy to calculate the fish length using trigonometric properties from the following data :

- camera focal length
- camera azimuth
- camera height above the sea
- fish height above the sea
- fish tilt angle
- position of the fish in the field of view

Another approach is to calibrate the camera directly at see for a fixed position and to use simply a scaling factor. In the case of Hirundichthys affinis with allometric growth, this feature can be used for a direct estimation of the size group.

In both cases the final length estimation can be obtain quickly using view processing software and a mouse or a lighth pencil on the computer.

THE NEED FOR FURTHER METHODOLOGICAL STUDIES

From the above presentation of the possibility of using visual observations for assessing flyingfish stock abundance, it is obvious that many uncertainties remain. Except for just roughly mapping the resource, the other objectives need a good estimate of the C conversion factors for each species. Methodological experiments using divers, underwater cameras and perhaps echosounders to assess school size and position must be continued. These experiments must take as model the behaviour experiments conducted by the scientists in charge of acoustic survey on a school when a research boat is passing close to it (Olsen, 1979, 1987; Diner, 1987; Godo and Ona, 1987; Misund, 1987). The usual difficulty with such experiments is to ensure that the observing devices (camera, diver or sonar, etc) do not interfere with the fish behaviour.

In order to avoid the presence of two sources of disturbance during the methodological experiments, the underwater observations may be done from the survey boat using a camera fixed under the bow which can record the fish behaviour before take-off. However, underwater cameras provide a short range of observation with generally poor definition. A bow observation chamber, like the one installed in the "Charles H. Gilbert" research vessel, would be more appropriate but more difficult to get. A literature review on the results obtained with the above vessel and other methods may give some useful information concerning flyingfish behaviour (Breder, 1929; Edgerton and breder, 1941; Akana et al., 1960; Strasburg and Yuen, 1960; Mann, 1961; Yuen, 1961; Zuyev and Nikolskiy, 1980), but as far as I know, except the clear evidence of the wind influence, the role played by others physical parameters is unknown. As well remains uncertain the main clue responsible for the fish reaction (vessel noise for some scientists, sight of the boat or lateral extend of the disturbing bow waves for others).

In order to determine if the engine noise is predominant in determining the fish behaviour compared with other sources of stress, an experiment using a sail boat and a motor boat at the same time could be done.

Some experiments or bibliographic studies on human vision must be carried out to establish the optimum field of view allowing reliable observation and counting of dispersed fishes. Obviously the lateral angle must not exceed 50°.

The new techniques of image processing using powerful desktop computers may lead to substantial improvement of the

methodology. The view stabilization may be solved by this way. Less obvious is the possibility of directly estimating the fish density by integrating optical changes.

In summary, the most important questions to answer before carrying out a large survey for biomass estimation are :

-which kind of boat should be used (size, facilities, etc.)?

-what is the optimal field of view for the observer and for the camera(s)?

-what is the optimal location of this field of view (lateral, frontal, distance from the boat)?

-how to delimit and stabilize this field of view?

-what is the optimal boat speed?

-what equipment specifications are required (focal length of the camera lens, interface characteristics for the computer peripherals, color charts, etc.)?

-what is the variability of the flight behaviour and which parameters control this variability? Special attention must be paid to :

(1) the proportion of fish taking-off

(2) the distribution of the flights with respect to the boat course (symmetrical or asymmetrical) and with respect to the distance from the boat

(3) the variation in flight length

(4) the number of flights per fish (statistical description of flight repetitions)

-how wide is the field of influence of the boat in terms of stimulating a fright reaction?

-from the above answers and according to the survey objective, which methodology must be used to estimate the fish density or an index of density?

The answer to these questions may lead to a mathematical model describing the conversion factor C such as:

$$C = f(W, \theta_1, H, \theta_2, \theta_3, A, V, S, T, N)$$

were W is the wind speed, θ_1 the angle between the boat course and the wind direction, H the swell height, θ_2 the angle between the boat course and the swell direction, θ_3 the angle between the boat course and the sun light, A the sun azimuth, V the boat speed, S the surface (or the volume) of the boat under the water, T the water turbidity, and N an index of the boat noise integrating the frequencies and the noise intensity. This list of parameters is preliminary: it may be incomplete and/or some parame-

ters mentioned may not have a significant effect.

CONCLUSION

This attempt to describe a methodological approach for a flyingfish abundance survey shows that many questions remain unanswered. Although much can be learnt from previous acoustic surveys (Venema, 1982) to save time and avoid some mistakes, it is obvious that large surveys cannot be successfully achieved without some preliminary methodological experiments. If these are not done, a loss of time and money will probably result from the first surveys. The methodology for obtaining relative abundance indices may be available after a few months of experiments, but for absolute biomass estimation many years of research would probably be necessary to reach a satisfactory method giving reliable confidence limits. After 20 years of multi-disciplinary international research, the acoustic method is just reaching this point.

However, if the variability of the flying behaviour of flyingfish resulting from the vessel stress is not too high, it may be possible to ask sportboats (motorboats or sailboats) or commercial vessels to carry out some observations of abundance and report them periodically. Such cooperation between oceanographers and commercial vessels has been successfully achieved for many years for recording temperature (subsurface and XBT) and meteorological data. A physical oceanographic data base is now available covering all the commercial ship routes around the world. Although such information would be subjective for flyingfish, it could be useful for a general mapping of the resource, especially outside the usual fishing grounds.

Visual methods of estimation, commonly used up to the end of the last century, have since been abandoned because they are generally less objective than techniques using modern equipment developed at the beginning of the 20th century. However, the new technology of recent years (video, computer) may result in a comeback of these methods still with a quantitative approach. Such an analysis explains the recent success of remote sensing techniques.

ACKNOWLEDGMENTS

I thank my colleague F. Gerlotto for helpful discussions and comments on the manuscript. I am grateful to Dr H.A. Oxenford for linguistic assistance and useful comments.

BIBLIOGRAPHY

Akana, A.K., Jr.H.J. Mann and R.E.K.D. Lee, 1960. Research vessel is fitted for underwater observation of fish. **Pacific Fisherman**, 58 (8) :8-10

Barbieri Bellolio, M. A., 1981. Variabilité des données acoustiques utilisées dans l'évaluation des biomasses halieutiques par écho-intégration. **Thèse Doctorat d'Etat, Université de Bretagne Occidentale** :197 pp

Bazigos, G.P., 1976. The design of fisheries statistical surveys-inland waters. Populations in non-random order, sampling methods for echo survey, double sampling. **FAO Fish.Tech.Pap.**, 133 (suppl. 1) :46pp

Bercy, C., 1984. Campagne germonière 1983. Synthèse de l'étude acoustique menée sur 65 bateaux de la flotille de pêche. **Rapport GERBAM, Université Pierre et Marie Curie, Paris** :26pp

Breder, C.M., 1929. Field observations on flying fishes : a suggestion of methods. **Zoologica**, 9 (7) :295-312

Diner, N. and J. Masse, 1987. Fish school behavior during echo survey observed by acoustic devices. **International symposium on fisheries acoustics, June 22-26, 1987, Seattle, Washington, USA (mimeo)**.

Edgerton, H.E. and C.M. Breder, 1941. High speed photographs of flying fishes in flight. **Zoologica**, 27 (30) :311-314

Elliot L.M., 1971. Some methods for the statistical analysis of samples of benthic invertebrates. **Sci.Publ.Freshwater.Biol.Assoc.**, Ambleside, UK, 25 :

Fabres, B., 1986. Bibliography on flyingfish biology and related topics. In **Proceedings of an IDRC-sponsored workshop at the University of the West Indies, Cave Hill, Barbados**, R. Mahon, H. Oxenford and W. Hunte (eds), IDRC-MR 128e :43-50

Fiedler, P.C., 1968. The precision of simulated transect surveys of northern anchovy, **Engraulis mordax**, school groups. **Fish.Bull.NOAA:NMFS**, 76(3) :679-685

Gerlotto, F. et B. Stéquert, 1983. Une méthode de simulation pour étudier la distribution des densités de poissons : application à deux cas réels. In **Nakken, O. and S.C. Venema (eds). Symposium on fisheries acoustics. Selected papers of the ICES/FAO symposium on fisheries acoustics. Bergen, Norway, 21-24 June 1982, FAO Fish. Rep.**, 300 :278-292

Godo, O.R. and D. Ona, 1987. Fish behavior to trawling noise : the significance of trawl sampling. **International symposium on fisheries acoustics, June 22-26, 1987, Seattle, Washington, USA (mimeo)**.

Gohin, F., 1985. Geostatistics applied to fish distribution as derived from acoustic survey. **ICES/FAST working group. Meet.**, Tromsø, 22-24 may 1985 :6 pp

Hansen, M.H., W.N. Hurwitz and W.G. Madow, 1953. Sample surveys methods and theory. New York, John Wiley and Sons, 2 vols.

Harding, A., 1986. Past developments and present techniques in the Barbados flyingfish fishery. In Proceedings of an IDAC-sponsored workshop at the University of the West Indies, Cave Hill, Barbados, 22-23 October 1985, R. Mahon, H. Oxenford and W. Hunte (eds), IDAC-MR 128e :27-28

Hogg, R.V. and A.T. Craig, 1968. Introduction to mathematical statistics. New York, Mcmillan, :384pp

Hubbs, C.L., 1933. Observation of the flight of fishes with a statistical study of the flight of the Cypselurinae and remarks on the evolution of the flight of fishes. In McCartney, S.C. and P. Okkelberg (eds.). Papers of the Michigan Academy of Science Arts and Letters, 17 :575-611

Hubbs, C.L., 1937. Further observations and statistics on the flight of fishes. In McCartney, E.S. and A.H. Stockard (eds.). Papers of the Michigan Academy of Sciences, Arts and Letters, 22 :641-660

Johannesson, K.A. and R.B. Mitson, 1983. Fisheries acoustics. A practical manual for aquatic biomass estimation. **FAO Fish.Tech.Pap.**, 240 :249 pp

Jolly, G.M. and I. Hampton, 1987. Some common misconceptions in the statistical design and analysis of acoustic surveys to assess fish biomass. International Symposium on Fisheries Acoustics, June 22-26, 1987, Seattle, Washington, USA (mimeo).

Laloé, F., 1985. Contribution à l'étude de la variance d'estimateurs de biomasse de poissons obtenus par écho-intégration. **Océanogr. trop.**, 20 (2) :161-169

MacLennan, D. N. and I. G. MacKenzie, 1985. Precision of results from acoustic surveys. **Cons.Int.Explor.Mer**, CM 1985/B:17, Acoustic theme :14 pp

Mahon, R., 1986. Seasonal and interannual variability in abundance of flying fish. In Proceedings of an IDAC-sponsored workshop at the University of the West Indies, Cave Hill, Barbados, R; Mahon, H. A. Oxenford and W. Hunte (eds), IDAC-MR 128e :89-130

Mahon, R., H. Oxenford and W. Hunte, 1986. Development strategies for flyingfish fisheries of the eastern caribbean. Proceedings of an IDAC-sponsored workshop at the University of the West Indies, Cave Hill, Barbados, 22-23 October 1985, IDAC-MR 128e :148 pp

Mann, H.J., 1961. Underwater observation chambers on the research vessel "Charles H. Gilbert". In J.O. Traung and N. Fujinami (eds.), "Research Vessel Design", **FAO Research Vessel forum**,

Tokyo, Sept. 18-30, 1961 :pp. MAN 1-9

Misund, D.A., 1987. Sonar observations of the horizontal shape and swimming behavior of herring schools. International symposium on fisheries acoustics, June 22-26, 1987, Seattle, Washington, USA (mimeo).

Nesterov, A.A. and M.Y. Grudtsev, 1981. The quantitative distribution of the flyingfish of the family Exocoetidae (Beloniformes) in the tropical Atlantic. *J. Ichtyol.* 20 (3) :137-140

Nickerson, T.B. and R.G. Dowd, 1977. Design and operation of survey patterns for demersal fishes using the computerised echo counting system. *Rapp.P.-V.Réun.CIEM*, 170 :232-236

Olsen, K., 1979. Observed avoidance behaviour in herring in relation to passage of an echo survey vessel. *ICES CM.1979/B:18* :21p.(mimeo).

Olsen, K., 1987. Fish behavior and acoustic sampling. International symposium on fisheries acoustics, June 22-26, 1987, Seattle, Washington, USA (mimeo).

Shotton, R. and R.G. Dowd, 1975. Current research in acoustic fish stock assessment at the Marine Ecology Laboratory. *ICNAF Res.Doc.75/16*, serial n° 3468 :17pp

Shuntov, V.P., 1973. On the distribution patterns of flyingfishes (Oxyporhamphidae and Exocoetidae) in the Pacific and Indian oceans. In: The tropical zone of the seas and oceans and the global processes associated with it. *Nauka Press*.

Strasburg, D.W. and H.S.H. Yuen, 1960. Progress in observing tuna underwater. *J.Cons.Perma.Int.Explor.Mer*, 26 (1) :80-93

Venema, S.C., 1982. A selected bibliography of acoustics in fisheries research and related fields. *FAO Fish.Circ.*, 748 :154 pp

Williamson, N.J., 1982. Cluster sampling estimation of the variance of abundance estimates derived from quantitative echo sounder surveys. *Can.J.Fish.Aquat.Sci.*, 39 (1) :229-231

Yuen, H.S., 1961. Bow wave riding of dolphins. *Science*, 134 (8434) :1011-1012

Zuyev, G.V. and V.N. Nikol'skiy, 1980. Procedure for the quantitative recording of flyingfishes (Exocoetidae). *J.Icht.*, 20 (6) :147-149

LISTE DES LABORATOIRES DU POLE

GUADELOUPE

U A G
Laboratoire de Biologie Animale
Laboratoire de Géologie Marine
B.P. 592
97167 POINTE A PITRE Cedex
Tél. (590) 82 45 29 - 82 58 06
Télex : UNIVAG 919 739 GL

ORSTOM / IFREMER
B.P. 1020
97178 POINTE-A-PITRE
Tél. (590) 82 05 49
Télex : 919 231 GL

GUYANE

IFREMER
B.P. 477
97302 CAYENNE
Tél. (594) 31 77 30

ORSTOM
B.P. 165
97323 CAYENNE
Tél. (594) 31 27 85
Télex : ORSTOM 910 608 FG

MARTINIQUE

IFREMER
Pointe Fort
97231 Le ROBERT
Tél. (596) 65 11 54/56
Télex : IFREMER 912 488 MR

ORSTOM
B.P. 81
97256 FORT-DE-FRANCE Cedex
Tél. (596) 70 28 72
71 71 18
Télex : ORSTOM 912 024 MR

VENEZUELA

ORSTOM
Apartado 373
CUMANA - 6101 - SUCRE
Tél. (093) 22294/ext. 129

POLE DE RECHERCHE OCEANOLOGIQUE ET HALIEUTIQUE CARAIBE

Cette entité scientifique est née en 1985 de la mise en commun des capacités locales de recherche de l'IFREMER (Institut Français pour l'Exploitation de la Mer), de l'ORSTOM (Institut Français de Recherche Scientifique pour le Développement en Coopération) et de l'UAG (Université des Antilles et de la Guyane).

Son objectif est de :

- promouvoir, mettre en œuvre et coordonner les recherches concernant le milieu, la gestion des ressources vivantes, le développement et l'aménagement de leur exploitation dans la zone caraïbe ainsi que la connaissance et la conservation des écosystèmes.

Ses recherches portent, actuellement, sur l'étude des écosystèmes marins, l'évaluation et l'aménagement des pêcheries artisanale et industrielle, l'aquaculture des mollusques, crustacés et poissons.

Ses laboratoires se situent en Guadeloupe, Guyane et Martinique et des chercheurs du Pôle peuvent être accueillis dans différents laboratoires par des équipes de pays voisins dans le cadre d'accords bilatéraux de coopération (voir en dernière page la liste des laboratoires et antennes).

This scientific entity was born in 1985, resulting from the local association of three national research institutes : IFREMER (Institut Français de Recherche pour l'Exploitation de la Mer), ORSTOM (Institut Français de Recherche Scientifique pour le Développement en Coopération) and UAG (Université des Antilles et de la Guyane).

Its aim is to advance, realize and coordinate the research concerning the physical oceanography, the management of living resources, the development and planning of their use in the caribbean area as well as the understanding and protection of their ecosystems.

Its research programs deal with : the study of marine ecosystems, the evaluation and planning of the small scale and industrial fisheries and the aquaculture of molluscs, crustaceans and fish.

The laboratories belonging to this group are situated in Guadeloupe, French Guyana and Martinique, but the scientific teams can be based in other laboratories of neighbouring countries through cooperative joint-ventures. (See laboratories index on the last page).

Esta entidad nació en 1985 de la confluencia de las capacidades locales de investigación del IFREMER (Institut Français pour l'Exploitation de la Mer), del ORSTOM (Institut Français de Recherche Scientifique pour le Développement en Coopération) y de la UAG (Universidad de las Antillas y la Guyana francesas).

Su objetivo es promover, realizar y coordinar las investigaciones tocantes al medio, a la administración de los recursos vivos, al desarrollo y al fomento de su explotación en el área del Caribe así como al conocimiento y a la conservación de los ecosistemas.

Sus investigaciones actuales conciernen el estudio de los ecosistemas marinos, las evaluaciones y ordenación de las pesquerías artesanal e industrial, el cultivo acuático de los moluscos, crustáceos y peces.

Sus laboratorios se ubican en Guadeloupe, Guyana y Martinica y sus investigadores pueden laborar en varios laboratorios con equipos científicos de los países vecinos en el marco de convenciones bilaterales de cooperación. (Ver la lista de los laboratorios en la última página.)