

Analyse Non Linéaire et Modélisation
97/15

A Model of Sleeping Sickness : Open Vector

Populations and Rates of Extinction

M. ARTZROUNI - J.-P. GOUTEUX

Fonds Documentaire ORSTOM



010012170

Fonds Documentaire ORSTOM

Cote : ~~B*12~~ 170 Ex: 1

A MODEL OF SLEEPING SICKNESS: OPEN VECTOR POPULATIONS AND RATES OF EXTINCTION

MARC ARTZROUNI
Department of Applied Mathematics (IPRA)
University of PAU
64000 Pau
FRANCE

JEAN-PAUL GOUTEUX
ORSTOM (IPRA)
University of PAU
64000 Pau
FRANCE

e-mail: marc.artzrouni@univ-pau.fr

ABSTRACT

A compartmental model of sleeping sickness is described that takes into account a density-dependence of the vector population which is subjected to a regulating migratory mechanism. The analysis of the model focuses on the stability of the origin, which is assessed through the growth rate ev_5 of the infected populations. This growth rate is negative if and only if the basic reproduction number R_0 is less than 1. (In such a case we call ev_5 the extinction rate). However ev_5 and R_0 do not change in a consistent fashion. An example shows that a lowered R_0 (which may seem a desirable result) can actually slow down the extinction of the epidemic. We thus argue that ev_5 may be a better criterion for extinction than R_0 since it takes into account in a consistent fashion the time to extinction. This is an important factor in the study of control strategies which must be used over a period of time. The results are illustrated with numerical examples, and the consequences for control strategies are briefly discussed.

Keywords: Compartmental model, sleeping sickness, differential equations, basic reproduction number, extinction rate.

1. Introduction

Sleeping sickness (or African human trypanosomiasis) is endemic in 36 countries of Sub-Saharan Africa. There is currently a resurgence of this disease in Central Africa and it is estimated that approximately 50 million people are exposed to sleeping sickness (Cattand, 1994). Mathematical models can help better understand the dynamics of this vector-borne disease which is transmitted through tsetse flies. In his pioneering work Rogers developed a general model of Africa trypanosomiasis (Rogers, 1988a, 1988b, 1989).

More recently we have proposed a five-compartment differential equations model for *Trypanosoma brucei gambiense*, the Gambian form of sleeping sickness that affects western and central Africa (Artzrouni and Gouteux, 1996a). Unlike Rogers who considers both human and parasite reservoirs, we consider only human hosts. We make this simplifying assumption because there is epidemiologic evidence to suggest that animal reservoirs play a negligible role during an epidemic of Gambian trypanosomiasis (Kageruka, 1989; Noireau *et al.*, 1986; Zillmann *et al.*, 1984). Indeed, there is no or little correlation between human and animal prevalence rates (see Authier *et al.* (1991) for a review). The model takes into account the incubation periods of both humans and flies, and assumes that both populations remain constant. This model also enabled us to investigate control strategies in some detail (Artzrouni and Gouteux, 1996b; Gouteux and Artzrouni, 1996).

In this paper we propose a variant of the model that no longer assumes the vector population is closed and constant. The model's realism increases when considering a density-dependence of the vector population which is subjected to self-regulating migratory exchanges. These exchanges play a vital role in the population dynamics of vectors (Hargrove, 1981; Turner and Brightwell, 1986; Rogers *et al.*, 1984; Dransfield and Brightwell, 1989). Modeling the control of the epidemic through additional vector mortality then becomes more realistic when the population is considered open.

We will also investigate in detail the rate of extinction of the disease. Indeed, field observations show that the infected populations can evolve very slowly, and an investigation into the rate at which the disease disappears (or spreads) should help in our understanding of the persistence of sleeping sickness in historical foci of the past. (Gouteux *et al.*, 1993; Frezil and Coulm, 1976; Frezil and Cuisance, 1994).

The paper is organized as follows: Section 2 below describes the model and its various ingredients (in particular a new approach to the fly bite rate). The main theorem concerning the rate of extinction is presented in Section 3. Section 4 is devoted to a discussion of the results and to a numerical example that illustrates how the rate of extinction can be used to compare and assess control strategies. The paper closes with a brief conclusion in Section 5.

2. The Model

2.1. General description

We consider an "epidemiologic unit" made of an isolated village surrounded by an open population of tsetse flies. There are three vector compartments and three human compartments (Figure 1). $V_s(t)$, $V_i(t)$, $V_a(t)$ are the susceptible, incubating, and actively infected vectors at time t (vectors can transmit the parasite only during this last stage); $V(t) = V_s(t) + V_i(t) + V_a(t)$ is the total vector population.

The human variables are $H_s(t)$, $H_a(t)$, $H_r(t)$: susceptible, asymptomatic carriers, and removed humans at time t . (We ignore the incubation period for humans which is approximately 12 days; this is a short period compared to the duration of the asymptomatic phase which can last several months to several years). Only those in the compartment of asymptomatic carriers can transmit the parasite through fly bites. When these carriers enter the second phase of the disease (meningo-encephalitic phase) or go to hospital for treatment, then they are removed because their risk of being bitten and transmitting the parasite becomes negligible. Thereafter they re-enter the susceptible population when they are cured. (Or if they die in the removed compartment we consider that they are

replaced by the same number of humans (through births) in the susceptible compartment, which is mathematically equivalent to a recovery). All humans, except the removed ones, are at risk of being bitten by a fly (and can therefore be infected by a fly when in the susceptible stage and transmit the parasite while in asymptomatic stage).

Because the human population is assumed constant and equal to $H = H_s(t) + H_a(t) + H_r(t)$, we note that the system with six compartments can be reduced to five variables (and therefore five equations).

We consider a continuous-time model where the unit of time is three days: this is a convenient unit because it is the average time between blood meals for a fly.

2.2. The fly bite rate model

Tsetse flies have on average one blood meal every three days either on humans, or preferably on animals. Suppose there is a pool of A_0 animals that a fly may bite. At time t there are also $H - H_r(t)$ humans that a fly may bite. We assume that a fly's preference for animals is measured by a weight factor w that is between 0 and 1, where 0.5 indicates indifference between the two groups. The probability τ_1 of biting a man during one time unit (i.e. one three-day interval) is then a function of the number of removed individuals $H_r(t)$:

$$\tau_1(H_r(t)) = \frac{(H - H_r(t)) \times (1 - w)}{(H - H_r(t)) \times (1 - w) + wA_0} = \frac{H - H_r(t)}{H - H_r(t) + wA_0/(1 - w)} \quad (1)$$

We can thus consider that each fly bites with equal probability either one of $H - H_r(t)$ humans or one animal out of a fictitious population of $A \equiv wA_0/(1 - w)$ animals. The probability that a fly will bite an infected individual is then $H_a(t)/[H - H_r(t) + A]$ and that it will bite a susceptible one is $(H - H_a(t) - H_r(t))/[H - H_r(t) + A]$.

2.3. The population dynamics of vectors

We assume that flies have constant birth and mortality rates b and m . In addition we assume a simple regulating migratory mechanism: during a time interval dt the net growth of the susceptible vector population due to migration is of the form $k(V_c - V(t))$; $k \geq 0$ measures the strength of the feedback (i.e. the magnitude of the migratory flows) and V_c is a critical value of the total population below which there is in-migration, and above which there is out-migration. We assume for simplicity that migrations occur only in the susceptible compartment: healthy flies alone migrate. This assumption is not unreasonable given that even during an epidemic the overwhelming majority of flies remains uninfected (Jordan, 1976).

Flies can become infected primarily during their first blood meal (i.e. while in the first three-day age group). Given that the number of flies in this first age group is approximately $V(t)b$, the number of flies at risk of infection is also $V(t)b$.

The equation for the incubating fly population is then

$$\frac{dV_i(t)}{dt} = \frac{V(t)b\tau_2 H_a(t)}{H - H_r(t) + A} - V_i(t)(q+m) \quad (2)$$

where the first term on the right-hand side represents the newly infected vectors. Indeed, $H_a(t)/(H - H_r(t) - A)$ is the probability of biting an infected individual, and τ_2 is the probability that a susceptible vector eventually becomes infected after biting an infected human; τ_2 reflects the "intrinsic vectorial capacity" (Leray, 1989) as well as an average probability of infection that ignores each patient's periodic parasitemic fluctuations (which are caused by the parasite's antigenic variations). Finally q is the rate at which vectors leave the incubating stage and $1/q$ is therefore the average durations of the incubation period. The term $V_i(t)(q+m)$ thus reflects losses due to new infections and deaths.

Changes in $V_a(t)$ occur only through new active infections and deaths:

$$\frac{dV_a(t)}{dt} = V_i(t)q - V_a(t)m = [V(t) - V_s(t) - V_a(t)]q - V_a(t)m \quad (3)$$

The equation for the susceptible compartment is

$$\frac{dV_s(t)}{dt} = V(t)b \left(1 - \frac{\tau_2 H_a(t)}{H - H_r(t) + A} \right) + k(V_c - V(t)) - mV_s(t) \quad (4)$$

which captures gains due to births ($V(t)b$) and losses due to new infections as well as losses due to mortality within the compartment ($mV_s(t)$); $k(V_c - V(t))$ is the migration term.

Adding equations (2), (3), (4) yields

$$\frac{dV(t)}{dt} = V(t)(b-m) + k(V_c - V(t)) \quad (5)$$

Not surprisingly this is a differential equation in the single variable $V(t)$ that expresses the fact that the total population simply changes through migration and through the balance between mortality and natality.

When $k+m-b=0$ then $V(t)$ increases linearly if $b>m$ and remains constant when $b=m$ and $k=0$. When $k+m-b \neq 0$ the solution to the differential equation (5) is

$$V(t) = V_0 - (V_0 - V(0))e^{-(k+m-b)t} \quad (6)$$

where $V_0 = kV_c / (k+m-b)$. If $k+m-b < 0$ (with $b \geq m$ since $k \geq 0$) then the "migratory feedback" is not strong enough to counterbalance the excess natality and $V(t)$ increases without bound. If $k+m-b > 0$, then Eq. (6) is a classical growth equation used by Hargrove (1981) and others (Lebreton and Millier, 1982). The total population converges monotonically to its carrying capacity V_0 , whether the initial population $V(0)$ is greater or smaller than V_0 .

We will ignore the two cases that do not lead to an equilibrium vector population [$k+m-b=0$, $b>m$ (linear increase) and $k+m-b < 0$ (exponential increase)]. We will focus instead on the cases

C1: $k+m-b > 0$

C2: $k+m-b=0$ with $b=m$ and $k=0$.

Case C2 is the standard situation of a closed constant population with equal birth and death rates. In case C1 the fly population never disappears. Indeed, even if the fly population $V(t)$ is very small (or 0) then a continuous flow $k(V_c - V(t))$ replenishes the population until it reaches its carrying capacity $V_0 = kV_c / (k+m-b)$. This equilibrium population V_0 depends in particular on the mortality rate m : if m

increases (naturally or through vector control) the population does not go to extinction but reaches a lower equilibrium level. (Rogers *et al.* , 1984).

In forest areas where a focus may have no clear boundaries, the feedback parameter k may be larger which implies a V_0 that is larger and also less sensitive to changes in m . On the other hand, in a savanna focus which is more isolated, k (and therefore V_0) may be smaller, and V_0 will then be more sensitive to m .

2.4. The population dynamics of humans

The two equations for the human populations are:

$$\frac{dH_a(t)}{dt} = V_a(t)\tau_3 \frac{H-H_a(t)-H_r(t)}{H-H_r(t)+A} - H_a(t)r_1 \quad (7)$$

$$\frac{dH_r(t)}{dt} = H_a(t)r_1 - H_r(t)r_2 \quad (8)$$

where the first term on the right-hand side of Eq. (7) represents new human infections. Each one of the $V_a(t)$ actively infected fly has a probability $[H-H_a(t)-H_r(t)]/[H-H_r(t)+A]$ of infecting a susceptible person and τ_3 is the probability that a susceptible human bitten by an infected fly will become sick. (τ_3 is the "human susceptibility").

The parameter r_1 is the transition rate between the asymptomatic and the removed compartments. This transition reflects the natural history of the disease for infected individuals who move from the first asymptomatic stage to the meningo-encephalitic stage when the risk of transmitting the parasite becomes negligible. This transition also reflects the detection of infected individuals when they are removed to be treated.

Equation (8) is a routine balance equation for the removed compartment, where r_2 reflects the recovery of treated individuals. The susceptible population $H_s(t)$ is known through $H_s(t)=H-H_r(t)-H_a(t)$.

3. Main result

We define the system through the vector $P(t) = [V(t), V_a(t), V_s(t), H_a(t), H_r(t)]$ and the five differential equations (5), (3), (4), (7), (8). We note that the vector $W_0 = (V_0, 0, V_0, 0, 0)$ (which we call the "origin") is an equilibrium point of the system corresponding to the situation with no epidemic. [The variable $V_i(t)$ does not appear in this system but is known through $V_i(t) = V(t) - V_s(t) - V_a(t)$].

We define the quantity

$$R_0 = \frac{V_0^* b \tau_2 q \tau_1(0)^2 \tau_3}{m(q+m)r_1 H} \quad (9)$$

where V_0^* is V_0 in Case C1 and is $V(0)$ (the constant total population) in Case C2.

We note that $\tau_1^{\text{def.}} = \tau_1(0) = H/(H+A)$ is the fly bite rate when the removed compartment is empty. The quantity R_0 is the basic reproduction number of the epidemic, i.e. the average number of humans infected (via the flies) by a single newly infected person ("patient zero") when the total population has settled to an equilibrium value V_0^* and there are no infected vectors. Indeed, the quantity $R_1 = V_0^* b \tau_1 \tau_2 [r_1 H]$ is the number of flies that become infected since $V_0^* b$ flies each have a probability $\tau_1 \tau_2 / H$ of biting patient zero and becoming infected.

Furthermore, the duration of this exposure is $1/r_1$ (the time patient zero spends in the asymptomatic stage). Also $R_2^{\text{def.}} = \tau_1 \tau_3 (q/(q+m))/m$ is the average number of new human infections generated by each new infected fly (because $q/(q+m)$ is the probability of reaching the active infective stage, $1/m$ is the life expectancy once a fly has reached that stage and the probability of biting a susceptible human who will become infected is then $\tau_1 \tau_3$). R_0 is then the product $R_1 R_2$.

In the sequel we will show that the origin W_0 is unstable if $R_0 > 1$ and asymptotically stable if $R_0 < 1$. In this latter case we will give detailed results on the extinction rate of the disease, i.e. on the asymptotic rate at which each component of the vector $W(t) = P(t) - W_0$ approaches 0. For example if asymptotically $V_a(t) \sim e^{ct}$ for some $c < 0$, then we call c the extinction rate of the population $V_a(t)$. In an analogy with the doubling time of a population, we can then calculate the asymptotic "halving time" of the actively infected vector population which is $HT =$

$-\ln(0.5)/c$.

We will need the following parameters:

$$r = 2m + q + r \quad (10)$$

$$s = m(m+q) + r_1(2m+q) \quad (11)$$

$$t = m(m+q)r_1(1-R_0) \quad (12)$$

$$p^* = s - r^2/3 \quad (13)$$

$$q^* = 2r^3/27 - rs/3 + t \quad (14)$$

In the theorem we will make use of the fact that $p^* < 0$ (indeed p^* is a quadratic polynomial in the unknown $m-r_1$ and this quadratic is always negative).

THEOREM. The origin W_0 is asymptotically stable if $R_0 < 1$ and unstable if $R_0 > 1$. We next define

$$ev_5 = 2 \left(-\frac{p^*3}{27} \right)^{1/6} \cos \left(\frac{1}{3} \times \arccos \left(\frac{-q^*}{2} \left(-\frac{p^*3}{27} \right)^{-1/2} \right) \right) - \frac{r}{3}. \quad (15)$$

We assume $k+m-b > 0$ (Case C1). If $R_0 > 1$ then $ev_5 > 0$; if $R_0 < 1$ then $ev_5 < 0$ and the asymptotic growth rates (extinction rates) $\rho(V(t)-V_0)$, $\rho(V_a(t))$, $\rho(V_s(t)-V_0)$, $\rho(H_a(t))$, $\rho(H_r(t))$ of the five components of $W(t)$ are:

$$\rho(V(t)-V_0) = -k-m+b \quad (16)$$

$$\rho(V_a(t)) = ev_5 \quad (17)$$

$$\rho(V_s(t)-V_0) = \max [-k-m+b, ev_5] \quad (18)$$

$$\rho(H_a(t)) = ev_5 \quad (19)$$

$$\rho(H_r(t)) = \max [-r_2, ev_5] \quad (20)$$

When $k=0$ and $m=b$ (Case C2) then $V(t)$ is constant and the right-hand sides of Eqs. (17), (19), (20) remain unchanged. The right-hand side of Eq. (18) becomes ev_5 .

PROOF. To prove stability results at W_0 for the vector $P(t) = (V(t), V_a(t), V_s(t), H_a(t), H_r(t))$ we calculate the Jacobian matrix J at the origin W_0 :

$$J = \begin{pmatrix} -k-m+b & 0 & 0 & 0 & 0 \\ q & -q-m & -q & 0 & 0 \\ b-k & 0 & -m & \frac{-V_0 b \tau_2}{H+A} & 0 \\ 0 & \frac{\tau_3 H}{H+A} & 0 & -r_1 & 0 \\ 0 & 0 & 0 & r_1 & -r_2 \end{pmatrix} \quad (21)$$

We consider first the case C1 with $k+m-b > 0$. (The case C2 with $k=0$, $m=b$ follows directly from the fact that the system is then four-dimensional ($V(t)$ is constant) and the corresponding Jacobian matrix consists of the 4×4 block in the lower right corner of J).

Two obvious eigenvalues are $ev_1 = -k-m+b$ and $ev_2 = -r_2$. Elementary but long calculations show that the three other eigenvalues (ev_3 , ev_4 , ev_5) are the roots of the cubic equation (in the unknown x):

$$H(x) \stackrel{\text{def.}}{=} (m+x)(m+q+x)(r_1+x) = R_0 m(m+q)r_1 = \frac{kV_0 b \tau_2 q \tau_1^2 \tau_3}{(k+m-b)H} \quad (22)$$

By expanding $H(x)$ we obtain

$$x^3 + rx^2 + sx + t = 0 \quad (23)$$

where r, s, t are given in Eqs. (10)–(12). Whether there is one or three real roots, the closed-form expressions for the roots ev_3 , ev_4 , and ev_5 are

$$ev_3 = 2 \left(-\frac{p^*3}{27} \right)^{1/6} \cos \left(\frac{1}{3} \times \arccos \left(\frac{-q^*}{2} \left(-\frac{p^*3}{27} \right)^{-1/2} \right) + \frac{4\pi}{3} \right) - \frac{r}{3} \quad (24)$$

$$ev_4 = 2 \left(-\frac{p^*3}{27} \right)^{1/6} \cos \left(\frac{1}{3} \times \arccos \left(\frac{-q^*}{2} \left(-\frac{p^*3}{27} \right)^{-1/2} \right) + \frac{2\pi}{3} \right) - \frac{r}{3} \quad (25)$$

$$ev_5 = 2 \left(-\frac{p^*3}{27} \right)^{1/6} \cos \left(\frac{1}{3} \times \arccos \left(\frac{-q^*}{2} \left(-\frac{p^*3}{27} \right)^{-1/2} \right) \right) - \frac{r}{3} \quad (26)$$

where p^* , q^* are given in Eqs. (13)–(14). The cosine and arccosine function are defined in the complex domain when the real argument

$$W \stackrel{\text{def.}}{=} \frac{-q^*}{2} \left(-\frac{p^*3}{27} \right)^{-1/2} \quad (27)$$

of the acosine function has an absolute value larger than 1.

The proof will now proceed in three steps. We will first show that ev_5 has the largest real part among the three roots and is real (Step 1). Then we will show that if $R_0 > 1$ then $ev_5 > 0$ and if $R_0 < 1$ then $ev_5 < 0$. (Step 2). Finally we will obtain the results on the convergence rates by considering the basis in which the matrix J is in diagonal form (Step 3).

Step 1

We define for any real Z the three functions

$$u_3(Z) \stackrel{\text{def.}}{=} \cos\left(\frac{\arccos(Z)}{3} + 4\pi/3\right) \quad (28)$$

$$u_4(Z) \stackrel{\text{def.}}{=} \cos\left(\frac{\arccos(Z)}{3} + 2\pi/3\right) \quad (29)$$

$$u_5(Z) \stackrel{\text{def.}}{=} \cos\left(\frac{\arccos(Z)}{3}\right) \quad (30)$$

whose real parts are plotted in Figure 2 (together with the cubic $Z(u) = 4u^3 - 3u$ that will be used below). The fact that $\text{Re}[u_4(Z)] \leq \text{Re}[u_3(Z)] \leq \text{Re}[u_5(Z)]$ and $p^* < 0$ implies that

$$\text{Re}(ev_4) \leq \text{Re}(ev_3) \leq \text{Re}(ev_5) \quad (31)$$

For $Z \geq -1$ then $u_5(Z) = \text{Re}[u_5(Z)]$ (i.e. $u_5(Z)$ is real) and $u_5(Z)$ is then a real increasing function of Z for $Z \geq -1$. In addition, if $Z < -1$ then $u_5(Z)$ is pure imaginary.

Given that

$$ev_5 = 2\left(-\frac{p^*3}{27}\right)^{1/6} u_5(W) - r/3 \quad (32)$$

we see that ev_5 is a real increasing function of W if $W \geq -1$. We will now prove that $W \geq -1$ by considering W as a function $W(r,s,t)$ of the three parameters r, s, and t. For any fixed r, s (i.e. any fixed m, q, r_1) $W(r,s,t)$ is a decreasing affine function of t ($W(r,s,t) = \alpha t + \beta$, $\alpha < 0$). $W(r,s,t)$ reaches a minimum $W_m = W(r,s, m(m+q)r_1)$ for $t = m(m+q)r_1$ (when $R_0 = 0$). However in this case the three roots of Eq. (22) are $-m$, $-m-q$, and $-r_1$. Therefore necessarily $W_m \geq -1$ since otherwise ev_5 would be

imaginary. This proves that $W \geq -1$ which implies that $u_5(W)$ and ev_5 are real.

We define the right-hand side of Eq.(22) as

$$R^* = \frac{kV_c b \tau_2 q \tau_1^2 \tau_3}{(k+m-b)H} \quad (33)$$

Step 2

We now assume that $R_0 > 1$ (which is equivalent to $R^* > m(m+q)r_1$). Figure 3a depicts a typical example of the cubic $H(x)$ ¹. The function cancels out at $-m$, $-m-q$, $-r_1$ and the equation $H(x)=R^*$ has one positive root (ev_5) as well as two complex roots since the horizontal line at R^* intersects the function $H(x)$ only once. (There would be three real roots for R^* small enough). The fact that there is a positive root can also be seen from the fact that for $x > 0$ $H(x)$ is an increasing function of x that is equal to $m(m+q)r_1$ at $x=0$. The equation $H(x)=R^*$ then necessarily has a single positive root that must be ev_5 since ev_5 is a real root that is larger than the real parts of ev_3 and ev_4 (see (31)).

We next assume that $R_0 < 1$ (i.e. $R^* < m(m+q)r_1$). Figure 3b depicts in this case a typical function $H(x)$. If R_c is the value at which a horizontal line is tangent to $H(x)$ then there are three negative roots (ev_4, ev_3, ev_5) if $R^* < R_c$ (e.g. at $R^*=R^*(1)$) and two complex and one negative root if $m(m+q)r_1 > R^* > R_c$ (e.g. at $R^*=R^*(2)$).

We will now prove analytically that $ev_5 < 0$ by showing that the right-hand side of (32) reaches a maximum of 0 when W is equal to its largest possible value $W(r,s,0)$. We will do this by proving that

$$u_5(W(r,s,0)) = \frac{r/3}{2 \left(-\frac{p^{*3}}{27} \right)^{1/6}} \quad (34)$$

The proof will hinge on the fact that the polynomial $Z(u)=4u^3-3u$ has (See Figure 2):

¹ In this Figure we have $r_1 < m$ which is usually the case without intervention: the life expectancy ($1/m$) of the tsetse fly is of the order of one or two months whereas the time spent in the asymptomatic stage ($1/r_1$) is several months to several years. The detection of infected individuals can however bring r_1 above m .

- a. $u_5(Z)$ as its inverse for $u \in (0.5, +\infty)$; on this interval $Z > -1$ & $u_5(Z) = \text{Re}[u_5(Z)]$.
 b. $u_3(Z)$ as its inverse for $u \in (-0.5, 0.5)$; on this interval $-1 < Z < 1$ & $u_3(Z) = \text{Re}[u_3(Z)]$.
 b. $u_4(Z)$ as its inverse for $u \in (-\infty, -0.5)$; on this interval $Z < -1$ & $u_4(Z) = \text{Re}[u_4(Z)]$.

A direct substitution shows that the quantity $u^* = \frac{r/3}{2\left(-\frac{p^*3}{27}\right)^{1/6}}$ satisfies the equation

$Z(u^*) = 4u^{*3} - 3u^* = W(r,s,0)$. Since $W(r,s,0) > -1$ the quantity u^* is necessarily equal to $u_5(W(r,s,0))$. Eq. (34) holds and therefore ev_5 reaches a maximum of 0 when $t=0$, i.e., when $R_0=1$. Because ev_5 is an increasing function of W this proves that $ev_5 < 0$ when $R_0 < 1$ and that all eigenvalues have negative real parts (see (31)).

Step 3

When $R_0 < 1$ the linear approximation at the origin of the system of differential equations in the variable $W(t) = (V(t)-V_0, V_a(t), V_s(t)-V_0, H_a(t), H_r(t))$ can be written as

$$\frac{dW(t)}{dt} = PDP^{-1}W(t) \quad (35)$$

where D is a diagonal matrix with the eigenvalues $ev_1, ev_2, ev_3, ev_4, ev_5$ on the diagonal and P is a matrix with the corresponding eigenvectors in its columns. If we define the functions

$$E_1(d) = \frac{(r_1+d)(r_2+d)(H+A)}{\tau_3 H r_1} \quad (36)$$

$$E_2(d) = \frac{-V_0 b \tau_2 (r_2+d)}{(m+d)(H+A)r_1} \quad (37)$$

$$E_3(d) = \frac{(r_2+d)}{r_1} \quad (38)$$

then the matrix P is

$$P = \begin{pmatrix} 1 & 0 & 0 & 0 & 0 \\ 0 & 0 & E_1(ev_3) & E_1(ev_4) & E_1(ev_5) \\ 1 & 0 & E_2(ev_3) & E_2(ev_4) & E_2(ev_5) \\ 0 & 0 & E_3(ev_3) & E_3(ev_4) & E_3(ev_5) \\ 0 & 1 & 1 & 1 & 1 \end{pmatrix} \quad (39)$$

If P_i ($i=1,2,3,4,5$) denotes the i -th column of P , then

$$W(t) = \sum_{k=1}^5 c_k P_k e^{ev_k} \quad (40)$$

where the five scalars c_k ($k=1,2,\dots,5$) depend on initial conditions (and are assumed $\neq 0$). Eq. (40) shows that $V(t)-V_0$ (the first component of $W(t)$) approaches 0 at a rate $ev_1 = -k-m+b$ (which is not surprising in view of Eq. (6)). Because only the last three entries of the second row of P are non-zero, the second component $V_a(t)$ of $W(t)$ converges to 0 at a rate equal to $\max(\operatorname{Re}[ev_3], \operatorname{Re}[ev_4], ev_5) = ev_5$. Similarly, $V_s(t)-V_0$ converges to 0 at a rate equal to $\max(-k-m+b, \operatorname{Re}[ev_3], \operatorname{Re}[ev_4], ev_5) = \max[-k-m+b, ev_5]$. The results of Eqs. (18)-(20) follow in a similar fashion.

4. Discussion

4.1. Basic reproduction number or rate of extinction?

The quantity ev_5 of Eq. (15) plays a central role in the convergence rates of the five variables $V(t)$, $V_a(t)$, $V_s(t)$, $H_a(t)$ and $H_r(t)$. In particular when $R_0 < 1$ then ev_5 is the extinction rate of the actively infected populations $V_a(t)$ and $H_a(t)$ (Eq. (17) and Eq. (19)).

In previous work we focused on R_0 as a stability criterion of the origin, i.e. when investigating control strategies we adopted the classical approach which consists in studying parameters values for which R_0 was either above 1 or below 1. (Artzrouni and Gouteux, 1996a,b). However bringing R_0 just below 1 may be of little value since the halving time of the epidemic can then be very long. To illustrate this, consider the following set of realistic "baseline" parameter values taken from Artzrouni and Gouteux (1996a,b) (recall that the time unit is 3 days; if we assume that every month has 30 days then for example a 25-day incubation period translates into a rate $q = 3/25 = 0.12$).

<u>Parameter</u>	<u>Value</u>
V_c	5,000
H	300
τ_1	0.1
τ_2	0.1
τ_3	0.62
q	0.12 (incub. = 25 days)
r_1	0.0075 (asympt. stage = 13.33 months)
b	1/15
m	1/15 (life expect. = 1.5 months)
V_0	5,000

Table 1: Baseline values for parameters

With these parameter values, $R_0 = 0.886$, $ev_5 = -7.539 \cdot 10^{-4}$ and the halving time expressed in months is $HT = \frac{0.1 \ln(0.5)}{ev_5} \approx 92$ months. Even though R_0 is well below

1, it takes more than seven years for the infected population to be cut in half. If however the death rate m could be increased to 1/10 (through trapping or any other control method that increases the vector mortality) then R_0 drops to 0.273; V_0 , the equilibrium vector population, drops to 2,727, and the corresponding halving time HT is (still) over one year (13 months).

If τ_2 and r_1 of Table 1 are taken equal to 0.068 and 0.00525 (with other parameters kept unchanged) then $R_0 = 0.860$ and $ev_5 = -6.705 \cdot 10^{-4}$ with a corresponding halving time of 103 months. This example shows that depending on how the parameters are modified, a decrease in the basic reproduction number – which may seem a desirable result – can actually increase the halving time (by almost a year in the present example). The paradox of a decrease in R_0 bringing about a more protracted epidemic confirms that simply lowering R_0 may not be the desirable outcome of a control strategy.

Although R_0 is biologically meaningful, the parameter ev_5 (or the halving time HT) is an epidemiologically more useful criterion for extinction since it incorporates the rate at which the disease dies out¹. This is particularly significant in the study of optimal control strategies since an important factor is *how long* a given strategy must be used to obtain a given result (for example a 90% decrease of the infected population).

4.2. Control strategies

We will now briefly explore the implications of these results for the study of optimal control strategies. These strategies involve vector control (which increase the vector mortality m) and the detection of infected individuals (which increases r_1). All other parameters are kept constant (Artzrouni and Gouteux, 1996b).

¹ In the past the computational simplicity of R_0 was an advantage, but today with algebraic manipulation softwares such as Mathematica[®] and Mathcad[®], the relative complexity of the closed-form expression for ev_5 is immaterial.

Although the expression (15) for ev_5 is a complicated function of r_1 and m , the relationship between ev_5 and these two parameters appears clearly when one considers ev_5 as the largest root of $H(x)=R^*$ (Figures 2a,b). Indeed, if m increases with fixed r_1 , then the intersection of $H(x)$ with the vertical axis moves upward, and ev_5 decreases without ever going below $-r_1$: no matter how much vector mortality is increased, the rate of extinction ev_5 cannot be brought under $-r_1$. Hence in endemic situations in which infected persons may stay several years in the asymptomatic stage, the halving time will also be several years, regardless of any attempts at vector control. Similarly if r_1 is made to increase through aggressive screening, then ev_5 cannot drop below $-m$.

These relationships are explored more precisely in Figure 4 which represents ev_5 as a function of r_1 and m , for $0.0075 < r_1 < 0.2$ and $1/15 < m < 0.4$. (The lower bounds thus correspond to the baseline values of Table 1). The figure clearly shows how the "steepest descent" on the surface will depend on the initial ("pre-intervention") level of r_1 and m . If the initial values are those of Table 1, we are at the top right corner of the graph (point A) and the steepest decrease in ev_5 is obtained by increasing both r_1 and m in order to stay in the "valley of steepest descent". If $m=0.23$ (about the middle of the interval, with the same value of r_1 : point B) then it is apparent that further increasing m leaves ev_5 virtually unchanged. The steepest descent is obtained by increasing r_1 alone. (This increase could go all the way to the valley in which both parameters should then increase in tandem). Similarly, if r_1 is about 0.10 (point C) then m should be increased first and then both variables should increase together.

5. Conclusion

There is evidence to suggest that density-dependent phenomena play an important role in the population dynamics of tsetse flies. Our goal here was to contribute to our understanding of these phenomena by proposing a model of the spread of sleeping sickness that incorporates a regulating migratory mechanism. We plan in the future to use available field data to assess in greater detail the validity of the regulating term $k(V_C - V(t))$. In particular we will need to obtain rough estimates of the parameter k that measures the strength of the feedback.

We also studied in detail the rate of extinction ev_5 and argued that this rate is a better measure of the potential spread of the disease than R_0 because ev_5 incorporates the rate at which the disease will die out. The well-documented persistence of sleeping-sickness foci in various areas of Africa could thus be explained by the transmission's slow dynamics which we plan to investigate empirically through the rate of extinction ev_5 . [We note that if ev_5 is just below 0, then as discussed the convergence to extinction will be slow. Although we have not dwelt on the case of epidemic flare-up, it is also the case that an ev_5 just above 0 will give rise to a very slowly expanding infection].

Models that incorporate the reality of open and fluctuating vector populations and that include a measure of the duration of the epidemic should contribute to a better understanding of a serious disease that still affects large areas of Africa.

REFERENCES

Artzrouni M, Gouteux JP (1996a) A compartmental model of vector-borne diseases: Application to sleeping sickness in central Africa. *Journal of Biological Systems*, 4,4: 459-477.

Artzrouni M, Gouteux JP (1996b) Control Strategies for Sleeping Sickness in central Africa: A Model-based Approach. *Tropical Medicine and International Health*, 1,6: 753-764.

Authie E., Cuisance D., Force-Barge P. *et al.* (1991) Some new prospects in epidemiology and the fight against human african trypanosomiasis. ICASEP 1. Congress; Valencia (Spain). *Research and Reviews in Parasitology*, 51 (1-4): 29-46.

Cattand P. (1994) Trypanosomiase humaine africaine: situation épidémiologique actuelle, une recrudescence alarmante de la maladie. *Bull. Soc. Path. exo.*, 5/5bis : 307-310.

Dransfield R.D., Brightwell R. (1989) Problems of field testing theoretical models: A case study. *Ann. Soc. belge Méd. Trop.*, 69 : Suppl. 1, 147-154.

Frezil JL, Coulm J. (1976) Etude épidémiologique du foyer réurgent de Comba. 11ème Conf. Tech. OCEAC, Yaoundé, 25-27 mars 1976, 218-227.

Frezil JL, Cuisance D (1994) Trypanosomiasis, diseases with future: prospects and uncertainty. *Bull. Soc. Path. Ex.* , 87: 391-393.

Gouteux JP, Artzrouni M. (1996) Faut-il ou non un contrôle des vecteurs dans la lutte contre la maladie du sommeil? *Bull. Soc. Path. Ex.* , 89: 299-305.

Gouteux, JP., Kounda-Gboumi JC, Noutoua, L. *et al.* (1993) Man-fly contact in the Gambian trypanosomiasis focus of Nola-Bilolo (Central African Republic). *Trop. Med. Parasitol.* 44 (3): 213-218.

Hargrove J.W. (1981) Discrepancies between estimates of tsetse fly populations using mark-recapture and removal trapping techniques. *J. Applied Ecology*, 18: 737-748.

Jordan A.M. (1976) Tsetse flies as vectors of trypanosomes. *Vet. Parasit.*, 2: 143-152.

Kageruka P (1989) Réservoir animal de *Trypanosoma (Trypanozoon) brucei gambiense* en Afrique Centrale. *Annales de la Société Belge de Médecine Tropicale* 69 (suppl. 1), 155-163.

Lebreton J.D., Millier C. (1982) Modèles dynamiques déterministes définis par des équations différentielles, pp 13-57 in: *Modèles dynamiques déterministes en biologie*. Masson, Paris.

Le Ray D (1989) Vectors susceptibility to African trypanosomes. *Annales de la Société Belge de Médecine Tropicale* 69 (suppl. 1), 165-171.

Noireau F, Gouteux JP, Toudic A, Samba F, Frezil JL (1986) Importance épidémiologique du réservoir animal *Trypanosoma brucei gambiense* au Congo I. Prévalence des trypanosomoses animales dans les foyers de maladie du sommeil. *Tropical Medicine and Parasitology* 37, 393-398.

Rogers DJ (1988a) A general model for the African trypanosomiases. *Parasitology* 97, 193-212.

Rogers DJ (1988b) The dynamics of vector-transmitted diseases in human communities. *Philosophical Transactions of the Royal Society of London Series B*, 321, 513-539.

Rogers DJ (1989) The development of analytical models for human trypanosomiasis. *Annales de la Société Belge de Médecine Tropicale* 69 (suppl. 1) 73-88.

Rogers D.J., Randolph S., Kuzoe F.A.S. (1984) Local variation in the population dynamics of *Glossina palpalis palpalis* (Robineau-Desvoidy) (Diptera: Glossinidae). 1. Natural population regulation. *Bull. Ent. Res.* 74: 403-423.

Turner D.A., Brightwell R. (1986) An evaluation of sequential aerial spraying operation against *Glossina pallidipes* Austen (Diptera: Glossinidae) in the Lambwe Valley of Kenya: aspects of post-spray recovery and evidence of natural population regulation. *Bull. Ent. Res.* 76 : 331-349

Zillmann U., Mehlitz D., Sachs R. (1984) Identity of Trypanozoon stocks isolated from man and a domestic dog in Liberia. *Tropenmed. Parasitol.*, 35 : 105-108.

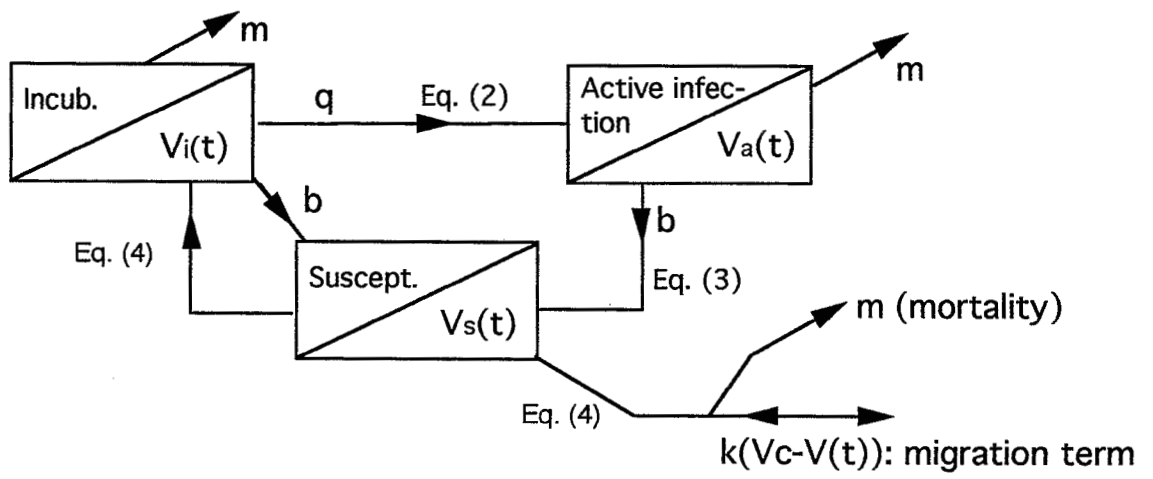

Vectors

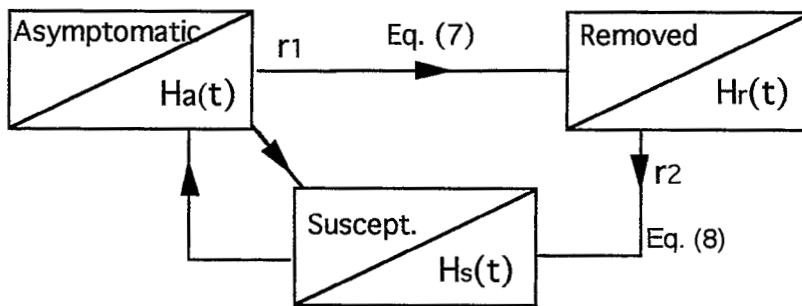

Humans

Figure 1: Compartments of the model

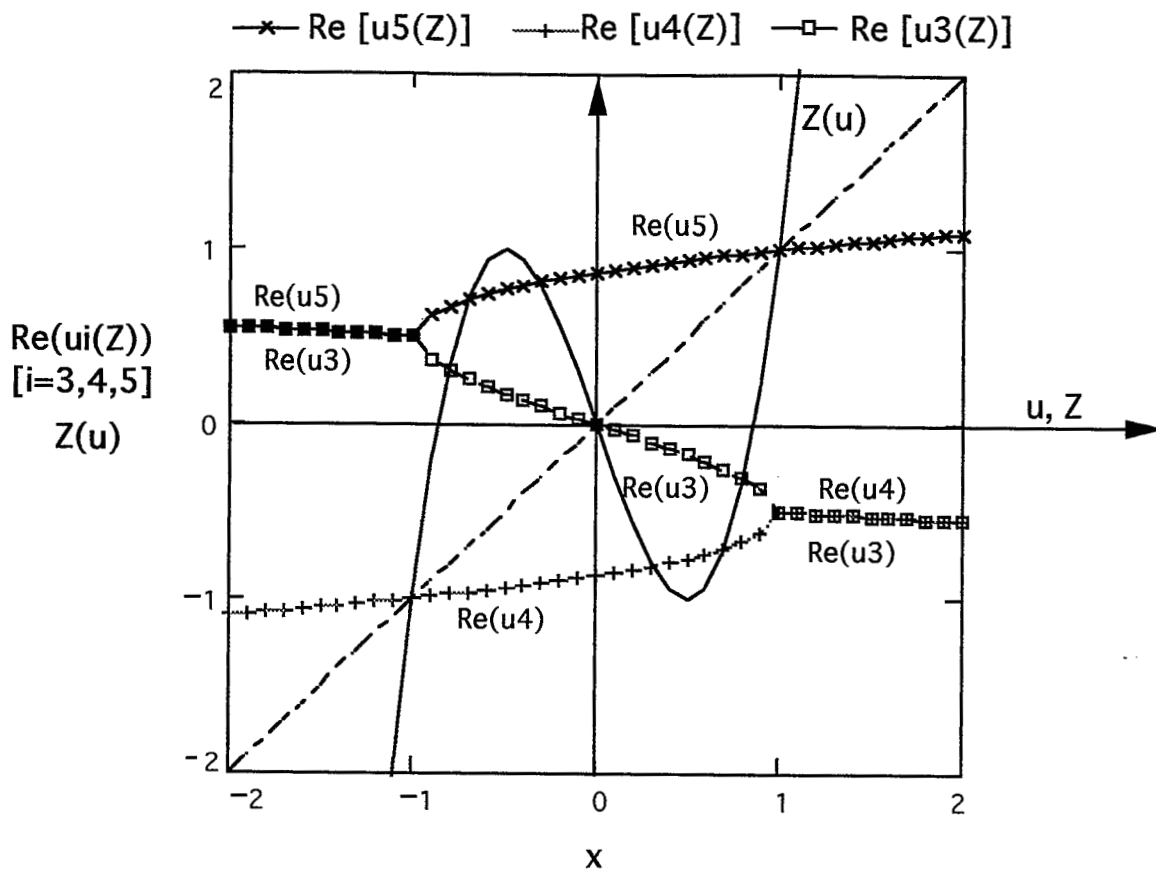

Figure 2: Polynomial $Z(u)$ and functions $\text{Re}(u_i(Z))$; $i=3,4,5$.

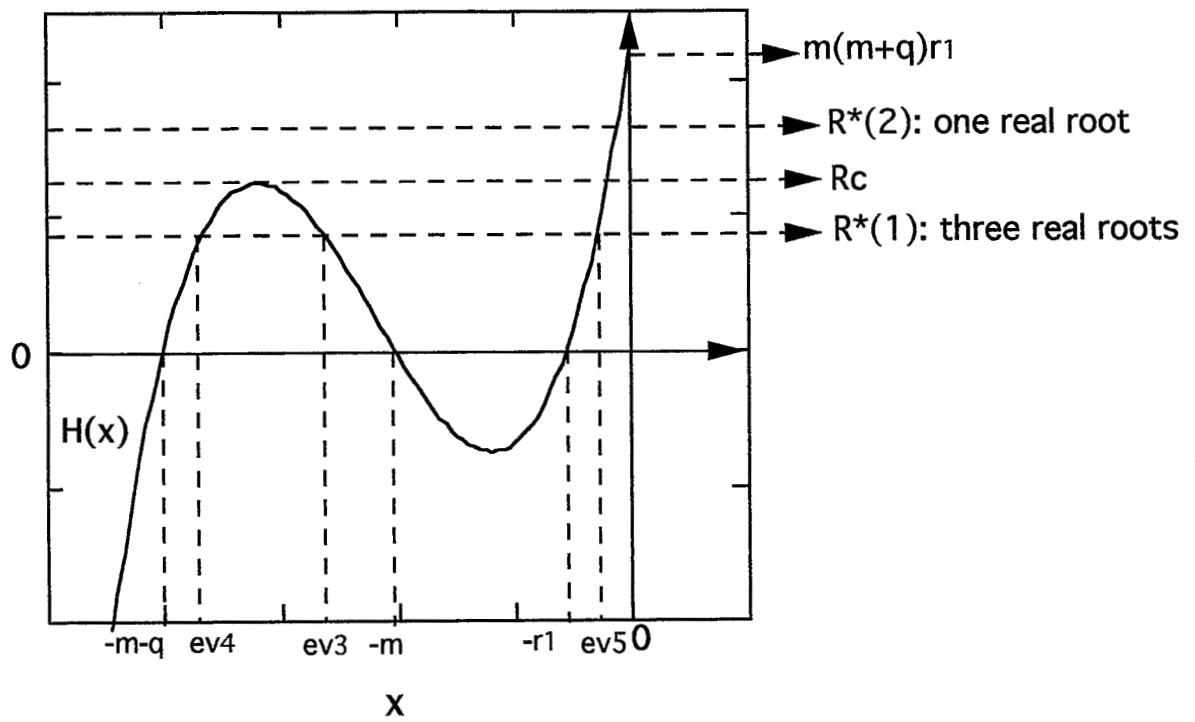

Figure 3b: Cubic $H(x)$ of Eq. (22) ($R_0 < 1$, i.e. $R^* < m(m+q)r_1$).

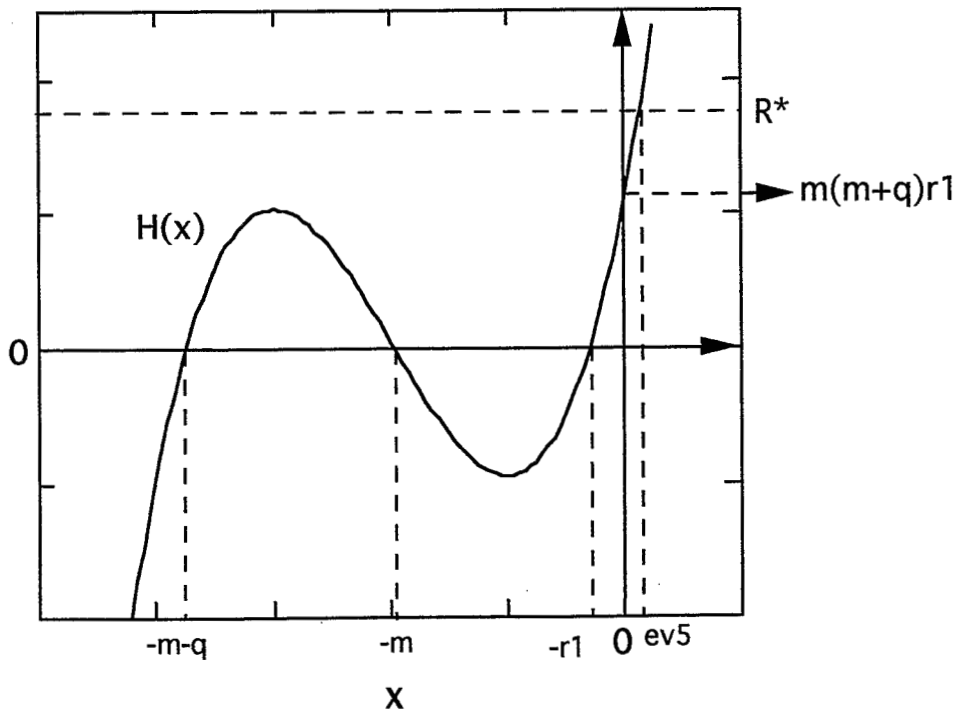

Figure 3a: Cubic $H(x)$ of Eq. (22) ($R_0 > 1$, i.e. $R^* > m(m+q)r_1$).

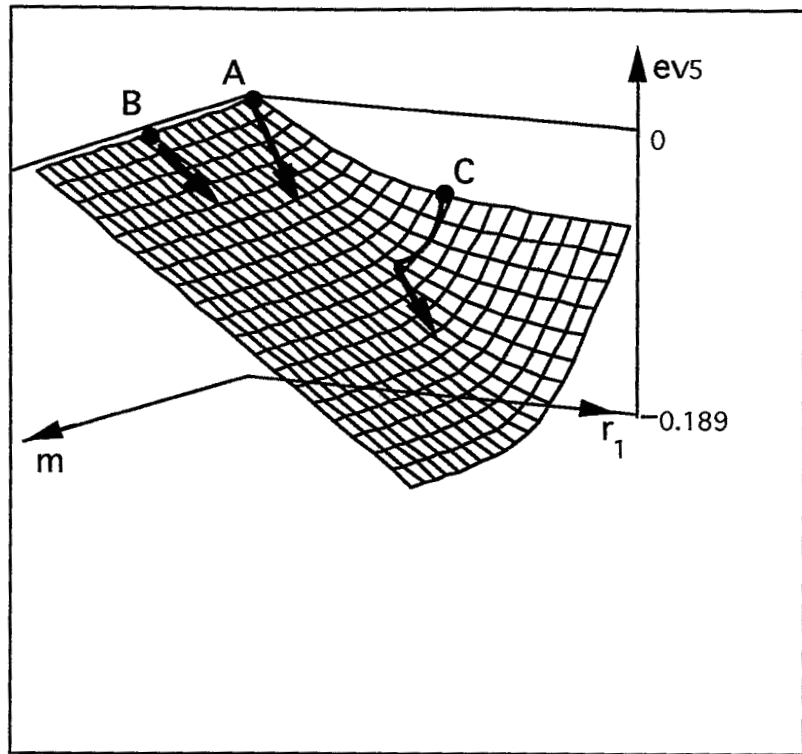
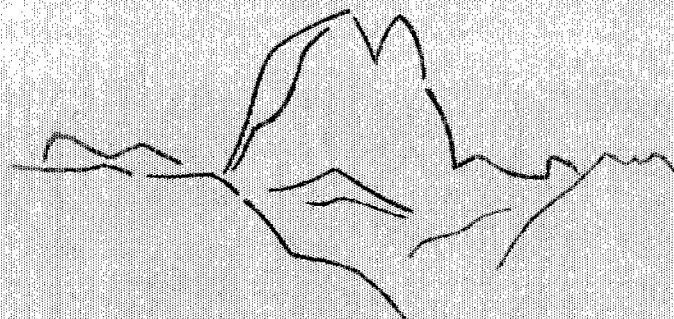
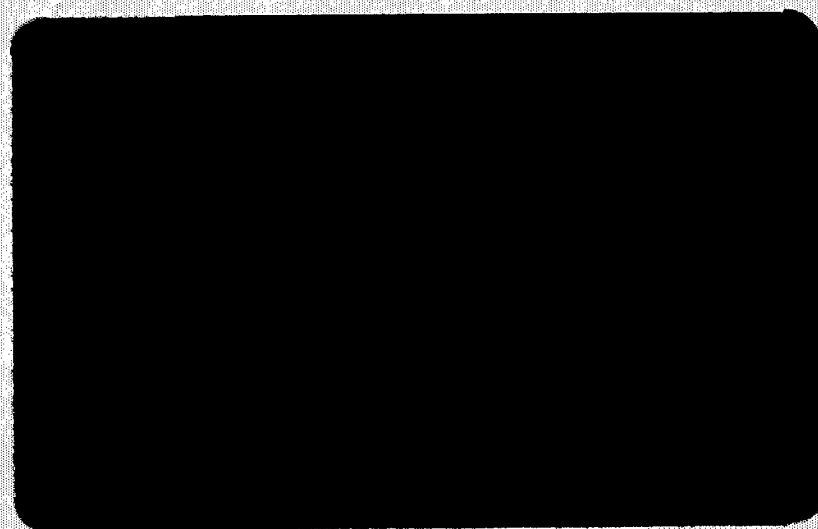

Figure 4: Value of $ev5$ as a function of r_1 and m .



**LABORATOIRE DE MATHÉMATIQUES APPLIQUÉES
UPRES A 5033**



**UNIVERSITÉ DE PAU ET DES PAYS DE L'ADOUR
ET
CENTRE NATIONAL DE LA RECHERCHE SCIENTIFIQUE**