

TERMS OF BINDING

Published by
LOT
Janskerkhof
3512 BL Utrecht University
The Netherlands

phone: +31 30 253 6006
fax: +31 30 253 6000
email: lot@let.uu.nl
<http://www.lot.let.uu.nl>

ISBN-10: 90-78328-17-7
ISBN-13: 978-90-78328-17-9
NUR 632

Copyright © 2006: Anca Sevcenco. All rights reserved

TERMS OF BINDING

VOORWAARDEN VOOR BINDING

PROEFSCHRIFT

ter verkrijging van de graad van doctor
aan de Universiteit Utrecht
op gezag van de Rector Magnificus, Prof.Dr. W.H. Gispen
ingevolge het besluit van het College voor Promoties
in het openbaar te verdedigen
op maandag 4 december 2006
des middags te 12:45 uur

door

Anca Sevcenco

geboren op 24 mei 1971 te Boekarest, Roemenië

PROMOTORES:

Prof.dr. M.B.H. Everaert

Prof.dr. E.J. Reuland

TABLE OF CONTENTS

ACKNOWLEDGMENTS	9
INTRODUCTION	11
CHAPTER 1	
Basic facts about binding	13
1. Theoretical preliminary	13
1.1. Binding Theory: from the Government and Binding framework to the Minimalist Program	13
1.2. Coreference and bound variable readings	23
1.3. A few introductory remarks on reflexivization strategies	26
2. SE-reflexives.....	27
2.1. <i>Se</i>	27
2.2. <i>Sine</i>	37
2.2.1. Non-local <i>sine</i>	44
3. Bound (and emphatic) pronouns	50
4. Emphatics: <i>sine însuși, el însuși</i>	52
5. Concluding remarks	59
CHAPTER 2	
Clause structure	61
1. Preliminary	61
2. The structure of Romanian clauses	62
2.1. Evidence to support the VSO order	66
2.1.1. Distributional evidence	66
2.1.2. Interpretational evidence	71
2.2. A stumbling block	74
3. Summary	78
4. Consequences	78
CHAPTER 3	
Non-local binding and the Blocking Effect	83
1. Levels of dependency encoding: from syntax via semantics to discourse ..	83
1.1. Introductory remarks	83
1.2. The notion of “non-local anaphor”	87

1.2.1. Logophoric pronouns	88
1.2.2. Logophoric anaphors	91
1.2.3. The distinction between logophors and NLA's	93
1.3. Interim conclusions (i)	95
2. Binding within the Minimalist Program (Chomsky 1995 and subsequent work)	95
2.1. Levels of representation (internal versus interface levels)	95
2.2. Efficient computation: the five cycle versus the one cycle derivation	96
2.3. Where does binding apply?	97
2.3.1. Binding holds at the C-I interface	97
2.3.2. Binding has a syntactic residue	102
3. Brief survey of an economic theory on the encoding of anaphoric dependencies	104
3.1. Syntactically encoded anaphoric dependencies	104
3.1. Binding at the C - I interface	106
3.2. Covaluation in discourse	106
4. Cross linguistic core properties of NLA	108
4.1. Subject orientation	108
4.2. C-command	113
4.3. Sloppy and strict readings under VP-ellipsis	114
5. Peculiarities of Romanian non-local anaphors	122
6. Conclusions	129
CHAPTER 4	
Analysis of the non local binding phenomenon.....	131
1. Introduction	131
2. The morpho-syntactic features of <i>sine</i>	132
2.1. Person specification	132
2.2. Number specification	132
2.3. Morphological decomposition	135
2.4. Idiolectal variation with non-local binding	137
3. The mechanism behind long distance binding	137
3.1. Katada 1991	138
3.2. Koopman & Sportiche 1989	139
3.3. Chierchia 1989	139
4. The proposal of this dissertation	141

4.1.	Necessary assumptions	141
4.2.	The analysis at work	144
4.2.1.	Deriving descriptive generalization 1	148
4.2.2.	Deriving descriptive generalization 2	152
4.2.2.1.	Hypothesis	152
4.2.2.2.	Understanding the notion of defective Probe	153
4.2.3.	The operator gets the default value	155
4.2.3.1.	The case of ECM with defective T	155
4.2.3.2.	The case of ECM with adjectival predicate	156
4.3.	Deriving descriptive generalization 3	156
4.3.1.	Chinese and Romanian blocking patterns: a comparison	158
4.3.2.	An outline of a BE analysis for Romanian	160
5.	Further remarks.....	162
5.1.	Long distance binding and successive cyclic movement	162
5.2.	Islands	164
6.	Conclusions	168
	Concluding Remarks.....	169
	Appendix	
	A Magnitude Estimation experiment on non-local binding	175
1.	Introduction. The method.	175
2.	The questionnaire	176
2.	Results and their interpretation	182

ACKNOWLEDGMENTS

Many people have crossed my path in the three years that I spent at UiL OTS, Utrecht University, where I was enrolled in a Ph.D program. I will take this opportunity to express my gratitude for the different ways they contributed to the making of this dissertation.

My first thanks go to my supervisors, Martin Everaert and Eric Reuland or Eric Reuland and Martin Everaert, an unordered pair; it does not matter who comes first. Our frequent meetings helped me come up with ideas and shape them up (of course, if the respective ideas proved to be worth going through the shaping up process at all!). Martin and Eric taught me to structure my (linguistic) thinking and to be thorough and scientific in my linguistic pursuits. A nice complementation to my supervisors came from Kriszta Szendrői, my postdoc advisor. She was always ready to provide me with insightful remarks and comments on both the theoretical and experimental side of my work. Moreover, it was quite nice to have her to talk to, especially for two reasons. First, we come from almost the same part of the world. Second, she knew from the very beginning that Romanian is not a Slavic language. Of course, my Romanian professor, Alexandra Cornilescu, must not be forgotten. She introduced me to formal linguistics and taught me good English.

For good company as well as for talking shop (mostly in Lokaal 9, but not only), I would like to thank to an entire host of UiL OTS linguists: Anna Asbury, Fabian Battaglini, Ivana Brasileiro, Matteo Capelletti, Alexis Dimitriadis, Jakub Dotlacil, Berit Gehrke, Nino Grillo, Annemarie Kerkhoff, Cem Keskin, Olga Khomisevitch, Anja Kijak, Marieke Kolkman, Marjo van Koppen, Huib Kranendonk, Bert Le Bruyn, Shakuntala Mahanta, Marijana Marelj, Øystein Nilsen, Dalan Perangin-angin, Min Que, Gyuri Rakosi, Mirjam Rigterink, Irina Rogozhina, Oren Sadeh-Leicht, Rianne Schippers, Natasha Slioussar, Giorgos Spathas, Robi Tedeschi, Christina Unger, Nada Vasic, Mario van de Visser, Evi Vlachou and Peter Zubkov.

Some of them - Øystein Nilsen, Mirjam Rigterink, Gyuri Rakosi, Nino Grillo and Giorgos Spathas – were particularly helpful with discussing, reading and commenting on the earlier versions of my chapters. I commiserate with them a bit, because I am well aware that I am not always a clear writer, speaker, listener.

Annemarie Kerkhoff and Mirjam Rigterink deserve special additional thanks as well for providing me with the Dutch summary for the dissertation. Moreover, I cannot forget that Annemarie was the first friendly face I met when I came to Utrecht and Mirjam cooked my first stamppot dish. Oren Sadeh-Leicht must also join the ranks, not only for being a very nice officemate (in my Trans 10 days), but also for doing the statistics for my magnitude estimation experiment.

There are a couple of people that are not connected to the Netherlands, but whom I must include in these acknowledgments for different reasons. I am grateful to my friend, Jack Friedman, for encouraging me to stick my neck out and give a try to academic life outside my home country. In this respect he is responsible (and also to blame for) my stay at Utrecht University. I am also grateful to my Romanian friends, Nadina Vişan and Ruxi Drăgan, for being so chatty that there is no need for me to speak at all (quite relaxing!).

To come back to the Netherlands, I would like to thank a couple of special friends that have helped in different ways bridge the gap between my life in Romania and Holland: Anna, Nino, Berit, Robi, Gyuri and Giorgos.

My last thanks go to Master Yoda, whose portrait hangs on the first floor of Achter de Dom 24, the alarm system in the selfsame building, which I innocently and unnecessarily triggered off a couple of times (yes, unnecessarily, but the sharp, shrill sound of it helped with keeping my mind clear and focused) and the Meldkamer boys, who were here day and night for me. All I had to do was call them up and let them know I would be in my office until 23:00, 24:00, 2 a.m., etc. Their prompt answer was always “yes, we are here for you and we never tire (of you and our job)”. How is that for unselfish?

No, don't think I have forgotten my parents, I have dedicated this book to them.

INTRODUCTION

The present dissertation is set in the minimalist framework outlined in Chomsky (2001, 2004, 2005) and investigates the proposal that binding theory has a syntactic residue Reuland (2001, 2005) in the sense that it attempts to support this point and explore its consequences, drawing mainly on data from Romanian. In a nutshell, I will argue in favor of extending the syntactic residue of binding so as to include A' dependencies. The dissertation is organized as follows.

Chapter 1 makes a presentation of the Romanian anaphoric system. It concentrates on the characterization of Romanian anaphoric forms in terms of their morpho-syntactic features (i.e. ϕ features and other relevant features such as [\pm reflexive marker] and [\pm R] (Reinhart & Reuland 1993). The morpho-syntactic make-up of an anaphoric form defines its intrinsic properties. Those intrinsic properties, in their turn, will determine what kind of interpretive dependency the respective anaphoric form enters. Namely, they will determine whether an anaphor relates to its antecedent as a result of a syntactic, semantic or discourse operations.

Chapter 2 reviews the literature on Romanian clause structure in order to motivate the syntactic representations that will be used in my analysis of non-local binding.

Chapter 3 introduces and defines the notion of non-local anaphor. In this chapter, I argue that non-local anaphors link up to their antecedents as the result of an A'-dependency having been established in syntax. I discuss the properties that set non-local anaphors apart as a class, i.e. subject-orientation, c-command, sloppy reading under VP ellipsis. I argue that these properties constitute evidence to believe that non-local anaphors are involved in a structural, syntactic dependency. I use sensitivity to island effects and to relativized minimality effects to test the nature of this dependency. The conclusion will be that it is an A'-dependency. The chapter also gives an update of the state of binding theory in the minimalist program. It makes a short presentation of how to integrate binding phenomena in an economic theory of anaphoric dependency encoding (Reuland 2001, 2005). This theory will be the framework of my analysis.

Chapter 4 gives the technical details on how to capture non-local binding in terms of an A'-dependency. The morpho-syntactic make-up of the

non-local anaphor under scrutiny here, a mixture between a reflexive pronoun and an operator bound pronominal expression (Enç 1989, Koopman & Sportiche 1989, Varlokosta & Hornstein 1993), motivates why it has to enter an A' dependency. The chapter explains the intervention effects that affect non-local binding (i.e. relativized minimality, the Blocking Effect) and also includes a discussion of islands and non-local binding.

Chapter 5 makes a couple of concluding remarks and highlights issues for further research.

The **Appendix** reports the results of a Magnitude Estimation experiment on the acceptability of non-local binding with Romanian native speakers. This experimental task has been undertaken because there is a split among native speakers with respect to the acceptability of non-local binding sentences (i.e. some speakers accept it, other do not). The statistical result points to two conclusions: (i) there is a group of speakers who accept non-local binding and (ii) within that particular group, local and non-local binding sentences pattern together in contrast to sentences where the Blocking Effect is at work (this latter type has been judged as unacceptable).

CHAPTER 1

Basic facts about binding

1. *Theoretical preliminary*

1.1. **Binding Theory: from the Government and Binding framework to the Minimalist Program**

Binding Theory expresses conditions on the well-formedness of sentences that contain anaphors, pronouns and referential expressions (henceforth R-expressions). This topic has been the main concern of an extensive array of studies that have started out with Chomsky's 1981 *Lectures on Government and Binding*. The conditions that are intended to explain the distribution of anaphors, pronouns and R-expressions have come to be known under the names: Principle A, B and C. Here they are, in the 1981 version:

1. An anaphor is bound in its governing category Principle A
2. A pronominal is free in its governing category Principle B
3. An R-expression is free Principle C
4. *Governing Category*
 β is a governing category for α if and only if β is the minimal category containing α , a governor of α , and a SUBJECT accessible to α ¹.
5. *Binding*
 α binds β iff α and β are coindexed and α c-commands β , where coindexing requires non-distinctness in features.

The notion of c-command is most easily explained as follows:

6. α c-commands β iff α is a sister of γ containing β :
 α [γ β ]

¹ An accessible SUBJECT is defined as follows: "a is accessible to b if and only if b is c-commanded by a and coindexing of a and b would not violate the i-within-i condition".

14 *Basic facts about binding*

The different behaviour of all these types of phrases with respect to Binding Theory (henceforth BT) comes from their different referential properties. Anaphors show referential deficiency, therefore, they need to be linked up to closest available antecedent in order to get interpreted. The impossibility to use them deictically ties in with their referential deficiency. Pronouns, on the other hand, have some referential strength of their own (i.e. they allow for deictic use) and do not have to seek interpretation via an antecedent within a local domain. R-expressions are fully referential, hence they will never be interpreted via an antecedent².

Let us have a closer look at the notion of *binding principles* in an attempt to get a better grasp of what they are really about, beyond the basic interpretative intuitions that I have just outlined. A very important point about the duality of their nature has been made by Reuland 2001. He notes that the way the principles pertaining to BT are phrased in the formulation (1) through (5) entails that they rely on both syntactic and semantic notions. The syntactic part has to do with the presence in the definitions of the concept of (minimal) governing category or, to put it in more plain terms, with the syntactically defined domain of locality within which anaphors³ have to find their antecedents. The semantic part involves the fact that these are interpretative principles. The coindexation relation that holds between the anaphor and its antecedent (see (5)) indicates that they must be interpretively dependent, that is, the anaphor depends for its interpretation on the antecedent. No wonder then that binding has been regarded to be a syntax - semantics interface phenomenon. Another noteworthy aspect is that nothing in the formulation of these principles says anything about the reasons why they should hold at all. One might dismiss such preoccupations as being quite trivial and simply take on the view that the different referential properties of anaphors, pronouns and R-expressions justify the existence of these conditions on their interpretation. However, at a closer look, the notion of *referential deficiency* itself turns out not to

² Of course, one should keep in mind the special status of epithets (i.e. *the bastard*, *the idiot*, etc.), which are R-expressions and yet link up to antecedents.

³ Note that I'm making reference only to anaphors and pronouns and, implicitly, only to Principles A and B. I do not discuss Principle C because it has been argued to result from discourse, and pragmatics considerations (Reinhart 1983).

have a proper definition. Moreover, even if a certain lexical item has been tagged as *referentially deficient*, this does not necessarily imply that the respective item has missed its chance to get an interpretation (see Reuland 2005 b). Keeping in mind these two points, it is not surprising that principles A, B and C in the 1981 version have the uncertain flavour of stipulations. Ideally, they should be derived from basic (conceptually necessary) facts regarding the nature of anaphors and pronouns. This smoothes down my transition to the next topic I would like to broach, which is the status of BT in the most recent version of the Minimalist Program.

The shift that linguistic theory has made from the Government and Binding framework, henceforth GB, to the minimalist program (Chomsky 1995 and subsequent work), henceforth MP, has prompted linguistic research to rethink the fundamental issues regarding the organization of language. The main concern of the minimalist program has been to eliminate from linguistic theory all the aspects that cannot be conceived of in terms of virtual conceptual necessity. A well-known example involves the levels of linguistic representation d-structure and s-structure whose presence in the organization of language cannot be fully motivated because they do not directly relate to what goes on at the interface between the language faculty and the cognitive systems that interact with it, i.e. the articulatory – perceptual system and the conceptual intensional one. Given the fact that linguistic expressions are pairs of sound and meaning, the only levels of linguistic representation whose presence can be justified on a conceptually necessary basis are the sensory – motor interface (SM) and the conceptual – intensional interface (C-I).

Binding theory itself needs rethinking within the theoretical framework provided by the MP. This is not just because some binding facts were argued to be resolved at the s-structure level, but also because the principles themselves need to be grounded on a firmer conceptual foothold. Recent work in the field (Reuland 2001, 2005 a) has taken up the task to go to the fundamentals of the binding principles A and B and put them up to scrutiny with the minimalist magnifying glass.

Let us return to Principle A in the formulation above, which constrains the distribution of anaphors. Chomsky (op. cit) as well as subsequent studies by other authors take the term to refer either to (i) reflexive pronouns such as the

16 *Basic facts about binding*

English *himself* or to (ii) reciprocal pronouns, the *each other* type⁴. Hence Principle A accounts for the grammaticality of (7a) and also for the ungrammaticality of (7b) in terms of (i) the way the minimal governing category for the reflexive pronoun is calculated and (ii) also in terms of assessing whether the reflexive is bound within this category or not.

7. a. John_i hates himself_i.
- b. *John_i knows that the kids hate himself_i.

In (7a) the sentence represents the governing category for the reflexive *himself* because it includes the reflexive pronoun itself, the governor of the pronoun (the verb *hate*) and an accessible SUBJECT (*John*). The subject *John* binds the object *himself* within this minimal governing category and the result is a grammatical sentence. *Himself* in (7b), on the other hand, has as its governing category the complement clause, it also has a governor and an accessible SUBJECT, but it lacks an appropriate antecedent, since due to the number mismatch *the kids* cannot be coindexed with *himself*. Although *himself* is c-commanded by *John* and can be coindexed with the latter, this does not rescue the sentence, since *John* is outside the governing category of *himself* and hence "too far away". Principle B constrains the distribution of pronouns and it explains why (8), which contains a pronoun, is not grammatical if it takes on the bound reading (i.e. the whole sentence in (8) counts as the governing category for *him* and *him* is therefore bound within this domain by the subject *John*, in violation of (2)).

8. *John_i hates him_i.

Note that both the well-formedness of the reflexive pronoun in (7) and the ungrammaticality of the pronoun in (8) are assessed in terms of the structural configuration they occur in. The formulation of Principle A and B predicts that reflexive pronouns and pronouns should be at all times in complementary distribution. However, numerous studies couched in the GB framework have shown at length that Principles A and B of BT fail in their attempt to give a foolproof account of the distribution of anaphors and pronouns. It is common

⁴ Since the contrast between reflexives and reciprocals is of no concern for this dissertation, I will refrain from discussing reciprocals.

knowledge that their purported complementarity collapses in contexts that involve reflexives and pronouns embedded in DPs, i.e. DP-anaphors (see (9a), or occupying adjunct positions, as shown in (9b) (cf. Lees and Klima 1963, Lakoff 1968, Chomsky 1981, Koster 1985, Kuno 1987, and references cited there).

9. a. Max_i likes jokes about himself_i/him_i.
- b. Max_i saw a gun near himself_i/him_i.

The failure has partly to do with the fact that BT has been conceived of in configurational terms. Moreover, there is also an important shortcoming of a different nature to be taken into account. BT has been devised for languages that have a bi-partite distinction between reflexive pronouns and full pronouns, but there are languages whose anaphoric systems contain a three-way or even four-way distinction (see many of the contributions in Koster and Reuland 1991, and the references cited there⁵, Reinhart and Reuland 1993 (henceforth R&R), Reuland 2001, 2005b). Those languages have bare reflexives (also called SE anaphors in R&R, a term I will also adopt), such as Dutch *zich* or Icelandic *sig*, in addition to the reflexive pronouns (also known as SELF anaphors) and full pronouns. It is not at all clear how to deal with these languages using the instruments provided by BT because no special conditions have been devised to take care of them and the way they need to be interpreted.

R&R have looked for solutions to the problems related to the breakdown of the predicted anaphor – pronoun complementary distribution and also to those related to what exactly governs the distribution of SE anaphors and pronouns. They proposed a modular approach to BT: Principles A and B are not sensitive to hierarchy and only regulate the interpretation of reflexive predicates. The hierarchical part of the binding conditions is captured by chain theory, as will be discussed later.

Reflexivity is a property of predicates.

10. Definitions

- a. The *syntactic predicate* formed of (a head) P is P, all its syntactic arguments, and an external argument of P (subject).

⁵ Everaert (1986, 1991), Hellan (1980, 1987), Koster (1985, 1987), Maling (1982, 1984), Pica (1984, 1985, 1987), Thráinsson (1976, 1979, 1990), a.o.

18 Basic facts about binding

The *syntactic arguments* of P are the projections assigned Θ -role or Case by P.

- b. The *semantic predicate* formed of P is P and all its arguments at the relevant semantic level.
 - c. A predicate is *reflexive* iff two of its arguments are coindexed.
 - d. A predicate (formed of P) is *reflexive-marked* iff either P is lexically reflexive or one of P's arguments is a SELF anaphor.
11. a. Condition B: A reflexive predicate is reflexive-marked
b. Condition A: A reflexive-marked predicate is reflexive

That reflexivity is a property of predicates can be shown by minimal pairs like the following.

12. a. *Max haat zich.
Max hates se
"Max hates himself".
- b. Max wast zich.
Max washes se
"Max washed (himself)".

Haten in (12a) is a reflexive predicate, and the ungrammaticality of the sentence arises from the fact that there is nothing to mark that it as reflexive. The SELF anaphor *zichzelf* would have done the job (see definition (10 d))⁶ *Wassen*, on the other hand, has an inherently reflexive entry and as such it does not need the SELF anaphor to mark reflexivity; it would be redundant. Moreover, since the predicate bears its inherent reflexive marking, *zich* is allowed to cooccur with it. (See also Everaert 1986 on the contrast between (12 a) and (12 b)).

⁶ *Zichzelf* behaves as a reflexive marker, but *zich* lacks this property (see the discussion on the [\pm reflexivity marker] property later in the present section).

At this point, it is useful to remark that, for Chomsky, reflexive pronouns are anaphors and they need to be locally bound. Being referentially deficient, binding provides them with a way to get an interpretation. In other words, being a reflexive pronoun goes hand in hand with being necessarily bound in order to be interpreted. For R&R, reflexivity is a property of predicates, as I have already pointed out. Reflexive predicates have to be marked as such. This marking shows on the morphology of the verb (in the form of a specialized clitic, for instance) or on the choice of the form of the internal argument. Romance and Slavic languages exemplify the first case and display reflexivity on the verb's morphology. Germanic languages go for the second option and make use of reflexive pronouns to license reflexivity. For instance, in English the reflexive pronoun *himself* takes on this task to mark reflexivity (unless the predicate is inherently reflexive, in which case no external marker of reflexivization need be employed). On this view, reflexivity divorces from binding. This is a crucial fact that I will take for granted throughout this dissertation. It is grounded in the observation that predicates can be reflexive without their internal argument being bound to the external one (Reuland 2005 b and references therein). For instance (13) gets a reflexive interpretation even if the reflexive pronoun *themselves* is not present.

13. The children washed.

This brings me to the first theoretical clarification point I would like to make. That is, I will adopt the view that reflexivity does not necessarily relate to binding⁷. What is reflexivity then, how can it be defined? Reinhart (2002), Reinhart and Sioni (2005) have proposed that reflexivization is a parameterizable operation that applies to the argument structure of a predicate (see section 2.1. for more details).

Besides rethinking Principles A and B as conditions that regulate the behaviour of reflexive predicates, R&R 1993 have also proposed that some cases

⁷ Note that my formulation of this point is not quite accurate because both BT and the new proposal in R&R rely on coindexation. The difference is that BT refers to syntactically coindexed positions whereas R&R have in mind coindexation of co-arguments of a predicate. However, indices do not have any conceptual justification in the MP (Chomsky 2001, 2004, 2005). This is why I stick to the claim that licensing of reflexivity and binding do not go hand in hand.

20 *Basic facts about binding*

that were initially taken to be the subject matter of Principle A and B are better captured not in terms of BT, but of chain formation (reflexive pronouns that function as subjects of ECM and small clauses). For instance, the grammaticality contrast between (14 a) and (b), quoted from Reuland 2001, is not due to violation of reflexivity conditions but boils down to restrictions on chain formation.

14. a. John_i thinks himself_i to be smart.
b. *John_i thinks him_i to be smart.

In cases such as (14), which do not involve reflexivity marking on co-arguments, the authors suggest that the reflexive pronoun relates to its matrix subject antecedent as a result of an Argument-Chain definition (henceforth A-Chain).⁸ A-Chains abide by the following condition:

15. Condition on A-Chains
A maximal A-Chain ($\alpha_1 \dots \alpha_n$) contains exactly one link – α_1 – that is both +R and Case-marked (R&R: 696).

I want to make a small digression here and discuss the [\pm R] notion (the notation stands for *referential independence*). This is a morpho-syntactic feature that R&R have used, together with the [\pm reflexivity marker] feature, to characterize anaphoric systems typologically. A lexical item is [+R] only if it is fully specified for the ϕ features person, number, gender and case. If it is not, then it counts as [-R]. The different specification for this feature has consequences for the semantic interpretation of lexical items.

Given that pronouns, but not bare reflexives (or reflexives of the *himself* type⁹) count as +R, it becomes clear that bare reflexives tail A-Chains, but

⁸ Generalized chain definition (R&R: 693)

- $C = (\alpha_1 \dots \alpha_n)$ is a chain iff C is the maximal sequence such that
- there is an index i such that of all j , $1 \leq j \leq n$, α_j carries the index, and
 - for all j , $1 \leq j \leq n$, α_j governs α_{j+1}

⁹ *Himself* in (14 a) bears full specifications for person, number, gender. R&R (1993) argue that *himself* is underspecified for case. Anagnostopoulou & Everaert (1999), however claim that there is no underspecification, and this raises the question why it is [-R] at all. I

pronouns do not. Hence, the grammaticality contrast between the two sentences in (14).

It has become clear by now that the scope of Principles A and B in the formulation in (1) and (2) has split up and has extended its coverage. These principles check whether a certain predicate is reflexive and properly marked as such. Reflexivity holds of the co-arguments of a predicate and, for those languages that license it on arguments, SELF anaphors only act as reflexive markers. Since neither SE anaphors nor pronouns have anything to do with reflexivity licensing, Principles A and B do not have anything to say about them. They share the property of not counting as reflexivity markers, but are different with respect to their specification for the [\pm referential independence] property. SE anaphors are [-R], but pronouns are [+R]. Their distributional patterns are dictated by the way their referential deficiency (or lack of that) interacts with the process of linking up to an antecedent and to chain formation¹⁰. Let me be more explicit about this issue and look at the following examples from Dutch (the discussion that follows picks up on the issue introduced by (14)).

16. a. Jan_i hoorde zich_i zingen.
Jan heard SE sing.
- b. *Jan_i hoorde hem_i zingen.
Jan heard him sing.

Horen in (16 a) is not a reflexive predicate because the coindexed *Jan* and *zich* are not co-arguments of this predicate (*zich* is the external argument of the ECM clause). *Zich* is underspecified with respect to ϕ features (it has third person, but no number and gender specification), it counts as [-R] and, crucially, it occupies an argument position, that of the ECM clause subject. This qualifies it to enter a dependency with the matrix Tense node (see footnote 10) and pick up the features of the matrix subject. To put it differently, it qualifies it to enter a well-

will adopt the view that referential deficiency has to do with the *-self* part of this reflexive (see Reuland 2005 b).

¹⁰ Chain formation resulted from covert movement of the features of the bare reflexive to I (see Reinhart and Reuland 1991). In the 1993 framework, chain formation involves no movement; the chain is representational. Later, the respective chain results from the application of Agree (Reuland 2005 a).

22 Basic facts about binding

formed A-Chain. The pronoun *hem*, on the other hand, bears a complete specification for ϕ features, which makes it a [+R] constituent. As such, it cannot tail a well-formed A-Chain, according to the condition in (15). Note, however, that I follow Reuland 2001, 2005 b in assuming that referential deficiency does not tamper in any way with the possibility of an underspecified element to be interpreted. A good illustration for this point comes from the Icelandic *sig*¹¹, a referentially deficient SE anaphor.

The conclusion that I would like to draw so far has to do with relation of binding to movement. The above mentioned split within the scope of Principle A and B opens up the possibility for a part of BT (i.e. the cases that involve A-Chain formation) to be treated in different terms (see, again, footnote 10). From a minimalist perspective, it is worth investigating why certain reflexive pronouns, i.e. bare reflexives, are liable to undergo movement and enter chain formation. The answer lies in the morphological make-up of the respective reflexive pronouns (I will come back to this issue later). This point about binding and movement forces me to go back and reconsider a remark I have made at the beginning of this section. I noted that binding has been regarded as a phenomenon that operates at the interface between syntax and semantics. I will follow Reuland 2001 in assuming that binding is not entirely handled at the interpretive interface. To put it differently, binding does have a “*syntactic residue*”. Moreover, the part of binding handled by syntax obeys the locality (phase-sensitive dependencies) and economy requirements that apply to syntactic derivations (Reuland to appear). However, the story does not end here because I have not said anything about what goes beyond the syntactic residue of binding. Reuland 2001 proposes a view on the strategies that languages use to mark the dependency between a pronoun and its antecedent. His account considers the number of “steps” that have to be taken to form the dependency (within narrow syntax or at the C-I interface). More precisely, he argues that the least costly, therefore the most economical strategy is to form an A-Chain in syntax that connects a reflexive pronoun to its antecedent by means of feature

¹¹ Icelandic *sig* might take up positions that are not traditionally associated to the notion of *anaphor*. That is, in certain environments it does not necessarily need a c-commanding antecedent or one available within a limited search domain (cf. minimal governing category). However, such contexts of occurrence do not prevent *sig* from getting an interpretation in discourse, rather than a syntactically encoded one (see Chapter 3 for details).

movement (this takes place only in the restricted contexts I have alluded to above). This entails that the respective A-Chain will be interpreted as a single variable at the C-I interface, and, consequently, this type of dependency involves two steps, i.e. chain formation in syntax and translation of this chain into a variable at the syntax-semantics interface. If an A-Chain cannot be formed in syntax, the anaphor and its antecedent will each get interpreted as variables at the interface, but this means they represent different (trivial) chains in syntax, and the number of “steps” encoding this dependency goes up to three, two chain formations in syntax and the translation of this chain as one chain at the interface. Finally, it might just be the case that that no A-Chain is formed either in syntax or at the interface and the anaphor is assigned an interpretation from discourse storage.

The pronouns that for some reason or another do not enter chain formation in syntax could be either translated as bound variables at the level of logical syntax or they could corefer with their antecedent or they could also link up to an antecedent in discourse.

1.2. Coreference and bound variable readings

I would like to say a few things about bound variable readings, coreference and the main points on which they differ. One way to tease bound variable readings apart from coreference would be to show that they are handled at different levels of linguistic representation. Reinhart 1983a puts forth the view that bound variable readings are encoded in semantics, whereas coreference relations obtain because of pragmatic or discourse reasons. The pronominal lexical items that end up interpreted as bound variables are c-commanded by their antecedents *and* coindexed to them. Coindexation yields a bound variable interpretation only under c-command. If c-command does not obtain, coindexation is only compatible with a coreferent reading, and hence requires a referential antecedent, as illustrated in Heim (1981)'s famous example in (17):

17. a. That soldier_i has a gun. Will he_i shoot?
- b. No soldier_i has a gun. *Will he_i shoot?

24 *Basic facts about binding*

Note that this kind of view on semantic dependence assumes that indices do have import as linguistic entities, a theoretical stand that the MP will challenge.

In what follows I will briefly sum up the arguments in favour of treating bound variable readings separately from coreferent readings. First, there is the c-command issue, as I have already said. Reinhart discusses bound variable readings and establishes that they hold under c-command (i.e. the antecedent has to c-command the pronoun that gets interpreted as a bound variable). Coreference, on the other hand, does not involve c-command. Let us have a look at a pair of examples (op. cit. 164, 167), where italics indicate the intended readings.

18. a. Those who know *her* respect *Zelda*.
- b. *Felix* thinks that *he* is a genius.

A bound variable reading could obtain only in (18 b), where *Felix* c-commands the pronoun, but not in (18 a) because *Zelda* does not c-command *her*. In the latter case the pronoun is free to corefer with *Zelda*, to pick an antecedent from the previous discourse or to be interpreted deictically. In the former, the pronoun ends up coindexed and variable bound to *Felix*. The question is what goes on in (19), where c-command holds between *he* and *Felix*?

19. *He* thinks that *Felix* is a genius.

For the pronoun to get the bound variable interpretation, something like configuration (18 b) would have been necessary (i.e. *Felix* should have c-commanded *he*). The bound variable reading being ruled out, the next question is whether *Felix* could be coreferent with *he*? Reinhart's answer is negative. She proposes that, if the speaker had intended coreference, he or she would have picked the (18 b) option. Choosing (19) over (18 b) means that no coreference has been intended. This kind of choice prioritizing strategy, i.e. opt for coreference or not, belongs to class of pragmatic strategies.

Reinhart shows that there could be cases in which speakers prefer a coreferent interpretation to a bound variable one because they want to convey a certain meaning that the latter cannot capture. Compare to this end (20 a) and (20 b):

20. a. I know what Bill and Mary have in common. Mary adores him and Bill adores him too.
 b. I know what Bill and Mary have in common. Mary adores him and Bill adores himself too.

What *Mary* and *Bill* have in common is not the property $\lambda x (x \text{ adores } x)$, i.e. the property of self-adoration, but rather $\lambda x (x \text{ adores } \text{him}=\text{Bill})$, i.e. the property of Bill-adoration. This is expressed by (20 a) rather than (20 b), which is why (20 a) is allowed. The main insight is then that a coreferent reading becomes an option only if it conveys something that a bound variable reading does not capture. This is captured by Rule I as it is formulated in Grodzinsky and Reinhart (1993):

21. *Rule I: Intrasentential coreference*
 NP A cannot corefer with NP B if replacing A with C, C a variable A-bound by B, yields an indistinguishable interpretation.

It should be noted that this rule is modified in Reinhart (2000). However, the details of the modification do not immediately concern us here. It is important, though, that Reinhart (2000) proposes a semantic definition of binding that is not based on the syntactic notion of an index as in the canonical BT. This is an important prerequisite for a minimalist approach to binding, as taken in this dissertation, since, as noted earlier, the status of indices is problematic in the minimalist program. Reinhart gives the following definition, which will be adopted in this dissertation:

22. *A-binding*
 α A-binds β iff α is the sister of a λ predicate whose operator binds β .

I use the term *coreference*, or *covaluation*, in the sense of Reinhart (2000).

23. *Covaluation*
 α and β are covalued iff neither A-binds the other and they are assigned the same value.

To cite an example from her, (24) supports the readings in (25):

26 *Basic facts about binding*

24. Only Lucie respects her husband
25. a. Only Lucie (λx (x respects x's husband))
b. Only Lucie (λx (x respects her husband) & her = Lucie)

The first reading entails that Lucie is the only woman who respects her husband (the bound reading in Reinhart's sense). The second one entails that other women do not respect Lucie's husband (the covalued or coreferent reading).

1.3. **A few introductory remarks on reflexivization strategies**

Recall that reflexivity should be understood as a property of predicates and that it has to be marked accordingly. Typological studies concur with this point. They have also shown that there is a cross-linguistic need for reflexive readings to be licensed or marked and languages use different means to do accomplish this task (a.o. Schladt 2000, Dimitriadis & Everaert 2004). I will refer to these means as reflexivization strategies¹². Let me flesh out this notion a bit. It has become clear from the discussion in the previous section about Principles A and B recast in terms of the R&R 1993 framework that languages like English employ reflexive markers such as *himself*, a reflexive anaphor, to license reflexivity. This situation holds throughout all the Germanic languages¹², i.e. all of them mark reflexivity on the internal argument of a reflexive predicate. Romance languages, on the other hand, employ the reflexive clitic *se* to show that the reflexivization operation has applied (see below). Hence, the use of clitics also instantiates a reflexivization strategy. Last, but not least, it might also be that, under certain circumstances, bare reflexives and pronouns show up in contexts that are compatible with a reflexive interpretation. This phenomenon does not count as a reflexivization strategy per se, but will be nevertheless discussed here.

¹² Note that Icelandic as well as other Scandinavian languages, such as Swedish, illustrate a more complex case. The suffixes *-st* and *-s* could mark reflexivity in Icelandic and Swedish, respectively.

This section aims at surveying all the reflexivization strategies employed by Romanian. It will not go much beyond a simple typological description. In the course of the presentation of reflexivization strategies, I will classify the Romanian anaphoric system according to the features [\pm reflexive marker], [\pm referential independence]. The [\pm reflexive marker] feature will end up discriminating between what counts as a reflexive marker and what not. The [\pm referential independence] feature type will be useful for a deeper understanding of the behavior of anaphoric elements, i.e. whether they are prone to enter syntactic encoded dependencies.

I will return to this classification later on, in Chapter 4, and further refine it by employing more distinctive features (Reuland 2005 b). To anticipate the discussion a little, I commit myself to claiming that only the reflexive clitics bear the positive value for the reflexivity marker feature.

The remainder of this chapter will develop as follows. In the second section, I will concentrate on reflexive cliticization. I will show that the reflexive clitic *se* is used to mark that reflexivization has taken place on the predicate. When cliticization is prevented because the object of the verb is a prepositional object, the tonic counterpart of the reflexive clitic, *sine* might associate itself to a locally bound reading. In the third and fourth sections, I will discuss the fact that the Romanian anaphoric system also includes the emphatic forms *sine însuși* / *sine însăși* (SE self) and *el însuși* / *ea însăși*, a word by word translation of English *he himself* / *she herself*, and the full pronoun *el* / *ea* (he / she). Just like the bare reflexive *sine*, the emphatic forms and the pronouns could be compatible with contexts that render a reflexive reading. They do not act as reflexive markers.

2. SE-Reflexives

2.1. Se

I have mentioned in section 1 that reflexivity is a property of predicates and it is defined over argument structure. An important research topic is to determine how exactly this property is licensed. To bring the problem home a little, Romance languages mark reflexivization by using the reflexive clitic *se*. The status of *se* is debatable. Some studies (Dobrovie-Sorin 1998, Rizzi 1986 a, Kayne 1988, Mc Ginnis 1999, Pesetsky 1995, a.o) argue that the clitic is an argument of the verb (i.e. the internal or the external argument. Others (Marantz

28 *Basic facts about binding*

1984, Grimshaw 1990, Reinhart 2000, 2002, Reinhart and Siloni 2005, a.o) take it to be the morphologic reflex of an operation that reduces the arity of a predicate, i.e. the morphological evidence that reflexivization has applied. In the latter case *se* is not an argument. Different predictions follow from the two approaches. One of the most important regards the nature of reflexive predicates. The proponents of the argument analysis treat the reflexive clitic on a par with object clitics (i.e. it checks accusative case). Consequently, they view reflexive predicates as transitive ones, in which both nominative and accusative case get checked. The defenders of the non-argument analysis take the reflexive clitic to be an arity reducing element, or just to mark that arity-reduction has taken place. Theta role reduction bears on the accusative case assigning property of reflexive predicates. Reinhart and Siloni (2005), henceforth R&S argue that accusative case has in principle two components, a structural component and a thematic component. Reduction/bundling of the internal theta role eliminates the thematic component of the accusative case. In languages such as English, with an impoverished case system, no residual structural case is left, hence no element is needed to check it (remember the fact that reflexive verbs such as *wash* may occur without an object, as in *John washed*). In other languages – Dutch, for instance – the lexical operation leaves a residual structural accusative case, which has to be checked. The effect of *zich* in *John waste zich* 'John washed SE' is then to check this residual case. For clitic languages such as Romanian, a further option is then that the clitic is there to check a residual case, along the lines of Dutch *zich*.

Depending on which theta role gets reduced, reflexive predicates have been taken to behave either as unaccusative or as unergative predicates (Marantz 1984, Grimshaw 1990, Grimshaw 1982, Reinhart and Siloni 2005, a.o). However, there is something special about the semantics of reflexive predicates. R&S note the following “*Roughly, by reflexive verbs we mean verbs denoting an action that the Agent argument applies to itself, or, in certain languages, a state of mind the Experiencer argument has with regard to itself*” (R&S: 390). The analysis of reflexivization they give, based on the non-argument status of reflexive clitics, offers an explanation for this basic intuition about the interpretation of these predicates. Reflexivization is taken to be an operation that targets the argument structure of a predicate and bundles the internal theta role to the external one. The result is that reflexive verbs behave as intransitive predicates, but retain the

semantics of transitive ones. Bundling, as its name implies, forms a complex theta role and is defined in (26 a) (p. 400):

26. *Reflexivization bundling*
 a. $[\theta_i] [\theta_j] \rightarrow [\theta_i - \theta_j]$, where θ_i is an external θ role.

R&S argue that theta role bundling is a parameterizable operation that may take place either in lexicon or in syntax. They dub this The *Syntax - Lexicon Parameter* (cf. 26 b):

The Syntax - Lexicon Parameter

- b. Universal Grammar allows arity operations to apply in the lexicon or syntax.

In their system, θ roles are not primitives, but clusters that include the features [c(ause) change] and [m(ental) state] (see references for more details). These features can bear an all the way + specification, i.e. [+c+m], [+c], [+m], an all the way – specification, i.e. [-c-m], [-c], [-m], or mixed specifications, i.e. [+c-m], [-c+m]. A mapping procedure regulates the way these clusters are merged into argument positions. Clusters that bear the [+] specification are assigned the merging index 1 and have to be merged externally (if possible). Those that merge as internal arguments have the merging index 2 and are specified as [-]. The mixed clusters, with both + and – specifications, do not get a default merging index and, consequently, can merge either externally or internally¹³. To see more concretely works, let me walk through a French example given in R&S.

27. Jean se lave.
 Jean SEREF.L washes.
 “Jean washes”.

The reflexive clitic *se* checks the accusative case feature on the verb. As a result of case checking, the internal theta role cannot be assigned to the internal argument and it will be stored with the verb until merge of the external

¹³ All things considered, external merge is preferable over internal merge, according to the authors.

30 *Basic facts about binding*

argument applies. After the external argument has been merged, the theta role that has been retained is bundled with the external theta role. Note that R&S propose an unergative analysis of reflexive predicates.

Let us see turn to reflexivization in Romanian. The presence of the reflexive clitic on the verb marks the application of this operation.

28. a. George spală pisica.
George washes cat.the.
“George washes the cat”.
- b. George se spală.
George SEREF.L washes.
“George washes himself”.

In what follows I will first look at the effects reflexive cliticization has on the (transitive) predicates it applies to. In particular, I will examine what happens to the object position of reflexive verbs, i.e. whether it is still available in syntax, and to the accusative case feature on the transitive cognate of the reflexive entry. Afterwards, I will briefly consider the possible accounts for the reflexivization operation in Romanian and choose one that best fits the data.

I believe there is evidence that indicates the direct object position is syntactically present with reflexive verbs. The evidence comes from resultative constructions, reflexive clitic doubling and ECM constructions selected by reflexive predicates. Resultative constructions in Romanian modify the direct objects of transitive verbs.

29. a. George a făcut mașina praf.
George has made car.the dust
“George destroyed the car to pieces”.
- b. Boxerul l-a bătut măr.
Boxer.the him_{CL} has beaten apple
“The boxer beat him black and blue”.

Reflexive verbs can be followed by resultative constructions. I take this as indication that these resultatives modify their object.

30. a. George se imbată turtă in fiecare zi.
George SREFL.CL gets.drunk into.a porridge in every day
“George drinks himself silly every day”.
- b. Copilul s-a dezbrăcat la piele și a fugit în stradă.
Child.the SREFL.CL has undressed at skin and has run into street
“The child stripped himself naked and ran into the street”.

Reflexive predicates allow for their clitic to be doubled. This is a quite productive phenomenon, even though it is optional (which I have marked by bracketing the double of the reflexive).

31. a. George se admiră (pe sine).
George SREFL.CL admires on self
“George admires himself”.
- b. George se citează (pe sine) tot timpul.
George SREFL.CL quotes on self all time.the
“George quotes himself all the time”.

Of course, one might rightly wonder whether the doubling phenomenon illustrated by (31) is indeed clitic doubling. In section 2.2., I will argue more extensively that the PP in (31) does behave as an argument (see examples (51 c), (52 c) and (53 e)). Not only do reflexive predicates allow for clitic doubling, but they can also select ECM predicates, as (32) shows:

32. George se vede pe sine câștigător în alegeri.
George SREFL.CL sees on self winner in elections
“George sees himself winner in the elections”.

For the time being, I believe that the evidence presented in (30), (31) and (32) suggests that reflexive predicates do have an object position. This point has been made in earlier work on reflexivization in Romanian (C. Dobrovie - Sorin 1994). That work offers an account of reflexivization in terms of binding. More precisely, the reflexive clitic merges in its surface position, i.e. cliticizes on Tense, and from there it binds (and it is consequently coindexed with) a null

32 *Basic facts about binding*

argument in object position. Since I have previously mentioned that I adopt the view according to which reflexivity marking and binding need not be at all connected, I would like to pursue an alternative line of explanation for reflexivity. I will say that it arises as the result of theta role bundling, in the vein of R&S, but that (at least Romanian) reflexive predicates do not lose the accusative case feature on the verb. The clitic checks it, although the usual provisos must be made to accommodate clitic doubling. Consider (33) below:

33. a. George se admiră pe sine.
George SREFL.CL admires on self
“George admires himself”.
- b. George se admiră pe el însuși.
George SREFL.CL admires on him himself
“George admires himself”.

I take the presence of the reflexive clitic on T to show that theta role bundling has applied to the respective predicate (this basically means that the subject gets to be interpreted as both the Agent and the Theme of the predicate). At the same time, note that reflexive clitic can be doubled either by (i) bare reflexives or (ii) by a *himself* type anaphor.

Note that, if the clitic is not reflexive, no constraint on the type of doubled argument holds (and if the pragmatic conditions voiding condition C violations are met, also a covalued interpretation as in (34 a) goes through). (34 b), as the counterpart of (34 a) with a reflexive clitic is ill-formed, since the pragmatic conditions on voiding a condition C violation cannot be met if the predicate is marked as reflexive:

34. a. George îl admiră pe George.
George himCL.ACC admires on George
“George admires George (i.e. himself)”.
- b. *George se admiră pe George.
George SREFL.CL admires on George
“George admires George (i.e. himself)”.

As for the level where reflexivization applies, I will keep to the delimitation proposed by the Syntax – Lexicon Parameter and argue that Romanian falls in the category of languages that deal with reflexivization in syntax. There is a whole array of tests that lead to this conclusion. I will briefly dwell upon them in what follows.

First, languages that have reflexivization in syntax are very productive in the sense that they can reflexivize any verb that has a [+m] subject (Agent, Experiencer or Cause) in its entry. Reflexivization in lexicon languages, on the other hand, applies only to a limited set of transitive agentive verbs that stays more or less the same cross-linguistically (Reinhart 2000, 2002, Reinhart and Siloni 2005)¹⁴.

Second, syntax languages are predicted to extend the reflexivization operation to arguments of distinct predicates. This could happen to ECM predicates and Romanian allows reflexivization of ECM predicates subjects:

35. a. Max se consideră inteligent.
 Max _{SREFL.CL} considers intelligent
 “Max considers himself intelligent”.
- b. Max se vede președinte.
 Max _{SREFL.CL} sees president
 “Max sees himself as president”.

Third, syntax languages are not picky about the type of internal argument they reflexivize. Consequently, both direct and indirect arguments could be targeted by this operation. Romanian reflexivizes dative arguments in addition to accusative ones:

36. a. Max și-a spart vesela.
 Max to.himself_{REFL.CL.DAT} has broken crockery.the
 “Max has broken his crockery”.

¹⁴ Matters are different with regard to inherent reflexives. They are formed in the lexicon.

34 *Basic facts about binding*

- b. Max își imaginează numai necazuri.
Max to.himself_{REFL.CL.DAT} imagines only troubles.the
“Max imagines (to himself) only troubles”.

Finally, lexicon languages have reflexive nominalizations. These nominalizations display reflexive morphology and are derived in the lexicon from reflexive verbs (the following Hebrew and Hungarian examples are quoted from Reinhart and Siloni):

37. a. hitraxcut (‘self-washing’)
b. mos-akod-as (wash-refl-nom, ‘self-washing’)

Syntax languages, on the other hand, lack this type of nominalization. These nominalizations are the result of a lexicon operation which takes as input the reflexive verbs formed in the lexicon. Lexicon operations cannot possibly take as input reflexive verbs formed in syntax. Consequently, syntax languages will not have event or agent nominalizations that are interpreted as reflexive, but lexicon languages will allow for them. English counts as a lexicon language and has agent nominalizations derived from reflexive verbs.

38. She dresses slowly because she is an elegant dresser.

Dutch is also a lexicon language. It so happens that it allows for event nominalizations that are interpreted as reflexive:

39. Wassen is gezond.
Washing (oneself) is healthy

French, on the other hand is a syntax language. Consequently, the following sentence is impossible as a counterpart of (38):

40. Jean est un excellent habilleur/maquilleur
Jean is an excellent dresser/make-up-er (of others only)

As a syntax language, Romanian should not allow agent nominalizations of reflexive verbs either. Due to restrictions on the formation of such

nominalizations, this prediction is difficult to assess. Note, however, that if it had been possible to derive an agent nominalization from the Romanian verb “*a îmbrăca*”, the equivalent of English *to dress* and to French *habiller*, it would still be impossible for the respective nominalization to have the reflexive interpretation, i.e. it would be interpreted the same as *habilleur* in (40). I illustrate this point in what follows. The agent nominalization *bărbier* could be associated with the reflexive verb *a se bărbieri* (shave oneself). Nevertheless, (41) below does not mean that *George is a self-shaver*.

41. George e un bărbier excelent.
George is a barber excellent
“George is an excellent barber (as a profession)”.

The reflexive clitic paradigm looks heterogeneous. I will list it below and then make a few comments.

Table 1: The reflexive clitic paradigm

Person	Accusative		Dative	
	Singular	Plural	Singular	Plural
1	mă	ne	îmi, mi	ne
2	te	vă	îți, ți	vă
3	se	se	își, și	își, și

The heterogeneous character of the paradigm comes from the fact that the first and second person pronouns, *mă* and *te*, do not change form when employed in reflexive contexts. *Mă* and *te* are mono-morphemic. The final *-ă* in *mă* is an epenthetic vowel, but *-e* in *te* cannot be dropped, as usually happens to epenthetic vowels. However, I do not take this to indicate that *te* is bi-morphemic. The morphemes *m-* and *t-* are fusional; they spell out both the person feature and the number feature. The first and second person singular forms have the corresponding lexically marked plural forms *ne* and *vă*. These are also mono-morphemic and fusional, because the *n-* and *v-* morphemes spell out person and number together. The final vowel in the first person cannot be dropped, but, again, I will not take this as evidence against the mono-morphemicity of these clitic forms.

36 *Basic facts about binding*

The third person might look a bit special because it is the only dedicated reflexive of the entire paradigm. It is underspecified in terms of ϕ features in the sense that the *s-* morpheme spells out third person. The final *-e* is an epenthetic vowel, so it drops whenever the next word begins in a vowel:

42. a. George *se* laudă.
George S_{REFL,CL} praises
“George praises himself”.
- b. George *s-a* laudat.
George S_{REFL,CL} has praised
“George praised himself”.

Se displays number syncretism. Even if the same form fills up the singular and the plural slots in the paradigm, the reflexive clitic shows compatibility with both singular and plural antecedents. This ultimately means that the singular and plural values are there. The underspecification of *se* relates not only to the number syncretism it displays, but also to its deficient case paradigm. The reflexive clitic only has an accusative and a dative case form.

The third person form does not show any gender agreement. As expected, gender insensitivity characterizes the first and second person reflexives as well.

43. a. Pisicile *se* spală des. Plural antecedent
Cats-the S_{REFL,CL} wash often.
“Cats wash themselves often”.
- b. Maria/George *se* spală des. Fem/masc antecedent
Maria/George S_{REFL,CL} washes often.
“Maria/George washes herself/himself often”.

As for the dative paradigm, the same heterogeneity draws attention. The first and second person forms are both personal pronouns and reflexive ones. The initial vowel that shows up in the forms *îmi*, *îți* and *își* does not have any function; it is just a support vowel.

The dative first and second person singular forms spell out person and number fusionally by means of the *m-* and *t-* morphemes. However, they are not mono-morphemic. The final *-i* that shows with all singular forms spells out the dative case.

The third person dative reflexive is also bi-morphemic, with the case morpheme included, and it shows syncretism between singular and plural (both singular and plural antecedent are allowed).

The first and second person plural forms might look a bit out of place because they do not show the case morpheme, but, in fact, they do have the bi-morphemic allomorphs *ni* and *vi* that show up with double object verbs, i.e. whenever there is dative > accusative clitic cluster.

44. Ni/*ne te critica tot timpul.
 To him_{DAT} you_{ACC} criticizes.he all time.the
 “He criticizes you to him all the time”.

2.2. *Sine*

The bare reflexive *sine* does not occur as a direct argument of a verb, as illustrated in (45 b). Rather, it must always occur as the object of a preposition. Consequently, its reflexivization properties cannot be directly contrasted with those of the clitic *se*.

45. a. Amantul se ascunde în dulap.
 Lover.the _{SEREFL.CL} hides in wardrobe.
 “The lover is hiding himself in the wardrobe”.
- b. *Amantul ascunde sine în dulap.
 Lover.the _{SEREFL.CL} hides in wardrobe
 “The lover is hiding himself in the wardrobe”.

In fact, just like Italian *sè*, it could be analyzed as the tonic counterpart of the clitic *se* if we take cliticization to be obligatory in the environments in which it can apply (see Napoli 1976, Reuland 1991). Hence, whenever cliticization is not possible – these being the cases when the object is embedded in a PP – *sine*, as the non-clitic counterpart of *se*, must be used. If so, *sine* should be analyzed as a

38 *Basic facts about binding*

bare reflexive, not a complex reflexive such as Italian *se stesso*. Given that *sine* is an anaphor, it must be bound, and sentences such as (46) receive an interpretation that should qualify as reflexive at some level of interpretation.

46. a. George contează pe sine.
George counts on self.
“George counts on himself”.
- b. George testează medicamente pe sine.
George tests medicines on self
“George tests medicines on himself”.

From these data it emerges quite clearly that the presence of *sine* ties in with the choice for a special type of predicate, i.e. the type that takes argument PPs.

47. Preşedintele crede prea mult în sine.
President.the believes too much in self
“The president believes too much in himself”.

As for the types of PP that can embed the bare reflexive, they are quite varied. They can be small Ps, such as *de* (of), *în* (in), *pe* (on), *la* (at), *cu* (with), as shown in (48).

48. a compara cu sine (compare with), a lupta cu sine (fight with), a vorbi cu sine (talk with), a raporta la sine (to compare with), a renunţa la sine (to give up on), a experimenta pe sine (to experiment on), a incerca pe sine (to try on), a testa pe sine (to test on), a descoperi în sine (to discover in), a vedea în sine (to see in), a crede în sine (to believe in), a lovi în sine (to hit in, figuratively), a râde de sine (to laugh at), a fugi de sine (to run from), a uita de sine (to forget about)

Also ‘big’ PPs can contain the bare reflexive as complement. They can be either non-directional: *despre* (about), *pentru* (for) – see 49 below – or locative *lingă* (near), *sub* (under), *peste* (over) and directional, *spre* (towards), *către* (towards) – see 50.

49. a discuta despre/de (to talk about), a aminti despre/de (to remind of), a spune despre/de (to say about), a dezvălui despre (to reveal about), a folosi pentru sine (to use for), a găti pentru sine (to cook for), a construi pentru sine (to build for), a cumpăra pentru sine (to buy for), a trăi pentru sine (to live for), a munci pentru sine (to work for), a gândi pentru sine (to think for), a plînge pentru sine (to cry for)
50. a pune lângă sine (to put by), a așeza lângă sine (to put by), a pune sub (to put under), a trage peste sine (to pull over), a îndrepta spre (to direct to), a trage către sine (to pull towards), a îndrepta către (to direct towards)

Since the complement status of the PPs exemplified in (48) might not be taken for granted, I would like to offer back up evidence that they can indeed be safely characterized as arguments. To this extent, I will submit them to the extraction out of weak islands test (Cinque 1990).¹⁵ The generally acknowledged prediction is that arguments, but not adjuncts yield grammatical results when extracted out of weak islands.

51. *Factive island*
- a. Am regretat că George a dezvăluit acele secrete despre sine.
Have.I regretted that G has revealed those secrets about self.
“I regretted that George revealed those secrets about himself”.
- b. Despre sine am regretat că a dezvăluit George acele secrete
About self have.I regretted that has revealed G those secrets.
“About himself I regret that George revealed those secrets”.

¹⁵ I would like to note something in connection to the (b) examples in (51) – (53). If uttered with no stress on the moved PP, the sentences might sound a bit odd to a native speaker’s ear. If, however, the moved PPs are placed under focus, the sentences become readily acceptable. I have italicized the PPs in the (c) examples to mark that focalization makes extraction out of weak islands grammatically acceptable (the same examples, but with no stress, are incorrect). The presence of focalization has also made me decide to translate the sentences to English by using cleft constructions.

40 *Basic facts about binding*

- c. *Pe sine*¹⁶ regret că se urăște George.
Himself I regret that SREFL.CL hates George
“It is himself that I regret that George hates”.

52. *Wh-island*

- a. Mă întreb de ce experimentează George pe sine.
Myself_{REFL.CL} ask why experiments G on self
“I wonder why George tests (stuff) on himself”.
- b. Pe sine mă întreb de ce experimentează George?
On self myself_{REFL.CL} ask why experiments G
“On himself I wonder why George tests (stuff)”?
- c. *Pe sine* mă întreb de ce se urăște George?
On self myself_{REFL.CL} ask why SREFL.CL hates George
“It is himself that I wonder why George hates”?

53. *Negative island*

- a. George nu a mâncat ca un porc de data asta.
George not has eaten like a pig of time.the this
“George didn’t eat like a pig this time”.
- b. ?*Cum nu a mâncat George de data asta?
How not has eaten G of time.the this?
“How didn’t George eat this time?”
- c. George nu crede în sine.
George not believes in self.
“George doesn’t believe in himself”.

¹⁶ I have italicized the PPs here to mark that focalization makes extraction out of weak islands grammatically acceptable (the same examples, but with no stress, are incorrect). The presence of focalization has also made me decide to translate the sentences to English by using cleft constructions.

- d. In sine nu crede George.
In self not believes G
“In himself George doesn’t believe”.
- e. *Pe sine* nu se admiră George.
On self not SEREF.L admires George
“It is himself that George does not admire”.

The paradigm of the bare reflexive looks as follows.

Table 2: The bare (simplex) reflexive paradigm¹⁶

Person	Accusative		Dative	
	Singular	Plural	Singular	Plural
1	mine	noi	mie, mi	nouă
2	tine	voi	ție, ți	vouă
3	sine	-	sieși, și	-

As was the case with the reflexive clitic paradigm, the first and second person singular tonic reflexives *mine* and *tine* lead a double life because they show no formal distinctions between their use as personal pronouns and as reflexive pronouns.

The third person form, *sine*, displays almost the same ϕ feature impoverishment as the clitic *se* with the exception that it does not (standardly) allow for third person plural antecedents.

54. *Studentii conteaza pe sine.
Students.the count on self
“The students count on themselves”.

This fact generalizes across Romance. Italian tonic *se* as well as Spanish tonic *sí* are not felicitous with plural DP antecedents (Kayne 2000)

¹⁷ As an aside, note that the bare reflexive has no possessive (genitive) form.

42 *Basic facts about binding*

55. a. ?I ragazzi hanno parlato di sé.
The boys have spoken of se
“The boys spoke of themselves”.
- b. *Los chicos hablaron de sí.
The boys talk about self
“The boys spoke of themselves”

The incompatibility to plural antecedents points to the conclusion that the bare reflexive does not have full number syncretism. I claim that it is grammatically unvalued for number, but semantically singular. The relevance of this particular fact on number specification will be discussed in detail in Chapter 4.

To complete the presentation of the bare reflexive, two more facts need mentioning. First, *sine* does not show gender agreement either (cf. 56 a). Second, it will always take [+ human] antecedents (cf. 56 b)

56. a. Spionul/spioana testează tranchilizante pe sine.
Spy.the_{MASC}/spy.the_{FEM} tests pain killers on self
“The spy tests pain killers on himself/herself.”
- b. *Căinele a pus osul lângă sine.
The dog has put bone.the by self
“The dog put the bone by itself”.

The bare reflexive may be used as an emphatic in two types of contexts: (i) those that involve clitic doubling (see (57)) and (ii) those in which the bare reflexive occupies the subject position of ECM predicates (see (58) and also the discussion on bound pronouns in section 3).

57. George se admiră (pe sine)
George _{SEREFL.CL} admires (on self)
“George admires himself”.

58. Primul ministru se consideră pe sine cel mai deștept.
 Prime.the minister S_{REFL.CL} considers pe_{ACC} self the most smart.
 “The prime minister considers himself the smartest”.

The optionality of *sine* in (57) and (58), which represents in fact a quite productive type (i) of context of occurrence, finds a straightforward explanation if the bare reflexive amounts to nothing else but a means to mark emphasis¹⁸.

The situation in (57) and (58) resembles the cases in which overtly realized subjects get a focalized (contrastive) interpretation whenever they are in free variation with null subjects, *pro*. Only the overtly realized *el* in (59 b) carries along an emphatic nuance (Larson & Lujan 1990):

59. a. Pro trabaja
 Pro Works
 “He works”.
- b. El trabaja
 He works

The emphatic usage of the bare reflexive does not necessarily characterize the cases when it is embedded in PPs because free variation with *pro* does not hold any more. This does not mean that PPs *may* not receive a contrastively focalized reading, but that they certainly *need* not.

The last remark I want to make about the bare reflexive concerns its interpretation. It can only convey total identity overlap with the referent of its antecedent. This is an important respect in which the bare reflexive differs from the complex one. In the section 4, I will have more to say about the interpretation of the complex *el însuși*.

¹⁸ Note that the optionality of *sine* in (57) and (58) also follows from the fact that the predicate is reflexive-marked by the clitic *se*, and thus needs no reflexive marking from *sine*.

2.2.1. Non-local *sine*

An important observation is that *sine* can be non-locally bound. Not all native speakers allow for this possibility, and I will address the issue of varying judgments in Chapter 4, section 2.4 and in the Appendix, which contains a Magnitude Estimation experiment on the acceptability of non-local binding sentences with Romanian native speakers. For now, I will limit myself to discussing the relevant examples.

Quite surprisingly, non-local binding of *sine* does not follow the patterns for binding of SE anaphors in Germanic, as they have been discussed in Everaert (1986), Manzini and Wexler (1986), and various contributions in Koster and Reuland (1991). Just like *sig* in Icelandic, *sine* can be non-locally bound out of subjunctive clauses (see below for more in this). Romanian has two types of subjunctive complements: those introduced by the subjunctive (prepositional) complementizer *ca* and those that are not introduced by this complementizer. The examples below show *sine* bound out of complementizer and complementizerless subjunctive complements.

60. a. Tarzan_i a cerut ca Jane_j să muncească pentru
 Tarzan has asked that_{COMP} SUBJ Jane sa_{SUBJ} work for self
 sine_{i,j} de dimineața pînă seara.
 from morning.the till night.the
 “Tarzan asked that Jane work for herself/himself from morning
 till night”.
- b. Tarzan_i vrea să muncească Jane pentru sine_i de dimineața pînă
 seara.
 Tarzan wants sa_{SUBJ} work Jane for self from morning.the till
 night
61. a. Primul ministru_i speră ca soția lui_j să vadă un lider în sine_{i,j}.
 Prime.the minister hopes that_{COMP} SUBJ wife.the his sa_{SUBJ}
 vadă un lider în sine
 see a leader in self
 “The prime minister hopes that his wife will see a leader in
 herself/himself”.

- b. Primul ministru_i a refuzat sa le vorbească soția lui_j
 Prime.the minister has refused sa_{SUBJ} to them_{CL.DAT} talk wife.the
 despre sine_{i, j} ziariștilor.
 about self to.newspapermen.the_{DAT}
 “The prime minister refused for his wife to talk to the
 newspapermen about herself / himself”.

Non-local binding of bare reflexives out of subjunctive clauses is nothing surprising. It is a cross-linguistically available phenomenon. The following examples show non-local binding of Icelandic *sig* (Thráinsson 1991), Italian *sé* (Everaert 1986) and French *soi* (Pica 1984):

62. a. Jón_i sagði að ég hefði sviðið sig_i.
 John said that I betrayed_{SUBJ} himself
 “John said that I betrayed him”.
- b. Gianni_i vorrebbe che Mario parlasse di sé_i.
 Gianni would like that Mario talk_{SUBJ} about himself
 “Gianni would like Mario to speak about him”.
- c. On_i ne souhaite jamais que les gens dissent du mal de soi_i.
 One never wishes that people slander_{SUBJ} one-self

However, *sine* can be non-locally bound out of indicative clauses as well (cf. 63)

63. a. Alex_i știe că Maria_j uită mereu de sine_{i, j}
 Alex knows that Maria forgets_{SIND} always of self
 (atunci când sînt multe de făcut).
 (whenever there are many to do)
 “Alex knows that Maria always forgets about herself / himself
 (whenever there are many things to do)”.

46 *Basic facts about binding*

- b. Preşedintele_i e convins că primul ministru_j va conta
President.the is convinced that prime.the minister will count_{IND}
mereu pe sine_{i, j}
always on self
“The president is convinced that the prime minister will always
count on the prime minister / the president”.

This is an unexpected result crosslinguistically. Icelandic, for instance, does not allow for non-local binding out of indicative clauses, and the same holds for Italian (Giorgi 1984), and French (Pica 1984).

64. a. *Jón_i heyrði að ég hafði svikið sig_i.
John heard that I had_{IND} betrayed self
“John heard that I betrayed himself”.
- b. ?*Quel dittatore_i ha ditto a Reagan che i governi europei hanno
parlato a lungo di sé_j e delle sue gesta.
That dictator told Reagan that European governments talked_{IND}
for a long time about self and his deeds
- c. *Personne_i ne dit que les gens ont pensé à soi_i.
Nobody says that people thought_{IND} about themselves

So far the conclusion is that bare reflexives allow cross-linguistically for non-local binding, but with parametric restrictions on the subordinate clause type.

In fact, the parametric restrictions do not concern only the type of subordinate. It has been shown that non-local binding out of subjunctive clauses in, for instance, Icelandic is influenced by discourse constraints that restrict the type of antecedents for non-local anaphors. Those antecedents must be perspective holders in discourse. Let us see how this works by looking at the following minimal pair given in Sells 1987.

65. a. Barnið: lét ekki í ljós að það hefði verið hugsað vel um sig.
The child put not in light that there had_{SUBJ} been thought well about sig
“The child didn’t reveal that she had been taken good care of”.
- b. *Barnið: bar þess ekki merki að það hefði verið hugsað vel um sig.
The child bore of it not signs that there had_{SUBJ} been thought well about sig
“The child didn’t look as if she had been taken good care of”.

The only difference between the grammatical (65 a) and the ungrammatical (65 b) lies in the perspective the subject antecedent, *barnið*, takes. In (65 a) the child makes a report from her own point of view. On the contrary, (65 b) presents the point of view of the external speaker, who considers the child was not taken good care of.

In what follows I will investigate the influence of discourse constraints, such as perspective holding antecedents, on non-local binding of the bare reflexive *sine*. As we will see, Romanian is different from Icelandic in that discourse factors do not play a crucial role in licensing non-local binding of *sine*. I will draw on the following argument. I will show that not only perspective-holding internal protagonist subjects (i.e. Self, Source) can antecede *sine*, but also the external speaker may assume the role of perspective holder from the subject, without precluding the respective subject from anteceding *sine*¹⁹.

I will go along with current assumptions and take antecedents that are the source of what is being said as well as those who present what is being as filtered through their own consciousness to be antecedents that assume the role of perspective holders in discourse (Sells 1987, Cole et al 2001). The Source and Self can be predicated of the internal protagonists that antecede *sine*. In (66), *Tarzan* is the internal Source of the communication, which refers to a request made from Tarzan’s point of view.

¹⁹ Cole et al 2001 use the same type of argument to distinguish between non-local binding in Mandarin Chinese and Teochew. The former has non-local binding that does not entail the presence of Source and Self antecedents, whereas the grammaticality of non-local binding in the latter language rests on the availability of Source and Self antecedents.

48 *Basic facts about binding*

66. Tarzan_i a cerut ca Jane să muncească pentru sine_i de
Tarzan has asked that_{COMP.SUBJ} Jane sa_{SUBJ} work for himself from
dimineaua pînă seara.
morning.the till night.the.
“Tarzan asked that Jane work for himself from morning till night”.

Let us check the Self role now.

67. Presedintele_i e convins ca primul ministru_j va conta
President.the is convinced that prime.the minister will count_{IND}
mereu pe sine_{i, j}.
always on self
“The president is convinced that the prime minister will always count
on the prime minister / the president”.

In (67) the matrix subject antecedent, *the president*, qualifies as the Self role. From (66) and (67) one can conclude that *sine* has perspective-holding antecedents. Note, however, that this need not be the case. The external speaker may take over the role of perspective holder from the internal protagonist, which is thus stripped of its Source or Self quality. This shift in perspective does not affect *sine*. The shift of perspective can be brought about by using certain speaker-evaluative adverbs. In (68), the presence of the speaker-evaluative phrase *nesimțitul de* (“that insensitive ...”) does not make *Tarzan* the internal source of the communication any more, but the external speaker who makes a judgement on *Tarzan*.

68. Nesimțitul de Tarzan a cerut ca Jane să muncească
pentru sine de dimineaua pînă seara.
for self from morning.the till evening.the
Insensitive.the of Tarzan has asked that_{COMP.SUBJ} Jane sa_{SUBJ} work
“That insensitive Tarzan asked that Jane work for himself from
morning till night”.

As for the Self role, the usage of adverbs such as *mysteriously*, *inexplicably* indicates that the perspective of the external speaker has cut in. Adverbs like these may be freely used in contexts like (69).

69. Președintele_i e convins că, în mod inexplicabil, primul ministru_j va
 President.the is convinced that, inexplicably, prime.the minister will
 conta mereu pe sine_{i, j}.
 count_{IND} always on self
 “The president is convinced that, inexplicably, the prime minister will
 always count on the prime minister / the president”.

Moreover, not only matrix predicates that take perspective holding subjects can be used in contexts with non-local *sine*, as shown by (70).

70. a. George_i nu era conștient că Maria_j contează pe sine_{i, j}.
 George not was aware that Maria counts on self
 “George was not aware that Maria counts on Maria / George”
- b. George_i nu observase că Maria_j contează pe sine_{i, j}.
 George not noticed that Maria counts on self
 “George had not noticed that Maria counts on Maria / George”.

Finally, note that non-local *sine* needs to be subject-oriented, as (71) shows.

71. Mariei_i i s-a raportat [CP că [Alex_j râde de sine_{i, j}]].
 To Maria_{CL.DAT} S_{REFL.CL} has reported that Alex laughs at self
 “It was reported to Maria that Alex laughs at Maria / Alex”.

Local *sine*, on the other hand, takes both subject and object antecedents (cf. 72). The subject-orientation of non-local *sine* will be discussed in detail in Chapter 3.

50 *Basic facts about binding*

72. Preşedintele_i i-a vorbit primului ministru_j despre sine_{i, j}.
President.the to him_{CL.DAT} has spoken to.prime.the minister_{DAT} about
self
“The president spoke to the prime minister about the prime minister /
the president”.

3. *Bound (and emphatic) pronouns*

Condition B of Binding Theory, as formulated in (2), prohibits pronouns from taking antecedents within a local/minimal domain (governing category).

73. a. Harry_i relies on himself.
b. Harry_i relies on him^{*i/j}.

The ungrammaticality of (73 b) results from the fact that the PP that contains the pronoun is an argument of the verb *rely* (we might assume that the pronoun is case marked by both the verb and the preposition). Argument PPs constitute governing categories for pronouns, but they must be free in the domain delimited by these governing categories.

In contrast to what happens in (73 b), Zribi-Hertz 1995 discusses the case of French locally bound pronouns embedded in PPs. She notes that, depending on the semantic properties of predicates, French pronouns might be related to their antecedent within a minimal domain. She suggests that a predicate such as *bavarder avec* is less prone to have its PP object bound to its subject than a predicate like *parler de*. The same contrast holds of *confier a* and *penser de*²⁰:

²⁰ Zribi-Hertz’s intuition is quite robust, but I can think of contexts in which the distinction between *bavarder* and *parler* might be argued to break down. Imagine that Peter has an extremely talkative wife and everybody knows that about her. Bill visits Peter and he ironically asks him *So, what is your wife doing now?* Quite conceivably, Peter can answer ironically as well:

- 1) Ce sa face? Palavrageste cu ea daca nu are cu cine altcineva
What should she do? Is chatting.pro with her if not has.she with who else
“What do you think she’s doing? She’s chatting with herself because nobody else is around”.

74. a. Pierre_i bavarde avec lui_{?i,z}.
 Pierre chats/is chatting with him
 “Pierre chats with him”.
- b. Pierre_i parle souvent de lui_{i,z}.
 Pierre talks often about him
 “Pierre often talks about him”.
75. a. Pierre_i se confie a lui_{?i,z}.
 Pierre confides/is confiding in him
 “Pierre confides in him”.
- b. Pierre_i pense souvent a lui_{i,z}.
 Pierre thinks often of him
 “Pierre often thinks about him”.

These facts are discussed by Reuland (in press), contrasting them with the corresponding sentences in Dutch, where a SELF form is obligatory throughout. In an extensive overview, De Jong (1996) shows that such local binding of pronominals in PPs is pervasive in what she refers to as 'peripheral Romance'. Reuland argues that the contrast between languages such as French and Dutch can be captured by a parameter concerning the relation between V and P. As witnessed by the possibility of preposition stranding in Dutch-type languages V and P of a complement PP form a syntactic unit, whereas in French-type languages this is not the case. Consequently, at the relevant level in languages of the latter type predicates of the form $\lambda x (x V P(x))$ need no special licensing (the P protects the second occurrence of the variable, see Reuland (in press) and Reuland (2005 b) for extensive discussion).

Data from Romanian show that it, indeed, follows the general pattern of peripheral Romance discussed in De Jong (1996). Pronouns contained in a PP can also establish a dependent reading in a domain that structurally qualifies as local, on a par with bare reflexives. I will take a look at these cases and try to tease apart the differences between bare reflexives and bound pronouns.

52 Basic facts about binding

Three types of contexts admit for bound pronouns: those that involve the pronouns as doubles of the reflexive clitic *se* or the pronouns as subjects of ECM clauses selected by reflexive matrix verbs.

76. a. George_i se_i place pe el_{i,*j}.
George_{SEREFL.CL} likes pe_{ACC} him/self
“George likes himself”.
- b. George_i se_i consideră pe el_{i,*j} cel mai deștept.
George_{SEREFL.CL} pe_{ACC} him/self the most smart
“George considers himself the smartest”.

The third type involves PPs without any added material:

77. George_i conteaza pe el_{i,j}.
George counts on him/self
“George counts on himself”.

Examples (76 a,b) have something in common that sets them apart from (77). In (76), the pronoun must be bound and gets an emphatic interpretation. (77) just represents the general option discussed above. The bound variable reading, which prevailed in (76), does not represent the only interpretative option in this case because the pronoun is free to be bound by the subject or to pair up with an antecedent in discourse.

Of course, it could also be the case that the pronoun or the bare reflexive gets a contrastively focused reading, but this need not necessarily happen; it is optional.

4. *Emphatics: sine însuși, el însuși*

Spoken language allows for two more forms that do not mark reflexivity to appear in contexts that involve a subject – prepositional object dependent reading. These are the emphatic anaphors *sine însuși* (*se oneself*) and *el însuși*, (*he himself*).

78. a. George_i contează pe sine însuși.
George counts on se self
“George counts on him himself”.
- b. George_i contează pe el însuși.
George counts on him himself
“George counts on him himself”.

Keep in mind that both of the above-mentioned examples carry along an emphatic/contrastively focused meaning (i.e. of all the people that George could count on, he counts on his own person).

Let me have a closer look at the PRON-SELF anaphors. Morphologically, *el însuși* bears a complete specification for ϕ features, i.e. person, number, gender and case.

Table 3: The paradigm of the emphatic pronoun

Person	1 st	2 nd	3 rd
Sg. M.	însumi	însuți	însuși
F.	însămi	însați	însași
Pl. M.	înșine	înșivă	înșiși
F.	însene	însevă	înseși, însele

Number specification ties in with the greater referential independence this anaphor enjoys (in contrast to the bare reflexive)²¹.

Distributionally, *el însuși* occupies argument positions, i.e. subject, direct object and prepositional object:

²¹ Postal 1971 proposes that the pronominal forms that can show up in copulative predicates such as *John is the man* refer independently. *El însuși* is grammatical in such a context:

- 1) a. Bill nu e el însuși astăzi
Bill is not he himself today
“Bill is not himself today”.
- b. ?*Bill nu e sine însuși astăzi
Bill is not se self today
“Bill is not himself today”.

54 *Basic facts about binding*

79. a. Președintele vrea să inaugureze el însuși monumentul.
President.the wants s_{SUBJ} inaugurate he himself monument.the
“The president wants he himself to inaugurate the monument”.
- b. Alex se vede pe el însuși în oglindă.
Alex s_{REFL.CL} sees pe_{ACC} him himself in mirror
“Alex sees himself in the mirror”.
- c. Alex s-a împacat cu el însuși.
Alex s_{REFL.CL} has reconciled with him himself
“Alex has reconciled with himself”.

It could also take adjunct positions, i.e. it is embedded in adjunct PPs and or it shows up as an adnominal modifier (see 80 below):

80. a. Steve a văzut crocodilul lângă el însuși.
Steve has seen crocodile.the near him himself
“Steve saw the crocodile near himself”.
- b. Negociatorul însuși a încălcat regulile.
Negotiator.the himself has broken rules.the
“The negotiator himself broke the rules”.

How much of an anaphor is *el însuși*? The battery of set of tests that represent the yardstick by which anaphorhood is measured point out that *el însuși* behaves more like a pronoun, since it can take split antecedents, as shown in (81).

81. Primul ministru a vorbit cu matușa lui despre ei înșiși.
Prime.the minister has spoken with aunt.the his about them
themselves
“The prime minister talked to his aunt about themselves”.

Moreover, it does not require intrasentential antecedents:

82. Alex știa toate detaliile despre program. El însuși îl redactase.
 Alex knew all details.the about program. He himself it_{CLACC} wrote
 down
 “Alex knew all the details about the program. He himself had written
 it down”.

However, it will not be safe to think that the complex reflexive has taken on all the properties of a pronoun. It is well-acknowledged that anaphors are referentially deficient (to different degrees). Referential deficiency shows in the morphological make-up of anaphors either as underspecification for ϕ features (number, for instance) or for case (Reinhart and Reuland 1995, Reuland 2005 b) and it drives the anaphor to seek for an antecedent to relate to²². *El însuși* shows referential deficiency.

The referential deficiency of the complex anaphor is reflected in the sloppy reading this anaphor gets in VP-ellipsis context:

83. Primul ministru vorbește numai despre el însuși și președintele la fel.
 Prime.the minister talks only about him himself and president.the the
 same
 “The prime minister talks only about himself and so does the
 president”.
 = The prime minister talks about himself and the president talks about
 himself
 =*The prime minister talks about himself and the president talks about
 the prime minister

One more case tells the same tale about the referential deficiency of the complex anaphor. Romanian (lexically realized or just *pro*) subject pronouns in subjunctive embedded clauses selected by non-obligatory control verbs may be (i) bound, (ii) coreferent with the matrix clause subjects or (iii) they may pick up a referent in discourse.

²² Lack of complete specification for ϕ features in the feature matrix does not prevent an anaphor to be interpreted, but then it becomes a logophor, a pronominal form that picks up reference in discourse (Reuland on *sig*).

56 *Basic facts about binding*

84. George_i vrea să țină el_{i,j} discursul.
George wants to deliver he speech.the
“George himself wants to deliver the speech”.

In the same context, the complex anaphor has only the option of being bound to the matrix clause subject (i.e. only option (i) that I mentioned above). The coreferent and the discourse readings do not obtain.

85. George_i vrea să țină el însuși_{i,j} discursul.
George wants to deliver he himself speech.the
“George himself wants to deliver the speech”.

Semantically, *el însuși* does not convey identity overlap with the antecedent (that is the job of the bare reflexive *sine*), but it instantiates an approximation of the reference of the antecedent.

The best way to test this effect is to look for contexts that permit an interpretative dissociation between the interpretation of the referent of the antecedent and that of the anaphor. Such contexts instantiate the proxy reading (Reuland 2001). The *Madamme Tussaud* type of context (Jackendoff 1992) points clearly to the fact that the complex reflexive supports the proxy reading. This can be seen in (86), for which we might set up the following scenario. Bill has just entered the Madame Tussaud museum and he has spotted in a corner a statue of himself that he does not like. He got angry and he kicked his statue. A good way to convey this idea would be to use the *însuși* forms rather than the bare reflexive.

86. a. Bill a dat câteva picioare în el însuși.
Bill has given some kicks in him himself
“Bill has kicked himself a couple of times”.
- b. ?*Bill a dat câteva picioare în sine.
Bill has given some kicks in self
“Bill kicked himself a couple of times”.

- c. ??Bill a dat câteva picioare în sine însuși.
Bill has given some kicks in self himself
“Bill kicked himself a couple of times”.

The same set-up as above remains. Only this time, it is dark in the museum and Bill trips on his own statue. The same usage preference as above holds:

87. a. Bill s-a împiedicat de el însuși.
Bill SREFL.CL has tripped on him himself
“Bill tripped on himself”.
- b. ?*Bill s-a împiedicat de sine.
Bill SREFL.CL has tripped on self
“Bill tripped on himself”.
- c. ??Bill s-a împiedicat de sine însuși.
Bill SREFL.CL has tripped on self himself
“Bill has tripped on him himself”.

Another example to show that *el însuși* does not entail identity overlap with its antecedent:

88. a. Primarul Boc se judecă cu el însuși.
Mayor Boc SREFL.CL tries with him himself
“Mayor Boc put himself on trial”.
- b. ?*Primarul Boc se judecă cu sine.
Mayor Boc SREFL.CL tries with self
“Mayor Boc has put himself on trial”.
89. a. Romanul acesta este el însuși.
Novel.the this is he himself
“This novel represents himself”.

58 *Basic facts about binding*

- b. *Romanul acesta este sine.
Novel.the this is se self
“This novel represents himself”.

The availability of *el însuși* for proxy readings ties in with its (almost) complete specification for ϕ features. Remember that a positive value for the [R] feature means that a certain lexical item does not enter a syntax encoded dependency. What is then responsible for the reminiscent anaphoric behavior of *el însuși*? Note that the emphatic *însuși* morphologically decomposes into *însu-*, which in older stages of the language used to be a pronoun on its own, and the possessive dative reflexive clitic *-și*. The same pattern applies to all persons. I speculate that it might be this possessive clitic that is responsible for the anaphoricity of the complex form.

Since *însuși* in the complex anaphor functions as an emphatic modifier, it might also modify *sine* and this, again, gives rise to a reflexive interpretation:

90. George contează pe sine însuși.
George counts on self self
“George counts on him himself”.

Note that *însuși* carries specification for number and gender features, but this is not the case of *sine*. Consequently, *sine* can be modified by *însuși* as long as the latter retains its singular, masculine (default) form (masculine is the unmarked gender in Romanian). In fact, *sine însuși* is a more constrained form. Just like *sine*, it always has to be embedded in PPs. Unlike *el însuși*, it cannot be construed with the proxy reading because it has to denote complete identity overlap with its antecedent.

The complex forms *el însuși* and *sine însuși* pattern together inasmuch as they can only sustain the bound variable reading under VP-ellipsis unlike full pronouns, which yield either the bound variable reading or the free reading (see (91) versus (92)):

91. George contează pe sine/el însuși și Alex la fel.
George counts on self/him himself and Alex too.
= George counts on George and Alex counts on Alex
*“George counts on George and Alex counts on George”.

92. George contează pe el și Alex la fel.
 George counts him and Alex too.
 = George counts on George and Alex counts on Alex
 “George counts on George and Alex counts on George”.

I will wrap up the present discussion by reinforcing a couple of clarifications. I take it that the reflexive clitic plays the part of reflexivity marker in Romanian (Romanian marks reflexivity on the verb, not on arguments like English does). The bare reflexive cannot license a reflexive reading on its own. Nor can the complex reflexive or the SE-SELF form.

The complex reflexives *sine însuși* and *el însuși* might signal that a sentence should be interpreted as reflexive, but they come with additional interpretational flavors (i.e. in most cases, with focalized readings).

5. *Concluding remarks*

To sum up so far, the Romanian anaphoric system includes the reflexive clitic *se*, its non-clitic counterpart, *sine*, as well as the complex emphatic anaphor *el însuși* and the pronominal *el*. The emphatic *însuși* could also modify the bare reflexive *sine*. *Sine însuși* and *el însuși* share one property: both of them get interpreted as bound variables. They also differ because *el însuși* has a higher degree of referential independence and it can sustain proxy readings in the relevant contexts.

I will take it that the reflexive clitic shows that the reflexivization operation has applied to a predicate in Romanian (Romanian marks reflexivity on the verb morphology, not on the internal argument, like English does). The bare reflexive cannot license a reflexive reading on its own. Nor can the emphatic forms PRON-SELF and SE-SELF. Nevertheless neither of these two are incompatible with contexts in which a reflexive reading holds.

CHAPTER 2

Clause structure

1. Preliminary

This chapter focuses on details about clause structure in Romanian. The gist of the received view is summarized below (Barbosa 1994, Cornilescu 1997, 2002 a, b, Hill 2002, Alboiu 2002 a.o)

- (i) There is one argumental subject position, Spec, *v*.
- (ii) Preverbal subjects occupy a position with A' properties, i.e. Spec, T. The T node has a dual nature. It hosts both agreement features, which are responsible for subject – verb agreement, *and* discourse-related (operator) features, which are responsible for triggering *wh*-movement and focus movement.
- (iii) V in finite clauses (indicative and subjunctive) raises to T. V does not reach C.

I concur with all the claims presented in (i) through (iii). I will strengthen the claim that the T head always has a dual nature. This implies that T will carry agreement and operator feature irrespective whether lexical items that need to satisfy a discourse-related property (say a *wh*-phrase, for instance) have been introduced in the numeration or not. Moreover, I will discuss an apparent counterexample to claim (i). This counterexample involves bare quantifiers that seem, at first blush, to occupy an argumental preverbal subject position. I will suggest instead that they should be analyzed as contrastive topics rather than subjects and that no exception to claim (i) exists.

In section 2, I will go over the various kinds of arguments that have been used to make the claim that the unmarked (basic) word order in Romanian is VSO. Section 3 discusses the consequence of accepting the configurational properties of Romanian (as outlined in section 2) for the mechanisms responsible for creating the long distance binding relationship.

62 *Clause structure*

2. *The structure of Romanian clauses*

Most of the studies that have investigated word order in Romanian converge to the conclusion that the unmarked word order must be VSO, with the subject in postverbal position and the verb raising overtly to Tense and checking the EPP feature on T. Let me briefly illustrate this point.

1. a. A citit George două cărți.
Has read George two books
“George read two books”.
- b. George a citit două cărți.
George has read two books.
- c. GEORGE a citit două cărți.
GEORGE has read two books.

The subject in (1a) gets an unmarked reading; the direct object, *două cărți*, which is the rightmost constituent carries the salient information of the sentence. The subject in (1b) has been topicalized and renders old information. The subject in (1c) has been fronted by focus movement and consequently renders the focus of the sentence.

Given that the subject, in its unmarked interpretation, stays in its theta position, I follow the mainstream claim that the Tense head does not need to project a specifier in order to have its EPP feature satisfied by movement of the external argument²³ to that respective specifier position. V raising to T takes care of the latter’s EPP feature. It follows that nominative case and ϕ -features on the subject are checked by long distance Agree. Preverbal subjects are also possible, but the mainstream claim is that they occupy an A’ position (see Dobrovie-Sorin 1994 for initial support of this claim and also Barbosa 1994, Alexiadou & Anagnostopoulou 1998, Alboiu 2002 a.o). This means that preverbal subjects will necessarily be associated with the interpretive properties that characterize

²³ We will see below that, when projected, the Spec, TP position hosts *wh*-phrases and constituents that have been focalized.

constituents that occur in the left periphery. To be more specific, preverbal subject could be topics, CLLDed phrases or focalized constituents.

Before embarking on the task to review the arguments that have been adduced to support VSO as the unmarked word order in Romanian, I will make a few brief remarks on the structure that centers around the preverbal field, summarized the in the bracketed representation below:

2. [TOPP [Topic [TP Wh-phrase/(Contrastive) Focus [T [_{VP} subject...]]]]]

Topicalized constituents are hosted in the specifier of a Topic Phrase head that represents the left periphery of the clause (see also Cornilescu 2002). *Wh*-phrases, fronted focalized constituents, fronted (preverbal) bare quantifiers (such as *nimeni* “nobody”, *nimic* “nothing”, *ceva* “something”) undergo overt movement that targets the Spec, T position²⁴. The bulk of the evidence relies on work done by Motapanyane (1995, 2001) on fronting to the preverbal focus position. She shows that focus movement targets Spec, T rather than Spec, C and conjectures, with good reason I believe, that T must be a syncretic category (see claim (ii) in the preliminary section). Let us illustrate these facts by means of a couple of examples.

(3a) includes a topicalized adverb, *mîine* (“tomorrow”) that occupies the specifier of the TopP (the adverb has been topicalized because it does not occupy its VP-adjoined position any more). *Wh*-phrases target a position lower than that allotted to topics (cf. *ce* in 3 b), and so do focalized phrases (cf. *George* in 3 c). Both *wh*-phrases and preverbal focalized constituents need to move to a specifier position that is adjacent to the T head (reference). This is exactly what happens in (3b, c).

3. a. Mîine va pilota George avionul acesta.
 Tomorrow will fly George plane.the this
 “Tomorrow George will fly this plane”.

²⁴ Motapanyane (1995) argues that the base position for subjects in Romanian is not (only) postverbal. She believes that in between the specifier of the Topic head and the specifier of Tense there has to be a third specifier, which is the argumental position for preverbal subjects.

64 *Clause structure*

- b. Mîine ce; piloteaza George ti?
Tomorrow what flies George?
“What does George fly tomorrow?”
- c. Mîine GEORGE va pilota avionul (nu colegul lui).
Tomorrow GEORGE will fly plane.the (not colleague.the his)
“Tomorrow GEORGE will fly the plane, not his colleague”.

The ungrammatical (4a, b) reinforce this adjacency restriction. In (4a) the adverb *mîine* and the *wh*-phrase, *ce*, compete for the same position, i.e. Spec, T, hence the ungrammaticality. Something similar happens in (4b), where the adverb *mîine* competes with *George*, the focalized pre-verbal constituent:

- 4. a. *Ce mîine va pilota George?
What tomorrow will fly George?
“What does George fly as a rule?”
- b. *GEORGE mîine va pilota avionul acesta.
GEORGE tomorrow will fly plane.the this
“George as a rule flies the plane”.

Romanian verbs do not raise to C (for detailed arguments against T to C in Romanian, see reference Dobrovie-Sorin 1994, Alboiu 2002, a.o). This holds not only for interrogative sentences, but for declarative one as well²⁵. As far as the Topic phrases are concerned, (5) shows that their slot is indeed the highest:

- 5. Seful a stabilit [_{CP} [_C că [_{TOPP} de regulă [_{TP} George va pilota acest avion]]]]
Boss.the has established that as a rule George will fly this plane
“The boss established that as a rule George will fly this plane”.

²⁵ This is not to say that Long Head Movement is excluded. It could apply and in those cases T does raise to C (Rivero 1994, a.o).

The tree (6) summarizes the clause structure that emerges from the data in (1) to (5)²⁶:

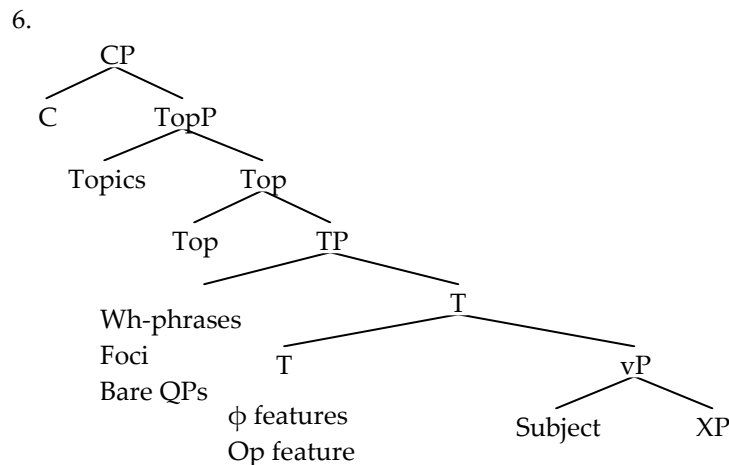

One of the interesting conclusions that emerge from tree 6 has to do with the feature make up of the T node. Under current assumptions, finite T carries a set of uninterpretable ϕ features that get checked when agreement with the subject takes place. Romanian finite T has been argued to host an additional operator feature, which is responsible for inducing movement related to discourse properties (*wh*-movement, for instance). The dual nature of the finite T head does not come as a complete surprise in the light of Chomsky's (2005) recent proposal that T closely relates to the C that takes TP as its complement. If C is a complementizer of the English *that* type, then T will be of the non-deficient type (contrast it with T in an infinitival clause). Given this association between T and C, it is quite conceivable to say that T (partly) inherits the feature make up of C. Consequently, both the agreement and the operator feature show up on both functional heads. I will pick up on this issue in section 4.

²⁶ Cornilescu 2002 argues for the existence of another specifier position in between Spec, Top and Spec, TP, a position that hosts CLLD-ed objects. She assumes a movement analysis for CLLD based on the fact that, at least in Romanian, CLLD-ed objects are ungrammatical when extracted out of islands.

2.1. Evidence to support the VSO order

The structure in tree 6 shows that Romanian subjects do not need to move from their external merge position to satisfy an EPP feature located in T. This characteristic toes the line with the Romance pattern (Spanish, Italian have postverbal subjects) and contrasts with the case of Germanic languages.

Both distributional and interpretational evidence has been brought to build up the claim that the argumental position for subjects in Romanian is located VP-internally, i.e. Spec *v*, not Spec T. I will review the relevant evidence, but before proceeding with that task, I would like to highlight a few consequences that follow from the claim that Romanian subjects stay in situ. First, it will always be the case that preverbal subjects occupy the same position as phrases that have moved to the left periphery of the clause. Second, preverbal subjects should be impossible when *wh*-movement has applied because there will be one specifier position, Spec, T, that will have to accommodate two competing phrases, i.e. the subject and the *wh*-phrase. Section 2.1.1 will tackle these issues at length.

2.1.1. Distributional evidence

First, it has been noted that preverbal subjects in Romance languages like Spanish, Catalan and Romanian have the same distribution as left dislocated objects and topicalized adverbs (Barbosa 1994, Vallduví 1995 etc). This section will enlarge on the similarity between preverbal subjects and topicalized material and will draw mainly on Dobrovie-Sorin 1994 and Barbosa 1994. The bulk of the evidence comes from the constituency in subjunctive clauses because Romanian subjunctives project a CP layer only when the need to host left periphery phrases arises. This predicts that a connection between the existence of preverbal subjects and the projection of the CP layer must hold.

Romanian has two types of subjunctive clauses, the bare subjunctive, which is marked only by the mood particle *să*, and the subjunctive introduced by the prepositional complementizer *ca*. Barbosa (1994), following Dobrovie-

Sorin (1994), notes that the mood particle *să*²⁷ clusters up with the verbal complex (which has reached Tense) because there is not much material that can intervene between the subjunctive particle and the verb. That is, only few adverbial clitics such as *mai* (once again), *și* (as well, on top of), pronominal clitics and the negation *nu* (not) break up the adjacency of the two. I have used italic characters to highlight them in 8 a - d. Tree (7 a) indicates the position of the adverbs (under Dobrovie's assumptions that they are, in fact, clitics I represented them as heads rather than phrases). Tree (7 b) presents the position of pronominal clitics and negation with respect to the subjunctive T.

7. a.

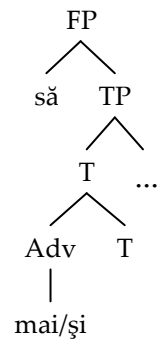

b.

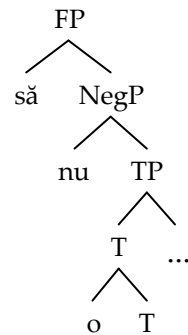

²⁷ The status of *să* does not seem to be very clear-cut because this mood marking particle has both the properties of an inflectional element and those of a complementizer (see Dobrovie-Sorin 1994 for details on this particular issue).

68 Clause structure

8. a. Incearcă să *mai* cînte.
Tries.he să_{SUBJ} once again sing.he
“He is trying to sing once again”.
- b. Vrea să *și* voteze.
Wants.he să_{SUBJ} as well vote.he
“He wants to vote as well”.
- c. A sugerat să *o* voteze Alex.
Has suggested.he să_{SUBJ} her_{CL.ACC} vote Alex
“He suggested that Alex vote her”.
- d. A sugerat să *nu o* voteze Alex.
Has suggested.he să_{SUBJ}not her_{CL.ACC} vote Alex
“He suggested that Alex not vote her”.

The complementizer *ca* is projected whenever there is left dislocated material in the left periphery of the subjunctive clause, as is the case in (9a), where *în fiecare zi* “every day” occupies the Spec, Top position²⁸.

9. a. Vecina mea vrea [CP_{ca} [TOPP *în fiecare zi* [TP [T să vina
[vP instalatorul]]]]].
Neighbor.the mine wants that in every day să_{SUBJ} come
plumber.the
“My neighbor wants the plumber to come every day”.
- b. ??Vecina mea vrea [CP *ca* [TP să vină [vP instalatorul în fiecare
zi]]].
Neighbor.the mine wants that să_{SUBJ} come plumber.the in every
day

²⁸ Note however that, to my ear 9 b, where no left dislocation has taken place, does not sound completely ungrammatical; the sentence deviates from the requirements imposed by standard language.

- c. Vecina mea vrea [TP [T să vina [vP instalatorul în fiecare zi]]].
Neighbor.the mine wants să_{SUBJ} come plumber.the in every day

Examples 10 a-c below, all involving *ca* subjunctive subordinates, neatly demonstrate that preverbal subjects (*George* in 10 a) occupy the same slot as topicalized adverbs (*mîine* in 10 b) and left dislocated objects (*pe George* in 10 c). Again, for convenience, I highlighted by means of italics all the constituents whose distribution patterns similarly:

10. a. Am cerut [C ca [TP *George* [T să repare [mașina]]]].
Have.I demanded that *George* să_{SUBJ} repair car.the
“I demanded that *George* repair the car”.
- b. Am cerut [C ca [TOPP *mîine* [TP să primesc documentele necesare]]].
Have.I demanded that tomorrow să_{SUBJ} get.I documents.the necessary.
“I demanded that I get the necessary documents tomorrow”.
- c. Am cerut [C ca [TOPP *pe George* [TP să-l interogheze agentul M]]].
Have.I demanded that on *George*_{ACC} să_{SUBJ} him_{CL.ACC} interrogate agent M
“I demanded that agent M interrogate *George*”.

Second, it is worth taking a close look at the placement of preverbal subjects with respect to *wh*-phrases and focalized constituents (Barbosa, Vallduví). Since they are topicalized, one expects them to sit above *wh*-phrases and foci, which, as I have just mentioned above, target the Spec, T position. Indeed they do, as schematically shown in (11 b):

11. a. Băiatul blond ce a băut?
Boy.the blond what_i has drunk t_i?
“What did the blond boy drink?”

70 Clause structure

- b. [TopP Băiatul blond [Top [TP ce [T a [vP baut <ce>]]]]?
Blonde boy what has.he drunk <what>

Moreover, no additional material can intervene between the verb that has raised to Tense and *wh*-phrases. See (12 a), in which nothing interrupts the adjacency between the *wh*-phrase and the Tense node as opposed to the offending (12 b), with the intervening topicalized adverb *acum* (“now”) or (12c) with intervening focalized constituents.

12. a. [TP Ce [T spune [vP George acum]]]?
What says George now?
“What is George saying now?”
- b. *[TP Ce [TopP acum [T spune [vP George]]]]?
What now says George
“What is George saying now?”
- c. (Ieri) CARTILE (*ieri/*cineva) le-a
Yesterday books.the (yesterday/somebody them_{CL.ACC} has
cumpărat, nu dosarele.
bought, not binders.the
“It was the books that somebody bought (yesterday), not the
binders”.

If the subject in (12 b) had been preverbal, as it is in (13) below, ungrammaticality would arise, which goes again to show that, distributionally, preverbal subjects behave as non-argumental phrases, i.e. topics:

13. *[TP Ce [TP George [TopP ieri [TP a auzit]]]]?
What George yesterday has heard?
“What did George hear yesterday?”

Moreover, the ungrammaticality of (13) finds a straightforward explanation if we are willing to believe that the *wh*-phrase and the preverbal subject compete for the same position, an A' one. This fact gives more weight to the claim that Spec, T in a language like Romanian cannot be characterized as an A-position.

As expected, Spec TopP can be reiterated, it is a recursive position, but that is not the case for Spec, T. This falls in line with the fact that there is no limit to topicalized constituents in a sentence, but the number of focalized ones cannot exceed one (Rizzi 1997):

Recursive/multiple topics

14. Ieri, pe neașteptate, George a insultat-o pe Maria.
 Yesterday, unexpectedly, George has insulted her_{CL.ACC} on Maria
 “Yesterday, unexpectedly, George insulted Maria”.

2.1.2. Interpretational evidence

The interpretational evidence regarding preverbal subjects focuses on two important aspects. First, it is quite a robust generalization that the phrases that occupy Spec, T show restricted interpretive properties. Second, data involving scope with quantified preverbal subjects points to the conclusion that those subjects have different scopal properties than postverbal subjects (Alexiadou & Anagnostopoulou 1998).

Alboiu 2002, while discussing the fact that Romanian has free word order and accepts any possible combination of subject, verb, object²⁹, notes that (i) preverbal subjects either bear contrastive stress or (ii) have to be interpreted as specific. Therefore the preverbal subject position hosts only contrastively focalized phrases or specific/referential ones, i.e. definite DPs, referential indefinite DPs, partitive indefinite DPs, generic collective DPs. The examples in (15) are cited from Alboiu 2002 and they illustrate all these kinds of preverbal subjects.

15. a. *Prietena mea* a obținut o bursă în Franța. Definite DP
 Friend.the my has obtained a fellowship in France
 “My friend got a fellowship in France”.
- b. *O prietenă de-a mea* e lingvистă. Referential indefinite DP
 A friend of my_{GEN} is linguist
 “A friend of mine is a linguist”.

²⁹ SVO, VSO, VOS, OVS, SOV, OSV.

72 Clause structure

- c. *Doi pești sînt negri, al treilea e roșu.* Partitive DP
 Two fish are black, the third is red
 “Two fish are black (the third is red)”.
- d. *Trei pești sînt mai scumpi decît doi.* Generic collective DP
 Three fish are more expensive than two
 “Three fish are more expensive than two”.

A few words about bare quantifiers and non-referential quantified DPs in preverbal position are in order at this point. As expected, they cannot surface in the topic position (Alboiu 2002, Cornilescu 2002, Dobrovie-Sorin 1994, Motapanyane 1994), as shown in the examples below with topicalized objects, quoted from Hill 2002:

16. a. *(Pe) mulți copii Maria (i)-a invitat t la aniversare.
 On many kids Maria them_{CL.ACC} has invited to birthday
 “Many kids Maria has invited to the party”.
- b. **Pe cineva Maria (l)-a invitat la aniversare.
 On somebody Maria him_{CL.ACC} has invited to birthday
 “Somebody Maria has invited to the party”.

Whenever bare quantifiers and non-referential quantified DPs surface in preverbal position, the prediction would be that these quantifiers occupy the specifier position that is immediately adjacent to T, i.e. Spec T³⁰:

³⁰ This prediction can be tested by checking whether a *wh*-phrase can occur as well in (17) as a result of *wh*-movement. If there is indeed just one specifier position above T that is targeted by A'-movement, then such a sentence should be ungrammatical because the bare quantifier ends up in complementary distribution with the *wh*-phrase. However, as (1) shows, no ungrammaticality follows.

- (1) a. Cineva ce a furat?
 Somebody what has stolen?
- b. Mulți ce aluzii au facut?
 Many what allusion have made?

Note that an approach á la Cornilescu (2002) (see footnote 25), which extends the Romanian left periphery by one more specifier position that hosts moved CLLD-ed

17. a. Cineva a furat pisica vecinului.
Somebody has stolen cat.the (of) neighbor.the_{GEN}
“Somebody stole the neighbor’s cat”.
- b. Mulți au înțeles aluzia.
Many have understood hint.the
“Many understood the hint”.

Barbosa suggests bare quantifiers and non-referential quantified DPs end up in the preverbal field as a result of A bar movement, i.e. focalization.

The specificity requirement that goes along with preverbal subjects that have not been contrastively stressed hints, yet again, at the conclusion that they are, in fact, topics.

Observe that Alexiadou & Anagnostopoulou 1998 also draw on arguments related to interpretational effects to better flesh out the claim that preverbal subjects in Romance null subject languages such as Spanish and Romanian must be CLLD-ed constituents rather than true subjects (like those in English). Starting from Greek data, they note that quantified subjects in the preverbal position are only associated with wide scope over quantified direct objects, whereas postverbal subject quantifiers can have either narrow or wide scope with respect to the direct object. Since movement to an argumental position preserves the scopal properties of quantifiers, the authors are inclined to conclude that the preverbal subjects cannot be argumental.

Romanian replicates the same scope-related phenomenon:

18. Cîțiva elefanți au sfidat toți șoarecii.
A few elephants have defied all mice.the
“A few elephants defied all the mice”.
19. Au sfidat cîțiva elefanți toți șoarecii.
Have defied a few elephants all mice.the
“A few elephants defied all the mice”.

objects, cannot capture the precise position of the bare Q in (1) either. I will have a closer look at examples similar to (i) in section 2.2 and propose that quantifiers like *cineva*, *mulți* function as contrastive topics.

74 *Clause structure*

The quantified subject in (18) can only be interpreted as having wide scope over the direct object, i.e. a certain group of elephants defied all the mice; the narrow scope reading according to which for each mouse there are different elephants that defied him does not come too readily to mind. However, it does represent a plausible option in (19), where the indefinite postverbal subject shows scopal ambiguity with respect to the direct object.

In addition, Alexiadou & Anagnostopoulou argue that indefinite preverbal subjects are usually given the strong/specific interpretation, while postverbal ones go for the weak existential interpretation. Bearing in mind that the existential interpretation arises as the result of existential closure, which takes place at the VP level, once more it looks like preverbal subjects must have left their initial, VP-internal position precisely because they lend themselves a specific interpretation.

Again, when preverbal, Romanian indefinite subjects get the specific reading, and, when postverbal, favor the existential reading, though I would not dismiss the possibility that, in (20 b), it is a certain elephant that defied *Mickey*:

20. a. Un elefant l-a sfidat pe Mickey.
An elephant him_{CL.ACC} has defied on Mickey_{ACC}
- b. L-a sfidat un elefant pe Mickey.
Him_{CL.ACC} has defied an elephant on Mickey_{ACC}
“An elephant defied Mickey”.

2.2. A stumbling block

In this short section I will play the devil’s advocate and look at one argument that might pose a challenge to a theory that takes VSO as the unmarked word order for Romanian.

Hill 2002 claims that there has to be an argumental subject position in the preverbal position. Its location is in between the specifier projected by the Topic head and the specifier of T, which hosts *wh*-phrases and foci. She gives the following example, which is represented in (22) below:

21. Intr-o bună zi cineva TOATE PROSTIILE astea o să le scoată la iveală.
 In one good day somebody all stupidities.the these will să_{SUBJ} them bring to light
 “One day, somebody will bring all this crap to light”.

22.

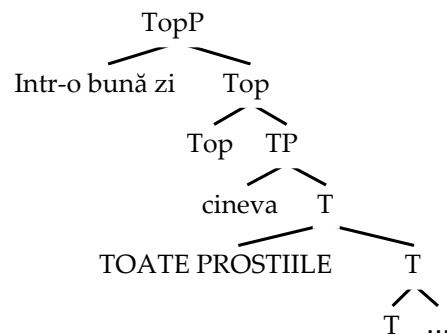

Cineva (somebody), a bare quantifier, cannot be a topic, since it is not referential. It cannot be focalized either, since the phrase *toate prostiile* (all stupidities) occupies the focus position. By elimination, Hill concludes that it has to be the preverbal subject of the sentence that is occupying an A-position. She offers more examples, like (23).

23. Nimeni NIMIC nu ți-ar face fără pile.
 Nobody nothing not you_{DAT} would do without connections
 “There’s nothing anyone would do for you if you don’t have connections”.

Nimeni (nobody) instantiates another case of a bare quantifier that occupies the preverbal subject position and cannot function as a focus. The conclusion will be, again, that it must be the subject of the sentence.

I would like to pursue an alternative explanation for the status of both *cineva* in (21) or *nimeni* in (23) and suggest that they are in fact contrastive topics. It has been argued (Gyuris 2002, a.o.) that, for Hungarian, contrastive topics differ from standard topics because they fail to pass the topichood tests, i.e. the

76 Clause structure

referentiality and the aboutness tests. First, the standard condition that topics must meet is referentiality. Topics denote individuals that should be familiar from discourse (hence the association of old information or givenness with topics). The topic in (24 a), *pe Ion*, is a referential DP of whom a property is predicated. The topic in (24 b), *nimeni*, is a bare quantifier, which is non-referential. As a consequence, (24 b) is an ill-formed sentence

24. a. Pe Ion l-am intilnit anul trecut.
On Ion him_{CL.ACC} have.I met year.the last
“John, I met him last year”.
- b. *Nimeni, Maria nu l-a vazut.
Nobody Maria not him_{CL.ACC} has seen
“Nobody, Maria saw”.

Second, the individuals that topics denote are considered entities of which a certain property is predicated (i.e. topics convey what a sentence is about).

Gyuris shows that non-referential expressions such as universal quantifiers, distributive quantifiers, existential quantifiers could be contrastive topics even if, as shown in (24), they cannot be standard topics. I will cite only one of her Hungarian examples below (CT stands for contrastive topic)

25. [CT Mindenki] nem jött meg.
Everybody not came_{PEX}
“It is not the case that EVERYBODY arrived.”

Moreover, she notes that not only quantified expressions, but also Hungarian infinitivals and adjectives in nominal predicates function as contrastive topics.

26. a. Péter [CT enni] evett. Infinitive contrastive topic
Peter eat-INF ate_{3SG}
“As for eating, Peter did eat.”
- b. A film [CT jónak] jó. AP contrastive topic
The movie good_{DAT} good
“As for being good, the movie is good”.

It will be impossible to think of infinitivals and adjectives in nominal predicates in terms of individuals that denote entities and, yet, as (25) and (26) show, both of them could be contrastive topics. If contrastive topics do not have to denote a referential, previously identified individual, then bare quantifiers like *cineva* and *nimeni* could also do this job.

Quite interestingly, Gyuris proposes that contrastive topics go hand in hand with what she calls “an associate”. The presence of the associate ties in closely with the nature of contrastive topics because “... *the contrastive topic construction requires that certain presuppositions regarding the structure of the preceding discourse be satisfied, and it also introduces an implicature of contrast*” (Gyuris 2002: 41). The associate may be realized by the focus of the sentence (for details on other possibilities to realize it, see Gyuris, Chapter 3). Going back to (21) and (23), one could not help noticing that both are constructed on the same mould, i.e. the bare quantifier that realizes the contrastive topic comes first and is followed by a focalized preverbal constituent. It is quite conceivable that those focalized constituents play the role of the afore-mentioned associate.

I would like to end this section by underlining the conclusion that for the apparent counter-examples to the subject in situ hypothesis, such as (21) and (23), an alternative account is available. In the light of this account, the position that there is no preverbal argumental subject position in Romanian can be maintained. Moreover, note that this gives us another advantage. If two subject positions, preverbal and postverbal would indeed be available, optionality rears its ugly head and the first obvious question that needs an answer concerns the exact motivation for movement of the subject to the preverbal position. The reason cannot be case, because nothing prevents this bare quantifier from checking case in its initial merge position, hence, (27), with the subject in situ, is perfectly acceptable:

27. Intr-o bună zi TOATE PROSTIILE astea cineva o să le scoată la iveală.
 In one good day somebody all stupidities.the these will să_{SUBJ} them
 bring to light

Our conclusion is then that this problem does not arise.

3. *Summary*

In the first two sections of this chapter I have gone over the various kinds of arguments that have been used to make the claim that the unmarked (basic) word order in Romanian is VSO. All in all, I believe that the distributional and interpretational evidence that point to the fact that preverbal subjects behave similarly to left dislocated material is quite convincing (with the caveats that I have pointed out in section 2.2).

4. *Consequences*

The most important consequence of accepting the configuration in (6) as the phrase structure template in Romanian has to do with the status of the Tense node. Tense in Romanian is a functional category with heterogeneous properties. On the one hand, as expected, it represents the locus of agreement with the subject and the functional head responsible for nominative case checking. On the other, it may have a [+wh] feature that triggers movement of *wh*-phrases to its specifier position. Also, as previously mentioned and exemplified, its specifier hosts focalized constituents that move out of their initial merge position. This ultimately means that Tense has also the type of operator properties that lead to the formation of A'-dependencies. Chomsky 2005 suggests that there is a deep-seated connection between Tense and the complementizer head that takes TP as complement, because the Tense will be in its finite or, respectively, non-finite form function of the type of C. Taking this association a bit further, it is quite plausible to consider that Tense inherits its agreement and finite/non-finite dimension from C.

The work on focus and *wh*-movement by Hill and Alboiu consider fronting to the preverbal focus position as well as *wh*-movement to result from features that are parasitic on the highest TP head that has been merged in the derivation. Usually, the highest head in the verbal inflection field is Tense.

The mechanism responsible for creating the long distance binding relationship that constitutes the main concern of the present dissertation also partly draws on the consequences of the connection between Tense and complementizer, as I will briefly point out. I would like to argue that the long distance interpretation arises as the result of the reflexive anaphor *sine* satisfying

a double requirement: (1) it should agree in person and number with the local (and long distance) subject and (2) it should check an operator feature that is morphologically encoded on it, and sensitive to the presence of the syncretic T-node in Romanian. The operator feature in T attracts the reflexive anaphor out of the lower v^* phase and makes it visible for further computation.

Given what I have outlined above, the time has come to make a couple of detailed clarifications regarding a few not so obvious theoretical framework issues. On the whole, I will go along with the minimalist program as outlined in Chomsky 2004 and 2005, but, at some point of my analysis, the issue becomes relevant whether Agree, understood as long distance agreement between a probe and a goal that involves no movement at all, replaces covert movement (Chomsky's 1995 Move F).

I will be relying on feature movement/Agree to account for the particular long distance binding data in Romanian. Therefore, I will devote some time to reviewing the status of covert movement in the minimalist program, starting with the arguments that have been brought in *Minimalist Inquiries* (MI) and *Derivation by Phase* (DbP) to support the idea that this kind of movement does not represent a virtually necessary concept and should be therefore discarded. The reasons that motivate this conclusion are quite varied and I will briefly mention them in what follows.

First, the necessity of holding on to the concept of covert movement has been called into question once the idea that a single spell-out point exists has been dropped. Due to considerations of optimal design specifications, the minimalist program has opted for the possibility that multiple spell-out points are set throughout the derivation. First of all, this falls in line with the way phases work: once a phase has been completed and all the uninterpretable features within it have been checked, spell-out applies and takes the respective phase away from the working space. Second, and also most important, multiple spell-out points eliminate the unnecessary second cycle within which post spell-out operations (i.e. covert LF operations) were supposed to take place in the Chomsky 1995 framework. Given that, until proven otherwise, language functions according to the principle *less is better*, the conclusion that syntactic operations have to take place within one cycle can only be a welcome language-architectural simplification. Apart from Merge, those syntactic operations are (i) Agree, which results in long-distance agreement relations and does not involve

80 *Clause structure*

any movement and (ii) Move, which is a composite of Agree and pied-piping (note that for movement to apply, Agree has to be established first).

Second, more technical considerations come into the picture as well. In Chomsky 2004:115, the ban on feature movement finds motivation inasmuch as it is conceived as a means to comply with the No Tampering Condition (NTC), which requires that the feature make-ups of lexical items should not be altered in the course of derivations (nor should this happen to basic relations such as c-command and sisterhood). Following this line of reasoning, features that move and attach to lexical items, will cause modifications within the respective lexical items and this ultimately does not count as a desirable outcome.

Moreover, Chomsky 2000: 119 notices difficulties related to the task of defining chains created by features, on the assumption that movement of features or sets of them does occur. More precisely, he brings up the problem of the way in which occurrences of features could be identified.

Taking into account both the above-mentioned optimal design specification reason as well as the technical impediments, MI and DbP have replaced Move F with Agree.

Chomsky 2004, on the other hand, ushers back in the overt/covert distinction by allowing for internal merge to take place either before or after spell-out (which he calls TRANSFER). In the first case, internal merge results in overt movement; in the latter it produces covert movement. One of the differences between the two lies in the place where copies are pronounced (movement causes a copy of the moved item to be left behind). With overt movement, the highest copy gets pronounced; with covert one, it is the lower copy that gets spelled-out. The second difference is that Agree precedes overt movement, but it does not induce in any way covert movement, so to speak, because it applies only before TRANSFER.

I will adopt the standard assumptions with regard to the way derivations proceed within the computational system, i.e. narrow syntax.

First, the presence of uninterpretable features on categories that can function as probes enable these to search within a limited, local domain for a Goal with matching suitable interpretable features. The Goal itself must bear an uninterpretable feature to become active for a Probe to spot it out. Usually, it is the case feature on (nominal) goals that activates them, but, since I endorse the view that Romanian DPs do not move for case reasons (see Alboiu 2002 for detailed arguments), I will resort to a different type of uninterpretable feature

that triggers movement, i.e. the operator feature that is associated with synthetic Tense in Romanian.

Second, derivations go on by phase, with v^* and CP counting as phases. It is not possible for an item to get out of a phase unless it has previously moved to the edge of that phase, because, in accordance to the Phase Impenetrability Constraint (PIC), only the edge of a phase and its head could be accessible for further computation, if need be, but not the complement of the respective head. More precisely, let us take the following configuration (from DbP), with HP the lower phase and ZP the upper one:

28. [ZP ... [HP a [H YP]]]

According to PIC, only H and the specifier it projects, *a*, are visible for probes in the upper phase. YP, the complement of H, does not count as visible because it has been already spelled-out.

Third, a close connection exists between the complementizer head and the Tense of the respective C head selects (Chomsky 2004, 2005). To illustrate this with an example for Romanian, the complementizer *că* (*that*) selects an embedded clause with finite, Tense. This selection ensures that, in this case, the selected Tense is ϕ complete and, consequently, will agree with the embedded subject and check its nominative uninterpretable feature. Note that this ultimately means that *C-T are really functioning as an unit in inducing agreement* (Chomsky2004:116).

CHAPTER 3

Non-local binding and the Blocking Effect

1. *Levels of dependency encoding: from syntax via semantics to discourse*

1.1. **Introductory remarks**

One and the same anaphoric form may take on different usages. For instance, the third person singular English reflexive pronoun *himself* occurs with reflexive predicates to yield a reflexive interpretation, as in (1).

1. George_i hates himself_i.

Himself, however, ceases to be associated with a reflexivizing interpretation if it does not occur as the argument of a reflexive predicate, in (2), from Pollard & Sag (1992).

2. Jessie_i knew full well that the local people would all feel that [people like himself_i] were not to be trusted, let alone hired.

The intrinsic morpho-syntactic properties that an anaphoric form has will allow it to take on a precise set of usages. These intrinsic properties include the anaphor's syntactic distribution and the feature specification of its constituting parts (in case it is morphologically decomposable). More precisely, the ϕ feature set that anaphoric forms carry, and which determine their [\pm R] status, as well as their specification for the [\pm reflexive marker] feature, will partly decide how they are used. With these details in mind, let us go back to (1) and (2). *Himself* in (1) contributes to licensing the reflexive interpretation of the predicate *hate* because it is an anaphor that has the [+reflexive marker] feature. Its [+reflexive marker] property does not make any difference for (2), where the coindexed elements, *Jessie* and *himself*, are not co-arguments of the same predicate. The felicitous usage of *himself* in (2) depends on another factor, i.e. whether its antecedent reports on a state of affairs of which he / she is aware (as

84 *Non-local binding and the Blocking Effect*

the main protagonist). This makes *himself* in (2) take on its logophor usage (see section 1.2.1 for details on logophoricity).

Let me go through other examples in order to further support the point that I have made about (1) and (2). I will draw on data from Dutch and Norwegian.

Dutch *zichzelf* is the [+reflexive marker] anaphor and it licenses reflexive predicates (cf. 3)

- 3. a. Jan_i haat zichzelf.
Jan hates himself
- b. *Jan_i haat zich_i.
*Jan hates self

Outside the co-argument domain, *zich* may be used.

- 4. Oscar_i voelde [zich_i wegglijden].
Oscar felt self slide away

Norwegian *seg selv* carries the [+reflexive marker] feature. Its use with reflexive predicate follows. The bare reflexive *seg* is used non-locally. Moreover, the non-local use goes through only if the bare reflexive is subject oriented (cf 5 b versus 5 c)).

- 5. a. Jon_i foraktet seg selv_i/*seg_i
Jon despises himself/*self
- b. Jon_i bad oss snakke om seg_i
Jon asked us to talk_{KINF} about SE.
- c. *Jeg lovet Jon_i å vaske seg_i
I promised Jon to wash himself

So far, it can be concluded that those anaphoric forms that do not carry the feature [+reflexive marker] and do not occur as co-arguments of a reflexive predicate share a distributional property: they may enter non-local

dependencies with their antecedents (see Icelandic *sig*, which I have not mentioned yet, Dutch *zich* and Norwegian *seg*). Since non-local binding will be in the spotlight of the present dissertation, let us have a look at the properties that characterize non-local antecedent – anaphor relations. Two quite obvious observations come immediately to attention. As example (5c) illustrates, the antecedent must be the subject. Second, the antecedents must c-command the respective anaphoric forms. I will take subject-orientation and c-command to be the hallmark of non-local antecedent – anaphor dependencies. The next issue to broach concerns the definition of the term *non-local*. I will have more to say about this in section 1.2³¹.

Bear in mind two facts, however. First, the possibility of entering into non-local binding dependencies is not only a matter of anaphor type. The type of embedded clause, which contains the non-local anaphors, also counts. More precisely, the pair in (6) shows that, in Icelandic, being embedded in a subjunctive clause is also a relevant feature for the non-local relation to go through. When *sig* is contained in an indicative clause, it cannot link up to a non-local antecedent (cf. 6 b).

6. a. Jon_i segir að Petur_j raki sig_{i,j} a hverjum deg
Jon says that Peter shaves_{SUBJ} sig every day.
- b. *Jon_i veit að þu hefur svikið sig_i
John knows that you have betrayed_{IND} self

Second, there are instances of non-local dependencies that do not involve subject-orientation (7 a) and c-command (7 b). Moreover, in languages other than Icelandic, these non-local dependencies do not need to start only out of subjunctive clauses (8). English is an example of such a language:

³¹ I left the Dutch case out of the discussion because the use of *zich* in non-local dependencies is more restricted than the use of its Icelandic and Norwegian counterparts. Dutch only allows non-local binding into small clauses and perception verb complements (see Everaert 1986 and Reinhart and Reuland 1991 for discussion).

86 *Non-local binding and the Blocking Effect*

7. a. Mary heard from John_i that an obscene paper supposedly written by Ann and himself_i was being circulated.
(Zribi-Hertz 1989)
- b. The picture of himself_i in Newsweek dominated John_i's thoughts.
(Pollard & Sag 1992)

The anaphors in (7) (but also that in (6 a)) can be interpreted long distance only if they relate to antecedents that are discourse salient. *Himself* in (7 a) relates to a prepositional object antecedent. In terms of discourse organization, the prepositional object is more salient than the subject because its referent is the source of what is being said. *Himself* in (7 b) is embedded in the subject constituent. As such, it is not c-commanded by its antecedent, *John*. The crucial point about (7 b) is that *John* takes on the role of perspective holder in discourse and presents a certain state of affairs from his personal point of view. The perspective holder part that the antecedent assumes crucially licenses the use of *himself* in these cases, as the next example, (8) illustrates:

8. *Mary was quite taken aback by the publicity John_i was receiving. That picture of himself_i in the paper had really annoyed her, and there was not much she could do about it.

Mary is the perspective holder here because a certain state of affairs, i.e. that the publicity *John* gets upsets her, is reported from her own point of view. However, *himself* does not link up to *Mary*, but to *John* and the result is ungrammatical. Note that, cross-linguistically, both bare reflexives and SELF-anaphors, i.e. the *himself* type, can take on the logophoric usage. The morphological form of the anaphor does not matter in this respect. Only the requirement that the antecedent be the perspective holder does.

So far, a few properties claim their right to define non-local anaphor – antecedent dependencies: subject – orientation, c-command and discourse saliency of the antecedent. The first two are structural properties; the last one has to do with discourse. To keep matters clear, I would like to draw a separating line between the non-local dependency illustrated in (5 b), on one hand, and those illustrated in (6 a) and (7 a, b). Subject-orientation and c-commanding antecedents define the first type. The requirement that antecedents

play the part of perspective holders in discourse characterizes the second type. I will argue later that the first type instantiates a dependency that can be reducible to computation in syntax. The latter cannot be captured by a structural binding configuration and works function of discourse considerations.

Let me sum up this informal introduction with a few relevant concluding remarks. So far, I have claimed that one and same anaphoric form may have different usages, depending on the position it occupies in the sentence and on the intrinsic properties it has. Generally speaking, a strong correlation holds between the intrinsic properties of an anaphoric form and the usages it will take in the sense that the former determine the latter. Anaphoric forms that have the property of being [+ reflexive marker] and occur in the co-argument domain of a reflexive predicate are used to license reflexive readings. Outside the co-argument domain, the same anaphors may take on the logophoric usage, if the right (discourse) conditions are met. I illustrated that with English *himself*. Anaphoric forms that do not bear the [+ reflexive marker] feature may enter non-local dependencies. Non-local dependencies, in their turn, come in two flavors. Those that involve anaphors that require subject-orientation and c-commanding antecedents and those that impose discourse conditions on the antecedent. I refer to the first type of anaphor by the term Non-Local Anaphor, NLA. The second type instantiates logophors.

A more in-depth presentation of non-local anaphors and logophors will constitute the focus of the next section.

1.2. The notion of “non-local anaphor”

This section will concentrate on fleshing out the notion of non-local anaphor. I take non-local anaphors, henceforth NLAs, to be anaphors that are not locally bound. I understand non-local binding in terms of the possibility for an anaphor to be bound in violation of the Specified Subject Condition, henceforth the SSC (Chomsky 1973). The SSC maintains that no syntactic operation can involve X and Y in the following configuration, where Z is the subject in the α projection (which can be realized either as a full DP or as a non-anaphoric pronoun). Chomsky maintained at the time that not only clausal structures have subjects, but also maximal projections such as NPs.

88 *Non-local binding and the Blocking Effect*

9. ... X ... [_α...Z ... -WYV ...] ...

One of the grammaticality contrasts that the SSC accounts for is shown in (10) below:

10. a. The men_i saw [_{NP} the pictures of each other_i].
b. *The men_i saw [_{NP} John's picture of each other_i].

Remember from Chapter 1 that reciprocal pronouns count as anaphors that need to be locally bound (in the Chomsky 1981 sense). In the GB framework, local binding requires that the anaphor should be in a domain that includes its governor and an accessible SUBJECT, which could be (i) the subject itself or (ii) the agreement, the AGR node. The NP in (10 a) does not have a specified (overt) subject, so the clause subject, *the men*, counts as an accessible SUBJECT for the reciprocal *each other*, which ends up being bound within the main clause rather than the NP domain. Matters are quite different in (10b) because the NP has a specified subject, the possessive *John's*, and binding of the reciprocal by the matrix subject, *the men*, cannot go across that NP subject. Consequently, *each other* should have been bound within the NP, not at the level of the entire clause (hence the ungrammaticality of the sentence).

As already mentioned at the end of section 1.1, the non-locality in terms of binding that NLAs display is, in fact, reducible to a structural binding configuration. This amounts to saying that I use the notion of NLA as a purely descriptive term. The fact that NLAs contract dependencies that can be narrowed down to a structural binding configuration makes them different from logophors. I will take subject orientation and c-command to be two of the properties that define NLAs as a distinct class. The third property is the sloppy reading in VP-ellipsis contexts, and I will discuss it later on.

In what follows I will contrast NLAs to logophors. I believe it is worth setting up this contrast so as to be as clear as possible why NLAs should not be mistaken for logophors (or the other way round).

1.2.1. Logophoric pronouns

The term logophor was introduced in Hagège (1974) to describe a type of pronoun with specific referential properties. Logophoric pronouns are

employed in order to “*distinguish reference to the individual whose speech, thoughts or feelings are reported or reflected in a given linguistic context from reference to other individuals*” (Clements 1975: 141). Logophoric pronouns make up special pronominal paradigms (*special* in the sense that they are distinct from the paradigm of reflexive and personal pronouns). Some African languages have these additional pronominal paradigms: Mundang, Tuburi, Ewe, Yoruba, Gokana a.o. (see Hagège 1974, Clements 1975 a.o.). It is generally acknowledged that logophoric pronouns are employed whenever the subject or the speaker wants to present an event or a state of affairs as seen exclusively from his or her own perspective. Let me exemplify with the singular logophoric pronoun in Ewe, *ye* (Sells 1987)

11. a. Kofi be ye-dzo REF
 Kofi say Log-leave
 “Kofi_i said that he_i left”.
- b. Kofi be e-dzo REF
 Kofi say Pro leave
 “Kofi_i said that he_j left”.

In (11 a) the subject antecedent, *Kofi*, reports an event of leaving whose unique protagonist he is. This legitimizes the usage of the logophoric pronoun *ye* to refer back to *Kofi*. In (11 b), on the other hand, the leaving event concerns somebody else than the subject *Kofi*, and a (null) pronoun is employed to formally mark this.

Logophors are characterized by a mix of formal and discourse properties. The formal ones include (i) a restriction on the classes of predicates that take subordinate clauses with logophors and (ii) a restriction on the complementizers that introduce subordinates with logophors. The verbs that take clauses with logophoric pronouns fall into a couple of limited classes, i.e. verbs of communication, psych verbs and (mental) perception verbs³². The following pair of examples shows the Ewe logophoric pronoun *ye* (plural form

³² Note that perception verbs do not always allow for logophors in their subordinate clauses (Sells 1987).

90 *Non-local binding and the Blocking Effect*

yewo) embedded in complement clauses selected by mental and physical perception verbs, *know* and *see*, respectively (Sells 1987).

12. a. Kofi_i nya be me-kpo ye_i.
 Kofi know_{COMP} pro-see_{LOG}
 “Kofi knew that I had seen him”.
- b. Kofi kpo be yewo-do go.
 Kofi see_{COMP} LOG,PLcome out
 “Kofi saw that they (including Kofi) had come out”.

Moreover, the presence of logophoric pronouns in subordinate clauses ties in with complementizer choice. Some complementizers induce logophoricity effects, whereas others do not have this property. For instance, Koopman & Sportiche 1989 discuss two classes of pronouns in Abe (a Kwa language), the *O* pronouns and the *n* pronouns. They note that *n* pronouns *prima facie* qualify as referential pronouns, but, they can also behave as logophoric pronouns. If *n* pronouns are embedded in subordinates introduced by the logophoric complementizer *kO*, then they will corefer with the DP that is the source of the report, regardless of its status as either an *O*-pronoun or a full DP. In the same structure, *O* pronouns, which are regular pronouns, will be disjoint in reference from the subject (cf. 13).

13. Yapi_i hE [kO O_j/ n_{i, (j)} ye sE].
 Yapi said kO he is handsome

When *n* pronouns occupy the subject position of a complement that is marked in a specific (tonal) way that Koopman and Sportiche equate with subjunctive, they are disjoint in reference from any full DP or *O* pronoun as shown by (14), i.e. their logophoric usage does not obtain.

14. Yapi_i kolo ye n_{j, *i} wu api.
 Yapi wants ye he see Api

Crucially, disjointness of reference holds when the respective subjunctive complements are introduced by the complementizer *ye*, which does not induce logophoricity effects (cf. 14).

The connection between the choice of complementizer and the availability of logophoric interpretation only goes to show that, at least in some West African languages, logophoricity effects do not arise solely as the result of the speaker or the subject introducing his own point of view in discourse. This, in turn, means that only discourse requirements, such as choice of a certain main verb or perspective holding antecedents cannot be invoked to be completely responsible for logophoric interpretations. Syntactic reasons are at play as well because the presence of certain complementizers in the (syntactic) derivation will influence the choice of pronoun in the clause they introduce³³.

1.2.2. Logophoric anaphors

In some Asian languages (i.e. Chinese and Japanese) and some Germanic languages (Icelandic) the distribution of bare reflexives seems to be subject to the discourse properties of their contexts of occurrence, similar to the ones just described for logophoric pronouns. For that reason, these anaphors are sometimes called logophors (following Clements 1975). Let me exemplify this for Chinese first. Example (15) indicates that Chinese *ziji* accepts to be non-locally dependent on third person antecedents, *ziji* links up to *Lisi* and *Zhangsan*, and to *Wangwu*, of course, since it is the local antecedent (Cole, Hermon and Lee 2001)

15. Zhangsan_i renwei Lisi_j zhidao Wangwu_k xihuan ziji_{i,j,k}.
 Zhangsan thinks Lisi knows Wangwu likes self
 “Zhangsan thinks Lisi knows Wangwu likes self”.

³³ There is, in fact, more evidence that the connection between complementizer choice and the presence of logophoric pronouns does exist (Hagège 1974, Sells 1987). Mundang is a language that rules out logophoric pronouns in relative clauses. Tuburi, on the other hand, does not have this restriction on its logophors. Interestingly enough, Tuburi relative clauses are introduced by the morpheme *ga*, which is a logophoric complementizer.

92 *Non-local binding and the Blocking Effect*

(16 a) shows that non-locally bound *ziji* will preferably relate to a perspective holding antecedent. The context in (16 b), by contrast, is set up in such a way as to exclude the antecedent *Zhangsan* from the perspective holder role since he was already dead by the time the sentence was uttered. Consequently, the external speaker is the perspective holder and the example is deviant (Huang and Liu 2001).

16. a. Zhangsan_i kuajiang-le changchang piping ziji_i de naxie ren_j.
Zhangsan praise^{PERF} often criticize self de those persons
“Zhangsan praised those people who criticize him a lot”.
- b. ??Zhangsan_i kuajiang-le houlai sha si ziji_i de naxie ren_j.
Zhangsan praise^{PERF} later kill die self de those persons
“Zhangsan praised those persons who later killed him”.

Moreover, observe what happens if a first person antecedent (*wo*) intervenes and sets *ziji* apart from the remote third person antecedent, *Zhangsan* as in (17) from Cole, Hermon and Lee 2001.

17. Zhangsan_i juede wo_j zai piping ziji_{i,j}.
Zhangsan think I at criticize self
“Zhangsan thinks that I am criticizing self”.

In this case, *ziji* gets confined to being dependent on the local antecedent. A discourse explanation in terms of conflicting perspectives within a single piece of discourse has been envisaged for this kind of contexts (Pan 2001, a.o)³⁴. It maintains that *ziji* can felicitously corefer with remote third person antecedents as long as a first person, which is by default associated to the speaker, does not intervene. The first person, being associated with the speaker, introduces antecedents that rate higher on the saliency scale in discourse than third person. First person can, therefore, override third person as eligible antecedents (especially with *ziji*, which is not specified for the person feature). To put it differently, first person antecedents have the property to block any

³⁴ See Cole for a syntactic analysis (i.e. in terms of LF movement).

further dependency on higher third person potential antecedents (I will return to this section 4.4 below).

The interpretation of the Icelandic bare anaphor *sig* is also sensitive to discourse factors.³⁵ It exhibits logophoric use on the condition that (i) it is contained in a subjunctive complement³⁶ and (ii) its antecedent is the perspective holder in discourse. Thráinsson (1976, 1991) and Hellan (1980, 1991) point out that only subjunctive complements that convey the point of view of the matrix subject antecedent allow for covaluation between *sig* and the respective subject. This is argued not to be the case for (18 a) with an adverbial clause whose predicate is in the subjunctive mood. Further embedding of (18a) under a verb of saying yields a grammatical result however (18b).

18. a. *Jón_i yrði glaður ef þú hjálpaðir sé_i.
 “Jon would be glad if you helped_{SUBJ} self”.
- b. Jón_i sagði að hann_i yrði glaður ef þú hjálpaðir sé_i.
 “Jon said that he would be glad if you helped_{SUBJ} self”.

1.2.3. The distinction between logophors and NLA's

Having outlined what logophoric anaphors are, I want to argue that logophors should be distinguished from NLAs in the following ways: no strict necessity for c-commanding antecedents and no restriction to just the sloppy reading under VP-ellipsis. I will illustrate all of them in the remainder of this section.

Logophors do not require strict c-command. For instance, *Jon* in (19 a) voices an opinion about his own talents, and this subjective insight on himself licenses the dependency between *Jon* and the logophor *sig* even without *Jón* c-commanding *sig* (Reuland and Sigurjonsdottir 1997).

³⁵ Icelandic does not have the kind of intervention effects noted for Chinese (17). However, this issue is orthogonal to the discussion in this section.

³⁶ I will follow Reuland & Sigurjonsdottir (1997) in assuming that *sig* embedded in subjunctive clauses behaves on a par with logophors and in contrast with *sig* embedded in infinitival complements, i.e. NLA *sig*.

94 *Non-local binding and the Blocking Effect*

19. [NP Skoðun Jóns_i] er [að sig_i vanta hæfileika].
Opinion John's is that sig_{ACC} lacks talents_{SUBJ}
"John's opinion is that he lacks talents".

Similar facts are found for Chinese (Huang and Liu 2001):

20. Zhangsan_i de jiaoao hai-le ziji.
Zhagsan de arrogance harm_{PERF} self
"Zhangsan's arrogance harmed him".

Nor do logophors require subject-orientation, as (8a) and (8b), here repeated as (21), show for English (Zribi-Hertz 1989).

21. a. Mary heard from John_i that an obscene paper supposedly
written by Ann and himself_i was being circulated.
b. The music made her_i think of her life as it seldom did; it exalted
no one as it did herself_i.

Finally, logophors in VP-ellipsis contexts have either the sloppy or the strict interpretation. See (22), from Thráinsson 1991. I will return to this point in section 4.3.

22. Jón_i sagði að þú hefðir svikið sig_i og Pétur_j gerði það líka.
Jon said that you betrayed self and Peter did so too
= Peter said that you betrayed Peter.
= Peter said that you betrayed Jon.

I believe there is enough reason to keep apart the notions of NLA and logophor. Logophors refer (i) to the special pronominal paradigms in the West African languages *and* (ii) to the bare anaphors that relate to perspective – holding antecedents, the Chinese / Icelandic case (restricted to subjunctives in Icelandic). Apart from the discourse licensing condition, logophors may require special syntactic licensing, which is noticeable (i) in the choice of complementizers that introduce clauses that contain logophors or their verb-morphology (being subjunctive) and (ii) in the choice of predicate classes that

select clauses with logophors. NLAs, on the other hand, enter interpretive dependencies that are reducible to a structural binding configuration. They require c-commanding subject antecedents. Discourse conditions do not play a role in NLA licensing. The chart below subsumes the properties of NLAs and logophors.

	NLA	Logophor
Obligatory Subject-orientation	Yes	no
Obligatory C-command	Yes	no
Obligatory sloppy reading	Yes	no
Perspective holding antecedent	No	yes

1.3. Interim conclusions (i)

I have shown that non-local antecedent – anaphor dependencies involve either NLAs or logophors. The type of non-local dependency that NLAs go into is defined by a set of properties. The type of dependency logophors enter is governed by different constraints. I have summarized the properties that characterize both types of dependencies in the chart above.

NLAs in non-local dependencies represent the focus of this dissertation. I will argue that NLAs enter a kind of dependency that instantiates a case of structural binding. The next section will discuss the status of binding theory in the latest version of the minimalist program. This presentation is intended to familiarize the reader with the theoretical framework I am going to adopt in the implementation of my argument.

2. *Binding within the Minimalist Program (Chomsky 1995 and subsequent work)*

2.1. Levels of representation (internal versus interface levels)

The question concerning the level(s) of interpretation that encodes binding relations held the interest of the GB framework and was open again with the advent of the Minimalist Program. As already discussed in Chapter 1,

one of the main goals of the minimalist program research project is to revisit and trim down to the essentials all the concepts that have been involved in explaining how human language works. The EST model, which served as the foundation of the GB framework, envisaged the organization of the language faculty (computational system of the human language, C_{HL}) in internal and interface levels of representation. D-structure and S-structure represented the language internal levels, and PF and LF are the interface levels. The minimalist program has given up on the internal levels D-structure and S-structure because, under minimalist assumptions, they lack theoretical justification. Only the interface levels, which link up C_{HL} to the Sensory – Motor, i.e. phonological system, and to the Conceptual – Intensional system, have survived. All the operations that the EST model assumed would take place at the internal levels of representation need rethinking. Binding theory finds itself in this undecided position because, under EST standard assumptions, it has been argued to apply both at S-structure and in the covert component that relates S-structure to LF (to get a very clear idea about this, see the discussion on the fourth cycle below).

2.2. Efficient computation: the five cycle versus the one cycle derivation

The EST grammatical model proposed a model of computation that departed from what the minimalist program would qualify as efficient, as I will show in detail in what follows. EST included five cycles of operations: (i) the first cycle mapped lexical items from the Lexicon onto the D-structure level, in accordance to the X-bar template; (ii) the second cycle mapped the D-structure objects onto the S-structure (by means of overt movement); (iii) the third cycle, the morphological/phonological one, mapped S-structure onto PF; (iv) the fourth cycle mapped S-structure objects onto LF (by means of covert movement) and, finally, (v) the fifth cycle mapped LF objects onto the C-I interface, where semantics operates. The ousting of the internal levels of representation brought about a simplification in terms of cycles of operations. The five cycles of the EST model have been reduced to a single one, based on the Merge operation, which comes in two flavors. The first, External Merge (EM) gives the argument structure of a predicate. The second, Internal Merge (IM) implies re-merge of a lexical item from its theta role position to a different one. Internal Merge is the

equivalent of overt movement. Its trigger relates to satisfying discourse related properties, such as checking the interrogative feature on the C head in the case of *wh*-movement, to give just one example. IM represents the only kind of movement allowed by an efficient computational system, based on a sole cycle of operations. This obviously raises questions about the status of covert movement within the minimalist model. Chomsky suggests that the operation Agree takes over the job of covert movement (see cycle (iv) above). Agree results from a Probe with unvalued features searching its complement domain to find a Goal with a matching valued feature. Agree applies when the Probe has checked its unvalued feature. Crucially, Agree is a static relation, which means that it involves no movement at all. Structure is built bottom-up in the computational system and expands until it completes a phase (*v*Ps and CPs are phases). Completed phases are taken out of the working space and stored away, i.e. completed phases get spelled-out. The material contained within a phase becomes unavailable for any syntactic operation after the spell out point. A lexical item caught up in a phase has the opportunity to make it to the next phase up if and only if it has been displaced from its internal merge position and carried over to the edge of the phase. Within this simplified one-cycle model, the locus of binding relations can be either the computational system (henceforth C_{HL}) itself or the C-I interface. In what follows I will explore these two possibilities to decide whether this research question gets an “either ... or” kind of answer or whether binding relations are encoded both in the CHL and at the interface with the conceptual – intensional system.

2.3. Where does binding apply?

2.3.1. Binding holds at the C-I interface

Chomsky’s 1995 answer to the research question I have formulated at the end of the previous section is that binding applies at the C-I interface. Note that, if this is indeed the case, binding becomes a semantic notion (for a kin view see Reinhart) and nothing pertaining to the working of the C_{HL} has any say in how exactly binding relations are computed. Reuland 2001, 2005a, b opts for a more fine-grained answer and I will devote this section to spelling out the reasons that have led him to make this choice.

98 *Non-local binding and the Blocking Effect*

It is standardly acknowledged that semantic operations do not function according to locality constraints, i.e. they are not timed to strictly apply within phase-based domains. On the other hand, the received view concerning syntactic operations is that their application targets domains that are defined in terms of phases, because syntactic generation proceeds on a phase based level (Chomsky 2000, 2001, 2004, 2005). From this perspective, the observance (or disregard) of locality constraints provides the testing ground to decide whether a certain phenomenon applies within the C_{HL} or at the semantics interface. To bring the matter closer to home, deciding whether binding should be understood as a purely semantic notion rests ultimately on proving that it does not care in the least about locality constraints. Alternatively, such a black and white picture, i.e. “binding is semantic” or “binding is syntactic” might turn out not to be able to capture matters accurately. More precisely, it might be quite conceivable that some aspects of binding are handled at the C – I interface, while others still fall within the workings of the C_{HL} . This more fine-grained kind of answer does not come as a surprise at all because, as I have shown in Chapter 1, the pronominal elements that could undergo binding fall in different classes, defined in terms of different intrinsic properties. This basically means that pronouns will have different binding properties from bare reflexives or reflexive pronouns (the source of difference lies in the morpho-syntactic make-up of pronominal elements, i.e. in the features they bear when they enter the derivation). In a nutshell, this provides the foundation for the fine-grained answer that Reuland has chosen. He shows that collapsing pronoun binding with reflexive anaphor binding means that neither of them is anymore constrained by locality requirements. This prediction is most certainly borne out with respect to pronoun binding, as can be gleaned from the following example (and numerous others in the same vein):

23. *Every linguist* should resist when faceless forces threaten *his* field.
Every linguist (λx (x should resist when faceless forces threaten x 's field))

Note that the pronominal bound variable *his* is embedded in a syntactic island, an adjunct island. Quite obviously, semantic binding by the λ operator does not stumble upon syntactic islands. In fact, binding at the C-I interface does not care

about locality because it is variable binding by the sister of a λ operator³⁷. The only restriction on variable binding is c-command (Reinhart). Pronouns get converted into variables at the semantics interface. If binding applies, pronominal variables will be bound; if it does not, they will remain free. For instance, the pronoun *his* in (22) will turn into a variable that will be bound by the quantified subject, in accordance with the definition in footnote 28. This is so because the pronoun has a quantified, i.e. non-referential antecedent. If the antecedent had not been a quantifier, but a referential phrase, the pronoun could have co-referred with it or it could have stayed a free variable. The readings pronouns get in VP-ellipsis contexts, i.e. the sloppy and the strict readings, associate with the bound variable interpretation and the co-referent or free interpretation I have just alluded to.

What about bare reflexives and complex reflexives? Both of them get translated as variables at the C-I interface, just as is the case with pronouns having a quantified DP as an antecedent. The questions that need answering are the following: (i) do they also allow for all possibilities: the bound, coreferent and free variable readings and (ii) are they also correctly bound by the sister of a λ operator, i.e. is their binding free of locality constraints? If these two questions get positive answers, then there is no problem with seeing binding as a C-I interface phenomenon. If they do not, then Chomsky's 1995 proposal needs revisiting. Let me start with question (i) and resort to a Dutch example to make my point.

Compare English (23) to Dutch (24). The overall picture remains the same as in (23) in the sense that there is an available quantified antecedent, *iedere professional*, and a pronominal element (a bare reflexive in this case), *zich*, that gets translated as a variable at the C-I interface. The quantifier *iedere professional* binds the variable instantiated by *zich* (Reuland 2005 a).

24. Iedere professional voelde zich aan de kant geschoven.
 Each professional felt self to the side pushed
 "Each professional felt himself pushed aside".

³⁷ Reinhart 2000 gives the following definition of binding at the interface: " α A-binds β iff α is the sister of a λ predicate whose operator binds β ".

100 *Non-local binding and the Blocking Effect*

Dutch *zich* can only be a bound variable at the C-I interface (bound locally or non-locally), but not a free one, nor can it (co)refer. This is illustrated by its behaviour under VP-ellipsis, since only the sloppy reading is available.

25. Jan voelde zich aan de kant geschoven, en Marie ook.
Jan felt self to the side pushed, en Marie also
“Jan felt himself pushed aside, and so did Marie”.
= Marie felt Marie pushed to the side
≠ Marie felt Jan pushed to the side

This answers question (i). Let us now consider question (ii) by looking at the following English examples.

26. a. [Every man]_i will recoil when a lion attacks him.
b. *[Every man]_i will recoil when a lion attacks himself.
c. Every man (λx (x will when a lion attacks x))

Both the pronoun *him* and the reflexive anaphor *himself* convert into variables at the C – I interface. The pronoun is bound by the sister of the λ operator, that is, the quantified antecedent *every man* (cf. 26 c). Moreover, it does not matter at all that the pronoun has been embedded in the adjunct island. The reflexive, on the other hand, does not show the same kind of freedom. Sentence (26 b) is ill-formed because the reflexive should have related to an antecedent locally. The interface representation (26 c) does not have anything to say about this difference. It just shows that both the pronoun and the reflexive have turned into variables and it predicts that both should behave similarly with respect to being bound by the sister of a λ operator. Thus, question (ii) gets a negative answer as well.

Reuland notes that there is one more downside to viewing binding as an exclusively semantic notion. Keeping in mind the fact that pronouns get translated as variables at the interface, it is not at all clear why *him* in (27) cannot get the meaning *Everyone hated himself*, under its bound variable interpretation

(remember that pronouns with quantified antecedents are bound variables and get the sloppy reading under VP ellipsis)³⁸.

27. Everyone hated him.

These differences between pronouns and other categories of anaphoric elements such as bare reflexives call for an explanation. To anticipate the discussion a little, I want to point that Reuland proposes that *zich* in configurations such as (25) links up to its antecedent as a result of feature agreement checking mechanism that functions within the C_{HL}. The bound variable interpretation that it gets at the interface is the reflex of this already existing syntactic – encoded dependency. This significant detail casts doubt on the view that binding is completely handled at the C-I interface.

To conclude so far, I have shown that there are enough compelling reasons to unequivocally dismiss the idea that binding conditions should be understood in exclusively semantic terms.

I would like to end this section by summarizing the properties that characterize binding relations at the C-I interface. The following schematic recapitulation sums up the properties of binding at the interface (i.e. pronoun binding).

28. *Properties of pronoun binding (at the C – I interface)*

Sensitivity to locality	No
Bound variable, coreferent and free variable readings possible	Yes

29. *Properties of bare reflexive binding*

Sensitivity to locality	Yes
Bound variable, coreferent and free variable readings possible	No

³⁸ Reuland 2001 notes that the Dutch translation of the English sentence (27), i.e. **Iedereen haat zich*, is ungrammatical. In the grammatical variant *zich* has to be replaced by *zichzelf*, i.e. *Iedereen haat zichzelf*. Since both *zich* and *zichzelf* will get translated as variables at the interface, it is not at all obvious why this distinction should hold.

102 *Non-local binding and the Blocking Effect*

The conclusion to draw after contrasting these binding properties is that the restrictions on bare reflexive binding do not fit with the concept of semantic binding.

2.3.2. Binding has a syntactic residue

The previous section was meant to show that reducing binding to a semantic operation that takes place at the C-I interface leaves unresolved some important issues. That is, why is it the case that some pronominal elements, such as bare reflexives, get translated only as bound variables at the interface, while others could be either bound or free variables? And why is it that some cases of purportedly semantic binding involve sensitivity to locality (which includes sensitivity to island effects)? Moreover, binding as a pure interface phenomenon has no explanation for why it is that a pronoun that is transformed into a bound variable cannot yield a reflexive interpretation (cf. 27).

Reuland 2001 has explored the option that binding is not totally handled at the C-I interface. To put it differently, binding does have a “*syntactic residue*”. This will immediately entail that the part of binding that is handled in syntax obeys the locality (phase-sensitive dependencies) and economy requirements that apply to derivations in syntax (Chomsky 2000, 2001 a.o). Let me stop for a moment and consider what it actually means to say that binding has a syntactic residue.

I have mentioned in section 2.2. of the present chapter that an efficient model of computation involves a single cycle derivation in which only two operations apply, Merge (external and internal) and Agree. If a syntactic residue of binding exists, it immediately follows that all those cases that are relegated to the C_{HL} will contribute to redefining binding as emerging only as the result of the operations that legitimately apply in the C_{HL} , i.e. Agree and Merge. From this perspective, a Probe and a Goal relation underlies the binding process. Anaphors are easily conceptualized as Goals. On the assumption that it is the presence of unvalued features on Goals that make them eligible to enter syntactic computation (Chomsky 2001, a.o), it is reasonable to believe that anaphors come from the Lexicon into the derivation with a ϕ feature set that necessarily contains one or more unvalued features.

One of the most likely candidates to go in the derivation without value is the number feature. Number, an interpretable feature on nominals, is

expressed in the opposition singular – plural (I leave aside more complex cases that involve dual), which is formally marked by specialized morphemes. I take a nominal to be specified for number if its morphology shows the singular – plural distinction. If the morphologically marked distinction between singular and plural is missing because the plural form is the same as the singular one or if the plural is non-existent, then the number specification on the respective nominal is impoverished (see Reuland 2005 b for a discussion on the meaning and implications of ϕ feature *underspecification*). Number specification has consequences on interpretation because it is important to determine whether a nominal gets interpreted as an entity or a group or plurality of entities. Note that number is a feature that does not come with a fixed value either, in the case of reflexives (in Dutch / Romanian). This entails that unvalued number on the reflexive will turn the reflexive into an active Goal.

Apart from number, there is also the case feature that goes unvalued in the derivation. Case is standardly understood as an uninterpretable³⁹ feature that a nominal bears. It needs checking against a functional category that has a case checking feature (checking might require movement (or second merge) of the nominal or simply an Agree relation between the nominal and the functional category). Case marks the nominal as an eligible Goal to be attracted by the Probe located on the functional category, with both Probe and Goal seeking to check their features as soon as possible.

Summing up, underspecification for ϕ features and the need of nominals to have their case feature checked are the factors that trigger the formation of dependencies in syntax. Moreover, it is standardly acknowledged that syntactic dependencies hold within precisely defined local domains. The Goal anaphor must be in the complement domain of a Probe, which has, in its turn, a set of unvalued features that it seeks to value. If a Probe – Goal relation goes through between a Goal anaphor and its Probe antecedent, binding arises as a by-product of this relation. This updated version of binding falls in line with Chomsky's 2006 remark that uninterpretable features make binding possible⁴⁰ (here I take *uninterpretable* and *unvalued* to refer to the same kind of

³⁹ *Uninterpretable* in the sense that it does not make any contribution to the interpretation of a nominal the way ϕ features (person gender and number) do.

⁴⁰ Note that the LGB binding principles, such as Principle A, have no theoretical import in the model of efficient computation put forth by the minimalist program. They are

104 *Non-local binding and the Blocking Effect*

feature, i.e. one that allows the lexical item that bears it to participate in syntactic operations). The way to understand this remark is to think that uninterpretable features on both Probes and Goals push them to seek to value those features within phase-based domains.

The next section will lay down the basic details about the levels of representation at which interpretive antecedent – anaphor dependencies can be encoded.

3. Brief survey of an economic theory on the encoding of anaphoric dependencies

Reuland 2001, 2005 a, b has formulated an economy-based theory on the possible ways of encoding the dependency between an anaphoric form and its antecedent. In what follows I will make a concise survey of this theory, which I will adopt as the framework of my analysis of non-local binding. In the course of the exposition, I will draw on the theoretical notions I have introduced in section 2.

3.1. Syntactically encoded anaphoric dependencies

The cheapest, simplest way to establish an antecedent – anaphor dependency takes place in syntax. Binding in syntax comes as a result of covert movement or as a consequence of an Agree relation having been established between a Probe and a Goal (the choice between either of these two options depends on the version of the minimalist program that is adopted as theoretical background). Semantics solves the antecedent – anaphor dependencies that are not locally construed, but are sensitive to c-command and get only the bound variable interpretation. The rest, such as saliency of antecedents and perspective issues, is up to discourse.

reduced to a set of constraints that do not straightforwardly follow from the operations that take place in the CHL . In other words, the binding principles we have all known do not go beyond the status of simple stipulations that need to be derivable from the basic properties that underlie the functioning of the CHL and come at no theoretical cost whatsoever (see Reuland 2001).

Reuland 2005 uses data from Dutch to explore and support the possibility that binding arises as the result of Agree established between a Probe and a Goal. The evidence he brings to support the existence of a syntactic residue of binding has to do with the cases in which a bare reflexive anaphor, *zich*, functions as subject in ECM constructions (the classic subject to object raising configuration).

30. *Oscar* voelde *zich* wegglijden.
 Oscar felt self away slide
 “Oscar felt himself slide away”.

Zich in (30) shows the behavior of a pronominal element that can be semantically bound by the sister of a λ operator, i.e. it can only be interpreted as a bound variable that gets the sloppy reading under VP ellipsis. However, there is also a locality consideration at play because replacing *zich* by the pronoun *hem* leads to ungrammaticality:

31. **Oscar* voelde *hem* wegglijden.
 Oscar felt self away slide
 “Oscar felt himself slide away”.

This suggests that whatever dependency exists between *zich* and *Oscar* cannot be satisfactorily accounted for only in semantic terms because locality considerations are also at play here. The remaining option to explain this dependency is binding in C_{HL} , along the Probe - Goal line I have sketched above. Reuland shows that the syntactically encoded binding dependency between *zich* and *Oscar* in (30) results from two facts. First, the fact that smaller sub-dependencies link the matrix subject to the ECM subject: matrix subject – matrix T, matrix T – matrix V, matrix V – ECM subject) The matrix subject enters a dependency with the matrix T for case to be valued on the subject and the ϕ feature set on T to be valued as well. The matrix T and the matrix V are related by V to T raising. Finally, case valuation on the ECM subject motivates the last dependency in the sequence. Second, the fact that an Agree relation⁴¹ holds

⁴¹ I understand the Agree relation in terms of Agree links / feature sharing, in the spirit of Pesetsky & Torrego 2004.

between the two subjects (for precise details on how the derivation proceeds, see Reuland 2005 a) indicates that ECM configurations such as (30) involve a dependency between argument positions, i.e. the matrix subject and the ECM subject in an ECM configuration.

3.1. Binding at the C - I interface

I have already mentioned in section 2.3.1. that binding at the C – I interface cannot be captured in terms of a Probe - Goal relation, because it does not operate on the basis of locality constraints. This particular fact makes it a costlier option than the syntactic one. Binding at the interface requires that an operator – bound variable configuration be set up.

3.2. Covaluation in discourse

If an anaphoric form does not relate to its antecedent in syntax, under restrictions on locality for ϕ feature and case checking, and if it does not relate to the antecedent in semantics either, in an operator – bound variable configuration, then the respective anaphoric form is freed up and relates to whatever antecedent at the level of discourse. To put it differently, it is covalued with an antecedent. The logophoric usage of English *himself* represents a case of pronoun resolution at the discourse level.

32. a. The fact that there is a picture of himself_i hanging in the post office is believed (by Mary) to be disturbing Tom_i.
(Pollard and Sag 1992)
- b. Mary_i was extremely upset. That picture of herself_i on the front page of the Times would circulate all over the world.
(Pollard and Sag 1992)
- c. Rupert_i was not unduly worried about Peter's opinion of himself_i, nor was Fred_j. (A. Zribi-Hertz 1989)

In (32 a) *himself* does not stand in a c-command relation to its antecedent, *Tom*. The antecedent of *herself* in (32 b), *Mary*, is extrasentential. Even if *himself* is c-commanded by *Rupert* in (32 c), which would rule in the bound variable reading if a quantified antecedent had replaced *Rupert*, the fact remains that *himself* can get not only the bound variable interpretation, but also the strict one (see Zribi – Hertz and also section 4.3). Covaluation relations are encoded in discourse and are the costliest, because the anaphoric forms “leave” both syntax and semantics as separate trivial chains.

3.3. Interim conclusions (ii)

I have attempted to show in the previous discussion that, depending on (i) the intrinsic properties anaphoric forms have, such as the set of ϕ features they have (and need to check), their specification for the [\pm referential marker] feature and the [\pm R] feature as well as on (ii) their case checking requirements, anaphors will enter dependencies with their antecedents at the syntactic, semantic and discourse level. The dependency that involves the least effort will be formed in syntax, as a result of feature and case checking. The next option on the scale of costliness are the dependencies formed in semantics, which require that anaphors be c-commanded by their antecedents and be interpreted as bound variables. The most costly type of dependency will hold at the level of discourse.

After this terminological and theoretical excursus on dependency encoding strategies, I will concentrate entirely on NLAs. First, I will support with empirical evidence the defining properties of NLAs, i.e. subject orientation, c-command, and, in addition, the bound variable reading they get in VP-ellipsis contexts. In doing so, I will lay particular focus on Romanian NLAs. On the basis of the empirical evidence presented, I will conclude that Romanian NLAs are licensed in a structural binding configuration. Second, I will go over the empirical evidence that supports this point. I will end this chapter by suggesting that Romanian NLAs enter an A'-dependency.

4. *Cross linguistic core properties of NLAs*

4.1. **Subject orientation**

Non-local anaphors have been argued to always be subject-oriented⁴², as (33) illustrates for Danish (Vikner 1985):

33. *Peter lovede Anne; at vaske sig.
Peter promised Anne to wash him

Subject orientation has been turned into a generalization that holds consistently with long distance dependencies that involve NLAs. It has prompted researchers to argue that non-local anaphors must enter a structural binding configuration (Huang & Tang 1991, Cole & Sung 1990, 1994). Syntactically, subject-orientation has been argued to be the result of (possibly covert) movement that brings the NLA in the inflectional domain where the subject is located. Once this step taken, feature checking between the NLA and the subject follows and an interpretive dependency will arise. In other words, the syntactic view chooses to conceive of non-local binding as a result of (covert LF) movement. As for the details on how movement proceeds, both the head to head movement and the phrasal A'-movement possibilities have been advocated for. In the first case, the NLA moves as if it were a sort of clitic (some approaches have taken it to be an LF clitic. See Pica 1991). In the latter case, it has been suggested that NLAs move as phrases (See Huang & Tang 1991). According to the head to head movement hypothesis, NLAs adjoin successive-cyclically to all the available T nodes, as in I have schematically shown in (34). Consequently, the NLA will always end up in a position that is c-commanded

⁴² Subject orientation for *sine* applies only to the cases of long distance binding. Locally, it is possible for *sine* to have an (in)direct object antecedent as well:

- (1) a. L-au interogat pe suspect despre sine.
Him_{CL.ACC} have interrogated on suspect about self
"They interrogated the suspect about himself".
- b. I-a vorbit Mariei despre sine.
To her_{CL.DAT} has talked Maria_{DAT} about self
"He/she talked to Mary about herself".

by the subject, the specifier of T. The preference NLAs have for subject antecedents as well as their subject orientation straightforwardly derive from this type of configuration.

34.

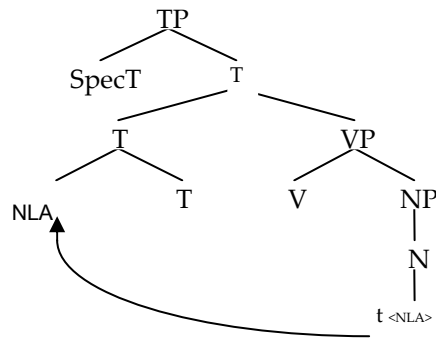

The phrasal movement hypothesis involves movement by substitution first of all to the Spec, CP of the embedded clause and then further on. In this case, subject orientation results from the long distance reflexive having passed through Spec, TP on its way up to Spec, C, as shown in (35).

35.

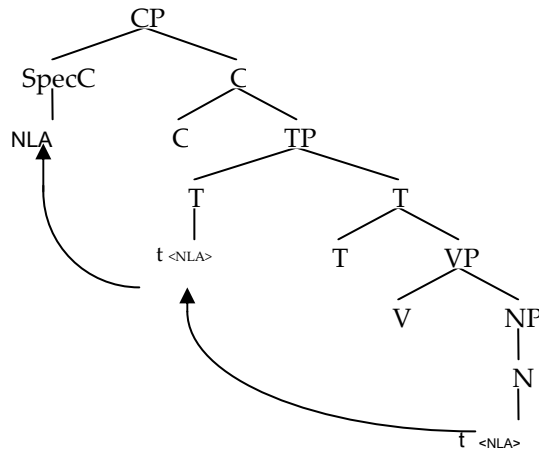

As already discussed in chapter 1, section 2.2, Romanian has non local anaphors, as I exemplify below in (36) – (41).⁴³

⁴³ There are two additional arguments against analyzing non-local *sine* as a logophor. The first argument involves anaphors in a non-argument position such as reflexives embedded in picture NPs. Reinhart & Reuland (1993) argue that anaphors in picture NPs could function as logophors. This is so because these anaphors are not arguments of reflexive predicates. I have already mentioned at the beginning of this chapter that English *himself* may take on the logophor usage. Here is an example.

- (1) The picture of herself_i on the front page of the Times confirmed the allegations Mary_i had been making over the years.

Note Romanian *sine* is not at all felicitous in picture NPs.

- (2) *Pozele cu sine fusesera publicate in toate ziarele de scandal.
 *Pictures.the with self had.been published in all newspapers.the of scandal
 Primul ministru era disperat.
 Prim.the minister was desperate.
 “*The pictures of himself had been published in all tabloids. The prime minister was desperate”

Again, if *sine* could be used as a logophor, like *herself* in (1), the ungrammaticality of (2) would not have been expected.

36. Adrian_i spera ca preşedintele partidului_j să
 Adrian hopes that_{SUBJ COMP} president.the of party.the să_{SUBJ}
 conteze mai mult pe sine_{i, j}.
 count much more on self
 “Adrian hopes that the president of the party should count more on
 Adrian/the president of the party”.
37. Adrian_i a cerut ca judecătorul_j să aibă
 Adrian has asked that_{SUBJ COMP} judge.the să_{SUBJ} have
 încredere în sine_{i, j}.
 trust in self
 “Adrian asked that the judge have trust in the judge/Adrian”.
38. Politicianul_i a ordonat ca şantajistul_j
 Politician.the has ordered that_{SUBJ COMP} blackmailer.the
 să nu dezvăluie nimic despre sine_{i, j}.
 să_{SUBJ} not reveal anything about self
 “The politician ordered that the blackmailer should not reveal
 anything about the blackmailer/the politician” .
39. Adrian_i crede că preşedintele partidului_j vede
 Adrian believes that_{IND} president.the party.the sees in self future.the
 în sine_{i, j} viitorul ţării.
 in self future.the of country.the
 “Adrian believes that the president of the party sees in the
 president/Adrian the future of the country”.

The second argument comes from island effects. The literature on non-local binding has stressed that, generally speaking, non-local binding freely violates islands (see Cole et al (2001) for Chinese, Chierchia 1989 for Italian, for instance). Given this background, it is not very clear why Romanian non-local binding dependencies cannot entirely circumvent island effects. I will return to this issue below.

112 *Non-local binding and the Blocking Effect*

40. Adrian_i știe ca judecătorul_j va avea încredere în sine_{i,j}.
 Adrian knows that_{IND} judge.the will have trust in self
 “Adrian knows that the judge will trust the judge/Adrian”.
41. Politicianul_i se teme că ziaristul_j îi
 Politician.the s_{REFL}.CL fears that_{IND} journalist.the them_{CL}.ACC
 va compara pe corupți cu sine_{i,j}.
 will compare on corrupt.the_{ACC} to self
 “The politician fears that the journalist will compare the corrupt to
 the journalist/the politician”.

Romanian non-local anaphors have a strong preference for subject antecedents. Indirect objects in the matrix clause do not make eligible non-local antecedents. Example (42) shows that the dative indirect object, *Maria*, selected by the matrix predicate cannot antecede the NLA. More examples with infelicitous indirect object antecedents are given in (43)⁴⁴.

42. Mariei_i i s-a raportat [_{CP} ca [Alex_j râde de sine_{i,j}]].
 To.Maria_{DAT} to her_{CL}._{DAT} s_{REFL}.CL has.been reported that A laughs at self
 “It was reported to Maria that Alex laughs at Maria/Alex”.
43. a. Alex_i i -a dezvaluit Mariei_j [_{CP} că [clovnul_k râde
 Alex to her_{CL}._{DAT} has revealed to.Maria_{DAT} that clown.the laughs
 pe ascuns de sine_{i,*j,k}]].
 secretly at self
 “Alex revealed to Maria that the clown laughs secretly at
 Alex/Maria/the clown”.

⁴⁴ Note that the experiencer objects of some psych verbs can antecede *sine*. Compare the following example to (43 b).

- (1) Lui Alex_i îi place să muncească soția lui_j pentru sine_{i,j}.
 To Alex_{DAT} to.him_{CL}._{DAT} pleases s_{SUBJ} work wife.the his for self
 “It pleases Alex for his wife to work for his wife / Alex”.

- b. Alex_i i s-a plîns Mariei_j [CP că
 Alex to her_{CL.DAT} serefl_{CL} has complained to.Maria_{DAT} that
 [soția lui_k contează prea mult de sine_{e_i,*_j,k}]].
 wife.the his relies too much on self
 “Alex complained to Maria that his wife relies too much on
 Alex/Maria/herself”.

The same observation holds for direct object antecedents, as illustrated by (44).

44. George_i l-informat pe Alex_j
 George him_{CL,ACC} has informed on Alex
 [că soția lui a vorbit frumos despre sine_{e_i,*_j,k} la petrecerea de aseară]
 that wife.the his has spoken nicely about self
 “George informed Alex that his wife spoke nicely about
 herself/Alex/?George at the party last night”.

I will take subject-orientation to be a property of those non-local anaphors whose distribution can be captured by a Probe – Goal relation.

4.2. C-command

Analyses of non-local anaphors that show subject orientation also predict c-command to hold between the subject antecedents and the respective anaphors. Consider the following example from Icelandic⁴⁵. The bare reflexive in the infinitive complement, *sér*, cannot relate to the non c-commanding antecedent, *Jóns*.

45. [Àlit Jónsi]j er sagt [tj hæfa sér vel].
 Belief John’s is said suit self well.
 “John’s belief is said to suit him well”.

C-command holds for Romanian non-local binding dependencies:

⁴⁵ Reuland and Sigurjonsdottir 1997 have argued that *sig* embedded in infinitive clauses is an NLA.

114 *Non-local binding and the Blocking Effect*

46. [Părererea lui Harry]_i_k e că Ron_j contează pe sine^{*_{i, j}} mereu.
Opinion.the of Harry_{GEN} is that Ron counts on self always
“Harry’s opinion is that Ron always counts on Ron/Harry”.

The example above shows that a non-local non-commanding antecedent, *Harry* in this particular case, cannot be construed with the non-local anaphor. Only the local interpretation obtains, with *Ron* as antecedent, holds for (46).

Just as the subject orientation generalization, c-command between an antecedent and a non-local anaphor will be taken as indicative that a structural binding configuration exists between the two.

4.3. Sloppy and strict readings under VP-ellipsis

In Dutch, reflexive anaphors in VP-ellipsis contexts will always get the sloppy reading, not the strict one. For instance, a sentence like *Jan haat zichzelf en Piet ook* can only mean “John hates himself and Peter hates himself”, but not “*John hates himself and Peter hates him (= John)”. In English, the sloppy reading is clearly the most prominent one, although speakers occasionally also get the strict reading. This contrast between Dutch and English is presumably due to the fact that Dutch *zichzelf*, due to its feature make-up, never allows a free ‘logophoric’ reading, whereas English *himself*, under the conditions discussed in R&R 1993 does.

47. a. Jan haat zichzelf en Piet ook.
b. John hates himself and so does Peter.

In contrast with reflexive anaphors, pronouns in VP-ellipsis contexts are open to both the sloppy and the strict reading, which means, in semantic terms, that pronouns could be either bound or free variables.

It has been shown that the behavior of logophors in VP-ellipsis contexts patterns with that of pronouns, as shown in (48).

48. Rupert_i was not unduly worried about Peter’s opinion of himself_i, nor was Fred_j.

The sentence in (48) has either the meaning (i) *Fred was not worried about Peter's opinion of Rupert* or (ii) *Fred was not worried about Peter's opinion of Fred* (strict versus sloppy).

Icelandic logophoric *sig* shows similar behaviour to logophoric *himself*, except from one differentiating detail. Whenever *sig* is not c-commanded by its antecedent, it supports only the strict reading under VP-ellipsis, i.e. the sloppy one does not obtain (Thráinsson 1991).

49. Skoðun Jons_i er [að sig_i vanti hæfileika] og það er skoðun Peturs_j líka.
Opinion John's is that sig lack_{SUBJ} talents and that is opinion Peter's too
"John's opinion is that sig lacks talents and that is Peter's opinion too".
≠ Peter's opinion is that Peter lacks talents (sloppy)
= Peter's opinion is that John lacks talents (strict)

What about the behaviour of bare reflexive NLAs under VP-ellipsis? Let us first investigate what happens to them locally. As expected, the VP-ellipsis test indicates that local *sine* supports the sloppy reading, but not the strict one. In this respect *sine* patterns with local *himself*:

50. George contează pe sine și Alex la fel.
George counts on self and Alex the same.
"George counts on himself and Alex does too".
≠ Alex counts on George (strict)
= Alex counts on Alex (sloppy)

Contrast (50) with (51) where *sine* has been replaced by the pronoun *el* and a strict reading becomes an option:

51. Bill contează pe el și John la fel.
"Bill counts on him and John does too".
= Bill counts on Bill and John counts on Bill (strict)
= Bill counts on Bill and John counts on John (sloppy)

Non-local *sine* behaves as a bound variable and gets the sloppy reading. Consider (52).

116 *Non-local binding and the Blocking Effect*

52. Adrian știe că judecătorul va avea încredere în sine și Alex la fel.
Adrian knows that_{IND} judge.the will have trust in self and Alex the same
“Adrian knows that the judge will trust Adrian and Alex knows that the judge will trust Alex”.
= Alex knows that the judge will trust Alex
≠ Alex knows that the judge will trust Adrian

4.1. The Blocking Effect

The Blocking Effect represents an intervention phenomenon that characterizes non-local anaphors involved in non-local dependencies. The Blocking Effect (henceforth the BE) shows up when a potential non-local antecedent of an NLA c-commands another potential antecedent (that occupies a lower position in the configuration) that does not agree in ϕ features with the NLA. Let me use Chinese to show how blocking works (for the time being, I will keep things simple and discuss blocking on subject antecedents, but direct and indirect objects could also induce blocking (at least in Chinese, see Cole et al 2001, a.o)).

53. a. Zhangsan_i renwei Lisi_j zhidao Wangwu_k xihuan ziji_{i,j,k}.
Zhangsan thinks Lisi knows Wangwu likes self
“Zhangsan thinks Lisi knows Wangwu likes self”.
- b. Zhangsan_i renwei wo_j zhidao Wangwu_k xihuan ziji_{i,*j,k}.
Zhangsan thinks I know Wangwu likes self
“Zhangsan thinks I know Wangwu likes self”.

The first person intervening subject *wo* blocks coreference between *ziji* and the superordinate subject *Zhangsan* and confines *ziji* to bind locally to *Wangwu*. If the first person had not been there, all three interpretations would have been ruled in: *ziji* would have taken all the (third person) subjects as antecedents, (cf 53 a).

The BE is relevant to the discussion in this chapter because it arises with non-local anaphoric dependencies. I will give an overview presentation of it. I will postpone a discussion of the specifics of the Blocking Effect in Romanian

until Chapter 4. In what follows, I will limit myself to setting up the background information on the BE.

The BE is a complex phenomenon that lends itself to explanations in terms of syntax, semantics and discourse/functional (at least the BE as has been investigated in relation to East Asian languages). Let us concentrate on the examples in (53) and see, in turns, what a syntactic, semantic and discourse perspective has to say about it. A quick glance at all the possible antecedents in (53) will reveal that all of them are subjects that c-command *ziji*. In a series of studies that have spanned more than ten years, Cole & Sung (1990, 1994), Cole, Hermon and Lee (2001) propose that the BE results from the fact that *ziji* undergoes successive-cyclic movement that adjoins it in the T field of each clause in which it finds an antecedent. The phrase marker in (54) schematizes the case in which no BE is expected to arise because the features on the subject, T and the non-local anaphor are non-distinct.

54.

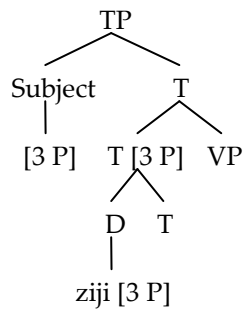

Once in the T adjoined position, *ziji* will be c-commanded by the subject in Spec, T. This also implies that *ziji* will be in a specifier – head agreement configuration that will allow it to check features with those of the subject antecedent. The feature make-up of T counts as well. Crucially, Cole & Sung assume that the T head in languages like Chinese, which do not mark subject – predicate agreement overtly, has a deficient agreement feature set (deficient in the sense that it is not specified at all). They also assume that, after a non-local anaphor has adjoined to T, the former can percolate its feature set to T. This is shown in (54), where the same agreement features are present on T and the anaphor. If the

118 *Non-local binding and the Blocking Effect*

subject happens to have matching features, i.e. non-distinct from those on *ziji* and T, then the BE is circumvented. If the subject has distinct features (cf 53 b), the BE will arise, as shown below.

55. *

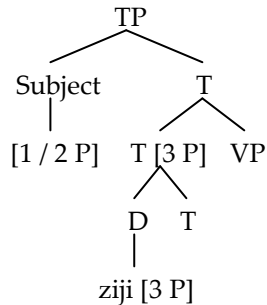

Cole & Sung’s analysis makes a strong typological prediction with regard to the BE. Languages that do not mark subject – verb agreement overtly, such as Chinese and Japanese, will display the BE. Languages that do mark overtly subject – predicate agreement, such as Hindi-Urdu, Kannada, Icelandic, Norwegian, Italian, do not show the BE. This is so because the T head in this second group of languages has its own agreement feature set; it does not need to borrow the feature set of the long distance anaphor.

The starred phrase marker in (55) shows that the BE should arise because of the feature mismatch between the subject, on the one hand, and T and the non-local anaphor, on the other. Cole & Sung’s proposal shows that syntax has a say in triggering the BE. For their analysis to work, c-commanding subject antecedents should be the only type of antecedents that cause the BE.

The Chinese data runs counter to this result. Both antecedents that are more deeply embedded in a phrase, i.e. non c-commanding subjects (cf. 56), and first and second person indirect objects trigger blocking (Xue, Pollard and Sag 1994, Pan 2001).

56. [Zhangsan_i de jiaobao] hai-le ziji.
 Zhangsan de arrogance harm_{PERF} self
 “Zhangsan’s arrogance harmed him”.

57. Zhangsan_i renwei Lisi_j cong wo_k nar tingshuo-le ziji_{*i,j,*k}.
 Zhangsan think Lisi from I there hear-say_{PERF} self de fenshu
 “Zhangsan thinks Lisi heard from me his / my score”.

The general pattern seems to be that first and second person, irrespective of the grammatical function, trigger the BE (Pan 2001 and other references). This descriptive observation is the starting point for the discourse explanation of the BE, to which I have already alluded in section 1.2.1. Since first and second person lexical items refer to the most salient participants in the speech act, i.e. the speaker and the addressee, the BE arises exactly in those cases when a first or second person intervenes between a remote and a local third person antecedent. This in itself seems to be quite a reasonable take on the matter. However, note that it is not only person mismatches that result in the BE. Number mismatches could have the same effect.

58. Tamen_j zhidao Lisi_i piping ziji_{i,*j}.
 They know Lisi often criticizes self
 “They know that Lisi often criticizes himself/them”.

First and second person c-commanding or non c-commanding antecedents may introduce saliently prominent entities in discourse, but the number feature does not have anything to do with saliency. The data about number seems to suggest yet again that the BE has something to do with the agreement feature checking.

This brief discussion of the BE had a twofold goal. The first has been to highlight the fact that the BE is a phenomenon that arises with non-local anaphoric dependencies. Cross-linguistically, it is a quite complex phenomenon, amenable to explanations into which both syntactic, and discourse functional factors may enter. However, given the existing cross-linguistic variation, as for instance between Chinese and Icelandic, discourse cannot be the sole factor. Secondly, this discussion, then, provides the motivation for me to go along with Cole & Sung and take it that, at least partially, the BE needs a syntactic explanation.

I will show in what follows that Romanian also displays a restricted version of the BE (restricted by comparison to what goes on in Chinese, where not only subjects give rise to blocking). Let us have a look at a couple of BE

120 *Non-local binding and the Blocking Effect*

examples. All the (a) examples in the sequence below illustrate the BE: (59 a) shows blocking by an intervening first person. (60 a) shows blocking by a second person. (61 a) suggests that third person plural intervening subjects trigger blocking. Finally, (62 a) and (63 a) show blocking by second person and first person plural.

59. a. Andrei_i e total convins că am crezut întotdeauna în sine^{*i}.
Andrei is totally convinced that have.I believed always in self
“Andrei is totally convinced that I always believe in himself”.
- b. Andrei_i e total convins că tatăl lui_j a crezut
Andrei is totally convinced that father.the his has believed
întotdeauna în sine_{i,j}.
always in self
“Andrei is totally convinced that his father always believed in his father/Andrei”.
60. a. [Președintele partidului]_i bănuiește că ai dezvăluit
President.the party.the_{GEN} suspects that have.you revealed
secrete compromițătoare despre sine^{*i}.
secrets compromising about self
“The president of the party suspects that you revealed compromising secrets about himself”.
- b. [Președintele partidului]_i îl bănuiește pe ziarist_j că
President.the party.the_{GEN} him suspects on journalist that
a dezvăluit secrete compromițătoare despre sine_{i,j} la un pahar
has revealed secrets compromising about self at a glass
de bere
of beer
“The president of the party suspects that the journalist revealed compromising secrets about the journalist/the president while drink a glass of beer”.

61. a. George_i a regretat că la întâlnirea de aseară prietenii
George has regretted that at meeting.the of last.night friends.the
lui au amintit istorii neplăcute despre sine_i.
his have reminisced stories unpleasant about self
“George regretted that at last night’s meeting his friends
reminisced unpleasant stories about himself”.
- b. George_i a regretat că la întâlnirea de aseară
George has regretted that at meeting.the of last.night
fratele lui_j a amintit istorii neplăcute despre sine_{i,j}.
brother.the his has reminisced stories unpleasant about self
“George regretted that at last night’s meeting his brother
reminisced unpleasant stories about his brother/George”.
62. a. George_i a fost surprins că ați vehiculat despre sine_i
George has been surprised that have.you_{PL} circulated about self
asemenea minciuni.
such lies
“George was surprised that you circulated such lies about
himself”.
- b. George_i a fost surprins că fratele lui_j a vehiculat
George has been surprised that brother.the his has circulated
despre sine_{i, j} asemenea minciuni.
about self such lies
“George was surprised that his brother circulated such lies
about his brother/George”.
63. a. George_i ne-a explicat că noi vedem în sine_i un monstru.
George to us has explained that we see in self a monster
“George explained to us that we see a monster in himself”.

122 *Non-local binding and the Blocking Effect*

- b. George_i ne-a explicat că nevasta lui_j vede în sine_{i, j}
George to us has explained that wife.the his sees in self
un monstru.
a monster
“George explained to us that his wife sees a monster in
herself/George”.

As already mentioned, I will put off until the next chapter the task of giving an explanation for the BE, as seen in (59) – (63). For now, I would like to conclude by saying that subject interveners with mismatching person and/or number features trigger the BE for the non-local dependencies in which *sine* enters. Intervening direct and indirect object with mismatching features do not trigger the BE. This may be so because neither kind of object meets the structural conditions for being visible – and a possible antecedent - for non-local *sine*, as discussed in section 4.1.

5. *Peculiarities of Romanian non-local anaphors*

This last section of the present chapter is organized as follows. I will start by introducing the peculiarities that characterize non-local anaphoric dependencies in Romanian. That is, non-local anaphoric dependencies are established out of finite clauses and are sensitive to relativized minimality effects. Starting from this particular type of intervention effects, I will suggest that non-local anaphoric dependencies in Romanian have the characteristics that follow from A'-dependencies. To test the A' status of the non-local relation, I will draw on arguments from: intervening effects induced by (non) D-linked *wh*-word antecedents, non D-linked quantified DP antecedents, bare quantifier antecedents and focus-sensitive adverbs such as *numai* (*only*). I will finish by summing up three descriptive generalizations regarding non-local anaphoric dependencies that I will account for at length in the next chapter.

5.1. **Type of inflection in the complement clause**

As outlined in Chapter 1, *sine* can be bound outside a tensed domain, whether indicative or subjunctive:

64. a. Primul ministru_i speră ca soția lui_j să
 Prime.the minister hopes that_{COMP} SUBJ wife.the his să_{SUBJ}
 vada un lider in sine_{i, j}.
 see a leader in self
 “The prime minister hopes that his wife will see a leader in herself/himself”.
- b. Primul ministru_i a refuzat să le vorbeasca soția lui_j
 Prime.the minister has refused sa_{SUBJ} to them_{CL.DAT} talk wife.the
 despre sine_{i, j} ziariștilor.
 about self to.newspapermen.the_{DAT}
 “The prime minister refused for his wife to talk to the newspapermen about herself / himself”.

From this, one might expect that *sine* would also be allowed to violate the SSC in a small clause construction. However, as the pair of examples of examples in (65) and (66) show, this is not the case:

65. a. George_i l-a auzit pe Alex_j rîzînd de sine^{*i, j}.
 George him_{CL.ACC} has heard on Alex laughing_{GER} at self
 “George heard Alex laughing at Alex/George”.
- b. George_i a auzit că Alex_j rîde de sine_{i, j}.
 George has heard that Alex laughs at self
 “George heard that Alex laughs at Alex/George”.
66. a. George_i îl consideră pe Alex_j încrezător în sine^{*i, j}.
 George him_{CL.ACC} considers on Alex trusting in self
 “George considers Alex self-trusting”.
- b. George_i e conștient că Maria_j crede în sine_{i, j}.
 George is aware that Maria trusts in self
 “George is aware that Maria trusts in herself/George”.

This is a very striking pattern in view of what is found cross-linguistically. Interestingly, an approach to binding domains such as Manzini and Wexler

124 *Non-local binding and the Blocking Effect*

(1987), based on the subset principle, would predict that such a pattern cannot obtain. In general what one sees is that accessibility of a hierarchically higher domain always entails accessibility of a lower domain (for instance in the hierarchy of binding domains in Germanic as discussed in Everaert 1986 and various contributions in Koster and Reuland 1991). Also, the fact that indicative clauses do not form opaque domains is remarkable. Clearly, this pattern is in need of an explanation. Providing such an explanation is the task to be carried out in Chapter 4.

5.2. **Relativized minimality effects**

The examples below show that the dependency relation between *sine* and its antecedent is subject to relativized minimality requirements (Rizzi 2002). Let me start the discussion by laying out a brief introduction on the notion of relativized minimality (Rizzi 1990, Rizzi 2002, Starke 2001, Grillo 2005). The notion has been devised to account for the fact that basic syntactic relations must be local despite the fact that nothing precludes a syntactic dependency from being unbounded (of course, the unboundedness of syntactic dependencies reduces to a sequence of local relations). To be more precise, consider the following configuration, where the letters represent syntactic objects.

67. ... X ... Z ... Y ...

Relativized minimality predicts that a relation between Y and X cannot be established if Z could have the relevant properties that X has and that enable X to entertain a syntactic relation with Y. The following definitions from Rizzi 2002 state in a precise manner the facts that I have just mentioned informally.

68. a. *Relativized minimality*
Y is in a Minimal Configuration (MC) with X iff there is no Z such that
(i) Z is of the same structural type as X, and
(ii) Z intervenes between X and Y
- b. *Structural type*
Same structural type = Spec licensed by features of same class

- c. *Classes of relevant features*
- (i) Argumental: person, number, gender, case
 - (ii) Quantificational: *Wh*, Neg, measure, focus...
 - (iii) Modifier: evaluative, epistemic, Neg, frequentative, celerative, measure, manner,....
 - (iv) Topic

Let us exemplify relativized minimality at work. Consider the following examples from Rizzi 2002.

69. a. How did you solve the problem *t*?
 b. * How do you wonder *who* could solve this problem *t*?

The *wh* element *how* in (69 a) needs to check its [+wh] feature against the closest C head and, for that reason, it moves to Spec, C. Checking of the [+wh] feature follows. The same relation between *how* and the relevant C head cannot hold anymore in (b) because there is the intervening *wh* element *who*, which bears the same [+wh] feature (see c (ii) above), is closer to C and can, therefore, enter a checking relation with this head.

In what follows, I will illustrate that constituents that have quantificational properties affect non-local binding. That is to say, (non) D-linked *wh*-words (70), non D-linked quantified DPs (71), bare quantifiers (72), affective operators: the focus-sensitive *only* (*numai*) will enforce only the local interpretation of the bare reflexive *sine*.

70. George_i știe [cine_j/care_j contează mereu pe sine<sup>?_{i, j}].
 George knows who/which counts always on self
 "George knows who/which (one) counts always on who/George".</sup>
71. George_i știe că [orice om_j contează mereu pe sine<sup>?_{i, j}].
 George knows [that any man counts always on self]
 "George knows that any man always counts on any man/*George".</sup>
72. George_i știe [că nimeni_j nu contează niciodată pe sine<sup>?_{i, j}].
 George knows that nobody not counts never on self
 "George knows that nobody ever counts on nobody/George".</sup>

73. George_i știe [că numai Alex_j contează pe sine_{i,j}]
 George knows that only Alex counts on self
 “George knows that Alex counts only on Alex/George”.

So far, the picture that emerges is the following: the non-local anaphor under scrutiny here is forced to enter a local dependency whenever (a) its local antecedent has quantificational properties, i.e. it is a (non) D-linked *wh*-word, a non D-linked quantified DP, a bare quantifier or a focus-sensitive adverb such as *numai* (only) or (b) an item with quantificational properties, such as negative quantifiers, occupies the left periphery. Note that, if a topicalized adverb occupies Spec-T, the long distance reading becomes possible again, but this is expected since topics do not act like blockers of A'-dependencies (Rizzi)⁴⁶.

74. George_i crede că [intotdeauna contează Alex_j pe sine_{i,j}].
 George believes that always counts Alex on self
 “George believes that Alex always counted on Alex/George”.

5.3. Non-local anaphors and island sensitivity

If *sine*'s non-local distance behaviour is the result of an A'-dependency, one might expect that it must behave similarly to *wh*-movement and show sensitivity to islands. However, at first sight the situation might not seem to be very clear-cut because non-local binding of *sine* out of adjunct islands and relative clauses proves to be ungrammatical, but binding out of complex DPs and *wh*-islands does not produce blatant ungrammaticality, as would be expected.

In what follows, I will contrast extraction of *wh*-phrases out of islands with non-local binding of *sine* out of islands to offer a detailed view of the facts. When possible, I will contrast extraction of *cine* (who) with extraction of *sine*.

⁴⁶ Also, *sine* moves as a head, but the adverb moves as a phrase. On this account, interference effects are not expected.

Complex DP (followed by a complement clause)⁴⁷

75. a. George a auzit zvonul că președintele a
George has heard rumor.the that president.the has
sărutat-o pe secretară.
kissed her_{CL.ACC} secretary_{ACC}
“George heard the rumor that the president kissed the
secretary”.
- b. *Pe cine a auzit George zvonul că a sărutat președintele?
On whom has heard G rumor.the that has kissed president.the?
“Who did George hear the rumor that the president kissed?”
76. George_i uraște faptul că Alex_j râde de sine_{i,j}.
George hates fact.the that Alex laughs at self
“George hates the fact that Alex laughs at Alex/George”.

Complex DP (followed by a relative clause)

77. a. Alex cunoaște un vecin care pariază milioane la curse.
Alex knows a neighbor which bets millions at races
“Alex knows a neighbor who bets millions at races”.
- b. *Ce cunoaște Alex un vecin care pariază la curse?
What knows Alex a neighbor which bets at races?

⁴⁷ For all it is worth, it seems that when *sine* is embedded in an adjunct PP, the acceptability of binding out of a complex NP decreases.

- (1) Cartman_i a răspindit zvonul că Stan_j a îndreptat pușca spre sine^{?i,j}.
Cartman has spread rumor.the that Stan has directed gun.the towards self
“Cartman spread the rumor that Stan directed the gun at himself”.
- (2) Cartman_i a confirmat zvonul că Stan_j a contat prea mult pe sine_{i,j}.
Cartman has confirmed rumor.the that Stan has counted too much on self
“Cartman confirmed the rumor that Stan counted too much on himself”.

128 *Non-local binding and the Blocking Effect*

78. Harry_i cunoaște un vrăjitor_j care experimentează pe sine noi vrăji?^{*i, j}
Harry knows a wizard which experiments on self new spells
“Harry knows a wizard which experiments new spells on the wizard/Harry”

Adjunct island

79. a. Alex a protestat când inspectorul i-a pus întrebări.
A has protested when inspector.the him_{CL.DAT} has put questions
“Alex protested when the inspector asked him questions”.
- b. *Cine a protestat Alex când i-a pus întrebări?
Who has protested Alex when him _{CL.DAT} has put questions
80. George_i protestează [când Alex_j râde de sine^{*i, j}].
George protests when Alex laughs at self
“George protests when Alex laughs at Alex/George”.

Wh-island

81. Cine te întrebi dacă trebuie să răspunda la întrebări?
Who _{TEREFL.CL} wonder whether must.pro să_{SUBJ} answer at questions?
“Who do you wonder whether (he) should answer the questions?”
82. George_i se întreabă dacă Alex_j contează mereu pe sine_{i, j}.
George _{SEREFL.CL} asks whether Alex countsalways on self
“George wonders whether Alex always counts on Alex/George”.

Let us see what the islands that do not preclude non-local binding have in common. I suggest they share the fact that they are not introduced by quantificational elements. The complementizer *că* (that) as well as the *wh*-complementizer *dacă* (if) do not have quantificational properties. The time adverbial adjuncts I have discussed, on the other hand, are introduced by a quantificational *wh*-phrase, i.e. *când* (when). Relative clauses, in their turn, are headed by nominals that are related to a quantificational *wh*-phrase. From this, it looks like it makes a whole world of difference whether there is or there is not a quantificational *wh*-phrase intervener in the non-local binding cases. This

conclusion also falls in line with example (70) in the section on relativized minimality, which shows a *wh*-island that is introduced by a quantificational *wh*-phrase and, consequently, limits the bare reflexive to a local relation. For the time being, I will retain the descriptive generalization that the grammaticality of non-local binding out of islands depends on the type of complementizer or intervening element. I will come back to this issue in Chapter 4 when I sketch an account of the island facts, based on this descriptive generalization.

6. Conclusions

I would like to conclude this chapter with presenting three descriptive generalizations about non local anaphoric dependencies in Romanian.

Descriptive generalization (1) *Romanian non-local anaphoric dependencies are sensitive to relativized minimality effects.*

Descriptive generalization (2) *Romanian non-local anaphoric dependencies only 'escape' FULL clauses; small clauses block these dependencies.*

Descriptive generalization (3) *Romanian non-local anaphoric dependencies are sensitive to the blocking effect, the BE. For Romanian, this means that intervening c-commanding first and second person antecedents as well as intervening c-commanding plural antecedents block the non-local anaphoric dependency of sine.*

CHAPTER 4

Analysis of the non local binding phenomenon

1. *Introduction*

I have concluded the previous chapter with three descriptive generalizations that characterize non-local binding in Romanian. The task of the present chapter will be derive these generalizations from basic facts that underlie binding and A'-dependencies within the computational system.

More precisely, the proposal that I want to make so as to incorporate these descriptive generalizations into a theoretical explanation will extend the search for the syntactic residue of binding. I will propose that the syntactic mechanism for encoding binding relations should be conceived of as Agree. With this in mind, the next question to ask is what types of features enter into the syntactic encoding of binding relations. Reuland's (2001, 2005a) approach uses features that relate to what in pre-minimalist terms one could call the A-system of the grammar. I would like to argue that such a restriction need not necessarily hold. In other words, binding relations can also be formed by features that rather belong to the A'-system. I will use the Romanian bare reflexive *sine* to substantiate this claim. First and foremost, it is a bare reflexive. Like all reflexives, *sine* is subject-oriented and it checks its agreement features against T. Second, apart from the usual ϕ feature set, I will argue that the respective bare reflexive also has a morphologically encoded operator feature which gives it quantificational properties, which will be discussed in section 2.3. The present chapter is organized as follows. In section 2, I will examine the morpho-syntactic properties of *sine* and show that this bare reflexive relates to the agreement field centered on T. This evidence is required in order to support the claim that bare reflexives check their features in the T field (hence their preference for subject antecedents). In section 3, I will briefly mention earlier attempts to analyze non-local anaphors in terms of operator binding. Section 4 will propose the specifics of my analysis. It will take on the task to explain the three descriptive generalizations about non-local binding in Romanian. In the last section, I will discuss some issues that non-local binding and successive-

132 *Analysis of the non-local binding phenomenon*

cyclic wh-movement share. I will also attempt to explain why non-local binding is sensitive only to certain kind of islands i.e. adjunct islands and relative clause islands. Summing up, the upshot of the chapter is to bring additional support to the existence of a syntactic residue of binding and to extend that residue so as to include anaphoric Probe – Goal dependencies that result in A'-dependencies.

2. *The morpho-syntactic features of sine*

2.1. Person specification

As I have already mentioned when discussing the Blocking Effect, Romanian *sine* has a person restriction. It links up only to 3rd person antecedents.

1. a. *Eu_i gătesc pentru sine_i.
I cook for self
“I cook for myself”.
- b. *Tu_i gătești pentru sine_i.
You cook for self
- c. El gătește pentru sine.
He cooks for self

2.2. Number specification

Plural antecedents for the bare reflexive are not in the least felicitous. The tests that can be employed to argue for *sine* being singular involve data from ungrammaticality with plural antecedents (cf. 2, 3) and agreement with the intensifying adjective *insusi* (cf. 5).

- **Ungrammaticality with plural antecedents.**
2. ?*Ei_i vorbeasc despre sine.
They talk about self
“They talk about themselves”.

3. ?? Piticii construiesc palate de piatră numai pentru sine?^{??}.
 Dwarves.the build palaces of stone only for self_{SG}.
 “The dwarves build stone palaces only for themselves”.

▪ **Agreement with the intensifying adjective *însuși*.**

Romanian has an intensifying adjective, *însuși*, that modifies both anaphors/pronouns and nouns and R-expressions. It is specified for gender, number and case and it has to agree with the element it modifies, as shown by (4).

4. a. Primul ministru vorbește despre el însuși.
 Prime.the minister_{MASC.SG} talks about he_{MASC.SG} himself_{MASC.SG}
 „The prime minister talks about himself”.
- b. Prim miniștrii vorbesc despre ei înșiși.
 Prime ministers.the_{MASC.PL} talk about them_{MASC.PL} themselves_{MASC.PL}
 „The prime ministers talk about themselves”

Example (5 a) is perfectly grammatical because *sine* agrees with *însuși* and with its singular antecedent, but matters stand completely different in (5 b), where *sine* is modified by plural *înșiși* and links up to a plural antecedent.

5. a. Filozoful a vorbit despre sine însuși.
 Philosopher.the_{SG} has talked about sine_{SG} self_{SG}
 „The philosopher talked about he himself”.
- b. *Filozofii au vorbit despre sine înșiși.
 Philosophers.the_{PL} have talked about sine_{SG} self_{PL}.
 „The philosophers talked about they themselves”.

Based on (2), (3) and (5), I take it that *sine* must relate only to singular antecedents. To give a full picture of the number issue, note that, *sine* must rather be semantically singular than strictly syntactically singular (for a discussion of semantic number see Winter 2002, a.o). It requires a distributive

134 *Analysis of the non-local binding phenomenon*

interpretation when construed with plural quantified antecedents, as I will illustrate below.

▪ *Sine* with quantified antecedents

The quantifier *fiecare* in (6 a) agrees with the verb in the singular and, when construed with *sine*, it gives rise to a distributive interpretation. As (6 b) shows, *sine* might also relate to quantifiers like *toți* or *mulți* that trigger plural agreement on the verb provided that the same distributive interpretation obtains.

6. a. Fiecare a vorbit despre sine.
Each has_{SG} talked about self
“Each of them talked about himself”. (distributive)
- b. Toți/mulți șefi au vorbit despre sine.
All/many bosses have_{PL} talked about self
“All/many bosses talked about themselves”. (distributive)

In case a collective predicate is involved (*împreună* added to a coordinate subject forces out a collective reading), the sentence becomes ungrammatical:

7. *George_i și Alex_j rid împreună de sine_{i+j}.
George and Alex laugh together at self
“George and Alex laugh at themselves”. (intended meaning)

The tests that I have used in this subsection might lead one to believe that *sine* does bear a grammatical [+singular] number specification because it requires singular antecedents and gets the distributive interpretation when construed with plural quantified antecedents. However, since the singular on *sine* is not determined through a grammatical opposition with a corresponding plural form (this anaphor has no plural like pronouns and nouns have), I would

rather commit to the view that *sine* is semantically singular⁴⁸, and is syntactically unspecified for number.

2.3. Morphological decomposition

Sine is part of the paradigm of strong reflexive pronouns, which I presented in Table 2, section 2.2. of Chapter 1. I will give it again here for the sake of convenience.

*The Romanian bare (simplex) reflexive paradigm*⁴⁹

Person	Accusative		Dative	
	Singular	Plural	Singular	Plural
1	mine	noi	mie, mi	nouă
2	tine	voi	ție, ți	vouă
3	sine	-	sieși, și	-

A first look at the Romanian bare reflexive reveals that it has a morphologically encoded third person morpheme *s-*, which is the same across other Romance languages paradigms. Kayne 2000 analyzes Italian *sé* and French *soi* as bi-morphemic in that they spell out the person morpheme, *s-*, and the number morpheme, *-e* and *-oi* respectively. I would like to propose that *sine* is also bi-morphemic, *si-ne*. In contrast to its Italian and French counterparts, it encodes an operator bound feature, *-ne*, in addition to the person morpheme *s(i)*-One piece of evidence to this extent comes from the etymology of this pronominal form. The *-ne* morpheme relates diachronically to the Latin

⁴⁸ This is apparently also the case for Italian *sé* (cf. Kayne 2000). Germanic SE-reflexives, like Icelandic *sig*, and Dutch *zich* represent a different case because (a) they may felicitously relate to plural antecedents and (b) when related to a plural antecedent, they may get the collective interpretation:

- (1) Zij wasten zich dagelijkes
They washed themselves daily
- (2) Alle mannen gezamenlijk wasten zich dagelijks
All men together washed themselves daily

⁴⁹ As an aside, note that the bare reflexive has no possessive (genitive) form.

interrogative enclitic *-ne* (Philippide 1894, Rosseti 1938). To be more precise, this etymological explanation claims that *-ne* in *mine*, *tine* and *sine* comes by analogy with interrogative *-ne* which also shows in the *wh*-word *cine* (who).

To sum up the morphological decomposition issue, I posit that *sine* spells out a person morpheme and an operator morpheme. The latter provides motivation for the bare reflexive to escape out of its external merge position and the lower phase in which it is initially generated. To be precise, I take the *-ne* part to be the instantiation of an operator feature.

The concept of A'-anaphor was used in the late eighties and early nineties to account for the following types of interpretive dependencies (i) the dependency between a logophoric pronoun contained in an embedded clause and its antecedent, in the main clause (Koopman & Sportiche 1989 on logophoric pronouns in Abe); (ii) the dependency between a pronominal expression contained in an embedded clause and its antecedent in the main clause (Enç 1989, Varlokosta & Hornstein 1993, on the Greek (object) anaphor *o idhios*) and (iii) the dependency between a resumptive pronoun and its antecedent (Mc Closkey 1990). What all these cases have in common, for different reasons though, is that a pronominal expression is non-locally bound to a non-local antecedent through the mediation of an operator situated in the left periphery of the clause that contains the pronominal expression. To put it briefly, the common structure to all the dependencies in (i) – (iii) looks as follows:

8. [DP_i ... [CP Op_i [c [TP ... pronoun_i]]]]

For our present purposes it is sufficient to note that the above-mentioned works show that the idea of operator features entering into the encoding of anaphoric dependencies has independent justification.

Thus, I will assume that *sine* is syntactically underspecified for number and carries an operator-feature. As I will show in the next sections, this will be enough to allow it to act as an active Goal in Probe – Goal relations. It is in particular the operator feature that is central to the explanation as to why the binding domains of *sine* exhibit the intriguing pattern we found.

2.4. Idiolectal variation with non-local binding

I have assumed all along that the intrinsic morpho-syntactic properties a lexical item has and the position in which it is introduced in the derivation will determine its set of usages. I have just proposed that the non-local bare reflexive anaphor *sine* is bimorphemic. Its *s(i)-* part is a SE anaphor (Reinhart & Reuland 1993). This part includes the third person morpheme *s-*, but carries no number and gender specification. The *-ne* part is an operator-like element, related to the *wh*-word *cine*. I have also argued that *sine*, as a whole, is semantically singular. This characteristic reflects in the fact that it can be only be interpreted distributively when it relates to plural quantified subject antecedents.

That *sine* includes an operator-like morpheme is responsible for the fact this particular anaphor can be non-locally bound (besides being locally bound). That is to say both configurations are licit:

- [DP₁ ... VP ... [CP ... [DP₂ ... VP ... [PP *sine*₂]]]] Local
- [DP₁ ... VP ... [CP ... [DP₂ ... VP ... [PP *sine*_{1,(2)}}]]]] Non-local

I have shown in Chapter 1, section 2.2., and Chapter 3 that *sine* may in fact be non-locally bound. However, note that there is idiolectal variation on this point among native speakers. Some speakers accept non-local *sine*, but others do not. To account for varying judgments, I would like to make the following proposal. For the group of speakers that do not allow for non-local *sine* the interpretable, unvalued operator feature has taken on a default value, along lines to be discussed in section 3.2.3. The anaphoric form has become, in a sense, morphologically atomic. As a result of this, *sine* becomes necessarily locally bound.

3. *The mechanism behind long distance binding*

A'-movement (the covert kind) has been previously proposed to explain non-local binding dependencies, i.e. those binding dependencies that violate the SSC. The idea benefited from diverse implementations. I will briefly list three of them in order to set up the background for my proposal.

3.1. Katada 1991

One possible way to go about it has been taken by Katada 1991 to explain the behavior of the Japanese bare reflexive *zibun*. *Zibun* can enter a non-local dependency and violate the SSC.

9. Taroo_i wa Yosiko ga zibun_i ni aitagatteiru to iwareta.
 Taroo_{TOP} Yosiko self visit-was-wanting_{COMP} was-told
 "Taroo was told that Yosiko wanted to visit him" (Sells 1987)

Katada suggests that the non-local *zibun*, which has unspecified ϕ features and is restricted to a [+human] interpretation, carries a [+op] feature. She offers semantic evidence for this proposal. More precisely, she considers that *zibun* shares with other operator-like elements like *wh*-words and quantifiers the property of having a semantic range. Katada understands range to be the restriction that *zibun* refers only to [+animate], [+human] entities. Similarly, *who* refers to the same kind of entity. However, she believes that *zibun* does not have quantificational properties per se, and needs an antecedent to get its reference (on the assumption that anaphors need to make up for their referential deficiency). Due to its [+op] specification, *zibun* undergoes covert A' movement at LF and adjoins at the VP-level first in the embedded clause and then in the next clause up. This adjunction movement does not obey any locality constraints, so it is possible for *zibun* to adjoin to the first available VP and from then on to the next VP/clause. This movement can proceed with some supplementary assumptions about how to void IP barrierhood while moving from an embedded clause to the next clause up (the precise details can be found in Katada's paper). An analysis along this line is faced with the problem of how to explain the fact that *zibun* is different from other reflexive anaphors that also have the [+ human] restriction (such as English *himself*, and the Germanic SE-anaphors), but do not have the binding freedom *zibun* has⁵⁰. Apart from this,

⁵⁰ Note that the first person pronoun *I* is restricted to [+ human] entities as well. The question is whether that does necessarily make it quantificational. It is true that it has been argued quite extensively that first and second person pronouns may exhibit bound variable behaviour (Schlenker 2003 a, Rullmann 2001, Anand & Nevins 2004, Kratzer 2006, a.o.).

there remains the problem created by postulating an unbounded dependency, since, in minimalist terms, movement necessarily proceeds in a phase-based fashion and has to be motivated in terms of checking features in Probe – Goal relations.

3.2. Koopman & Sportiche 1989

Another possibility, which is more easily accountable in a minimalist way of thinking and which I have already mentioned in section 1.3, has been offered by Koopman & Sportiche 1989. Below I will propose an analysis that is, in certain ways, similar to what Koopman & Sportiche propose.

3.3. Chierchia 1989

Chierchia 1989 argues that non-local anaphors are bound by a particular type of operator that adjoins either at VP or at CP level. This operator necessarily imposes a *de se* interpretation on the variable that it binds. In its turn, it has to be assigned range, so it is the matrix clause subject which does that. Non-local anaphors relate to their subject antecedents by the mediation of such an operator.

10. Pavarotti_i crede O_i [che i propri_i pantaloni sono in fiamme].
 Pavarotti believes that self pants are on fire
 Believe (P, λx (x's pants are on fire))

Note however that, as Chierchia himself acknowledges, operator bound pronouns can also get a *de se* interpretation. This detail wipes away the difference between non-local anaphors, on one hand, and pronouns, on the other hand. The possibility of the operator to appear depends on the type of matrix predicate, i.e. if it is a propositional attitude verb. If the respective predicate is such that its subject can take on the role of perspective holder, and license a *de se* reading, nothing prevents the operator from binding pronouns as well.

140 *Analysis of the non-local binding phenomenon*

11. a. John_i thinks O_i [that Mary is still wondering [whether to marry him_i]]
b. Bill_i believes O_i [that the fact that people like him_i is a miracle]

Pronouns that are bound through the mediation of an operator and get the *de se* reading will also allow for the sloppy interpretation. This kind of operator binding illustrates in fact the semantic notion of binding, which I have discussed in Chapter 3. It is too permissive to capture the Romanian data. Let me spell out the main reason for believing this.

Since non-local anaphors are known for their capacity to escape island effects, Chierchia's analysis is formulated in such a way as not to involve movement and to capture thus the absence of island effects. In my discussion on islandhood and non-local anaphors from Chapter 3, section 5.3, I have noted that the type of non-local binding under scrutiny here is not completely exempt of islandhood effects. More precisely, I have mentioned that non-local binding is blocked out of adjunct islands and is marginally acceptable out of relative clauses. Apart from the problems created by postulating the existence of an operator in a derivation that is strictly governed by narrow syntactic considerations, an approach along Chierchia's line will leave unexplained the island facts because there is no ban on operators adjoining to adjunct clauses, for instance. Note, additionally, that operator binding of the type Chierchia proposes cannot explain why pronouns that get a *de se* reading are perfectly grammatical when bound out of the adjunct island (12 b), but bare reflexives are not (12 a).

12. a. *Fiecare băiat_i se înfurie când sora lui râde de sine_i.
Each boy SERFL.CL infuriates when sister his laughs at self
"Each boy gets angry when his sister laughs at himself".
b. Fiecare băiat_i se înfurie când sora lui râde de el_i.
Each boy SERFL.CL infuriates when his sister laughs at him
"Each boy gets angry when his sister laughs at him".

The conclusion of this brief survey of the existing analyses of non-local binding in terms of covert A'-movement or operator binding is that any account that cannot motivate the presence of a purported operator feature on a non-local

anaphor and that cannot contain within syntactically constrained limitations the movement that is supposed to relate the non-local anaphor to its antecedent cannot satisfy the rigours of a minimalist, efficient computation and needs reconsideration.

In section 4, I will start by laying out a set of theoretical assumptions in line with the Inclusiveness Condition and with all the restrictions that regulate Probe – Goal relations. I will then make use of them to offer an implementation of how an A'-dependency resulting from Agree can correctly capture the non-local binding facts of Romanian.

4. *The proposal of this dissertation*

I would like to argue that the Romanian non-local binding data can find an account in strict minimalist terms provided certain assumptions about Agree, the relation between feature valuation and interpretability, feature typology, and the properties of A' chains are adopted. I will begin by introducing these assumptions, which, in fact, are not new and have been discussed in the literature (cf. Pesetsky & Torrego 2004, Rizzi 2004, Rizzi and Shlonsky 2005). Then I will move on to give a detailed analysis of the data and explore its consequences.

4.1. Necessary assumptions

Assumption (i): Agree involves feature sharing.

Pesetsky & Torrego 2004 argue for a different way to think of Agree than the one put forth in Chomsky 2000, 2001. They propose a conceptualization of Agree in terms of feature sharing.

13. *Agree (Feature sharing version)*
 - (i) An unvalued feature F (a probe) on a head H at syntactic location α ($F\alpha$) scans its c-command domain for another instance of F (a goal) at location β ($F\beta$) with which to agree.
 - (ii) Replace $F\alpha$ with $F\beta$, so that the same feature is present in both locations (Pesetsky & Torrego: 4)

On this view a Probe with an unvalued feature will search for a match on a Goal, which has the valued instance of the respective feature and value its feature. The result of the valuation is that the same feature, *F*, will show up on both the Probe and the Goal. The novelty is that Agree does not end when the unvalued feature on the Probe has been valued by the Goal. The valued feature on the Probe gets to survive and may enter a further Agree relation, triggered by a higher probe with an unvalued feature. The output will be that three locations end up sharing the same feature. The authors suggest that this procedure is iterative.

Assumption (ii): valuation divorces from interpretability.

There is another important issue on which Pesetsky & Torrego differ from Chomsky 2000, 2001 and it concerns the relation between interpretability and valuation. For Chomsky, the two are interconnected in that an uninterpretable feature has to be unvalued as well. Syntax has the ability to detect unvalued features on probes and it requires of them to be valued and deleted within the C_{HL} . Interpretability of features comes as the direct result of them being valued. Pesetsky & Torrego propose to dispense with conditioning interpretability on valuation. If interpretability divorces from valuation, the dual feature typology proposed by Chomsky (i.e. valued versus unvalued) can be enriched and extended so as to include the following combinations (options (i) and (iv) are completely new; both combinations act as probes):

14. Feature typology
 - (i) uninterpretable, valued (uF val)
 - (ii) uninterpretable unvalued (uF [])
 - (iii) interpretable, valued (iF val)
 - (iv) interpretable, unvalued (iF [])

There is empirical support to justify the necessity of the two new combinations. For instance, Pesetsky & Torrego argue that the tense feature on the T heads of finite clauses instantiates the interpretable and unvalued type. The same tense feature on *v* represents the uninterpretable valued type. So far, I have listed the assumptions concerning Agree, interpretability and valuation and feature typology. In what follows, I will focus on the properties of A' chains (Rizzi 2004, Rizzi and Shlonsky 2005).

Assumption (iii): A' chains involve a selectional and a criterial position.

Criterial positions are associated with the checking of features related to the left periphery heads (i.e. topic, focus, +wh). The s-selection (semantic selection) position is the position in which a lexical item is merged in order to have its theta requirements met (its subcategorized position). I will take it for granted that A' chains include one criterial position and one s-selection position. I will illustrate this point with an example that involves *wh*-movement.

15. Which book did you say that you had read <which book>

The *wh*-phrase merges first in the internal argument position selected by the verb *read* and receives a theta role from the V head. This is its s-selection position. Subsequently, it moves into the Spec, C position in order to check the *wh*-feature on the C head. This is its criterial position. Rizzi argues that formal (pseudo) counterparts of the features in criterial positions that drive movement reside in the intermediate steps through which movement proceeds (reference on this). This amounts to saying that the embedded clause in (15) above hosts a pseudo-criterial feature and the matrix left periphery has the “real” criterial feature. Pseudo-criterial features are not associated with any interpretive property.

Assumption (iv): movement proceeds on a phase basis.

The received view has always been that movement must be local and cannot take place in one swoop from the s-selection position to the criterial one (Rizzi 2002, 2004, a.o). Rizzi enumerates quite a few cases which clearly indicate that intermediate positions exist and I refer the reader to his paper. I only want to mention evidence of Romanian stylistic inversion of subjects in cases of successive cyclic *wh*-movement (see also Comorovski 1986)⁵¹.

16. a. Ce declarație susține George [că a făcut <ce declarație> președintele]?
What statement claims George that has made.pro president.the
“What statement does George claim that the president made?”

⁵¹ I will return to this issue in section 5.

144 *Analysis of the non-local binding phenomenon*

- b. *Ce declarație susține George [că președintele a făcut <ce> declarație]?
 What statement claims George that president.the has made

The direct object of the embedded verb, *a face*, has undergone *wh*-movement to the Spec, TP of the matrix clause (cf. 16 a). In this case, the subject of the embedded clause must remain in situ. The ungrammaticality of (16 b), with the subject in pre-verbal position, confirms this restriction. It has been claimed, and I endorse this view, that *wh*-movement to the left periphery of the embedded clause forces the subject to stay in situ. This suggests that the embedded left periphery hosts an intermediate landing site for the *wh*-word.

Assumption (v): split ϕ feature checking is possible.

Features in complex phrases that undergo movement might end up splitting and being checked in different positions. I will argue that this is exactly the case with the feature checking involved in Romanian non-local binding contexts.

The following table resumes for convenience all the seven assumptions on which I base my analysis.

1	Agree involves feature sharing
2	ϕ feature valuation is divorced from ϕ feature interpretability
3	A' chains have an s-selection and a criterial position
4	Movement proceeds in a phase-based fashion
5	Split ϕ feature checking is possible

4.2. The analysis at work

Let us first see what happens when there is no intervener to block the non-local dependency. Consider (17) and its representation (18).

17. George_i crede că Alex_j contează pe sine_{i, j}.
 George believes that Alex counts on self
 "George believes that Alex counts on Alex/George".

18.

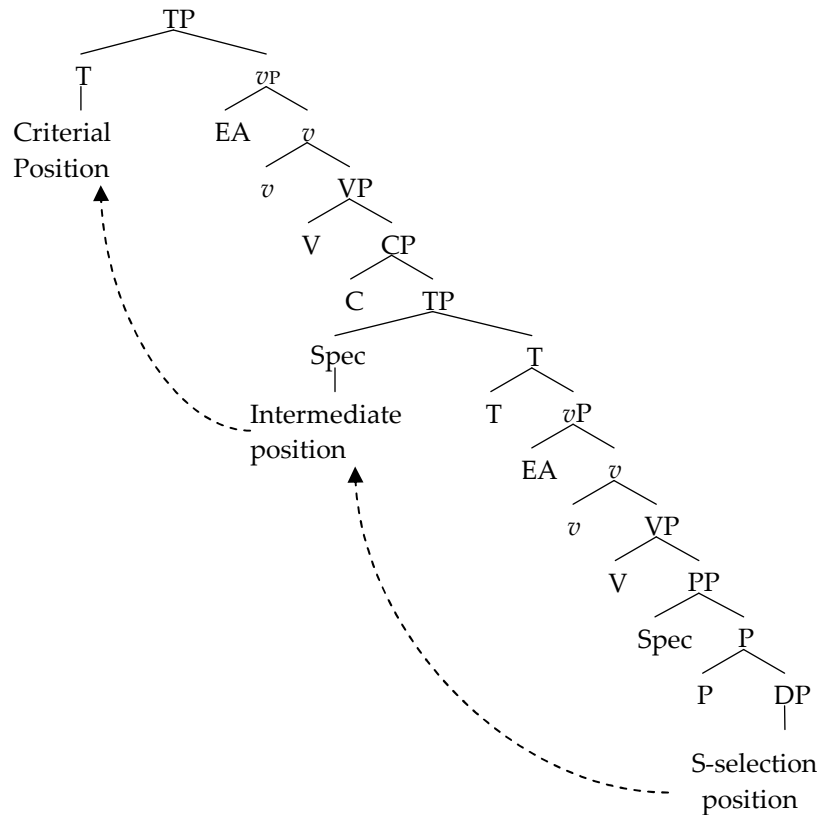

Let us focus now on the derivation walkthrough for (17) starting with what happens in the embedded clause. I will begin by listing all the types of features that the relevant heads and complements bring into the derivation from the Lexicon and then consider the external and internal merge procedures that have applied.

What goes in the derivation is listed below.

- v has an uninterpretable, valued Tense feature
- T has interpretable, unvalued Tense feature
- DP subject has interpretable, valued ϕ features, i.e. person, number, gender and also an uninterpretable, unvalued T feature (i.e. nominative case)

146 *Analysis of the non-local binding phenomenon*

- DP-prepositional object *sine* has interpretable, valued ϕ features, i.e. person (an empty slot is allocated for number and gender) and also an interpretable, unvalued operator feature

This is how the derivation proceeds.

- P merges with the DP-prepositional object. The accusative case and the theta role on the DP get checked by P.
- V merges with PP
- *v* merges with VP
- DP-subject merges in the Spec,*v* and gets its theta-role
- The EPP feature of *v* probes *sine*, and links it to the outer Spec, *v*. This results in an Agree link. Note that an Agree relation without movement is enough (Rezac 2004 on the proposal that Agree involves feature transfer).
- T merges with *v*P. It probes and finds the external argument (EA), which values its uninterpretable ϕ features. It sets up a link with the external argument.
- V raises overtly to T, via *v*. T will probe the [V-*v*] complex that has adjoined to it, it will detect the *v* head and value its tense feature.
- EPP of T attracts *sine* (*sine* and the external argument are equidistant from T; *sine* gets to be attracted because it bears the operator feature that the external argument does not have and will, therefore, be targeted for this operation). It can do that because it is associated with discourse-related properties (see assumption (vii) above). In accordance with the assumptions about pseudo criterial features located in intermediate movement sites, this EPP position bears the formal features that correspond to the criterial position located in the left periphery of the matrix.

The phrase marker in (19) sums up how the derivation looks like at the point when the embedded clause is ready to be spelled-out (the tree marks the relevant positions of the feature of *sine*):

19.

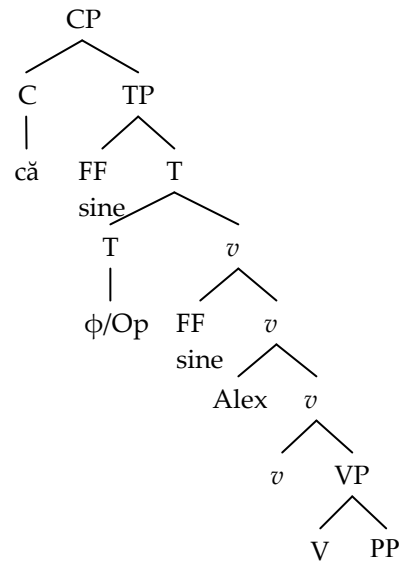

Let us see now how the derivation continues in the matrix clause.

- C merges with the embedded TP. There is correspondence between C and T in the sense that both host agreement/discourse related features.
- Matrix V merges with CP ... and so on and so forth until ...
- Matrix T merges with *v*P
- *v* has an uninterpretable, valued T feature (as above)
- T has interpretable, unvalued T feature (as above)
- DP subject has interpretable, valued ϕ features, i.e. person, number, gender and also an uninterpretable, unvalued T feature (i.e. nominative case)
- T probes and finds the external argument, which values its uninterpretable ϕ features. It sets up a link with the external argument. It checks its unvalued tense feature by probing into the adjoined [V-*v*] complex (as above). It also has an uninterpretable, valued operator feature on it, which sees the operator feature on *sine*.

I will conclude this section by making an additional remark about non-local binding and recursiveness. Note that further embedding of standard non-local

148 *Analysis of the non-local binding phenomenon*

structures such as (20) will rule out linking *sine* to the highest available antecedent, as indicated below.

20. Seful_i suspectează că George_j crede că Alex_k contează pe sine^{i, j, k}.
Boss.the suspects that George believes that Alex counts on self
“The boss suspects that George believes that Alex counts on Alex/George/*the boss”.

Contrast (20) to (21), which involves pronoun binding.

21. Seful_i suspectează că George_j crede că Alex_k contează pe el_{i, j, k}.
Boss.the suspects that George believes that Alex counts on him
“The boss suspects that George believes that Alex counts on Alex/George/the boss”.

The explanation for this contrast has to do with the manner in which features are checked. My proposal has been that *sine* goes through split feature checking, i.e. first the ϕ set, then the operator feature. Once this checking has applied, the bare reflexive has used up all its features, and cannot enter further relations. This restriction gives the ungrammaticality of the highest subject in (21) as an antecedent for *sine*.

4.2.1. Deriving descriptive generalization 1

Let me now move on to explain the first descriptive generalization I mentioned at the end of Chapter 3. I repeat it below just to freshen up the reader’s memory.

Descriptive generalization (1): Romanian non-local binding dependencies are sensitive to relativized minimality effects.

Subject (animate) *wh*-words antecedents block non-local binding. To better understand how exactly this intervention effect comes about, I will resort first to a comparison with *wh*-movement. Romanian has multiple *wh*-movement (cf. 22 a, 23 a). *Wh*-movement is sensitive to superiority effects (cf. 22 b, 23b).

22. a. Cine ce a făcut?
Who what has done
- b. ?*Ce cine a făcut?
What who has done
23. a. Ce când ai cumpărat?
What when have.you bought
- b. ?*Când ce ai cumpărat?
When what have.you bought

I assume that multiple *wh*-movement involves tucking in (Richards 1997). For instance, the direct object, *ce*, in (22 a) tucks in under the subject, *cine*. If a sentence like (22) is further embedded⁵², it is possible to further extract the *wh*-subject, but extraction of the *wh*-object is less felicitous.

24. a. Cine se întreabă George ce a făcut?
Who SREFL.CL asks George what has done
“Who does George wonder what he did?”
- b. ?*Ce se întreabă George cine a făcut?
What SREFL.CL asks George who did
“What does George wonder who did?”

I suggest something similar is at work with the non-local binding case. Consider (25), and its schematized representation (26).

25. George_i știe cine_j contează pe sine_{i,j}.
George knows who counts on self
“George knows who counts on himself / George”.

⁵² Admittedly, further embedding (22 a), as in (23 a) will yield a slightly deviant construction, i.e. a *wh*-island. However, (24 a) is still a possible sentence to produce.

150 *Analysis of the non-local binding phenomenon*

The *wh*-subject merges initially in Spec, *v*, its argument position. Then it is attracted to Spec, T to satisfy its [+wh] feature. It moves overtly. As a result, the operator feature in T is checked against the [+wh] feature of the *wh*-subject. The operator part of the bare reflexive is probed by the T head as well. An Agree relation is set up and, as a result, the bare reflexive values its relevant interpretable, but unvalued, operator part⁵³. The crucial claim is that the operator feature of *sine* is sensitive to the intervention of a *wh*-element. An intervening *wh*-element breaks the Agree-chain between *sine* and the probing matrix T (if the chain had been established, the non-local reading would have been licensed). The break in the Agree chain comes from the fact that the operator part of the bare reflexive remains too deeply embedded to be probed by matrix T.

⁵³ Note that combinations of overt and covert *wh*-movement are possible in questions that elicit pair-list answers.

- (1) Care băiat a pus care întrebare? overt + covert
Which boy has posed which question
“Which boy posed which question?”
Care băiat care întrebare a pus-o? multiple wh-question (all overt)
Which boy which question has posed.he it
“Which boy which question posed?”

26.

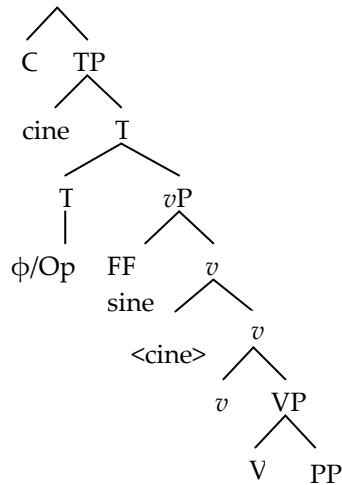

The claim is now that all quantificational expressions give rise to similar intervention effects. Consider first the pair in (27).

27. a. All women think that John bought two books.
 b. All women wonder who bought two books.

Two books can take either narrow scope or wide scope with respect to *all women* in (27 a). Not the same holds for (27 b), where there is a *wh*-intervener, *who*. The narrow scope reading obtains, but the wide scope one is impossible. In other words, it is impossible to paraphrase (27 b) as *for which x, x being two certain books, do all women wonder who bought x*. Again, I propose that the principle underlying this phenomenon is the same one that explains the intervention effects of quantified antecedents on non-local binding, shown in (28).

28. George_i știe că orice om_j contează mereu pe sine_{i,j}.
 George knows that any man counts always on self
 "George knows that any man always counts on any man/George".

152 *Analysis of the non-local binding phenomenon*

The non-local reading in (28) is blocked, on a par with the wide scope reading for the indefinite in (27 b).

4.2.2. Deriving descriptive generalization 2

The descriptive generalization I proposed at the end of Chapter 3 is repeated below.

Descriptive generalization (2) Romanian non-local anaphoric dependencies only 'escape' FULL clauses; small clauses block these dependencies.

Let me give again the relevant minimal pairs, (29 a-b) and (29 c-d)

29. a. George_i l-a auzit pe Alex_j rîzînd de sine^{*_{i,j}}.
George him_{CL.ACC} has heard on Alex laughing_{GER} at self
"George heard Alex laughing at Alex/George".
- b. George_i a auzit că Alex_j ride de sine_{i,j}.
George has heard that Alex laughs at self
"George heard that Alex laughs at Alex/George".
- c. Alex_i îl consideră pe George_j încrezător în sine^{*_{i,j}}.
Alex him_{CL.ACC} considers on George trusting in self
"Alex considers George to be self-trusting".
- d. Alex_i consideră ca George_j are încredere în sine_{i,j}.
Alex considers that George has trust in self
"Alex considers that George has trust in George/Alex".

4.2.2.1. Hypothesis

The reader knows by now that *sine* has agreement features and an interpretable, unvalued operator related feature. I would like to propose now that two options of valuing the operator related feature exist. The first one is that this feature takes on the default value because defective T is the Probe

(empirically, the defectiveness of T manifests itself in a reduced or absent left periphery associated with the respective T). The second one is that the operator related feature gets valued by a fully specified T probe (this T probe is associated with a full-fledged left periphery). I will discuss both options in detail.

4.2.2.2. Understanding the notion of defective Probe

Chomsky 2001 discusses the notion of defective Probe: “*E is defective, differing in some respect from otherwise identical active elements that induce deletion. The simplest way to express the distinction, requiring no new mechanisms or features, is in terms of (3b): a non-defective probe is ϕ complete, a defective one is not*” (p. 6). He is interested in participial forms that, in some languages, agree partially with their objects in terms of ϕ features, but not in case. I retain the idea that Probes may be defective and propose that gerund forms in Romanian instantiate defective Probes.

I propose that the deficiency of gerund T lies in the fact that it does not host an operator feature. I further relate this deficiency with the absence of a fully-fledged left periphery. More precisely, gerund clauses have a reduced left periphery. The left periphery is not entirely absent, because clitic left dislocation can occur in these clauses, as (30) shows (the italics mark the clitic left dislocated object and the object clitic that is left behind).

30. Acestia își bătuseră cumnatul fiindcă nu era un om serios
 Those.people their_{POSS.CL} had beaten the brother.in.law because not
 was.he a man serious
 care să-și vadă de casă, *toți banii* cheltuindu-*i* numai pe băutură.
 who takes care of home, all money spending.he_{GER} them_{CL.ACC} only on
 booze
 “Those people had beaten up their brother in law because he was not a
 serious man, who takes care of his household, having spent his money
 on booze”.

Clitic left dislocation to the left periphery of infinitive clauses (also non-finite) is also possible in Italian as noted by Rizzi 1997 (Rizzi also remarks that CLLD happens when the infinitive is introduced by the prepositional complementizer *di*, which makes matters different from the Romanian (30)).

154 *Analysis of the non-local binding phenomenon*

31. Credo, il tuo libro, di apprezzarlo molto.
I.belong, your book, di to.appreciate it much.

The left periphery of gerund clauses must be taken to be reduced, though, since, crucially, it cannot host *wh*-words, as shown below⁵⁴.

32. a. *Am văzut politicieni importanți [ce facînd t_{CE}]?
Have.I seen politicians important what doing
“I saw important politicians what doing?”
- b. *Am văzut procurori [care cazuri investigînd t_{CARE CAZURI}]?
Have. I seen prosecutors which cases investigating
“I saw prosecutors which cases investigating?”

I would like to propose that for non-local binding to work, the position that hosts *wh*-words would be necessary. In this sense, the gerund T has no operator feature. I will go along with Rezac 2002 and assume that Probes must “do their best” to check the features on the Goals in their complement domain before new elements, which can act as Probes, are introduced in the derivation:

⁵⁴ Wh echo-questions, with the *wh* element in situ, are, of course possible. However, it is generally acknowledged that echo questions do not involve movement to the left periphery.

- (1) a. Am văzut politicieni importanți [făcînd CE]?
Have.I seen politicians important [doing WHAT]
b. Am văzut procurori [investigînd CARE CAZURI]?
Have. I seen prosecutors [investigating WHICH CASES]

I want to raise an additional point concerning the nature of the left periphery of gerund clauses. In Rizzi’s cartographic approach to the left periphery, CLLD elements occupy a higher position than *wh*-words. The ordering CLLD > WH applies for Romanian as well.

- (2) Banii, cine i-a aruncat pe fereastră?
Money.the, who them cl has thrown out.of window.the
“The money, who threw it out of the window?”

A possible way out would be to assume that CLLD involves merge of the left dislocated object in its surface position, with the clitic acting like a sort of resumptive pronoun. This obviously amounts to rejecting a movement analysis of CLLD.

33. *Properties of the probe/selector a must trigger associated syntactic operations before new elements of the lexical subarray are accessed to drive further operations* (Rezac 2002: 9).

4.2.3. The operator gets the default value

4.2.3.1. The case of ECM with defective T

34. [C DP1 T v [DP2 T DEF sine ($i\phi$, uOp)]]

To explain the local reading in ECM clauses with gerund predicates⁵⁵, I will resort to two assumptions, which I have already introduced and which I repeat in what follows for the sake of clarity. First, *sine* needs to check both its agreement and its operator feature. Second, deficient T heads do not have a left periphery or they have a reduced one. This entails that deficient Ts do not have the relevant operator feature that is necessary for licensing (i) non-local binding and (ii) *wh*-phrases in the left periphery. I think this difference between gerund Ts and those Ts that are associated with a fully-fledged left periphery is crucial for the non-local binding phenomenon I am concerned with.

The bare reflexives checks its ϕ features against the deficient gerund. Since the gerund T has no operator feature and therefore cannot probe and attract the operator feature on the bare reflexive, the latter will get a default value. Note that the operator feature on *sine* enters the derivation with an interpretable and unvalued operator feature. Since the feature is interpretable it need not necessarily get checked in order to satisfy the requirements of the Full Interpretation principle. Therefore, in order to make this case compatible with the conditions on Agree chains in Pesetsky and Torrego 2004, I posit that the unvalued operator feature can get a default value.

⁵⁵ This account will also carry over to those ECM verbs that select an infinitival complement.

4.2.3.2. The case of ECM with adjectival predicate

35. [CDP1 T v [DP2 A sine ($i\phi$, uOp)]]

The local reading in small clauses will follow in a similar way with the gerund story if one takes small clauses to be the projection of a defective T (Starke 1995). Note that, in contrast to gerunds, small clauses have no left periphery whatsoever (Shlonsky 2004). The non-local anaphor simply enters Agree with the T head and gets its agreement features checked. The interpretable, but unvalued operator feature will get the default value following the argumentation I have presented in the previous section.

4.3. *Deriving descriptive generalization 3*

Descriptive generalization (3): Romanian non-local anaphoric dependencies are sensitive to the blocking effect, BE.

Let me start by refreshing the reader's memory. In Chapter 3 I have given a brief presentation of the Blocking Effect. I have mentioned that Cole & Sung 1994 have proposed an analysis of the BE effect in Chinese that involves successive cyclic LF movement. Bare reflexives covertly move and adjoin to T. They check their agreement features against the subject in Spec, T. Cole & Sung assume that T in Chinese does not carry any ϕ feature specification. Cole & Sung's analysis predicts that the Blocking Effect will not hold in Germanic and Romance languages. These are languages with agreement features in T. As discussed in Chapter 3, and here illustrated with examples (36), (38) and (40), Romanian does display Blocking effects, contrary to Cole and Sung's predictions:

36. Alex_i știe că eu_j am spus că Maria_k trăiește numai pentru sine^{*_{i,j,k}}.
 Alex knows that I have said that Mary lives only for self
 "Alex knows that I said that Mary lives only for herself".

37. Alex_i știe că Paul_j a spus că Maria_k trăiește numai pentru sine^{??i,j,k}.
Alex knows that Paul has said that Mary lives only for self
“Alex knows that Paul said that Mary lives only for herself”.
38. George_i a înțeles că tu_j ai susținut că Maria_k râde
George has understood that you have claimed that Maria laughs
mereu de sine^{i, *, k}.
always at self
“George understood that you had claimed that Maria always laughed
at herself”.
39. George_i a înțeles că un prieten_j a susținut că Maria_k râde
mereu de sine^{??i, j, k}.
George has understood that a friend has claimed that Maria laughs
always at self
“George understood that a friend claimed that Maria always laughed
at herself/a friend/George”.
40. Stefan_i visează ca tu_j să vezi în sine^{i, *, j} un erou neînfricat.
Stefan dreams that you să_{SUBJ} see in self a hero brave
“Stefan is dreaming that you see in himself a brave hero”.
41. Stefan_i visează ca tatăl lui_j să vadă în sine^{i, j} un erou neînfricat.
Stefan dreams that father.the his sa_{SUB} see in self a hero brave

The descriptive observation that we can formulate at this point is that *sine* might relate to a sequence of third person antecedents⁵⁶ (cf. 40, 42 and 44) if no intervening first (or second) person antecedents breaks the sequence (cf. 37, 39, 41). Before turning to an analysis of the BE in Romanian, I will discuss to what extent the type of BE that Romanian displays carries more restrictions than the blocking patterns that have been observed for Chinese. In the next section, I will look into the similarities and differences that are reflected in the blocking

⁵⁶ Note that the more possible antecedents there are, the more difficult the processing of these complex structures become. This is why I used two question marks on the matrix subject antecedent.

patterns in these two languages and try to draw some conclusion about what exactly is it that characterizes the BE in Romanian.

4.3.1. Chinese and Romanian blocking patterns: a comparison

First, it is important to understand the specific lexical properties of Chinese *ziji*. *Ziji* is unspecified for number and person. In other words, all binding configurations listed in (42) are grammatical:

42. [DP 1st person]_i *ziji*_i
 [DP 2nd person]_i *ziji*_i
 [DP 3rd person]_i *ziji*_i
 [DP - Plural]_i *ziji*_i
 [DP + Plural]_i *ziji*_i

Now, generally speaking, both person and number mismatches trigger the BE in Chinese. Let us consider each case. When it comes to person, a 1st or 2nd person subject antecedent that intervenes between two 3rd person antecedents induces the BE. Consequently, Chinese *ziji* will be construed with the closest available 3rd person antecedent. This pattern is shown below in (43).

43. a. 3rd person_i ... 1st/2nd person_j ... 3rd person_k ... *ziji* ^{*_{i,j,k}}
 b. 3rd person_i ... 1st/2nd person_j ... *ziji* ^{*_{i,j}}

However, if the 1st or 2nd person does not intervene between two 3rd persons, blocking does not arise. I have in mind the configuration in (44) illustrated with the examples in (45) that belong to Huang and Liu 2001:

44. 1st person/2nd person_i ... 3rd person_j ... *ziji*_{i,j}
45. a. Wo_i danxin Zhangsan_j hui piping *ziji*_{i,j}
 I worry Zhangsan will criticize self
 “I am worried that Zhangsan will criticize me/himself”.

- b. Ni_i danxin Zhangsan_j hui piping ziji_{i,j} ma?
 You worry Zhangsan will criticize self _o?
 “Are you worried that Zhangsan will criticize you/himself”

As for number, a local plural antecedent does not block construal with a remoter singular antecedent (see 46), but a local singular antecedent prevents *ziji* from relating to a remoter plural one (Huang & Liu 2001):

46. Lisi_i zhidao tamen_j chang piping ziji_{i,j}.
 Lisi know they often criticize self
 “Lisi knows that they often criticize him/themselves”.
47. Tamen_j zhidao Lisi_i chang piping ziji_{i,j}.
 They know Lisi often criticize self
 “They know that they often criticize himself/them”.

The following blocking pattern emerges thus from (46) and (47):⁵⁷

48. a. singular_i ... plural_j ... ziji_{i,j}
 b. plural_i ... singular_j ... ziji_{i,j}

Romanian *sine* is different from Chinese *ziji* in the sense that *sine* is specified for person, third person, and seems to be semantically specified for singular. Now, Romanian *sine* shows only the kind of BE illustrated in (49) and (50).

49. George_i crede că eu_j contez pe sine_{i,j}.
 George believes that I count on self
 “George believes that I count on me/himself”.
50. a. George_i crede că ei_j contează pe sine_{i,j}.
 George believes that they count on self
 “George believes that they count on themselves/himself”

⁵⁷ Note that in Chinese long distance *ziji* does not need to relate only to subject antecedents. Non-subjects are also available and they may equally trigger blocking.

160 *Analysis of the non-local binding phenomenon*

- b. Primul ministru_i suspectează că toți au uitat de sine^{*_{i,j}}.
Prime minister.the suspects that all_{PL} have forgotten about self
“The prime minister suspects that all have forgotten about himself”.

The patterns in (43) and (48 a) are not possible because first person antecedents as well as plural ones are not an option for *sine*. So, the BE for Romanian can quite simply be summarized as in (51):

51. a. 3rd person _i ... 1st/2nd person ... sine^{*_i}
b. singular_i ... plural_j ... sine^{*_i}

4.3.2. An outline of a BE analysis for Romanian

Earlier in the present chapter I have argued that Romanian *sine* as a bare reflexive anaphor interacts with agreement in the T (just because of its feature composition). I would like to propose that the Blocking Effect straightforwardly follows as the result of disagreement between the features on the long distance reflexive and the features in the Tense head, as shown by the phrase marker in (53).

52. *George_i știe că eu_j contez pe sine^{*_{i,j}}.
George knows that I count on self
“George knows that I count on himself”.

Note that the once the features of *sine* have been attracted to by the EPP feature of *v*, they are further attracted to Spec, T by the operator part of T. Blocking may arise in this particular configuration, as discussed in detail below.

53.

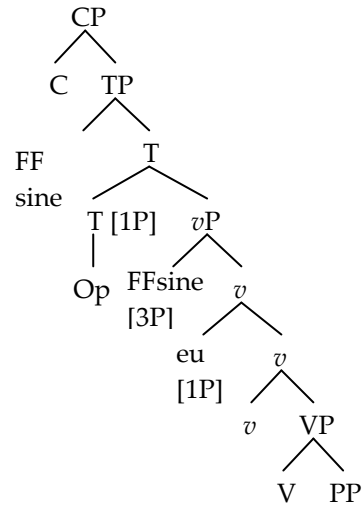

The EPP of T attracts *sine* (*sine* and the external argument are equidistant from T; *sine* gets to be attracted because it bears the operator-related feature that the external argument does not have and will, therefore, be targeted for this operation). We have to be clear now about what precisely goes wrong in case *sine* has a distinct person feature from the feature set on T. It cannot be the case that the general process of Agree really tries to incorporate the ϕ -features in the intermediate position in the Pesetsky & Torrego style Agree-chain to be formed. This would make no sense in the case of a non-blocking subject as in *George_i crede ca Maria conteaza pe sine_i* (*George believes that Maria counts on Maria/George*) where including the features of *Maria* would yield an inconsistent chain (combining the features masculine and feminine). Rather we will have to assume that, as the initial part of the operation of Agree, the computational system blindly performs a purely formal feature check in those configurations that qualify as *checking configurations* in the sense of Chomsky 1995. When the features of *sine* raise to the intermediate T, they are precisely in such a checking configuration. The check yields a mismatch, and the BE follows. Note, that it is important that the check be just formal, and involves only those features that enter subject-verb agreement. The gender feature does not, hence is ignored in this check.

162 *Analysis of the non-local binding phenomenon*

Note that an analysis of the BE along this line comes closer to the explanation proposed by Cole & Sung for Chinese. They put the BE down to person mismatch between the person feature on the subject in Spec, T and the person feature on T. Remember that in a language like Chinese, which lacks subject – verb agreement, T inherits its entire ϕ feature set from the bare reflexive that adjoins to it (in the long distance binding configuration). Cole & Sung’s analysis of the BE makes two very important predictions. The first is that the BE arises at the point when the long distance anaphor ends up in the T head and has to check its features in the T field. The second is that the BE should hold only in those languages that lack subject – verb agreement and allow therefore for T to get its ϕ set from a lexical item that has adjoined to it. I retain the view that BE comes down to ϕ feature mismatch (person or number).

My account yields a different prediction. The BE is not directly dependent on the absence of subject-verb agreement. Rather it may arise also in languages with rich subject-verb agreement. But in the latter type languages only in those cases where (the feature set of) the NLA passes through a position where it is in a checking configuration with the intermediate T.

I would therefore like to suggest that the BE in Romanian constitutes evidence that successive – cyclic A’-movement of the anaphor has applied. The BE marks that there is an intermediary (pseudo-criterial) position for this movement. This idea falls in line with the fact that A’-movement involves the presence of intermediary landing sites (subject inversion occurs when *wh*-movement or focus movement has applied, as I will discuss below).

5. *Further remarks*

5.1. **Long distance binding and successive cyclic movement**

The type of non-local binding I have discussed relies on successive cyclic movement. The presence of the discourse-related EPP feature on the embedded clause, which probes the bare reflexive, provides the necessary (intermediary) transit point. Independent evidence for the existence of intermediary points comes from successive cyclic *wh*-movement in Romanian, which leaves a reflex at every transit point, i.e. in every intervening Spec, T, as shown in (54) and (55) below. Example (54) shows *wh*-extraction of the direct object in the lowest embedded clause. When this extraction takes place, the

embedded clause subject as well as the subject in the middle clause and the matrix subject must remain in situ, i.e. in their external merge position. This happens in (54), but not in (55 a), where the most embedded subject moves to pre-verbal position or in (55 b), where the middle clause subject moves to pre-verbal position or in (55 c) where the matrix subject leaves its *vP* internal position.

54. Ce crezuse polițistul [că îi spusese falsul clovn
 What believed policeman.the that to him said fake.the clown
 [că furase îmblinzitorul de tigri <ce>]]?
 that stole the tamer of lions?
 “What did the policeman think that the fake clown had told him that
 the lion tamer had stolen?”
55. a. *Ce crezuse polițistul [că îi spusese falsul clovn
 What believed policeman.the that to him said fake.the clown
 [că îmblinzitorul de tigri furase <ce>]]?
 that the tamer of lions stole?
 “What did the policeman think that the fake clown had told
 him that the lion tamer had stolen?”
- b. ?*Ce crezuse polițistul [că falsul clovn îi spusese
 What believed policeman.the that fake.the clown to him said
 [că furase îmblinzitorul de tigri <ce>]]?
 that stole the tamer of lions?
 “What did the policeman think that the fake clown had told him
 that the lion tamer had stolen?”
- c. *Ce polițistul crezuse [că îi spusese falsul clovn
 What policeman.the believed that to him said fake.the clown
 [că furase îmblinzitorul de tigri <ce>]]?
 that stole the tamer of lions?
 “What did the policeman think that the fake clown had told him
 that the lion tamer had stolen?”

164 *Analysis of the non-local binding phenomenon*

The same story holds for focus movement in Romanian. Motapanyane (2001) shows that extraction of a focused constituent out of indicative clause headed by the complementizer *că* is possible. Just as is the case with *wh*-movement, focus movement leaves a reflex in the intermediary landing sites. It also triggers subject inversion (compare the position of the embedded clause subject, *Maria*, in (56 a) versus (56 b)).

56. a. Ion MASINA_i spunea c-ar fi vrut-o_i t_i Maria.
Ion car_{DEF} said that would be wanted it Mary
“It was the car John said that Mary would have wanted”.
- b. *Ion MASINA spunea că Maria ar fi vrut-o.
Ion car_{DEF} said that Mary would be wanted it

5.2. Islands

I would like to remind the reader that in Chapter 3, section 5.3, I have introduced the relevant data about non-local binding and island effects. The most important conclusion of that discussion was, in fact, a descriptive generalization about non-local binding and islands, which stated that only those islands that are introduced by quantificational elements are opaque for non-local binding. This generalization divides islands as follows: complex DPs followed by complement clauses and *wh*-islands do not block non-local binding, since they are introduced either by the C *că* (that) or by the *wh*-complementizer *dacă* (if); adjunct islands, relative clauses as well as those *wh*-islands introduced by quantificational *wh*-phrases (such as *cine*, who) block non-local binding (with the proviso that non-local binding into relative clauses seems to be a trifle better than non-local binding into adjunct clauses, though still quite unacceptable).

I suggest that the unacceptability of non-local binding out of the islands that rely on quantificational interveners receives a similar explanation to the one that I have given with respect to *wh*-intervenors and relativized minimality effects (see section 4.2.1 and the explanation of descriptive generalization 1). Basically, the features of the bare reflexives are too deeply embedded under the quantificational introducing element. This would clarify why temporal adjuncts introduced by *cînd* (when) are out. Let us now consider relative clause.

57. [DP RC head_i] [CP Op/which_i [C (+REL) [TP t_{WH}... PP SINE]]]

As shown in (57), the feature of *sine* will be deeply embedded under those of the *wh*-phrase that gets coindexed with the head of the relative.

One question that I have not answered yet concerns those adjunct islands that are not introduced by quantificational *wh*-phrases, but by non-quantificational prepositional complementizers. Even so, such adjunct clauses do not allow for non-local binding into them. I show below that this is the case for adjuncts introduced by *din cauza că* (out of cause that), *pentru că* (because that), *de parcă* (as if).

58. George_i a facut criză de nervi din cauza că/pentru că fiul lui_j a vorbit urât despre sine^{*_{i,j}} la întâlnirea de familie.
George has made crisis of nerves out of cause that son.the his has spoken ill about self at meeting.the of family
“George had an attack of nerves because his son spoke ill of his son / George at the family meeting”.
59. Alex_i a reacționat de parcă George_j ar fi contat prea mult pe sine^{*_{i,j}}.
Alex has reacted as if George had counted_{COND} too much on self
“Alex reacted as if George had counted too much on George/ Alex”.

I suggest that what is at (additionally) stake here is the adjunction site of these adverbial clauses. They are introduced by what might be termed evaluative and evidential elements, which rate very high in the hierarchy of functional adverbial heads from Cinque (1999). This in itself could be source of the ungrammaticality.

I will conclude the island section after I have made two more points. The first, concerns a comparison to Icelandic non-local binding into adjunct clauses. It will become clear immediately why such a comparison is of use. Second, I will make some additional remarks on one of the violable islands, i.e. the complex DP followed by a complement clause.

Icelandic non-local binding is blocked out of strong islands such as the adjunct island (cf. 60 a) and the complex DP followed by a relative clause (cf. 60 b).

166 *Analysis of the non-local binding phenomenon*

60. a. *Jon_i kemur ekki nema Maria elski sig_i.
Jon comes not unless Maria loves_{SSUBJ} himself
“Jon won’t come unless Maria loves him”.
- b. *Olafur_i hefur ekki enn fundið vinnu, sem sér_i líkar.
Olaf has not yet found a.job that self likes
“Olaf has not yet found a job that he likes”.

Quite interestingly, ungrammatical examples such as (60) become perfectly all right once they are further embedded, as shown by (61).

61. a. Jon_i segir að Haraldur komi first Maria byður ser_i.
Jon says that Harald comes_{SSUBJ} since Maria invites_{SSUBJ} himself
“Jon says that Harald will come since Maria has invited him”.
- b. Jon_j segir Olafur_i hefur ekki enn fundið vinnu, sem sér_{i,j} líkar.
Jon says that Olaf has not yet found a.job that self likes
“Jon says that Olaf has not yet found a job that he likes”.

The contrast between (60) and (61) suggests that Icelandic benefits from an island repair strategy for non-local binding into relative clauses and adjunct islands. The repair strategy consists in further embedding under a verb of saying (or under verbs that associate with perspective-holding subjects). Given what we already know about *sig*, namely, that it is a logophor, this fact does not come as a surprise. A logophor is much better once it relates to a perspective holding antecedent. Since I have argued that *sine* is not a logophor, the prediction would be that further embedding as in (62) would not count as a repair strategy. The prediction is indeed borne out.

62. Seful_k a vazut ca Alex_i a reacționat [de parcă George_j ar fi contat prea
Boss.the has seen that Alex has reacted as if George had counted_{COND}
mult pe sine^{*i,j,*k}].
too much on self
“The boss saw that Alex reacted as if George had counted too much on
George/Alex/the boss”.

Let us now turn to the violable islands. Note that, even if the complex DP followed by a complement clause is a strong island, some cases of extraction out of it are quite acceptable in Romanian.

63. Pe care polițist au lansat zvonul că
 Which policeman have.they launched rumor.the that
 l-a mituit primul ministru?
 him_{CL.ACC} has bribed prime.the minister
 “Which policeman did they launch the rumor that the prime minister
 bribed?”

True enough, the complex DP followed by a complement clause remains a strong island and extraction out of is not so easily available. I would like to make a comment about examples in the vein of (63). Three factors need to be controlled for extraction out of a complex DP to work. First, an argument needs to be extracted, not an adjunct. Second, it is better if it that argument is a clitic doubled direct object. Third, it helps if the respective *wh*-argument is D-linked. Note, incidentally, that even non D-linked *wh* subjects could be extracted out of a complex DP if the complement clause has the verb in the subjunctive introduced by a complementizer⁵⁸.

64. Cine ai făcut sugestia ca mâine
 Who have.you made suggestion.the that_{SUBJ COMP} tomorrow
 să se prezinte de urgenta la sef?
 să_{SUBJ} se_{REFL.CL} present of emergency at boss
 “Who did you make the suggestion that should show up by all means
 at the boss?”

It has been argued that subjunctives introduced by complementizer have phase-status (Alboiu 2004a, 2006). So, on this count they do not differ from complement clauses with the verb in the indicative. It is only the nature of complementizers that differs.

I will wrap up this section by simply noting that the way islands interact with non-local binding crucially depends on the nature of the elements that

⁵⁸ See Chapter 2 for a presentation of the types of subjunctive clauses in Romanian.

introduce the respective islands. Those introducing elements with quantificational properties block non-local binding; those without, allow it. The islands that are introduced by non-quantificational evidential and evaluative prepositional complementizers are simply too high in the structure for the T in the matrix clause, with the relevant operator feature for non-local binding, to be able to probe for the bare reflexive.

6. *Conclusions*

This chapter has aimed at further exploring Reuland's (2001, 2005) idea that binding must have a syntactic residue and cannot, therefore, be resolved exclusively at the semantic level.

I have dwelt on non-local binding facts to achieve this goal. I have tried to demonstrate that at least some non-local binding facts lend themselves to an account in terms of an A'-dependency. The main condition for non-local binding to go through is that the T head in both the embedded clause, which contains the anaphor, and the main clause bear a discourse-related operator feature in addition to the usual ϕ set and tense feature. In fact, the T head and, implicitly, its connection to other positions in the left periphery and the C head that selects it, play a crucial role in determining binding possibilities. I have pointed out the way by which the T head gets involved with binding. More precisely, a fully specified T head (with a ϕ set, an operator feature and a tense feature) acts as a Probe that facilitates the anaphor's escape from its merge position and provides thus the first step non-local binding. This is the case of non-local binding out of finite clauses in Romanian. In case the T head is not fully specified, but deficient in the sense of lacking the features to be checked by lexical items that move to the left periphery, non-local binding is precluded. I have also shown that non-local binding entails a split way of feature checking. Feature checking on *sine* is split. This falls in line with Rizzi's (2004) assumption that complex phrases might come to check their features in different sites. *Sine* is not a complex phrase, but it does have compounded features, agreement *and* operator. The agreement features are checked against the embedded tense and the operator feature against the matrix tense.

Concluding Remarks

The recent versions of the Minimalist Program (Chomsky 2001, 2004, 2005) have proposed and stressed the idea that the operations internal to the computational system of the human language proceed in as efficient a way as possible. This implies that any theoretical notion, involved in accounting for how these particular operations proceed, whose existence does not follow from virtual necessity considerations should be discarded. More precisely, theoretical notions such as bar levels, traces of moved elements and indices fall in the category of concepts that create problems for the efficient model of computation. Indices, for instance, are troublesome because they introduce new objects in the derivation and alter thus the syntactic objects that go into the computation. In other words, the presence of indices violates the Inclusiveness Condition, one of the constraints imposed by efficient computation. Note, however, that indices represent a crucial ingredient in the standard formulation of Binding Theory (Chomsky 1981, 1986). Indexing renders identity of reference between an anaphor or a pronoun and their antecedent. Alternatively, conindexing implies that such an identity of reference should not obtain. A binding theory without indices faces first and foremost the task of capturing this identity of reference. However, the indices problem is not the only one that needs solving in the attempt to account for binding in minimalist terms. Apart from the existence of an efficient model of computation, another important tenet of the Minimalist Program is that language represents the best solution to connect sound and meaning (the strong minimalist thesis). Language interfaces with what Chomsky calls the *language-external*, but *organism-internal* sensory – motor and conceptual – intensional systems. The sensory – motor and the conceptual – systems are the only levels of linguistic representation whose existence satisfies virtual necessity constraints, because, on minimal assumptions, the I-language needs to relate to the meaning / thought compartment and to the articulatory – perceptory one. In contrast to the architecture proposed by the Minimalist Program, the Government and Binding framework worked with more levels of linguistic representation: d-structure, s-structure, LF and PF. Binding Theory was supposed to be handled both at the s-structure and the LF levels. Hence, apart from the indices problem for binding theory in the Minimalist Program, there is also the level of representation problem. Where is binding handled, now that s-structure and LF have been discarded?

170 *Concluding remarks*

The task of recasting binding theory in minimalist terms has occupied the research agenda recently. Reuland (2001, 2005 a, b) has given answers to the two problems I have mentioned before. The level of representation problem has found an answer in an economic theory of anaphoric dependency encoding. Depending on the intrinsic properties of anaphors, such as specification for ϕ features and other features such as [\pm reflexive marker] and [\pm R] (see Reuland 2005 a, b), anaphoric forms enter interpretive dependencies in syntax, semantics or in discourse. The first of these three options is the cheapest because it relies on an automatic (blind) checking of features in the syntax, within a precisely defined local domain. The next two are incrementally more costly. I have explained in chapter 3 that locality does not put any constraint on semantic binding. The crucial point for semantic binding is that the right operator – variable configuration is established. The absence of locality constraints makes the semantics option more costly than the syntactic one. As for interpretive dependencies in discourse, they should be the most costly because they do not stem from the set-up of any (structural) configuration. In syntax, the indices problem could be solved if binding gets reduced to the establishment of a Probe – Goal relation between a functional head Probe and the Goal anaphor (a relation implemented by Agree). In other words, binding represents the by-product of feature checking. It is the feature checking procedure that renders the antecedent – anaphor dependency. Indices turn, hence, into disposable items.

Given the economic theory of strategies to encode anaphoric dependencies, the main purpose of the present dissertation has been twofold. First, it has been an attempt to widen the search for phenomena that bear relevance to the idea that binding does have a syntactic residue and is not, therefore, an exclusively semantic matter. Second, it has attempted to provide the technical means to account for these phenomena. In what follows, I will spend more time enlarging on these two issues.

I have used the case of the non-local binding of the Romanian bare reflexive *sine* to back up the view that the syntactic residue of binding extends to include A' dependencies. I have defined non-local binding as a type of binding dependency that violates the Specified Subject Constraint. I also have identified a set of properties that characterizes non-local binding. These properties are: subject orientation, c-command by both the local and the non-local antecedents and the restriction to the bound variable reading.

The diagnostics that point to the conclusion that an A' dependency has been established include (i) ungrammaticality of non-local binding out of adjunct islands and its very marginal acceptability out of relative clause islands and (ii) blocking of non-local binding by *wh*-antecedents and quantified antecedents. The blocking in (ii) subsumes under the label of relativized minimality violations. As far as island sensitivity is concerned, I have noted that non-local binding out of the complex DP followed by a complement clause island and out of *wh*-islands does not yield ungrammatical results, but see (i)). I proposed that the way islands interact with non-local binding crucially depends on the nature of the elements that introduce the respective islands. Those introducing elements with quantificational properties (*wh*-phrases) block non-local binding; those without (the complementizer *ca*, (that), and the *wh*-complementizer *daca* (if) allow it. I formulated three descriptive generalizations about Romanian non-local binding. The first states that Romanian non-local anaphors are sensitive to relativized minimality effects induced by *wh* and quantified antecedents. The second establishes that Romanian non-local binding dependencies start out of embedded finite clauses (subjunctive and indicative clauses). The third states that Romanian non-local binding dependencies are sensitive to the Blocking Effect, as known from East-Asian languages..

The basic assumption about *sine* is that it morphologically decomposes in two parts, *si-ne*. The first part, *si-*, encodes ϕ features (a specification for the third person and one for inherently singular number). The second part, *-ne*, encodes an operator feature. The bi-morphemicity of *sine* dictates its behavior. In other words, it determines that *sine* can be both locally licensed, in terms of ϕ features, and non-locally licensed, as a result of checking of the operator feature.

Once the bi-morphemic make-up of *sine* laid out, the descriptive generalizations I have mentioned above can be straightforwardly derived. The first one follows from the fact that, due to its morphologically encoded operator feature, the bare reflexive has similar featural make-up with the intervening *wh* and quantified antecedents. The second follows from the fact that only finite Ts have a fully-developed left-periphery, which can license *wh*-phrases (among other phrases, such as focalized ones). This entails that only finite Ts hosts the relevant operator feature that is necessary for *wh*-movement licensing. I have suggested that non-local binding needs the same type of operator feature to license it. If the relevant operator feature is not there on T, the only the local reading follows and the unvalued operator part of the bare reflexive takes on a

172 *Concluding remarks*

default value. The third generalization follows from the fact that, as the initial part of the operation of Agree, the computational system blindly performs a purely formal feature check in those configurations that qualify as *checking configurations* in the sense of Chomsky 1995. When the features of *sine* raise to the intermediate T, they are precisely in such a checking configuration. The check yields a mismatch, and the Blocking Effect follows. I have proposed that the Blocking Effect could be understood as a test for the intermediary landing site that the features of *sine* “transits”. It is generally accepted that *wh*-movement makes use of the same kind of intermediary landing sites. For Romanian, subject inversion (i.e. the fact that the subject is confined to its in situ position) that necessarily accompanies *wh*-movement marks intermediary sites. My suggestion is that sensitivity to the Blocking Effect does the same job for intermediary sites with non-local binding dependencies.

Finally, I would also like to remark that the type of non-local binding I have analyzed here does not instantiate a singular case of a dependency that starts out of a finite clause. Rogers (1971, 1972, 1974 a), Potsdam & Runner (2001), a.o. discuss a type of construction that Rogers has initially dubbed “Richard”. This construction, also known as Copy Raising, is illustrated below.

1. a. It seems like Richard is in trouble.
b. Richard seems like he is in trouble.
c. Richard seems to be in trouble.

The important parts are (1a) and (1b). In (1 b) the raising verb *seem* has a subject and the verb in the embedded clause also has a pronoun subject, which is interpreted only as a bound variable. This particular situation does not square with the current assumptions about standard raising structures, like the one illustrated in (1 c).

Romanian seems to have something quite similar to (1b). The only difference is that the subject in the embedded clause is a *pro* rather than an lexically realized pronoun⁵⁹.

⁵⁹ Grosu & Horvath (1984) note that even raising out of complementizer subjunctives might be possible in Romanian. They mention these cases are subject to idiolectal variation, but I happen to be a native speaker who finds such sentences acceptable. I give

2. George pare ca a inteles problema.
George seems that has understood.the problem.the
“George seems that he understood the problem”.

The question about the way to explain the dependency in (1 b), by movement or by representational chain formation, remains open to debate. The point that I want to make is that both Copy Raising and non-local binding represent ways of having dependencies out of finite clauses. Moreover, in both cases the dependent element, the subject in Copy Raising and the non-local anaphor, are restricted to the bound variable interpretation. It remains an open research topic whether a detailed account of these particular dependencies into finite clauses could be argued to share something.

below their example. For a recent minimalist analysis of raising out of subjunctive complements, see Rivero & Geber to appear.

- (1) Băieții s-au nimerit ca toți trei să plece la mare in aceeași zi.
The boys REFL HAVE.PRES.3.PL happened that all three SUBJ leave at sea in same day
“The boys happened to leave all three for the seaside on the same day”.

Appendix

A Magnitude Estimation experiment on non-local binding

1. *Introduction. The method.*

As already mentioned in Chapter 1, section 2.2.1, not all native speakers of Romanian accept the sentences with non-local binding. In short, non-local binding gives rise to idiolectal variation among speakers.

To check the availability of non-local binding in a thorough and systematic way, I have conducted a magnitude estimation experiment (Sorace 2003, Sorace and Keller 2005, a.o). I have chosen this particular experimental method because it has been especially devised so as to provide a way to measure gradience in grammaticality judgments. An experimental method whose goal is to elicit judgments of linguistic acceptability in terms of scales such as *acceptable* versus *unacceptable* or *acceptable*, *?*, ***, **** could not be employed to test the idiolectal variation on non-local binding because it makes use of too a restricted range of values and it consequently cannot capture in a systematic way the different acceptability judgments native speakers have.

I have tested a total of 18 subjects, whose average age is 20 years old, who were asked to rate the acceptability of 36 complex sentences (matrix and embedded clause) in relation to one reference sentence. The 36 complex sentences were split in two groups: 18 complex sentences that involve binding and other 18 filler complex sentences. The sentences listed in the questionnaire are organized as follows: the first six, (1-6), contain only instances of non-local binding. I have constructed them in such a way that the local subject (of the embedded clause) does not provide an antecedent for the non-local anaphor because (i) it is inanimate, see sentences (1) – (2) in the questionnaire or (ii) it is a collective noun, see sentences (3) – (6). The next six sentences, (7-12), involve only local binding. Finally, the next six, (13-18), feature contexts in which the Blocking Effect applies. Sentences (19-36) are the fillers. The experiment has been given out in four different versions of randomized sentences. The main prediction was that (i) the local binding sentences will be considered perfectly acceptable by all native speakers, (ii) the Blocking Effect sentences will be ungrammatical – straightforwardly for those speakers who do not allow non-local binding, and also for the speakers who allow non-local binding because

176 *Appendix*

they will detect a blocking effect, and (iii) the non-local binding sentences will show a split in terms of linguistic acceptability between the two groups of native speakers. More precisely, they were expected to be more acceptable than the Blocking effect sentences, but less acceptable than the local binding ones. Section 2 of the Appendix includes the questionnaire. Section 3 has the results.

2. *The questionnaire*

Sex: male female

Age: 15 – 25 25 – 35 35 – 45 45 – 55 55 – 65

Birthplace:

Do you consider yourself as a speaker of a certain dialect?

Education:

Linguistics background: yes no

If you want to get the results of the experiment, you can leave your email address.

You will go through a preparatory session before you start the experiment itself. You will see on the screen a couple of lines whose length you will have to estimate in comparison to a reference line that will be shown to you in the beginning. For instance, let us say that the following reference line is 1 cm long:

—

You will see below a couple of other lines whose length varies as compared to the reference line:

—

If you believe that the second line is ten times longer than the reference line, give it a 10. If the third line is twenty times longer than the reference line, give it a 20. If the fourth one is half the length of the reference line, give it a 0,5 and so on and so forth.

- Use the instructions above the estimate the lengths of the following lines (write the numbers on the right side of the sheet of paper):

Instructions

This is an exercise that does not call for you to put into practice the knowledge of Romanian grammar that you have acquired in school/high-school/university. What I would like to test with the help of your intuitions of native speakers of Romanian is the acceptability of the sentences included in the experiment. Generally, we believe that a sentence has a high degree of acceptability because it is something that someone would naturally say in a conversation (for instance, *Cartman knows that Kenny's parents are as poor as church mice*). There are, however, cases when the degree of acceptability decreases because the sentence is too complex or it is something that someone would not normally say (for instance, *For whom does Kenny ask himself whether Cartman wrote the threatening letters?*).

To sum up, the main requirement of the experiment is for you to mark the acceptability of each sentence by assigning it a number as compared to a reference sentence that you can see at the beginning of each section. For instance, let us say that the following sentence is your reference sentence and you give it a 1 because it is unacceptable:

1. Am omul vazut.
Have.I man.the seen
"I have seen the man".

Next, you will see the following sentences:

2. Politisti am cunoscut buni.
Policemen_{MASC.PL} have.I known good_{MASC.PL}
3. Am cunoscut politisti buni.
Have.I known policemen_{MASC.PL} good_{MASC.PL}

178 Appendix

4. Am vazutul om.
Have.I seen.the man

If you have given a 1 to the reference sentence and you think the second sentence is ten times better than the reference, give it a 10. If the third sentence is twenty times better than the reference, give it a 20. If the fourth sentence is half as good as the reference, give it a 0,5 and so on and so forth.

In addition to full numbers, you are allowed to use decimals and fractions. Only minus numbers are not accepted.

Important points to remember:

- Use any range of positive numbers
- Evaluate each complex sentence by comparing it to the reference sentence that you can find at the beginning of each section. Use any number you want for the first sentence
- Do not think too much before you assign a number to a sentence and do not go back to the already marked sentences in order to change the number that you have initially assigned to it;
- (Optional) If you think there is speaker variation with regard to the acceptability of a certain sentence, explain briefly why you think this variation exists;
- Do not forget that this is not a test with correct or incorrect answers.

Reference sentence

*Cine a spus George ca are t <CINE> incredere in sine?
"Who did George say that (he) has trust in self?"*

1. Maria n-a dat niciodata atentie la ce discuta lumea pe la spatele ei. Ea a fost mereu constienta ca birfele nu conteaza pentru sine.
"Mary has never paid attention to what people say behind her back. She has always known that gossips do not count for self".
2. Paul e o celebritate urmarita peste tot de jurnalisti. El e constient ca ziarele scriu multe despre sine.
"Paul is a celebrity that the journalists follow everywhere. He is quite aware that there is a lot about self in the newspapers".
3. Stefan le povesteste tuturor ca pe el nu-l sperie nimeni si nimic. Isi doreste ca toti cunoscutii sa vada in sine un erou neinfricat.

- “Stefan tells everybody that nobody and nothing scare him. He wishes that all this acquaintances see a fearless hero in self”.
4. Dana a trecut printr-o faza paranoica la petrecerea de aseara. A reactionat ca si cind lumea ar fi ris pe ascuns de sine si ar fi birfit-o tuturor prietenilor.
“Dana went through a paranoic episode at the party last night. She reacted as if people had laughed secretly at self and had gossiped about her to all her friends”.
 5. Alex a inteles in cele din urma ce a stat la baza reusitelor lui. Si-a dat seama ca o parte din companie a crezut mereu in sine si de aceea a avut el succes intotdeauna.
“Alex finally understood what lies at the foundation of his success. He realized that part of the company had always believed in self and that was why he head always been successful”.
 6. Ioana e satisfacuta de ce reuseste sa faca. Ea nu intelege pentru ce familia ei e mereu nemultumita de sine.
“Ioana is satisfied with what she manages to do. She does not understand why her family is always discontent with self”.
 7. Baiatul asta se gindeste numai la altii. El uita de sine mereu.
“This boy only thinks about other people. He always forgets about self”.
 8. Mihai are mult umor. Ride de sine ori de cite ori are ocazia.
“Mihai has a lot of humor. He laughs at self whenever he has the chance”.
 9. Prietena lui n-are nici o problema existentiala. Ea a crezut intotdeauna in sine.
“His girlfriend has no problem in life. She has always believed in self”.
 10. Spionul lor e total timpit. Ieri a dezvaluit noi secrete despre sine.
“Their spy is a total fool. Yesterday he revealed new secrets about self”.
 11. In discursul de ieri seful s-a umflat in pene. A amintit tot timpul de sine si succesele lui.
“The boss blew his whistle at yesterday’s speech. He kept reminding about self and his success”.
 12. George este inconstient. Pentru o mica suma de bani ar testa orice medicament nou pe sine.
“George is crazy. For a small amount of money he would test on himself any new medicine”.

180 *Appendix*

13. Am discutat cu Ana despre cei care au sprijinit-o intotdeauna. A recunoscut ca eu am crezut mereu in sine.
"I talked with Anna about those who had always supported her. She admitted that I had always believed in self".
14. Fiecare a trebuit sa spuna doua vorbe despre Andrei. El a insistat ca si tu sa comentezi ceva despre sine.
"Each (of them) had to say a couple of words about Andrei. He insisted that you comment something about self too".
15. Regele nu are nici o indoiala in legatura cu loialitatea ta. Stie ca tu ai contat pe sine in orice situatie.
"The king has no doubt about your loyalty. He knows that you have counted on self in any situation".
16. Ziaristul banuieste ca unii dintre colegii lui se considera mai buni ca el. Crede ca ei il compara cu sine.
"The journalist suspects that some of his colleagues think they are better than him. He thinks they compare him with self".
(The intended meaning: They compare him to themselves).
17. Presedintele are numai intentii bune. Isi doreste ca toti consilierii sa fie multumiti de sine.
"The president has only good intentions. He wishes that all this counsellors be satisfied with self".
18. Andreea a avut o relevatie in legatura cu prietenii ei apropiati. A priceput in cele din urma ca ei au descoperit lucruri nebanuite in sine.
"Andreea had a revelation with regard to her close friends. She finally understood that they had discovered unexpected things in self".
19. Mi-am imaginat ce a spus George ca a cumparat Alex - ultima carte a lui Chomsky.
"I guessed what George said that Alex bought - Chomsky's latest book".
20. Spectorii au vazut pe cine a inteles spionul ca a sarutat presedintele. Pe Monica Lewinski.
"The audience saw who the spy understood that the president had kissed - M. Lewinski".
21. Lumea se intreba ce ai crezut ca a impuscat vinatorul - un urs urias.
"People ask themselves what you believed that the hunter shot - A huge bear".

22. Petre a vrut sa stie ce ai auzit ca a dat judecatorul - verdictul in cazul Jackson.
"Peter wanted to know what you heard that the judge passed - the sentence on the Jackson case".
23. Cred ca poti sa-mi spui la cine ai inteles ca a apelat el. - la soacra lui, bineinteles.
"I think you can tell me who you understood he resorted to - To his mother-in-law, of course".
24. Martorii au auzit ce a negat politistul ca a cerut - mita de la inculpat.
"The witnesses heard what the policeman denied that he had asked - bribe from the defendant".
25. Eu am intrebat ce e a sustinut politistul ipoteza ca a furat inculpatul - un aparat de aer conditionat.
"I asked what the policeman put forth the hypothesis that the defendant had stolen - an air-conditioning unit".
26. Procurorul vrea sa stie cui apreciaza Dan faptul ca i-a dat ministrul un sfat - nepotului Mariei.
"The prosecutor wants to know to whom Dan appreciates the fact that the minister had given some advice - to Mary's nephew".
27. Ziaristul cerceteaza pe cine a raspindit Adrian zvonul ca va aresta politistul. Pe Ion Iliescu.
"The journalist investigates who Adrian spread the rumor that the policeman will arrest - Ion Iliescu".
28. A aflat in sfirsit ce a respins Alexandru ideea ca va construi primaria. Un monument urit in centrul orasului.
"He finally found out what Alexandru rejected the idea that the mayor would build - an ugly monument in the city center".
29. Petre se intreba la cine l-a ingrozit pe om perspectiva ca va apela nevasta lui - la amantul ei.
"Peter wonders to whom the man was terrified at the perspective that his wife would resort - to her lover".
30. Colegii s-au interesat pe cine a deranjat aluzia ca il va concedia seful - pe functionarul lenes.
"The colleagues wonder whom was disturbed by the hint that the boss will sack - the lazy clerk".

182 *Appendix*

31. Am ghicit pe care dintre soldati te intrebi cine i-a interogat - pe soldatii din regimentul 1.
"I guessed which of the soldiers you wondered who had interrogated - the soldiers from the first regiment".
32. Am verificat la care intrebare te-ai interesat ce a raspuns - a raspuns la intrebarea Ioanei.
"I checked to what question you inquired what he answered - he answered to Ioana's question".
33. Am aflat pe care angajat iti amintesti cine l-a distrus - l-a distrus pe cel mai guraliv.
"I found out which employee you remembered who had destroyed - he destroyed the most talkative".
34. Toti vroiau sa stie pe care baiat ai auzit ce l-a intrebat - l-a intrebat pe Catalin.
"Everybody wanted to know which boy you heard what he asked - he asked Catalin (a question)".
35. Cercetatorul a notat la care stimul ai aflat cine a reactionat - A reactionat la stimulul luminos.
"The researcher wrote down which stimulus you found out who had reacted to - he reacted to the luminous stimulus".
36. Pe care spion te preocupa cine l-a tradat - pe spionul rus.
"I am curious which spy you worry over who has betrayed - the Russian spy".

3. *Results and their interpretation*

A repeated measures ANOVA on the average natural logarithmic estimations did not indicate a significant overall effect of sentence type (local, LD, blocking): $F_1(1,098, 18,666) = 1,288, p = 0.289^{60}$ (see Figure 1 below).

For the item analysis, each sentence was averaged over subjects. A one-way ANOVA on the average natural logarithmic estimations indicated a significant overall effect of item type (local, LD, blocking): $F_2(2,17) = 10,098, p = 0.002$

⁶⁰ Since Mauchly's test of sphericity was significant, the Greenhouse-Geisser corrected F value is reported.

The post-hoc tests revealed no significant difference between local and LD ($p=0.209$), but there was significant difference between local and blocking ($p=0.001$), and long distance and blocking ($p=0.043$) (see Figure 2 below).

In plain terms, these results point to two conclusions. The first is that, in the subject analysis, there was no significant difference in acceptability between the long distance and local binding sentences, on the one hand, and the blocking sentences, on the other. This entails that an analysis over subjects cannot cast any light on whether the long distance sentences are linguistically acceptable or unacceptable. However, the item analysis (i.e. the mean for the responses to each sentence averaged over subjects), did show a difference between sentence types, i.e long distance and local binding sentences on the one hand and blocking sentences on the other. The former group was judged acceptable, the latter, unacceptable.

Estimated Marginal Means of In estimations: Subject analysis

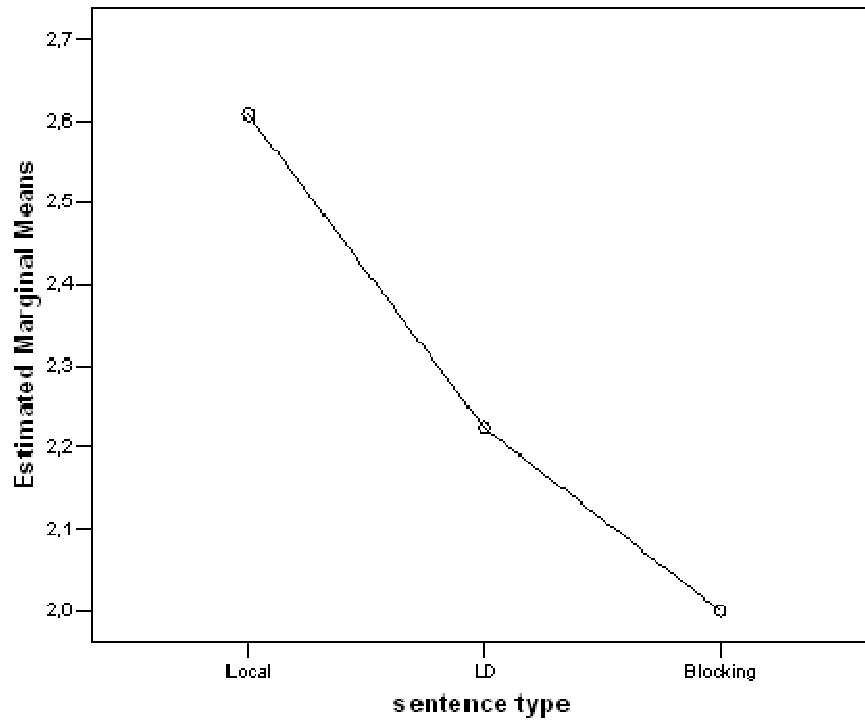
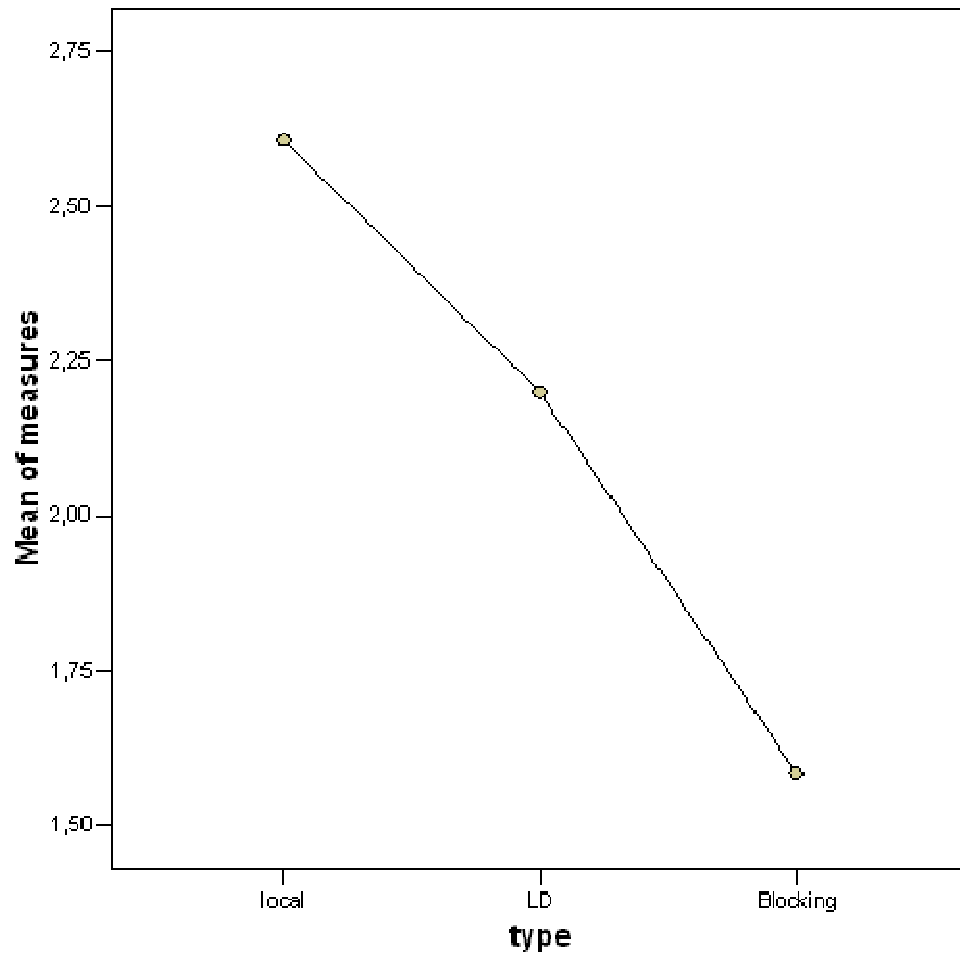

Figure 2



REFERENCES

- Alboiu, G. 2002. *The Features of Movement in Romanian*. Bucharest: Editura Universitatii Bucuresti.
- Alboiu, G. 2004 a. Shared arguments in control. *Toronto Working Papers in Linguistics* 22, 53-74, University of Toronto Press.
- Alboiu, G. 2006. Are we in agreement? In *Agreement Systems*, C. Boeckx (ed.), 13-39, John Benjamins.
- Alexiadou, A. and Anagnostopoulou, E. 1998. Parameterizing AGR: word order, V-movement and EPP-checking. *Natural Language and Linguistic Theory* 16, 491-539.
- Anagnostopoulou, E. and Everaert, M. 1999. Toward a more complex typology of anaphoric expressions. *Linguistic Inquiry* 30, 97-118.
- Anand, P. and Nevins, A. 2004. Shifty operators in changing contexts. *Proceedings of SALT XIV* R.B. Young (ed.), Ithaca: CLC Publications.
- Barbosa, P. 1994. *Null arguments*. Ph.D. Thesis, MIT.
- Bard, E.G., Robertson, D., Sorace, A. 1996. Magnitude estimation of linguistic acceptability. *Language* 72, 1, 32-68.
- Chierchia, G. 1989. Anaphora and attitudes *de se*. In R. Bartsch, J. van Benthem and P. van Emde Boas (eds), *Semantics and Contextual Expression*, 1-31, Dordrecht: Foris.
- Chomsky, N. 1973. Conditions on transformations. In S.R. Anderson and P. Kiparsky (eds) *A Festschrift for Morris Halle*, New York: Holt, Rinehart & Winston.
- Chomsky, N. 1981. *Lectures on Government and Binding*. Dordrecht: Foris.
- Chomsky, N. 1986. *Knowledge of Language: Its Nature, Origin and Use*. New York: Praeger.
- Chomsky, N. 1995. *The Minimalist Program*. MIT Press, Cambridge, MA.
- Chomsky, N. 2000. Minimalist inquiries: The Framework. In: R. Martin et al (eds.), *Step by Step: Essays on Minimalist Syntax in Honor of Howard Lasnik*. Cambridge, Mass: MIT Press, 89-157.
- Chomsky, N. 2001. Derivation by phase. In: M. Kenstowicz (ed.), *Ken Hale: A Life in Language*. Cambridge, Mass: MIT Press, 1-53.
- Chomsky, N. 2004. Beyond Explanatory Adequacy. Structures and beyond. *The Cartography of Syntactic Structures*, volume 3. A. Belletti (ed.), 104 -131. Oxford: Oxford University Press.
- Chomsky, N. 2005. On phases, *ms*. MIT.
- Chomsky, N. 2005. Three factors in language design. *Linguistic Inquiry* 36, 1-22.

188 *References*

- Clements, G.N. 1975. The logophoric pronoun in Ewe: Its role in discourse. *Journal of West African Languages* 10, 141-177.
- Cole, P. and Sung, L.-M. 1990. Principles and parameters of long distance reflexives. *Linguistic Inquiry* 21, 1 – 22.
- Cole, P. and Sung, L.-M. 1994. Head movement and long distance reflexives. *Linguistic Inquiry* 25, 355 – 406.
- Cole, P. et al 2001b. Logophoric conditions on long distance reflexives in two Chinese dialects. In: *Long Distance Reflexives* P. Cole, G. Hermon and C-T.J. Huang (eds.), *Syntax and Semantics: Long Distance Reflexives* 33, New York: Academic Press.
- Comorovski, I. 1986. Multiple Wh-Movement in Romanian. *Linguistic Inquiry* 17.1, 171-177.
- Comorovski, I. 1996. *Interrogative Phrases and the Syntax – Semantics Interface*. Dordrecht: Kluwer Academic Publishers.
- Cornilescu, A. 1997. Some notes on the syntax of the subject. In *Revue Roumaine de Linguistique* XLII, 101-147, Bucharest, Editura Academiei Române.
- Cornilescu, A. 2002 a. At the Romanian left periphery. *Bucharest Working Papers in Linguistics* 4, 89-108, Polirom.
- Cornilescu, A. 2002 b. The Double subject construction in Romanina. In V. Motapanyane (ed.) *Comparative Studies in Romanian Syntax*, 83-133.
- Dimitriadis, A. and Everaert, M. 2004. Typological perspectives on anaphora. In B. Comrie, P. Suihkonen and V. Kelmakov (eds.), *Proceedings on the international symposium on deictic systems and quantification in languages spoken in Europe and North and Central Asia*, The Udmurt State Univesity.
- Dobrovie – Sorin, C. 1994. *The Syntax of Romanian*. Berlin: Mouton de Gruyter.
- Enç, M. 1989. Pronouns, licensing and binding. *Natural Language and Linguistic Theory* 7, 51-92.
- Everaert, M. 1986. *The Syntax of Reflexivization*. Dordrecht: Foris.
- Evans, G. 1980. Pronouns, *Linguistic Inquiry* 11, 337-362.
- Giorgi, A. 1984. Toward a theory of long distance anaphors: a GB approach. *The Linguistic Review* 3, 307-361.
- Giorgi, A. 2004. Long distance anaphors and temporal relations. In: G. Garding and M. Tsujimura (eds.), *WCCFL 23 Proceedings*. Sommerville, MA: Cascadilla Press.
- Grillo, N. 2005. Minimality effects in agrammatic comprehension. In S., Blaho, L., Vicente, E., Schoorlemmer (eds), *Proceedings of ConSOLE XIII*, 107-120.
- Grodzinsky, Y. and Reinhart, T. 1993. The Innateness of binding and coreference. *Linguistic Inquiry* 24, 1, 69-101.

- Grosu, A and Horvath, J. 1984. The GB theory and Raising in Romanian. *Linguistic Inquiry* 15, 2, 348-353.
- Gyuris, B. 2002. *The Semantics of Contrastive Topics in Hungarian*, unpublished doctoral thesis.
- Hagège, C. 1974. Les pronoms logophoriques. *Bulletin de la Société de Linguistique de Paris* 69, 287-310.
- Hellan, L. 1980. Anaphora in Norwegian and the theory of grammar. In Kreiman, J. and A., Ojeda., (eds.), *Papers from the parasession on Pronouns and Anaphora*, CLS 1980, 166-182.
- Hellan 1991. Containment and connectedness anaphors. In *Long-Distance Anaphora* J. Koster and E.J.Reuland, (eds.), 27-48. Cambridge: Cambridge University Press.
- Hill, V. 2002. Adhering focus. *Linguistic Inquiry* 33 ,1, 164-172.
- Huang, C.-T.J., and Tang, C.-C.J, 1991. The local nature of the long distance reflexive in Chinese. In *Long-Distance Anaphora* J. Koster and E.J.Reuland, (eds.), 263 -283. Cambridge: Cambridge University Press.
- Huang, C.-T., J. and Liu, C.-S. 2001. Logophoricity, attitudes and *ziji* at the interface. In P. Cole, G. Hermon and C.-T., J. Huang (eds.), *Syntax and Semantics: Long Distance Reflexives* 33, 141-197, New York , Academic Press.
- Jackendoff, R. 1992. Mme. Tussaud meets the Binding Theory. *Natural Language and Linguistic Theory* 10, 1, 1-31.
- de Jong, Jelly, J. 1996. *The Case of Bound Pronouns in Peripheral Romance*. Ph.D dissertation. Groningen University.
- Katada, F. 1991. The LF representation of anaphors. *Linguistic Inquiry* 22, 287-313.
- Kayne, R. 2000. Person morphemes and reflexives in Italian, French and related languages. In *Parameters and Universals*. Oxford University Press.
- Koopman, H. and Sportiche, D. 1989. Pronouns, logical variables and logophoricity in Abe. *Linguistic Inquiry* 20, 555-589.
- Koster, J. 1985. Reflexives in Dutch, in J. Gueron and J. Y. Pollock (eds.), *Grammatical Representation*, Dordrecht: Foris Publications.
- Kratzer, A. 2006. Miminal Pronouns, ms. Semanticsarchive.net.
- Kuno, S. 1987. *Functional Syntax*, Chicago: University of Chicago Press.
- Lakoff, G. 1968. *Pronouns and reference*, Bloomington: Linguistics Club, Indiana University .
- Larson, R. and Lujan, M. 1990. Focused Pronouns, paper delivered at University of Maryland, College Park, <http://semlab5.sbs.sunysb.edu/~rlarson/emphpro.pdf>.
- Lees, R. and E. Klima 1963. Rules for English Pronominalization. *Language* 39, 17-28.

190 References

- Maling, J. 1982. Non-clause bounded reflexives in Icelandic. In T. Fretheim and L. Hellan (eds.), *Papers from the Sixth Scandinavian Conference on Linguistics*, 90-106.
- Manzini, M.R. and Wexler, K. 1987. Parameters, Binding Theory and Learnability *Linguistic Inquiry* 18, 3, 413-444.
- Mc Closkey, J. 1990. Resumptive pronouns, A'-binding and levels of representation in Irish. In *Syntax of the Modern Celtic Languages*, R. Hendrick (ed.), volume 23 of *Syntax and Semantics*, 199-248. New York and San Diego, Academic Press.
- Mc Closkey, J. 2005. Resumptive pronouns, M. Everaert, H. van Riemsdijk (eds.) *The Blackwell Companion to Syntax*, Oxford: Blackwell.
- Motapanyane, V. 1995. *Theoretical Implications of Complementation in Romanian*, Unipress.
- Motapanyane, V. 2001. Evidence for focus features. In G.M. Alexandrova, O. Arnaudova (eds.), *The Minimalist Parameter. Selected Papers from the Open Linguistics Forum. Ottawa 213-23 March 1997*, 249-260. Amsterdam: John Benjamins.
- Napoli, D., J. 1976. Reflexivization across clause boundaries in Italian. *Journal of Linguistics* 15, 1-27.
- Pan, H. 2001. Why the Blocking Effect? In: *Long Distance Reflexives* P. Cole, G. Hermon and C-T.J. Huang (eds.), *Syntax and Semantics: Long Distance Reflexives* 33, New York: Academic Press.
- Pesetsky, D. and Torrego, E. 2004. The syntax of valuation and the interpretability of features. To appear in *Clever and Right: A Festschrift for Joe Emonds*, S. Karimi, V. Samiian and W. Wilkins (eds.)
- Philippide, A. 1894. *Istoria limbii romane, volumul I: Principii de istoria limbii*, Iași.
- Pica, P. 1984. On the distinction between argumental and non-argumental anaphors. In W. de Geest and Y. Putseys (eds.), *Sentential Complementation* 185-194, Dordrecht: Foris.
- Pica, P. 1991. On the interaction between antecedent government and binding: The case of long distance reflexivization. In *Long-Distance Anaphora*, J. Koster and E. Reuland (eds.), 119-137, Cambridge: Cambridge University Press.
- Pollard, C. and Sag, I. 1992 Anaphors in English and the scope of Binding Theory. *Linguistic Inquiry* 23, 261-303.
- Postal, P. 1971. *Cross- Over Phenomena*. New York: Holt, Rinehart and Winston.
- Potsdam, E. and Runner, J. 2001. Richard returns: Copy Raising and its implications. In *CLS 37: Proceedings of the Thirty Seventh regional meeting of the Chicago Linguistic Society*, M. Andronis, C. Ball, H. Elston and S. Neuvel, 453-468. Chicago, Illinois, Chicago Linguistic Society.
- Reinhart, T. 1983. *Anaphora and Semantic Interpretation*. London & Sydney: Croom Helm.

- Reinhart, T. 2000. Strategies of anaphora resolution. In *Interface Strategies*, H. Bennis, M. Everaert and E. Reuland (eds.), 295-325. Amsterdam: Royal Academy of Arts and Sciences.
- Reinhart, T. 2002. The Theta System – an Overview. In W. Sternfeld (ed.) *Theoretical Linguistics* 28, 229-290 Berlin: Mouton.
- Reinhart, T. and Reuland, E.J. 1991. Anaphors and logophors: an argument structure perspective. In *Long-Distance Anaphora* J. Koster and E.J.Reuland, (eds.), 283 -321. Cambridge: Cambridge University Press.
- Reinhart, T. and Reuland, E.J. 1993. Reflexivity. *Linguistic Inquiry* 24, 657-720.
- Reinhart, T. and Reuland, E.J. 1995. Pronouns, anaphors and case. In *Studies in Comparative Germanic Syntax*, H. Haider, S. Olsen, S. Vikner (eds.), 241-269, Dordrecht: Kluwer.
- Reuland, E.J. and Sigurjonsdottir, S. 1997. Long distance “binding” in Icelandic: syntax or discourse? In: H. Bennis, P. Pica and J. Rooryck (eds.), *Atomism in Binding*. Dordrecht: Foris, 323 –340.
- Reinhart, T and Siloni, T. 2003. Thematic arity operations and parametric variations. Ms. University of Tel Aviv.
- Reinhart, T. and Siloni, T. 2005. The Lexicon-Syntax Parameter: Reflexivization and other arity operations. *Linguistic Inquiry* 36, 389-437.
- Reuland, E.J. 2001. Primitives of binding. *Linguistic Inquiry* 32, 439-492.
- Reuland, E.J. 2005a .Agreeing to Bind. In N. Corver, H. Broekhuis, R. Huybregts, U. Kleinhenz and J. Koster (eds.), *Organizing Grammar. Linguistic Studies in Honor of Henk van Riemsdijk*. Berlin/New York, Mouton de Gruyter: SSG 86.
- Reuland, E.J. 2005b. Anaphoric dependencies. How are they encoded? Towards a derivation-based typology. Ms. Utrecht Institute of Linguistics, OTS.
- Reuland, E.J. (in press). Gradedness: interpretive dependencies and beyond. In Gisbert Fanselow, et al. eds, *Gradience in Grammar*. Oxford University Press.
- Rezac, M. 2004. Agree and Merge. Ms. on LingBuzz.
- Rezac, M. 2002. Accusative Constructions and the George-Kornfilt Hypothesis. Ms, minimalism.linguistics.arizona.edu/AMSA/PDF/AMSA-201-0602.pdf
- Richards, N. 1997. What moves where and when and in which language? MIT dissertation.
- Rivero, M.L. 1994. Clause structure and V-Movement in the languages of the Balkans. *Natural Language and Linguistic Theory* 12, 1, 63-120.
- Rivero, M. L., Geber, D. to appear. Experiencer Islands and Raising in Romanian.

192 References

- Rizzi, L. 1997. The fine structure of the left periphery. In L. Haegeman (ed.) *Elements of Grammar*, 281-338. Dordrecht, Netherlands: Kluwer Academic Publishers.
- Rizzi, L. 2004. "Locality and Left Periphery". *Structures and Beyond. The Cartography of Syntactic Structures*, ed. Adriana Belletti, 223-252. Oxford University Press.
- Rizzi, L. and U. Shlonsky 2005. Strategies of subject extraction. Ms. University of Siena.
- Rogers, A. 1971. Three kinds of physical perception verbs. *Papers from the Seventh Regional Meeting of the Chicago Linguistic Society* 206-222, Chicago: CLS.
- Rogers 1974a. A transderivational constraint on Richard? *Papers from the Tenth Regional Meeting of the Chicago Linguistic Society* 551-558, Chicago: CLS.
- Rosseti, A. 1938. *Istoria limbii romane*, volumul 1, București.
- Rullmann, H. 2001. First and second person pronouns as bound variables. *Linguistic Inquiry* 35, 159-168.
- Schladt, M. 2000. The typology and grammaticalization of reflexives. In *Reflexives: Forms and Functions*, Z. Frajzyngier and T. Curl (eds.), 103-124, Amsterdam: John Benjamins.
- Sells, P. 1987. Aspects of logophoricity, *Linguistic Inquiry* 18, 445 – 479.
- Schlenker 2003a. A plea for monsters. *Linguistics and Philosophy* 26, 29-120.
- Shlonsky, U. 2004. Enclisis and Proclisis. In *The Cartography of Syntactic Structures*, volume 2, L. Rizzi (ed.), 329-53, Oxford: Oxford University Press.
- Sorace, A. and Keller, F. 2005. Gradiance in linguistic data. *Lingua* 115, 11, 1497-1524.
- Sorace, A. 2003. Magnitude estimation of linguistic acceptability: applications to research on developing grammars. EMLAR presentation, UiL OTS.
- Starke, M. 2001. Move Dissolves into Merge: A Theory of Locality. Ph.D dissertation. University of Geneva.
- Starke, M. 1995. On the format for small clauses. In A., Cardinaletti, T., Guasti (eds.), 237-269, New York: Academic Press
- Thráinsson, H. 1976. Reflexives and subjunctives in Icelandic. In *Proceedings of NELS 6*, 225 – 239. GLSA, University of Massachusetts at Amherst, Amherst.
- Thráinsson, H. 1991. Long distance reflexives and the typology of NPs. In *Long-Distance Anaphora* J. Koster and E.J.Reuland, (eds.), 49 -75. Cambridge: Cambridge University Press.
- Vallduvi, E. 1997. Information Packaging in English and Catalan *Proceedings of the 20th International AEDEAN conference* P., Guardia, J., Stone (eds.), Barcelona, Spain, University of Barcelona.
- Varlokosta, S. and Hornstein, N. 1993. A bound pronoun in Modern Greek, *Natural Language and Linguistic Theory* 11, 175-195.

- Xue, P., Pollard, C. and Sag, I. 1994. A new perspective on Chinese *ziji*. In *Proceedings of the 13th West Coast Conference on Formal Linguistics*, 432-447. The University of Chicago Press and CSLI Publications.
- Winter, Y. 2002. Atoms and sets: A characterization of semantic number. *Linguistic Inquiry* 33, 493-505.
- Zribi-Hertz, A. 1989. Anaphor binding and narrative point of view: English reflexive pronouns in sentence and discourse. *Language* 65, 695-727.
- Zribi-Hertz, A. 1995. Emphatic or reflexive? *Journal of Linguistics* 31, 333-374.

Samenvatting in het Nederlands

Het doel van deze dissertatie is tweeledig. Ten eerste is er een poging gedaan verschijnselen te vinden die betrekking hebben op het idee dat binding een weerslag heeft in de syntaxis, en dus niet enkel een semantische notie is (Reuland 2001, 2005 a, to appear). Ten tweede is getracht een formele methode te vinden om deze verschijnselen te verklaren. In deze samenvatting zal ik deze twee belangrijke onderwerpen behandelen.

Ik heb het verschijnsel van de niet-lokale binding van de Roemeense kale reflexief *sine* (zelf) gebruikt om het standpunt te verdedigen dat de syntactische weerslag van binding ook betrekking heeft op A'-relaties. Niet-lokale binding heb ik gedefiniëerd als een bindingsrelatie die de *Specified Subject Constraint* schendt. Tevens heb ik een aantal eigenschappen geïdentificeerd die kenmerkend zijn voor niet-lokale binding. Deze eigenschappen zijn: oriëntatie op het subject antecedent, het c-commanderen door zowel de lokale als de non-lokale antecedenten en het feit dat alleen de gebonden variabele interpretatie is toegestaan. De volgende argumenten ondersteunen de conclusie dat er sprake is van een A'-relatie: (i) de ongrammaticaliteit van niet-lokale binding uit adjunct eilanden en de marginale aanvaardbaarheid van niet-lokale binding uit bijzin eilanden en (ii) het feit dat niet-lokale binding geblokkeerd wordt door *wh*-antecedenten (vraagwoord-antecedenten) en kwantificatiele antecedenten. De in (ii) genoemde blokkering is geïnterpreteerd als een schending van *Relativized Minimality*. Met betrekking tot de theorie van syntactische eilanden heb ik ontdekt dat de niet-lokale binding uit een complexe DP gevolgd door een CP eiland en uit vraagwoord-eilanden niet tot ongrammaticale resultaten leidt, maar zie (i). Ik heb voorgesteld dat de manier waarop eilanden interageren met niet-lokale binding sterk afhangt van de elementen die aan de eilanden voorafgaan. Voorafgaande elementen met kwantificatiele eigenschappen (vraagwoorden) blokkeren niet-lokale binding, terwijl elementen zonder deze eigenschappen (het voegwoord *că* (dat) en het *wh*-voegwoord *dacă* (als) niet-lokale binding toestaan.

Ik heb drie beschrijvende generalisaties geformuleerd over niet-lokale binding in het Roemeens. De eerste zegt dat Roemeense niet-lokale anaforen gevoelig zijn voor effecten van *relativized minimality*, die veroorzaakt worden door *wh*- en kwantificatiele antecedenten. De tweede constateert dat niet-

196 Dutch summary

lokale binding relaties in het Roemeens voortkomen uit finiete ingebedde zinnen (conjunctieve en indicatieve zinnen). De derde zegt dat niet-lokale bindingsrelaties in het Roemeens gevoelig zijn voor het *Blocking Effect*, dat ook bekend is uit Oost-Aziatische talen.

De basis-theorie over *sine* is dat het morfologisch gescheiden kan worden in twee delen, *si-ne*. Het eerste deel, *si-* gespecificeerd voor ϕ features (een specificatie voor de derde persoon en een voor inherent enkelvoud). Het tweede deel, *-ne*, codeert een *operator feature*. Het bi-morfemische karakter van *sine* bepaalt zijn gedrag. Met andere woorden, dit bepaalt dat de kenmerken van *sine* zowel lokaal (ϕ features) als niet-lokaal (*operator features*) gecheckt kunnen worden. Nu de bi-morfemische aard van *sine* bepaald is, kunnen de beschrijvende generalisaties die ik hiervoor noemde eenvoudig afgeleid worden. De eerst volgt uit het feit dat, gezien zijn morfologisch geëncodeerde *operator feature*, de kale reflexief eenzelfde combinatie van features heeft als –de tussenkommende *wh* en kwantificatiele antecedenten. De tweede generalisatie volgt uit het feit dat alleen finietheid (*finite Tense*) een volledig ontwikkelde linkerperiferie heeft, die vraagwoorden kan toestaan (en ook andere zinnen, zoals met een gefocaliseerde XP). Dit houdt in dat alleen finietheid een relevant *operator feature* heeft, dat nodig is voor het toestaan van *wh-movement* (vraagwoord-verplaatsing). Ik heb voorgesteld dat niet-lokale binding hetzelfde type *operator feature* nodig heeft. Als het relevante *operator feature* niet aanwezig is op *Tense*, is alleen de lokale interpretatie mogelijk, en krijgt de *operator* van de kale reflexief een default-waarde. De derde generalisatie volgt uit het feit dat het computationele systeem een puur formele *feature check* uitvoert in wat Chomsky (1995) *checking configurations* noemt, als een eerste deel van de operatie *Agree*. Als de kenmerken van *sine* zich verplaatsen naar de tussenliggende T, bevinden ze zich precies in zo'n *checking configuration*. De 'check' leidt tot een mismatch, en dit resulteert in het *Blocking Effect*. Ik heb voorgesteld dat het *Blocking Effect* gezien kan worden als een test voor de tussenliggende landingsplaatsen die de features van *sine* "doorlopen". Het is algemeen bekend dat *wh-* verplaatsing ook gebruikt maakt van zulke tussenliggende landingsplaatsen. In het Roemeens worden deze tussenliggende plaatsende gemarkeerd door de subjectinversie die altijd met *wh-*verplaatsing gepaard gaat (het subject blijft *in situ*). Mijn voorstel is dat gevoeligheid voor het *Blocking Effect* hetzelfde resultaat oplevert voor tussenliggende landingsplaatsen van niet-lokale bindingsrelaties.

Curriculum vitae

Anca Sevcenco was born on May 24th 1971, in Bucharest, Romania. She got her BA in the English and Romanian language and literature from Bucharest University in 1994. She followed the Theoretical Linguistics MA program at the University of Bucharest and graduated in 1996. From 1998 to 2001, she taught English and linguistics to the undergraduate students at the University of Bucharest, where she has a tenure-track position. In 2001, she was awarded a Fulbright Junior research grant and she spent 10 months at the University of California, at Davis. She enrolled in the Ph.D program at UiL OTS, Utrecht University in July 2003.