

# Slow growth, stress response and aging in

Citation and similar papers at [core.ac.uk](http://core.ac.uk)

brought

provided by Utrech

Langzame groei, stress respons en veroudering in *Saccharomyces cerevisiae*

(met een samenvatting in het Nederlands)

## Proefschrift

ter verkrijging van de graad van  
doctor aan de Universiteit Utrecht  
op gezag van de Rector Magnificus,  
Prof. Dr. W.H. Gispen, ingevolge  
het besluit van het College van  
Promoties in het openbaar te  
verdedigen op maandag 23 februari  
2004 des middags te 14.30 uur

door

**Victor Jacob Winter**

geboren op 24 februari 1975, te Zeist

Promotoren:

**Prof. Dr. Ir. C.T. Verrips**

(Verbonden aan de leerstoelgroep Moleculaire Celbiologie, Faculteit Biologie, Universiteit Utrecht)

**Prof. Dr. J. Boonstra**

(Verbonden aan de leerstoelgroep Moleculaire Celbiologie, Faculteit Biologie, Universiteit Utrecht)

**Prof. Dr. A.J. Verkleij**

(Verbonden aan de leerstoelgroep Moleculaire Celbiologie, Faculteit Biologie, Universiteit Utrecht)

The Research described in this thesis was performed at the department of Molecular Cell Biology within the Institute of Biomembranes, Faculty of Biology at the Utrecht University in the Netherlands and financially supported by Unilever Research Vlaardingen, The Netherlands.

Paranimfen: **Fiona Winter**  
**Raoul Oude Engberink**

Omslag: **Victor Winter**  
(afbeelding: gisten met meerdere budscars)

Reproductie: **Ridderprint offsetdrukkerij b.v. Ridderkerk**

ISBN: **90-393-3613-X**

‘...zal ik stoppen, of zal ik doorgaan...’

uit ‘steentje in mijn sok’ van Winter & van Staveren

‘A lot of people are hostile to science because it demystifies nature. They prefer the mystery. They would rather live in ignorance of the way the world works and our place within it. For me, the beauty of science is precisely the demystification, because it reveals just how truly wonderful the physical universe really is. It is impossible to be a scientist working at the frontier without being awed by the elegance, ingenuity, and harmony of the lawlike order in nature. In my attempts to popularize science, I am driven by the desire to share my own sense of excitement and awe with the wider community; I want to tell people the good news.’

Paul Davies in his acceptance speech of the Templeton Prize 1995

## Table of contents

Chapter 1	General introduction	7
Chapter 2	Slow growing <i>Saccharomyces cerevisiae</i> show increased expression levels of genes involved in oxidative stress protection and of structural subunits of the proteasome	35
Chapter 3	The expression of several components of the thioredoxin system after exposure to hydrogen peroxide is dependent on the phase of the cell cycle.	63
Chapter 4	Response of TRX2-promoterconstruct to hydrogen peroxide in <i>Saccharomyces cerevisiae</i> is cell cycle dependent	83
Chapter 5	Aged yeast cells show a specific decrease in response to oxidative stress	101
Chapter 6	Screening for new antioxidants	125
Chapter 7	General discussion	137
Appendix I	References & Literature	143
Appendix II	Nederlandse samenvatting	155
Appendix III	Thanks & Curriculum vitae	159



*1*

*G*

*eneral introduction*

# 1.General Introduction

## 1.1. Aging in general

Aging has always been an intriguing phenomenon and numerous attempts have been made to elongate lifespan or to find ways to obtain immortality. Finding the right composition of the so-called philosopher's stone, which should do the trick, would result in wealth and health until eternity (figure 1.1). Although science has moved on since the Middle Ages, no one found a stone with healing properties, or at least made it public, but the interest in aging did not fade. The approach shifted from finding a cure for aging to understanding the causes of aging, and the alchemists turned into scientists. As we will see in a moment it can be quite confusing to talk about causes of aging because nature's emphasis is not on aging but on survival and corresponding longevity.



**Fig 1.1:** Fragment of 'The alchemist' by Adrien van Ostade (1610-1685).

Aging is a difficult phenomenon, both to understand and to study, and there are several reasons why that is the case. First of all, different kinds of extrinsic causes of death blur the picture of aging whilst potentially at the same time contribute to aging. Car accidents contribute considerably to mortality rates but are of course not involved in aging. A disease like malaria has obvious extrinsic aspects but how about cardiovascular disease or other age-related diseases? Grey hair is an example where it is clear that although it correlates very nicely with age, it is no cause of aging. However, with a lot of diseases it is less obvious whether they derive from, or contribute to, the aging process. Secondly, the vast amount of processes involved, spanning metabolism, genetic stability, stress responses, caloric restriction, and many others, makes it hard to develop a clear picture. Moreover, studying human aging takes a lot of time, which scientists do not always have. However, there are ways of circumventing this problem by using model organisms, which will be discussed later. Other problems are more of semantic origin. Using terms as lifespan and life expectancy, senescence, aging, longevity and viability without a proper definition leads to confusion and



misinterpretations. The (maximum) lifespan is the (maximal) age someone reaches while life expectancy is the average age that someone probably will reach. The life expectancy has risen by 30-40 years for some countries over the last century by effectively reducing health risks. On the contrary, in areas like the sub-Saharan Africa, life expectancy sticks at 47 years on average with a dip to 26 years for Sierra Leone (WHO, 2002). This has obviously everything to do with extrinsic causes of death and is not related to the 'normal' aging process. The maximum lifespan has probably remained constant over the years (Hayflick, 2000) although that is more difficult to prove. Longevity is used, as an antonym for aging while viability is the ability to remain viable even under adverse conditions.

### 1.1.1. Definition of aging

Aging has been defined many times from 'what happens to an organism over time' to 'an increased liability to die, or an increasing loss of vigour, with increasing chronological age, or with the passage of the life cycle' (Arking, 1998). Although there are many more of these definitions they all more or less encompass four aspects. Changes during the aging process must be i) deleterious, ii) progressive, iii) intrinsic and iv) universal for the species (Arking, 1998). Senescence is usually only used to describe the last stages of life but more general also as a synonym for aging.

There are different levels at which the concept of aging can be approached. First, the way in which evolutionary biologists analyze the phenomenon will be described. Then the molecular biologist approach will be discussed in more detail. Although several model organisms can be used to obtain information about the aging process, the yeast *Saccharomyces cerevisiae* was chosen as the focus of this thesis, and the reasons for this choice are also discussed in the following sections.

### 1.1.2. Different evolutionary aging models

One of the first ideas about the cause of aging was the existence of a genetic program that at a certain stage will mechanistically decide like a 'grim reaper' that the organisms' time has come. Advantages of a system like this would be that population size would be limited to secure food stocks and that there would be an acceleration of turnover of generations to be able to adapt faster to changing environments. However, from an evolutionary point of view it is hard to see how this could have been developed.

If one member had a dysfunctional ‘grim reaper’-gene, for instance because of a mutation, it would have had the advantage and quickly out compete others. This reasoning neglects the ‘selection on group level’-concept, which states that certain altruistic behaviour beneficial on group level whilst detrimental on individual level can be selected for during evolution also known as inclusive fitness or Hamilton’s rule. However, these theories seem to have been applied mostly to mammalian species, although recently several reports claim to observe this altruistic behaviour in unicellular organisms, for instance the apoptosis-like features in *Saccharomyces cerevisiae* (Madeo *et al.*, 1999; Frohlich and Madeo, 2000; Zimmer, 2001). The explanation of these observations could reinforce group selection theory in unicellular organisms. However, arguments in favour of this concept remain obscure. It must be strongly emphasized here that the most probable explanation remains that there are no genes regulating aging but there are only genes regulating survival/viability and thus indirect longevity (Kirkwood, 2002; Bitterman *et al.*, 2003).

### 1.1.3. Mutation accumulation

Natural selection weakens with age because genes that are deleterious only at post-reproductive stages in life are passed on without any problem (Kirkwood and Austad, 2000). To give an example of early and late life defects: two disorders causing rapid aging phenotypes known as Hutchinson-Gilford syndrome (progeria) and Huntington’s disease display distinctive features. Progeria is a rare disorder in which childhood is characterized by a rapid aging phenotype. On the contrary, Huntington’s disease is much more widespread because it manifests itself only at a later age giving the, up until then, unknowing victims the chance to pass their genes on to the next generation. Mutations that do not cause any problems before or during reproductive phase but start to cause malfunctions at later stages in life are not selected against during evolution and thus accumulate, hence the name ‘mutation accumulation’. Because this process is random, the theory predicts that there has to be a lot of genetic variance between lineages. Another consequence of this theory is that using genetic manipulation to select for late life fitness will not have negative consequences on early life fitness (Hughes *et al.*, 2002).

#### 1.1.4. Antagonistic pleiotropy / Disposable soma theory

The antagonistic pleiotropy theory is more or less comparable to the mutation accumulation theory, because it also assumes that late in life deleterious mutations/genes will accumulate and take care of degeneration of the body. And again this is caused by the weak natural selection during the later stages of life. However, this theory states that the accumulation of these mutations is an effect of the optimal allocation of limited metabolic resources between somatic maintenance (efficient DNA-repair, protection against stress) and reproduction, hence also the name 'disposable soma' (Kirkwood and Holliday, 1979).

A trade-off example in the aging field is the *Caenorhabditis elegans daf2* mutant. This mutant lives twice as long as the wild type, and has a delayed but extended reproductive lifespan (Dillin *et al.*, 2002). So although the amount of progeny could be higher in the mutant, the wild type starts earlier with producing offspring which gives it an evolutionary advantage. Another disadvantage of lacking DAF2 could be that in the *daf2* mutant the insulin-signalling pathway is disturbed, which often leads to entering of the worms into the dauer phase. This dauer phase is some sort of hermit-state of the worm in which nothing happens anymore, let alone reproduction. The dauer state is an excellent way of surviving a longer period of food scarcity. However, a *daf2* mutant even enters the dauer phase when there is enough food. Under these circumstances the wild type *C. elegans* will divide and probably overgrow the *daf2* mutant (Kenyon, 2001).

#### 1.1.5. Implications of the different evolutionary models

Differences between mutation accumulation and antagonistic pleiotropy are present but subtle and in my opinion superficial. One implication of the mutation accumulation theory is that because the mutations are random, more genetic variance will occur between species and individuals. Antagonistic pleiotropy theory predicts that mutations will be less random because there has to be a beneficial effect of these mutations in early life. It states therefore that there will be more analogies between species regarding these mutations. These differences are only distinguishable by accurately measuring mutation rates and using reliable statistical tools. Hughes *et al.* (Hughes *et al.*, 2002) performed these kinds of experiments and concluded that there are more indications in favour of the mutation accumulation theory. However, these theories are not mutually exclusive. The main point from these theories is that they

illustrate that organisms are only built to last up until the reproductive phase. Whatever happens after this is not specifically regulated because of the weakened force of natural selection at the post-reproductive stages.

### 1.1.6. Trade-offs

An example of a trade-off was already given for *C. elegans* but do they also occur in other organisms? Some claims indicate that a trade-off between fertility and lifespan exists in humans, mice and fruit flies. Experiments have been conducted in which offspring of young and old *Drosophila melanogaster* were collected. Because the old individuals have a larger chance to die of aging before the offspring is collected, you select for longevity in this offspring. This process was repeated to breed eventually a long living and a short living lineage. It appeared however that the long living lineage was less fertile early in life than the short living (Kirkwood and Austad, 2000). This points again to a trade-off between longevity and fertility. There has to be an optimum however, because new flies are not immediately capable of producing offspring. Such experiments are of course not possible in humans, but demographic research spanning several ages has concluded that a long life is at the cost of reproductive success (Westendorp and Kirkwood, 1998). The problem with these kinds of studies is always that (breeding) conditions are very diverse so conclusions have to be handled carefully.

So far evolutionary argumentation shows there is probably no genetic plan, trade-offs are likely to occur and exogenous causes play a part in aging. But then, why do certain flies and people live longer than others? What is the molecular background behind it? As mentioned before, several mutations were found in the long-lived *D. melanogaster* strains, either made by insertional mutagenesis or by selection as mentioned above. For instance, a *Chico* mutant contains a defective insulin receptor substrate protein, hereby changing the insulin/IGF signalling (Clancy *et al.*, 2001). This is consistent with the earlier mentioned findings with regard to the insulin signalling system in *C. elegans* (Tatar *et al.*, 2001). The fact that nutrient signalling is very important for determining longevity is substantiated by the observations of a peculiar phenomenon called ‘caloric restriction’. Caloric restriction (CR) is the regime in which the daily intake of calories is 25-50% lower compared to an *ad libitum* fed control. McCay observed (in 1935) that his lab rats lived considerably longer when fed less (McCay *et al.*, 1935). This approach is the only method known to increase longevity in

mammals so far. After this first observation, CR has also been shown in *C. elegans*, *S. cerevisiae*, and other model organisms (Jiang *et al.*, 2000). There is even some preliminary evidence gathered that these processes can also occur in humans, as observed for instance in Okinawa (Japan) (Mimura *et al.*, 1992). The way in which CR is able to increase lifespan is not completely elucidated yet. First it was thought that CR is closely linked to the oxygen radical theory through its effect on metabolism, which will be discussed further on (Sohal and Weindruch, 1996). By cutting back on the amount of calories (or better joules), metabolism would be slowed down and fewer radicals would be generated (Heilbronn and Ravussin, 2003). Experiments done with *S. cerevisiae* show that during a regime in which cells were deprived of excess nutrients caloric restriction features were observed too (Lin *et al.*, 2000). However, besides oxygen radicals also other metabolism-associated molecules like NAD<sup>+</sup> seem to be involved (Anderson *et al.*, 2002). Although there is no insulin receptor in yeast, there are other pathways present involved in nutrient signalling and they seem to be involved in aging as well. But why use a unicellular organism as yeast for aging research? And how is nutrient signalling involved in aging?

## 1.2. Yeast aging

### 1.2.1. *Saccharomyces cerevisiae* as a modelsystem for aging

Although yeast has proven to be a qualified model for different kinds of research, one could doubt whether it is also a good model to study the aging process. It took some time before it was found that yeast cells age. Before the crucial experiments by Mortimer and Johnston (Mortimer and Johnston, 1959) it was commonly believed that yeast could divide forever. However, *S. cerevisiae* is an asymmetrically budding yeast, providing an easily recognizable difference between the mother cell, or soma, and her offspring, or germ line. Besides the difference in size, the mother cell is clearly distinguishable by the bud-scar left behind after separation of mother and daughter. When there is no difference between the soma and the germ line, for instance with *Escherichia coli*, then the whole concept of aging is of course not applicable (Nystrom, 2002). Mortimer and Johnston showed by using a micromanipulator with which they removed newly produced daughter cells, that individual mother cells could only produce a limited number of progeny. A limit to the amount of offspring is not the same as an aging process per se. Yet, there are also several phenotypic changes occurring during its lifespan, like the development of surface wrinkles, the increase in vacuolar size and finally death, which are usually contributed to the aging of the yeast cell (table 1.1) (Sinclair *et al.*, 1998a; Jazwinski, 1999).

**Table 1.1:** Phenotypic changes during the yeast's life.

#### Characteristics of old yeast

---

Increasing cell size

Altered cell shape

Develops surface wrinkles

Budscar number increases

Cell wall chitin increases

Vacuole size increases

Cell cycle time increases

Mating ability (in haploids) decreases

Fragmentation of nucleolus

There are several advantages for choosing *S. cerevisiae* for doing aging research.

- It ages rather fast.
- It is relative easy to determine the replicative age of a cell (by counting the bud scars).
- At least several homologies have been found between aging yeast and higher eukaryotes concerning aging, for example the insulin/glucose signalling and caloric restriction features (Bitterman *et al.*, 2003).
- The aging of yeast can be controlled by external factors and can be easily manipulated.
- It is easy to cultivate cells under controlled circumstances.

Furthermore from a practical point of view there are some characteristics that make *S. cerevisiae* a convenient modelorganism.

- The genome of *S. cerevisiae* was the first eukaryotic genome that was elucidated, so there are already many identified genes and there is a wealth of information available about them.
- The molecular techniques are well developed. It is rather easy to make (or buy) knock-out mutants and devise reporterconstructs.

### 1.2.2. Chronological vs. replicative aging

Aging in yeast can be measured in two different ways; there is replicative aging and chronological aging. With replicative aging, cells bud off a limited amount of daughter cells. In this case lifespan of *S. cerevisiae* is usually measured by number of divisions instead of using a chronological time-scale. If the survival curve of *S. cerevisiae* is plotted as a function of the amount of divisions, an increasing age-specific mortality is observed, which by definition is a hallmark of aging (figure 1.2) (Jazwinski *et al.*, 1989; Sinclair *et al.*, 1998a).

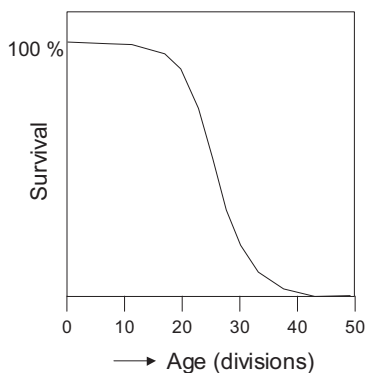


Figure 1.2: Survival rates for yeast show an increasing age-specific mortality when plotted against number of divisions.

Chronological aging has also been subject of studies in yeast, but then usually cells in stationary phase are analyzed, which are not very metabolically active depending on the environment. These non-dividing yeast cells could be a good model for differentiated non-dividing mammalian cells, however a potential drawback is the difference in metabolic activity (Gershon and Gershon, 2000; Jakubowski *et al.*, 2000; Fabrizio *et al.*, 2001). On the other hand, stationary cells kept in defined expired medium seem to continuously have higher metabolic rates and a shorter lifespan than cells kept on water or rich media (Longo *et al.*, 1996; Jakubowski *et al.*, 2000).

The two ways in which yeast lifespan analysis can be done reveals discrepancies and similarities between the approaches, with the most striking example being Ras2. Deletion of this protein amongst other things involved in nutrient signalling through the PKA pathway leads to an extension in lifespan for stationary phase cells and to a decrease in lifespan for dividing cells (Longo, 1999). However, when the adenylate cyclase Cyr1 (or Cdc35), also involved in the PKA signalling pathway is mutated, both the replicated and the chronological lifespan are extended (Lin *et al.*, 2000; Fabrizio *et al.*, 2001). These observations plus the observation of Ashrafi (Ashrafi *et al.*, 1999) that passage through stationary phase advances replicative aging shows that the two aging modes are related but that at the same time each has their own characteristics.

### 1.2.3. Growth under adverse circumstances

The whole purpose of a yeast cell, and actually of more or less every biological system, is to grow and produce daughter cells, and it will do anything to maintain these processes. However, growth conditions are usually far from optimal so the yeast cell has devised protective mechanisms to overcome insults and starvation periods. There are specific responses in case the cell experiences oxidative stress, osmotic stress, temperature stress and nutrient limitation but there is also a general response: a decrease in growth rate. During very harsh environmental conditions the cell is inclined to completely halt growth until conditions improve. At these moments energy is invested in reinforcing the soma at the cost of reproduction. This is confirmed by earlier mentioned observation that prolonged stay in stationary phase shortens subsequent replicative lifespan (Ashrafi *et al.*, 1999). An example of reinforcing the soma is the synthesis of the stress protectant trehalose during forced slow growth conditions (Paalman *et al.*, 2003). Moreover, mutants impaired in trehalose synthesis are not able to survive stationary phase very long (Silljé *et al.*, 1999) highlighting its importance for



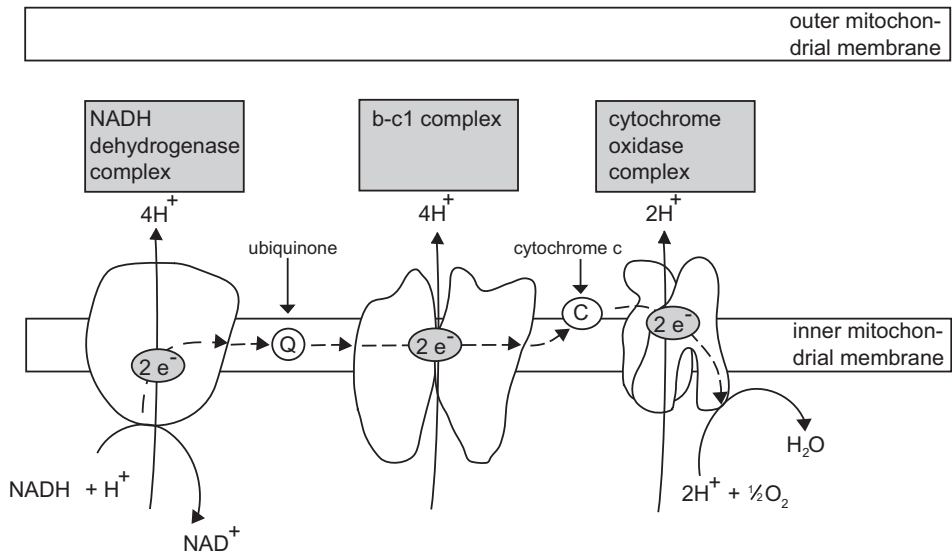
survival. Furthermore, trehalose accumulates during exposure to all kinds of different stressors and is able to stabilize proteins and membranes, according to Verwaal and references therein (Verwaal, 2003). Regulation of trehalose accumulation is dependent on the growth rate because in a nitrogen limited chemostat culture, trehalose is only present at low growth rates although there is plenty of glucose available (Paalman *et al.*, 2003). Trehalose is also able to protect the cell against oxidative stress, presumably by acting as a free radical scavenger (Benaroudj *et al.*, 2001). Whether the synthesis of trehalose in this case is regulated by the oxidative stress directly or by the decrease in growth rate is not clear yet although Yap1, which is an oxidative stress specific transcriptional activator, is necessary for hydrogen peroxide induced trehalose synthase expression (Lee *et al.*, 1999b). This suggests at least an additional way of regulating expression during oxidative stress conditions.

As mentioned above, experiments done with *S. cerevisiae* show that during a regime in which cells were deprived of excess nutrients caloric restriction features were observed. First of all the effect of decreasing glucose concentrations from 2.0 % to 0.1% in the media gradually increases replicative lifespan, secondly it also slows down the aging phenotype (Jiang *et al.*, 2000; Lin *et al.*, 2000). Some question marks can be placed next to these experiments because the mentioned glucose concentrations are the initial concentrations and will decrease rapidly during the experiment, so results from these experiments should be treated carefully. Fed-batch or chemostat cultures would yield more accurate and reproducible results because in these cases external glucose concentrations are kept constant.

#### 1.2.4. Oxygen stress and aging

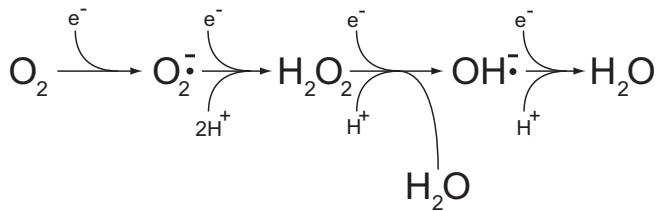
One of the key-players in the aging field are the oxygen radicals. Oxygen radicals are defined as molecular derivatives of oxygen with one or more unpaired electrons. Because of these unpaired electrons they are ‘eager’ to react with other molecules. In biological systems, all kinds of constituents ranging from DNA, to phospholipids to proteins and metabolites can be altered in their structure. These changes can be amongst other things, DNA double strand breaks, lipid modifications and dysfunctional enzymes. The term Reactive Oxygen Species (ROS) is a broader definition also covering for instance hydrogen peroxide. Hydrogen peroxide is not an oxygen radical in the strict sense because it has no unpaired electrons. However it is an important intermediate, so to include it, the term ROS was coined.

Before oxygen radicals were identified as being an important factor in biological systems, several observations were made that coupled metabolic rates to longevity. It was found for instance that the heartbeat rates of different species correlated nicely to their lifespan (Livingstone and Kuehn, 1979). Although there were several exceptions, this led in the beginning of the 20<sup>th</sup> century to the formulation of the ‘rate-of-living’ hypothesis. In 1956 Denham Harman was the first to postulate that this correlation could be a consequence of the production of oxygen radicals during metabolism (Harman, 1956). In 1972 Harman adjusted his theory and made it more precise after which it became known as the ‘Mitochondrial theory of aging’. ‘Mitochondrial’, because the origin of most of these radicals would be the mitochondria. This does not mean that anaerobic growing species are immortal because there are also other ways of generating radicals. The generation of ROS by mitochondria makes perfect sense because these organelles provide the cell with the required energy by stepwise oxidation of nutrients. It turned out that several steps in this process, for instance in the electron transport chain (see figure 1.3), could cause leakage of electrons onto oxygen. The three subunits (NADH dehydrogenase, b-c1 complex and the cytochrome oxidase complex) are supposed to transfer the electrons from the NADH, generated for instance in the oxidative phosphorylation, to oxygen to turn it into water.



**Figure 1.3:** The three subunits of the electron transport chain. The electrons from the reducing equivalents NADH are transferred to ubiquinone and cytochrome c subsequently to end up in water molecules. During these transitions electrons can ‘leak’ leading to oxygen radicals.

However, these systems are not completely flawless and some electrons react with oxygen turning it into harmful radicals like superoxide (see figure 1.4). The exceptions to the heartbeat vs. lifespan rule could now also be accounted for because it was found that rates of production of ROS by mitochondria differed per species (Ku *et al.*, 1993).



**Figure 1.4:** Stepwise reduction of oxygen to subsequently superoxide, hydrogen peroxide, hydroxyl radicals and finally water.

### 1.2.5. Oxygen stress defences

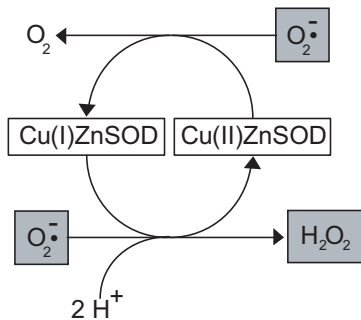
Being able to use oxidative phosphorylation to obtain energy comes together with the adverse side effects of the damaging oxygen radicals. Cells adapted to these threats and devised several protection mechanisms, usually classified into different groups (Moradas-Ferreira *et al.*, 1996; Oku *et al.*, 2003).

- Antioxidant enzymes: glutathione reductases, glutathione peroxidases, thioredoxin reductases, thioredoxin peroxidases, superoxide dismutases, catalases.
- Small antioxidant molecules: glutathione,  $\gamma$ -glutamylcysteine, vitamin E, vitamin C.
- Trehalose.
- Repair and turnover systems: ubiquitin system, DNA base excision repair.

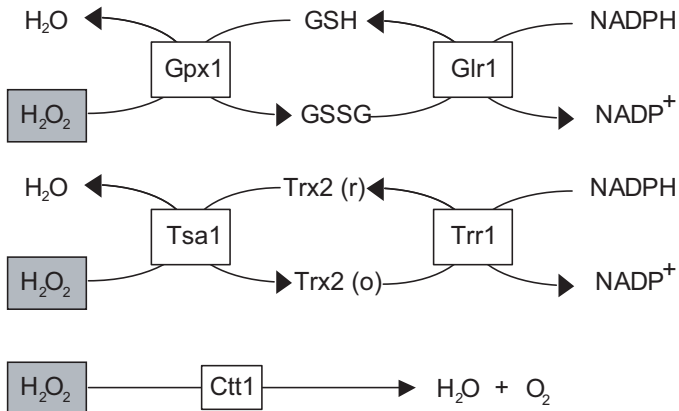
Superoxide radicals can be scavenged by superoxide dismutases, one present in the mitochondria (Sod2) and one in the cytosol (Sod1). The cytosolic dismutase contains a copper ion with which electrons are transferred to superoxide radicals to form hydrogen peroxide as depicted in figure 1.5A (Hart *et al.*, 1999). The formed hydrogen peroxide can subsequently be degraded to water and oxygen by several mechanisms. Glutathione can be oxidized to GSSG catalyzed by the glutathione peroxidases and reduced again by the glutathione reductase at the expense of reduction of NADPH (figure 1.5B) (Inoue *et al.*, 1999). The thioredoxin system behaves in a similar fashion

also shown in figure 1.5B. With help of the thioredoxin peroxidases, the thioredoxin is oxidized and subsequently reduced again by the thioredoxin reductases at the expense of NADPH (Inoue *et al.*, 1999). The catalases, one present in the peroxisomes and one in the cytosol, have another way of dealing with hydrogen peroxide by converting it directly to water and oxygen (figure 1.5B). However, there are differences in reactivity, as for instance a deletion strain of the first step in the glutathione biosynthesis is very sensitive to hydrogen peroxide while a catalase deletion strain is not (Grant *et al.*, 1998).

A



B



**Figure 1.5:** Several important antioxidant systems in *S. cerevisiae*: A: Cu/Zn superoxidedismutase, B: glutathione, thioredoxin and catalase antioxidant systems. GSH: glutathione, GSSG: oxidized glutathione, Gpx1: glutathione peroxidase, Glr1: glutathione reductase, Trx2 (r): reduced thioredoxin, Trx2 (o): oxidized thioredoxin, Tsa1: thioredoxin peroxidase, Trr1: thioredoxin reductase, Ctt1: cytosolic catalase. (Hart *et al.*, 1999) (Moradas-Ferreira *et al.*, 1996)

The induction of these antioxidant proteins in yeast is tightly regulated by transcription factors like Yap1 and Skn7, which are activated by oxygen radicals (Morgan *et al.*, 1997; Lee *et al.*, 1999b). Also Msn2 and Msn4 play a role in stress protection although they are more responsible for a general stress response (Martinez-Pastor *et al.*, 1996). Apparently the cell has organized its defences against ROS rather well. However, defences against ROS are not unlimited. At a certain amount of exogenously added hydrogen peroxide, the cell will die. Again, there is a balance between investing resources in maintenance, in this case defence against ROS, or in producing offspring.

The superoxide dismutase converts the superoxide into hydrogen peroxide, which in turn is neutralized by the glutathione, thioredoxin or catalase systems. However, these systems are not flawless, as a result radicals are able to escape these defence mechanisms and cause damage to cellular constituents. Hypothetically, this can turn into a vicious circle if these radicals damage the mitochondrial DNA. Because if so, subunits (coded in the mtDNA) of oxidative phosphorylation enzymes can become dysfunctional, which alternately could lead to more escaping electrons and thus more radicals (Mandavilli *et al.*, 2002; Wei and Lee, 2002).

Damage done by these radicals can vary from mutating nucleotides in mtDNA, for instance the formation of 8-hydroxydeoxyguanine (8-OHdG), to the formation of carbonyls in proteins. It appears that the formation of 8-OHdG in mtDNA of different mammals is inversely correlated with the lifespan of these species (Barja and Herrero, 2000). In *S. cerevisiae* it was observed that superoxide dismutase activity is essential for stationary phase survival or chronological aging (Longo *et al.*, 1996). Moreover, overexpression of Sod1p and Sod2p leads to extension of chronological lifespan (Fabrizio *et al.*, 2003). Also during replicative aging the deletion of Sod1p entails a major decrease in lifespan (Wawryn *et al.*, 2002) but the effect of a deletion strain of Sod2p during replicative aging is nil.

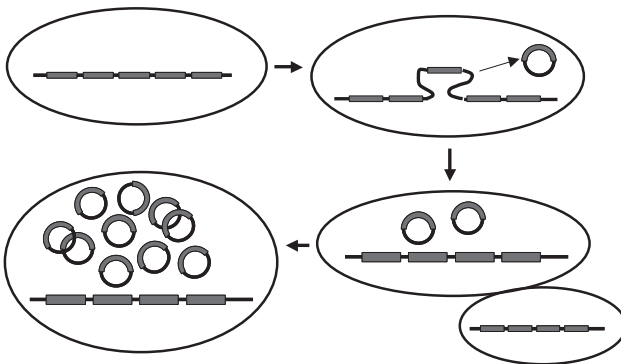
However, the role of ROS during caloric restriction in yeast is less clear. It is hard to align metabolism-associated-ROS with caloric restriction because there is actually an increase in respiration when sugar levels are decreased. If indeed oxygen radicals escaping from the mitochondria were the major damaging agents during replicative aging in yeast, then caloric restriction should decrease lifespan. Lin *et al.* (Lin *et al.*, 2000) shows that the caloric restriction in yeast affects NAD<sup>+</sup> levels, in turn

activating the histone deacetylase Sir2, which subsequently increases silencing and rDNA stability.

There is other data concerning caloric restriction and Sir2 activity. Experiments by Kaeberlein *et al.* showed that 2.0 % glucose is actually a poor concentration with respect to lifespan elongation because both decreasing to 0.5 % and increasing to 10 % led to an increase in lifespan (Kaeberlein *et al.*, 2002). The effect of lowering the concentration was explained by its effect on respiration while the effect of the increase in glucose was attributed to a shift from glycolysis to trehalose and glycerol synthesis, which is an osmotic stress response. Exposing yeast cells to 10 % glucose is thus actually a stressful condition. During the synthesis of glycerol NAD<sup>+</sup> is formed subsequently leading again to more active Sir2. This takes us to a second molecular mechanism involved in aging in yeast, silencing dependent genetic stability.

### 1.2.6. Genetic stability and aging

As mentioned before, oxygen radicals are not the only metabolism associated molecules involved in aging. There are several clues that NAD<sup>+</sup> is a protagonist of longevity. It is supposed to be involved in regulating genomic stability by activating Sir2. In the yeast DNA, there is a part that codes for ribosomal RNA (rRNA). This 9.1 kb sequence is an active subunit of the ribosomes and is present in about 100-200 copies arranged next to each other on chromosome XII. These multiple copies are needed because the cell needs a lot of ribosomes to translate all the mRNA into proteins. Because of its repeating sequence it is susceptible to homologous recombination. This can lead to the excision of a circular piece of this rDNA from the chromosome (see figure 1.6). During division the DNA, including the Extra Ribosomal



**Figure 1.6:** The formation of Extrachromosomal Ribosomal DNA Circles (ERCs). The first step is the excision of a circle by homologous recombination, these circles are then replicated and segregated asymmetrically between the mother and the daughter cell leading to accumulation of ERCs in the mother cell.

DNA Circle (ERC), duplicates and segregates into the daughter and the mother. However, the sorting is unequal and most ERCs stay with the mother cell. If this happens several times in a row then it does not take a mathematician to determine that, because of the accumulation of ERCs in the mother cell, the amount of DNA will increase exponentially. Sinclair *et al.* claims that this accumulation eventually leads to cell death because the yeast cell is just not able to replicate these huge amounts of DNA (Sinclair and Guarente, 1997).

Sir2, an NAD<sup>+</sup> dependent histone deacetylase, prevents the excision of these ERCs from the DNA. Histone deacetylases are involved in removing acetyl groups from the protein complexes, around which the DNA is wound: the histones. The absence of the acetyl groups leads to a more condensed state of the chromosomes, which makes it transcriptionally inactive, also known as 'silenced' DNA. (Chang and Min, 2002; Jiang *et al.*, 2002)

Overexpression of Sir2 leads to an increase in replicative lifespan (Kaeberlein *et al.*, 1999) that, accordingly to Lin *et al.* (Lin *et al.*, 2000), fits the caloric restriction observations. They hypothesize that when low concentrations of glucose are present, the cells are more eager to use their mitochondria to obtain energy, which leads to a higher turnover of NADH to NAD<sup>+</sup>. Because Sir2 is NAD<sup>+</sup> dependent this would lead to increased activity of Sir2 and thus to an extension of lifespan. How exactly higher turnover of NADH would lead to a more active Sir2 remains unclear, also because steady state levels of NAD<sup>+</sup> seem not to change (Anderson *et al.*, 2002). However these measurements were done on whole cell extracts which leaves the possibility open that local NAD<sup>+</sup> concentrations do vary. Next to this is the observation that nicotinamide, which is the reaction product of NAD<sup>+</sup> with Sir2, is a strong inhibitor of Sir2 activity *in vitro*. This raises the possibility that not NAD<sup>+</sup> but nicotinamide regulates Sir2 activity (Anderson *et al.*, 2003).

The importance of NAD<sup>+</sup> is further strengthened by experiments influencing the NAD<sup>+</sup> salvage pathway. This pathway is involved in recycling nicotinamide, which is a product of the Sir2 reaction, via nicotinic acid to NAD<sup>+</sup>. The protein catalyzing the conversion of nicotinamide to nicotinic acid is called Pnc1. Overexpression of this protein increases replicative lifespan with 70% compared to wildtype (Anderson *et al.*, 2003). Caloric restriction was not able to further increase lifespan. Furthermore it was shown in the same publication that nicotinamide inhibits Sir2 activity. A strange

observation with respect to aging and  $\text{NAD}^+$  is that the concentration of  $\text{NAD}^+$  seems to increase during aging although not much (Ashrafi *et al.*, 2000). This does not fit with the increase in genetic instability due to loss of Sir2 activity. However,  $\text{NAD}^+$  concentrations could vary locally or the increase might be a countermeasure to insure active Sir2.

So although it is clear that  $\text{NAD}^+$  is involved in regulating Sir2 activity it is not clear how Sir2 but also the other histone acetylases and deacetylases are induced or repressed during aging. It could be that ROS play an active role in this regulation. There is some evidence that hydrogen peroxide can induce histone acetylation although it is not clear whether this goes via Sir2 (Rahman *et al.*, 2002). Whether these results can be extrapolated to higher eukaryotes remains to be seen. The existence of ERCs outside the yeast system still has to be established, thus it could therefore be a yeast specific aging consequence (Gershon and Gershon, 2000). However, it can be a symptom of a more universal mechanism involving silencing and changes in gene transcription.

### 1.2.7. Other genetic components?

As has been demonstrated above, there are several genes identified involved in determining yeast replicative and chronological lifespan, summarized in table 1.2 (partly taken from (Bitterman *et al.*, 2003)). In this table, only those genes were taken into account that increase lifespan when mutated or overexpressed. There are also several genes known that decrease lifespan when mutated or overexpressed but these are mostly not relevant because they affect viability instead of the normal aging process (Jazwinski, 2001; Hoopes *et al.*, 2002). However, if a mutant strain displays an increase in lifespan, the protein in question is likely, but not necessarily, involved in aging (Sohal *et al.*, 2002). Lifespan extension by overexpression or mutation of genes seems to point to a genetic program in the aging process. But as we discussed earlier, this is not the case. These genes just define the tools with which the yeast cell has to live its life. Better tools, longer life.



**Table 1.2: Proteins involved in yeast longevity**

Name	Description	Lifespan $\Delta$ -strain	Lifespan overexpr.	Ref.
<b>Replicative aging</b>				
Cdc25	Guanine-nucleotide exchange protein for Ras1 and Ras2, has an SH3 domain	47% (cdc25-10)	nd	5
Cyr1	Adenylate cyclase, generates cAMP in response to Ras activation	70%	nd	5
Fob1	Protein required for blocking the replication fork, for recombinational hotspot activity at the HOT1 site in rDNA, and for expansion and contraction of rDNA repeats	67%	nd	10
Gpa2	Guanine nucleotide-binding protein alpha subunit involved in regulation of the cAMP pathway	40%	nd	5
Gpr1	G protein-coupled receptor coupled to Gpa2, involved in the pathway of pseudohyphal differentiation in response to nutrient starvation	41%	nd	5
Hap4	Heme-activated transcription factor; induces respiration	nd	35%	16
Hxk2	Hexokinase2, converts hexoses to hexose phosphates in glycolysis and plays a regulatory role in glucose repression	50%	nd	5
Lag1	Longevity Assurance Gene, involved in ceramide synthesis and ER to Golgi transport	50%	60% -?%	1,2
Lag2	Longevity Assurance Gene, involved in ceramide synthesis and ER to Golgi transport	-50%	20%	2,3
Npt1	Nicotinate phosphoribosyltransferase (NAPRTase), catalyzes the first step in the Preiss-Handler pathway leading to the synthesis of nicotinamide adenine dinucleotide (NAD)	nc	40-60%	5,12
Pnc1	Nicotinamidase involved in nicotinamide to nicotinic acid conversion	nd	70%	13
Ras1	GTP-binding protein involved in regulation of cAMP pathway	19,6	0%	4
Ras2	GTP-binding protein involved in regulation of cAMP pathway	-?%	30%	4
Rpd3	Histone deacetylase required for full repression or full activation of many genes, member of the histone deacetylase family, which catalyze removal of acetyl groups from histones	41%	nd	6
Rtg3	Transcription factor involved in the retrograde response	55%	nd	14
Sip2	Downregulates Snf1 kinase activity by sequestering Snf4	-20%	+?%	15
Sir2	NAD-dependent histone deacetylase of the Sir2 family, involved in maintenance of silencing of HMR, HML, and telomeres, found in two distinct cellular complexes	-50%	30%	7
Sir4	Coiled-coil protein involved in maintenance of silencing of HMR, HML, and telomeres; component of TEL complex	30% (sir4-42)	nd	8
Snf4	Activator of Snf1 which is involved in derepression of glucose repressed genes	20%	nd	15
Tpk1/2	Catalytic subunit of cAMP-dependent protein kinase 2, protein kinase A or PKA	24% (tpk2-63)	nd	5
Uth1	Unknown, required for high temperature growth and recovery from alfa-factor arrest	+?%	nd	8
Uth4	Protein required for high temperature growth, recovery from alpha-factor arrest, post-transcriptional regulation of HO expression, and normal life span of yeast cells	-50%	25%	9
Zds1	Protein that regulates SWE1 and CLN2 transcription, Sir3	37%	nd	11

phosphorylation, rDNA recombination and silencing, and life span, involved in high calcium tolerance and regulation of beta-1,3 glucan biosynthesis

### Chronological aging

Cyr1	Adenylate cyclase, generates cAMP in response to Ras activation	90%	nd	18
Ras2	GTP-binding protein involved in regulation of camp-pathway	100%	nd	17
Sch9	Protein kinase, Akt/PKB homolog	30%	nd	18
Sod1/2	Superoxide dismutase	-?	10-33%	17

\*complete knockout, otherwise mentioned

nd: not determined

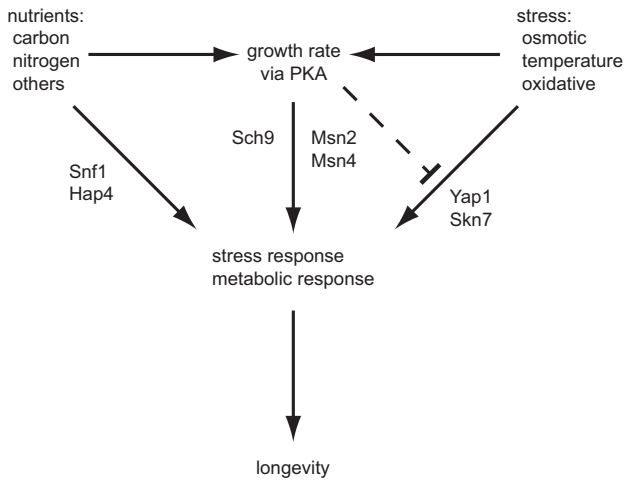
nc: no change

1: (D'Mello *et al.*, 1994), 2: (Sinclair *et al.*, 1998a), 3: (Sinclair *et al.*, 1998b), 4: (Sun *et al.*, 1994), 5: (Lin *et al.*, 2000), 6: (Kim *et al.*, 1999), 7: (Kaeberlein *et al.*, 1999), 8: (Kennedy *et al.*, 1995), 9: (Kaeberlein and Guarente, 2002), 10: (Defossez *et al.*, 1999), 11: (Roy and Runge, 2000), 12: (Anderson *et al.*, 2002), 13: (Anderson *et al.*, 2003), 14: (Jiang *et al.*, 2000), 15: (Lin and Guarente, 2003), 16: (Lin *et al.*, 2002), 17: (Longo, 1999), 18: (Fabrizio *et al.*, 2001)

Not all the data presented in table 1.2 is without controversy. Lag1 for instance shows in the deletion strain as well as in the moderate overexpression experiment an increase in budding lifespan of 50% and 60 % respectively, which is hard to reconcile with each other. However, there are two main themes emerging from this list: nutrient signalling and genetic stability. Genetic stability and its dependence on NAD<sup>+</sup> were discussed earlier but how does nutrient signalling fit in?

### 1.2.8. Regulation of metabolism

That metabolism is involved in aging was already clear from the correlations between the 'rate of living' and lifespan and experiments with caloric restriction. From table 1.2 however it appears that there is more. In higher eukaryotes such as *C. elegans*, *D. melanogaster* and also mice, the insulin pathway was connected to longevity. In *S. cerevisiae* there is no insulin pathway but there are other routes regulating metabolism. It is remarkable that also in *S. cerevisiae* glucose metabolism is regulated with such an enormous precision, just as in higher eukaryotes. One of the main pathways is the Ras/PKA pathway. This pathway seems to be of crucial importance in sensing the environmental conditions. Both the availability of the different essential nutrients but



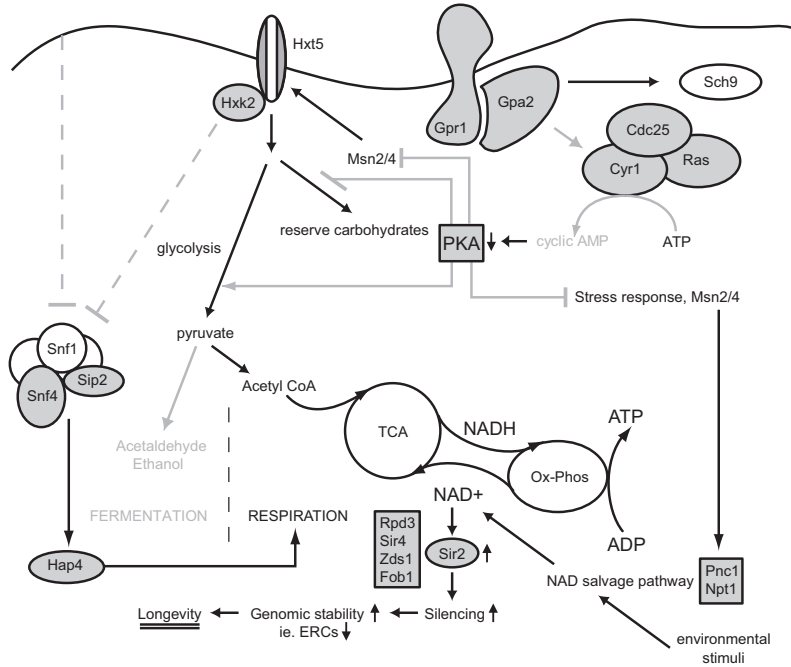
**Figure 1.7:** Growth conditions signalling through PKA.

also the lack of any stressful conditions can positively influence PKA activity (figure 1.7) (Rolland *et al.*, 2002). However it is not completely clear how different stressful environments are sensed by PKA. It is known for instance that Yap1 is involved in transcription activation of SSA1 (Stephen *et al.*, 1995), which codes for a heatshock protein capable of binding to Cdc25 (Geymonat *et al.*, 1998). Cdc25 is a G-protein upstream of PKA and involved together with Ras1 in activating the adenylate cyclase Cyr1. Cyr1 in turn converts ATP into cAMP, which subsequently activates PKA (see figure 1.8). Also upstream of PKA is a G-protein coupled receptor Gpr1 together with Gpa2 taking care of activating Cyr1. Activation of PKA has several consequences i) trehalose and glycogen content decreases, ii) stress response is downregulated, iii) gluconeogenesis is downregulated, iv) glycolysis is upregulated and v) growth is induced (Thevelein and de Winde, 1999). It is remarkable that mutation or overexpression of several components of this system like Ras1, Ras2, Cdc25, Cyr1, Gpa2, Gpr1 and Tpk2 (subunit of PKA) all have effects on the lifespan (table 1.2). This strongly suggests that this pathway can modulate lifespan. In general, the PKA pathway is considered to be a sensor off the nutrient status of the environment. Not only the availability of for instance glucose is taken into account but also essential elements like nitrogen need to be present. PKA is probably able to sense both, because in a nitrogen limited culture, downstream targets of PKA like Hxt5 are only expressed during low growth rates although there is still plenty of glucose present (Verwaal, 2003). Increased temperature is also deactivating PKA, so it is not only an indicator of nutrient availability (Griffioen *et al.*, 2003).

LOW GROWTH RATES  
because either:

low carbon source  
low nitrogen source

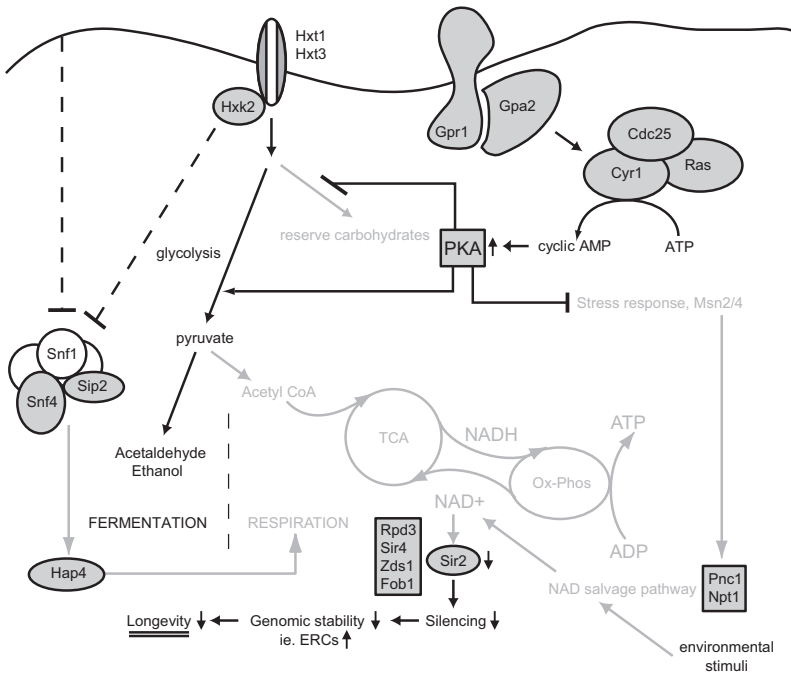
oxidative stress  
osmotic stress  
high temperature



HIGH GROWTH RATES  
because of:

high carbon sources  
high nitrogen sources

no oxidative stress  
no osmotic stress  
normal temperature



**Figure 1.8:** Longevity pathways in *S.cerevisiae* during high and low growth rates. Light grey arrows denote inactive pathways and hatched squares/circles denote proteins from table 1.2. The availability of nutrients leads to the formation of cAMP and subsequent activation of PKA. This leads to a whole range of events, from induction of glycolysis to the repression of stress response including reserve carbohydrate formation. The Ras/PKA pathway is not the only one involved, also the Snf1kinase responds to changes in glucose concentrations although the kinase is activated when glucose levels are low subsequently inducing respiration via Hap4. During respiration NAD<sup>+</sup> flux will increase leading to more active Sir2, which subsequently leads to more silencing and genomic stability. This pathway is also stimulated by the NAD<sup>+</sup> salvage pathway, which is induced by environmental stimuli as low glucose, oxidative stress, heat stress and other low dose stress.

This observation puts the effect of active PKA on the expression of different groups of genes into a broader perspective. PKA is able to downregulate both Skn7, general stress response signal transducers Msn2/Msn4 and possibly also Yap1 (Charizanis *et al.*, 1999; Hasan *et al.*, 2002). This indicates a possible self-regulation loop because as mentioned earlier, Yap1 could be able to regulate PKA activity via Ssa1 and Cdc25.

The earlier described effect of caloric restriction on activation of Sir2 via NAD<sup>+</sup> turnover in the mitochondria can also be caused by the stress activated NAD<sup>+</sup> salvage pathway via PKA activated Pnc1 (figure 1.8). PNC1 is activated by stress conditions including heat, osmotic stress and caloric restriction (Bitterman *et al.*, 2003) and its promoter region has 4 STRE consensus sequences (AGGGG or CCCCT) (van Helden *et al.*, 2000) within the first 350 basepairs, which are the target for transcription activators Msn2 and Msn4 (Martinez-Pastor *et al.*, 1996). The activity of Msn2 and Msn4 is antagonized by PKA (Smith *et al.*, 1998).

The effect on stress response and metabolism is established, although the link with oxygen radicals in this case is not substantiated so far. The opposite effects of the Ras2 deletion during chronological and replicative aging and the behaviour of the Sod1 and Sod2 mutants during chronological aging suggests that being able to invoke a stress response is more important for stationary phase cells than for dividing cells. This fits with the ‘disposable soma’ concept in which limited resources have to be invested in either maintaining soma, in this case stress protection, or in producing offspring.

### 1.2.9. Cell cycle and genetic stability

In *S. cerevisiae*, aging and the cell cycle are highly intertwined processes. As shown before, the length of the cell cycle is mainly determined by the length of the G1-phase (Silljé *et al.*, 1997), which is dependent on the availability of nutrients. Furthermore, the availability of nutrients also regulates longevity as seen with earlier mentioned caloric restriction experiments. When food is scarce, yeast can go into stationary phase thereby halting the cell cycle. The longer this state of seclusion takes, the shorter the subsequent reproductive lifespan will be when food conditions improve again (Ashrafi *et al.*, 1999). One of the phenotypic changes in old cells is that the duration of the cell cycle increases. Not only the duration, also the cell volume increases. Mortimer and Johnston believed that the latter was the reason why yeast cells died. The increase in size would be the cause of logistic problems like getting cellular components from one side to the other. However, this turned out not to be the case, an increase in cell size did not alter lifespan per se (Kennedy *et al.*, 1994). However, other experiments showed that by lowering glucose availability using a fed-batch setup the length of the G1-phase could be altered (Silljé *et al.*, 1997). Although the lifespan was not determined with these cultures, it is reasonable to believe that the imposed slow growth is analogous to caloric restricted cells. Above all it remains clear that nutrient availability is important for both cell cycle duration and lifespan.

In line with earlier mentioned damage caused by oxygen radicals it was suggested that oxidative damage to DNA could be the cause of aging. Daughters derived from old mothers do show a decreased lifespan, but this is restored within a few generations (Kennedy *et al.*, 1994). This observation does not rule in favour of permanent DNA damage. Less permanent protein damage still could do the trick. It appears that ribosomes from old cells are less effective than from young cells. This could mean that translational activity decreases during aging (Motizuki and Tsurugi, 1992). This could also account for the increase in cell cycle duration even if nutrients allow a short G1 phase.

However, why yeast cells at a certain (st)age stop dividing is still unknown. The focus of much research is into the mechanisms of DNA damage checkpoints, or checkpoints sensing replication blocks or spindle defects. These checkpoints are involved in temporarily, or maybe permanently, halting progression through the cell cycle giving the cell some time for repairs.

Evidence for DNA damage under 'physiological' conditions in yeast has remained scarce so far. Much more data is gathered by adding stress agents, like hydrogen peroxide, from the outside. These treatments may have severe effects on the cell architecture and organization, also leading to cell death. It is for instance known that hydrogen peroxide causes cell cycle arrest at the G2 phase of the cell cycle while menadione, a compound that generates superoxide radicals, causes arrest at G1 phase (Flattery-O'Brien and Dawes, 1998). This already occurs at concentrations that are not lethal for the cell. Cell cycle arrest can also be induced by stress agents that cause genomic instability. Methyl Methanesulfonate (MMS) is a DNA damaging agent that induces Gross Chromosomal Rearrangements (GCRs). The GCR to arrest signalling is mediated by different cell cycle checkpoints (Kolodner *et al.*, 2002). It is not surprising that some variability in genetic stability exists during the cell cycle but it is no coincidence that this phenomenon is also associated with aging.

The response to agents like hydrogen peroxide, the superoxide generating drug menadione and other environmental changes has been mapped extensively by Gasch *et al.* using microarray techniques (Gasch *et al.*, 2000). One of the conclusions was that large similarities exist between reactions to different stress conditions. This can also account for the cross-resistance to different stresses, where cells that are 'conditioned' by a low dose of the first stress are better capable of handling a bigger dose of a second and different stress agent.

A few years before, Spellman *et al.* comprehensively surveyed the cell cycle dependent expression of the transcriptome, using different kinds of synchronization methods, like alpha-factor arrest, elutriation and release of a temperature sensitive Cdc15 mutant (Spellman *et al.*, 1998). Genome-wide experiments investigating stress response during the cell cycle have not been published so far.

## 1.3 Scope of this thesis

A clear link exists between metabolism and aging in *Saccharomyces cerevisiae* as shown in the previous paragraphs. Both the effect of caloric restriction on longevity, and the fact that several mutants of genes involved in nutrient signalling display enhanced lifespan, suggest that environmental conditions like the availability of nutrients are of major importance for determining longevity. Not only the availability of nutrients but also other stressful environments are able to elongate lifespan. However, it is still unclear how these environmental cues affect the response of the cell and why this would lead to longevity. To unravel these issues, experiments involving slow growth, synchronous cells, aged cells and stress response were conducted and the results are described in this thesis.

Caloric restriction results in elongation of the lifespan of *S. cerevisiae* and in a decrease in growth rate. The growth rate is mainly determined by the length of the G1-phase. In chapter 2 the mRNA expression profiles of cells progressing slowly and fast through G1 was examined. This revealed that removal of Sir2-inhibitor nicotinamide is probably more efficient during slow growth. This leads to more active Sir2 and increased genetic stability. Besides this response, slow growth conditions also result in an elevated stress response. Several genes of for instance the thioredoxin system increased expression during slow growth. In addition, the synthesis of stress protectant trehalose was induced as well. Genes coding for proteins forming the proteasome exhibit higher expression levels in the slow growing cells as compared to the fast growing cells. This shows that a stress response is triggered during slow growth conditions, which could be involved in facilitating longevity.

To elucidate whether the phase of the cell cycle is important for the regulation of this stress response, microarray experiments were conducted with synchronous cells either exposed to 0.1 mM hydrogen peroxide or not, as described in chapter 3. This revealed that transcriptional control of several genes involved in the thioredoxin system are both stress and cell cycle dependent and especially dedicated to the S-phase.

To verify these results on protein level, a reporter construct was used with a *TRX2* promoter, as described in chapter 4. This showed that although mRNA levels were constantly upregulated during the cell cycle after exposure to hydrogen peroxide, this was not the case for the reporter construct. The reporter construct was only induced



after cells had entered S-phase. This was explained by a reduced protein synthesizing capacity during the early G1.

To determine how stress response is affected in aged yeast, experiments were conducted with aged yeast cells obtained via continuous elutriation. At least 50 % of this population had on average 7 budscars. These cells were exposed to 0.1 mM hydrogen peroxide and their mRNA expression profiles were compared to that of young cells. This led to the assumption that aged cells are less capable to respond to oxidative stress, which is described in chapter 5.

In chapter 6 the earlier described reporterconstruct with *TRX2* promoter was used to devise a medium scale screeningsystem for potential new antioxidants able to reinforce oxidative stress defences.

In chapter 7 these results are discussed in a broader perspective coupling aging, slow growth conditions and stress response to each other.



2

*S*low growing *Saccharomyces cerevisiae* show increased expression levels of genes involved in oxidative stress protection and of structural subunits of the proteasome

## Abstract

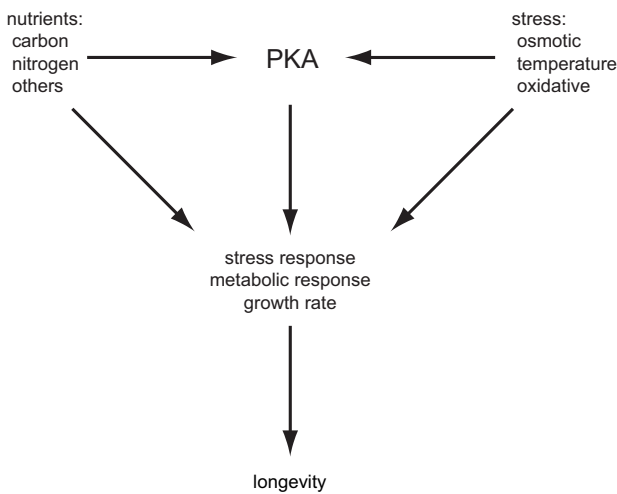
Microarray experiments and analysis were carried out to investigate the gene expression profiles in slow and fast growing cells during G1-phase. Slow growth was imposed by using a fed-batch setup, which enables control of environmental conditions in contrast to normal batch growth. Several functional groups of genes were found to be differentially regulated under the slow and fast growth conditions. The slow growth was induced by limiting the access to the carbon sources, in this way not only reducing growth rate but also obtaining caloric restricted cells.

*PNC1*, a gene involved in the  $\text{NAD}^+$  salvage pathway was found to be expressed at higher levels during slow growth conditions, in this way able to remove nicotinamide, which is a Sir2 inhibitor. Sir2 is deacetylating histones to prevent genetic instability. An increase in stress response was found to occur in the slow growing cells. Genes involved in an oxidative stress response (thioredoxins, glutaredoxins, glutathione, superoxide dismutases and catalase), proteasome (structural subunits) and the accumulation of reserve carbohydrates (trehalose synthases amongst others) also showed relative high expression levels during slow growth conditions. These responses could be mediated by the PKA pathway as sensor and transmitter of environmental conditions. These results reveal a cell determined to survive by anticipating on future challenges.

## Introduction

Caloric restriction is a phenomenon only recently observed to occur in *Saccharomyces cerevisiae* (Jiang *et al.*, 2000; Lin *et al.*, 2000). Cells grown in the presence of 2 % glucose or 0,5 % glucose showed differences in replicative lifespan (Lin *et al.*, 2000). Remarkable is that limiting nitrogen sources, while maintaining high glucose levels, also induced a lifespan extension (Jiang *et al.*, 2000). This last observation indicates that induction of longevity is not induced by caloric restriction alone. It turns out that also elevated temperature and osmotic stress are able to induce longevity (Shama *et al.*, 1998; Swiecilo *et al.*, 2000). Besides this effect on lifespan these conditions all have in common that the growth rate is diminished (Verwaal *et al.*, 2002). Whether this decrease in growth rate is one of the by-products of caloric restriction or that it is a requirement for extending lifespan remains to be seen. Fact is, that in *Saccharomyces cerevisiae* it is rather easy to manipulate growth rate using a fed-batch setup (Silljé *et al.*, 1997). In this setup, carbon sources are gradually added to a growing cell culture by using a pump. It was shown that the duration of the cell cycle is mainly dependent on the time spent in G1 (Carter and Jagadish, 1978). The effect of caloric restriction induced slow growth on longevity suggests that changes in cellular behaviour probably already occur at the start of the yeasts' life cycle. Comparing virgin daughter cells progressing fast through G1 with cells progressing more slowly will reveal processes involved in longevity. This experimental setup has major advantages over common culture conditions used. Research described by Kaeberlein *et al.* showed that varying extracellular glucose concentrations has major influences on lifespan (Kaeberlein *et al.*, 2002). During normal batch growth, carbon source concentrations vary rapidly, obscuring lifespan analysis. Also in the micromanipulation experiments in which yeast cells are grown on agar plates, which are transferred to cold rooms to be able to keep track of the amount of daughter cells (Shama *et al.*, 1998), errors can be introduced by the cold shock that have effect on lifespan.

The PKA pathway seems to fulfil an important role in regulating growth rate as a sensor and subsequent transmitter of environmental conditions (figure 2.1) (Thevelein and de Winde, 1999; Verwaal, 2003). Furthermore, the PKA pathway plays a role in longevity as is revealed by mutation or overexpression of several genes from the PKA pathway leading to lifespan elongation, as listed in table 1.2 (Bitterman *et al.*, 2003). In



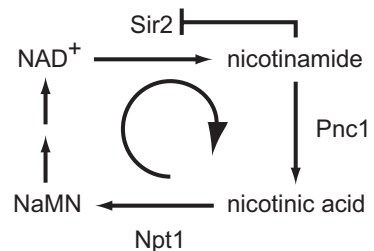
**Figure 2.1:** PKA as a central regulator in environmental responses and subsequent longevity.

addition to genes involved in nutrient signalling, also multiple genes from this list are involved in maintaining genetic stability in which  $\text{NAD}^+$  seems to play an important role (Lin *et al.*, 2000).  $\text{NAD}^+$  is a cofactor for histone deacetylase Sir2 and in this way involved in activation of Sir2 and subsequently in the degree of acetylation of histones

(Landry *et al.*, 2000). This is important for stabilising the chromosomes particularly the ribosomal DNA locus, the telomeres and the mating locus (Roy and Runge, 2000). Especially the formation of extrachromosomal ribosomal circles (ERC's) by homologous recombination is diminished by more active Sir2. These circles are detrimental to the cell because they exponentially accumulate eventually messing up replication logistics (Sinclair and Guarente, 1997).

Both genetic instability and nutrient signalling via the PKA pathway are involved in lifespan determination. How does caloric restriction fit into these two processes? Although previously the effect of caloric restriction on lifespan in mammals was usually attributed to a decrease in metabolism associated radical formation, it turned out that at least in yeast other mechanisms are contributing as well.

Changes in metabolism, for instance by limiting the supply of sugars (caloric restriction) leads to changes in  $\text{NAD}^+$  levels or flux, subsequently leading to changes in genetic stability and changes in lifespan. However, measured  $\text{NAD}^+$  concentrations were not influenced, which partly undermines these assumptions (Anderson *et al.*, 2002).  $\text{NAD}^+$  is synthesized via eight intermediates from tryptophan or can be synthesized from nicotinic acid taken up from the medium. However it can also be recycled via the  $\text{NAD}^+$  salvage pathway (figure 2.2). This recycling pathway is essential



**Figure 2.2:** The  $\text{NAD}^+$  salvage pathway

for regulating  $\text{NAD}^+$  and nicotinamide levels (Bitterman *et al.*, 2003). Nicotinamide is a by-product of the Sir2 reaction and has an inhibiting effect on the activity of Sir2 (Anderson *et al.*, 2003). This explains why overexpression of the gene involved in metabolising nicotinamide to nicotinic acid, *PNC1*, leads to a major increase in lifespan (Anderson *et al.*, 2003). This gene is of crucial importance for the activity of Sir2. However in a  $\Delta\text{sir2}$  deletion strain, it is still possible to induce caloric restriction, (Jiang *et al.*, 2002) although Lin *et al.* did not find this (Lin *et al.*, 2002). This means that Sir2 is not the only  $\text{NAD}^+$  dependent histone deacetylase and that there is functional redundancy or that  $\text{NAD}^+$  dependent genetic stability is not the only aspect involved in caloric restriction. This redundancy is exemplified by the existence of at least two other known  $\text{NAD}^+$  dependent histone deacetylases (Hst1 and Hst2) and two putative ones (Hst3 and Hst4).

Yeast cells exposed to extreme high levels of glucose (10 %) show an increase in lifespan (Kaeberlein *et al.*, 2002). This was explained by pointing out that these high concentrations of glucose lead to an osmotic stress response, which involves glycerol synthesis as an osmoprotectant. This glycerol synthesis has as by-product  $\text{NAD}^+$  so again Sir2 activity is affected. However, exposing cells to high osmolarity also leads to a stress response, a decrease in growth rate and a decrease in PKA activity (Norbeck and Blomberg, 2000), which is influencing lifespan as discussed above.

Apparently, caloric restriction is only one of several treatments leading to lifespan extension in yeast, all having in common that growth rate is decreased and PKA activity is lowered. PKA is involved in several other processes like stimulating growth and glycolysis. In addition it is a negative regulator for general stress response, gluconeogenesis and reserve carbohydrate accumulation (Thevelein and de Winde, 1999). Two of the transcriptional activators that are negatively regulated by PKA, are Msn2 and Msn4 (Smith *et al.*, 1998). These two proteins initiate the expression of several genes by binding to STRE consensus sequences in their promoter region (Martinez-Pastor *et al.*, 1996).

In the described experiments, a fed-batch setup with low amounts of carbon sources (20 fmol galactose /cell/hour) was used to obtain slow growing yeast in a constant environment. These samples were compared to cells growing in high galactose (1 %) as control. This revealed that there are several oxidative stress proteins like *TRX1*, *TRX2*, *TSA1*, *AHP1*, *PRX1*, *GRX1*, *TTR1*, *HYR1*, *SOD1*, *SOD2*, *CTA1* upregulated during the slow growth samples. This means that more radicals, probably from

respiration, are roaming through the cell and they have to be dealt with. Besides these stress proteins, also the synthesis of stress-protectant trehalose and half of the proteasomal core subunits showed higher expression under slow growth conditions. Damage to proteins, either by oxygen radicals, ethanol or others, gives need to higher protein turnover. The upregulation of *PNCI* showed that removal of nicotinamide during slow growth conditions is probably more efficient than during fast growth. These data show that stress response and  $\text{NAD}^+$  metabolism are important processes for maintaining vigour during slow growth conditions.



## Materials and methods

### Strains and growth conditions:

In all experiments the wildtype strain CEN-PK113-7D (*MATa SUC2 MAL2-8c MEL*) also known as VWk43 was used. Cultures were grown at 30°C in a rotary shaker at 180 rpm in Yeast Nitrogen Based medium w/o amino acids (YNB, Difco, Detroit, USA) with galactose as carbon source.

### Centrifugal elutriation:

Synchronous cells were obtained by centrifugal elutriation as described by Silljé et al. (Silljé *et al.*, 1997). Cells were grown in 1 litre of YNB with 1 % galactose at 30°C until they reached an OD600 of 2.0. The cells were harvested in a centrifuge at room temperature and sonicated twice for 20 seconds to disturb cell clumps while kept on ice. They were loaded into an elutriator spinning at 2000 rpm (Beckman J-6 MI, Mijdrecht, Beckman Coulter Netherlands) with a 40 ml chamber kept at 30°C. Using a Masterflex pump from Cole-Parmer (Aplikon, Schiedam, Netherlands) YNB medium containing 1 % galactose was pumped into the chamber, washing away the newly formed daughter cells, which were subsequently collected on ice. After centrifuging, cells were kept overnight in YNB 1 % galactose on ice. After refreshing the medium, the cells were followed during the cell cycle by monitoring their budding percentages. At least 100 cells per timepoint were counted.

### Fed-batch setup:

Synchronous cells were centrifuged and resuspended in YNB without amino acids and without carbon sources. By using a pump small amounts of galactose (20 fmol/cell/hour) were dropwise administered to this culture while kept in a rotary shaker (Silljé *et al.*, 1997).

### mRNA isolation:

mRNA was isolated using a phenol/chloroform extraction as described in Maniatis (Sambrook *et al.*, 1989) with modifications. Samples of 10 ml were quickly frozen by immersion in liquid nitrogen. After slowly thawing the cells and washing them with 1 ml extraction buffer (100 mM Tris-HCl (pH 7.5), 100 mM LiCl, 10 mM EDTA), cells were resuspended in 0.5 ml vortex buffer (100 mM LiCl, 10 mM EDTA,

0.5 % LithiumDodecylsulphate, pH 7.5 with LiOH). Vigorous shaking with 0.45 mm glass beads in a bead-beater (Biospec products, Bartlesville, OK, USA) disrupted cell walls and membranes after which a phenol chloroform extraction was performed. After addition of 50 µl 3M NaAc and 1.25 ml ice-cold ethanol, the mRNA was precipitated at -80°C, samples were centrifuged, washed with cold ethanol (70 %), air-dried and resuspended in water.

### **Microarray experiments:**

Microarray experiments were conducted as described by Schoondermark-Stolk et al. (Schoondermark-Stolk *et al.*, 2002). Isolated pools of transcripts were labeled with radioactive dCTP. Making cDNA from the isolated mRNA in the presence of radioactively labelled nucleotides performs this labelling. 4 µg of RNA (measured at 260 nm) was mixed with 2 µl of OligodT (1 µg/µl), to a final volume of 10 µl. The following components were added: 6 µl of first strand buffer (Life Technologies, Breda, The Netherlands), 1 µl of 0.1 M dithiothreitol, 1.5 µl of a mixed solution containing 100 mM of dATP, dGTP and dTTP, 300 units of Superscript II reverse transcriptase (Life Technologies) and 100 µCi [<sup>33</sup>P]CTP (Amersham Biosciences, Roosendaal, The Netherlands). The mixture was kept at 37°C for 90 min. after which 70 µl of STE (0.1 M NaCl, 10 mM TRIS.HCL (pH 8.0), 1 mM EDTA) was added. The newly synthesized cDNA was then purified by passage through a Sephadex G-50 column (Amersham Biosciences) and washed with 350 µl of STE after which it was eluted with 500 µl of STE. The cDNA was denatured by heating it to 100°C for 3 min.

Yeast GeneFilter microarrays (ResGen, Invitrogen, Breda, The Netherlands) were washed for 5 min. with boiling 0.5 % SDS. The membranes were prehybridized for 4 h with 5 ml MicroHyb solution (ResGen) and 5 µl OligodA (ResGen) at 42°C in a roller oven (Thermo Hybaid, Landgraaf, The Netherlands). The labelled cDNA probes were added to these prehybridized filters and incubated over night at 42°C. The next day, the filters were rinsed with 2xSSC (diluted from 20xSSC which contains: 3 M NaCl, and 0.3 M Na-citrate, pH 7.0) and 1 % SDS for 20 minutes at 50°C. This was repeated once, after which an additional rinsing step followed with 0.5xSSC with 1 % SDS for 15 minutes at room temperature. The filters were then transferred to a humid 3-layer Whatman filter, wrapped in Saran foil and placed against a Phosphor screen (Molecular Dynamics, Sunnyvale, CA, USA). After 6 days of exposure the screen was read by a phosphorimager SI (Molecular Dynamics) coupled to a computer. The samples with

42

hydrogen peroxide were hybridized twice to different microarray filters and the samples without hydrogen peroxide once.

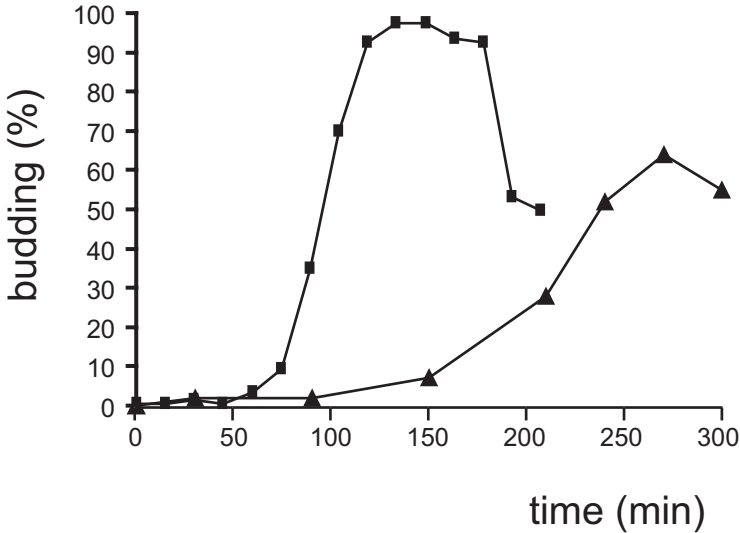
**Data analysis and spot validation:**

Images were scanned at 50- $\mu$ m resolution in Image-Quant 5.1 (Molecular Dynamics) and then imported into the ImaGene 4.2 microarray analysis software (BioDiscovery, Marina del Rey, CA, USA). Standard grids were placed over the images of the arrays after which spotsize was fixed at 15 pixels and the ‘autoadjust spot’ function was applied, which corrects for slight deviations of the grid. Very intense spots tend to ‘blossom’ out their signal, leading to an increase of signal in surrounding spots. Usually these surrounding spots were ‘flagged’ by hand. Flagged data were not used. Although ImaGene has various features to quantify background and signal intensities per spot, it was preferred to use local blank spots as background values except when these spots were flagged. In this case the local blank spot of one row ahead was used. All the quantified data were imported into an Excel sheet (Microsoft) after which the identities of the different genes were added. Values used were the signal mean values, which are the total signal values divided by the area. Normalization was usually carried out by dividing through metacolumn average values.

## Results

### Budding profile shows entry of cells into S-phase is later with carbon-restricted cells in fed-batch setup

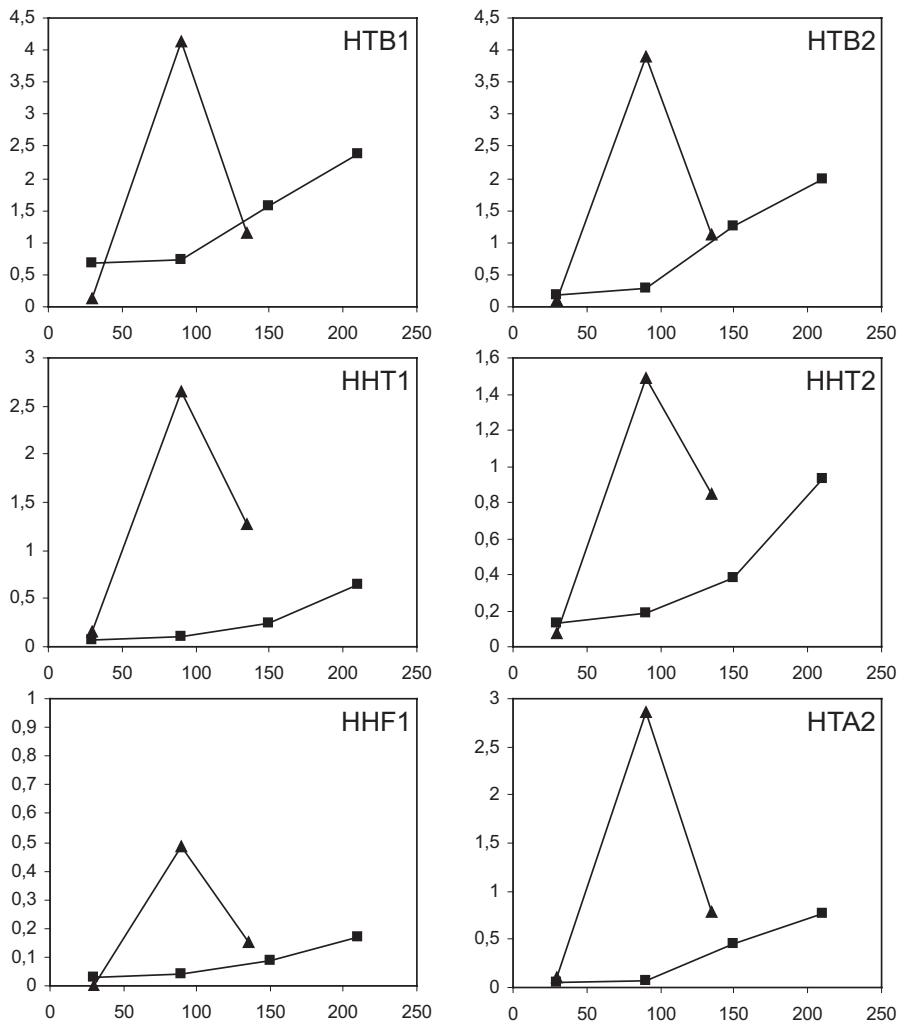
To be able to compare the transcription profiles of caloric restricted cells and cells growing in an environment with abundant nutrients a fed-batch system was chosen to carefully administer galactose to the cells. To monitor whether this indeed led to a slowing down of the cell cycle and an elongation of the G1-phase budding profiles were established. As shown in figure 2.3, cells growing in the presence of 1% galactose proceed much faster through the cell cycle as the cells that are fed galactose by the fed-batch system at a rate of 20 fmol/cell/hour. The maximal budding of around 95% in the fast growing cells is reached after approximately 135 min., while the maximal budding of the slow growing cells is after approximately 270 min. (figure 2.3). The G1-phase in the fast growing cells therefore takes more or less 100 minutes, while during the slow growth this is elongated to 210 minutes. This clearly shows synchronous cells proceeding slowly and fast through the cell cycle.



**Figure 2.3:** Budding percentages show an increase the duration of the G1-phase for cells growing in the fed-batch system with 20 fmol/cell/hour (▲) compared to cells growing on 1% galactose (■).

## Analysis of cell cycle dependent transcripts

To validate whether the obtained microarray data is in line with described literature results several known cell cycle dependent transcripts were examined. The synthesis of histones for instance is primarily taking place during S-phase (Moll and Wintersberger, 1976). As shown in figure 2.4 expression of 6 of the 8 different histone



**Figure 2.4:** 6 of the 8 histone subunits show a delay in their expression during slow growth (■) compared to the fast growing cells (▲). The x-axis shows time in minutes and the y-axis corresponds to relative expression levels (au).

subunits in the fast growing cells, have peak expression around 90 minutes while in the slow growing cells maximal expression is reached at 210 minutes or even later. Other

cell cycle specific transcripts like the expression of the cyclins *CLN1*, *CLN2*, *CLB1* and *CLB6* show peak expression earlier during fast growth than during slow growth (not shown). This illustrates that the microarray results fit with literature data and that growth rate can be manipulated by the fed-batch setup.

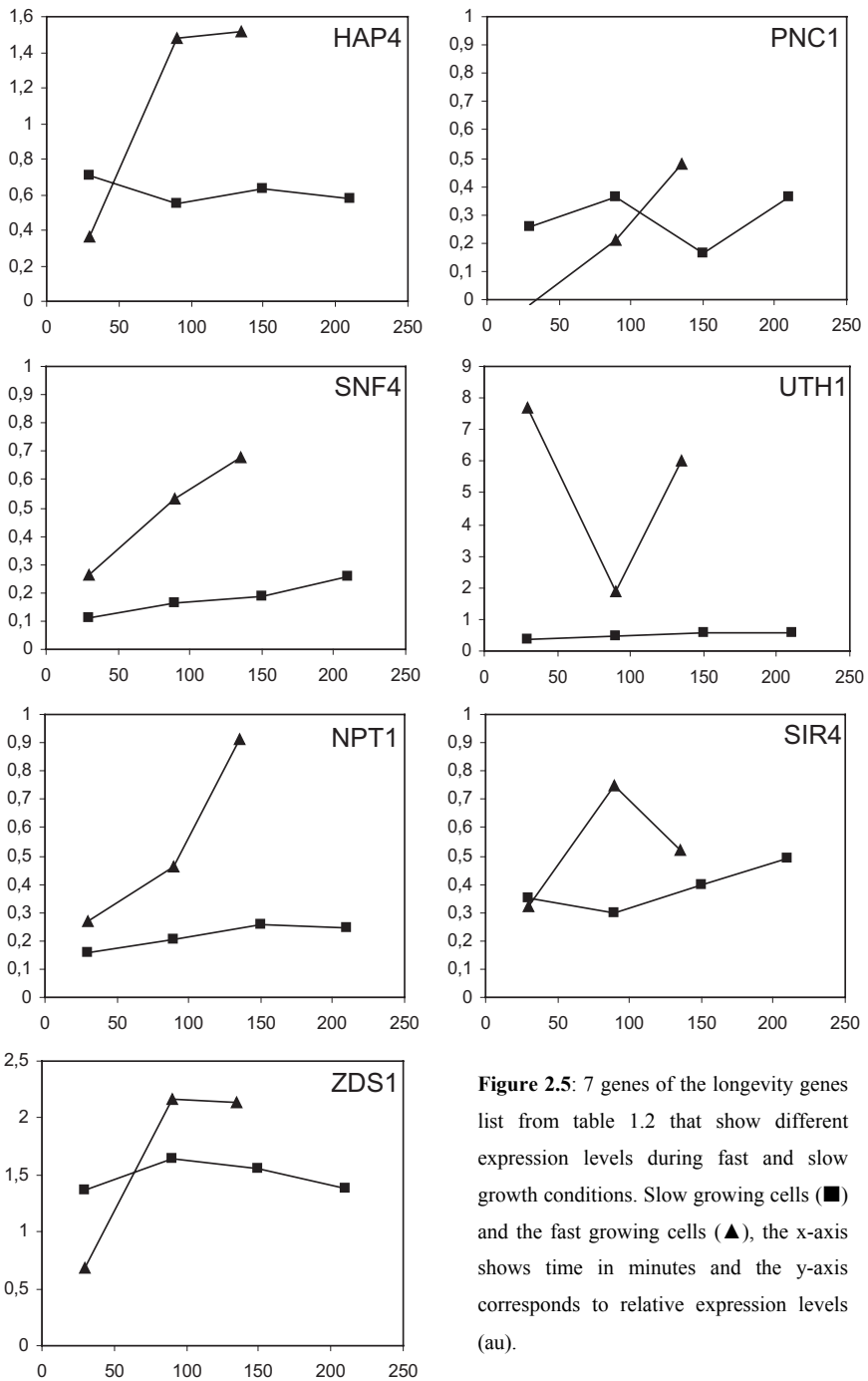
### **Effect of slow growth on the expression of longevity genes**

Several genes are known for elongating lifespan by their deletion or overexpression (see table 1.2). To investigate whether these genes are induced in young cells upon slow growth conditions, microarray experiments were conducted. Of the 24 genes only 7 show differences in expression between the slow and fast growing cells. For instance the *HAP4* gene, which codes for a transcription factor involved in activation of respiration. This gene is expressed at higher levels during fast growth apart from the first timepoint (figure 2.5) possibly because the gene is induced by ethanol (Forsburg and Guarente, 1989), produced during fermentation of galactose. The increase of *HAP4* expression during the fast growth does not fit completely with the data concerning overexpression of *HAP4*, which increases the lifespan of exponentially growing cells.

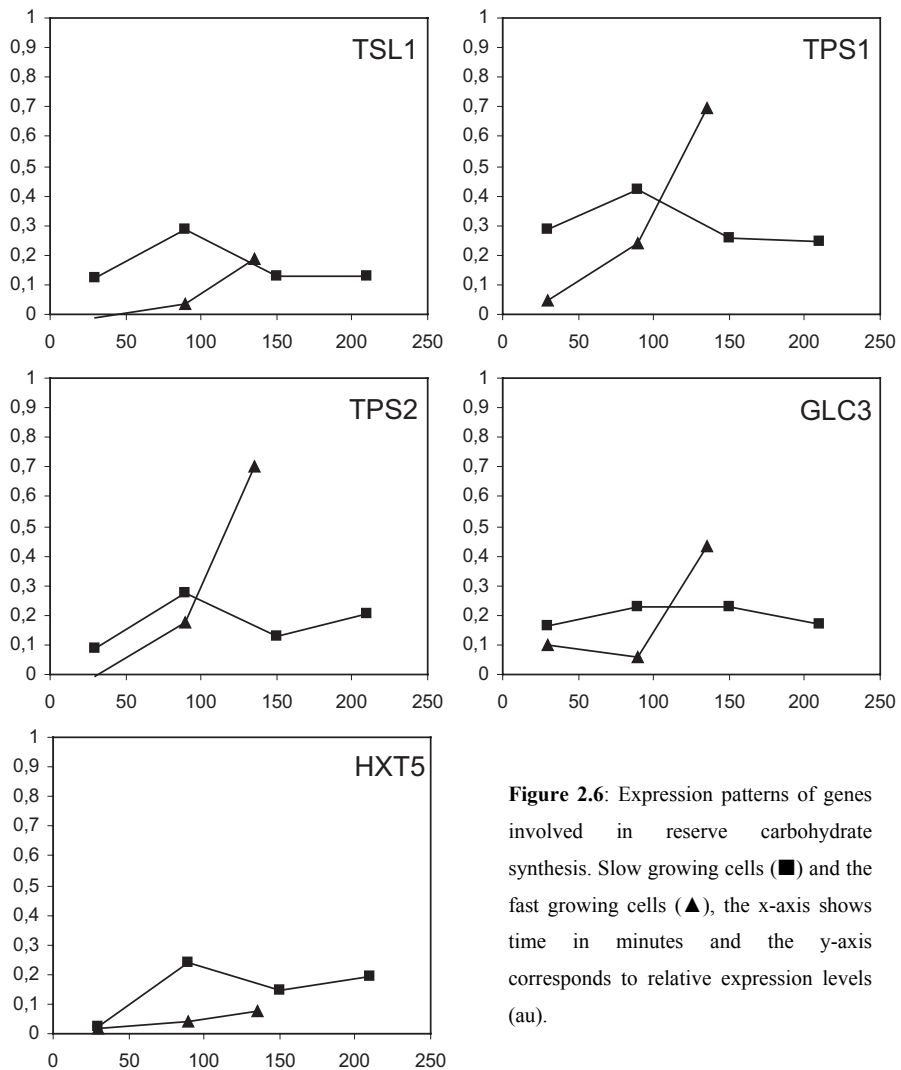
The *PNC1* gene, involved in the NAD<sup>+</sup> salvage pathway (figure 2.2), is higher in the slow growing cells during G1 (see figure 2.5), which fits also its lifespan-extension effect when overexpressed. With nicotinamide as an inhibitor of Sir2 activity, it is not surprising that this enzyme is higher induced during slow growth. This is not observed for the other important gene involved in the NAD<sup>+</sup> salvage pathway, *NPT1* (see figure 2.5). But then again, this gene is not directly involved in either NAD<sup>+</sup> synthesis or in nicotinamide breakdown.

With *SNF4*, *UTH1*, *ZDS1* and *SIR4* the observed patterns are less clear. Their levels are mostly higher in the fast growing cells, in accordance with the observation that deleting these genes leads to lifespan extension.

The known 'longevity' genes from table 1.2 mostly don't show a response after changing environmental conditions. However, activity is not always dependent on the transcription, also translation, localization or posttranslational modifications can be necessary to achieve full activation. Several genes from table 1.2 are involved in the PKA pathway, so it is worthwhile to investigate the expression of some downstream targets of PKA.



**Figure 2.5:** 7 genes of the longevity genes list from table 1.2 that show different expression levels during fast and slow growth conditions. Slow growing cells (■) and the fast growing cells (▲), the x-axis shows time in minutes and the y-axis corresponds to relative expression levels (au).



**Figure 2.6:** Expression patterns of genes involved in reserve carbohydrate synthesis. Slow growing cells (■) and the fast growing cells (▲), the x-axis shows time in minutes and the y-axis corresponds to relative expression levels (au).

### Reserve carbohydrates accumulate during slow growth while glycolysis is reduced

An active PKA pathway is responsible for breakdown of reserve carbohydrates while an inactive PKA pathway induces accumulation of trehalose and glycogen (Smith *et al.*, 1998). It is expected that deactivation of PKA during caloric restriction will lead to derepression of genes involved in stress response and reserve carbohydrate accumulation. Therefore genes involved in these processes were examined.

Low expression of trehalose synthase genes *TPS1*, *TSL1* and *TPS2* during G1 of the fast growing cells (30 and 90 minutes) suggesting that PKA is active (figure 2.6).



On the other hand, during slow growth, these transcripts are expressed at a higher level suggesting a less active PKA pathway. This is confirmed by one of the hexose transporters previously associated to trehalose synthesis, *HXT5*. This gene displays higher expression levels during slow growth (figure 2.6)

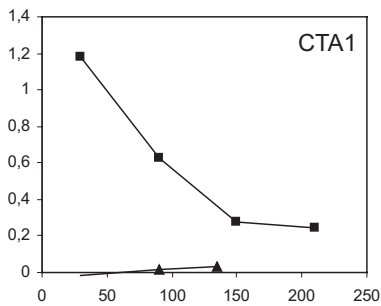
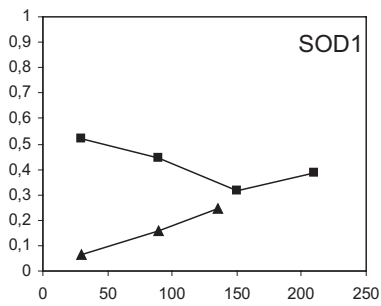
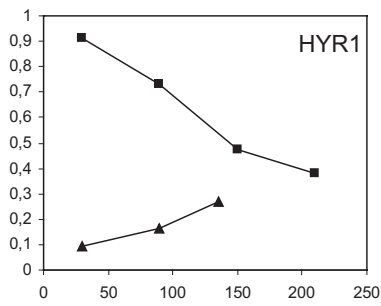
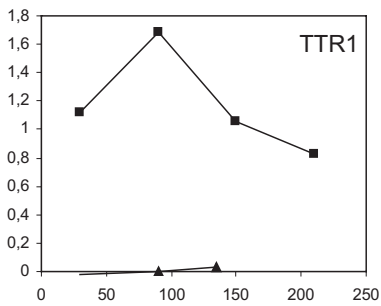
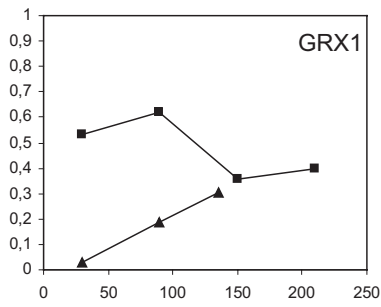
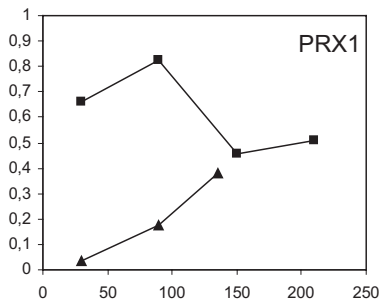
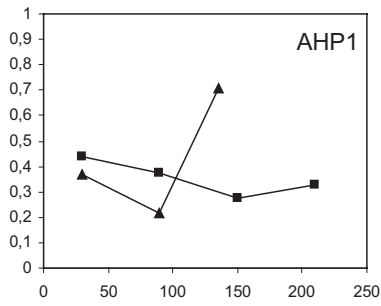
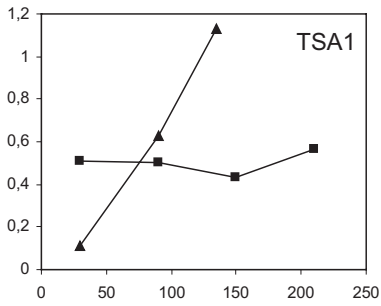
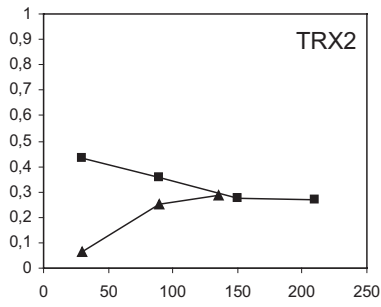
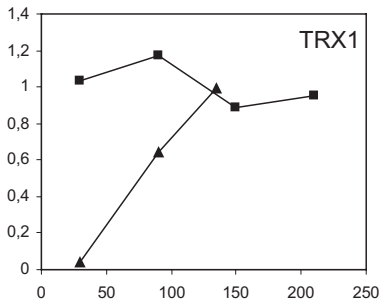
The main glycogen synthases, *GLC3*, shows low expression during fast and higher expression during slow growth conditions. The synthesis of glycogen and trehalose leaves less sugar available for glycolysis illustrated by a decrease in expression of several genes involved in this process during slow growth like *ENO1*, *ENO2*, *GPM1*, *TDH2*, *FBA1*, *PFK1*, *PGK1* and *PGII*. The glycolysis being a target of PKA (Thevelein and de Winde, 1999) this hints again to a less active PKA during the slow growth. During slow growth a considerable amount of the consumed carbon sources goes into accumulation of reserve carbohydrates while during fast growth this is shifted towards the glycolysis.

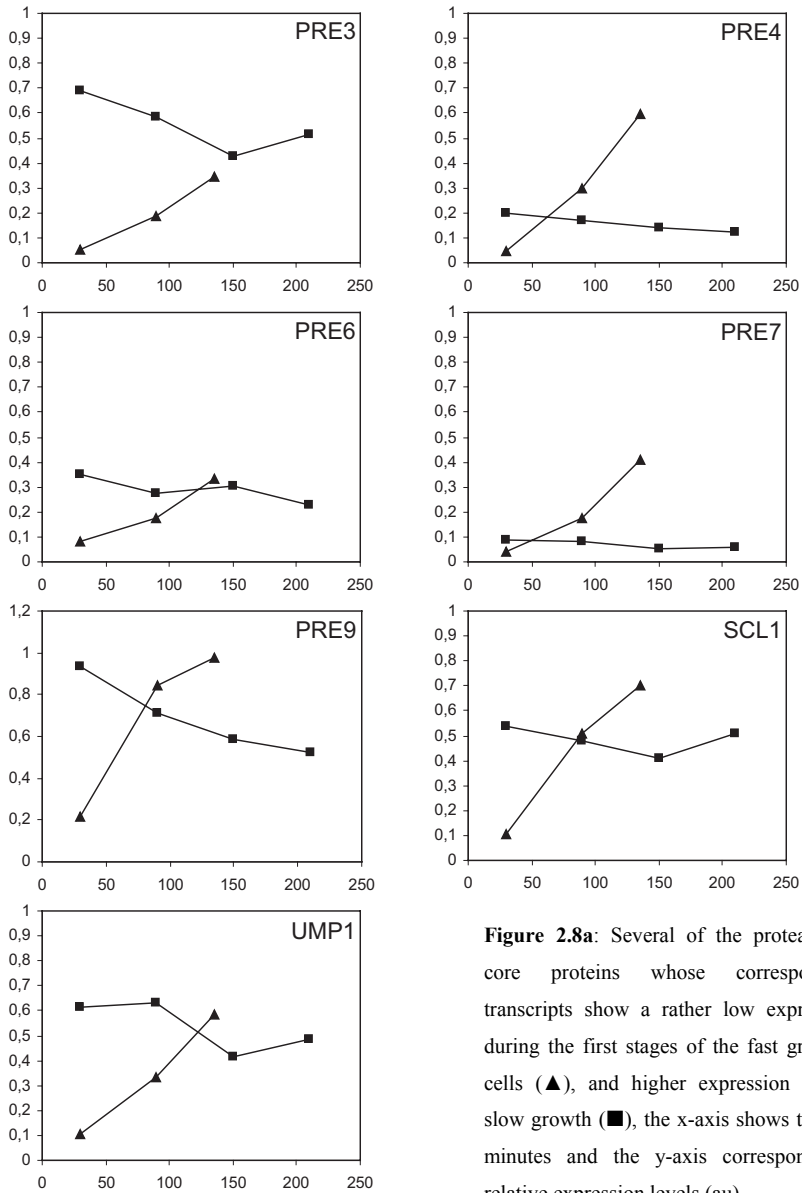
### **Oxidative stress response is partly increased during slow growth**

Trehalose is an important stress protectant and apparently needed during slow growth conditions. To establish whether an oxidative stress response is induced during slow growth, the genes involved in this response were examined as well. Although there are very specific oxidative stress response signal transduction routes via for instance Yap1, PKA is also involved in this response. Several transcripts of different stress resistance systems are expressed at higher levels during the G1 of the slow growth than during fast, like the genes involved in the thioredoxin system: *TRX1*, *TRX2*, *TSA1*, *AHP1*, *PRX1*, glutaredoxins: *GRX1*, *TTR1*, glutathione, *HYR1* superoxide dismutases: *SOD1*, *SOD2* and catalase: *CTA1* (figure 2.7). Not all genes involved in oxidative stress resistance show this behaviour, *TRR1*, *GSH1* and *GSH2* for instance show higher expression levels during fast growth but it looks like they are a minority. These data indicate the existence of an increased stress response during slow growth conditions.

### **Proteasome subunit transcripts are higher expressed during slow growth**

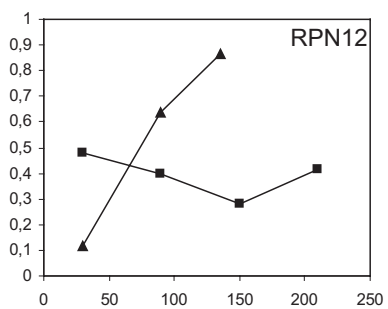
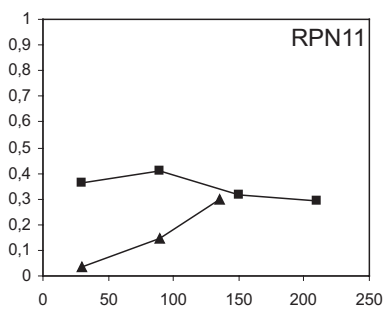
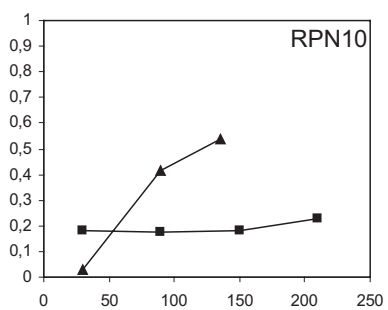
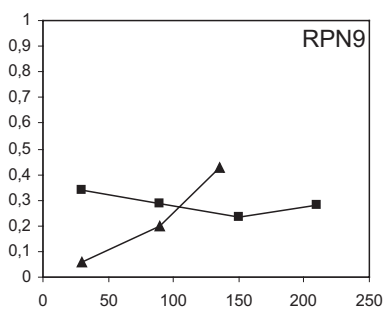
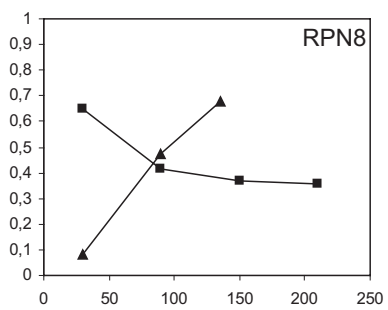
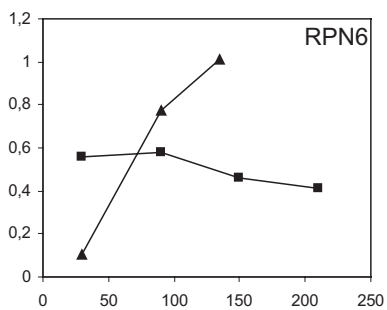
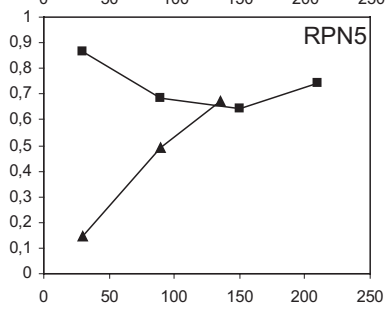
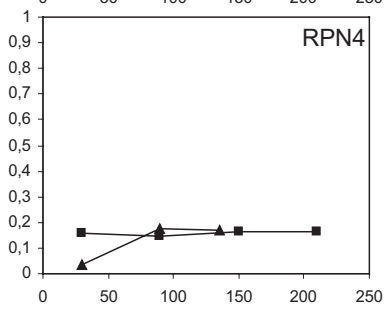
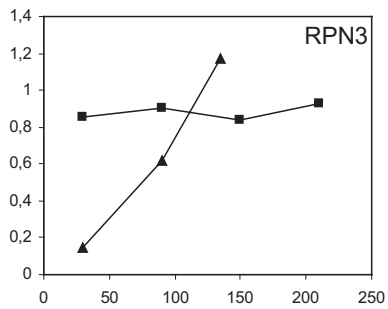
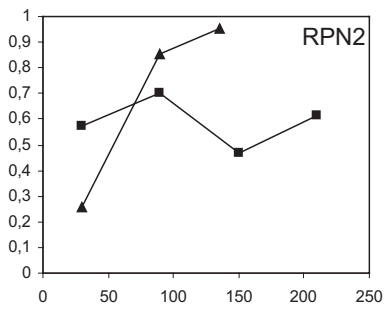
Higher levels of oxidative stress during slow growth could result in more protein damage, which in turn would lead to higher protein turnover by the proteasome. It was investigated if the proteasomal subunits show increased levels of expression during slow growth.

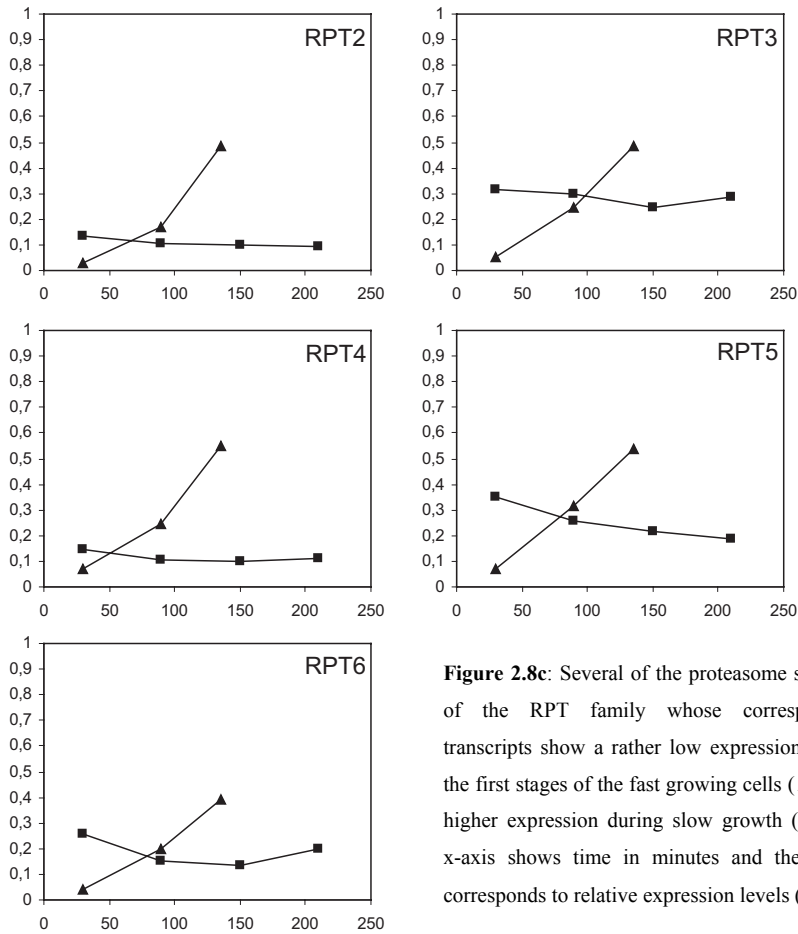




**Figure 2.8a:** Several of the proteasomal core proteins whose corresponding transcripts show a rather low expression during the first stages of the fast growing cells (▲), and higher expression during slow growth (■), the x-axis shows time in minutes and the y-axis corresponds to relative expression levels (au).

**Figure 2.7 (previous page):** Expression patterns of several genes involved in oxidative stress protection that show low expression during fast growth (▲) and higher expression during slow growth (■), the x-axis shows time in minutes and the y-axis corresponds to relative expression levels (au).





**Figure 2.8c:** Several of the proteasome subunits of the RPT family whose corresponding transcripts show a rather low expression during the first stages of the fast growing cells (▲), and higher expression during slow growth (■), the x-axis shows time in minutes and the y-axis corresponds to relative expression levels (au).

**Figure 2.8b (previous page):** Several of the proteasome subunits of the RPN family whose corresponding transcripts show a rather low expression during the first stages of the fast growing cells (▲), and higher expression during slow growth (■), the x-axis shows time in minutes and the y-axis corresponds to relative expression levels (au).

The core of the yeast proteasome consists of 16 proteins (*PRE1*, *PRE2*, *PRE3*, *PRE4*, *PRE5*, *PRE6*, *PRE7*, *PRE8*, *PRE9*, *PRE10*, *PRS3*, *PUP1*, *PUP2*, *PUP3*, *SCL1* and *UMPI*), of which 8 were expressed at rather low levels. The remaining genes all show an expression pattern that features lower expression during the first stage of the fast growth compared to the slow growing cells apart from the *PRS3* transcript (see figure 2.8a). Besides these genes, many more are involved in forming the proteasome, like the *RPN1-13* and *RPT1-6* genes. These families also often (15 out of 19) show low expression during the first stages of the fast growth and higher levels in the slow growth

samples (see figure 2.8b-c). These results indicate more proteasomes in slow growing cells.

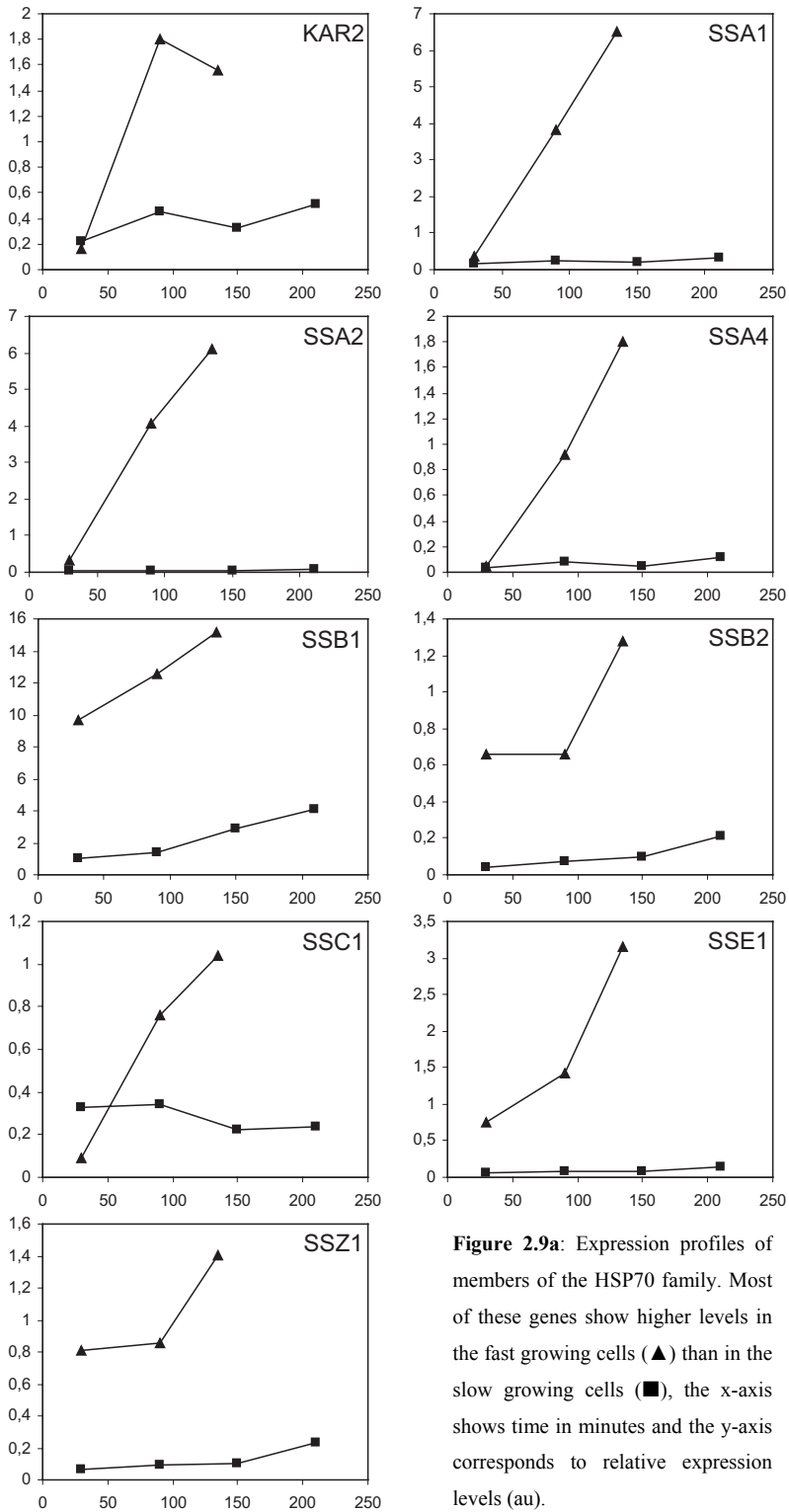
### **HSP70 chaperones show higher levels during fast growth while other chaperones show less clear responses**

Besides an effect on the proteasome, usually chaperones are upregulated to refold denatured proteins. The yeast cells contains various chaperones and chaperone systems. One group of genes is the HSP70 family involved refolding denatured proteins and preventing the formation of aggregates. The expression of these transcripts is higher in fast growing cells (*KAR2*, *SSA1*, *SSA2*, *SSA4*, *SSB1*, *SSB2*, *SSC1*, *SSE1*, *SSZ1*). Also some of the genes coding for CCT chaperones are expressed at higher levels in fast growing cells (*CCT2*, *CCT4*, *CCT5*, *CCT6*, *CCT7*, *CCT8*, *TCPI1*), although this is not as clear as the HSP70 family. Other chaperones show different behaviour (*HSP12*, *HSP26*, *HSP42*, *HSP78*, *HSP82*, *HSP104*, *HSP150*), although these could be involved in ethanol resistance. These results indicate no more protein misfolding during slow growth than during fast growth, while at the same time, as shown in the previous paragraph, the proteasome is higher expressed.

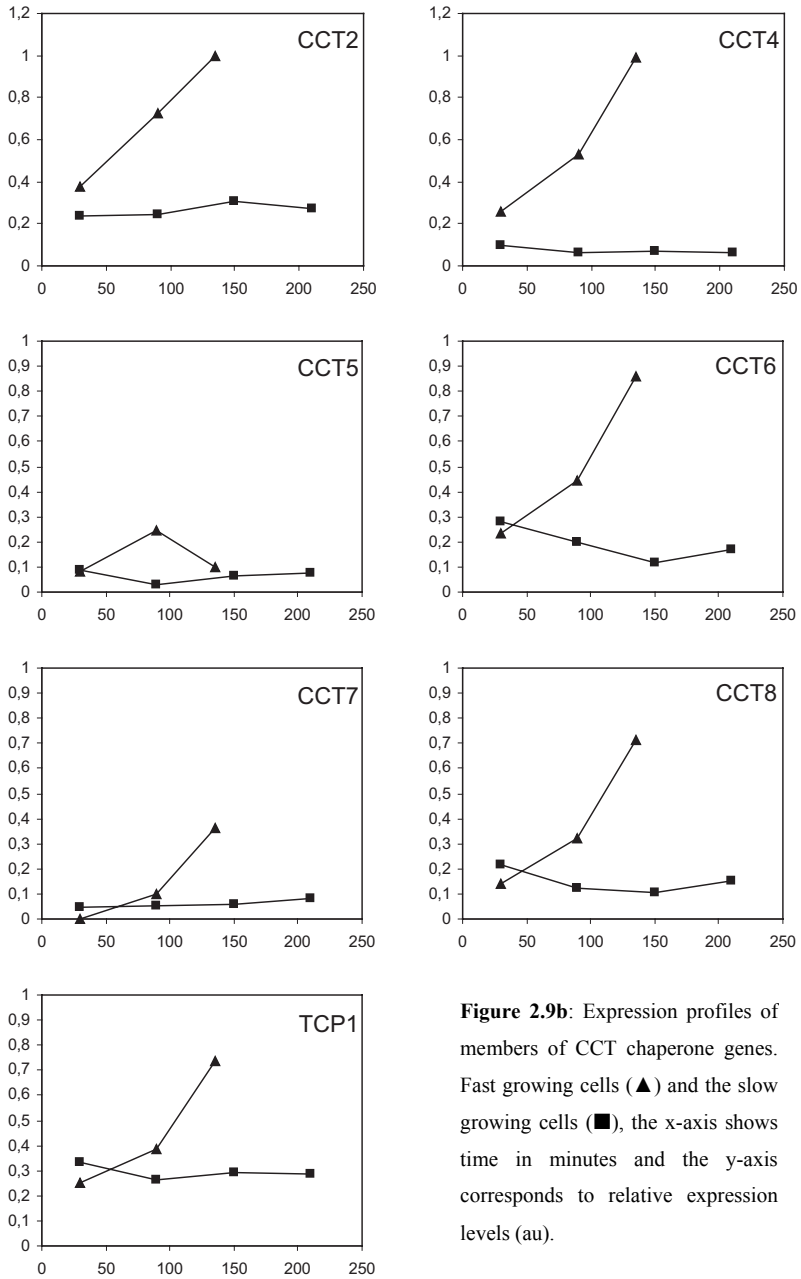
### **DNA damage genes are not affected by slow growth but sub-telomerically encoded helicases are**

DNA damage and DNA stability are of major importance in determining longevity. To establish whether these processes are changed by caloric restriction, expression patterns of the corresponding genes were examined.

Several proteins are able to bind damaged DNA. None of the corresponding genes are expressed at high levels in either dataset apart from *MSH6*, which shows a transient increase during fast growth. This gene is supposed to recognize single base-pair mismatches (Marsischky *et al.*, 1996). However, Spellman *et al.* showed that it displays a cell cycle dependent expression pattern (Spellman *et al.*, 1998). The lack of expression of other DNA damage binding genes indicates that it is not very likely that there is any DNA damage formed under these circumstances. Other genes involved in organizing DNA stability are the histone deacetylases (15 genes), histone acetyl transferases (26 genes) and helicases (49 genes). Apart from histone deacetylase *CPR1* and histone acetyl transferase *AHC1* these genes all show very low expression levels. Of

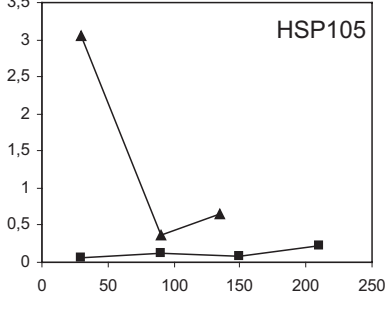
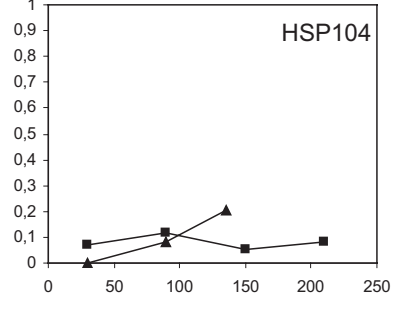
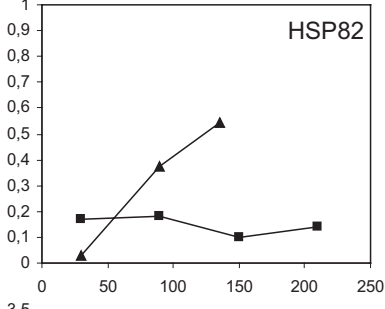
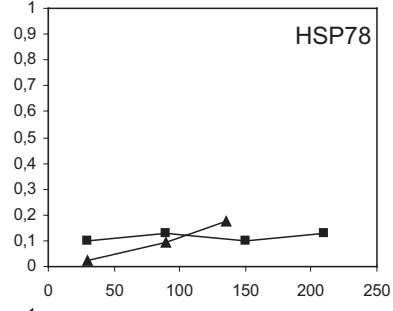
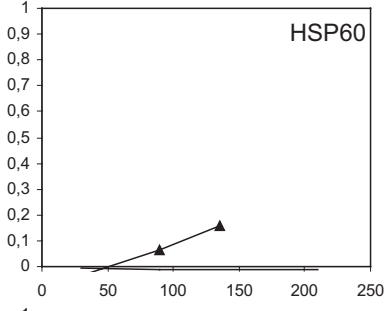
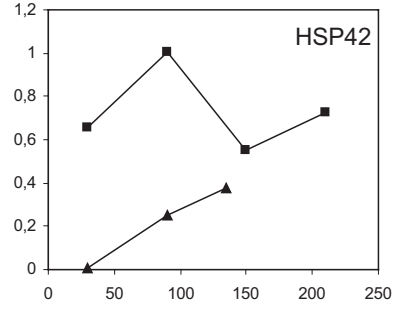
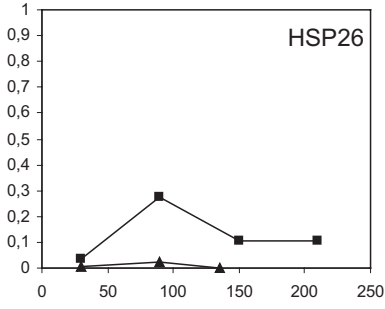
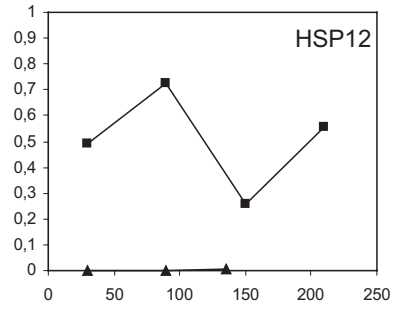
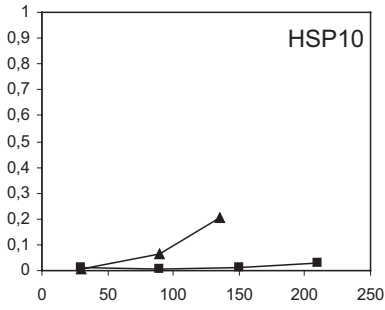


**Figure 2.9a:** Expression profiles of members of the HSP70 family. Most of these genes show higher levels in the fast growing cells (▲) than in the slow growing cells (■), the x-axis shows time in minutes and the y-axis corresponds to relative expression levels (au).



**Figure 2.9b:** Expression profiles of members of CCT chaperone genes. Fast growing cells (▲) and the slow growing cells (■), the x-axis shows time in minutes and the y-axis corresponds to relative expression levels (au).





**Figure 2.9c:** Expression profiles of members of other heatshock proteins. Fast growing cells (▲) and the slow growing cells (■), the x-axis shows time in minutes and the y-axis corresponds to relative expression levels (au).

the 49 proteins with helicase activity there are 28 genes located near the telomeres. It is interesting to notice that of these sub-telomerically encoded helicases, 15 genes are higher expressed in the fast growing cells. Besides these helicases also other genes are encoded at the telomeres. *SEO1*, *COS5*, *COS6* and *COS7* display the same transcription profile as these helicases (see table 2.1). These data indicate that there is no DNA damage in either slow or fast growing cells and that silencing of telomeres is less during fast growth.

**Table 2.1:** Sub-telomerically located genes at both far ends of the chromosomes. The bold genes are the ones that are expressed at higher levels in the fast growing cells.

#	Left-end			...	Right-end		
	first	first -1	first -2		last -2	last -1	last
I	YAL069W	YAL068C	<b>SEO1</b>	...	IMD1	YAR074C	YAR075W
II	<b>YBL113c</b>	YBL112C	<b>YBL111C</b>	...	YBR300C	DAN3	COS2
III	YCL076W	YCL073C	YCL069W	...	ADH7	RDS1	AAD3
IV	<b>COS7</b>	MPH2	SOR2	...	YDR543C	YDR544C	<b>YRF1-1</b>
V	<b>YEL077C</b>	YEL076C	YEL075C	...	YER188W	YER189W	<b>YRF1-2</b>
VI	YFL068W	<b>YFL067W</b>	<b>YFL066C</b>	...	<b>YFR055W</b>	YFR056C	YFR057W
VII	COS12	YGL262W	YGL261C	...	YGR294W	<b>COS6</b>	<b>YRF1-3</b>
VIII	<b>YHL050C</b>	<b>YHL049C</b>	COS8	...	YHR217C	<b>YHR218W</b>	<b>YHR219W</b>
IX	YIL177C	YIL176C	YIL175W	...	YIR042C	YIR043C	YIR044C
X	YJL225C	PAU1	VTH2	...	MPH3	<b>COS5</b>	YJR162C
XI	YKL225W	YKL224C	YKL223W	...	NFT1	YKR105C	YKR106W
XII	<b>YLL067C</b>	<b>YLL066C</b>	YLL065W	...	YLR465C	<b>YRF1-4</b>	<b>YRF1-5</b>
XIII	<b>YML133C</b>	COS3	YML131W	...	YMR324C	YMR325W	YMR326C
XIV	YRF1-6	YNL338W	YNL337W	...	COS10	PAU6	YNR077C
XV	YOL166C	AAD15	YOL164W	...	YOR392W	ERR1	YOR394W
XVI	<b>YRF1-7</b>	YPL282C	ERR2	...	ANT1	SCD6	YPR130C

## Discussion

By using elutriated synchronous virgin daughter cells and a fed-batch setup, expression profiles of slow and fast growing cells could be compared with each other. The slow growing cells are restricted in their access to carbon sources and can therefore be considered as caloric restricted cells. The advantages of the used approach are that both cultures are at the same phase of the cell cycle, in G1, and that all cells are at the start of their life cycle. Previous research showed that the duration of the cell cycle is mainly determined by the amount of time spent in G1 (Carter and Jagadish, 1978; Silljé *et al.*, 1997) so the growth rate is almost synonymous with G1 duration, which is the rationale of the comparison of the transcription profiles only during G1. On top of this, culture conditions are much better defined using this setup. Although it remained to be seen whether imposing slow growth conditions on virgin daughter cells would reveal differences, it turned out that several groups of genes showed variations in expression which can contribute to the longevity effect found in slow growing caloric restricted cells.

The experiments described in this chapter show a comparison between the transcriptional profiles of slowly and fast growing cells. This revealed that NAD<sup>+</sup> metabolism is influenced in such a way that levels of nicotinamide are minimized in the slow growing cells. This will lead to more active Sir2 and thereby increased genetic stability. Besides this observation, an increase in stress response during slow growth was observed, both an increase in genes involved in the synthesis of stress protectant trehalose and several members of the oxidative stress response. Also several subunits of the proteasome showed higher expression during the slow growth conditions.

Our experiments show that *PNC1*, which codes for an enzyme involved in recycling nicotinamide to NAD<sup>+</sup>, is expressed at higher levels during the slow growth. This suggests that less nicotinamide, which is a Sir2 inhibitor, leads to more active Sir2, more histone deacetylation, more silencing and subsequent longevity. *NPT1*, which takes care of subsequent steps of the recycling, seems to be less important during caloric restriction. This underlines the important role of nicotinamide for Sir2 regulation and tempers the role of NAD<sup>+</sup>. This effect on silencing is confirmed by the expression of several genes located near the end of the telomeres in the fast growing cells. This indicates that there is less silencing in the fast growing cells.

These results fit with earlier mentioned models regarding  $\text{NAD}^+$  and nicotinamide as the central metabolites regulating longevity and genetic stability. However, other observations, most notably the increase in stress response and the higher level of several subunits of the proteasome indicate that there is more. When the yeast encounters high sugar concentrations, most of its energy will be derived from the fermentation process transforming sugar into ethanol. If these sugar levels decrease, a shift to respiration will occur including the oxidation processes in the mitochondria. This will give rise to escaping electrons, which are able to form oxygen radicals. Apparently these radicals trigger a specific oxidative stress response during the slow growth conditions. The increase in respiration and accompanying increase in oxygen radicals explains the increase transcriptional levels of the proteasome subunits. If these radicals are able to induce protein oxidation, the proteasomes are needed to clear up the damaged proteins. It has been shown before in mice that caloric restriction leads to increased protein turnover (Lee *et al.*, 1999a). However, there is no evidence that there is indeed protein or other cellular damage. For instance, the complete absence of any DNA damage regulated transcripts shows that it is not very likely that major damage has been done in these cells. Also the difference in expression of the *HSP70* family between the slow and fast growing cells does not suggest that caloric restriction induces major denaturation to occur. However the cell is probably anticipating bad times and therefore already fortifying its defences. This is in line with the accumulation of reserve carbohydrate and stress protectant trehalose during slow growth conditions (Verwaal, 2003). This accumulation starts already at times when there is still plenty of extracellular glucose left, thus an example optima forma of ‘an anticipating cell’. This behaviour is observed in our experiments too, where the trehalose synthesizing genes show higher expression levels during caloric restriction. Considering trehalose as a general stress protectant, it is part of the caloric restriction induced response to outlive periods of scarcity.

It has been shown that raising the extracellular concentration of glucose can also increase lifespan considerably (Kaeberlein *et al.*, 2002). This was explained by pointing out that these high concentrations of glucose lead to an osmotic stress response, which involves glycerol synthesis as an osmoprotectant. This glycerol synthesis has as by-product  $\text{NAD}^+$  so again Sir2 activity would be affected. However, exposing cells to high osmolarity also leads to a stress response, a decrease in growth rate and a decrease in PKA activity (Norbeck and Blomberg, 2000). This decrease will influence the

expression of several genes like for instance *PNC1*. A search in the upstream region revealed that this gene has 4 STRE elements within its promoter important for activation by Msn2/4 (van Helden *et al.*, 2000), which in turn is under negative control of PKA (Smith *et al.*, 1998). *NPT1* has no STRE elements within its promoter, which could explain the difference in expression pattern. Apparently, although *PNC1* and *NPT1* are both involved in the NAD<sup>+</sup> salvage pathway, they are regulated in a different manner.

It is clear that exposure of cells to adverse growth conditions like low sugar levels (caloric restriction), high sugar levels (osmotic stress) and high temperatures (Shama *et al.*, 1998; Swiecilo *et al.*, 2000) results in slowing down the cell cycle and the growth rate. On the other hand it is known that caloric restricted induced growth rate reduction will lead to extension of replicative lifespan. It seems that adverse growth conditions could have a surprising side-effect called longevity. This observation has much in common with the hormesis theory of Masoro (Masoro, 1998), which postulates that low doses of potential harmful substances can be beneficial on the long run. Apparently caloric restriction is only one of several treatments able to increase lifespan in *S.cerevisiae*, which all have in common that besides inducing longevity the growth rate is decreased. It is probable that this decrease in growth rate is an effect of decreased PKA activity, which is also at the basis of the increased stress response.



3

*The expression of several components of the thioredoxin system after exposure to hydrogen peroxide is dependent on the phase of the cell cycle*

**Abstract:**

Previous experiments showed that an oxidative stress response is involved in the G1 phase of slow growing cells. Experiments were conducted to establish whether the transcription of mRNA coding for antioxidant proteins is affected by oxygen radicals during the cell cycle in *Saccharomyces cerevisiae*. To investigate this, microarray analysis was performed with mRNA samples of yeast cells progressing through the cell cycle in the presence or absence of 0.1 mM hydrogen peroxide. This revealed that several components of the thioredoxin system show both a cell cycle, with the emphasis on the S-phase, and stress dependent expression pattern. This is not observed with the glutathione system or with the catalases. These results suggest a more stringent and specific defence during the S-phase to protect the vulnerable unwound DNA during replication.



## Introduction:

As shown in the previous chapter, the oxidative stress response seems to be involved during lifespan increasing treatments like caloric restriction. The yeast cell is able to express a wide variety of proteins that can protect the cell against the detrimental effects of oxygen radicals. There are several classes to be distinguished among these defence systems. The two main systems, the glutathione and the thioredoxin system, use a substrate that is subsequently oxidized and reduced by different enzymes that finally obtain their electrons from NADPH (Stephen and Jamieson, 1996). The difference between these two systems is that the glutathione system uses a tripeptide, called glutathione as the recycling molecule and that the thioredoxin system uses a small protein of approximately 100 amino acids called thioredoxin for this purpose. Besides the thioredoxin and the glutathione system, are the catalases, the superoxidedismutases and small molecular antioxidants as vitamins C and E.

The thioredoxin system is composed of several proteins. Some of the proteins use thioredoxin as the reducing equivalents while others are involved in reducing the oxidized thioredoxin. Carmel-Harel and Storz (Carmel-Harel and Storz, 2000) mention a list with 10 genes being part of the thioredoxin system and 11 genes being part of the glutathione system.

Three different forms of thioredoxin are known; Trx1, Trx2 and Trx3 of which only the latter is supposed to be localized in the mitochondrion whereas the other two are mainly cytoplasmic (Pedrajas *et al.*, 1999). The oxidation of these proteins is catalyzed by thiolperoxidases of which five are known to exist so far, called Ahp1, Dot5, Tsa1, Tsa2 and Prx1 (Park *et al.*, 2000). Also these proteins have different localizations within the cell. Ahp1, Tsa1 and Tsa2 are located in the cytoplasm while Dot5 is in the nucleus and Prx1 is in the mitochondria. The reduction of the oxidized thioredoxin proteins is carried out by two thioredoxin reductases called Trr1 and Trr2, which are located respectively in the cytosol and the mitochondria (Pedrajas *et al.*, 1999; Kumar *et al.*, 2002).

Glutathione is synthesized in two subsequent steps by  $\gamma$ -glutamyl cysteine synthetase, Gsh1, and glutathione synthetase, Gsh2 (Ohtake and Yabuuchi, 1991). The reduction of hydrogen peroxide is accomplished by dimerization of two tripeptides in the presence of a glutathione peroxidase of which three are present in the cell i.e. Gpx1, Gpx2 and Hyr1. Deletion of all three peroxidases decreases glutathione peroxidase

activity to 7% (Inoue *et al.*, 1999). The reduction of the oxidized glutathione is catalyzed by a glutathione reductase called Glr1 (Grant *et al.*, 1996a). There are another five glutaredoxins Grx1, Ttr1, Grx3, Grx4, Grx5 of which at least Grx5 is involved in maintaining glutathione in reduced state (Shenton *et al.*, 2002) while Grx1 and Ttr1 act as glutathione dependent oxidoreductases (Collinson *et al.*, 2002).

The mode of action of the catalases and the superoxide dismutases is different from above mentioned mechanisms because they are directly involved in transforming dangerous radical oxygen species into (less) harmless molecules. The superoxide dismutases, Sod1 and Sod2, transform superoxide radicals into hydrogen peroxide by catalyzing the addition of protons (Fridovich, 1975; Hart *et al.*, 1999). The two catalases, Cta1 and Ctt1, are subsequently able to convert the hydrogen peroxide to water and oxygen (Grant *et al.*, 1998).

The two main regulators of antioxidant genes are Yap1 and Skn7. Deletion of either of them renders the cells extremely sensitive to oxidative stress. Although some genes are regulated by both factors it has been shown that each controls a different set of transcripts (Lee *et al.*, 1999b).

Old mother cells produce daughter cells with diminished offspring producing capabilities. However, this is restored within a few generations (Kennedy *et al.*, 1994). This suggests that permanent DNA damage does not occur in this case, apparently the DNA is rather well protected. Vulnerability of DNA to oxygen radicals is probably different during the cell cycle due to the necessity to unwind the DNA during replication that occurs in the S-phase. To establish whether the expression of the antioxidant defences is induced during this phase, several experiments were conducted. *S. cerevisiae* cells were synchronized by centrifugal elutriation and subsequently transferred to fresh medium (Silljé *et al.*, 1997). During progression through the cell cycle, samples were taken and exposed to hydrogen peroxide. mRNA of these samples was isolated and 3 timepoints were selected representing cells in G1, G1/S and S-phase. Radioactively labelled cDNA was made from the mRNA transcript pools and hybridized with microarray filters. In this way transcript levels of all yeast ORFs including those of the antioxidant systems were monitored at the same time.

Most of the genes of the thioredoxin system were upregulated by stress at the three measured timepoints while the glutathione system and the catalases were not. Moreover, several thioredoxin peroxidases showed, besides the induction by oxidative

stress, that their induction also depends on the phase of the cell cycle. An additional increase was observed in expression in S-phase. After describing this behaviour in three simple mathematical equations, these equations were used with our database to find also other genes demonstrating this feature. 10 genes were found, most of which were stress genes and some involved in metal ion homeostasis. These results indicate an upregulation of DNA protecting enzymes at a specific stage of the cell cycle, the S-phase.

## Materials and Methods:

### Strains and growth conditions:

In all experiments the wildtype strain CEN-PK113-7D (*MATa SUC2 MAL2-8c MEL*) also known as VWk43 was used. Cultures were grown at 30°C in a rotary shaker at 180 rpm in Yeast Nitrogen Based medium w/o amino acids (YNB, Difco, Detroit, USA) with 1-2 % glucose or galactose as indicated.

### Centrifugal elutriation:

Synchronous cells were obtained by centrifugal elutriation as described by Silljé et al. (Silljé *et al.*, 1997). Cells were grown in 1 litre of YNB with 1 % galactose at 30°C until they reached an OD600 of 2.0. The cells were harvested in a centrifuge at room temperature and sonicated twice for 20 seconds to disturb cell clumps while kept on ice. They were loaded into an elutriator spinning at 2000 rpm (Beckman J-6 MI, Mijdrecht, Beckman Coulter Netherlands) with a 40 ml chamber kept at 30°C. Using a Masterflex pump from Cole-Parmer (Aplikon, Schiedam, Netherlands) YNB medium containing 1 % galactose was pumped into the chamber, washing away the newly formed daughter cells, which were subsequently collected on ice. After centrifuging, cells were kept overnight in YNB 1 % galactose on ice. After refreshing the medium, the cells were followed during the cell cycle by monitoring their budding percentages. At least 100 cells per timepoint were counted.

### mRNA isolation:

mRNA was isolated using a phenol/chloroform extraction as described in Maniatis (Sambrook *et al.*, 1989) with modifications. Samples of 10 ml were quickly frozen by immersion in liquid nitrogen. After slowly thawing the cells and washing them with 1 ml extraction buffer (100 mM Tris-HCl (pH 7.5), 100 mM LiCl, 10 mM EDTA), cells were resuspended in 0.5 ml vortex buffer (100 mM LiCl, 10 mM EDTA, 0,5 % LithiumDodecylsulphate, pH 7.5 with LiOH). Vigorous shaking with 0.45 mm glass beads in a bead-beater (Biospec products, Bartlesville, OK, USA) disrupted cell walls and membranes after which a phenol chloroform extraction was performed. After addition of 50 µl 3M NaAc and 1.25 ml ice-cold ethanol, the mRNA was precipitated at

-80°C, samples were centrifuged, washed with cold ethanol (70 %), air-dried and resuspended in water.

### **Microarray experiments:**

Microarray experiments were conducted as described by Schoondermark-Stolk et al. (Schoondermark-Stolk *et al.*, 2002). Isolated pools of transcripts were labelled with radioactive dCTP. This labelling is performed by making cDNA from the isolated mRNA in the presence of radioactively labelled nucleotides. 4 µg of RNA (measured at 260 nm) was mixed with 2 µl of OligodT (1 µg/µl), to a final volume of 10 µl. The following components were added: 6 µl of first strand buffer (Life Technologies, Breda, The Netherlands), 1 µl of 0.1 M dithiothreitol, 1.5 µl of a mixed solution containing 100 mM of dATP, dGTP and dTTP, 300 units of Superscript II reverse transcriptase (Life Technologies) and 100 µCi [<sup>33</sup>P]CTP (Amersham Biosciences, Roosendaal, The Netherlands). The mixture was kept at 37°C for 90 min. after which 70 µl of STE (0.1 M NaCl, 10 mM TRIS.HCL (pH 8.0), 1 mM EDTA (pH 8.0)) was added. The newly synthesized cDNA was then purified by passage through a Sephadex G-50 column (Amersham Biosciences) and washed with 350 µl of STE after which it was eluted with 500 µl of STE. The cDNA was denatured by heating it to 100°C for 3 min.

Yeast GeneFilter microarrays (ResGen, Invitrogen, Breda, The Netherlands) were washed for 5 min. with boiling 0.5 % SDS. The membranes were prehybridized for 4 h with 5 ml MicroHyb solution (ResGen) and 5 µl OligodA (ResGen) at 42°C in a roller oven (Thermo Hybaid, Landgraaf, The Netherlands). The labelled cDNA probes were added to these prehybridized filters and incubated over night at 42°C. The next day, the filters were rinsed with 2xSSC (diluted from 20xSSC which contains: 3 M NaCl, and 0.3 M Na-citrate, pH 7.0) and 1 % SDS for 20 minutes at 50°C. This was repeated once, after which an additional rinsing step followed with 0.5xSSC with 1 % SDS for 15 minutes at room temperature. The filters were then transferred to a humid 3-layer Whatman filter, wrapped in Saran foil and placed against a Phosphor screen (Molecular Dynamics, Sunnyvale, CA, USA). After 6 days of exposure the screen was read by a phosphorimager SI (Molecular Dynamics) coupled to a computer. The samples with hydrogen peroxide were hybridized twice to different microarray filters and the samples without hydrogen peroxide once.

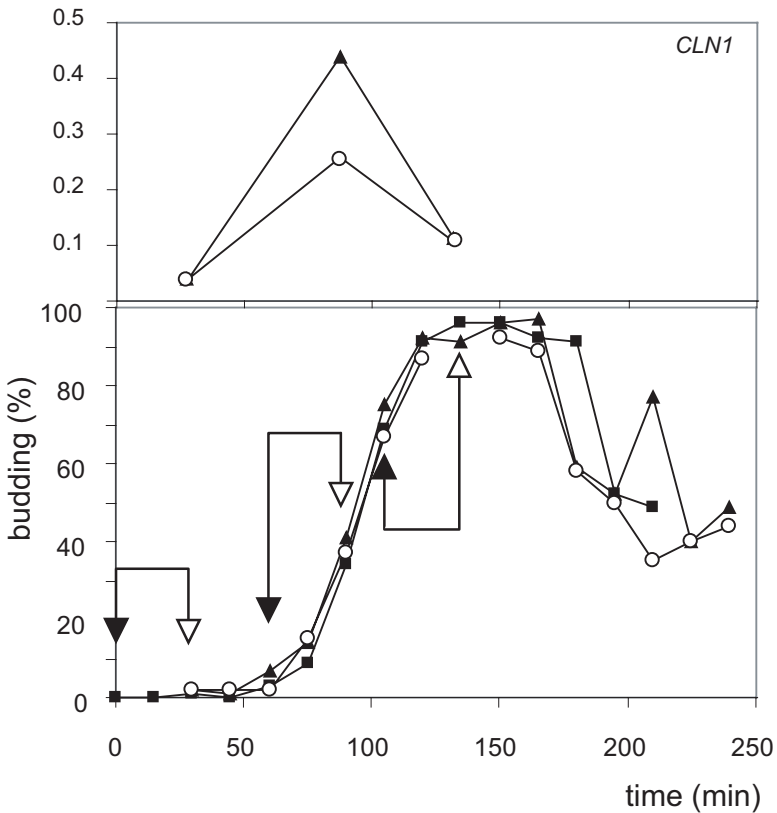
### **Data analysis and spot validation:**

Images were scanned at 50- $\mu\text{m}$  resolution in Image-Quant 5.1 (Molecular Dynamics) and then imported into the ImaGene 4.2 microarray analysis software (BioDiscovery, Marina del Rey, CA, USA). Standard grids were placed over the images of the arrays after which spotsize was fixed at 15 pixels and the 'autoadjust spot' function was applied, which corrects for slight deviations of the grid. Very intense spots tend to 'blossom' out their signal, leading to an increase of signal in surrounding spots. Usually these surrounding spots were 'flagged' by hand. Flagged data were not used. Although ImaGene has various features to quantify background and signal intensities per spot, it was preferred to use local blank spots as background values except when these spots were flagged. In this case the local blank spot of one row ahead was used. All the quantified data were imported into an Excel sheet (Microsoft) after which the identities of the different genes were added. Values used were the signal mean values, which are the total signal values divided by the area. Normalization was usually carried out by dividing the values through the average of all spot intensities, although in some cases it was performed by dividing through metacolumn average values.

## Results:

### The effect of hydrogen peroxide on cell cycle progression

Synchronous daughter cells were isolated from an asynchronous growing culture by centrifugal elutriation. The cells were transferred to fresh medium after which their budding profile was followed in time. Every 15 minutes two samples were taken from this culture, one of which was subsequently exposed to 0.1 mM hydrogen peroxide for 30 minutes. Both samples were kept at 30°C and their budding profiles were followed in time. As shown in figure 3.1, budding started to increase at 60 minutes

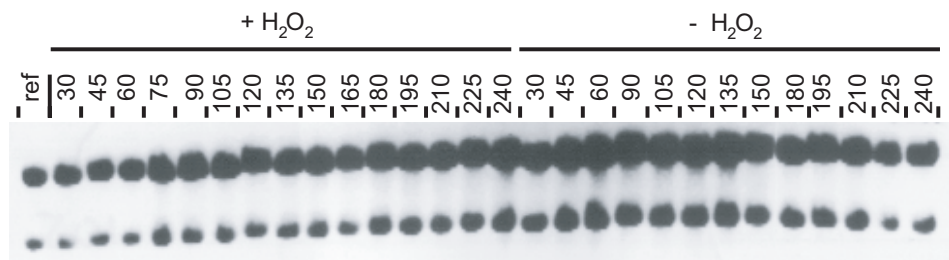


**Figure 3.1:** Cells progressing through the cell cycle with and without hydrogen peroxide and the corresponding *CLN1* expression. In the lower graph is the budding profile of cells progressing through the cycle depicted. Reference cells (■), cells incubated at 30°C with 0.1 mM hydrogen peroxide for 30 minutes (▲), cells incubated at 30°C without hydrogen peroxide for 30 minutes (○). The three timepoints that were used for the microarray experiments are indicated with the black and white arrows. Black arrows indicate time points at which samples were taken and stressed with or without hydrogen peroxide. The white arrows indicate the time points at which the mRNA was isolated. In the upper graph are the expression levels of *CLN1* visualised at the specific selected timepoints.

and reached a maximum of almost 100% after 135 minutes. This indicates that S-phase starts around 100 minutes. Both the hydrogen peroxide exposed and the control cells show the same budding pattern, indicating that the 30-minute exposure to hydrogen peroxide does not influence cell cycle progression. Based on figure 3.1, three timepoints were selected for microarray analysis, representing different phases of the cell cycle. Timepoint  $t = 30$ ,  $t = 90$  and  $t = 135$  minutes, were chosen to represent G1-phase, G1/S transition and S-phase respectively. This was eventually confirmed by, amongst other things, the expression levels of *CLNI*, which showed low expression at  $t = 30$  and  $t = 135$  and higher expression at  $t = 90$  minutes both in the cells with and without hydrogen peroxide (see figure 3.1). This is in line with earlier research performed in our lab and others placing expression of *CLNI* just ahead of the G1/S-phase transition (Benton *et al.*, 1993; Silljé *et al.*, 1997).

### The influence of the cell cycle phase on stress response

Isolating mRNA samples, as described in Materials and Methods, and using them for microarray experiments revealed quantitative information about transcript levels during the cell cycle with and without exposure to oxidative stress. As shown in figure 3.2 no apparent breakdown of the mRNA was detected, the ribosomal RNA bands are clearly visible in both the samples exposed to hydrogen peroxide and in the control samples. Total amounts of RNA loaded were equal as measured by spectrophotometry, however, ribosomal RNA is less present in the cells exposed to hydrogen peroxide. As mentioned before, only timepoints 30, 90 and 105 minutes were used for microarray experiments. Isolated mRNA of these timepoints was translated to radioactively labelled cDNA and hybridized with a microarray filter containing spots



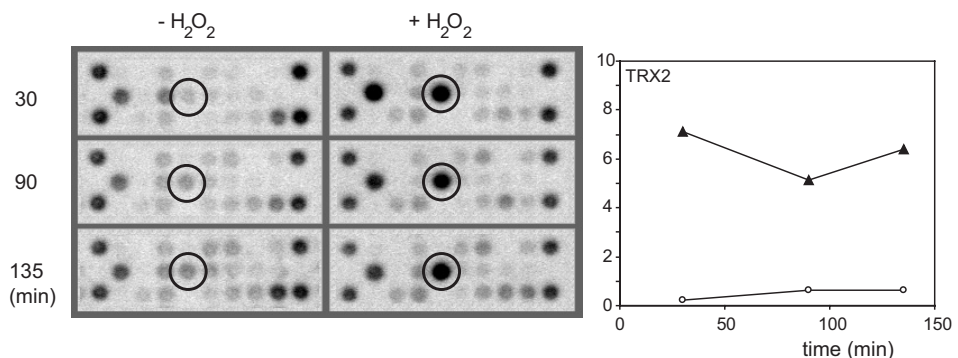
**Figure 3.2:** Ribosomal RNA bands of mRNA samples. mRNA from cells progressing through the cell cycle with and without hydrogen peroxide show no degradation. The numbers above the gel indicate the minutes passed.



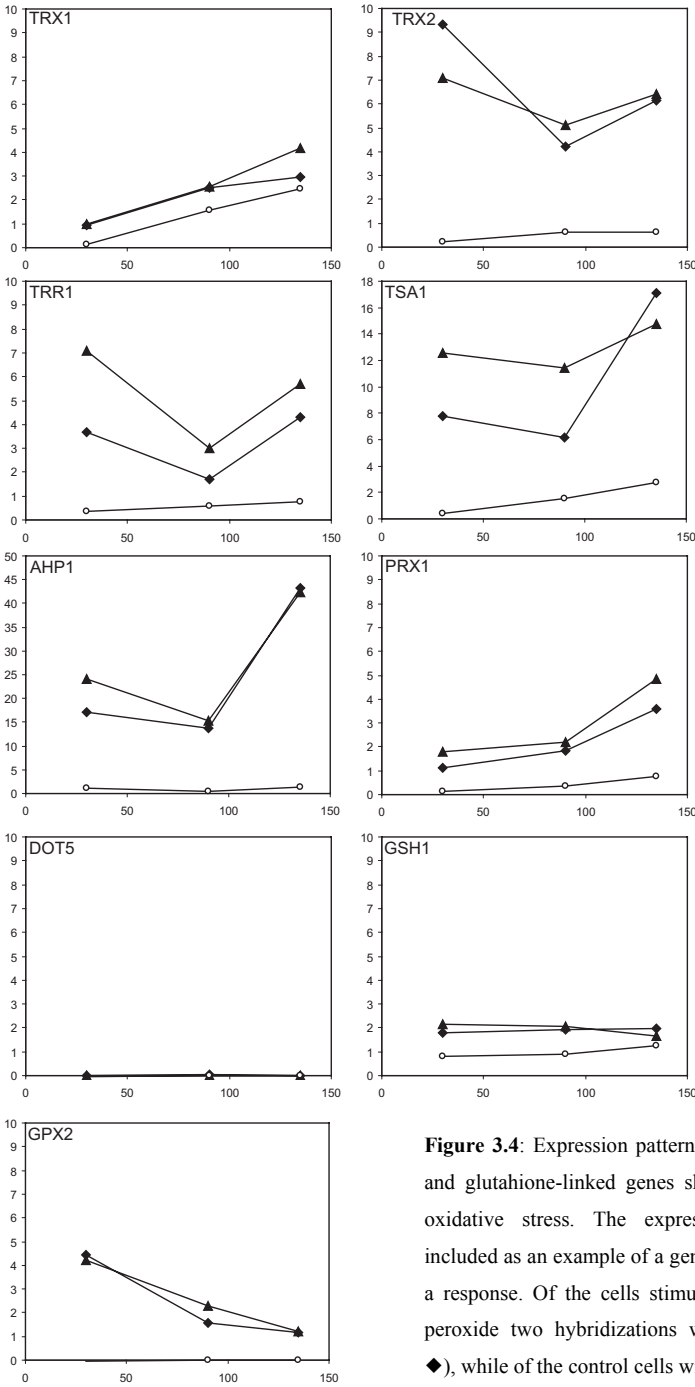
consisting of single stranded DNA coding for 6144 known yeast ORFs. After exposing these filters to a phosphorimager screen the amount of radioactive signal was quantified yielding absolute expression levels of each transcript.

### Expression of components of the thioredoxin system during the cell cycle with and without exposure to hydrogen peroxide

*TRX2* mRNA during the cell cycle after addition of hydrogen peroxide showed continuously high levels of expression as is shown in figure 3.3. In this figure the microarray filters of the samples that were not exposed to hydrogen peroxide show low expression of the *TRX2* transcript while the filters used with the samples exposed to hydrogen peroxide show a continuously high level of expression. In addition to Trx2, 9 other components are part of the thioredoxin system i.e. 3 thioredoxins, 5 peroxidases and 3 reductases respectively. *TRX3*, *TRR2*, *TSA2* and *DOT5* are not expressed, neither in the cells with hydrogen peroxide, nor in the cells without. The other components, *TRX1*, *TRX2*, *TRR1*, *TSA1*, *AHP1* and *PRX1* are expressed at low expression levels when no hydrogen peroxide is present at every timepoint except for *TRX1* and *TSA1* which expression increases during the cycle. However, in the presence of hydrogen peroxide a different picture arises. *TRX1*, *TRX2*, *TRR1*, *TSA1*, *AHP1* and *PRX1* are all upregulated at every timepoint by the addition of hydrogen peroxide compared to the samples where no hydrogen peroxide is present. Besides the response to hydrogen



**Figure 3.3:** The expression of *TRX2* on filter and the quantified data from ImaGene 4.2. On the left the phosphorimages of the mRNA hybridization of the cells with and without stress, with the *TRX2* spots encircled. On the right are the quantified intensities of these spots. Relatively constant high expression of *TRX2* mRNA in the samples that were stimulated with hydrogen peroxide (▲) compared to the cells that were not stimulated (○).



**Figure 3.4:** Expression patterns of the thiredoxin- and glutathione-linked genes showing responses to oxidative stress. The expression of *DOT5* is included as an example of a gene that does not show a response. Of the cells stimulated with hydrogen peroxide two hybridizations were performed (▲, ◆), while of the control cells without stress only one hybridization (○) was performed.

**Table 3.1:** The components of the major antioxidant systems; thioredoxin and glutathione, and their response to stress in the earlier described experimental setup.

Name	Description	Class	Responsive?
TRX1	Thioredoxin I	Thioredoxin	Yes
TRX2	Thioredoxin II	Thioredoxin	Yes
TRX3	Mitochondrial thioredoxin	Thioredoxin	No
TRR1	Thioredoxin reductase	Reductase	Yes
TRR2	Mitochondrial thioredoxin reductase	Reductase	No
TSA1	Cytosolic thioredoxin peroxidase	Peroxidase	Yes
TSA2	Cytosolic thioredoxin peroxidase	Peroxidase	No
AHP1	Alkyl hydroperoxide reductase	Peroxidase	Yes
DOT5	Nuclear thioredoxin peroxidase	Peroxidase	No
PRX1	Mitochondrial thioredoxin peroxidase	Peroxidase	Yes
GSH1	$\gamma$ -Glutamylcysteine synthetase	Synthetase	Yes
GSH2	Glutathione synthetase	Synthetase	No
GLR1	Glutathione reductase	Reductase	Slightly
GRX1	Glutaredoxin containing 2 cysteines	Glutaredoxin	No
TTR1	Glutaredoxin containing 2 cysteines	Glutaredoxin	No
GRX3	Glutaredoxin containing 1 cysteine	Glutaredoxin	No
GRX4	Glutaredoxin containing 1 cysteine	Glutaredoxin	No
GRX5	Glutaredoxin containing 1 cysteine	Glutaredoxin	No
GPX1	Glutathione peroxidase	Peroxidase	No
GPX2	Glutathione peroxidase	Peroxidase	Yes
HYR1	Glutathione peroxidase	Peroxidase	No

peroxide, also the phase of the cell cycle is influencing the expression of the genes mentioned above. Especially the thiolperoxidases show an additional increase at  $t = 135$  min (see table 3.1 and figure 3.4). Apparently the stress response is in this case cell cycle dependent.

### **Expression of components of the glutathione system during the cell cycle with and without exposure to hydrogen peroxide**

As described in the introduction, the glutathione system consists of 11 components, including the synthetases, peroxidases, reductases and redoxins. Our microarray data reveals that apart from two genes i.e. *GSH1* and *GPX2*, none of the components are induced either in the cells exposed to hydrogen peroxide or the control cells at any timepoint. *GSH1* shows equal induction by hydrogen peroxide during the cell cycle at every timepoint while *GPX2* demonstrates a decreasing signal (see table 3.1 and figure 3.4).

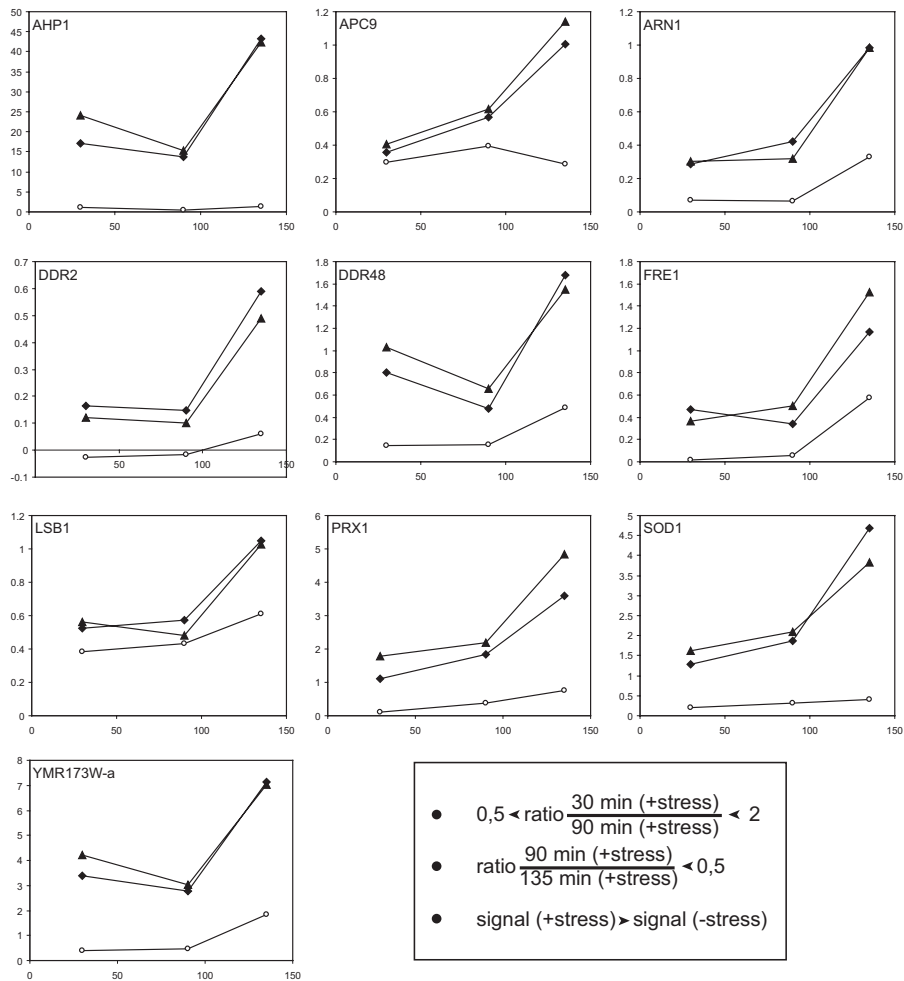
From table 3.1 is concluded that the thioredoxin system is more responsive than the glutathione system. The proteins responsible for inducing both systems, *YAP1* and *SKN7*, show no response on transcriptional level to the applied stress.

### Several other genes show changing expression during the cell cycle

Besides the influence of exposure to oxidative stress, also the phase in which the cells reside influences expression levels of antioxidant proteins. Especially the three thiolperoxidases *AHP1*, *PRX1*, and *TSA1* display an additional increase in expression at 135 minutes (see figure 3.4). This behaviour can be described with three equations depicted in figure 3.5. They state that ratios between timepoint 90 min. and 135 min. have to be smaller than 0.5 denoting the additional increase, the ratios between 30 min. and 90 min. have to be between 2 and 0.5 and that the signal of the cells exposed to hydrogen peroxide has to be larger than the signal of the control cells. Applying these three equations on our database revealed 23 genes showing an expression pattern similar to *AHP1* of which only 10 genes were expressed above background levels. These genes are listed in table 3.2 and their expression patterns are depicted in figure 3.5. In this table and corresponding figure, there are two thiolperoxidases. However, also two *DDR* (DNA Damage Responsive) genes display behaviour similar to expression of *AHP1*. Also *SOD1*, which is a superoxide radical scavenger, shows this additional upregulation in the S-phase. It is less clear why the other genes in table 3.2 are upregulated after induction with hydrogen peroxide during S-phase of the cell cycle. *Apc9* is a subunit of

**Table 3.2:** Genes showing expression patterns like *AHP1*.

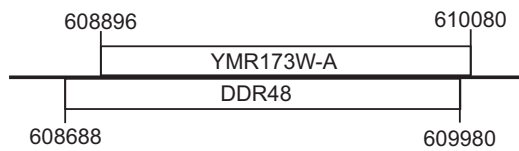
Name	Description
AHP1	Alkyl hydroperoxide reductase, thiolperoxidase
PRX1	Thiolperoxidase
DDR2	Response to stress
DDR48	Response to stress, DNA repair
SOD1	Cu/Zn superoxide dismutases
APC9	Subunit of anaphase promoting complex (APC), which prevents initiation of DNA synthesis
ARN1	Iron-sidechrome transporter
FRE1	Oxidoreductase, iron ion homeostasis
LSB1	Biological process unknown
YMR173W-A	Biological process unknown



**Figure 3.5:** Expression patterns of genes behaving similar to *AHP1*. Of the cells stimulated with hydrogen peroxide two hybridizations were performed (▲, ◆), whilst of the control without stress only one hybridization (○) was performed.

the anaphase-promoting complex, which is required for destruction of Clb2, Clb3, Clb5 via ubiquitination. This complex is also involved in blocking premature DNA replication in G1 (Irniger and Nasmyth, 1997). Furthermore, an *apc9* mutant is extremely sensitive to methylating agent methyl methanesulfonate (MMS) that can damage DNA (Begley *et al.*, 2002). Arn1 is involved in uptake of small iron binding proteins called ‘ferrichromes’. It is induced by cadmium treatment (Momose and Iwahashi, 2001) and is upregulated when treated with 0.32 mM hydrogen peroxide (Gasch *et al.*, 2000). Fre1 is involved in iron uptake and ferric ion reduction but could

also be involved in maintaining intracellular redoxpotential (Anderson *et al.*, 1992). Another interesting observation is that a *fre1* mutant is extremely sensitive to MMS (Begley *et al.*, 2002). The *Fre1* promoter has at least one putative Yap1-binding site within 1 kb upstream of the start codon (Carmel-Harel *et al.*, 2001). The one thing *Lsb1* has in common with *Fre1* and *Apc9* is that the knockout mutants of these genes are all very sensitive to MMS (Begley *et al.*, 2002). *YMR173w-a* is a hypothetical ORF with considerable overlap with *DDR48* (see figure 3.6), which explains its similar expression pattern.



**Figure 3.6:** YMR173 is a hypothetical ORF largely overlapping with the *DDR48* gene.

### **Expression of other antioxidant genes during the cell cycle with and without exposure to hydrogen peroxide**

Both catalases are not induced during the cell cycle with or without exposure to hydrogen peroxide. Also the transcription factors *YAP1* and *SKN7* show no clear response, although some values of *SKN7* are flagged so not reliable. *SOD1*, as mentioned before, shows increasing expression levels after exposure to hydrogen peroxide but even more induction during S-phase. However, *SOD2* does not show a clear response.

## Discussion:

DNA damage is a very serious injury that the cell needs to prevent. Each cell cycle, the DNA is duplicated at which stage it has to be unwound, potentially increasing its sensitivity to insults. It was therefore hypothesized that the cellular defences against oxygen radicals are dependent on the phase of the cell cycle. To obtain quantitative data about these expression levels, experiments were conducted with microarrays. This revealed the expression levels of 6144 ORFs during G1-phase, G1/S transition and S-phase of the cell cycle with and without exposure to oxidative stress. It was observed that exposing cells to 0.1 mM hydrogen peroxide for 30 minutes does not influence cell cycle progression significantly (figure 3.1) as shown by the similarities in the budding profiles. The observation that the samples exposed to stress show smaller rRNA bands (figure 3.2) is in line with earlier published results, which claim that hydrogen peroxide downregulates ribosomal genes (Gasch *et al.*, 2000).

It appeared that of the two major antioxidant systems, the thioredoxin system is better represented with 6 of the 10 components upregulated more than a factor 2 at each timepoint while of the glutathione system only 2 of the 11 genes show this upregulation (table 3.1, figure 3.4). The central protein in the thioredoxin system is Trx2. It seems that it is not influenced by the cell cycle, only the amount of hydrogen peroxide present is involved in its upregulation (figure 3.3). Of the ten components of the thioredoxin system there are five thiolperoxidases, i.e. *TSA1*, *TSA2*, *AHP1*, *DOT5*, and *PRX1*. Of these five thiolperoxidases both the nuclear *DOT5* and the cytosolic *TSA2* do not respond to the applied stress. Also the thioredoxin III (*TRX3*) and thioredoxin reductase II (*TRR2*) are not induced. The fact that both these proteins reside in mitochondria may imply that the hydrogen peroxide does not reach these organelles. However, this explains the lack of response only if *TRX3* and *TRR2* are regulated by factors directly or indirectly dependent on the oxidation state of the mitochondria. On the other hand, *PRX1*, the thiolperoxidase located in the mitochondria, is strongly induced by oxidative stress.

Of the glutathione system only 2 components were more than 2-fold upregulated. According to Gasch *et al.* (Gasch *et al.*, 2000) more components were upregulated after exposing an asynchronous culture to 0.32 mM hydrogen peroxide. This discrepancy may be caused by the fact that a higher concentration of hydrogen

peroxide was used as well as different growth media. This suggests that the thioredoxin system is activated at lower concentrations than the glutathione system.

Expression of transcription factors Yap1 and Skn7 is not induced by oxidative stress. However, the activity of Yap1 is regulated by import and export to and from the nucleus, so in this case transcript levels are not a good indication for the activity of this transcription factor and this can also be true for Skn7.

The more than 2-fold upregulation of several antioxidant genes like *AHP1* is dependent on the phase of the cell cycle as is shown in figure 3.4. Three of the five thiolperoxidases show an additional S-phase specific upregulation. By performing a search in the obtained database, ten genes were found displaying similar behaviour (table 3.2, figure 3.5). Two thioredoxin genes were found, *DDR2*, *DDR48* were induced next to its overlapping ORF *YMR173W-A* and also of *SOD1* was upregulated during S-phase. Why *SOD1* is upregulated is not clear, because it is not likely that superoxide radicals are present. Hydrogen peroxide is easily converted to hydroxyl radicals in the presence of a transition metal like copper or iron known as the Fenton reaction, but not to superoxide radicals. Sod1 is the protein that deals with these specific radicals. However, it has been described earlier that it is induced by hydrogen peroxide (Gasch *et al.*, 2000). Sod1 usually resides in the cytoplasm while Sod2 is located in the mitochondria, and does not show a clear response to hydrogen peroxide. Just as with earlier mentioned *TRR2* and *TRX3* this could be caused by the differences in localization although location specific signal transduction routes would be necessary for this. The proteins capable of converting hydrogen peroxide to water are the catalases, Cta1 and Ctt1, but their genes are not upregulated at all. These genes are upregulated in the dataset of Gasch *et al.*, but then again this may be caused by their use of a higher concentration of hydrogen peroxide.

Other genes display similar cell cycle dependent expression patterns as *AHP1* (table 3.2, figure 3.5). Both *ARN1* and *FRE1* have in common that they are induced by low levels of copper, but they also show this S-phase specific induction by hydrogen peroxide. The fact that both the *apc1*, *lsb1* and *fre1* mutants are extremely sensitive to MMS, which is a DNA damaging agent, suggests that the additional upregulation in S-phase could be a marker for DNA damage. Both the upregulation of DNA Damage Responsive genes *DDR2* and *DDR48* also indicate this potential DNA damage.



However, the important DNA damage genes like the *RAD* genes are not upregulated. It could be that the genes listed in table 3.2 are more involved in protecting the DNA before damage can be done while the *RAD* genes play a role in recognizing and repairing inflicted DNA damage.

According to Lee *et al.* (Lee *et al.*, 1999b) Yap1 and Skn7 are in control of two distinctive groups of genes. It is remarkable that most of the genes described to have a cell cycle dependent response to stress are in their list in the group of genes under control of both transcription regulators. The genes whose expression is governed by Yap1 alone do not seem to respond. This points to an important role of Skn7 in the cell cycle dependent response. It is not the first report of Skn7 being involved in cell cycle dependent processes. For instance, Bouquin *et al.* (Bouquin *et al.*, 1999) shows that Skn7 together with Mbp1 is necessary for bud emergence in G1-phase. It is therefore feasible that Skn7 is involved in the S-phase specific upregulation of certain transcripts.

DNA damage is supposed to be detrimental to the cell because mutations will be passed on to future generations. Therefore, the cell has developed defence systems to protect the DNA. However, during the cell cycle the DNA is replicated in S-phase in which it is unwound and more prone to all kinds of insults like the ones caused by radical oxygen species. Because of the supposed differences in vulnerability of the DNA during the cell cycle, it is reasonable that the expression of the defence mechanisms against ROS is also cell cycle dependent. Additional protection against oxidative stress during the S-phase is required and would explain the observed upregulation of the genes in table 3.2 and figure 3.5.

From our results can be concluded that several antioxidant proteins display an additional upregulation during S-phase indicating a more stringent defence against radical oxygen species during this phase probably to secure the DNA.



4

*R*esponse of TRX2-promoter-construct to hydrogen peroxide in *Saccharomyces cerevisiae* is cell cycle dependent

**Abstract:**

Previous experiments showed that several oxidative stress defence genes were activated in a cell cycle dependent manner after exposing them to hydrogen peroxide. The thioredoxin system is more responsive than the glutathione system. Thioredoxin2 is the main character in the thioredoxin system. Although it was measured that transcript levels were not influenced by the cell cycle, no data is published about protein levels of Trx2.

*Saccharomyces cerevisiae* cells were equipped with an oxygen stress reporterconstruct and synchronized by centrifugal elutriation. This construct consisted of a *TRX2* promoter sequence in front of a *LACZ* gene. The expression of the construct was followed in time with or without addition of 0.1 mM hydrogen peroxide. The cells that were not exposed to hydrogen peroxide showed a constant low expression level of the *TRX2* construct. The cells that were exposed to hydrogen peroxide, showed an increase in induction of the reporterconstruct around the start of S-phase. However, the expression of the *TRX2* mRNA showed continuous induction during all cell cycle phases upon exposure to hydrogen peroxide. The apparent contradicting result between the hydrogen peroxide induced mRNA expression and protein expression during G1 phase, was due to a low protein synthesis rate during early G1 as demonstrated by <sup>35</sup>S-labeled amino acid incorporation.

Therefore, the responses to oxidative stress are differentiated during the cell cycle and this is probably caused by a decreased protein synthesizing capacity in early G1 phase.

## Introduction:

Oxygen radicals are able to cause damage to different cellular constituents. Therefore, the cell has devised several systems to neutralize these harmful compounds. One of the major defence mechanisms against oxygen radicals is the thioredoxin system of which the key figure is thioredoxin2 (Trx2). Trx2 plays a role in reducing disulfide bonds (Muller, 1991) and is required for resistance against hydrogen peroxide (Kuge and Jones, 1994). Five thiolperoxidases, Tsa1, Tsa2, Ahp1, Dot5 and Prx1 use Trx2 as their reducing equivalent after which thioredoxin reductases Trr1 and Trr2 can reduce the Trx2 again, using NADPH in the process.

Trx2 is induced by cooperation of two transcription factors, Yap1 and Skn7, upon exposing cells to oxidative stress (Morgan *et al.*, 1997; Lee *et al.*, 1999b). Each controls its own 'regulon' of important antioxidant genes of which several genes come under regulation of both Yap1 and Skn7. Besides by the regulation via transcription regulators can the activity of antioxidant proteins be influenced by translational regulation and posttranslational modifications like the N-terminal acetylation of alkyl hydroperoxide Ahp1 (Polevoda *et al.*, 1999).

Malfunctioning of antioxidant proteins gives oxygen radicals the chance to alter all kinds of cellular constituents like lipids, proteins and nucleotides. One of the biggest threats to cells is DNA damage, because if it is not repaired it will be passed on to the next generation. Therefore defences against this type of damage are very stringent. Even a single double-strand break can lead to cell cycle arrest (Huang *et al.*, 1996). Oxidative stress can cause these kinds of damage but with different consequences in different phases of the cell cycle. During S-phase the DNA gets duplicated for which it has to be unwound from the histones making the structure more 'open' and vulnerable to oxygen radicals. It is therefore hypothesized that during S-phase, cells could require increased levels of antioxidant proteins. Examples of differences in sensitivity during the cell cycle are known, for instance the sensitivity of mitotic CHO cells to hydrogen peroxide, which is larger than that of G1-phase cells (Martinez Munoz *et al.*, 2002). However, in this case it does not involve DNA damage but an inhibition of the breakdown of one of the cyclins. This example underlines that there are complicated ways of regulating cell cycle progression and stress response. It is

a waste of resources to keep up the defences when radical levels are low or absent. Moreover, as mentioned above, also during the cell cycle there are periods when the cells are less sensitive to oxygen radicals. Thus, there has to be a balance between investing energy in antioxidant defences and using these resources for other purposes like growth.

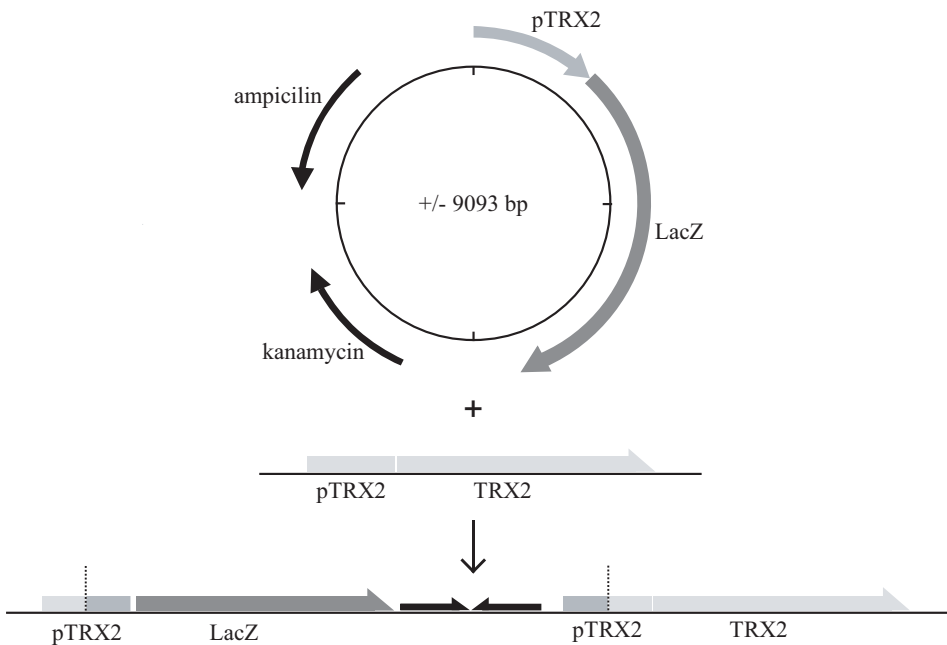
To be able to measure antioxidant responses to oxidative stress, a reporterconstruct was devised. This was made by amplifying the *TRX2* promoter sequence and ligating it into a *LACZ* containing plasmid. By homologous recombination it was transformed into the wild-type yeast strain. To investigate the responses to oxidative stress during the cell cycle, cells were synchronized by centrifugal elutriation (Silljé *et al.*, 1997). One of the advantages of this method is that cells are not forced into a certain phase like with the  $\alpha$ -factor arrest method or the Cdc25 temperature sensitive mutants, but cells in the same phase are selected from a heterogeneous population.

In this study we investigated the response of the constructed reporterstrain to exposure to oxidative stress during the cell cycle to find out whether expression of proteins are cell cycle dependent. The reporterconstruct does not show any variations in expression during the cell cycle when no oxidants are present. However, there is a cell cycle dependent variation in the response of the reporterconstruct when the cells were challenged with a rather low concentration of 0.1 mM hydrogen peroxide. The upregulation of the reporterconstruct is only apparent when the cells are in S-phase. However, isolated mRNA showed that *TRX2* mRNA levels were not affected by the phase of the cell cycle; they showed continuous induction. Measured rates of protein synthesis show low levels during early G1. These low levels are probably the reason for the low expression of LacZ after exposure to stress during G1.

## Materials and Methods:

### Strains and growth conditions:

In all experiments the wildtype strain CEN-PK113-7D (*MATa SUC2 MAL2-8c MEL*) also known as VWk43 was used. To construct the reporterplasmid, the TRX2 promoter region was amplified from CEN-PK102-3A (*MATa SUC2 MAL2-8c MEL ura3 leu2*) or VWk18 chromosomal DNA with primers TRXL-MV (5'-GCGGGATCCTGACACCAAAGCTGTAC-3') and TRXR-MV (5'-GCGCCCGGGCATTATTGATGTGTTATTTAAAG-3'). This PCR fragment was cloned into pFA6a-lacZMX3 after a BamHI/XmaI digestion resulting in pUR5881. After BstEII partial linearization this plasmid was integrated into yeast chromosomal DNA of VWk43 resulting in VWk43-pTRX2-β-gal (pUR5881) hereafter referred to as VWk43pTRX. The endogenous *TRX2* sequence was not disturbed as the construct integrates in front of the gene (see figure 4.1). Cultures were grown at 30°C in a rotary shaker at 180 rpm in Yeast Nitrogen Based medium (YNB, Difco) with 1-2 % glucose or galactose as indicated.



**Figure 4.1:** The *TRX2*-promoter construct. The construct was cut open at the promoter site and then integrated into the genomic DNA. Note that the endogenous *TRX2* gene including its promoter is not disturbed by this integration.

### **$\beta$ -galactosidase assay:**

Yeast cells were grown at 30°C after which they were or were not exposed to hydrogen peroxide.  $\beta$ -Galactosidase assays were essentially performed as described in Maniatis (Sambrook *et al.*, 1989) with modifications. Triple samples of each 150  $\mu$ l were taken and added to a 96-multiwellplate with V-shaped wells. This plate was kept at -20°C. After sampling the plate was slowly thawed at 0°C after which the cells were spun down and the supernatant was discarded. To each well 20  $\mu$ l of 0.05 % Triton X-100 in 0.1 M Tris pH 7.5 was added and the samples were frozen to -80°C to ensure lysis of the cells. After defrosting 80  $\mu$ l of Z-buffer (60 mM Na<sub>2</sub>HPO<sub>4</sub>, 40 mM NaH<sub>2</sub>PO<sub>4</sub>, 10 mM KCl, 1 mM MgSO<sub>4</sub>, 0.25 mM DTT) and 20  $\mu$ l of 1 mg/ml o-nitro-phenyl- $\beta$ -galactopyranoside (Sigma-Aldrich Chemie B.V., Zwijndrecht, Netherlands) in 0.1 M KH<sub>2</sub>PO<sub>4</sub>/K<sub>2</sub>HPO<sub>4</sub> (pH 7) was added. The reaction was stopped by addition of 50  $\mu$ l of 1 M Na<sub>2</sub>CO<sub>3</sub>. The plate was then spun down, the supernatant was transferred to a flat bottom multiwellplate and the cell debris was resuspended in 150  $\mu$ l PBS and also transferred to a flat bottom multiwellplate. The supernatant was measured in a multiwellreader at 415 nm and the resuspended debris was measured at 655 nm.

### **Centrifugal elutriation:**

Centrifugal elutriation was performed as described by Silljé *et al.* (Silljé *et al.*, 1997) with modifications. Cells were grown in 1 litre of YNB with 1 % galactose at 30°C until they reached an OD600 of 2.0. The cells were harvested in a centrifuge at room temperature and sonicated twice for 20 seconds while kept on ice to remove cell clumps. They were loaded into an elutriator spinning at 2000 rpm (Beckman J-6 MI, Mijdrecht, Beckman Coulter Netherlands) with a 40 ml chamber kept at 30°C. Using a Masterflex pump from Cole-Parmer (Aplikon, Schiedam, Netherlands) YNB medium containing 1 % galactose was pumped into the chamber, washing away the newly formed daughter cells, which were subsequently collected on ice. After centrifuging, these were kept overnight in YNB 1 % galactose on ice. After refreshing the medium and transferring cells to a 30°C rotational shaker, their progression through the cell cycle was followed in time by monitoring their budding percentages. This was done by counting buds of at least 100 cells per timepoint.



### **mRNA isolation and Northern blotting:**

mRNA was isolated using a phenol/chloroform extraction as described in Maniatis (Sambrook *et al.*, 1989) with modifications. Samples of 10 ml were quickly frozen by immersion in liquid nitrogen. After slowly thawing the cells and washing them with 1 ml extraction buffer (100 mM Tris-HCl, 100 mM LiCl, 10 mM EDTA), cells were resuspended in 0.5 ml vortex buffer (100 mM LiCl, 10 mM EDTA, 0.5 % LithiumDodecylsulphate, pH 4 with LiOH). Vigorous shaking with 0.45 mm glass beads in a bead-beater (Biospec products) disrupted cell walls and membranes after which a phenol chloroform extraction was performed. After addition of 50 µl 3 M NaAc and 1.25 ml ice-cold ethanol, the mRNA was precipitated at -80°C, samples were centrifuged, washed with cold ethanol (70 %), air-dried and resuspended in water.

mRNA was separated as described by Maniatis (Sambrook *et al.*, 1989) with some modifications. 10 µg of total RNA sample was loaded on a 1 % denaturing formamide/formaldehyde gel and RNA was separated by electrophoresis. RNA was transferred to Hybond-N membrane (Amersham Biosciences, Roosendaal, Netherlands) and cross-linked using UV light in a UV stratalinker (Stratagene Europe, Amsterdam, Netherlands). 15 pmol of oligonucleotides that recognize *TRX2* (5'-TGTCGTATTCAGAAGCGGATTTTA-3') and *ACT1* (5'-TGTCTTGGTCTACCGACGATAGATGGGAAG-3') ordered at Gibco BRL (Invitrogen, Breda, Netherlands) were labelled with T4 polynucleotide kinase (USB, Amersham Biosciences) and 50 µCi  $\gamma$ -<sup>32</sup>P-ATP (Amersham Biosciences) and purified using the QIAquick nucleotide removal kit (Qiagen, Westburg, Leusden, Netherlands). The blots were washed once in 2xSSC (0.3 M NaCl, and 30 mM Na-citrate, pH 7.0) at room temperature, incubated for prehybridization in hybridization mixture (1 mM EDTA, 7 % SDS, 0.5 M NaPO<sub>4</sub> pH 7.5) for at least one hour at 45°C in a micro-4 hybridization incubator (Biozym, Hessisch Oldendorf, Germany). Labelled and purified oligonucleotides were added and hybridized overnight at 45°C. After hybridization the blots were washed with 2xSSC and 0.1 % SDS until background radiation was minimized. Filters were wrapped in Saran wrap (Dow Benelux B.V., Terneuzen, Netherlands) and subsequently placed against a phosphor imager screen (Molecular Dynamics, Sunnyvale, CA, USA) that was scanned after at least 12 hours of exposure.

### **Fed-batch experiments:**

Fed-batch experiments were conducted as described by Silljé *et al.* (Silljé *et al.*, 1997). Synchronous cells were spun down and resuspended in YNB without carbon sources. A Masterflex pump (Cole Parmer) was used to administer galactose at a preset rate. In this way controlled amounts of galactose were added to the cells, typically in the order of 10-20 fmol per cell per hour.

### **Incorporation of <sup>35</sup>S-methionine/cysteine experiments:**

Cells were grown to an OD<sub>600</sub> of 1 in YNB minimal medium with 20 µg/ml methionine and 10 µl/ml cysteine. 1.7 ml of this yeast suspension was transferred to a small glass vessel of 2 ml. Cells were kept in suspension by using a small magnetic stirrer inside the vessel. 17 µl of Redivue PRO-MIX (Amersham Biosciences) was added containing <sup>35</sup>S labelled methionine and cysteine (ratio 70:30) with a specific activity of 1000 Ci/mmol and a concentration of 10 mCi/ml with respect to the methionine. At t=0, cells were transferred to 30°C and the label was added. Every 15 minutes a 100 µl sample was transferred to another culture vessel and 2 µl of 0.1 mM hydrogen peroxide was added. These cells were incubated for 30 minutes after which 5 µl of the sample was spotted on a small piece of Whatman filter that was subsequently dropped in 5 % TCA (trichloro acetic acid) solution with 20 µg/ml methionine and 10 µl/ml cysteine. Also 5 µl samples of the cells that were not incubated with hydrogen peroxide were spotted on Whatman filter and dropped in the TCA. At the end of the time series, the TCA solution was boiled for 2 minutes and replaced by fresh 5 % TCA with the 20 µg/ml methionine and 10 µl/ml cysteine. This solution was boiled again for 2 minutes after which it was washed twice with cold 5 % TCA and twice with ethanol. The filters were then dried, collected in scintillation tubes with scintillation fluid and counted with a scintillation counter. Parallel to this experiment 1.7 ml of yeast suspension received the same treatment without adding the radioactive mix. At each timepoint 50 µl of these cells were transferred to eppendorf tubes containing already 12.5 µl of 1.25 % formaldehyde. These cells were used to determine budding percentages and cell size parameters.

### **Cell viability:**

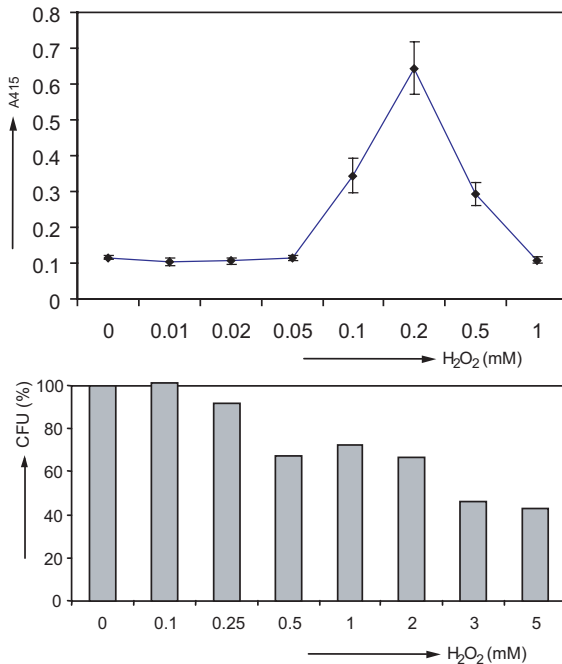
Experiments were conducted to establish the effect of different hydrogen peroxide concentrations on survival rates. Cell cultures were grown to an OD<sub>600</sub> of 1

after which they were subjected to different concentrations of hydrogen peroxide for half an hour. Cells were diluted 10.000 times (2 times 100 fold) after which 100  $\mu$ l was plated on YPD plates containing 1 % glucose. The plates were incubated at 30°C for 3 to 4 days after which colonies were counted.

## Results:

### Effect of hydrogen peroxide on cell viability

Transformed cells were exposed to different concentrations of hydrogen peroxide after which expression of the reporterconstruct and the amount of Colony Forming Units (CFU's) were determined. As shown in figure 4.2, expression started at 0.1 mM hydrogen peroxide increasing at 0.2 mM after which it dropped again. The CFU counts (see figure 4.2) show that at hydrogen peroxide concentrations of 0.25 mM and higher, viability is impaired and keeps decreasing until only 50 % is viable when exposed to 5 mM of hydrogen peroxide. This decrease in viability probably explains the drop in expression of the reporterconstruct at higher hydrogen peroxide concentrations. It was concluded that incubation of 30 min with 0.1 mM hydrogen peroxide was sufficient to induce significant expression without impairing cell viability.

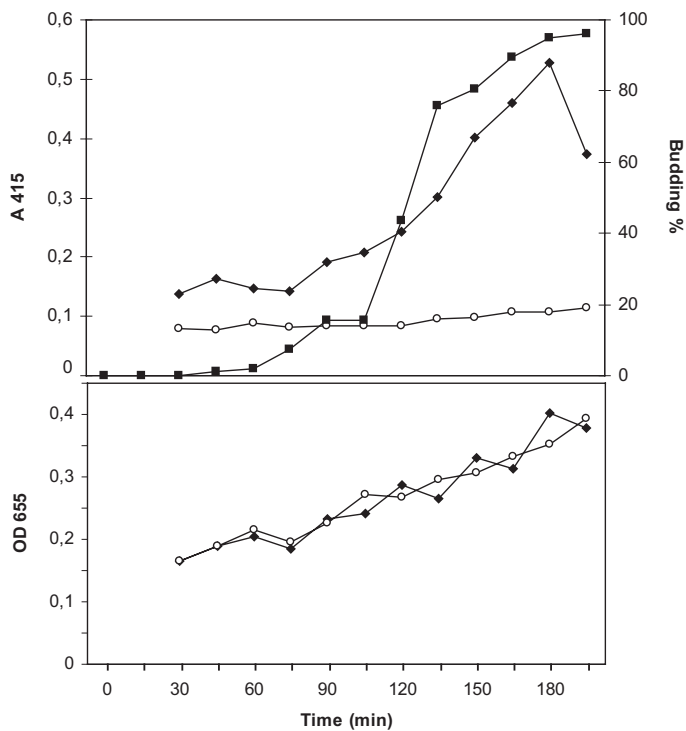


**Figure 4.2:** Determining optimal exposure conditions of hydrogen peroxide to our transformed cells. Exposing the vw43 pTRX cells to different concentrations of hydrogen peroxide showed increased expression of  $\beta$ -galactosidase (upper graph) but also a decrease in viable cells (lower graph).

### Expression of *TRX2*-promoter construct during the cell cycle with and without exposing to hydrogen peroxide

Synchronous cells were isolated from an exponentially growing population by elutriation. Expression of the reporterconstruct was followed in time while the cells progressed through the cell cycle. The progression of the cell cycle was monitored by

determining budding percentages. Budding started at 75 minutes and reached a maximum of 95% at 195 minutes. The end of G1, and therefore also the start of S-phase was defined as 50% of the maximum budding percentage, in this case around 120 minutes (figure 4.3). Each 15 minutes, samples were taken that were exposed to 0.1 mM hydrogen peroxide for 30 minutes. Expression of the reporterconstruct was followed by measuring optical density at 415 nm while the growth was monitored by measuring OD 655. As shown in figure 4.3, the cells which did not receive hydrogen peroxide treatment expressed constant low levels of  $\beta$ -galactosidase and hence of Trx2. However, the cells exposed to hydrogen peroxide show a strong increase in expression of  $\beta$ -



**Figure 4.3:** Induction of the reporterconstruct during the cell cycle. Every 15 minutes a sample was taken which was stimulated with 0.1 mM hydrogen peroxide (◆) or without hydrogen peroxide (○) for 30 minutes after which expression of lacZ was determined (A415). Cell cycle progression was monitored by determining budding percentages (■) and measuring the optical density at 655 nm. Expression of lacZ remains rather constant until cells enter S-phase after which it increases fast.

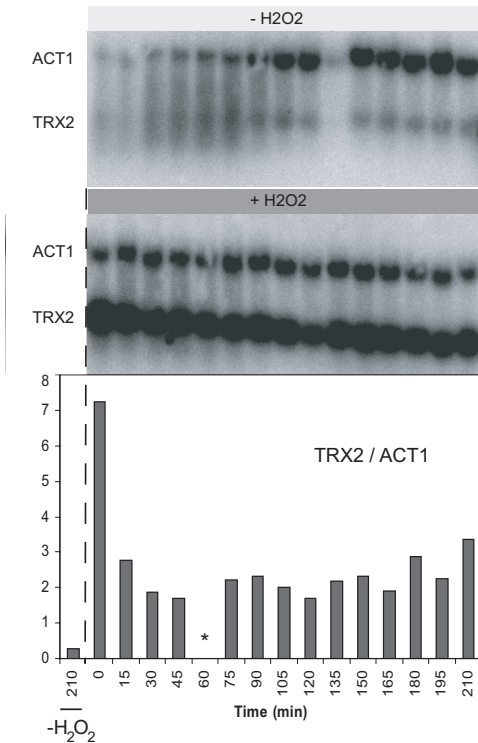
galactosidase after 75 minutes, so after the budding percentages started to rise. It is also observed by measuring the levels of the OD 655 that growth is not impaired by 30-

minute exposure to hydrogen peroxide. The expression of *TRX2* is higher during S-phase than during G1 after exposing to stress.

**Expression of *TRX2* mRNA during the cell cycle with and without exposing to stress**

To elucidate whether the regulation of *TRX2* expression was at transcriptional or at translational level, mRNA was isolated from cells progressing through the cell cycle with and without a 30-minute exposure to hydrogen peroxide as described above. Probes against the *TRX2* gene were hybridized with northern blots containing these mRNA samples. The upper bands in figure 4.4 are the actin loading controls and the lower bands are the *TRX2* bands. The *TRX2* bands are virtually absent in the cells that are not exposed to hydrogen peroxide and they are strongly induced in the samples that did receive hydrogen peroxide treatment. The ratio between the thioredoxin transcript levels and the actin levels shows, apart from the first timepoint, a constant value (lower part of figure 4.4). This indicates that the *TRX2* gene gets induced equally at every

timepoint during the cell cycle when exposed to hydrogen peroxide. The earlier observed S-phase specific upregulation of the reporterconstruct therefore is regulated at a later stage, at translational or posttranslational level.

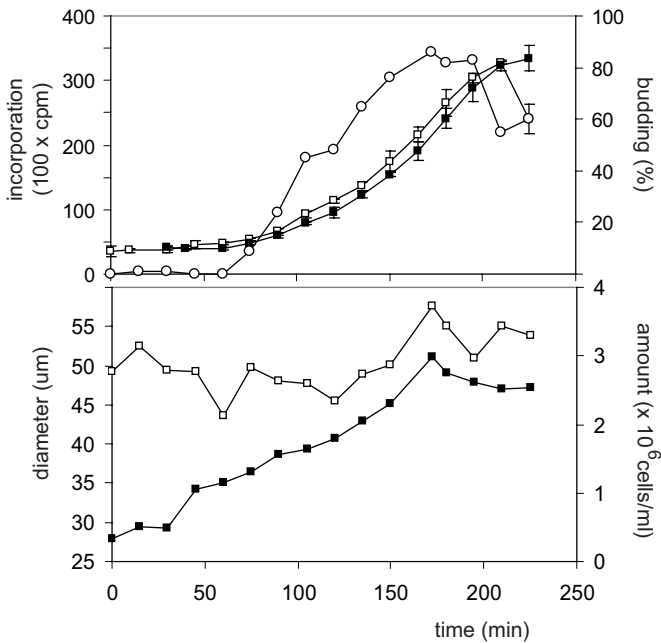


**Figure 4.4:** Expression levels of *TRX2* mRNA. On the upper blot are the samples without hydrogen peroxide exposure while on the second blot the samples are shown that were exposed to hydrogen peroxide. In the lower graph are the ratios depicted of the *TRX2* mRNA divided by the actin signal. After stimulation with 0.1 mM hydrogen peroxide the levels of *TRX2* mRNA do not seem to be influenced by the progression through the cell cycle. (\* not quantifiable)

### Protein synthesis rates during the cell cycle

The expression of the reporterconstruct and the induction of *TRX2* mRNA do not show the same behaviour. These contrasting data can only be explained if the LacZ protein is translational or posttranslational regulated. In order to establish whether there is a general translational effect on protein levels during the cell cycle, experiments were conducted to determine protein synthesis rates in synchronous cells progressing through the cell cycle with and without exposure to hydrogen peroxide. Protein synthesis rates were determined by measuring incorporation of <sup>35</sup>S labelled methionine and cysteine. Synchronous cells were obtained by centrifugal elutriation. After addition of labelled methionine and cysteine, every 15 minutes samples were taken and exposed to 0.1 mM hydrogen peroxide for 30 minutes.

The cells progress normally through the cell cycle as is visualized by the budding profile in the upper graph (figure 4.5 upper graph). Budding starts at 75 minutes and



**Figure 4.5:** In the upper graph the incorporation of <sup>35</sup>S labelled Met/Cys is increasing in time (□). The samples of the cultures treated with 0.1 mM hydrogen peroxide exhibit a slightly lower signal (■). In the same graph also the budding profile is depicted with its corresponding axis on the right (○). In the lower graph the amount of cells (□) and the mean (■) diameter of these cells against the time are visualized.

increases up to 90% around 170 minutes, which determines that S-phase starts at 105 minutes. Cell diameter gradually increases up to a maximum of 50 µm at 170 minutes

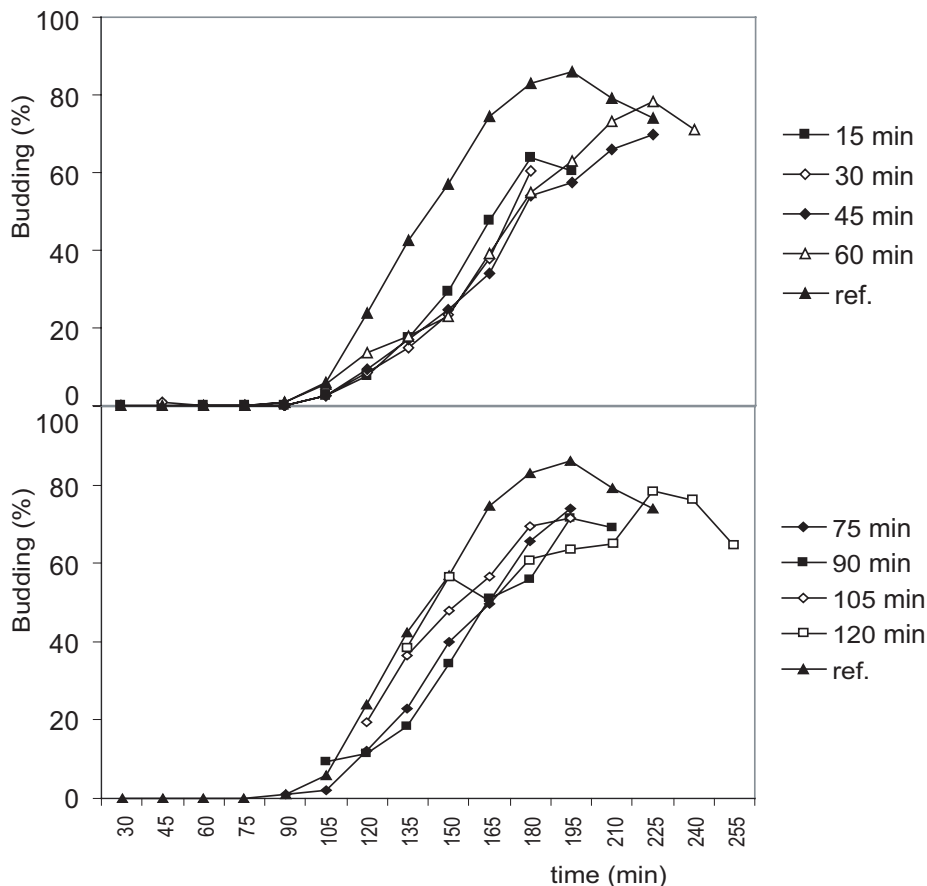
while the amount of cells stays constant, showing that growth is normal (figure 4.5 lower graph). The incorporation of  $^{35}\text{S}$ -labeled methionine and cysteine in the samples without hydrogen peroxide stays at background levels until 45 minutes and then it gradually increases. After the budding starts to increase also the incorporation of label increases faster and when the budding decreases again at 180 minutes also the incorporation slows down. These results indicate that during early G1 general protein synthesis is low, both in the cells that are exposed to hydrogen peroxide and in the control cells. Only when cells enter S-phase at 105 minutes incorporation of radioactive label is measured.

The samples exposed to hydrogen peroxide show only a slight decrease in incorporation compared to the control cells but the same trend is visible. This implies that adding 0.1 mM hydrogen peroxide does not severely impair protein synthesis.

### **Effects of hydrogen peroxide during the cell cycle on growth and cell cycle progression**

As stated above, the S-phase specific upregulation of the reporterconstruct is regulated at translational level because a general low level of protein synthesis is observed in G1-phase. There is a small decrease in general protein synthesis when the cells are exposed to hydrogen peroxide. This effect should therefore also influence general cell growth and progression through the cell cycle. To investigate this, synchronous cells were isolated by centrifugal elutriation and continuously exposed to 0.1 mM hydrogen peroxide from different timepoints within the cell cycle after which their budding profile was followed. This revealed that, stimulation during the first 90 minutes led to a delay in cell cycle progression of at least 30 to 45 minutes. However, cells exposed at 105 and 120 minutes were not or only minor influenced during the following 45 minutes (see figure 4.6). Apparently, hydrogen peroxide causes more delay in cell cycle progression during G1 than during S-phase. This is even more clearly shown when the cells were exposed to 1 mM hydrogen peroxide instead of 0.1 mM. Synchronous cells were grown and exposed to 1 mM hydrogen peroxide from timepoint 0, 30, 60 and 90 minutes. Budding profiles revealed that cells exposed from timepoint 0 minutes were only slowly progressing through the cycle, its budding percentage gradually increasing up to of 60 % after 210 minutes. Exposing as from 30 minutes leads to a maximum at 85% after 180 minutes, from 60 and 90 minutes, maximums are



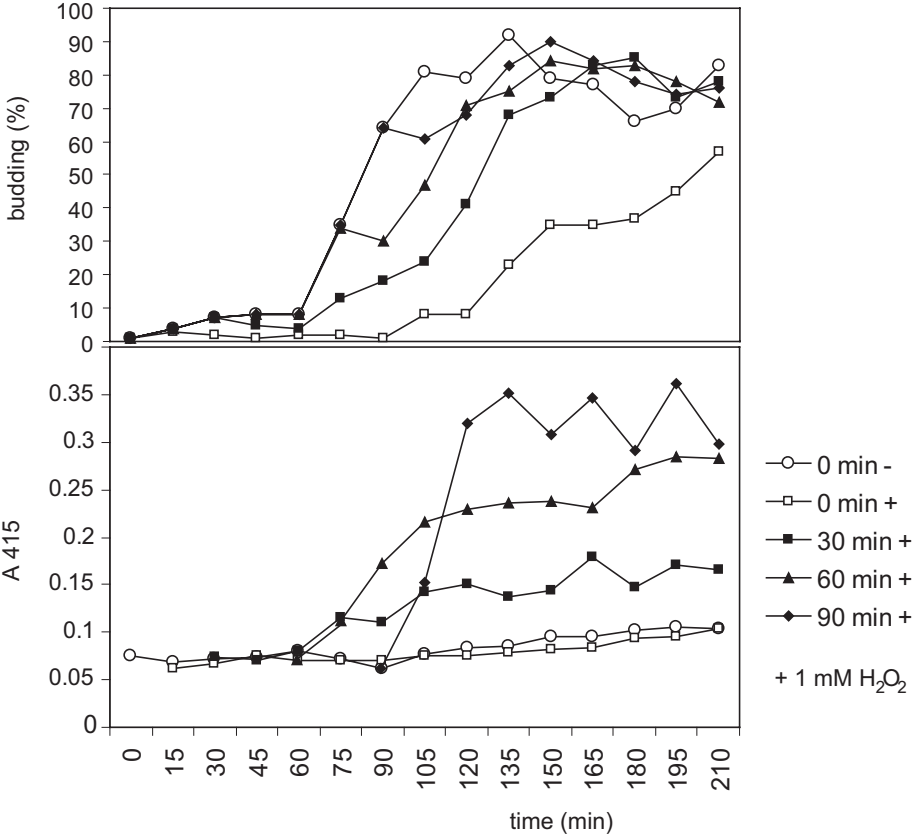


**Figure 4.6:** The influence of 0.1 mM hydrogen peroxide on progression through the cell cycle. Continuous stimulation with hydrogen peroxide of synchronous cells, starting at different timepoints, in the upper graph: ■: 15 min, ◇: 30 min, ◆: 45 min, △: 60 min, ▲: reference without hydrogen peroxide and in the lower graph: ◆: 75 min, ■: 90 min, ◇: 105 min, □: 120 min, ▲: reference without hydrogen peroxide. Samples 105 and 120 min. show less deviation of the reference budding profile than other timepoints.

more than 90 % at 135 and 150 minutes respectively (figure 4.7). The phase of the cell cycle is influencing the stress response.

In figure 4.7 there is shown that there is absolutely no difference in expression of the reporterconstruct between cells exposed with or without hydrogen peroxide from timepoint 0, they both do not express the reporter. The cells exposed after 30 minutes show induction of the reporter but only as from 75 minutes while the samples exposed after 60 minutes show a direct increase in signal, which becomes almost twice as much

compared to the 30-minute sample. Expression of the reporter in the 90-minute samples reaches almost three times as much expression as in the 30-minute sample. Apparently, cells in G1 respond less to stress. On the contrary, cells that have reached S-phase do respond to external oxidative challenges. In fact, the further the cells progress from G1, the better the stress response. Also the effect on the budding profiles of the different samples is clear. Cells exposed from the start of G1 are more sensitive to hydrogen peroxide and rather reluctant to go through the cell cycle, whilst cells already progressing seem to be less influenced. This is in line with earlier conclusion that cells in G1 are not able to respond to external challenges because protein synthesis rates are low.



**Figure 4.7:** Protein synthesis as a function of cell cycle progression. Continuous exposure to 1 mM of hydrogen peroxide, starting at different timepoints during the cell cycle leads to different responses. Upper graph represents the budding profile of the different samples while the lower graph shows the expression of the  $\beta$ -galactosidase reporterconstruct. Reference cells without hydrogen peroxide (○), cells stimulated from the start (□), cells stimulated from 30 min. (■), from 60 (▲) and from 90 min. (◆).

## Discussion:

Because DNA damage is a major threat to the cell, measures have to be taken to minimize the occurrence of this damage. During the cell cycle the DNA is unwound and duplicated during S-phase at which time point it is potentially very vulnerable to external challenges like oxygen radicals. It is therefore expected that the regulation of the defences against these radicals is not only stress dependent but also cell cycle dependent.

To monitor the expression of antioxidant proteins a reporterconstruct was made consisting of a *TRX2*-promoter in front of a *LACZ* gene. Using synchronous cells it was measured that expression of this reporterconstruct showed no fluctuations during the cell cycle. However, when the expression of this reporterconstruct was monitored in growing synchronous cells while at the same time exposed to hydrogen peroxide it was shown that after the budding increased, so during S-phase, the expression of the reporterconstruct increased. However, when the levels of *TRX2* mRNA were measured, it showed constitutive expression of *TRX2* after stimulation with hydrogen peroxide regardless the phase of the cell cycle. Therefore the S-phase specific upregulation is not regulated at the transcriptional level but at translational or posttranslational level.

To investigate this, <sup>35</sup>S-labeled cysteine and methionine were added to the cells to measure the rate of protein synthesis as function of the cell cycle and stress exposure. This revealed that protein synthesis rates during G1 are low, both in the samples with and without hydrogen peroxide. This explains why there is no LacZ protein after exposure to hydrogen peroxide in G1. Thus, the regulation of the expression of LacZ is at translational level.

The exposure to hydrogen peroxide results in a small decrease in protein synthesis rates. However this decrease should not only influence LacZ but should also delay synthesis of other proteins. This delay should lead then to a slowing down of progression. This was investigated by closely monitoring progression through the cell cycle after continuous exposure to 0.1 mM hydrogen peroxide starting at different timepoints. It does show that during the first 90 minutes, cells experience a delay in progression through the cycle, but when exposed from 105 and 120 minutes cells appear only slightly influenced by it. If a higher concentration of hydrogen peroxide was used

(1 mM) it was observed that both cell cycle progression and reporterconstruct expression are impaired when the exposure starts when the cells are in G1.

Why is the protein synthesis rate so low in the first stages of the cell cycle? A synchronous population of cells consists of small and newly synthesized daughter cells, which have to grow and reach a critical cell size in order to be able to finish a complete cell cycle (Hartwell *et al.*, 1974). Quiescent cells have < 25 % of ribosomes compared to an exponentially growing cell. However, what this ratio is in daughter cells compared to mother cells is not known yet. The protein synthesizing machinery, the ribosomes, have recently been linked to both cell growth and cell division by the observation that specific mutations in ribosome biogenesis pathways led to the uncoupling of growth from division (Jorgensen *et al.*, 2002; Verrips, 2003). The microarray analysis performed by Spellman *et al.* showed that in synchronous cultures, no significant changes were observed regarding the expression of ribosomal proteins (Spellman *et al.*, 1998). How exactly ribosome biogenesis is regulated during the cell cycle is not known yet.

Our experiments indicate that possibly small G1-phase cells have low amounts of ribosomes. First, new ribosomes have to be synthesized and after this has taken place, protein synthesis can increase. This explains the apparent contradicting results between protein levels and mRNA levels. However, this means that the increase in expression of the promoterconstruct is not a specific response to stress. It is merely the absence of sufficient protein synthesizing capacity that is the reason for this S-phase specific upregulation. However, cell cycle progression is delayed when cells are exposed to hydrogen peroxide from timepoint zero. This could be a mechanism that prevents S-phase to start if conditions are not favourable. It is known that hydrogen peroxide can cause cell cycle arrest at G2 (Flattery-O'Brien and Dawes, 1998) but the data presented here indicate a possible other checkpoint in G1.

### **Acknowledgements:**

I'd like to thank Anne Marie Verbiest for constructing the reporter plasmid.

5

*A*ged yeast cells show a specific decrease in response to oxidative stress

**Abstract:**

There appears to be a clear link between aging and oxidative stress. However whether the oxidative stress defences are weakened during aging is not established yet. To elucidate whether there are differences in expression of antioxidant genes in old versus young cells and whether defences against oxidative stress in old yeast cells are more responsive to hydrogen peroxide, mRNA was isolated from young and old cells with and without exposure to 0.1 mM hydrogen peroxide. After translation of the mRNA into radioactively labelled cDNA, microarray experiments were conducted. This revealed that several of the components of the thioredoxin system namely *TRX1*, *TRR1*, *TSA1*, *AHP1* and *PRX1* are less expressed in old cells than in young cells. Furthermore, *TRX1*, *TRX2*, *TRR1*, *TSA1* and *AHP1* are induced in young cells by hydrogen peroxide but show a smaller induction by hydrogen peroxide in the old cells. This behaviour does not involve changes in viability. Exposure to 0.1 mM hydrogen peroxide does not influence the amount of colony forming units. These observations lead to the assumption that aged cells are less capable of responding to oxidative stress.

## Introduction:

As seen in previous chapters, there is a link between stress response and aging. The accumulation of damage caused by the continuous exposure to oxygen radicals is thought to be a major cause of malfunction and eventually death of the cells. These radicals originate from exogenous sources and from several reactions within the cell itself. The stepwise reduction of molecular oxygen to water in the mitochondria produces a permanent flow of oxygen radicals. This is not the only site where oxygen radicals are produced, also the  $\beta$ -oxidation of fatty acids in the peroxisomes leads to formation of reactive oxygen species (ROS). Damage caused to DNA is very detrimental to the cell, however it is not clear whether that is really one of the aspects of aging. In *Saccharomyces cerevisiae* DNA damage should be passed on to daughter cells, however daughter cells frequently display full replicative lifespan (Kennedy *et al.*, 1994). Then again, there are a lot of other cellular constituents that can be damaged like proteins and lipids.

To counterattack these ROS, the cell has obtained several defence mechanisms. The glutathione system, the thioredoxin system, the catalases, the superoxide dismutases and small antioxidant molecules like vitamin C and E that can scavenge all kinds of radical species. The glutathione system consists of two synthetases Gsh1 and Gsh2 responsible for the synthesis of the tripeptide glutathione (GSH) (Ohtake and Yabuuchi, 1991), three glutathione peroxidases Gpx1, Gpx2 and Hyr1 involved in oxidation of GSH (Inoue *et al.*, 1999), a glutathione reductase Glr1 involved in reduction of oxidized GSH (Grant *et al.*, 1996b) and five glutaredoxins, Grx1, Trx1, Grx3, Grx4 and Grx5 either involved in reducing oxidized GSH or functioning as GSH dependent reductases (Collinson *et al.*, 2002; Shenton *et al.*, 2002). The thioredoxin system has similar components, three thioredoxins, Trx1, Trx2 and Trx3 functioning as the reducing equivalents for the thiolperoxidases Tsa1, Tsa2, Prx1, Ahp1 and Dot5 (Pedrajas *et al.*, 1999; Park *et al.*, 2000). In addition there exist thioredoxin reductases Trr1 and Trr2 taking care of reducing oxidized thioredoxins at the expense of NADPH (Pedrajas *et al.*, 1999; Kumar *et al.*, 2002). The catalases Ctt1 and Cta1 both convert hydrogenperoxide directly to water and oxygen (Grant *et al.*, 1998) while the superoxidisedismutases convert superoxide radicals to hydrogen peroxide (Fridovich, 1975; Hart *et al.*, 1999).

It has been published that glutathione content and superoxide dismutase activity decrease in aging yeast cells (Grzelak *et al.*, 2001) although it is not clear whether this has a detrimental effect on the cell's viability. It is clear however that in some cases increasing antioxidant systems in other modelorganisms like *Drosophila melanogaster* and *Caenorhabditis elegans* can extend lifespan (Orr and Sohal, 1994; Melov *et al.*, 2000).

*Saccharomyces cerevisiae* is a budding yeast of which the daughter cell is smaller than the mother cell. If a survival curve is plotted as function of the amount of divisions a curve is revealed that shows an increasing age-specific mortality, which by definition is a hallmark of aging. Besides the increase in mortality also other phenotypic differences are observed like surface wrinkles and fragmentation of the nucleolus. The difference in size makes it possible to separate the daughter cell from the mother cell. In the early days this happened on a small scale by micromanipulation but nowadays it is possible to use sucrose gradient centrifugation and elutriation for large-scale isolations. The earlier mentioned observed decrease in glutathione content was measured in old cells, which were treated rather rough, including Percoll gradient centrifugation, sonication and shaking with glass beads (Grzelak *et al.*, 2001). This will have large influences on stress responses, which will interfere with the 'normal' stress response of old cells. To be able to investigate stress response of old cells compared to young cells a suitable and gentle method has to be used. This was found in centrifugal elutriation.

In the literature there have been several methods described to isolate old yeast cells on a large scale. Sucrose gradient (10-30% sucrose) centrifugation at 4°C (Egilmez *et al.*, 1990), a 'baby machine' in which a culture of yeast cells was immobilized on a poly-D-lysine coated membrane continuously budding of daughter cells (Helmstetter, 1991), using biotinylated cells and streptavidin coated magnetic beads to sort old cells from a population of growing cells (Smeal *et al.*, 1996), stepwise elutriation at 4°C to obtain only the fraction with the largest cells and thus oldest cells (Laun *et al.*, 2001) and continuous centrifugal elutriation (Woldringh *et al.*, 1995). Of these methods above the method using centrifugal elutriation by Woldringh *et al.* is the most elaborate but at the same time probably the method that influences the cells the least (Woldringh *et al.*, 1995). A chamber loaded with a culture of yeast cells was centrifuged while fresh medium was constantly pumped into the chamber washing away all the small newly



formed daughter cells. By keeping the whole system at 30°C, cells could be kept dividing for extensive periods of time.

To obtain old yeast cells both the methods with the magnetic beads and the ‘baby machine’ were tested but these methods were not successful. The method described by Woldringh *et al.* did result in a population enriched in old cells. Exposure to 0.1 mM of hydrogen peroxide did not lead to differences in viability between the old and the young cells. However, there were several differences concerning transcriptional stress response. It appeared that several genes of the thioredoxin system are expressed at lower levels in old cells than in young. Besides, these antioxidant genes are also less responsive in the old cells exposed to hydrogen peroxide. This confirms the hypothesis that old cells are less capable of dealing with oxidative stress.

## Materials and Methods:

### Strains and growth conditions:

In all experiments the wildtype strain CEN-PK113-7D (*MATa SUC2 MAL2-8c MEL*) also known as VWk43 was used. Cultures were grown at 30°C in a rotary shaker at 180 rpm in Yeast Nitrogen Based medium w/o amino acids (YNB, Difco, Detroit, USA) with 1-2 % glucose or galactose as indicated.

### Obtaining old yeast cells:

Old yeast cells were obtained essentially as described by Woldringh *et al.* (Woldringh *et al.*, 1995) with some modifications. Cells were inoculated in 200 ml of YNB (Difco, Detroit, USA) containing 1 % glucose and grown until they reached stationary phase. Cells were centrifuged at room temperature, collected and sonicated twice for 20 seconds to loose cell clumps. Cells were loaded into an elutriator spinning at 2000 rpm (Beckman J-6 MI, Mijdrecht, Beckman Coulter Netherlands) with a 40 ml chamber kept at 30°C. Using a Masterflex pump from Cole-Parmer (Aplikon, Schiedam, Netherlands) YNB medium containing 1 % glucose was pumped into the chamber, washing away the newly formed daughter cells. The pump speed was set at 2.7 litre medium per hour. The cells were kept growing for 30 hours after which a control population of daughter cells were collected from the flow-through. The elutriator was stopped and the fraction remaining in the chamber was collected containing the 'old' mother cells.

### Determining age by counting budscars

1 mg/ml Calcafluor white M2R, also known as Fluorescent Brightener 28 (Sigma-Aldrich Chemie B.V., Zwijndrecht, Netherlands) was dissolved in YNB (Difco). Calcafluor white does not completely dissolve in YNB, therefore it was centrifuged in a table centrifuge and only the supernatant was used to incubate with the cells for 30 minutes. After washing the cells with PBS, they were observed with a fluorescence microscope.

### **Determining viability after exposing to hydrogen peroxide:**

Old and young cell populations were diluted until they reached an OD<sub>600</sub> of 1. Different concentrations of hydrogen peroxide were added for 30 minutes after which the samples were diluted 10<sup>4</sup> times. 100 µl of cell suspension was plated on YPD plates.

### **mRNA isolation:**

After exposing both the old and the young cells to hydrogen peroxide, mRNA was isolated using a phenol/chloroform extraction as described in Maniatis (Sambrook *et al.*, 1989) with modifications. Samples of 10 ml were quickly frozen by immersion in liquid nitrogen. After slowly thawing the cells and washing them with 1 ml extraction buffer (100 mM Tris-HCl (pH 7.5), 100 mM LiCl, 10 mM EDTA), cells were resuspended in 0.5 ml vortex buffer (100 mM LiCl, 10 mM EDTA, 0.5 % LithiumDodecylsulphate, pH 7.5 with LiOH). Vigorous shaking with 0.45 mm glass beads in a bead-beater (Biospec products, Bartlesville, OK, USA) disrupted cell walls and membranes after which a phenol chloroform extraction was performed. After addition of 50 µl 3 M NaAc and 1.25 ml ice-cold ethanol, the mRNA was precipitated at -80°C, samples were centrifuged, washed with cold ethanol (70 %), air-dried and resuspended in water.

### **Microarray experiments:**

Microarray experiments were conducted as described by Schoondermark-Stolk *et al.* (Schoondermark-Stolk *et al.*, 2002). Isolated pools of transcripts were labelled with radioactive dCTP. This labelling is performed by making cDNA from the isolated mRNA in the presence of radioactively labelled nucleotides. 4 µg of RNA (measured at 260 nm) was mixed with 2 µl of OligodT (1 µg/µl), to a final volume of 10 µl. The following components were added: 6 µl of first strand buffer (Life Technologies, Breda, The Netherlands), 1 µl of 0.1 M dithiothreitol, 1.5 µl of a mixed solution containing 100 mM of dATP, dGTP and dTTP, 300 units of Superscript II reverse transcriptase (Life Technologies) and 100 µCi [<sup>33</sup>P]CTP (Amersham Biosciences, Roosendaal, The Netherlands). The mixture was kept at 37°C for 90 min. after which 70 µl of STE (0.1 M NaCl, 10 mM TRIS.HCL (pH 8.0), 1 mM EDTA (pH 8.0)) was added. The newly synthesized cDNA was subsequently purified by passage through a Sephadex G-50

column (Amersham Biosciences) and washed with 350  $\mu$ l of STE after which it was eluted with 500  $\mu$ l of STE. The cDNA was denatured by heating it to 100°C for 3 min. Yeast GeneFilter microarrays (ResGen, Invitrogen, Breda, The Netherlands) were washed for 5 min. with boiling 0.5 % SDS. The membranes were prehybridized for 4 h with 5 ml MicroHyb solution (ResGen) and 5  $\mu$ l OligodA (ResGen) at 42°C in a roller oven (Thermo Hybaid, Landgraaf, The Netherlands). The labelled cDNA probes were added to these prehybridized filters and incubated over night at 42°C. The next day, the filters were rinsed with 2xSSC (diluted from 20xSSC which contains: 3 M NaCl, and 0.3 M Na-citrate, pH 7.0) and 1 % SDS for 20 minutes at 50°C. This was repeated once, after which an additional rinsing step followed with 0.5xSSC with 1 % SDS for 15 minutes at room temperature. The filters were subsequently transferred to a humid 3-layer Whatman filter, wrapped in Saran foil and placed against a Phosphor screen (Molecular Dynamics, Sunnyvale, CA, USA). After 6 days of exposure the screen was read by a phosphorimager SI (Molecular Dynamics) coupled to a computer.

#### **Data analysis and spot validation:**

Images were scanned at 50- $\mu$ m resolution in Image-Quant 5.1 (Molecular Dynamics) and imported into the ImaGene 4.2 microarray analysis software (BioDiscovery, Marina del Rey, CA, USA). Standard grids were placed over the images of the arrays after which spotsize was fixed at 15 pixels and the autoadjusted spot function was applied. Very intense spots tend to ‘blossom’ out their signal, leading to an increase of signal in surrounding spots. Usually these surrounding spots were ‘flagged’ by hand. Flagged data were not used.

Although ImaGene has various features to quantify background and signal intensities per spot, it was preferred to use local blank spots as background values except when these spots were flagged. In this case the local blank spot of one row ahead was used. All the quantified data were imported into an Excel sheet (Microsoft) after which the identities of the different genes were added. Values used were the signal mean values, which are the total signal values divided by the area.

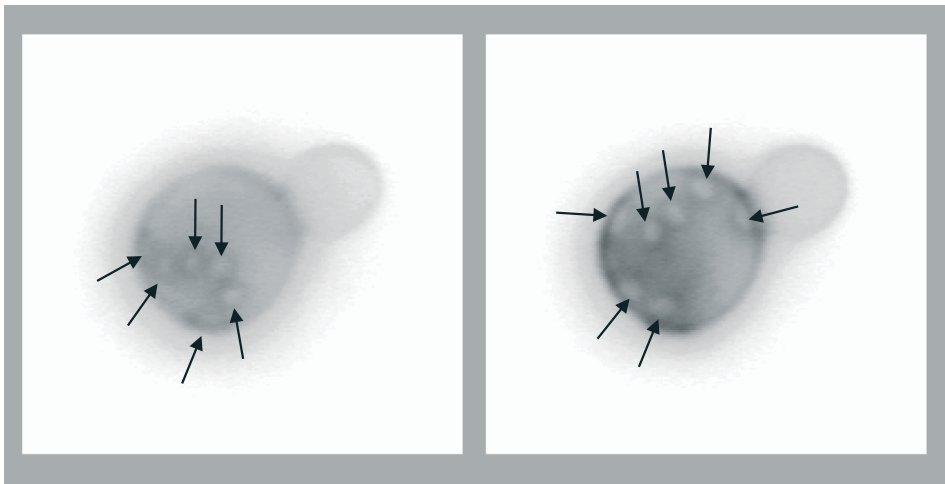
Normalization was usually carried out by dividing the values through the average of all spot intensities.

## Results:

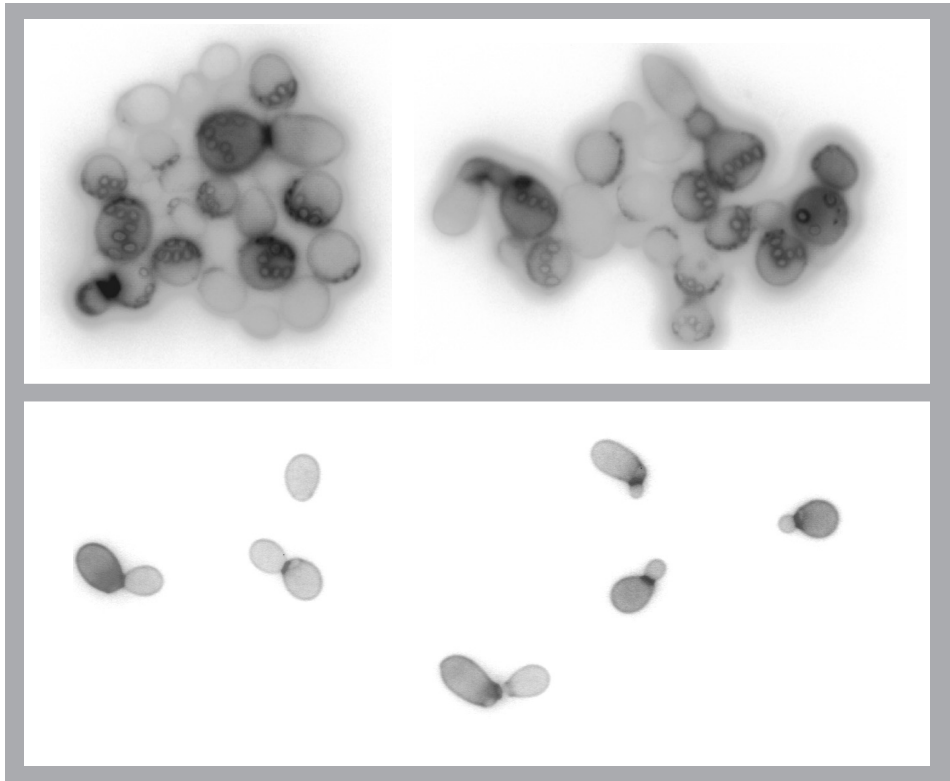
### Sensitivity of old cells to oxidative stress

Several methods were tested to isolate old yeast cells. Both the method described by Helmstetter *et al.* (Helmstetter, 1991) called the ‘baby machine’ and the one published by Smeal *et al.* (Smeal *et al.*, 1996), who used magnetic beads, were not successful. Eventually, old yeast cells were obtained by using centrifugal elutriation described by Woldringh *et al.* (Woldringh *et al.*, 1995). This led to populations, which were enriched in cells with multiple budscars like depicted in figure 5.1. However, the population is heterogeneous with respect to different ages, see figure 5.2. From 20 images, ratios of budded cells vs. non-budded cells were compared, revealing that 50% of the population had on average 7 budscars. A normal growing population contains only 0.8 % cells with 7 budscars. Therefore, the obtained population is older than a normal growing population of yeast cells.

Old and young cells were subjected to 0.1 mM, 1 mM and 10 mM of hydrogen peroxide for 10 minutes after which dilutions were plated on YPD agar. It appeared that incubation with 0.1 mM hydrogen peroxide had no influence on the amount of colony

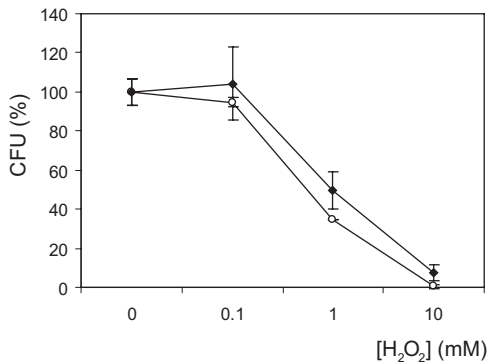


**Figure 5.1:** An old yeast cell of at least the 13<sup>th</sup> generation. Pictures were taken in different focusplanes. The arrows indicate budscars.



**Figure 5.2:** Old populations (upper) show many cells with multiple budscars, vs. young cells (lower) that do not show bud scars.

forming units (CFU's) neither of the old or the young cells (see figure 5.3). Incubation with 1 mM hydrogen peroxide showed a decrease to 50 % (sd 10 %) in the old cells and 35 % (sd 0 %) in the young cells. Exposure to 10 mM hydrogen peroxide led to CFU-counts below 5 %. It seems that the young cells are slightly more sensitive to oxidative stress than the old cells.



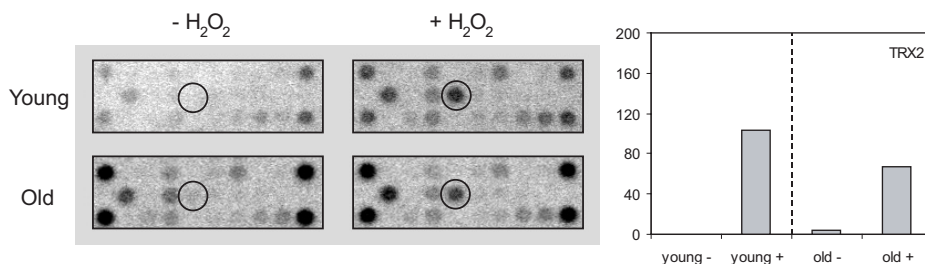
**Figure 5.3:** Viability of old and young yeast cells after exposure to hydrogen peroxide. Young cells (○) and old cells (◆) show the same sensitivity to 30-minute exposures with different concentrations of hydrogen peroxide.

## Transcriptional response of old cells to hydrogen peroxide compared to young cells

mRNA was isolated from old and young cells that were exposed for 30 minutes to 0.1 mM hydrogen peroxide. The isolated transcripts were used to perform microarray experiments as described in the Materials and Methods section. The expression of one of the most important antioxidant genes *TRX2* is less in the old cells after exposure to hydrogen peroxide than in the young cells (see figure 5.4). This pattern is also observed in several other components of the thioredoxin system (figure 5.5). The thiolperoxidases *TSA1* and *AHP1* show, just as *TRX2*, less induction in the old cells. This pattern repeats itself with the thioredoxin reductases *TRR1* and *TRR2*. *TRX1* demonstrates a decrease in expression after exposure to hydrogen peroxide in old cells. Only the thiolperoxidase *PRX1* shows an increase in old cells after exposure to hydrogen peroxide. *TRX3*, *TSA2* and *DOT5* are not induced at all, which fits earlier results described in chapter 3.

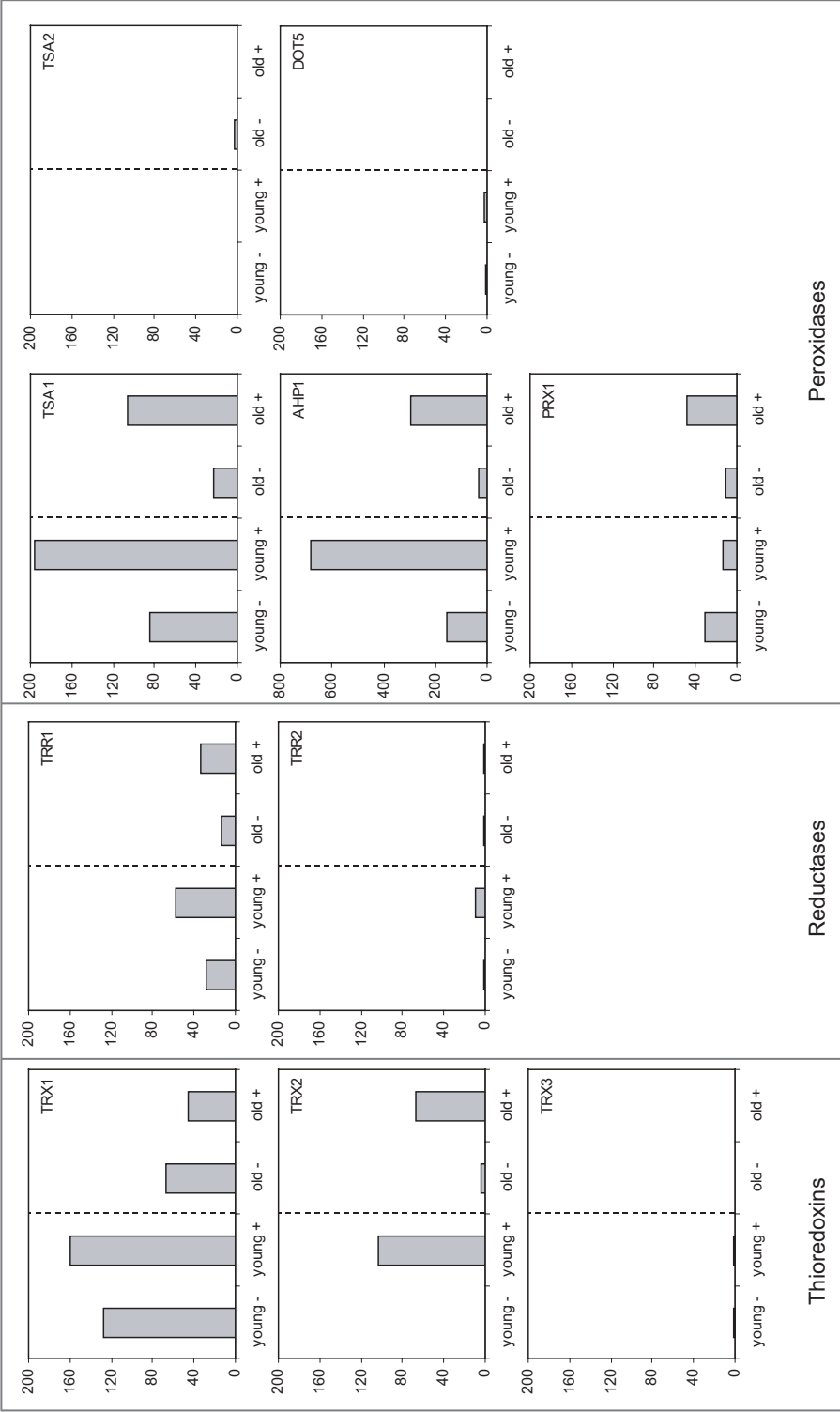
The basal levels without exposure to hydrogen peroxide also show differences between young and old cells. All the genes comprising the thioredoxin system show either lower expression in old cells than in young or are both in the young and old cells too low to be taken into account.

The glutathione system responds as depicted in figure 5.6. *GPX2* shows a similar response as *TRX2*; the transcription is less induced in the old cells. Both the synthetases *GSH1* and *GSH2* are also less induced in the old cells. However, the other genes from the glutathione system do not show this behaviour. *GRX4*, *GPX1* and *TTR1* demonstrate very low expression and *GLR1*, *GRX1*, *GRX3*, *GRX5* and *HYR1* display either no large differences between old and young cells, or only low expression in the old cells without hydrogen peroxide.



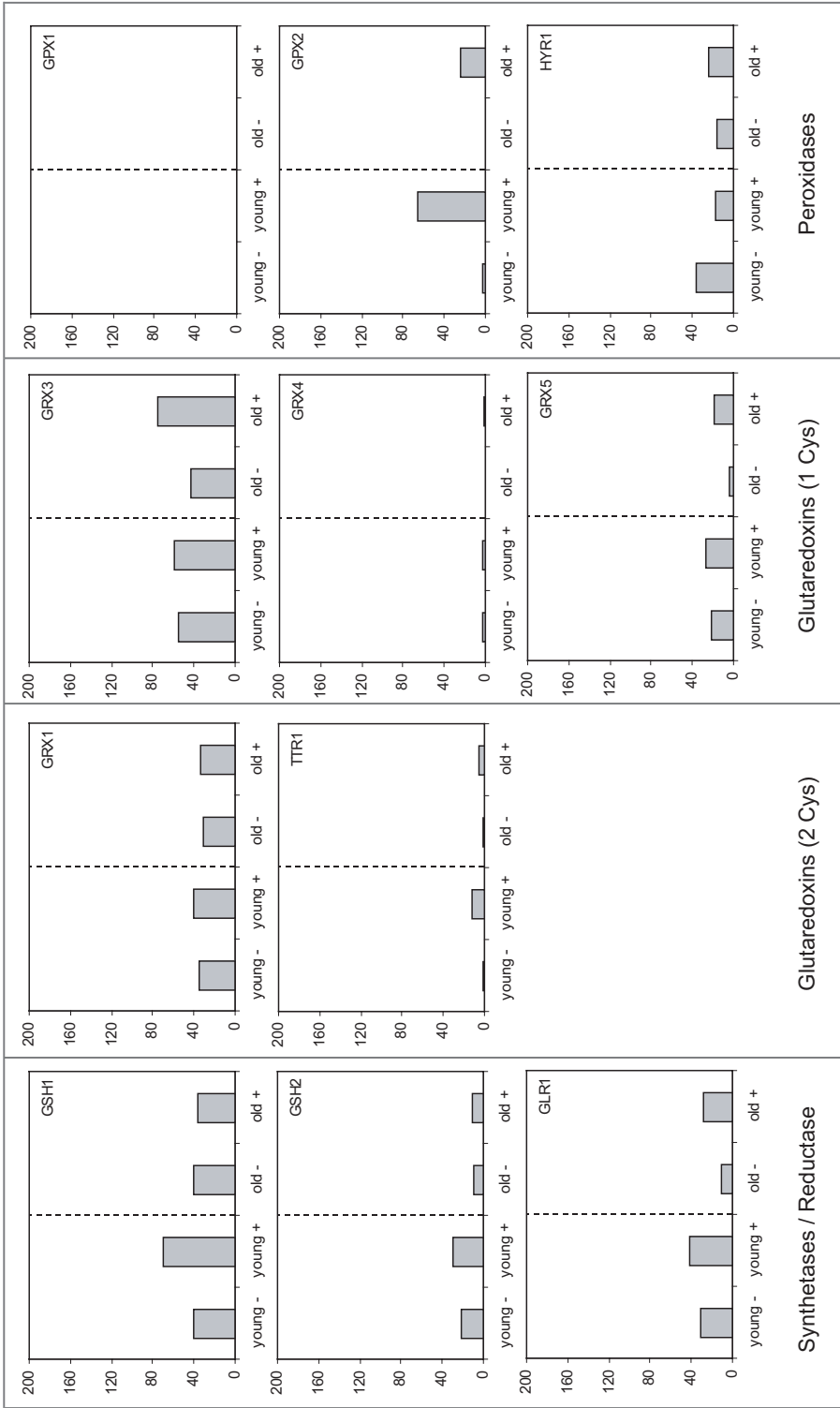
**Figure 5.4:** *TRX2* expression in young and old cells. Raw array data (left) and its quantification (right) showing expression of *TRX2* after exposing both old and young cells to 0.1 mM hydrogen peroxide.

**Figure 5.5:** Expression levels of the thioredoxin system in young cells vs. old cells after exposure to 0.1 mM hydrogen peroxide

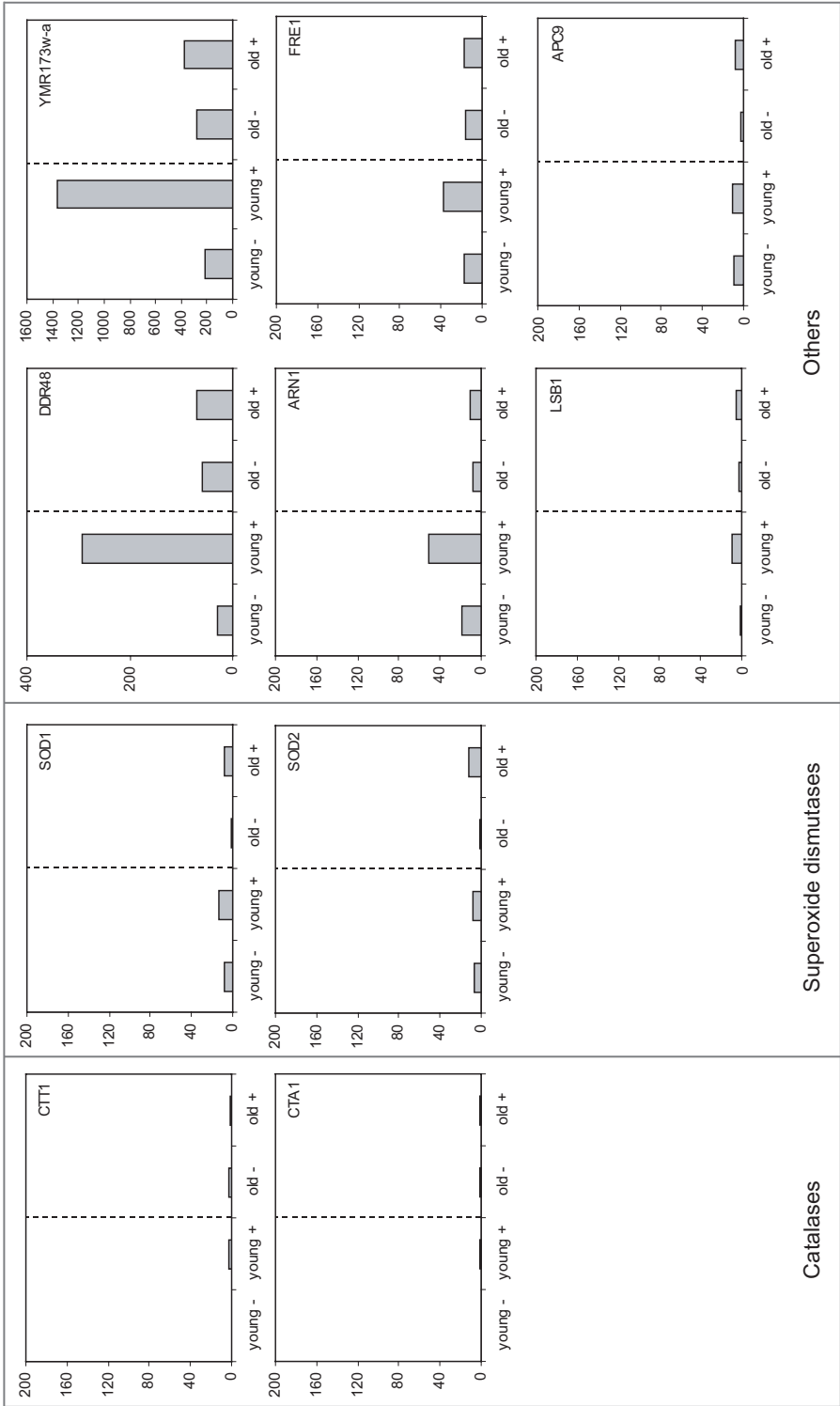




**Figure 5.6:** Expression levels of the glutathione system in young cells vs. old cells after exposure to 0.1 mM hydrogen peroxide



**Figure 5.7:** Expression levels of other stress responsive genes in young cells vs. old cells after exposure to 0.1 mM hydrogen peroxide



The basal expression levels of the genes comprising the glutathione system without exposure to hydrogen peroxide are not always influenced by the age of the cells. *GSH1*, *GRX1* and *GRX3* are expressed at the same levels in young and old while *GSH2*, *GLR1*, *GRX5* and *HYR1* are less expressed in the old cells. The other components do not have expression levels significant enough to draw conclusions from with respect to differences between old and young.

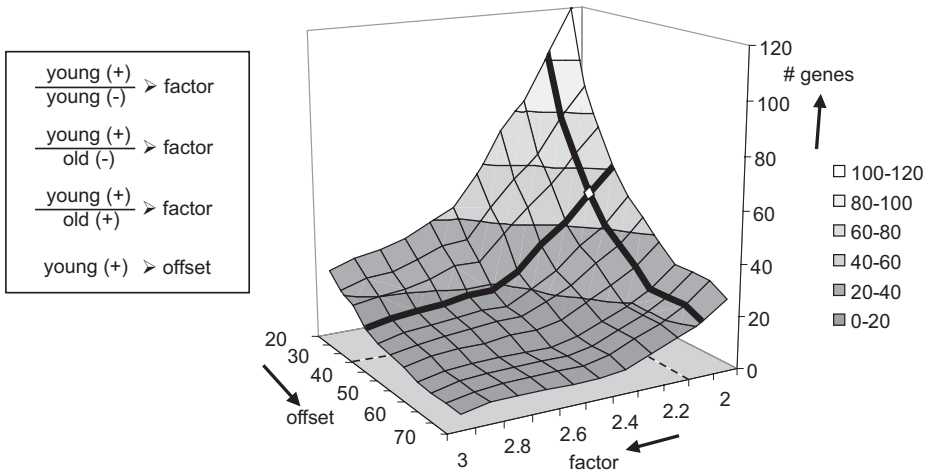
These observations are summarized in table 5.1. It is clear that the aging process influences the response of the thioredoxin system to hydrogen peroxide and that the influence of aging on transcription of the glutathione system is only minor. More genes are, next to the glutathione and the thioredoxin system, involved in counteracting oxidative stress. As shown in figure 5.7 the catalases and the superoxide dismutases both show a low expression, with or without exposure to hydrogen peroxide.

**Table 5.1:** The components of the major antioxidant systems; thioredoxin and glutathione, and their response to stress in young and old yeast cells.

Name	Description	Class	Young	Old
TRX1	Thioredoxin I	Thioredoxin	Incr.	Decrease
TRX2	Thioredoxin II	Thioredoxin	Incr.	Less increase
TRX3	Mitochondrial thioredoxin	Thioredoxin	-	-
TRR1	Thioredoxin reductase	Reductase	Incr.	Less increase
TRR2	Mitochondrial thioredoxin reductase	Reductase	Incr.	Less increase
TSA1	Cytosolic thioredoxin peroxidase	Peroxidase	Incr.	Less increase
TSA2	Cytosolic thioredoxin peroxidase	Peroxidase	-	-
AHP1	Alkyl hydroperoxide reductase	Peroxidase	Incr.	Less increase
DOT5	Nuclear thioredoxin peroxidase	Peroxidase	-	-
PRX1	Mitochondrial thioredoxin peroxidase	Peroxidase	Decr.	Increase
GSH1	$\gamma$ -Glutamylcysteine synthetase	Synthetase	Incr.	Decrease
GSH2	Glutathione synthetase	Synthetase	Incr.	Decrease
GLR1	Glutathione reductase	Reductase	Incr.	Increase
GRX1	Glutaredoxin containing 2 cysteines	Glutaredoxin	Equal	Equal
TTR1	Glutaredoxin containing 2 cysteines	Glutaredoxin	Incr.	Less increase
GRX3	Glutaredoxin containing 1 cysteine	Glutaredoxin	Equal	Increase
GRX4	Glutaredoxin containing 1 cysteine	Glutaredoxin	-	-
GRX5	Glutaredoxin containing 1 cysteine	Glutaredoxin	Incr.	Increase
GPX1	Glutathione peroxidase	Peroxidase	-	-
GPX2	Glutathione peroxidase	Peroxidase	Incr.	Less increase
HYR1	Glutathione peroxidase	Peroxidase	Decr.	Increase

In chapter 3, several genes revealed a remarkable response to hydrogen peroxide during the cell cycle. It was suggested that *DDR48*, *ARN1* and *FRE1* could be involved in protection of DNA. The response of these genes to hydrogen peroxide in young and old cells is depicted in figure 5.7. It appears that they are induced in the young cells after exposure to hydrogen peroxide. However, in the old cells the response is low.

This particular behaviour is the same as observed earlier with several genes from the thioredoxin system. To get a better idea about what exactly is happening in these old cells a search was conducted to find other genes that show this kind of expression pattern. The response of *DDR48* was captured in 4 equations (figure 5.8) that state that the ratio of the expression of the young cells with hydrogen peroxide divided by the expression of the young cells without hydrogen peroxide has to be larger than a certain factor. Young (+stress) divided by old (+stress) and young (+) divided by old (-) have to be larger than this factor too. The final equation states that the intensity of young (+) has to be above a threshold value; the offset. By varying offset and factor of induction, different sets of ‘similar’ responding genes were obtained. Applying these equations with our database revealed genes, which show just as *DDR48* an increase in expression in the young cells and no induction in the old cells.



**Figure 5.8:** Lowering both offset and factor results in increasing amounts of genes with similar expression patterns to *DDR48*. The bold lines indicate the chosen parameters (factor: 2.1, offset: 35). On the left are the equations given that search the database for genes with similar expression patterns.

The lower the offset and the factor of induction, the more genes were selected (figure 5.8). The values chosen for the factor and the offset were 2.1 and 35 because using these parameters *FRE1*, *ARN1* and *DDR48*, which are the genes that initiated this query, were all included in the dataset. This procedure revealed a list with 51 genes of which 11 genes were of unknown function and 1 gene was flagged. The remaining genes are listed in Table 5.2. All these genes display a reduced induction in old cells after exposure to hydrogen peroxide. There are 10 stress genes listed, 2 genes involved in protein degradation, 2 *LAP* genes involved in posttranslational modification, several genes involved transport of proteins or other compounds like metal ions, 4 genes involved in carbon metabolism, 3 genes which are essential steps in amino acid synthesis, 3 genes which play a part in telomere maintenance and silencing and another 8 genes of diverse categories.

### **Stress genes**

Ahp1 is one of the thiolperoxidases involved using thioredoxin as a reducing equivalent (Jeong *et al.*, 1999). Arn1 is a transporter of iron binding molecules or siderophores (Yun *et al.*, 2000b). Fre1 takes care of iron and copper transport and is able to reduce Fe(III) and Cu(II) ions (Hassett and Kosman, 1995). Metal ions like iron and copper are able to generate together with hydrogen peroxide the very reactive hydroxyl radicals via the Fenton reaction (Rice-Evans and Burdon, 1994).

Ddr48 is a protein of which the function is largely unknown although it is observed that the gene is specifically upregulated during stress conditions and in mutants that have defects in DNA metabolism (Treger and McEntee, 1990).

Dcs1 is a putative trehalase inhibitor (Souza *et al.*, 2002) preventing the important stress-protectant trehalose from degradation. Gre2 is a protein with oxidoreductase activity usually not associated with resistance to hydrogen peroxide but to diamide (Godon *et al.*, 1998). Pir1 is homologous with Hsp150, which displays more or less the same expression pattern although with lower levels. Hsp150 is involved in protection against oxidative stress (Ezaki *et al.*, 1998). Ste24 is a membrane spanning zinc dependent protease (Tam *et al.*, 2001). YKL161C is a serine/threonine kinase with similarities to Map kinase (Zhu *et al.*, 2000). *YMR173w-a* is an overlapping ORF with *DDR48* (Cherry *et al.*, 1997).

**Table 5.2:** Genes upregulated in a similar way as *DDR48***STRESS-genes**

---

<i>AHP1</i>	Alkyl hydroperoxide reductase
<i>ARN1</i>	Transport of ferrichromes
<i>DCS1</i>	Potential trehalase inhibitor
<i>DDR48</i>	Induced by heat shock, DNA damage, or osmotic stress
<i>FRE1</i>	Oxidoreductase activity, metal ion homeostasis
<i>GRE2</i>	Oxidoreductase activity
<i>PIR1</i>	Heat shock protein
<i>STE24</i>	Prelyl dependent protease
<i>YKL161C</i>	Serine/threonine protein kinase
<i>YMR173W-a</i>	Overlapping <i>DDR48</i>

**PROTEIN PROCESSING**

---

<i>LAP3</i>	Aminopeptidase
<i>LAP4</i>	Aminopeptidase of the vacuole

**PROTEIN DEGRADATION**

---

<i>RPN3</i>	Component of 26S proteasome complex
<i>UBP6</i>	Putative ubiquitin-specific protease

**TRANSPORT**

---

<i>ERD1</i>	Required for retention of luminal ER proteins
<i>FET3</i>	Cell surface ferroxidase
<i>GTR2</i>	Putative small GTPase, has similarity to Gtr1p
<i>NPR1</i>	Serine/threonine protein kinase regulating protein
<i>OAC1</i>	Oxaloacetate and sulfate transporter
<i>YGR138C</i>	Multi drug resistance transporter
<i>ZRT3</i>	Zn homeostasis

**METABOLISM**

---

<i>FBA1</i>	Fructose-bisphosphate aldolase II
<i>PGK1</i>	Phosphoglycerate kinase
<i>PFK27</i>	6-Phosphofructose-2-kinase
<i>TDH2</i>	Glyceraldehyde-3-phosphate dehydrogenase 2
<i>ARG7</i>	Ornithine acetyltransferase, Arg biosynthesis
<i>HIS5</i>	Histidinol-phosphate aminotransferase, Hys biosynthesis
<i>LEU2</i>	3-Isopropylmalate dehydrogenase, Leu biosynthesis
<i>SDT1</i>	Nucleotidase
<i>EPT1</i>	1,2-Diacylglycerol ethanolaminephosphotransferase

**TELOMERES**

---

<i>COS7</i>	Member of COS family, subtelomerically-encoded
<i>HST1</i>	Histone deacetylase
<i>YML133C</i>	Putative DNA helicase

**OTHERS**

---

<i>BBC1</i>	Myosin binding and actin regulation
<i>CAF17</i>	Component of the CCR4 transcription complex
<i>CTS1</i>	Endochitinase
<i>DSE1</i>	Chitin metabolism
<i>MRPL3</i>	Mitochondrial ribosomal protein of the large subunit
<i>VMA5</i>	Vacuolar H(+)-ATPase hydrophilic subunit

**UNKNOWN**

---

*YPL014W, YMR010W, YLR339C, YLR257W, YKL202W, YJL058C, YJL046W, YHR029C, YDL211C,*

## Protein processing

Lap4 interacts with Ssa1 and Ssa2, which are both members of the 70-kDa stress protein family and chaperones (Silles *et al.*, 2000). Moreover, both *SSA1* and *SSA2* display a decreased induction in old cells as well, although they did not turn up in the initial query because the factor of induction in the young cells is too low. *LAP4* as well as *SSA1* and *SSA2* are under transcriptional control of Yap1.

## Protein degradation

Rpn3 is a component of the 26S proteasome that displayed a *DDR48* like pattern. However, none of the other components of the 26S-proteasome behaves in the same fashion. On the other hand, there seems to be an association between Ubp6, which also shows a *DDR48* like expression pattern, and the proteasomal base especially its subunit Rpn1 (Leggett *et al.*, 2002). Ubp6 is a member of a family of deubiquitination proteins consisting of 17 members of which only *UBP11* shows a more or less similar pattern as *UBP6*. These data indicate that it is not likely that protein degradation is significantly altered in old and young cells exposed to hydrogen peroxide.

## Transport

In the category ‘transport’ (table 5.2) two genes are listed that are involved in metal ion uptake/transport. Although the uptake of iron by Fet3 is independent of Frel (Yun *et al.*, 2000b), which also behaves like *DDR48*, it is not independent of Arn3 (Yun *et al.*, 2000a), which is a close homologue of Arn1 but shows different response. The Zrt3 protein involved in maintaining Zinc homeostasis interacts amongst others with Bzz1 (Ito *et al.*, 2001), which also shows a *DDR48* like expression pattern although at low expression levels.

Erd1 is required for retention of luminal ER proteins (Hardwick *et al.*, 1990), Gtr2 is a putative GTPase possibly involved in protein nucleus import (Nakashima *et al.*, 1999). Npr1 is a kinase part of the RAS/PKA pathway between cAMP and PKA (Johnston *et al.*, 2001). Oac1 is a mitochondrial transporter involved in transport of amongst others thiosulfates (Palmieri *et al.*, 1999). Other transporters of the same family do not respond in the same way. Ygr138c is a polyamine transporter of which there are four in the yeast genome (Tomitori *et al.*, 2001). Of these four transporters, *YGR138c* has the highest expression levels but the *DDR48* like pattern is also observed with two other polyamine transporters.

## Metabolism

Fba1 has Zinc binding activity, induced by cAMP and is involved in glycolysis, actually several of the genes in the metabolism cluster play a role in glycolysis. Apparently the glycolysis is less induced by stress in old cells than in young cells.

Tdh1 is the minor dehydrogenase, only responsible for 10% of dehydrogenase activity while Tdh2 and Tdh3 take care of 87 % of dehydrogenase activity (McAlister and Holland, 1985). *PGH1* and *CDC19* show no induction by stress, *PFK2* displays no expression just as *GPM2*, *ERR1*, *ERR2* and *YMR323w*. *ENO2* is the only aberrant gene showing a slight increase in old cells and a slight decrease in young.

Sdt1 is a nucleotidase with specificity for pyrimidines (Nakanishi and Sekimizu, 2002) and Ept1 is involved in the biosynthesis of phosphatidylethanolamine (PE) (Menon and Stevens, 1992).

## Telomeres

The presence of *COS7* in table 5.2 triggered the examination of the other 10 *COS* genes which revealed that all *COS* genes show a decreased induction by stress in the old cells compared to the young ones. *COS7* is not the only gene encoded near the telomeres. Also the putative helicase from table 5.2, *YML133c* is encoded near the telomeres. Moreover, there are at least 24 very homologous open reading frames in the yeast genome and they are all located near the end of the chromosomes (Cherry *et al.*, 1997). Of these genes 14 display a reduced induction by stress in the old cells compared to the young.

Hst1 (Homolog of Sir Two; Sir2) is a NAD dependent histone deacetylase involved in transcriptional silencing. Hst1 forms together with Sum1 and Yor279c a repression complex involved in deacetylation of histones leading to repression of sporulation genes. Both Sum1 and Yor279c show less induction by hydrogen peroxide in old cells although less clear than Hst1. *HST1* is not the only gene involved in silencing displaying a *DDR48*-like expression pattern. From the stress-genes category, also the oxidoreductase Gre2 plays a role in silencing.



## **Others**

The last group of genes code for proteins performing diverse tasks. Bbc1 is involved in actin regulation, Caf17 is part of a Ccr4 transcription complex, Cts1 is a endochitinase, Dse1 is involved in chitin metabolism, Mrp13 is a mitochondrial ribosomal protein and Vma5 is part of a vacuolar ATPase.

## Discussion:

Isolating old yeast cells by centrifugal elutriation and subsequently exposing them to different concentration of hydrogen peroxide showed that there were no differences in viability when the cells were exposed to 0.1 mM of hydrogen peroxide. Young cells were more susceptible to stress when 1 mM of hydrogen peroxide was used. Because previous research claimed that several antioxidant proteins were lower in old cells, it was not expected that the young cells would be more vulnerable. Nevertheless, it can be that other proteins are more upregulated and by this way taking care of the necessary protection. Another possibility is that there are differences in cell wall composition between young and old cells leading to differences in exposure of cellular constituents to hydrogen peroxide.

To verify if antioxidant genes and antioxidant gene responses were lower in old yeast cells, mRNA of these cells was isolated with and without exposure to hydrogen peroxide. This mRNA was translated to radioactively labelled cDNA that was used for microarray experiments. This microarray data revealed that several genes of the thioredoxin system had higher levels of expression in the young cells, which was in line with earlier results. After exposing the cells to hydrogen peroxide, expression of most of the thioredoxin genes was induced. However, it was also observed that induction of these genes was less in the young cells than in the old cells. This could point to a reduced efficacy in dealing with oxidative stress, perhaps by dysregulation of stress response.

This conclusion does not agree with the observation that the young cells are more vulnerable than the old ones. However, the microarray data was generated using 0.1 mM of hydrogen peroxide while the difference in viability was only observed when 1 mM of hydrogen peroxide was used.

The components of the other major antioxidant system, the glutathione system, show a less clear age related response pattern. Although there are some genes expressed at lower levels in old cells, only one of the peroxidases and the first step in glutathione synthesis are less induced by hydrogen peroxide in old cells. Also the two catalases and superoxide dismutases show neither a high response, nor a specific age related response pattern (not shown). The tripeptide glutathione can scavenge hydrogen peroxide, and

regain electrons from NADPH. Thus, it could be that there is no need for most of the genes of the glutathione system to become higher expressed.

Previous experiments described in chapter 3 revealed a number of genes showing a specific stress response during the cell cycle. Several of these genes again show behaviour like described above for the thioredoxin system genes. *DDR48*, *ARN1*, *FRE1* and *YMR173W-A* show a clear induction by hydrogen peroxide in the young cells and no or little induction by hydrogen peroxide in the old cells. This could mean that cell cycle regulation is disturbed in old cells, but it can also mean that antioxidant defences are less responsive.

The dataset was specifically searched for other genes that responded to hydrogen peroxide in the young cells but did not respond to hydrogen peroxide in the old cells. This revealed a list with 39 known genes (table 5.2) of which several are involved in stress response, metabolism and genetic stability. These are categories also mentioned highlighted in chapter 1 to be of importance in the aging process. The fact that they are not or less responding to oxidative stress points to a decrease in gene regulation. Apparently, old cells respond less to exogenous challenges like hydrogen peroxide.

Glycolysis is induced by stress in young cells and not in old cells. This is partially in line with earlier published results revealing a shift from glycolysis to gluconeogenesis in old cells (Lin *et al.*, 2001). In this paper it was shown that cells of generation 7-8, express some genes involved in gluconeogenesis at a higher level than the young control cells. Interesting in our experiments is the induction by hydrogen peroxide of the glycolysis. Although very small amounts of oxygen radicals (10 nM – 1  $\mu$ M) are able to induce proliferation in mammalian cells (Rice-Evans and Burdon, 1994) this has not been reported in yeast so far. The idea that oxygen radicals can function as second messengers is a widely documented concept (Nathan, 2003) and it could explain why the glycolysis is induced by stress in our system. Although 0.1 mM is a 100-fold higher concentration than 1  $\mu$ M there is also a large difference in vulnerability between yeast and mammalian cells.

There could be another reason why glycolysis is upregulated by stress. One of the compounds generated during glycolysis is NADH. Although both the thioredoxin and glutathione system generally use NADPH as a reducing equivalent it is possible for NADH to recycle NADP<sup>+</sup> in mammalian cells. However this reaction is not possible in *S. cerevisiae* because it lacks a transhydrogenase capable of performing this task. The

glutathione reductase, Glr1, shows some affinity for NADH although more for NADPH so in this way NADH could still play a role in stress protection in this system (Tsai and Godin, 1987).

Another consideration concerning the involvement of glycolysis in stress is the fact that pyruvate can protect against the damaging effects of hydrogen peroxide. The consumption of pyruvate could drive the glycolysis pathway into producing more of this compound.

A remarkable observation is that the hydrogen peroxide seems to induce several genes at the end of the telomeres. These genes usually are silenced, however, stress induced silencing seems to be increased in old cells. Although another possibility is that not the silencing is increased but the gene regulation, in this case the stress response, is decreased. An increase in silencing is in contrast with earlier published results claiming that silencing is reduced in old cells leading for instance to simultaneous expression of both mating types consecutively leading to sterile cells (Smeal *et al.*, 1996).

NAD<sup>+</sup> is an important cofactor for Sir2 involved in silencing and aging (Landry *et al.*, 2000). Upregulation of glycolysis leads to a decrease in NAD<sup>+</sup> because it is turned into NADH. The decrease in NAD<sup>+</sup> could be responsible for a decrease in activity of NAD<sup>+</sup>-dependent deacetylases as Sir2, leading to a decrease in silencing, which in turn is the cause of increased *COS* and helicase expression.

What is clear from these results is that the expression of an important antioxidant system as thioredoxin is decreased in old cells and additionally is less responsive to external challenges like hydrogen peroxide. What does this tell us about the ‘physiological’ aging process of yeast? It could mean that the ROS produced during normal metabolism have more serious consequences for old cells because their antioxidant systems are lower and less responsive. Accumulating damage to lipids and proteins could cause increasing difficulties in maintaining redox potential. This in turn would explain a less responsive antioxidant system.

6

S

*creening for new antioxidants*

**Abstract:**

To be able to screen potential antioxidants for their ability to scavenge radical oxygen species (ROS) in living yeast cells, a multiwell assay was developed. This assay was based on the effect of antioxidants on the expression of a *TRX2* promoter controlled *LACZ* reporter gene. Vitamin E, which is an effective antioxidant, was capable of reducing the oxidative environment within the cell measured by the reduction in expression of LacZ. This was done both with and without exogenous added hydrogen peroxide. The observed effects were larger in a  $\Delta trx2$  deletion strain. Epicatechin gallate and chlorogenic acid were not able to reduce the expression of the reporter construct, only glutathione,  $\alpha$ - and  $\gamma$ -tocopherol showed the ability to decrease expression of the reporter construct, indicating the suitability of the screening system.

## Introduction:

Protection against reactive oxygen species (ROS) is a major issue in biological systems. Several scavenging and detoxification systems have evolved to deal with these harmful substances. However, these antioxidant systems are not always completely successful in eliminating ROS and several ROS are able to escape and damage cellular constituents. It has been shown before in trials that people using food supplements containing additional antioxidants like vitamin E can reinforce their defences against oxidative stress. For instance the beneficial effect of a stereo-isomer of vitamin E on the decrease in prevalence of myocardial infarctions in high-risk patients (Stephens *et al.*, 1996). However, these findings are controversial because it has also been found that vitamin E has no beneficial effects under the same circumstances of another trial (GISSI, 1999). This is not the only example of confusing data regarding potentially beneficial antioxidants.  $\beta$ -carotene is an infamous example of a compound that can display both antioxidant and prooxidant behaviour depending on the circumstances (Zhang and Omaye, 2001). In a trial published in 1996 it was observed that high doses of  $\beta$ -carotene led to a higher incidence of lung cancer in smokers (Omenn *et al.*, 1996).

Both these examples underline the need for reliable data concerning the behaviour of different antioxidants and their combinations in *in vivo* screening systems. In our case, *Saccharomyces cerevisiae* was chosen as a model system to develop a screeningsystem for antioxidants. Reasons for choosing this system are i) deletion strains with impaired antioxidant systems are readily available, ii) molecular techniques are well developed and iii) yeast is easy to cultivate. The advantage of using a mutant impaired in its antioxidant defence system is that the radicals are generated endogenously in contrast to exogenously added hydrogen peroxide. This is a better model for the 'natural' situation.

The finding described in chapter 4 that several antioxidant genes are less induced in old yeast cells after exposure to oxidative stress, suggests that old cells are partly impaired in their ROS-scavenging systems. This raises the question whether supplementing antioxidants can reinforce these defences. Potent antioxidant compounds are needed to perform these kinds of experiments, thus to find these, the following setup was designed.

In an exponentially growing culture of *Saccharomyces cerevisiae* cells respond rapidly to exposure to hydrogen peroxide by expressing antioxidant genes like *TRX2* and *GSH1* (Gasch *et al.*, 2000). Trx2 is a small protein involved in reducing disulfide bonds (Muller, 1991) and is required for resistance against hydrogen peroxide (Kuge and Jones, 1994). Gsh1 is the protein responsible for the first step in the biosynthesis of the tripeptide glutathione, which plays a role in scavenging oxygen radicals (Moradas-Ferreira *et al.*, 1996). The induction by hydrogen peroxide of *TRX2* and *GSH1* was used to construct an oxidant sensitive reporter system. The promoter regions of *TRX2* and *GSH1* were fused to a *LACZ* reporter gene after which wild type cells were transformed with these constructs. It was observed that expression of the reporter construct with the *GSH1* promoter was not induced very well by the exposure to oxidative stress, so further experiments were done with the *TRX2* strain. To obtain a strain with increased response to oxidative stress a  $\Delta trx2$  deletion mutant was transformed with the *TRX2* reporter construct. The cells were preincubated with potential antioxidants and incubated either with or without hydrogen peroxide. By measuring the decrease in activation of the reporter construct a measure of antioxidant efficacy was obtained. Five different antioxidants from different subgroups were tested;  $\alpha$ - and  $\gamma$ -tocopherol, which are two phenolic stereoisomers, epicatechin gallate, which is a catechine found for instance in green tea, chlorogenic acid, which is a flavonoid ubiquitous in plants, and glutathione, which is a cysteine-containing tripeptide endogenous to yeast. Only the tocopherols and the glutathione showed the ability to decrease expression of the reporter construct.



## Material & Methods:

### Strains and growth conditions:

In all experiments the wildtype strain CEN-PK113-7D (*MATa SUC2 MAL2-8c MEL*) also known as VWk43 was used. To construct the reporterplasmid, the *TRX2* promoter region was amplified from CEN-PK102-3A (*MATa SUC2 MAL2-8c MEL ura3 leu2*) or VWk18 chromosomal DNA with primers TRXL-MV (5'-GCGGGATCCTGACACCAAAGCTGTAC-3') and TRXR-MV (5'-GCGCCCGGGCATTATTGATGTGTTATTTAAAG-3'). This PCR fragment was cloned into pFA6a-lacZMX3 after a BamHI/XmaI digestion resulting in pUR5881. After BstEII partial linearization this plasmid was integrated into yeast chromosomal DNA of VWk43 resulting in VWk43-pTRX2- $\beta$ -gal (pUR5881) hereafter referred to as VWk43pTRX. The endogenous *TRX2* sequence was not disturbed as the construct integrates in front of the gene.

To construct the second reporterplasmid, the *GSH1* promoter region was amplified from CEN-PK102-3A (*MATa SUC2 MAL2-8c MEL ura3 leu2*) or VWk18 chromosomal DNA with primers GSHL-MV (5'-GCGGGATCCCATGCCTGTTGCTGCTGCTCTTG-3') and GSHR-MV (5'-GCGCCCGGGCATTATTCTTCTATATGTATA-3'). This PCR fragment was cloned into pFA6a-lacZMX3 after BamHI/XmaI digestion, resulting in pUR5880. After Ball linearization, this plasmid was integrated into yeast chromosomal DNA of VWk43 resulting in VWk43-pGSH1- $\beta$ -gal (pUR5880) hereafter referred to as VWk43pGSH. The endogenous *TRX2* sequence was not disturbed as the construct integrates in front of the gene. CEN-PK269-2A (*Δtrx2, leu2*), which is a strain devoid of thioredoxin2, was also transformed with pUR5881.

The construction of the wild-type strains with reporter plasmid was done by Anne Marie Verbiest at the Unilever Research Laboratory in Vlaardingen.

Cultures were grown at 30°C in a rotary shaker at 180 rpm in Yeast Nitrogen Based medium (YNB, Difco) with 1-2 % glucose or galactose as indicated.

### $\beta$ -galactosidase assay:

Yeast cells were grown at 30°C after which either they were or were not exposed to hydrogen peroxide.  $\beta$ -Galactosidase assays were essentially performed as

described in Maniatis (Sambrook *et al.*, 1989) with modifications. Triple samples of each 150  $\mu$ l were taken and added to a 96-multiwellplate with V-shaped wells. While taking the samples, this plate was kept at  $-20^{\circ}\text{C}$ . After sampling the plate was slowly thawed at  $0^{\circ}\text{C}$  after which the cells were spun down and the supernatant was discarded. To each well 20  $\mu$ l of 0.05 % Triton X-100 in 0.1 M Tris pH 7.5 and the samples were frozen to  $-80^{\circ}\text{C}$  to ensure lysis of the cells. After defrosting 80  $\mu$ l of Z-buffer (60 mM  $\text{Na}_2\text{HPO}_4$ , 40 mM  $\text{NaH}_2\text{PO}_4$ , 10 mM KCl, 1 mM  $\text{MgSO}_4$ , 0.25 mM DTT) and 20  $\mu$ l of 1 mg/ml o-nitro-phenyl- $\beta$ -galactopyranoside (Sigma-Aldrich Chemie B.V., Zwijndrecht, Netherlands) in 0.1 M  $\text{KH}_2\text{PO}_4/\text{K}_2\text{HPO}_4$  (pH 7) was added. The reaction was stopped by addition of 50  $\mu$ l of 1 M  $\text{Na}_2\text{CO}_3$ . The plate was then spun down, the supernatant was transferred to a flat bottom multiwellplate and the cell debris was resuspended in 150  $\mu$ l PBS and also transferred to a flat bottom multiwellplate. The supernatant was measured in a multiwellreader at 415 nm and the resuspended debris was measured at 655 nm. Usually the amount of LacZ was corrected for the amount of cells by dividing the absorption at 415 nm by the optical density at 655 nm or the data were given separately.

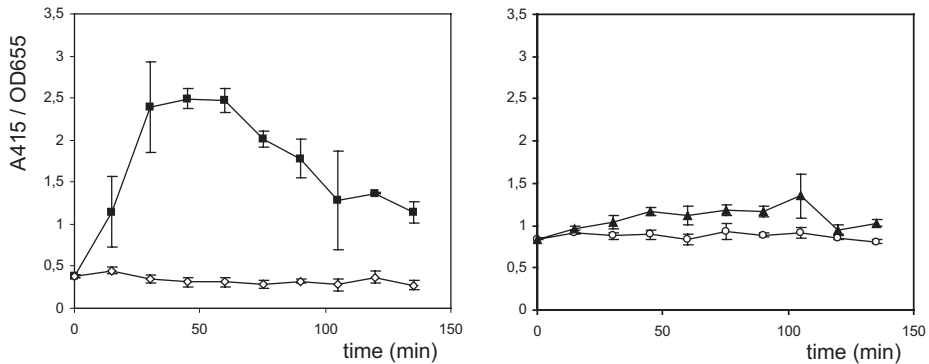
#### **Incubation with antioxidants:**

Cells were incubated in medium supplemented with different antioxidants for 5 hours, or otherwise mentioned. Ascorbic acid (vitamin C, Brunswig Chemie BV, Amsterdam, Netherlands) was dissolved in water to a concentration of 5 mM and subsequently diluted to appropriate concentrations. Both the  $\alpha$ -tocopherol (vitamin E, Merck Sharp & Dohme BV, Haarlem, Netherlands) and the  $\gamma$ -tocopherol (vitamin E, Sigma-Aldrich Chemie B.V., Zwijndrecht, Netherlands) were dissolved in ethanol to a concentration of 100 mM respectively 111 mM and then diluted in fetal calf serum (Gibco, Paisley, UK) to 0.25 mM and subsequently added to the cells in appropriate concentrations. Chlorogenic acid (Sigma-Aldrich Chemie B.V., Zwijndrecht, Netherlands), Epicatechinegallate (ECG, provided kindly by Unilever, Vlaardingen, Netherlands) and GSH (Sigma-Aldrich Chemie B.V., Zwijndrecht, Netherlands) were dissolved in water and subsequently diluted in medium. The cells were shaken with a rotational plate shaker (Heidolph Titramax 100, LaboTech BV, Ochten, Netherlands) and covered with a lid to prevent evaporation of the medium. The whole setup was kept at  $30^{\circ}\text{C}$ .

## Results:

### Trx2 reporter construct shows more induction by hydrogen peroxide than Gsh1 reporter construct

Trx2 and Gsh1 are the two main players of the thioredoxin and glutathione system, which are both induced by hydrogen peroxide (Gasch *et al.*, 2000). The promoter region of these two genes was ligated to a *LACZ* reporter gene. The response to hydrogen peroxide of both reporter constructs is depicted in figure 6.1. The reporter with the *TRX2* promoter shows a steep increase after the start of the incubation with hydrogen peroxide. After 30 minutes the expression of LacZ reaches a maximum at which it stays for another 30 minutes followed by a slowly decreasing signal. The expression of reporter system with the *GSH1* promoter also increases after exposure to hydrogen peroxide but only approximately 1.5-fold while the reporter with *TRX2* promoter displays approximately a 6-fold increase.

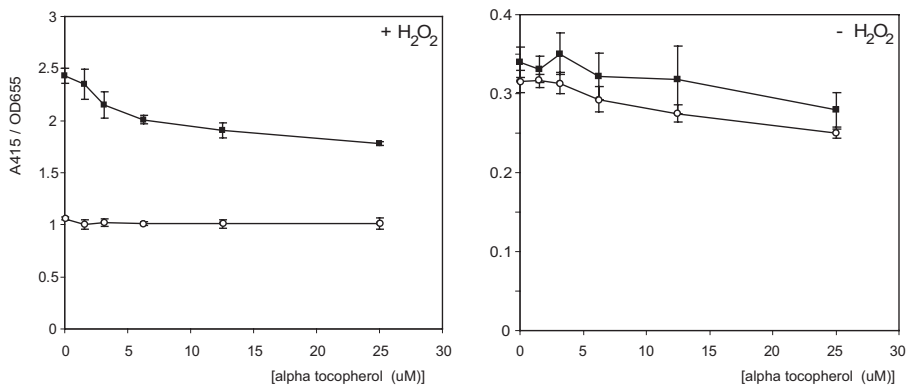


**Figure 6.1:** The response of *TRX2* and *GSH1* different reporter constructs. Both VWk43pTRX (left) and VWk43pGSH (right) were exposed to 0.5 mM hydrogen peroxide. ■: VWk43pTRX + hydrogen peroxide, ◇: control, ▲: VWk43pGSH + hydrogenperoxide, ○: control.

### Vitamin E is able to decrease expression of the reporter construct

As mentioned before, antioxidants could have a protective effect by their radical scavenging activities. However, preincubation of yeast cells with different concentrations of  $\alpha$ -tocopherol (vitamin E) does not reduce the hydrogen peroxide induced expression of the reporter construct as shown in figure 6.2 (left panel, ○). The

expression levels of *lacZ* are in this case not influenced by the  $\alpha$ -tocopherol. In this case  $\alpha$ -tocopherol is not able to decrease the oxygen stress. However, incubation of  $\Delta trx2pTRX$  strain (figure 6.2, left panel, ■) with different concentrations of  $\alpha$ -tocopherol (5-25  $\mu$ M) results in a decrease in hydrogen peroxide induced expression of approximately 1.5-fold when incubated with 25  $\mu$ M  $\alpha$ -tocopherol. Apparently the ‘sensed’ oxidative stress inside the cell decreases by preincubating with vitamin E. Both strains show, also without the exposure to hydrogen peroxide, a decrease in expression when they are incubated with  $\alpha$ -tocopherol (figure 6.2, right panel). This shows that  $\alpha$ -tocopherol is able to reduce the endogenous oxidative stress levels.

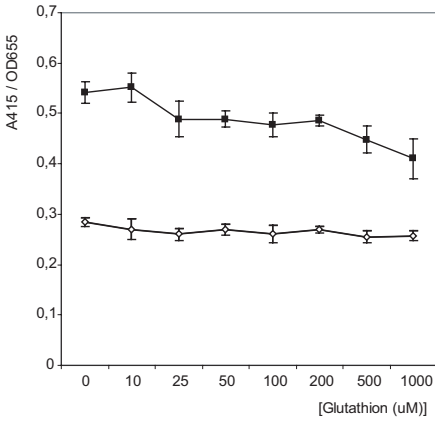


**Figure 6.2:** The effect of  $\alpha$ -tocopherol on expression of the reporterconstruct in wildtype cells, VWk43pTRX (○) and a strain deleted for *trx2*,  $\Delta trx2pTRX$  (■). The left panel shows that cells of the deletion strain have decreasing expression of the reporterconstruct with increasing  $\alpha$ -tocopherol concentrations when the cells are subsequently exposed to 0.5 mM hydrogen peroxide. The right panel shows that both in the wild-type cells and in the deletion strain preincubation with hydrogen peroxide leads to a decrease in expression without the addition of hydrogen peroxide.

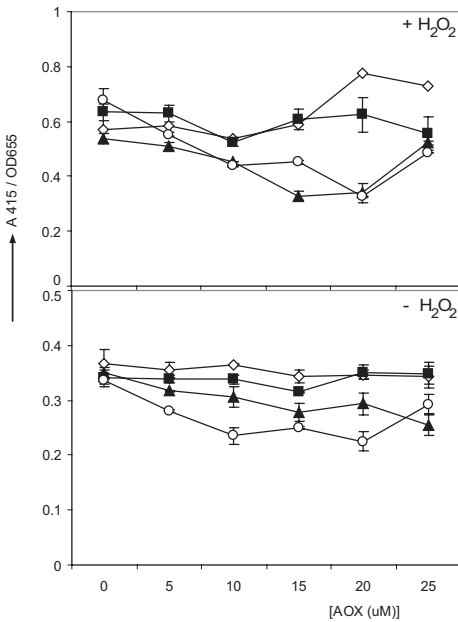
### Glutathione is able to lower expression of reporter construct in $\Delta trx2$ but not in wild type

Wild type cells were incubated with different concentrations (10-1000  $\mu$ M) of the tripeptide glutathione. No significant decrease in expression of the reporter construct is observed (figure 6.3). Apparently, administering additional glutathione has no protective effect. However, preincubation with different concentrations glutathione led to a decrease in expression of the reporter construct in the  $\Delta trx2pTRX$  strain.

Apparently is glutathione able to decrease the internal oxidative stress in the deletion strain, but not in the wild-type.



**Figure 6.3:** The effect of glutathione on the expression of the reporterconstruct in wild-type cells (◇) and in the *trx2* deletion strain (■).



**Figure 6.4:** The effect of different antioxidants on the expression of the reportersystem with and without exposure to hydrogen peroxide. ○: α-tocopherol, ◇: ECG, ▲: γ-tocopherol, ■: chlorogenic acid.

Because the deletion strain of *TRX2* seems to be more responsive to oxidative stress and to the preincubation with antioxidant genes, this strain was used to test other potential antioxidant compounds. Preincubation with epicatechegallate (ECG), chlorogenic acid, α-tocopherol and γ-tocopherol and their effect on the expression of the reporter construct is shown in figure 6.4 both with and without subsequent exposure to hydrogen peroxide. The effect of α-tocopherol on the decrease in expression of the reporter construct is again observed although there is an increase at 25 μM both in cells with and without exposure to hydrogen peroxide. γ-tocopherol is also able to reduce the expression of the reporter but shows an increase in expression at 25 μM like α-tocopherol. The preincubation with chlorogenic acid shows some fluctuations but no clear increase or decrease in expression of the reporter. The same holds for ECG, although preincubation with 20 and 25 μM leads to an increase in expression of the reporter if subsequently exposed to hydrogen peroxide. Both ECG and chlorogenic acid do not seem to be very potent antioxidants in this system.

## Discussion:

A method was developed to screen potential new antioxidants by measuring the effects of incubating yeast cells with these compounds on the expression of a reporter construct. Either the promoter region of *TRX2* or the promoter region of *GSH1* was fused to a *LACZ* reporter gene and subsequently integrated into the genome. It was observed that expression of LacZ protein increased after exposure to hydrogen peroxide in both strains. However, the *TRX2* construct had a much larger response. This is in line with earlier observations (chapters 3, 4 and 5) and thus the *TRX2* construct was selected for further experiments. To obtain a more sensitive reporter strain to use for the screening of the antioxidants, also a  $\Delta trx2$  deletion strain was transformed with this construct.

Incubation of cells with vitamin E prior to exposure to hydrogen peroxide led to a decrease in expression of LacZ compared to control cells that were not incubated with this antioxidant. This suggests that vitamin E, at least partly, is capable to neutralise the hydrogen peroxide. However, this was only observed in  $\Delta trx2$  deletion mutants and not in the wild type. The expression also decreased in the cells preincubated with vitamin E that were not exposed to hydrogen peroxide, both in the wild type and the deletion strain. Apparently the vitamin E is able to cope with endogenous radicals as well.

Glutathione was able to decrease expression in the  $\Delta trx2$  deletion strain in the absence of exogenously added hydrogen peroxide but not in the wildtype. Vitamin E preincubation led to a decrease in expression both in the wild type and the deletion strain. This suggests that the way in which glutathione and vitamin E reduce the oxidative stress is different, for instance because of different localizations. Vitamin E is hydrophobic and therefore preferably located in hydrophobic environments like membranes (Drummen *et al.*, 2002). Glutathione is much more hydrophilic and therefore located in different environments than vitamin E. This could explain why differences in decreasing stress response were present.

The absence of an effect on the decrease of the stress response when EGC and chlorogenic acid were used is not in line with earlier results (Drummen, 2000). However, both lipid vesicles and RAT fibroblasts were used in this study, which may cause these differences. There is no question that the bioavailability in both systems for different compounds can be considerably different.





7

G

*eneral discussion*

## General Discussion

*Saccharomyces cerevisiae* has been used as a model system to study aging processes since it was discovered that the yeast ages (Mortimer and Johnston, 1959). Usually the amount of produced daughter cells is used as the parameter denoting the age of a cell. The budscar left at the surface of a cell after producing a daughter makes it possible to determine the cells' age. Apart from the amount of budscars there are also several other phenotypic changes occurring during aging of yeast. Most of all, the age dependent increase in mortality, which is a hallmark of aging, indicates that this model system can be used to study aging. The fact that recently a process as caloric restriction was found to occur in *S.cerevisiae*, made it even more attractive (Jiang *et al.*, 2000; Lin *et al.*, 2000). One of the big advantages of using yeast as a model organism is that environmental conditions can be kept constant and reproducible. As seen in the previous chapters, growth rate is important in determining longevity. Using methods as continuous culturing and fed batch, these growth rates can be controlled very precisely. This gives *S.cerevisiae* a unique selling point compared to other model organisms for elucidating molecular mechanisms involved in aging.

Restricted access to carbon sources is not the only way in which growth rate can be reduced and subsequent longevity can be enhanced. Also limiting nitrogen sources, applying heat-shock or osmo-shock can decrease growth rate and at the same time increase replicative lifespan (Shama *et al.*, 1998; Jiang *et al.*, 2000; Swiecilo *et al.*, 2000; Kaeberlein *et al.*, 2002). In chapter 2 was described that besides the upregulation of *PNC1*, which ensures removal of Sir2 inhibitor nicotinamide, also a stress response was observed during carbon limitation induced slow growth conditions. This stress response consisted of an increase in stress-protectant trehalose synthesis, upregulation of oxidative stress response genes and upregulation of the proteasome. This suggests that an increased stress response during slow growth could be facilitating associated longevity.

Stress response, growth rate and longevity are connected to each other in several ways. The growth rate of *S.cerevisiae* is mainly determined by the length of the G1-phase (Silljé *et al.*, 1997). To observe whether the stress response is also influenced by the phase of the cell cycle, synchronous cells were exposed to oxidative stress at different timepoints during the cell cycle. This revealed that several transcripts of the

thioredoxin system show besides a stress dependent, a cell cycle dependent transcription pattern with the focus on the S-phase, probably to protect DNA from being damaged (see chapter 3). Subsequent experiments carried out with a promoter construct revealed that this S-phase dependency was also observed on protein level. However, it turned out that this was a general effect on protein synthesis (see chapter 4).

As mentioned in the introduction there are several genes known that, when mutated or overexpressed, increase lifespan (chapter 1). Although they need not to be involved in the 'normal' aging process per se, it is reasonable to believe that the common themes they symbolize are at the origin of aging. Two themes arise from the list: metabolism, notably the PKA pathway, and genetic stability. PKA is also involved in organizing an appropriate stress response via *Msn2/Msn4*, *Skn7* and possibly *Yap1* (Hasan *et al.*, 2002) (Charizanis *et al.*, 1999). Some previous data seems to indicate that oxidative stress response is diminished in aging yeast cells (Grzelak *et al.*, 2001; Laun *et al.*, 2001). To test this, several methods described in chapter 5 were tried to isolate old yeast cells to be able to expose them to oxidative stress. Eventually the method developed by Woldringh *et al.* (Woldringh *et al.*, 1995) yielded the best results; a large population enriched in older cells (+/- 7 generations). The exposure of these cells to hydrogen peroxide and the subsequent analysis of its transcriptional response by microarray experiments revealed that the levels and the response of several antioxidant genes were decreased in the old cells. Especially the genes of the thioredoxin antioxidant system were influenced. The responsiveness to oxidative challenges of the thioredoxin system exceeding that of the glutathione system seems to be a reoccurring phenomenon. Both chapter 3 and 5, where transcription is measured by microarray analysis, as well as chapter 6, where a *GSH1* and a *TRX2* reporterconstruct were used, showed minor induction of genes involved in the glutathione system.

In chapter 3 and 4 was shown that yeast has a cell cycle dependent response to oxidative stress both on a transcriptional and translational level. Apparently, the translation of proteins is generally reduced during the early G1, perhaps because of lack of ribosomes. This would probably not be the case in full grown mother cells that already went through several cell cycles, but in these cells also G1 duration is shorter. The next step would be to look at the transcriptional response of synchronous cells proceeding through the cell cycle of both young and old cells. It was shown in chapter 3 that several genes are specifically upregulated around S-phase after exposure to hydrogen peroxide, possibly for additional protection of the DNA. It would be

interesting to see whether the observed cell cycle dependent regulation of these antioxidant genes is also visible in old yeast cells. It is to be expected that because of diminished regulation of antioxidant genes in old cells as shown in chapter 5, less additional protection leading to damage potentially speeding up the aging process will probably occur.

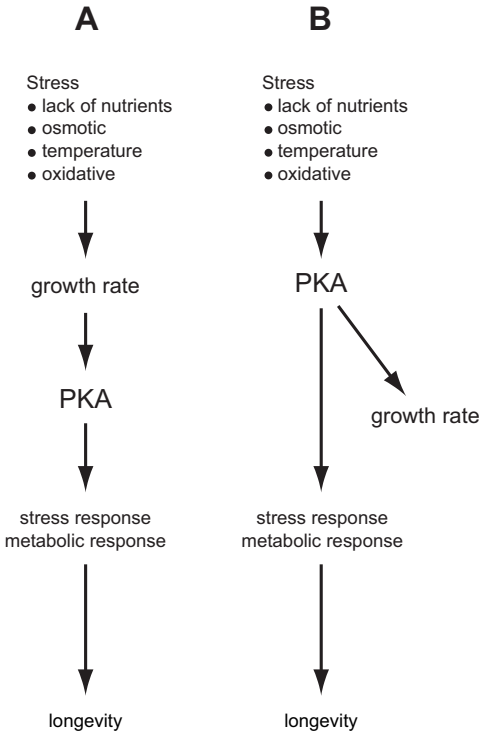
Apparently an oxidative stress response is involved during lifespan elongating slow growth conditions and in aged cells. This raises the question whether the screening method described in chapter 6 really reveals anti-aging compounds because they actually downregulate the endogenous stress response gene *TRX2*. The compounds that were screened using this method reveal antioxidant properties, but how this will affect the cell is still unclear. As shown in chapter 6, the addition of for instance vitamin E can downregulate the expression of a reporter construct with a thioredoxin promoter. As a consequence, the concentration of the thioredoxin protein is probably also lowered. Although the added vitamins can reinforce the diminished antioxidant capacity it is still questionable whether total antioxidant capacity is higher, equal or lower compared to the level before supplementing the cells with antioxidants. It is therefore necessary to find a suitable aging marker in yeast besides expression of antioxidant genes to elucidate whether supplementation of antioxidants is successful in combating aging.

Culture conditions used in the lab are different from the circumstances in which yeast grows in its natural habitat. Continuous supply with high-grade nutrients is not very common in nature. Long periods of less optimal growth conditions have to be survived to be able to take chances on the occasion that conditions improve. Less optimal growth conditions can have diverse causes, like lack of nutrients. However, situations where high temperature, osmotic stress and oxygen stress occur can significantly influence growth. All these adverse growth conditions have in common that they decrease the growth rate. Interestingly these treatments, if moderately applied, also are able to increase replicative lifespan. The way these environmental conditions are able to do so, is in my opinion a combined effort of both increasing the genetic stability and an elevated stress response or agility to anticipate on worsening conditions, see chapter 2. It seems as if the cell braces itself for impact, with two consequences; it can withstand stressful conditions and at the same time as by-product its longevity is extended. Is there no downside to this behaviour? Growing slowly will imply an evolutionary disadvantage compared to other species that grow faster, however because

this implies that these species will not survive the next period of food scarcity, it makes sense how this trait could have evolved. To take the synthesis of trehalose as an example, without trehalose the cell is not able to survive periods of starvation (Silljé *et al.*, 1999). Synthesis of trehalose takes energy away from the glycolysis, which gives a cell that doesn't synthesize trehalose an advantage because it will be able to spend more resources on growth and progeny. However it will not, nor will its progeny, be able to survive a period of scarcity.

The experiments done by Ashrafi *et al.* (Ashrafi *et al.*, 1999), indicate that there is an optimum in the effect of slow growth on longevity. Cells kept in stationary phase for extended periods of time show a decreased replicative lifespan afterwards. Although stationary phase and elongated G1 are probably not completely the same (Herman, 2002), it is remarkable that slightly elongating G1 can increase replicative lifespan while considerably lengthening G1 (stationary phase) leads to a decrease in subsequent replicative lifespan.

Remains the question whether growth rate is determining PKA activity and subsequent transcriptional response (figure 7.1A) or that the different environmental conditions determine PKA activity, which subsequently controls growth rate (figure 7.1B). This is of course a simplification of the situation because the PKA pathway is not the only one involved in nutrient and stress signalling. Also PKC and the TOR pathway are contributing to this signalling (Crespo and Hall, 2002; Longo, 2003). Scenario A implies a more general effect by different stressors on growth rate, while scenario B suggests that the several stressors each have their own separate route leading to deactivation of PKA which has as consequence that growth rate is affected.



**Figure 7.1:** Different ways in which growth rate could be involved in nutrient and stress signalling

The general conclusion, using yeasts unique feature concerning controllable culture conditions, is that exposing cells to adverse growth conditions will lead to a stress response that potentially facilitates longevity. In a nutshell: what doesn't kill you makes you stronger.



*R*eferences & Literature

## References & Literature

- Anderson, G.J., Lesuisse, E., Dancis, A., Roman, D.G., Labbe, P., and Klausner, R.D. (1992). Ferric iron reduction and iron assimilation in *Saccharomyces cerevisiae*. *J Inorg Biochem* 47, 249-255.
- Anderson, R.M., Bitterman, K.J., Wood, J.G., Medvedik, O., Cohen, H., Lin, S.S., Manchester, J.K., Gordon, J.I., and Sinclair, D.A. (2002). Manipulation of a nuclear NAD<sup>+</sup> salvage pathway delays aging without altering steady-state NAD<sup>+</sup> levels. *J Biol Chem* 277, 18881-18890.
- Anderson, R.M., Bitterman, K.J., Wood, J.G., Medvedik, O., and Sinclair, D.A. (2003). Nicotinamide and PNC1 govern lifespan extension by calorie restriction in *Saccharomyces cerevisiae*. *Nature* 423, 181-185.
- Arking, R. (1998). *Biology of Aging*. Sinauer Associates, Inc: Sunderland.
- Ashrafi, K., Lin, S.S., Manchester, J.K., and Gordon, J.I. (2000). Sip2p and its partner snf1p kinase affect aging in *S. cerevisiae*. *Genes Dev* 14, 1872-1885.
- Ashrafi, K., Sinclair, D., Gordon, J.I., and Guarente, L. (1999). Passage through stationary phase advances replicative aging in *Saccharomyces cerevisiae*. *Proc Natl Acad Sci U S A* 96, 9100-9105.
- Barja, G., and Herrero, A. (2000). Oxidative damage to mitochondrial DNA is inversely related to maximum life span in the heart and brain of mammals. *Faseb J* 14, 312-318.
- Begley, T.J., Rosenbach, A.S., Ideker, T., and Samson, L.D. (2002). Damage Recovery Pathways in *Saccharomyces cerevisiae* Revealed by Genomic Phenotyping and Interactome Mapping. *Mol Cancer Res* 1, 103-112.
- Benaroudj, N., Lee, D.H., and Goldberg, A.L. (2001). Trehalose accumulation during cellular stress protects cells and cellular proteins from damage by oxygen radicals. *J Biol Chem* 276, 24261-24267.
- Benton, B.K., Tinkelenberg, A.H., Jean, D., Plump, S.D., and Cross, F.R. (1993). Genetic analysis of Cln/Cdc28 regulation of cell morphogenesis in budding yeast. *Embo J* 12, 5267-5275.
- Bitterman, K.J., Medvedik, O., and Sinclair, D.A. (2003). Longevity Regulation in *Saccharomyces cerevisiae*: Linking Metabolism, Genome Stability, and Heterochromatin. *Microbiol Mol Biol Rev* 67, 376-399.
- Bouquin, N., Johnson, A.L., Morgan, B.A., and Johnston, L.H. (1999). Association of the cell cycle transcription factor Mbp1 with the Skn7 response regulator in budding yeast. *Mol Biol Cell* 10, 3389-3400.
- Carmel-Harel, O., Stearman, R., Gasch, A.P., Botstein, D., Brown, P.O., and Storz, G. (2001). Role of thioredoxin reductase in the Yap1p-dependent response to oxidative stress in *Saccharomyces cerevisiae*. *Mol Microbiol* 39, 595-605.
- Carmel-Harel, O., and Storz, G. (2000). Roles of the glutathione- and thioredoxin-dependent reduction systems in the *Escherichia coli* and *saccharomyces cerevisiae* responses to oxidative stress. *Annu Rev Microbiol* 54, 439-461.
- Carter, B.L., and Jagadish, M.N. (1978). Control of cell division in the yeast *Saccharomyces cerevisiae* cultured at different growth rates. *Exp Cell Res* 112, 373-383.
- Chang, K.T., and Min, K.T. (2002). Regulation of lifespan by histone deacetylase. *Ageing Res Rev* 1, 313-326.



- Charizanis, C., Juhnke, H., Krems, B., and Entian, K.D. (1999). The oxidative stress response mediated via Pos9/Skn7 is negatively regulated by the Ras/PKA pathway in *Saccharomyces cerevisiae*. *Mol Genet* 261, 740-752.
- Cherry, J.M., Ball, C., Weng, S., Juvik, G., Schmidt, R., Adler, C., Dunn, B., Dwight, S., Riles, L., Mortimer, R.K., and Botstein, D. (1997). Genetic and physical maps of *Saccharomyces cerevisiae*. *Nature* 387, 67-73.
- Clancy, D.J., Gems, D., Harshman, L.G., Oldham, S., Stocker, H., Hafen, E., Leevers, S.J., and Partridge, L. (2001). Extension of life-span by loss of CHICO, a *Drosophila* insulin receptor substrate protein. *Science* 292, 104-106.
- Collinson, E.J., Wheeler, G.L., Garrido, E.O., Avery, A.M., Avery, S.V., and Grant, C.M. (2002). The yeast glutaredoxins are active as glutathione peroxidases. *J Biol Chem* 277, 16712-16717.
- Crespo, J.L., and Hall, M.N. (2002). Elucidating TOR signaling and rapamycin action: lessons from *Saccharomyces cerevisiae*. *Microbiol Mol Biol Rev* 66, 579-591, table of contents.
- Defossez, P.A., Prusty, R., Kaeberlein, M., Lin, S.J., Ferrigno, P., Silver, P.A., Keil, R.L., and Guarente, L. (1999). Elimination of replication block protein Fob1 extends the life span of yeast mother cells. *Mol Cell* 3, 447-455.
- Dillin, A., Crawford, D.K., and Kenyon, C. (2002). Timing requirements for insulin/IGF-1 signaling in *C. elegans*. *Science* 298, 830-834.
- D'Mello, N.P., Childress, A.M., Franklin, D.S., Kale, S.P., Pinswasdi, C., and Jazwinski, S.M. (1994). Cloning and characterization of LAG1, a longevity-assurance gene in yeast. *J Biol Chem* 269, 15451-15459.
- Drummen, G.P. (2000). *The Bioremediation of Antioxidants*, Utrecht, Utrecht.
- Drummen, G.P., van Liebergen, L.C., Op den Kamp, J.A., and Post, J.A. (2002). C11-BODIPY(581/591), an oxidation-sensitive fluorescent lipid peroxidation probe: (micro)spectroscopic characterization and validation of methodology. *Free Radic Biol Med* 33, 473-490.
- Egilmez, N.K., Chen, J.B., and Jazwinski, S.M. (1990). Preparation and partial characterization of old yeast cells. *J Gerontol* 45, B9-17.
- Ezaki, B., Gardner, R.C., Ezaki, Y., Kondo, H., and Matsumoto, H. (1998). Protective roles of two aluminum (Al)-induced genes, HSP150 and SED1 of *Saccharomyces cerevisiae*, in Al and oxidative stresses. *FEMS Microbiol Lett* 159, 99-105.
- Fabrizio, P., Liou, L.L., Moy, V.N., Diaspro, A., SelverstoneValentine, J., Gralla, E.B., and Longo, V.D. (2003). SOD2 functions downstream of Sch9 to extend longevity in yeast. *Genetics* 163, 35-46.
- Fabrizio, P., Pozza, F., Pletcher, S.D., Gendron, C.M., and Longo, V.D. (2001). Regulation of longevity and stress resistance by Sch9 in yeast. *Science* 292, 288-290.
- Flattery-O'Brien, J.A., and Dawes, I.W. (1998). Hydrogen peroxide causes RAD9-dependent cell cycle arrest in G2 in *Saccharomyces cerevisiae* whereas menadione causes G1 arrest independent of RAD9 function. *J Biol Chem* 273, 8564-8571.
- Forsburg, S.L., and Guarente, L. (1989). Identification and characterization of HAP4: a third component of the CCAAT-bound HAP2/HAP3 heteromer. *Genes Dev* 3, 1166-1178.
- Fridovich, I. (1975). Superoxide dismutases. *Annu Rev Biochem* 44, 147-159.
- Frohlich, K.U., and Madeo, F. (2000). Apoptosis in yeast--a monocellular organism exhibits altruistic behaviour. *FEBS Lett* 473, 6-9.

- Gasch, A.P., Spellman, P.T., Kao, C.M., Carmel-Harel, O., Eisen, M.B., Storz, G., Botstein, D., and Brown, P.O. (2000). Genomic expression programs in the response of yeast cells to environmental changes. *Mol Biol Cell* 11, 4241-4257.
- Gershon, H., and Gershon, D. (2000). The budding yeast, *saccharomyces cerevisiae*, as a model for aging research: a critical review. *Mech Ageing Dev* 120, 1-22.
- Geymonat, M., Wang, L., Garreau, H., and Jacquet, M. (1998). Ssa1p chaperone interacts with the guanine nucleotide exchange factor of ras Cdc25p and controls the cAMP pathway in *Saccharomyces cerevisiae*. *Mol Microbiol* 30, 855-864.
- GISSI. (1999). Dietary supplementation with n-3 polyunsaturated fatty acids and vitamin E after myocardial infarction: results of the GISSI-Prevenzione trial. *Lancet* 354, 447-455.
- Godon, C., Lagniel, G., Lee, J., Buhler, J.M., Kieffer, S., Perrot, M., Boucherie, H., Toledano, M.B., and Labarre, J. (1998). The H<sub>2</sub>O<sub>2</sub> stimulon in *Saccharomyces cerevisiae*. *J Biol Chem* 273, 22480-22489.
- Grant, C.M., Collinson, L.P., Roe, J.H., and Dawes, I.W. (1996a). Yeast glutathione reductase is required for protection against oxidative stress and is a target gene for yAP-1 transcriptional regulation. *Mol Microbiol* 21, 171-179.
- Grant, C.M., MacIver, F.H., and Dawes, I.W. (1996b). Glutathione is an essential metabolite required for resistance to oxidative stress in the yeast *Saccharomyces cerevisiae*. *Curr Genet* 29, 511-515.
- Grant, C.M., Perrone, G., and Dawes, I.W. (1998). Glutathione and catalase provide overlapping defenses for protection against hydrogen peroxide in the yeast *Saccharomyces cerevisiae*. *Biochem Biophys Res Commun* 253, 893-898.
- Griffioen, G., Swinnen, S., and Thevelein, J.M. (2003). Feedback inhibition on cell wall integrity signaling by Zds1 involves Gsk3 phosphorylation of a cAMP-dependent protein kinase regulatory subunit. *J Biol Chem* 278, 23460-23471.
- Grzelak, A., Skierski, J., and Bartosz, G. (2001). Decreased antioxidant defense during replicative aging of the yeast *Saccharomyces cerevisiae* studied using the 'baby machine' method. *FEBS Lett* 492, 123-126.
- Hardwick, K.G., Lewis, M.J., Semenza, J., Dean, N., and Pelham, H.R. (1990). ERD1, a yeast gene required for the retention of luminal endoplasmic reticulum proteins, affects glycoprotein processing in the Golgi apparatus. *Embo J* 9, 623-630.
- Harman, D. (1956). Aging: a theory based on free radical and radiation chemistry. *Journal of Gerontology* 11, 298-300.
- Hart, P.J., Balbirnie, M.M., Ogihara, N.L., Nersissian, A.M., Weiss, M.S., Valentine, J.S., and Eisenberg, D. (1999). A structure-based mechanism for copper-zinc superoxide dismutase. *Biochemistry* 38, 2167-2178.
- Hartwell, L.H., Culotti, J., Pringle, J.R., and Reid, B.J. (1974). Genetic control of the cell division cycle in yeast. *Science* 183, 46-51.
- Hasan, R., Leroy, C., Isnard, A.D., Labarre, J., Boy-Marcotte, E., and Toledano, M.B. (2002). The control of the yeast H<sub>2</sub>O<sub>2</sub> response by the Msn2/4 transcription factors. *Mol Microbiol* 45, 233-241.
- Hassett, R., and Kosman, D.J. (1995). Evidence for Cu(II) reduction as a component of copper uptake by *Saccharomyces cerevisiae*. *J Biol Chem* 270, 128-134.
- Hayflick, L. (2000). The future of ageing. *Nature* 408, 267-269.

- Heilbronn, L.K., and Ravussin, E. (2003). Calorie restriction and aging: review of the literature and implications for studies in humans. *Am J Clin Nutr* 78, 361-369.
- Helmstetter, C.E. (1991). Description of a baby machine for *Saccharomyces cerevisiae*. *New Biol* 3, 1089-1096.
- Herman, P.K. (2002). Stationary phase in yeast. *Curr Opin Microbiol* 5, 602-607.
- Hoopes, L.L., Budd, M., Choe, W., Weitao, T., and Campbell, J.L. (2002). Mutations in DNA replication genes reduce yeast life span. *Mol Cell Biol* 22, 4136-4146.
- Huang, L.C., Clarkin, K.C., and Wahl, G.M. (1996). Sensitivity and selectivity of the DNA damage sensor responsible for activating p53-dependent G1 arrest. *Proc Natl Acad Sci U S A* 93, 4827-4832.
- Hughes, K.A., Alipaz, J.A., Drnevich, J.M., and Reynolds, R.M. (2002). A test of evolutionary theories of aging. *Proc Natl Acad Sci U S A* 99, 14286-14291.
- Inoue, Y., Matsuda, T., Sugiyama, K., Izawa, S., and Kimura, A. (1999). Genetic analysis of glutathione peroxidase in oxidative stress response of *Saccharomyces cerevisiae*. *J Biol Chem* 274, 27002-27009.
- Irniger, S., and Nasmyth, K. (1997). The anaphase-promoting complex is required in G1 arrested yeast cells to inhibit B-type cyclin accumulation and to prevent uncontrolled entry into S-phase. *J Cell Sci* 110, 1523-1531.
- Ito, T., Chiba, T., Ozawa, R., Yoshida, M., Hattori, M., and Sakaki, Y. (2001). A comprehensive two-hybrid analysis to explore the yeast protein interactome. *Proc Natl Acad Sci U S A* 98, 4569-4574.
- Jakubowski, W., Bilinski, T., and Bartosz, G. (2000). Oxidative stress during aging of stationary cultures of the yeast *Saccharomyces cerevisiae*. *Free Radic Biol Med* 28, 659-664.
- Jazwinski, S.M. (1999). Molecular mechanisms of yeast longevity. *Trends Microbiol* 7, 247-252.
- Jazwinski, S.M. (2001). New clues to old yeast. *Mech Ageing Dev* 122, 865-882.
- Jazwinski, S.M., Egilmez, N.K., and Chen, J.B. (1989). Replication control and cellular life span. *Exp Gerontol* 24, 423-436.
- Jeong, J.S., Kwon, S.J., Kang, S.W., Rhee, S.G., and Kim, K. (1999). Purification and characterization of a second type thioredoxin peroxidase (type II TPx) from *Saccharomyces cerevisiae*. *Biochemistry* 38, 776-783.
- Jiang, J.C., Jaruga, E., Repnevskaya, M.V., and Jazwinski, S.M. (2000). An intervention resembling caloric restriction prolongs life span and retards aging in yeast. *Faseb J* 14, 2135-2137.
- Jiang, J.C., Wawryn, J., Shantha Kumara, H.M., and Jazwinski, S.M. (2002). Distinct roles of processes modulated by histone deacetylases Rpd3p, Hda1p, and Sir2p in life extension by caloric restriction in yeast. *Exp Gerontol* 37, 1023-1030.
- Johnston, S.D., Enomoto, S., Schnepfer, L., McClellan, M.C., Twu, F., Montgomery, N.D., Haney, S.A., Broach, J.R., and Berman, J. (2001). CAC3(MSI1) suppression of RAS2(G19V) is independent of chromatin assembly factor I and mediated by NPR1. *Mol Cell Biol* 21, 1784-1794.
- Jorgensen, P., Nishikawa, J.L., Breikreutz, B.J., and Tyers, M. (2002). Systematic identification of pathways that couple cell growth and division in yeast. *Science* 297, 395-400.
- Kaeberlein, M., Andalis, A.A., Fink, G.R., and Guarente, L. (2002). High osmolarity extends life span in *Saccharomyces cerevisiae* by a mechanism related to caloric restriction. *Mol Cell Biol* 22, 8056-8066.

- Kaeberlein, M., and Guarente, L. (2002). Saccharomyces cerevisiae MPT5 and SSD1 function in parallel pathways to promote cell wall integrity. *Genetics* 160, 83-95.
- Kaeberlein, M., McVey, M., and Guarente, L. (1999). The SIR2/3/4 complex and SIR2 alone promote longevity in Saccharomyces cerevisiae by two different mechanisms. *Genes Dev* 13, 2570-2580.
- Kennedy, B.K., Austriaco, N.R., Jr., and Guarente, L. (1994). Daughter cells of Saccharomyces cerevisiae from old mothers display a reduced life span. *J Cell Biol* 127, 1985-1993.
- Kennedy, B.K., Austriaco, N.R., Jr., Zhang, J., and Guarente, L. (1995). Mutation in the silencing gene SIR4 can delay aging in S. cerevisiae. *Cell* 80, 485-496.
- Kenyon, C. (2001). A conserved regulatory system for aging. *Cell* 105, 165-168.
- Kim, S., Benguria, A., Lai, C.Y., and Jazwinski, S.M. (1999). Modulation of life-span by histone deacetylase genes in Saccharomyces cerevisiae. *Mol Biol Cell* 10, 3125-3136.
- Kirkwood, T.B. (2002). Evolution of ageing. *Mech Ageing Dev* 123, 737-745.
- Kirkwood, T.B., and Austad, S.N. (2000). Why do we age? *Nature* 408, 233-238.
- Kirkwood, T.B., and Holliday, R. (1979). The evolution of ageing and longevity. *Proc R Soc Lond B Biol Sci* 205, 531-546.
- Kolodner, R.D., Putnam, C.D., and Myung, K. (2002). Maintenance of genome stability in Saccharomyces cerevisiae. *Science* 297, 552-557.
- Ku, H.H., Brunk, U.T., and Sohal, R.S. (1993). Relationship between mitochondrial superoxide and hydrogen peroxide production and longevity of mammalian species. *Free Radic Biol Med* 15, 621-627.
- Kuge, S., and Jones, N. (1994). YAP1 dependent activation of TRX2 is essential for the response of Saccharomyces cerevisiae to oxidative stress by hydroperoxides. *Embo J* 13, 655-664.
- Kumar, A., Agarwal, S., Heyman, J.A., Matson, S., Heidtman, M., Piccirillo, S., Umansky, L., Drawid, A., Jansen, R., Liu, Y., Cheung, K.H., Miller, P., Gerstein, M., Roeder, G.S., and Snyder, M. (2002). Subcellular localization of the yeast proteome. *Genes Dev* 16, 707-719.
- Landry, J., Sutton, A., Tafrov, S.T., Heller, R.C., Stebbins, J., Pillus, L., and Sternglanz, R. (2000). The silencing protein SIR2 and its homologs are NAD-dependent protein deacetylases. *Proc Natl Acad Sci U S A* 97, 5807-5811.
- Laun, P., Pichova, A., Madeo, F., Fuchs, J., Ellinger, A., Kohlwein, S., Dawes, I., Frohlich, K.U., and Breitenbach, M. (2001). Aged mother cells of Saccharomyces cerevisiae show markers of oxidative stress and apoptosis. *Mol Microbiol* 39, 1166-1173.
- Lee, C.K., Klopp, R.G., Weindruch, R., and Prolla, T.A. (1999a). Gene Expression Profile of Aging and Its Retardation by Caloric Restriction. *Science* 285, 1390-1393.
- Lee, J., Godon, C., Lagniel, G., Spector, D., Garin, J., Labarre, J., and Toledano, M.B. (1999b). Yap1 and Skn7 control two specialized oxidative stress response regulons in yeast. *J Biol Chem* 274, 16040-16046.
- Leggett, D.S., Hanna, J., Borodovsky, A., Crosas, B., Schmidt, M., Baker, R.T., Walz, T., Ploegh, H., and Finley, D. (2002). Multiple associated proteins regulate proteasome structure and function. *Mol Cell* 10, 495-507.
- Lin, S.J., Defossez, P.A., and Guarente, L. (2000). Requirement of NAD and SIR2 for life-span extension by calorie restriction in Saccharomyces cerevisiae. *Science* 289, 2126-2128.
- Lin, S.J., and Guarente, L. (2003). Nicotinamide adenine dinucleotide, a metabolic regulator of transcription, longevity and disease. *Curr Opin Cell Biol* 15, 241-246.

- Lin, S.J., Kaeberlein, M., Andalis, A.A., Sturtz, L.A., Defossez, P.A., Culotta, V.C., Fink, G.R., and Guarente, L. (2002). Calorie restriction extends *Saccharomyces cerevisiae* lifespan by increasing respiration. *Nature* *418*, 344-348.
- Lin, S.S., Manchester, J.K., and Gordon, J.I. (2001). Enhanced gluconeogenesis and increased energy storage as hallmarks of aging in *Saccharomyces cerevisiae*. *J Biol Chem* *276*, 36000-36007.
- Livingstone, S.D., and Kuehn, L.A. (1979). Similarity in the number of lifespan heartbeats among non-hibernating homeothermic animals. *Aviat Space Environ Med* *50*, 1037-1039.
- Longo, V.D. (1999). Mutations in signal transduction proteins increase stress resistance and longevity in yeast, nematodes, fruit flies, and mammalian neuronal cells. *Neurobiol Aging* *20*, 479-486.
- Longo, V.D. (2003). The Ras and Sch9 pathways regulate stress resistance and longevity. *Exp Gerontol* *38*, 807-811.
- Longo, V.D., Gralla, E.B., and Valentine, J.S. (1996). Superoxide dismutase activity is essential for stationary phase survival in *Saccharomyces cerevisiae*. Mitochondrial production of toxic oxygen species in vivo. *J Biol Chem* *271*, 12275-12280.
- Madeo, F., Frohlich, E., Ligr, M., Grey, M., Sigrist, S.J., Wolf, D.H., and Frohlich, K.U. (1999). Oxygen stress: A regulator of apoptosis in yeast. *J Cell Biol* *145*, 757-767.
- Mandavilli, B.S., Santos, J.H., and Van Houten, B. (2002). Mitochondrial DNA repair and aging. *Mutat Res* *509*, 127-151.
- Marsischky, G.T., Filosi, N., Kane, M.F., and Kolodner, R. (1996). Redundancy of *Saccharomyces cerevisiae* MSH3 and MSH6 in MSH2-dependent mismatch repair. *Genes Dev* *10*, 407-420.
- Martinez Munoz, C., van Meeteren, L.A., Post, J.A., Verkleij, A.J., Verrips, C.T., and Boonstra, J. (2002). Hydrogen peroxide inhibits cell cycle progression by inhibition of the spreading of mitotic CHO cells. *Free Radic Biol Med* *33*, 1061-1072.
- Martinez-Pastor, M.T., Marchler, G., Schuller, C., Marchler-Bauer, A., Ruis, H., and Estruch, F. (1996). The *Saccharomyces cerevisiae* zinc finger proteins Msn2p and Msn4p are required for transcriptional induction through the stress response element (STRE). *Embo J* *15*, 2227-2235.
- Masoro, E.J. (1998). Hormesis and the antiaging action of dietary restriction. *Exp Gerontol* *33*, 61-66.
- McAlister, L., and Holland, M.J. (1985). Differential expression of the three yeast glyceraldehyde-3-phosphate dehydrogenase genes. *J Biol Chem* *260*, 15019-15027.
- McCay, C.M., Crowell, M.F., and Maynard, L.A. (1935). The effect of retarded growth upon the length of life and upon the ultimate body size. *Journal of Nutrition* *10*, 63-79.
- Melov, S., Ravenscroft, J., Malik, S., Gill, M.S., Walker, D.W., Clayton, P.E., Wallace, D.C., Malfroy, B., Doctrow, S.R., and Lithgow, G.J. (2000). Extension of life-span with superoxide dismutase/catalase mimetics. *Science* *289*, 1567-1569.
- Menon, A.K., and Stevens, V.L. (1992). Phosphatidylethanolamine is the donor of the ethanolamine residue linking a glycosylphosphatidylinositol anchor to protein. *J Biol Chem* *267*, 15277-15280.
- Mimura, G., Murakami, K., and Gushiken, M. (1992). Nutritional factors for longevity in Okinawa--present and future. *Nutr Health* *8*, 159-163.
- Moll, R., and Wintersberger, E. (1976). Synthesis of yeast histones in the cell cycle. *Proc Natl Acad Sci U S A* *73*, 1863-1867.

- Momose, Y., and Iwahashi, H. (2001). Bioassay of cadmium using a DNA microarray: genome-wide expression patterns of *Saccharomyces cerevisiae* response to cadmium. *Environ Toxicol Chem* 20, 2353-2360.
- Moradas-Ferreira, P., Costa, V., Piper, P., and Mager, W. (1996). The molecular defences against reactive oxygen species in yeast. *Mol Microbiol* 19, 651-658.
- Morgan, B.A., Banks, G.R., Toone, W.M., Raitt, D., Kuge, S., and Johnston, L.H. (1997). The Skn7 response regulator controls gene expression in the oxidative stress response of the budding yeast *Saccharomyces cerevisiae*. *Embo J* 16, 1035-1044.
- Mortimer, R.K., and Johnston, J.R. (1959). Life span of individual yeast cells. *Nature* 183, 1751-1752.
- Motizuki, M., and Tsurugi, K. (1992). The effect of aging on protein synthesis in the yeast *Saccharomyces cerevisiae*. *Mech Ageing Dev* 64, 235-245.
- Muller, E.G. (1991). Thioredoxin deficiency in yeast prolongs S phase and shortens the G1 interval of the cell cycle. *J Biol Chem* 266, 9194-9202.
- Nakanishi, T., and Sekimizu, K. (2002). SDT1/SSM1, a multicopy suppressor of S-II null mutant, encodes a novel pyrimidine 5'-nucleotidase. *J Biol Chem* 277, 22103-22106.
- Nakashima, N., Noguchi, E., and Nishimoto, T. (1999). *Saccharomyces cerevisiae* putative G protein, Gtr1p, which forms complexes with itself and a novel protein designated as Gtr2p, negatively regulates the Ran/Gsp1p G protein cycle through Gtr2p. *Genetics* 152, 853-867.
- Nathan, C. (2003). Specificity of a third kind: reactive oxygen and nitrogen intermediates in cell signaling. *J Clin Invest* 111, 769-778.
- Norbeck, J., and Blomberg, A. (2000). The level of cAMP-dependent protein kinase A activity strongly affects osmotolerance and osmo-instigated gene expression changes in *Saccharomyces cerevisiae*. *Yeast* 16, 121-137.
- Nystrom, T. (2002). Aging in bacteria. *Curr Opin Microbiol* 5, 596-601.
- Ohtake, Y., and Yabuuchi, S. (1991). Molecular cloning of the gamma-glutamylcysteine synthetase gene of *Saccharomyces cerevisiae*. *Yeast* 7, 953-961.
- Oku, K., Watanabe, H., Kubota, M., Fukuda, S., Kurimoto, M., Tsujisaka, Y., Komori, M., Inoue, Y., and Sakurai, M. (2003). NMR and Quantum Chemical Study on the OH...pi and CH...O Interactions between Trehalose and Unsaturated Fatty Acids: Implication for the Mechanism of Antioxidant Function of Trehalose. *J Am Chem Soc* 125, 12739-12748.
- Omenn, G.S., Goodman, G.E., Thornquist, M.D., Balmes, J., Cullen, M.R., Glass, A., Keogh, J.P., Meyskens, F.L., Valanis, B., Williams, J.H., Barnhart, S., and Hammar, S. (1996). Effects of a combination of beta carotene and vitamin A on lung cancer and cardiovascular disease. *N Engl J Med* 334, 1150-1155.
- Orr, W.C., and Sohal, R.S. (1994). Extension of life-span by overexpression of superoxide dismutase and catalase in *Drosophila melanogaster*. *Science* 263, 1128-1130.
- Paalman, J.W., Verwaal, R., Slofstra, S.H., Verkleij, A.J., Boonstra, J., and Verrips, C.T. (2003). Trehalose and glycogen accumulation is related to the duration of the G1 phase of *Saccharomyces cerevisiae*. *FEMS Yeast Res* 3, 261-268.
- Palmieri, L., Voza, A., Agrimi, G., De Marco, V., Runswick, M.J., Palmieri, F., and Walker, J.E. (1999). Identification of the yeast mitochondrial transporter for oxaloacetate and sulfate. *J Biol Chem* 274, 22184-22190.

- Park, S.G., Cha, M.K., Jeong, W., and Kim, I.H. (2000). Distinct physiological functions of thiol peroxidase isoenzymes in *Saccharomyces cerevisiae*. *J Biol Chem* 275, 5723-5732.
- Pedrajas, J.R., Kosmidou, E., Miranda-Vizuete, A., Gustafsson, J.A., Wright, A.P., and Spyrou, G. (1999). Identification and functional characterization of a novel mitochondrial thioredoxin system in *Saccharomyces cerevisiae*. *J Biol Chem* 274, 6366-6373.
- Polevoda, B., Norbeck, J., Takakura, H., Blomberg, A., and Sherman, F. (1999). Identification and specificities of N-terminal acetyltransferases from *Saccharomyces cerevisiae*. *Embo J* 18, 6155-6168.
- Rahman, I., Gilmour, P.S., Jimenez, L.A., and MacNee, W. (2002). Oxidative stress and TNF-alpha induce histone acetylation and NF- $\kappa$ B/AP-1 activation in alveolar epithelial cells: potential mechanism in gene transcription in lung inflammation. *Mol Cell Biochem* 234-235, 239-248.
- Rice-Evans, C.A., and Burdon, R.H. (1994). *Free Radical Damage and its Control*. Elsevier: Amsterdam.
- Rolland, F., Winderickx, J., and Thevelein, J.M. (2002). Glucose-sensing and -signalling mechanisms in yeast. *FEM Yeast Res* 2, 183-201.
- Roy, N., and Runge, K.W. (2000). Two paralogs involved in transcriptional silencing that antagonistically control yeast life span. *Curr Biol* 10, 111-114.
- Sambrook, J., Fritsch, E.F., and Maniatis, T. (1989). *Molecular Cloning, a laboratory manual*. Cold Spring Harbor Laboratory Press: Woodbury NY.
- Schoondermark-Stolk, S.A., ter Schure, E.G., Verrips, C.T., Verkleij, A.J., and Boonstra, J. (2002). Identification of salt-induced genes of *Zygosaccharomyces rouxii* by using *Saccharomyces cerevisiae* GeneFilters(R). *FEM Yeast Res* 2, 525-532.
- Shama, S., Lai, C.Y., Antoniazzi, J.M., Jiang, J.C., and Jazwinski, S.M. (1998). Heat stress-induced life span extension in yeast. *Exp Cell Res* 245, 379-388.
- Shenton, D., Perrone, G., Quinn, K.A., Dawes, I.W., and Grant, C.M. (2002). Regulation of protein S-thiolation by glutaredoxin 5 in the yeast *Saccharomyces cerevisiae*. *J Biol Chem* 277, 16853-16859.
- Silles, E., Mazon, M.J., Gevaert, K., Goethals, M., Vandekerckhove, J., Leber, R., and Sandoval, I.V. (2000). Targeting of aminopeptidase I to the yeast vacuole is mediated by Ssa1p, a cytosolic member of the 70-kDa stress protein family. *J Biol Chem* 275, 34054-34059.
- Silljé, H.H., Paalman, J.W., ter Schure, E.G., Olsthoorn, S.Q., Verkleij, A.J., Boonstra, J., and Verrips, C.T. (1999). Function of trehalose and glycogen in cell cycle progression and cell viability in *Saccharomyces cerevisiae*. *J Bacteriol* 181, 396-400.
- Silljé, H.H., ter Schure, E.G., Rommens, A.J., Huls, P.G., Woldringh, C.L., Verkleij, A.J., Boonstra, J., and Verrips, C.T. (1997). Effects of different carbon fluxes on G1 phase duration, cyclin expression, and reserve carbohydrate metabolism in *Saccharomyces cerevisiae*. *J Bacteriol* 179, 6560-6565.
- Sinclair, D., Mills, K., and Guarente, L. (1998a). Aging in *Saccharomyces cerevisiae*. *Annu Rev Microbiol* 52, 533-560.
- Sinclair, D.A., and Guarente, L. (1997). Extrachromosomal rDNA circles--a cause of aging in yeast. *Cell* 91, 1033-1042.
- Sinclair, D.A., Mills, K., and Guarente, L. (1998b). Molecular mechanisms of yeast aging. *Trends Biochem Sci* 23, 131-134.

- Smeal, T., Claus, J., Kennedy, B., Cole, F., and Guarente, L. (1996). Loss of transcriptional silencing causes sterility in old mother cells of *S. cerevisiae*. *Cell* 84, 633-642.
- Smith, A., Ward, M.P., and Garrett, S. (1998). Yeast PKA represses Msn2p/Msn4p-dependent gene expression to regulate growth, stress response and glycogen accumulation. *Embo J* 17, 3556-3564.
- Sohal, R.S., Mockett, R.J., and Orr, W.C. (2002). Mechanisms of aging: an appraisal of the oxidative stress hypothesis. *Free Radic Biol Med* 33, 575-586.
- Sohal, R.S., and Weindruch, R. (1996). Oxidative stress, caloric restriction, and aging. *Science* 273, 59-63.
- Souza, A.C., De Mesquita, J.F., Panek, A.D., Silva, J.T., and Paschoalin, V.M. (2002). Evidence for a modulation of neutral trehalase activity by Ca<sup>2+</sup> and cAMP signaling pathways in *Saccharomyces cerevisiae*. *Braz J Med Biol Res* 35, 11-16.
- Spellman, P.T., Sherlock, G., Zhang, M.Q., Iyer, V.R., Anders, K., Eisen, M.B., Brown, P.O., Botstein, D., and Futcher, B. (1998). Comprehensive identification of cell cycle-regulated genes of the yeast *Saccharomyces cerevisiae* by microarray hybridization. *Mol Biol Cell* 9, 3273-3297.
- Stephen, D.W., Rivers, S.L., and Jamieson, D.J. (1995). The role of the YAP1 and YAP2 genes in the regulation of the adaptive oxidative stress responses of *Saccharomyces cerevisiae*. *Mol Microbiol* 16, 415-423.
- Stephen, D.W.S., and Jamieson, D.J. (1996). Glutathione is an important antioxidant molecule in the yeast *Saccharomyces cerevisiae*. *FEMS microbiology letters* 141, 202-212.
- Stephens, N.G., Parsons, A., Schofield, P.M., Kelly, F., Cheeseman, K., and Mitchinson, M.J. (1996). Randomised controlled trial of vitamin E in patients with coronary disease: Cambridge Heart Antioxidant Study (CHAOS). *Lancet* 347, 781-786.
- Sun, J., Kale, S.P., Childress, A.M., Pinswasdi, C., and Jazwinski, S.M. (1994). Divergent roles of RAS1 and RAS2 in yeast longevity. *J Biol Chem* 269, 18638-18645.
- Swiecilo, A., Krawiec, Z., Wawryn, J., Bartosz, G., and Bilinski, T. (2000). Effect of stress on the life span of the yeast *Saccharomyces cerevisiae*. *Acta Biochim Pol* 47, 355-364.
- Tam, A., Schmidt, W.K., and Michaelis, S. (2001). The multispanning membrane protein Ste24p catalyzes CAAX proteolysis and NH<sub>2</sub>-terminal processing of the yeast a-factor precursor. *J Biol Chem* 276, 46798-46806.
- Tatar, M., Kopelman, A., Epstein, D., Tu, M.P., Yin, C.M., and Garofalo, R.S. (2001). A mutant *Drosophila* insulin receptor homolog that extends life-span and impairs neuroendocrine function. *Science* 292, 107-110.
- Thevelein, J.M., and de Winde, J.H. (1999). Novel sensing mechanisms and targets for the cAMP-protein kinase A pathway in the yeast *Saccharomyces cerevisiae*. *Mol Microbiol* 33, 904-918.
- Tomitori, H., Kashiwagi, K., Asakawa, T., Kakinuma, Y., Michael, A.J., and Igarashi, K. (2001). Multiple polyamine transport systems on the vacuolar membrane in yeast. *Biochem J* 353, 681-688.
- Treger, J.M., and McEntee, K. (1990). Structure of the DNA damage-inducible gene DDR48 and evidence for its role in mutagenesis in *Saccharomyces cerevisiae*. *Mol Cell Biol* 10, 3174-3184.
- Tsai, C.S., and Godin, J.R. (1987). Multifunctional activities of yeast glutathione reductase. *Int J Biochem* 19, 337-343.
- van Helden, J., Andre, B., and Collado-Vides, J. (2000). A web site for the computational analysis of yeast regulatory sequences. *Yeast* 16, 177-187.



- Verrips, C.T. (2003). Impact of nutrients on the cell cycle. In: G1 Phase Progression, ed. J. Boonstra, Gergetown, Texas: Landes Bioscience / Eurekah.com, 125-147.
- Verwaal, R. (2003). Growth rate-regulated expression of the hexose transporter HXT5 in *Saccharomyces cerevisiae*, Universiteit Utrecht, Utrecht.
- Verwaal, R., Paalman, J.W., Hogenkamp, A., Verkleij, A.J., Verrips, C.T., and Boonstra, J. (2002). HXT5 expression is determined by growth rates in *Saccharomyces cerevisiae*. *Yeast* 19, 1029-1038.
- Wawryn, J., Swiecilo, A., Bartosz, G., and Bilinski, T. (2002). Effect of superoxide dismutase deficiency on the life span of the yeast *Saccharomyces cerevisiae*. An oxygen-independent role of Cu,Zn-superoxide dismutase. *Biochim Biophys Acta* 1570, 199-202.
- Wei, Y.H., and Lee, H.C. (2002). Oxidative stress, mitochondrial DNA mutation, and impairment of antioxidant enzymes in aging. *Exp Biol Med* (Maywood) 227, 671-682.
- Westendorp, R.G., and Kirkwood, T.B. (1998). Human longevity at the cost of reproductive success. *Nature* 396, 743-746.
- WHO. (2002). THE World Health Report 2002. World Health Organisation, Geneva.
- Woldringh, C.L., Fluiter, K., and Huls, P.G. (1995). Production of senescent cells of *Saccharomyces cerevisiae* by centrifugal elutriation. *Yeast* 11, 361-369.
- Yun, C.W., Ferea, T., Rashford, J., Ardon, O., Brown, P.O., Botstein, D., Kaplan, J., and Philpott, C.C. (2000a). Desferrioxamine-mediated iron uptake in *Saccharomyces cerevisiae*. Evidence for two pathways of iron uptake. *J Biol Chem* 275, 10709-10715.
- Yun, C.W., Tiedeman, J.S., Moore, R.E., and Philpott, C.C. (2000b). Siderophore-iron uptake in *saccharomyces cerevisiae*. Identification of ferrichrome and fusarinine transporters. *J Biol Chem* 275, 16354-16359.
- Zhang, P., and Omaye, S.T. (2001). Antioxidant and prooxidant roles for beta-carotene, alpha-tocopherol and ascorbic acid in human lung cells. *Toxicol In Vitro* 15, 13-24.
- Zhu, H., Klemic, J.F., Chang, S., Bertone, P., Casamayor, A., Klemic, K.G., Smith, D., Gerstein, M., Reed, M.A., and Snyder, M. (2000). Analysis of yeast protein kinases using protein chips. *Nat Genet* 26, 283-289.
- Zimmer, C. (2001). *Evolution, the Triumph of an Idea*. HarperCollins Publishers: New York.





*Nederlandse samenvatting*

## Nederlandse samenvatting

Veroudering is een fenomeen dat wetenschappers al eeuwen heeft bezig gehouden. Er is in de loop der tijd ook al het één en ander ontdekt, maar een definitief antwoord op de vraag waarom biologische systemen zoals de mens verouderen, is er nog niet. Er zijn een aantal ‘uitdagingen’ met betrekking tot het onderzoeken van veroudering. Het probleem met onderzoek in de mens zelf is dat de levensomstandigheden zelden goed gedefinieerd en constant zijn, en dat het proces van veroudering lang duurt. Om een idee te krijgen over de fundamentele cellulaire principes van veroudering kan echter ook met modelorganismen gewerkt worden (zie ook hoofdstuk 1). Eén van die modelorganismen is de gist *Saccharomyces cerevisiae*. Dit is een eencellige schimmel die al veelvuldig gebruikt is om essentiële biologische processen zoals bijvoorbeeld celdeling, te onderzoeken. Een proces als veroudering is alleen van toepassing op organismen waarbij er een duidelijk verschil is tussen de ‘ouder’ en de ‘nakomeling’. *S.cerevisiae* voldoet aan dit criterium want de dochtercel die wordt geproduceerd door de moedercel is kleiner en na deling blijft er op de celwand van de moedercel een lidteken achter. Bijkomend voordeel is dat dit lidteken specifiek is te kleuren en onder een microscoop zichtbaar is. Het gebruik van *S.cerevisiae* bij verouderingsonderzoek heeft een aantal belangrijke voordelen zoals de controleerbaarheid van de groeiomstandigheden en het feit dat de gisten veel sneller verouderen. Beide eigenschappen zijn, bij het onderzoek beschreven in dit proefschrift, gebruikt om een aantal aspecten van veroudering nader te bekijken.

Het is bekend dat gelimiteerde verstrekking van voedsel aan ratten leidt tot een verlenging van de levensduur. Dit proces, beter bekend als calorie restrictie, treedt ook op in modelorganismen als *S.cerevisiae*. Een goede controle van de groeiomstandigheden waarin de gisten zich bevinden is daarom nodig om correcte conclusies te kunnen trekken. Hoe exact calorie restrictie in staat is de levensduur te verlengen is onduidelijk. In het tweede hoofdstuk wordt beschreven hoe cellen reageren op deze omgevingsomstandigheden, ze maken bijvoorbeeld meer stress eiwitten. Dit zijn eiwitten die cellen helpen om moeilijke periodes door te komen. Het verhogen van de productie van deze stress eiwitten kan geïnitieerd zijn door de langzamere groei die de voedsel limitatie met zich meebrengt, maar kan ook een indirect effect zijn doordat de gistcel zijn energiehuishouding verandert. *S.cerevisiae* kan namelijk op twee verschillende manieren energie genereren, via fermentatie (zonder zuurstof) en via respiratie (met

156

zuurstof). Bij langzame groei omstandigheden verkrijgt de cel zijn energie door respiratie. Bij respiratie kunnen er meer reactieve zuurstofmoleculen ontstaan, zogenaamde zuurstofradicalen, die een stress respons kunnen uitlokken. Die verhoogde stress repons geeft de cel de kans de periode waarin voedsel schaars is te overleven. Blijkbaar levert dit echter op de lange termijn ook een verlenging van de levensduur op. Een verhoogde stress respons is echter niet het enige dat geobserveerd wordt. Ook een verandering in de hoeveelheid nicotinamide zou wel eens belangrijk kunnen zijn voor het bepalen van de levensduur van een gistcel. Dit molecuul is in staat de activiteit van een eiwit genaamd Sir2 te beïnvloeden. Sir2 is belangrijk bij het stabiliseren van het genetische materiaal, het DNA. Langzame groei lijkt de afbraak van nicotinamide te versterken waardoor Sir2 actiever is, waardoor het DNA stabielier blijft. Dit heeft tevens een effect op de levensduur. Niet alleen het limiteren van voedsel, ook het blootstellen aan hogere temperaturen en verhoogde zoutconcentraties kunnen leiden tot een groeivertraging en een langere levensduur. Het lijkt er dus op dat matige stress levensduurverlengend kan werken. Hoe echter de die verschillende soorten stress kunnen leiden tot een verlaging van de groeisnelheid is nog niet helemaal duidelijk. Het lijkt er op dat een bepaald eiwitcomplex dat PKA heet erbij betrokken is. Of dit complex uitgezet wordt door de langzame groei of dat juist de inactivatie van PKA leidt tot een verlaging van de groeisnelheid moet ook nog ontdekt worden.

Eén van de effecten van het limiteren van voedsel is een vertraging van de celcyclus. Dit komt met name tot uiting in de verlenging van één specifieke fase van die celcyclus namelijk de G1-fase. In deze fase bouwt de cel reserves op om de rest van de cyclus door te komen. In het geval dat er weinig bouwstoffen aanwezig zijn dan is het niet zo vreemd dat deze specifieke fase langer duurt dan normaal. Om er achter te komen of de reactie op stressvolle omstandigheden van *S.cerevisiae* in deze fase anders is dan in andere fasen werden verschillende experimenten gedaan beschreven in hoofdstuk drie en vier. Daaruit blijkt dat de eerste reactie (de transcriptionele respons) verschillend is in de verschillende fasen. Tevens blijkt dat de daaropvolgende reactie (de translationele respons) ook afhankelijk is van de fase waarin de cellen zich bevinden. Dit lijkt echter gekoppeld te zijn aan de snelheid waarmee cellen nieuw eiwit kunnen produceren. In beide gevallen laten vooral eiwitten die betrokken zijn bij het thioredoxine systeem een duidelijke stress respons zien.

In het vijfde hoofdstuk werd gekeken naar verschillen tussen jonge en oude cellen en hun reactie op oxidatieve stress. Daarin werd geconcludeerd dat in oude cellen

de stress respons minder is. Dit zou een effect kunnen zijn van een verminderde regulatie van de stress respons. Er is echter geen verschil te zien in levensvatbaarheid van de gistcellen na blootstelling van deze cellen aan zuurstof stress. Door deze oude cellen te supplementeren met krachtige antioxidanten zou hun afweer kunnen versterken. In hoofdstuk zes wordt een screening methode beschreven waarmee met behulp van een reporterconstruct nieuwe potentiële antioxidanten te ontdekken zijn.



*T*hanks & Curriculum vitae

## Bezinksel

Er bestaat geen protocol voor het doorlopen van een promotie maar er zijn wel degelijk een stel randvoorwaarden. Een leuke club mensen om je heen is essentieel en in mijn geval was dat gelukkig ook zo. Terugkijkend op de tijd dat ik bij de vakgroep heb rondgelopen, nog steeds liefkozend EMSA genoemd, kijk ik echter wel naar een heuvelachtig landschap met dus hoogte- en dieptepunten. Dat is echter helemaal niet erg, want zoals Nietzsche reeds schreef ‘Was mich nicht umbringt macht mich stärker’. Denk nu niet dat ik Nietzsche paraat heb om te citeren, maar ik heb wel vrienden die dat kunnen, dus... In ieder geval is het citaat niet alleen van toepassing op het onderwerp van mijn onderzoek (zie bijvoorbeeld de general discussion) maar tevens op het hele promotietraject zelf.

Bij de start van een promotie heb je natuurlijk geen benul waar je je precies mee bezig gaat houden de daaropvolgende vier à vijf jaar. Ook het veld waar je je in gaat begeven en het onderwerp zijn in het begin nog onduidelijk. Mijn achtergrond als chemicus in de faculteit biologie had daarbij zo zijn voor- en nadelen. Een zekere affiniteit voor cijfers, chemicalien en grootheden is naar mijn gevoel meer gecultiveerd dan bij sommige biologen, terwijl ik enkele basisfeiten uit de biologie, zoals tot welke fylum octopussen behoren, niet standaard paraat heb.

Een grensgebied tussen de biologie en de chemie, zoals de celbiologie, trekt natuurlijk mensen aan uit de verschillende disciplines en dat is alleen maar beter voor de kruisbestuiving. Dit is bijvoorbeeld terug te zien bij mijn promotoren. Theo is een biotechnoloog, Johannes is een rasechte bioloog en Arie is meer een chemische bioloog. Dit levert verschillende perspectieven op die elkaar kunnen versterken maar ook soms tot babylonische (spraak)verwarring kunnen leiden. Deze trojka heeft mij om beurten, en soms tegelijk, van goede adviezen en richting voorzien waarvoor veel dank.

Dankwoorden zijn er in vele verschijningsvormen, soms origineel, soms standaard, soms lang en soms kort. Een kleine categorisatie van de dankwoorden in de proefschriften die ik bezit leidt echter wel tot de ontdekking van een aantal patronen. Zo wordt er significant vaak begonnen met de opmerking dat er één naam op de kaft staat maar dat de tot standkoming van het proefschrift niet had kunnen gebeuren zonder de vele anderen die daarna aan bod komen. Een waarheid als een koe, maar die ene naam



heeft het wel mooi allemaal opgeschreven. Maar goed, een greep uit de verschillende categorieën:

Het beknopte dankwoord – ‘iedereen bedankt’

Het zakelijke dankwoord – ‘bedankt professoren’

Het bijzonder volledige dankwoord – ‘bedankt kantinepersoneel en portiers’

Het egocentrische dankwoord – ‘vooral mezelf bedanken’

Het afwezige dankwoord – ‘...’

Het eerlijke dankwoord – ‘bedankt voor het laten vallen van mijn samples’

Het insiders dankwoord – ‘bedankt voor het haar’

Het ondankwoord – ‘ondanks de hulp van...’

Het Michael Moore dankwoord – ‘bedankt Bush’

Het omklede dankwoord – zoals het dankwoord dat u nu leest

Na wikken en wegen heb ik uiteindelijk voor het laatste gekozen, al kon ik het natuurlijk niet laten kleine ‘crispy’ bites te nemen uit de andere categorieën.

Practisch gezien zijn mijn studenten Raoul en Lisa niet alleen bijzonder (hulpv)aardig geweest maar zijn hun stages tegelijkertijd zowel voor henzelf als voor mij een leerzame ervaring gebleken. Ik ben erg in mijn nopjes dat Raoul samen met Fiona een gedeelte van de zenuwen en de organisatie van mijn promotie op zich wil nemen, door als paranimfen (ook wel engelen) te fungeren. Ook Anne-Lies die talloze proeven heeft uitgevoerd om een bruikbare screeningmethode te ontwikkelen voor het project, ben ik zeer erkentelijk.

De minder goed kwantificeerbare grootheid ‘gezelligheid’ vond ik vooral bij mijn kamergenoten Hans, Yvonne, Rene, Sung, Denise en Marc maar zeker ook bij koffietafel sessies met Ilse, Edje, Rinse, Bart, Frits, Ramon, Jan, Irina, Elsa, Wendy en Jord. Ook de rest van mijn (ex-)collega’s hadden ieder hun aandeel in het creëren van een fijne werksfeer, bedankt daarvoor. Verder afdalend langs de hiërarchische ladder (hiërarchie ≠ importantie) komen we bij de studenten van wie ik toch vooral Megumi en Wietske wil noemen als fijne mensen zowel tijdens als buiten werktijd.

De EMSA ligt ingebed in een aantal andere organisaties en samenwerkingsverbanden en ik ben altijd van mening geweest dat je daar ook je neus moet laten zien. Concreet hebben we het dan over AiO-avonden, AiO-retraites, IB-seminars, buitendagen, facultaire colloquia etc. Met veel plezier ben ik daar altijd bij

geweest en wil ik langs deze weg alle mensen van de faculteit Biologie en het Instituut Biomembranen succes toewensen met het afronden van hun promotieonderzoek of het continueren van hun loopbaan (omcirkelen wat van toepassing is). Mijn AiO-mentor Adri wil ik nog speciaal bedanken voor zijn luisterend oor, goede adviezen en dropjes.

Tot de morele steunpilaren die mij de afgelopen jaren geholpen hebben, behoren natuurlijk alle mensen van Scouting Maarn-Maarsbergen (inclusief de vakantiestam), Bartender's Advice (+groupies), de Breul-kliek, mijn scheiko-vriendjes, mijn andere vrienden en vriendinnen met een speciale vermelding voor Myrthe en Anouska en last but not least mijn familie, mijn ouders en zus voor algehele ondersteuning en het eruit halen van de laatste grammatica- en tikfouten. Bedankt!

## Curriculum vitae

De schrijver van dit proefschrift werd geboren op een koude winterdag in 1975 te Zeist. Na een zorgeloze jeugd in het pittoreske Maarn waar de basisschool met goed gevolg doorlopen werd, vervolgde hij zijn opleiding op scholengemeenschap ‘ de Breul’ te Zeist. In 1993 werd daar het VWO diploma met succes behaald. Het opleidingstraject werd direct voortgezet bij de faculteit Scheikunde aan de Universiteit Utrecht. Gaandeweg bleek zijn interesse voornamelijk te liggen in de biologische hoek van de scheikunde. Dit kwam onder andere tot uiting in het doen van stages bij de vakgroep biochemie van lipiden en bij het RIVM te Bilthoven. Tevens werd een cursus chemiedidactiek gevolgd. Na de afronding hiervan in 1999 werd gestart met een promotieonderzoek aan de faculteit Biologie bij de vakgroep Moleculaire celbiologie onder leiding van hoogleraren Theo Verrips, Johannes Boonstra en Arie Verkleij. Dit onderzoek resulteerde in het proefschrift dat nu voor u ligt.

Naast het gevolgde onderwijs en uitgevoerde onderzoek werd altijd een keur aan nevenactiviteiten ondernomen. Verschillende organisatorische functies binnen Scouting Maarn-Maarsbergen, scheikundige faculteitsvereniging ‘Proton’, het Instituut Biomembranen, de redactie van het facultaire maandblad ‘bio-SCOPE’ en tevens spelen en optreden met de band ‘Bartender’s Advice’ kan hij opnemen in zijn curriculum vitae.

