

# **The profile of chronic pain patients attending the Helen Joseph Hospital Pain Management Unit**

Yasmin Mahomed Saleem Mayat

A research report submitted to the Faculty of Health Sciences, University  
of the Witwatersrand, in partial fulfillment of the requirements for the  
degree of

Master of Science in Medicine in the branch of Anaesthesiology

Johannesburg, 2014

## **Declaration**

I, Yasmin Mahomed Saleem Mayat declare that this research report is my own work. It is submitted for the admission to the degree of Master of Science in Medicine in the branch of Anaesthesiology by the University of the Witwatersrand, Johannesburg. It has not been submitted before for any degree or examination at this or any other University.

---

Signature

Signed at: University of the Witwatersrand, Johannesburg

28<sup>th</sup> of August 2014

## Abstract

**BACKGROUND:** Chronic pain is a biopsychosocial phenomenon that can have a profound impact on people's lives. Internationally, chronic pain is being recognised as a health priority. South Africa is a developing country with limited resources that are directed at catering for a growing population where life threatening conditions like Human Immunodeficiency Virus (HIV)/Acquired Immunodeficiency Syndrome (AIDS), violent crimes, and poverty predominate. Auditing the Helen Joseph Hospital Pain Management Unit (HJHPMU) is a step towards addressing the paucity of epidemiological data on chronic pain in South Africa. Clinical records are a basic clinical tool that also serves as a medicolegal document. It is essential that these records are legible and complete.

**AIM:** The aim of this study was to describe the profile of chronic pain patients at the HJHPMU for 2011 and to determine the adequacy of record keeping.

**METHODOLOGY:** A retrospective, contextual, descriptive study design was utilised. A consecutive sampling method was used and the study sample included the HJHPMU database and all files of adult patients that attended the HJHPMU during the period January 2011 to December 2011. Patient files were excluded from the audit if insufficient data were found. Descriptive statistics were used to analyse the data obtained during the study. Frequencies and percentages have been reported. A Chi-squared test was utilised to analyse any association between gender and type of pain.

**RESULTS:** There were 475 patients in the HJHPMU database for the year 2011 and 190 of these patients were excluded from the study due to illegible handwriting, duplication in the HJHPMU database, missing data such as no hospital number recorded, no initials to a surname, or the file not found. This resulted in a study sample of 285 patients. The HJHPMU had 215 (75,44%) pre-existing patients and 70 (24,56%) new patients during the year 2011. The preponderance of patients were in the 41-60 year age group, with 146 (51,23%) patients presenting in this age group. Of the 285 patients in the study, 91 (31,93%) patients were male and 194 (68,07%) were female. The most common complaint was of lower back pain (LBP). There were 97 (34,04%) patients with a diagnosis of spinal pain and 59 (20,70%) with Failed Back Surgery Syndrome (FBSS).

There were 164 patients with a relevant surgical history. This included 46 (28,05%) patients that had been involved in a traumatic event, 47 (16,49%) patients that had surgery other than spinal surgery that was relevant to their pain diagnosis, and 71 patients (43,29%) that

had spinal surgery that was relevant to their diagnosis. A Chi-squared test was performed on the relationship between gender and the type of pain, and a p value of 0.001 was found. When relating the type of pain with age, mixed pain and nociceptive pain was found to be most common in those aged >60 years (n=26), whereas neuropathic pain was found to be most common in the 41-60 year age group (n=43).

**CONCLUSION:** With the limited data from this study, the profile of patients with chronic pain in South Africa seems to not differ grossly from data collected internationally. The most pertinent finding of this study is the inadequacy of record keeping.

# Acknowledgements

My thanks go to the following people:

To my supervisors, Helen Perrie, Professor Eva Frohlich and Juan Scribante for their guidance, support and patience.

To Dr Samantha Russell, who helped inspire this research topic and for her guidance and support.

To the staff of the Helen Joseph Hospital Pain Management Unit for their assistance.

To my family for always believing in me.

And to my dear husband, who has always supported me and made me dream big.

# Table of contents

<b>Declaration</b>	<b>2</b>
<b>Abstract</b>	<b>3</b>
<b>Acknowledgements</b>	<b>5</b>
<b>Table of contents</b>	<b>6</b>
<b>List of Figures</b>	<b>9</b>
<b>List of Tables</b>	<b>10</b>
<b>Abbreviations</b>	<b>11</b>
<b>Chapter One - Overview of the study</b>	<b>12</b>
1.1 Introduction	12
1.2 Background to the study	12
1.3 Problem statement	14
1.4 Aim	14
1.5 Objectives	14
1.6 Research assumptions and definitions	15
1.7 Demarcation of study field	15
1.8 Ethical considerations	16
1.9 Research methodology	16
1.9.1 Research design	16
1.9.2 Study population	16
1.9.3 Study sample	16
1.9.4 Inclusion and exclusion criteria	16
1.9.5 Description of data collection	17
1.9.6 Data Analysis	17
1.10 Significance of the study	17
1.11 Validity and reliability of the study	18
1.13 Project outline	18
1.14 Summary	18
<b>Chapter Two - Literature review</b>	<b>19</b>
2.1 Introduction	19
2.2 The evolution of pain theories	19
2.3 Mechanisms of chronic pain	22
2.4 Classification of chronic pain	23
	6

2.4.1 Nociceptive pain	23
2.4.2 Neuropathic pain	24
2.5 Causes of chronic pain	25
2.5.1 Complex regional pain syndrome	26
2.5.2 Myofascial pain syndrome	28
2.5.3 Chronic lower back pain	28
2.5.4 Failed back surgery syndrome	31
2.6 Chronic pain internationally	32
2.6.1 Prevalence of chronic pain	32
2.6.2 Gender and chronic pain	36
2.6.3 Age and chronic pain	38
2.6.4 Economic impact of chronic pain	40
2.6.5 Impact of chronic pain on the individual	41
2.7 Chronic pain in South Africa	42
2.7.1 Prevalence of chronic pain in South Africa	42
2.7.2 HIV/AIDS and chronic pain	44
2.8 Pain questionnaires	44
2.9 Record keeping	45
2.10 Importance of a clinical audit	46
2.11 Summary	47
<b>Chapter Three - Research Design and Methodology</b>	<b>48</b>
3.1 Introduction	48
3.2 Problem statement	48
3.3 Aim	48
3.4 Objectives	48
3.5 Demarcation of study field	49
3.6 Ethical considerations	49
3.7 Research methodology	49
3.7.1 Research design	49
3.7.2 Study population	50
3.7.3 Study sample	50
3.7.4 Inclusion and exclusion criteria	50
3.7.5. Description of data collection	51
3.7.6 Data Analysis	51
3.9 Validity and reliability of the study	51
3.11 Summary	52

<b>Chapter Four - Results and Discussion</b>	<b>54</b>
4.1 Introduction	53
4.2 Secondary Objective	53
4.2.1 Adequacy of record keeping	53
4.3 Primary Objectives	53
4.3.1 Number of pre-existing and new patients consulted in 2011	53
4.3.2 Demographic profile of patients attending the HJHPMU	54
4.3.3 Presenting complaint of patients	54
4.3.4 Diagnosis	56
4.3.5 Relevant medical history	57
4.3.6 Relevant surgical history	58
4.3.7 Type of pain	59
4.4 Discussion	61
4.5 Summary	65
<b>Chapter Five - Summary, Limitations, Recommendations and Conclusion</b>	<b>66</b>
5.1 Introduction	66
5.2 Summary of the study	66
5.2.1 The aim of the study	66
5.2.2 Objectives of the study	66
5.2.3 Summary of the methodology used in the study	67
5.2.4 Main findings of the study	67
5.3 Limitations of the study	69
5.4 Recommendations from the study	69
5.4.1 Recommendations for clinical practice	69
5.4.2 Recommendations for further research	70
5.5 Conclusion	70
<b>References</b>	<b>71</b>



## Appendices

Appendix I	Declaration of Montreal	79
Appendix II	Approval from Postgraduate Committee	83
Appendix III	Approval from the Human Research Ethics Committee (Medical) of the University of the Witwatersrand	84
Appendix IV	Letter to CEO of Helen Joseph Hospital requesting permission to conduct the study and response	85
Appendix V	Letter to head of Helen Joseph Hospital Pain Management Unit	88
Appendix VI	Data collection sheet	89
Appendix VII	Helen Joseph Hospital Pain Management Unit pain questionnaire	90
Appendix VIII	Recommended data collection sheet	96

## List of Figures

Figure 2.1	Gate Control Theory	20
Figure 2.2	Engel's Model of Illness	22
Figure 2.3	Loeser's Model of Pain	22
Figure 2.4	The pathophysiology of chronic pain	23
Figure 2.5	Effect of chronic pain on daily activities	41
Figure 4.1	The number of patients at HJHPMU presenting with each type of pain	59

## List of Tables

Table 2.1	Etiology based classification of painful peripheral neuropathies	25
Table 2.2	Primary diagnosis of patients attending the Universitas Hospital Pain Management Unit in the Free State, S.A	26
Table 2.3	Budapest clinical diagnostic criteria for CRPS	27
Table 2.4	Differential diagnosis of lower back pain and the percentage of adult lower back pain patients in primary care	30
Table 2.5	Etiology of Failed Back Surgery Syndrome	31
Table 2.6	Summary of international prevalence rates for chronic pain	34
Table 2.7	Summary of chronic pain prevalence rates as per Tsang et al	35
Table 2.8	Summary of functional imaging studies in examining brain responses to somatic noxious stimulation	37
Table 2.9	Summary of age of peak prevalence for chronic pain	38
Table 2.10	Mean cost of each expense related to the treatment of chronic pain	40
Table 4.1	Age and gender distribution of patients at HJHPMU	54
Table 4.2	Presenting complaint of patients at HJHPMU	56
Table 4.3	The diagnosis of patients at HJHPMU	57
Table 4.4	Relevant medical history of patients presenting to HJHPMU	58
Table 4.5	Percentage of patients at HJHPMU with a relevant surgical history	59
Table 4.6	Type of pain related to gender at HJHPMU	60
Table 4.7	Type of pain related to age groups at HJHPMU	61

# Abbreviations

**CLBP:** Chronic lower back pain

**CRPS:** Complex regional pain syndrome

**EFIC:** European Federation of IASP Chapters

**FBSS:** Failed Back Surgery Syndrome

**HIV/AIDS:** Human immunodeficiency virus/Acquired immunodeficiency syndrome

**HJHPMU:** Helen Joseph Hospital Pain Management Unit

**HPCSA:** Health Professions' Council of South Africa

**IASP:** International Association for the Study of Pain

**IOM:** Institute of Medicine

**LBP:** Lower back pain

**MPQ:** McGill Pain Questionnaire

**MPS:** Myofascial pain syndrome

**MTrPs:** Myofascial trigger points

**NSA:** Northern Sydney area

**NSW:** New South Wales

**S.A:** South Africa

**SF-MPQ:** Short form of the McGill Pain Questionnaire

**U.S.A:** United States of America

**WHO:** World Health Organization

# **Chapter One – Overview of the study**

## **1.1 Introduction**

In this chapter, a brief overview and summary regarding this study will be presented. Topics covered include a background to the study, problem statement, aims and objectives, research assumptions, demarcation of the study field, ethical considerations, research methodology, significance of the study, validity and reliability, potential limitations and a summary.

## **1.2 Background to the study**

Chronic pain is a biopsychosocial phenomenon that can have a profound impact on people's lives (1). Pain is defined by the International Association for the Study of Pain (IASP) as “an unpleasant sensory and emotional experience associated with actual or potential tissue damage, or described in terms of such damage.” Chronic pain differs from acute pain, in that it persists continuously or intermittently for longer than three months (2).

In developed countries, chronic pain is a common complaint and constitutes a major public health and socioeconomic problem (3). The Institute of Medicine (IOM) of the National Academies in the United States of America (USA), found that chronic pain is widely undertreated or mistreated, patients are stigmatized and physicians are inadequately educated, which consequently results in a large financial burden on the economy (4). The incidence of chronic pain varies internationally between 12-50% (1, 5-10).

In the second decade of the 21<sup>st</sup> century, there has been a movement in the developed world to make chronic pain a health priority (11). In 2004, World Health Organization (WHO) representatives joined global specialists in chronic pain management at a conference in Geneva to press for urgent action from governments across the world (12). “The Societal Impact of Pain 2011” symposium in the European Parliament in Brussels was the first step for Europe in attempting to address pain as a major health problem. The “Road Map for Action” was the outcome of this symposium and outlines seven key policy dimensions on how governments can address the societal impact of pain. Initial insights from a European and Australian Road Map Monitor 2011 were consequently presented during the 7th Congress of the European Federation of IASP Chapters (EFIC) in Germany. The Road Map Monitor 2011 provides politicians and health care decision makers with a benchmark on national policy in pain care throughout Europe and Australia. (13) In the USA, the call for urgent action by

governments was answered by the IOM committee, who produced a report in July 2011 that addressed pain as a major health issue (4).

South Africa (S.A) is a developing country with limited resources that are directed at catering for a growing population where life threatening conditions like Human Immunodeficiency Virus (HIV)/Acquired Immunodeficiency Syndrome (AIDS), violent crimes, and poverty predominate (14). Statistics show that pain is second only to fever as the most common symptom in ambulatory persons with HIV/AIDS (12). There is a paucity of data on chronic pain in S.A and few (3, 15, 16) have described the prevalence rates in this country. Igumba et al (3) conducted a study within a rural setting in S.A and found that in the rural region of Mtatha in the Eastern Cape, 38.5% of the sampled adults (n=473) reported chronic pain in at least one anatomical site. A multinational study by Tsang et al (15) describes the prevalence in S.A to be 48.3%. However this study had significant limitations that will be probed further on in the discussion. Chronic pain is a worldwide health problem and from these two limited studies, S.A's prevalence rates seem to not vary much from international prevalence rates. Chronic pain is known to be common but the magnitude of the problem is unclear, especially in Africa where research on this topic is lacking. As a result, S.A has not yet identified chronic pain as a health priority and thus not in keeping with international trends.

S.A is an emerging economy and it is crucial that resources are allocated appropriately. Currently, it is difficult to estimate the number of pain clinics/centers/units in S.A, as there is no regulatory authority that is currently responsible for the registration of these entities. There are many practices offering help to chronic pain patients and claiming to specialise in specific pain problems for example migraines and back pain.

Extensive guidelines on record keeping are highlighted by the Health Professions Council of South Africa (HPCSA) (17) . Clinical records are a basic clinical tool that also serves as a medicolegal document. The HPCSA summarises the importance of meticulous record keeping in a statement that holds all health care workers accountable: "Health care practitioners who decide not to follow the guidance in this Booklet (including the Annexure), must be prepared to explain and justify their actions and decisions to patients and their families, their colleagues and, if necessary, to the courts and the HPCSA." (17)

In common with many chronic conditions, there is very little known as to how services are matched to needs. Frohlich & Shipton (14) posed the question in 2007 "Can the development of pain management units be justified in an emerging democracy?" They concluded that the

“need for education in pain management and establishment of adequate acute and chronic pain services cannot be over emphasised and withholding adequate pain control cannot be justified.” (14) S.A currently lacks the epidemiological data to support this issue.

### **1.3 Problem statement**

The Declaration of Montreal (Appendix I) declares that “access to pain management is a fundamental human right” and was supported by summit delegates from 129 countries at the 13<sup>th</sup> World Congress on Pain in Montreal (18, 19). A Human Rights Watch report estimated that 80% of the world’s population had either insufficient access or no access to treatment for moderate to severe pain (20). The Human Rights Watch has called for governments to address this crisis under international human rights law (20).

Comprehensive information is needed on the epidemiology and burden of chronic pain in the population for the development of appropriate health interventions. S.A currently lacks the epidemiological data to support lobbying for chronic pain as a health priority, and auditing the Helen Joseph Hospital Pain Management Unit (HJHPMU) is a step towards addressing the paucity of epidemiological data on chronic pain in S.A. The data obtained will also provide an opportunity to compare the epidemiology of chronic pain in the South African population with international studies, as well as addressing a need at the HJHPMU.

### **1.4 Aim**

The aim of this study was to describe the profile of chronic pain patients at the HJHPMU for 2011 and to determine the adequacy of record keeping.

### **1.5 Objectives**

The primary objectives of this study were to determine the:

- number of pre-existing and new patients consulted in 2011
- demographic profile of patients attending the HJHPMU (age and gender)
- presenting complaint of patients
- diagnosis
- relevant medical history
- relevant surgical history
- type of pain.

The secondary objective of this study was to determine the adequacy of record keeping.

## 1.6 Research assumptions and definitions

The following definitions were used in this study.

**Chronic pain:** pain lasting longer than three months.

**Pain clinic:** where single modalities are employed, or single pain entities are treated e.g. headache clinic, back pain clinic, acupuncture clinic, etc. (21).

**Pain Management Unit:** a group of multidisciplinary health care professionals related to acute and chronic pain. No research component is present (22).

**Pain center:** a group of multidisciplinary health care professionals and basic scientists that includes research, teaching and patient care related to acute and chronic pain. This is the most complex of the pain treatment facilities and ideally would exist as a component of a medical school or teaching hospital (21).

**Helen Joseph Hospital's Pain Management Unit database:** this is a paper-based diary held by the HJHPMU, noting all appointments. No formal electronic database exists.

**Relevant medical history:** chronic medical conditions that could contribute or developed as a consequence of the underlying pathology.

**Relevant surgical history:** patients who had trauma or surgery that contributed to the pain condition.

## 1.7 Demarcation of study field

This study was conducted at the HJHPMU. Helen Joseph Hospital has 512 beds and is affiliated to the University of the Witwatersrand. The HJHPMU is a large multidisciplinary unit, comprising of pain specialists, a social worker, psychologist, group therapy councillor, physiotherapist and occupational therapist. They accept referrals from medical professionals and allied health professionals from other Gauteng hospitals.

## **1.8 Ethical considerations**

Approval to conduct this study was obtained from the Postgraduate Committee (Appendix II) and the Human Research Ethics Committee (Medical) of the University of the Witwatersrand (Appendix III), as well as the Chief Executive Officer of Helen Joseph Hospital (Appendix IV).

The Head of the Helen Joseph Anaesthesiology Department and HJHPMU was approached for written consent to access patients' files and the HJHPMU database (Appendix V). Therefore, no consent was required from patients.

This study did not involve any drug or therapeutic management, and was conducted by adhering to the South African Good Clinical Practice Guideline (23) and the Declaration of Helsinki (24).

## **1.9 Research methodology**

### **1.9.1 Research design**

A retrospective, contextual, descriptive study design was utilised.

### **1.9.2 Study population**

The HJHPMU database and files for patients consulted during the period January 2011 to December 2011.

### **1.9.3 Study sample**

A consecutive sampling method was used and the study sample included the HJHPMU database and all files of adult patients that attended the HJHPMU during the period January 2011 to December 2011.

### **1.9.4 Inclusion and exclusion criteria**

For the purpose of this study, the files of adult patients 18 years and older will be included in the study. Patient files were excluded from the study if insufficient data were found e.g. missing or illegible data.



### **1.9.5 Description of data collection**

An audit was conducted on the demographic profile of chronic pain patients attending the HJHPMU.

Data were entered onto a data capture sheet (Appendix VI) and then onto Microsoft Excel for Mac 2011 spreadsheets. Strict confidentiality was maintained at all times. The following data were collected:

- study number
- number of pre-existing and new patients consulted in 2011
- demographic profile of patients attending the HJHPMU (age and gender)
- presenting complaint of patients
- diagnosis
- relevant medical history
- relevant surgical history
- type of pain.

### **1.9.6 Data Analysis**

Data were analysed using Statistica 10.0, a statistical program, in consultation with a biostatistician. Descriptive statistics were used to analyse the data obtained during the study. Frequencies and percentages have been reported. A Chi-squared test was utilised to analyse any association between gender and type of pain.

## **1.10 Significance of the study**

It has been documented that 80% of the worlds population has either insufficient or no access to treatment of moderate to severe pain (20). Internationally chronic pain is being recognised as a crisis and policies are being implemented to address this issue in developing countries (11).

S.A, a developing country, has very few pain centres, pain management units and pain clinics for a population of over 50 million people (25). Chronic pain epidemiological data is needed to lobby for improved management of chronic pain. There is a paucity of this type of data in S.A. This study may provide epidemiological data from one of the larger pain management units in S.A. It will also provide the HJHPMU with valuable information regarding record keeping proficiency. The results of this study could also assist the management of HJHPMU with future planning and improving the services offered.

### **1.11 Validity and reliability of the study**

Validity and reliability of the study were ensured, in that one researcher collected the data. This ensured standardisation of the data collected. An appropriate study design was chosen. A sample size was determined with the consultation of a biostatistician. A Microsoft Excel spreadsheet was utilised in computing data directly and the data were then rechecked every 20<sup>th</sup> entry. Data were analysed in consultation with a biostatistician.

### **1.13 Project outline**

An outline of this study will now be presented. Chapter one represents an overview of this study. Chapter two includes an in-depth literature review of subject matter pertaining to chronic pain. In chapter three, a comprehensive discussion of the research methodology is offered. Chapter four includes the presentation of the results and the discussion thereof. The final chapter provides the conclusion of the study as well as further recommendations.

### **1.14 Summary**

This chapter provided a brief overview of this study. Topics covered included introduction and background, problem statement, aims and objectives, research assumptions, demarcation of the study field, ethical considerations, research methodology, significance of the study, validity and reliability summary, potential limitations, and project outline. In the following chapter, the literature review is presented.

# Chapter Two - Literature review

## 2.1 Introduction

In this chapter, various concepts regarding chronic pain are reviewed in the literature. An overview on the evolution of pain theories, the postulated mechanisms of chronic pain, a classification of chronic pain which describes nociceptive and neuropathic pain, and the various causes of chronic pain are reviewed. Complex regional pain syndrome (CRPS), myofascial pain syndrome (MPS), chronic lower back pain (CLBP) and failed back surgery syndrome (FBSS) are discussed further as these conditions were found to be the most common conditions encountered by the Universitas Hospital Pain Management Unit (16). Thereafter, chronic pain internationally and within S.A will be reviewed. There is an abundance of literature available on chronic pain internationally, and therefore it has been discussed as the incidence of chronic pain internationally, gender and chronic pain, age and chronic pain, the economic impact of chronic pain and the impact of chronic pain on the individual. The prevalence of chronic pain in S.A, and HIV/AIDS and chronic pain are then reviewed. Pain questionnaires, record keeping and the importance of a clinical audit are thereafter discussed.

## 2.2 The evolution of pain theories

A number of theories have been postulated to describe pain mechanisms. Some of the main pain theories are briefly discussed below.

As early as the 17<sup>th</sup> century, clinicians such as Rene Descartes had been trying to understand the pathophysiology behind pain. In Descartes' manuscript, "Treatise of Man," he describes pain as a perception that exists in the brain and makes the distinction between nociception and the perceptual experience of pain. He also described nerves as hollow tubules that convey both sensory and other information. Since the early work of Descartes, numerous theories have been postulated. (26)

In 1894, Maximilian von Frey posited "The Specificity Theory of Pain" where he suggested that there were subcutaneous receptors for different types of sensory input. (27) These ideas have been emerging over several millennia but were experimentally tested and formally postulated as theory in the 19<sup>th</sup> century. (26)

The Pattern Theory of Pain emerged in 1929 by Nafe. This ignored findings of specialised nerve endings and observations that support the Specificity Theory of Pain. The theory stated that a specific and particular pattern of neural firing resulted in a somesthetic sensation, and that the firing encoded the stimulus type and intensity. (26)

In 1965, Ronald Melzack and Charles Patrick Wall, proposed a theory that would recognise the experimental evidence that supported the Specificity and Pattern Theories in a model that could explain these seemingly opposed findings (26). The Gate-Control Theory claims that a gate-like function of the substantia gelatinosa located in the dorsal horn of the spinal cord, modulates the amount of afferent impulses from the periphery to the transmission cells (T-cells) of the dorsal horn through inhibitory processes at the neuronal level, and thereby controlling the quantity and intensity of the signals to the central nervous system. Furthermore, it was postulated that higher cortical functions contribute to this gating mechanism, which allows for psychological phenomena to directly affect the pain experience. (28) The Gate Control Theory is illustrated in Figure 2.1.

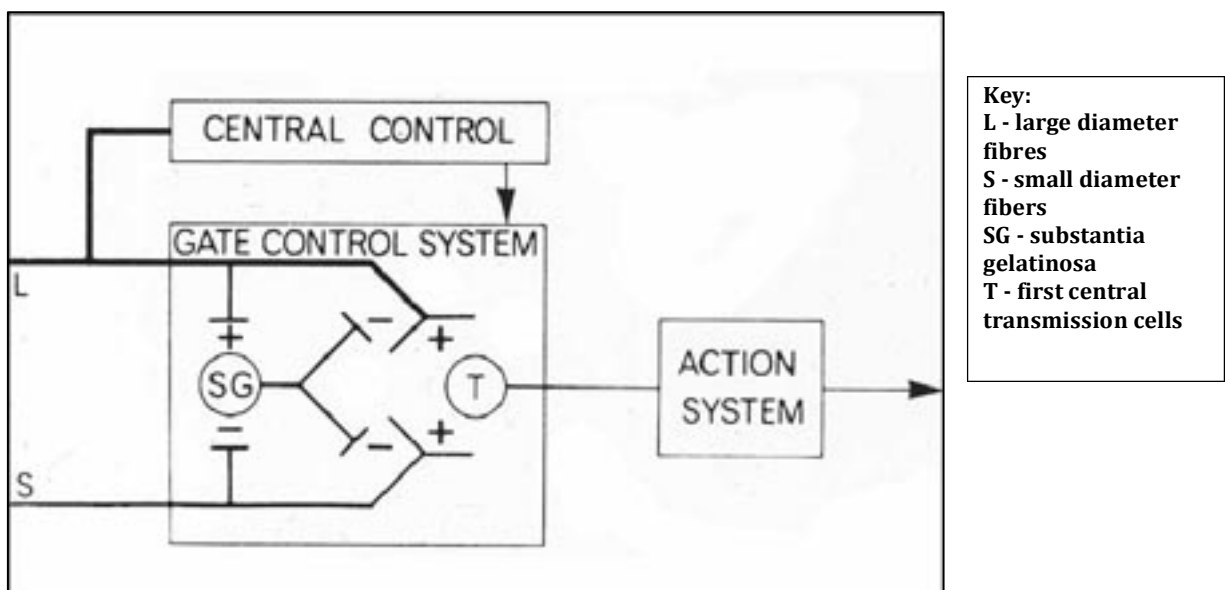

**Figure 2.1** Gate Control Theory (28).

It was thereafter suggested by Gatchel (27), that the psychosocial component in the Gate Control Theory contributes largely in treating patients with pain. Emotions such as helplessness, hopelessness, and anger tend to amplify the intensity of the sensory input while interventions focusing on coping and stress reduction help to “close” the gate. Also behavior

that facilitates keeping this gate “open” includes poor eating habits, smoking, inadequate sleep, and lack of exercise (27).

Melzack in 1999 (29) wrote “as historians of science have pointed out, good theories are instrumental in producing facts that eventually require a new theory to incorporate them.” By observing paraplegics and pondering phantom limb pain, Melzack found that this subset of patients did not fit his Gate Control Theory. The Neuromatrix Model of Pain was subsequently proposed, and incorporates the stress component into the pain equation. Stress functions as a mechanism of adaptation so that the body can respond to challenging or dangerous situations in an attempt to avoid or reduce problematic consequences. Hyperactivity of the hypothalamic pituitary axis can be seen to intensify the pain, and thus individuals experiencing elevated levels of stress may exacerbate the pain experience. This leads to a vicious cycle that continues to threaten homeostasis. Based on the theory provided by Melzack (29), each individual’s neuromatrix, which includes genetics, sensory modalities, and memory, determines the overall interpretation of the experience of pain. (27, 29)

Subsequent to these theories, the Diathesis Stress Model and Biopsychosocial Model for Chronic Pain arose. The Diathesis Stress Model highlights the role of learning in the onset, exacerbation, and maintenance of pain in patients with chronic pain (30). In this model, Turk (30) emphasises the interaction of predisposing factors following trauma, which results in a cascade that maintains disability.

The Biopsychosocial Model, links the biological, psychological, and environmental factors to explain pain phenomena. This model was first introduced in medicine by Engel (31) when he highlighted the fact that as a medical illness became more chronic in nature, the psychosocial “layers” such as illness behavior and the sick role, emerge. Loeser applied Engel’s model to chronic pain, and in his interpretation of the Biopsychosocial Model, the physical origin of pain is at the core and is surrounded by successive layers of “pain experience” and “suffering,” ending at the most derived level “pain behavior” (32). This approach to pain management, allows the physician to address all contributing causes of the pain, and can prevent the pain from becoming unnecessarily disabling (30). The following illustrations are schematic representations by Gatchel et al (27), of the model posited by Engel (Figure 2.2) and Loeser (Figure 2.3).

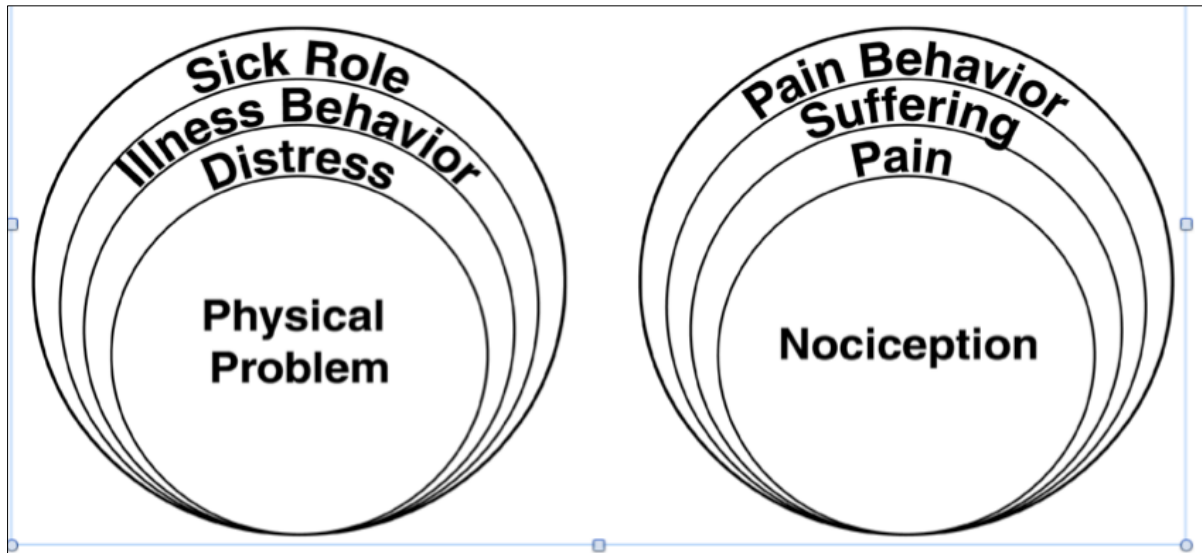

**Figure 2.2** Engel's Model of Illness (27).

**Figure 2.3** Loeser's Model of Pain (27).

### 2.3 Mechanisms of chronic pain

Why pain persists beyond the acute state is often difficult to identify, and in many cases no causative factor can be identified (1). Chronic pain is sometimes in the absence of tissue damage, not triggered in the periphery and often appears long after the noxious stimulus has stopped exerting its effects (33).

The transmission of a painful signal to the spinal cord is only possible if a noxious stimulus causes transduction and activation of a nociceptor. Peripheral sensitisation is the process through which transmission of a painful signal reaches the spinal cord out of proportion to, or in the absence of, a noxious stimulus. In central sensitisation, there is an imbalance at the dorsal horn in the spinal cord between excitatory and inhibitory ascending and descending pathways, tipped in the direction of excitation. (34)

The persistence of pain beyond the acute stage may be explained by central sensitisation, whereby previously non-noxious activities or stimuli come to aggravate pain and other associated symptoms (1). Figure 2.4, is adapted from Meyer et al (34) and illustrates the pathophysiology of chronic pain.

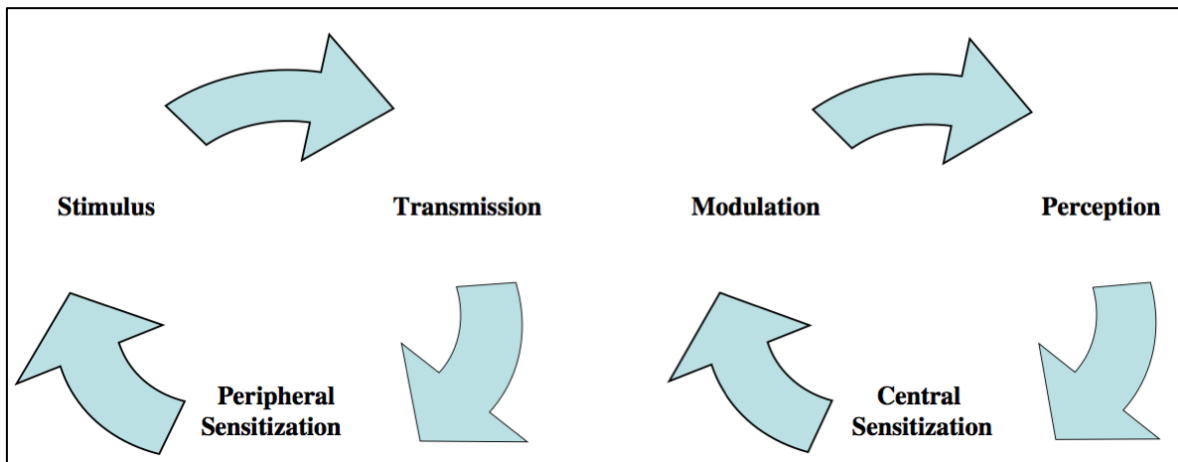

**Figure 2.4** The pathophysiology of chronic pain (34).

Major advances have occurred in the 21<sup>st</sup> century that have identified transduction proteins in nociceptors, cortical imaging studies which reveal how pain is experienced on a cognitive level and genetic factors that are important in the large inter-individual variations in pain response (35, 36). Genetic factors can account for the large inter-individual variations in pain response in cause-specific pain conditions and may help to explain why some individuals progress to persistent pain. Tegeder et al (35) found that in humans, a haplotype of the GTP Cyclohydrolase 1 gene was significantly associated with less pain following discectomy for persistent radicular lower back pain (LBP). Healthy individuals homozygous for this haplotype exhibited reduced experimental pain sensitivity. (35)

The discovery of the mechanisms of pain is still in evolution, and although early work on pain can be traced to the 17<sup>th</sup> century, the worldwide movement to prioritise chronic pain as a disease entity will support further research in this field.

## **2.4 Classification of chronic pain**

Chronic pain can be classified in many ways. Some sources classify chronic pain into nociceptive and neuropathic pain, whilst other sources classify chronic pain as chronic non-cancer pain and chronic cancer pain. Nociceptive and neuropathic pain will be discussed in further detail as it is the most current approach to classifying pain.

### **2.4.1 Nociceptive pain**

Nociceptive pain is defined as a noxious perception resulting from cellular damage and can

follow surgery, trauma or disease related injuries. It is also known as inflammatory pain because inflammation and inflammatory mediators play roles in its initiation and development. The intensity of nociceptive pain is generally proportional to the magnitude of tissue damage and the release of inflammatory mediators. (37, 38) Pain is an appropriate physiological response when a stimulus is applied to a receptor. The stimuli may be thermal, mechanical or chemical and no damage occurs to the conduction pathway of nociceptive pain impulses. (38)

Continuing nociception occurs in some patients with chronic pain. An example is severe osteoarthritis of the hip joint, where hip joint replacement is potentially curative treatment, if indicated and tolerated by the patient. When the nociceptive source, in this case the damaged hip joint, is replaced the central nervous system sensitisation subsides. In about 10% of patients this does not occur and chronic pain continues after surgery. (39)

#### **2.4.2 Neuropathic pain**

The IASP defines neuropathic pain as pain that is initiated or caused by a pathologic lesion or dysfunction in peripheral nerves and the central nervous system (40). In neuropathic pain there is definite damage to the pathway conducting impulses. Examples of neuropathic pain include post-herpetic neuralgia, CRPS and phantom limb pain (38). Four broad classes of diseases are recognised based on etiology and anatomy, however there is no universally accepted classification for neuropathic pain types. These are demonstrated in Table 2.1 which is adapted from the most recent clinical practice guidelines for management of neuropathic pain for the South African population. (41)



<b>Focal or multifocal lesions of the peripheral nervous</b>	<b>Generalised lesions of the peripheral nervous system (polyneuropathies)</b>	<b>Lesions of the CNS</b>	<b>Complex neuropathic disorders</b>
<b>Common/important</b> Post-traumatic neuralgia Phantom limb and stump pain Post-herpetic neuralgia	Diabetes mellitus (leading to diabetic peripheral neuropathy) Alcohol HIV (leading to HIV associated sensory neuropathy) Antiretroviral agents Chemotherapy	Spinal cord injury Stroke	CRPS types I (controversial) and II
<b>Others/miscellaneous</b> Diabetic proximal mononeuropathy Entrapment syndromes Ischaemic neuropathy	Heavy metals, e.g. thallium, arsenic Drugs, e.g. metronidazole, isoniazid, vinca alkaloids Metabolic/genetic, e.g. amyloid, uraemia Nutritional, e.g. vitamin B deficiencies	Multiple sclerosis Syringomyelia Spinal infarction	

**Table 2.1** Etiology based classifications of painful peripheral neuropathies (41).

Chetty et al (41) state that neuropathic pain is widely underdiagnosed in S.A, and although patients may be diagnosed and treated according to evidence based guidelines, not all patients may achieve a satisfactory response.

## 2.5 Causes of chronic pain

Some of the most common chronic pain conditions internationally and locally include chronic low back pain, headache, myofascial pain syndrome, fibromyalgia, peripheral neuropathy, phantom limb pain, CRPS, arthritis, cancer, post-herpetic neuralgia, and chronic post-surgical pain (1, 16). In a study at Universitas Hospital Pain Management Unit, S.A, the most common reasons for visiting this unit is summarised in Table 2.2 (16). Of note is that, diagnoses with a frequency of four individuals or less (with the exception of post-operative pain) were grouped under the diagnoses of 'other' and accounted for the fourth highest frequency of diagnosis.

<b>Primary diagnosis</b>	<b>Frequency (n)</b>	<b>Percentage (%)</b>
Chronic lower back pain	136	49,28
Myofascial Pain Syndrome	64	23,19
Neuropathic pain	16	5,80
Other	15	5,43
Headache	12	4,35
Post-herpetic neuralgia	9	3,26
Complex Regional Pain Syndrome	7	2,54
Arthritic pain	6	2,17
Joint pain	5	1,81
Post operative pain	4	1,45
Injury related pain	2	0,72

**Table 2.2** Primary diagnosis of patients attending the Universitas Hospital Pain Management Unit in the Free State, S.A (16).

CRPS, myofascial pain syndrome, CLBP and failed back syndrome will be discussed briefly as they have been found to be high in occurrence in a pain management unit in S.A (16).

### **2.5.1 Complex regional pain syndrome**

In 1865, the neurologist Silas Weir Mitchell reported that soldiers complained of strong burning pain, hyperesthesia, edema, and reduction of motor function of the limb following injuries of the upper or lower extremity. Mitchell named these disturbances “causalgia.” (42) Some of the clearest descriptions of causalgia come from Mitchell’s observations during the American Civil War. The low velocity, high mass missiles used during this war were effective in producing autonomic neuropathy with autonomic dysregulation (43). In the years to follow, this condition was given many names from algodystrophy, reflex sympathetic dystrophy, Morbus Sudeck, and to what is now referred to as CRPS. Two types are recognised, CRPS type I is without nerve injury and CRPS type II is associated with major nerve injury. (42)

In 90–95% of patients there is a recent traumatic event in the clinical history. The reason why only some patients develop CRPS is still unclear. Inflammation has been used to explain

the pathophysiology behind CRPS. This hypothesis is supported by the fact that the classic inflammatory signs and symptoms are prominent, especially in the early stages of the disease, and that these symptoms are positively influenced by the use of corticosteroids. (42)

The prognosis for CRPS is unfavorable, and only 25–30% of all patients fully recover, according to the degree of severity and their comorbidity. CRPS is a purely clinical diagnosis and there is no laboratory test to support the diagnosis. (42) The current clinical diagnostic criteria, according to Harden and Bruehl (44), is listed in Table 2.3.

1	<b>Persistent pain, which is disproportionate to any known inciting event</b>
2	<b>The patient must report at least one symptom in three of the following categories:</b>
	Sensory: Reports of hyperesthesia and/or allodynia
	Vasomotor: Reports of temperature asymmetry and/or skin color changes and/or skin color asymmetry
	Sudomotor/edema: Reports of edema and/or sweating changes and/or sweating asymmetry
	Motor/trophic: Reports of decreased range of motion and/or motor dysfunction (weakness, tremor, dystonia) and/or trophic changes (hair, nails, skin)
3	<b>The patient must display at least one sign in two or more of the following categories during the current physical examination:</b>
	Sensory: Evidence of hyperesthesia and/or allodynia
	Vasomotor: Evidence of temperature asymmetry and/or skin color changes and/or skin color asymmetry
	Sudomotor/edema: Evidence of edema and/or sweating changes and/or sweating asymmetry
	Motor/trophic: Evidence of decreased range of motion and/or motor dysfunction (weakness, tremor, dystonia) and/or trophic changes (hair, nails, skin)
4	<b>There is no other diagnosis that would otherwise account for the signs and symptoms and the degree of pain and dysfunction.</b>

**Table 2.3** Budapest clinical diagnostic criteria for CRPS (44).

Following a fracture or nerve injury, approximately 1% of patients develop CRPS. The upper extremity is more often affected, and a fracture is the most common trigger (60%). The

incidence in the Netherlands has been estimated to be 26/100,000 persons per year, with females being affected at least three times more often than males. In another population-based study from the United States, the incidence was estimated at 5.5/100,000 persons per year. (42) However, in recent years, there has been a radical increase in the reporting of the syndrome in the USA due to personal injury lawsuits (44).

### **2.5.2 Myofascial pain syndrome**

Myofascial pain syndrome (MPS) is defined in an article by Borg-Stein and Simons (45) as “pain that originates from myofascial trigger points (MTrPs) in the skeletal muscle, either alone or in combination with other pain generators.” MTrPs are discrete areas of focal tenderness within a muscle that are characterised by hypersensitive palpable taut bands of muscle that are painful to palpation. Manual pressure over these points reproduces the patient’s pain and refers the pain in a characteristic pattern. (45)

The lack of universally accepted diagnostic criteria for MPS has resulted in a wide range of epidemiological data. The prevalence varies from 21-90% of patients depending on the treatment center. It affects both genders equally. (46)

Criteria that are available for diagnosis of MPS are purely clinical (47). Symptoms of myofascial pain may begin after a discrete trauma or injury or may be of insidious onset. Patients note localised or regional deep aching sensations, which can vary in intensity. The MTrPs of each muscle have their own characteristic pain pattern; therefore, the distribution of pain can help identify which muscles may contain the responsible MTrP. Associated autonomic dysfunction may occur, including abnormal sweating, lacrimation, dermal flushing, and vasomotor and temperature changes. Cervical myofascial pain may be associated with symptoms that include imbalance, dizziness, and tinnitus. Functional complaints include decreased work tolerance, impaired muscle coordination, stiff joints, fatigue, and weakness. Other associated neurologic symptoms include paresthesias, numbness, blurred vision, twitches, and trembling. Later stages can be compounded by sleep disturbance, mood changes, and stress. (45)

### **2.5.3 Chronic lower back pain**

LBP has been described as pain that is localised to the lumbar area between the inferior ribcage and the waistline, and may include sciatica, with pain radiating down the posterior-

lateral thigh distal to the knee (48).

The origin of back pain remains unclear in more than 80% of patients (49). The lifetime prevalence of LBP ranges between 60% and 85%. Most adults will experience an episode of LBP at least once during their lifetime (50). Blythe et al (51) found that 45% of patients with chronic pain, experienced back pain.

Table 2.4 illustrates the causes of lower back pain (48).

Category of pain	Percentage of lower back patients in patients	Differential Diagnosis
Nonspecific	70	Lumbar Strain/Sprain
Visceral/ referred Non-malignant	2	Aortic aneurysm; Pelvic organ diseases (prostatitis, endometriosis, pelvic inflammatory disease) Gastrointestinal disease (pancreatitis, cholecystitis, penetrating peptic ulcer) Renal disease (nephrolithiasis, pyelonephritis)
Non-mechanical	1	Neoplasia (multiple myeloma, metastatic carcinoma, lymphoma, leukemia, spinal cord tumors, retroperitoneal tumors, primary vertebral tumors) Inflammatory arthritis, often HLA-B27-positive (ankylosing spondylitis, psoriatic spondylitis, Reiter syndrome, inflammatory bowel disease) Infection (osteomyelitis, septic discitis, paraspinous abscess, epidural abscess, perinephric abscess, shingles) Scheuermann disease (osteochondrosis) Paget disease of bone

**Table 2.4** Differential diagnosis of lower back pain and the percentage of adult lower back pain patients in primary care (48).

### 2.5.4 Failed back surgery syndrome

FBSS is defined as persistent or recurrent pain, mainly in the lower back and/or legs, even after previous anatomically successful spinal surgery (52). The number of spinal surgeries performed in the USA is on the increase (53). The U.S Center for Disease Control and Prevention, reported that there were 317,000 lumbar surgeries performed in the USA in 1997, and the cost of surgery itself exceeded 4.8 billion US dollars per year (54). A study performed within the state of Maine in the USA found that the best results from spine surgery occurred in the areas with the lowest surgical rates while the worst outcomes occurred in areas with the highest surgical rates. The authors have suggested that this observation may be due to differences in selection criteria for surgical patients and physicians' recommendations for operations between the different areas. (55) The number of patients suffering from FBSS has increased with increasing rates of spinal surgery, despite advances in technology and surgical techniques (56). However, failure rates differ between the different surgical procedures, with procedures such as lumbar discectomy demonstrating high success rates. Table 2.5 describes the etiology of FBSS. (53)

<b>Preoperative factors</b>
• Patient
• Psychological: anxiety, depression, poor coping strategies,
• Social: litigation, worker compensation
• Surgical
• Revision surgery
• Candidate selection
• Surgery selection
<b>Intraoperative factors</b>
• Poor technique
• Incorrect level of surgery
• Inability to achieve the aim of surgery
<b>Postoperative factors</b>
• Epidural fibrosis
• Surgical complications
• New spinal instability
• Myofascial pain development

**Table 2.5** Etiology of Failed Back Surgery Syndrome (53).

Russell et al (57) concluded in a case discussion on FBSS that the availability of multidisciplinary treatment regimes for this condition makes satisfactory outcomes possible (57).

## **2.6 Chronic pain internationally**

### **2.6.1 Prevalence of chronic pain**

Epidemiological studies conducted in different countries globally, report prevalence rates for chronic pain ranging from 12-80% (58). This wide range can be attributed to the heterogeneity in the populations studied, the occurrence of undetected comorbidity, the application of different definitions of chronic pain and different approaches to data collection (8). Table 2.6 summarises the prevalence rates reported internationally. Three landmark studies will be described in further detail.

The New South Wales (NSW) Health Survey of 1997 and the Northern Sydney Area (NSA) Pain Study of 1998 are two of the most representative studies of chronic pain in the general Australian adult population. A pertinent factor is that these studies both used the IASP definition for chronic pain when conducting computer assisted telephonic interviews. (1) The NSW Health Survey showed a prevalence rate of 20% in females and 17,1% in males (51). This is the more representative of the two surveys as it includes non-English speakers and individuals from rural areas. Australia projects the prevalence of chronic pain to increase from 3,2 million Australians in 2007 to 5 million by 2050, as the population advances in age (1).

Tsang et al (15) conducted a landmark study, which included 17 countries. These were the Americas (Columbia, Mexico, United States), Europe (Belgium, France, Germany, Italy, Netherlands, Spain, Ukraine), the Middle East (Israel, Lebanon), Africa (Nigeria, S.A) and Australasia (Japan, Peoples Republic of China, New Zealand). Face-to-face interviews were conducted by trained lay interviewers and a sample size of 85 052 was achieved with a response rate of 71%. Developed countries had a chronic pain prevalence rate of 37.3% and developing countries had a prevalence rate of 41.1%. The Human Development Index was used to categorise countries into developed (Belgium, France, Germany, Israel, Italy, Japan, Netherlands, New Zealand, Spain and the United States) and developing (China, Columbia, Lebanon, Mexico, Nigeria, S.A and Ukraine). The limitations of this study however are of note, as the IASP definition for chronic pain was not used. Respondents were asked to subjectively define chronicity in response to interview questions and their responses are likely to reflect a



broad spectrum of pain severity and duration. Table 2.7 provides more detail into the prevalence rates of each country as per Tsang et al (15).

<b>Study</b>	<b>Country</b>	<b>Prevalence (%)</b>	<b>Definition of pain used</b>
Blythe et al (51) 2001	Australia	22,1	Pain experienced everyday for 3 months in the 6 months prior to the interview
Wong et al (59) 2011	China	34,9	Pain lasting more than 3 months
Rustoen et al (60) 2004	Norway	24,4	Pain for more than 3 months duration
Breivik et al (61) 2006	15 European countries and Israel	12-30	Pain lasting for more than 6 months, having pain during the last month, several times during the last week and last experienced pain having an intensity of 5 or more on a Numeric Rating Scale of 1-10
Yu et al (62) 2006	Taiwan	42	Brief Pain Inventory was used, which asks subjects to rate their average pain intensity and worst pain intensity on a numeric scale
Nakamura et al (63) 2011	Japan	15,4	A symptom present within the past month that has continued for at least 6months and corresponds to a Visual Analogue Scale (VAS) of at least 5
Sjogren et al (5) 2009	Denmark	20,2	
Tsang et al (15) 2008	7 developing countries 10 developed countries	37,3 (developed countries) 41,1 (developing countries)	In face-to-face interviews by trained lay interviewers, respondents were asked if they had ever had 'arthritis or rheumatism,' chronic back or neck pain, frequent or severe headache and other chronic pain in their lifetime and if this had been present in the prior 12 months.
Jakobsson (64) 2010	Sweden	46	Chronic pain – at least 3 months
Gallup Healthways Well-Being Index (65) 2012	USA	47	Neck or back condition, a knee/leg condition or another condition that caused recurring pain in the last 12 months
Smith (66) 2001	Scotland	50,4	Pain of at least 3months

**Table 2.6** Summary of international prevalence rates for chronic pain.

<b>Country</b>	<b>Crude prevalence of any chronic pain conditions (%)</b>
<b>Developing Countries</b>	
Ukraine	60,4
South Africa	48,3
China (Beijing)	37,0
Nigeria	30,4
China (Shanghai)	34,5
Lebanon	26,4
Columbia	27,3
Mexico	24,1
<b>Developed Countries</b>	
France	49,6
United States	43,9
Italy	45,5
Belgium	40,5
New Zealand	39,1
Spain	34,9
Israel	33,5
Netherlands	33,3
Germany	32,4
Japan	28,1

**Table 2.7** Summary of chronic pain prevalence rates as per Tsang et al (15).

In 2003, Breivik et al (61) conducted computer assisted telephonic surveys in 15 European countries and Israel. Of the respondents, 19% had moderate or severe pain of at least six months duration, experienced pain in the last month, or had pain at least twice a week. There were 46 394 respondents, however there was a 46% overall refusal to answer the questionnaire, which varied between countries. (61)

Studies on chronic pain are poorly standardised, and with the wide range of variables such as different age populations as well as gender influences, comparison of data pertaining to different populations and countries is hampered.

### **2.6.2 Gender and chronic pain**

The reason for gender related differences in pain prevalence are not completely understood, however the Biopsychosocial Model can be applied to account for these differences. Chronic pain may vary according to gender because males and females experience different diseases, each producing a distinct type of pain. (60) Studies in Norway, Australia and Europe show that females have a higher prevalence of pain when compared to males (7, 51, 60, 61).

However, studies in Finland and England have found chronic pain to be as common in men as in women (7, 67).

According to Berkley (68), females have a lower pain threshold, greater ability to discriminate painful sensations, higher pain ratings, and a lower tolerance for pain (68). Functional imaging studies have been utilised in examining brain responses to somatic noxious stimulation. These studies have provided mixed results. Table 2.8 is adapted from the IASP, and provides a concise view of the results of some of these studies. (69)

Study	Noxious stimulation	Amygdala	Thalamus	Insula	ACC	Primary sensory	Secondary sensory	Prefrontal Cortex
Paulson et al (70) 1998	Contact heat		F ↑	F ↑				F ↑ M ↑
Derbyshire et al (71) 2002	Laser			M ↑	F ↑		M ↑	M ↑
Moulton et al (72) 2006	Contact heat				M ↑	M ↑ F ↓		M ↑ F ↓
Zubieta et al (73) 2002	Opioid binding	M ↑	M ↑					
Smith et al (74) 2006	Opioid binding	M ↑	M ↑					

<b>Key:</b> <b>M - male</b> <b>F - females</b> <b>↑ - increase</b> <b>↓ - decrease</b>
--

**Table 2.8** Summary of functional imaging studies in examining brain responses to somatic noxious stimulation (69).

It has been found that women have increased mu-opioid binding during pain in the anterior thalamus, ventral basal ganglia, and amygdala when compared to men (73). Smith et al (74) found that this occurs during the low-estrogen period of women’s menstrual cycle.

Although biological differences offer plausible reasons to the gender related pain experiences, the Biopsychosocial Model should be applied as the psychological and social influence on gender associated chronic pain is pertinent.

### 2.6.3 Age and chronic pain

Age is associated with an increase in painful pathology. A common concern amongst developed countries is an ageing population. In Australia for example, it is estimated that over the next 20 years the number of people aged over 65 years will increase to more than one in five, surpassing the number of children under 15 years of age. (39) Chronic pain is expected to rise in developed countries, as the population of the aged increases, and will thus impact on the growing prevalence and socioeconomic burden of chronic pain. International studies have shown varying patterns for the age distribution of chronic pain sufferers and reasons for this could be the use of differing age strata, different definitions of chronic pain applied and possibly the underlying populations structures. Table 2.9 summarises the age of peak prevalence for chronic pain in a few countries.

Country	Age of peak prevalence (years)	Prevalence (%)
Sweden (64) 2010	60-74 and >90	>50
China (59) 2011	40-49	41,7
Australia (51) 2001	65-69	27
Japan(63) 2011	40-49	18,6
Canada (75) 2002	>50	39

**Table 2.9** Summary of age of peak prevalence for chronic pain.

Blythe et al (51) showed in the NSW Health survey that the prevalence of chronic pain peaked at 27.0% in the 65 - 69 year age group. Gender differences in age group prevalence were found. Men were found to have the highest prevalence of chronic pain between the ages of 55 - 69 years. For females, prevalence peaked in the oldest age group of 80 - 84 years. However, it should be noted that in this study the sample numbers in extreme age groups contained small numbers of respondents, and respondents had to be 16 years and older (51).

There is a relative paucity of epidemiological data on chronic pain in children when compared to adults. Perquin et al (76) reported a 25% prevalence rate of chronic pain in Dutch children and adolescents and noted a marked increase in chronic pain prevalence in girls aged 12 - 14 years, which was postulated to be attributed to the onset of menstruation. A subgroup of children and adolescents with chronic pain will have poor school attendance, reduced participation in athletic and social activities, and sleep disturbances (77). Children

with chronic pain may continue into adulthood with chronic pain, other physical complaints and psychiatric symptoms, increasing the socioeconomic burden on society (78).

The burden of chronic pain is not restricted to a particular age group within society, yet most studies in the literature place emphasis on the adult population. However, children and adolescents form a considerable part of the demographic profile of chronic pain sufferers and by instituting interventions in this age group, some socioeconomic consequences may be circumvented.

#### **2.6.4 Economic impact of chronic pain**

The IOM estimates the cost of chronic pain to be at least 560 - 635 billion US dollars annually (79). This is likely to be an underestimation, as indirect costs, as well as costs of pain among institutionalised and non-civilian (e.g. military) populations were not included (80).

The mean cost per chronic non-cancer pain patient in Ireland was estimated at 5 665 Euro per year across all grades of chronic pain. The grade of chronic pain was an important determinant of costs, with mean costs for Grade 4 pain more than four times greater than Grade 1 pain. (81) Table 2.10 illustrates the mean cost of each expense related to the treatment of chronic pain.

	<b>Mean cost per patient (Euro)</b>	<b>Total (%)</b>
<b>Direct Costs</b>		
Inpatient admission	1,216	21.5
Outpatient costs	507	9.0
Prescription	224	4.0
Psychologist	193	3.4
General Practitioner	185	3.3
Accident and Emergency	115	2.0
Physiotherapy	114	2.0
Non-prescription	85	1.5
Chiropractor	76	1.3
Other direct costs	241	4.3
<b>Total direct costs</b>	<b>2,959</b>	<b>52.2</b>
<b>Indirect costs</b>		
Annual benefits	1,647	29.1
Loss of wages	372.74	6.6
Changes to home and or equipment	345.30	6.1
Hiring extra help	93.89	1.7
Childcare/cleaning	85.65	1.5
Loss of wages to relatives	77.42	1.4
Transport	14.00	0.3
Other	70.23	1,24
<b>Total indirect costs</b>	<b>2,706</b>	<b>47,8</b>
<b>Total costs</b>	<b>5,665</b>	<b>100</b>

**Table 2.10** Mean cost of each expense related to the treatment of chronic pain (81).



In Australia, the total financial cost of chronic pain was estimated to be 34.3 billion Australian dollars in 2007, including productivity losses, health system costs, caregiver costs and other indirect costs. The High Price of Pain report in 2007 estimated that applying evidence based treatments for chronic pain could halve the cost of chronic pain to the Australian economy, which equates to a saving of 17 billion Australian dollars per annum. (1) Michael Cousins, the Chairperson of the Steering Committee at the National Pain Summit, equates this to be “one of the most major advances in health care since the introduction of antibiotics.” (39)

### 2.6.5 Impact of chronic pain on the individual

In a pan-European study, Breivik et al (61) found that 31% of respondents with pain were employed full time, 13% were employed part time, 24% were retired and 22% were unemployed. The mean time lost from work due to pain was 7.8 days in the last six months (61). These figures have severe implications not only for the pain sufferer but for the family as well.

The impact of chronic pain on relationships, sexual relations and performing normal daily tasks has been well documented. In the above mentioned study, interviewers read out a list of activities and asked respondents to rate their ability to do the activities on a 3-point scale, i.e., just as able, less able, or no longer able to take part (61). The figure below by Breivik et al (61), summarises the effects of chronic pain on daily activities in 16 countries in Europe.

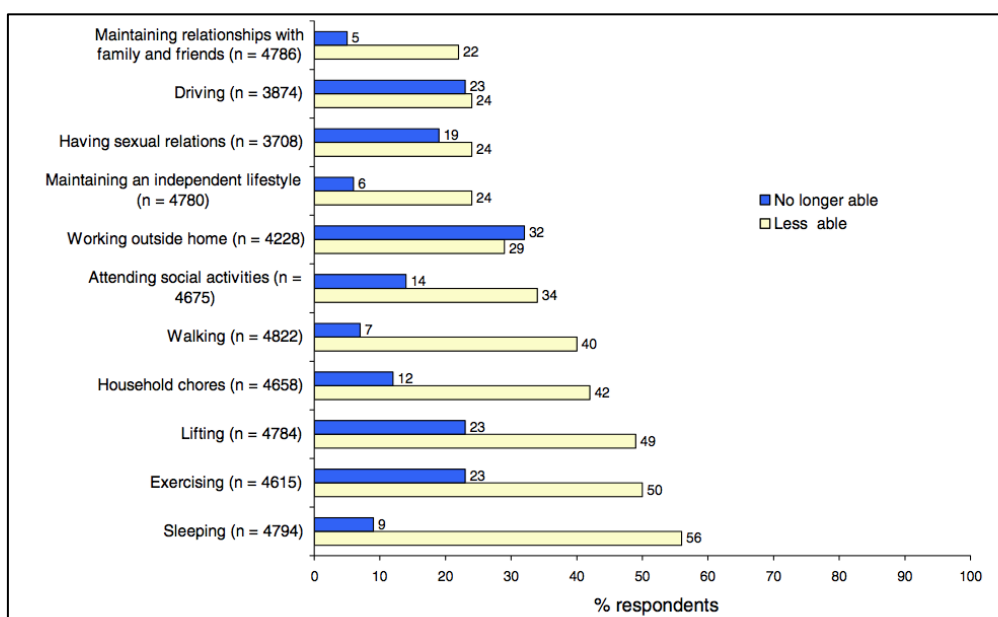

**Figure 2.5** Effect of chronic pain on daily activities (61).

An individual's inability to function, as illustrated in figure 2.5 has consequences for the pain sufferer, family and friends, and the state.

## **2.7 Chronic pain in South Africa**

### **2.7.1 Prevalence of chronic pain in South Africa**

Little is known about the epidemiology of pain in S.A. Four studies were found in the literature that researched chronic pain in this population, two of which were conducted in pain management units. (3, 15, 16, 82) These studies have significant limitations that will be reviewed further.

In 2011, Igumba et al (3) described the epidemiology of chronic pain in the rural region of Ngwalizwe, Mthatha, which has a population of 70 000 people. The median income of respondents was R1250 per month with 83,5% of respondents earning less than R3000 per month, placing them in the lower socioeconomic bracket. Over 37% of respondents were unemployed, while an additional 8,9% stated that they were "looking for a job." (3) International studies have shown chronic pain to be more prevalent in lower socioeconomic classes and respondents that were unemployed reported more severe grades of pain (51). The prevalence of chronic pain was found to be 32,1%, with the majority of chronic pain sufferers being female (58,6%). There was a marked increase in the prevalence of chronic pain after the age of 55 years and in the age group 25 years or less. When describing the study population, Igumba et al (3) defines the "adult population" as "individuals aged 18 years or older." The study further describes the chronic diseases reported by respondents, however it is unclear if these respondents reported chronic pain, and thus no association between these chronic diseases and chronic pain can be concluded. Also, this population is noted to "prefer traditional healers to doctors" and thus the prevalence of chronic diseases could have been underestimated. This study is the first on chronic pain in S.A, however the numerous limitations must be kept in mind. The prevalence rate of this small part of the Eastern Cape gives insight into one particular socioeconomic group in S.A. (3)

Tsang et al (15) conducted a multi-national study, described earlier in the review from an international perspective. The results from this study must be viewed while being cognisant of the limitations. The limitations in general were mentioned when discussing the international prevalence rates found by Tsang et al (15), however, very specific limitations apply when looking at the South African population. No note is made of how the South African population was sampled and thus no conclusions can be drawn about how

representative the sample was of the population. Trained lay people were used to interview respondents, and no mention is made of how many languages were offered to respondents in this interview process. S.A is a country with eleven official languages, with great diversity in socioeconomic status and education level. As with the study conducted by Igumba et al (3), where only a small fragment of South African people were represented, a conclusion about how representative this population was cannot be made.

Walker et al (16) conducted a study at the Universitas Hospital in Bloemfontein in 2005 in an attempt to start establishing locally relevant chronic pain profiles. Some of these results were reviewed during the discussion on causes of pain. Participants in this study were required to complete a questionnaire consisting of biographical questions. Three hundred and twenty five of the questionnaires were used for data analysis. Diagnostic information was collected from patient files. However, diagnoses were available for only 276 of the participants reflecting possible flaws with record keeping or data collection. Walker et al (16) found that 69.23% of the participants were female and 80,31% of the individuals receiving treatment for chronic pain were 40 years of age or older, with a total range of 20 to 84 years. Patients were also asked to provide information regarding the origin of their pain. The most common origin of pain was perceived to be spontaneous (36,31%), where these patients were thought to mostly view their pain as a symptom of another medical condition or as a pain syndrome in itself. Injury-related pain accounted for a further 33,23% of the cases reported, with inexplicable or non-specific origins being the third most frequent (21,23%), and post-operative pain (9,23%) accounted for the remainder. Some of the limitations of the study were discussed by the author, however of note is that 15% of patient files did not have a diagnoses available. (16)

An unpublished study was conducted at the HJHPMU during 1<sup>st</sup> January 2005 to the 1<sup>st</sup> of December 2008. The results of this study however, were presented as a poster at the 2009 World Interventional Pain Congress in New York. A retrospective study with data collection from patients' files was conducted. The aims of this study included evaluating their demographic details, clinical diagnosis, referral base, trends in VAS scores, evaluate compliance and future management plans. The most relevant details of this study are that 59% of the patients were female and the majority of the patients were between the ages of 60-69 years of age. However, as this study was only presented as a poster, limited information is available as to the details of the methodology and results. (82)

### **2.7.2 HIV/AIDS and chronic pain**

Ten years ago, AIDS was a fatal illness with a poor prognosis. Today, antiretroviral therapy has transformed HIV disease into a chronic illness, with pain being second only to fever as the most common symptom amongst ambulatory persons with HIV/AIDS (12). In 2009, the Jointed United Nations Programme on HIV/AIDS (UNAIDS) estimated that the HIV prevalence in S.A was 17,8% (83).

Estimates of pain among patients infected with HIV/AIDS have been reported to range from 30% to over 90% (84). The prevalence varies depending on the stage of disease, care setting, and study methodology. Marcus et al (85) suggest that 25 - 30% of outpatient and/or ambulatory patients with early HIV disease experience clinically significant pain. (85)

In a survey of ambulatory HIV/AIDS patients, respondents described an average of two to three concurrent pains at a time, which is comparable to descriptions of pain among patients with cancer. Most pain in patients with HIV/AIDS can be attributed to the direct effects of HIV/AIDS on the central or peripheral nervous system, opportunistic infections, HIV/AIDS associated cancers, or medications. As many as 85% of patients with HIV/AIDS-related pain may be undertreated, far exceeding the under-medication of pain in cancer patients. (85)

## **2.8 Pain questionnaires**

Valid and reliable assessment of pain is crucial for clinical trials and effective pain management. Several instruments have been developed for assessing the qualitative aspects of different types and subtypes of chronic pain and its impact on function. The Brief Pain Inventory (BPI) and the McGill Pain Questionnaire (MPQ) are two of the most commonly used questionnaires and will briefly be discussed. They have been validated in various languages and countries globally.

The BPI assesses pain severity and the degree of interference with function. It can be self-administered, given in a clinical interview, or administered telephonically. The BPI asks the patient to rate their present pain intensity, "pain now", and pain "at its worst", "least", and "average" over the last 24 hours to account for variations in pain intensity during the day. Location of pain on a body chart and characteristics of the pain are documented. The BPI also asks the patient to rate how much pain interferes with seven aspects of life: general activity, walking, normal work, relations with other people, mood, sleep, and enjoyment of life. Relief from the current treatment regime is also rated. (86)

The MPQ and the short-form MPQ (SF-MPQ) evaluates sensory, affective, evaluative, and temporal aspects of the patient's pain condition. The SF-MPQ consists of 11 sensory (e.g. sharp, shooting, etc.) and four affective (e.g. sickening, fearful) verbal descriptors. The patient is asked to rate the intensity of each descriptor on a scale from 0 to 3. Three pain scores are calculated: the sensory, the affective, and the total pain index. Patients also rate their present pain intensity on a 0 – 5 scale and a Visual Analogue Scale. (87) The MPQ was developed for a first world healthcare setting, where patients take the questionnaire home and bring it back to the clinic completed. Due to time constraints and language barriers, the HJHPMU uses a modification of the MPQ, adapted by Frohlich (Appendix VII). This modification requires the pain specialist to ask the patient questions and for the pain specialist to fill these in. The specialist then examines the patient, and a diagnosis or differential diagnosis is assimilated.

A significant limitation in assessing pain is in patients with whom staff members are unable to communicate, in patients with cognitive impairment and dementia. (88) This poses a challenge to South African pain specialists, as there are eleven official languages in S.A. Subsequent to this research being done, Shaikh et al (89) published the first study demonstrating “high variability in the knowledge and understanding of English neuropathic terminology by moderately educated native isiZulu speakers who spoke English as their second language.” The authors believe that the translation of existing questionnaires into isiZulu and other South African languages is a “legitimate pursuit.” (89)

## **2.9 Record keeping**

The Medical Protection Society of the United Kingdom, reports the main purpose of any clinical record to be continuity of care for patients, but they also report other uses as follows:

- administrative and managerial decision making within the National Health System
- meeting current legal requirements, including enabling patients to access their records
- assisting in clinical audit
- supporting improvements in clinical effectiveness through research
- providing the necessary factual base for responding to complaints and clinical negligence claims. (90)

Clinical records are a basic clinical tool that also serves as a medicolegal document. It forms a permanent account of individual considerations and the reasons for decisions in patient

management and diagnosis (91). The Medical Protection Society of the United Kingdom, clearly states on its website that “in the event of a complaint, clinical negligence claim or disciplinary proceedings, the doctor’s defense will in large part depend upon the evidence available in the clinical records.” (90)

An audit by Raff and James (92), of anaesthetic records in a Cape hospital was conducted to determine the rate of completion and adequacy of record keeping. It was found that less than one third of all records were complete and legible, one quarter of all anaesthetics had no record keeping of any kind and in the remaining 45% the records were incomplete or illegible in some or all aspects (92). The emphasis on adequate clinical records has led to the development of a generic audit tool by the Royal College of Physicians, that is applicable to all clinical disciplines for auditing against the generic health record keeping standards (93).

In the developed world there has been a shift to electronic health databases. President George W. Bush, in 2004, announced plans to ensure that most Americans’ health records are computerised within 10 years and to create a National Health Information Network. In 2000, the WHO ranked the US 37<sup>th</sup> out of 191 and identified the poor use of information technology as among the primary reasons for this ranking. Electronic health databases have benefits and unique challenges. Benefits and challenges were documented by Harvard scholars Hoffman and Podgurski (94). Benefits include facilitating access to patient’s medical records, improving quality of care and reducing poor treatment decisions, cost savings and promoting research. Challenges include the potential for errors, privacy and security concerns, the expense, time burden and legal issues associated with health databases. (94)

A novel method of electronic health databases are palm scanners. This new technology has been adapted by nearly 200 hospitals in 40 health systems in the USA, and captures near-infrared images a patient’s hand and automatically links to the correct patient record. Palm scans eliminate duplicates because only one record can be attached to one palm scan. New York University’s Langone Medical Center, reports 80 000 records that were duplicated. They also found that time was saved off registration because once the patient was in the system, the palm reader took seconds to confirm the patients identity (95).

## **2.10 Importance of a clinical audit**

Internal audits are used as a measure to maintain quality standards and to improve service delivery over time. The National Institute of Clinical Excellence (NICE) has endorsed the following definition of a clinical audit: “A quality improvement process that seeks to improve

patient care and outcomes through systematic review of care against explicit criteria and the implementation of change. Aspects of the structure, processes and outcomes of care are selected and systematically evaluated against specific criteria. Where indicated, changes are implemented at an individual, team or service level and further monitoring is used to confirm improvement in healthcare delivery.” An audit should be a continuous cycle of improvement, designed to bring organisational change that will assist in clinical performance and service delivery. (96)

## **2.11 Summary**

In this chapter, the literature regarding chronic pain has been reviewed. An overview on the evolution of pain theories, the postulated mechanisms of chronic pain, a classification of chronic pain and the various causes of chronic pain are reviewed, with particular detail on CRPS, MPS, CLBP and FBSS. Thereafter, the literature on chronic pain internationally and within S.A was reviewed. This included the prevalence of chronic pain, gender and chronic pain, age and chronic pain, the economic impact of chronic pain and the impact of chronic pain on the individual and HIV/AIDS and chronic pain. The following chapter details the research design and methodology of this study.

# Chapter Three - Research Design and Methodology

## 3.1 Introduction

A detailed explanation of the research methodology is discussed under the headings of study design, study population and study sample (including sample size, sampling method, inclusion and exclusion criteria), description of data collection procedures and the planned statistical analysis of the data.

## 3.2 Problem statement

The Declaration of Montreal (Appendix I) declares that “access to pain management is a fundamental human right” and was supported by summit delegates from 129 countries at the 13<sup>th</sup> World Congress on Pain in Montreal (18, 19). A Human Rights Watch report estimated that 80% of the world’s population had either insufficient access or no access to treatment for moderate to severe pain (20). Internationally, chronic pain is being recognised as a crisis and policies are being implemented to address this issue in developed countries. The Human Rights Watch calls for governments to address this crisis under international human rights law (20).

Comprehensive information is needed on the epidemiology and burden of chronic pain in the population for the development of appropriate health interventions. S.A currently lacks the epidemiological data to support lobbying for chronic pain as a public health priority, and auditing the HJHPMU is a step towards addressing the paucity of epidemiological data on chronic pain in S.A. The data obtained will also give us an opportunity to compare the epidemiology of chronic pain in the South African population with international studies.

## 3.3 Aim

The aim of this study was to describe the profile of chronic pain patients at the HJHPMU for 2011 and to determine the adequacy of record keeping.

## 3.4 Objectives

The primary objectives of this study were to determine the:

- number of pre-existing and new patients consulted in 2011
- demographic profile of patients attending the HJHPMU (age and gender)
- presenting complaint of patients



- diagnosis
- relevant medical history
- relevant surgical history
- type of pain.

The secondary objective of this study was to determine the adequacy of record keeping.

### **3.5 Demarcation of study field**

This study was conducted at the HJHPMU. Helen Joseph Hospital has 512 beds and is affiliated to the University of the Witwatersrand. The HJHPMU is a large multidisciplinary unit, comprising of pain specialists, a social worker, psychologist, group therapy councillor, physiotherapist and occupational therapist. They accept referrals from medical professionals and allied health professionals from other Gauteng hospitals.

### **3.6 Ethical considerations**

Approval to conduct this study was obtained from the Postgraduate Committee (Appendix II) and the Human Research Ethics Committee (Medical) of the University of the Witwatersrand (Appendix III), as well as the Chief Executive Officer of Helen Joseph Hospital (Appendix IV).

The Head of the Helen Joseph Anaesthesiology Department and HJHPMU were approached for written consent to access patients' files and the patient database (Appendix V).

This study did not involve any drug or therapeutic management, and was conducted by adhering to South African Good Clinical Practice Guideline (97) and the Declaration of Helsinki (24). Therefore no consent from patients was required.

### **3.7 Research methodology**

#### **3.7.1 Research design**

A retrospective, contextual, descriptive study design was utilised.

A research design has been described as the blueprint for the study (93). Brink describes a research design as the methods by which the researcher obtains subjects, collects data, analyses data and interprets results (90).

## **Retrospective**

A retrospective study investigates a phenomenon, situation, problem or issue that has happened in the past, conducted on the basis that data is available for that period (98). This study will be retrospective in design as data recorded in the pain management unit's database in 2011 will be analysed.

## **Contextual**

A contextual study is one that takes place in a specific location. This may impact on the validity of the study by limiting generalisability. This study is contextual as it is limited to the HJHPMU.

## **Descriptive**

A descriptive study aims to describe a situation or identify problems through observation, description or classification without manipulating variables (90, 93). No treatment or intervention is tested (93). This study is descriptive as it will be describing the patient profile for the HJHPMU for 2011.

### **3.7.2 Study population**

The HJHPMU database and files for patients consulted during the period January 2011 to December 2011. The estimated number of files is 430.

### **3.7.3 Study sample**

A consecutive sampling method was used and the study sample included the HJHPMU database and all files of adult patients that attended the HJHPMU during the period January 2011 to December 2011.

### **3.7.4 Inclusion and exclusion criteria**

For the purpose of this study, the files of adult patients 18 years and older will be included in the study. Patient files were excluded from the audit if not enough information could be extracted e.g. missing or illegible data.

### **3.7.5. Description of data collection**

An audit was conducted on the demographic profile of chronic pain patients attending the HJHPMU. The HJHPMU database and files were accessed during the period of November 2012 to January 2013. Data were entered onto a data capture sheet (Appendix VI) and then onto Microsoft Excel for Mac 2011 spreadsheets. Strict confidentiality was maintained at all times. The following data were collected:

- study number
- number of pre-existing and new patients consulted in 2011
- demographic profile of patients attending the HJHPMU (age and gender)
- presenting complaint of patients
- diagnosis
- relevant medical history
- relevant surgical history
- type of pain.

The National Institute for Clinical Excellence defines an audit as “A quality improvement process that seeks to improve patient care and outcomes through systematic review of care against explicit criteria and the implementation of change. Aspects of the structure, processes and outcomes of care are selected and systematically evaluated against specific criteria. Where indicated, changes are implemented at an individual, team or service level and further monitoring is used to confirm improvement in healthcare delivery.” (96)

### **3.7.6 Data Analysis**

Data were analysed using Statistica 10.0, a statistical program, in consultation with a biostatistician. Descriptive statistics were used to analyse the data obtained during the study. Frequencies and percentages will be reported. A Chi-squared test was utilised to analyse any association between gender and type of pain and a level of significance of 0,05 was used.

## **3.9 Validity and reliability of the study**

### **Validity**

Validity is the extent to which the instrument actually reflects or measures what it is supposed to measure (99).

## **Reliability**

Reliability is concerned with how consistently the measurement technique measures a variable or concept.

Validity and reliability of the study were ensured, in that one researcher collected the data. This ensured standardisation of the data collected. An appropriate study design was chosen. A sample size was determined with the consultation of a biostatistician. A Microsoft Excel spreadsheet was utilised in computing data directly and the data were then rechecked every 20<sup>th</sup> entry. Data were analysed in consultation with a biostatistician.

## **3.11 Summary**

A detailed explanation of the research methodology has been presented under the headings of study design, study population and study sample (including sample size, sampling method, inclusion and exclusion criteria), description of data collection and the planned statistical analysis of the data. The following chapter details the data analysis and discussion of the results of the study.

# Chapter Four - Results and discussion

## 4.1 Introduction

In this chapter the results of this study are reported and discussed. Results will be discussed as per the objectives of this study, however the secondary objective will be discussed first as this affected sample realization.

The primary objectives of this study were to determine the:

- number of pre-existing and new patients consulted in 2011
- demographic profile of patients attending the HJHPMU (age and gender)
- presenting complaint of patients
- diagnosis
- relevant medical history
- relevant surgical history
- type of pain.

The secondary objective of the study was to determine the adequacy of record keeping.

## 4.2 Secondary Objective

### Adequacy of record keeping

The number of patients in the HJHPMU database for 2011 was noted to be 475 adult patients. Due to illegible handwriting in the HJHPMU database and repetition, there were 109 (22.95%) patients excluded from the study sample. Another 81 (17,05%) patients were excluded from the study due to missing data such as no hospital number recorded, no initials to a surname, or the file not found. This resulted in a study sample of 285 patients. Thus, the interpretation of the results from the primary objectives must be examined with prudent circumspection.

## 4.3 Primary Objectives

### 4.3.1 Number of pre-existing and new patients consulted in 2011

For the year 2011, out of the 285 patients included in the study, the HJHPMU had 215 (75,44%) pre-existing patients and 70 (24,56%) new patients.

### 4.3.2 Demographic profile of patients attending the HJHPMU (Age and gender)

#### Age

The age distribution for patients is depicted in Table 4.1. There were 47 (16,49%) patients in the 18-40 year age group. The preponderance of patients were in the 41-60 year age group, with 146 (51,23%) of patients presenting in this age group. There were 92 (32,28%) patients aged above 60 years.

#### Gender

Of the 285 patients in the study, 91 (31,93%) patients were male and 194 (68,07%) were female. For both females and males prevalence peaked in the 41-60 years age group, at 95 (33,33%) and 51 (17,90%) respectively.

Table 4.1 summarises the gender distribution of patients in different age groups. In the 18-40 year age group, there were 27 (9,47%) female patients and 20 (7,02%) male patients. In the 41-60 year age group, there were 95 (33,33%) female patients and 51 (17,90%) male patients. In those patients older than 60 years of age, 72 (25,26%) patients were female and 20 (7,01%) patients were male.

Age group	Number of females (%)	Number of males (%)	Total number of patients (%)
18-40 years	27 (9,47)	20 (7,02)	47 (16,49)
41-60 years	95 (33,33)	51 (17,90)	146 (51,23)
>60 years	72 (25,26)	20 (7,01)	92 (32,28)

**Table 4.1** Age and gender distribution of patients at HJHPMU.

### 4.3.3 Presenting complaint of patients

Presenting complaints included the following:

- abdominal pain
- cervical spine pain

- chest pain
- facial pain
- generalised body pain
- headache
- LBP
- lower extremity pain
- scar pain
- thoracic spine pain
- upper extremity pain
- vulval pain.

All 285 patients had documented presenting complaints. Some patients presented with more than one presenting complaint and therefore the data in Table 4.2 does not equate to the sample size of 285. The most common presenting complaint of patients at the HJHPMU was LBP (n=153). This was true for all age groups. LBP was also the predominant complaint for both males and females.

Table 4.2 describes the percentage of patients for each presenting complaint. Of the 285 patients, there were 153 (53,68%) patients with LBP, 53 (18,60%) with lower extremity pain, 43 (15,09%) with upper extremity pain, 28 (9,83%) with cervical spine pain, 13 (4,56%) with headache, 11 (3,86%) with facial pain, 8 (2,81%) with abdominal pain, 8 (2,81%) with chest pain, 8 (2,81%) with generalised body pain, 7 (2,46%) with thoracic spine pain, 4 (1,40%) with vulval pain and 1 (0,35%) with scar pain.

<b>Presenting complaint</b>	<b>Number of patients (%)</b>
LBP	153 (53,68)
Lower extremity pain	53 (18,60)
Upper extremity pain	43 (15,09)
Cervical spine pain	28 (9,83)
Headache	13 (4,56)
Facial pain	11 (3,86)
Abdominal pain	8 (2,81)
Chest pain	8 (2,81)
Generalised body pain	8 (2,81)
Thoracic spine pain	7 (2,46)
Vulval pain	4 (1,40)
Scar pain	1 (0,35)

**Table 4.2** Presenting complaint of patients at HJHPMU.

#### **4.3.4 Diagnosis**

Some patients had a differential diagnosis or more than one diagnosis. A total of 8 patients had no diagnosis in their files. For these reasons the data reflected in Table 4.3 does not equate to the sample size of 285. For purposes of analysis, LBP, thoracic spine pain, cervical pain, cervicgia, sacral pain, cauda equina and thoracic outlet syndrome with demyelination of the ulnar nerve were grouped together as spinal pain. If a patient had previous back or neck surgery and their complaint related to this, they were grouped as FBSS. Those patients who were grouped under the diagnosis of headache included post traumatic headache, tension headaches, chronic headache and migraine. Osteoarthritis, ankylosing spondilitis, degenerative arthritis, chostochondritis, osteoporosis and rheumatoid arthritis were grouped under the diagnosis of arthritis.

Table 4.3 illustrates the number of patients with each diagnosis. The HJHPMU had 97 (34,04%) patients with spinal pain, 59 (20,70%) with FBSS, 40 (14,04%) patients with arthritis, 31 (10,88%) patients with peripheral neuropathy, 17 (5,97%) with CRPS, 10 (3,51%) with post herpetic neuralgia, 10 (3,51%) with post surgical pain, 6 (2,11%) with central pain, 6 (2,11%) with headache, 6 (2,11%) with myofascial pain, 6 (2,11%) with trigeminal neuralgia, 6 (2,11%) with visceral pain, 5 (1,75%) with a brachial plexus injury and 1 (0,35%) with osteogenesis imperfecta.



<b>Diagnosis</b>	<b>Number of patients (%)</b>
Spinal pain	97 (34,04)
FBSS	59 (20,70)
Arthritis	40 (14,04)
Peripheral neuropathy	31 (10,88)
CRPS	17 (5,97)
Post herpetic neuralgia	10 (3,51)
Post surgical pain	10 (3,51)
Central pain	6 (2,11)
Headache	6 (2,11)
Myofascial pain	6 (2,11)
Trigeminal neuralgia	6 (2,11)
Visceral pain	6 (2,11)
Brachial plexus injury	5 (1,75)
Osteogenesis imperfecta	1 (0,35)

**Table 4.3** The diagnosis of patients at HJHPMU.

The most prevalent diagnosis for any age group and for both genders was spinal pain (males n=20; females n =77). This included patients with a diagnosis that related to cervical, thoracic or lumbar pain, however excluded FBSS. The second most prevalent diagnosis made at HJHPMU was FBSS. This was true for both genders (males n=23; females n=36) and for those patients more than 40 years of age. For the age group 21-40 years, peripheral neuropathy and CRPS were equally prevalent.

#### **4.3.5 Relevant medical history**

Of the 285 patients included in this study, 176 (61,75%) of these patients had a relevant medical history. With the large amount of heterogeneity in patients' medical history, chronic medical conditions that could contribute or developed as a consequence of the underlying pathology were also included in this subset of data. Table 4.4 illustrates the distribution of medical conditions for patients at the HJHPMU. There were 86 (30,18%) patients with hypertension (HT), 32 (11,23%) had Diabetes Mellitus (DM), 32 (11,23%) had peptic ulcer disease/gastroesophageal reflux disease, 10 (3,51%) had a malignancy, 8 (2,81%) patients with a psychiatric disorder, 6 (2,11%) had HIV, and 2 (0,70%) patients had rheumatoid arthritis.

<b>Relevant medical history</b>	<b>Number of patients (%)</b>
Hypertension	86 (30,18)
Diabetes Mellitus	32 (11,23)
Peptic ulcer disease/gastroesophageal reflux disease	32 (11,23)
Malignancy	10 (3,51)
Psychiatric disorders	8 (2,81)
HIV	6 (2,11)
Rheumatoid arthritis	2 (0,70)

**Table 4.4** Relevant medical history of patients presenting to HJHPMU.

All patients with psychiatric disorders were females and were older than 41 years of age. Peptic ulcer disease and gastroesophageal reflux disease were more common in females (n=27) than males (n=5). Of the patients infected with HIV, 5 (83,33%) of these patients presented with a peripheral neuropathy and 1 (16,67%) presented with post herpetic neuralgia.

#### **4.3.6 Relevant surgical history**

Of the 285 patients, 164 (57,54%) patients had a relevant surgical history. A relevant surgical history was defined as patients who had trauma or surgery that contributed to the pain condition. From the 164 patients, 46 (28,05%) patients had been involved in a traumatic event. The traumatic events included 24 (8,42%) of patients involved in a motor vehicle accident, 4 (1,40%) patients involved in a pedestrian vehicle accident and 18 (6,32%) patients with a history of assault. From the data sample, 61 (37,20%) patients had a surgery, other than spinal surgery, which was relevant to their pain diagnosis. Seventy-one patients (43,29%) had a spinal surgery that was relevant to their diagnosis. From the 71 patients, 61 (21,40%) patients had previous back surgery, 9 (3,16%) had previous cervical spine surgery and 1 (0,35%) had previous thoracic spine surgery. Table 4.5 illustrates the percentage of patients at HJHPMU with a relevant surgical history.

Relevant surgical history	Number of patients (%)
Back surgery	61 (21,40)
Other relevant surgery	47 ( 16,49)
Motor vehicle accident	24 (8,42)
Assault	18 (6,32)
Cervical spine surgery	9 (3,16)
Paedestrian vehicle accident	4 (1,40)
Thoracic spine surgery	1 (0,35)

**Table 4.5** Percentage of patients at HJHPMU with a relevant surgical history.

#### 4.3.7 Type of pain

The type of pain the patient presented with was described as neuropathic, nociceptive or mixed. Of the 285 patients, 250 (87,72%) had the type of pain described, while 35 (12,28%) patients had no description of the type of pain noted in the file. The most common type of pain described was a mixed type of pain and was diagnosed in 113 (39,65%) patients that presented to the HJHPMU. This was followed by 80 (28,07%) patients with neuropathic pain and 57 (20%) patients with nociceptive pain. This data is represented in Figure 4.1.

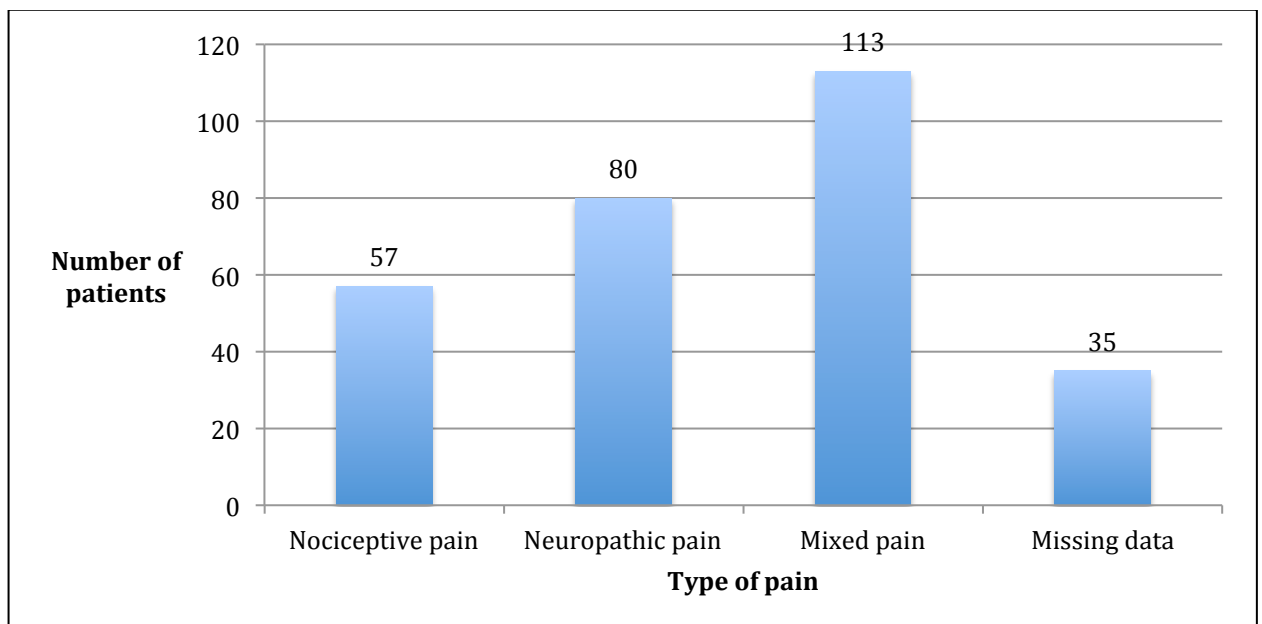

**Figure 4.1** The number of patients at HJHPMU presenting with each type of pain.

Neuropathic pain was the most common type of pain in male patients (n=39), while female patients presented with mostly mixed pain (n= 77). Table 4.6 illustrates the distribution of the different types of pain and gender. There were 46 (16.14%) female patients with nociceptive pain, 41 (14.39%) with neuropathic pain, 77 (27.02%) with mixed data and 30 (10.53%) patients with missing data. Amongst the male patients, there were 11 (3.86%) with nociceptive pain, 39 (13.68%) with neuropathic pain, 36 (12.63%) with mixed pain and 5 (1.75%) with missing data. A Chi-squared test was performed to ascertain if there is a relationship between gender and the type of pain, and a p value of 0.001 was found which was statistically significant.

<b>Gender</b>	<b>Number with nociceptive pain (%)</b>	<b>Number with neuropathic (%)</b>	<b>Number with mixed (%)</b>	<b>Number with missing data (%)</b>
Female	46 (16,14)	41 (14,39)	77 (27,02)	30 (10,53)
Male	11 (3,86)	39 (13,68)	36 (12,63)	5 (1,75)

**Table 4.6** Type of pain related to gender at HJHPMU.

When relating the type of pain with age, mixed pain and nociceptive pain was found to be most common in those aged >60 years (n=26), whereas neuropathic pain was found to be most common in the 41-60 year age group (n=43).

Table 4.7 relates the type of pain and the age of the patient. In the 18-40 year age group, there were 7 (2.46%) patients with nociceptive pain, 18 (6.32%) with neuropathic pain, 17 (5.97%) with mixed pain and 5 (1.75%) with missing data. In those aged between 41-60 years, 24 (8.42%) had nociceptive pain, 43 (15.09%) neuropathic pain, 63 (22.11%) with mixed pain and 16 (5.61%) with missing data. Amongst those patients above 60 years of age, 26 (9.12%) patients had nociceptive pain, 19 (6.67%) had neuropathic pain, 33 (11.58%) had mixed pain and 14 (4.91%) patients had missing data.

Age groups	Number with nociceptive pain (%)	Number with neuropathic pain (%)	Number with mixed pain (%)	Number with missing data (%)
18-40	7 (2,46)	18 (6,32)	17 (5,97)	5 (1,75)
41-60	24 (8,42)	43 (15,09)	63 (22,11)	16 (5,61)
>60	26 (9,12)	19 (6,67)	33 (11,58)	14 (4,91)

**Table 4.7** Type of pain related to age groups at HJHPMU.

The results for the study will now be discussed.

#### 4.4 Discussion

The number of patients in the HJHPMU database for 2011 was noted to be 475 adult patients. For the year 2011, the HJHPMU had 215 (75,44%) pre-existing patients and 70 (24,56%) new patients. There were 190 (40,13%) patients excluded from the study due to illegible handwriting in the HJHPMU database, repetition, missing data, no hospital number, no initials to a surname or the file not found. This resulted in 285 patients (60%) from the original 475 patients being included in the study. Thus the results of this study should be examined with caution.

The large number of excluded patients should be a reminder of one of the fundamentals of clinical practice, which is the adequacy of record keeping. Many of the exclusions of this study could be avoided in the future. Improving record keeping and writing legibly are two factors that are avoidable. An audit by Raff and James (92), of anaesthetic records in a Cape hospital was conducted to determine the rate of completion and adequacy of record keeping. It was found that less than one third of all records were complete and legible, one quarter of all anaesthetics had no record keeping of any kind and in the remaining 45% the records were incomplete or illegible in some or all aspects. Although the figures from the HJHPMU for illegible or missing data is exceeded by those reported by Raff and James (92), missing or illegible data can pose serious medicolegal consequences and is a problem that needs to be addressed.

Clinical records are a basic clinical tool that also serves as a medicolegal document. It forms a permanent account of individual considerations and illustrates the reasons for decisions in

patient management and diagnosis. (91) The Medical Protection Society of the United Kingdom, clearly states that “in the event of a complaint, clinical negligence claim or disciplinary proceedings, the doctor’s defense will in large part depend upon the evidence available in the clinical records.” (90) Thus adequate clinical records are imperative to patient care and to safeguard the doctor in the event of a legal claim. This is an area of potential improvement at the HJHPMU, as 190 (41.3%) patients were excluded due to inadequate record keeping.

The HJHPMU database and all clinical records are paper based. In the developed world there has been a shift to electronic health databases and this has been advocated by heads of states in the developed world (94). New York University’s Langone Medical Center reports that after the implementation of a novel electronic health database, 80 000 records that were duplicated were discovered. They also found time was saved during registration because once the patient was in the system, the electronic database took seconds to confirm the patients identity. (95) Electronic health databases albeit their advantages, presents clinicians with unique challenges. They are not without the potential for human error, they have privacy and security concerns as well as legal concerns (94). Implementation of an electronic database at HJHPMU may require computer literacy training for staff members. The large initial expense of implementing the system may be a potential limitation in introducing electronic health databases to the HJHPMU. Electronic health databases can be useful to save time during the consultation process, however one would require a database specifically designed for chronic pain patients. Easy to use drop boxes and tick boxes can be time saving.

There were 70 (24,56%) patients who were new to the clinic in 2011, which could possibly reflect the time constraints of the clinic. This could possibly be explained by the structuring of the HJHPMU questionnaire, language barriers, staffing limitations and the referral system of the HJHPMU. The MPQ was developed for a first world healthcare setting, where patients take the questionnaire home and bring it back to the clinic completed. The South African population is unique in that there are eleven official languages and transport to the hospital is a problem for those unemployed. If the HJHPMU were to use the McGill questionnaire that involves taking it home to complete, the HJHPMU is unlikely to see the patient for follow up. This makes developing a questionnaire that all patients can understand and complete a difficult task and sets S.A apart from other countries. Due to time constraints and language barriers, the HJHPMU uses a modification of the MPQ, adapted by Frohlich (Appendix VII). This modification requires the pain specialist to ask the patient questions and for the pain specialist to fill these in. The specialist then examines the patient and a diagnosis or

differential diagnosis is assimilated. Thereafter, the administrative task of filling out prescriptions, motivation for prescriptions as well as counselling lies with the specialist. On average, the first appointment with a new patient takes one hour (excluding administrative tasks) and a follow up appointment takes 30 minutes. When there is a registrar in the HJHPMU, the task of teaching the registrar lies with the specialist and this can extend the consultation time. Hence, the completion of this questionnaire by the pain specialist may be a time consuming process, however it is necessary to serve the South African population and its unique challenges.

The HJHPMU is also limited by the number of staff. There is one full time registered nurse, who also has the task of administrative clerk, one full time pain specialist and three part time pain specialists. This could possibly reflect the limited resources within the HJHPMU, and could account for the limited number of new patients.

The HJHPMU is a referral based unit and knowledge of chronic pain as a sub-speciality is growing in S.A. Unfortunately, chronic pain is introduced to medical students in only one lecture during their fifth year. At a specialist level, only training anaesthesiologists rotate through the HJHPMU for a total of one to two weeks and no other speciality has exposure to the HJHPMU. If training doctors and specialists are exposed to the HJHPMU and what role it has in the treatment of chronic pain, a rise in the number of referrals may be seen.

Varying patterns for the age distribution of chronic pain sufferers have been found internationally, however all countries have shown that the majority of patients are over the age of 40. Reasons for this could be the use of differing age strata, different definitions of chronic pain applied and probably also reflect the underlying populations structures. Igumba et al (3) found there to be a marked increase in the prevalence of chronic pain after the age of 55 years and in the age group 25 years or less, in the rural region of Ngwalizwe, Mthatha. Walker et al (16), found in the Free State in 2005, that the majority of pain sufferers were females between the ages of 41 and 60 years. The HJHPMU also found the majority of patients to be in the 41-60 year age group, with 146 (51.04%) patients presenting in this age group. Perhaps, the variation in South African data can be accounted for by the populations studied and the study design. In the study by Igumba et al (3), face-to-face interviews were conducted and a random sampling technique was utilised in the rural region of Ngwalizwe whereas, the study by Walker et al (16) was conducted in an urban South African Pain Control Unit at Universitas hospital, Bloemfontein. This is similar to the population that the HJHPMU serves in an urban South African setting, Johannesburg.

International studies have shown a varying gender distribution for chronic pain, with some countries finding an equal gender distribution (7, 67) and most countries showing a female preponderance (7, 51, 60, 61). Patients attending the HJHPMU from 2005 to the 1<sup>st</sup> of December 2008, had a gender distribution that was predominately female (59%) (82). The results of this study however should be viewed with circumspection, as the quality of record keeping at the HJHPMU is inadequate. A study conducted at Universitas Hospital Pain Control Unit in the Free State in 2005, found that the majority of pain sufferers are females between the ages of 41 and 60 years (16). Igumba et al (3), found in the Eastern Cape, that 58,6% of patients with chronic pain were female. HJHPMU has a predominance of female patients, which is in keeping with what international and national studies have demonstrated. Our findings related to the age and gender distribution of chronic pain sufferers appears to be similar to other studies internationally and locally. An interesting finding was that a clinically significant association (p value of 0.001) was found between the type of pain a patient presents with and the gender of the patient.

The most common presenting complaint was LBP (52,68%). Lower extremity pain (18,60%) followed by upper extremity pain (15,09%) were the second and third most common presenting complaints. All of these complaints were more common in the female population and in the age group 41-60 years old. The majority of patients had a diagnosis of spinal pain (34,04%), followed closely by FBSS (20,70%). du Plessis et al (82), found that 83% of referrals to HJHPMU during a 3 year period was from the orthopaedic department at Helen Joseph hospital. Walker et al (16), in the Free State reported that 49,28% of patients at the Universitas Hospital Pain Management Unit had been diagnosed with CLBP. Blythe et al (51) found that 45% of patients with chronic pain, experienced back pain. FBSS and CLBP is a global problem, draining health resources worldwide.

An interesting finding with respect to the medical history of patients, was the relatively high number of patients with peptic ulcer disease or gastroesophageal reflux disease (11,32%). These patients were diagnosed clinically and no special investigations were done to confirm the diagnosis due to budgetary constraints. This however does raise the question of non-steroidal anti-inflammatory (NSAID) abuse amongst chronic pain patients. The HJHPMU does not prescribe NSAIDs to chronic pain patients, however patients seen at the HJHPMU have generally been consulted by many clinicians before being referred to the HJHPMU, who could be prescribing NSAIDs. The inappropriate administration of NSAIDs has been described as widespread in S.A by Chetty et al (41). Over the counter access and other physicians treating



these patients' pain with NSAIDs could be at the source of the problem.

All patients with psychiatric disorders were females and were older than 41 years of age, and these totaled 2.81% of patients. At the HJHPMU, a psychologist is utilized to try and identify the need for a psychiatric evaluation. Limitations primarily secondary to service load, makes getting all patients evaluated unfeasible and may account for the lower number of patients identified with psychiatric disorders.

Studies suggest that 25 - 30% of outpatient and/or ambulatory patients with early HIV disease experience clinically significant pain, and estimates of pain among patients infected with HIV/AIDS have been reported to range from 30% to over 90% (84, 85). HIV is endemic to S.A and the relatively lower rates of HIV at HJHPMU (2,11%) raises the question of whether offering voluntary HIV testing at each visit should be incorporated into the Pain Questionnaire. Offering patients a HIV test at each visit is not routine practice at the HJHPMU. Helen Joseph Hospital runs a HIV clinic and perhaps one of the reasons for the lower prevalence rates at HJHPMU is that the HIV clinic is treating these patients for their chronic pain.

Data on chronic pain in the developed world has been well established and the economic and social impact has captured the attention of governments globally. S.A however, has yet to identify chronic pain as a health priority. With the limited data from this study, it seems that the profile of patients with chronic pain in S.A does not grossly differ from data collected internationally. Although, it was not the scope of the study, the question arises as to the economic impact of chronic pain on a developing world where resources are already so limited.

## **4.5 Summary**

In this chapter the results of the study were reported and discussed. In the following and final chapter a summary, the limitations, recommendations and conclusions of the study are presented.

## **Chapter Five - Summary, Limitations, Recommendations and Conclusion**

### **5.1 Introduction**

In this chapter a summary, limitations, recommendations and conclusion will be presented.

### **5.2 Summary of the study**

#### **5.2.1 The aim of the study**

The aim of this study was to describe the profile of chronic pain patients at the HJHPMU for 2011 and to determine the adequacy of record keeping.

#### **5.2.2 Objectives of the study**

The primary objectives of this study were to determine the:

- number of pre-existing and new patients consulted in 2011
- demographic profile of patients attending the HJHPMU (age and gender)
- presenting complaint of patients
- diagnosis
- relevant medical history
- relevant surgical history
- type of pain

The secondary objective of this study was to determine the adequacy of record keeping.

### **5.2.3 Summary of the methodology used in the study**

The research design was that of a retrospective, contextual, descriptive design. The HJHPMU database and files were utilised to obtain data for patients consulted during the period January 2011 to December 2011. A consecutive sampling method was used and the study sample included the HJHPMU database and all files of patients that attended the HJHPMU. Patient files were excluded from the audit if not enough information could be extracted e.g. missing or illegible data.

Data were entered onto a data capture sheet (Appendix VI) and then onto Microsoft Excel for Mac 2011 spreadsheets. Strict confidentiality was maintained at all times. The following data were collected:

- study number
- number of pre-existing and new patients consulted in 2011
- demographic profile of patients attending the HJHPMU (age and gender)
- presenting complaint of patients
- diagnosis
- relevant medical history
- relevant surgical history
- type of pain.

Data were analysed using Statistica 10.0, a statistical program, in consultation with a biostatistician. Descriptive statistics were used to analyse the data obtained during the study. Frequencies and percentages were reported. A Chi-squared test was utilised to analyse any association between gender and type of pain and a level of significance of 0,05 was used.

### **5.2.4 Main findings of the study**

The number of patients in the HJHPMU database for 2011 was noted to be 475 adult patients. For the year 2011, the HJHPMU had 215 (75,44%) pre-existing patients and 70 (24,56%) new patients. There were 190 (40%) patients excluded from the study due to illegible handwriting in the HJHPMU database, repetition, missing data, no hospital number, no initials to a surname or the file not found. This resulted in only 285 patients (60%) of the original 475 patients being included in the study. Thus the results of this study should be examined with prudent circumspection. The large number of excluded patients alerts us to the unsatisfactory record keeping at HJHPMU.

There were 47 (16,49%) patients in the 18-40 year age group. The preponderance of patients were in the 41-60 year age group, with 146 (51,23%) patients presenting in this age group. There were 92 (32,28) patients aged above 60 years. Of the 285 patients in the study, 91 (31,93%) patients were male and 194 (68,07%) were female. For both females and males prevalence peaked in the 41-60 years age group, at 95 (33,33%) and 51 (17,90%) respectively.

Of the 285 patients, there were 153 (53,68%) patients with LBP, 53 (18,60%) with lower extremity pain, 43 (15,09%) with upper extremity pain, 28 (9,83%) with cervical spine pain, 13 (4,56%) with headache, 11 (3,86%) with facial pain, 8 (2,81%) with abdominal pain, 8 (2,81%) with chest pain, 8 (2,81%) with generalised body pain, 7 (2,46%) with thoracic spine pain, 4 (2,40%) with vulval pain and 1 (0,35%) with scar pain. The HJHPMU had 97 (34,04%) patients with spinal pain, 59 (20,70%) with FBSS, 40 (14,04%) patients with arthritis, 31 (10,88%) patients with peripheral neuropathy, 17 (5,97%) with CRPS, 10 (3,51%) with post herpetic neuralgia, 10 (3,51%) with post surgical pain, 6 (2,11%) with central pain, 6 (2,11%) with headache, 6 (2,11%) with myofascial pain, 6 (2,11%) with trigeminal neuralgia, 6 (2,11%) with visceral pain, 5 (1,75%) with a brachial plexus injury and 1 (0,35%) with osteogenesis imperfecta.

The most prevalent diagnosis for any age group and for both genders was spinal pain (males n=20; females n =77). This included patients with a diagnosis that related to cervical, thoracic or lumbar pain, however excluded FBSS. The second most prevalent diagnosis made at HJHPMU was FBSS and this was true for both genders (males n=23; females n=36) and for those patients more than 40 years of age.

All patients with psychiatric disorders were females and were older than 41 years of age. Peptic ulcer disease and gastroesophageal reflux disease were more common in females (n=27) than males (n=5). Of the patients infected with HIV, 5 (83,33%) patients presented with a peripheral neuropathy and 1 (16,67%) presented with post herpetic neuralgia.

Of the 285 patients, 164 (57,54%) patients had a relevant surgical history. From the 164 patients, 46 patients had been involved in a traumatic event. The traumatic events included motor vehicle accident (n=24), pedestrian vehicle accident (n=4) and assault (n=18). From our data sample, 47 patients had surgery, other than spinal surgery that was relevant to their pain diagnosis. Seventy-one patients had spinal surgery that was relevant to their diagnosis.

From the 71 patients, 61 (21,40%) patients had previous back surgery, 9 (3,16%) had previous cervical spine surgery and 1 (0,35%) had previous thoracic spine surgery. Of the 285 patients, 250 (87,72%) had the type of pain described, while 35 (12,28%) patients had no description of the type of pain noted in the file. The most common type of pain described was a mixed type of pain and was diagnosed in 113 (39,65%) patients that presented to the clinic. This was followed by 80 (28,07%) of the patients having neuropathic pain and 57 (20%) patients having nociceptive pain. Neuropathic pain was the most common type of pain in male patients (n=39), while females presented with mostly mixed pain (n=77).

### **5.3 Limitations of the study**

Due to the retrospective nature of the study, limitations included documentation that was incomplete, information that was unrecorded, difficulty interpreting information found in the documents (e.g. acronyms, illegible handwriting, jargon) and the assumption that data were collected accurately. Thus results should be interpreted judiciously. This study is contextual in nature and therefore results may not be generalised to other pain management units/clinics.

### **5.4 Recommendations from the study**

#### **5.4.1 Recommendations for clinical practice**

The most pertinent outcome from this study that can aid in clinical practice at HJHPMU is the quality of record keeping. The implementation of an electronic health care system should be considered as an alternative method of record keeping. Another alternative to this costly solution would be to add a single page at the front of each file summarising the patient's condition and demographic data (Appendix VIII). This is to allow data collection for research purposes to be quicker and easier. It is a simple information sheet where the physician can circle the appropriate parameter.

Regular audits of record keeping will help improve the quality of record keeping. Annual audits conducted will help to measure and maintain quality standards and to improve service delivery over time. The generic record keeping audit tool developed by the Royal College of Physicians is a suggested tool to utilise whilst conducting further audits at the HJHPMU (93). Exposing the HJHPMU to undergraduate and postgraduate students from other disciplines should be considered to improve and broaden referral systems to the HJHPMU.

#### **5.4.2 Recommendations for further research**

Should the above recommendations be introduced at HJHPMU, it is suggested that their implementation and impact be followed up. A recommended focus for further research would be to evaluate any improvements in record keeping at HJHPMU.

As HJHPMU has a population that has been diagnosed predominately with spinal pain and FBSS, a study investigating the frequency of surgery and the indications for surgery for CLBP patients will provide data that could potentially shed further light on why the HJHPMU is servicing a large number of FBSS patients. Further research in describing the economic impact of chronic pain in S.A is suggested, as this will help to campaign for chronic pain to be recognised as a health priority in S.A.

### **5.5 Conclusion**

The profile of chronic pain patients has been described, however the pertinence of good record keeping is a highlight of this study and is the key to accurate epidemiological descriptions.

## References

1. Access Economics. The high price of pain: the economic impact of persistent pain in Australia: MBF foundation in collaboration with the University of Sydney Pain Management Research Institute 2007.
2. Taskforce on taxonomy. Taxonomy: International Association for the Study of Pain 1994.
3. Igumba E, Puoane T, Gansky S, Plesh O. Chronic pain in the community; a survey in a township in Mthatha, Eastern Cape, South Africa. *South African Journal of Anaesthesia and Analgesia*. 2011;17(5).
4. Leavitt SB. Chronic Pain in America is a National Disgrace. 2011 [March 2012]; Available from: <http://updates.pain-topics.org/2011/07/chronic-pain-in-america-is-national.html>.
5. Sjogren P, Ekholm O, Peuckmann V, Gronbaek M. Epidemiology of chronic pain in Denmark: an update. *European Journal of Pain*. 2009 Mar;13(3):287-92.
6. Bergman S, Herrstrom P, Hogstrom K, Petersson IF, Svensson B, Jacobsson LT. Chronic musculoskeletal pain, prevalence rates, and sociodemographic associations in a Swedish population study. *The Journal of Rheumatology*. 2001 Jun;28(6):1369-77.
7. Mantyselka PT, Turunen JH, Ahonen RS, Kumpusalo EA. Chronic pain and poor self-rated health. *Journal of American Medical Association*. 2003 Nov 12;290(18):2435-42.
8. Harstall C. How prevalent is chronic pain. *Pain Clinical Updates*. 2003;XI(2):1-4.
9. Portenoy RK, Ugarte C, Fuller I, Haas G. Population-based survey of pain in the United States: differences among white, African American, and Hispanic subjects. *The Journal of Pain*. 2004 Aug;5(6):317-28.
10. Neville A, Peleg R, Singer Y, Sherf M, Shvartzman P. Chronic pain: a population-based study. *Israeli Medical Association Journal*. 2008 Oct;10(10):676-80.
11. Goldberg DS, McGee SJ. Pain as a global public health priority. *BioMed Central Public Health*. 2011;11:770.

12. World Health Organization. World Health Organization supports global effort to relieve chronic pain. 2004 [March 2012]; Available from: <http://www.who.int/mediacentre/news/releases/2004/pr70/en/>.
13. Societal Impact of Pain. Chronic pain as disease - politics or science. 2012 [May 2012]; Available from: <http://www.sip-platform.eu/latest-press-releases.html>.
14. Frohlich E, Shipton E. Can the development of pain management units be justified in an emerging democracy. South African Medical Journal. 2007;97(9):827-8.
15. Tsang A, Von Korff M, Lee S, Alonso J, Karam E, Angermeyer MC, et al. Common chronic pain conditions in developed and developing countries: gender and age differences and comorbidity with depression-anxiety disorders. Journal of Pain. 2008 Oct;9(10):883-91.
16. Walker S, Odendaal C, Esterhuysen K. Biographical, pain and psychosocial data for a South African sample of chronic pain patients. South African Journal of Anaesthesia and Analgesia. 2006;2:62-6.
17. Health Professions' Council of South Africa. Guidelines on the keeping of patient records. Pretoria2007 [December 2013]; Available from: [http://www.hpcs.co.za/downloads/conduct\\_ethics/rules/guidelines\\_patient.pdf](http://www.hpcs.co.za/downloads/conduct_ethics/rules/guidelines_patient.pdf).
18. International Association for the Study of Pain. Declaration of Montreal. Montreal2010 [June 2012]; Available from: <http://www.iasp-pain.org/Content/NavigationMenu/Advocacy/DeclarationofMontreal233al/default.htm>.
19. Pain Australia. Declaration of Montreal. 2010 [June 2012]; Available from: <http://www.painaustralia.org.au/advocacy/declaration-of-montreal.html>.
20. Human Rights Watch. "Please do not make us suffer anymore.." Access to pain treatment as a human right. 2009 [June 2012]; Available from: [http://www.soros.org/sites/default/files/pain\\_20090301.pdf](http://www.soros.org/sites/default/files/pain_20090301.pdf).
21. International Association for the Study of Pain. Desirable characteristics for pain treatment facilities. 2009 [June 2012]; Available from: <http://www.iasp-pain.org/AM/Template.cfm?Section=Home&Template=/CM/HTMLDisplay.cfm&ContentID=3011>.
22. Personal communication: Frohlich E. Head of Helen Joseph Hospital Pain Management Unit. 2012.
23. Department of Health. Guidelines for Good Practice in the Conduct of Clinical Trials with Human Participants in South Africa. Pretoria2006.



24. World Medical Association. Declaration of Helsinki. 2013 [December 2013]; Available from: <http://www.wma.net/en/30publications/10policies/b3/>.
25. Statistics SA. Mid-year population estimates. 2010 [September 2012]; Available from: <http://www.statssa.gov.za/publications/P0302/P03022010.pdf>.
26. Moayed M, Davis K. Theories of pain: from specificity to gate control. *Journal of Neurophysiology*. 2013;109:5-12.
27. Gatchel RJ, Howard K. *The Biopsychosocial Approach to Pain Management*. University of Texas at Arlington; 2010.
28. Melzack R, Wall PD. Pain mechanisms: a new theory. *Science*. 1965 Nov 19;150(3699):971-9.
29. Melzack R. Pain and the neuromatrix in the brain. *Journal of Dental Education*. 2001 Dec;65(12):1378-82.
30. Turk DC. A diathesis-stress model of chronic pain and disability following traumatic injury. *Pain Research and Management*. 2002 Spring;7(1):9-19.
31. Engel GL. The need for a new medical model: a challenge for biomedicine. *Science*. 1977 Apr 8;196(4286):129-36.
32. Raspe H, Kohlmann T. Disorders characterised by pain: a methodological review of population surveys. *Journal of Epidemiology and Community Health*. 1994 Dec;48(6):531-7.
33. Harris RE. Central pain states: a shift in thinking about chronic pain. *The Journal of Family Practice*. 2011 Sep;60(9 Suppl):S37-42.
34. Meyr AJ, Saffran B. The pathophysiology of the chronic pain cycle. *Clinics in Podiatric Medicine and Surgery*. 2008 Jul;25(3):327-46.
35. Tegeder I, Costigan M, Griffin RS, Abele A, Belfer I, Schmidt H, et al. GTP cyclohydrolase and tetrahydrobiopterin regulate pain sensitivity and persistence. *Nature Medicine*. 2006 Nov;12(11):1269-77.
36. Mogil JS, Yu L, Basbaum AI. Pain genes?: natural variation and transgenic mutants. *Annual Review of Neuroscience*. 2000;23:777-811.
37. Vadivelu N, Christian J, Sinatra R. *Pain physiology and pharmacology*: Cambridge University Press; 2009.
38. Odendaal C. Neuropathic Pain. *South African Journal of Anaesthesia and Analgesia*. 2002;8(2).

39. Pain Australia. National Pain Strategy 2010. [September 2011] Available from: <http://www.painaustralia.org.au/the-national-pain-strategy/national-pain-strategy.html>
40. International Association for the Study of Pain. Task Force on Taxonomy- Classification of Chronic Pain: descriptions of chronic pain syndromes and definition of pain terms. IASP Press; 1994 [March 2012].
41. Chetty S, Baalbergen E, Bhigjee A, Kamerman P, Ouma J, Raath R, et al. Clinical practice guidelines for management of neuropathic pain: expert panel recommendations for South Africa. May 2012;102(5):312-25.
42. Schwarzer A, Maier C. Complex Regional Pain Syndrome. International Association for the Study of Pain: Guide to Pain Management in Low-resource Settings. [ March 2012] Available from: <http://www.iasp-pain.org/AM/Template.cfm?Section=Guide to Pain Management in Low Resource Settings&Template=/CM/ContentDisplay.cfm&ContentID=12172>
43. Mitchell S. Injuries of their nerves and their consequences. Lippincott J, editor. Philadelphia 1872.
44. Harden R, Bruehl S. CRPS: Current diagnosis and therapy. Diagnostic Criteria: the statistical derivation of the four criterion factors. Progress in pain research and development. 2005;32:45-58.
45. Borg-Stein J. Treatment of fibromyalgia, myofascial pain, and related disorders. Archives of Physical Medicine and Rehabilitation. May 2006;83(3):S40-7.
46. Borg-Stein J, Simons D. Focused review: myofascial pain. Archives of Physical Medicine and Rehabilitation. March 2002;83(Supplement 1):S40-7.
47. Giamberardino M, Affaitati G, Fabrizio A, Costantini R. Myofascial pain syndromes and their evaluation. Best practice and research: Clinical Rheumatology. April 2011;25(2):185-98.
48. Duffy R. Low back pain: an approach to diagnosis and management. Primary Care Clinics in Office Practice. December 2010;37(4):729-41.
49. Deyo R, Gray D, Kreuter W, Mirza S, Martin BS. US Trends in lumbar fusion surgery for degenerative conditions. Spine. 2005;30:1441-5.
50. Stevans J, Saper R. Chronic Low Back Pain. 3rd ed. Rakel D, editor. Philadelphia: Saunders; 2012.

51. Blyth FM, March LM, Brnabic AJ, Jorm LR, Williamson M, Cousins MJ. Chronic pain in Australia: a prevalence study. *Pain*. 2001 Jan;89(2-3):127-34.
52. Buyton V. Neurostimulation for Chronic Neuropathic Back Pain in Failed Back Surgery Syndrome. *Journal of Pain and Symptom Management* April 2006;31(4S).
53. Chang C, Peng P. Review Article: Failed Back Surgery Syndrom. *Pain Medicine*. 2011;12:577-606.
54. National Center for Health Statistics. National Hospital Discharge Survey. Department of Health and Human Services. Center for Disease Control. Series 13. Number 144. Washington DC: U.S. 1997
55. Keller R, Atlas S, Soule D, Singer D, Deyo R. Relationship between rates and outcomes of operative treatment of lumbar disc herniation and spinal stenosis. *American journal of bone and joint surgery*. 1999;81:752-62.
56. Burton C. Editorial: Failed back surgery patients: the alarm bells are ringing. *Surgical Neurology*. 2006;65:5-6.
57. Russell S, Tarczynska M, Frohlich E. Case Study: The backache of Failed Back Surgery Syndrome (FBSS). *Journal of Pain SA*. 2012;7(2):21-5.
58. Abu-Saad Huijer H. Chronic pain: a review. *Lebanese Medical Journal*. 2010 Jan-Mar;58(1):21-7.
59. Wong WS, Fielding R. Prevalence and characteristics of chronic pain in the general population of Hong Kong. *Journal of Pain*. 2011 Feb;12(2):236-45.
60. Rustoen T, Wahl AK, Hanestad BR, Lerdal A, Paul S, Miaskowski C. Gender differences in chronic pain--findings from a population-based study of Norwegian adults. *Pain Management Nursing*. 2004 Sep;5(3):105-17.
61. Breivik H, Collett B, Ventafridda V, Cohen R, Gallacher D. Survey of chronic pain in Europe: prevalence, impact on daily life, and treatment. *European Journal of Pain*. 2006 May;10(4):287-333.
62. Yu HY, Tang FI, Kuo BI, Yu S. Prevalence, interference, and risk factors for chronic pain among Taiwanese community older people. *Pain Management Nursing*. 2006 Mar;7(1):2-11.
63. Nakamura M, Nishiwaki Y, Ushida T, Toyama Y. Prevalence and characteristics of chronic musculoskeletal pain in Japan. *Journal of orthopaedic science*. 2011 Jul;16(4):424-32.

64. Jakobsson U. The epidemiology of chronic pain in a general population: results of a survey in southern Sweden. *Scandinavian Journal of Rheumatology*. 2010;39(5):421-9.
65. Gallup-Healthways Well Being, Index. Chronic pain rates shoot up until Americans reach late 50's. [September 2012]; Available from: <http://www.gallup.com/poll/154169/chronic-pain-rates-shoot-until-americans-reach-late-50s.aspx>.
66. Smith BH, Elliott AM, Chambers WA, Smith WC, Hannaford PC, Penny K. The impact of chronic pain in the community. *Family Practice*. 2001 Jun;18(3):292-9.
67. Papageorgiou AC, Silman AJ, Macfarlane GJ. Chronic widespread pain in the population: a seven year follow up study. *Annals of the Rheumatic Diseases*. 2002 Dec;61(12):1071-4.
68. Berkley K. Sex differences in pain. *Behavioural and brain sciences*. 1997;20:371-80.
69. Pain clinical updates. Gender, pain and the brain: International Association for the Study of Pain 2008.
70. Paulson PE, Minoshima S, Morrow TJ, Casey KL. Gender differences in pain perception and patterns of cerebral activation during noxious heat stimulation in humans. *Pain*. 1998 May;76(1-2):223-9.
71. Derbyshire SW, Nichols TE, Firestone L, Townsend DW, Jones AK. Gender differences in patterns of cerebral activation during equal experience of painful laser stimulation. *Journal of Pain*. 2002 Oct;3(5):401-11.
72. Moulton EA, Keaser ML, Gullapalli RP, Maitra R, Greenspan JD. Sex differences in the cerebral BOLD signal response to painful heat stimuli. *American Journal of Physiology - Regulatory, Integrative and Comparative Physiology*. 2006 Aug;291(2):R257-67.
73. Zubieta JK, Smith YR, Bueller JA, Xu Y, Kilbourn MR, Jewett DM, et al. mu-opioid receptor-mediated antinociceptive responses differ in men and women. *Journal of Neuroscience*. 2002 Jun 15;22(12):5100-7.
74. Smith YR, Stohler CS, Nichols TE, Bueller JA, Koeppe RA, Zubieta JK. Pronociceptive and antinociceptive effects of estradiol through endogenous opioid neurotransmission in women. *Journal of Neuroscience*. 2006 May 24;26(21):5777-85.

75. Moulin DE, Clark AJ, Speechley M, Morley-Forster PK. Chronic pain in Canada- prevalence, treatment, impact and the role of opioid analgesia. *Pain Research and Management*. 2002 Winter;7(4):179-84.
76. Perquin CW, Hazebroek-Kampschreur AA, Hunfeld JA, Bohnen AM, van Suijlekom-Smit LW, Passchier J, et al. Pain in children and adolescents: a common experience. *Pain*. 2000 Jul;87(1):51-8.
77. Palermo TM. Assessment of chronic pain in children: current status and emerging topics. *Pain Research and Management*. 2009 Jan-Feb;14(1):21-6.
78. Fearon P, Hotopf M. Relation between headache in childhood and physical and psychiatric symptoms in adulthood: national birth cohort study. *British Medical Journal*. 2001 May 12;322(7295):1145.
79. United States Institute of Medicine. *Relieving Pain in America: A Blueprint for Transforming Prevention, Care, Education, and Research*. Washington DC 2011.
80. Chronic pain in America is a national disgrace. [2012 March]; Available from: <http://www.paintopics.org>.
81. Raftery MN, Ryan P, Normand C, Murphy AW, de la Harpe D, McGuire BE. The economic cost of chronic noncancer pain in Ireland: results from the PRIME study, part 2. *Journal of Pain*. 2012 Feb;13(2):139-45.
82. du Plessis P, Frohlich E. Chronic pain management in a South African government hospital: the lessons we have learnt. *World Interventional Pain Congress*; New York 2009.
83. Joint United Nations Programme on HIV/AIDS. *UNAIDS report on the global AIDS epidemic*. 2010 [June 2012]; Available from: <http://www.unaids.org/globalreport/>.
84. Stephenson J. Experts say AIDS pain 'dramatically undertreated'. *Journal of American Medical Association*. 1996 Nov 6;276(17):1369-70.
85. Marcus KS, Kerns RD, Rosenfeld B, Breitbart W. HIV/AIDS-related pain as a chronic pain condition: implications of a biopsychosocial model for comprehensive assessment and effective management. *Pain Medicine*. 2000 Sep;1(3):260-73.
86. Daut R, Cleeland C, Flanery R. Development of the Wisconsin Brief Pain Questionnaire to assess pain in cancer and other diseases. *Pain*. 1983;17(2):197-210.
87. Melzack R. The McGill Pain Questionnaire: major properties and scoring methods. *Pain*. 1975;1(3):277-99.

88. Breivik H, Borchgrevink P, Allen S, Rosseland L, Romundstad L, Breivik Hals E, et al. Assessment of pain. *British Journal of Anaesthesia*. 2008;101(1):17-24.
89. Shaikh A, Bentley A, Kamerman P. Symptomatology of Peripheral Neuropathy in an African Language. *Public Library of Science*. 2013;8(5).
90. Medical Protection Society. Why keep clinical records. [May 2013]; Available from: <http://www.medicalprotection.org/uk/booklets/medical-records/why-keep-clinical-records>.
91. Pullen I, Loudon J. Improving standards in clinical record-keeping. *Advances in Psychiatric Treatment*. 2006;12:280-6.
92. Raff M, James M. An audit of anaesthetic record keeping. *South African Journal of Anaesthesia and Analgesia*. 2003 July:7-9.
93. Royal College of Physicians. Generic multidisciplinary clinical record keeping standards: audit tool. [2013 May]; Available from: <http://www.rcplondon.ac.uk/resources/generic-multi-disciplinary-clinical-record-keeping-standards-audit-tool>.
94. Hoffmann S, Podgurski A. Finding a cure: The case for regulation and oversight of electronic health record systems. *Harvard Journal of Law and Technology*. 2008;22(Number 1 Fall):104-38.
95. Frellick M. New biometric device aims to improve record-keeping and security. *Hospitals & Health Networks*. 2013 March;57(3):18.
96. National Institute for Clinical Excellence. Principles for Best Practice in Clinical Audit. United Kingdom 2002 [June 2012]; Available from: <http://www.nice.org.uk/media/796/23/BestPracticeClinicalAudit.pdf>.
97. Turk et al. Core outcome domains for chronic pain clinical trials: IMMPACT recommendations. *Pain*. 2003, Dec.;106(3):337-45.
98. Kumar R. *Research methodology: A step-by step guide for beginners*. Second ed: Sage; 2005.
99. Burns N, Grove S. *The practice of nursing research*. 6th ed. Saunders, editor 2009.

## **Appendix I – Declaration of Montreal**

### **Declaration that Access to Pain Management Is a Fundamental Human Right**

*We, as delegates to the International Pain Summit (IPS) of the International Association for the Study of Pain (IASP) (comprising IASP representatives from Chapters in 64 countries plus members in 129 countries, as well as members of the community), have given in-depth attention to the unrelieved pain in the world,*

### **Finding that pain management is inadequate in most of the world because:**

- There is inadequate access to treatment for acute pain caused by trauma, disease, and terminal illness and failure to recognize that chronic pain is a serious chronic health problem requiring access to management akin to other chronic diseases such as diabetes or chronic heart disease.
- There are major deficits in knowledge of health care professionals regarding the mechanisms and management of pain.
- Chronic pain with or without diagnosis is highly stigmatized.
- Most countries have no national policy at all or very inadequate policies regarding the management of pain as a health problem, including an inadequate level of research and education.
- Pain Medicine is not recognised as a distinct specialty with a unique body of knowledge and defined scope of practice founded on research and comprehensive training programs.
- The World Health Organization (WHO) estimates that 5 billion people live in countries with low or no access to controlled medicines and have no or insufficient access to treatment for moderate to severe pain.
- There are severe restrictions on the availability of opioids and other essential medications, critical to the management of pain. **And, recognizing the intrinsic dignity of all persons and that withholding of pain treatment is profoundly wrong, leading to unnecessary suffering which is harmful; we declare that the following human rights must be recognized throughout the world:** *Article 1.* The right of all people to have access to pain management without discrimination (Footnotes 1-4). *Article 2.*

The right of people in pain to acknowledgment of their pain and to be informed about how it can be assessed and managed (Footnote 5). *Article 3.* The right of all people with pain to have access to appropriate assessment and treatment of the pain by adequately trained health care professionals (Footnotes 6-8). **In order to assure these rights, we recognize the following obligations:** 1. The obligation of governments and all health care institutions, within the scope of the legal limits of their authority and taking into account the health care resources reasonably available, to establish laws, policies, and systems that will help to promote, and will certainly not inhibit, the access of people in pain to fully adequate pain management. Failure to establish such laws, policies, and systems is unethical and a breach of the human rights of people harmed as a result. 2. The obligation of all health care professionals in a treatment relationship with a patient, within the scope of the legal limits of their professional practice and taking into account the treatment resources reasonably available, to offer to a patient in pain the management that would be offered by a reasonably careful and competent health care professional in that field of practice. Failure to offer such management is a breach of the patient's human rights. *Note:* This Declaration has been prepared having due regard to current general circumstances and modes of health care delivery in the developed and developing world. Nevertheless, it is the responsibility of: governments, of those involved at every level of health care administration, and of health professionals to update the modes of implementation of the Articles of this Declaration as new frameworks for pain management are developed.

---

## Footnotes

1. This includes, but is not limited to, discrimination on the basis of age, sex, gender, medical diagnosis, race or ethnicity, religion, culture, marital, civil or socioeconomic status, sexual orientation, and political or other opinion.

2. International Covenant on Economic, Social and Cultural Rights (ICESCR) (1966). The State parties of the ICESCR recognize “the right of everyone to the highest attainable standard of physical and mental health” (Art. 12), creating the “conditions which would assure to all medical service and medical attention in the event of sickness.”

3. Universal Declaration of Human Rights (1948): Rights to Health (Article 25); Convention on the Rights of a Child (Article 24); Convention on the Elimination of All Forms of



Discrimination Against Women (Article 12); Convention on the Elimination of All Forms of Racial Discrimination (Article 5(e) (iv)).

4. The Committee on Economic, Social and Cultural Rights. General Comment No.14, 22nd Session, April-May 2000 E/C 12/2000/4. “Core obligations” of all signatory nations included an obligation to ensure access to health facilities, goods, and services without discrimination, to provide essential drugs as defined by WHO, and to adopt and implement a national health strategy.

5. Committee on Economic, Social and Cultural Rights. General Comment No.14, 22nd Session, April-May 2000, E/C 12/2000/4, para. 12. General Comment No. 14 stated that health accessibility “includes the right to seek, receive and impart information and ideas concerning health issues.”

6. Appropriate assessment includes recording the results of assessment (e.g., pain as the “5th vital sign,” can focus attention on unrelieved pain, triggering appropriate treatment interventions and adjustments). Appropriate treatment includes access to pain medications, including opioids and other essential medications for pain, and best-practice interdisciplinary and integrative nonpharmacological therapies, with access to professionals skilled in the safe and effective use of these medicines and treatments and supported by health policies, legal frameworks, and procedures to assure such access and prevent inappropriate use. Given the lack of adequately trained health professionals, this will require providing educational programs regarding pain assessment and treatment in all of the health care professions and programs within the community for community care workers delivering pain care. It also includes establishment of programs in pain medicine for the education of specialist physicians in pain medicine and palliative medicine. Accreditation policies to assure appropriate standards of training and care should also be established.

7. Failure to provide access to pain management violates the United Nations 1961 Single Convention on Narcotic Drugs declaring the medical use of narcotic drugs indispensable for the relief of pain and mandating adequate provision of narcotic drugs for medical use.

8. The UN Universal Declaration of Human Rights (1948) (Article 5) states: “No one shall be subjected to torture or to cruel, inhuman or degrading treatment...” Comment: Deliberately ignoring a patient’s need for pain management or failing to call for specialized help if unable to achieve pain relief may represent a violation of Article 5.

9. The UN Special Rapporteur on the Right to Health and the UN Special Rapporteur on the

question of torture and other cruel, inhuman, and degrading treatment stated: “The failure to ensure access to controlled medicines for the relief of pain and suffering threatens fundamental rights to health and to protection against cruel, inhuman and degrading treatment.”

## Appendix II – Approval from Postgraduate Committee



Faculty of Health Sciences  
Private Bag 3 Wits, 2050  
Fax: 027117172119  
Tel: 02711 7172040

Reference: Ms Thokozile Nhlapo  
E-mail: [thokozile.nhlapo@wits.ac.za](mailto:thokozile.nhlapo@wits.ac.za)

Dr YMS Mayat  
53 Devon Terrace  
Westville  
3630  
South Africa

07 January 2014  
Person No: 701423  
PAG

Dear Dr Mayat

### **Master of Medicine: Approval of Title**

We have pleasure in advising that your proposal entitled *The profile of chronic pain patients attending the Helen Joseph Hospital Pain Management Unit* has been approved. Please note that any amendments to this title have to be endorsed by the Faculty's higher degrees committee and formally approved.

Yours sincerely

A handwritten signature in cursive script, appearing to read 'S Benn', with a horizontal line underneath.

Mrs Sandra Benn  
Faculty Registrar  
Faculty of Health Sciences

# Appendix III – Approval from the Human Research Ethics Committee (Medical) of the University of the Witwatersrand



**UNIVERSITY OF THE WITWATERSRAND, JOHANNESBURG**  
Division of the Deputy Registrar (Research)

**HUMAN RESEARCH ETHICS COMMITTEE (MEDICAL)**  
R14/49 Dr Yasmin MS Mayat

<b><u>CLEARANCE CERTIFICATE</u></b>	<b>MI20736</b>
<b><u>PROJECT</u></b>	The Profile of Chronic Pain Patients Attending the Helen Joseph Hospital Pain Management Unit
<b><u>INVESTIGATORS</u></b>	Dr Yasmin MS Mayat.
<b><u>DEPARTMENT</u></b>	Department of Anaesthesiology
<b><u>DATE CONSIDERED</u></b>	27/07/2012
<b><u>DECISION OF THE COMMITTEE*</u></b>	Approved unconditionally

**Unless otherwise specified this ethical clearance is valid for 5 years and may be renewed upon application.**

**DATE** 27/07/2012

**CHAIRPERSON**   
(Professor PE Cleaton-Jones)

\*Guidelines for written 'informed consent' attached where applicable  
cc: Supervisor : Ms Helen Perrie

**DECLARATION OF INVESTIGATOR(S)**

To be completed in duplicate and **ONE COPY** returned to the Secretary at Room 10004, 10th Floor, Senate House, University.

I/We fully understand the conditions under which I am/we are authorized to carry out the abovementioned research and I/we guarantee to ensure compliance with these conditions. Should any departure to be contemplated from the research procedure as approved I/we undertake to resubmit the protocol to the Committee. **I agree to a completion of a yearly progress report.**

*PLEASE QUOTE THE PROTOCOL NUMBER IN ALL ENQUIRIES...*

## **Appendix IV – Letter to CEO of Helen Joseph Hospital requesting permission to conduct the study and response**

Helen Joseph Hospital  
Private Bag X47  
Auckland Park  
Johannesburg  
2006

June 2012

Chief Executive Officer  
Helen Joseph Hospital

Attention: Ms. Bogoshi

### **RE: PERMISSION TO CONDUCT RESEARCH AT HELEN JOSEPH HOSPITAL**

Dear Ms. Bogoshi

I am a second year registrar in the Department of Anaesthesiology, currently working at Helen Joseph Hospital. I am also registered for a Master of Medicine (Anaesthesiology) degree at the Faculty of Health Sciences, University of the Witwatersrand. As part of the course requirement, I am expected to conduct clinical research under supervision. The title of my proposed research is “The profile of chronic pain patients attending the Helen Joseph Hospital Pain Management Unit.”

Helen Joseph Hospital has one of the biggest pain units in the country, and with your permission, I would like to collect the following data:

- number of pre-existing and new patients consulted in 2011
- demographic profile of patients attending the HJHPMU (age and gender)
- presenting complaint of patients
- diagnosis
- relevant medical history
- relevant surgical history

- type of pain.
- adequacy of record keeping.

The HJHPMU database for 2011 which contains schedules of appointments and procedures will be used. Other necessary data will be collected from the patients' files. The patient's privacy will at all times be protected. I will obtain permission from Professor Frohlich, the Head of Anaesthesiology and the Pain Management Unit at Helen Joseph Hospital.

I hereby apply for permission to carry out research at Helen Joseph Hospital. The proposed study and its procedures have been approved by the Ethics Committee and the Postgraduate Committee of the University of the Witwatersrand, the clearance certificate number is M120736.

There will be no financial implications for Helen Joseph Hospital, the Gauteng Provincial Department of Health or the University of the Witwatersrand. All costs related to administration and stationary will be covered by me. A copy of the final report will be made available to you should you request this.

Should you require any additional information, please contact me on 072 437 5059.

Yours Faithfully

---

Dr YMS Mayat  
MBCHB (UFS), DA (SA)  
Registrar in the Department of Anaesthesiology  
University of the Witwatersrand



**health and  
social development**  
Department: Health and Social Development  
GAUTENG PROVINCE

**Umyango Wezwmpilo no Kuthuthukiswa Komphakathi  
Lefapha La Maphelo le Tshebeletso le Ntshetsopele ya Sechaba  
Department of Health and Social Development  
Departemente van Gesondheid en Maatslike Ontwikkelig**

---

**Enquiries: Dr NL Hlongwane**

**Tel: 011 489 1070**

**Fax: 011 489 0841**

**Email: [Nombango.Hlongwane@gauteng.gov.za](mailto:Nombango.Hlongwane@gauteng.gov.za)**

**Dr YMS Mayat**

Registrar

Department of Anesthesiology

**REQUEST TO CONDUCT RESEARCH TITLE:**

**THE PROFILE OF CHRONIC PAIN PATIENTS ATTENDING THE HELN JOSEPH  
HOSPITAL PAIN MANAGEMNET UNIT**

Please note that your above request is provisionally approved. Your study can only commence once ethics approval is obtained.

Yours sincerely,

.....  
**Dr NL Hlongwane**  
**Senior Medical Superintendent**

---

**Helen Joseph Hospital**  
Perth Road  
Tel: 011 489 1011

**Private Bag X47**  
**Auckland Park**  
**2006**

## **Appendix V – Letter to head of Helen Joseph Hospital Pain Management Unit**

Helen Joseph Hospital  
Private Bag X47  
Auckland Park  
Johannesburg  
2006

June 2012

### **RE: PERMISSION TO ACCESS HELEN JOSEPH HOSPITAL'S PAIN MANAGEMENT UNIT'S DATABASE AND PATIENT FILES**

Dear Professor Frohlich

I am conducting a study on chronic pain that the Helen Joseph Hospital Pain Management Unit expressed a need for. I will be describing the profile of chronic pain patients attending this unit from January 2011 to December 2011 and assessing the adequacy of record keeping.

The primary objectives of this study are to determine the:

- number of pre-existing and new patients consulted in 2011
- demographic profile of patients attending the HJHPMU (age and gender)
- presenting complaint of patients
- diagnosis
- relevant medical history
- relevant surgical history
- type of pain.

The secondary objective of this study is to determine the adequacy of record keeping.

I would like to request access to the Pain Management Unit's database and patients files for 2011. Your support in this matter will be much appreciated.

Yours Faithfully

-----

Dr YMS Mayat  
MBChB(UFS) DA(SA)

Registrar in the Department of Anaesthesiology, University of the Witwatersrand



## Appendix VI – Data collection sheet

Study number

New Patient

Known patient

Age

Male

Female

Peripheral Neuropathy

CRPS

Myofascial pain syndrome

Other

Relevant medical history

Relevant surgical history

Type of pain

# Appendix VII - Helen Joseph Hospital Pain Management

## Unit pain questionnaire



Anaesthetic department and  
Pain management unit  
Helen-Joseph and Coronation Hospitals  
Private Bag x47  
2006 Auckland Park  
JOHANNESBURG

Phone: 011-489-0462  
Fax: 011-489-0462  
E-mail: frohliche@medicine.wits.ac.za

## PAIN ASSESSMENT FORM

### Patient details

Name \_\_\_\_\_ Hospital no \_\_\_\_\_  
Patient classification- \_\_\_\_\_ Medical aid name and no. \_\_\_\_\_  
Contact details -Tel no \_\_\_\_\_ Address \_\_\_\_\_  
Is this visit related to a WCA claim? \_\_\_\_\_

Referred by- \_\_\_\_\_  
Name and contact details of the treating GP \_\_\_\_\_

### Pain history

#### Main complaint

---

---

---

When started \_\_\_\_\_  
How pain started (accident, surgery, illness, other) \_\_\_\_\_  
Is pain always present? Same intensity? \_\_\_\_\_  
What makes pain worse? (sitting, standing, lifting, lying down, bending, , noise, weather, work, stress, sex, driving ,other.) \_\_\_\_\_  
What makes pain better? \_\_\_\_\_  
Character of pain- (shooting,pricking,stabbing,sharp,pressing, burning, itchy, tingling, dull, sickening, ) \_\_\_\_\_  
Worst Pain in last 24h \_\_\_\_\_ Best Pain in last 24h \_\_\_\_\_ Pain now \_\_\_\_\_

Pain medication used now- \_\_\_\_\_  
(include herbal, traditional, vitamins, creams, gels, drugs, alcohol.) \_\_\_\_\_

---

% Relief with medication-  
Activity -Socializing  
Mood -Work

---

Pain medication taken in the past

Do you need more / stronger medication? Yes / No

Have you ever had-

Cancer, lung disease, heart disease, High BP, Low BP, kidney, joint or bone disease, Diabetes, Thyroid disease?

Ever had radiation or chemotherapy?

Smoking

Alcohol

### **Medical history**

-CNS \_\_\_\_\_

-CVS \_\_\_\_\_

-Respiratory \_\_\_\_\_

-Endocrine \_\_\_\_\_

-GIT \_\_\_\_\_

- Urogenital \_\_\_\_\_

-Habits / Allergies

### **Surgical history**

## **Other medication**

**What is your expectation for the coming months concerning your pain?**

**pain will be reduced by**

**25%, 50%, 75%, 100% , no change**

**Do you think your pain is due to a serious disease your doctors have not found or have not told you about?**

Please indicate where your pain is. Shade any area to which pain might spread.

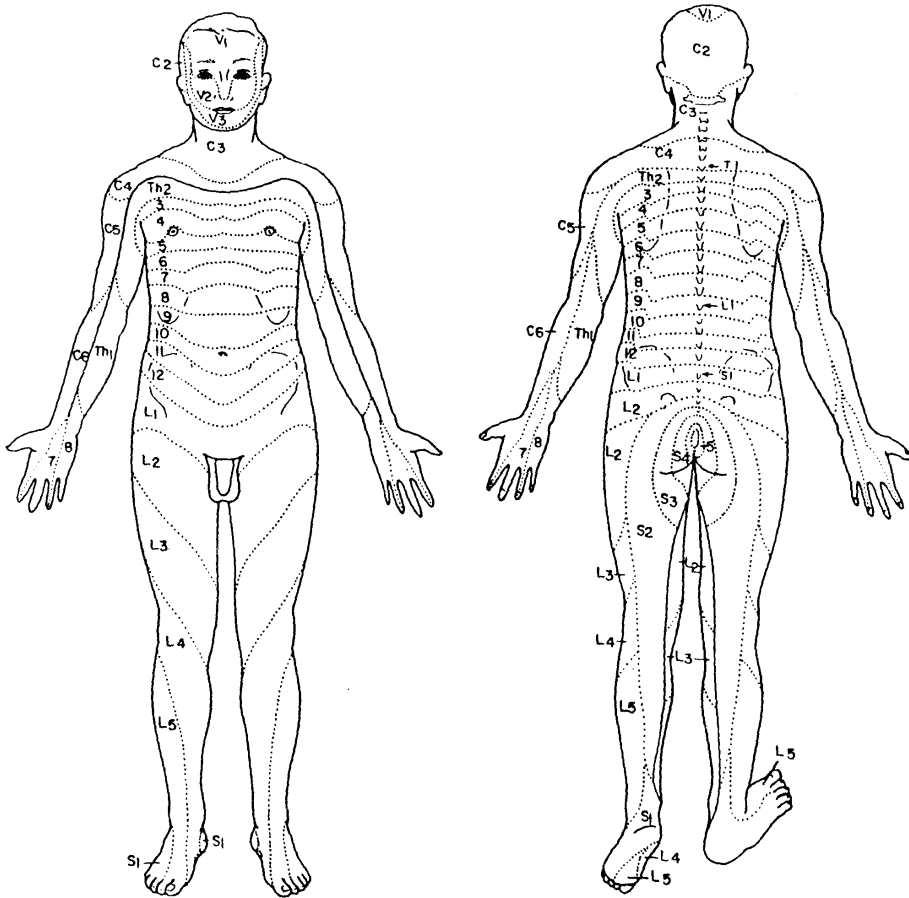
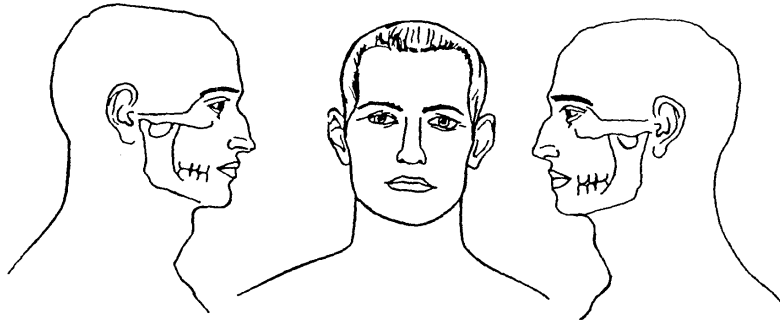

## **Examination**

Height          Weight                  BP                  PR

Skin- (scars, TP, Tender points, Allodynia, Hyperalgesia, Autonomic NS.)

### **Pain behaviour**

#### **CRANIAL NERVES**                  **R**                  **L**

II (Optic)-visual acuity and fields

III (Oculomotor) Extraocular muscles

IV (Trochlear) Pupillary constriction

Cervical sympathetic- Pupillary dilatation

V (Trigeminal) sensation face,ant 2/3 scalp,corneal reflexes,Maseters

VII (Facial)

VIII (Auditory)-

IX (Glossopharyngeal) Gag/swallow

X (Vagus) Gag/ Swallow

XI (Accessory) Shrug/Head rotation

XII (Hypoglossal)-Toungue movement

#### **HEAD AND NECK**                  **R**                  **L**

Inspection

Palpation

Mobility (**Head Flexion,extension,Side,Rotation**)

#### **TORSO**                  **Back**                  **Front**

Inspection (Kyphosis / Scoliosis Symmetry,Scars)

Palpation (Tenderness)

ROM          (Bend forward, Bend backwards ,Sideways, Rotation)

Waddel \_\_\_\_ (weight, rotation)

#### **UPER EXTREMITY**                  **R**                  **L**

Muscle bulk

Power

Autonomic

ROM

Pulses

Reflexes

Sensation

#### **LOWER EXTREMITY**                  **R**                  **L**

Power

Muscle bulk

Autonomic

Reflexes

Sensation

Pulses

**Sciatica**

## **General examination**

CNS-  
CVS  
RESPIRATORY  
ENDOCRINE  
GIT  
UROGENITAL

## **SOCIAL HISTORY**

Marital status  
Children and their ages  
Who do you live with  
Level of education completed

## **EMPLOYMENT HISTORY**

Occupation before injury/pain

Occupation now

( Work status (full time, casual, part time etc)

Is pain a reason for work limitation? (How much time did you take off work due to pain in the last year)

Current source of income (salary, savings, pension )

List all doctors /specialists/alternative practitioners you have seen for treatment of pain

1. 2.
3. 4.

List all investigations and X- ray/Scanning you have had for your pain

## **Final Diagnosis**

## **Management**

Date

Rx

---

---

---

---

---

---

---

VISIT NO Date	1	2	3	4	5	6	7	8	9
VAS Av.24h									

## Appendix VIII – Recommended data collection sheet

Name: \_\_\_\_\_

Hospital Number: \_\_\_\_\_

Age: \_\_\_\_\_

Date of first: \_\_\_\_\_

**Gender :**

Male

Female

**Employed:**

Yes

No

**Race:**

Black

Coloured

Indian

White

Other

**History of psychiatric diagnoses:**

Yes

No

**Type of pain:**

Nociceptive

Neuropathic

Mixed

**NSAID Abuse:**

Yes

No

**Cause of pain:**

Cancer

Post traumatic

Post surgical

Medical

MVA/PVA

**Diagnosis:**

Spinal pain

FBSS

CRPS

Arthritis

Peripheral neuropathy