

A Study of Newly Discovered Lithics from Earlier Stone
Age deposits at Sterkfontein, Gauteng Province, South
Africa.

Dominic Justin Stratford

Student No. 0617421K

A dissertation submitted to the School of Geography,
Archaeology and Environmental Studies, Faculty of Science
University of the Witwatersrand, Johannesburg for the degree of Master of
Science.

Johannesburg 2008

Declaration

I, Dominic Justin Stratford, hereby declare that this thesis is my own work and has not been submitted for a Master's Degree at any other University.

Acknowledgments

The writer would like to extend many thanks to Dr. Kathy Kuman for her excellent guidance and wisdom through this research and all my interests. I would also like to thank Prof. Clarke for his support, advice and unerring enthusiasm for the Sterkfontein caves and the projects within. I would like to express my gratitude to Dr. Laurent Bruxelles for his help interpreting the stratigraphy of the Name Chamber and mapping the stratigraphic sections. I would also like to thank the Palaeontological Scientific Trust and the National Research Foundation for their financial support, which allowed me to conduct this research. My thanks also go to my family, my father and mother for their constant support over the years and their never-ending patience. My gratitude is also extended to the University of the Witwatersrand for support both financial and administrative. Finally I would like to thank the Sterkfontein site technicians and my colleagues for their willingness to excavate in such difficult conditions and always being happy to help.

Abstract

The need to expand the current lithic Plio-Pleistocene assemblages at Sterkfontein and to understand how these assemblages have been incorporated into the cave deposits is of key importance to archaeological research on the Oldowan and Early Acheulean of South Africa. The greater the archaeological sample size the more accurately inferences can be made regarding the behaviour and technological practices of local hominid groups. An accurate understanding of depositional processes influencing these assemblages allows inferences to be made regarding the post-depositional movement of elements within the assemblage.

The first objective of this research is to expand the assemblages representing the earliest stone tool technologies found at Sterkfontein. The first assemblage researched here is the Dump 21 collection, a small number of artefacts found recently just south of the Sterkfontein Member 5 West breccia and the former Extension Site of John Robinson. This material had been removed from a cave deposit by lime miners and dumped where it was found. This dump may have been created up to a century ago and was concealed by vegetation. The technological attributes exhibited on the cores and flakes of Dump 21 were compared to the current Sterkfontein Early Acheulean of Member 5 West. Parallel patterns in core types and flaking patterns, as well as raw material utilisation, suggest analogous technological intention and therefore identical depositional origins.

The second assemblage analysed here was excavated from the Name Chamber and yielded large quantities of quartz dominated small flaking debris. Comparisons of raw material profiles and technological attributes of artefacts <20mm in size indicate the Name Chamber artefacts originated within the Oldowan assemblage, with a large proportion of <10mm and some <20mm material being winnowed out of the Member 5 East Oldowan breccia at some stage.

The second objective of this research was to more clearly understand the processes involved in the formation of the Name Chamber deposit, examination of the geology and stratigraphy of the Name Chamber was undertaken. Three depositional events have been isolated. The first deposit filled the existing Sterkfontein chambers prior to the opening of the caves to the surface. The second and third deposits have entered the Name Chamber through a shaft that appears to articulate with the deepest portions of the Member 5 East area of the site, forming fauna-rich talus slopes within the chamber. The changing internal structure of this shaft has influenced the size profile and destination of the sediments accumulated in the three current talus deposits fed by the shaft.

Contents

<u>Chapter 1. Introduction</u>	1
<u>Chapter 2. Literature Review</u>	3
2.1. Sterkfontein Archaeology	3
2.2. Sterkfontein Site Formation and Stratigraphy	4
2.2.1. Previous Theory	4
2.2.2. Current Theory	9
2.2.3. Previous Name Chamber stratigraphy and formation	13
2.3. Previous and Current Theory of Lithic Analysis	23
<u>Chapter 3. Methodology</u>	30
3.1. Current Sterkfontein Assemblages	30
3.2. Excavation Methodology	35
3.3. Lithic Analysis Methodology	40
3.3.1 Standard lithic measurements	41
3.3.2. Lithic assemblage definitions and interpretations	44
<u>Chapter 4. Dump 21 Analysis and Results</u>	49
4.1. Assemblage Overview	50
4.2. Raw Material Use and Selection	52
4.3. Typology	53
4.3.1. Dump 21 Core Types	54
4.3.2. Dump 21 Flake Types	58
4.4. Core Reduction and Flaking Patterns	59
4.4.1. Cores	59

4.4.2. Flakes	68
4.5. The Dump 21 Handaxe	70
4.6. Artefact Condition	71
4.7. Dump 21 Comparisons with Sterkfontein	
Early Acheulean	72
4.8. Dump 21 Conclusions and Discussion	78

Chapter 5. Name Chamber Stratigraphy
and Archaeology **86**

5.1. Name Chamber Stratigraphy and Site Formation	86
5.1.1. Geological description of the Name Chamber Deposits	87
5.1.2. Stratigraphic Conclusions	105
5.2. Name Chamber Archaeology	107
5.2.1. Assemblage Overview	108
5.2.2. Raw Material Use and Selection	111
5.2.3. Core Reduction and Flaking Patterns	114
5.2.4. Small Flaking Debris	124
5.2.5. Name Chamber Assemblage Conclusions and Comparisons	126

Chapter 6. Conclusions and Discussion **134**

6.1. Dump 21	134
6.2. Name Chamber	135

Bibliography **138**

<u>Appendix</u>	147
<u>Appendix A</u> - Sample of the Dump 21 Catalogue.	147
<u>Appendix B</u> - Name Chamber data by excavation.	148
Square A.	
Square B.	
Square C.	
Square D.	
Square E.	
Square F.	
Square G.	
Square H .	
Square I .	
Square J .	
Square K .	
Square L .	
Square M.	
Square N.	
Square O.	
Square P.	
Square Q.	
Square R.	
Lost Context.	
Lower Talus.	
Name Chamber complete assemblage.	

List of Figures

Figure 2.1. Cook's 1938 Sterkfontein Stratigraphy.	6
Figure 2.2. Robinson's 1962 Sterkfontein stratigraphy.	7
Figure 2.3. Wilkinson's 1983 Sterkfontein stratigraphy.	7
Figure 2.4. Partridge and Watt's 1991 Sterkfontein stratigraphy.	8
Figure 2.5. Clarke's 2006 Sterkfontein stratigraphy.	10
Figure 2.6. Schematic north-south section through talus cone on the Name Chamber.	14
Figure 2.7. Hypothetical reconstruction of the Extension Site cavern to show ingress of stony breccia with loosely calcified area at B.	16
Figure 2.8. Later Hypothetical stage to show collapse and infilling of the Extension Site cavern and Name Chamber beneath.	17
Figure 2.9. Sterkfontein main excavation.	19
Figure 2.10. East-west profile of the northern wall of the Member 5 breccia.	21
Figure 3.1. Sterkfontein Early Acheulean artefact weathering profiles.	34
Figure 3.2. Name Chamber excavation squares.	37
Figure 3.3. Key to excavation schematics.	38
Figure 3.4. Schematic of Name Chamber excavation 1.	38
Figure 3.5. Schematic of Name Chamber excavation 2.	38
Figure 3.6. Schematic of Name Chamber excavation 3.	39
Figure 3.7. Schematic of Name Chamber excavation 4.	39
Figure 4.1. Sterkfontein and lime worker's dumps.	51
Figure 4.2. Sterkfontein site including Dump 21 location.	51
Figure 4.3. Dump 21 core types.	57
Figure 4.4. Dump 21 artefact composition.	57
Figure 4.5. Remaining workable platforms on Dump 21 cores.	62
Figure 4.6. Number of step and hinge terminations on Dump 21 cores.	62
Figure 4.7. Proportion of Dump 21 cores with step or hinge termination flake scars.	63
Figure 4.8. Bell curve graph of flake scar size on Dump 21 cores.	63
Figure 4.9. Remaining cortex quantities on Dump 21 cores.	64

Figure 4.10. Mean flake scar number per remaining cortex value on Dump 21 cores.	64
Figure 4.11. Number of flake scars on Dump 21 multi-platform randomly flaked cores.	65
Figure 4.12. Number of flake scars on Dump 21 radially flaked cores.	66
Figure 4.13. Number of flake scars on Dump 21 casual cores.	67
Figure 4.14. Number of dorsal flake scars on Dump 21 flakes.	69
Figure 4.15. Dorsal flake scar size on Dump 21 flakes.	69
Figure 4.16. Weathering conditions of all Dump 21 artefacts.	72
Figure 4.17. Flake scar numbers on Sterkfontein Early Acheulean quartzite cores vs Dump 21 cores.	74
Figure 4.18. Mean maximum flake scar length of Sterkfontein Early Acheulean quartzite cores vs Dump 21 cores.	74
Figure 4.19. Mean remaining platforms for Sterkfontein Early Acheulean quartzite cores vs. Dump 21 cores.	75
Figure 4.20. Sterkfontein Early Acheulean quartzite core types.	75
Figure 4.21. D21 1000. Dump 21 radially flaked core	82
Figure 4.22. D21 1005. Dump 21 radially flaked core	83
Figure 4.23. D21 1164. Dump 21 radially flaked core	83
Figure 4.24. D21 1165. Dump 21 polyhedral core	84
Figure 4.25. D21 1174. Dump 21 casual core	84
Figure 4.26. D21 1175. Dump 21 polyhedral core	84
Figure 4.27. D21 1179. Dump 21 polyhedral core	85
Figure 4.28. D21 1006. Dump 21 unifacial handaxe	85
Figure 5.1. Remnant of the ancient brecciated infill.	88
Figure 5.2. Preserved profile of the old brecciated deposit on the far eastern wall of the Name Chamber.	90
Figure 5.3. Schematic of the younger ‘soft’ deposits currently filling the Name Chamber.	92
Figure 5.4. The Far Western Talus emerging from the Name Chamber into the Milner Hall.	94
Figure 5.5. Stratigraphy within the younger ‘soft’ deposit.	95
Figure 5.6. Geological section cut into the Western Talus.	97

Figure 5.7. Northern aspect. Image of the Western and Eastern talus converging below the 14m point.	98
Figure 5.8. Profile of the western wall of Excavation 1 (Ex1).	99
Figure 5.9. Northern aspect of the Eastern Talus from approximately 14m below the base of the feeding shaft.	102
Figure 5.10. The main Sterkfontein excavation with position of the Name Chamber feeding shaft opening into the Member 5 deposit.	104
Figure 5.11. Profile of the Western Talus including excavations.	106
Figure 5.12. Name Chamber artefact size category proportions.	110
Figure 5.13. Name Chamber artefact condition.	110
Figure 5.14. Name Chamber total artefact raw material proportions.	113
Figure 5.15. Name Chamber artefact raw material proportions through size category.	114
Figure 5.16. Name Chamber flake categories.	119
Figure 5.17. Name Chamber mean complete flake dimensions.	120
Figure 5.18. Name Chamber mean incomplete flake dimensions.	120
Figure 5.19. Name Chamber mean flake fragment dimensions.	121
Figure 5.20. Name Chamber flakes by raw material.	122
Figure 5.21. Name Chamber mean total flake dimensions.	123
Figure 5.22. Name Chamber number of dorsal scars on flakes by raw material.	123
Figure 5.23. Name Chamber number of dorsal scars by flake type.	124
Figure 5.24. Name Chamber raw material proportions for <20mm artefacts.	125
Figure 5.25. Name Chamber small flaking debris condition.	126
Figure 5.26. Oldowan versus Name Chamber raw material proportions for <20mm artefacts.	129
Figure 5.27. Oldowan versus Name Chamber total assemblage by size category.	130
Figure 5.28. Oldowan versus Name Chamber flake category proportions.	130
Figure 5.29. Oldowan versus Name Chamber artefact condition through size category.	131
Figure 5.30. Artefacts recovered by Robinson.	132

Figure 5.31. STK-NC 1.	132
Figure 5.32. Name Chamber flakes.	133

Tables

Table 2.1. Sullivan and Rozen's flake technological attribute key.	26
Table 3.1. Artefact types and raw materials for the Sterkfontein Oldowan assemblage.	30
Table 3.2. Experimental Vs Oldowan assemblage size profiles excluding cores, manuports, irregularly fractured cobbles and damaged pieces.	32
Table 3.3. Sterkfontein Early Acheulean assemblage composition.	34
Table 4.1. Artefact types and raw materials for the Dump 21 assemblage.	50
Table 4.2. Dump 21 artefact typologies.	54
Table 4.3. Details for the Dump 21 polyhedral cores.	55
Table 4.4. Details for the Dump 21 casually flaked cores.	56
Table 4.5. Details for the Dump 21 radially flaked cores.	56
Table 4.6. Details for the Dump 21 flakes.	58
Table 4.7. Details for the Dump 21 core rejuvenation flake.	59
Table 4.8. Artefact data for the Dump 21 core trimming flake.	59
Table 4.9. Attributes exhibited on Dump 21 multi-platform randomly flaked cores.	65
Table 4.10. Attributes exhibited on Dump 21 radially flaked cores.	66
Table 4.11. Attributes exhibited on Dump 21 casually and bifacially flaked cores.	67
Table 4.12. Attributes exhibited on all Dump 21 flakes.	68
Table 4.13. Attributes exhibited on the Dump 21 handaxe.	71
Table 4.14. Sterkfontein Early Acheulean general core data (taken from Sterkfontein Early Acheulean quartzite cores) versus Dump 21 general core data.	73
Table 4.15. Sterkfontein Early Acheulean casual and bifacial core data versus Dump 21 casual and bifacial core data.	73
Table 4.16. Sterkfontein Early Acheulean polyhedral core data versus Dump 21 polyhedral core data.	73

Table 4.17. Sterkfontein Early Acheulean discoidal core data versus Dump 21 discoidal core data.	73
Table 4.18. Assemblage profile of the combined Dump 21 collection and the Sterkfontein Early Acheulean.	83
Table 5.1. Artefact types and raw materials for the Name Chamber assemblage.	109
Table 5.2. Name Chamber assemblage size profile.	109
Table 5.3. Artefact data for the Name Chamber cores.	115
Table 5.4. Artefact data for the Name Chamber complete flakes.	118
Table 5.5. Artefact data for the Name Chamber incomplete flakes.	118
Table 5.6. Artefact data for the Name Chamber flake fragments.	119
Table 5.7. Artefact data for the total Name Chamber flakes.	122
Table 5.8. Sterkfontein Oldowan artefact type and raw material assemblage composition including the Name Chamber assemblage.	131

Chapter 1. Introduction

The site of Sterkfontein has been considered a palaeontological gem since the 1930's when the cave breccias revealed many ancient faunal remains, including the remains of many early hominids (Broom 1936; Broom 1950; Hughes and Tobias 1977; Clarke 1988; Clarke and Tobias 1995; Clarke 1999). Sterkfontein also represents one of a handful of sites in the world where Oldowan and Early Acheulean technology is found in association with faunal and hominid remains. Within the Sterkfontein caves there are deposits with stone tools from early hominid activities around the cave entrances. These tools represent the earliest cultural evidence for Oldowan tool-making hominids in southern Africa, as well as some of the oldest Early Acheulean assemblages.

A detailed analysis and expansion of the Earlier Stone Age assemblages will allow a better understanding of behavior and technological practices of these hominid species in South Africa. The Oldowan industry is the oldest of the hominid chipped stone tool technologies at nearly 2.6 Ma (Semaw 2000, Semaw et al. 2003). The Acheulean industry (1.8 – 0.3 Ma) represents the first stone tool technology to produce task-specific tool types (i.e. handaxes, cleavers). The difference in tool manufacture corresponds with the appearance of *Homo ergaster* (\pm 1.8 Ma) and represents different behavioural and land-use patterns. New dating techniques have for the first time been applied to the Sterkfontein members, allowing the assignment of more accurate dates. ESR (Electron Spin Resonance) dating and Palaeomagnetism dating have been applied to members two and four with results that confirm stratigraphic and faunal comparison analysis (Clarke 2002). Cosmogenic nuclide dating techniques have recently been successfully applied to an Oldowan quartz manuport by Granger and Gibbon (Kuman personal communication).

Chapter 2 reviews the literature relevant to the current Sterkfontein stratigraphy and archaeology. Chapter 3 presents the current Oldowan and Early Acheulean assemblages and discusses the methodology used to accurately conduct and interpret the data retrieved from Earlier Stone Age artefacts.

The research presented in this thesis addresses three issues that currently require clarification:

The first question is one of provenance. Dump 21 was recently found at some distance from the main Sterkfontein excavation. The goal of this aspect of the research was an examination of the artefacts found in this dump. Following this analysis, a

comparison with the technological attributes and proportions of its closest neighbour, the Member 5 West Early Acheulean, was carried out. The sample size is very small, but if successful correlations with the larger assemblage can be found, this will provide context for the new collection of artefacts and help expand this important assemblage. The analysis and interpretation of the Dump 21 collection is presented in Chapter 4.

The second question addressed in this research is that of stratigraphy. The formation, workings and content of the Name Chamber, one of Sterkfontein's central caverns, have been unclear since the beginning of work at Sterkfontein. Robinson found three artefacts within the upper walls of the chamber and was the first to offer a hypothesis of its formation (Robinson 1962). Clarke has presented a more detailed theory regarding its formation and relationship with the above Member 5 East Oldowan deposit. Chapter 5 presents an explicit analysis of the stratigraphy, morphology and depositional trends of the Name Chamber (Clarke 1994).

The third question is again one of provenance. Excavations within the Name Chamber talus have provided the first sampling of its contents and yielded over a thousand artefacts from the 'soft' surface layers. The analysis and comparison of this assemblage to the Member 5 East Sterkfontein Oldowan is of key importance in establishing a relationship between the Name Chamber and the Oldowan deposit, as theorized by Clarke (1994). The results of this analysis and comparison are presented in Chapter 5.

A summary of the conclusions and discussions from this research is presented in Chapter 6.

Chapter 2. Literature Review

2.1. Sterkfontein Archaeology

Previous Study

Discovery and recognition of Earlier Stone Age (ESA) artefacts in South Africa arose as early as the second decade of the Twentieth century. Péringuey's (1911) work *The Stone Ages of South Africa* clearly displays an awareness of the antiquity of the occupation of South Africa. The work of Goodwin (1926), Burkitt (1928), van Riet Lowe (1937, 1938) and L.S.B. Leakey (1936) laid the foundations for the focal work of Mason's *'Prehistory of the Transvaal'* (1962), which carried out the first dedicated analysis of the Sterkfontein stone-tool assemblage. Other early researchers systematised the findings of the stone artefacts at Sterkfontein, which were excavated and researched from sources of varying quality: from excavated breccia with good provenance to material from lime worker's dumps littering the site (Robinson 1957; Mason 1962; M.D. Leakey 1970; Stiles and Partridge 1979). Some of these researchers, while attempting to gauge the depth and intricacy of the African cultural antiquity, were influenced in part by the Europeanist classification of the Lower Palaeolithic. The discovery of artefacts of significant age was not difficult; Abbé Breuil once commented that there were not only enough specimens to fill a museum (on Canteen Kopje) to overflowing but to build it of them (Clark 1959: 127).

While Mason did not uncover an Oldowan industry at the Sterkfontein site during the 1960's, continued work has revealed a large Oldowan collection and has also expanded upon the previously known Early Acheulean technology in the Member 5 deposit (Kuman 1994a, b; Kuman 1996, 1998, 2003, 2007; Kuman and Clarke 2000; Kuman et al. 2005; Kuman and Field 2008; Kuman and Gibbon in press). The Member 5 East deposit overlies the Name chamber talus. Clarke (1994) has suggested that the Name Chamber talus represents one or more prior deposits associated with the infilling of Member 5 and the collapse of the earliest breccias including the StW53 Infill. A well-preserved Oldowan industry and two Early Acheulean assemblages in the Member 5 breccia have been identified (Kuman 1994b; Kuman and Clarke 2000). It is these two industries that could potentially be included in the Name Chamber talus and must be addressed in this study.

Also the Dump 21 artefacts must be compared with the characteristics of these two industries to determine its best affinity.

2.2. Sterkfontein Site Formation and Stratigraphy

2.2.1. Previous Theory

In 1938 the first stratigraphic evaluation was published on the excavated Sterkfontein cave breccias (See Figure 2.1; Clarke 2006). The bone-bearing deposits had been worked on for two years by Broom before Cooke's 1938 assessment (Broom 1936). Twenty years later, the stratigraphic works of Brain had not yet differentiated between the lower cave chamber breccia and the surface breccia, and Brain's assessment was that the Sterkfontein deposit was one continuous deposit (Brain 1958).

The discovery of stone artefacts within breccia at the western end of the Sterkfontein site by Robinson in 1956 led to the re-assessment of that area (Robinson 1957). After excavations yielded stone tools within the breccia and *in situ* it was suggested that due to the presence of stone tools in the western area but not in the more eastern excavations that this tool bearing breccia represented a different infill (Robinson 1957). Robinson further observed 3 types of breccia, each containing different faunal deposits. He identified a lower breccia (type site), a middle breccia (red-brown) and an upper breccia (chocolate brown) (Robinson 1962). Robinson's 1962 stratigraphic representation is shown in Figure 2.2.

Robinson still considered the lower breccia to stretch from their eastern surface exposure to the underground chambers in one large infill (Robinson 1962). Importantly, he observed the collapse of the middle breccia into a deeper large cavern now called the Name Chamber. Robinson collected three stone artefacts from the very top of the large talus deposit that fills the Name Chamber (Robinson 1962). The next significant work on the Sterkfontein breccias came from Partridge in 1978. Using the information gathered by Wilkinson in his geomorphic study of the cave system (Wilkinson 1973), Partridge carried out sedimentological examination of the breccias and provided an analysis of what he labelled the "Sterkfontein Formation" (Partridge 1978). This study was the first to re-interpret the breccias and Partridge re-named Robinson's Lower, Middle and Upper breccias Members 4, 5 and 6 from the surface excavation and identified members 1, 2 and

3 from the Silberberg Grotto (Partridge 1978). Wilkinson's 1983 stratigraphy is shown in Figure 2.3 and Partridge and Watt's (1991) stratigraphy is shown in Figure 2.4. Wilkinson believed that the lowest breccias of the Sterkfontein formation lay below what was named the Member 1 breccias and were evident in the lower chambers like the Jacovec Cavern (Wilkinson 1983). Partridge and Watt contested this theory and believed that the deposits within the Jacovec Cavern were not part of the identified Sterkfontein formation (Partridge and Watt 1991).

The stratigraphic representation of Partridge and Watt's (Figure 2.4) was the most comprehensive before Clarke started to work towards a deeper understanding of the inter-relations of the breccias. In the next section I have exhibited Clarke's latest stratigraphy and given an overview of the different members, how they have formed and how they inter-relate within the Sterkfontein cave system. For a more detailed account of this latest stratigraphy see Clarke (2006).

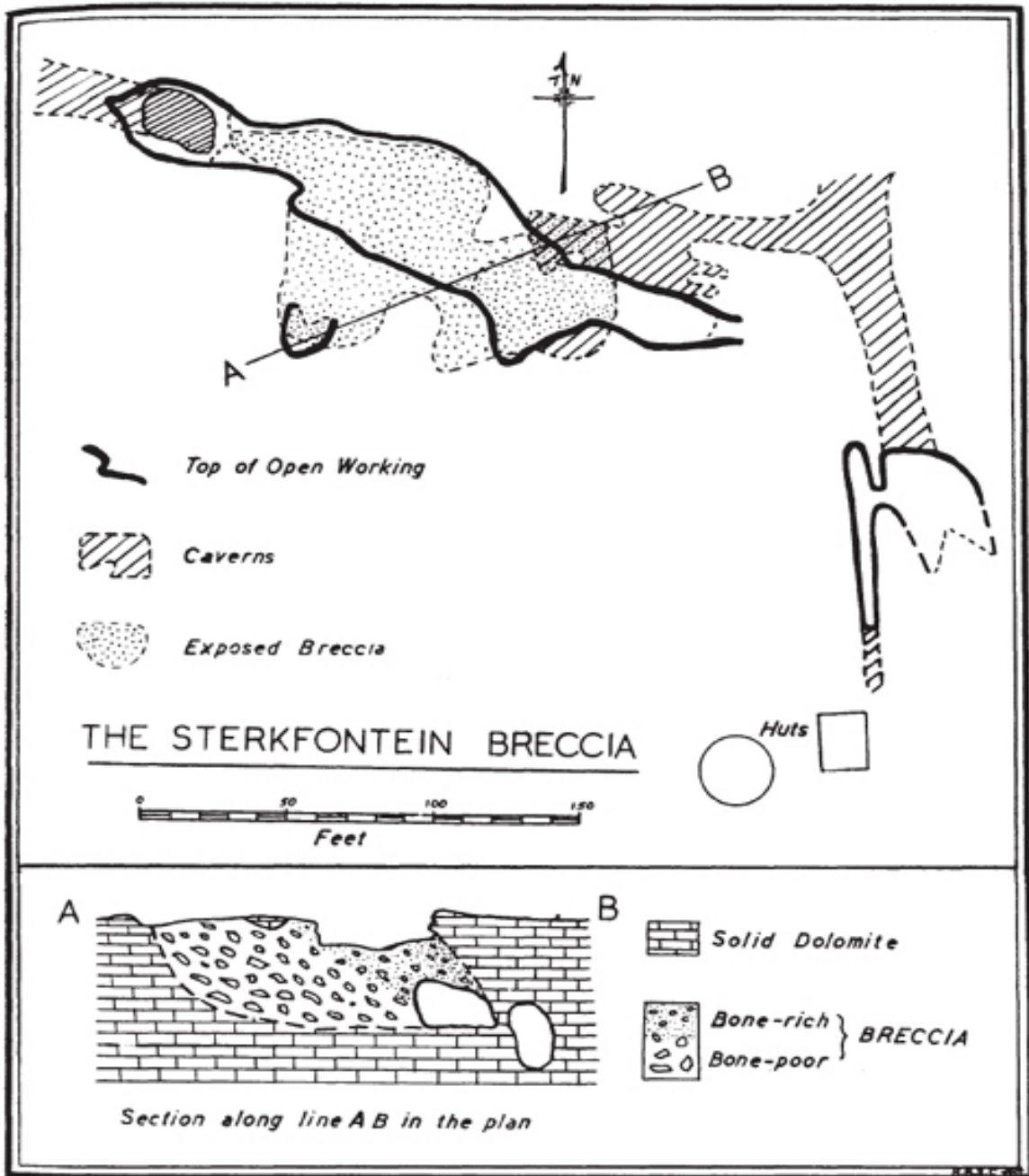

Figure 2.1. Cooke's 1938 Sterkfontein Stratigraphy (from Cooke 1938).

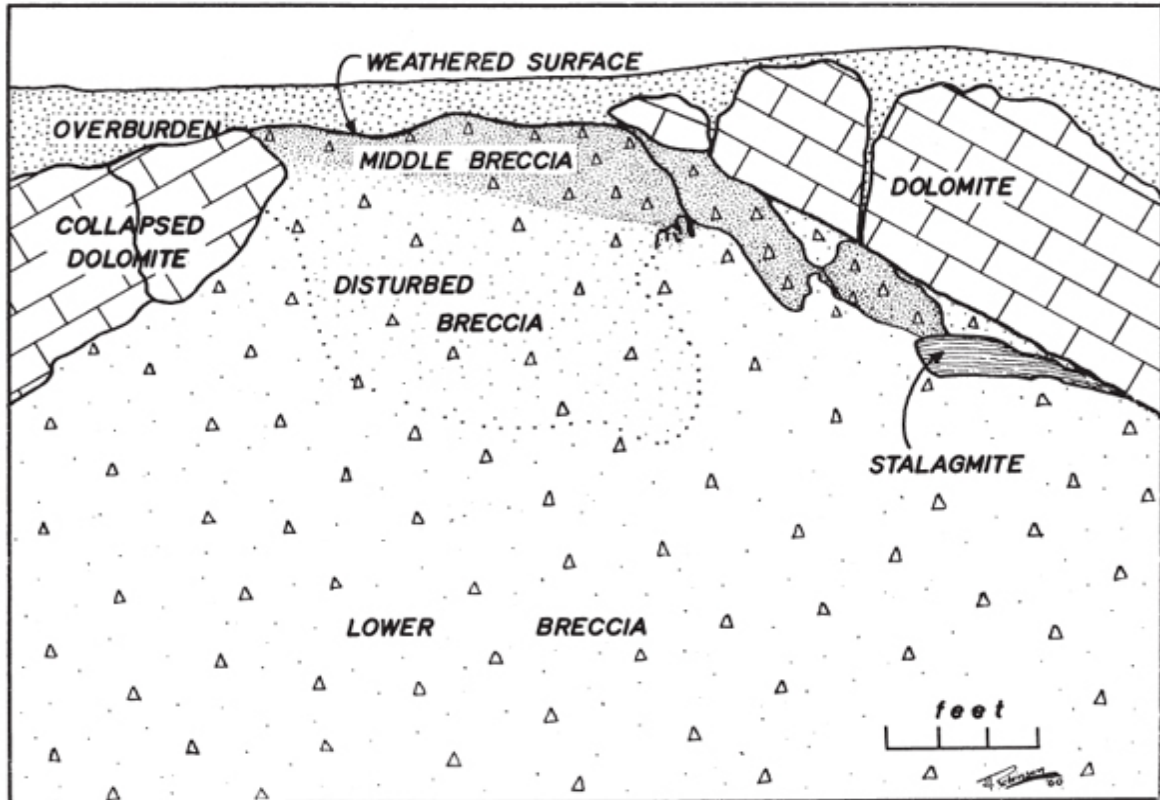

Figure 2.2. Robinson's 1962 Sterkfontein stratigraphy (from Robinson 1962).

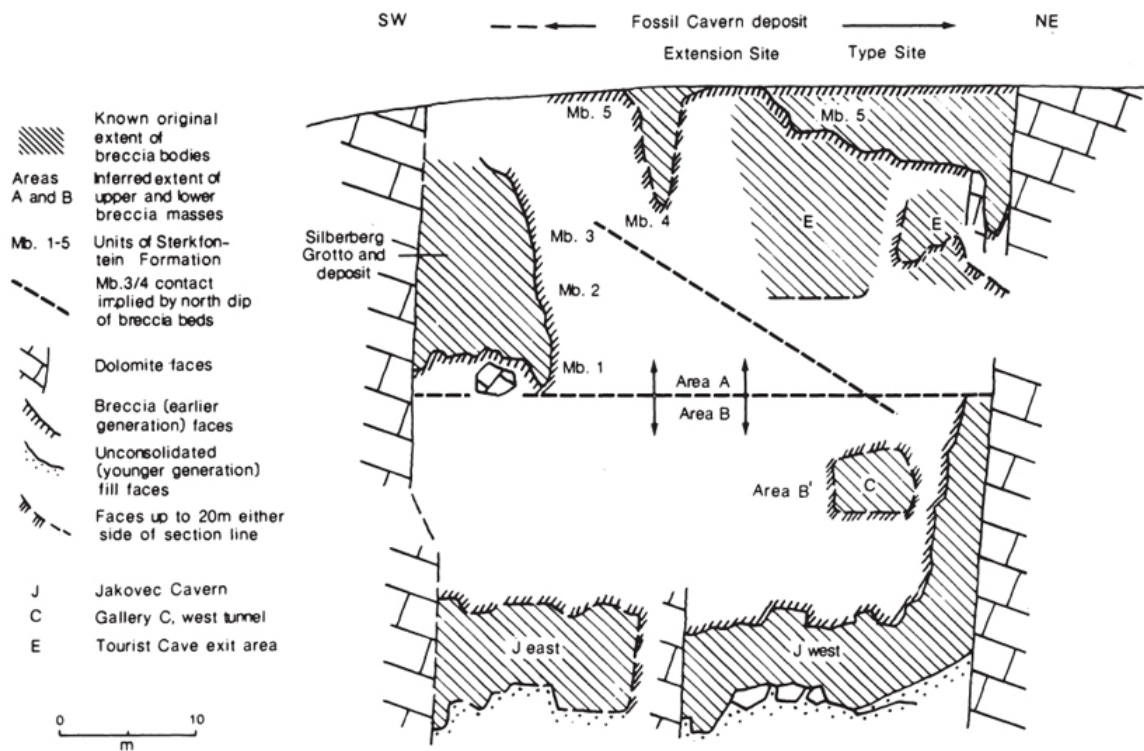

Figure 2.3. Wilkinson's 1983 Sterkfontein stratigraphy (from Wilkinson 1983).

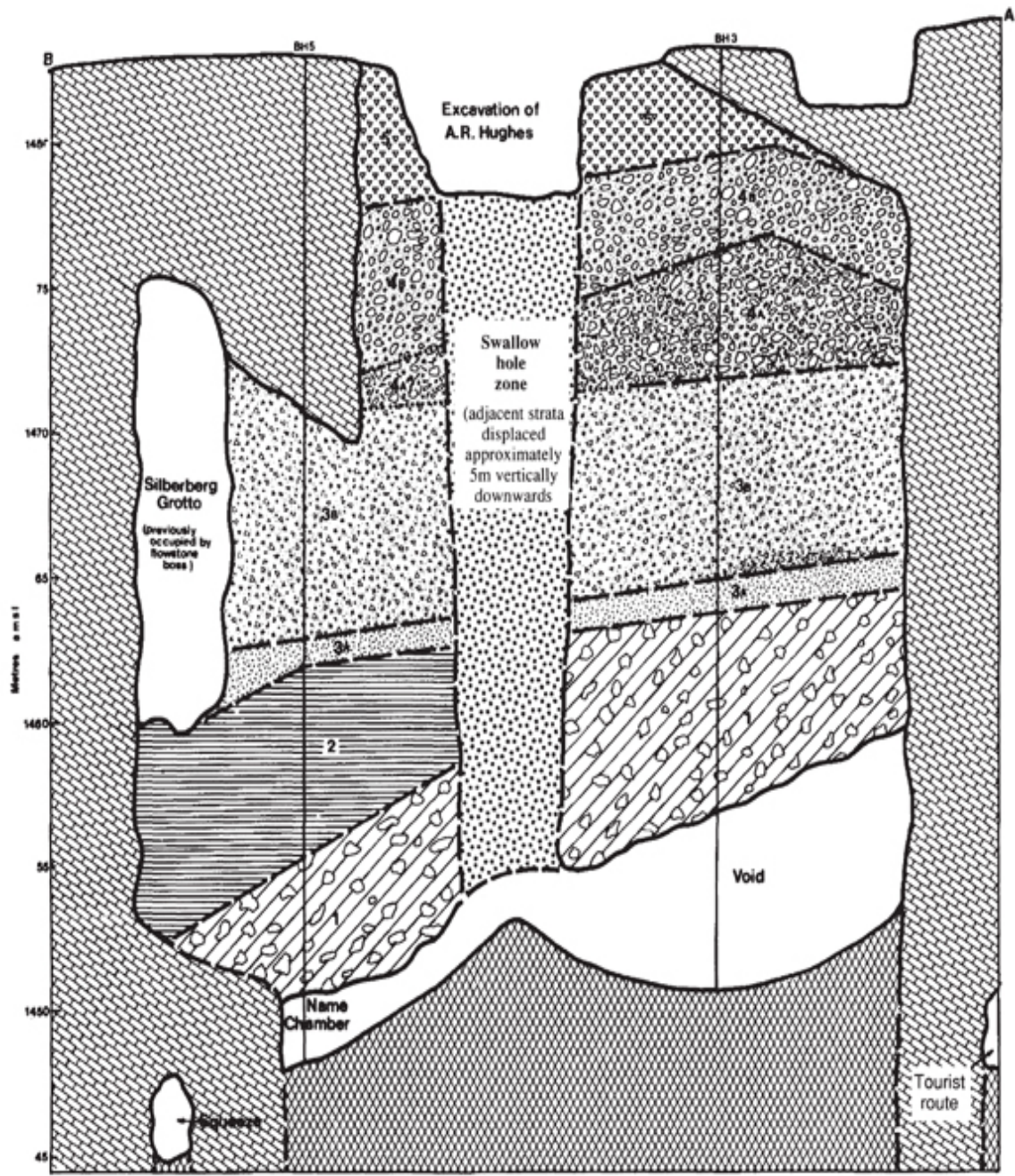

Figure 2.4. Partridge and Watt's 1991 Sterkfontein stratigraphy (from Partridge and Watt 1991).

2.2.2. Current Theory

Figure 2.5 shows Clarke's latest stratigraphic representation of the Sterkfontein members. This representation is an adaptation of Partridge and Watt's 1991 representation which is shown in Figure 2.4. Currently there are six members of breccia identified; these represent six different infilling events and subsequent calcification of sediment in the cave system. The comparison between faunal samples contained within these breccias and the East African, positively dated, samples have led to a greater understanding of the time periods represented by the breccias. The analysis of associated faunal remains has also led to a better understanding of how the deposits formed (Pickering 1999) and the environmental conditions at the time the deposit was being formed. Below is a brief account of each member, its age estimate and its formation process. This account is drawn from Clarke's 2006 paper on the Sterkfontein stratigraphy.

Member 1. Member 1 was formed before an opening to the surface was present so contains only collapsed dolomitic limestone roof blocks and chert. There are no faunal remains and so dating has not yet been possible. The collapse of the roof that formed the talus and the associated flowstone formations possibly took place 4 million years ago.

Member 2. This member was formed when a small opening in the Silberberg Grotto allowed the deposition of reddish sediment. Faunal remains were deposited when animals fell into the cavern through the small aven. Stalagmitic formations in the grotto indicate that the water table fluctuated and submerged part of or the entire cavern. Member 2 also includes a stony breccia containing the skeleton of a hominid, StW 573, along with large number of monkeys and carnivores that all fell to their deaths in the cave. Part of a thick flowstone sealed Member 2, which on the basis of cosmogenic and U-Pb analysis is judged to have formed between 4.17 to 3.3 million years ago (Partridge 2005). This date has been contested on the basis of potential faunal mixing and differently interpreted palaeomagnetic dating sequences yielding a date of no earlier than 3 million years old for the Member 2 deposit (Berger et al. 2002). Differently interpreted U-Pb dating methods have led to claims of between 2.24 and 2.17 million years old for the StW 573 hominid (Walker et al. 2006).

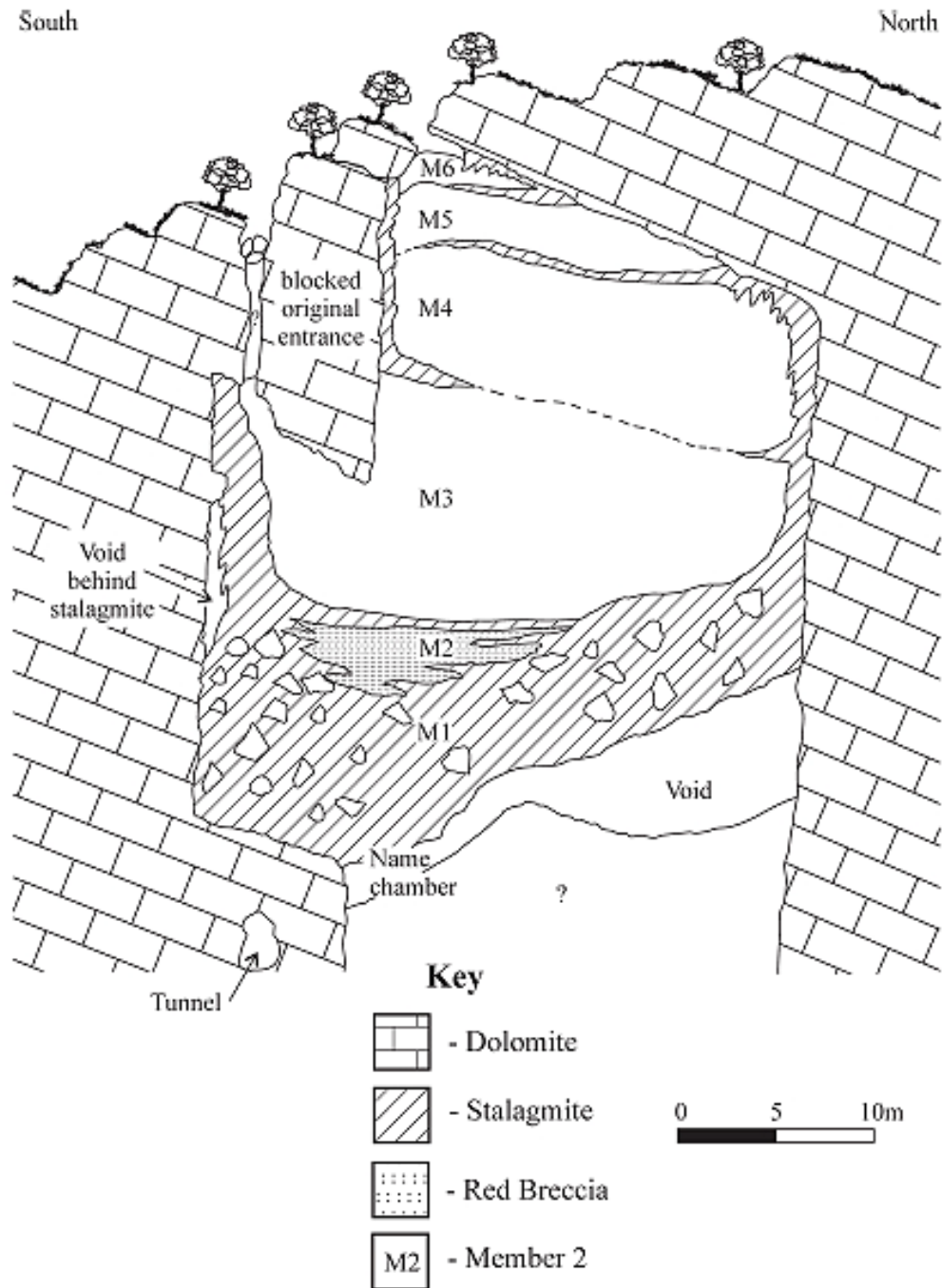

Figure 2.5. Clarke’s 2006 Sterkfontein stratigraphy. Schematic north-south section of Sterkfontein to show general relationship of breccias with suggested original openings and possible surface topography. (From Clarke 2006.)

Member 3. Member 3 is yet to be sampled but represents a huge deposit that rests on top of the Member 2 infill. The Member 3 deposit does contain bones that are yet to be excavated.

Member 4. This deposit represents the continued filling of the cave system by rock, sediment and bone in three beds (Partridge 1978), with the uppermost bed dated by palaeomagnetism to 2.14 Ma (Partridge 2003). The Member 4 sediments fill the cave to its roof and is currently the lowest level of the excavation from the surface. The original opening that fed the Member 4 talus deposit is thought to have been situated to the south southeast of the deposit (Robinson 1962; Partridge 1978). This member contains many fossil *Australopithecus* specimens as well as a greater variety of species and a high percentage of bovids (Kibii 2004). From these faunal remains and comparisons to East African faunal assemblages it has been determined that the Member 4 deposit formed at about 2.5 million years ago (Clarke 2006). Cosmogenic and U-Pb dating have given a possible date for the upper levels of Member 4 of 2.14 Ma (Partridge 2005). Berger et al. (2002) have argued for an age of 1.5 -2.5Ma for Member 4.

StW 53 Infill. Originally considered to be part of Member 5 due to its proximity to the artefact-bearing breccias and westerly position (Partridge and Watt 1991), this infill yielded the StW 53 cranium that Hughes and Tobias (1977) classified as *Homo habilis*. However, Kuman and Clarke (2000) have argued for a classification of *Australopithecus* for StW 53. Clarke recognised a division between the Member 5 breccia and the StW 53 breccia and following further excavations revealed that although the breccia has a close proximity to the Member 5 artefact-bearing deposit, there are no artefacts *in situ* within the hard StW 53 breccia (Clarke 1994). Clarke (1994) suggests that these two breccias represent two separate deposits. Previously no stratigraphic indications could be seen to separate the Member 5 and StW 53 breccias. As the excavations have deepened, a clearer stratigraphic distinction between these two breccias has become visible (Kuman and Clarke 2000). Pickering (1999) suggests that the cut marks visible on the zygomatic process on the maxilla of the StW 53 cranium are consistent with the disarticulation of the mandible through the slicing of the masseter muscles by a sharp stone tool. The absence of artefacts from the StW 53 breccia does not suggest that no tools were being used in the area around the 2 - 2.6 Ma. The absence of artefacts merely indicates that the tools were

not deposited into the cave system and that different depositional factors to the Member 5 infill may have been in effect during this time (Kuman and Clarke 2000). The StW 53 breccia is now considered to be a remnant of the Member 4 breccia (Clarke Personal communication) estimated to be over 2 Ma in age.

Member 5. Member 5 represents a change in climate and subsequently a change in the species of fauna deposited in to the cave (Pickering 1999). This change in climate has also been addressed by isotopic analysis of teeth from the deposits. Research by Luyt (2001) and Luyt and Lee-Thorp (2003) found the teeth of 40% of the faunal species sampled from the Member 5 Oldowan deposit were eating vegetation rich in C₄ carbon, indicating that 40% of the faunal species sampled were living in more open grassland environments and that these areas were close enough to contribute significantly to the cave deposit. This is close to their results of the Member 4 carbon isotopes in fossilised teeth, which came to 37% (Luyt 2001; Luyt and Lee-Thorp 2003). The Member 5 deposit contains the three main faunal indicators of a more open savannah landscape; *Equus*, *Pedetes* and *Struthio* (Kuman and Clarke 2000). Substantial proportions of clay in the Member 5 Oldowan sediment also indicate a more stable environment with less surface erosion (Partridge, quoted in Tobias, Clarke and White 1993). The Member 5 deposit formed in a talus slope formation unconformably against the Member 4 talus. Importantly Member 5 contains the first stone artefacts of the Sterkfontein system. Oldowan artefacts originally estimated at about 1.7 to 2.0 Ma by Kuman and Clarke (2000) have now been dated by the Cosmogenic Nuclide burial method to over 2 Ma (Gibbon, R. personal communication). Early Acheulean tools have also been recovered and are estimated to 1.4 – 1.7 Ma (Kuman and Clarke 2000). The Early Acheulean tools are found in association with fragmentary fossils of *Homo ergaster*, while the Oldowan Infill has several fossils of *Paranthropus robustus* (*ibid.*).

Member 6. Member 6 is the smallest of the Sterkfontein deposits. This deposit formed on top of the flowstone that capped Member 5 West and filled the remainder of the cavern to the roof only at the western end of the site. The Member 6 deposit contains bone, the only ‘foreign stone’ found in the deposit was stolen before it could be extracted (Robinson 1962). Water erosion later eroded much of this breccia, along with the central area of the Member 5 Acheulean breccias. A younger infill with some Middle Stone Age

material later filled the gap, creating the Post-Member 6 Infill (Kuman and Clarke 2000), which appears to be continuous with the adjacent Lincoln Cave infills (Reynolds et al. 2007).

2.2.3. Previous Name Chamber stratigraphy and formation

In 1962 Robinson proposed the first hypothesis regarding the formation of the Name Chamber talus cone. Robinson climbed to the top of the talus where he removed three core artefacts from ‘disturbed middle breccia at the top of the slope,’ ‘high in the roof of the underground system’ (Robinson 1962). Robinson judged from the sound of his workers’ hammering above that he was ‘directly beneath the western extremity of the Extension Site.’ (Robinson 1962). This equates with the grid line 65 in the current excavation. Robinson suggested that the Name Chamber deposit, at least in part, contained breccia deriving from the above ‘Extension Site’ deposit (Robinson 1962). Robinson also suggested that the cavern was first filled after a collapse of the lower breccia (now known as Member 4). This collapse can be seen in the lower reaches of the deposit in the Name Chamber. The cavern then filled to its roof with what Robinson referred to as ‘middle breccia’, this was cemented. Further ‘minor collapses and readjustments in the collapsed and re-cemented material in the lower system once more opened up a space under the roof’, the sediment that filled this space was the upper breccia (Robinson 1962).

In the early 1990’s, Clarke was able to clarify the connection between the Name Chamber talus and the Member 5 deposits. While excavating the Oldowan deposit, Clarke (1994) uncovered two cavities leading downwards. Clarke inserted a hosepipe into the holes, the end of which emerged in the Name Chamber from the roof of the western side of the talus cone, clarifying the connection between the two deposits first suggested by Robinson (Figure 2.6). Further excavations in 1994 enlarged this cavity in the base of the Oldowan Member 5 deposit. With the help of Jacques Martini, Harvey Moen and André Keyser, a wire ladder was lowered down the large cavity into the Name Chamber. The two speleologists Moen and Keyser made the descent and passed through the 12.5 meter shaft into the Name Chamber below. Moen and Keyser passed through decalcified breccia in the upper part of the descent and large interlocking blocks of dolomite in the lower part of the descent. Clarke suggested the following hypothetical sequence for the formation of the Name Chamber deposit, as illustrated in Figs. 2.6-2.8.

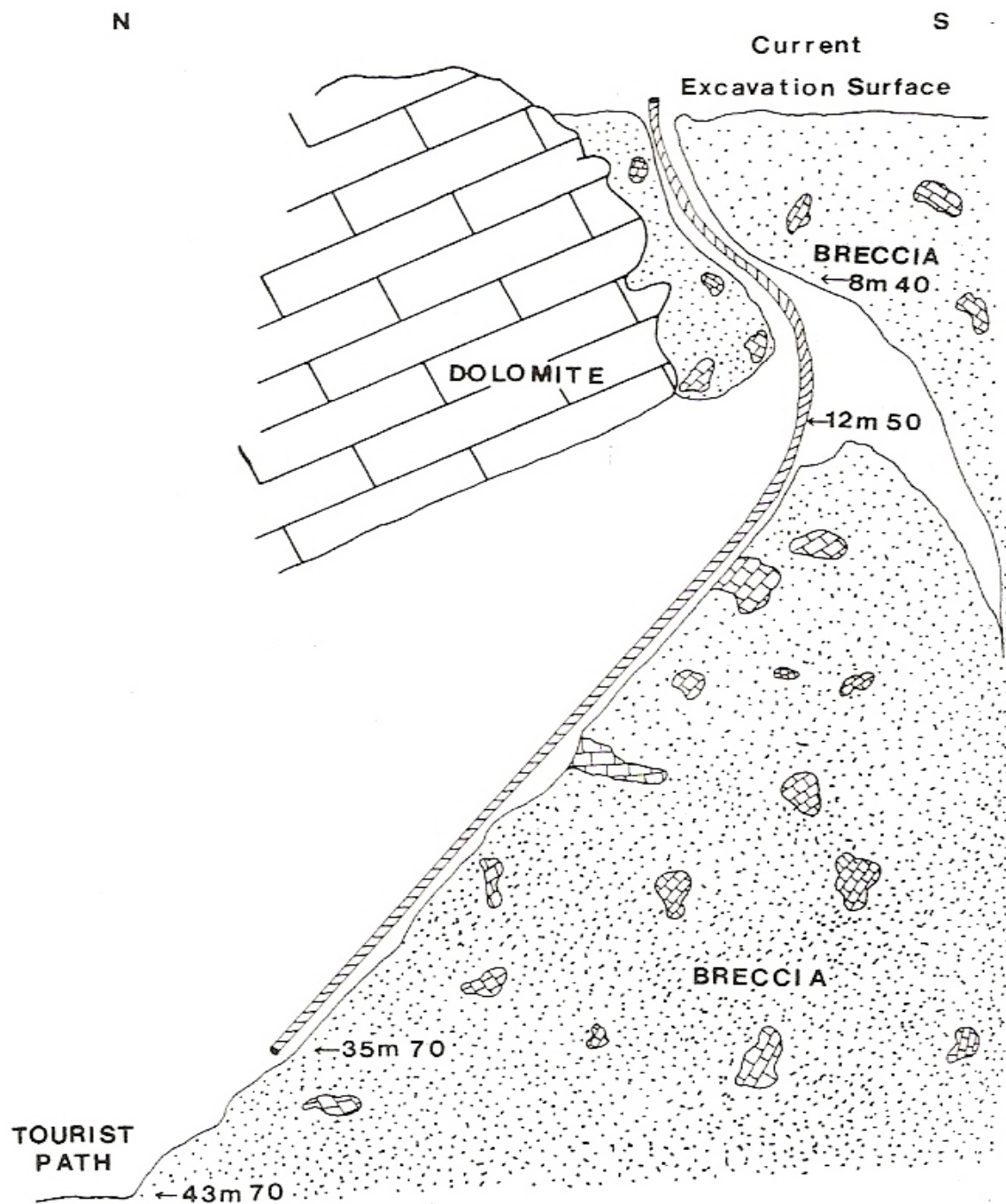

Figure 2.6. Schematic north-south section through talus cone on the Name Chamber, showing connection with Oldowan area above. Measurements are given along the length of the hosepipe from the current excavation surface (From Clarke 1994).

1. At first...“stony breccia entered the chamber through a shaft to the south and partially filled the cavern (Figure 2.7). The *Homo habilis* cranium StW53 was excavated from this breccia at the surface.
2. The roof at A collapsed onto the lightly calcified breccia at B.
3. The roof of the lower cavern at C collapsed, together with the breccia above it.
4. Later a new opening at A allowed ingress of the Oldowan deposit, D, containing stone tools washed in from outside the cavern where hominids were probably using the trees as shelter (Figure 2.8).
5. The consolidated stony breccia beneath the roof to the south continued to crack and slump towards the opening into the lower cave. Cavities and cracks formed through such slumping were filled with orange sandy breccia, E, containing Early Acheulean artefacts and were then consolidated by calcium rich water dripping from the roof. Further settling caused cracks which were then filled with travertine. Chunks of the stony breccia were incorporated within the sandy orange breccia as Robinson (1962) observed. These two visually distinct sediments are sedimentologically indistinguishable according to Partridge.
6. With further roof collapse and ingress of water during rainy seasons, the breccia in the de-roofed area remained loosely calcified and percolating water was later to form the huge solution cavity in the Oldowan deposit through which the hosepipe and the speleologists passed to the Name Chamber beneath” (Clarke 1994: 214).

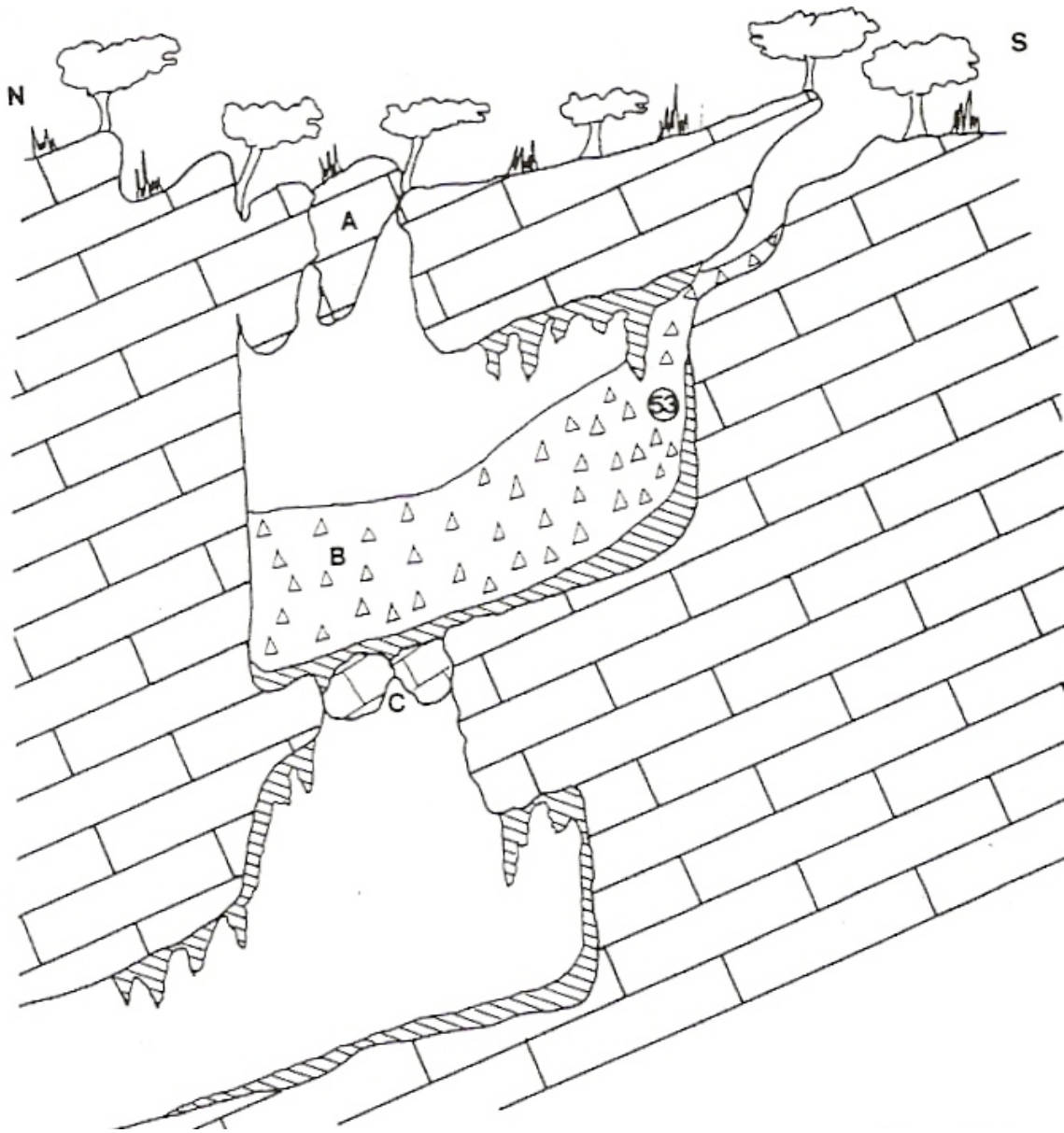

Figure 2.7. Hypothetical reconstruction of the Extension Site cavern to show ingress of stony breccia with loosely calcified area at B, and dolomitic limestone labelled as A (from Clarke 1994).

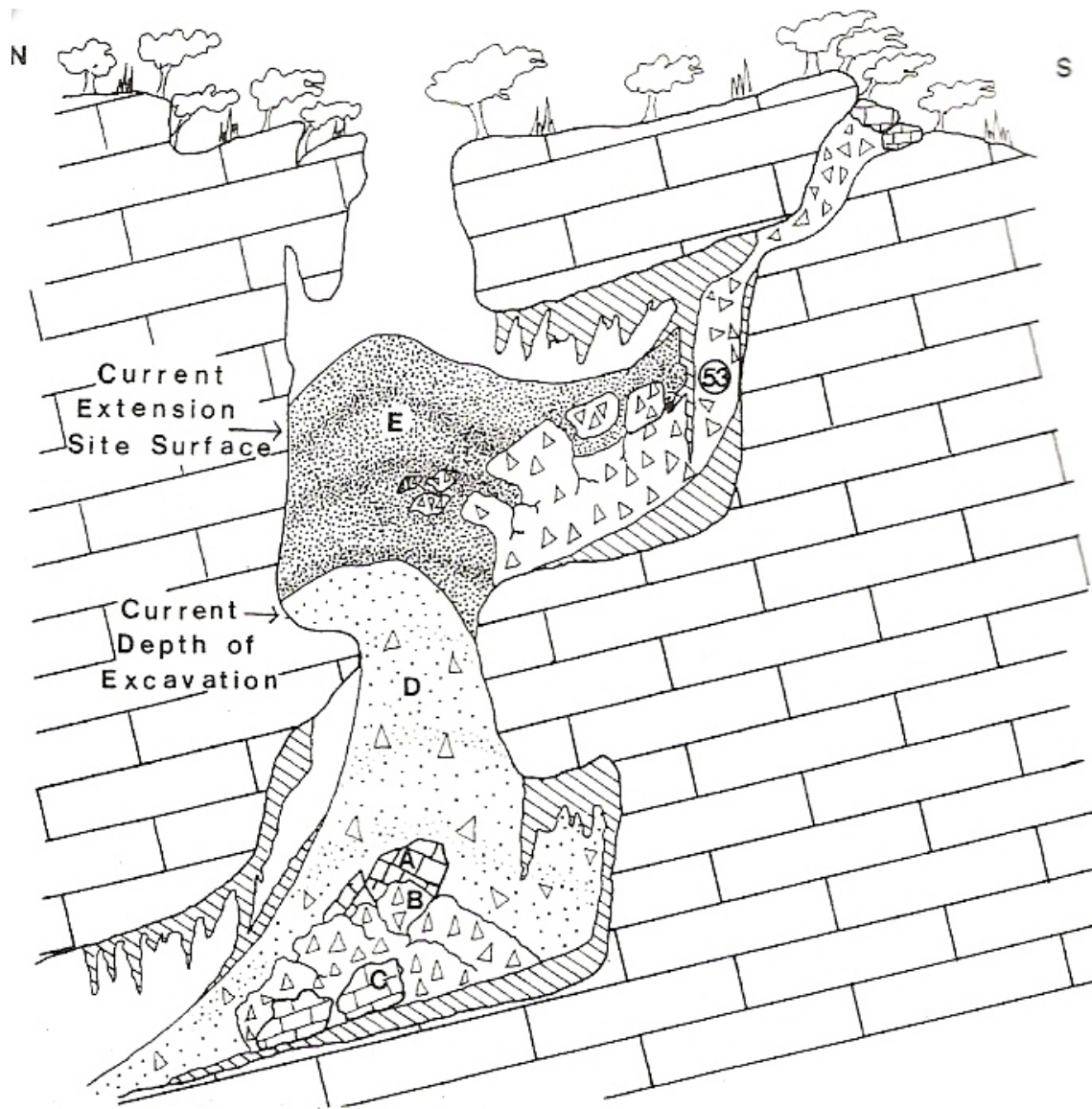

Figure 2.8. Later Hypothetical stage to show collapse and infilling of the Extension Site cavern and Name Chamber beneath (From Clarke 1994).

During Partridge's core drilling programme in 1989, one of the bore holes (BH5) was situated 25 meters south-east of where the current hole to the Name Chamber was uncovered. The drill also broke through the roof of the Name Chamber and when the sediments were recovered from the core, several members were identified (Partridge and Watt 1991). The core first passed through the dolomite roof and then through a thin section of Member 5 before passing through members 4, 3 and 1 and then breaking through into the Name Chamber above the base of the talus slope. This demonstrates a continuum of deposits from the surface excavations to the tourist path at the base of the Name Chamber (Clarke 1994). What is not clear is what is contained in the Name Chamber deposit. Clarke has postulated that the remnants of the collapsed dolomite roof blocks and perhaps earlier breccia lies at the centre (Clarke 1994). Unfortunately the size and steepness of the Name Chamber talus make it difficult to excavate intrusively into the deposit. The current excavations have only sampled the outer poorly calcified outer layers of the deposit. Therefore, even after excavations into the talus, the contents of the centre and the evidence of the exact sequence of formation are still unknown. The only realistic way of sampling the centre of the cone without destabilising the deposit and possibly causing collapse is core drilling (Kuman personal communication.).

As this thesis is interested in the tool-bearing breccia and sediments of Member 5 it is important to give a detailed description of these breccias (Figure 2.9). Originally the stratigraphy of Member 5 was thought to be relatively simple; the formation of a large talus deposit similar to that of Member 4 was said to receive debris and fauna from an opening to the south southeast similar to Member 4 (Robinson 1962; Partridge 1978). Recent excavations have revealed a more complicated scenario. Both Clarke and Brain attest to the difficulties in the analysis of cave deposit stratigraphy as many factors influence the deposition of sediments that can, to the naked eye, look identical and may only be identified as separate depositional sequences by fauna and archaeology (Brain 1993; Clarke 1985).

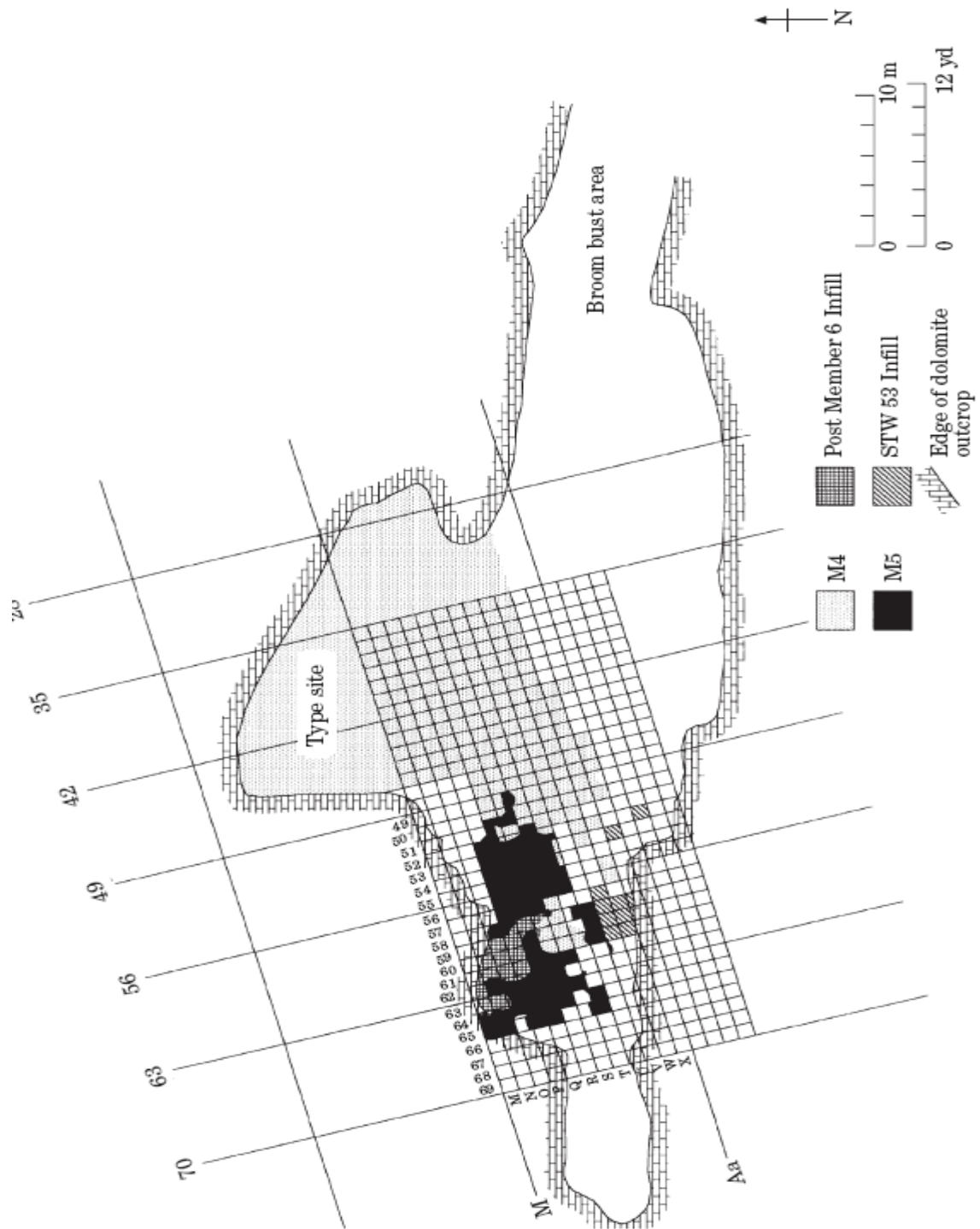

Figure 2.9. Sterkfontein main excavation, with the positions of Members 4, 5 and the StW 53 deposit (from Kuman and Clarke 2000).

Member 5 East

The Member 5 East deposit currently yields the largest of the stone tool assemblages in the Sterkfontein site. The Oldowan collection is represented by 3513 artefacts (the details of which are summarized in Chapter 3). The Oldowan assemblage was excavated at a depth of 22'00" to 36'10" (below datum) and through the grid lines 49 to 58. The area above this (at the 20' level and higher), yielded a small number of diagnostic Early Acheulean artefacts and a large number of artefacts which may possibly be a mix of Acheulean and younger material, due to the intrusion of solution pockets (Kuman 1994a). There also seems to be a sedimentological difference between the lower Oldowan bearing breccia and the upper Acheulean bearing breccia (Kuman 1994a; Kuman and Clarke 2000). Collapsed roof blocks in the Member 5 East Acheulean breccia are orientated on a tilt consistent with a talus slope (Kuman and Clarke 2000). Figure 2.10 represents an east-west profile of the northern wall of the Member 5 East breccia. The resultant mixing of Oldowan, Acheulean and MSA material caused by the solution pockets makes this upper area less profitable in terms of yielding positive technological conclusions (Kuman 1994b).

Member 5 West

The Member 5 West breccia extends into the Extension Site originally excavated by Robinson (1962). This deposit contains the best preserved Acheulean assemblages from the Sterkfontein breccias. In the stratigraphic diagram below (Figure 2.10) one can see a portion of Member 5 West on the northern wall. This breccia is heavily calcified and remains very hard, unlike Member 5 East where solution pockets intrude into the top 20' of the deposit (Kuman and Clarke 2000).

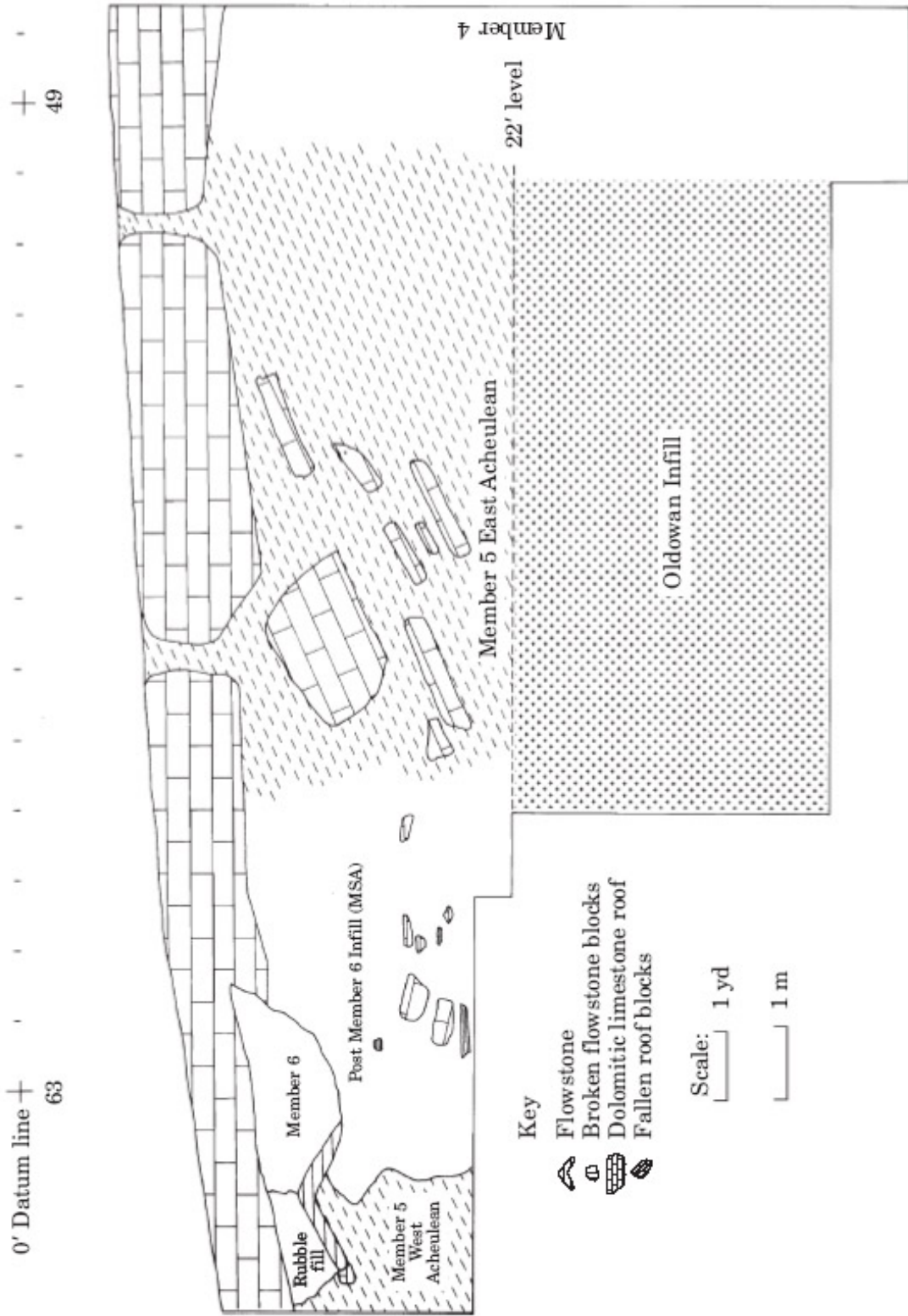

Figure 2.10. East-west profile of the northern wall of the Member 5 breccia (from Kuman and Clarke 2000).

Member 5 taphonomic research

Pickering's doctoral thesis paid particular attention to the faunal accumulation of the Member 5 deposits. For the StW 53 deposit he concluded that the low percentage representation of mammalian modified bone, 4.32%, suggests that the StW 53 deposit is not the result of carnivore accumulation processes (Pickering 1999). The lack of juvenile carnivore remains, coprolites, and digested bones suggests that the cave entrance was also not used as a den site. The StW 53 breccia faunal remains suggest that the majority of bone modification occurred through natural weathering conditions associated with cave deposits, and this evidence led Pickering to conclude that the Member 5 South deposit (StW 53 deposit) was naturally accumulated through slope wash and environmental agents.

For the Member 5 Oldowan which is in Member 5 East, Pickering concurred with Kuman and Clarke's proposal that the Member 5 Oldowan Infill accumulated through an aven high above the cave floor (Clarke 1994). The resulting talus contained faunal remains that supported a death trap accumulation scenario, namely: all major skeletal portions are represented in the deposit; modified bones represent very low proportions of the assemblage; roughly natural proportions of local taxa are present. Pickering postulated that a relatively high proportion of fully represented skeletal parts of non-human primates suggested that these species occupied the local vicinity (may have inhabited the tree systems above the cave opening and fallen in from the foliage above). Only a minor component of fauna in the Oldowan Infill was said to derive from slope wash (Pickering 1999).

The faunal remains of Member 5 West suggest that the primary bone accumulation agent was the brown hyaena (*Parahyaena brunnea*). The large proportion of carnivore bones, 30.6%, plus the diversity of the taxa combined with the nature of the non-carnivore remains, allowed Pickering to suggest that the Member 5 West cave opening was used for a den site for multiple generations of brown hyaena, leading to the accumulation of the faunal remains (Pickering 1999).

2.3. Previous and Current Theory of Lithic Analysis

Leakey's theories regarding the Oldowan industry revolved around the concept that Oldowan core tools were deliberately designed for use (Leakey 1971). Although Leakey conceded that some 'flake debris' may provide sharp edges that can be used for cutting, the principle tools of the Oldowan hominid were, in her scheme, the more heavy duty core tools. Research in the 1980's called for the re-interpretation of Plio-Pleistocene tool use and manufacture. Instigated by Toth's reassessment of the Oldowan, modern researchers now consider the Oldowan technology to represent a 'least effort' approach to the production of flakes, which are considered to be the primary objective of the Oldowan knapper (Toth 1985). This theory has had considerable impact on the excavation and collection practices of ESA lithic evidence (Semaw 2000; Schick 1987a, b). Increased attention paid to all elements of the assemblage has led researchers to a much greater understanding of the advanced capabilities and practices of the Oldowan knapper (Delagnes and Roche 2005; Semaw 2000, 2007; de la Torre 2004; de la Torre et al. 2003), the spatial distribution of the knapping practice (Newcomer and de G. Sieveking 1980; Toth and Schick 1986), the raw material procurement practices (Toth 1982; Stout et al. 2005), and to the processes affecting site formation in terms of technological evidence (Kroll 1994; Petraglia and Potts 1994; Plummer 2005; Schick 1997). Of key importance to this study is the analysis of flaking debris. Great advances have been made in the analysis and understanding of the by-products of knapping.

All of the above specialist disciplines in lithic interpretation stem from the concept of 'chaîne opératoire'. First used by A. Leroi-Gourhan in 1943 in his groundbreaking work *L'homme et la Matière*, the concept of 'chaîne opératoire' has become fundamental in all assemblage analysis. It has been defined as follows:

"Chaîne opératoire encompasses all the successive processes from the procurement of raw material until it is discarded, passing through all the stages of manufacture and use of the different components. The concept of chaîne opératoire makes it possible to structure man's use of raw materials by placing each artefact in a technical context and offers a methodological framework for each level of interpretation" (Inizan et al. 1999: 14).

The drive towards a more encompassing understanding of the use of stone in all contexts, from procurement to discard, has led to a more technological approach to all fields of lithic analysis and away from the more rigid typological systems employed by

Leakey. However, the typological sequence of formal, diagnostic tool types remains an important base for comparison of any ESA assemblage.

As part of this research is specifically concerned with the deposition of flaking debris, it is necessary to give a review of the approaches to debris analysis that have been developed, adapted and used to good effect. Donald Crabtree described debitage as the 'finger prints' of stone tool production (Crabtree 1972). He recognised that the analysis of flaking debitage¹ could reveal many aspects of stone tool production without the tools being present. Debitage analysis has been defined as "the systematic study of chipped stone artefacts that are not cores or tools" (Sullivan and Rozen 1985: 755). Debitage and debris analysis has been successfully used to determine the types of artefacts used (Austin 1999; Patterson 1990), the method of tool production (Dibble 1995; Kuijt et al. 1995), and the type and stage of core reduction (Carr and Bradbury 2001). Increased understanding of debitage and debris production processes and subsequent analysis has led to more accurate inferences concerning site formation processes (Fladmark 1982; Hull 1987; Nadel 1999) and palaeolithic land use theories (Andrefsky 2001; Bamforth 1991; Stahle and Dunn 1982). Through the diligent excavation of sites, debitage analysis has become instrumental in the development of theories concerning all steps of tool use, from raw material procurement and initial shaping, through tool maintenance and core reduction to discard. These theories, in turn, have yielded more accurate analysis of foraging and mobility strategies - for an example see Brooke (2003). All stages of stone tool development create debitage and debris.

Through experimental knapping, tool debitage and debris signatures have been created and the material used as reference collections for excavated assemblages (Andrefsky 1986; Cotterell and Kamminga 1979, 1987, 1990; Speth 1972, 1974, 1975, 1981). These signatures have been used to assess the completeness of the assemblage and, when the tool is not present within the collection, make inferences regarding type of tool produced, stage of core reduction and method of reduction.

¹ In this thesis 'debitage' refers to debitage in the conventional sense, debris representing a by-product part of the stone assemblage not to be utilised. Conventionally the term debitage is defined as the "intentional knapping of blocks of raw material, in order to obtain products that will either be subsequently shaped or retouched, or directly used without further modification" (Inizan 1999 et al. : 138). Debris, however, is defined as "shapeless fragments whose mode of fracture cannot be identified and cannot be assigned to any category of object" (Inizan et al. 1999: 138). Many lithic studies refer to debris as being debitage, and to debitage studies as mainly the study of debris. This research uses the definitions set out above, debris and debitage representing different parts of an assemblage.

However, Ahler, and more recently Andrefsky, have investigated the efficacy of these signatures and found them to be unreliable bench marks for assemblage comparison. They demonstrate that comparisons between experimental assemblages and archaeological assemblages can be useful in that experiments produce similar debitage and debris typologies, but the proportions of these artefacts within assemblages are highly variable due to raw material size and type, knapping technique used, intention of knapper and the skill of individual knappers (Ahler 1989; Andrefsky 2006). Other researchers have also demonstrated similar variability within experiments (Olausson 1997; Shelley 1990). This variability has led to drawbacks in certain methods of debitage and debris analysis. Because of the high level of assumption within direct comparisons between archaeological and experimental assemblages (e.g., assumptions like raw material size comparability, shape, knapper intention and skill) certain types of debitage and debris analysis, such as mass analysis, are likely to be less accurate than previously thought (Sullivan and Rozen 1985; Andrefsky 2006).

Andrefsky cites Sullivan and Rozen's 1985 paper "Debitage analysis and archaeological interpretation" as one of the most influential articles on debitage analysis in the past 15 years (Andrefsky 2001). Although many problems with their flake typologies have been pointed out (Johnson 2001), the work "can incite great passion among debitage analysts" (Whittaker and Kaldahl 2001). The key to Sullivan and Rozen's work is the recognition of the drawbacks associated with current debitage analysis. Current debitage classification and interpretation is based upon tenuous flake typologies, based in turn upon presumed technological origins. They suggest the use of "interpretation-free and mutually exclusive debitage categories" (Sullivan and Rozen 1985). Essentially Sullivan and Rozen restrict the number of technological inferences at the artefact level. By standardising the classification of debitage flakes, Sullivan and Rozen hope to promote inter-assemblage comparisons. They divide debitage flakes into 4 types; Complete flakes; Broken flakes; Flake fragments; Debris. No flake size constraints are given by Sullivan and Rozen, suggesting that all flakes with discernable features are classified. Within these four categories are three dimensions of variability. The first is the Single Interior Surface identified by features such as ripple marks, force lines and bulbs of percussion. The second dimension of variability is the Point of Applied Force, found at the intersection of the bulb of percussion and the striking platform. On artefacts with only a partial remaining striking platform, force lines can indicate the general location of the Point of Applied

Force. Obviously flakes with no Single Interior Surface also have no Point of Applied Force. The third dimension of variability is Margins; the presence of the distal termination type (feather, hinge or step) and lateral portions of the flake allow maximum width measurements to be taken and provide the information for the debitage margins to be complete and present. Table 2.1 shows the technological attribute key to define the four debitage types.

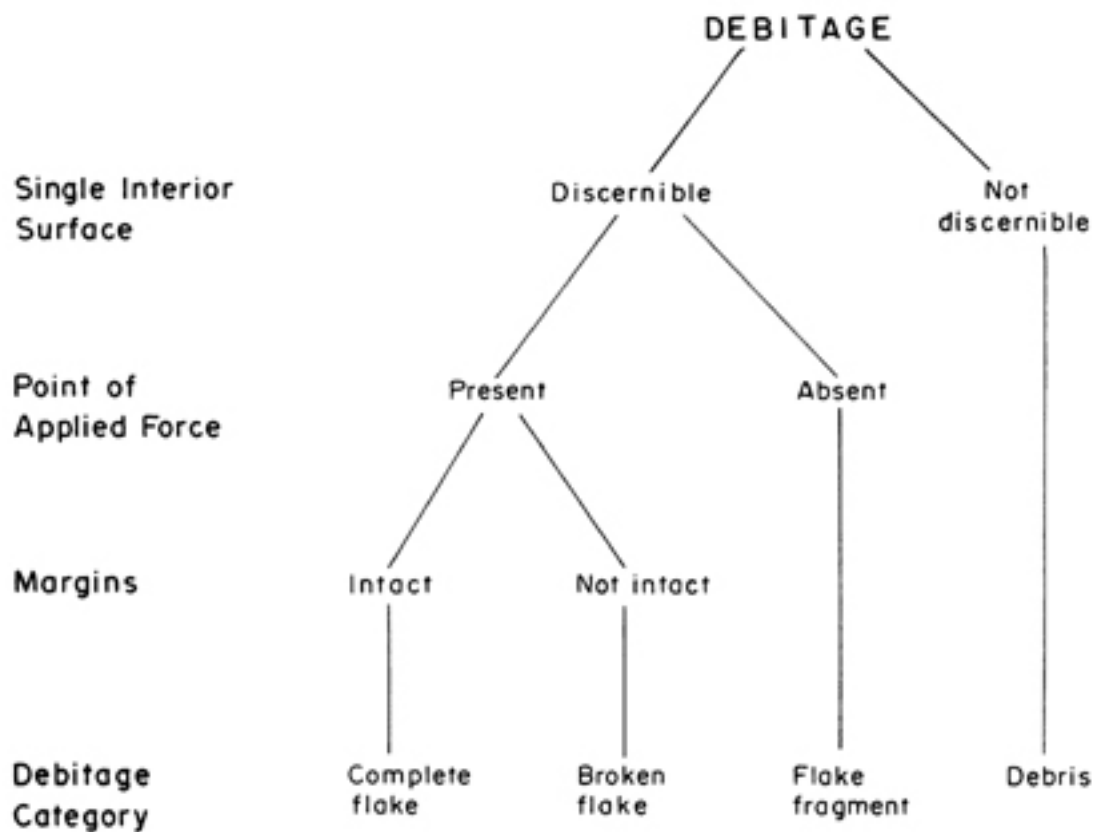

Table 2.1. Sullivan and Rozen’s (1985) flake technological attribute key.

Sullivan and Rozen argue that using this interpretation-free method of debitage classification “allows the effects of cortical variation, raw material source characteristics, regional reduction strategies and other factors to be controlled and evaluated when investigating the processes that contribute to variability in prehistoric chipped stone assemblages” (Sullivan and Rozen 1985: 759). The ability to classify and quantify debitage at artefact level prior to technological inference is important as it allows a greater understanding of context-unique assemblage characteristics without using potentially

loaded technological terms to classify the debitage. The different proportions of these flake types may relate to different reduction techniques or raw material properties and thus assist with technological interpretation. However, Johnson points out the drawbacks of such an approach. “The more fundamental problem with the Sullivan-Rozen technique (SRT) is that we want our typologies to do more than predict, we want them to explain” (Johnson 2001). It is difficult to approach an analysis with a multivariate method using interpretation-free classifications. In the same paper Johnson goes on to say “...many if not most of our (debitage analyst’s) flake typologies were based on assumptions about the relationship between behaviour and by-product”.

Prentiss creates an experimental assemblage in order to test the success of the SRT. Prentiss concludes that although the SRT provides reliable results and is relatively free of random error (provided operator error is minimised) it is evident that this technique is not accurate when measuring vitreous or very brittle raw materials, where large numbers of distal and medial fragments are produced. The fundamental problem Prentiss’ paper identifies is the need to recognise flake size profiles as an assemblage variable. With this shortfall the variability between core reduction profiles and tool reduction profiles is narrowed and homogenised. Prentiss suggests that size of flake should be added to the SRT variables, therefore allowing flake breakage patterns to be established (Prentiss 1998). It is recognised by researchers that flake breakage patterns correlate with reduction strategies (Stahl and Dunn 1982; Ahler 1989; Schott 1994), but the actual breakage patterns are not characterised well by the SRT variables. By adding a flake size profile to the SRT and being able to analyse the breakage patterns per size category, one can obtain a much higher degree of success and accuracy in evaluating the reduction technique. Named the Modified Sullivan and Rozen Technique (MSRT), Prentiss’ method also allows the recognition of percussor type, through replication comparisons, which was previously un-explored by the original SRT.

The Mass Analysis (MA) technique has become increasingly popular and is preferred by many researchers over individual analysis techniques, due to its relative speed and simplicity. Ahler demonstrates that Mass Analysis:

- (1) can be applied to the full range of debitage without regarding fracture or completeness, thereby eliminating potential bias resulting from exclusion of some debitage forms, such as broken or shattered pieces;

- (2) can be rapid and efficient, even for extremely large debitage samples, because it does not require handling and measuring of individual specimens;
- (3) can reduce technological bias based upon debitage size because different mesh sizes capture a range of different specimen sizes;
- (4) can be a highly objective technique since the analysis involves size grading, counting, and weighing, and can be conducted by virtually anyone trained in elementary lab procedures (Ahler 1989)

It is easy to see why researchers prefer the use of Mass Analysis, but as highlighted the technique has many theoretical draw backs that need to be taken into account if accurate interpretations regarding the debitage or debris assemblage are to be made (Shott 1994; Andrefsky 2006). General relationships between platform facets and core reduction (e.g. Bradbury and Carr 1995; Magne 1985) and mass and reduction (Ahler 1989; Shott 1994) have been established by several researchers.

In Bradbury and Carr's paper an attempt is made to create a "standardised measure of reduction to refer to the difference in the weight of the starting and the ending point of core reduction (i.e. raw nodule weight minus the final core weight). If a relationship between the difference in weight and other flake attributes can be determined, then a standardised measure of reduction, or analytical core unit (ACU) can be formulated" (Bradbury and Carr 2001). The ACU is a theoretical core model that is produced by back-tracking the flaking debris versus the core weight to come up with an original core model, thereby allowing inferences to be made regarding the intensity of reduction, a question that is of key importance to all archaeologists dealing with stone assemblages. Using common flake analytical units, such as flake count (in different size categories), number of flakes with remaining platforms, number of complete and incomplete flakes, number of flakes with dorsal cortex and number of dorsal flake scars, Carr and Bradbury created an experimental database of flake debris. They acknowledge that none of the above basic units of analysis "can reliably classify all the individual flakes in an assemblage to a reduction type" and a combination of several different units is needed to more accurately produce an ACU. In their experiments Carr and Bradbury use the complete and platform bearing flakes between the sizes of $\frac{1}{4}$ inch (6.5mm) and $\frac{3}{4}$ inch (19mm). By determining a relationship between core reduction weight difference and numbers of flakes with

platforms between the ¼ inch and ¾ inch, calculations can also be made to estimate the number of flakes produced in a reduction sequence.

Bradbury and Carr suggest that their model can be used to calculate the core reduction on a wide range of assemblages when the exhausted core is not recovered and only the flaking debris remains. They also suggest that this model is not raw material dependant (Bradbury and Carr 2001). One must bear in mind that these experiments were undertaken on American flint and profited from the good flake attribute retention that is common on good quality flints and cherts. Accurate results could be obtained from these equations on European assemblages which use similarly good quality raw materials. However, on African stone assemblages, especially Oldowan and Early Acheulean collections, the dominance of quartz and quartzite as a raw material means flake attribute retention is very poor. The high proportion of quartz in these assemblages poses major problems. Due to the flaking characteristic of quartz which produces high proportions of flakes with no platforms, incomplete flakes, flake fragments and small <¼inch (6.5mm) shatter, it would, unfortunately, be difficult to apply Bradbury and Carr's equations.

The approaches to debris analysis outlined above demonstrate the increased attention flaking debris is receiving in the quest to utilize all facets of an archaeological assemblage. Raw material fracture dynamics influence the number of methods applicable to individual assemblages.

“Due to the lack of control over fracturing and the high frequency of accidental breaks, quartz industries have been seen by analysts as second rate industries” (Mourre 1996: 205). Dedicated work on the flaking properties of quartz have been restricted to specialised flaking experiments concentrating on local quartz such as conducted by Kuman and McNabb (Kuman et al. 2005). The variability of quartz qualities can restrict general flaking properties and the meaningful definition of its weathering stages. Mourre's (1996) work makes an attempt to bring together the established knowledge regarding the flaking tendencies and general patterns endemic to quartz flaking events and assemblages, but it acknowledges the complications in the technological analysis of quartz based industries. Mourre continues to identify the features regularly present on flaked quartz and proposes a quartz specific methodology for analysis based on the work of Tavano (1972, 1976). Mourre stresses the problems involved in the comparison of non-quartz and quartz based industries due to the very different assemblage component composition.

Chapter 3. Materials and Methodology

3.1. Current Sterkfontein Assemblages.

Both the collections analysed in this research are compared to the Oldowan and Early Acheulean of Sterkfontein. The Oldowan and Early Acheulean represent the largest of the Sterkfontein stone tool assemblages and provide the greatest comparative sample.

Oldowan

Oldowan artefacts have only been recovered from Member 5 East breccia, which accumulated against the vast Member 4 breccia that has filled the eastern half of the site exposed in surface excavation. Detailed findings of the Oldowan assemblage are given in Kuman and Field (2008) and in the comparison with the Name Chamber assemblage presented in the Chapter 5 archaeological analysis. In this section an overview of the assemblage profiles, features and interpretations is presented.

The Oldowan assemblage was excavated by R.J. Clarke in the early 1990's from Member 5 East the western end of the surface excavation site (Clarke 1994; Kuman 1994a; Kuman and Clarke 2000). The assemblage consists of 3500 artefacts and 13 manuports, the composition of which is shown in Table 3.1.

	quartzite	chert	quartz	Total	%
Small flaking debris <20mm	9	204	2744	2957	84.17%
Complete flakes	20	7	57	84	2.39%
Incomplete flakes	38	22	231	291	8.28%
Chunks	11	0	120	131	3.73%
Retouched pieces	1	1	5	7	0.20%
Core tools	1	0	0	1	0.03%
Cores	7	0	17	24	0.68%
Core fragments	1	1	3	5	0.14%
Manuports	7	1	2	10	0.28%
Manuports?	2	0	1	3	0.09%
TOTAL	97	236	3180	3513	100.00%
%	2.76%	6.72%	90.52%	100.00%	

Table 3.1. Artefact types and raw materials for the Sterkfontein Oldowan assemblage. (from Kuman and Field 2008).

As one can see the majority of the assemblage is quartz flaking debris (78.4%). This figure represents the quantity of flaking debris (material <20mm) captured in the deposit and compares well to quantities and proportions obtained by experimental flaking of quartz directed by J. McNabb (see Kuman et al. 2005; see also Field 1999 for similar experiments). These experiments revealed that the mean proportion of material <20mm (maximum length) produced during the flaking of local Sterkfontein quartz was 85%. The experiment results are given below with the Oldowan data for the corresponding size categories (Table 3.2). These results vary from other experiments conducted by Schick (1987b), where she found that only 60-75% of the total assemblage flakes measured <20mm. This may be due to a number of reasons, including raw material quality, knapping intention and data capturing procedure (Kuman and Field 2008). What is evident about this assemblage and not displayed in the table above is that the quantity of quartz material under 10mm is under-represented, contributing only 9.9% of the assemblage total. In experiments on quartz by McNabb, Field and Kuman the material measuring <10mm represented 69% of the total assemblage. The quartz within the Oldowan assemblage is under-represented in the <10mm category and over-represented in the 10-19mm category. Kuman and Field suggest that the over-representation of the 10-19mm size category in quartz may be due to some transport into the cave catchment area of the good quality quartz and quartzite cobbles for use, but the primary reason must relate to the natural collecting agencies of the cave deposit (Kuman and Field 2008). A similar fate seems to have befallen the chert artefacts <10mm in size, as this category contributes only 10.3% of the chert material. Kuman and Field suggest that the remaining chert profile is nearly complete and indicates flaking occurred on site. Clarke (1994) postulated that this missing material <10mm in size may have winnowed down to the Name Chamber, which lies directly under the Oldowan deposit. The quartzites in the Oldowan assemblage only represent 2.76% of the total assemblage. The mean size of quartzite is 40 mm, and a wider range of artefact sizes is present than for quartz and chert. This suggests that quartzite was largely carried into the site after being flaked, in contrast to the paucity of quartzite <20 mm in size, which is not related to the winnowing process (Kuman and Field 2008). Only 10.3% of quartzite is 10-19 mm in size, with no artefacts measuring <10mm (*ibid.*).

Experiments Size categories	Quartz		Quartzite		Combined	
	N	%	N	%	N	%
4-9 mm	10295	69%	4631	57.6%	14926	65%
10-19 mm	2749	18%	1745	21.7%	4494	20%
20 and above	1933	13%	1670	20.8%	3603	16%
Total	14977	100%	8046	100.0%	23023	100%

Oldowan Size categories	Quartz		Quartzite		Chert			
	N	%	N	%	N	%	N	%
4-9 mm	321	10.1%	0	0.0%	24	10.3%	345	9.9%
10-19 mm	2343	74.0%	9	10.3%	175	75.4%	2527	72.5%
20 and above	504	15.9%	78	89.7%	33	14.3%	615	17.6%
Total	3168	100.0%	87	100.0%	232	100.0%	3487	100.0%

Table 3.2. Experimental Vs Oldowan assemblage size profiles excluding cores, manuports, irregularly fractured cobbles and damaged pieces (from Kuman and Field 2008).

The site formation and accumulation of the Member 5 East Oldowan Infill is deciphered from the taphonomic study of the fauna by Pickering (1999), the environmental picture assembled by Partridge's (1993) sedimentological assessment and Luyt's (2001) and Luyt and Lee-Thorp's (2003) faunal tooth isotope analysis ($C_3 + C_4$ ratios). These studies, plus the Oldowan assemblage data help to assemble the following assemblage accumulation scenario: The Oldowan assemblage was accumulated from a limited catchment area around deep shaft opening into the chamber below, indicated by the relative freshness of the artefacts, their nearly complete size profile and high proportion of faunal remains with full body parts represented, indicating a 'death trap' accumulation. The fringe woodland and naturally denser vegetation that occurs around the cave openings provided shelter for the hominids that knapped around these shafts. The proportion of C_4 eating, antelope and open grassland species from isotopic evidence (40% of sampled fauna) indicates the close proximity of drier environments (Luyt 2001; Luyt and Lee-Thorp 2003), and the high silt and clay proportions within the breccia indicates a stable, moist landscape from which sediments were deposited into the cave (Partridge 1993).

Early Acheulean

The Early Acheulean collection from Sterkfontein is much smaller than the Oldowan assemblage and derives from the Member 5 West and East breccias. The Member 5 West breccia represents the best context for the Acheulean as it has remained in place since its deposition and not been disturbed by decalcification (Kuman 2006). The Member 5 East Early Acheulean sample derives from the breccia above the Oldowan-bearing breccia. The artefacts recovered from Member 5 are certainly not the only Acheulean aged artefacts from Sterkfontein but they are the only artefacts from a provenance that is not liable to be mixed. Five handaxes have been recovered from other areas of the site, both from the superficial chert rubble above breccia and in dumps (Kuman 2006). Stiles and Partridge (1979) published several of these tools. Solution pockets have penetrated other areas of the Member 5 breccia that have yielded bifaces and artefacts but these may have been mixed with MSA (Middle Stone Age) artefacts (Kuman and Clarke 2000). These are typologically Early Acheulean artefacts but cannot be positively joined to the solid context of the Member 5 West Early Acheulean. The Early Acheulean yielding breccia of Member 5 West has also yielded fauna that has been compared closely to Lower Bed II of Olduvai Gorge, in particular an *Antidorcas recki* specimen which Vrba considered to be comparable to the Olduvai specimens and therefore dating to less than 2.0 Ma. Vrba also compares the faunal assemblage to a similar or slightly younger date than the Member 1 at Swartkrans (Vrba 1982). Faunal species profiles and carbon isotope analysis (Vrba 1975; Reed 1997; Luyt and Lee-Thorp 2003) of bovid teeth indicate that an open savannah environment existed at the time of the Member 5 West deposition. Luyt's and Luyt and Lee-Thorp's study of the C₃ + C₄ ratios has revealed that 77% of the species sampled from the Member 5 West deposit were C₄ eating, open-grassland dwelling species, in comparison to the 40% of open-grassland dwelling species (C₄ eating) sampled from the Member 5 East Oldowan deposit (Luyt 2001; Luyt and Lee-Thorp 2003). This drier habitat suggests that the Sterkfontein area was susceptible to higher rates of erosion and the cave opening may have changed, altering the catchment characteristics of the deposit (Kuman 2006).

The Early Acheulean assemblage consists of 701 pieces - 493 artefacts and 208 manuports. This assemblage has been extensively winnowed, with material <20mm representing only 4% of the assemblage and 72% represented by large artefacts like cores

and manuports (Kuman 2003, 2006). The data for the Sterkfontein Early Acheulean is presented below (Table 3.3 and Figure 3.1).

Artefact Types	Chert	Quartzite	Quartz	Total	%
Small flaking debris <20mm	-	1	18	19	2.71
Chunks <20mm	14	54	44	102	14.55
Incomplete flakes ≥20mm	2	8	23	33	4.71
Complete flakes ≥20mm	-	8	13	21	3
Retouch Pieces	-	2	1	3	0.43
Core Fragments	-	7	4	11	1.57
Flaked Flakes	-	4	1	5	0.71
Cores	9	171	78	258	36.8
Irregularly Fractured Cobble	-	21	7	28	3.99
Core tools	-	7	-	7	1
Utilised Cobbles	-	2	-	2	0.29
Manuports	21	170	17	208	29.67
Uncertain types	2	2	-	4	0.57
Total	48	447	206	701	100.00%
%	7%	64%	29%	100%	

Table 3.3. Artefact types and raw materials for the Sterkfontein Early Acheulean. (adapted from Field 1999).

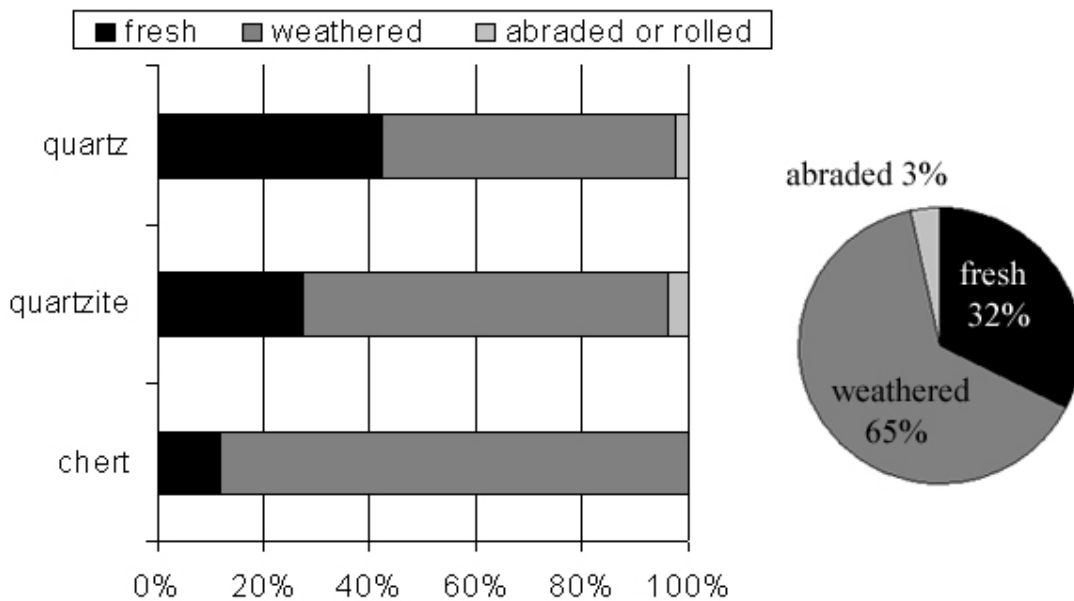

Figure 3.1. Sterkfontein Early Acheulean weathering profiles (adapted from Field 1999).

3.2. Excavation Methodology

Routine excavation techniques are often hampered when dealing with underground cave deposits. The Name Chamber is renowned for its very steep and problematic talus slope. For this reason the areas to be excavated depend on the safety of the technicians. This concern restricts organised excavation techniques to the lower and middle levels of the deposit and to areas that are easily accessed and made secure for the work. The highest levels of the Western Talus and the whole Eastern Talus cannot safely be excavated at this time. In order to excavate the Eastern Talus in the future and isolate a sample of micro-fauna, fauna and possible artefacts, considerable preliminary safety work needs to be carried out. This would, nonetheless, be a valuable exercise to clarify any difference between the eastern and western deposits and shed light on the different filtration processes at work in the feeding shaft.

The test pit excavated in 2000 was worked on during July and August of 2000. The current excavations have been undertaken in a series of 4 excavation and sieving sessions; July 10th – July 28th 2006, November 6th – November 30th 2006, February 19th – February 28th 2007 and April 5th – April 13th 2007. The excavations were limited to the Western Talus and were carried out in 30cm spits, removing large quantities of material to the sieves for processing outside the caves. This is not an ideal technique but a necessary one given the difficulty of excavating on the talus slope and the need to carry sediment through underground tunnels and chambers to the surface. Sieving was carried out meticulously using 2mm mesh sieves and wet and dry methods and supervised by myself in order to extract all microfauna and flaking debris. Figure 3.2 presents the squares excavated in the Name Chamber. The relationship these squares have to the deposits is discussed in Chapter 4. For my analysis I have divided the squares into four main excavations, Excavation 1 (Ex1) to Excavation 4 (Ex4). The letters of the excavation grid correspond to the order in which the squares were opened on the talus slope. Excavations moved around the talus slope as preparatory safety work was completed. Excavation 1 is the largest of the excavations and the lowest on the western talus (10 m below the base of the feeding shaft). Ex1 consists of the squares D, C, J, P, Q, A, B, R, F and G. Excavation 2 (Ex2) is directly above Ex1 and consists of the squares I, H and E and lies 8m below the base of the feeding shaft. Excavation 3 (Ex3) is the smallest of the excavations and consists of squares L and K and lies 6m below the base of the feeding shaft. The final excavation

(Ex4) is the highest (3m below the base of the feeding shaft) on the Western Talus and consists of the remaining squares M, N and O. See Figure 5.11 for a presentation of the stratigraphic profile of the western talus including the placement of the excavations. Sediments from the steps cut into the Western Talus to access the excavation were also sieved and analysed. A sample was also excavated from the base of the Western Talus, just above the old tourist path. This test pit lies 28m below the base of the feeding shaft.

The depths of the excavations were measured in relation to the surface of the talus (e.g. square A, spit 0-30cm). The positions of the excavations and key geological points within the Name Chamber were plotted in relation to a datum set up in the Name Chamber at the same point measured by Clarke at the bottom of the shaft and immediately above the talus summit, during his 1994 exploration. The feeding shaft was measured to be 12.5m deep from the floor of the surface excavation in the Oldowan infill. The excavation floor was recorded as 11m below the surface excavation datum (Clarke 1994). The feeding shaft opens to surface grid square R/57 in the main excavation. A presentation of this and the subterranean outline of the Name Chamber talus deposits can be seen in Figure 5.10. All the excavations are placed on the Western Talus, which, like the Eastern Talus, runs in a north-south slope from the feeding shaft on the far northern face of the chamber. The Far Western Talus deposits lie in a north-south westerly direction from the feeding shaft into the south-eastern corner of the Milner Hall. Figures 3.3, 3.4, 3.5, 3.6 and 3.7 represent the 4 excavations in the Western Talus. The measurements are all accurate; the schematics, however, are not to scale. Figure 3.3 presents a key to all 4 excavation schematics.

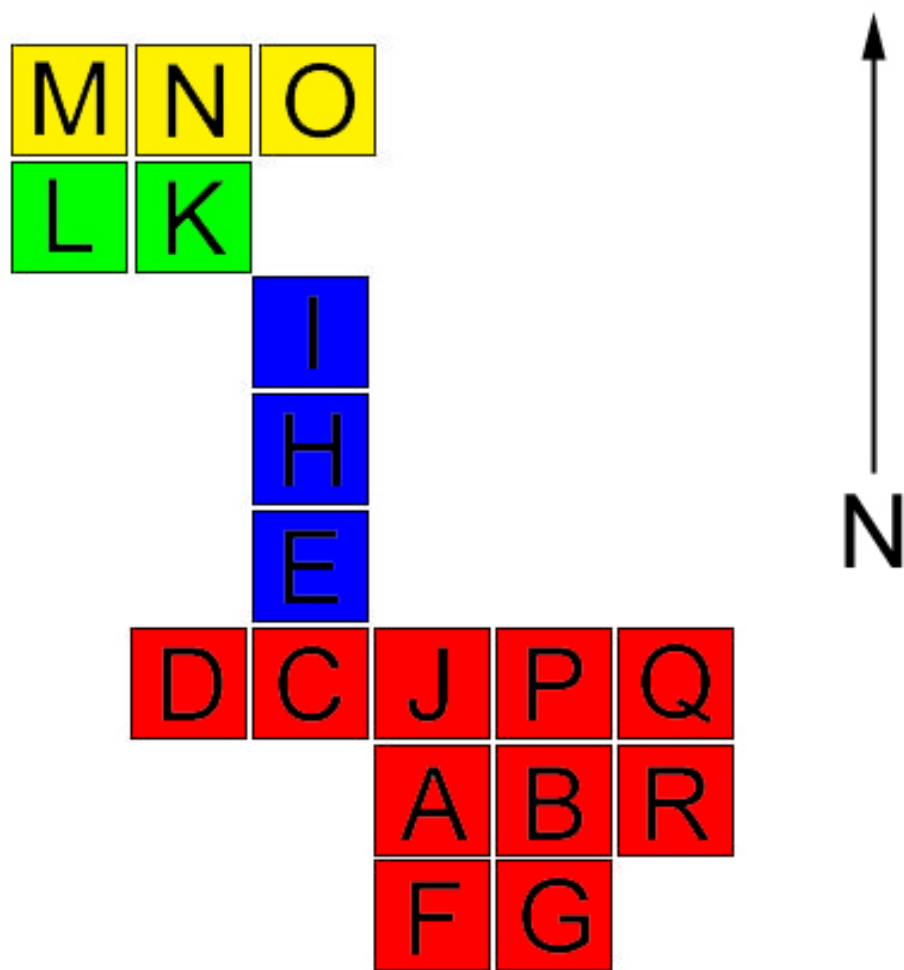

Figure 3.2. Name Chamber excavation squares. The plan is orientated north to south corresponding to the actual excavations. Ex1 = Red, Ex2 = Blue, Ex3 = Green, Ex4 = Yellow.



Figure 3.3. Key to excavation schematics presented below.

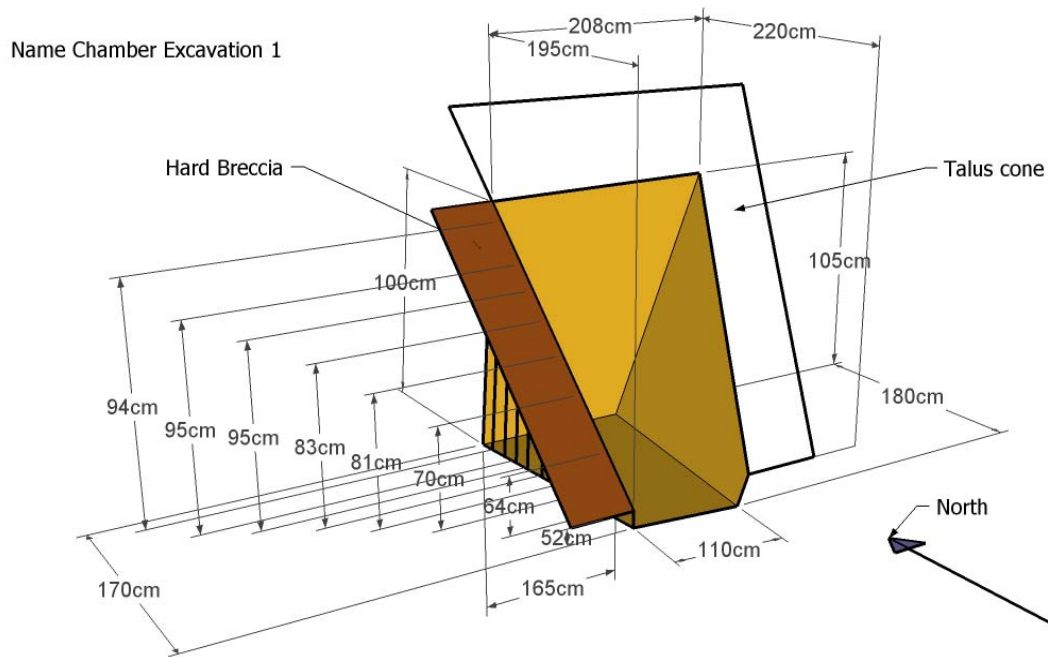

Figure 3.4. Schematic of Name Chamber excavation 1. The hard breccia deposits were not excavated during this research.

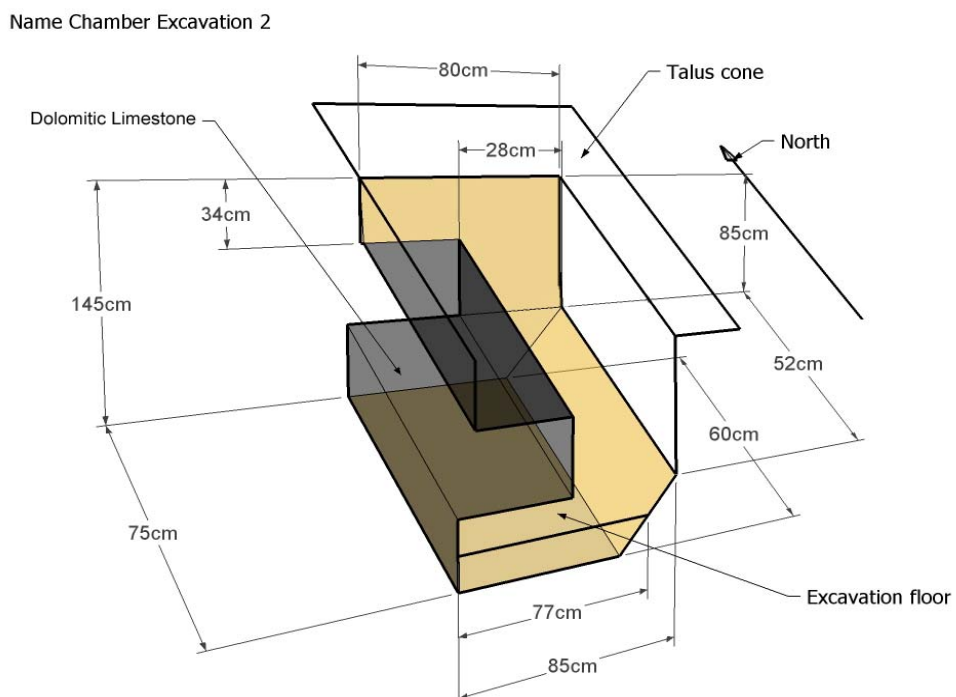

Figure 3.5. Schematic of Name Chamber excavation 2.

Name Chamber Excavation 3

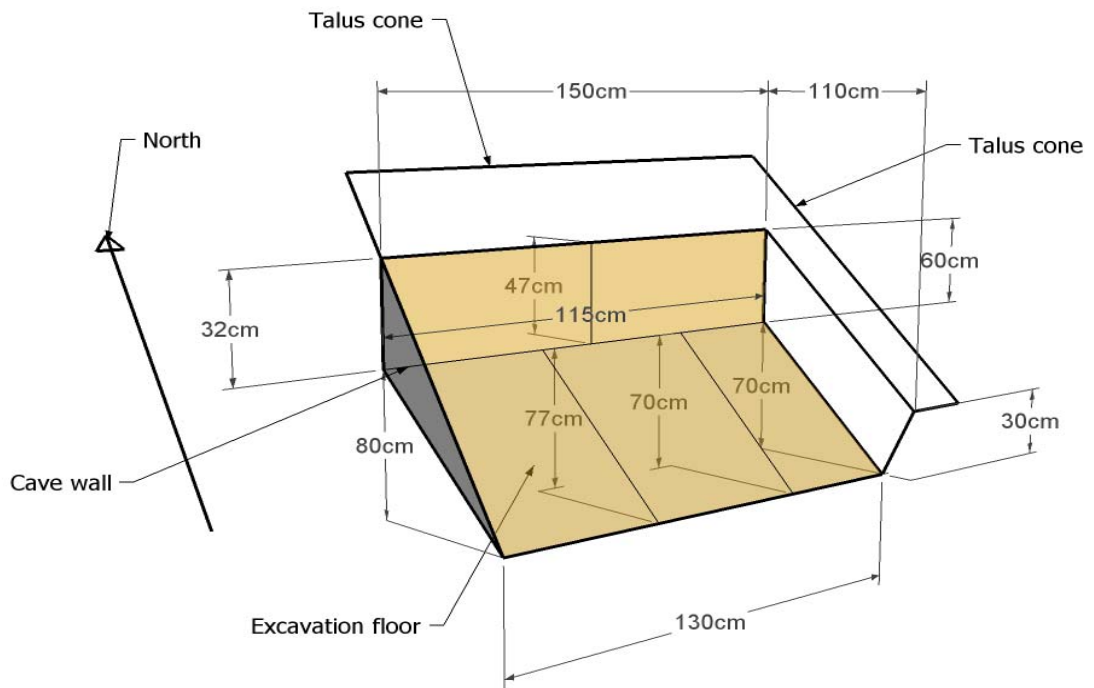

Figure 3.6. Schematic of Name Chamber excavation 3.

Name Chamber Excavation 4

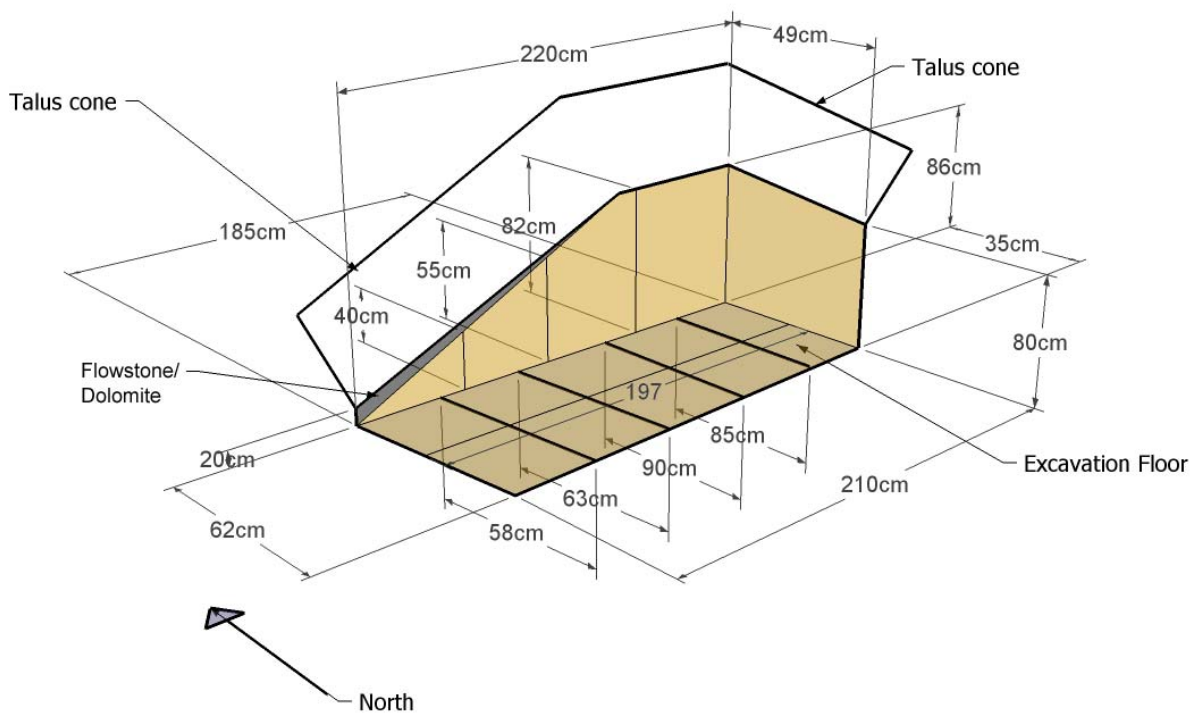

Figure 3.7. Schematic of Name Chamber excavation 4.

3.3. Lithic Analysis Methodology

Lithic analysis revolves around the typology and technological attributes (measurement and interpretation) of the stone tools and their bi-products in their relative proportions (Andrefsky 2005). The meticulous examination of different artefact attributes and the proportions of recognised components of an assemblage provides the evidence for technological classification and site formation factors, including natural and hominid influence on assemblage characteristics. In section 3.3.1 I outline the key attributes of stone tools and how they are measured. In section 3.3.2 I discuss the assemblage components and the inferences that can be made from their proportions within an assemblage.

All of the artefact types discussed in section 3.3.2 are subject to different proportions within an assemblage due to raw material selection, properties, knapping abilities, environmental influences and deliberate artefact transport. Differences in raw material utilisation and knapping characteristics can be seen between the Oldowan and Acheulean at Sterkfontein (Kuman 2003). These differences create different component proportions within the assemblage and may also suggest different levels of competence in knapping. The tables and figures presented in Section 3.1 show the assemblage profiles of the Oldowan and Early Acheulean collections from Member 5 Sterkfontein.

These components will also all be subject to weathering, the level of which is dependant on the raw material in question and the length of time that the artefacts are exposed to environmental and biological factors both before and during the burial of the assemblage. Each raw material will react to weathering in different ways and at different rates. Quartz is the hardest of the raw materials used and although it shatters easily, it is very resistant to most natural weathering processes. Quartz-based assemblages frequently contain high proportions of fresh material, and when weathered quartz is encountered it has undergone exposure to abrasive elements. Quartzites and cherts weather more easily. The weathering rate of these materials depends on the composition of the deposit in which they lie and for quartzites on its degree of consolidation. In unconsolidated deposits quartzites and cherts will weather more quickly than in consolidated hard breccias. It also stands to reason that different components of the same assemblage can show different levels of weathering due to different exposure times. The artefact condition of the

Oldowan and Acheulean assemblages have been assessed visually and published in Field (1999) and illustrated in the tables and figures in Section 3.1.

3.3.1 Standard lithic analysis

When analysing an artefact assemblage there are attributes of the assemblage that need to be recorded and measured in a standard fashion. I have followed the artefact analysis techniques of Field (1999), as this provides the most up to date system used for the Sterkfontein assemblages and allows for systematic comparison of the Sterkfontein valley assemblages, which are made in the same raw materials. Presented below are the attributes found. Certain features are generic and can be measured on all artefacts. Other features are specific to the tool types listed in section 3.3.2.

Generic Artefact Attributes

Raw Material type:	Quartz, Quartzite or Chert
Condition:	Fresh, Weathered, Very Weathered, Slightly Abraded, Abraded, Rolled or Trampled.
Retouch:	None, Dorsal face, Ventral face, Bifacial and area of the flake affected by the retouch i.e. Distal, Lateral, Tip, Platform.
Utilisation:	None, Dorsal, Ventral, Bifacial.
Blank Type:	River Cobble, River Pebble, Hillslope Cobble, Vein Quartz, Unknown.
Artefact Type:	See section 3.3.2 for typologies.
Cortex Quantity:	0 = 0% cortex, 1 = <25% cortex, 2 = 25-50% cortex, 3 = 51-75%, 4 = >75% cortex.
Battering:	0 = No battering, 1 = Battering in one or two areas, 2 = Battering over large areas.
Dimensions (mm):	Maximum length, width and thickness.

Manganese Staining: 1 = 0-25% cover, 2 = 25-75% cover, 3 = 75-100% cover.

Flake Attributes

Complete flake: A flake with intact platform, point of percussion, lateral edges, and distal termination.

Incomplete flake: A flake with intact platform, point of percussion, lateral edges and missing distal termination.

Flake fragment: A portion of a flake with possible missing lateral edges, distal termination, platform and point of percussion.

Cortex position: In accordance with Toth (1982).

1 = cortical butt and dorsal,

2 = cortical butt and partly cortical dorsal,

3 = cortical butt and non-cortical dorsal,

4 = non-cortical butt and cortical dorsal,

5 = non-cortical butt and partly cortical dorsal,

6 = non-cortical butt and dorsal.

Number of striking platform facets: Number of facets exhibited on the striking platform.

Dorsal scar number: Number of flake scars exhibited on the dorsal face of the flake.

Dorsal scar length: The maximum length of the largest dorsal scar on the flake.

Dorsal scar pattern: Unidirectional, Unidirectional and Transverse, Transverse, Transverse and Opposed, Unidirectional and Opposed, Opposed, Radial, Irregular, Not possible to record.

Striking Platform

Ventral angle:	The angle measured between the platform and the ventral surface of the flake at the central point of the platform.
Dorsal angle:	The angle measured between the platform and the dorsal surface of the flake at the central point of the platform.
Terminations:	Feathered, Stepped, Hinged or Overshoot.
Minor Breaks:	Single, Double or Multiple breaks.

Core Attributes

Flake scar number:	Number of flake scars exhibited on the core.
Flake scar length:	The maximum length of the largest scar on the core.
Number of platforms:	The number of directions (or platforms) from which a core has been flaked. Unifacial Cores are flaked along one platform utilising one face of the stone. Bifacial cores are flaked along a two platforms utilising opposing faces of the stone, and Polyhedral Cores are flaked using three or more platforms.
Reduction stage:	1 = Fully reduced, no further possible platforms for removals. 2 = Nearly fully reduced, one or two platforms remaining for flaking. 3 = Nominally reduced, more than two platforms remaining for further flaking leading to possible raw material quality issues resulting in the discard of the core.
Volume:	Maximum length \times width \times thickness.
Elongation Ratio:	Maximum length \div maximum width. This number is used for the comparison of biface shape.

Manuports

Weight:	Measured in grams.
Volume:	Maximum length \times width \times thickness.
Provenance:	River cobble, River pebble, Hillside Cobble, Unknown.

3.3.2. Lithic Typology: definitions and interpretations

Below I discuss the different components that make up a lithic assemblage, how they have been analysed in this research and how the relative proportions and features within these components and the assemblage can be interpreted.

Flaking Debris: *Chunks or Flakes <20mm in maximum length*. Each small flaking debris specimen has to show at least one diagnostic feature of deliberately chipped stone. In Sullivan and Rozen's work (1985) small flaking debris is defined as pieces missing a Single Interior Surface, point of percussion and margins. The drawback of this definition is it relies on all raw materials being brought into the site, all debitage forming a foreign component in the sediment. This is not the case in Sterkfontein assemblages which include chert and vein quartz. These raw materials are found naturally in and around the Sterkfontein caves. More care is then needed when analysing small flaking debris and diagnostic features must be present in order to reduce misclassification. The proportion of debris found *in situ* provides evidence of natural winnowing effects on the assemblage before it was buried, or changes to the assemblage due to disturbance or re-working. Exact proportions of debris differ with the raw material utilised. Experimental knapping has provided mean proportions of artefact size categories produced through the knapping of different raw materials. Kuman and Field (2008) and Kuman et al. (2005) have produced experimental collections that provide templates for the proportions of different size categories in assemblages produced from the local Sterkfontein raw materials. In Kuman and Field's experiments, the small flaking debris produced during knapping ranges from 72% for quartzite to 87% for quartz. The proportions of debris are useful when assessing the extent of natural post-depositional erosion as small flaking debris is the first artefact

category to be moved from an area by natural processes. By identifying missing elements in an assemblage one can gauge the contextual integrity of the collection. In the analysis of the debris in the Name Chamber assemblage there are certain restrictions that preclude some analytical methods. As discussed in the literature review, the Sullivan and Rozen technique (SRT) has drawbacks when dealing with brittle raw materials (Prentiss 1998), as is the case with the Sterkfontein quartz dominated assemblage. I have taken the suggestion of Prentiss (1998) and used assemblage size profile through different artefact size classes as an assemblage variable. I have followed the SRT in that I have used flake categories that are not technologically misleading due to terminology and used the proportions of these flake types as points of comparison within the size categories and through the assemblages. I have then followed the MRST (modified Sullivan and Rozen technique) and included flake size profiles within artefact size classes as a comparative assemblage variable.

Flakes: *Flake fragments, incomplete flakes and complete flakes measuring $\geq 20\text{mm}$ in maximum length.* Whole flakes possess all the features endemic to the flaking process i.e. striking platform, bulb of percussion, lateral edges and distal ends. The flakes finish at the distal end with a feathered, stepped, hinged or overshoot termination. The size, quantity and completeness of flakes may provide evidence of knapping capabilities and intention of tool production. Incomplete flakes provide us with only a medial and proximal section of the flake but may disclose the same information. The scars preserved on the dorsal face of the flake can provide similar information. Flake scars with step terminations, coupled with a high proportion of incomplete or flake fragments within the assemblage, suggest difficulties encountered with the raw material, generally poor or brittle raw materials or poor knapping. Conversely high numbers of flake scars with feather terminations coupled with large proportions of complete flakes indicate good quality raw materials or highly skilled knapping. Numbers of flake scars can be used to indicate degree of core reduction. Successive reduction stages produce flakes with increasing numbers of flake scars until the whole dorsal face is covered in scars. The quantity of cortex remaining on a complete flake platform and dorsal face has been used by Toth (1985) and Villa (1983) to indicate reduction stage.

Cores: Pieces that have been intentionally struck using hard or soft hammer freehand percussion, hammer and anvil (bipolar) percussion or pressure techniques in order to produce flakes. The different types of core attest to the different reduction strategies and intentions of the knapper. Different flaking requirements and knapper abilities produce different shaped cores with classifiable characteristics. The following cores form the basic core types produced during the Oldowan and Acheulean and exhibit different technological goals with their shapes and flaking organisation.

Casual cores: Cores usually defined as cores with one or two removals. However, in this thesis casual cores are defined as cores with a casual flaking strategy that utilises the advantageous natural shape of the raw material, including cores that have more than two removals but that are still minimally flaked. Casual flaking indicates an opportunistic use of raw materials while practicing an expedient technology. A single removal may be followed by the utilisation of a new platform on the opposite face, forming a bifacial flaking pattern along the side or an elongated tip of a cobble. Such pieces have traditionally been called chopper cores if they have more than two removals. In this study, cores are termed casual because there is more tendency towards a unifacial and sub-radial pattern, and this is significant for artefact classification purposes. In Field, the definition of a 'chopper core' is "pieces unifacially or bifacially flaked along just one edge of a cobble...the focus [of reduction] is on one edge of a cobble" (1999: 224). This classification of 'chopper core' is restrictive for technological analysis given that several cores in the Dump 21 collection display minimal, casual reduction strategies but have more than two flake scars that show no concentration on a single core edge. Under Field's classification this would remove these cores from the casual core category and yet not fit them into another core type category. Therefore, in this research irregularly flaked cores with fewer than six scars flaked in a bifacial or unifacial fashion and utilising fewer than three platforms have been grouped as casual cores in an attempt to bring together cores of similar reduction strategy but with more flake scars than Field allowed in the casual core category. In order to allow for a comparison of data sets, I have adapted Field's data for the Early Acheulean assemblage to this classification.

Chopper cores: Cores flaked unifacially or bifacially along just one edge of a cobble. Occasionally an opportunistic removal will have been taken from the other side of the core but the focus is on one edge of the core. Following Field (1999) the chopper core

shows similar form to the “chopper” but with no evidence of utilisation. The diagnostic feature of the chopper core is the intentional focus of flaking on one portion of the cobble which creates an edge that may be suitable for utilisation.

Polyhedral cores: Cores utilised for the production of flakes from different platforms. Polyhedral cores exhibit three or more platforms utilised during knapping and a largely random flaking pattern in order to opportunistically utilise platforms and raw material shape. These cores often display highly variable flake scar dimensions and termination scars.

Discoidal cores: Cores that are flaked bifacially using a centripetal flaking organisation. Discoidal cores can produce flakes of a more regular shape and size and may display an intention to produce flakes in a more efficient manner utilising a greater volume of the core for flaking. The bifacial flaking pattern supports the maintenance of the platform on both faces of the core leading to the whole or majority of the circumference of the piece being utilised.

Single platform cores: Cores that have been flaked using a single flaking platform. This reduction strategy usually utilises a naturally or deliberately split cobble or flat core surface from a flake removal as a platform from which to remove flakes.

Formal Tools: *Pieces of varying size that exhibit flaking for the purpose of retouch or shaping as well as flake production and/or utilisation.* Two types of heavy-duty tools are recognised: large flake-tools and core-tools. Heavy-Duty tools are large flakes that are unifacially or bifacially retouched, or show shaping flake scars, often in the form of side-struck flakes. They often show utilisation along one or more edges. Examples are handaxes and cleavers produced on flake blanks or cobbles. Core-tools may include pieces that have been used for flake production and subsequently utilised along the flaked edge, e.g. choppers.

Utilised cobbles: *Unflaked pieces, modified through utilisation, usually in the form of battering*. They can be easily wielded cobbles that can be used as missiles or hammerstones, or heavy cobbles and boulders used as anvils. Utilised cobbles show no modification prior to use, but must show utilisation damage to differentiate them from manuports. The larger dimension and greater quantity of these heavy duty tools are good diagnostic indicators of the Early Acheulean technology.

Production of refined heavy duty tools requires forethought. During the Oldowan, utilised unifacial, bifacial and casual cores are less common and provide the majority of modified heavy-duty tools and are often termed 'chopper cores'.

During the Acheulean, greater knapping skill and more focussed knapping intention enables large heavy duty tools to be produced from boulders, larger cobbles and large flakes (>100mm). These larger blanks are then retouched or shaped bifacially to create handaxes, cleavers, picks, or heavy duty scrapers.

Manuports: *Pieces that are brought to the knapping site for later use*. They show no modification or utilisation. Manuports differ in raw material type, quality and dimensions.

Chapter 4. Dump 21 Analysis and Results

Introduction

Dump 21 (D21), was only recently discovered by I. Makhele (site foreman) in an overgrown corner of the Sterkfontein main excavation site. The dump was fully excavated and sieved two years ago, producing a sample of artefacts and natural pieces from decalcified breccias that were divorced from their context by the lime workers over seventy years ago. Twenty other dumps created by the lime workers were excavated at Sterkfontein during the 1960's (Tobias and Hughes 1969). Stiles and Partridge (1979) later published an assessment of the artefacts from these dumps, together with all other artefacts retrieved at that time from breccia and from the overlying 'residue' or overburden on top of the Member 5 and 6 breccias. Figure 4.1 shows the original map of the Sterkfontein site including the dumps found and excavated up through 1979. The newly discovered Dump 21 lies 6m west and 4m south of Robinson's Extension Site, which is now included in Member 5 West. It was previously missed because the dump lies at a further distance from the excavation than has been previously experienced. Figure 4.2 shows the Sterkfontein site with the location of Dump 21 indicated. The excavation grid has been extended to cover the dump. Note how far the dump is away from the original excavation in comparison to the other dump locations. It should also be noted that Dump 21 was found in an area of much denser vegetation which also contributed to its comparatively recent discovery. It seems likely that this area has always been of denser vegetation given its distance from the site and rocky terrain.

Contextually the Dump 21 material is difficult to define. The material within the dump was removed from its original secondary context within the cave breccia or decalcified sediments by the lime workers and dumped. The lime workers started their work at Sterkfontein in the late 19th century, but they were most active during the 1920's and 1930's. Hence the dump may have been exposed to weathering conditions on the surface for up to a century. Any breccia still adhering to artefacts is not fresh but in the process of decalcification. This suggests that the assemblage originated from what was once solid breccia but was in a decalcified state when moved by the lime miners. With no way of tracing any type of provenance or source through adhering breccia, the artefacts need to be analysed carefully before they can be attributed to a specific technology. Only

by comparisons with current collections from stronger contexts within the Sterkfontein assemblage can this collection be classified. Firstly however the Dump 21 assemblage needs to be classified and analysed in isolation before comparisons can be made.

4.1. Assemblage Overview

The Dump 21 assemblage originally consisted of 84 pieces. Of these 84, 34 pieces are artefacts and one is a manuport. The remaining 49 pieces were naturally broken dolomitic limestone from the cave system. No breccia was recovered from the dump, and this suggests the material was mined from decalcified sediment. Within the collected artefacts from the dump, none of the pieces measured less than 34mm (maximum length) and the mean artefact size is 84mm (maximum length). The mean flake size is 62mm, the largest measuring 101mm, and the mean core size 91mm, the largest measuring 162mm with a mean volume of 373cm³. If the smaller debris was not lost in the transport by the lime workers to the dump, then it may be presumed that any smaller pieces were winnowed from the assemblage before it was incorporated in the breccia, or during the last 70 years of exposure on the surface. The assemblage is dominated by cores (26 of the 35 pieces; 74%). The other eight artefacts are flakes (23%), with only one manuport amongst the artefacts. The Dump 21 handaxe will be discussed separately in section 4.5. Table 4.1 presents the Dump 21 assemblage data.

Artefact Types	Chert	Quartzite	Quartz	Total	%
Small flaking debris <20mm	-	-	-	-	-
Incomplete flakes ≥20mm	-	1	-	1	3%
Complete flakes ≥20mm	1	4	-	5	15%
Core Maintenance Flakes	-	2	-	2	5%
Flaked Flakes	-	-	-	-	-
Cores	-	25	-	25	71%
Irregularly Fractured Cobble	-	-	-	-	-
Core tools	-	1	-	1	3%
Utilised Cobbles	-	-	-	-	-
Manuports	-	1	-	1	3%
Total	1	34	-	35	100.00%
%	3%	97%	-	100%	

Table 4.1. Artefact types and raw materials for the Dump 21 assemblage.

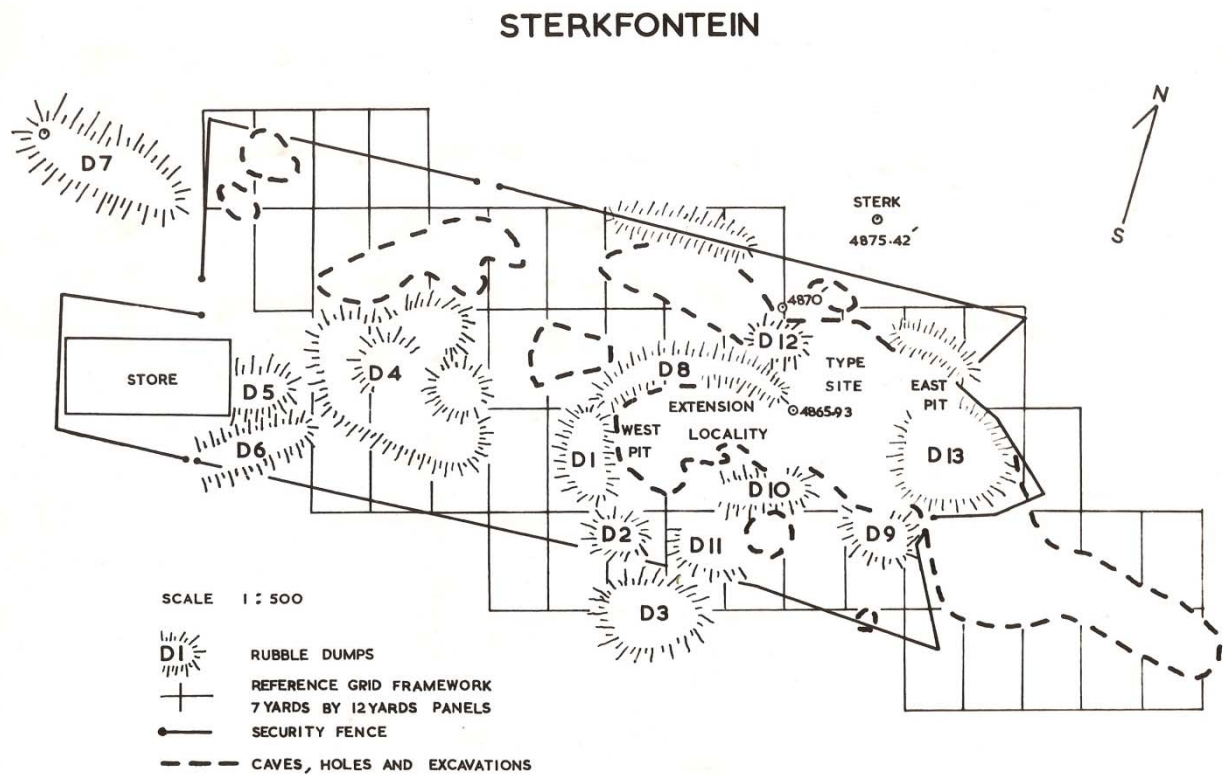

Figure 4.1. Sterkfontein and lime worker's dumps (Stiles & Partridge 1979)



Figure 4.2. Sterkfontein site including Dump 21 location (adapted from Kuman and Clarke 2000).

4.2. Raw Material Use and Selection

During the Early Acheulean at Sterkfontein we see an increased use of quartzites collected from the nearby river gravels 300 to 500 meters away. These quartzites take the form of river cobbles of various shapes and sizes. As the source of the Blaaubank River is only 24km away from Sterkfontein, the shape and condition of the cobbles are varied due to the short distances traveled and reduced exposure to processes of abrasion (Kuman 1994b). This increased use of quartzites over quartz in the Early Acheulean indicates a preference for the less brittle, more manageable raw materials. Larger flakes, less shatter and increased edge durability of quartzite over quartz are amongst the advantages of using finer grained raw materials.

Unfortunately when dealing with a dump assemblage there are several assumptions one needs to make in order to be able to make inferences about the assemblage composition. Firstly, that all raw materials of similar sizes are susceptible to the same natural processes of erosion i.e. quartz or chert pieces are not more susceptible to winnowing and natural movement than quartzite pieces of similar size. Secondly, that the dump material was transported from its original context without any process of selectivity. Thirdly, that some material may have been lost during the transport from the original context to the dump site. Once comfortable with these assumptions it can be assumed that the raw material profile is closely comparable to when the dump was created, and that the dump would contain a comparable raw material profile as its parent assemblage. The absence of quartz is due to the small sample size.

In the Dump 21 assemblage we see the dominance of quartzite and a complete lack of quartz, which is unlike the Member 5 West assemblage with 29% quartz Field (1999). However, there are only 35 pieces in the Dump 21 sample, which is too few for accurate comparison. The only other contributing raw material found in the dump is a single chert flake. All quartzite artefacts at Sterkfontein are made on cobbles collected from the river gravels and brought up to the Sterkfontein site, as quartzite is only found in terrace deposits (Kuman 1996). A degree of variation in the type of cortex covering the external surface of the artefacts can be seen within the assemblage, varying from heavily pitted to smooth. This mixture demonstrates the variation in the hardness (or consolidation) of the various quartz cobbles in the gravel, as well as variable exposure to processes of erosion and abrasion in the river system. Of the flakes, only one artefact has cortex remaining and

it is of the smooth variety. Of the 26 cores, three have no remaining cortex (11.5%). Another three cores have heavily pitted cortex (11.5%) and the remaining 20 cores (77%) have smooth cortex. The manuport also has a smooth cortex surface. There appears to be a strong correlation between type of cortex and fineness of grain (personal observation). Cobbles with a smoother cortex have finer grained interiors. With the dominance of artefacts with smooth cortex one can suggest that before any flaking had been practiced these smoother, finer grained quartzites were selected over the cobbles with rough cortex and correspondingly coarse grains.

In total, the assemblage raw material profile clearly favours the finer grained quartzites for artefact manufacture. Including the flakes, the number of artefacts made from coarse grained quartzites number only three (11.5%), supporting the evidence that finer grained quartzites (88.5%) were recognised from their cortex and specifically sought within the river gravels for their superior flaking properties.

4.3. Typology

Typological classification is an integral part of any archaeological analysis. The accurate classification of artefacts allows comparisons with other assemblages from any other site. The specific features of each artefact type are discussed in the methods section. Below (Table 4.2), the Dump 21 artefacts are presented as they have been typologically classified. These classifications are based upon the core reduction techniques and shapes of the discarded core or flake. Figures 4.3 and 4.4 present the proportions of these artefacts within the assemblage.

Flakes	
Complete Flakes ($\geq 20\text{mm}$)	5
Incomplete Flakes ($\geq 20\text{mm}$)	1
Core Trimming Flake	1
Core Rejuvenation Flake	1
Cores	
Polyhedral Cores	15
Casually Flaked Cores	7
Incomplete Discoidal Cores	2
Discoidal Cores	1
Handaxes	1
Natural Stone (Manuports)	1

Table 4.2. Dump 21 artefact typologies.

4.3.1. Dump 21 Core Types

As one can see from the above table (Table 4.2), and Figure 4.3 the majority of cores (15 out of 26, 57%) are classified as polyhedrons based on their multiple platform use (more than three) and random flaking pattern. Table 4.3, below, provides the technological details of these cores. Polyhedral cores are regarded as the result of an unorganised flaking pattern, with an opportunistic use of the available edges of a cobble. By switching the core's platforms frequently, the hominids that made the Dump 21 cores removed a large number of smaller flakes (mean maximum flake scar length of 52mm) without the need for platform or core maintenance. The number of remaining platforms at time of discard on the polyhedral cores suggests an expedient nature of flake production and raw material use that led to the manufacture of these cores. Illustrations of the cores are presented at the end of the chapter in Figures 4.21 through to 4.28.

Art Number	L (mm)	W (mm)	T (mm)	Vol (cm ³)	No. Flake Scars	Max scar length (mm)	No. Step Term	Remaining platforms	% cortex cover
1194	107	80	61	522	7	56	3	2	50-75
1193	126	78	44	432	11	61	2	1	25-50
1173	88	82	71	512	8	34	4	1	25-50
1195	88	64	43	242	6	63	2	1	50-75
1190	76	68	46	238	5	51	0	1	25-50
1007	90	70	83	523	9	47	2	3	50-75
1175	90	90	82	664	14	59	2	3	0-25
1001	89	72	46	295	10	51	2	1	0-25
1168	95	85	51	412	16	75	0	0	25-50
1165	88	73	62	398	15	44	3	0	0-25
1191	60	45	46	124	11	39	1	2	0-25
1181	95	87	62	512	8	74	0	3	25-50
1172	77	52	53	212	6	44	1	1	25-50
1003	68	67	47	214	6	40	2	2	25-50
1179	71	37	42	110	11	46	1	1	0-25
Mean	87	70	56	361	9 ¹	52	2 ^{1,2}	1 ^{1,2}	25-50 ^{1,2}

Table 4.3. Details for the Dump 21 polyhedral cores. Note that artefact 1190 has only 5 flake scars but is classified as a polyhedral core due to the utilization of three platforms during flaking. . ¹ Median. ² Mode. See footnote below ².

Casually flaked cores are the next largest group in the assemblage. The casually flaked cores include the casual core as defined by Clark (1970) and irregularly flaked core with few removals (under 5). Table 4.4 presents the details of the casual cores. Seven of the 26 Dump 21 cores (26%) are classified as casual because of their low flake count, low number of platforms utilised and random flaking pattern. Casual cores are also regarded as largely a result of expedient use of raw material and opportunistic flake needs. On a casual core only a small number of flakes are removed before the piece is discarded. The mean number of flake scars on the casual cores numbers three. Below are the data for the Dump 21 casual cores.

² Measurements of central tendency: Where interval-type measurements have been made (e.g. lengths measured in mm), the arithmetic mean has been calculated. For all other ordinal data (e.g. number of flake scars, number of residual platforms) both the median (the middle data point of the sorted list of points) and the mode (the most frequently occurring value) have been calculated. Comment is included if these two values are different.

Art Number	L (mm)	W (mm)	T (mm)	Vol (cm ³)	No. Flake Scars	Max scar length (mm)	No. Step Term	Remaining platforms	% cortex cover
1174	80	74	63	373	4	66	0	0	50-75
1166	91	82	50	373	1	46	0	0	75-100
1171	95	65	40	247	4	27	2	2	0-25
1205	59	47	36	100	2	32	0	2	25-50
1180	87	60	39	204	3	36	0	1	25-50
1177	90	77	50	347	5	41	0	1	50-75
1004	86	64	39	215	1	63	0	0	0-25
Mean	84	67	45	265	3 ¹	44	0 ²	1 ²	25-50 ¹

Table 4.4. Details for the Dump 21 casually flaked cores. ¹ Median. ² Mode.

Radially flaked cores form the next category of the Dump 21 core types (number of discoids and partial discoids = 3, 11%). Table 4.5 presents the technological data for the radially flaked cores. The systematic bifacial flaking of a core around its circumference in a centripetal fashion results in the formation of a discoidal core or discoid. By utilising portions or the entire circumference of the piece one can produce a greater number of similarly shaped flakes. The mean number of flake scars on the discoidal cores is 14. This reduction technique requires time and precision percussion as the flakes cannot be too intrusive or the platform will be ruined. Discoids and Partial (or Incomplete) Discoids are both represented in the Dump 21 assemblage, and as these core types result from the same reduction strategy, they have been grouped together.

Art Number	L (mm)	W (mm)	T (mm)	Vol (cm ³)	No. Flake Scars	Max scar length (mm)	No. Step Term	Remaining platforms	% cortex cover	Specific Type
1164	162	132	53	1,133	13	92	0	3	25-50	Incomplete discoid
1000	112	79	69	611	15	51	3	2	0-25	Incomplete discoid
1005	85	70	57	339	16	34	3	2	0-25	Discoid
Mean	124	94	60	694	15 ¹	59	3 ^{1,2}	2 ^{1,2}	0-25 ^{1,2}	

Table 4.5. Details for the Dump 21 radially flaked cores. ¹ Median. ² Mode.

■ Polyhedral
 ■ Casually flaked
 ■ Incomplete Discoid
 ■ Discoidal

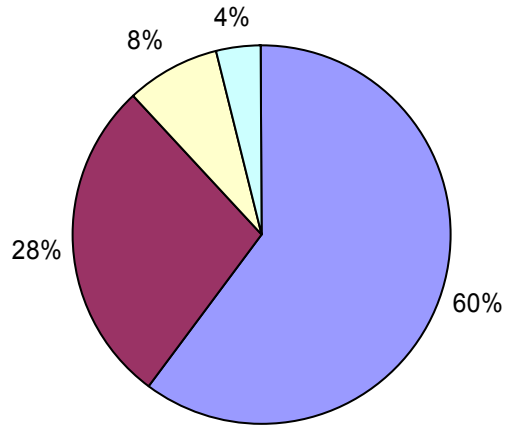

Figure 4.3. Dump 21 core types.

■ Polyhedron
 ■ Casual
 ■ Incomplete Discoid
■ Complete flake
 ■ Incomplete flake
 ■ Core trimming flake
■ Core rejuvenation flake
■ Core Tool

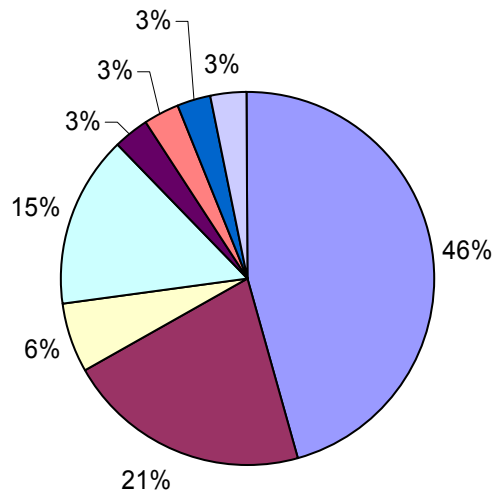

Figure 4.4. Dump 21 artefact composition.

4.3.2. Dump 21 Flake Types

There are three different types of flake represented in the Dump 21 assemblage. The complete flakes, incomplete flakes and flake fragments have been grouped together in the first category because they represent the same intention by the knapper - to remove a workable flake with a sharp edge. Whether the flake is complete or broken is not important when considering the intention of the tool manufacturer. It should be noted that all of the Dump 21 flakes have only one striking platform facet. Due to the poor weathering condition of the flakes it is impossible to tell if any cortex is remaining on the striking platform.

Art Number	L (mm)	W (mm)	T (mm)	No. Dorsal Scars	length max scar (mm)	No. Step Term	% cortex cover	Specific Type
1162/1/2	101	59	36	0	0	0	50-75	Flake Incomplete
1204	60	32	8	0	0	0	0-25	Flake
1200	34	34	6	4	30	0	0-25	Flake
1182	52	40	17	6	36	0	0-25	Flake
1167	89	50	16	2	84	0	0-25	Flake
1197	60	49	15	3	34	0	0-25	Flake

Table 4.6. Details for the Dump 21 complete, incomplete flakes and flake fragments. Note on flakes that have dorsal flake scars, all flake scars have feather terminations.

The remaining two flake types are more interesting because they represent an intention by the knapper to modify and repair a raw material flaw or knapping mistake, or to continue utilising the same core. The data for the core rejuvenation flake is given below (Table 4.7) followed by the data for the core trimming flake (Table 4.8). This intention illustrates more intense raw material exploitation and requires more time and attention on the part on the knapper than the data for the Dump 21 cores suggests. Both of these flakes suggest some planned reduction strategy and an understanding of methods of core maintenance and repair. Note the number of step or hinge terminations on the dorsal flake scars illustrating the need for this knapping strategy and resulting in the production of this core rejuvenation flake. The core trimming flake represents a similar intention by the knapper as the production of the core rejuvenation flake. The core trimming flake differs

in that the platform is not rejuvenated as is the goal of the core rejuvenation flake. The intention behind the core trimming flake is to help shape the core for future reduction, be that in aid of a future platform or to aid the removal of a flake

Art Number	L (mm)	W (mm)	T (mm)	No. Flake Scars	length max scar (mm)	No. Step Term	Remaining platforms	% cortex cover
1183	42	53	22	6	21	2	0	0-25

Table 4.7. Details for the Dump 21 core rejuvenation flake.

Art Number	L (mm)	W (mm)	T (mm)	No. Flake Scars	length max scar (mm)	No. Step Term	Remaining platforms	% cortex cover
1198	60	24	9	2	55	0	0	0-25

Table 4.8. Artefact data for the Dump 21 core trimming flake.

4.4. Core Reduction and Flaking Patterns

4.4.1. Cores

The reduction of cores and the flaking patterns evident on discarded cores have been recognised as an indicator of curation and knapping skills among all stone-age cultures. Theory has changed somewhat from the typological classification of cores for comparison between assemblages to a more technological approach. By studying the flaking features, patterns and core reduction techniques and utilising a *chaîne opératoire* approach more understanding can be made of the method and motivations behind specific tool manufacture and discard. In this analysis, reduction is measured by the number of workable platforms remaining at the point of discard. Reduction strategies are heavily influenced by raw material quality. In the Oldowan at Sterkfontein we see that quartz was the preferred raw material due to its easy flaking and production of many razor sharp,

small flakes (mean 35mm), so during this period we find quartz cores well reduced through free hand random flaking techniques into polyhedral shapes (Kuman 2007).

In the Early Acheulean at Sterkfontein we see the increase of quartzites as a preferred choice of raw material. The Dump 21 cores show similar reduction strategies to the Early Acheulean core reduction, i.e. the dominance of the reduction of cores through various stages on multiple platforms resulting in the formation of a polyhedral shape. Figure 4.3 presents the core types for the Dump 21 collection. The mean number of remaining platforms on the Dump 21 cores is one, with five cores (19%) having no remaining platforms (these cores have been exhaustively reduced), nine cores (34%) with a single remaining workable platform, seven cores (28%) with two remaining platforms and five cores (19%) with three or more remaining platforms (Figure 4.5). That 81% of the cores have one or more workable platform remaining and only 19% having been fully reduced is significant regarding the use of these raw materials. Nearly half (47%) of the cores have two or more remaining platforms. These figures suggest that the quartzite cores were utilised expediently and raw materials were close by and easily accessible.

In order to be able to support this conclusion one needs to look at the flake scars on the cores to gauge the raw material quality. The number of step and hinge terminations could have a great influence on the reason the core was abandoned early, leaving remaining workable platforms. As discussed earlier most of the cores are made using fine grained quartzite from river gravels (88.5%). Even when the raw materials have comparable grain size, many flaws can be present affecting the flaking properties of the core. In the Dump 21 cores, 10 artefacts (38%) have no step or hinge terminations, four cores (16%) have only one bad termination, seven cores (26%) have two step or hinge flake scar terminations and five cores (20%) have greater than three bad terminations (Figures 4.6 and 4.7). The median number of step or hinge terminations is 1.5 and the mode zero. In terms of raw material quality it is generally considered that when more than two step or hinge terminations are present on a core then discard prior to core exhaustion is justified by poor raw material properties. So 80% of the Dump 21 cores have two or less step or hinge terminations, meaning that only 20% of the cores can be judged as having enough flaking flaws to be discarded before all platforms have been exhausted. Of all the scars (n=221) on the D21 cores, only 15% (n=34) have step or hinge terminations indicating that the majority of removals were successful and ended in feather terminations.

Another contributing factor to gauging raw material quality and subsequent utilisation is the size and number of the flake scars remaining on the core. A standard measurement on cores, this allows one to compare raw material quality and knapping skill across assemblages (Figure 4.8). It is, however, most useful when one bears in mind the flake scar termination statistics. The flake scars represent the last flakes that were removed from the core before it was discarded. The mean flake scar length on the Dump 21 cores is 52mm (mode 51mm; median 49mm). The success ratio of generating flakes without bad terminations is, from the available data, five flakes from every six exhibiting a smooth feather termination (conversely only one flake in six terminated in a step or hinge fracture). It can be suggested from this success ratio and the flake scar sizes that the raw material was chosen well and skillfully used but discarded before the core was exhausted due to the high availability of raw materials.

Quantity (measured in percent) of remaining cortex on the core surface is used as evidence for the analysis of core reduction. Generally speaking, the more stages of reduction a core goes through the smaller the percentage of cortex will be remaining on its surface. The primary stage of core reduction involves the removal of cortex in order to get to the finer, unweathered core interior. On the Dump 21 cores, 10 pieces (38%) have 0-25% remaining cortex and these cores show a mean flake scar count of 11. Another 10 cores (38%) have 25-50% cortex remaining and these cores have a mean flake scar count of eight. Five pieces (19%) have 50-75% cortex cover, these cores having a mean flake scar count of six scars per core. The remaining one core (5%) has a 75-100% cortex cover and correspondingly has only one flake scar (Figures 4.9 and 4.10). Only the manuport has 100% cortex, which by definition is a piece that is brought into the site but unused. The median quantity of cortex remaining is 25-50%. One can see from the data above that 76% of the cores have less than 50% cortex remaining and almost 40% of cores have less than 25% remaining cortex. This corresponds with the rest of the Dump 21 core and flake data that suggests that most of the cores were reduced through several stages, leaving little or no cortex. The cores that have a greater percentage of remaining cortex have fewer flake scars and appear to have been discarded due to an expedient use of raw material, rather than to raw material flaws, as is suggested from high proportions of feather terminations exhibited in the flake scar termination data.

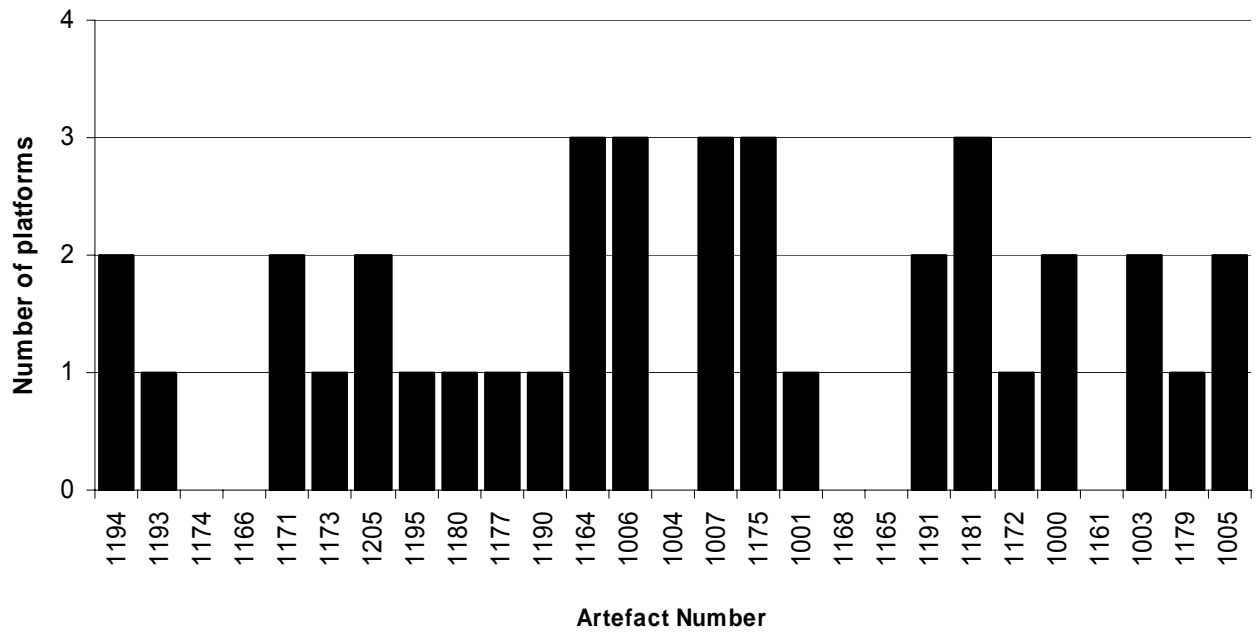

Figure 4.5. Remaining workable platforms on Dump 21 cores.

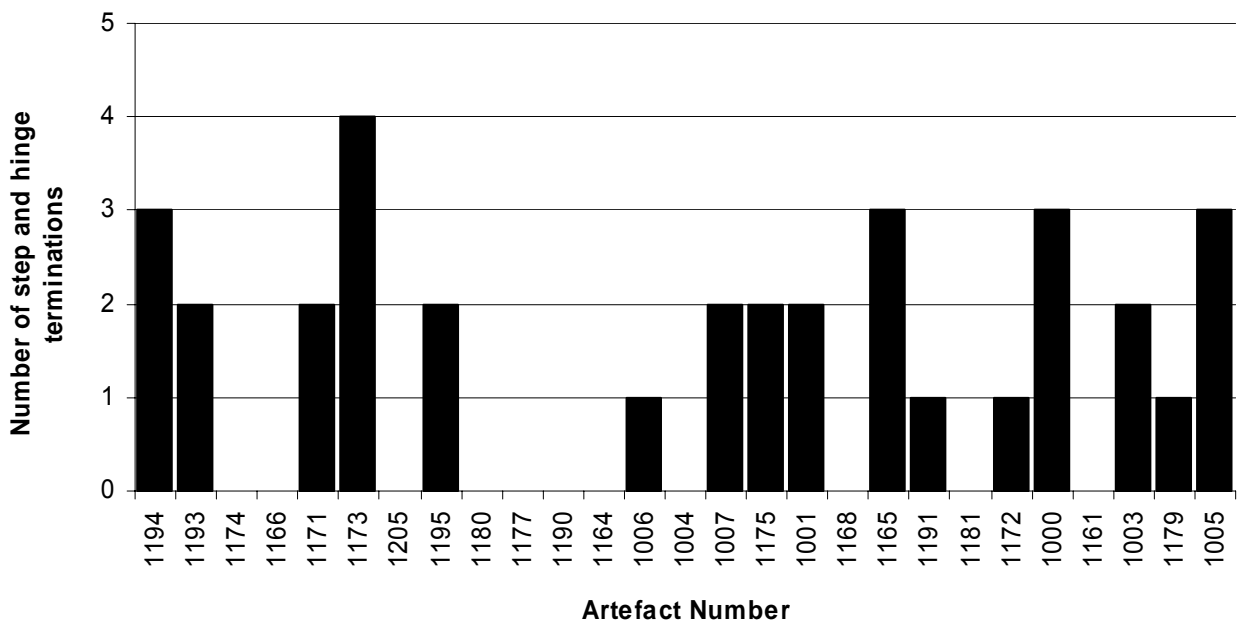

Figure 4.6. Number of step or hinge terminations on Dump 21 cores.

■ No step terminations ■ 1 Step termination
■ 2 step terminations ■ 3 or more step terminations

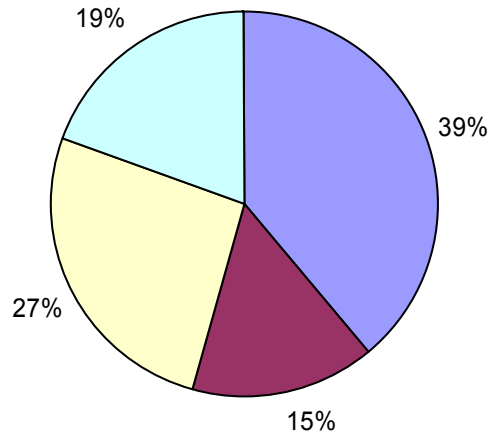

Figure 4.7. Proportion of Dump 21 cores with step or hinge termination flake scars.

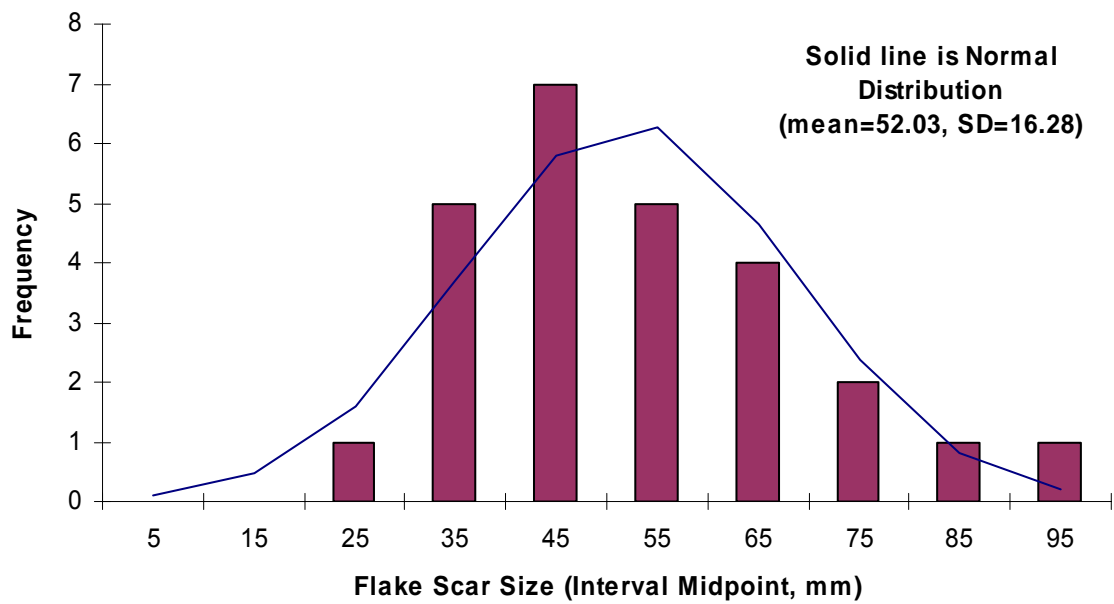

Figure 4.8. Bell curve graph of flake scar size on Dump 21 cores.

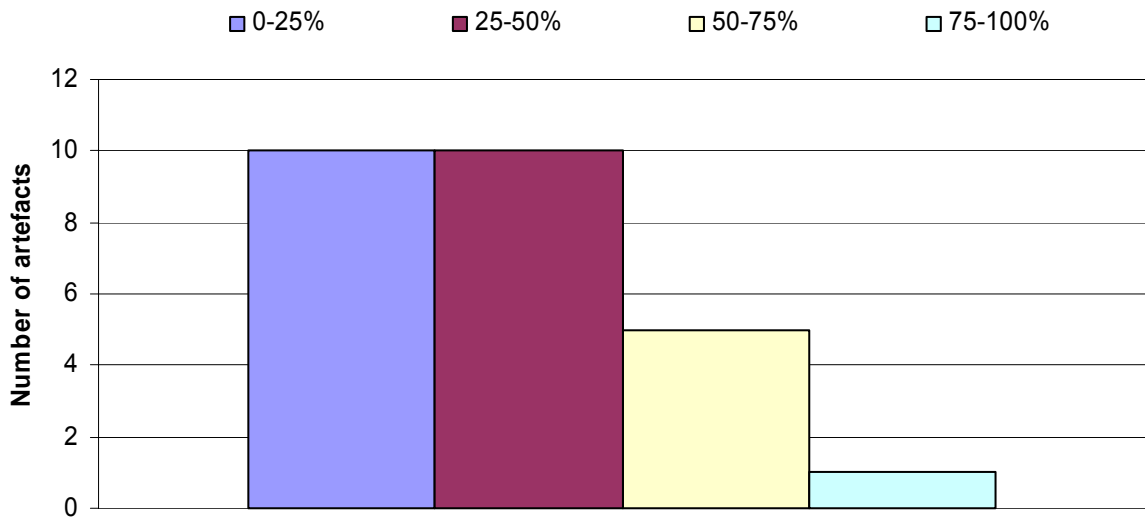

Figure 4.9. Remaining cortex quantities on Dump 21 cores.

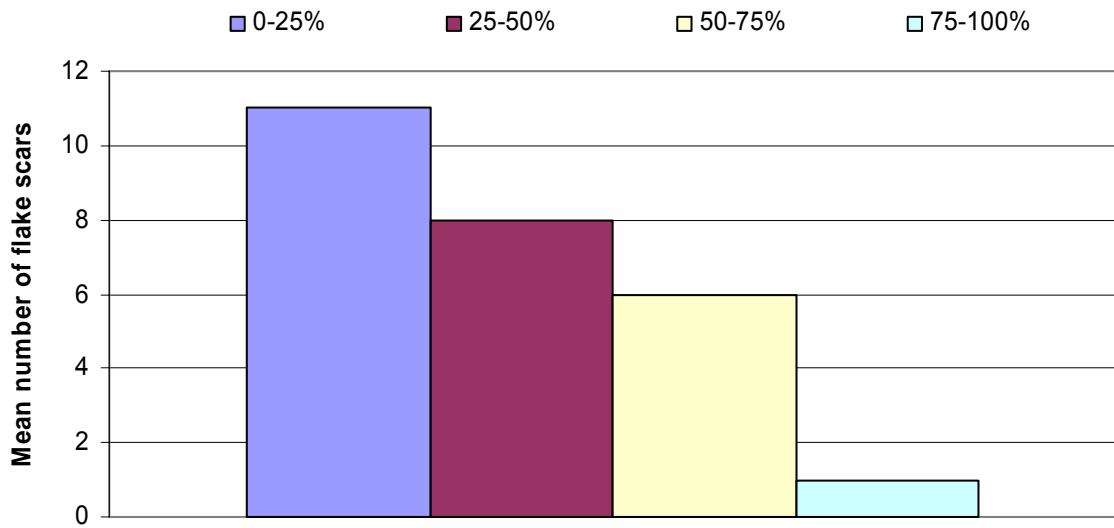

Figure 4.10. Mean flake scar number per remaining cortex value on Dump 21 cores.

Core flaking patterns indicate core reduction strategies. Below, in Tables 4.9, 4.10 and 4.11, the Dump 21 cores have been organised by flaking pattern, and the mode and median values for the key core features are also presented. Three flaking patterns have been recognised: random, radial and bifacial/casual (including unifacial flaking).

The first category contains most of the cores (15 of 26, 59%) and these have been flaked in a random pattern with multiple platforms (more than three) being utilised. The mean number of flake scars remaining on these cores is nine (mode 6 and 11; median 9 (the small sample size produces two mode numbers)), (Figure 4.11). This repeated use of new platforms to manufacture flakes produces a classic polyhedral shaped core, and is thought to suggest a less organised use of raw material and opportunistic flaking habits. The statistics for the randomly flaked cores with multiple platforms is given below (Table 4.9).

	No. Flake Scars	length max scar (mm)	No. Step Term	Remaining platforms	% cortex cover	Condition*
Mode	6,11	44,51	2	1	25-50	sw
Median	9	51	2	1	25-50	sw
Mean	9	52	na	na	na	na

*artefact condition; sw = slightly weathered, f = fresh, w = weathered

Table 4.9. Attributes exhibited on Dump 21 multi-platform randomly flaked cores.

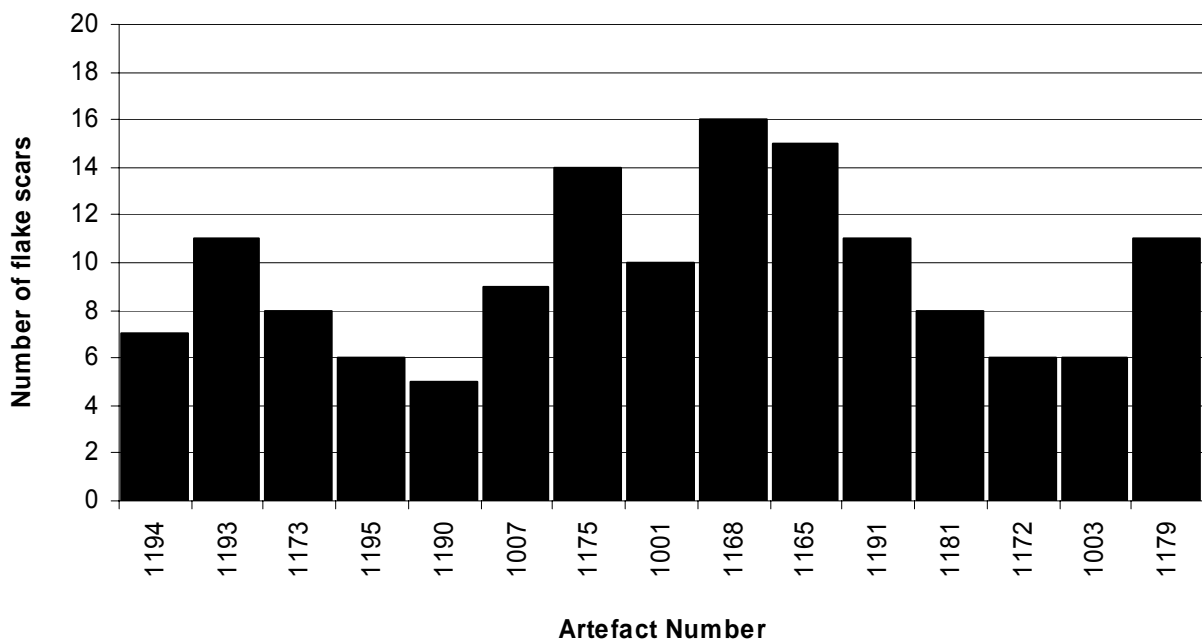

Figure 4.11. Number of flake scars on Dump 21 multi-platform randomly flaked cores.

Of the remaining 11 cores, three cores (11%) have radial flaking patterns and show alternating bifacial flaking along two platforms around the circumference of the core. This method of flaking produces the discoidal core type and may show a more organised approach to flake production and more efficient utilisation of the core volume. In support of this theory we see that the mean number of flakes scars on the radially flaked cores is 14 (median 15) (Figure 4.12). The statistics for the radially flaked cores are given below (Table 4.10).

	No. Flake Scars	length max scar (mm)	No. Step Term	Remaining platforms	% cortex cover	Condition
Mode	na	na	2	2	0-25	sw
Median	15	51	3	2	0-25	sw
Mean	14	59	2	2.3	na	na

Table 4.10. Attributes exhibited on Dump 21 radially flaked cores.

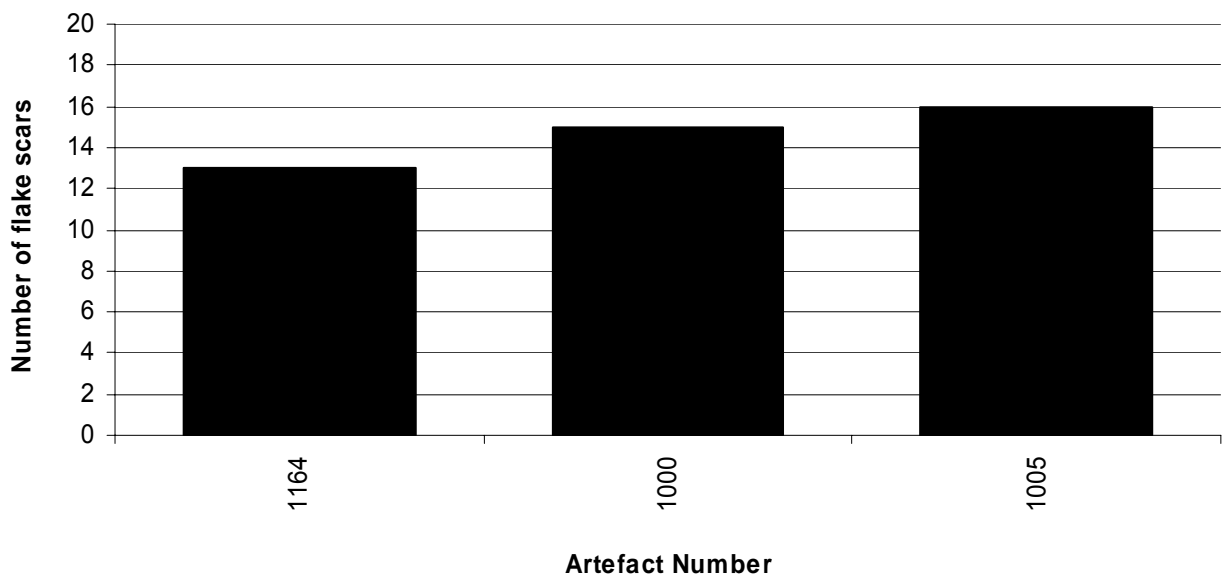

Figure 4.12. Number of flake scars on Dump 21 radially flaked cores.

The remaining seven cores (30%) have a selection of flaking patterns, either casual removals, or bifacial flaking along a portion of the core edge, these cores include, choppers with limited bifacial flaking (less than five scars), single platform cores and casual cores. Platform use is restricted to two platforms, but usually only one is utilized in the creation of a casual core. The mean number of flake scars on these eight cores is 2.8 (mode 3; median 3) (Figure 4.13). This type of reduction and flake production is considered highly opportunistic and the most expedient of the reduction methods as very little of the core is utilised before discard. The statistics for the casually and bifacially flaked cores are given below (Table 4.11).

	No. Flake Scars	length max scar (mm)	No. Step Term	Remaining platforms	% cortex cover	Condition
Mode	3	na	0	1	0-25	sw
Median	3	41	0	1	25-50	sw
Mean	na	44.2	na	na	na	na

Table 4.11. Attributes exhibited on Dump 21 casually flaked cores.

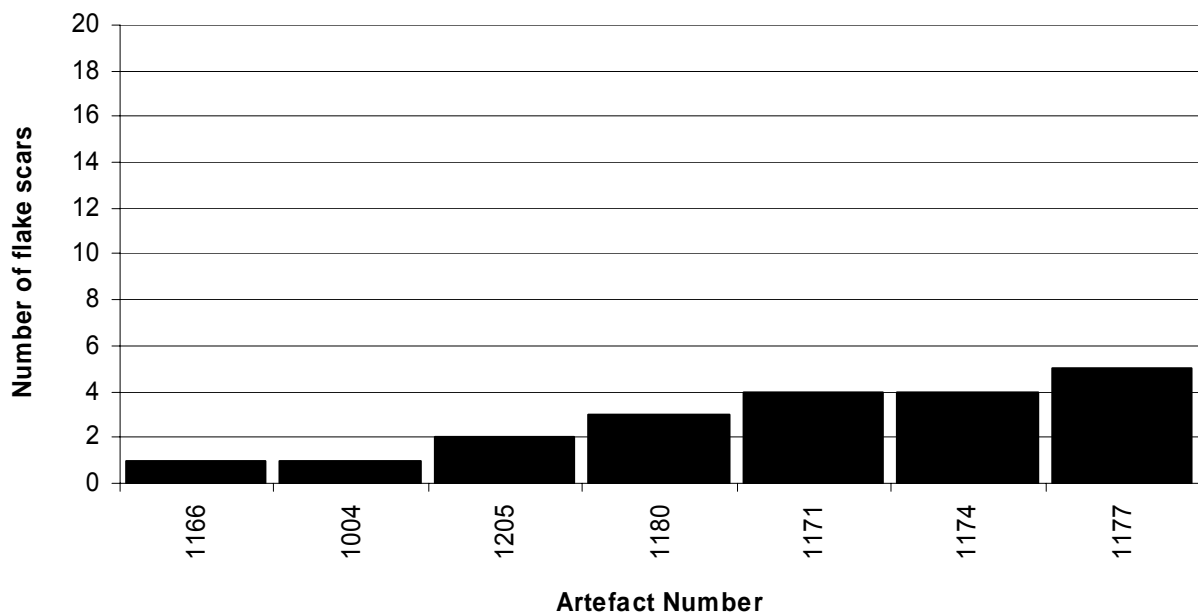

Figure 4.13. Number of flake scars on Dump 21 casually flaked cores.

4.4.2. Flakes

As discussed in the assemblage overview, eight flakes were recovered from the Dump 21 area. Unfortunately such a small sample size prevents the ability to make any inferences regarding technological or behavioral trends. This section will serve to describe the flakes and their technological attributes. Of these eight flakes seven are made from fine grained quartzite sourced from river gravels 300 - 500 meters away and one flake was made from chert. The mean size of the flakes is 62mm with the largest reaching 101mm. It is generally accepted that the ability to remove flakes of greater than 100mm signals the rise of the Early Acheulean. Seven of the eight flakes have full platforms preserved and feather termination distal portions. Only one of the flakes has any cortex remaining on its dorsal face. Six of the flakes have dorsal scars, one of which has 50% cortex cover on its dorsal side, indicating that this particular flake was one of the initial removals during the core reduction when cortex was still being removed from the core surface. The six flakes with flake scars all have flake scar numbers ranging from two to six, the mean being three (mode 2 and 6; median 2.5) (Figure 4.14). The mean dorsal flake scar size on the Dump 21 flakes is 43mm (maximum 55mm) (Figure 4.15). For those six flakes that show dorsal flake scars, this compares closely to the 52mm mean flake scar length on the Dump 21 cores. The data for the Dump 21 flakes is given below (Table 4.12).

	Mean No. Flake Scars	Mean length max scar (mm)	Mode No. Step Term	Mode Remaining platforms	Mode % cortex cover	Mode Condition
Total D21 flakes (n=8)	3	32	0	0	0-25	sw
D21 flakes with flake scars (n=6)	3.8	43	0	0	0-25	sw

Table 4.12. Attributes exhibited on all Dump 21 flakes.

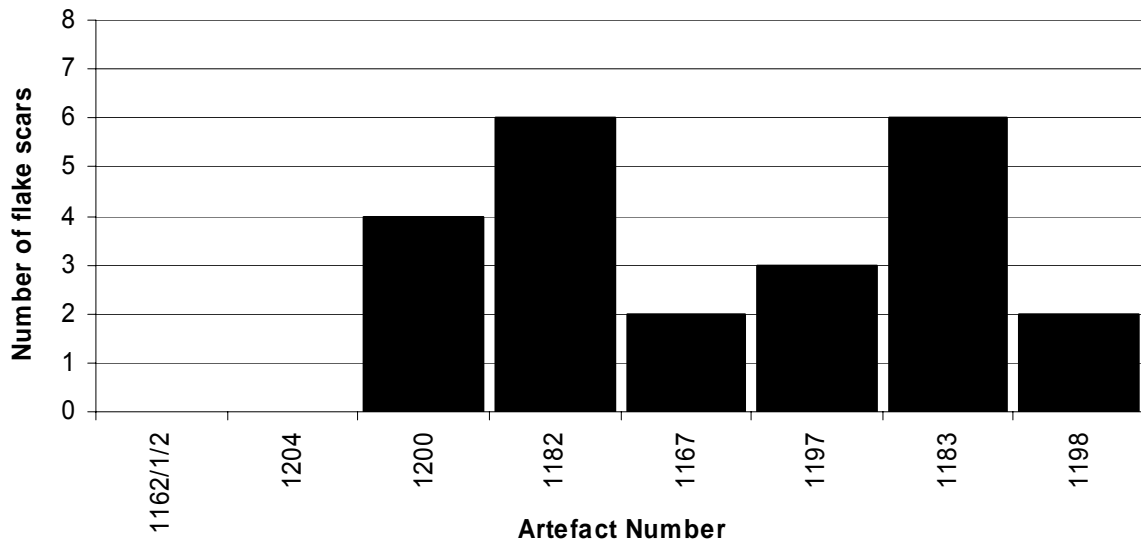

Figure 4.14. Number of dorsal flake scars on Dump 21 flakes.

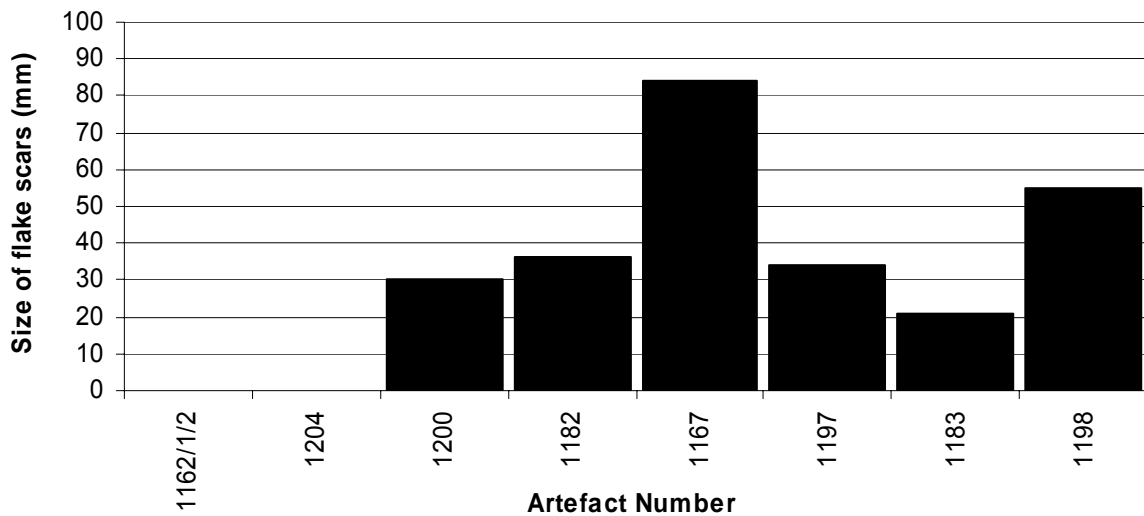

Figure 4.15. Dorsal flake scar size on Dump 21 flakes.

Evidence supporting the dump core data that attests to the success of flaking on the fine grained quartzites is provided on the dorsal scars on the flakes. With a total number of 23 flake scars on all six scarred flakes, there are only two step-terminated scars. This means that only 8% of the dorsal scars on the flakes show evidence of a bad termination. Interestingly those two step terminations occur on a single flake, that flake is, in fact, a

core rejuvenation flake (artefact 1183). Core rejuvenation flakes are usually very specific in shape and function; they are large, thick, mostly triangular shaped flakes removed from a platform or a corner of a core, often where a fault has been found in the raw material that resulted in step terminations. So when an area of this flake's parent core was found to be faulty, a heavier blow was produced by the knapper in order to remove the problem and create a new platform. This flake (artefact 1183) (Length = 42mm, Width = 53mm, Thickness = 22mm) has two step termination dorsal flake scars. This flake is the thickest of the Dump 21 flakes and has been interpreted as a core maintenance flake rather than a tool.

4.5. The Dump 21 Handaxe

The handaxe is the definitive tool of the Acheulean and its production requires good flaking skill and planning. The presence of a large unifacial handaxe within the Dump 21 assemblage warrants special attention and mention. Measuring 129mm (length) by 100mm (width) and 40mm (thickness) when orientated along its long axis, the piece has a volume of 516cm³ and a elongation index of 1.29 (calculating elongation is explained in Chapter 3). The handaxe has been shaped from the blank of a large fine quartzite flake and this flake demonstrates the ability to work large pieces (probably boulders) of quartzite. The flaking, which extends partially around the circumference of the piece, would have produced good size useable flakes (max flake scar = 81mm). In terms of flaking pattern, the piece has been flaked unifacially along the lateral and distal portions and platform of the tool. Judging by the flake scar numbers (15), maximum flake scar length (81mm), and remaining cortex (0-25%), this piece was worked with extra attention and skill. The tip of the handaxe has been broken off and the lateral edges closest to the tip show some very small step terminated flakes characteristic of use-wear. There are unfortunately a number of fresh scars possibly caused within the unfavourable dump context. The data for the Dump 21 handaxe is presented below. Figure 4.29 presents an illustration of the Dump 21 handaxe.

Art Number	L (mm)	W (mm)	T (mm)	Vol (cm ³)	No. Flake Scars	Max scar length (mm)	No. Step Term	% cortex cover
1006	129	100	40	516	15	81	1	0-25

Table 4.13. Attributes exhibited on the Dump 21 handaxe.

4.6. Artefact Condition

As discussed in the assemblage overview, the context of the Dump 21 artefacts makes it difficult to extrapolate any useful data concerning the artefact condition at time of deposition. Typically, in cave sites such as Sterkfontein, if the artefact is found in breccia or within *in situ* decalcified sediment or within the cave system it is still possible to judge the weathering state of the artefact as being close to the condition in which it was buried. This information is useful for the purposes of cave catchment and site formation studies as well as possible artefact curation/discard theories. Dump material, especially material that may have been exposed for as long as a century could have lost any small differences in condition that may have suggested a longer or shorter time exposed prior to burial. Such complications, even bearing in mind the geological time frame needed to weather rocks significantly, makes conclusions on the Dump 21 artefact condition more tenuous. The difference between a heavily weathered piece and a slightly weathered piece, in the context of this dump, may just relate to their positions within the dump and the piece's relative exposure to moisture and plant acids within the dump environment. Nevertheless, in the hopes that someone may be able to provenance the dump material and compare the artefacts to their original neighbours at some point, the Dump 21 artefact condition data will be presented. The manuport has been included as it is part of the assemblage and it would have been exposed to the same weathering conditions as the rest of the artefacts.

In total, including flakes and cores, one piece (2%) is judged as being in a fresh (f) condition, 20 artefacts (58%) are judged to be slightly weathered (sw) and 14 pieces (40%) are judged to be weathered (w) (Figure 4.16). In terms of the condition of cores versus the condition of flakes, five of the eight flakes (63%) were judged to be weathered, two flakes (25%) were slightly weathered and one flake (12%) was fresh. The Dump 21 cores

showed a slightly different trend in that 18 of the cores (66%) were slightly weathered, and the remaining nine cores (34%) were in a weathered condition. The generally higher level of weathering on the flakes may be due to their increased susceptibility to movement and subsequent abrasion or due to their shape and relatively high surface area.

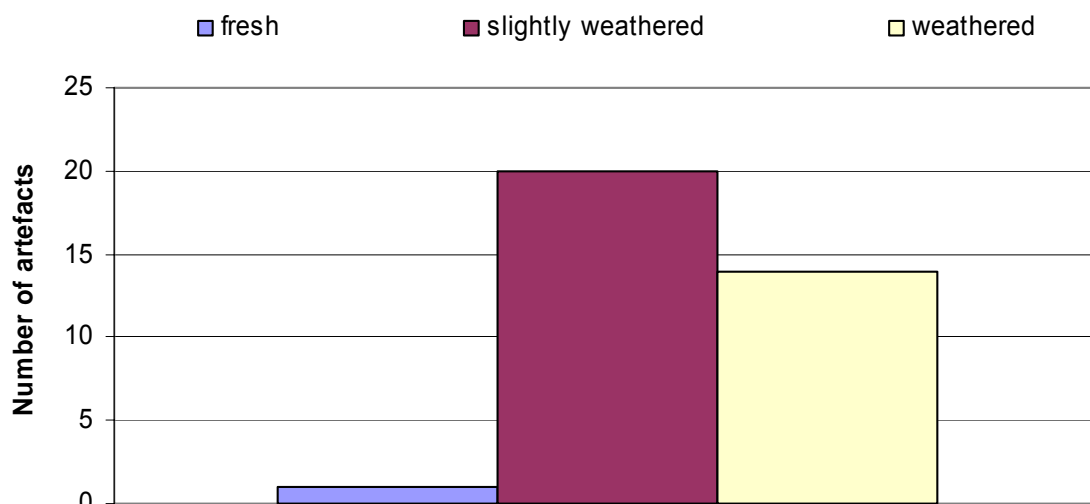

Figure 4.16. Weathering conditions of all Dump 21 artefacts.

4.7. Dump 21 Comparisons with Sterkfontein Early Acheulean

The Sterkfontein Early Acheulean (Sterkfontein EA) assemblage from Member 5 West has already been outlined in the literature review. Unfortunately due to the very small size of the Dump 21 sample, conclusions drawn from statistical or non-statistical data comparisons have a very high degree of uncertainty. As discussed before, comparisons based upon weathering conditions are tenuous when samples have been exposed for different lengths of time. Comparisons between these two assemblages are reduced to observations regarding artefact features and general composition trends in order to assess technological similarities between the two collections. The number of step or hinge termination scars was never recorded on the Early Acheulean assemblage so no point of comparison can be made with this variable. Below the core data for the Sterkfontein Early Acheulean from Member 5 West is presented with the corresponding data from the Dump 21 assemblage in parentheses (Tables 4.14, 4.15, 4.16, 4.17).

	No. Flake Scars	Length max scar (mm)	Remaining platforms	% cortex cover
Mode	4 (6,11)	50 (51)	2 (1)	0-25 (0-25,25-50)
Median	6 (8)	53 (49)	2 (1)	25-50 (25-50)
Mean	5 (8)	52 (52)	2 (1)	na (na)

Table 4.14. Sterkfontein Early Acheulean core data (adapted from Field's (1999) data on the Sterkfontein Early Acheulean quartzite cores) compared with Dump 21 core data (in parentheses).

	No. Flake Scars	Length max scar (mm)	Remaining platforms
Mode	2 (4)	na (na)	2 (na)
Median	2 (3)	45 (41)	1 (1)
Mean	3 (4)	50 (49)	2 (1)

Table 4.15. Sterkfontein Early Acheulean casually flaked core data (adapted from Field's (1999) data on the Sterkfontein Early Acheulean quartzite cores) compared with Dump 21 core data (in parentheses).

	No. Flake Scars	Length max scar (mm)	Remaining platforms
Mode	7 (6,11)	47 (44,51)	3 (1)
Median	8 (9)	53 (51)	2 (1)
Mean	9 (9)	58.5 (52)	3 (1)

Table 4.16. Sterkfontein Early Acheulean polyhedral core data (taken from Field's (1999) data on the Sterkfontein Early Acheulean quartzite cores) compared with Dump 21 core data (in parentheses).

	No. Flake Scars	Length max scar (mm)	Remaining platforms
Mode	17,19 (na)	na (na)	2 (3)
Median	17 (15)	49 (51)	2 (3)
Mean	16 (14)	60 (59)	2 (2)

Table 4.17. Sterkfontein Early Acheulean discoidal core data (taken from Field's (1999) data on the Sterkfontein Early Acheulean quartzite cores) compared with Dump 21 core data (in parentheses). Numbers of step terminations have not been used due to restrictive data samples.

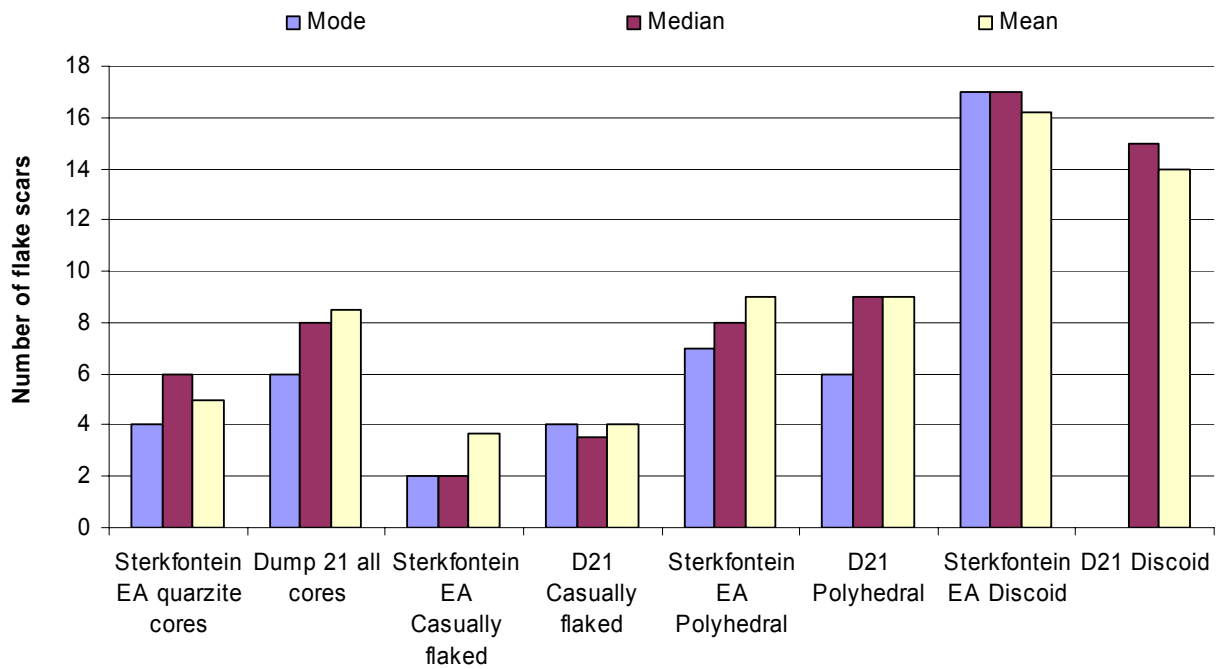

Figure 4.17. Flake scar numbers of Sterkfontein Early Acheulean quartzite cores vs. Dump 21 cores.

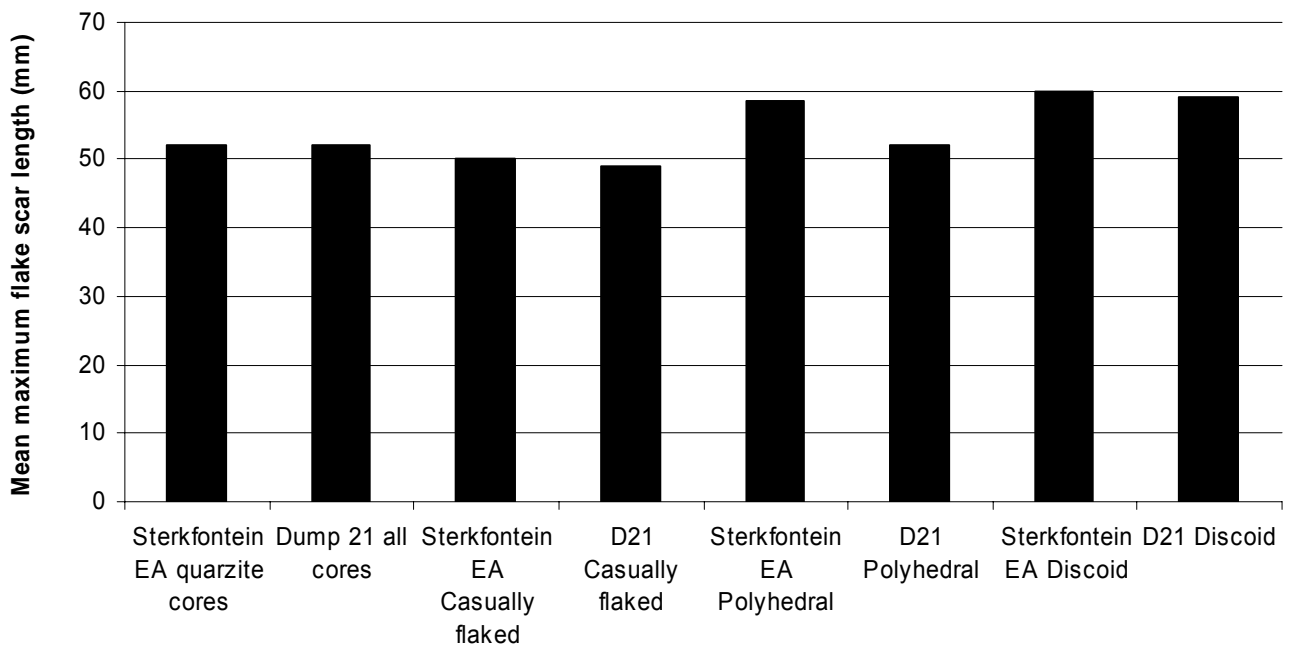

Figure 4.18. Mean maximum flake scar length of Sterkfontein Early Acheulean quartzite cores vs. Dump 21 cores.

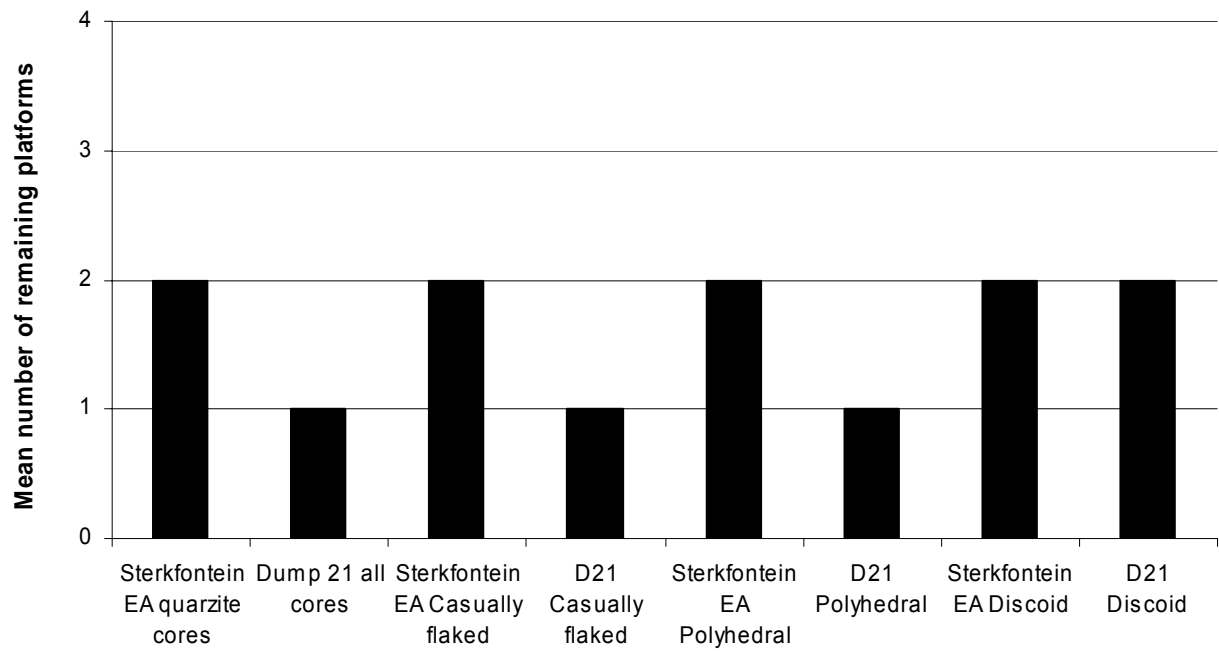

Figure 4.19. Mean remaining platforms for Sterkfontein Early Acheulean quartzite cores vs. Dump 21 cores.

■ Polyhedral
 ■ Casually flaked
 ■ Discoidal
 ■ Bipolar
 ■ Unclear

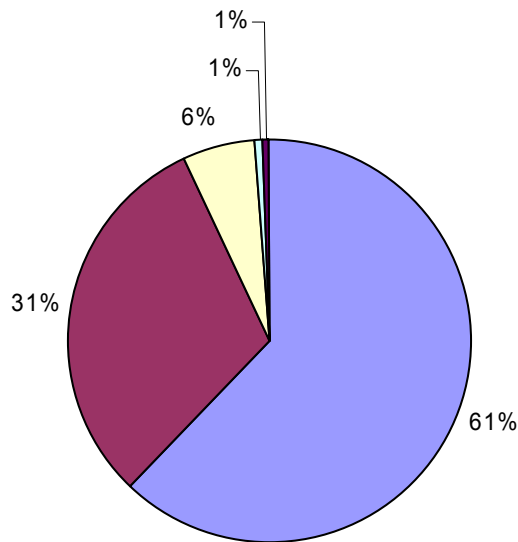

Figure 4.20. Sterkfontein Early Acheulean quartzite core types.

It should be noted that ‘Sterkfontein EA casually flaked’ cores includes all casual cores as defined by Clarke (1970) and irregularly bifacially flaked cores with fewer than five flake scars, in the same way ‘D21 casually flaked’ includes all casual as defined by Clark (1970) and irregularly bifacially flaked cores with fewer than five flake scars. It should also be noted that only the Sterkfontein EA cores worked in quartzite have been used for comparison, so as to rule out any raw material flaking differences. As one can see from the above Figures (4.17, 4.18, 4.19, 4.20) three features found on both sets of cores have been compared. Flake scar number, mean flake scar size, and number of remaining platforms, these data provide a better perspective of the technological features on the cores that are not sample size dependant and provide a better general spectrum of comparison. Comparison of these features will allow one to observe technological similarities regarding the flaking trends and utilisation of these quartzite cores. From the above data there are distinct similarities between the general trends in core utilisation and the specific core type trends.

Firstly, both assemblages show similar trends in the reduction of cores into specific core types. Since they both show similar proportions of core types. Polyhedral cores dominate at 61% of the Sterkfontein EA quartzite cores and 57% of the Dump 21 cores; casually flaked cores in the Sterkfontein EA and Dump 21 assemblages both make up 31% of their collections and Discoidal cores (Discoids) make up 6% and 12% respectively. If one assumes that the dump was created without any selective influence then one can compare general trends in composition of both assemblages regardless of sample size. Accurate technological inferences based upon composition alone, given the Dump 21 sample size would, however, be misleading. What is evident is that there are similar proportions of core types within the Dump 21 collection and the Sterkfontein EA quartzite core collection.

Although the Dump 21 cores, on general, have a greater number of mean flake scars (8 compared to 5), one can see from the specific core types that the mean number of flake scars are very similar. The polyhedral cores show an identical mean number of flake scars ($n=9$). The casually flaked cores have a mean number of flake scars of three (Sterkfontein EA) and four (Dump 21), and the discoidal cores have mean flake scar number of 16 (Sterkfontein EA) and 14 (Dump 21).³

³ It would be conventional to use formal statistics to assess whether the measurements made in each of the assemblages are different. The chi-squared test could be used to

It is also evident from the data that there are close similarities between the two assemblages regarding the ability to regularly remove similarly sized flakes. The mean largest flake scar for all the cores through the Sterkfontein EA quartzite and Dump 21 assemblages is 52mm. The difference between the Sterkfontein EA and Dump 21 mean largest flake scar length is only 1mm for both casual and discoidal cores, and 6mm for the polyhedral cores.

When comparing the mean number of remaining platforms one can see that the results are distinctly similar. The mean number on the total Sterkfontein EA quartzite cores is 2 compared with 1 for the Dump 21 cores. The specific core types show a comparable trend; only the polyhedral cores show a difference of one mean remaining platform. This evidence, coupled with analogous remaining cortex percentages for both sets of cores (median and mode are identical), one can infer that the level of core reduction and discard point of the Sterkfontein EA quartzite cores and the Dump 21 cores across the equivalent core types are comparable.

Due to the small numbers of quartzite flakes found in the Sterkfontein EA (n=16; 8 complete; 8 incomplete; 3.5% of quartzite artefacts) and Dump 21 (n=8; 5 complete; 1 incomplete; 2 core maintenance; 23% of Dump 21 artefacts), technological comparisons based on flake features are impractical and potentially highly inaccurate and have not been included.

A point of interest when comparing these two assemblages is the presence of the heavy duty tools. In the Sterkfontein EA collection only seven chopper cores are represented, all of which are made of quartzite. These core tools represent 1.5% of the quartzite artefacts and are clearly not the primary knapping objective of the Sterkfontein EA assemblage. Only one core tool is represented within the Dump 21 collection (3%), the unifacial handaxe. The Sterkfontein EA handaxe (SEA 1) is highly comparable to the

examine the hypothesis that the distribution of core types (polyhedral : casual : discoid : other) is different in the D21 assemblage (15 : 8 : 3 : 0) from the Sterkfontein EA assemblage (106 : 53 : 10 : 2). Normalising each distribution to 100% and applying the chi-squared test gives a value of 3.187, with 3 degrees of freedom. In this case $p > 0.25$, and the hypothesis that the distributions are different can be rejected (the chi-squared value would need to be > 7.81 to be able to state with 95% confidence ($p < 0.05$) that the distributions are different). However, applying formal statistics when there are only a few categories, distributions are biased, and observation numbers are small can be misleading. Assessment of the differences between data sets have therefore been restricted to simple comparisons of normalised values.

Dump 21 handaxe in size and flake scar count, SEA 1 is 109mm x 83mm x 59mm (533cm³) and has 15 flake scars, artefact 1006 (Dump 21) is 129mm x 100mm x 40mm (516cm³) and has 15 flake scars. The blanks used for flaking do differ. SEA 1 is shaped from a river cobble and the D21 1006 is made from a large flake.

4.8. Dump 21 Conclusion and Discussion

From the all the Dump 21 data above one can make a number of inferences about the assemblage without the need of context specific inferences. As explained in the introduction, the Dump 21 assemblage is of limited use to the study of the other Sterkfontein stone tool collections. With no provenance or context, the value of these stone tools and cores is limited to examples of technological capabilities of hominids at Sterkfontein during a time period that can be suggested from typological comparison with the other Sterkfontein assemblages. The closest part of the Sterkfontein site to the Dump 21 location is the Member 5 West Extension site. This area of the main excavation has yielded artefacts with faunal associations and adhering breccia that suggests an Early Acheulean origin. The presence of large flakes, a handaxe and the dominance of quartzite certainly precludes the Dump 21 assemblage from the Oldowan or the Middle Stone Age. Logically, if the material is not mixed, the assemblage has to come from some point in the Acheulean.

Firstly though, it is necessary to amalgamate the Dump 21 data and clarify the technological inferences possible from the features within this assemblage. The interpretation of the data is presented from the chronological perspective of the artefacts i.e. from raw material choice through flaking to discard.

The Dump 21 cores are all made upon the fine quartzite river cobbles from the nearby Blaaubank River gravels which have remained at a distance of 300 to 500 meters for at least the last 2 million years. These finer quartzites were recognised within the river gravels by their smoother cortex. Once selected, these cobbles may have been partially flaked at the river bank. The location of the flaking of the Dump 21 artefacts is impossible to know due to its lack of context. The fine quartzite cobbles that were selected for flaking were worked with skill and understanding of stone fracture dynamics as is suggested by the low proportion of bad flake terminations and larger sizes of flake scars. When a

problem with the raw material was experienced the knappers had the ability to repair and rejuvenate the core. It is indicated, however, from the number of remaining platforms, that cores were not fully utilised and frequently discarded prior to core exhaustion. This trend may have been due to the easy availability of the raw materials and the opportunistic need for flakes. The reduction strategies represented in the Dump 21 assemblage were predominantly expedient, opportunistic, short term and unplanned techniques that produced flakes of a highly variable size and resulted in the production of polyhedral, casual and bifacial cores. The presence of three radially flaked cores indicates that the ability to carry out more efficient, planned production of more regular flakes was present but not required for most knapping events. Certainly the chief intention of the knappers of the Dump 21 artefacts was to produce flakes quickly, the size of these flakes seems to have been a secondary concern, but the skill of the knappers and the raw material quality means that few flake removals failed. The sporadic need for more efficient flake production (radial reduction) producing discoids may relate to environmental conditions influencing the access to raw materials.

Having completed the successful production of as many flakes as was needed for the job in hand the core was discarded. One can see from the number of flake scars on the flakes and cores that reduction was fairly intensive, the core being reduced through several stages, until very little cortex was remaining. It could be suggested from the number of remaining platforms through the different reduction strategies that when radial flaking was instigated and extra care was taken to produce flakes more efficiently, the core was discarded at an earlier stage due to the flake quota being reached.

From the Dump 21 flake data one can see a comparable pattern to that seen in the cores. The majority of the Dump 21 flakes were removed well into the reduction of the core, indicated by the lack of cortex on the dorsal side and high dorsal flake scar count. The majority of the D21 flakes are complete and dorsal flake scars on both flakes and cores that indicate that few bad terminations took place. When a flake removal did fail due to raw material fault the knapper exhibited the ability and understanding to remove the area in question and rejuvenate the core platform. This, in turn, suggests that when step or hinge terminations are encountered on the artefacts it was not the poor skill of the knapper that produced the bad termination but a fault within the raw material. None of the flakes are retouched implying that flakes were not curated and re-used but were to be used expediently. These flakes were produced using two different reduction strategies, most of

the flakes demonstrating use of the unplanned free-hand percussion techniques that produce the polyhedral and casual core shapes. When more efficient flake production was necessary, maybe due to a period of restricted access to raw materials, more efficient, planned reduction methods were utilised, producing large numbers of flakes and the discoids that are represented in the assemblage. None of the artefacts show any evidence of other percussion techniques.

The presence of the large unifacial handaxe helps to clarify the technological abilities and practices of the hominids that created the Dump 21 artefacts. The ability to remove large flakes (>100mm) from large raw materials and work them into heavy duty tools is demonstrated by the presence of this core tool. The need to produce such large tools was probably of secondary importance to the quick, opportunistic and expedient production of flakes as cutting tools.

The cores and used flakes were discarded around the cave openings of the Sterkfontein system. The artefacts were then subject to weathering and natural transport and were deposited into the cave system. Once in the cave system the artefacts were brecciated with the other sediment and perhaps decalcified before being uncovered and removed from their context (and any associated artefacts and fauna) by the lime workers and dumped in the location that is now Dump 21.

One can see from the comparative data in Section 4.7 that there are certain similarities between the Sterkfontein Early Acheulean quartzite collection and the Dump 21 assemblage. Both collections show comparable proportions of core types, flaking trends and reduction techniques. Field (1999) observed several similar conclusions regarding the Sterkfontein EA to the conclusions illustrated above for the Dump 21 assemblage. Namely that: (1) the high percentage of river cobble cortex on artefacts confirms that the hominids selected cobbles and brought them to the site; (2) full reduction of cores was not always employed, flaking was frequently stopped before the cores were exhausted; (3) “the flaking strategy tends most often to be opportunistic, which is probably because the raw materials are nearby”; (4) the largest proportion of cores are the polyhedral and casual/bifacial cores; (5) radial core reduction techniques are understood but not often employed; (6) 64% cores of the quartzite cores have more than one remaining platform (81% on Dump 21 cores), suggesting the quartzites cores were not often fully reduced. Field also observed that there are two core reduction strategies evident in the Sterkfontein EA. The first is the more casual, opportunistic reduction technique

which produces the casual, bifacial and some polyhedral cores with relatively low flake scar counts and high numbers of remaining platforms. The second is the more intensive reduction strategy that produces the other polyhedral and discoidal cores with greater numbers of flake scars, and fewer numbers of remaining platforms (Field 1999).

The conclusions drawn by Field and those drawn in this analysis are very similar indeed. It could be, however, be argued that all the polyhedral cores should be classified within the more 'casual' core reduction strategy Field describes, as they display a random flaking pattern and demonstrate a flaking intention that facilitates a quick and simple way to produce many flakes of varying size. One could also argue, on the basis of knapper intention, that the radially flaked cores (discoids) represent the only cores to be classified within the more intensive core reduction strategy described by Field, because they demonstrate a planned reduction strategy for the removal of flakes in an orderly fashion in order to produce a high number of similarly sized flakes.

It seems probable, from the data from the Sterkfontein EA quartzite assemblage and the Dump 21 assemblage, that these two assemblages were originally one. That is to say that the Dump 21 artefacts bear strong enough similarities to the Sterkfontein EA quartzite artefacts to have originated from the same context. If the Dump 21 material was simply lifted from the Member 5 West deposit and dumped without selection or mixing it is logical that similar artefact features, types and proportions would remain. It is also likely that the smaller parts of the assemblage were missing before extraction from the original context and have been further winnowed away after an extensive exposure to weathering on the surface. The Sterkfontein EA assemblage from Member 5 West is the closest of the Sterkfontein excavated assemblages and it is evident that the lime workers removed a portion of the Sterkfontein Early Acheulean assemblage and dumped it six meters west and four meters south of the current M5 West excavation creating the Dump 21 assemblage. Table 4.18 provides the data for the combined Sterkfontein Early Acheulean and Dump 21 assemblages.

Artefact Types		Chert	Quartzite	Quartz	Total	%
Small flaking debris						
<20mm	-		1	18	19	2.5
Chunks <20mm		14	54	44	112	15.0
Incomplete flakes						
≥20mm		2	9	23	34	4.6
Complete flakes ≥20mm		1	12	13	26	3.5
Retouch Pieces	-		2	1	3	0.4
Core Fragments	-		7	4	11	1.5
Flaked Flakes	-		4	1	5	0.7
Core Maintenance Flakes			2	0	2	0.3
Cores		9	196	78	283	37.9
Irregularly Fractured						
Cobble	-		21	7	28	3.8
Core tools	-		8	-	8	1.1
Utilised Cobbles	-		2	-	2	0.3
Manuports		21	171	17	209	28.0
Uncertain types		2	2	-	4	0.5
Total		49	491	206	746	100.00%
%		6.6	65.8	27.6	100%	

Table 4.18. Assemblage profile of the combined Dump 21 collection and the Sterkfontein Early Acheulean.

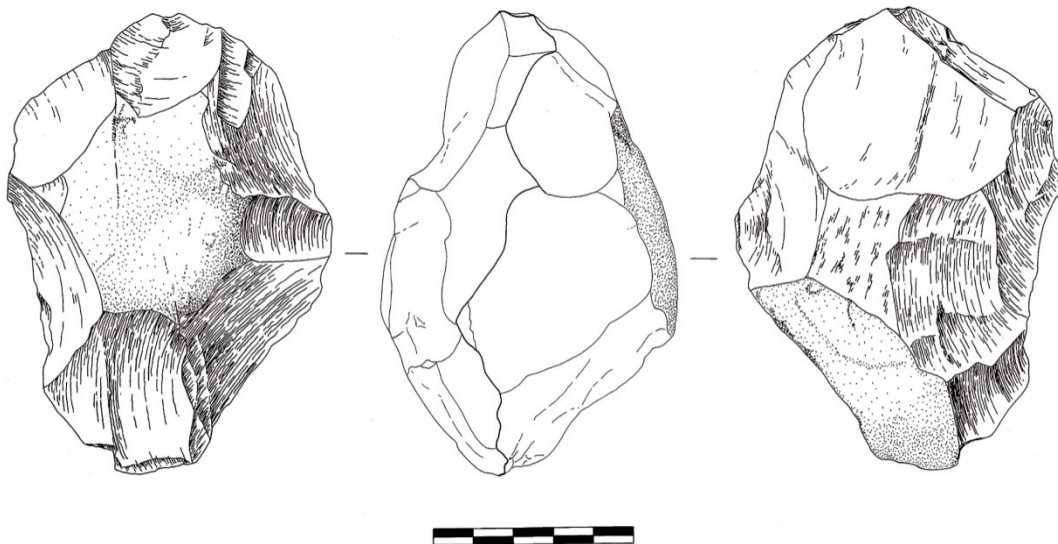

Figure 4.21. D21 1000.

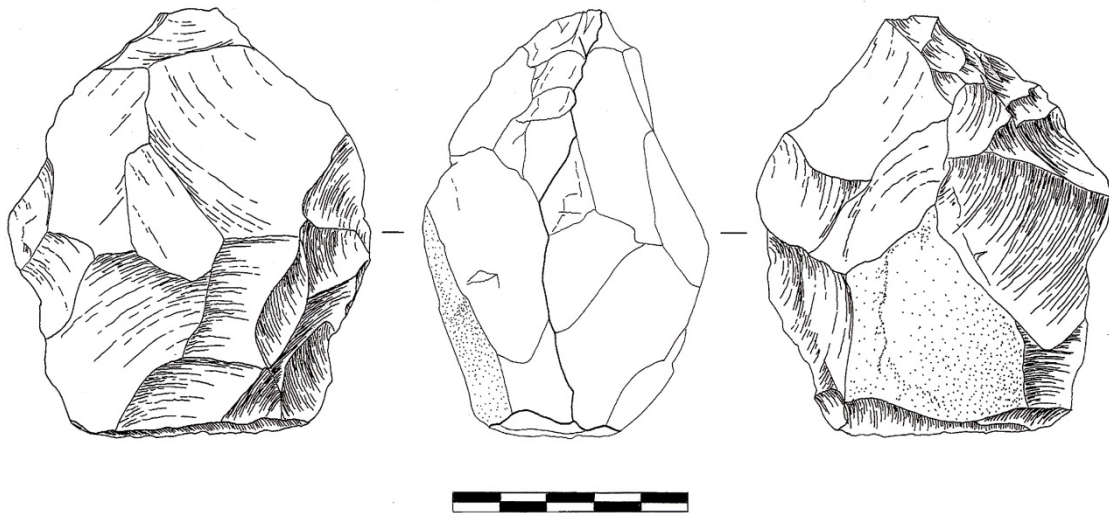

Figure 4.22. D21 1005.

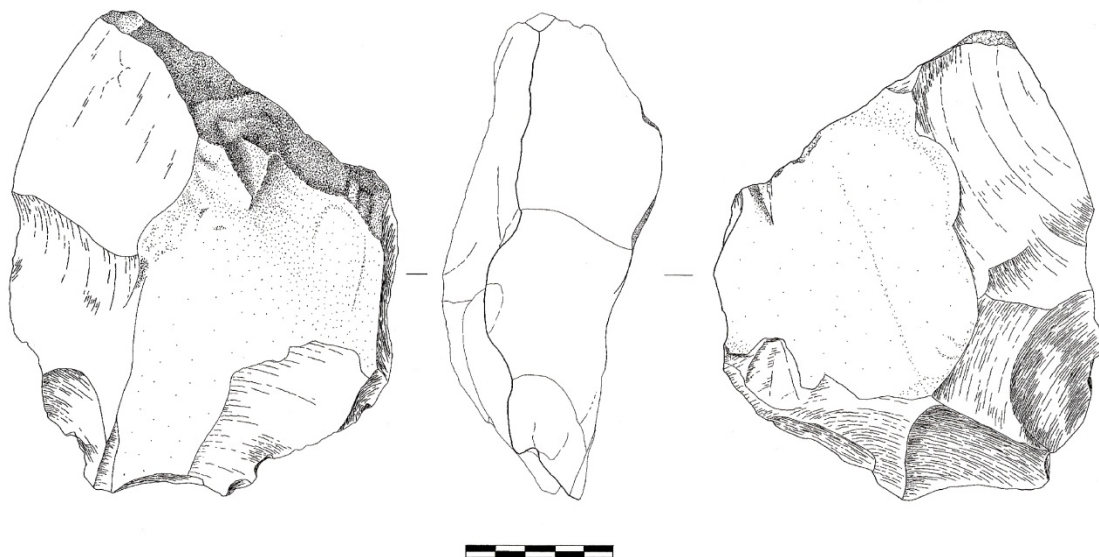

Figure 4.23. D21 1164.

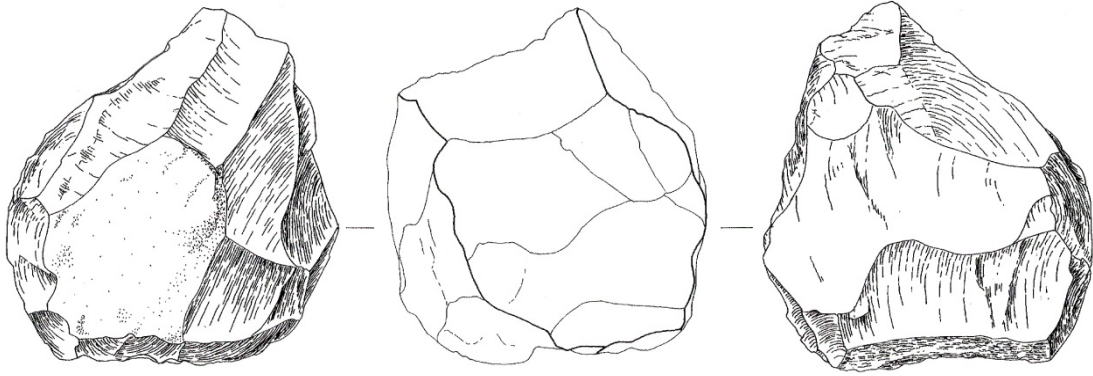

Figure 4.24. D21 1165.

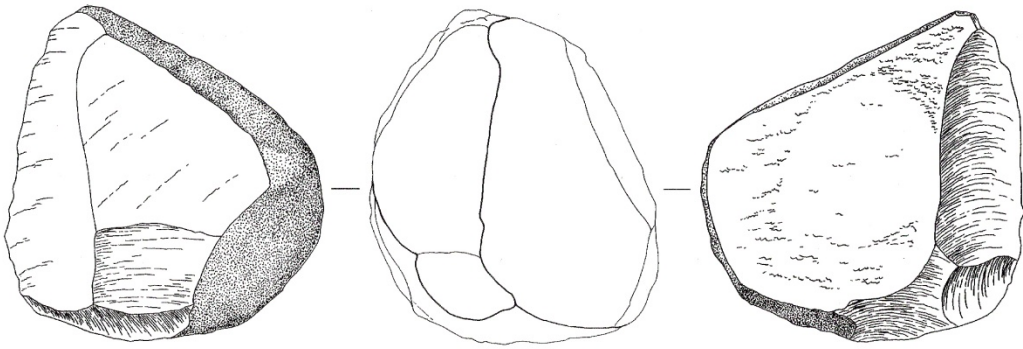

Figure 4.25. D21 1174.



Figure 4.26. D21 1175.

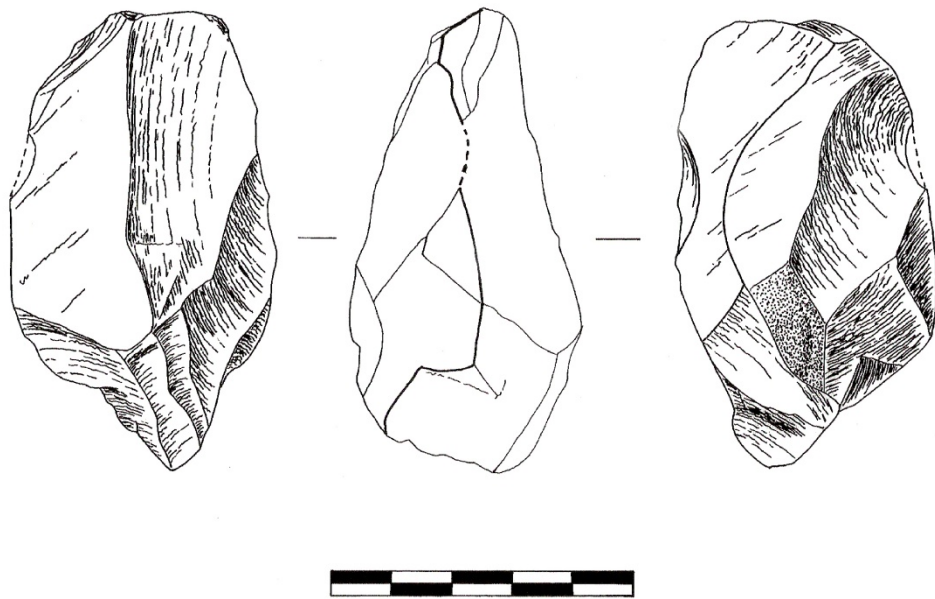

Figure 4.27. D21 1179.

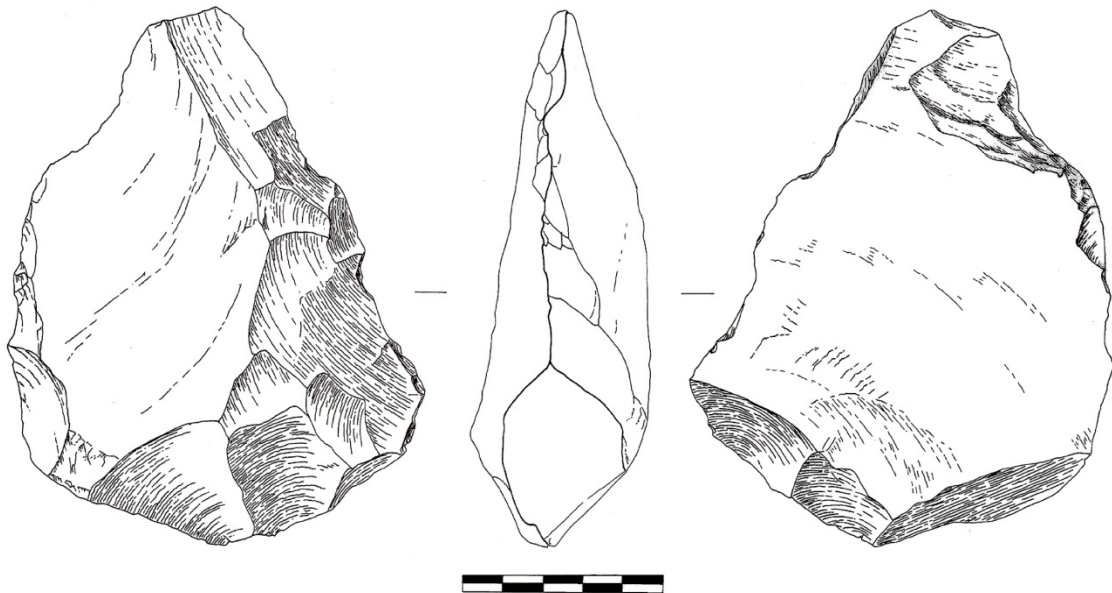

Figure 4.28. D21 1006.

Chapter 5. Name Chamber Stratigraphy and Archaeology

5.1 Name Chamber Stratigraphy and Site Formation

Introduction

The Name Chamber lies at the hub of the Sterkfontein karst system. The deposits within the Name Chamber have complex interactions with the deposits of the other central chambers. The Silberberg Grotto, Milner Hall, Jacovec Cavern and the past and current tourist path all relate, influence and are influenced by the Name Chamber deposits. Recent work with Prof. Clarke and Dr. Bruxelles has significantly clarified the formation processes and stratigraphy of the Name Chamber deposits that were described in the literature review. This recent and ongoing work has revealed a complicated set of depositional sequences that have shaped deposits within the Name Chamber and possibly the other closely related chambers. Micro-stratigraphy identified within the more recent younger 'soft' deposit indicates possible periods of surface erosion fluctuations. Four types of evidence are being used to understand the order of deposition and source of sediment: stratigraphic analysis of the Name Chamber deposits, micro-fauna analysis, archaeological analysis and faunal analysis including taphonomic investigation. The focus of this research is the stratigraphic and archaeological analysis of the Name Chamber. The taphonomic analysis may allow comparisons between the Name Chamber faunal accumulation processes and those prevalent in the other Sterkfontein members. The micro-faunal analysis may allow species proportion and perhaps environmental conditions to be compared and contrasted between the Name Chamber and the other Sterkfontein deposits. Micro-faunal analysis may also help unveil any mixing of deposits. The micro-faunal, macro-faunal and taphonomic analyses are currently being addressed by other specialists. Preliminary results of these studies are encouraging, and although we await the multi-disciplinary results, the stratigraphic and archaeological studies are key components to understanding the history of the Name Chamber.

5.1.1. Stratigraphic description of the Name Chamber deposits

The filling of the Name Chamber can be described in three phases.

- I. The ancient brecciated infill
- II. The old brecciated deposit
- III. The younger 'soft' deposit

I. The ancient brecciated infill

This deposit accumulated before the karst system was open to the surface, when a dark, stony breccia accumulated through internal collapse within the cave. This breccia consists only of blocks of dolomite and chert of varying size and orientation and shows no signs of depositional sorting, indicative of a deposit whose formation is unaided by water. As the surface above the Sterkfontein caves eroded down, the chambers within the system gradually came closer to the land surface. When only 10-15 meters separated the chamber from the surface, decompression within the cave system occurred and destabilised the cave walls and ceilings (Bruxelles, personal communication). The subsequent collapse of internal ceiling blocks and walls opened and closed different chambers and allowed the filtering down of fine, manganese rich (dark) sediment to enter the chamber. Such dark sediment is known to form from the element-leaching deeper soils in contact with the dolomite. This process of internal collapse and deposition occurs in all dolomitic limestone karst systems. The deposition that filled the Name Chamber and all the original chambers of the Sterkfontein system before the cave was completely open to the surface is now known as the Member 1 breccia. The calcification of this huge deposit has allowed its remnants to adhere to the walls and ceilings of all the chambers. In the Name Chamber the upper walls and ceiling are covered with this Member 1 breccia with large to huge blocks of fallen dolomite (from the continued decompression of the chamber) cemented to the ceiling at angles opposite to the natural bedding planes of the Sterkfontein caves. The Member 1 deposit filled the Name Chamber and was capped by a thick flowstone that still cements parts of the Member 1 breccia to the ceiling and walls. Figure 5.1 shows the ancient brecciated infill (Member 1) on the southern wall of the Name Chamber.

Once the karst system had opened to the surface, the Member 1 breccia was eroded down to lower systems opened by the drop in the water table. It should be noted that at different points in time different openings to the surface allowed the erosion of the Member 1 breccia in different chambers. The erosion of the Member 1 breccia was not facilitated by one opening, nor did it occur contemporaneously throughout the chambers. In the Name Chamber, once the deep feeding shaft to the north had opened, erosion of the Member 1 breccia started. The most resistant breccia, the examples adhering to the walls and ceiling, remain in place. All the subsequent deposits within the Name Chamber, Jacovec Cavern, Silberberg Grotto and Lincoln Cave show some degree of sediment sorting, indicating the presence of water involved in the deposition of these sediments, and possible only after the opening of the system to the surface. In the Name Chamber this sorting can be seen in the ensuing old brecciated deposit and the younger 'soft' deposit.



Figure 5.1. Remnant of the ancient brecciated infill (Member 1) adhering to the southern wall of the Name Chamber. Note the dark nature of the sediment and the large blocks of randomly orientated dolomite within the deposit.

II. The old brecciated deposit

The erosion of the Member 1 breccia allowed the deposition of the second Name Chamber infill. It is still unclear as to how this deposit relates to the other central chamber deposits (Silberberg Grotto and Jacovec), but Dr. Bruxelles has suggested it may be contemporaneous with Member 2. Sediment of the second deposit is preserved on the lower walls and ceiling of the Name Chamber. In particular it is found on the far eastern wall of the chamber where a depositional profile has been preserved by a capping flowstone (Figure 5.2). This sequence demonstrates the sorting preserved within the breccia caused by the action of the water during the deposition and calcification of the material. The old brecciated deposit sediment is redder in colour than the previous Member 1 deposit and contains large quantities of micro-fauna and macro-fauna. The redder matrix colour indicates the sediment originated from the land surface and is richer in iron than the deeper soils which absorb the manganese from the dolomite and consequently turn darker in colour.

The collapse of large blocks of dolomite within the Name Chamber feeding shaft results in a complex interlocking sequence of obstructions which, in turn, results in the filtration of material as it passes through the shaft; larger materials become blocked and smaller grained sediment is allowed to pass into the chamber. The uniform maximum size of the blocks of dolomite and chert (approximate maximum length 150mm) that are sorted into one thick lens on the eastern wall demonstrates the process of filtration taking place in the Name Chamber feeding shaft. It is unknown if remnants of the old brecciated deposit lie at the centre of the current Name Chamber talus. Only further extensive excavation will reveal the depth and true size of the Name Chamber deposits. This process of filtration has significantly influenced the rate of deposition and type of sediment deposited, and may have extensive implications for the deposition of larger archaeological and palaeontological objects.

The old brecciated deposit did not fill the Name Chamber; the upper-most level can be seen preserved in the chamber walls at 16 meters below the base of the feeding shaft. Above this point only Member 1 breccia is preserved on the walls. After the old brecciated deposit ceased to accumulate and was calcified, it was then decalcified and eroded away to lower chambers. The Jacovec Cavern contains remnants of red breccia on its northern walls (directly below the southern end of the Name Chamber) very similar in

matrix colour and degree of sorting to that of the old brecciated deposit of the Name Chamber. Currently, a connection exists between the Name Chamber and the Jacovec Cavern only in theory, although Dr. Bruxelles and Prof. Clarke are both positive of their relationship given their proximity and infill patterns.

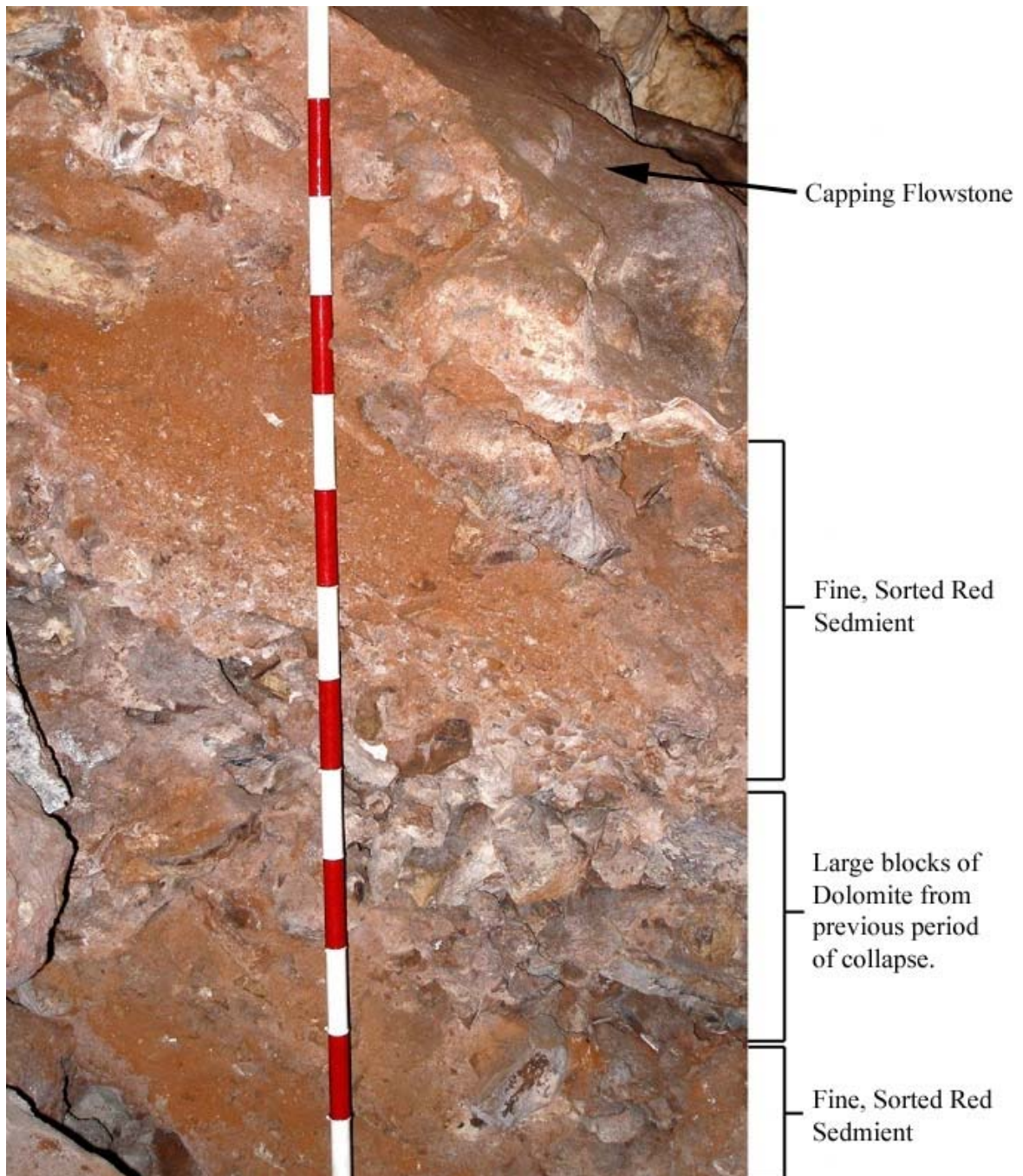

Figure 5.2. Preserved profile of the old brecciated deposit on the far eastern wall of the Name Chamber. Notice the sorting of sediment size within the deposit indicating the presence of water during deposition and calcification. The range staff is calibrated in 100mm segments.

III. The younger 'soft' deposit

The deposit currently excavated for this study is different in nature to the other deposits in the Name Chamber because the sediment has never calcified; it has remained 'soft'. The presence of calcite crystals and their increase with progressive depths within the soft matrix indicates that calcification has commenced within the deposit and would be likely to increase with time.

The younger 'soft' deposit can be identified in three locations:

1. The Far Western Talus
2. The Western Talus
3. The Eastern Talus

All three deposits were filtered as they entered the Name Chamber through the same feeding shaft that deposited and filtered the old brecciated deposit. Within the three deposits the sediments have been sorted, again indicative of the presence of water during deposition. The Far Western Talus and the Western Talus represent the same infill. The Far Western Talus is of key importance because it has undergone no mixing or disturbance from the Eastern Talus, it deposits into the Milner Hall instead of the Name Chamber, avoiding the influence of the other parts of the deposit. Although all three infills represent deposits forming over a similar period of time, physical alterations within the feeding shaft caused sporadic switches in deposit destination and rate of deposition between the eastern and western sides of the Name Chamber. Above a point 14 meters below the base of the feeding shaft, the two deposits (Eastern Talus and Western Talus) are separated by a huge collapsed block of dolomite, a remnant of collapse caused by the decompression immediately prior to and during the Member 1 depositional period (see above for a description of the ancient brecciated infill). Below 14 meters, the two deposits (Eastern Talus and Western Talus) start to join (see the Western Talus discussion). The nature and interactions of these three deposits are described below. Figure 5.3 presents a vertical view, down into the Name Chamber from the ceiling.

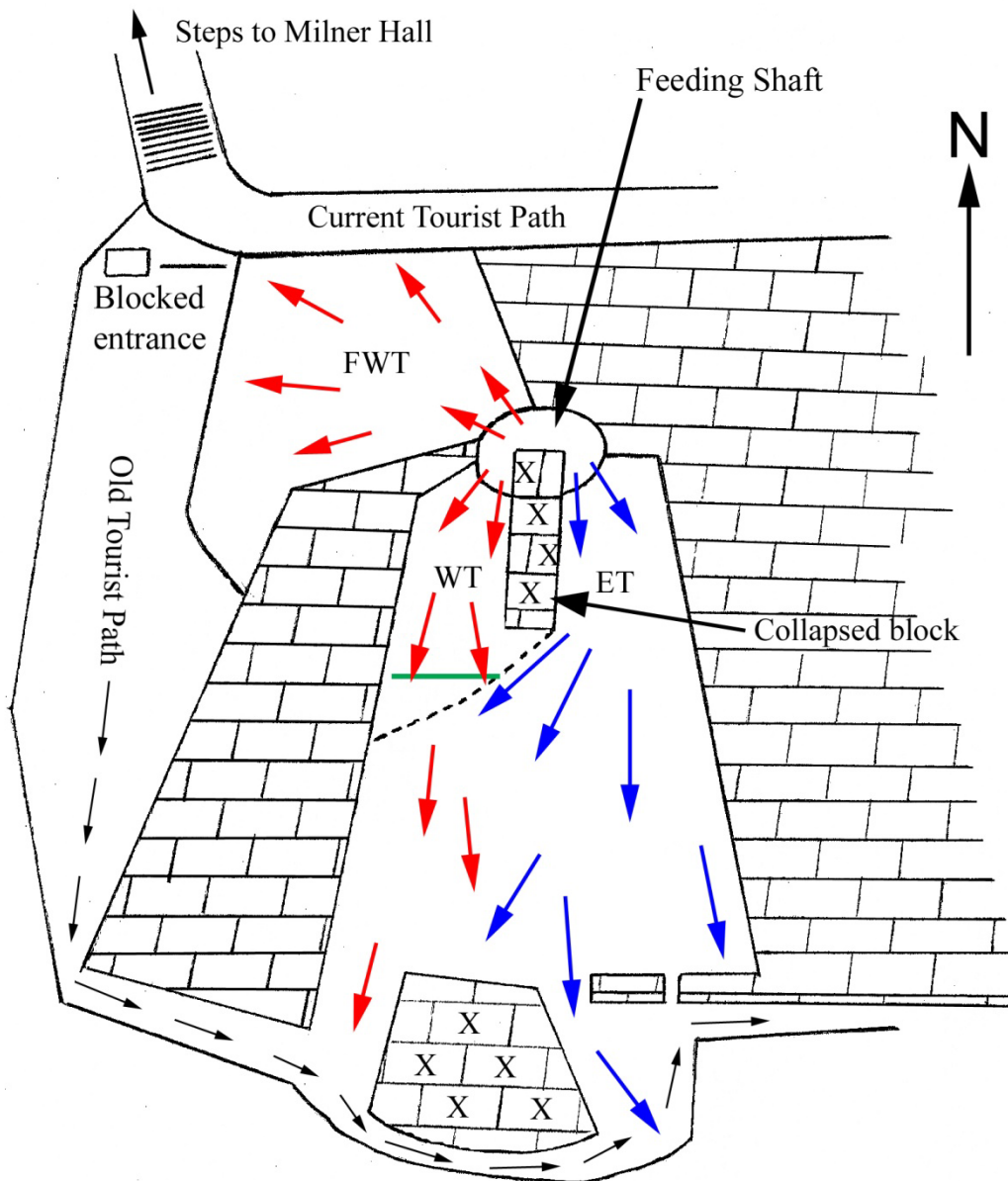
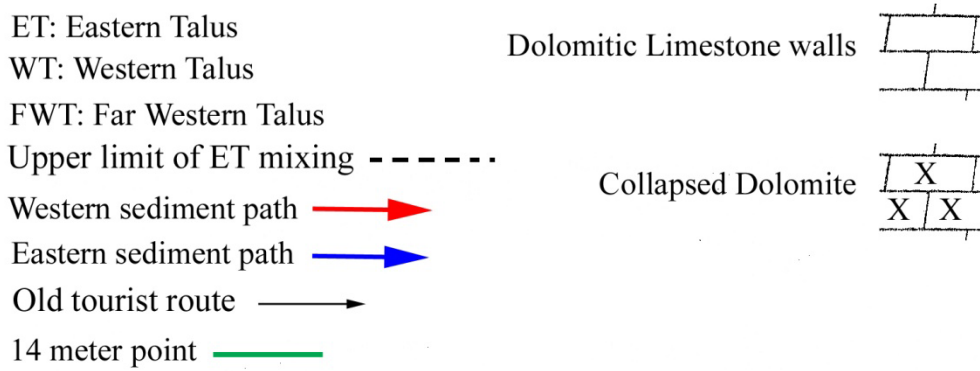

Figure 5.3. Vertical aspect schematic of the younger 'soft' deposits currently filling the Name Chamber. The 14 meter point below the base of the feeding shaft is shown with a green line. Below this point the ET and WT start to interact. The huge dolomite block that separates the ET and WT is labeled 'collapsed block'.

1. The Far Western Talus

This deposit emerges in the south-eastern extremity of the Milner Hall (Figure 5.4). The deposit is described here separately because it is unmixed and displays an excellent example of the younger Name Chamber talus development and stratigraphy but, as mentioned above, it is identical to the Western Talus deposit inside the Name Chamber. The lower portion of the talus was removed by the lime-miners in order to access the calcite deposits within the Name Chamber. The same route was later used as the old tourist path which passed through the Name Chamber, around the base of the talus. The truncation of this deposit has exposed approximately 1.5 meters of a well-preserved depositional profile.

Clear stratigraphy can be seen in this profile and lenses of different sediment colour, consistency and clay content run through the deposit (Figure 5.4 and Figure 5.5). These lenses of darker, lighter, clay or stone-dominant sediment indicate different surface conditions supplying sediment for deposition. Sediments within the Far Western Talus are well sorted and lack large blocks (>50mm max length) of dolomite or breccia (Figure 5.5). This pattern of deposition of only finer sediments is mimicked in the upper portion of the Western Talus and indicates high levels of filtration taking place in the feeding shaft during the deposition into the western side of the chamber. Calcite crystals can be seen in this profile at levels below 10-15cm from the surface of the deposit. The top levels of the deposit are still regularly mixed by sediment movement which hinders calcification. Larger blocks of dolomite and breccia can be seen on the surface of the upper parts of the talus, having collapsed from the ceiling (Figure 5.4). The Far Western Talus has not been affected by the introduction of very recent sediment and water that entered the chamber when the shaft was re-opened in 1994 by Prof. Clarke. The Western and Eastern Tali within the Name Chamber were more heavily influenced by this process.

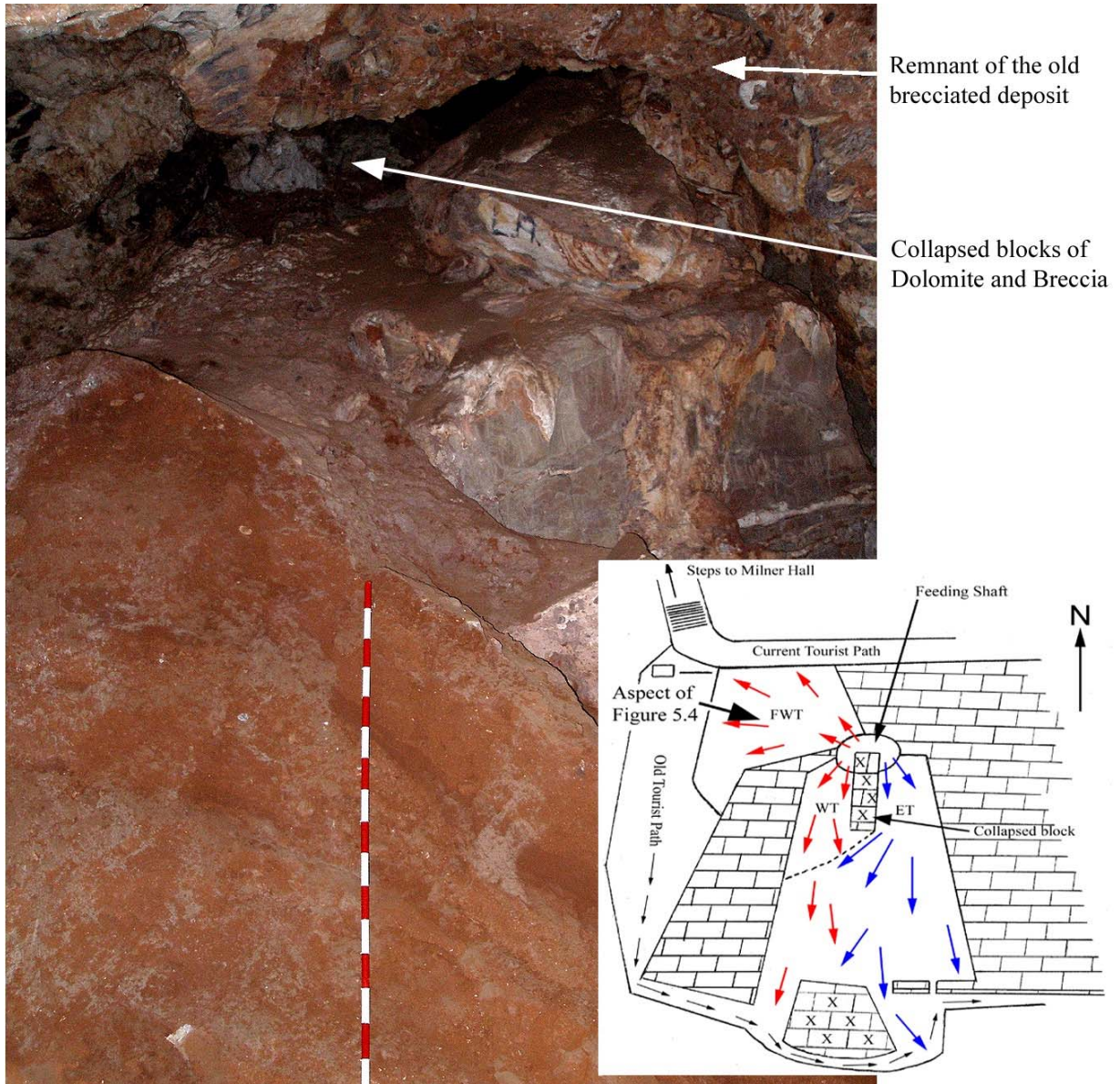

Figure 5.4. The Far Western Talus emerging from the Name Chamber into the Milner Hall. Note the remnants of the old brecciated deposit adhering to the ceiling. The range staff is calibrated in 100mm segments.



Figure 5.5. Stratigraphy within the younger 'soft' deposit of the Far Western Talus. The range staff is calibrated in 100mm segments.

2. The Western Talus

The Western Talus portion of the deposit is restrained within the Name Chamber itself. At the base of the western opening of the feeding shaft the Far Western Talus and the Western Talus diverge, separated in their deposition by the western wall of the Name Chamber (See Figure 5.3). The Far Western Talus and the Western Talus deposits formed from the same source of sediment over the same time period. The Western Talus below 14m from the base of the feeding shaft has received regular ingresses of varying quantities of material from the Eastern Talus (Figure 5.6). The influence of the Eastern Talus on this deposit has removed much of the stratigraphy that is still visible in the Far Western Talus. The excavations, methods and logistics of excavation in the Western Talus have been discussed in Chapter 3. The sediment deposited into the Western Talus is significantly finer in grain size than that deposited in the Eastern Talus. The contact of the two sediments can be seen in the northern wall of Ex1 and the northern wall of the geological section (Figure 5.6) which provides an east to west profile one meter long and one meter deep, 14m below the base of the feeding shaft. Finer sediment from the western talus was present to a depth of 40cm before the stonier sediment joined from the Eastern Talus. Figure 5.7 shows the geological section and the ingress of stonier material from the Eastern Talus in relation to the two tali. This stonier sediment runs to an unknown depth because the geological excavation was halted due to potential collapse. The geological profile serves to demonstrate the successively changing nature of the sediment source from a single feeding shaft and the different filtration processes that influence the type of sediment deposited. A large quantity of stonier sediment was deposited into the Name Chamber when the Eastern Talus was the primary source of sediment. The western side of the feeding shaft then became the primary depositional source and only finer sediment was deposited over the stony sediment, creating the lower Western Talus that we see today. Figure 5.11 presents the profile of the Western Talus, the geological features, the positions of the remnant deposits and the archaeological excavations.

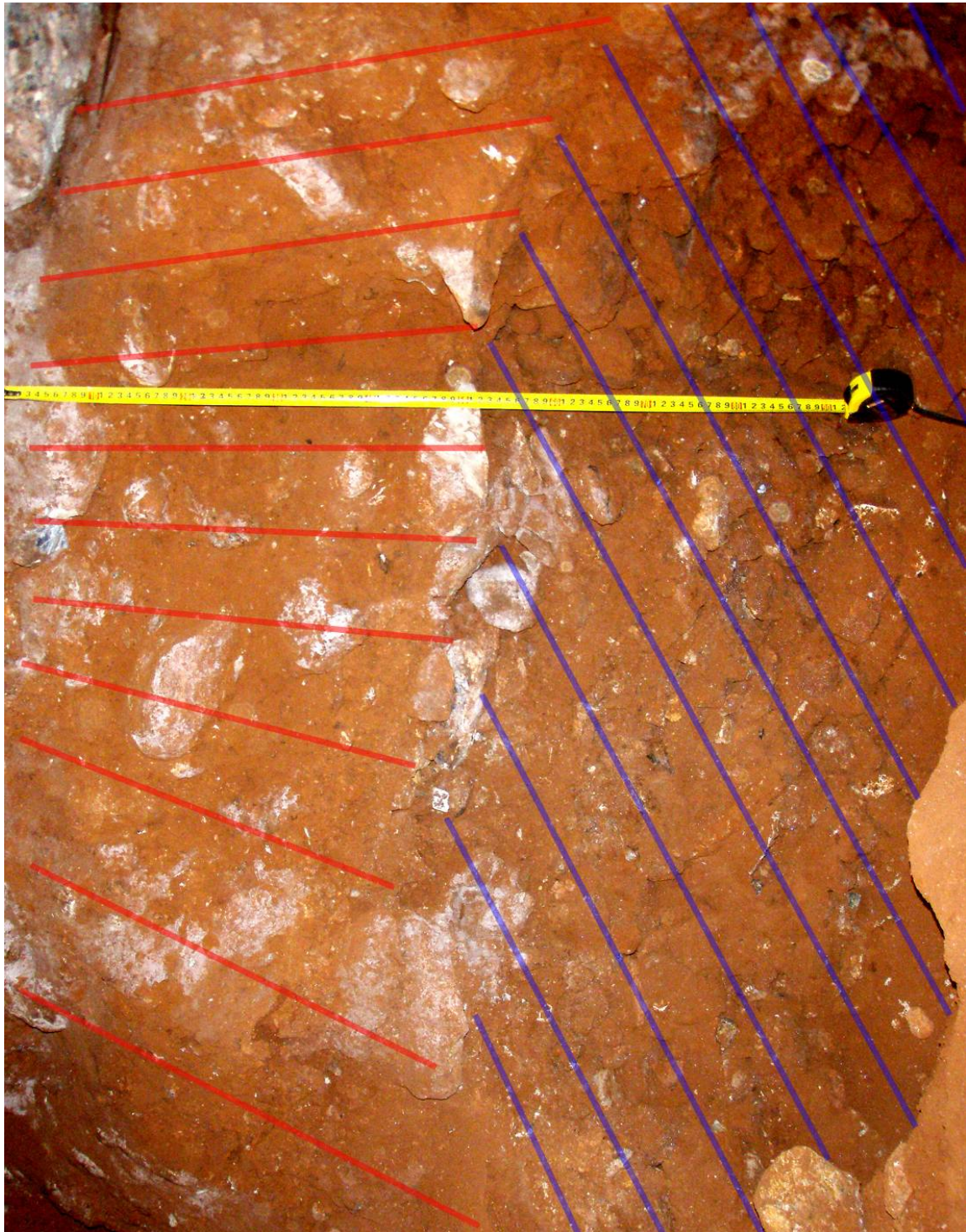

Figure 5.6. Geological section cut into the Western Talus, showing an east-west profile one meter long and one meter deep. The blue strokes indicate the direction of the ingress of the Eastern Talus stonier material. The red strokes indicate the direction of deposition of the overlying finer Western Talus sediment. The tape measure is extended 1 meter. Figure 5.7 shows the geological section in relation to the Eastern and Western talus.

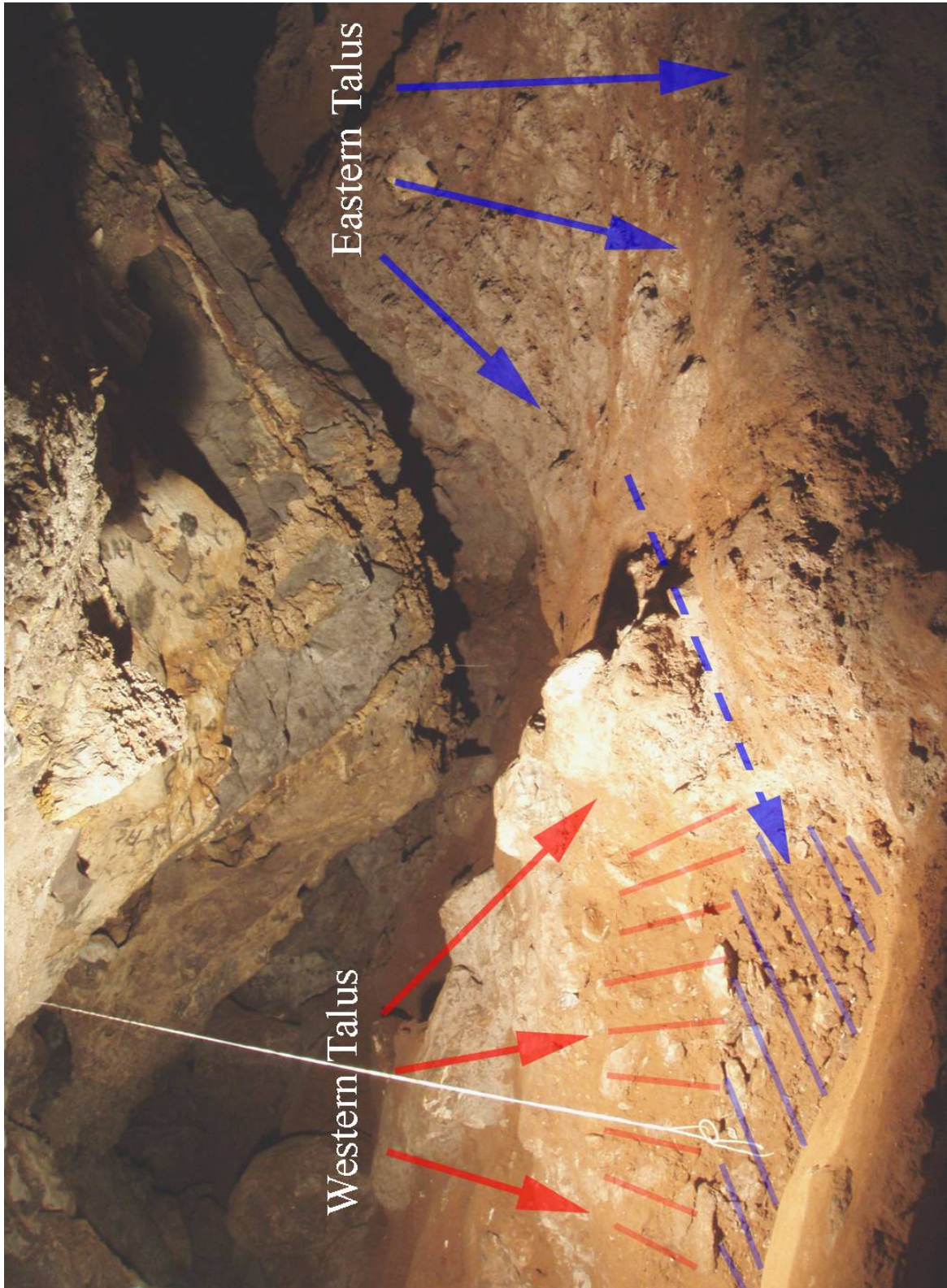

Figure 5.7. Northern aspect. Image of the Western and Eastern talus converging below the 14m point. Notice the geological section in the bottom left corner, the blue arrows and strokes indicate the ingress of Eastern Talus stonier material. The red arrows and strokes represent the overlying finer Western Talus sediment.

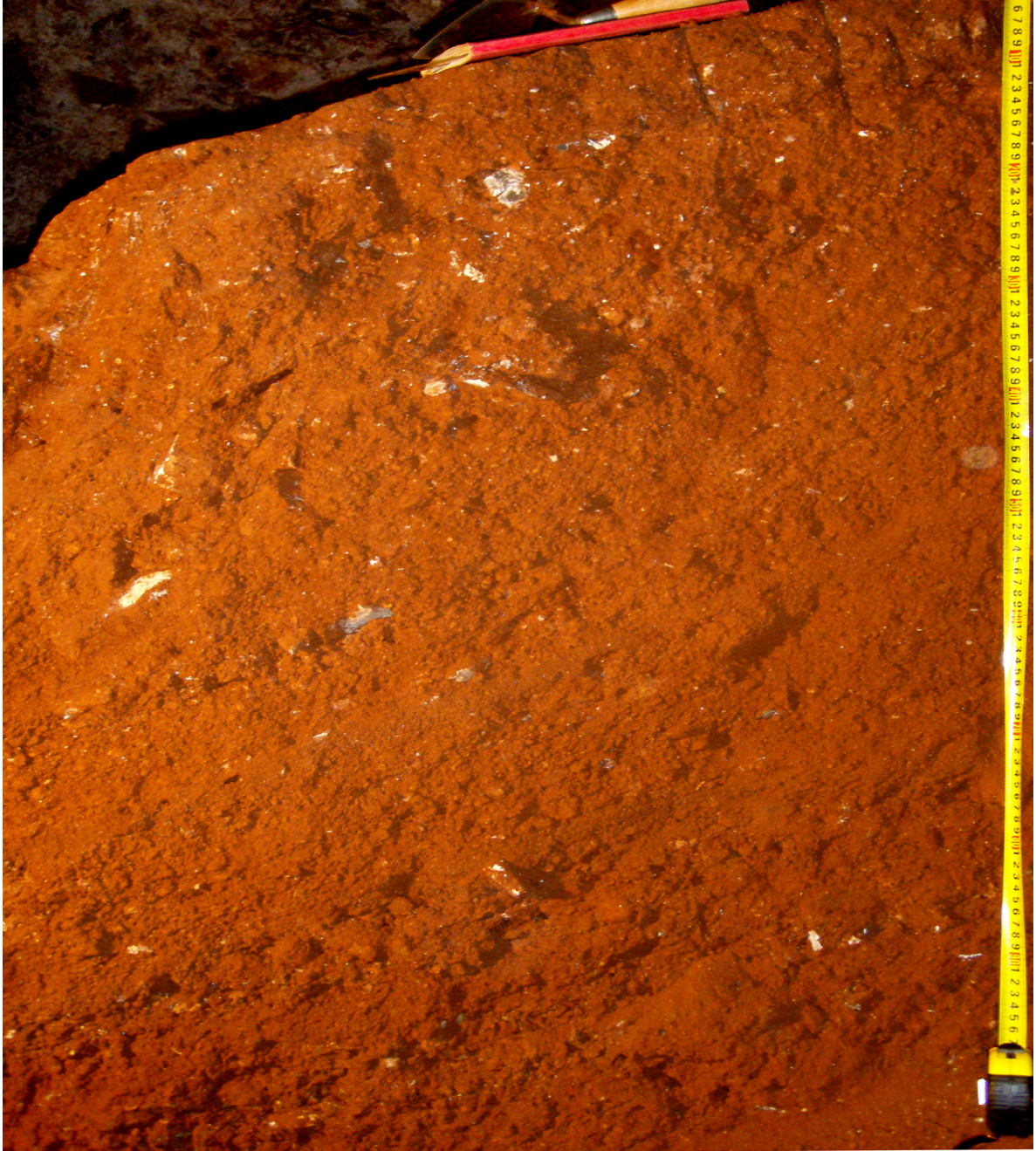

Figure 5.8. Profile of the western wall of Excavation 1 (Ex1). Stratified lenses of slightly differing sediment size follow the gradient of the talus slope from the upper right corner to the lower left corner. Notice the fineness of the sediment in comparison to the sediment in the deeper parts of the geological section. The tape measure is extended 1 meter.

The excavations on the Western Talus have sampled the finer sediment closer to the surface, with only the bottom spits of Ex1 sampling the stonier sediment from the Eastern Talus. Figure 5.8 shows the western wall of Ex1 (4 meters above the geological section). The contrast between the matrix in the Figure 5.8 and the blue stroked level of the geological section (Figure 5.6) can clearly be seen. Stratigraphy within the finer sediment of the Western Talus can also be seen in the western wall of Ex1, as well as in the profiles of all the excavated areas, but it is clearest in Ex1, the largest of the excavations.

3. The Eastern Talus

The Eastern Talus is currently un-sampled, which leaves the internal structure of this side of the Name Chamber uncertain. Ingresses of material from the Eastern Talus into excavated areas of the Western Talus have been sampled and micro-fauna and taphonomic samples are being analysed to assess any possible differences between the two deposits. What can be seen from the geological section (Figure 5.6) is that the eastern side of the feeding shaft is less blocked, which allows larger material (stone, bone and coarser sediment) to be deposited into the Name Chamber. This process is demonstrated by the clearly stonier material that has been deposited from the Eastern Talus into the western side of the Name Chamber (Figures 5.6 and 5.7). As discussed in the description of the Western Talus, the presence of stonier material is indicative of a lower level of filtration occurring within the feeding shaft.

The present Eastern Talus is significantly larger than the Western Talus and is currently the primary destination of the sediment coming from the feeding shaft. This is indicated by the water damage and modern sediment that has infiltrated the Name Chamber since the feeding shaft was opened briefly from the surface in 1994. There are troughs cut into the soft surface sediment by water entering with summer rains, occurring only on the Eastern Talus (Figure 5.9). The extent of the stonier material from the Eastern Talus deposited into the western side of the Name Chamber indicates that the Eastern Talus has been a recurring destination for sediment in the past, and that deposition quantities have varied. The current Eastern Talus is covered by a thin layer of fine sediment and dust, but below this surface layer the talus is made up of comparatively

stonely sediment to an unknown depth. It is currently unknown if the most recent level of filtration, that which allowed the deposition of the current talus surface, has always operated in this manner. It is possible that the current state of filtration has been operating since the commencement of the deposition of the younger 'soft' sediment. This is, however, unlikely given the regular collapses of walls and ceilings within these cave systems. It may be that the sediment deposited into the Eastern Talus in the past was finer and underwent more intense filtration in the feeding shaft than is evident at present. Without deep sections excavated into the Eastern Talus the internal stratigraphy and depositional trends of this side of the feeding shaft will remain open to speculation.

The shaft has since been blocked by a collapse at the surface that has prevented further erosion of the talus or ingress of material. The shaft had been open to the surface for about a year before this collapse occurred and blocked the entrance. Due to these months of exposure, however, the surface sediment to a depth of 30cm in the Eastern Talus should be regarded as contextually compromised and heavily mixed.

The Feeding Shaft

The internal structure of the feeding shaft is only known from the description of speleologists Moen and Keyser who descended through the shaft into the Name Chamber from the surface excavation in 1994 (Clarke 1994). Since the surface entrance has been closed, no further explorations of the shaft have been possible. The published description of the shaft is given in the Literature Review. The little information there is, however, is exactly what one would expect given the depth and depositional properties of the shaft. Moen and Keyser described passing through a large quantity of decalcified breccia in the upper parts of the shaft and then through a section of large interlocking dolomitic blocks.



Figure 5.9. Northern aspect of the Eastern Talus from approximately 12m below the base of the feeding shaft. Notice the modern water damage to the surface to the talus. Also notice the huge block of dolomite in the bottom left which splits the Western and Eastern Talus.

The feeding shaft transects the deeper sections of the Member 5 East deposit. Other members could be also transected but their position in relation to the feeding shaft is as yet unclear. Further exploration of the feeding shaft is needed to clarify this. The feeding shaft opens into the current surface of the main excavation in grid square R/57. Figure 5.10 presents the position of the feeding shaft and the outline of the Name Chamber deposit under current main excavation. The shaft was originally formed in the dolomite floor of the above chamber through locally concentrated aggressive water action. This water, with low calcium concentrations, decalcifies the breccia walls of the deposit the shaft passes through and brings sediment into the Name Chamber. The large interlocking dolomitic blocks have provided the filtration system that operates on the material that is deposited into the shaft. It is still unclear as to how much archaeological material has been trapped within the filtration system of the feeding shaft. In theory, if the Eastern Talus side of the feeding shaft inflicts less filtration than the Western Talus, as seen in the larger average size of deposited sediment from the Eastern Talus, then larger archaeological artefacts may have been deposited into the Eastern Talus. In contrast the Western Talus side of the feeding shaft seems to have a greater level of filtration acting upon the sediment descending the shaft, and so one could expect the larger archaeological artefacts to be trapped during the active deposition into the Western Talus. Only excavations into the Eastern Talus will reveal how this variable filtration influences the deposition of archaeological material.

As can be seen from the above descriptions of the Name Chamber deposits there are intermittent changes in the dominant deposit destination. This process is caused by the collapse of supporting blocks within the feeding shaft, changing the morphology of the shaft and thus the destination and component size of the sediment. From observations of the Name Chamber deposits the feeding shaft has switched deposition side at least four times, each for different lengths of time and depositing different quantities of material. These depositional trends occur over very long periods of time judging by the size of the deposits formed in the Name Chamber. Deeper excavations may uncover more switches within the feeding shaft from east to west.

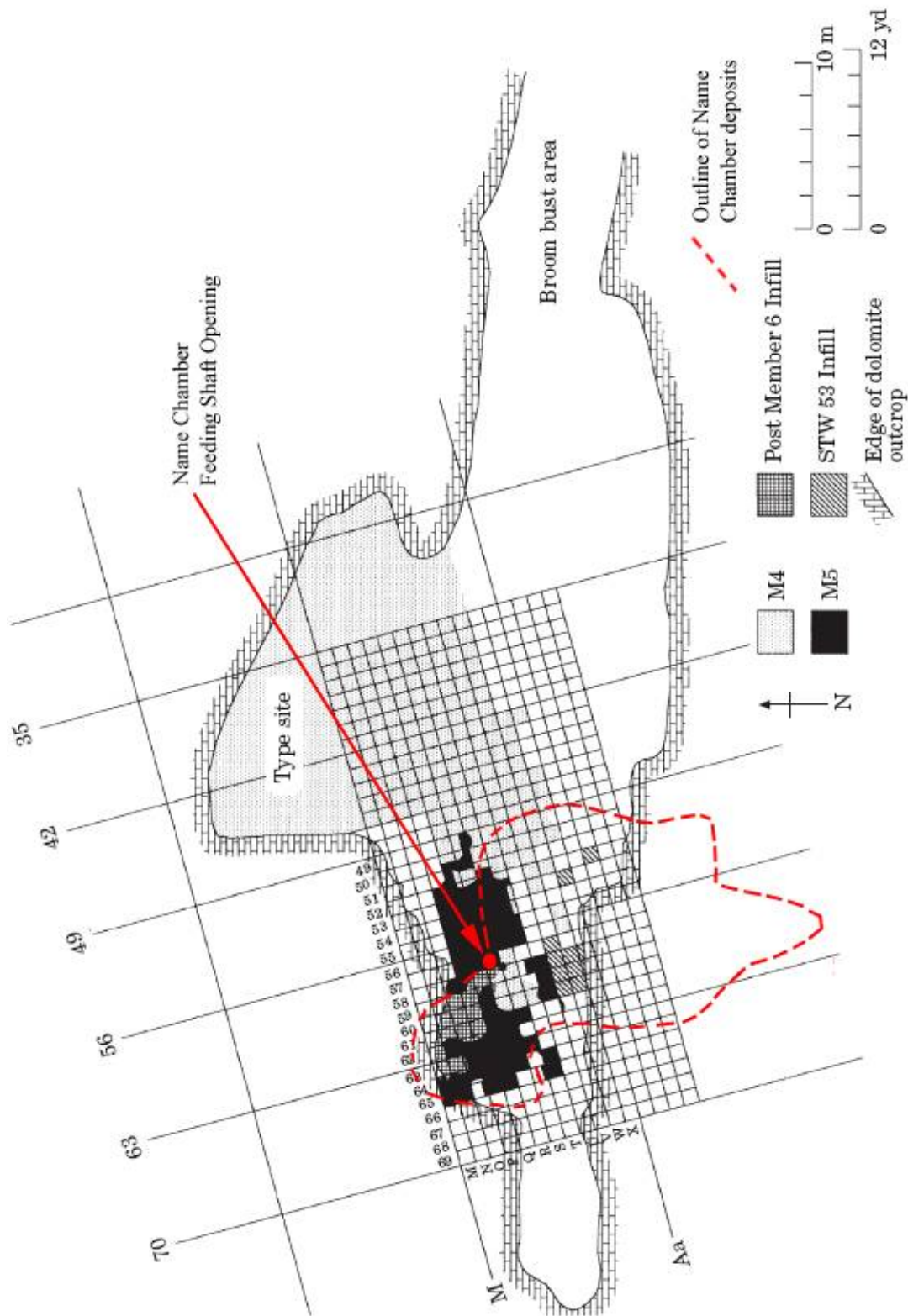

Figure 5.10. The main Sterkfontein excavation with position of the Name Chamber feeding shaft opening into the Member 5 deposit. The dashed red line represents the boundaries of the Name Chamber deposits beneath the main excavation.

5.1.2. Stratigraphic Conclusions

The following sequence of events can be suggested for the formation of the Name Chamber deposits from the evidence presented above.

1. The 1st deposit (Member 1) was formed during and immediately after the decompression of the cave system. Calcium rich water and fine sediment entered through fractures in the dolomite ceiling, cementing the collapsed blocks and manganese rich soil and filling the Name Chamber. Much of this 1st deposit was later decalcified and eroded by water to lower levels. This could happen through a rise in the water table, aided by slightly acidic water penetrating from above when the cave opened more fully to the surface. Remnants of this Ancient Brecciated Infill still adhere to the ceiling of the Name Chamber.
2. The 2nd infill, the 'Old Brecciated Deposit', entered. The depositional profile preserved on the eastern wall of the Eastern Talus indicates that this deposit was fed by the already open feeding shaft. This infill needs further investigation to determine if it is equivalent to Member 2 or 3. It is an iron-rich (red) sediment derived from the surface, filling the Name Chamber to about half full. High levels of sediment sorting indicate that water was involved in the deposition of this sediment in the Name Chamber.
3. The shaft then blocked, and calcium-charged water dripped from the ceiling to calcify the deposit. Member 4 was deposited in the chamber above, and later, portions of it must have collapsed into the Name Chamber (Clarke 1994).
4. This collapse could have been caused by events that led to the decalcification and erosion of the Old Brecciated Deposit, such as water percolating from above and rises in the water table.
5. Member 5 was then deposited in spaces in the upper chamber left by the collapse of Member 4 (Clarke 1994). Eventually, erosion of material blocking the shaft linking the upper and lower chambers occurred, and Member 5 sediments were re-deposited in the Name Chamber.
6. As the feeding shaft was periodically open to filtering of material from above, sediments continued to enter the Name Chamber but were at times subject to sorting within the shaft. Calcification of the visible portions of the talus has occurred in areas that have experienced drip within the chamber.

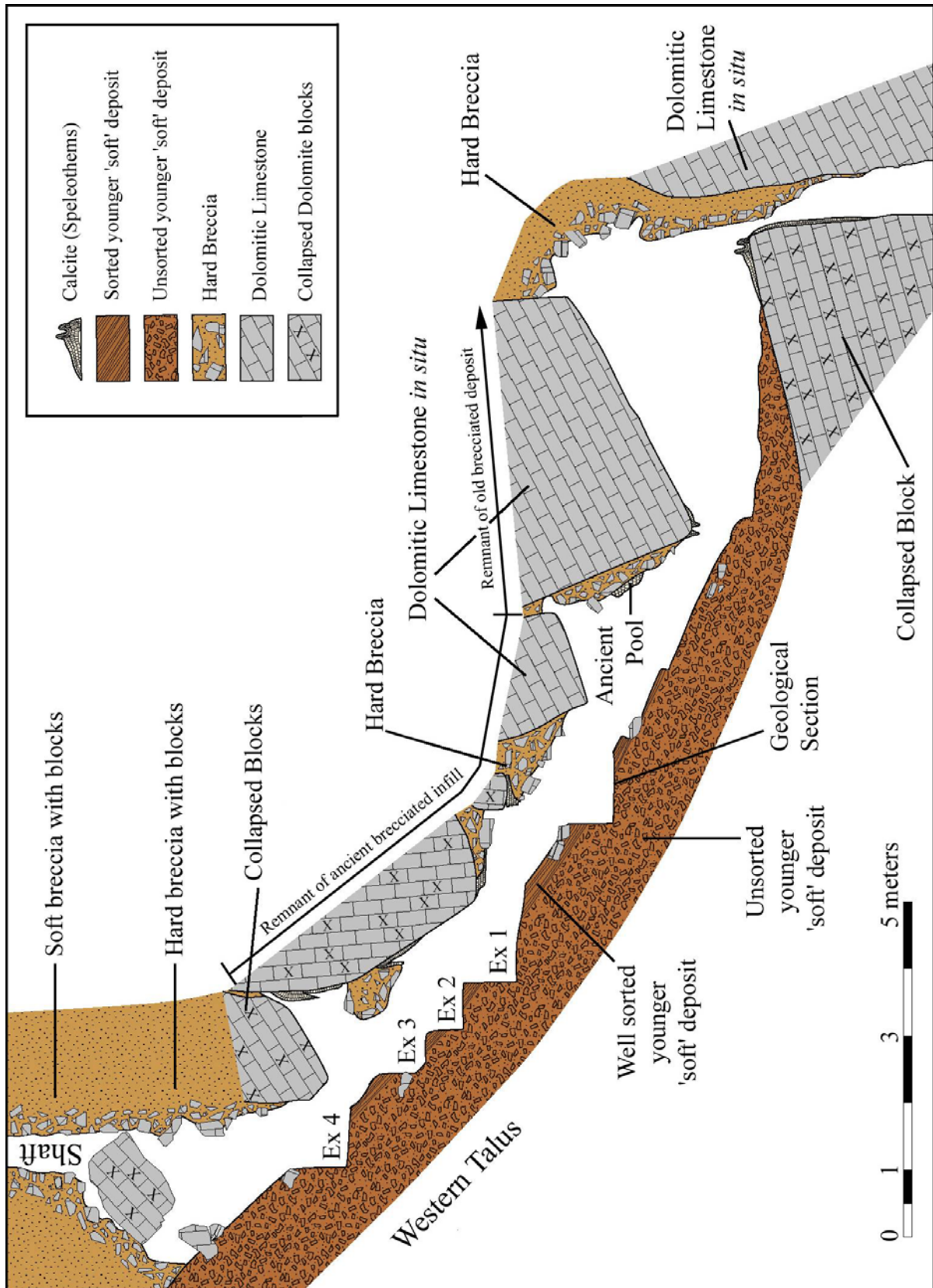

Figure 5.11. Profile of the Western Talus including excavations. Note that the breccia within the feeding shaft walls is mixed - containing remnants of both hard breccia deposits and soft sediment from the younger 'soft' deposit.

5.2. Name Chamber Archaeology.

Introduction

The current Name Chamber artefact assemblage has been excavated in two sessions. The first part of the collection derived from a small exploratory pit dropped into the area that is now part of Ex1 (see Chapter 3 – Methodology for excavation plans and description). This excavation was carried out during 2000 (see Chapter 3 for the detailed dates). Prior to this test pit the only artefacts recovered from the Name Chamber were three large pieces removed by Robinson from the decalcifying breccia adhering to the walls in the base of the feeding shaft above the summit of the talus (Robinson 1962)(see Figure 5.30 for an illustration of these artefacts). Robinson did not attribute these artefacts to an industry but associated them with ‘disturbed middle breccia’. Unfortunately the exact location of these artefacts was never published. The Eastern Talus summit is very difficult to climb or conduct any detailed inspection making the Western Talus, which is much easier to climb and has large quantities of material from the younger ‘soft’ deposit in the fissures of the feeding shaft walls, the probable source of these artefacts. The second part of the collection was excavated from 2006-2007 (see Chapter 3 for the detailed dates) and covered a much greater area of the Name Chamber Western Talus. The safety issues and logistics that restricted and shaped the excavations are discussed in Chapter 3. As mentioned, the excavations were restricted to the Western Talus and steps had to be cut into the talus to allow safe access. The material from both excavations and the step cutting has been analysed including further samples that were gathered from the Lower Talus (just above the old tourist path) and a sample of 42 artefacts whose context was lost during the 2000 excavations.

Contextually the Name Chamber assemblage is similar in nature to the Dump 21 assemblage in that it has been removed from its original secondary context and re-deposition into the Name Chamber, the difference being the method of re-deposition. In the case of the Dump 21 material it was removed by artificial agents and re-deposited in a single area. The deposition of the Name Chamber artefacts was achieved by natural processes and over a much longer period of time and over a greater area. In the previous section the stratigraphy and formation of the Name Chamber infills has been discussed and a more accurate interpretation of the deposits, and how they formed, has been presented. It

is clear from this stratigraphy that the younger 'soft' deposit was accumulated through the feeding shaft. As discussed, the feeding shaft may transect Members 4 and 5 East depositing material from these members into the Name Chamber younger 'soft' deposit. Currently only Member 5 East has yielded artefacts; an Oldowan industry in the main excavation (beneath 22 feet below datum) and an Acheulean industry from above the Oldowan deposit. The details of these assemblages are provided in the literature review and methodology. Clarke has postulated that the assemblage composition of the Name Chamber collection fits the missing winnowed material from the Member 5 East Oldowan (Clarke 1994). In order to accurately find the provenance of the archaeology recovered from the Name Chamber, comparisons need to be made between the two possible source assemblages, the Oldowan and Early Acheulean. These comparisons will be made in the later sections of this analysis.

5.2.1. Assemblage Overview

The present Name Chamber assemblage consists of 1049 artefacts. Of the 1049 pieces a total of 957 artefacts (91.2%) measure from 0-19mm leaving only 92 artefacts (8.8%) measuring ≥ 20 mm in maximum length. The number of artefacts measuring less than 0-9mm in maximum length is 568 and represents 54.1% of the total assemblage, leaving 389 pieces measuring 10-19mm (37%). A Name Chamber assemblage types and size profile is presented in Tables 5.1 and 5.2. Quartz provides the dominant raw material in the assemblage at 89.6% of the total. Chert (8.8%) and quartzite (1.5%) contribute to the rest of the assemblage with only one nodule of ochre representing different raw material (0.1%). The assemblage is dominated by small flaking debris, representing 91.2% of the assemblage. Of the 92 artefacts measuring ≥ 20 mm maximum length, 7.7% are flakes, with less than 1% (0.8%) representing cores or manuports. The ≥ 20 mm artefacts show a mean maximum length of 30mm and a median of 25mm (mode 21mm). The mean maximum length is influenced by the presence of the cores which will be discussed in the section 5.2.3. The size profile of the assemblage is one of the most important characteristics of this assemblage, only four artefacts measure >50 mm. Eight pieces have been classed as indeterminate, as they show partial diagnostic features and can only be

classified as debitage. Figures 5.12 and 5.13 present the size distribution data and the artefact condition through size category data.

Artefact Types	Quartz	Chert	Quartzite	Other	Total	%
Small flaking debris <10mm	537	29	2	-	568	54.1
Small flaking debris 10-19mm	363	23	3	-	389	37.0
Small flaking debris <20mm	900	52	5	-	957	91.2
Incomplete flakes ≥20mm	15	19	4	-	38	3.6
Complete flakes ≥20mm	9	9	3	-	21	2.1
Flake fragments ≥20mm	9	7	1	-	17	1.6
Core Maintenance						
Flakes	-	-	-	-	-	
Cores	-	1	1	-	2	0.2
Core fragment	-	-	1	-	1	0.1
Core tools	-	-	-	-		0
Manuports	-	-	1	1	2	0.2
Chunks	1	2	-	-	3	0.3
Indeterminate	7	1	-	-	8	0.8
Total	941	91	16	1	1049	100
%	89.6	8.8	1.5	0.1	100	

Table 5.1. Artefact types and raw materials for the Name Chamber assemblage.

	0-9mm	10-19mm	20-25mm	26-30mm	31-35mm	36-40mm	41-45mm	46-50mm	>50mm	Total
Quartz	537	363	24	11	2	1	1	1		941
%	51.2	34.6	2.3	1.0	0.2	0.1	0.1	0.1		89.6%
Chert	29	23	15	9	7	6	2		1	91
%	2.8	2.2	1.4	0.9	0.7	0.6	0.2		0.1	8.8%
Quartzite	2	3	2	3	0	2	1		3	16
%	0.2	0.3	0.2	0.3	0.0	0.2	0.1		0.3	1.5%
Other	0	0	0	0	0	0	0	1		1
%								0.1		0.1%
Total	568	389	41	23	9	9	4	2	4	1049
%	54.1	37.0	3.9	2.3	0.9	0.9	0.4	0.2	0.4	100.0%

Table 5.2. Name Chamber assemblage size profile.

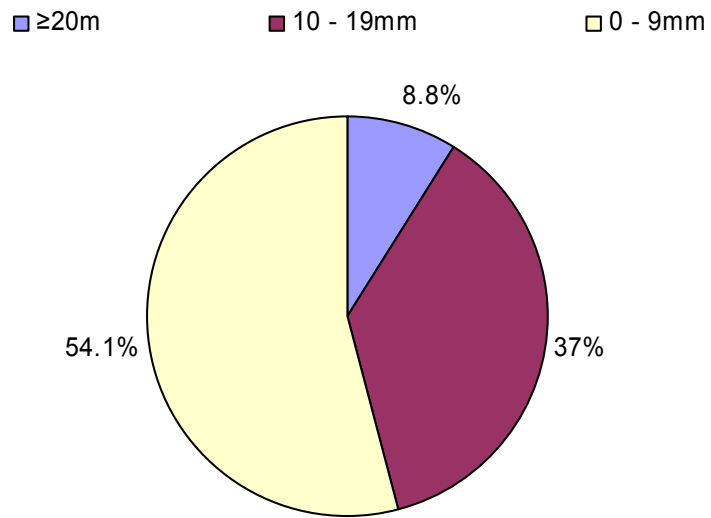

Figure 5.12. Name Chamber artefact size category proportions.

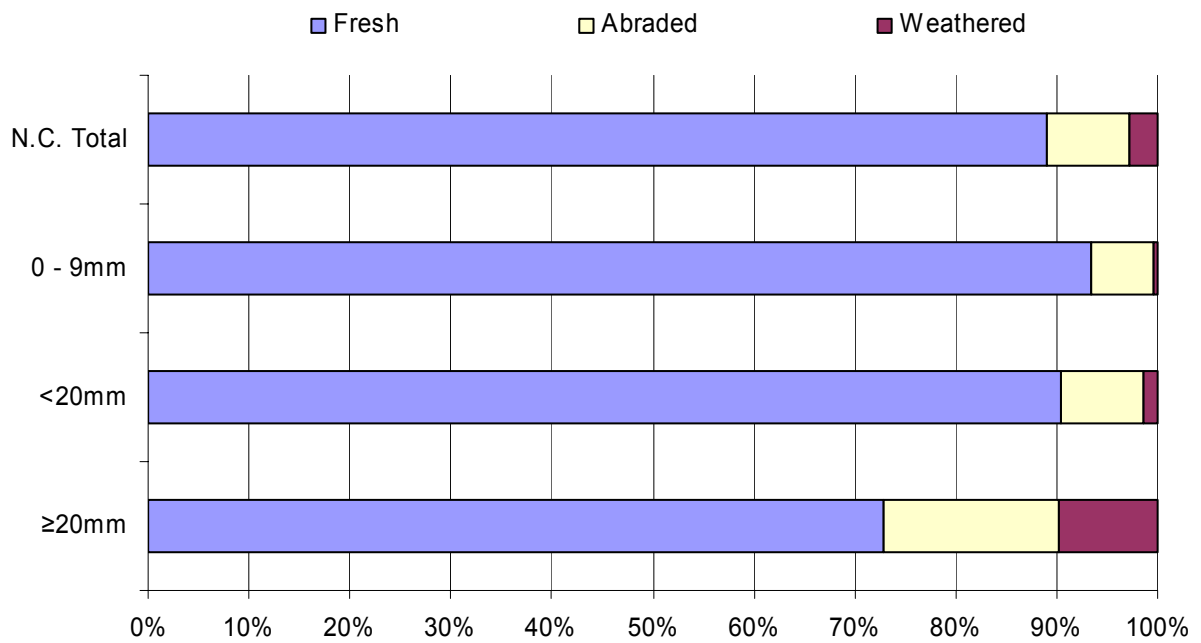

Figure 5.13. Name Chamber artefact condition.

5.2.2. Raw Material Use and Selection

The dominance of quartz as a raw material for the making of stone tools is well documented during the Oldowan at Sterkfontein (Kuman 1994a, 2000, 2003; Kuman et al. 2005; Kuman and Field 2008). Quartz is obtained from cobbles from the river gravels close to the site, as well as from veins weathering out on the landscape. It provides large numbers of small, sharp flakes of varying size with relative ease. The durability of the quartz flake edge is short when compared with the quartzite that dominated the Acheulean assemblage at Sterkfontein. The Sterkfontein landscape in the immediate vicinity of the cave openings is rich in chert weathered from layers that occur within the dolomite. Chert pieces can be found on the landscape and in gravels within 300-500m of the site. These two materials are the most abundant and easy to source without venturing to the river gravels although the quartz in the gravels is likely to be of better quality (Kuman and Field 2008). The quartzite used for artefacts in the assemblage can only be sourced from the river gravels. These river gravels, as discussed in the Dump 21 analysis, have ranged in distance from the caves, but never exceeded 500 meters from the Sterkfontein cave system. In an expedient industry, such as the Oldowan, the key characteristic is the utilisation of easily available raw materials. Kuman and Field (2008) found that 72% of pieces with recognizable cortex had river gravel cortex, suggesting a high level of transport of raw materials into the site. In the Oldowan assemblage, which is similarly dominated by quartz, 95.4% of the artefacts are of indeterminate source. This is due to the flaking properties of quartz, where a very large proportion of flakes are produced subsequent to the removal of cortical flakes. Within the Name Chamber assemblage only seven artefacts $\geq 20\text{mm}$ (7.6%) show more than 50% cortex cover and allow positive raw material sourcing. All of these seven artefacts can be sourced to the river gravels.

From the tables above and Figure 5.14 one can see that there is a distinct dominance of quartz (nearly 90%), with chert at almost 9% and quartzite at less than 2% in the Name Chamber sample. Chert cores produce very sharp and numerous flakes in a similar fashion to quartz. These flakes, however, tend to break more easily than similarly sized quartz flakes (personal observation). This fracture dynamic of chert may account for the poor representation in the assemblage, given its high level of availability. The relatively low quantity of quartzite (1.5%) maybe due to the fact that flaking was

performed off site as Kuman and Field (2008) suggested for the Oldowan assemblage. If this is the case then one would expect to see very little quartzite flaking debris on site.

A methodological issue is also apparent when analysing chert flakes. When experimenting with freehand flaking Sterkfontein chert, we found that the key diagnostic features of chipped stone flakes are often missing. Bulbs are often flat, platforms are usually shattered and most distal and lateral portions show step terminations (personal observation from experimentation). This presents a problem when differentiating between artefact and nature-fact in samples excavated from cave deposits, which could include chert from collapsing and weathering walls and ceilings prior to and during the formation of the deposit. In order to avoid mis-classification of natural pieces, only chert flakes displaying one or more diagnostic features were counted and analysed. Quartz, however, is less problematic, because the vein quartz that is sometimes found in cave sediments is easy to distinguish.

One can see from the graphs of the raw material proportions for size classes <20mm (Figures 5.14 and 5.15) that the proportions of quartz to quartzite and chert are consistent with the proportions within the Oldowan assemblage (Kuman and Field 2008); Section 5.2.5 presents the comparative data between the two assemblages. The consistency in proportions through 91% of the assemblage demonstrates a reliable sieving and sorting process during excavation and a consistent artefact classification process. In the raw material profile of the ≥ 20 mm category a marked increase in the proportion of chert is apparent. If the proportions within different size categories of the assemblage were drastically different then a methodological inconsistency in classification would have to be addressed before any archaeological or site formation issues could be suggested.

The consistency of these results in comparison with the Oldowan assemblage allows inferences regarding the raw material proportions in the Name Chamber to be made. First, the consistency of raw material proportions through the size categories indicate that no preferential sorting of raw material within the different size categories has taken place during deposition. Secondly, the uniform patterns of raw material suggest that similar proportions lie within the source deposit of the artefacts. Thirdly, it may be suggested from the two previous inferences that the artefacts that are being deposited into the Name Chamber are weathering from a single artefact-bearing deposit. If two or more artefact-bearing deposits were contributing to the Name Chamber 'soft' infill, then one would expect to see different raw material, artefact condition and size profile signatures in

such a combined Name Chamber deposit, therefore contaminating the raw material proportions within the size categories. The consistency of all these factors through the assemblage suggests that this assemblage can be sourced from one deposit. The $\geq 20\text{mm}$ category accounts for only 8.8% of the assemblage (92 artefacts), and is too small to provide any information on raw material trends in this size category. One can see from the total assemblage statistics that the $\geq 20\text{mm}$ category has a minimal influence on the raw material proportions of the assemblage.

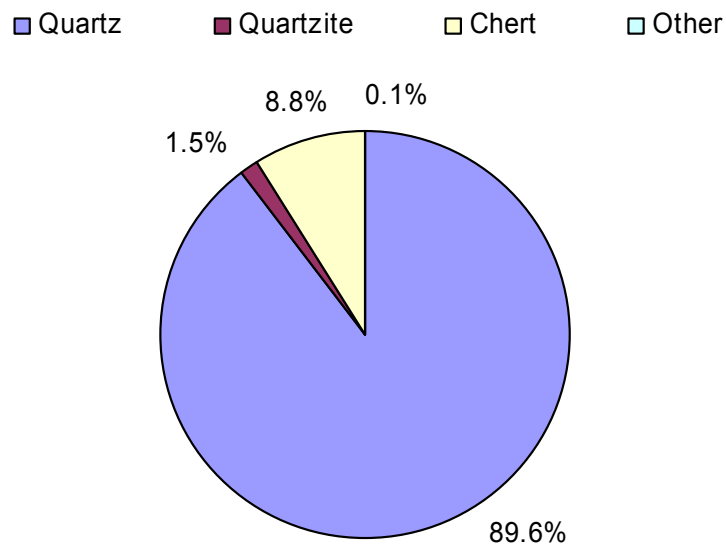

Figure 5.14. Name Chamber total artefact raw material proportions.

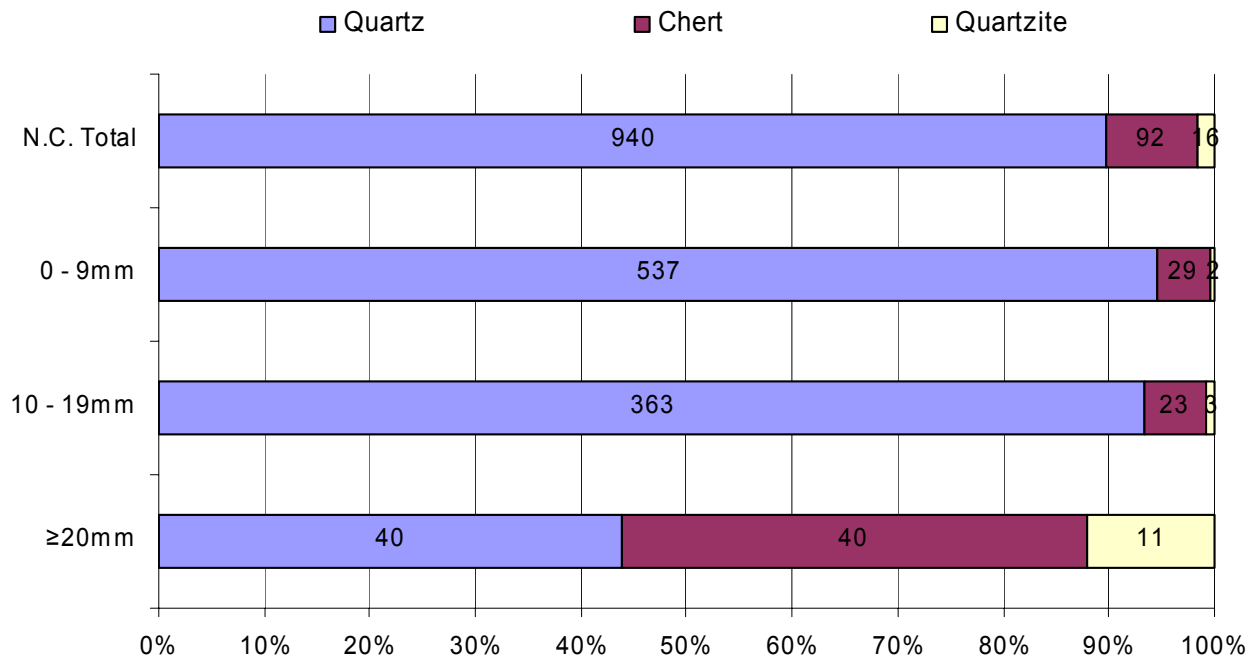

Figure 5.15. Name Chamber artefact raw material proportions per size category.

5.2.3. Core Reduction and Flaking Patterns

Analysis of the cores and flake artefacts recovered from the Name Chamber is limited due to the small data set available. Only three cores (including one core fragment) and 76 flakes (complete and partial) have been excavated. The data available is presented in Tables 5.3, 5.4, 5.5 and 5.6. It should be noted that the small sample size limits any accurate conclusions on technological patterns to be made. Inferences based on this data are only useful when applied in comparison to the larger Sterkfontein assemblages from the Oldowan and Early Acheulean. These comparisons will be made in section 5.2.5.

Cores

Two cores and one core fragment were recovered. The scarcity of cores could be due to the filtration process active in the feeding shaft that accumulates the Name Chamber deposits and sampled from the Western Talus excavation. In the previous section

on Name Chamber stratigraphy and geology, it was stated that the general size of individual blocks of stone deposited into the Name Chamber Western Talus and Far Western Talus did not exceed 50mm maximum length, with the majority of the matrix consisting of fine sediment. This filtration process of material <50mm can be seen in the size profile of the Name Chamber total assemblage. Only four artefacts of the total assemblage measure larger than 50mm, three of which are the cores, plus one of the two manuports. The presence of these cores, which represent only 0.3% of the total assemblage, in an assemblage that has been so well filtered can be seen as anomalous in terms of the depositional trends of the Name Chamber. When the mean maximum length of artefacts measuring ≥ 20 mm is recalculated subtracting the anomalous cores, 27mm is the result, correlating more closely to the mode and median values. In particular, the presence of the largest artefact, measuring 124mm maximum length, is exceptional and may be regarded as resulting from a depositional period characterised by less filtration acting within the feeding shaft. The cores in this collection can only yield limited information as only two are complete. Only one flake scar remains on the core fragment which restricts the available information for this core. The data for the three cores is given in Table 5.3.

Artefact Number	Raw Material	Dimensions (mm)			No. Flake Scars	max scar length (mm)	No. Step Term	Remaining platforms	% cortex cover	Condition (f/SW/W)	Specific Type
		L	W	T							
STK-NC202	Chert	62	43	29	4	18	0	0	0-25	W	Single Platform Core
STK-NC1	Quartzite	124	85	52	4	31	1	2	75-100	W	Chopper Core
STK-NC87	Quartzite	55	31	17	1	20	0	0	0-25	F	Core Fragment

Table 5.3. Artefact data for the Name Chamber cores.

As one can see from Table 5.3, typologically there are two cores, artefact STK-NC202 and STK-NC1 (Figure 5.31). The remaining core is typologically classified as an incomplete core fragment. Technologically all three artefacts represent stone pieces that have been deliberately flaked in order to yield sharp usable flakes. That one piece (STK-NC1) was created to be used as a tool in its own right and another is incomplete (STK-NC87) is irrelevant to the technological intention of the artefacts.

The quartzite artefact STK-NC1 is the only core that has enough cortex remaining to ascertain that the cobble was sourced from river gravels. The cortex is of the rough variety described in the Raw Materials section of Chapter 3, and correspondingly the grain size of the quartzite is coarse. This artefact is typologically classified as a chopper core. The artefact STK-NC1 has been classified as a chopper core because the flake scars that did not terminate in a step or hinge fashion would have yielded workable sharp flakes that may have been utilized, and there is no evidence of utilisation. The classification of stone tools requires one to take all products of the chaîne opératoire into consideration, all potentially usable pieces and debris. The artefact STK-NC1 has been flaked bifacially over the distal end of the elongated river cobble. The proximal end of the cobble has extensive pitting indicating the commencement of the decay of the quartzite. The distal tip of the piece has broken off along a fault in the raw material. The nature of this breakage suggests that it occurred during flaking. Two of the flake scars originated from the tip of the cobble prior to the breakage, as indicated by the presence of the distal termination of the scar, and it may be that the next tip shaping removal then broke the tip off. The limited flaking of the lateral portions of the cobble suggests that the cobble was chosen for its convenient shape prior to flaking. The breaking of the distal tip along natural planes of fracture within the coarse quartzite may have resulted in the discard of this piece.

STK-NC202 is typologically classified as a single platform core as all four flake scars represent removals from a single plane on the flat upper face of the circular fractured chert slab. The four flakes removed from the core have reduced the platform angle on the piece sufficiently and removed the possibility of producing any further flakes. With such a small sample size technological inferences are impossible.

Flakes

The Name Chamber excavations yielded 76 artefactual flakes (Figure 5.32). In order for the pieces to be categorised as a flake, the artefact needed to display one or more of the key diagnostic features discussed in Chapters 2 and 3 (for a complete or incomplete flake or flake fragment) and measure ≥ 20 mm maximum length. For the analysis of the flakes the non-typological approach developed in Sullivan and Rozen's 1985 work has been followed. In order to approach the flakes with a technological methodology, the use of loaded formal typological terminology has been avoided. The flakes have been analysed within these groups whilst looking for correlations across flake categories. Figure 5.16 shows the distribution of the flake categories through the Name Chamber assemblage.

Twenty-one artefacts are classified as complete flakes, representing 2.1% of the total Name Chamber assemblage and 28% of the total flakes. This number is too small to provide any meaningful statistical data or to allow behavioural or technological inferences. Therefore, a description of the flakes and their attributes will be given here. One can see from the data presented below (Tables 5.4, 5.5 and 5.6) that the number of flake scars preserved on the dorsal face of the flake is low, as only nine artefacts (43%) have dorsal flakes scars. This figure is interesting as the quantity of cortex exceeds 50% of the dorsal face on only two artefacts, with the remaining 19 (90%) exhibiting less than 25% of cortex cover on the dorsal face. When low cortex cover quantities are found on flake dorsal faces it frequently correlates with high flake scar counts since flaking facilitates the removal of the cortex. The flaking nature of quartz, however, means that the majority of flakes do not have any cortex, making their source indeterminate. Given the very small sample size of flakes and flakes with cortex it would be misleading to suggest that the quartz was sourced from different provenance than the river gravels (Kuman and Field 2008). Positive sourcing of raw material is possible on only one complete flake (STK-NC181). Quartz flake STK-NC181 has over 75% cortex cover and clearly derives from the river gravels. The high cortex cover correlates with the lack of flake scars and indicates the flake may have been removed in the first phase of the reduction of a quartz river cobble. The relative thickness of the flake (15mm) and the thick platform are characteristic of flakes produced during this phase of reduction. The predominantly fresh condition of the flakes (57% of complete flakes classified as fresh) precludes the elimination of flakes scars through weathering processes. Figure 5.17 illustrates the difference in mean flake dimensions

across raw materials within the complete flake category. It is apparent that, like the small Dump 21 flake sample, the quartzite flakes are longer, wider and comparably thick. The quartzite flake scar quantities and dimensions are comparable to the chert and quartz complete flakes. Due to the small number of quartzite flakes in each flake category it is impossible to determine if the quartzite obtained was flaked more intensively than the other raw materials.

	Length (mm)	Width (mm)	Thickness (mm)	No. Flake Scars	Condition (f/sw/w)	% cortex cover	length max scar (mm)
Mean	28	20	7	0 ^{1,2}	f ^{1,2}	0 - 25 ^{1,2}	16

Table 5.4. Artefact data for the Name Chamber complete flakes. ¹ Median. ² Mode.

The incomplete flakes from the Name Chamber yield similar data to that of the complete flakes. Incomplete flakes represent 3.6% of the total Name Chamber assemblage and 50% of the flakes excavated, the largest proportion of the flake categories. This dominance of the incomplete flake in the flake assemblage is to be expected given the preferred utilisation of the more brittle raw materials chert and quartz. The nature of incomplete flakes means that the data retrieved from the artefact is itself incomplete, the data acquired is still of use for general comparisons within this assemblage, but cannot be used for broader inferences. The incomplete flakes do, however, show a larger proportion of smaller maximum lengths; 17 flakes (44%) measuring <25mm. Twenty five incomplete flakes (66%) exhibit no flakes scars. Of the remaining 13 flakes, ten (26%) exhibit only one flakes scar and the remaining three flakes show two, three and five scars, representing 8% of the incomplete flakes. Figure 5.18 presents the mean flake dimensions per raw material type for the incomplete flake category.

	Length (mm)	Width (mm)	Thickness (mm)	No. Flake Scars	Condition (f/sw/w)	% cortex cover	length max scar (mm)
Mean	29	18	7	0 ^{1,2}	sw ¹	0 - 25 ^{1,2}	19

Table 5.5. Artefact data for the Name Chamber incomplete flakes. ¹ Median. ² Mode.

The flake fragment data bear similar information to the incomplete flake and complete flake portions of the assemblage. Flake fragments represent the smallest proportion of the flake category (n= 17; 22%) and 1.6% of the total Name Chamber

assemblage. The size profile and raw material profile of the flake fragments is comparable to the other flake categories, indicating identical depositional processes and source. Within the flake fragment category quartzite is represented by a single piece, quartz and chert making up the other 16 pieces. Only four of the flake fragments (23%) exhibit flake scars. These scars are distributed evenly between the three raw materials. With only one quartzite flake fragment it is impossible to ascertain whether there are any preferential flaking activities. Figure 5.19 presents the mean flake dimensions per raw material type for the flake fragment category.

	Length	Width	Thickness	Flake Scars	Condition (f/sw/w)	% cortex cover	length max scar
Mean	27	16	7	0 ^{1,2}	sw ^{1,2}	0 - 25 ^{1,2}	15

Table 5.6. Artefact data for the Name Chamber flake fragments. ¹ Median. ² Mode.

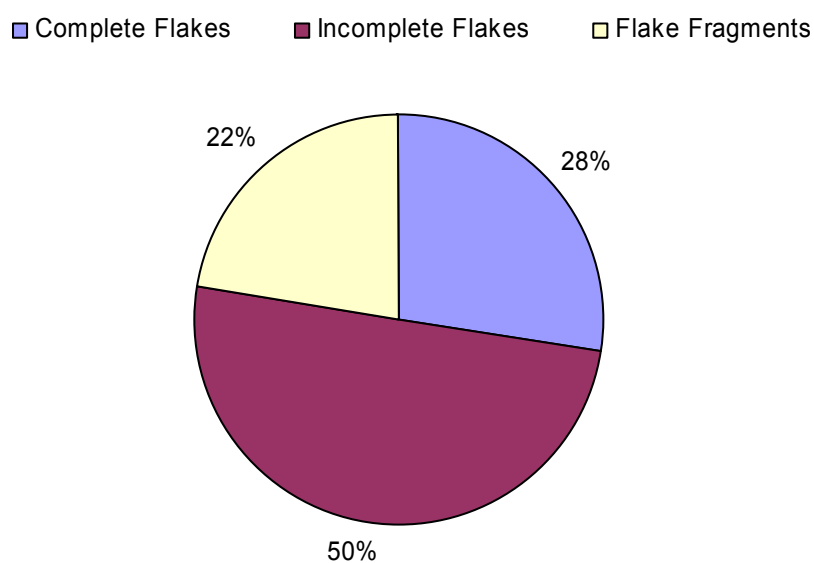

Figure 5.16. Name Chamber flake categories.

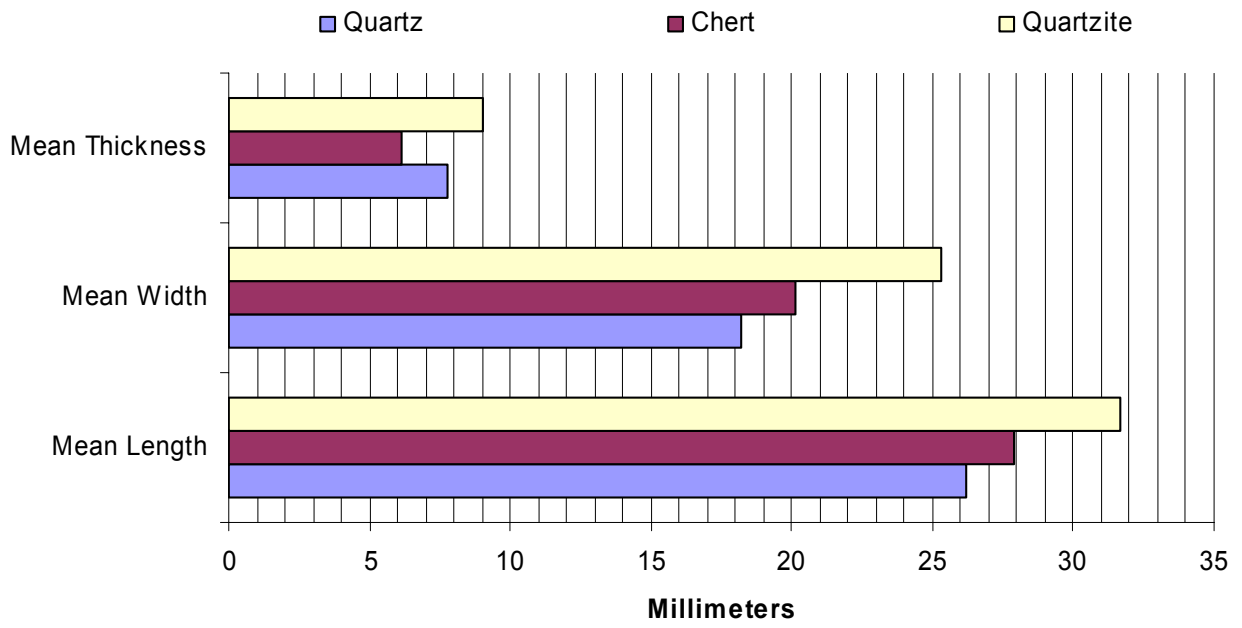

Figure 5.17. Name Chamber mean complete flake dimensions.

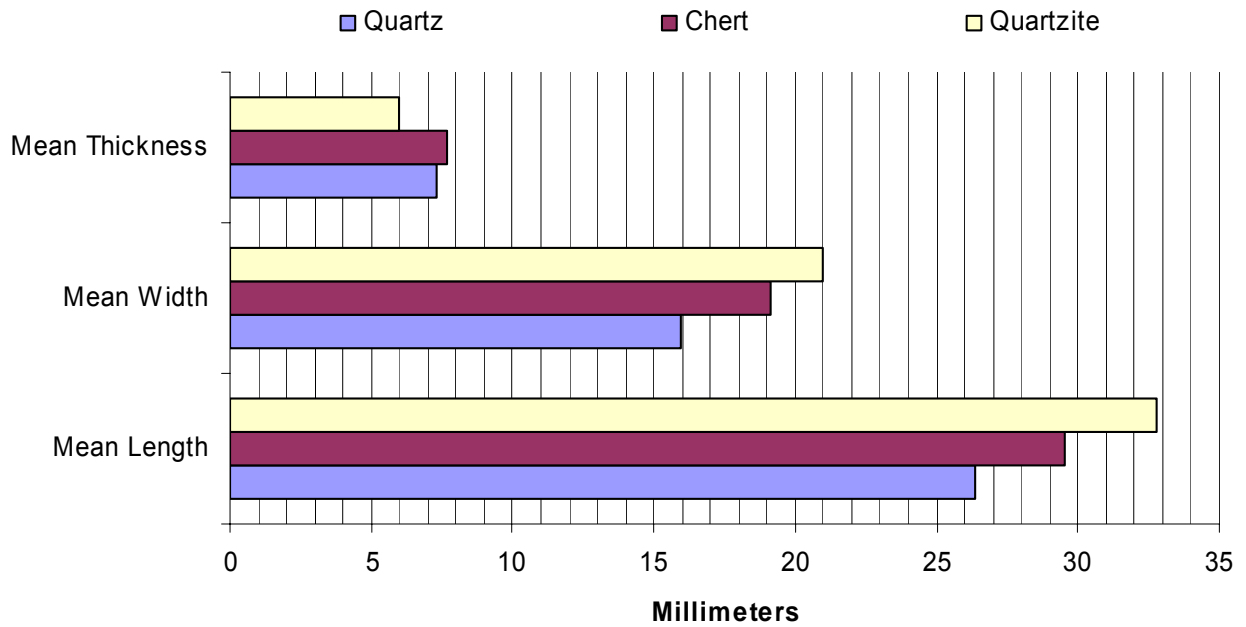

Figure 5.18. Name Chamber incomplete flake dimensions.

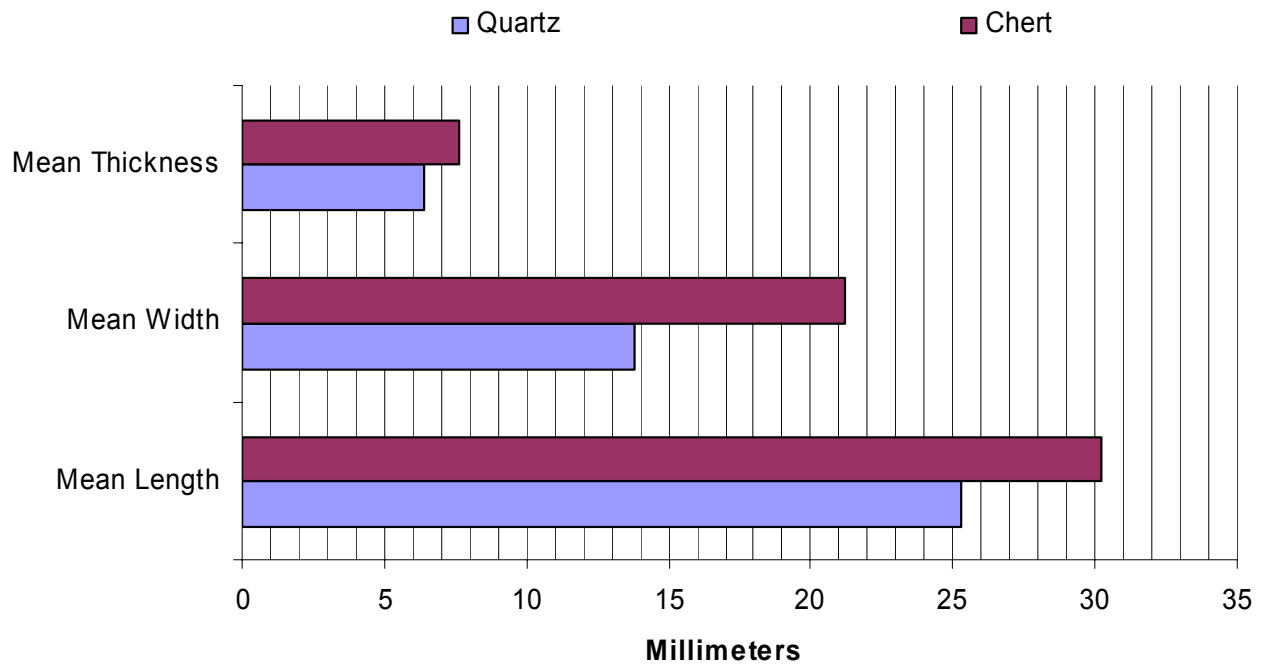

Figure 5.19. Name Chamber mean flake fragment dimensions.

From the data presented above it can be suggested that the three flake categories, complete flake, incomplete flake and flake fragment, derive from a single assemblage with similar flaking trends including raw material proportions, mean dimensions, mean number of flake scars, quantity of cortex cover and condition. From this data it can be suggested that all the flakes in the Name Chamber assemblage are of mutual origin both technologically and depositionally. The question at hand is whether the reduction of the core was continued after the production of these flakes, thus producing a higher proportion of flakes with scar numbers exceeding three scars per artefact, or was the core discarded after satisfactory numbers of flakes were produced for the job at hand? The latter pattern is expected in an expedient technology such as the Oldowan or Early Acheulean. Toth's (1985) flake classification method using dorsal cortex patterns and flake scars to identify reduction stage is difficult to apply due to the very small number of complete flakes with enough identifiable cortex (two). The data available from this small set of flakes shows that 89% have one or fewer flake scars illustrating this expedient raw material utilisation pattern common in the Oldowan and Early Acheulean. The data for all 76 Name Chamber

flakes is presented in Table 5.7 and Figures 5.20 – 5.23). The preferential use of quartz, which produces small, brittle flakes, demonstrates the opportunistic use of local materials for the production of large numbers of easily made flakes. The small number of quartzite flakes makes inferences regarding the efficiency of exploitation of this raw material misleading and inaccurate.

	Length	Width	Thickness	Flake Scars	Condition	% cortex cover	length max scar
Mode	21	16	7	0	F	0-25	19
Median	25	16	7	0	F	0-25	0
Mean	28	18	7	1	na	na	18

Table 5.7. Data for the total Name Chamber flakes.

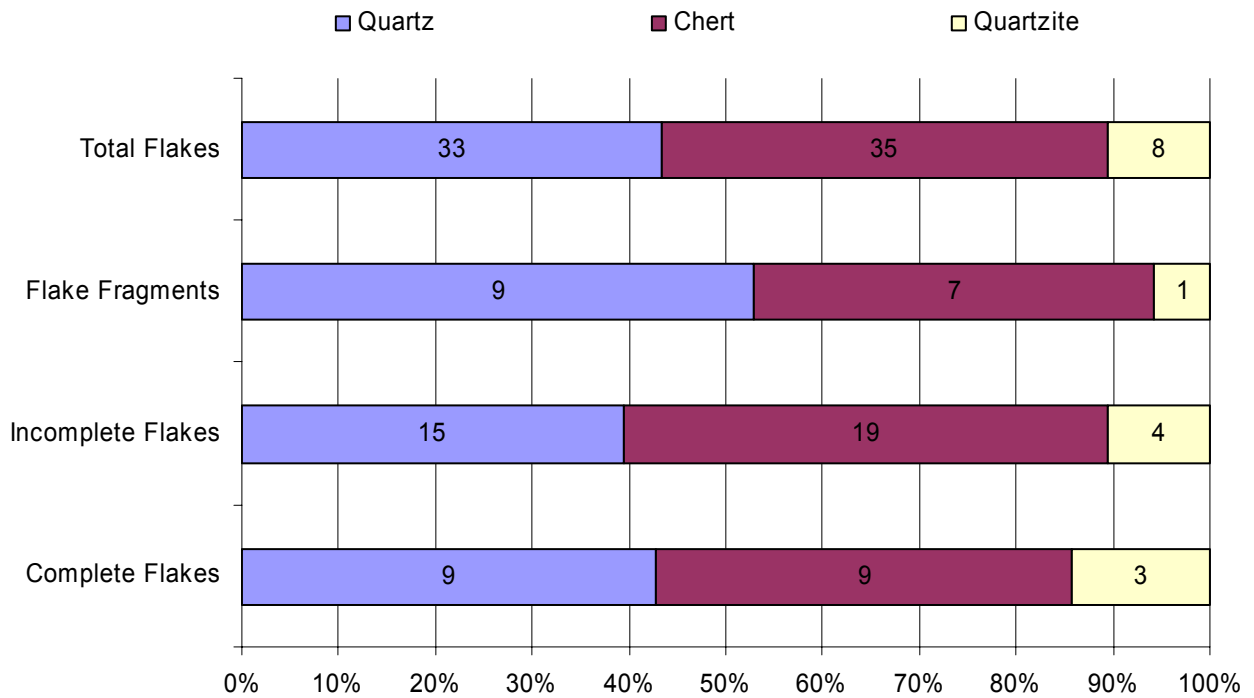

Figure 5.20. Name Chamber flakes by raw material.

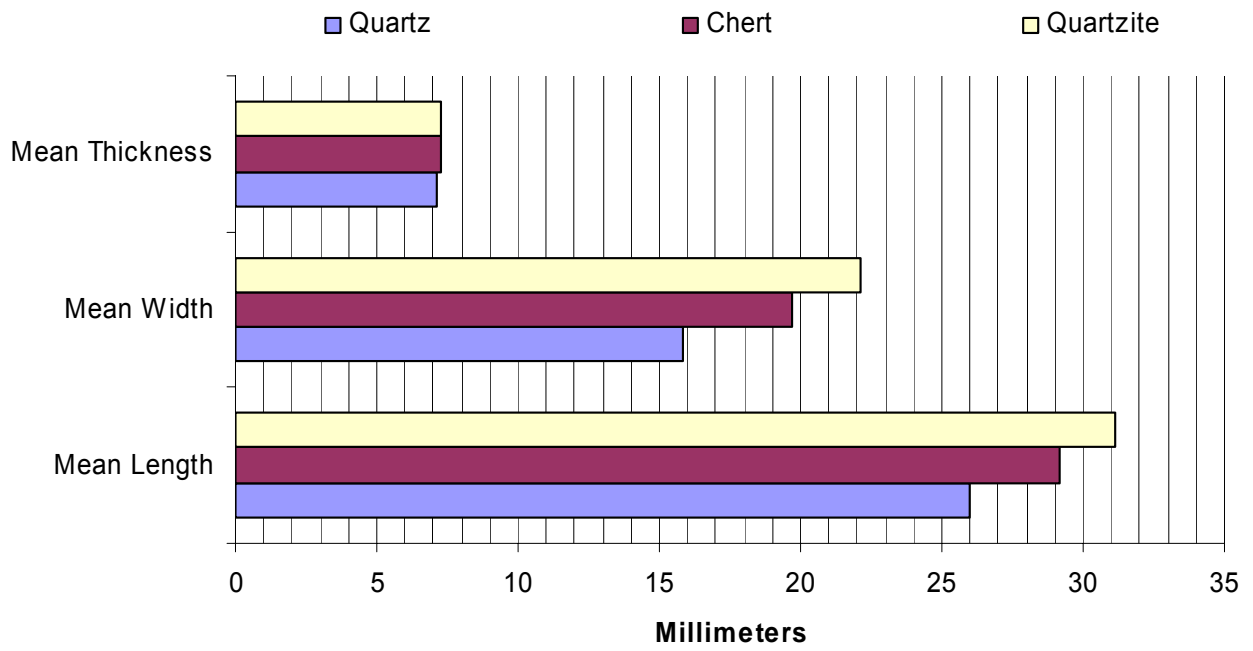

Figure 5.21. Name Chamber mean total flake dimensions.

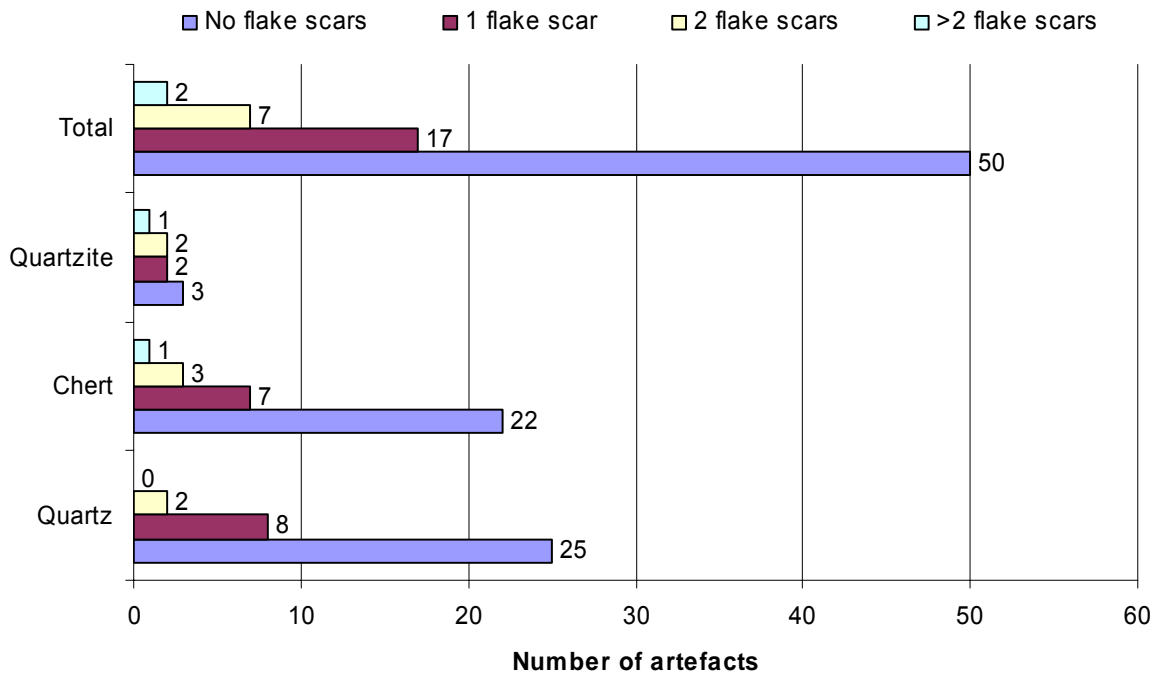

Figure 5.22. Name Chamber number of dorsal flake scars on flakes by raw material.

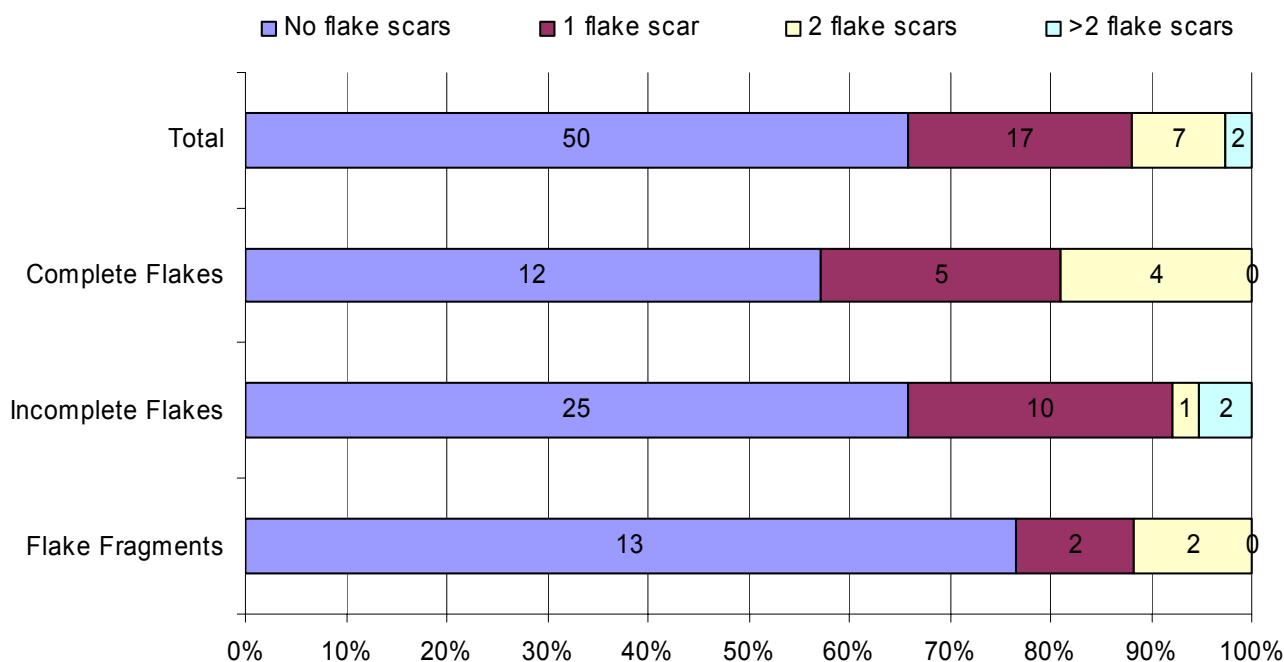

Figure 5.23. Name Chamber number of dorsal flake scars by flake type.

5.2.4. Small Flaking Debris

The small flaking debris category includes all pieces of artefactual origin measuring less than 19mm maximum length. This category represents 91.2% of the entire Name Chamber assemblage. The dominance of this category is essential to the understanding of the source of the Name Chamber archaeology. In the previous sections, concentrating on the ≥ 20 mm material, it is evident that the filtration processes within the feeding shaft are restricted to the artefacts > 50 mm maximum length and that no discernable filtration of raw material is taking place. It was suggested in Section 5.2.2 that the raw materials and artefact condition profile is equal to the equivalent profiles in the source assemblage. In experiments on vein quartz (Kuman and Field's 2008), an average of 87% of flaking debris < 20 mm was produced with 69% represented by 0 - 9mm and 18% by 10 - 19mm. In McNabb's experiments, undertaken with Kuman and Field, on local quartz he obtained figures of - 85% of < 20 mm flaking debris (Kuman and Field 2008). Schick's experiments with lava from Koobi Fora, Kenya produced between 60-75% debris < 20 mm with an average of 28% represented by 0 - 9mm and 41% for 10 - 19mm (Schick 1987b). The difference in raw material between Schick's and Kuman's

experiments combined with slightly different sampling procedures accounts for the difference in results (Kuman and Field 2008). In the Name Chamber assemblage, small flaking debris 0 - 9mm represents 54.1% of the assemblage (59% of the <20mm category), small flaking debris of 10 - 19mm represents 37% (41% of the <20mm category). One can see immediately that the <20mm category is over represented by 4% in the Name Chamber collection at 91% of the total assemblage. The 10 - 19mm artefacts are over represented by 19% and the 0 - 9mm is under represented by 14.9% when compared to Kuman and Field's (2008) experimental quartz assemblage. The presence of larger quantities of 10 – 19mm flaking debris is likely to be deceptive due to the missing 0 – 9mm portion of the assemblage, exaggerating the quantity of 10 – 19mm artefacts. Sourcing the <20mm material requires comparisons to be drawn with the other artefact-bearing deposits in contact with the feeding shaft. Figures 5.24 and 5.25 present the data for the small flaking debris. The uniformity in raw material proportions and artefact condition through the small flaking debris size classes illustrates the mutual origins of all the artefacts.

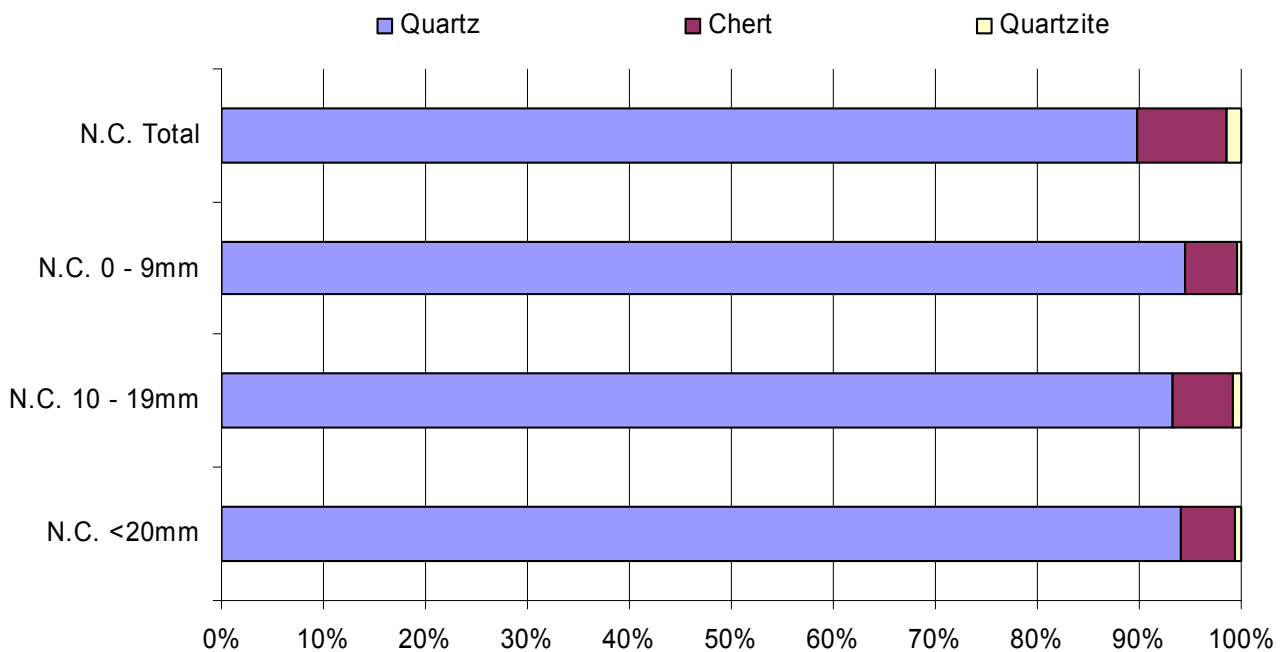

Figure 5.24. Name Chamber raw material proportions for <20mm artefacts.

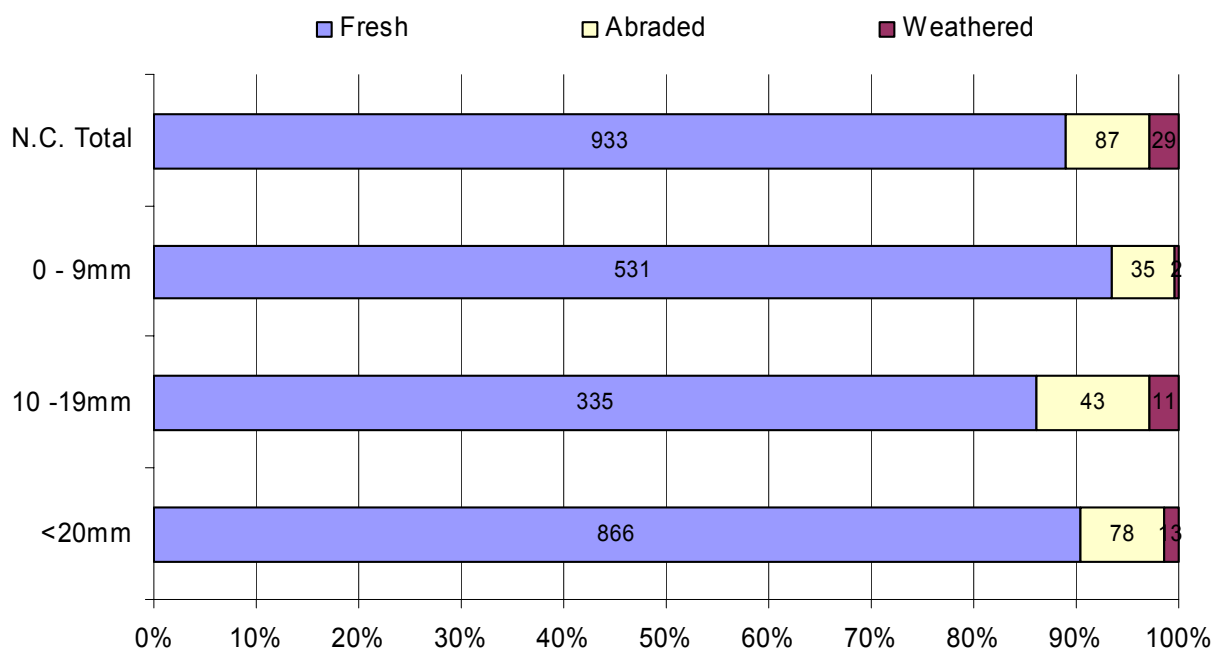

Figure 5.25. Name Chamber small flaking debris condition.

5.2.5 Name Chamber Archaeology Conclusions and Comparisons

Several conclusions can be drawn from the Name Chamber assemblage.

1. The producers of the artefacts which formed the Name Chamber assemblage utilised some raw materials from the river gravels, as seen from the pieces with identifiable cortex.
2. Quartz and chert are dominant. The low numbers of quartzite may illustrate off-site flaking of this material as in the Oldowan assemblage.
3. The flaking of these brittle raw materials produced a large proportion of <20mm material as indicated in experiments using similar raw materials.
4. Although the sample size is small there are indications of a limited reduction of cores as indicated from low flake scar numbers, which suggest an opportunistic, expedient industry.
5. The large proportion of incomplete flakes corresponds to the preferential use of more brittle raw materials.

6. Comparable raw material and artefact condition profiles between the Name Chamber and Oldowan through 91% of the assemblage indicate a common source for the whole assemblage.
7. The high proportion of the <10mm artefacts in the Name Chamber and their under-representation in the Oldowan assemblage may be related to the preferential loss of the smallest Oldowan artefacts down into the Name Chamber.

It is evident from the structure of the feeding shaft, the fine particle size of the sediments, and the size profile of the assemblage that material <50mm in size was allowed to pass through to the sampled part of the Western Talus. However, it also stands to reason that the excess in <20mm is not purely a feeding shaft filtration issue but also reflects the source assemblage which is dominated by this size category. The preferential movement of smaller artefacts is frequently experienced in surface deposits subjected to low-energy natural forces such as flowing water, capable of ‘winnowing’ a complete assemblage of its smaller elements. This process can also occur in cave deposits affected by dissolution (as opposed to collapse). It seems most likely that the smaller artefacts are being winnowed from the above Member 5, during decalcification and re-working of material within the breccia. Member 5 East is the only artefact-bearing deposit transected by the feeding shaft. We know from the geology of the Name Chamber and above deposits that the Member 5 deposit was formed before the feeding shaft was in operation. It then follows that at some point in the history of Member 5, the feeding shaft became operational and the smaller, <10mm, and a proportion of the <20mm artefacts were winnowed down and deposited into the Name Chamber, creating the large proportion of this size category of artefact. Currently only two artefact assemblages have been recovered from the Member 5 East deposit, the Oldowan (the deepest of the Member 5 assemblages), and the Early Acheulean which lies above the Oldowan and appears to be mixed by invasive solution pockets. As no diagnostic Acheulean artefacts occur below 22’ depth, the Oldowan breccia must have blocked the entrance to the feeding shaft by the time the Acheulean breccia was forming.

The only viable source assemblage for the Name Chamber collection is the Oldowan deposit of Member 5 East. Kuman has inferred that the under-representation of the <10m material in the Oldowan assemblage is due to the winnowing of this material

down into the Name Chamber (Kuman 2007), and the details of this theory and the Oldowan assemblage profile are given in Chapter 3. A comparison between the Name Chamber and the Oldowan must concentrated on the larger data sets from both assemblages, in order to allow more accurate statistical comparison. Data on artefact categories representing less than 1% of either assemblage prevents comparison. The patterns revealed in the comparisons between the two assemblages are in line with what would be expected if the Oldowan assemblage had been influenced by a winnowing process of the <10mm material. The raw material profiles are almost identical, as is to be expected if the artefacts have come from the same parent assemblage. The size profiles reveal a similar trend between assemblages, the contrast being large proportion of <10mm material within the Name Chamber (Figure 5.26 and 5.27). Of the ≥ 20 mm artefacts there are insufficient cores in the Name Chamber sample to hold a comparison, so only comparisons made with the proportions of flake types (incomplete, complete and flake fragments) were carried out. The proportions are very similar, 77.6% of flakes are incomplete for the Oldowan compared with 72% for the Name Chamber. It can be suggested from the corresponding flake type proportions that a similar understanding of flaking, knapping intention and ability produced both samples, given the utilisation of the same raw material (Figure 5.28).

In conclusion, it is most likely from the above data that the Name Chamber assemblage has been formed from the erosion and deposition of the Member 5 East Oldowan through the feeding shaft and into the current younger 'soft' infill. The characteristics of the Name Chamber collection fit exactly the expectations of an assemblage eroded from another secondary deposit. Those expectations include: a high proportion of small material - as this is the first component susceptible to erosion and movement; analogous raw material proportions, and similar flake type proportions in the absence of data from cores. It can be suggested from the above data that during the deposition or re-working of Member 5 Oldowan a proportion of the assemblage was winnowed out and deposited via the feeding shaft into the Name Chamber. This erosion of the calcified deposits transected by the feeding shaft need not have been a single event, as it would be facilitated by climatic oscillations governing the movement of fresh water through the shaft. The collapse of dolomitic blocks within the feeding shaft blocked artefacts >50mm from being deposited into the Western Talus. The sampling of the Eastern Talus, which is influenced by a lesser degree of filtration within the feeding shaft,

may yield a larger proportion of larger artefacts and fauna, and it may supply data from cores that will corroborate the above inference.

Table 5.8 shows the combined data from the Oldowan and Name Chamber collections. These combined figures provide a more complete assemblage which can be compared with the experimental assemblages created by Kuman and Field and McNabb. The <20mm category represents 84% of the total assemblage, within 2% of the experimental data produced in quartz and quartzite (Kuman and Field 2008). The <10mm is still under-represented but by a smaller quantity, undoubtedly due to the winnowing processes taking place in the soft deposit of Name Chamber Western Talus.

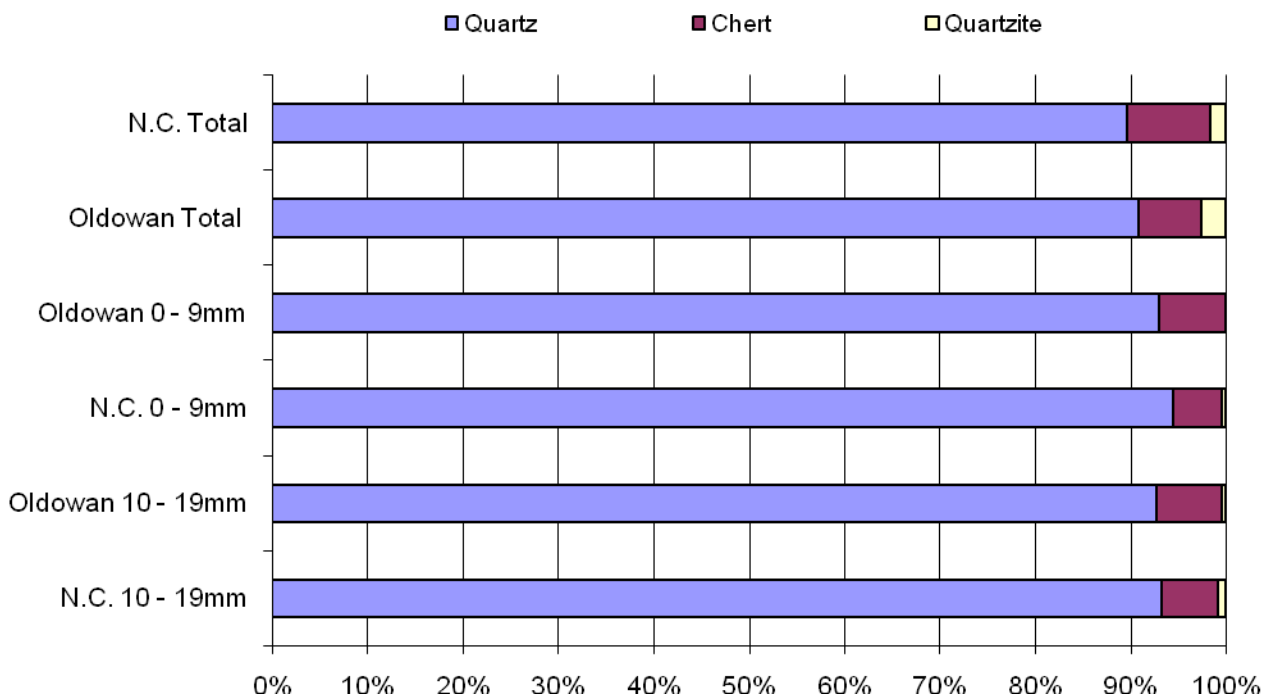

Figure 5.26. Oldowan vs. Name Chamber raw material proportions <20mm artefacts.

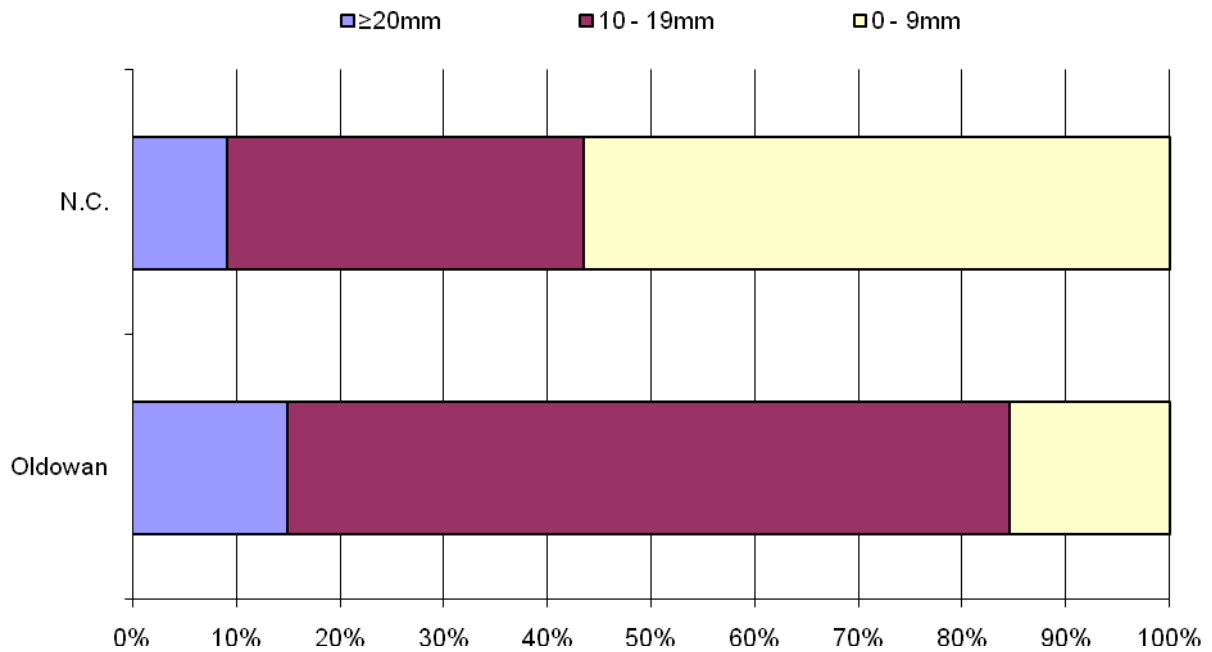

Figure 5.27. Oldowan vs. Name Chamber total assemblage by size category.

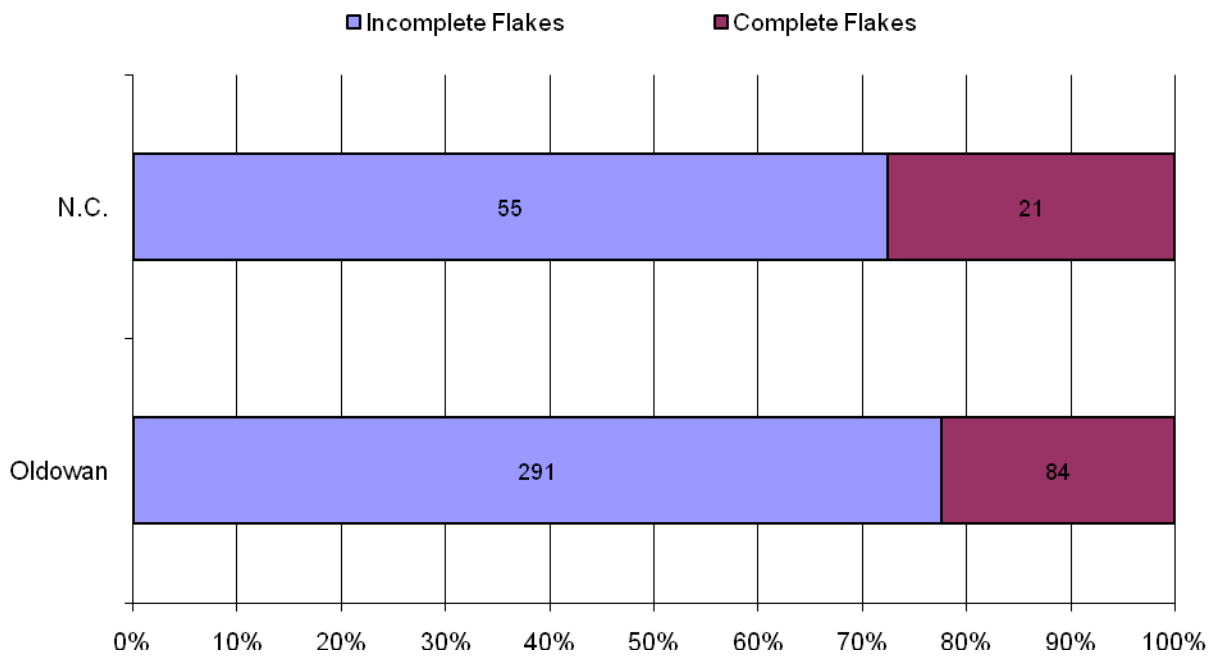

Figure 5.28. Oldowan vs. Name Chamber flake category proportions. In Kuman and Field's (2008) analysis of the Oldowan flake fragments are included in the incomplete flake category, for the purpose of this comparison the incomplete flakes and flake fragments have been combined for the Name Chamber assemblage.

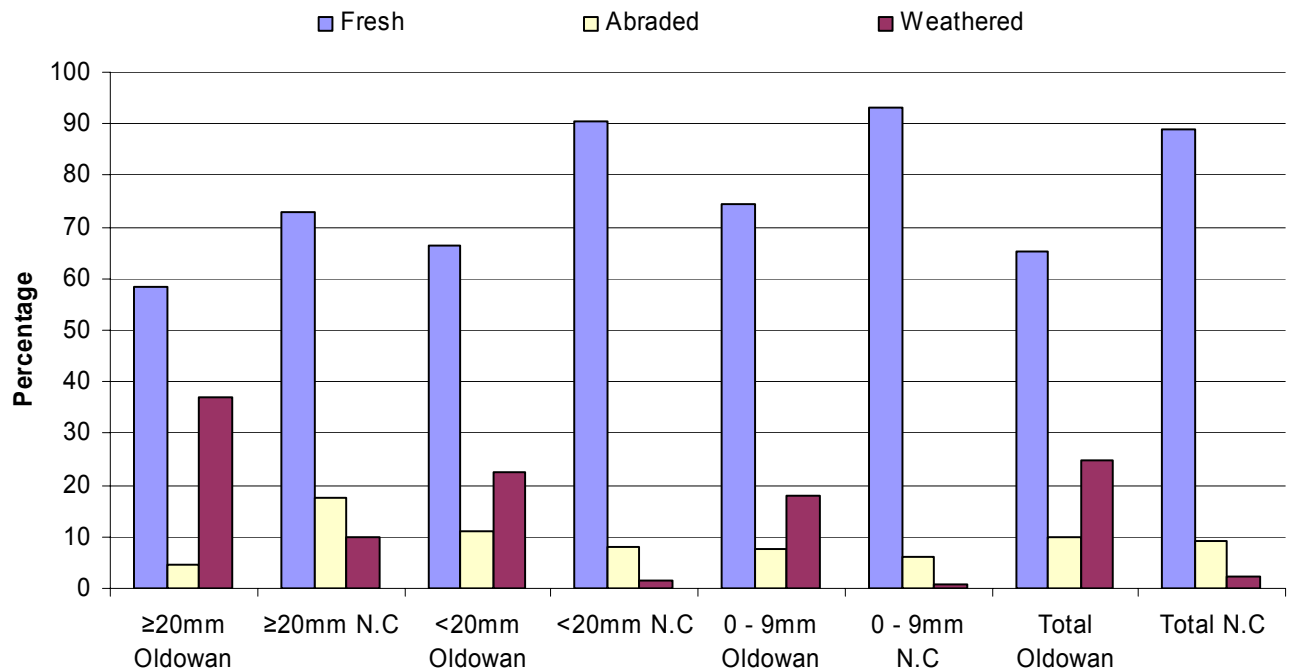

Figure 5.29. Oldowan vs. Name Chamber artefact condition through size category.

	Quartz	Chert	Quartzite	Other	Total	%
Small Flaking Debris <20mm	3644	256	14	0	3914	85.8
Complete flakes	66	16	23	0	105	2.3
Incomplete flakes	255	48	43	0	346	7.6
Chunks	121	2	11	0	134	2.9
Retouched pieces	5	1	1	0	7	0.2
Core tools	0	0	1	0	1	0.0
Cores	17	1	8	0	26	0.6
Core fragments	3	1	2	0	6	0.1
Manuports	2	1	8	1	12	0.3
Indeterminate	8	1	2	0	11	0.2
TOTAL	4121	327	113	1	4562	100.0
%	90.3	7.2	2.5	0.0	100.0	

Table 5.8. Sterkfontein Oldowan artefact type and raw material assemblage composition including the Name Chamber assemblage.

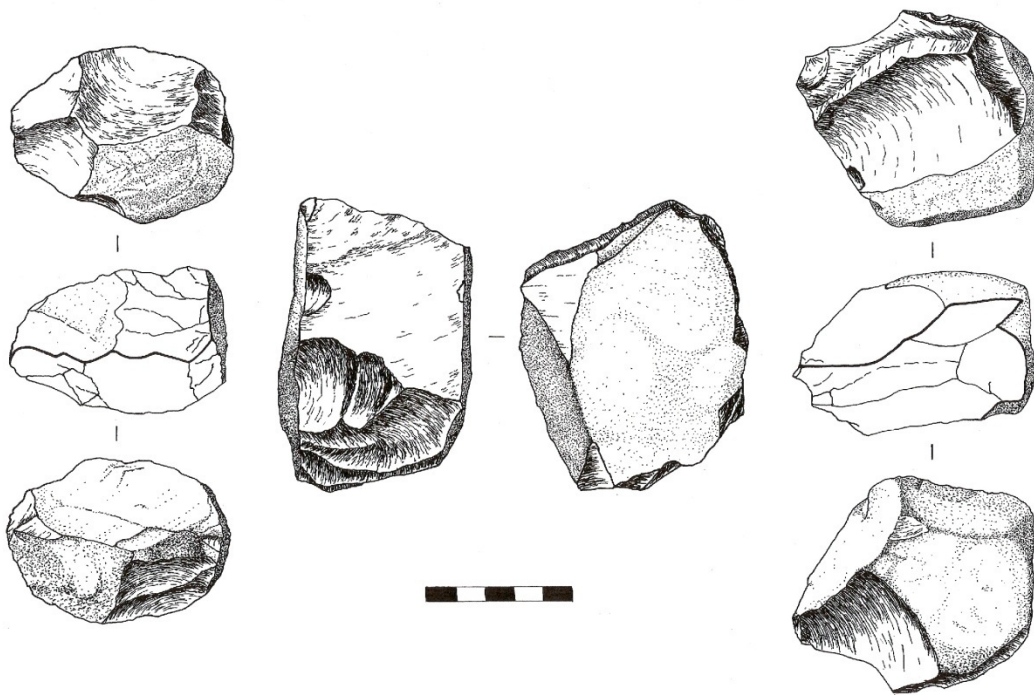

Figure 5.30. Artefacts recovered by Robinson from the Name Chamber.

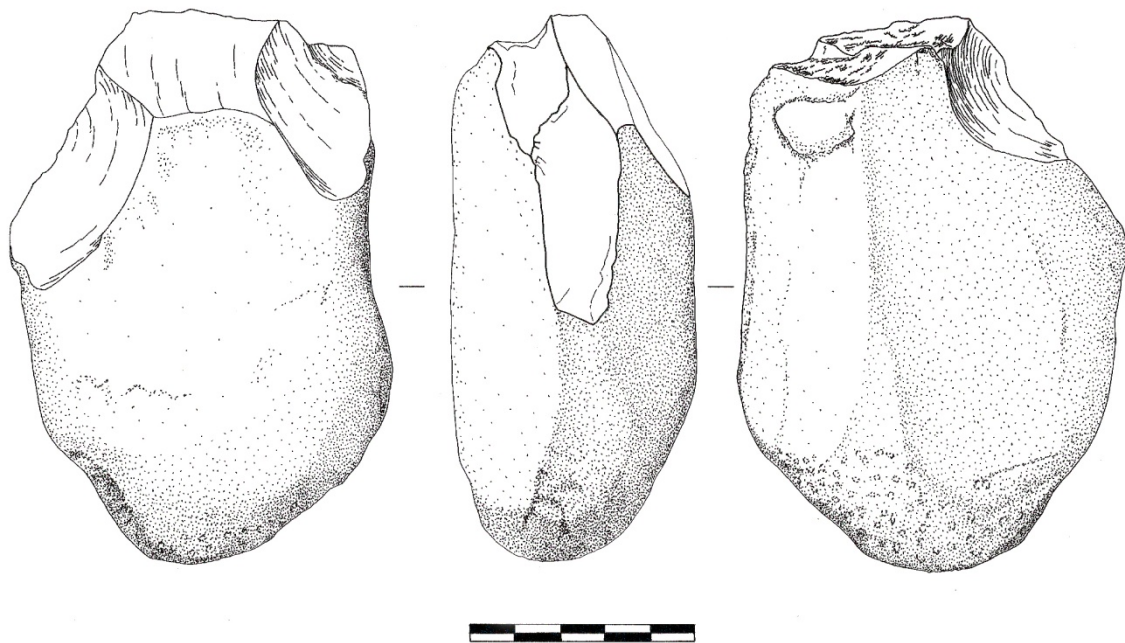

Figure 5.31. STK-NC 1.

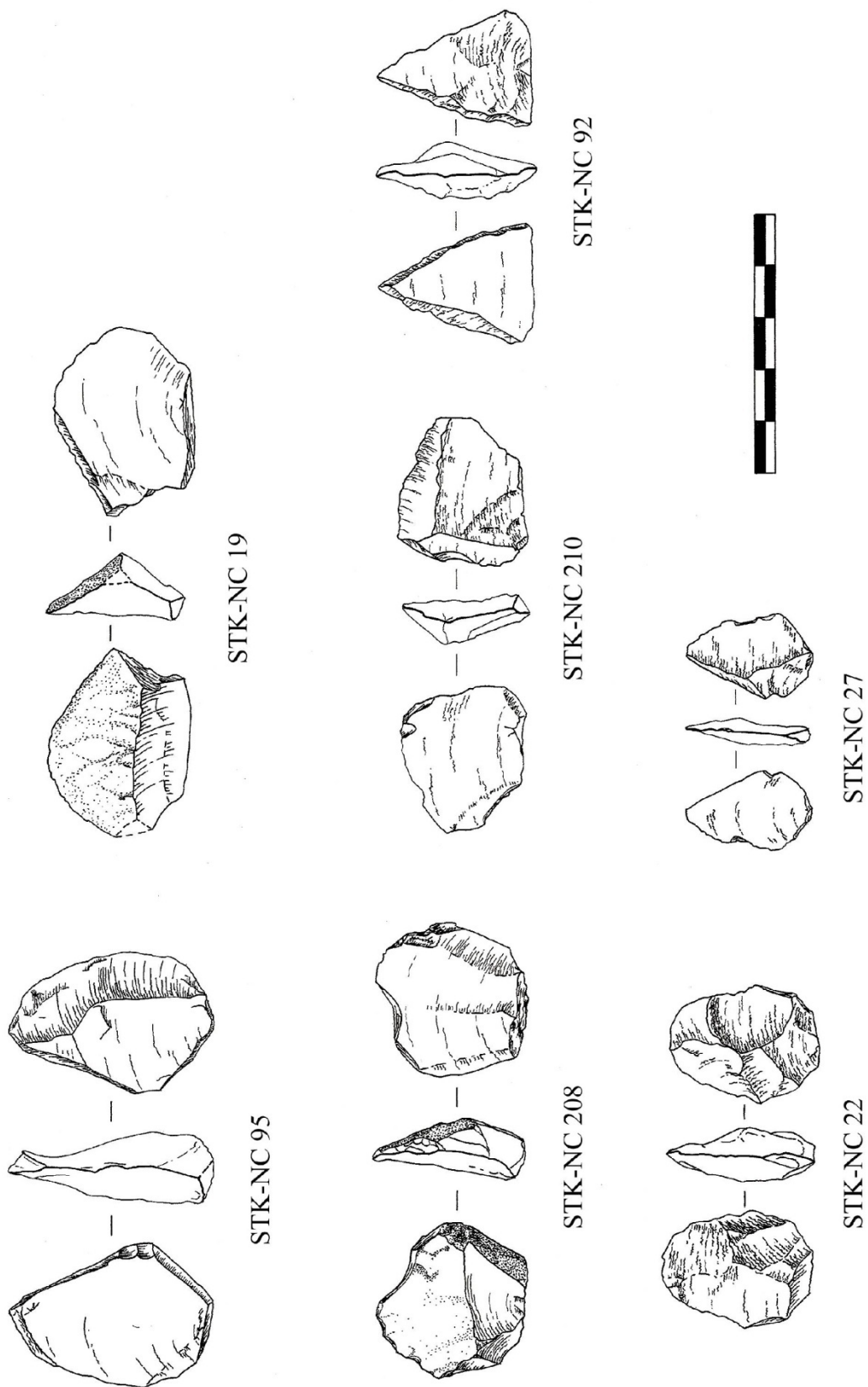

Figure 5.32. Name Chamber flakes.

Chapter 6. Conclusions and Discussion

6.1. Dump 21

From the data presented in Chapter 4, it can be concluded that the same raw material exploitation was carried out on the Dump 21 artefacts as the Early Acheulean assemblage from Member 5 West. Consequently the Dump 21 collection was originally part of the Early Acheulean of Member 5 but was subsequently removed to its most recent location at some point during the lime mining operations. The sourcing of good quality quartzites from the nearby river gravels paralleled with the dominant utilization of expedient reduction strategies which produced high proportions of polyhedral cores is exhibited by the hominids creating these assemblages. The generally high numbers of flake scars, high proportion of polyhedral cores, dominance of flake scars with feathered termination and the presence of a handaxe created on a large flake blank are indicative of a technology geared for the production of large quantities of flakes of varying size for immediate use but with a good understanding of fracture dynamics in different raw materials. The tool makers exhibit the ability to correct raw material flaws and produce flakes of greater size than is seen the Oldowan. The interesting element of the Dump 21 assemblage and the Early Acheulean is the presence of the radially flaked or discoidal cores. These cores show a marked change in reduction strategy towards a more organised flaking technique which flake scar data show generally produces larger numbers of flakes and greater uniformity in flake dimensions. This ability to produce consistently shaped flakes in a more efficient manner seems to have been practiced only sporadically as indicated by the low proportion of radially flake cores in the assemblage. It could be suggested that this reduction strategy was employed when access to the abundant raw materials at the nearby river was restricted, forcing the employment of more efficient flaking techniques. The combined Dump 21 and Early Acheulean assemblage is presented in Table 4.18. The absence of an equivalent proportion of manuports and smaller flaking debris can be interpreted as a sample size issue combined with a restricting contextual factor.

6.2. Name Chamber

Chapter 5 concentrated on the geology and the archaeology of the Name Chamber. The stratigraphy in the Name Chamber is now significantly clearer, and subsequent feeding shaft filtration processes influenced by the specifics of geology are supported by the archaeological evidence. The publication of micro-faunal and macro-faunal investigations should further test these conclusions. The oldest deposit, named the ‘ancient brecciated infill’, first filled the existing Sterkfontein system, including the Name Chamber prior to the opening of the cave to the surface. This deposit contains no fauna and so cannot be dated. The second deposit is the ‘old brecciated deposit’. Through future faunal and sedimentary sampling of the preserved Eastern Talus depositional sequence from the ‘old brecciated deposit,’ correlations can be drawn with other Sterkfontein members. If the ‘old brecciated deposit’ in the Name Chamber is contemporaneous with the current Member 2 deposit, as is suggested by Clarke and Bruxelles (personal communication), then early fossils may be preserved at the centre or base of the Name Chamber talus where the remnants of the second Name Chamber deposit may lie buried. Both the later deposits (the old brecciated deposit and the younger ‘soft’ deposit) accumulated through the deposition of material into the Name Chamber from the feeding shaft. The switches in the destination of sediment and the extent of active filtration facilitated by the feeding shaft were influenced by the collapse of internal blocks of dolomite within the feeding shaft walls. These changes between deposition into the Eastern Talus or Western Talus have been sporadic as is illustrated by the interactions between the Western and Eastern Talus of the current younger ‘soft’ deposit. When the Eastern Talus received material it had undergone less filtration as is indicated by the generally stonier matrix and larger maximum dimensions of sediment from this side of the chamber. The Far Western Talus and Western Talus are more heavily influenced by the filtration process due to a more congested internal structure on the western side of the feeding shaft. Finer matrix and smaller stones with maximum dimensions limited to <50mm are characteristic of the western side of the Name Chamber talus deposit. The sediment deposited into the Name Chamber can be sourced from the Sterkfontein deposits in contact with the feeding shaft which transects Member 5 East and possibly a small portion of Member 4.

The Western Talus is currently the only deposit to be sampled and analysed for micro-fauna, macro-fauna and archaeology. Archaeologically, the assemblage excavated from the Name Chamber is closely comparable to the Member 5 East Oldowan. Raw material and flake type proportions illustrate that the two collections originate from the same parent assemblage. Both collections (M5E Oldowan and Name Chamber) and the combined parent assemblage can be described as an expedient technology predominantly utilising the local quartz from the river gravels and landscape in order to produce large numbers of small, mostly incomplete but razor-sharp flakes. The intention of the knappers was to produce large numbers of flakes quickly. The technology displayed is typical of knapping behaviour during the Oldowan and Early Acheulean. The large proportion of artefacts <20mm in size, and in particular, the high proportion of <10mm material in the Name Chamber assemblage are likely to correspond to the under-representation of the <20mm and in particular the <10mm material from the Member 5 East Oldowan. The geology of the feeding shaft indicates that sediment deposited into the Western Talus is only susceptible to the filtration of pieces >50mm in size. Therefore, the accumulation of large quantities of <20mm material is not due to the filtration process but due to the winnowing of smaller material from the original assemblage in the Member 5 East Oldowan Infill. The less significant filtration processes active in the Eastern Talus may have allowed larger materials to be deposited in this un-sampled side of the Name Chamber deposit. A further degree of winnowing is to be expected in the Name Chamber due to the soft nature of the deposit and the accumulation and erosion process taking place. If the feeding shaft were to be re-opened in the future, one would expect to see a cumulatively increasing quantity of material washed or winnowing from this shaft deposit to a lower level. This lower level has already received material from the first 'ancient brecciated infill', the second 'old brecciated infill' and the current younger 'soft' infill. Sampling of the Jacovec Cavern, which lies directly below the southern end of the Name Chamber, may reveal the source of this eroded material and yield further contributions to the Sterkfontein Oldowan.

The examination of the Name Chamber stratigraphy and geology combined with the archeological sampling of the younger 'soft' deposit has clarified the processes involved in the deposition of archaeological material from the above Member 5 Oldowan deposit. The excavation of an assemblage with a 91% small flaking debris component and the successful correlation through analysis to its parent assemblage has significantly

improved the completeness of the Sterkfontein Oldowan collection. The sourcing of a part of the missing small flaking debris from the Member 5 Oldowan has confirmed theories regarding the knapping practices of the Oldowan tool maker, namely that flaking was carried out mainly on quartz cobbles selected primarily from the river gravels nearby and flaked within the small catchment area of the cave shaft opening. The hominids used the shelter provided by the trees that surround these cave entrances. Further excavations in the un-sampled Name Chamber deposits may yield further quantities of the missing flaking debris and, due to the varying levels of filtration at work in the feeding shaft, yield a greater proportion of the larger (>50mm) diagnostic artefacts.

The expansion of the Sterkfontein Early Acheulean assemblage (even by 35 artefacts) provides corroborating evidence in the search for consistent patterns within technological strategies. The Dump 21 collection was compared to the Sterkfontein Early Acheulean of Member 5 West and found to be analogous in terms of technological and typological trends. The Early Acheulean at Sterkfontein is characterized by an opportunistic and typically non-exhaustive use of selected quartzite cobbles from the nearby river gravels.

The analysis and expansion of Plio-Pleistocene stone tool assemblages is of key importance in establishing consistent patterns of raw material use, land-use, and behaviour for the early tool-making hominids of the Sterkfontein and Cradle of Humankind sites. This research has expanded the Sterkfontein Oldowan and Early Acheulean assemblages, allowing greater confidence in current theories of hominid tool and landscape utilisation.

Bibliography

- Ahler, A.S. 1989. Mass analysis of flaking debris: studying the forest rather than the trees. In: Henry, D.O. & Odell, G.H. (eds.) *Alternative Approaches to Lithic Analysis. Archaeological Papers of the American Anthropological Association* 1: 85-118.
- Andrefsky, Jr.W. 1986. A consideration of Blade and Flake curvature. *Lithic Technology* 15: 48-54.
- Andrefsky, Jr.W. 2001. Emerging directions in debitage analysis. In: Andrefsky, Jr.W. (ed.) *Lithic Debitage: Context, Form, Meaning*: 1-14. University of Utah Press, Salt Lake City.
- Andrefsky, Jr.W. 2006. The application and misapplication of mass analysis in lithic debitage studies. *Journal of Archaeological Science* 20: 1-11.
- Austin, R.J. 1999. Technological Characterization of lithic waste-flake assemblages: multivariate analysis of experimental and archaeological data. *Lithic Technology* 24: 53-68.
- Bamforth, D.B. 1991. Technological organization and hunter-gatherer land use: a California example. *American Antiquity* 56: 216-234.
- Berger, L.R., Lacruz, R. & de Ruiter, D.J. 2002. Brief Communication: Revised Age Estimates of *Australopithecus*- Bearing Deposits at Sterkfontein, South Africa. *American Journal of Physical Anthropology* 119: 192-197.
- Bradbury, A.P. & Carr, P.J. 1995. Flake Typologies and Alternative Approaches: An Experimental Assessment. *Lithic Technology* 20: 100-115.
- Brain, C.K. 1958. The Transvaal ape-man-bearing cave deposits. *Transvaal Museum Memoir* 11: 1-131.
- Brain, C.K. 1993. Swatkrans, A Cave's Chronicle of Early Man. *Tranvaal Museum Monograph*, no. 8. Pretoria.
- Brooke, S. 2003. Blades, end scraper reduction and hunter-gatherer mobility. *American Antiquity* 68: 141-156.
- Broom, R. 1936. A new fossil anthropoid skull from South Africa. *Nature* 138: 486-488.
- Broom, R. 1950. *Finding the Missing Link*. Watts & Co. London
- Burkitt, M.C. 1928. *South Africa's Past in Stone and Paint*. Cambridge.

- Carr, P.J. & Bradbury, A.P. 2001. Flake Debris Analysis, Levels of Production, and the Organisation of Technology. In: Andrefsky, Jr.W. (ed.) *Lithic Debitage: Context, Form and Meaning*: 126-146. University of Utah Press, Salt Lake City.
- Clark, J.D. 1959. *The Prehistory of Southern Africa*. London: Penguin Books.
- Clark, J.D. 1970. *The Prehistory of Africa*. Thames and Huson.
- Clarke, R.J. 1988. Habiline handaxes and paranthropine pedigree. *World Archaeology* 20: 1–12.
- Clarke, R.J. 1994. On some new interpretations of Sterkfontein stratigraphy. *South African Journal of Science* 90: 211-214.
- Clarke, R.J. 1999. Discovery of complete arm and hand of the 3.3 million-year-old *Australopithecus* skeleton from Sterkfontein. *South African Journal of Science* 95: 477–480.
- Clarke, R.J. 2002. On the unrealistic ‘Revised age estimates’ for Sterkfontein. *South African Journal of Science* 98: 415-419.
- Clarke, R.J. 2006. A deeper understanding of the stratigraphy of Sterkfontein fossil hominid site. *Transactions of the Royal Society of South Africa* 61 (2): 111-120.
- Clarke, R.J. & Tobias, P.V. 1995. Sterkfontein Member 2 foot-bones of the oldest South African hominid. *Science* 269: 521–524.
- Cooke, H.B.S. 1938. The Sterkfontein bone breccia: a geological note. *South African Journal of Science* 35: 204–208.
- Cotterell, B. & Kamminga, J. 1979. The mechanics of flaking. In: Hayden, B. (ed.) *Lithic Usewear Analysis*: 79-112. New York Academic Press.
- Cotterell, B. & Kamminga, J. 1987. Finials on stone flakes. *Journal of Archaeological Science* 13: 451-461.
- Cotterell, B. & Kamminga, J. 1990. *Mechanics of pre-industrial technology*. Cambridge: Cambridge University Press.
- Crabtree, D.E. 1972. An Introduction to Flintworking. *Occasional Papers of the Idaho State Museum* 28. Pocatello.
- Delagnes, A. & Roche, H. 2005. Late Pliocene hominid knapping skills: The case of Lokalalei 2C, West Turkana, Kenya. *Journal of Human Evolution* 48: 435-472.

- Dibble, H.L. & Pelcin, A. 1995. The effect of hammer mass and velocity on flake mass. *Journal of Archaeological Science* 22: 429-439.
- Field, A.S. 1999. *An analytical and comparative study of the Earlier Stone Age archaeology of the Sterkfontein Valley*. Msc. Dissertation. University of Witwatersrand.
- Fladmark, K.R. 1982. Microdebitage analysis: initial considerations. *Journal of Archaeological Science* 9: 205-220.
- Goodwin, A.J.H. 1926. South African Stone Implement Industries. *South African Journal of Science* 23: 784-788.
- Goodwin, A.J.H. & van Riet Lowe, C. 1929. The Stone Age cultures of South Africa. *Annals of the South African Museum* 27: 1-289.
- Hughes, A.R. & Tobias, P.V. 1977. A fossil skull probably of the genus *Homo* from Sterkfontein, Tansvaal. *Nature* 265: 310-312.
- Hull, K.L. 1987. Identification of cultural site formation processes through microdebitage analysis. *American Antiquity* 52: 772-783.
- Inizan, M.-L., Reduron-Ballinger, M., Roche, H. & Tixier, J. 1999. *Technology and Terminology of Knapped Stone*. Nanterre: CREP.
- Johnson, J.K. 2001. Some Reflections on Debitage Analysis. In: Andrefsky, Jr.W. (ed.) *Lithic Debitage: Context, Form and Meaning*: 15-21. University of Utah Press, Salt Lake City.
- Kibii, J. 2004. *Comparative taxonomic, taphonomic and palaeoenvironmental analysis of 4-2.3 million year old Australopithecine cave infills at Sterkfontein*. PhD Dissertation, University of Witwatersrand.
- Kroll, E.M. 1994. Behavioural implications of Plio-Pleistocene archaeological site structure. *Journal of Human Evolution* 27: 107-138.
- Kuijt, I., Prentiss, W.C. & Pokotylo, D.J. 1995. Bipolar reduction: an experimental study ofdebitage variability. *Lithic Technology* 20: 116-127.
- Kuman, K. 1994a. The archaeology of Sterkfontein: past and present. *Journal of Human Evolution* 27: 471-495.
- Kuman, K. 1994b. The archaeology of Sterkfontein: preliminary findings on site formation and cultural change. *South African journal of Science* 90: 215-219.

- Kuman, K. 1996. The Oldowan industry from Sterkfontein: raw materials and core forms. In: Pwiti, G. & Soper, R. (eds.) *Aspects of African Archaeology: Papers from the 10th Congress of the Panafrican Association for Prehistory and Related Studies*: 139-146. Harare: University of Zimbabwe Press.
- Kuman, K. 1997. Recent findings on the archaeology of Sterkfontein. *Four million years of hominid evolution, proceedings of a congress in honour of Dr. Mary Leakey*, Arusha, Tanzania 1993. *Kaupia* 6, Germany.
- Kuman, K. 1998. The earliest South African industries. In: Petraglia, M.D. & Korisettar, R. (eds.) *Early Human Behaviour in Global Context. The Rise and Diversity of the Lower Palaeolithic Record*: 108-132. Routledge: London and New York.
- Kuman, K. 2003. Site formation in the early South African Stone Age sites and its influence on the archaeological record. *South African Journal of Science* 99: 251-254.
- Kuman, K. 2007. The Earlier Stone Age in South Africa: site context and the influence of cave studies. In: Pickering, T.R., Schick, K. & Toth, N. (eds.) *Breathing Life into Fossils: Taphonomic Studies in Honor of C.K. (Bob) Brain*: 181-198. Bloomington (Indiana): Stone Age Institute Press.
- Kuman, K. & Clark, R.J. 1996. Artefact industries and hominid associations from Member 5, Sterkfontein. *Paper presented at the 13th Biennial Conference, Society of Africanist archaeologists, Poznan*.
- Kuman, K. & Clark, R.J. 2000. Stratigraphy, Artefact Industries and Hominid associations, Member 5. *Journal of Human Evolution* 38: 827-847.
- Kuman, K. & Field, A.S. 2008 (in press). The Oldowan Industry from Sterkfontein Caves, South Africa. In: Schick, K. & Toth, N. (eds.) *The Cutting Edge: Approaches to the Earliest Stone Age*. Bloomington (Indiana). Stone Age Institute Press.
- Kuman, K., Field, A.S. & McNabb, J. 2005. La Préhistoire ancienne de l'Afrique méridionale: contribution des sites à hominidés d'Afrique du Sud. In: Sahnouni, M. (ed.) *Les Cultures Paléolithiques en Afrique*: 53-82. Paris: Artcom/Errance.
- Kuman, K. & Gibbon, R.J. (in press) The early Acheulean of South Africa: Sterkfontein valley and the Vaal River basin.
- Leakey, L.S.B. 1936. *Stone age Africa*. Oxford University Press London: Humphrey Milford.
- Leakey, M.D. 1970. Stone artefacts from Swartkrans. *Nature* 225: 1222.

- Leakey, M.D. 1971. *Olduvai Gorge, Vol. 3*. Cambridge University Press, Cambridge.
- Leroi-Gourhan, A. 1943. *Evolution et Techniques I: L'homme et la Matière*. Paris: Albin Michel.
- Luyt, C.J. 2001. *Revisiting the palaeoenvironments of the South African hominid-bearing Plio-Pleistocene sites: new isotopic evidence from Sterkfontein*. Msc. Dissertation, University of Cape Town.
- Luyt, C.J. & Lee-Thorp, J.A. 2003. Carbon isotope ratios of Sterkfontein fossils indicate a marked shift to open environments c. 1.7 Myr ago. *South African Journal of Science* 99: 271-273.
- Magne, M.P. 1985. *Lithics and Livelihood: Stone Tool Technologies of Central and Southern Interior British Columbia*. Mercury Series Archaeological Survey of Canada Paper No. 133. National Museum of Man, Ottawa.
- Mason, R.J. 1962. *Prehistory of the Transvaal*. Johannesburg: Witwatersrand University Press.
- Mourre, V. 1996. Les Industries en quartz au palaeolithique: terminologie, methodologie et technologie. *Palaeo* 8: 205-223.
- Nadel, D. 1999. Indoor/outdoor flint knapping and minute debitage remains: the evidence from the Ohalo II submerged camp (19.5 KY, Jordan Valley). *Lithic Technology* 26: 118-137.
- Newcomer, M.H. & Sieveking, de G.G. 1980. Experimental Flake Scatter-Patterns: A New Interpretive Technique. *Journal of Field Archaeology* 7: 345-352.
- Olausson, D. 1997. Different strokes for different folks, possible reasons for variation in quality of knapping. *Lithic Technology* 23: 90-115.
- Partridge, T.C. 1978. Re-appraisal of lithostratigraphy of Sterkfontein hominid site. *Nature* 275: 282-287.
- Partridge, T.C. & Watt, I.B. 1991. The stratigraphy of the Sterkfontein hominid deposit and its relationship to the underground cave system. *Palaeontology Africa* 28: 35-40.
- Partridge, T.C., Granger, D.E., Caffee, M.W. & Clarke, R.J. 2003. Lower Pliocene hominid remains from Sterkfontein. *Science* 300: 607-612.
- Partridge, T.C. 2005. Dating of the Sterkfontein hominids: progress and possibilities. *Transactions of the Royal Society of South Africa* 60 (2): 107-109.

- Patterson, L.W. 1990. Characteristics of bifacial-reduction flake-size distribution. *American Antiquity* 55: 550-558.
- Péringuey, L. 1911. The Stone ages of South Africa. *Annals of the South African Museum* 8.
- Petraglia, M.D. & Potts, R. 1994. Water Flow and the Formation of Early Pleistocene Artifact Sites in Olduvai Gorge, Tanzania. *Journal of Anthropological Archaeology* 13: 228-254.
- Pickering, T.R. 1999. *Taphonomic interpretations of the Sterkfontein early hominid site (Gauteng, South Africa) reconsidered in light of recent evidence*. Ph.D. Dissertation, University of Wisconsin-Madison.
- Plummer, T. 2005. Discord after discard: reconstructing aspects of Oldowan hominin behaviour. In: Stahl, A.B. (ed.) *African Archaeology: A Critical Introduction*: 55-92. Oxford: Blackwell Publishing.
- Potts, R. 1991. Why the Oldowan? Plio-Pleistocene toolmaking and the transport of resources. *Journal of Human Evolution* 27: 7-24.
- Prentiss, W.C. 1998. The Reliability and Validity of a Lithic Debitage Typology: Implications for Archaeological Interpretation. *American Antiquity* 63: 635-650.
- Reed, K.E. 1997. Early hominid evolution and ecological change through the African Plio-Pleistocene. *Journal of Human Evolution* 32: 289-322.
- Reynolds, S.C., Clarke, R.J. & Kuman, K. 2007. The view from the Lincoln Cave: mid to late Pleistocene fossil deposits from Sterkfontein hominid site, South Africa. *Journal of Human Evolution* 53 (3): 260-271.
- van Riet Lowe, C. 1937. The archaeology of the Vaal River basin. In: Sohngé, P.B., Visser, D.J.L. & van Riet Lowe, C. (eds.) *The Geology and Archaeology of the Vaal River Basin*. Geological Survey (South Africa), Memoir 35.
- van Riet Lowe, C. 1938. A projected survey of the prehistory of South Africa. *Union of South Africa. Bureau of Archaeology*. Archaeological Series 2.
- Robinson, J.T. 1957. Occurrence of stone artifacts with *Australopithecus* at Sterkfontein (Parts 1 and 2). *Nature* 180: 521-524.
- Robinson, J.T. 1962. Sterkfontein stratigraphy and the significance of the Extension Site. *South African Archaeological Bulletin* 17: 87-107.

- Schick, K.D. 1987a. Modelling the formation of Early Stone Age artifact concentrations. *Journal of Human Evolution* 16: 789-807.
- Schick, K.D. 1987b. Experimentally-derived criteria for assessing hydrologic disturbance of archaeological sites. In: Nash, D.T. & Petraglia, M.D. (eds.) *Natural formation processes and the archaeological record*: 86-107. *British Archaeological Reports International Series* 319. Oxford.
- Schick, K.D. 1997. Experimental studies of site-formation processes. In: Isaac, G. & B. (eds.) *Koobi Fora Research Project 5. Plio-Pleistocene Archaeology*: 244-256. Oxford: Clarendon Press.
- Schick, K. & Toth, N. 2006. An overview of the Oldowan Industrial Complex: the sites and the nature of their evidence. In: Schick, K. & Toth, N. (eds.) *The Oldowan: Case Studies into the Earliest Stone Age*. Stone Age Institute Publication Series 1. Bloomington, Indiana: Stone Age Institute Press.
- Semaw, S. 2000. The world's oldest stone artifacts from Gona, Ethiopia: their implications for understanding stone technology and patterns of human evolution between 2.6-1.5 million years ago. *Journal of Archaeological Science* 27: 1197-1214.
- Semaw, S., Rogers, M.J., Quade, J., Renne, P.R., Butler, R.F., Stout, D., Dominguez-Rodrigo, M., Hart, W., Pickering, T. & Simpson, S.W. 2003. 2.6-Million-year-old stone tools and associated bones from OGS-6 and OGS-7, Gona, Afar, (Ethiopia). *Journal of Human Evolution* 45 (2): 169-175.
- Shelley, P.H. 1990. Variation in lithic assemblages: an experiment. *Journal of Field Archaeology* 17: 187-193.
- Shott, M.J. 1994. Size and Form in the analysis of Flake Debris: Review and recent Approaches. *Journal of Archaeological Method and Theory* 1(1): 69-110.
- Shott, M.J. 2000a. The quantification problem in stone-tool assemblages. *American Antiquity* 65: 725-738.
- Shott, M.J. 2000b. Flake Size from Platform Attributes: Predictive and Empirical Approaches. *Journal of Archaeological Science* 27: 877-894.
- Speth, J.D. 1972. Mechanical basis of percussion flaking. *American Antiquity* 37: 34-60
- Speth, J.D. 1974. Experimental investigations into hard-hammer percussion flaking. *Tebiwa* 17: 7-36.
- Speth, J.D. 1975. Miscellaneous studies in hard-hammer percussion flaking: the effects of oblique impact. *American Antiquity* 40: 203-207.

- Speth, J.D. 1981. The role of platform angle and core size in hard-hammer percussion flaking. *Lithic Technology* 10: 16-21.
- Stahle, D.W. & Dunn, J.E. 1982. An analysis and application of the size distribution of waste flakes from the manufacture of bifacial tools. *World Archaeology* 14: 84-97.
- Stiles, D. 1991. Early hominid behaviour and culture tradition: raw material studies in Bed II, Olduvai Gorge. *The African Archaeological Review* 9: 1-19.
- Stiles, D. & Partridge, T.C. 1979. Results of recent archaeological and palaeoenvironmental studies at the Sterkfontein Extension Site. *South African Journal of Science* 75: 346-352.
- Stout, D., Quade, J., Semaw, S., Rogers, M. & Levin, N. 2005. Raw material selectivity of the earliest stone toolmakers at Gona, Afar, Ethiopia. *Journal of Human Evolution* 48 (4): 365-380.
- Sullivan, III, A.P. & Rozen, K.C. 1985. Debitage Analysis and Archaeological Interpretation. *American Antiquity* 50 (4): 755-779.
- Tavoso, A. 1972. Les industries de la moyenne terrasse du Tarn à Técou (Tarn). *Bulletin du Musée d'Anthropologie préhistorique de Monaco* 18: 113-144.
- Tavoso, A. 1976. Les civilisations du Paléolithique moyen dans le bassin du Tarn. In: Lumley, H. (ed.) *La Préhistoire française*: 1041-1047. CNRS.
- Tobias, P.V. & Hughes, A.R. 1969. The New Witwatersrand University Excavation at Sterkfontein: Progress Report, Some Problems and First Results. *South African Archaeological Bulletin* 24: 158-169.
- Tobias, P.V., Clarke, R.J. & White, H. 1993. 27th Annual Report of the Palaeo-Anthropology Research Unit, University of the Witwatersrand.
- de la Torre, I, Mora, R, Domingo-Rodrigo, M, de Luque, L. & Alcalá, L. 2003. The Oldowan industry of Peninj and its bearing on the reconstruction of the technological skills of Lower Pleistocene hominids. *Journal of Human Evolution* 44: 203-224.
- de la Torre, I. 2004. Omo Revisited. Evaluating the Technological Skills of Pliocene Hominids. *Current Anthropology* 45 (4): 439-465.
- Toth, N. 1982. *The stone technologies of early hominids at Koobi Fora, Kenya: an experimental approach*. PhD Dissertation, University of California, Berkeley.

- Toth, N. 1985. The Oldowan reassessed: a close look at early stone tool artefacts. *Journal of Archaeological Science* 12: 101-120.
- Toth, N. & Schick, K.D. 1986. The first million years: the archaeology of protohuman culture. In: Schiffer, M.B. (ed.) *Advances in archaeological method and theory*. Vol 9. Orlando, Florida: Academic Press, Inc.
- Villa, P. 1983. *Terra Amata and the Middle Pleistocene Archaeological Record of Southern France*. Berkeley and Los Angeles: University of California Press.
- Vrba, E.S. 1975. Some evidence of chronology and paleoecology of Sterkfontein, Swartkrans and Kromdraai from the fossil Bovidae. *Nature* 254: 301–304.
- Vrba, E.S. 1982. Biostratigraphy and chronology, based particularly on Bovidae, of southern hominid associated assemblages: Makapansgat, Sterkfontein, Taung, Kromdraai, Swartkrans; also Elandsfontein (Saldanha), Broken Hill (now Kabwe) and Cave of Hearths. *Congrès International de Paléontologie Humaine, 1er Congrès* 2. Nice: CNRS.
- Walker, J, Cliff, R.A. & Lantham, A.G. 2006. U-Pb Isotopic Age of the StW 573 Hominid from Sterkfontein, South Africa. *Science* 314: 1592-1594.
- Wilkinson, M.J. 1973. *Sterkfontein cave system: evolution of a karst form*. Unpublished M.A. thesis, University of the Witwatersrand, Johannesburg.
- Wilkinson, M.J. 1983. Geomorphic perspectives on the Sterkfontein Australopithecine breccias. *Journal of Archaeological Science* 10: 515–529.
- Whittaker, J.C. & Kaldahl, E.J. 2001. Where the Waste Went: A Knappers' Dump at Grasshopper Pueblo. In: Andrefsky Jr. W. (ed.) *Lithic Debitage: Context, Form and Meaning*: 32-61. University of Utah Press, Salt Lake City.

Appendix A. - Sample of the Dump 21 Catalogue.

Art Number	Provenance	Raw Material	Basic type	Specific Type
Flakes				
1162/1/2	D21	Quartzite	Flake	Flake
1183	D21	Quartzite	Flake	Core Rejuvenation
1204	D21	Quartzite	Flake	Incomplete Flake
1198	D21	Quartzite	Flake	Core Trimming
1200	D21	Quartzite	Flake	Flake
1182	D21	Chert	Flake	Flake
1167	D21	Quartzite	Flake	Flake
1197	D21	Quartzite	Flake	Flake

Note that artefact 1162 naturally split into two pieces and is classified as artefact 1162/1/2.

Art Number	Provenance	Raw Material	Basic type	Specific Type	Flaking Pattern
Cores					
1194	D21	Quartzite	Core	Polyhedral core	Random
1193	D21	Quartzite	Core	Polyhedral core	Random
1174	D21	Quartzite	Core	Casual	Radial/Random
1166	D21	Quartzite	Core	Casual	Random
1171	D21	Quartzite	Core	Casual	Random
1173	D21	Quartzite	Core	Polyhedral core	Random
1205	D21	Quartzite	Core	Casual	Random
1195	D21	Quartzite	Core	Polyhedral core	Random
1180	D21	Quartzite	Core	Casual	Random
1177	D21	Quartzite	Core	Casual	Radial/Irregular
1190	D21	Quartzite	Core	Polyhedral core Incomplete discoidal core	Random
1164	D21	Quartzite	Core		Radial
1006	D21	Quartzite	Core Tool	Unifacial Handaxe	Lateral Trimming
1004	D21	Quartzite	Core	Casual	casual
1007	D21	Quartzite	Core	Polyhedral core	Random
1175	D21	Quartzite	Core	Polyhedral core	Random
1001	D21	Quartzite	Core	Polyhedral core	Random
1168	D21	Quartzite	Core	Polyhedral core	Random
1165	D21	Quartzite	Core	Polyhedral core	Random
1191	D21	Quartzite	Core	Polyhedral core	Random
1181	D21	Quartzite	Core	Polyhedral core	Random
1172	D21	Quartzite	Core	Polyhedral core Incomplete discoidal core	Random
1000	D21	Quartzite	Core		Radial
1161	D21	Quartzite	Manuport		
1003	D21	Quartzite	Core	Polyhedral core	Random
1179	D21	Quartzite	Core	Polyhedral core	Random
1005	D21	Quartzite	Core	Discoidal core	Radial

Appendix B- Name Chamber artefacts by excavation square

As presented in Chapter 3 the Name Chamber assemblage was excavated from 18 squares of varying depth. Spits of 30cm were excavated into the soft deposit on the Western Talus. The depths reached were influenced by the stability of the talus cone and access to the excavation areas. The data presented in this appendix is arranged in alphabetical order of the squares excavated. For a presentation of these squares and how they relate to the excavations see Figures 3.3 – 3.7 in Chapter 3.

Square A - Artefact distribution ≥ 20 mm and < 20 mm

■ ≥ 20 mm
 ■ 10-19mm
 ■ 0 - 9mm

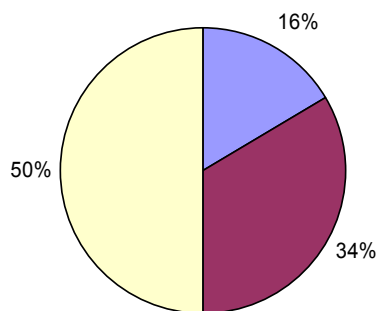

Square A - Artefact distribution

■ 30-60cm ■ 60-90cm
■ 90-120cm ■ 120-150cm

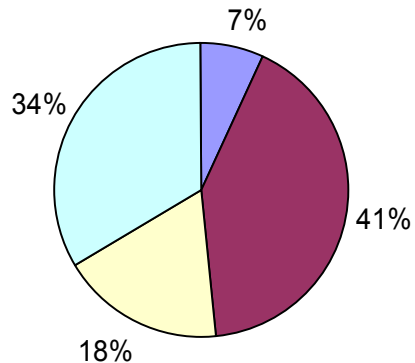

Square A - Raw material distribution

■ Quartz ■ Chert ■ Quartzite

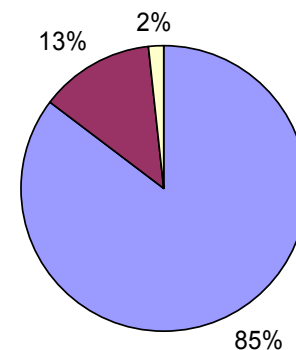

Square A – Artefact Analysis

Square A - Artefact weathering condition

■ fresh ■ abraded ■ weathered

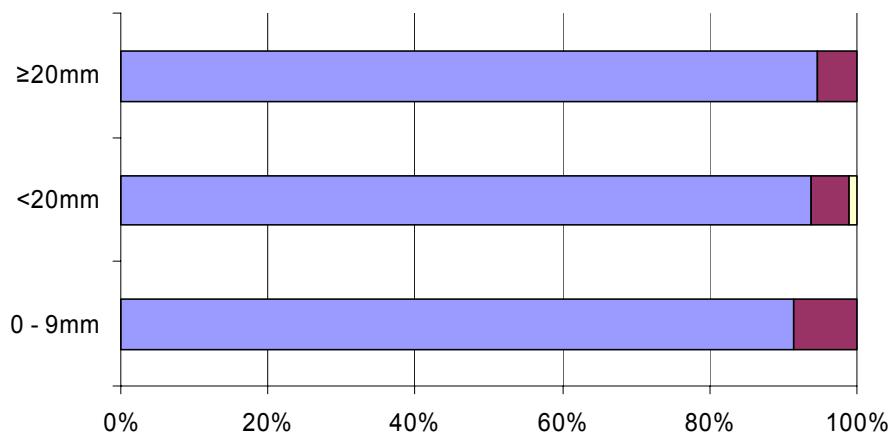

Square A - Artefact size and distribution

■ 30-60cm ■ 60-90cm ■ 90-120cm ■ 120-150cm

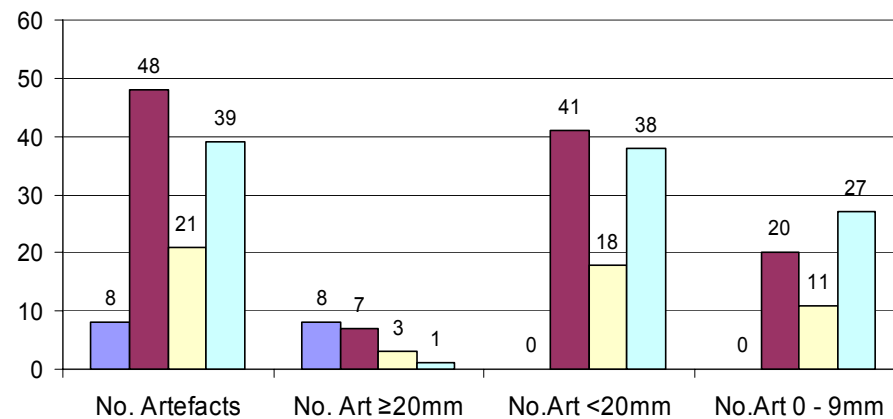

Square B - Artefact distribution $\geq 20\text{mm}$ <math>< 20\text{mm}</math>

■ $\geq 20\text{mm}$
■ 10 - 19mm
 ■ 0 - 9mm

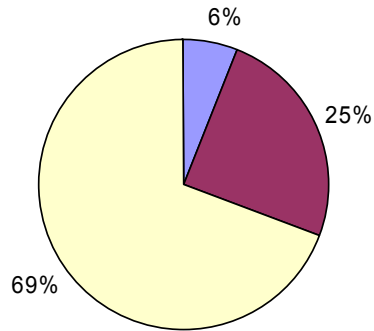

Square B - Artefact distribution

■ 60-90cm
 ■ 90-120cm

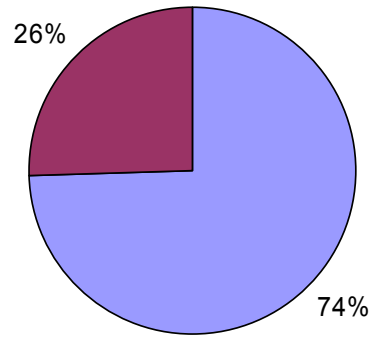

Square B - Raw material distribution

■ Quartz
 ■ Chert
 ■ Quartzite

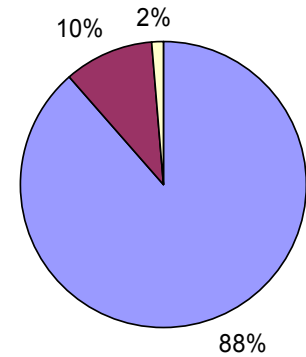

Square B – Artefact Analysis

Square B - Artefact weathering condition

■ fresh
 ■ abraded
 ■ weathered

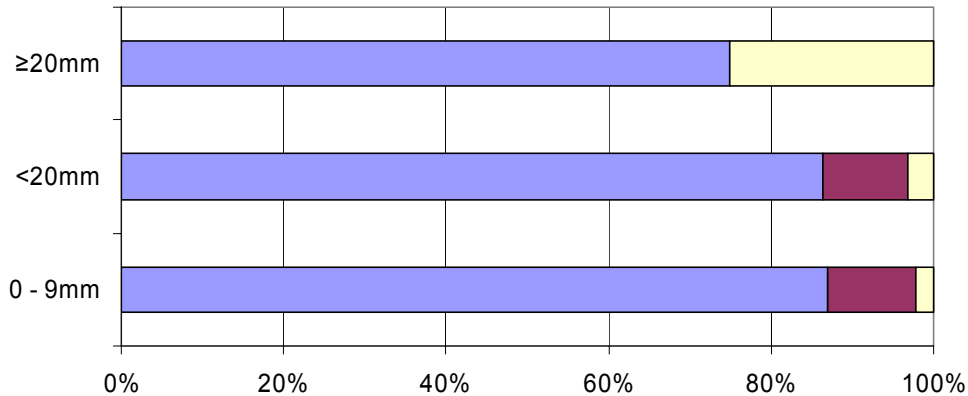

Square B - Artefact size and distribution

■ 60-90cm
 ■ 90-120cm

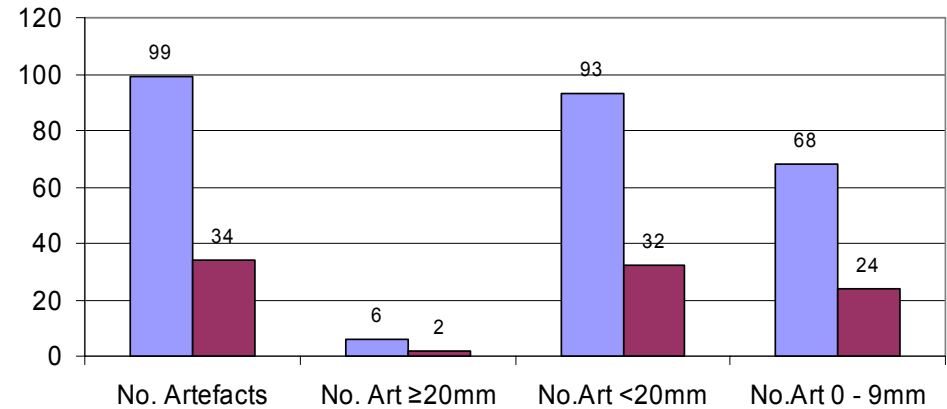

Square C - Artefact distribution $\geq 20\text{mm}$ <math><20\text{mm}</math>

■ $\geq 20\text{mm}$
 ■ 10 - 19mm
 ■ 0 - 9mm

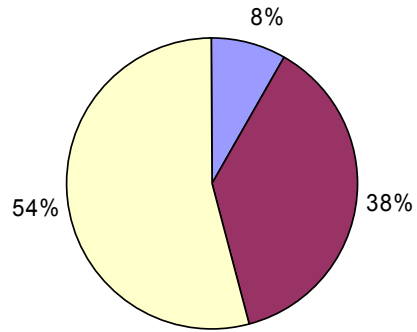

Square C - Raw material distribution

■ Quartz
 ■ Chert
 ■ Quartzite

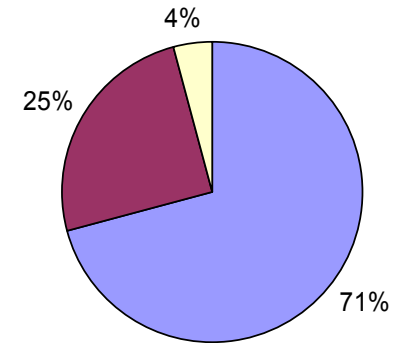

Square C – Artefact Analysis

Square C - Artefact weathering condition

■ fresh
 ■ abraded
 ■ weathered

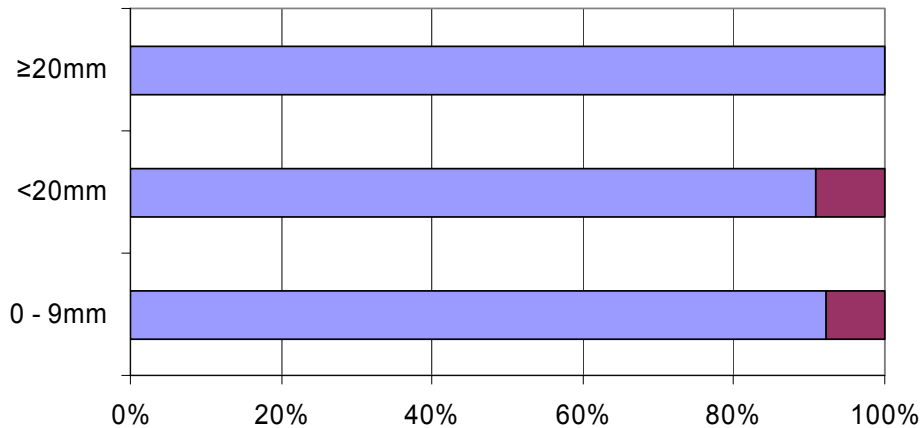

Square C - Artefact size and distribution

■ 0-30cm

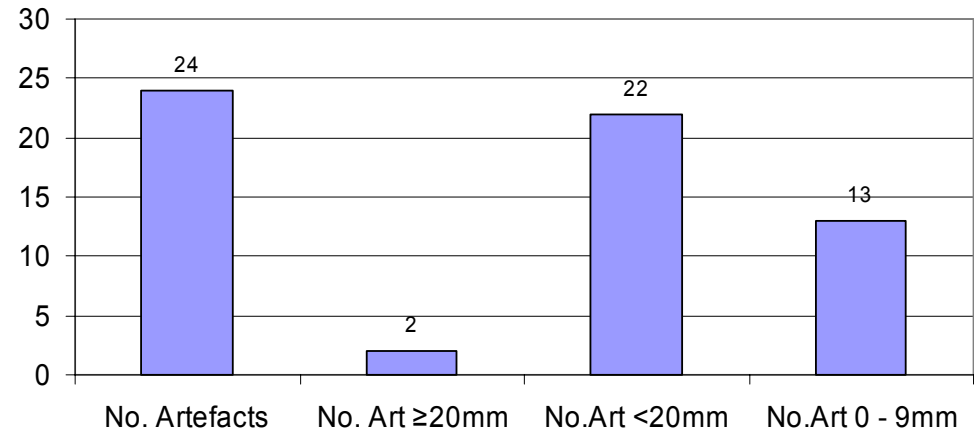

Square D - Artefact distribution $\geq 20\text{mm}$

<20mm
 ■ $\geq 20\text{mm}$ ■ 10 - 19mm ■ 0 - 9mm

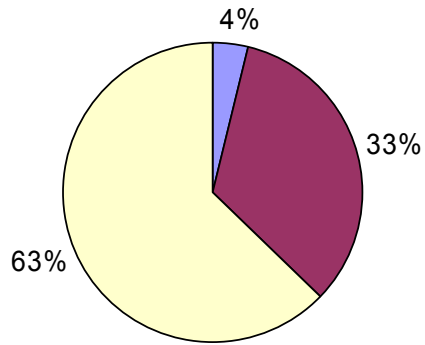

Square D - Artefact distribution

■ 0-30cm ■ 30-60cm ■ 60-90cm

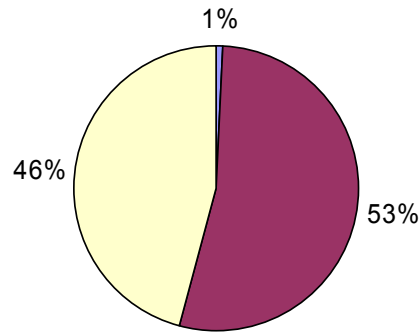

Square D - Raw material distribution

■ Quartz ■ Chert ■ Quartzite

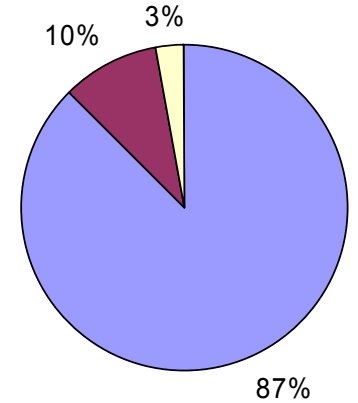

Square D – Artefact Analysis

Square D - Artefact weathering condition

■ fresh ■ abraded ■ weathered

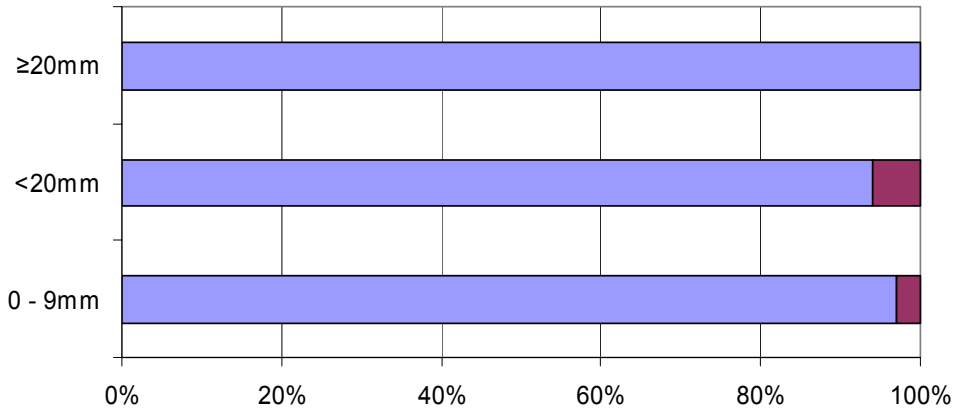

Square D - Artefact size and distribution

■ 0-30cm ■ 30-60cm ■ 60-90cm

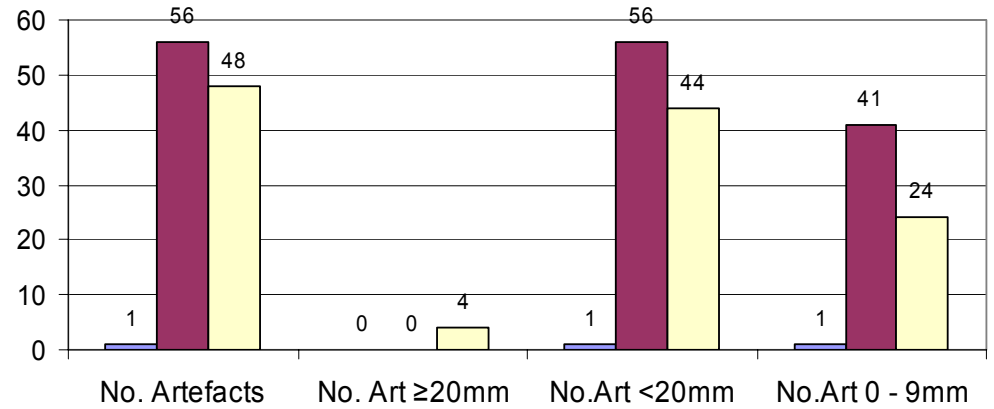

Square E - Artefact distribution $\geq 20\text{mm}$ and $< 20\text{mm}$

■ $\geq 20\text{mm}$
■ 10 - 19mm
 ■ 0 - 9mm

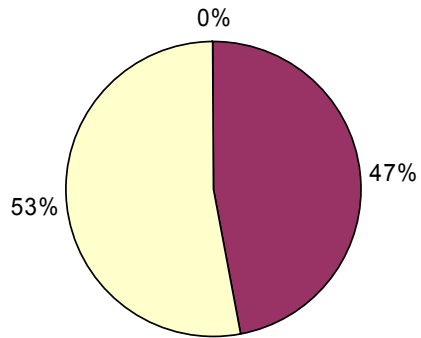

Square E - Raw material distribution

■ Quartz
 ■ Chert
 ■ Quartzite

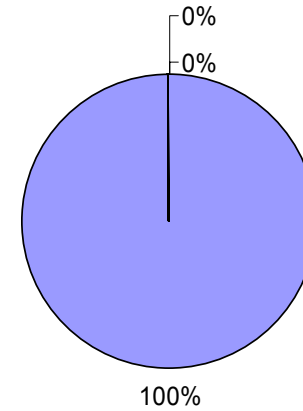

Square E – Artefact Analysis

Square E - Artefact weathering condition

■ fresh
 ■ abraded
 ■ weathered

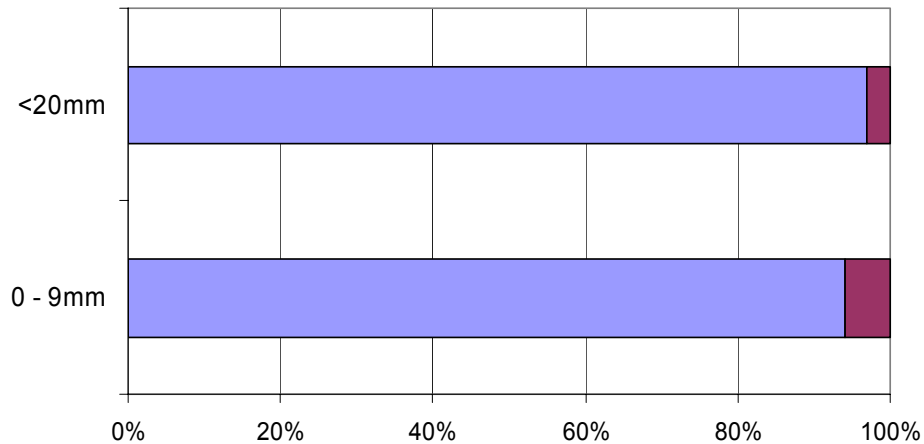

Square E - Artefact size and distribution

■ 0-30cm

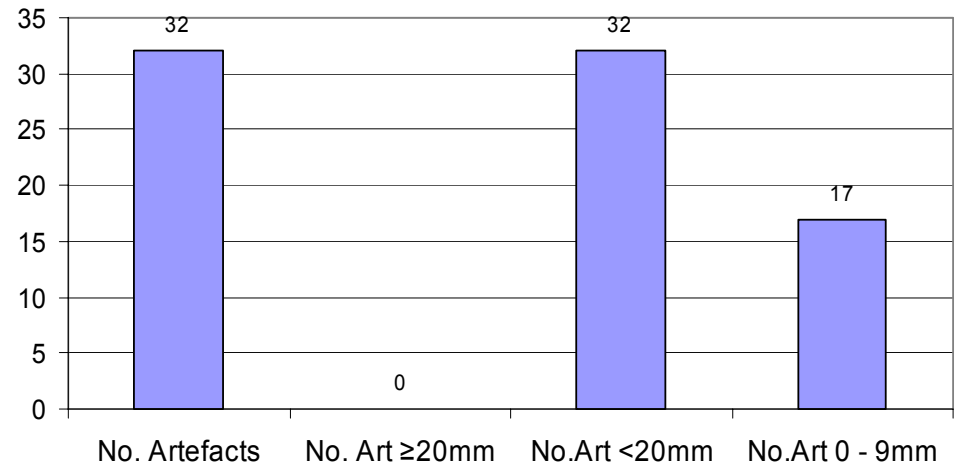

Square F - Artefact distribution $\geq 20\text{mm}$ and $< 20\text{mm}$

■ $\geq 20\text{mm}$
■ 10 - 19mm
 ■ 0 - 9mm

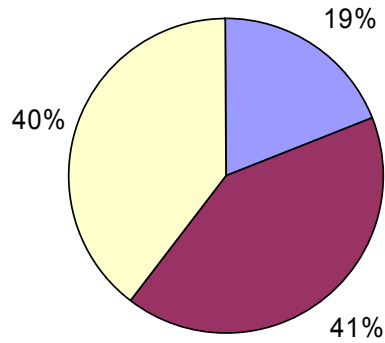

Square F - Artefact distribution

■ 30-60cm
 ■ 60-90cm

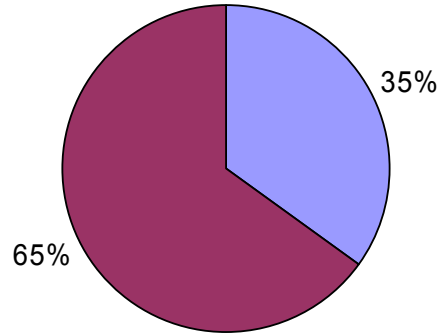

Square F - Raw material distribution

■ Quartz
 ■ Chert
 ■ Quartzite

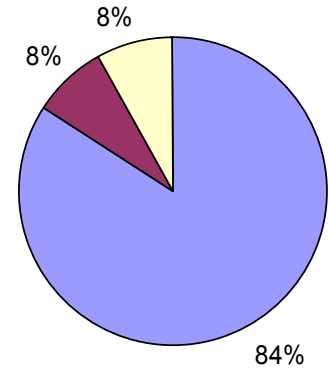

Square F – Artefact Analysis

Square F - Artefact weathering condition

■ fresh
 ■ abraded
 ■ weathered

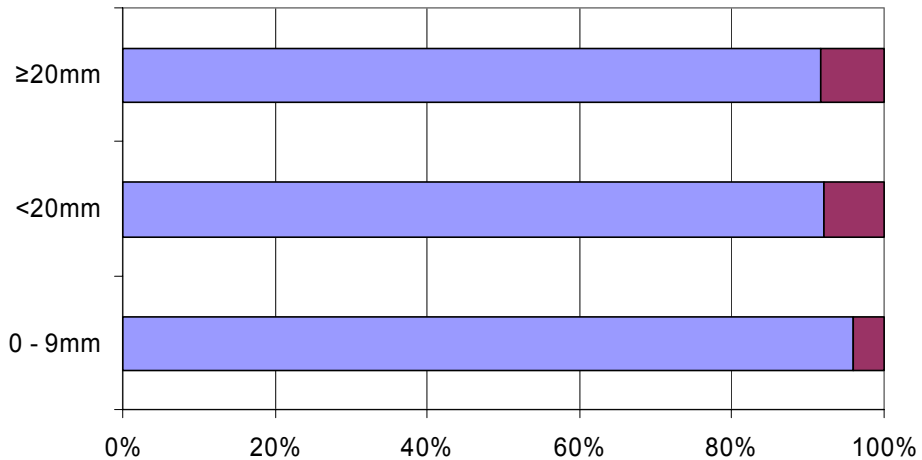

Square F - Artefact size and distribution

■ 30-60cm
 ■ 60-90cm

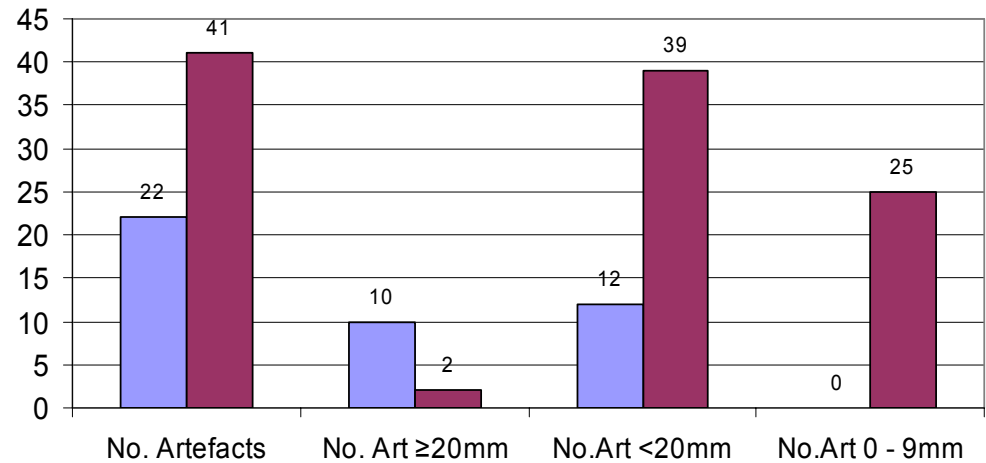

Square G- Artefact distribution $\geq 20\text{mm}$ and $< 20\text{mm}$

■ $\geq 20\text{mm}$ ■ 10 - 19mm ■ 0 - 9mm

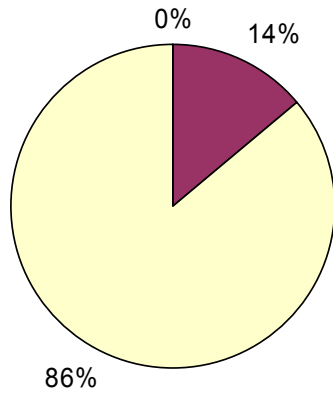

Square G - Artefact distribution

■ 30-60cm ■ 60-90cm ■ 90-120cm

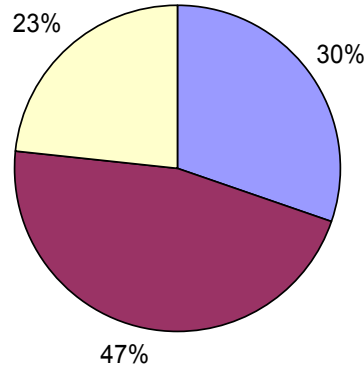

Square G - Raw material distribution

■ Quartz ■ Chert ■ Quartzite

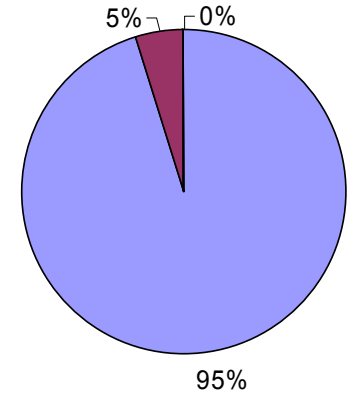

Square G – Artefact Analysis

Square G - Artefact weathering condition

■ fresh ■ abraded ■ weathered

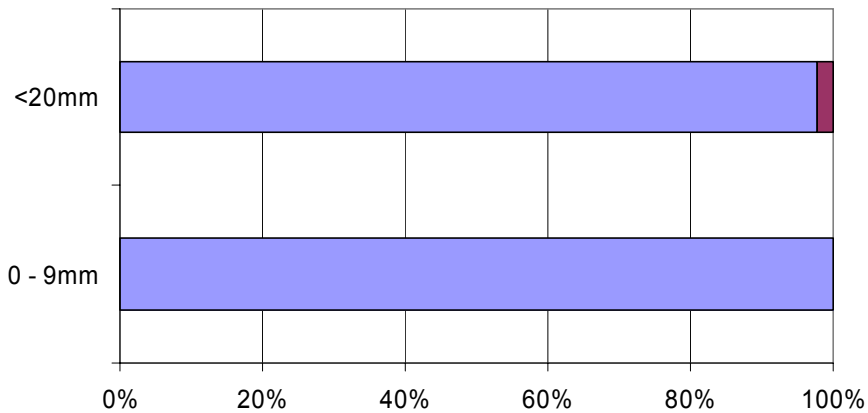

Square G - Artefact size and distribution

■ 30-60cm ■ 60-90cm ■ 90-120cm

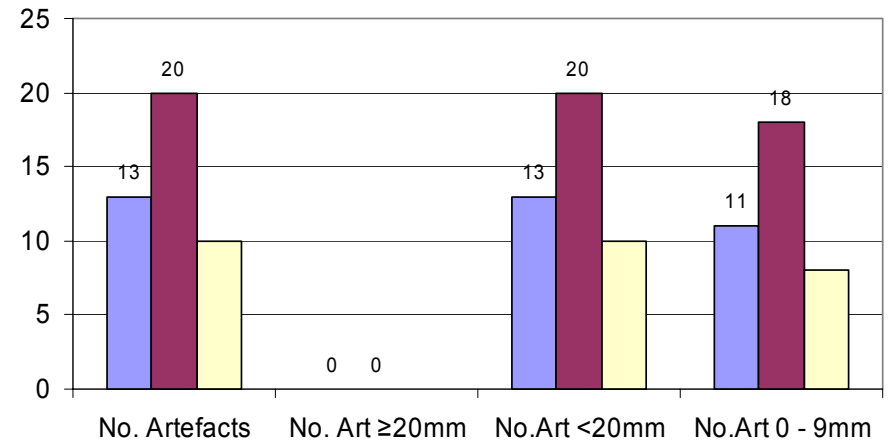

Square H- Artefact distribution ≥ 20 mm and < 20 mm

■ ≥ 20 mm
 ■ 10 - 19mm
 ■ 0 - 9mm

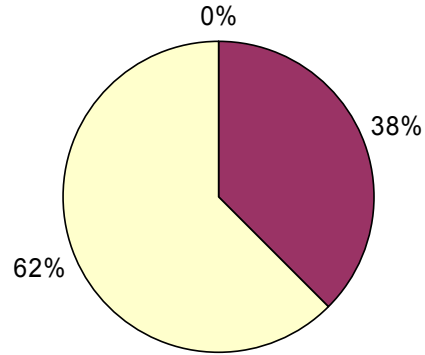

Square H - Raw material distribution

■ Quartz
 ■ Chert
 ■ Quartzite

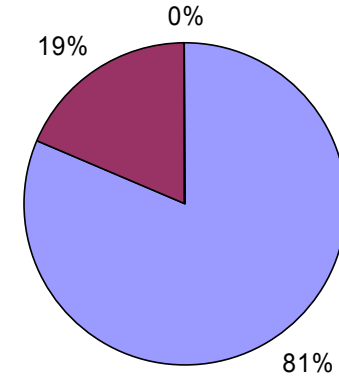

Square H – Artefact Analysis

Square H - Artefact weathering condition

■ fresh
 ■ abraded
 ■ weathered

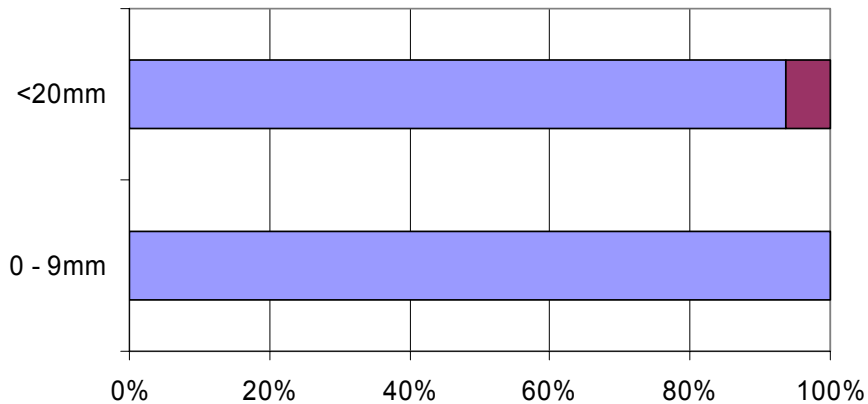

Square H - Artefact size and distribution

■ 0-30cm

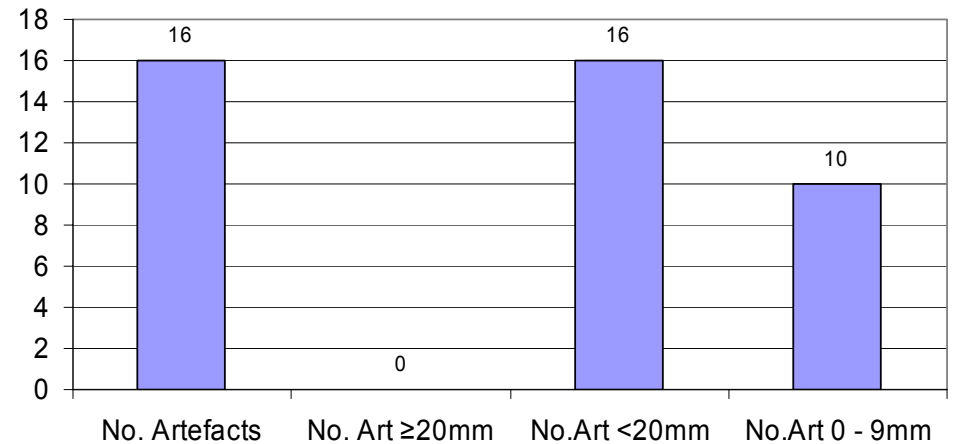

Square I- Artefact distribution ≥ 20 mm and < 20 mm

■ ≥ 20 mm ■ 10 - 19mm ■ 0 - 9mm

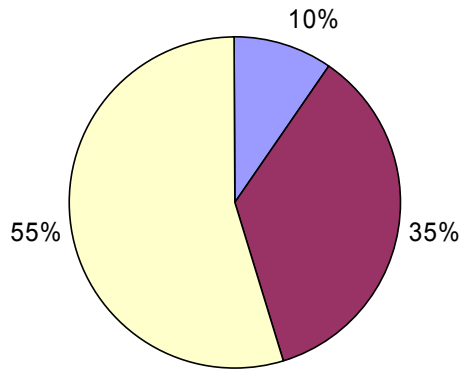

Square I - Raw material distribution

■ Quartz ■ Chert ■ Quartzite

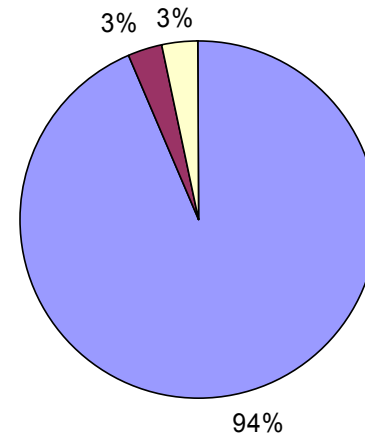

Square I – Artefact Analysis

Square I - Artefact weathering condition

■ fresh ■ abraded ■ weathered

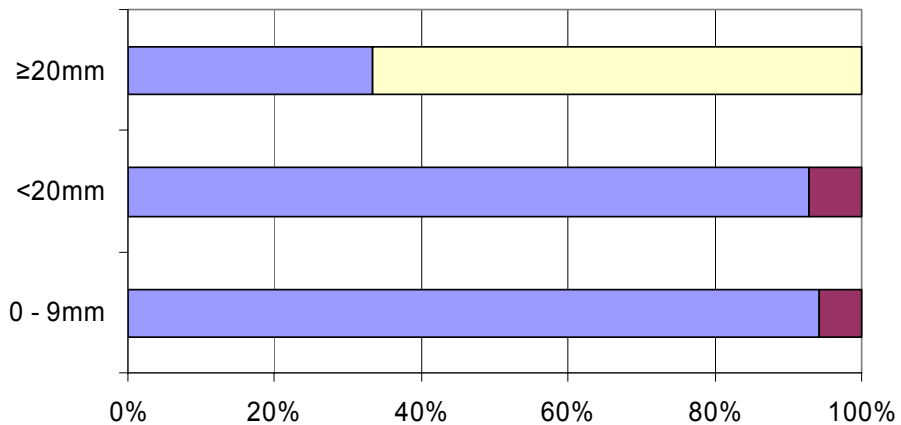

Square I - Artefact size and distribution

■ 30-60cm

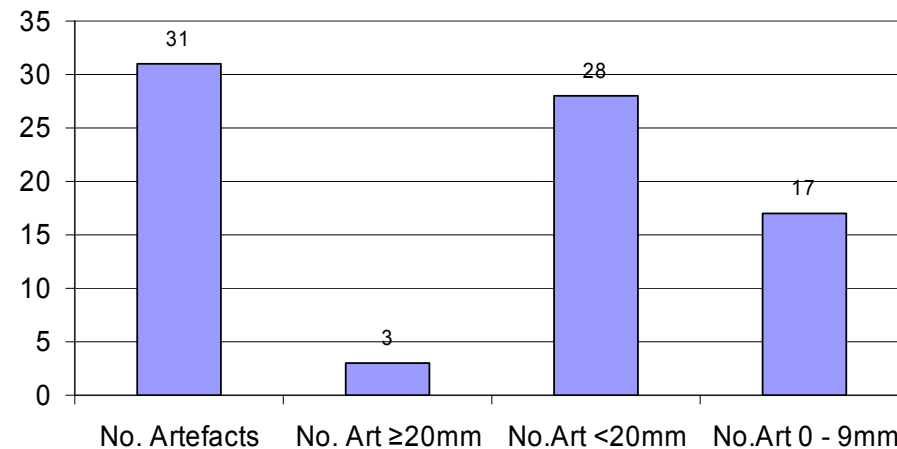

Square J- Artefact distribution $\geq 20\text{mm}$ and $< 20\text{mm}$

$\geq 20\text{mm}$ 10 - 19mm 0 - 9mm

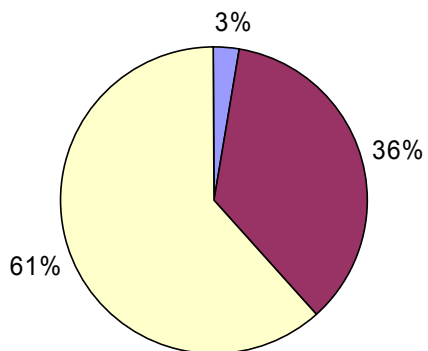

Square J - Artefact distribution

30-60cm 60-90cm
90-120cm 120-150cm

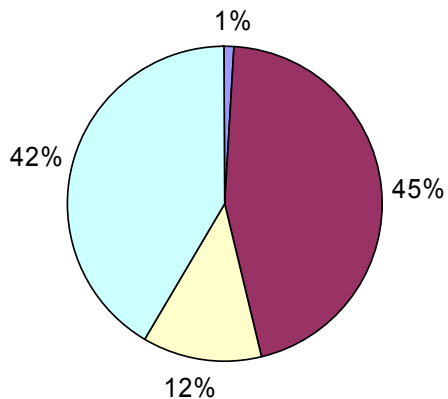

Square J - Raw material distribution

Quartz Chert Quartzite

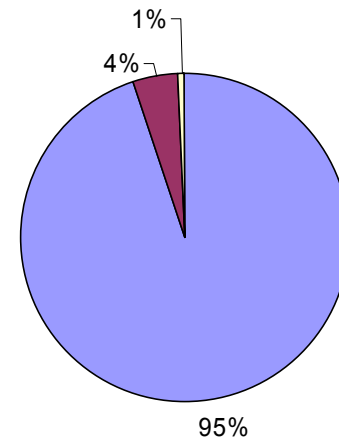

Square J – Artefact Analysis

Square J - Artefact weathering condition

fresh abraded weathered

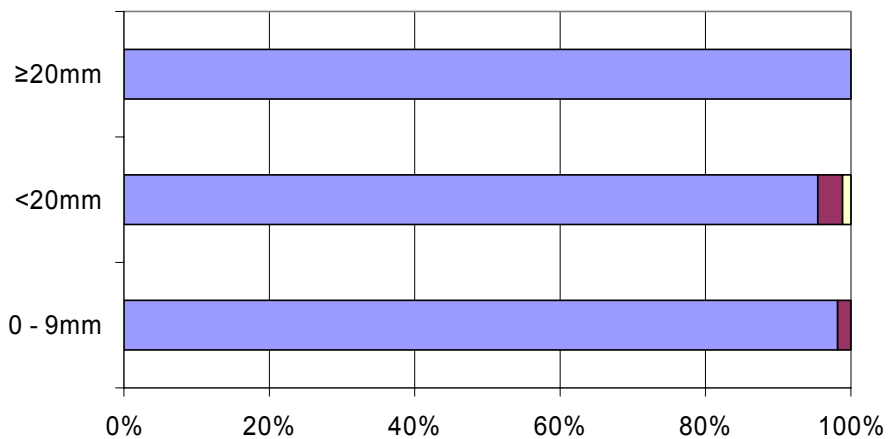

Square J - Artefact size and distribution

30-60cm 60-90cm 90-120cm 120-150cm

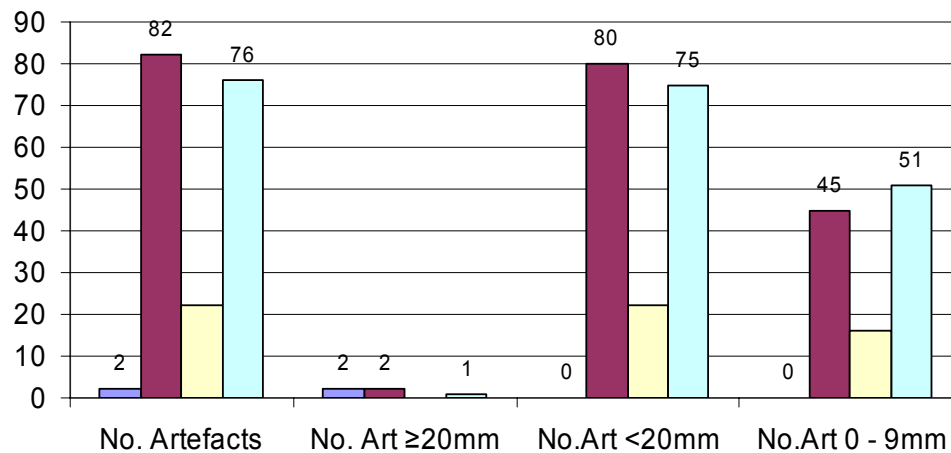

Square K - Artefact distribution $\geq 20\text{mm}$ and $< 20\text{mm}$

■ $\geq 20\text{mm}$
 ■ 10 - 19mm
 ■ 0 - 9mm

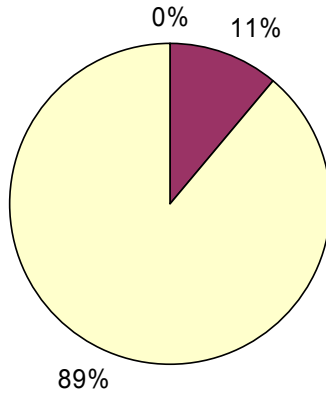

Square K - Raw material distribution

■ Quartz
 ■ Chert
 ■ Quartzite

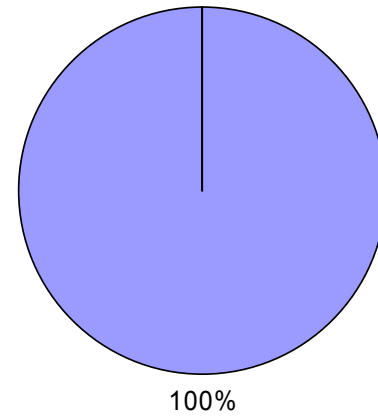

Square K – Artefact Analysis

Square K - Artefact weathering condition

■ fresh
 ■ abraded
 ■ weathered

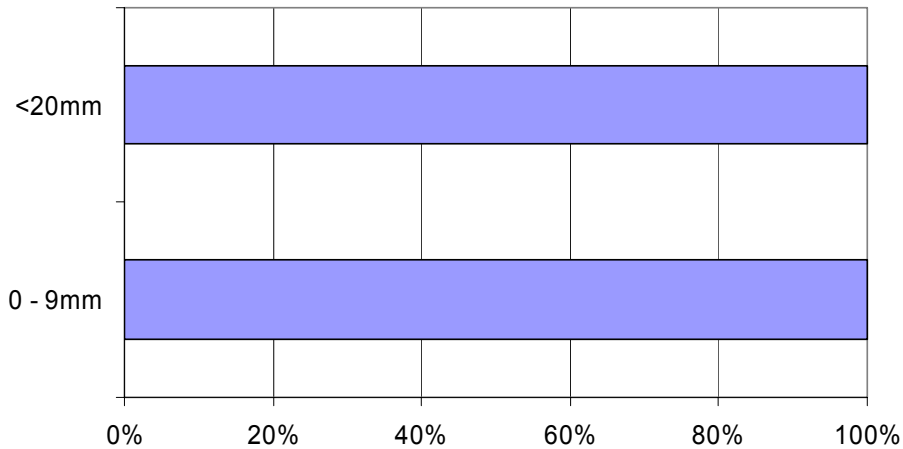

Square K - Artefact size and distribution

■ 30-60cm

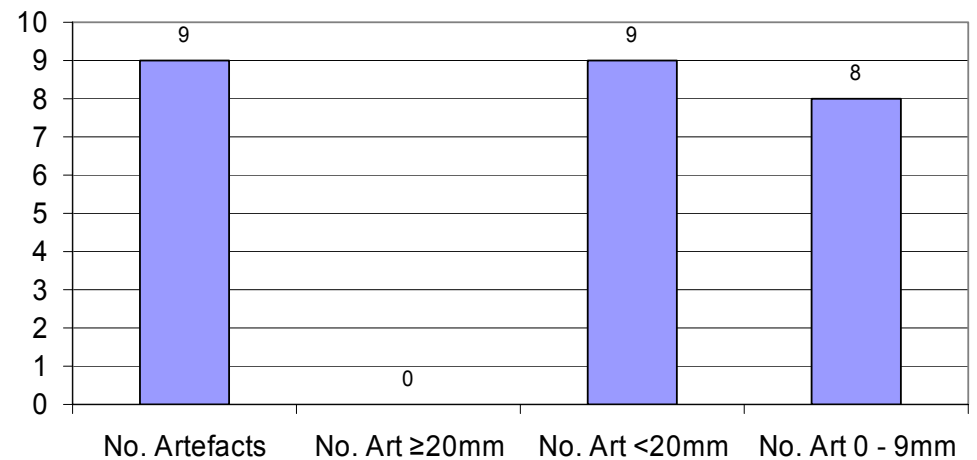

Square L - Artefact distribution ≥ 20 mm and < 20 mm

■ ≥ 20 mm
 ■ 10 - 19mm
 ■ 0 - 9mm

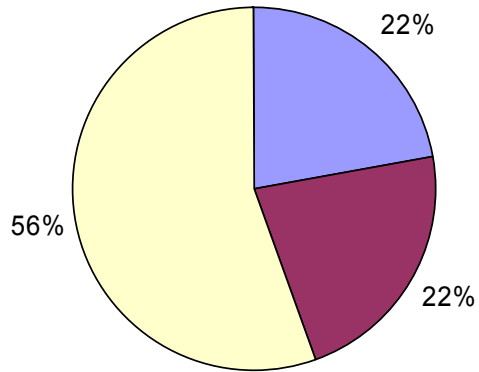

Square L - Raw material distribution

■ Quartz
 ■ Chert
 ■ Quartzite

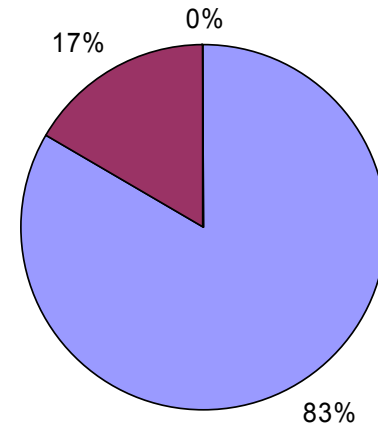

Square L – Artefact Analysis

Square L - Artefact weathering condition

■ fresh
 ■ abraded
 ■ weathered

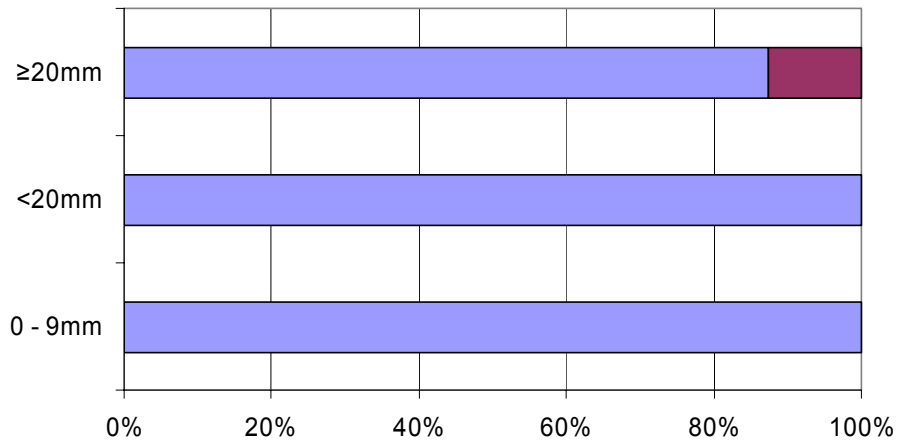

Square L - Artefact size and distribution

■ 0-30cm

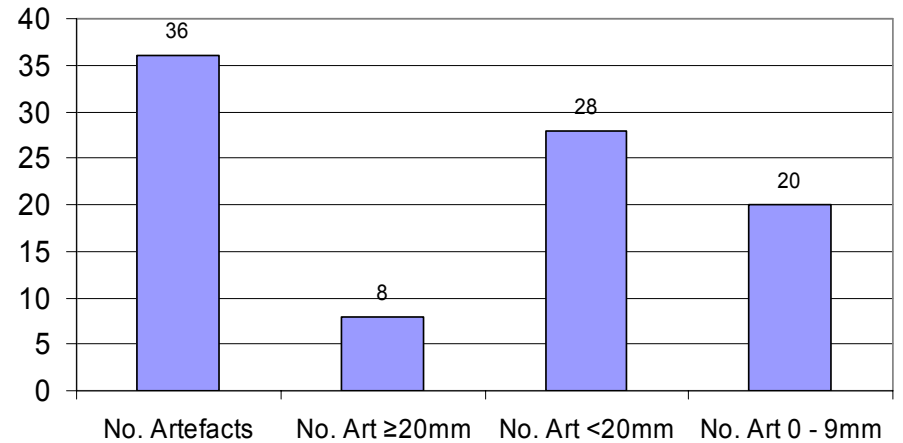

Square M - Artefact distribution $\geq 20\text{mm}$ and $< 20\text{mm}$

■ $\geq 20\text{mm}$
 ■ 10 - 19mm
 ■ 0 - 9mm

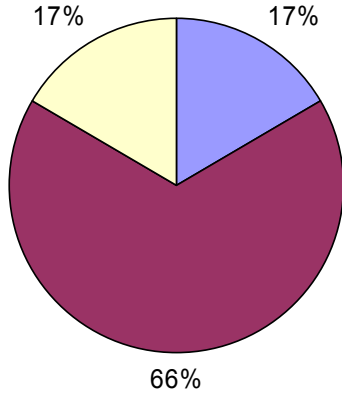

Square M - Raw material distribution

■ Quartz
 ■ Chert
 ■ Quartzite

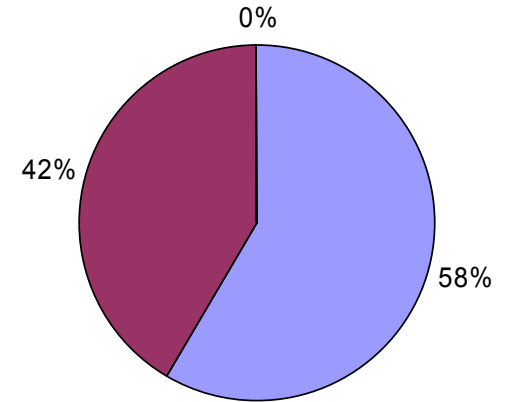

Square M – Artefact Analysis

Square M - Artefact weathering condition

■ fresh
 ■ abraded
 ■ weathered

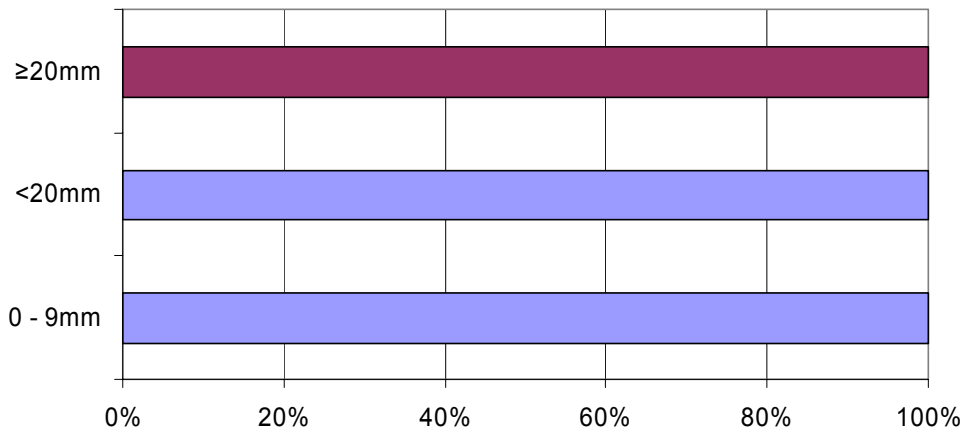

Square M - Artefact size and distribution

■ 30-60cm

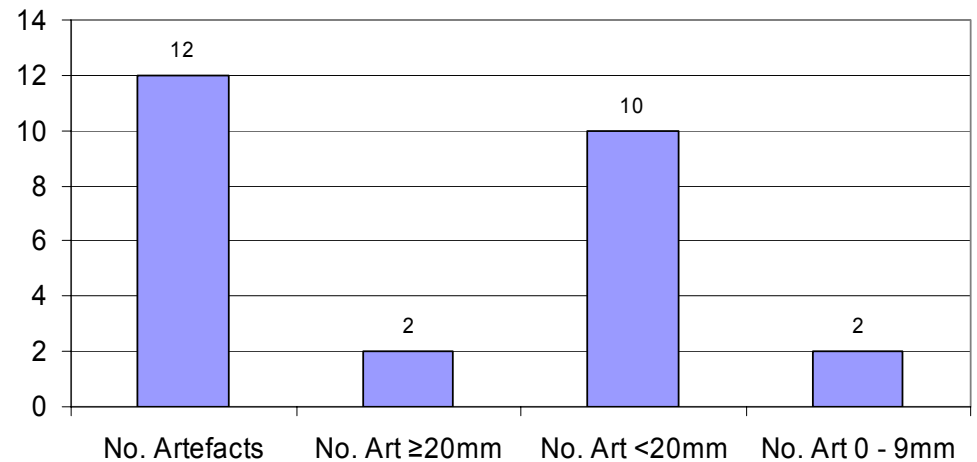

Square N - Artefact distribution $\geq 20\text{mm}$ and $< 20\text{mm}$

■ $\geq 20\text{mm}$
 ■ 10 - 19mm
 ■ 0 - 9mm

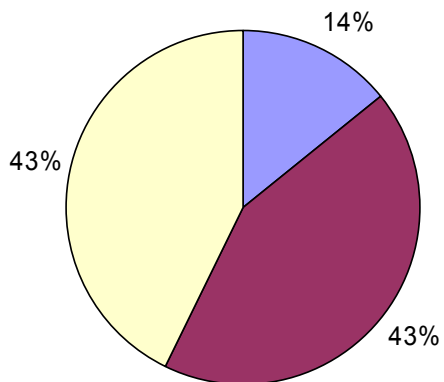

Square N - Artefact distribution

■ 0-30cm
 ■ 30-60cm
 ■ 60-90cm

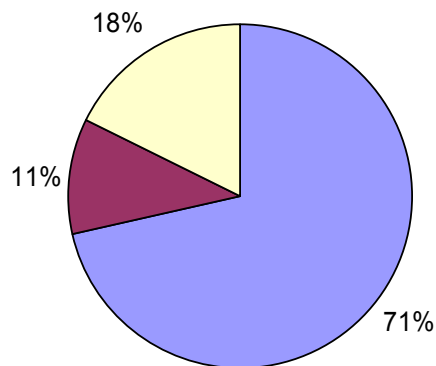

Square N - Raw material distribution

■ Quartz
 ■ Chert
 ■ Quartzite

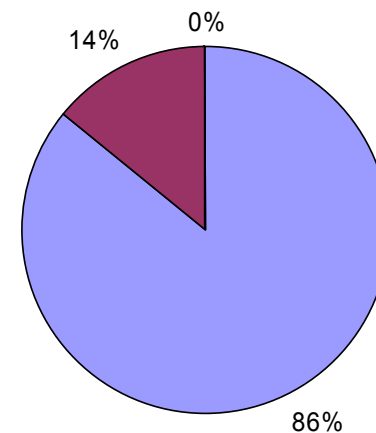

Square N – Artefact Analysis

Square N - Artefact weathering condition

■ fresh
 ■ abraded
 ■ weathered

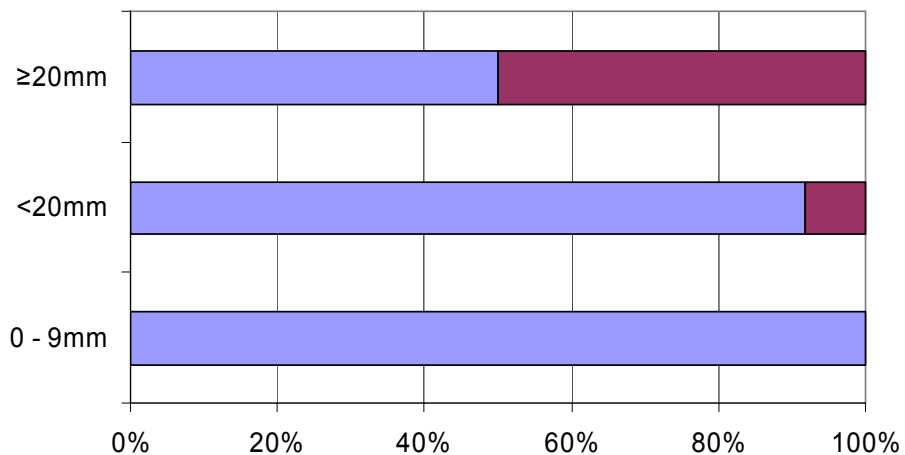

Square N - Artefact size and distribution

■ 0-30cm
 ■ 30-60cm
 ■ 60-90cm

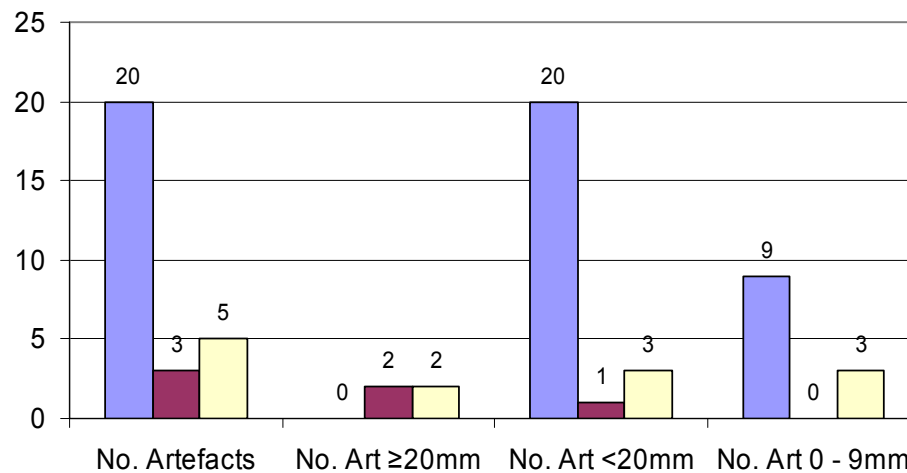

Square O - Artefact distribution ≥ 20 mm and < 20 mm

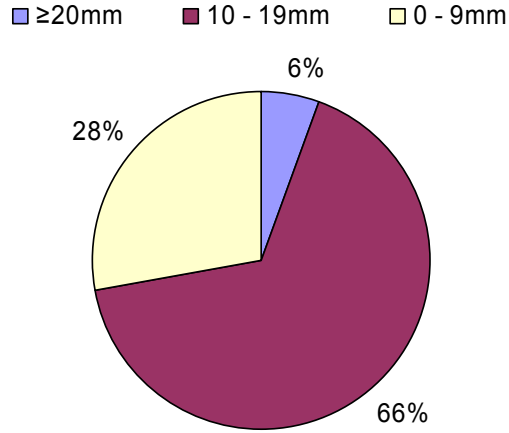

Square O - Raw material distribution

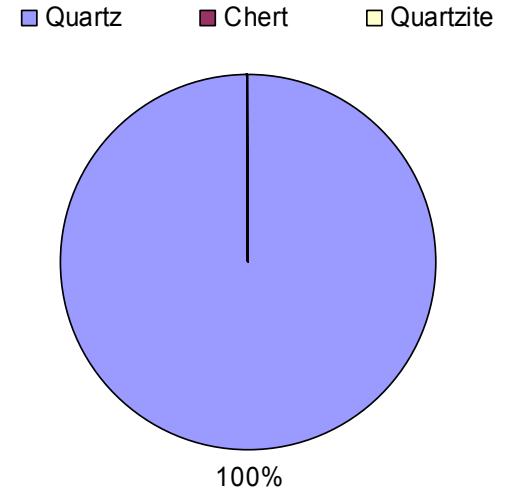

Square O – Artefact Analysis

Square O - Artefact weathering condition

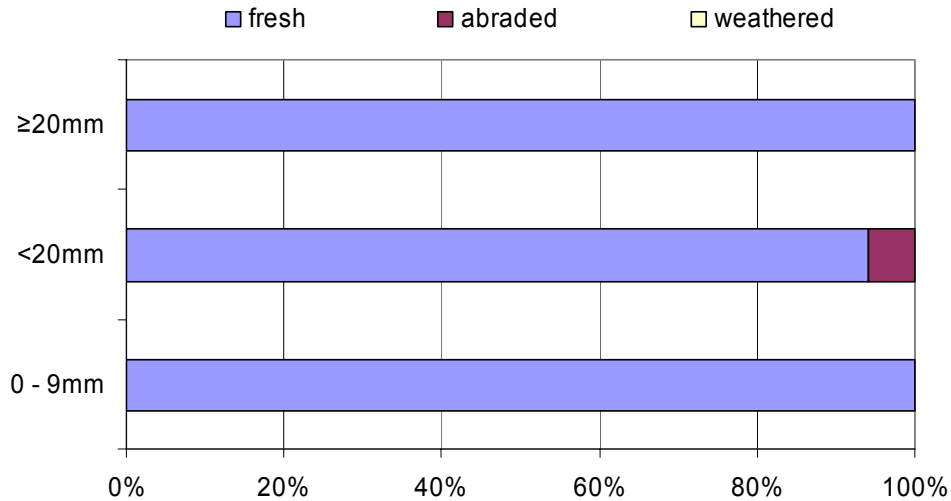

Square O - Artefact size and distribution

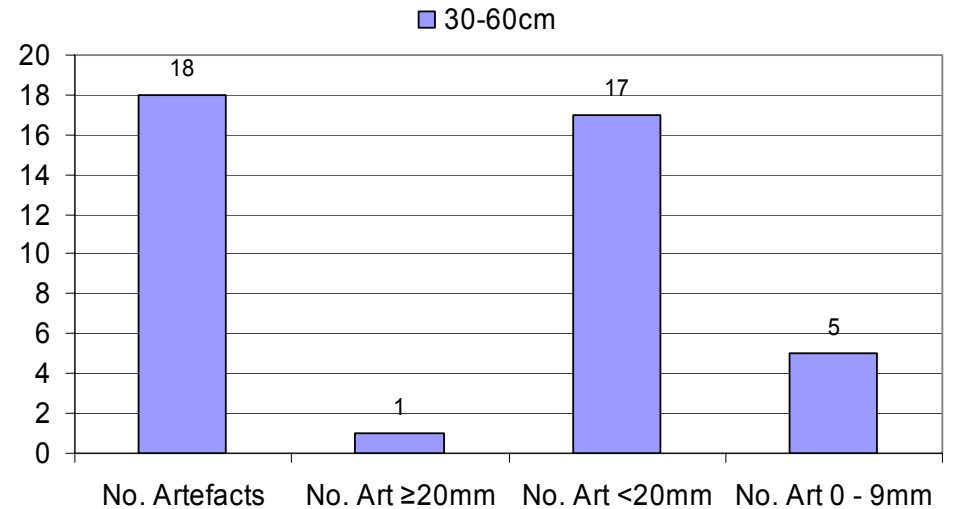

Square P - Artefact distribution $\geq 20\text{mm}$ and $< 20\text{mm}$

■ $\geq 20\text{mm}$
■ 10 - 19mm
 ■ 0 - 9mm

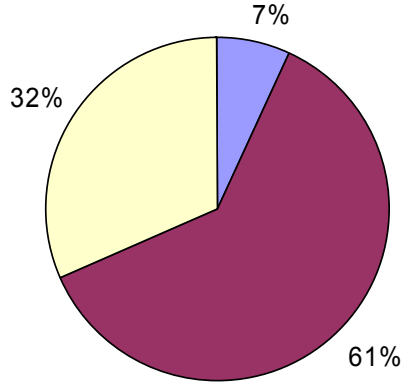

Square P - Artefact distribution

■ 0-30cm
 ■ 90-120cm

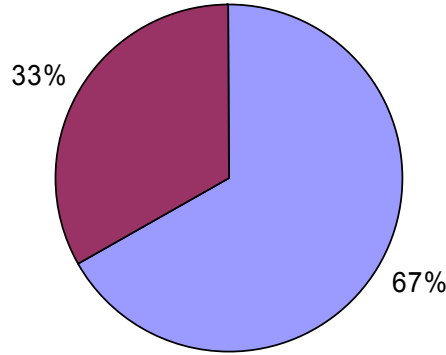

Square P - Raw material distribution

■ Quartz
 ■ Chert
 ■ Quartzite

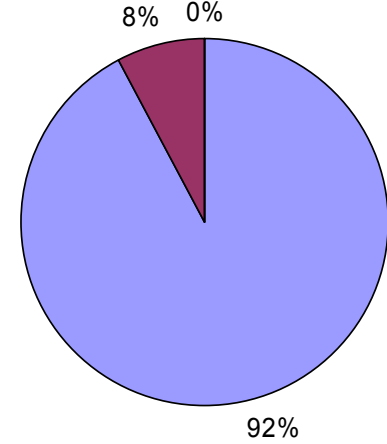

Square P – Artefact Analysis

Square P - Artefact weathering condition

■ fresh
 ■ abraded
 ■ weathered

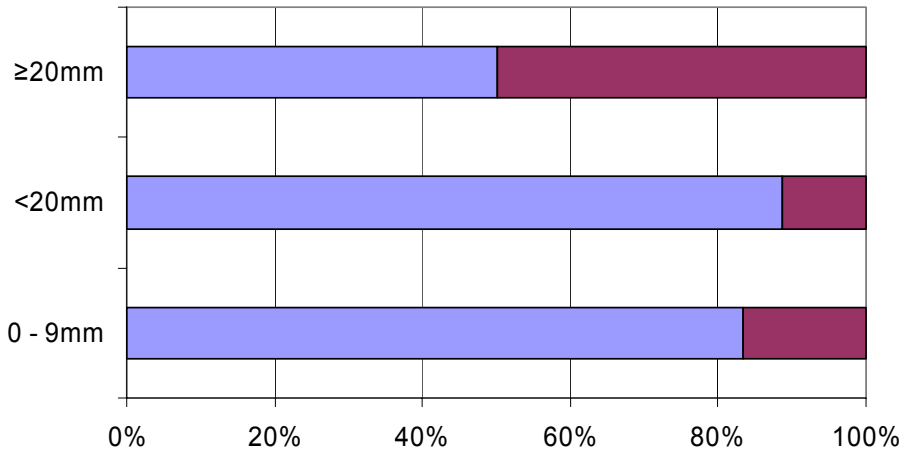

Square P - Artefact size and distribution

■ 0-30cm
 ■ 90-120cm

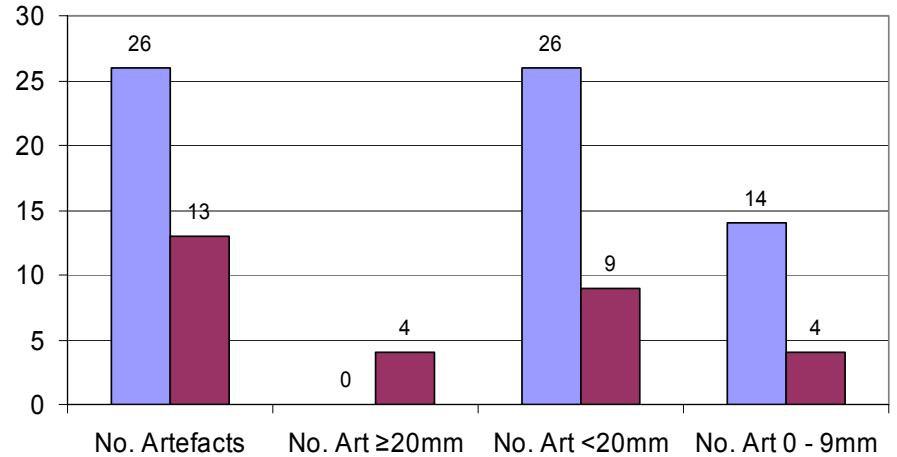

Square Q - Artefact distribution $\geq 20\text{mm}$ and $< 20\text{mm}$

■ $\geq 20\text{mm}$
 ■ 10 - 19mm
 ■ 0 - 9mm

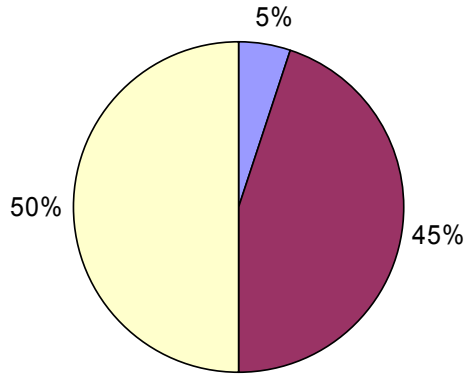

Square Q - Artefact distribution

■ 0-30cm
 ■ 30-60cm
 ■ 60-90cm
 ■ 90-120cm

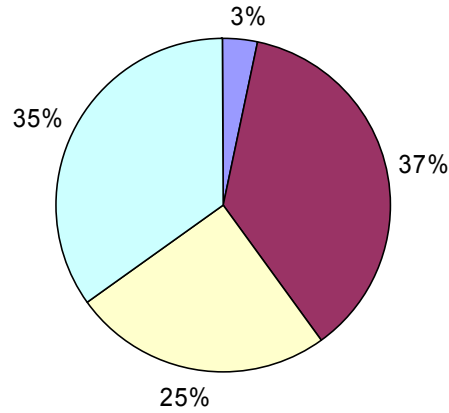

Square Q - Raw material distribution

■ Quartz
 ■ Chert
 ■ Quartzite

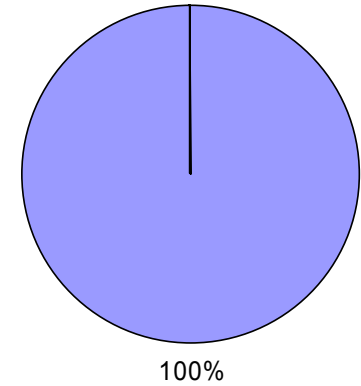

Square Q – Artefact Analysis

Square Q - Artefact weathering condition

■ fresh
 ■ abraded
 ■ weathered

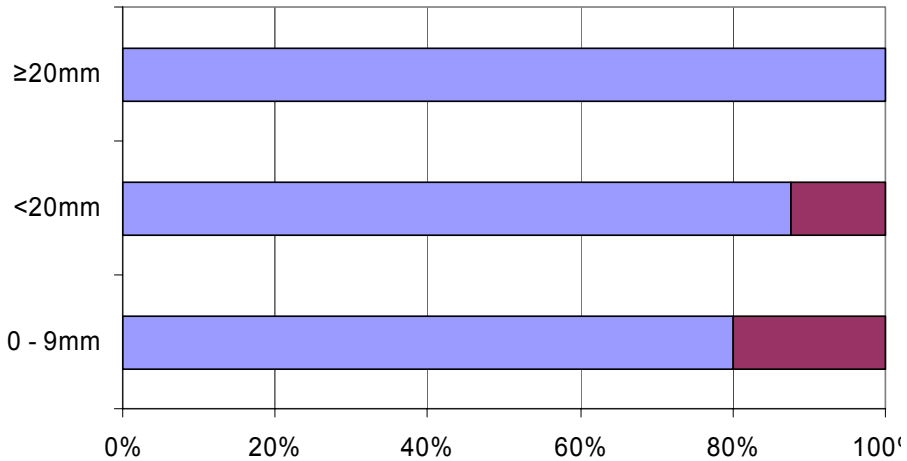

Square Q - Artefact size and distribution

■ 0-30cm
 ■ 30-60cm
 ■ 60-90cm
 ■ 90-120cm

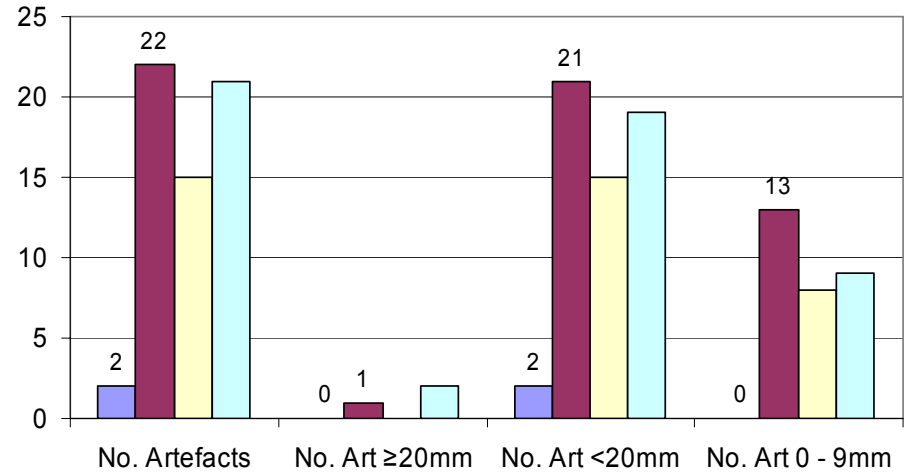

Square R - Artefact distribution $\geq 20\text{mm}$ and $< 20\text{mm}$

■ $\geq 20\text{mm}$ ■ 10 - 19mm ■ 0 - 9mm

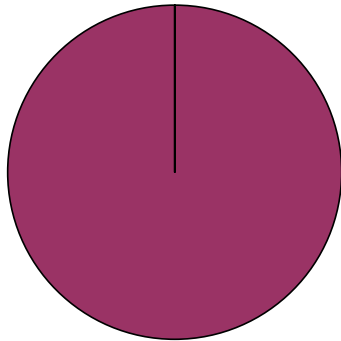

100%

Square R - Raw material distribution

■ Quartz ■ Chert ■ Quartzite

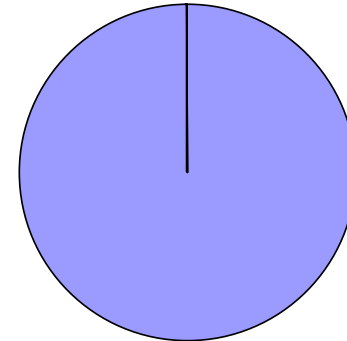

100%

Square R – Artefact Analysis

Square R - Artefact weathering condition

■ fresh ■ abraded ■ weathered

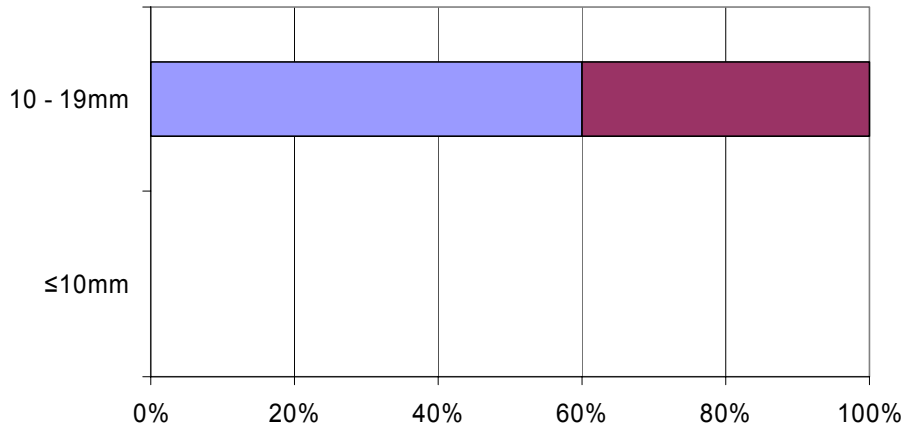

Square R - Artefact size and distribution

■ 30-60cm

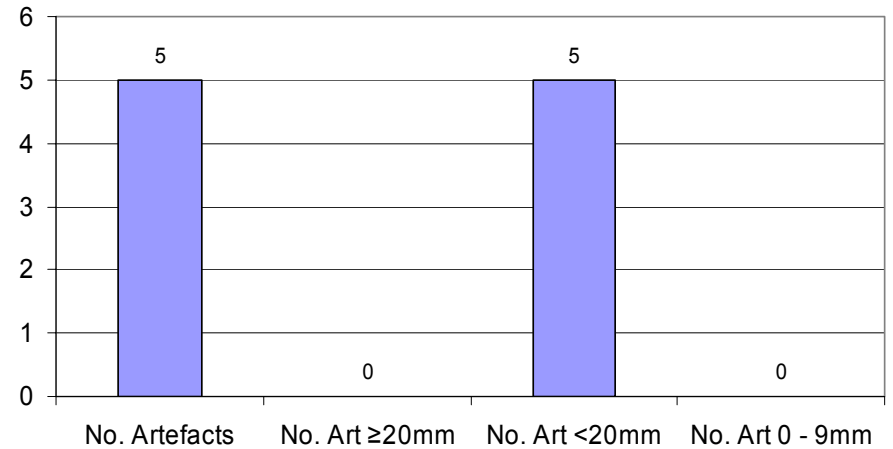

Lost Context - Artefact distribution $\geq 20\text{mm}$ and $< 20\text{mm}$

■ $\geq 20\text{mm}$
 ■ 10 - 19mm
 ■ 0 - 9mm

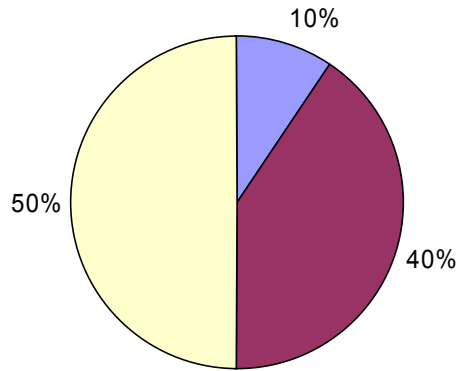

Lost Context - Artefact distribution

■ 30-60cm
 ■ 90-120cm
 ■ Loose

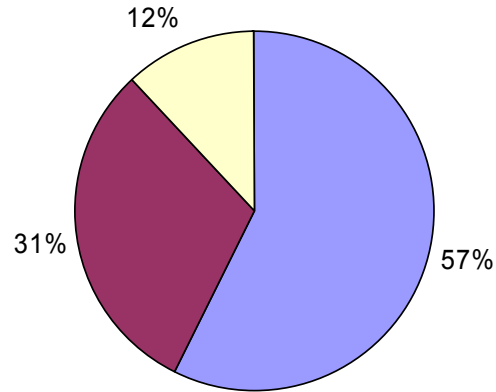

Lost Context - Raw material distribution

■ Quartz
 ■ Chert
 ■ Quartzite

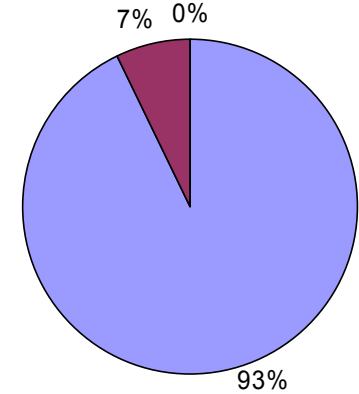

Lost Context (From 2000) – Artefact Analysis

Lost Context - Artefact weathering condition

■ fresh
 ■ abraded
 ■ weathered

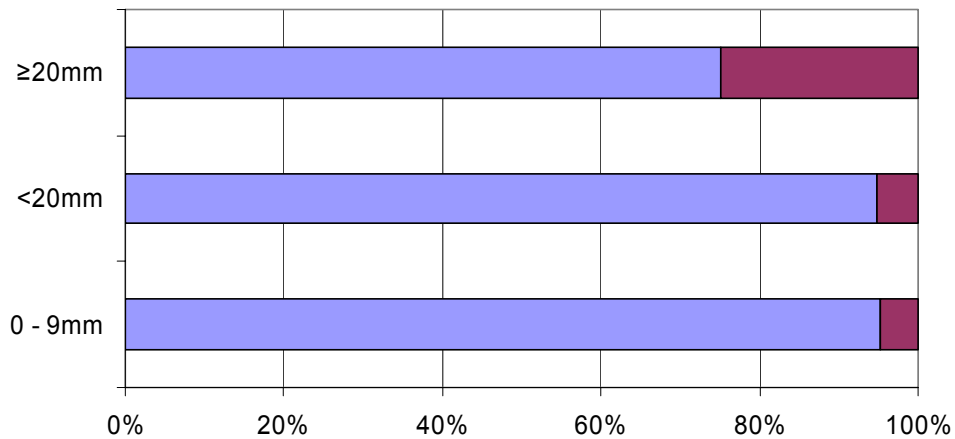

Lost Context - Artefact size and distribution

■ 30-60cm
 ■ 90-120cm
 ■ Loose

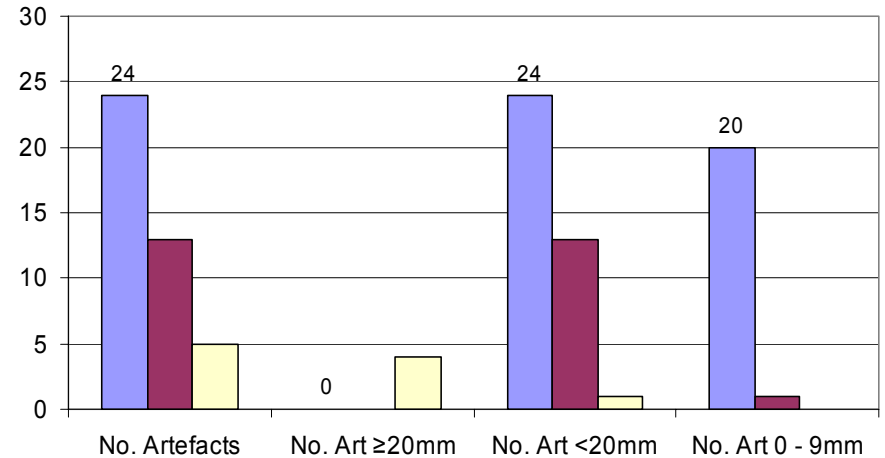

Lower Talus - Artefact distribution ≥ 20 mm and < 20 mm

■ ≥ 20 mm ■ 10 - 19mm ■ 0 - 9mm

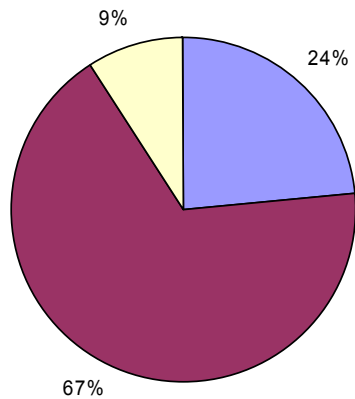

Lower Talus - Raw material distribution

■ Quartz ■ Chert ■ Quartzite ■ Other

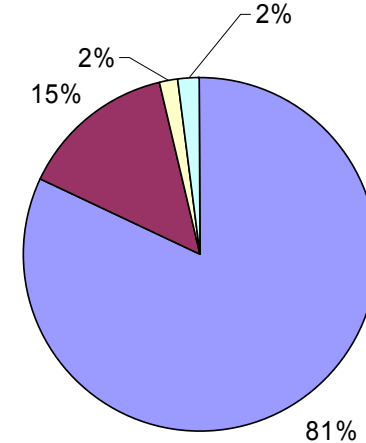

Lower Talus – Artefact Analysis

Lower Talus - Artefact weathering condition

■ fresh ■ abraded ■ weathered

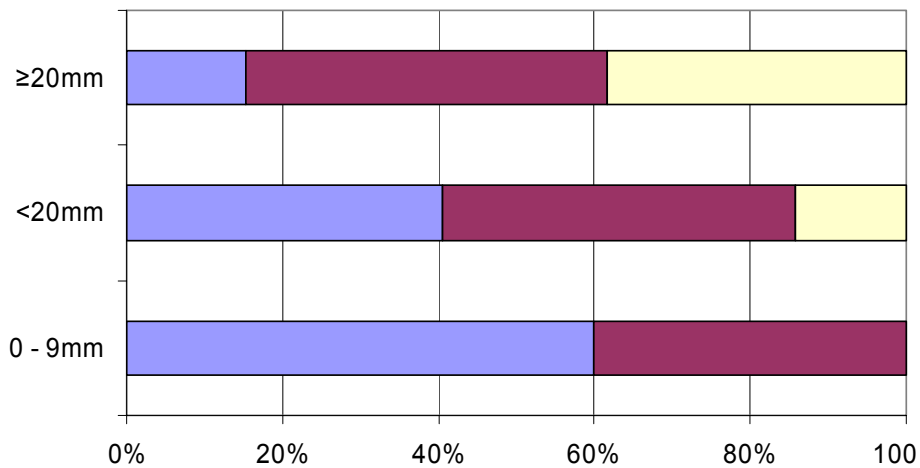

Lower Talus - Artefact size and distribution

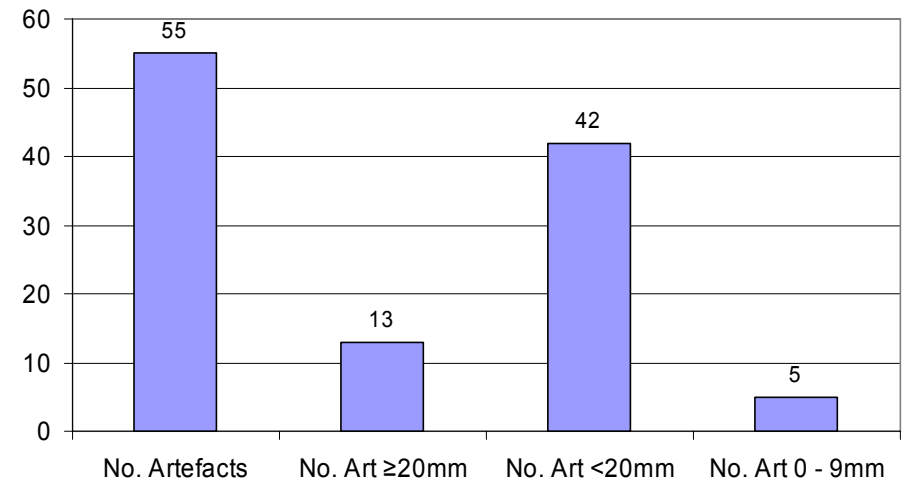

N.C. Total - Artefact distribution ≥ 20 mm and < 20 mm

≥ 20 mm 10-19mm < 10 mm

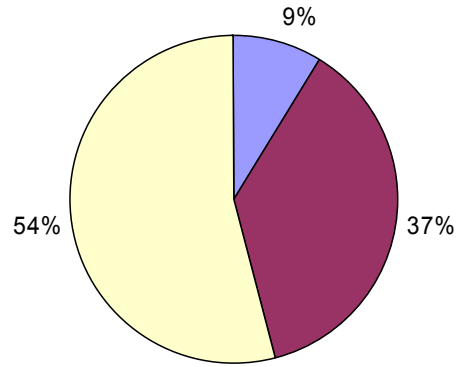

N.C. Total - Artefact distribution

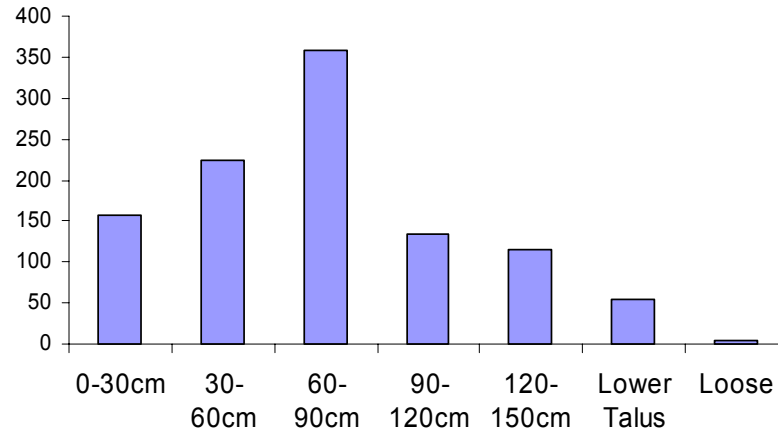

N.C. Total - Raw material distribution

Quartz Chert Quartzite

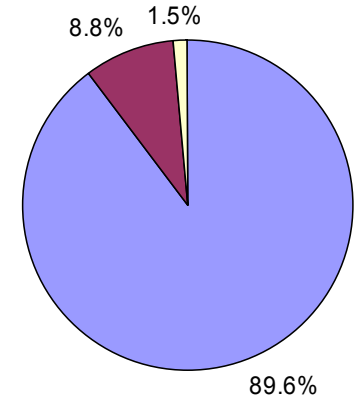

Name Chamber Total – Artefact Analysis

N.C. Total - Artefact weathering condition

fresh abraded weathered

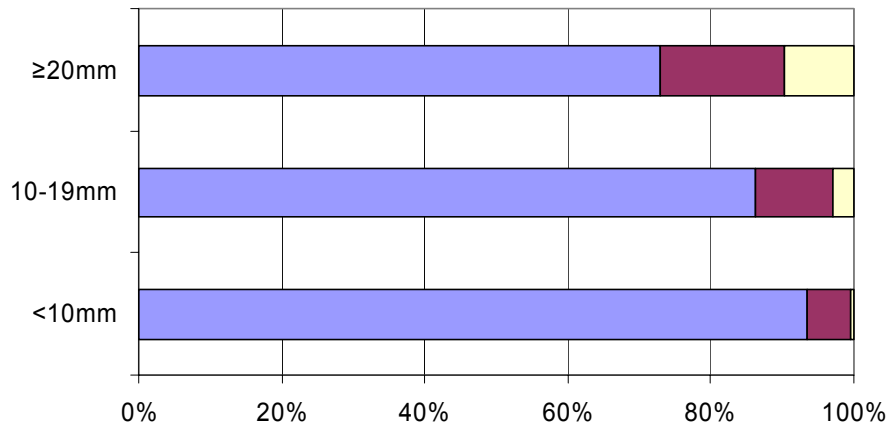

N.C. Total - Artefact size and distribution

0-30cm 30-60cm 60-90cm 90-120cm
120-150cm Lower Talus Loose

