

A New Dynamical Test Bench for Multi-Axial Loading of Angle Grinders

Matthias Dörr, Joscha Mertens, Thomas Gwosch and Sven Matthiesen

KIT SCIENTIFIC WORKING PAPERS 159

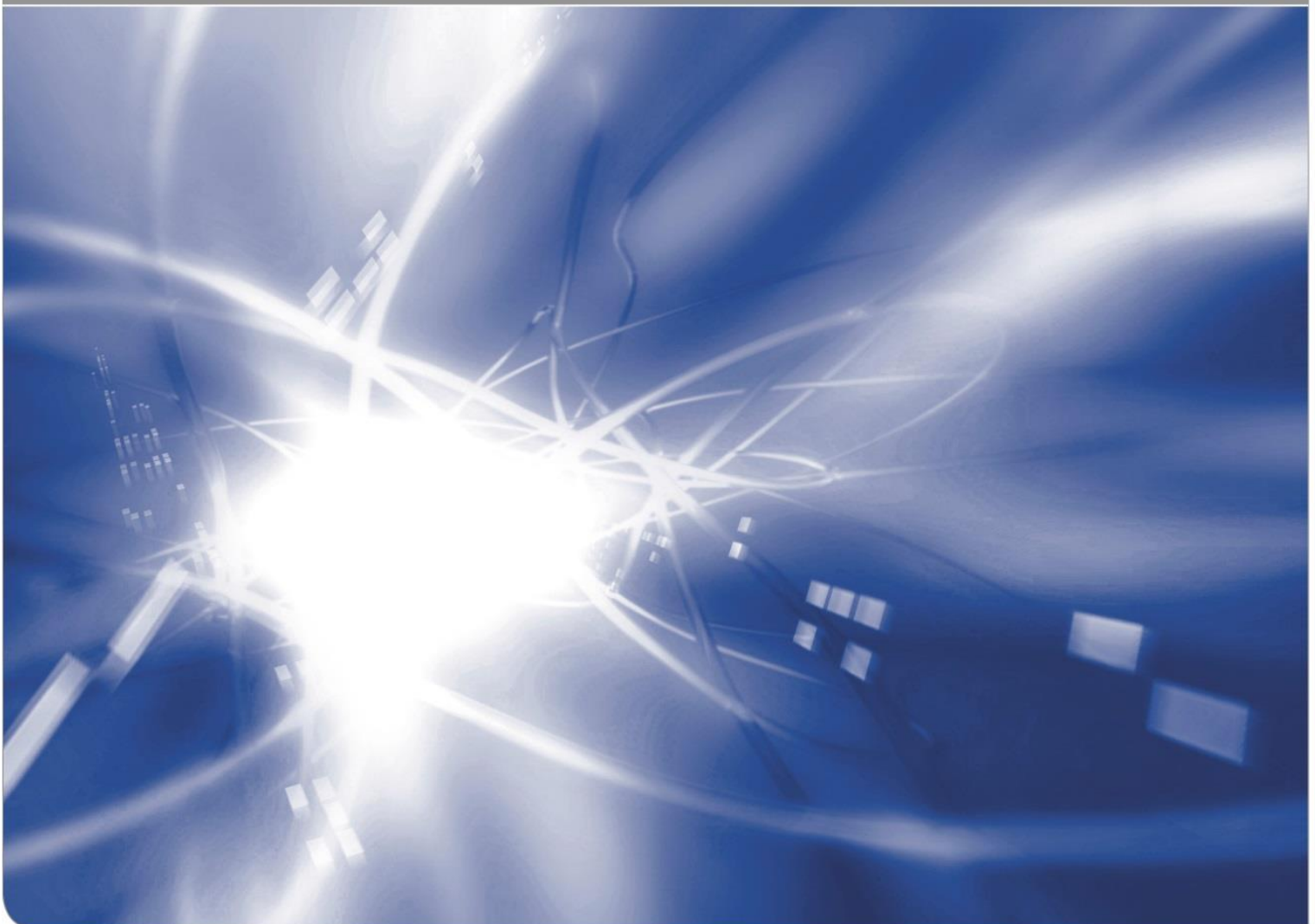

facultative
Institute of Product Engineering
Kaiserstr, 10
76131 Karlsruhe
www.ipek.kit.edu

Impressum

Karlsruher Institut für Technologie (KIT)
www.kit.edu



This document is licensed under the Creative Commons Attribution – Share Alike 4.0 International License (CC BY-SA 4.0): <https://creativecommons.org/licenses/by-sa/4.0/deed.en>

2021

ISSN: 2194-1629

A New Dynamical Test Bench for Multi-Axial Loading of Angle Grinders

Matthias Dörr, Joscha Mertens, Thomas Gwosch and Sven Matthiesen

IPEK - Institute of Product Engineering at Karlsruhe Institute of Technology (KIT)

Abstract

Automated testing with test benches plays a major role in the development of power tools such as angle grinders. Previous test benches for testing the drive train of an angle grinder replace the load from grinding a workpiece by dynamometer or servo motor in rotary direction and by linear motors in radial and axial direction. These can only apply forces up to 10 Hz and thus no speed-dependent force components. The aim of this paper is to develop a test bench for dynamic mechanical loading of the drive train of an angle grinder in the rotational, radial and axial axes up to 200 Hz, which corresponds to the maximum speed of an angle grinder. For this purpose, the modelling of the force application on the test bench and the resulting mechanical design is presented. In addition, the generation of test cases from measurement data of manual tests and the verification of the test bench are presented. Subsequently, a case study is presented to investigate the load pattern on the test bench with multi-axial load compared to pure torque loading on the same test bench and manual tests. It can be seen that the load pattern of the multi-axial load is qualitatively similar that of the load pattern from the manual test. Through using the developed test bench, it will be possible to investigate load patterns as well as wear or vibration of the drive train of an angle grinder.

1. Introduction

In product development and research, physical testing of prototypes and products is of great importance. Physical Testing is used, for example, in the validation and approval of products in the product development process and in the parameterisation and verification of models and simulations. It is also used to generate knowledge and findings in both product development and research. In the case of handheld power tools, manual tests are carried out by users and automated tests are carried out with test benches.

Manual tests can be used to load a handheld power tool under realistic environmental conditions in a realistic manner. Still, manual tests possess the drawback that the test conditions cannot be kept constant with respect to the influence of a user, for example. Due to the realistic loading, manual tests are suitable for tests late in the development process, when the power tool has to be validated and approved.

Automated tests using test benches enable reproducible tests with defined test conditions that stay constant. Compared to manual tests, the reproducibility of the tests makes it easier to analyse the behaviour of the system properties and thus to gain knowledge about the system. Test benches are divided into production test benches (end-of-line test benches), which are used for quality assurance in production, and development test benches, which are used for general testing in design [1].

In the field of angle grinders, development test benches are used to investigate various aspects of the overall machine. Test benches may be used for the following reasons: climate and height simulation [2], simulating kickback [3] and investigating noise emissions [4]. Test benches are also used to investigate tools, such as grinding wheels, where angle grinders are clamped on and moved around by various servo axes to process a workpiece [5, 6].

Investigating the durability of a drive train with real workpieces over the lifetime of an angle grinder requires a lot of material and time for retooling. Therefore, automated tests in the industrial environment that investigate the durability of a drive train are mainly carried out on test benches with dynamometers. The output shaft of the angle grinder is loaded on a dynamometer for a fixed number of hours under various constant loads. It is important to note that through testing with dynamometers the dynamic torque profiles as well as axial and radial forces that occur during the operation of an angle grinder are not considered. [7]

For this reason, IPEK has developed a test bench for more realistic testing of angle grinder drive trains. For this purpose, a dynamic torque profile is generated as load for the angle grinder by a servo motor. In addition, the radial and axial forces acting on the drive train are represented by three linear actuators. With this test bench it is possible to apply forces up to a dynamic of 10 Hz. The forces are applied by creating shaft displacement of the drive train through using linear actors. Therefore the displacements must be known for the test in order to apply equivalent forces. [8]

Since the forces and torques acting on the drive train depend strongly on the 1st order of speed [9], a test bench should apply dynamic forces and torques over the maximum idle speed of an angle grinder (10500 rpm). In order to include all phenomena within the first order of the rotational speed, the limit for applying the load is set at 200 Hz. Therefore, the aim of this paper is to present and verify a test bench that can apply dynamic forces and torque up to 200 Hz. In addition, a case study is presented to investigate the load pattern on the test bench with multi-axial load compared to pure torque loading on the same test bench and manual tests.

2. Development and Design of the Test Bench

This chapter describes the modelling of the force application on the test bench and the resulting mechanical design. The specification of the test bench is then summarised. In addition, the generation of test cases from measurement data of manual tests and the verification of the test bench are presented.

Modelling the force application on the test bench

To apply a realistic load on the drive train of an angle grinder, an abstraction of the real load is necessary. The shaft of the drive train is loaded by the torque, axial force and a radial force which are transmitted to the drive train via the tool during the working process of the angle grinder. The torque and the forces are applied on the shaft of the angle grinder via a double-row roller bearings using different actuators up to a frequency of 200 Hz:

- The torque is applied to the drive train by a servo motor.
- The axial forces up to 200 Hz are applied by a vibration exciter (shaker).
- The radial forces are applied by a superposition of forces from three different actuators: a shaker as well as via two linear drives (stepper).

The concept for force application and superposition of the radial force is shown in figure 1.

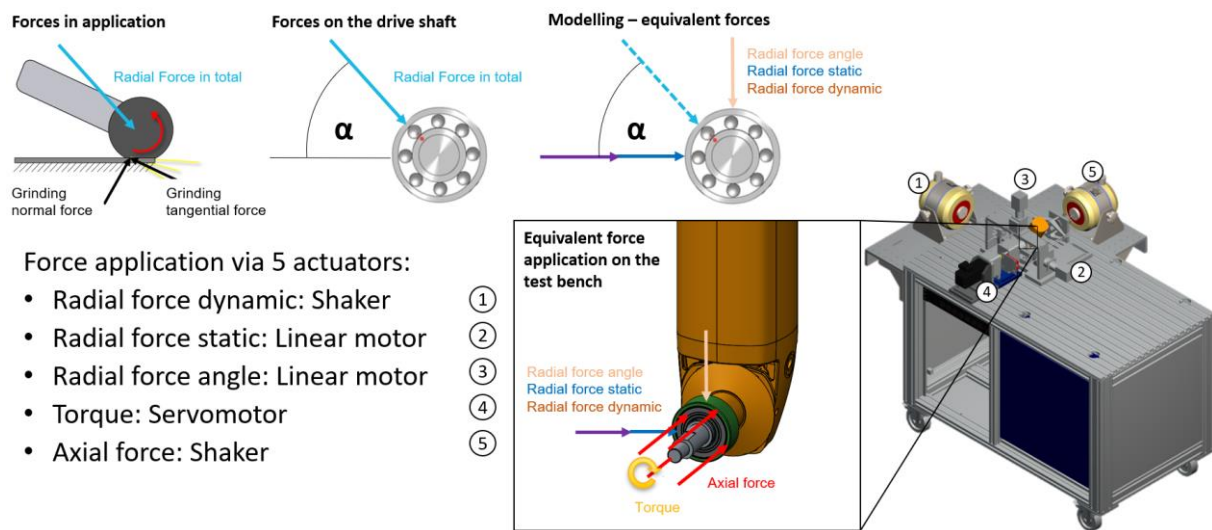

Figure 1: Concept for force application and superposition of the radial force on the test bench

For the superposition of the radial forces the radial shaker applies the dynamic forces from 10 to 200 Hz, while two orthogonally arranged linear motors apply the forces up to 10 Hz. For the magnitude of the force, the static component is provided by both linear motors and the dynamic component is provided by the shaker. Through superposition, the magnitude and the angle of the radial force is equivalently applied to the angle grinder by the shaker and the two linear motors. By superposition of the linear motors, the angle α of the force application to the bearing and thus to the drive shaft is set. Through appropriate modelling, they determine the angle α of the force application on the bearing and thus on the drive shaft. Since the angle at which the radial force acts on the shaft depends only on the active user behaviour, which is limited to 10 Hz, the angle can be adjusted by the linear motors.

Mechanical design of the test bench

The design of the test bench for the application of dynamic forces on a fast-rotating drive train had to take several aspects into account:

- Decoupling of forces from different directions
- Separation of dynamic and static force application
- Reduction of constraining forces due to the rotating drive train
- Optimisation of natural frequencies

Since all forces are transmitted via the same angular contact ball bearing (1) on the shaft of the angle grinder (2), it is necessary to decouple the axial and radial forces. These forces, coming from different directions, are decoupled from each other by bending rods (3). The bending rods (3) have a high rigidity in the axial direction in order to transmit the forces as rigidly as possible. At the same time, they possess a low bending rigidity in order to compensate for the radial movements. As a result, the radially acting forces have no appreciable influence on the force sensors and the measurement results. To prevent the bending rods (3) from folding, they are only subjected to tensile loads on both sides via disc springs (4). The realized concept for decoupling of forces from different directions is shown on in figure 2.

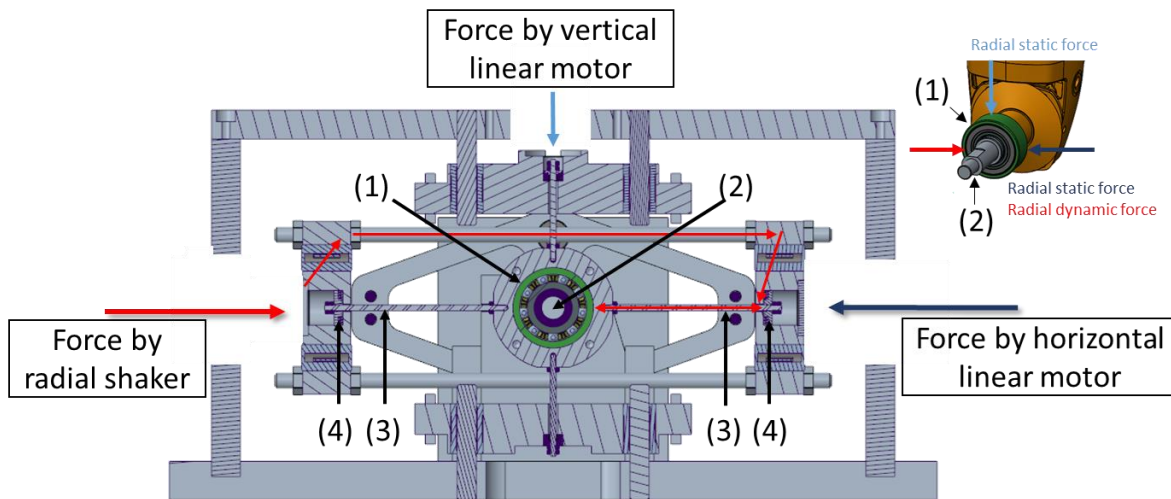

Figure 2: Realized concept for decoupling of forces from different directions

In addition, dynamic forces from the shaker and static forces from the linear motor in the horizontal direction need to be decoupled from each other by dynamically tuning the system. Since the shakers themselves can compensate for static displacements due to their low stiffness (5), the shaker can apply dynamic forces and hence is decoupled from static forces. By inserting a rubber buffer (6) with low stiffness (61 N/mm) between the linear motors and the drive train, the linear motors themselves can apply static forces and are decoupled from dynamic forces at the same time. The realized concept of the force decoupling in horizontal direction is shown in the following figure 3.

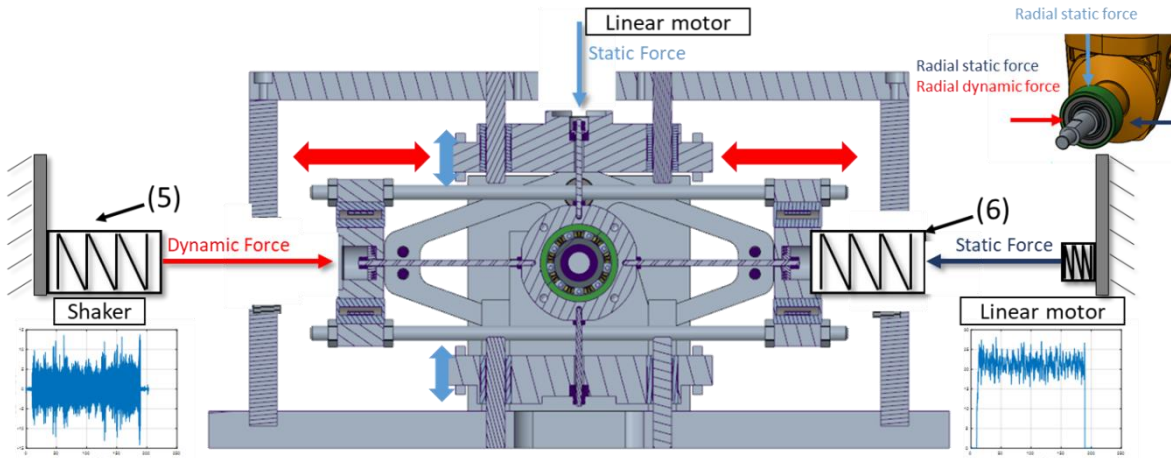

Figure 3: Realized concept for decoupling of static and dynamic forces in horizontal direction

The consideration of natural frequency and constraint forces leads to a trade-off in stiffness along the force flow between shaker and angular contact ball bearing. A low stiffness leads to low constraint forces but a low natural frequency. A high stiffness leads to high constraint forces and high natural frequencies. Therefore, the test bench should be adjusted to the angle grinder under test so that the critical speed or natural frequency remains below the idle speed. In this way, the test bench runs supercritical in the idle phase and subcritical in the application phase where the speed is significantly lower. In this way, the amplitude of the constraining forces in idle operation can be reduced to less than 2 N.

The decoupling of the radial and axial forces of the rotational load by the torque is done by a metal bellows coupling. Due to its low stiffness, this coupling can compensate the axial and radial displacement with minimal constraining forces and still enable a stiff transmission of the load in a rotational way. The realized test bench and its main components are shown in figure 4.

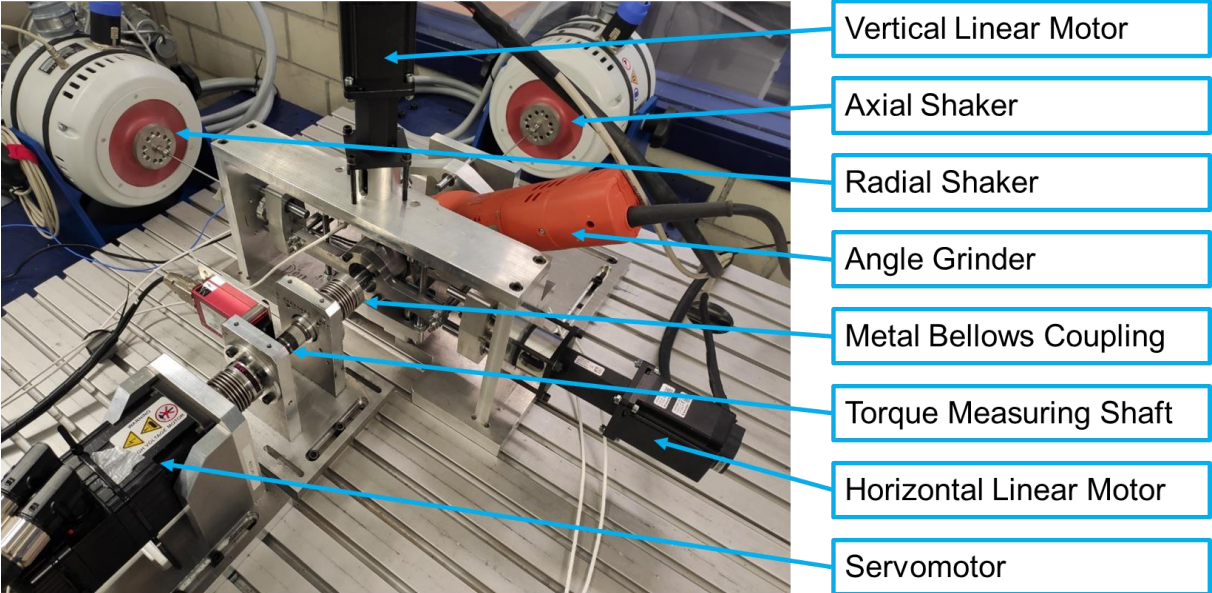

Figure 4: Realized test bench for multi- axial loading of angle grinders

Specification of the test bench

A strain gauge-based torque measuring shaft is used to measure the torque. Four strain gauge-based force sensors are used on the test bench to measure the forces in four directions. The position of the force sensors is shown in figure 5. The assembly of the torque measuring shaft is marked in yellow.

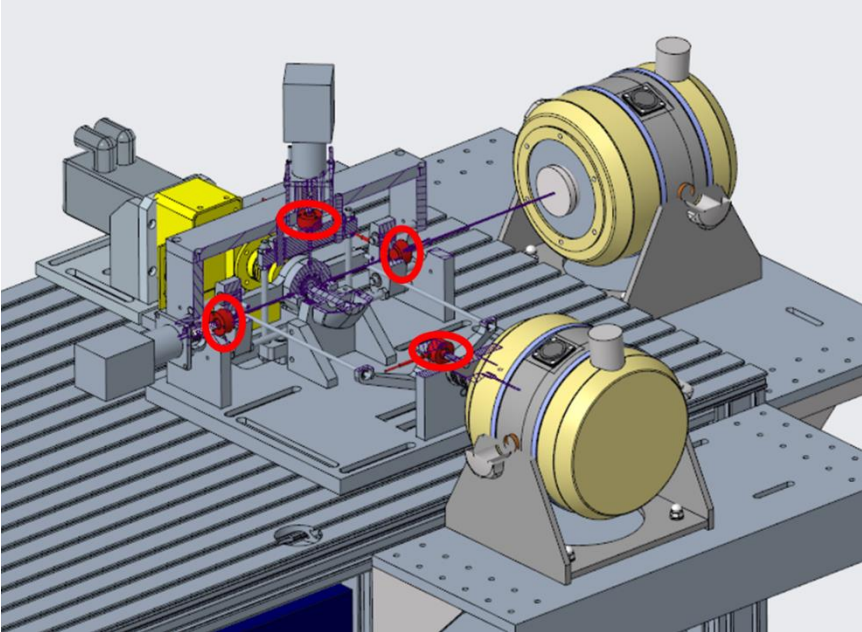

Figure 5: Positioning of the four force sensors (force sensors are circled in red, torque measuring shaft is marked yellow)

The following specification for the test bench results from the integrated sensors and actuators as well as the design implementation

Table 1: Specification of the test bench

Default frequency of a test case	200 Hz
Sampling frequency measuring system	20000 Hz
Rated speed servo motor	6200 rpm
Rated torque servo motor	1.4 Nm
Maximal thrust linearmotor	1000 N
Maximal speed linear motor at maximal thrust force	25 mm/s
Nominal force shaker (sine/noise)	400 N/ 311 N
Max. acceleration shaker (sine/noise)	100 g / 50 g
Accuracy of the torque measuring shaft	<0.25%
Accuracy of the force sensors	<0.25%

Generation of test cases for the test bench

The actuators on the test bench require the following setpoints:

- The two shakers require a current as setpoint
- The two linear motors require a displacement as setpoint
- The servo motor requires a torque as setpoint

The available input to the test bench is measured during manual testing is often different from the setpoints for the actuators. Available inputs for example are the radial and axial forces on the drive shaft [10] and the electrical power consumption of the angle grinder [8]. Therefore, a process is presented for converting the measured variables from manual tests into the setpoints for the actuators by calibrating and measuring the test bench. With the process, the test bench will be open-loop controlled instead of closed-loop controlled, which improves the dynamic performance. The process is shown in figure 6.

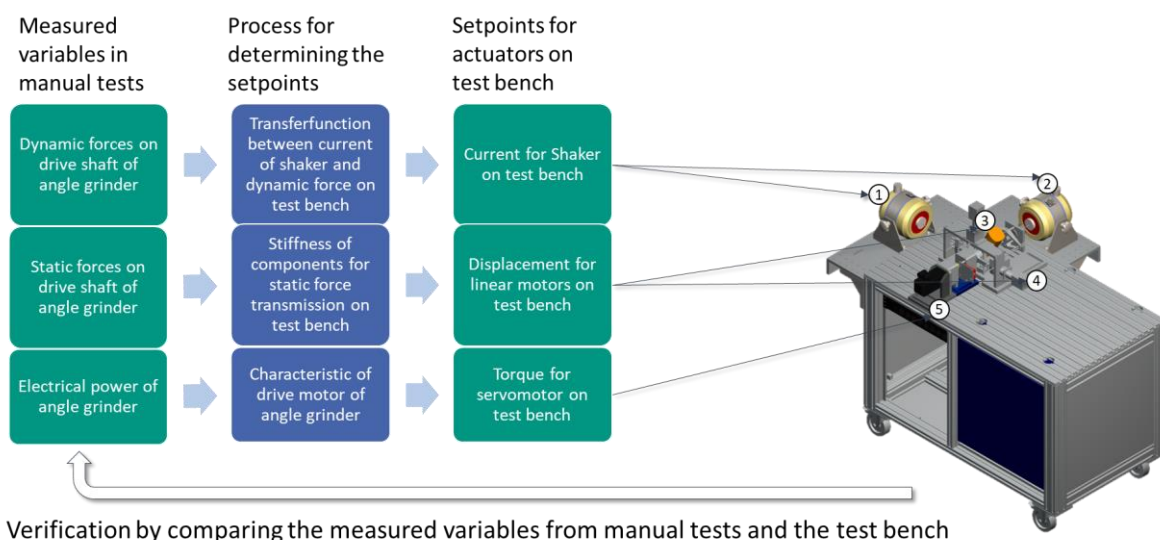

Figure 6: Process for the conversion of measured variables in manual tests into specified variables on the test bench

The stiffness of the components of the test bench can be determined experimentally as a linear relationship between static forces and the path of the linear motor. The motor characteristic of the angle grinder can also be determined experimentally as a linear relationship between the electrical power of the angle grinder and the torque of the servomotor. For the setpoint current of the shakers, a transfer function can be determined. This transfer function represents the frequency-dependent relationship between the dynamic forces and current due to the dynamic properties of the shaker.

3. Verification of the Test Bench

The verification is carried out by comparing the measured variables on the test bench with the measured variables from manual tests. The measured variables from manual tests were used to determine the setpoints for the test bench. This is shown in figure 6. A cut-off phase with a cut-off wheel including short idle phases at the start and the end is applied and compared. The comparison of setpoint and measured values for the torque profile and the comparison of measured variables from manual tests and the measured variables on the test bench for the speed profile is shown in figure 7.

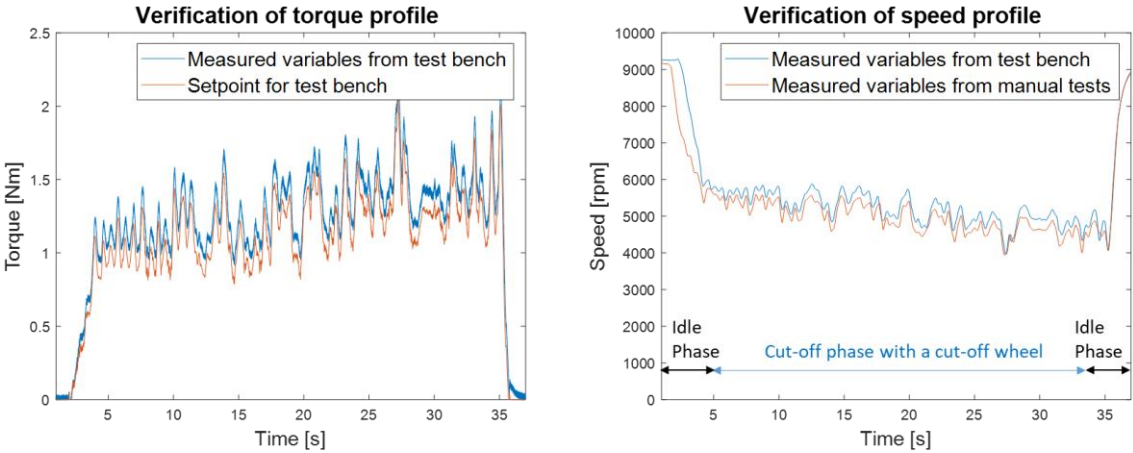
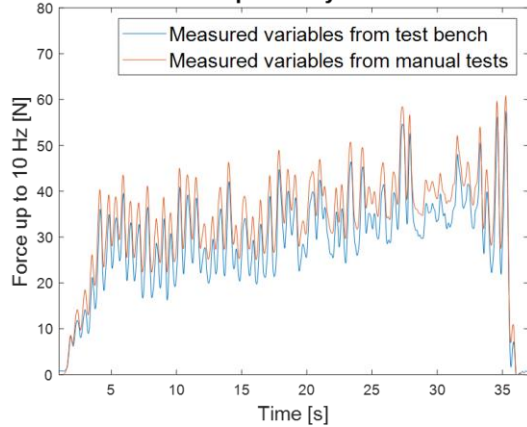

Figure 7: Comparison of setpoint and measured values for the torque profile and comparison of measured variables from manual tests and from the test bench for the speed profile

Figure 7 shows idle phases at a speed of over 9000 rpm and a cut-off phase where the speed is reduced to below 6000 rpm. For the torque a good correlation is achieved ($R^2 = 0.99$; Mean Absolute Error = -0.12 Nm, R^2). The constant oscillation for torque at a frequency of 100 Hz is result of the pulsation of the electric motor of the angle grinder at the double mains frequency. For the torque a medium correlation is achieved ($R^2 = 0.79$; Mean Absolute Error = 327 rpm). This is due to the speed-dependent friction on the test bench, which is not present in the manual tests. Figure 8 shows the comparison of the applied forces for both linear motors.

Verification of force profile by vertical linear motor



Verification of force profile by horizontal linear motor

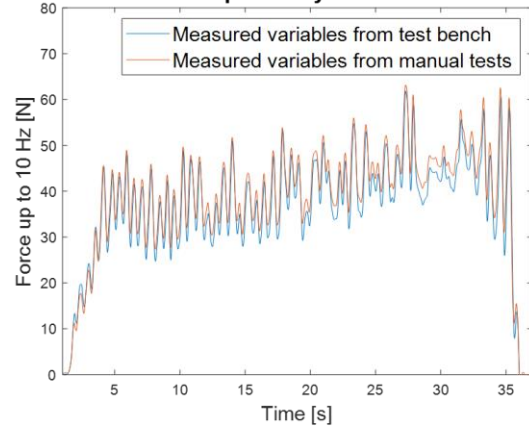
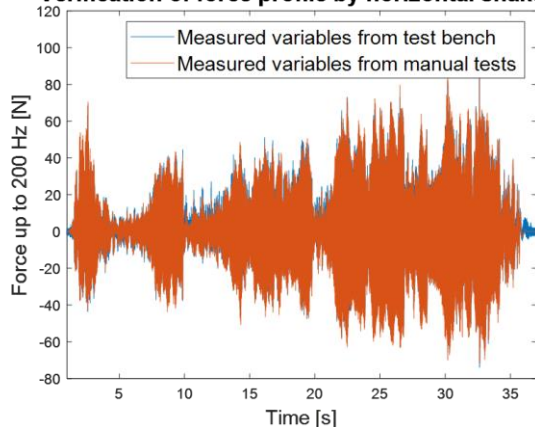

Figure 8: Comparison of measured variables from manual tests and from the test bench for force application of both linear motors

Again, a good correlation can be seen here for the horizontal linear motor ($R^2 = 0.98$; Mean Absolute Error = 1.9 N). The static forces in the vertical direction for adjusting the angle are slightly increased on the test bench ($R^2 = 0.98$; Mean Absolute Error = 4.3 N). Figure 9 shows the comparison of the applied forces for both shakers.

Verification of force profile by horizontal shaker



Verification of force profile by axial shaker

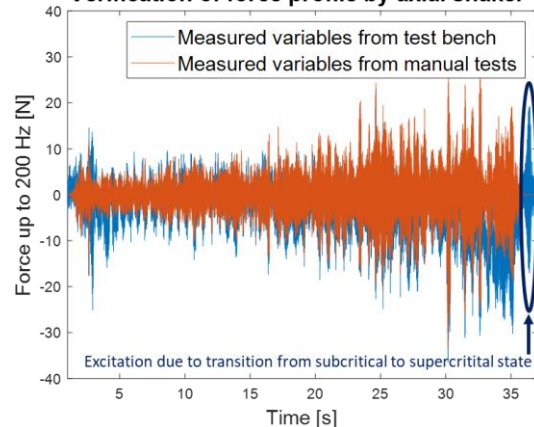

Figure 9: Comparison of measured variables from manual tests and from the test bench for force application of both shakers

In the radial direction a good correlation of the dynamic forces up to 200 Hz is seen ($R^2 = 0.91$; Mean Absolute Error = -1.3 N). For the axial shaker a mean correlation can also be seen ($R^2 = 0.57$; Mean Absolute Error = 2.3 N), which is caused by constraining forces, which have an influence especially with small nominal signal values during the application cutting of steel plates. In addition, the change from the supercritical state to the subcritical state can be seen during the transition from idle phase to load phase.

4. Case Study: Investigation of the Load Pattern on the Test Bench with Multi-Axial Load

The aim of the case study is to investigate whether a comparable contact pattern can be generated with automated tests on the test bench compared to manual tests and what influence a multi-axial load has compared to pure torque loading. For this purpose, a total of seven angle grinders were tested in automated tests on the test bench and in manual tests. The cutting with cut-off wheels was tested, since here the comparatively high static and dynamic radial forces are present compared to other applications [11]. The tests are listed in the following table.

Table 2: Experimental design for case study

Tests	Number and duration of tests
Pure torque loading on the test bench	2x 50 h
Multi-axial loading on the test bench	2x 50 h
Manual tests by user	3x 50 h

The automated tests on the test bench were carried out for a duration of 50 h without switching off the angle grinder. In the continuous run, after a load profile of a cut-off test, a change to no-load operation was made to prevent the equipment from overheating. This results in a distribution of 60% load and 40% no-load. The manual tests were also carried out over a total duration of 50 h, whereby the application cutting steel with a cut-off wheel was specified. However, the devices were switched off between experimental periods.

During a continuous run, a constant temperature of approx. 60 °C was present at the gear housing after a short run-in period. This corresponds to the temperature measured in the manual tests. As a result, the contact pattern was analysed for the thrust and traction flanks of the ring gear. The thrust flank and the traction flank of the ring gear after a 50 h endurance run with pure torque load and multi-axial loading and from 50 h manual tests can be seen in the following figure 10.

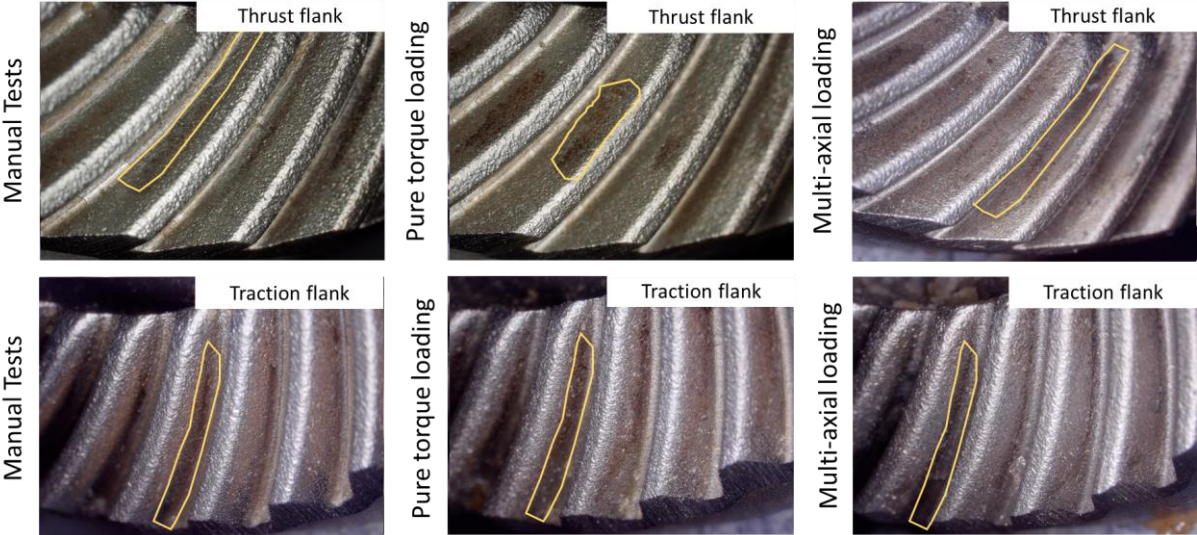

Figure 10: Thrust flank and the traction flank of the ring gear after 50 h endurance tests (load pattern is marked yellow)

The analysis of the contact pattern revealed that the contact pattern of the thrust flank under pure torque loading is significantly narrower than that under multi-axial loading, while the contact pattern under the tension flank is the same for both types of loading. These results were reproduced in both endurance tests with pure torque loading as well as with multi-axial loading.

The different load-carrying pattern corresponds to the expected result. The tension flank is in contact mainly during no-load operation. Therefore, the same load-carrying pattern on the tension flank can be explained by the fact that the no-load operation is identical between the applications under pure torque loading and under multi-axial loading. The thrust flank is mainly in tooth contact in the application, since the speed is pressed here by the counter-torque of the servomotor. The wider contact pattern on the thrust flank can be attributed to the axial forces during multi-axial loading. This enables displacement along the tooth contact due to the low stiffness of the fixed-loose bearing of the angle grinder in the axial direction.

The same contact pattern occurred in all three angle grinders from the manual tests. This load-carrying pattern corresponds to the load-carrying pattern from the test bench with multi-axial loading. As shown in figure 10 the load-carrying pattern at the relevant thrust flank in the test bench with multi-axial loading differs from the narrower load-carrying pattern in the test bench with pure torque loading. It should therefore be emphasized that only the test bench with multi-axial excitation is suitable for generating realistic load patterns that are comparable with manual tests.

5. Discussion & Conclusion

The verification was carried out by comparing the torque, speed and force profiles of the setpoints obtained from manual tests with the measured variables on the test bench. It was shown that the concepts for superimposing the force and the process for converting the measured variables from the manual tests into target variables can be applied. The limit up to 200 Hz was investigated. Depending on the dynamic tuning, the natural frequency can be set above or below 200 Hz. In the experiments it proved to be useful to set the natural frequency between idle and load phase to reduce the constraint forces from the drivetrain that resulted from the stiffness of the system.

In the case study it was shown that the load patterns from the bench with multi-axial loading were qualitatively similar to load patterns from the manual tests. This is also in line with the results from IGF project 18196 N [12]. It has to be investigated whether comparable vibrations of the drive train and wear can be generated on the test bench.

The test bench provides a way to apply a dynamic multi-axial load on the drive train of an angle grinder. With this test bench it is possible to investigate load patterns of the gearbox of an angle grinder's drive train.

Acknowledgments

Parts of the mechanical structure of the test bench were developed as a part of a bachelor thesis at the IPEK - Institute of Product Engineering at Karlsruhe Institute of Technology (KIT). [13]

The research project 19881 N of the research association Forschungsgemeinschaft Werkzeuge und Werkstoffe e. V. - FGW, Papenberger Straße 49, 42859 Remscheid, Germany, was funded through the German Federation of Industrial Research Associations (AiF) as part of the Industrial Collective Research program (IGF) by the German Federal Ministry of Economic Affairs and Energy according to a resolution passed at the German Federal Parliament.

References

- [1] M. Paulweber and K. Lebert, *Mess- und Prüfstandstechnik: Antriebsstrangentwicklung, Hybridisierung, Elektrifizierung*. Wiesbaden: Springer Vieweg, 2014.
- [2] A. Martel, F. Scholl, D. Weierter, and M. Kettner, "Development of a Climate and Altitude Simulation Test Bench for Handheld Power Tools," in *SAE/JSAE Small Engine Technology Conference*, Düsseldorf, Germany, 2018, n. p.
- [3] G. Fleury, "Numerical Model to Predict Kickback for Angle Grinders," in *The 11th European LS-DYNA Conference*, Salzburg, Austria, 2017, n. p.
- [4] H. Gärtner, "Einflussgrößen auf die Geräuschemission von handgeführten Schleifmaschinen unter Berücksichtigung des Abtrags- und Verschleißverhaltens," in *Berichte aus dem Institut für Werkzeugmaschinen / Konstruktion und Fertigung*, Universität Stuttgart, Institut für Werkzeugmaschinen, Ed., Tübingen: MVK, Medien-Verl. Köhler, 2004.
- [5] N. Ortega, V. Martynenko, D. Perez, D. Martinez Kraemer, L. N. López de Lacalle, and E. Ukar, "Abrasive Disc Performance in Dry-Cutting of Medium-Carbon Steel," *Metals*, vol. 10, no. 4, p. 538, 2020.
- [6] Räbel Steuerungstechnik Datenverarbeitung, "Schleifscheibenprüfstand," <http://www.ecolight.de/pruefstandstechnik/Schleifscheiben/Schleifscheiben.html> (accessed: Feb. 19 2021).
- [7] T. Gwosch, "Antriebsstrangprüfstände zur Ableitung von Konstruktionszielgrößen in der Produktentwicklung handgehaltener Power-Tools," in *Forschungsberichte des IPEK – Institut für Produktentwicklung*, A. Albers and S. Matthiesen, Eds., vol. 117, Karlsruhe, 2019.
- [8] S. Matthiesen, T. Gwosch, S. Mangold, P. Dueltgen, C. Pelshenke, and H.-J. Gittel, "Realitätsnahe Komponententests zur Unterstützung der Produktentwicklung bei der Validierung von Power-Tools," *Die Konstruktion*, 7/8-2017, pp. 76–81, 2017.
- [9] S. Matthiesen, T. Gwosch, and T. Bruchmueller, "Experimentelle Identifikation von Schwingungsursachen in Antriebssträngen von Power-Tools," in *VDI Fachtagung Schwingungen 2017: Berechnung, Überwachung, Anwendung*, Nürtingen, Germany, 2017, pp. 311–322.

- [10] G. Phan, S. Kana, and D. Campolo, "Instrumentation of a grinding tool for capturing dynamic interactions with the workpiece," in *2017 IEEE International Conference on Cybernetics and Intelligent Systems (CIS) and IEEE Conference on Robotics, Automation and Mechatronics (RAM)*, Ningbo, China, 2017, pp. 551–555.
- [11] M. Dörr *et al.*, "Experimental Abrasive Contact Analysis – Dynamic Forces between Grinding Discs and Steel for common Angle Grinder Applications," in *11th TOOLING 2019 conference & exhibition*, Aachen, Germany, 2019, n. p.
- [12] S. Matthiesen, T. Gwosch, and H.-J. Gittel, "Schlussbericht zu IGF-Vorhaben Nr. 18196N – Entwicklung einer beanspruchungsidetischen Prüftechnik für Elektrowerkzeug-Komponenten," FGW – Forschungsgemeinschaft Werkzeuge und Werkstoffe, Ed., Remscheid, Germany, 2017.
- [13] J. Mertens, "Entwicklung und Konstruktion eines dynamischen Prüfstandes für Winkelschleifer," Bachelorthesis, IPEK - Institut für Produktentwicklung, Karlsruher Institut für Technologie (KIT), Karlsruhe, 2019.

KIT Scientific Working Papers
ISSN 2194-1629

www.kit.edu