

Optimization of frequency discretization for diagnostic information at diagnostics of technical objects

A V Asadchiy¹, A I Soldatov^{2,3}, A A Soldatov^{4,5} and O H Kim⁶

¹Graduate student, National research Tomsk polytechnic university, Tomsk, Russia

²Professor, National research Tomsk polytechnic university, Tomsk, Russia

³Professor, Tomsk state University of control systems and Radioelectronics, Tomsk, Russia

⁴Associate professor, National research Tomsk polytechnic university, Tomsk, Russia

⁵Associate professor, Tomsk state University of control systems and Radioelectronics, Tomsk, Russia

⁶Direktor, Honbin ltd, Tomsk, Russia

E-mail: asadchiav118@gmail.com

Abstract. The block diagram of the monitoring device is presented. The operation principle of the monitoring device is described. The main units affecting the quality of the monitored signal reconstruction are shown. The analysis of the differentiating device and the voltage-controlled generator is carried out. The main characteristics of the differentiating device and the voltage-controlled oscillator are given and the quality of signal reconstruction is evaluated when their parameters change. The requirements for choosing the optimal value of the derivative time constant and the frequency range of the voltage-controlled generator are specified. A calculation example of the required RAM for recording and reconstruction of the monitored signal is shown.

1. Introduction

When operating electrical equipment in various autonomous power supply systems, a special place is occupied by the possibility of fast and correct assessment of all received diagnostic information and making an operational decision on the results of this assessment. Diagnostic information allows to estimate the serviceability of the object at any time [1–8]. An important criterion of such assessments is completeness of monitoring of the tested object, which consists in informativity of witnessed electric parameters and the amount of diagnostic information.

As a rule, during operation of various voltage converters its electrical parameters are monitored: input and output voltage, input current and load current., The control of converter operation modes are based on the monitored parameters and diagnostic signals and information data are generated [9].

To date, there are a number of technical solutions [10] that allow to realize the possibility of voltage converter monitoring, but unfortunately these devices have some disadvantages: enter data items one by one, discontinuous monitoring, lack of detailed information on quantitative values of electrical parameters and failure.

Also, a very important feature in such information-measuring devices is the volume and lifetime of non-volatile memory. Non-volatile memory should store quantitative information about electrical parameters, but unfortunately, in case of multiple rewrites, the service life of the RAM is reduced.

You can extend the lifetime of RAM by using various compression and archiving methods. Methods of information compression are very widespread today [7], but they require definite software and algorithm solutions, as a result the time of electrical parameters processing is increased.



2. Task Setting

One of the most optimal solutions for monitoring electrical parameters and reduce the amount of RAM is to save data in RAM only when the monitored electrical parameter changes and thus, the amount of RAM will be used more efficiently without the use of data compression algorithms [11].

For the development of such devices, it is necessary to know its limit parameters, at which data is stored in RAM. Let's look at the block diagram of the proposed device (Figure 1) and its operating principle.

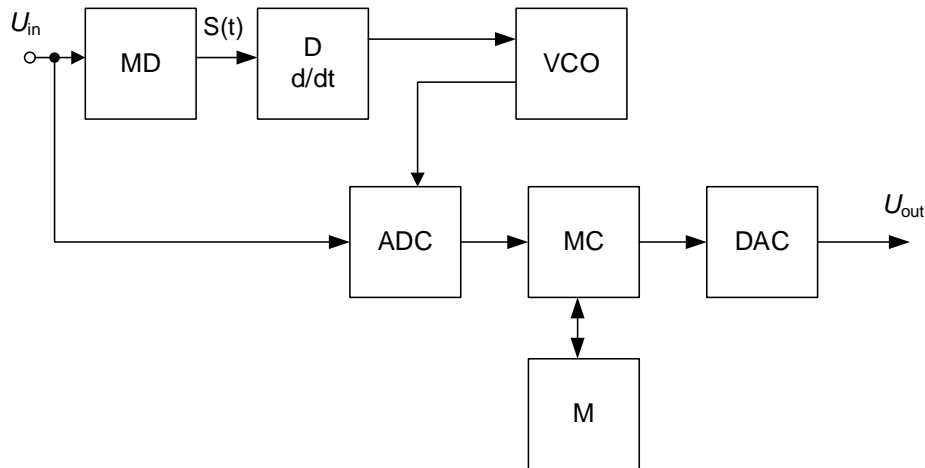

Figure 1. Scheme of control device

The device operates as follows: the test signal U_{ts} is supplied to the input of the matching device (MD) and the analog-to-digital Converter (ADC). The matching device converts the test signal to the level of the ADC and differentiator (D). The differentiator calculates a derivative of the test signal, which is supplied to a voltage controlled oscillator (VCO). VCO generates clock pulses for the analog-to-digital Converter. The ADC converts the test signal into digital form and transmits them to the microcontroller (MC). MC writes to RAM of the tested signal $S(t)$ at occurrence of malfunctions or various transients. By an external control command, the microcontroller extracts data from the memory and supplies it to a ADC. The digital-to-analog converter restores the test signal U_{out} .

On the basis of the obtained data in the form of tested signal, it is possible to carry out qualitative and quantitative assessment of transient process in case of failure, namely, to calculate transient rate, maximum and minimum voltage deviations.

The main units affecting the accuracy of recovery of the monitored signal are the differentiator and the voltage-controlled generator. These units contain parametric circuits that determine their characteristics. These are the time constant of the differentiator, the frequency range of the controlled voltage generator, the linearity of the characteristic, etc.

3. Evaluation of signal recovery quality in case of differentiator parameters change

The differentiator calculates the derivative of the test signal. The output signal of the differentiator $U_{out}(t)$ depends on the input signal $U_{in}(t)$:

$$U_{out}(t) = \tau \frac{dU_{in}}{dt},$$

where $\tau = RC$ is a time constant of the differentiator.

The differentiation parameters depend on the time constant τ and are determined by the capacitor C and the resistor R .

The operator format of gain-transfer characteristic of the differentiator is:

$$K(p) = \frac{p}{p + \frac{1}{\tau}}$$

where $p=j \omega$; j – imaginary unit, ω – frequency.

Amplitude-frequency characteristic of the differentiator is:

$$|K(\omega)| = \frac{\omega}{\sqrt{\left(\frac{1}{\omega}\right)^2 + \omega^2}} \tag{1}$$

Amplitude-frequency and gain-transfer characteristics are related by relations:

$$\begin{cases} \lim_{\omega \rightarrow 0} K(\omega) = \lim_{t \rightarrow \infty} h(t) \\ \lim_{\omega \rightarrow \infty} K(\omega) = \lim_{t \rightarrow 0} h(t) \end{cases} \tag{2}$$

The amplitude-frequency and gain-transfer characteristics for the differentiating circuit at different values of time constant, based on expressions 1 and 2, are shown in Figure 2.

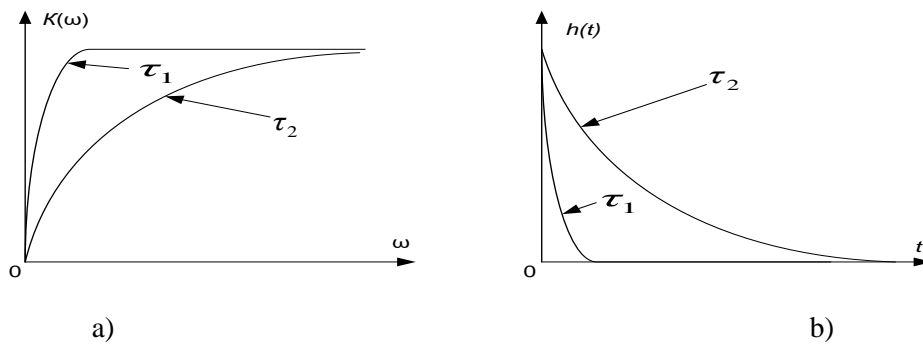

Figure 2. Amplitude-frequency (a) and transition characteristics (b) for the differentiating circuit at different values of time constant

The gain-transfer characteristic describes the output response of the differentiator to a single step signal. The gain-transfer characteristic analysis (Figure 2) shows that at different values of the time constant of the differentiator, the rate of derivative changes will be different. A long-time constant of the differentiator results in a slower change in the output signal.

Let us analyze the operation of the monitoring device by comparing the quality of signal recovery at two different values of the time constant of the differentiator. The estimation of the signal recovery error was carried out in the Ni Multisim 12 for $\tau_1 = 30 \mu s$ and $\tau_2 = 600 \mu s$. The test signal is an exponential pulse with an amplitude of 4.3 V with a rising edge tr.e. = 21.6 ms and pulse droop tp.d. = 2.0 ms. The results of simulation are shown in Figure 3a and Figure 3b. The error signal is shown in Figure 4, calculated according to the expression:

$$\Delta U_{out}(t) = U_{in}(t) - U_{out}(t)$$

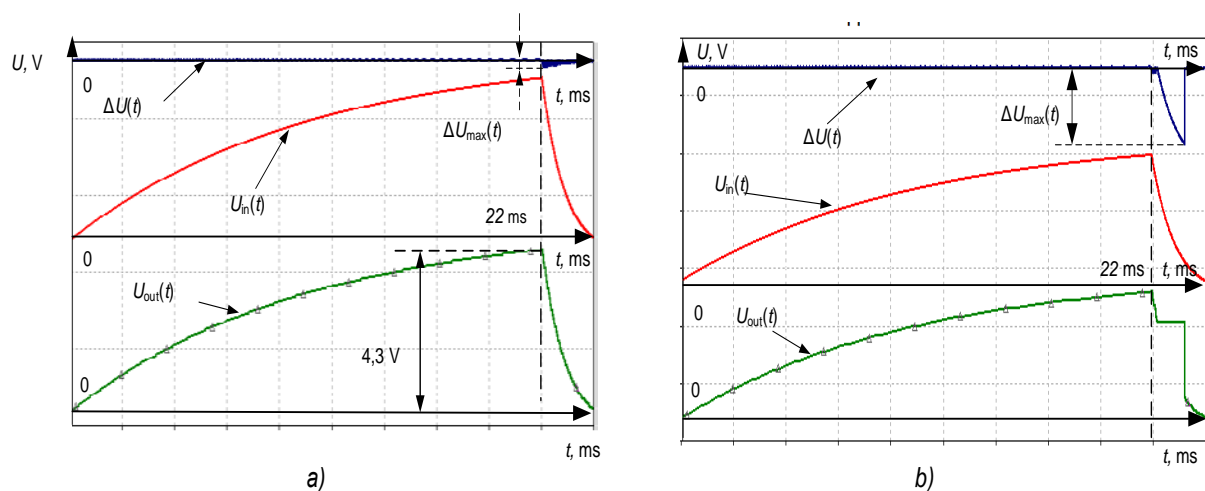

Figure 3. The waveform $U_{in}(t)$, $U_{out}(t)$ and $\Delta U_{out}(t)$ at a constant time of differentiator : a) at $\tau_1 = 30 \mu s$, b) $\tau_2 = 600 \mu s$

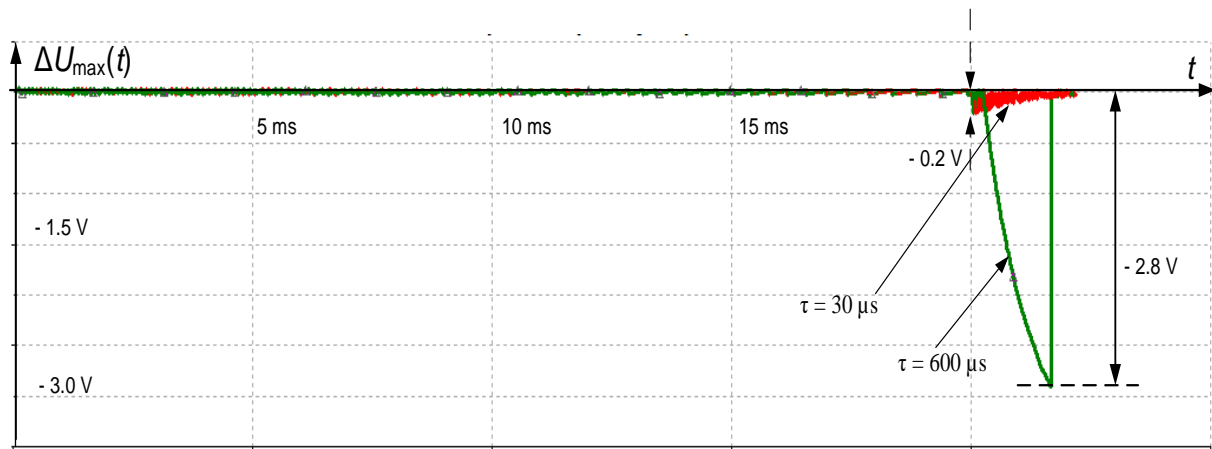

Figure 4. The waveform $\Delta U_{out}(t)$

The simulation results show that the smallest deviation of the recovered signal from the test signal will be at $\tau l = 30 \mu\text{s}$, and $\Delta U_{out}(t)$ equals 0.2 V (Figure 3a).

This is because, at a given chain time constant, the response of the differentiator to the input is much faster than at a value of $\tau l = 600 \mu\text{s}$. Thus, with a large output voltage of the differentiator, the voltage-controlled oscillator increases the pulse frequency, so the number of the test signal samples increases. This improves the quality of its recovery. The error of the recovered signal increases with increasing time constant differentiating. The maximum deviation of signal $\Delta U_{out}(t)$ was about 2.8 V if $\tau l = 600 \mu\text{s}$ (Figure 4).

4. Evaluation of signal recovery quality when voltage-controlled generator parameters change

The parameters of the voltage controlled oscillator affect the quality of the signal recovery. Voltage-controlled generators are widely used in radio communication equipment, in devices of phase automatic frequency adjustment, in devices of industrial automation, etc., its block diagram is presented in Figure 5.

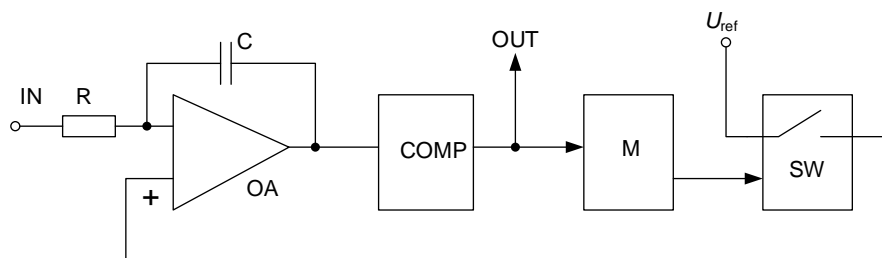

Figure 5. Block diagram of voltage-controlled generator

The circuit is based on a differential stage on an operating amplifier (OA). Switching frequency depends on capacitance C . Single-kick multivibrator (M) generates pulse on the comparator switching signal (COMP) with a normalized voltage-time curve. For this purpose, the switch (SW) and an additional reference voltage (U_{ref}) are used.

The main parameter under study is the electric-tuning range from the minimum value of f_{min} to the maximum value of f_{max} . The output characteristic of VCO is:

$$f_{out} = f_0 + S U_{inv}(t).$$

where f_0 – free frequency of oscillations, S – slope of VCO characteristics (V/Hz), $U_{inv}(t)$ – input voltage of VCO.

The results of modeling of VCO operation with a change in capacitance C and input voltage $U_{inv}(t)$, are presented in Table 1.

Table 1. Characteristic of VCO.

$U_{inv}(t)$, V	$C=470$ pF	$C=3.3$ nF	$C=50$ nF	$C=70$ nF
0	133	37.2	3.62	2.61
0.223	125	34.3	3.11	2.55
0.446	117.3	31.19	2.70	1.94
0.669	109.8	28.40	2.32	1.67
0.892	101.7	24.4	1.95	1.40
1.16	90.62	20.33	1.57	1.12
1.34	76.7	15.96	1.11	0.852
1.56	59.9	11.56	0.833	0.596
1.78	41.5	7.37	0.515	0.368
2.00	23.01	3.77	0.256	0.183
2.20	7.64	1.15	0.156	0.054

The characteristics of the voltage-controlled generator are presented in Figure 6.

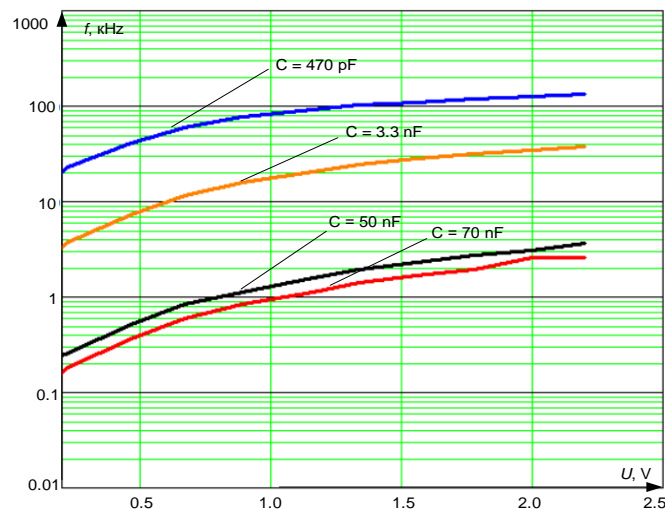

Figure 6. Output frequency ranges of the voltage-controlled generator at different capacitance C

From Figure 6 it can be seen that when the capacitance decreases, the electric-tuning range of the VCO increases.

We investigate the operation of the device for monitoring electrical parameters when changing the electric-tuning range of VCO (20–104) kHz and (0.17–2.8) kHz. The input signal is an exponential pulse, and the output is a reconstructed signal. The simulation results are shown in Figures 7a, 7b.

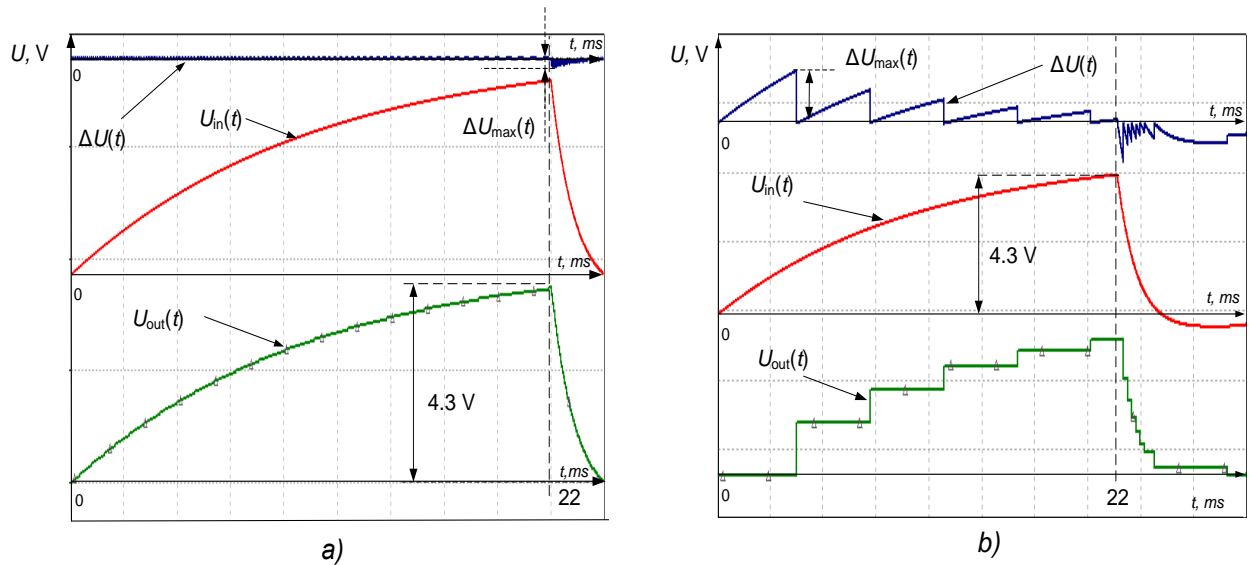

Figure 7. The waveform $U_{in}(t)$, $U_{out}(t)$ and an error signal $\Delta U_{out}(t)$ at various ranges of output frequency of VCO: a) at electric-tuning range (20–104) kHz; b) at electric-tuning range (0.17–2.8) kHz.

Error signal $\Delta U_{out}(t)$ is shown in Figure 8.

From Figures 7a, 7b it can be seen that the minimum signal error occurs when the VCO has the electric-tuning range from 20 kHz to 104 kHz. Maximum signal error $\Delta U_{out}(t)$ is 0.1 V (Figure 8 (red line)). This is due to the fact that the VCO produces a lot of clock pulses, which increases the number of samples of the input signal. The maximum error was 4.2 V in the range from 0.17 kHz to 2.8 kHz (Figure 8 (green line)).

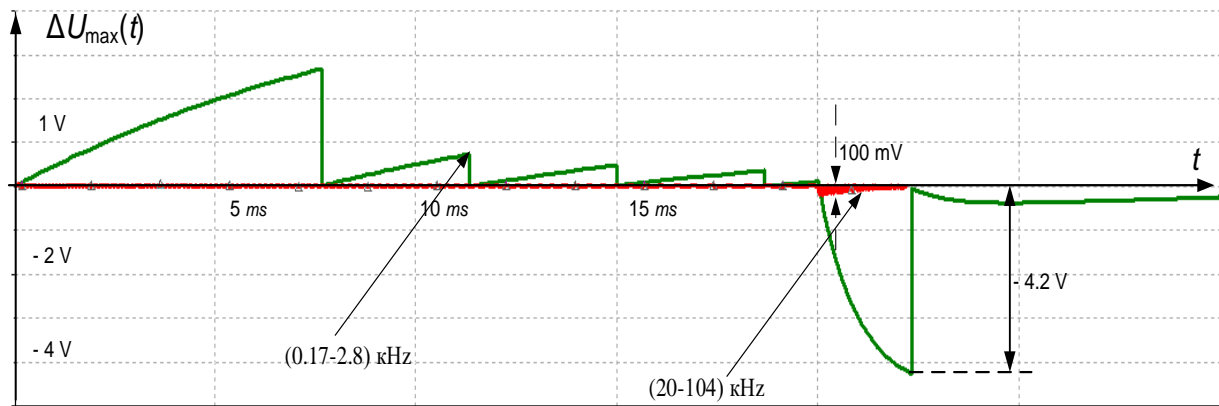

Figure 8. The waveform of error signal $\Delta U_{out}(t)$ at different the electric-tuning range of the VCO, Red line – at electric-tuning range (20–104) kHz; Green line – at electric-tuning range (0.17–2.8) kHz

5. Discussion of the results

Determine the memory size to store the input signal duration $T_c = 24$ MS, when the ADC has a frequency of 100 kHz (sampling period $10 \mu s$), the analog-to-digital converter has 32 bits. Number of samples:

$$N = \frac{T_c}{T_s} = \frac{24 \cdot 10^{-3}}{10 \cdot 10^{-6}} = 24000.$$

where T_s – sampling period, T_c – input signal duration.

The memory size:

$$V = NM = 24000 \cdot 32 = 768 \text{ kbit}$$

where N – number of samples, M – data width.

Next, we define the memory size to store the same signal, but the sampling period of ADC will be determined by the frequency of the VCO. The time constant of the differentiator is $30 \mu\text{s}$ and the VCO has a the electric-tuning range from 20 kHz to 104 kHz. The monitored signal is shown in Figure 9. We approximate the monitored signal in the form of three tangent lines to the input signal (Figure 9).

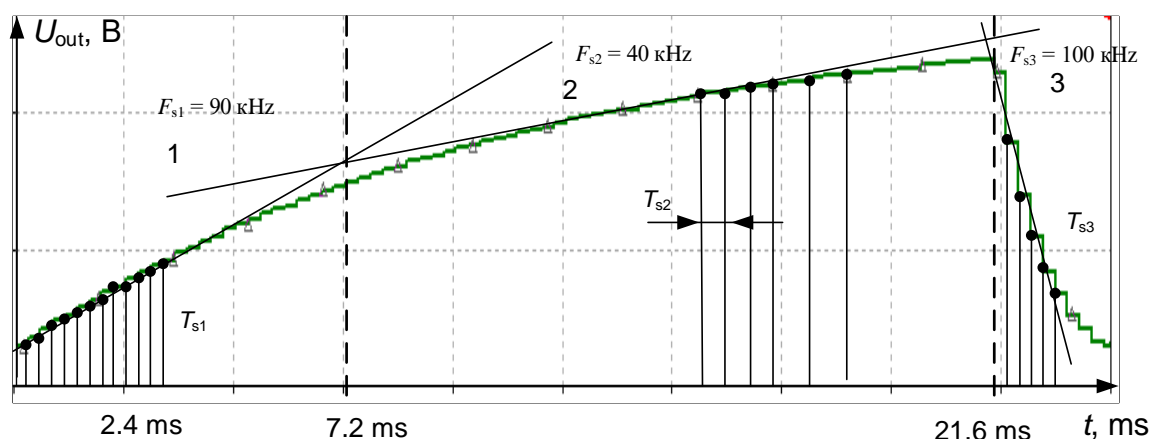

Figure 9. The monitored signal and three tangent lines to the monitored signal

The ADC sampling frequency has three values: $F_{s1} = 90 \text{ kHz}$ (sampling period is $11.1 \mu\text{s}$), $F_{s2} = 40 \text{ kHz}$ (sampling period is $2.5 \mu\text{s}$) and $F_{s3} = 100 \text{ kHz}$ (sampling period is $10 \mu\text{s}$)

We can define the number of samples for each of the three sections:

$$N_1 = \frac{T_{c1}}{T_{s1}} = \frac{7.2 \cdot 10^{-3}}{11.1 \cdot 10^{-6}} = 648;$$

$$N_2 = \frac{T_{c2}}{T_{s2}} = \frac{14.4 \cdot 10^{-3}}{2.5 \cdot 10^{-6}} = 5760;$$

$$N_3 = \frac{T_{c3}}{T_{s3}} = \frac{2.4 \cdot 10^{-3}}{10 \cdot 10^{-6}} = 240.$$

The memory size:

$$V = (N_1 + N_2 + N_3)M = (648 + 5760 + 240) \cdot 32 \approx 213 \text{ kbit}$$

Memory size decreased by 3.6 times and the error is less than 6%.

6. Conclusion

The waveforms of the restored signals at change of parameters of the differentiator and the VCO were produced as a result of modeling. The parameters of the differentiator and the VCO affect the accuracy of the recovery of the monitored signal. The best results are achieved at $\tau_1 = 30 \mu\text{s}$ and 2.3 % error. Worst result at $\tau_2 = 600 \mu\text{s}$ and 65% error.

In order to increase the accuracy of signal recovery, it is recommended to increase the electric-tuning range of the VCO. The proposed approach increases the service life of the RAM, since the sampling period of the ADC depends on the rate of change of the monitored signal. When the derivative of the monitored signal decreases the sampling period of the ADC increases and the data volume decreases.

Acknowledgments

The research is carried out at Tomsk Polytechnic University within the framework of Tomsk Polytechnic University Competitiveness Enhancement Program.

References

- [1] Gel'fand A M, Misrikhanov M S & Fridman L I. 2006 *Autom Remote Control* **67** 726

- [2] Mosin S G 2019 *Tomsk State University Journal of Control and Computer Science* **48** 92
- [3] Babichev S A, Zakharov P A, Kryukov O V 2011 *Autom Remote Control* **72** 175
- [4] Kondrat'ev V V, Uvarov P I 2013 *Autom Remote Control* **74** 2209
- [5] Hyng N H, Utkin V A 2006 *Autom Remote Control* **67** 767
- [6] Kavalerov B V 2013 *Autom Remote Control* **74** 1890
- [7] Dolgii A B 2001 *Automation and Remote Control* **62** 2020
- [8] Chubov S V, Soldatov A I 2016 *Mechanical Engineering, Automation and Control Systems* **177** 012021
- [9] Vedeshenkov V A 2003 *Automation and Remote Control* **64** 1794
- [10] Tselishev D V, Tselishev V A, Konstantinov S Y 2019 *Autom Remote Control* **80** 385
- [11] Abramov B B, Keren O, Levin I S *et al* 2009 *Autom Remote Control* **70** 1217