

The choice of feedstock for the biodiesel production with optimal physicochemical and low-temperature properties

N E Belozertseva, I A Bogdanov, A T Balzhanova and M V Kirgina

Division for Chemical Engineering, Tomsk Polytechnic University, Tomsk, Russia

E-mail: belozertsevanatasha@mail.ru

Abstract. The transesterification reaction of sunflower, mustard and linseed oil with ethyl alcohol was studied using potassium hydroxide as a catalyst. The physicochemical properties and low-temperature characteristics of the feedstock and obtained products were studied. The most preferred feedstock for the biodiesel fuel production had been determined.

1. Introduction

In the modern world the motor fuels consumption is increasing every year [1, 2], which leads to an increase in oil production, the development of new fields and, consequently, to reserves depletion and higher prices for hydrocarbons feedstock. With the rise in oil prices interest in alternative energy increases. One of the most popular types of alternative fuel is biodiesel, an environmentally friendly and safe to use energy source, the feedstock for the production of which is renewable. In addition, the biodiesel production allows recycling of food and industrial waste, such as waste oil.

Biodiesel has advantages over conventional diesel in terms of aromatic hydrocarbon content, sulfur, flash point and biodestruction. It can be used on mechanic transport both in pure form and as a mixture with diesel fuel. Biodiesel is the only alternative energy source that is suitable for all mechanic transport with conventional diesel engines [3].

From a chemical point of view, biodiesel fuel is a monoesters mixture of higher fatty acids, obtained by transesterification of vegetable oils and animal fats [4]. Feedstock for the biodiesel production is oilseed lipids. The main crops used are rape (EU countries), sunflower (France, Italy), soybean (USA, Brazil and African countries), canola (Canada), palm oil (Indonesia, Malaysia) and jatropha (India, African countries). The main fatty acids contained in the oilseeds lipids are palm, oleic and linoleic acids.

A large number of works are devoted to the biodiesel fuels production; researchers in this direction are working all over the world. Therefore, the authors of the article [5] describe in detail the various parameters effect on the process of obtaining biodiesel from oilseed plants. To achieve a high biodiesel yield, it is necessary to optimize a variety of catalytic variables, such as catalyst type and composition, carrier type and pretreatment conditions (for example, temperature and calcination time). In addition, many operation conditions require adjustments such as the reaction temperature, alcohol type, molar ratio of alcohol to oil and stirring speed.

A homogeneous alkaline catalyst such as sodium hydroxide (NaOH), sodium methoxide (NaOCH₃), potassium hydroxide (KOH), or a homogeneous acid catalyst, such as sulfuric acid (H₂SO₄) or hydrochloric acid (HCl) can catalyze the transesterification reaction. Homogeneous alkaline catalysts are considered more preferable despite the fact that the transesterification reaction in the presence of this catalysts type causes saponification of the triglyceride or the product of fatty acid methyl ester.



Saponification increases the catalyst consumption, reduces the biodiesel yield and complicates separation processes after the biodiesel production.

Acidic catalysts compared with alkaline do not lead to saponification, but the reaction rate is lower. Therefore, the reaction requires higher temperatures and pressures to achieve the desired conversion. Separation and purification of the product is simple; therefore, the reaction is more economically feasible and the catalyst can be reused after a simple filtration process [6, 7]. In addition to these, heterogeneous catalysts such as alkali metal carbonates (Na_2CO_3 , K_2CO_3), alkaline earth metal carbonates (CaCO_3), oxides of alkaline earth metals (CaO , MgO , SrO , BaO) and other oxides such as ZnO are also used [8].

In addition to alkaline heterogeneous catalysts, green biocatalysts are currently attracting the scientific community attention due to their energy-efficient enzymatic properties. In [9–11], it was found that by using immobilization or in the liquid phase, high yields can be achieved with the help of reliable lipase enzymes. Enzymatic process can be easily combined with the latest technologies (for example, ultrasonic), work in a continuous mode using various reactors designs; also the enzymes lifetime can be improved in order to take further steps towards industrial production. Last but not least, the use of metagenomics in enzyme technologies opens up broad prospects for the development of stable and solvent-resistant biocatalysts for the biodiesel production [9, 12].

For the transesterification reaction, alcohols such as methanol, ethanol, propanol, butanol, pentanol, and amyl alcohol are commonly used.

In the majority of existing methods, methyl alcohol is used as a transesterifying component, which is a toxic liquid of the third hazard class, which has a damaging effect on the human nervous system and vascular system when inhaled through the respiratory system or the skin. Therefore, for safety reasons, it is advisable to use ethyl alcohol, which, in addition, is a more affordable feedstock. However, the biodiesel production using ethanol as a transesterifying agent has not occurrence due to the high solubility of the esters obtained in this alcohol, which makes it difficult to isolate the desired reaction products and leads to a lower yield of the final product.

Both methanol and ethanol have advantages and disadvantages. For example, the reaction with methanol is faster at a lower temperature compared to the reaction using ethanol [12], in addition, the reaction with methanol gives a higher biodiesel yield. However, ethanol obtained by renewable methods, in some cases, for example, by transesterification of soybean oil, increases the reaction rate [13].

To increase the alcohol / oil ratio, there are practically no restrictions, however, the authors of [14] showed that the increase in the ratio is effective only up to a certain limit. However, the authors of article [15] confirm that during the transesterification of soybean oil with methanol with a Li-doped MgO catalyst, the alcohol to oil ratio of more than 15 complicates the processes of heating and separating the product, the optimum ratio is from 12 to 15. The authors of [16] found that the ratio of alcohol to oil, exceeding 30, is harmful due to the increased solubility of the glycerol product in the reaction mixture. However, in the case of the transesterification reaction of rapeseed oil with methanol and Zn / Al catalyst carried out in high-pressure autoclaves at high temperatures, it was found that a higher alcohol to oil ratio is favorable.

One of the important variables that effects on the transesterification reaction rate is temperature. Although the reaction can be carried out at room temperature, which the authors of [17] successfully implement, based on the kinetics, the reaction rate increases with increasing temperature. Moreover, in the case of oils transesterification higher temperatures lead to decrease in oil viscosity and better reagents mixing.

Nevertheless, there is an optimal reaction temperature and its further increase causes a decrease in the biodiesel yield due to increased saponification (in the case of homogeneous alkaline catalysts), as well as the rapid evaporation of the used alcohol [18]. Consequently, the reaction temperature is usually maintained below the boiling point of the alcohol; however, it is possible to carry out the reaction at higher temperatures under reflux conditions or at high pressure.

A literature review showed that the process of biodiesel production from oil plants has a wide range of temperatures, pressures and ratios of raw feedstock. This gives a huge field to study the biodiesel production and the products properties that also change with changing reaction conditions.

The most significant biodiesel characteristics are viscosity, lubricity, flash point, cetane index and low temperature properties. These properties play a decisive role in the equipment design for the biofuels use in diesel engines, in the fuel operation in different climatic conditions.

Thus, the study purpose is to determine the most preferred feedstock for the biodiesel fuel production with optimal physicochemical and low-temperature properties.

To achieve this goal, the following tasks were determined:

- investigate the physicochemical properties and low-temperature characteristics of feedstock for the biodiesel fuel production (vegetable oils);
- choose a method for the biodiesel synthesis;
- investigate the physicochemical properties and low-temperature characteristics of the obtained products (complex mixtures consisting of ethyl esters of fatty acids – biodiesel fuel).

2. Experimental part

Sunflower, mustard and linseed unrefined edible oils from various manufacturers were used as feedstock for biodiesel production.

Ethyl alcohol was used as a transesterifying agent.

The molar ratio “ethanol: oil” is assumed to be 9: 1 based on the molar masses of alcohol and vegetable oil. When the molar ratio is less than 9: 1, the reaction is incomplete, with an increase in the molar ratio, the separation of glycerol becomes more difficult and the yield of ethers decreases.

The reactor was a heat-resistant beaker 4 in the volume of 1 liter, located on the electric stove 5, equipped with a stirrer 1 and a thermometer 3 (Figure 1). The top of the heat-resistant beaker was covered with metal foil to prevent volatilization of alcohol vapors during the reaction.

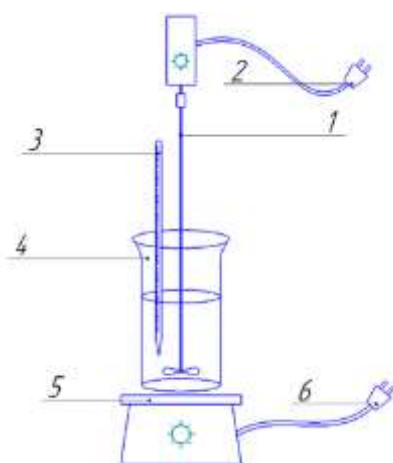

Figure 1. Simplified diagram of the laboratory unit for the transesterification reaction: 1 – automatic blade stirrer; 2 – power-intake connection yoke for blade stirrer to the electricity mains; 3 – thermometer; 4 – heat-resistant beaker; 5 – electric stove with heat control; 6 – power-intake connection yoke for electric stove to the electricity mains.

Vegetable oil was placed in a heat-resistant beaker, slowly heated to 75 °C with constant stirring, then the catalyst was introduced and the reaction time was started. An alcoholic solution of potassium hydroxide was used as a catalyst. The reaction time was 6 hours. At the end of the synthesis, the reaction mixture was cooled to room temperature and glycerol was added, which contributed to the formation of two phases. The beaker's contents were transferred to a separation funnel for further processing. After settling, two phases were formed – the upper one consisting of ethyl esters of vegetable oils and residual ethanol, and the lower one containing glycerin, an excess of ethanol, unreacted potassium hydroxide, formed soaps and products of incomplete transesterification. The obtained ethyl esters were purified from residual ethanol using a rotary evaporator. The catalyst was removed by sequential washing with 1 % citric acid solution (until neutral pH) and then with distilled water.

The use of a rotary evaporator can significantly reduce losses during the distillation of ethyl alcohol and eliminate the stage of drying the obtained product.

3. Results and discussion

The paper was examined various feedstock options (vegetable oil) for the biodiesel fuel production. The physicochemical properties of three different vegetable oils (sunflower, mustard, linseed) were investigated. The results of measurements of the kinematic viscosity [19], dynamic viscosity [19] and density [20] are shown in tables 1–3, respectively.

Table 1. Kinematic viscosity of vegetable oils.

Vegetable oil	Kinematic viscosity at 15 °C (m ² /s)	Kinematic viscosity at 20 °C (m ² /s)
Sunflower oil	77.76·10 ⁻⁶	62.46·10 ⁻⁶
Mustard oil	90.26·10 ⁻⁶	72.14·10 ⁻⁶
Linseed oil	62.41·10 ⁻⁶	51.07·10 ⁻⁶

Table 2. Dynamic viscosity of vegetable oils.

Vegetable oil	Dynamic viscosity at 15 °C (Pa·s)	Dynamic viscosity at 20 °C (Pa·s)
Sunflower oil	71.77·10 ⁻³	57.43·10 ⁻³
Mustard oil	83.05·10 ⁻³	66.14·10 ⁻³
Linseed oil	58.13·10 ⁻³	47.41·10 ⁻³

Table 3. Density of vegetable oils.

Vegetable oil	Density at 15 °C (kg/m ³)	Density at 20 °C (kg/m ³)
Sunflower oil	922.9	919.6
Mustard oil	920.1	916.8
Linseed oil	931.5	928.4

From the data presented in tables 1–3 it can be seen that linseed oil has the lowest both kinematic and dynamic viscosity at temperatures of 15 °C and 20 °C. While the least density at temperatures of 15 °C and 20 °C has mustard oil.

Low-temperature characteristics, such as cloud point [21] and pour point [22], were also determined for feedstock for biodiesel fuel production. The results are shown in table 4.

Table 4. Cloud point and pour point of vegetable oils.

Vegetable oil	Cloud point (°C)	Pour point (°C)
Sunflower oil	-9	-19
Mustard oil	-18	-29
Linseed oil	-13	-16

From the data presented in table 4, we can conclude that mustard oil has the best low-temperature characteristics, sunflower oil – the worst.

The result of triglyceride esters transesterification contained in vegetable oil under the low alcohols action in the catalyst presence is a complex mixture formation consisting of fatty acids ethyl esters – the main synthesis product – biodiesel fuel.

Thus, the overall efficiency of the biodiesel production technology is determined by the conversion degree of the feedstock and the ethyl esters yield of vegetable oils. Product yields for various vegetable oils are presented in table 5.

Table 5. The yields of the mixture of fatty acids ethyl esters obtained from vegetable oils.

Product	Mass of feedstock (g)	Yield (%)
Sunflower oil product	584.40	59.12
Mustard oil product	573.20	50.37
Linseed oil product	567.10	51.28

As can be seen from table 5, which presents the product yields after residual alcohol distillation, the highest yield is observed for the product obtained from sunflower oil, the lowest – for the product obtained from mustard oil.

For the obtained biodiesel fuels were determined physicochemical properties. The results of determining the kinematic viscosity [19], dynamic viscosity [19] and density [20] are shown in tables 6–8, respectively.

Table 6. Kinematic viscosity of obtained biodiesel fuels.

Product	Kinematic viscosity at 15 °C (m ² /s)	Kinematic viscosity at 20 °C (m ² /s)
Sunflower oil product	20.37·10 ⁻⁶	17.19·10 ⁻⁶
Mustard oil product	25.81·10 ⁻⁶	21.73·10 ⁻⁶
Linseed oil product	20.96·10 ⁻⁶	17.88·10 ⁻⁶

Table 7. Dynamic viscosity of obtained biodiesel fuels.

Product	Dynamic viscosity at 15 °C (Pa·s)	Dynamic viscosity at 20 °C (Pa·s)
Sunflower oil product	18.43·10 ⁻³	15.49·10 ⁻³
Mustard oil product	23.36·10 ⁻³	19.60·10 ⁻³
Linseed oil product	19.18·10 ⁻³	16.29·10 ⁻³

When comparing the kinematic viscosity of the feedstock for the biodiesel fuel synthesis (table 1) and the obtained products (table 6), it can be noted that cause of the transesterification reaction, the kinematic viscosity decreased more than three times for each of the products.

Products from sunflower and linseed oil have similar kinematic viscosity values, in contrast to the product obtained from mustard oil, the viscosity of which is the highest among those presented.

Similar trends are observed for dynamic viscosity values (the product obtained from sunflower oil has the lowest dynamic viscosity, the product obtained from mustard oil has the highest viscosity).

Table 8. Density of obtained biodiesel fuels.

Product	Density at 15 °C (kg/m ³)	Density at 20 °C (kg/m ³)
Sunflower oil product	904.7	901.0
Mustard oil product	905.0	901.7
Linseed oil product	915.1	911.4

When comparing the density of feedstock for the biodiesel synthesis (table 3) and the obtained mixtures of fatty acids ethyl esters (table 8), it should be noted that the density of each obtained product decreased by more than 15 kg/m³. A product obtained from linseed oil characterizes the highest density, both at 15 °C and at 20 °C. While the product obtained from sunflower oil has the lowest density at 15 °C; the product obtained from mustard oil has the lowest density at 20 °C.

A significant decrease in each of the physicochemical characteristics has a positive effect on the possibility of using biodiesel fuel for vehicles, since viscous and heavy fuel makes it difficult for the engine to work.

During the study of the literature, it was found that not many authors pay attention to the low-temperature characteristics of the mixtures of fatty acids ethyl esters. For the cold climate that prevails in most of Russian Federation territory, the issue of compliance of the low-temperature characteristics of the obtained products with the existing standards is most acute.

In the work process, the cloud point [21] and pour point [22] of the transesterification reaction products were determined. The results are presented in table 9.

Table 9. Cloud point and pour point of obtained biodiesel fuels.

Product	Cloud point (°C)	Pour point (°C)
Sunflower oil product	+7	-8
Mustard oil product	-11	-14
Linseed oil product	-10	-12

An overall deterioration in the low-temperature properties of the obtained products is observed in comparison with the corresponding characteristics of the feedstock (table 4). The product obtained from mustard oil has the best cloud point and pour point; the product obtained from sunflower oil – is the worst.

4. Conclusions

Based on the investigation results the following conclusions were made:

- Complex mixture of ethyl esters, obtained from sunflower oil, is characterized by the highest yield, as well as the lowest viscosity values. Thus, based on the physicochemical properties of the obtained products, sunflower oil is the most preferable feedstock for biodiesel production, which is also the most optimal for processing from an economic point of view.
- It was found that products derived from mustard oil have the best low-temperature properties. Thus, mustard oil is the most optimal feedstock in terms of low-temperature characteristics, which plays an important role in cold climate conditions.

References

- [1] Belinskaya N 2016 *Pet. and Coal* **58** (1) 126–134
- [2] Kirgina M, Bogdanov I, Altynov A and Belinskaya N 2019 *Pet. and Coal* **61** (1) 110–119
- [3] Braginskij O 2008 *Ros. him. zhurnal [Russian chemical journal]* **52** (6) 137–146
- [4] Dvoreckij S, Zazulya A, Nagornov S, Romancova S and Ryazanceva I 2012 *Vopr. sovr. nauki i*

- pr. [Problems of Contemporary Science and Practice]* (39) 126–35
- [5] Günay M, Türker L and Tapan N 2019 *Fuel* **250** 27–41
- [6] Tapan N, Yıldırım R and Günay M 2016 *Biofuels, Bioprod. Biorefin* **10** (4) 422–34
- [7] Islam A, Taufiq-Yap Y, Chan E, Moniruzzaman M, Islam S and Nabi M 2014 *Energy Convers. Manage* **88** 1200–1218
- [8] Sharma Y, Singh B and Korstad J 2011 *Fuel* **90** (4) 1309–1324
- [9] Gusniah A, Veny H and Hamzah F 2019 *Ind. Eng. Chem. Res* **58** (2) 581–589
- [10] Hama S, Noda H and Kondo A 2018 *Curr. Opin. Biotechnol* **50** 57–64
- [11] Tacias-Pascacio V *et al* 2019 *Renewable Energy* **135** 1–9
- [12] Meneghetti S *et al* 2006 *Energy Fuels* **20** (5) 2262–265
- [13] Ghesti G *et al* 2009 *Appl. Catal. A* **355** (1–2) 139–147
- [14] Sai A, Niju S, Meera K and Anantharaman N 2019 *Energy Sources A* **41** (15) 1862–1878
- [15] Wen Z, Yu X, Tu S, Yan J and Dahlquist E 2010 *Appl. Energy* **87** (3) 743–748
- [16] Xie W and Wang T 2013 *Fuel Process. Technol.* **109** 150–155
- [17] Yang X, Wang Y, Yang Y, Feng E, Luo J, Zhang F, Yang W and Bao G 2018 *Energy Convers. Manage* **164** 112–121
- [18] Abbah E, Nwandikom G, Egwuonwu C and Nwakuba N 2016 *American Journal of Energy Science* **3** (3) 16–20
- [19] ISO 3104: 1994 Petroleum products. Transparent and opaque liquids. Determination of kinematic viscosity and calculation of dynamic viscosity
- [20] ISO 12185:1996 Crude petroleum and petroleum products – Determination of density – Oscillating U-tube method
- [21] ASTM D2500-05 Standard Test Method for Cloud Point of Petroleum Products
- [22] ASTM D97-17b Standard Test Method for Pour Point of Petroleum Products