

TECHNICAL NOTE
ALUTEAM TN-2016/001

SELECTIVE LASER SINTERING OF
ALUMINUM EXTRUSION DIES

Ebubekir KOC, Yaşar AKCA, Z. Cagatay OTER, Mert COSKUN

The Aluminum Test Training and Research Center
Fatih Sultan Mehmet Vakıf University
Sütlüce Mah. Karaağaç Cad. No:12/A
Beyoğlu, Istanbul
Turkey

December 2016

Table of Content

Table of Content.....	1
Abstract	2
1. Introduction	3
2. Literature Review	5
3. Methodology	6
4. Results	11
5. Discussion	13
6. Conclusions	14
Acknowledgement.....	14
References	15

TECHNICAL NOTE
ALUTEAM TN-2016/001

**SELECTIVE LASER SINTERING OF
ALUMINUM EXTRUSION DIES**

Ebubekir KOC, Yaşar AKCA, Z. Cagatay OTER, Mert COSKUN

The Aluminum Test Training and Research Center
Fatih Sultan Mehmet Vakıf University
Sütlüce Mah. Karaağaç Cad. No:12/A
Beyoğlu, Istanbul
Turkey

Abstract

In this study, geometric forms of maraging steel dies used in aluminum extrusion were optimized by means of flow dynamics as well as surface quality and mechanical properties of the final part. Maraging steel (MS1) dies were produced by Direct Metal Laser Sintering (DMLS), a Selective Laser Sintering (SLS) method, using EOS M290. Dies were not subjected to any conventional finishing post processes. Field tests were carried out in an industrial aluminum extrusion facility. Results presented that DMLS is a promising method for the production of dies with complex inner sections with high accuracy, high speed and low cost. Production of high quality extruded profiles was possible using additive manufactured dies directly from production without applying any finishing post process.

Keywords: Aluminum extrusion, Rapid Tooling, Additive Manufacturing, Selective Laser Sintering, Direct Metal Laser Sintering, DMLS.

1. Introduction

Extrusion is a process where an aluminum billet is pushed through a die by a ram or screw to create objects of a fixed cross-sectional profile. The die has a cavity in the form of the final extruded cross section. Main advantages of extrusion process are the ability to create very complex cross-sections, to form profiles with excellent surface finish, and to work with materials that are brittle [1]. Aluminum is the most commonly extruded material. Examples of products include profiles for tracks, frames, rails, mullions, and heat sinks.

An extrusion die is simply a steel disk with an opening, the size and shape of the cross-section of the final profile, cut through it. The opening includes all the geometric details and dimensional tolerances of the final product. Consequently, faults that are present in the die are directly reflected in the profile. These faults are geometrical and dimensional errors as well as surface flaws. Extrusion dies can be designed and produced with a virtually limitless array of shapes and sizes. Die design and shape affect the extrusion pressure, speed, exit temperature, material flow and friction. The pressure in the extrusion of fine-sectioned profiles is very high and the die needs to be supported by a backing to prevent bending and cracking under high pressure. Therefore, dies are used together with components such as backer and bloater. These components are processed (machining, honing, shaving etc.) to reduce friction thus enhance material flow and profile surface quality [1-5]. Faults such as cracks, stress accumulation, improper processing (burning), commonly occur in extrusion dies produced by conventional production techniques. Due to the limited capabilities of existing production systems and 2-dimensional perspective in die design, the package length of multi-portal and long-tongue dies, in particular, grow unnecessarily and production of such dies can be impossible. As the package size of the dies grows, the internal friction increases and therefore the mechanical and surface properties of the products deteriorate and the capacities of the presses must be increased.

Selective laser sintering (SLS) is a novel manufacturing method which has been utilized by many industries especially for complex parts productions. As part of additive manufacturing technology, SLS based on fine layers of powder materials being fused by laser energy to create complex structures. In this technique, a solid layer is formed by using a high energy laser directly from the data in the CAD drawings of the parts to be produced by partially melting and sintering the metal powders at the appropriate points to form the part geometry [6-9]. The manufacturing process which is carried out by adding these layers on top of each other makes it possible to produce engineering parts with complex geometries, internal features and passages that are not easy to produce with traditional production techniques (machining, casting, and forging) [9-12]. DMLS provides the possibility to produce fine details with high precision, and is a high time and cost-saving technology with the ability to annihilate manufacturing processes such as die design, tool shaping etc. and produce multiple parts simultaneously. This method allows metal parts with complex shapes to be produced directly from metal powders without using conventional metal forming tools [11,13,14].

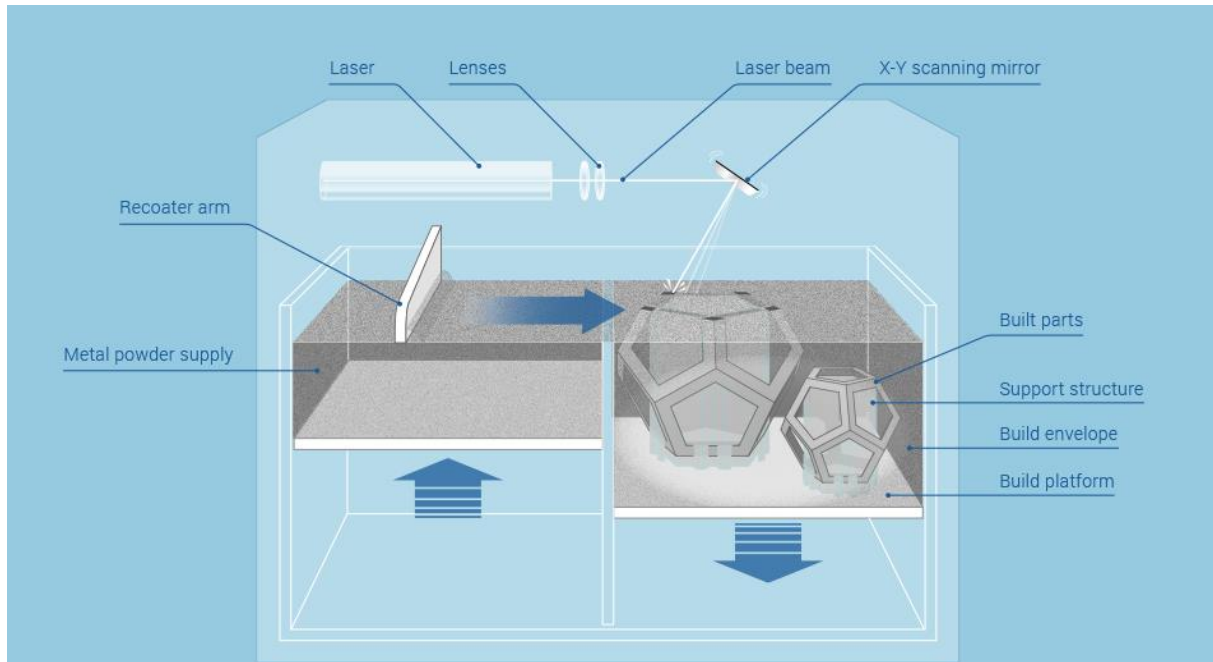

Figure 1. Selective laser sintering technology [15]

The aim of this study was to alter the existing design concept of extrusion dies based on a novel 3-dimensional perspective within the geometrical limits of Selective Laser Sintering (SLS) and to resolve the limits in die production which are introduced by conventional linear design perspective. Geometric forms of maraging steel dies used in aluminum extrusion were optimized by means of flow dynamics as well as surface quality and mechanical properties of the final part. Multiple-bridge dies have large set sizes due to lack of flexibility of conventional die production methods. It is possible to decrease the pressure and temperature due to friction and geometry in such dies by decreasing the set size. In addition, optimization of the flow dynamics of the extrusion dies improve the mechanical and surface properties of the products.

Section 2 details the literature review and presents the previous works related to aluminium extrusion dies. Section 3 describes the methodology as well as design details of extrusion dies and field trials. In section 4 and 5, results are presented and discussed with details. Section 6 gives the concluding remarks and future works to be done.

2. Literature Review

In recent years, owing to the improvements in machinery and materials, additive manufacturing technology, which has many more applications the industries, has begun to be used in the production of extrusion dies. However, additive manufacturing of the entire extrusion die set (die matrix, bloater, backer and other components) from maraging steel has not yet been undertaken. The main reason for this lack of literature is thought to be as follows:

- Product surface quality is limited by the Z-axis and grain size.
- Surface finishing processes are needed.
- The support mechanisms must cover the entire construction. Die sets should be redesigned to optimize support systems.
- Machining of support structures requires additional workmanship and materials.
- Material variety is limited (stainless steel, maraging steel, cobalt chromium, Inconel 625, Inconel 718, AlSi10Mg, and Ti6Al4V)
- Production cost is high compared to conventional methods.

Consequently, most of the studies are on the construction of the important geometrical structure (die matrix) by additive manufacturing on an existing hot work steel die set (hybrid production). Studies were carried out especially on the design of cooling channels to increase production speed and surface quality.

Hönkel et al. [16], studied the production of an extrusion die with integrated local cooling channels by Selective Laser Melting (SLM). To analyze the effects of this cooling system, hot extrusion trials with different ram speeds (6, 12, 18, 24 m/min) and preheating temperatures were performed. Results of this study revealed that exit temperature of the profile was reduced significantly (41°C) at low ram speeds. However, at high ram speeds, surface defects in the shape of stripes of high roughness occurred. It was reported that these defects could be prevented by internal die cooling.

Recently, Hörkel et. Al (2016) studied the hybrid production of aluminum alloys by Selective Laser Melting (SLM). In this study, the die bridge was manufactured conventionally by subtractive methods and the part with the complex geometry was built-up on the conventional die by SLM. An isolated cooling channel for local cooling was produced inside this part. The results indicate that extrusion exit temperature was locally reduced and controlled. It was shown that hybrid tools can withstand the high mechanical and thermal loads that occur during hot extrusion [17].

These studies found in literature were focused solely on the improvement of conventional die designs in a number of contexts by combining Selective Laser Melting (SLM) method with conventional production concepts.

3. Methodology

Aluminum extrusion dies should be resistant to high temperature, fatigue, wear and should have high thermal conductivity. The characteristics of the part produced, as it is in all powder metallurgy methods, depends highly on raw material (powder), production technology and process parameters [18]. Therefore, dies made of hot work tool steels are generally preferred. Table 1 gives the chemical composition of 1.2344 hot work tool steel commonly used in extrusion. Table 2 gives the mechanical properties of 1.2344 hot work tool steel [4].

Table 1. Chemical composition of 1.2344 hot work tool steel [4].

Standard	C	Si	Mn	P	S	Cr	Mo	V	Nb
DIN 1.2344 (X40CrMoV5-1)	0,4	1	0,35	<0,02	<0,005	5,2	1,3	1	-

Table 2. Mechanical properties of 1.2344 hot work tool steel [4].

Standard	Tensile Strength (MPa)		Hardness (HRC)	
	RT	550°C	RT	550°C
DIN 1.2344	1920 MPa	1765 MPa	55	52

Maraging steel used in this study is commonly used for the production of plastic injection dies. Table 3 gives the chemical composition of 1.2709 maraging steel [19]. Table 4 gives the mechanical properties of DMLS maraging steel products, provided by EOS [20].

Table 3. Chemical composition of 1.2709 maraging steel [20].

Standard	C	Si	Mn	Ni	Co	Ti	Mo
DIN 1.2709	=<0,03	=<1	=<1	17-19	9-11	0,9-1	4-6

Table 4. Mechanical properties of DMLS maraging steel products, provided by EOS [20].

Property	As built	Age hardened
Tensile strength		Min. 1930 MPa
Horizontal (XY)	Typ. 1100+-100MPa	Typ. 2050+- 100MPa
Vertical (Z)	Typ. 1100+-100MPa	
Yield strength (0,2%)		Min. 1862 MPa
Horizontal (XY)	Typ. 1050+-100MPa	Typ. 1990+-100MPa
Vertical (Z)	Typ. 1050+-100MPa	
Elongation at break		Min. 2%
Horizontal (XY)	Typ. 10+-4 %	Typ. 4+-2%
Vertical (Z)	Typ. 10+-4 %	
Hardness	Typ. 33-37 HRC	Typ. 50-56 HRC

In the first stage of this study, production of the die with the design given in Figure 2 was carried out. The aim of this stage was to investigate the manufacturability and the properties of the simple geometry (solid-bridged) dies and to determine the difficulties and necessary precautions for DMLS. The conventional die design was optimized with a 3-dimensional perspective and production was completed in 18 hours. Images of the die are given in Figure 3.

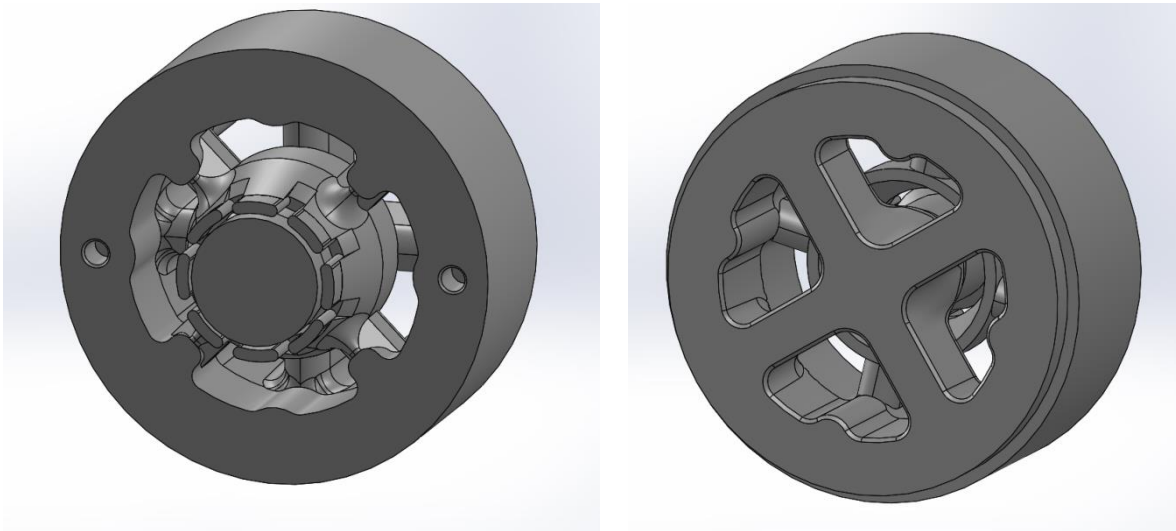

Figure 2. 3-Dimensional solid model of the die to be produced from maraging steel.



Figure 3. Solid die with simple geometry produced by DMLS.

Before the extrusion operations, the aluminum billet is heated to 440-470°C, the die is heated to 450-460°C and the container is heated to 420°C. The billet is pushed through the die section with a pressure of approx. 67 kg/mm² ($\pm 10\%$). Temperature of the extruded profile is approx. 500°C. To test the mechanical properties of maraging steel die at operation temperatures, annealing in at 550°C for 3, 6, 9 and 12 hours followed by air cooling and hardness measurement was carried out (see Table 6).

Following the aforementioned preliminary study, it has been decided to perform field tests on a solid die produced by DMLS for the following reasons:

- Observation of the flexing behavior of the die under pressure
- Observation of tribological behavior between the die and the aluminum billet
- Observation of hardness variations due to operation temperatures
- Inspection of the extruded profile surfaces with and without coating (eloxal)

In the second stage of this study, a two-hole solid die design for a cross section with sharp edges and flat surfaces was used to observe all possible problems and develop solutions. In this stage conventional die materials and additive manufactured materials were combined. The aim of this stage was to produce the parts which have no effect on the die geometry and the mechanical and surface properties of the product by conventional methods and the strategic parts by DMLS. Thus, it was possible to determine the problems to be encountered in multiple-bridged dies and to acquire the data required to reduce the cost of DMLS. Production of the die was completed in 58 hours (see Figure 4a). Following the DMLS process, the production platform and the die was annealed at 490°C for 8 hours to reduce the residual stresses through the die section (see Figure 4b). Surface hardness of the die was measured both after production and stress relieving.



Figure 4. Extrusion die, (a) as produced in EOS M290 machine and (b) after stress relieving.

The inner surfaces of the die cavities were polished. No finishing post-processes were applied to the die. The backer and the bolster of the die set were made of 1.2344 hot work steel by conventional methods. Images of the die set with all components are given in Figure 5. Surface hardness of each component of the die set was measured using a portable hardness tester (see Table 7). System tests of the die were carried out using US1100Ton extrusion press. Test conditions are given in Table 1.



Figure 5. Combined die set including all components.

Table 5. Field test conditions for die set

Die temp. (°C)	Initial	Final
	443	430
Furnace temp. (°C)	Initial	Final
	553	500
Billet temp. (°C)	480	
Exp. pressure (Bar)	Initial	Final
	180	150
Extrusion pressure (Bar)	Initial	Final
	50	50
Speed (m/min.)	Initial	Final
	14	43
Profile temp. (°C)	553	
Profile weight (kg/m)	0.209	

4. Results

Average hardness values of maraging steel die acquired at each step of the study are given in Table 6. Typical hardness of 1.2344 hot work steel is 52 and 55 HRC at room temperature and at 550°C respectively. Results showed that the hardness values of the dies produced by DMLS were satisfactory after stress relieving and annealing (550°C, 3h) processes.

Hardness values of the die set components measured by the portable hardness tester are given in Table 7. Measurements revealed that hardness values, therefore mechanical properties, of the die set components were suitable to be used in production.

Images taken during field tests of the die set are given in Figure 6. Figure 6 (a) shows the extrusion process by US1100 tons press and the image of the die after manufacturing process, taken out of the machine is given in Figure 6 (b). Then die was sent to post processing unit for causticization. Images of the extruded profile surfaces (uncoated, after eloxal coating, after static powder paint) are given in Figure 7.

Table 6. Average HRC hardness values of the extrusion die after each step of production

Surface #	After Production	After Stress Relieving	After Annealing (550°C, 3h)	After Annealing (550°C, 6h)	After Annealing (550°C, 9h)	After Annealing (550°C, 12h)
1	34.87	53.87	51.23	47.53	50.40	48.57
2	34.00	53.63	52.77	49.10	45.57	44.87
3	34.47	56.30	51.70	50.73	45.37	45.87
4	34.93	55.37	53.03	49.13	46.90	48.33
5	31.67	53.30	51.83	49.33	49.83	47.93
6	39.07	53.00	51.40	49.47	48.40	47.20

Table 7. Average surface hardness values of die components

Component	Average Hardness (HRC)
Backer (1.2344 Steel)	47.3
Bolster (1.2344 Steel)	47.1
Die (Maraging Steel)	53.4



(a)

(b)

Figure 6. Field tests of the die set

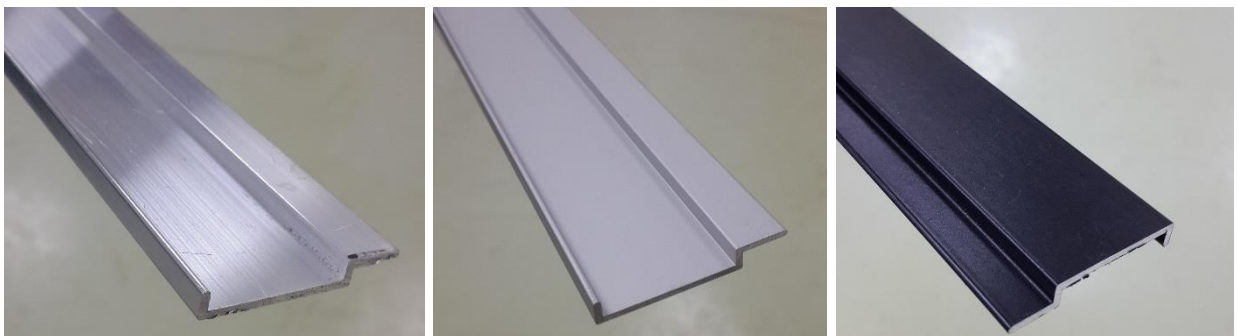

Figure 7. Images of the extruded profile surfaces. (a) uncoated, (b) after eloxal coating, (c) after static powder paint

5. Discussion

After the DMLS production, the die was not subjected to any finishing operations other than polishing. Results presented that a mathematically designed solid extrusion die could be used without further processing if the production was optimized. The machining process in conventional die manufacturing causes further involuntary faults and an extra allocation process is carried out to correct it. DMLS makes it possible to eliminate these allocation (correction) operations. The surface and dimensional controls of the as-produced die were suitable to be used directly in production with no need to further post processing for allocation.

During the extrusion process, the profile at the die outlet temperature was measured to be no more than 550°C. Faults such as color, change, directed lines commonly encountered in anodic oxidation and static powder paint which are caused by an inhomogeneous heat distribution at the die outlet were not observed. At the controls on the outlet ends, it was seen that the profiles were ejected from the die in the ideal flow. No obvious signs of flexing were observed on the product. Although no surface treatment was performed on the extrusion die produced by DMLS, there were no surface defects such as scratches, bubbles and tears on the products.

6. Conclusions

Results of this study showed that by optimizing ideal flow dynamics in multiple-bridged dies and reducing the size of die set;

- Mechanical and surface properties of products can be improved by obtaining ideal flow dynamics, low pressure and temperature.
- Application of multi-bridged dies in low pressure presses can be provided.
- Competition conditions of die manufacturers can be improved.

Acknowledgement

The research described in this technical note was performed as part of the ALUMINIUM GUIDED PROJECT supported by Istanbul Development Agency (ISTKA) and T.R. Ministry of Development. The research also supported by 4-EL Dies Industries Ltd. for development and Altinel Aluminum Extrusion Ltd. for field tests. The financial and field supports are greatly acknowledged.

References

- [1] Saha K. P., “Aluminum Extrusion Technology” (2000), ASM International, Materials Park OH, USA
- [2] Steeltech, “<http://www.steeltec-celik.com.tr/>”, Received: December 2016
- [3] Başaran D., “Aluminum Extrusion Die Design That Reducing Riping” (2010) Master’s Thesis, Gebze Institute of Technology, Department of Mechanical Engineering, Kocaeli, Turkey
- [4] Kind&Co Edelmetallwerk, “Hot Work Tool Steel TQ1”, Wiehl-Bielstein
- [5] Serim İ., “Kalıp Geometrisi, Sertliği ve Yüzey Kalitesinin Çeliğin Sıcak Ekstrüzyonunda Kalıp Geometrisine Etkisi” (1982), PhD Thesis, Dokuz Eylül University, Faculty Engineering-Architecture, Izmir, Turkey
- [6] Simchi, A., “Direct Laser Sintering of Metal Powders: Mechanism, Kinetics and Microstructural Features.” (2006), *Materials Science & Engineering* 428:148–58.
- [7] Calignano, F., D. Manfredi, E. P. Ambrosio, L. Iuliano, and P. Fino., “Influence of Process Parameters on Surface Roughness of Aluminum Parts Produced by DMLS.” (2013), *International Journal of Advanced Manufacturing Technology* 67(9–12):2743–51.
- [8] Khaing, M. W., J. Y. H. Fuh, and L. Lu., “Direct Metal Laser Sintering for Rapid Tooling: Processing and Characterisation of EOS Parts.” (2001), p. 269–72 in *Journal of Materials Processing Technology*, vol. 113.
- [9] Becker, T. H., M. Beck, and C. Scheffer., “Microstructure and Mechanical Properties of Direct Metal Laser Sintered Ti- 6Al-4V.” (2015), *South African Journal of Industrial Engineering* 26(May):1–10.
- [10] Kruth, J. P., G. Levy, F. Klocke, and T. H. C. Childs., “Consolidation Phenomena in Laser and Powder-Bed Based Layered Manufacturing.” (2007), *CIRP Annals - Manufacturing Technology* 56(2):730–59.
- [11] Zhu, H. H., L. Lu, and J. Y. H. Fuh., “Development and Characterisation of Direct Laser Sintering Cu-Based Metal Powder.” (2003), p. 314–17 in *Journal of Materials Processing Technology*, vol. 140.
- [12] Wu, X., R. Sharman, J. Mei, and W. Voice., “Microstructure and Properties of a Laser Fabricated Burn-Resistant Ti Alloy.” (2004), *Materials and Design* 25(2):103–9.
- [13] Simchi, A. and H. Pohl., “Effects of Laser Sintering Processing Parameters on the Microstructure and Densification of Iron Powder.” (2003), *Materials Science and Engineering A* 359(1–2):119–28.
- [14] Simchi, A. and H. Pohl., “Direct Laser Sintering of Iron-Graphite Powder Mixture.”

- (2004) *Materials Science and Engineering A* 383(2):191–200.
- [15] Additively. "3D Technologies Overview". <https://www.additively.com/en/learn-about/laser-melting>. Retrieved: January 27th 2017.
- [16] Hölker R. Tekkaya A. E., "Advancements in The Manufacturing of Dies for Hot Aluminum Extrusion with Conformal Cooling Channels" (2016), *International Journal of Advanced Manufacturing Technologies*, 83:1209-1220
- [17] Hölker R., Jager A., Khalifa N.B., Tekkaya A.E., "Controlling Heat Balance in Hot Aluminum Extrusion by Additive Manufactured Extrusion Dies with Conformal Cooling Channels" (2013), *International Journal of Precision Engineering and Manufacturing*, (14)8:1487-1493
- [18] Yılmaz F., Koç E., Tekkeşin M., "Production of Metallic Parts by Additive Manufacturing" (2014), Fatih Sultan Mehmet Vakıf University (FSMVU), İstanbul, Turkey
- [19] Yasa E, Kempen K., Kruth J. P., "Microstructure and Mechanical Properties of Maraging Steel 300 After Selective Laser Melting" (2010), Catholic University of Louven, Belgium.
- [20] "EOS M290, The Additive Manufacturing System for the Production of Serial Components, Spare Parts and Functional Prototypes Directly in Metal" (2014), EOS Data Sheet, Munich, Germany

