

Received February 28, 2021, accepted March 10, 2021, date of publication March 15, 2021, date of current version April 8, 2021.

Digital Object Identifier 10.1109/ACCESS.2021.3065939

Designing Deep-Based Learning Flood Forecast Model With ConvLSTM Hybrid Algorithm

MOHAMMED MOISHIN¹, RAVINESH C. DEO¹, (Senior Member, IEEE),
RAMENDRA PRASAD², NAWIN RAJ¹, AND SHAHAB ABDULLA³

¹School of Sciences, University of Southern Queensland–Springfield, Springfield, QLD 4300, Australia

²Department of Science, School of Science and Technology, The University of Fiji, Lautoka, Fiji

³USQ College, University of Southern Queensland, Toowoomba, QLD 4350, Australia

Corresponding authors: Ravinesh C. Deo (ravinesh.deo@usq.edu.au) and Mohammed Moishin (mmoishin@gmail.com)

This work was supported by the Australian Government's Department of Foreign Affairs and Trade through the Australia Awards Scholarship scheme for Fiji under Grant 2020-2021.

ABSTRACT Efficient, robust, and accurate early flood warning is a pivotal decision support tool that can help save lives and protect the infrastructure in natural disasters. This research builds a hybrid deep learning (ConvLSTM) algorithm integrating the predictive merits of Convolutional Neural Network (CNN) and Long Short-Term Memory (LSTM) Network to design and evaluate a flood forecasting model to forecast the future occurrence of flood events. Derived from precipitation dataset, the work adopts a Flood Index (I_F), in form of a mathematical representation, to capture the gradual depletion of water resources over time, employed in a flood monitoring system to determine the duration, severity, and intensity of any flood situation. The newly designed predictive model utilizes statistically significant lagged I_F , improved by antecedent and real-time rainfall data to forecast the next daily I_F value. The performance of the proposed ConvLSTM model is validated against 9 different rainfall datasets in flood prone regions in Fiji which faces flood-driven devastations almost annually. The results illustrate the superiority of ConvLSTM-based flood model over the benchmark methods, all of which were tested at the 1-day, 3-day, 7-day, and the 14-day forecast horizon. For instance, the Root Mean Squared Error (RMSE) for the study sites were 0.101, 0.150, 0.211 and 0.279 for the four forecasted periods, respectively, using ConvLSTM model. For the next best model, the RMSE values were 0.105, 0.154, 0.213 and 0.282 in that same order for the four forecast horizons. In terms of the difference in model performance for individual stations, the Legate-McCabe Efficiency Index (LME) were 0.939, 0.898, 0.832 and 0.726 for the four forecast horizons, respectively. The results demonstrated practical utility of ConvLSTM in accurately forecasting I_F and its potential use in disaster management and risk mitigation in the current phase of extreme weather events.

INDEX TERMS ConvLSTM, deep learning, flood forecasting, flood index, flood risk management.

I. INTRODUCTION

Early detection of natural disasters such as floods can greatly assist humans in reducing the extent of the damage caused by such events. In the Fiji Islands, where this study is focused, recent flood events resulted in major damages amounting to millions of dollars [1]. The loss of at least 225 lives during the 1931 flood event in Fiji was primarily due to the unavailability of efficient flood warning systems [2]. Although there have been improvements in early warning systems since then, many other emerging technologies, which are somewhat constrained in developing nations, have strong potential to deliver

robust and cost-effective solutions for disaster risk and flood event management.

One simple, yet a robust mathematical tool used to determine the flood state at a particular time for a given area is the Flood Index (I_F) [3]. This approach represents the standardized form of 'Effective Precipitation' (P_E) based on the rationale that a flood event on any particular day is dependent on the current and the previous day's precipitation with the effect of previous day's precipitation on current day's flood state gradually reducing due to the effect of hydrological factors [4]. I_F has been applied at various locations globally and is generally accepted as an accurate data-driven mechanism to monitor flood state and, to determine the duration, severity, and intensity of flood situations [5]–[8]. However, as a flood monitoring index, I_F cannot be currently used to determine

The associate editor coordinating the review of this manuscript and approving it for publication was Bo Pu.

the flood state ahead of time unless a predictive model for this index is built and tested. If a model is successful in predicting the flood event, the exploration of its predictive skill for multiple forecast horizons is paramount so that early warning of the flood state can be disseminated, setting up flood risk mitigation and adaptation measures. This is the subject of the present research paper.

To make practical use of I_F in forecasting future flood situations, an Artificial Intelligence (AI) based predictive model can be developed to accurately forecast the future values of I_F based on antecedent (lagged) values over a given period. Notably, AI models have shown good potential in forecasting floods based on metrics other than I_F , with continuous improvement in AI-based methods over the past decade. A study on classifying flood severity based on weather radar and rainfall data showed that Artificial Neural Network (ANN) which is an AI-based machine learning algorithm, had good potential to deliver major improvement in the speed compared with conventional hydraulic simulators [9]. A more recent AI approach that uses representation learning with several levels of feature representation is deep learning [10]. One popular deep learning approach used for time-series forecasts is Long Short-Term Memory Network (LSTM) [11]. LSTM is a type of Recurrent Neural Network (RNN) that can address the vanishing gradient problems in RNNs [12]. This approach has been applied in applications e.g., short-term fog forecasting and language processing [13], [14]. When LSTM was compared with ANN, the former performed better and was relatively stable to simulate rainfall-runoff process [15]. Therefore, when compared with conventional machine learning algorithms such as ANN, deep learning LSTM seems to be a better option to forecast flood events especially using time-series flood monitoring data, such as the current research using I_F .

In AI-based methods, multiple deep learning models are normally integrated to deliver a better performance accuracy. One common model known to provide effective performance when combined with LSTM is Convolutional Neural Network (CNN) [16]. In Liu, *et al.* [17], a ConvLSTM module was used to predict short-term traffic flow, combining convolution and LSTM models, outperforming the benchmark models. ConvLSTM was applied for precipitation nowcasting to show excellent performance [18]. These studies generally illustrate the good performance of ConvLSTM compared with others in similar machine learning problems. It is thus expected that ConvLSTM may deliver a better performance in forecasting future flood events using daily I_F and rainfall data but no previous study has built this approach into real-time, multiple-step flood prediction problems.

As an AI-based deep learning model has not been used to forecast floods using I_F , this novel technique adopted to forecast the occurrence of future events is expected to provide an alternative to traditional mathematical means such as using the Standardized Precipitation Index (SPI) for early flood warnings [19]. The cost-effectiveness and accuracy of deep learning approaches explored in this paper, is also expected

to provide a suitable tool for efficient flood forecasting in developing and developed nations.

By making significant contribution to disaster risk mitigation, the purpose of this article is to design an AI-based predictive model trained as a practical and highly accurate tool in forecasting the onset of flood state using daily I_F and precipitation data. The research objectives, which advance the application of data-driven methods, make significant contributions to flood forecasting and mitigation, as follows:

(1) Build flood monitoring and validation system by deriving daily I_F from rainfall data obtained from Fiji Meteorological Service at nine flood-prone sites in Fiji over a 30-year period.

(2) Develop multi-step predictive model using ConvLSTM, as an objective model, with alternative methods of LSTM, CNN-LSTM and SVR that can also determine the flood state at 1-day, 3-day, 7-day, and 14-day forecast horizons.

(3) Evaluate the performance of predictive models using a diverse range of statistical score metrics, infographics, and visual analysis of forecasted and ground-truth dataset.

(4) Compare the evaluation results of objective model with benchmark models and elaborate on the suitability of the ConvLSTM model in accurately forecasting future flood situations.

The structure of the paper is as follows. In next section, the related works are presented. Then in section 3 this research presents the problem and motivation for this study and a theoretical overview of ConvLSTM and I_F . In section 4, this study presents experimental methods where the study area and data used for this study are presented briefly. Next, the method employed to develop flood forecast models are explained. After this, the results are presented, and this is followed by the discussion of the limitations, practicality, and contributions of the proposed method. Finally, the paper concludes by presenting insights from this study.

II. RELATED WORKS

Over the years, several data-driven early flood forecasting systems have been developed. These have made use of machine learning algorithms to develop models that show promising results. Some of these studies are presented in this section.

In one of the earliest examples, Campolo, *et al.* [20] developed a neural network river flood forecasting model illustrating promising results at short timescales. However, a rapid decrease in forecasting performance was evident with a longer time horizon. Another short-term flood forecasting approach was presented by Nayak, *et al.* [21] using neuro-fuzzy technique. The results illustrated the viability of their models for short-term river flow forecasting. Moving on, Han, *et al.* [22] applied Support Vector Machine (SVM) for flood forecasting. However, they mentioned that although their objective model performed better than the benchmark models, it required considerable amount of efforts to ensure the better performance of the objective model

Sit and Demir [23] explored the use of artificial deep neural networks for flood prediction and mentioned the usefulness of neural networks for flood forecasting using time-series data.

The approaches presented so far have made use of conventional machine learning to forecast flood situations. A study by Tran and Song [24], however, used deep learning algorithms i.e., RNN and LSTM to forecast water levels as a practical means to develop a solution for flood forecasting in urban areas. Their results indicated that all deep learning models had high accuracy. Therefore, in this paper, hybrid deep learning approaches are used to forecast floods at both short and long timescales, expecting that these newly developed models are a step forward in data-driven-based early flood warning systems.

III. METHODOLOGY

A. PROBLEMS AND MOTIVATIONS

Owing to the insidious and ‘creeping’ nature of flood events, designing robust systems for early flood warnings is a challenge. This is because the design of early warning systems requires expertise in different technologies [25]. It is understandable that this could be a bigger challenge for developing nations e.g., Fiji. Therefore, a cost-effective solution that requires a minimum investment in such technologies is desirable for flood forecasting purposes. The new flood modeling method presented in this research will address these problems. A data-driven model that requires only the daily rainfall data to deliver an accurate result is expected to be a cost-effective solution for nations with limited resources where technological advancements has not penetrated yet. Furthermore, another motivation behind this study is the recurrent destructions that flood events have caused in the present study area over many years. Through this study, the authors hope to develop and validate a new flood forecasting model that can be used to mitigate the impact of floods not only in island nations but also elsewhere by enabling the people and organizations to be better prepared for future flood events.

B. THEORETICAL OVERVIEW

To date, there are only a handful of flood monitoring indices that can determine the flood state for any day based on antecedent day’s rainfall [3], [26]. These are categorised into data-driven mathematical models and have generally been accepted to produce accurate results. As mentioned previously, I_F is adopted for this study as it conforms to the rationale of Lu [26]. Basically, I_F uses current and antecedent day’s rainfall data to determine the flood state of current day. The contributory influence of previous day’s precipitation on current day’s possibility of a flood decreases gradually in agreement with a time-dependent reduction function. Through this, the flood index can account for the loss of water due to hydrological factors e.g., evaporation, percolation, evapotranspiration and surface run-off [3]. This makes the flood index a practical tool to determine the flood state solely using daily rainfall data that is advantageous in regions

without sophisticated flood monitoring technologies. In a previous paper, I_F applied in Fiji was shown to be an effective tool for flood monitoring at short timescales [7]. In many other related works [4]–[6], [27], [28], I_F has already been adopted for flood monitoring studies but none of these studies have built a deep learning forecast model using the I_F . Hence I_F -based data-driven models trained over multiple forecast horizons, as undertaken in this study, is a proactive step in estimating the flood extent of any day-ahead period, based on which flood risk mitigation and disaster response can be implemented.

The objective model in this study adopts hybrid ConvLSTM algorithm, a dual combination of deep learning method. ConvLSTM is a hybrid variant of LSTM architecture that uses convolutional operators instead of matrix multiplication for its input to the state and the state-to-state transition. This enables the algorithm to handle spatiotemporal data and determine the upcoming state(s) of a particular cell in grids using local neighbours’ inputs and previous states [18]. Equations 1 to 5, retrieved from earlier studies of Medel [29] and Xingjian, *et al.* [18], expresses the operational mechanisms of ConvLSTM. In these equations, ‘*’ and ‘o’ denotes convolution operator and Hadamard product, respectively. The i , f and o represents each timestamp’s input, forget and output gates, separately. H denotes each timestamp’s hidden state, C represents each timestamp’s cell outputs, and X denotes all the inputs. The activation is denoted by σ while W is used to denote the weighted connections between the states.

$$i_t = \sigma (W_{xi} * X_t + W_{hi} * H_{t-1} + W_{ci} \circ C_{t-1} + b_i) \quad (1)$$

$$f_t = \sigma (W_{xf} * X_t + W_{hf} * H_{t-1} + W_{cf} \circ C_{t-1} + b_f) \quad (2)$$

$$C_t = f_t \circ C_{t-1} + i_t \circ \tanh (W_{xc} * X_t + W_{hc} * H_{t-1} + b_c) \quad (3)$$

$$o_t = \sigma (W_{xo} * X_t + W_{ho} * H_{t-1} + W_{co} \circ C_t + b_o) \quad (4)$$

$$H_t = o_t \circ \tanh (C_t) \quad (5)$$

Theoretical explanations of benchmark models, LSTM [30], CNN-LSTM [31] and SVR [32] (Support Vector Regression), are available in studies elsewhere.

C. OVERVIEW OF THE PROPOSED PREDICTIVE MODEL

In previous sub-sections, an overview of I_F and ConvLSTM is provided. In this section the overall architecture of the proposed model is presented. As evident in Figure 1, the main information needed to build the predictive model is daily rainfall. The antecedent raw rainfall data and rainfall derived, daily I_F data are used as two inputs to the selected algorithm. The algorithm is used to forecast I_F for 1-, 3-, 7- and 14-day forecast horizons.

IV. EXPERIMENTS

A. STUDY AREA

The focus of this study is on towns and cities in Fiji. The Fiji group covers an area of 18,270 km² in the South Pacific Ocean [33]. Fiji has an oceanic tropical climate with the South Pacific Convergence Zone (SPCZ) having a strong influence

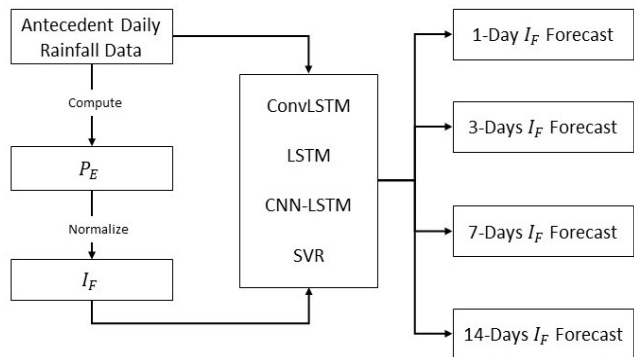

FIGURE 1. Overview of proposed experimental architecture.

on the climate of this small island nation [34]. The wet season in Fiji is usually between November and April and during this time, the SPCZ is positioned over Fiji. As heavy rain is experienced during this time, this results in regular flood situations around the flood prone areas in the country [35]. This study covers nine towns and cities from the two largest islands in Fiji. These are Viti Levu and Vanua Levu and they have an area of 10,400 and 5,540 km², respectively [34]. As seen in Figure 2, due to the small area of the Fiji group, this study has covered most of the major towns and cities of the archipelagic nation.

B. DATASET

The daily rainfall data for eleven sites from 1st January 1990 to 31st December 2019 (30 Years) was successfully acquired from Fiji Meteorological Services. These sites are illustrated in the map from Figure 2. During data pre-processing, the following actions were taken for simpler computations and more accurate results. Firstly, calendar mean was used to fill in the values for missing data points. Two sites, Navua and Tavua, which had high proportion of missing values, were excluded.

These two sites did not record precipitation for extended duration of the study period. For leap year the rainfall for 29th of February was added to 1st March following other works [6], [27], [28]. This resulted in all years having 365 data points to facilitate the computation of *I_F*. To visualize, in Figure 3, the trend of precipitation using data from Ba site over a 30-year period is presented.

C. FLOOD INDEX COMPUTATION

The computation of *I_F* and relevant metrics associated with *I_F* was performed using MATLAB [36] software. In computing the *I_F*, the first step was to obtain Effective Precipitation (*P_E*) [4]. The mathematical formula used to obtain the *P_E* is presented in equation 6. In this equation, *N* is the duration of antecedent period and *P_m* is the recorded precipitation for day *m*. *P_E* accounts for the depleting earlier days precipitation using a time-dependent reduction function. Moving on, once the *P_E* is computed, it can be used to get the Available Water Resource Index (*AWRI*) [37]. The *AWRI* is obtained simply

by dividing the *P_E* over the accumulative weight (*W*) of the antecedent period and this is shown in equation 7. Next, the *I_F* is calculated [3]. As shown in equation 9, *I_F* is the standardized version of *P_E*. In this equation, $\sigma_{1991}^{(2019} P_E^{\bar{m}max})$ and $\frac{2019 P_E^{\bar{m}max}}{1991}$ denote the standard deviation and mean of the yearly maximum daily *P_E* during the study period. The duration, severity and intensity of floods can be successively determined using equations presented in earlier studies [7].

$$P_{E_i} = \sum_{N=1}^D \left[\frac{\sum_{m=1}^N P_m}{N} \right] \quad (1 \leq m \leq 365) \quad (6)$$

$$AWRI = \frac{P_E}{W} \quad (7)$$

$$W = \sum_{n=1}^{n=D} \frac{1}{n} \quad (8)$$

$$I_F = \frac{P_E - \frac{2019 P_E^{\bar{m}max}}{1991}}{\sigma_{1991}^{(2019} P_E^{\bar{m}max})} \quad (9)$$

D. PREDICTIVE MODEL DESIGN

To develop an AI-based flood forecast model, Python [38] programming language was used. As Python offers an efficient environment for machine learning data analysis, it was selected to design the forecast model [39]. Some machine learning packages for Python included Scikit-Learn [40], Tensorflow [41] and Keras [42], as these are popular packages solving machine learning problems that have also been used in previous studies to build efficient forecast models [43]. The scope of this study was to develop flood-forecasting models using deep ConvLSTM models and to compare the suitability of the algorithm in forecasting of flood situations using daily *I_F*.

Prior to data pre-processing, analysis of available data was done. The *I_F* for all the nine study sites were analysed. Firstly, the D’Agostino’s K² Test (DKT) [44] was done to perform the statistical normality (or otherwise) test. The results showed that none of the data were Gaussian. Next, the Dickey-Fuller Test (DFT) [45] was performed to test for stationarity in data. The *I_F* data were stationary for all study sites. The next step for data analysis was to figure out the number of lag inputs that would be significant for the time-series forecasting. Partial Autocorrelation Function (PACF) was used for this purpose. After the impact of other variables are eliminated, the supplementary information given by lagged data is explained by PACF [46]. As seen in Table 1, two and three days of lagged inputs were significant for five and four study sites, respectively. This table also presents the results of other data analysis.

In the data pre-processing stage, the data was divided into training, validation, and testing subsets. 29 years (10,585 data points at daily time-steps) of *I_F* were calculated for each study site. The features used as model inputs included antecedent *I_F* and precipitation. 80% of these data were assigned for model training with 20% of the training data used for model validation purposes. The remaining data were used for testing the model’s implementation. As there is no specific rule for

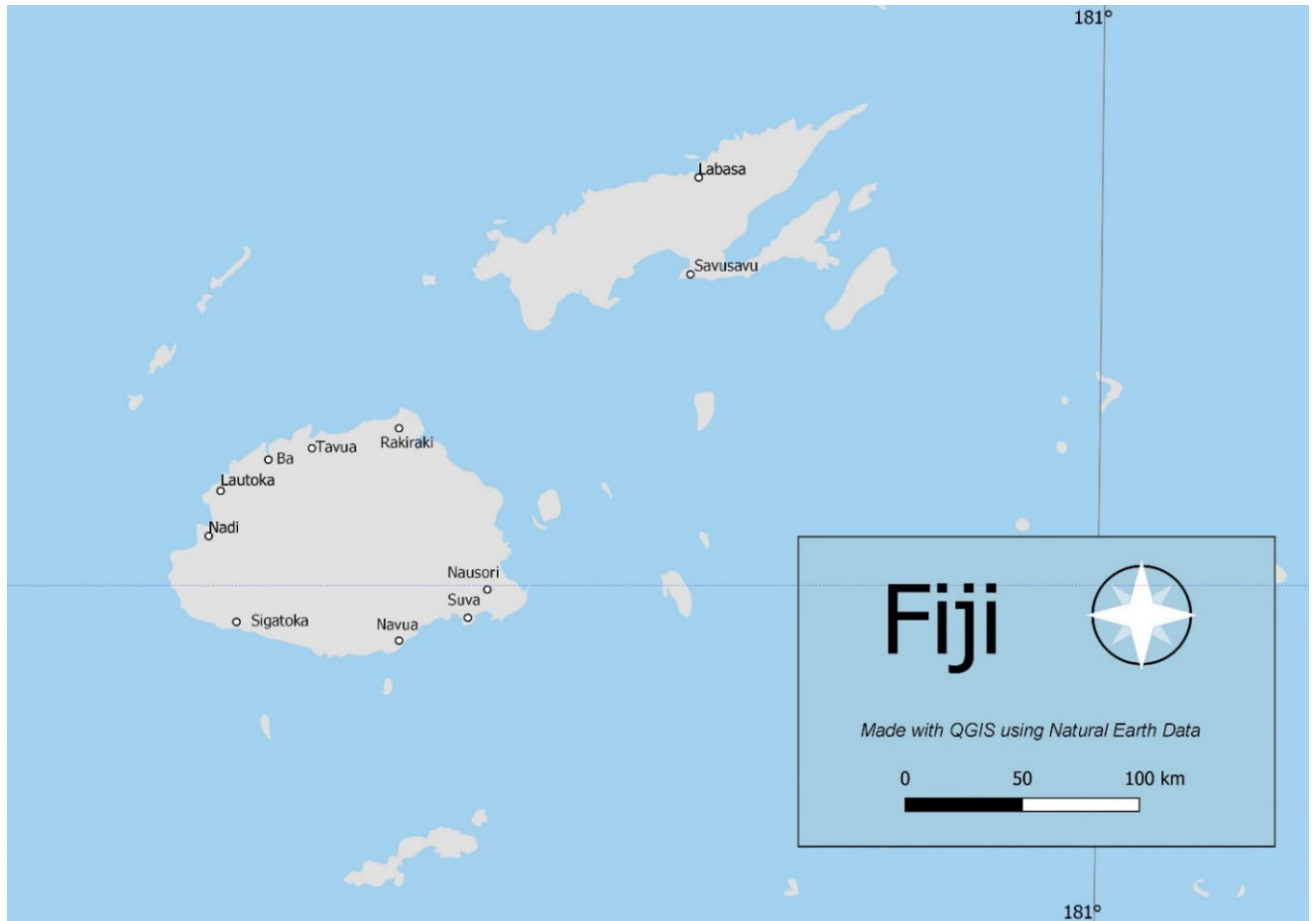

FIGURE 2. Map of the Fiji Islands showing study sites where the ConvLSTM model was developed.

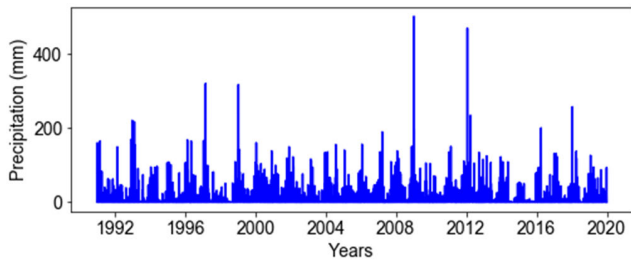

FIGURE 3. Daily Rainfall for the study site (Ba) over 1991 to 2019.

TABLE 1. Results from statistical tests.

Flood Site	Gaussian?	Stationary?	95% significant lagged IF
Ba	No	Yes	3
Labasa	No	Yes	3
Lautoka	No	Yes	2
Nadi	No	Yes	2
Nausori	No	Yes	2
Rakiraki	No	Yes	3
Savusavu	No	Yes	2
Sigatoka	No	Yes	2
Suva	No	Yes	3

the splitting ratio, the study adopted 80% for training data based on a study that used a similar ratio [47]. To verify this ratio, the effect of having 10%, 20% and 30% of data in the testing set was later compared. Upon comparison, all three ratios had relatively similar performance, and this verified the adoption of 20% of data as testing data during the experiments.

The ConvLSTM model type used for the experiment was Multiple Input Multi-Step Output model [48]. As more than one feature was to be used as input and the model had to forecast I_F at multiple forecast horizons, the Multiple Input

Multi-Step Output model was determined to be the most suitable for this use case. The data were first structured to make them appropriate for Multiple Input Multi-Step Output supervised learning. Input feature set consisted of I_F and P at $t - 1$ and the target consisted of I_F at t . After this, all variables in these data were scaled between [0, 1]. Scaling these data before running the model led to an improvement in speed and accuracy during training and testing phases. Next, the data were reshaped to the format to be accepted by the predictive model. This shape was adjusted based on forecast horizon for which the model was being built for and

TABLE 2. Optimal parameters of the developed model.

Predictive Model	Parameter Names	Optimal Parameters
ConvLSTM	Filter 1	128
	Activation	ReLU
	Optimizer	Adam
	Batch Size	100
	Epochs	50
CNN-LSTM	Filters	128
	Max Pooling 1D	Pool Size = 2
	LSTM Cell	50
	Activation	ReLU
	Optimizer	Adam
	Batch Size	100
	Epochs	50
LSTM	LSTM Cell 1	100
	LSTM Cell 2	50
	Activation	ReLU
	Optimizer	Adam
	Batch Size	100
	Epochs	50
SVR	Kernel	rbf
	degree	3 (Default)
	Gamma	Scale

TABLE 3. Architecture of the deep learning models.

Model	ConvLSTM	CNN-LSTM	LSTM
Layer 1 (L1)	128 Filters	128 Filters	100
L1 Type	ConvLSTM2D	Conv1D	LSTM
L1 Activation	ReLU	ReLU	ReLU
Layer 2 (L2)	-	Pool Size – 2	50
L2 Type	Flatten	MaxPooling1D	LSTM
L2 Activation	-	-	ReLU
Layer 3 (L3)	-	-	-
L3 Type	Dense	Flatten	Dense
Layer 4 (L4)	-	50	-
L4 Type	-	LSTM	-
L4 Activation	-	ReLU	-
Layer 5 (L5)	-	-	-
L5 Type	-	Dense	-

the number of lagged days considered. Once the data was prepared, the models were trained using different combinations of hyperparameters. These combinations of parameters were adjusted manually until the most optimal set of hyperparameters were attained. As the same set of parameters were the most optimal for all sites and horizons, this assisted in a more effective comparison of the performance of the models at different forecast horizons.

Table 2 presents optimal parameters of all models. Table 3 shows the architecture of deep learning models. The objective model, ConvLSTM consisted of three feature layers. The first was a ConvLSTM2D layer with 128 filters and rectified linear unit (ReLU) as the activation function. The second layer was a flattening layer, and the final layer

was a dense layer. As the inputs consisted of only two features, this simple configuration was enough to achieve the optimal model. Furthermore, a batch size of 100 was chosen, with Adam as the optimizing algorithm.

Several statistical metrics were used for thorough evaluation of models developed in this study. These performance metrics included Root Mean Squared Error (RMSE), Pearson’s Correlation Coefficient (r), Mean Absolute Error (MAE), Coefficient of Determination (r²), Willmott’s Index (Index of Agreement; d), Nash-Sutcliffe Efficiency Index (NSE), and Legate-McCabe Efficiency Index (LME). Apart from Sci-Kit Learn, two other Python packages, HydroEval [49] and HydroErr [50] were used to apply these performance metrics. The mathematical representation of these metrics is presented from Equations 10 to 15, respectively.

$$RMSE = \sqrt{\frac{\sum_{i=1}^n (S_i - O_i)^2}{n}} \tag{10}$$

$$r = \frac{\sum_{i=1}^n (O_i - \bar{O})(S_i - \bar{S})}{\sqrt{\sum_{i=1}^n (O_i - \bar{O})^2} \sqrt{\sum_{i=1}^n (S_i - \bar{S})^2}} \tag{11}$$

$$MAE = \frac{1}{n} \sum_{i=0}^n |S_i - O_i| \tag{12}$$

$$d = 1 - \frac{\sum_{i=1}^n (S_i - O_i)^2}{\sum_{i=1}^n (|S_i - \bar{O}| + |O_i - \bar{O}|)^2} \tag{13}$$

$$NSE = 1 - \frac{\sum_{i=1}^n (S_i - O_i)^2}{\sum_{i=1}^n (O_i - \bar{O})^2} \tag{14}$$

$$LME = 1 - \frac{\sum_{i=1}^n |S_i - O_i|}{\sum_{i=1}^n |O_i - \bar{O}|} \tag{15}$$

where S is the forecasted value of I_F , \bar{S} is the mean of the forecasted values of I_F , O is the observed value of I_F and \bar{O} is the mean of the observed values of I_F .

E. RESULTS

This section presents the results of performance evaluation of AI-based models (ConvLSTM, CNN-LSTM, LSTM and SVR) adopted to forecast future flood situations in Fiji, and these are shown for different flood forecasting periods (i.e., 1-day, 3-day, 7-day, and 14-day). The evaluation results from four forecast horizons and nine study sites expectedly verifies the robustness of the objective ConvLSTM model in forecasting future flood situations. The results are aggregated to enable the paper to deliver an extensive comparative outcome for all locations and forecast horizons.

To begin with, the results from the nine sites were averaged so that the performance of the models can be easily compared. The performance evaluation of the models using RMSE and MAE is presented in Table 4. It can be clearly seen from this table that ConvLSTM demonstrated the minimum errors when compared with the benchmark models for all the four forecast horizons. In addition, as expected, the error measure increases as the forecasting period increases. For instance, the average RMSE for 1-day forecasting using ConvLSTM

TABLE 4. The performance of ConvLSTM with benchmark models in terms of average RMSE and MAE for nine sites for 1-day, 3-day, 7-DAY, and 14-day flood forecasting.

Models	RMSE			
	1 Day	3 Day	7 Day	14 Day
ConvLSTM	0.101	0.150	0.211	0.279
LSTM	0.105	0.154	0.213	0.282
CNN-LSTM	0.126	0.169	0.225	0.290
SVR	0.350	0.348	0.351	0.369
Models	MAE			
	1 Day	3 Day	7 Day	14 Day
ConvLSTM	0.048	0.077	0.118	0.172
LSTM	0.058	0.090	0.131	0.185
CNN-LSTM	0.064	0.094	0.135	0.187
SVR	0.340	0.332	0.323	0.324

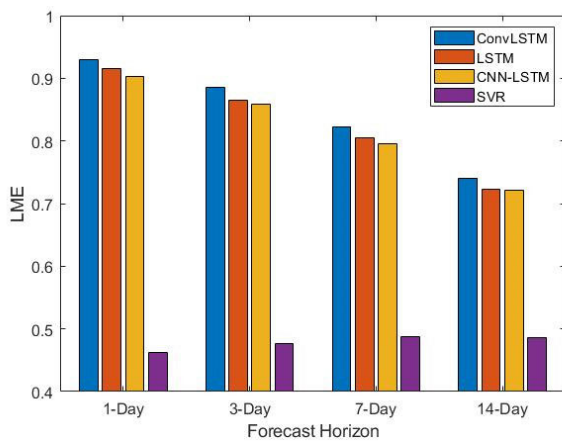

FIGURE 4. The performance of ConvLSTM with benchmark model in terms of average LME for nine sites for 1-day, 3-day, 7day and 14-day Flood Forecasts.

was 0.101, whereas for 14-days, it was 0.279. Similar trend is seen with MAE. Therefore, based on RMSE and MAE measures, the performance of ConvLSTM for flood forecasting is the optimal. This is followed by LSTM, CNN-LSTM and SVR.

In accordance with Equation (15) LME was used to evaluate the accuracy of models. Figure 4 illustrates average LME for all sites at all forecast horizons. Again, these results clearly demonstrated the better performance of ConvLSTM. The performance of the objective model is significantly better than the other models for all the forecast horizons. However, like error measures, the accuracy of all the models decrease as the forecast horizons is extended to 14-days. Also, after ConvLSTM, the best performing models in terms of LME were LSTM, CNN-LSTM and SVR, respectively. As seen in Figure 4, for the benchmark models, LSTM and CNN-LSTM’s performance were reasonable but the performance of SVR was below 0.5 for all the forecast horizons.

In addition to the results from the aggregated data being used to show the show the performance of the four algorithms at the four forecast horizons, the LME analysis for Rakiraki site is presented in Table 5 to compare if the

TABLE 5. Comparing the performance of ConvLSTM with the benchmark models in terms of LME for Rakiraki site for 1-day, 3-day, 7-DAY, and 14-day flood forecasting.

Models	LME			
	1 Day	3 Day	7 Day	14 Day
ConvLSTM	0.939	0.898	0.832	0.726
LSTM	0.927	0.891	0.827	0.707
CNN-LSTM	0.881	0.830	0.768	0.711
SVR	0.407	0.409	0.414	0.407

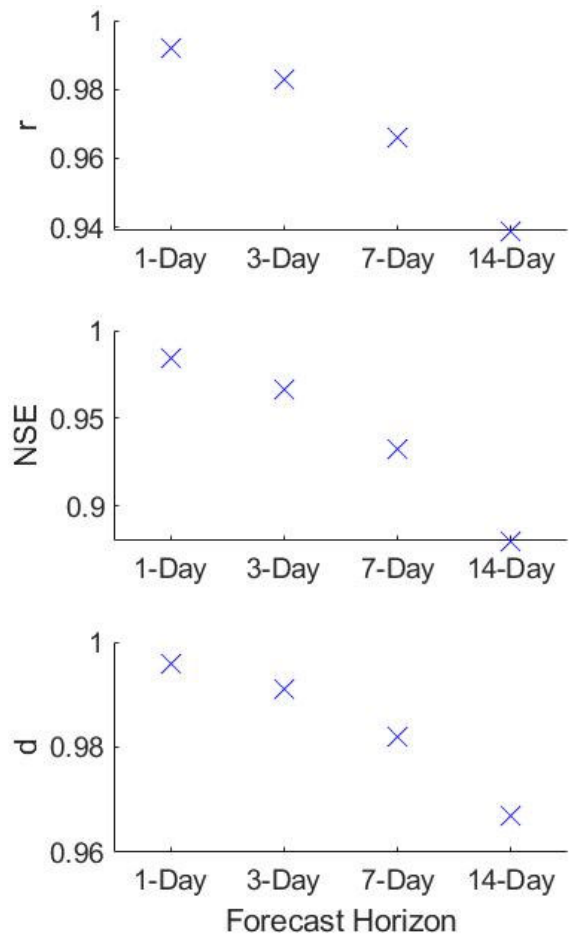

FIGURE 5. Evaluating the performance of ConvLSTM using average r, NSE and d values for 1-day, 3-day, 7-day and 14-day Flood Forecasting.

model performances are similar with non-aggregated data. This table shows similar trends in performance as with the aggregated data whereby ConvLSTM performs the best for all forecast horizons, followed by LSTM, CNN-LSTM and SVR. Also, as the forecast horizons increases, the performance accuracy drops. As the trends and measures with the non-aggregated data is close to the aggregated data, it verifies the use of aggregated data when presenting the performance evaluation results.

Based on the previous results, it can be clearly established that ConvLSTM performs the best out of the four models.

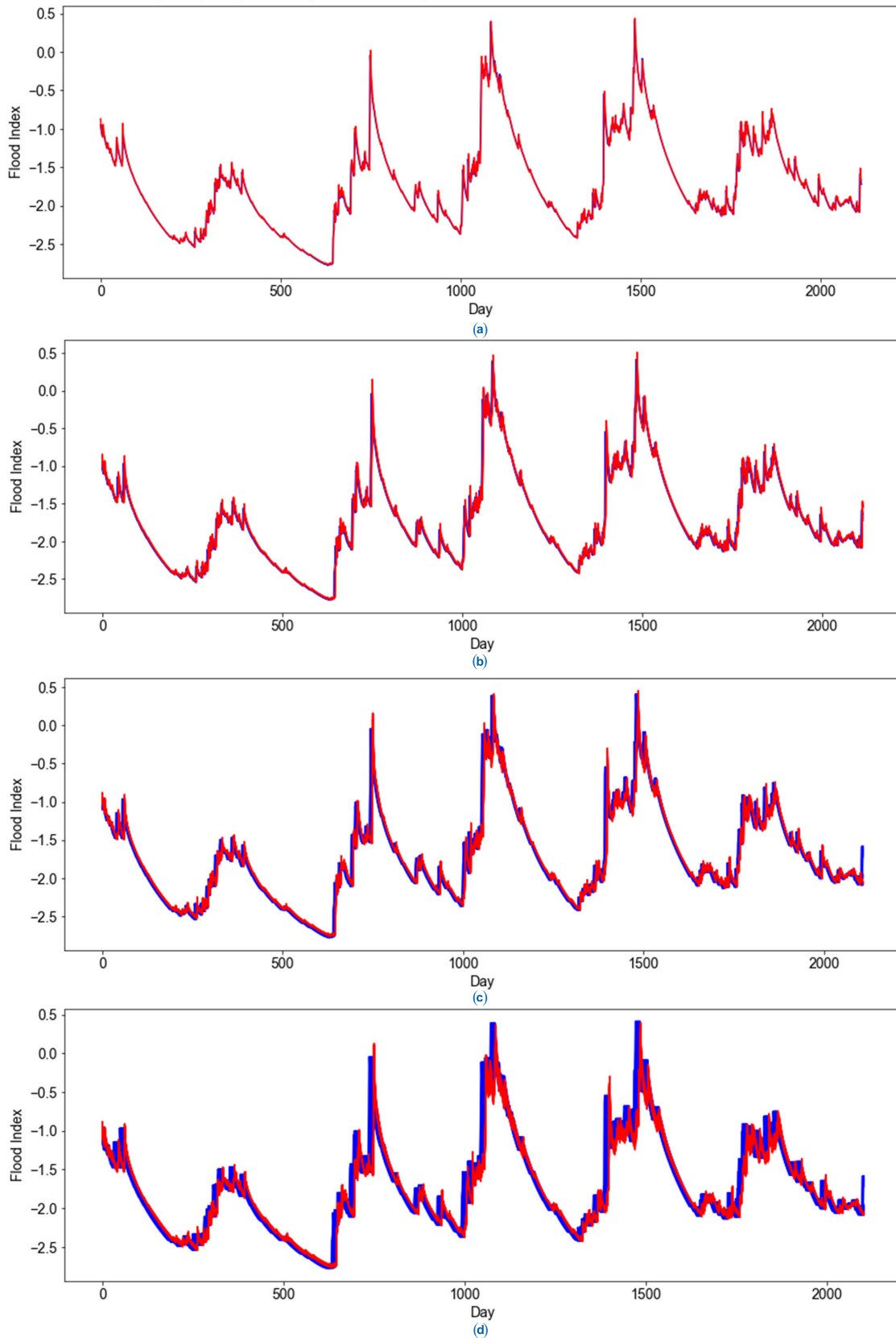

FIGURE 6. (a) Actual versus 1 -day forecasted I_F for Ba Site using ConvLSTM. (b) Actual versus 3-day forecasted I_F for Ba Site using ConvLSTM. (c) Actual versus 7 -day forecasted I_F for Ba Site using ConvLSTM. (d) Actual versus 14 -day forecasted I_F for Ba Site using ConvLSTM.

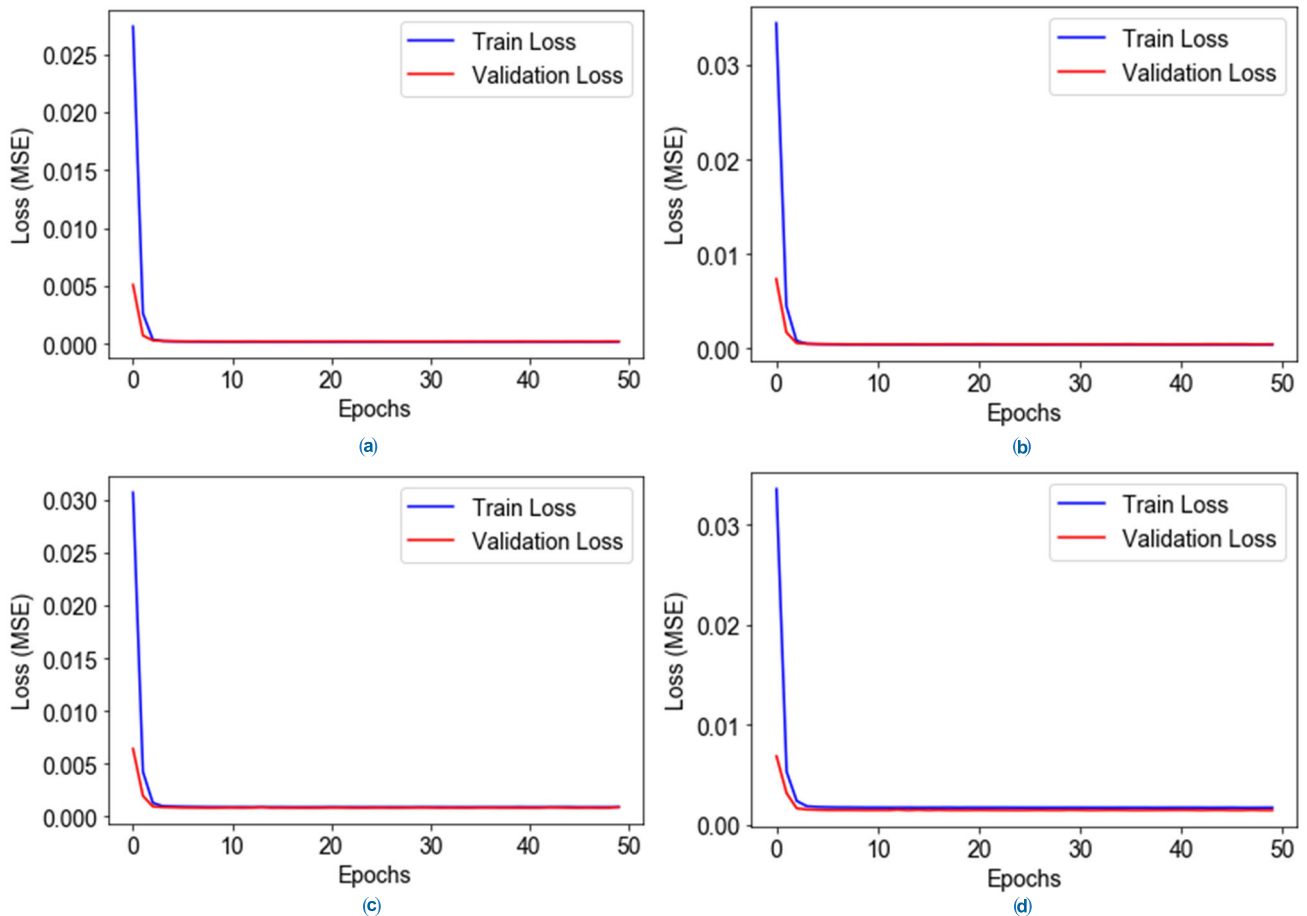

FIGURE 7. (a) Model Loss for 1-Day I_F Forecasting using ConvLSTM for Ba Site. (b) Model Loss for 3-Day I_F Forecasting using ConvLSTM for Ba Site. (c) Model Loss for 7-Day I_F Forecasting using ConvLSTM for Ba Site. (d) Model Loss for 14-Day I_F Forecasting using ConvLSTM for Ba Site.

Next, r , NSE and d were used to further evaluate the performance of ConvLSTM for flood forecasting. As seen in Figure 5, for all the forecast horizons, the measures of r , NSE and d were greater than 0.93, 0.85 and 0.95, respectively. This clearly shows that ConvLSTM can be used to forecast I_F at longer timescales without a significant impact on its performance. Considering that only two features are used for building the forecasting model, these results illustrated the good performance of the model despite the usage of few variables.

Moving on, Figures 6 a-d shows the graphical view of 1-day, 3-day, 7-day, and 14-day I_F forecasting using testing results from Ba site and ConvLSTM algorithm. This view assists in understanding how close the forecasted values of I_F are with the actual values. As the forecast horizons increase, the difference in the forecasted and actual values of I_F also increased. However, even with this increase, the graphs clearly illustrate that the forecasted results are very close to the actual I_F for all the forecast horizons.

Finally, the model loss in terms of Mean Squared Error (MSE) during training and validation of the ConvLSTM for 1-day, 3-day, 7-day and 14-day flood forecasting using data from Ba site is presented in Figures 7 a-d, respectively.

As seen in these figures, the models achieve minimum training and validation losses in less than 5 epochs. This is potentially due to only two features being used for the forecasting task. This further affirms the results, which showed good performance of the ConvLSTM model. Despite having only two input features, the proposed hybrid deep learning I_F forecasting model, i.e., ConvLSTM, provided very good forecasting performances at four forecasting horizons that can serve as the core of an early flood warning system.

F. DISCUSSION

The results presented in the previous section illustrate the feasibility of the ConvLSTM based I_F forecasting model to determine the possibility of flood situations at 1, 3, 7 and 14 day ahead forecast horizons. In this section, the limitations, restrictions, and recommendations for future research regarding the proposed flood forecast system is presented.

To begin with, one of the major limitations of this study is that the predictive model that was developed during this research only used two input features. Even though, only two features were used, good forecasting performance was achieved, it is expected that adding more useful features as input will assist in developing a more robust model with

better forecasting accuracy at extended forecast horizons. It is recommended in future studies, that the model is enhanced by identifying and applying additional relevant features.

Another limitation of the study is in terms of the I_F . I_F has been previously applied in Fiji and has shown suitability as a means of quantifying floods [7]. Therefore, it was acceptable to develop I_F based forecasting system for Fiji. However, for areas where the suitability of I_F has not been established yet, the forecasting method presented in this paper may not be appropriate for those areas. It is recommended that during the application of the proposed method in new study areas the suitability of I_F for that location should be evaluated before the development of the forecasting model.

Furthermore, another limitation is in terms of applying the proposed model at the study site for regular flood forecasting. Even though it is expected that the model can be easily incorporated into the workflow replacing classical forecasting techniques, the major challenge surrounding this would be regularly obtaining accurate data and finding expertise to implement these advanced techniques in the relevant organizations. Therefore, it is recommended that in future research more user-friendly tools for flood forecasting be developed and other deep learning and machine learning algorithms be tested for I_F forecasting. The results from this research can be set as a comparison benchmark for the newly build models.

V. CONCLUSION

In this paper, a hybrid deep learning based flood forecasting approach was presented. This novel approach made use of daily lagged I_F and precipitation time series data to determine flood situations at multiple forecast horizons. The practicality of the model was tested using datasets from nine locations in Fiji. Among the deep learning models evaluated, ConvLSTM, which was the objective model showed the best performance. The following are the main contributions of this paper:

1. This research was the first to use I_F with a hybrid deep learning algorithm to develop an AI-based model for flood forecasting.
2. The robustness of the objective model, ConvLSTM, was presented during this research whereby it illustrated better performance when compared with deep learning (LSTM and CNN-LSTM) and machine learning models (SVR) for 1-day, 3-day, 7-day and 14-day flood situation forecasting using datasets from nine sites.
3. Using various statistical score metrics, the accuracy of the model for multi-step flood situation forecasting was clearly established.
4. The application of the model at various sites in Fiji illustrated the practicality of the approach in accurately forecasting floods at multiple timescales in a cost-effective manner.

To conclude, the approach presented in this paper could be further enhanced to forecast flood situations at hourly time scales. Accurate forecasting at shorter timescales is expected to result in more time for informed decision making by governments, organizations, and individuals to be better prepared

for flood situations and therefore saving lives and protecting infrastructure resources.

ACKNOWLEDGMENT

Mohammed Moishin is an Australia Awards Scholar supported by the Australian Government. He is grateful to the Australian Department of Foreign Affairs and Trade for funding this study through the Australia Awards Scholarship scheme 2020–2021. Disclaimer: The views and opinions expressed in this article are those of the authors and do not represent the views of the Australian Government. The authors would like to thank Fiji Meteorological Service for providing the rainfall data required for this project.

REFERENCES

- [1] P. Brown, A. Daigneault, and D. Gawith, "Climate change and the economic impacts of flooding on fiji," *Climate Develop.*, vol. 9, no. 6, pp. 493–504, Sep. 2017, doi: [10.1080/17565529.2016.1174656](https://doi.org/10.1080/17565529.2016.1174656).
- [2] S. W. Yeo and R. J. Blong, "Fiji's worst natural disaster: The 1931 hurricane and flood," *Disasters*, vol. 34, no. 3, pp. 657–683, Jul. 2010.
- [3] R. C. Deo, H.-R. Byun, J. F. Adamowski, and D.-W. Kim, "A real-time flood monitoring index based on daily effective precipitation and its application to brisbane and lockyer valley flood events," *Water Resour. Manage.*, vol. 29, no. 11, pp. 4075–4093, Sep. 2015, doi: [10.1007/s11269-015-1046-3](https://doi.org/10.1007/s11269-015-1046-3).
- [4] H.-R. Byeon and J.-S. Jeong, "Quantified diagnosis of flood possibility by using effective precipitation index," *J. Korea Water Resour. Assoc.*, vol. 31, no. 6, pp. 657–665, 1998.
- [5] R. C. Deo, H. R. Byun, J. F. Adamowski, and D. W. Kim, "Diagnosis of flood events in Brisbane (Australia) using a flood index based on daily effective precipitation," in *Proc. Int. Conf., Anal. Manage. Changing Risks Natural Hazards, Eur. Commission, 7th Framework Programme, Marie Curie Actions*, 2014, p. AP20-1.
- [6] R. C. Deo, J. F. Adamowski, K. Begum, S. Salcedo-Sanz, D.-W. Kim, K. S. Dayal, and H.-R. Byun, "Quantifying flood events in Bangladesh with a daily-step flood monitoring index based on the concept of daily effective precipitation," *Theor. Appl. Climatol.*, vol. 137, nos. 1–2, pp. 1201–1215, Jul. 2019, doi: [10.1007/s00704-018-2657-4](https://doi.org/10.1007/s00704-018-2657-4).
- [7] M. Moishin, R. C. Deo, R. Prasad, N. Raj, and S. Abdulla, "Development of flood monitoring index for daily flood risk evaluation: Case studies in fiji," *Stochastic Environ. Res. Risk Assessment*, pp. 1–16, Oct. 2020, doi: [10.1007/s00477-020-01899-6](https://doi.org/10.1007/s00477-020-01899-6).
- [8] K. Nosrati, M. M. Saravi, and A. Shabazi, "Investigation of flood event possibility over Iran using flood index," in *Survival and Sustainability*. Cham, Switzerland: Springer, 2010, pp. 1355–1361.
- [9] A. Duncan, A. S. Chen, E. Keedwell, S. Djordjevic, and D. Savic, "Urban flood prediction in real-time from weather radar and rainfall data using artificial neural networks," in *Proc. Weather Radar Hydrol. Int. Symp. (WRAH)*. Exeter, U.K.: Univ. Exeter, Apr. 2011.
- [10] Y. LeCun, Y. Bengio, and G. Hinton, "Deep learning," *Nature*, vol. 521, pp. 436–444, May 2015.
- [11] S. Hochreiter and J. Schmidhuber, "Long short-term memory," *Neural Comput.*, vol. 9, no. 8, pp. 1735–1780, 1997.
- [12] A. Graves, "Long short-term memory," in *Supervised Sequence Labelling With Recurrent Neural Networks*. Cham, Switzerland: Springer, 2012, pp. 37–45.
- [13] K.-C. Miao, T.-T. Han, Y.-Q. Yao, H. Lu, P. Chen, B. Wang, and J. Zhang, "Application of LSTM for short term fog forecasting based on meteorological elements," *Neurocomputing*, vol. 408, pp. 285–291, Sep. 2020.
- [14] D. Soutner and L. Müller, "Application of LSTM neural networks in language modelling," in *Proc. Int. Conf. Text, Speech Dialogue*. Cham, Switzerland: Springer, 2013, pp. 105–112.
- [15] C. Hu, Q. Wu, H. Li, S. Jian, N. Li, and Z. Lou, "Deep learning with a long short-term memory networks approach for rainfall-runoff simulation," *Water*, vol. 10, no. 11, p. 1543, Oct. 2018.

- [16] T.-Y. Kim and S.-B. Cho, "Predicting residential energy consumption using CNN-LSTM neural networks," *Energy*, vol. 182, pp. 72–81, Sep. 2019.
- [17] Y. Liu, H. Zheng, X. Feng, and Z. Chen, "Short-term traffic flow prediction with conv-LSTM," in *Proc. 9th Int. Conf. Wireless Commun. Signal Process. (WCSP)*, Oct. 2017, pp. 1–6.
- [18] S. Xingjian, Z. Chen, H. Wang, D.-Y. Yeung, W.-K. Wong, and W.-C. Woo, "Convolutional LSTM network: A machine learning approach for precipitation nowcasting," in *Proc. Adv. Neural Inf. Process. Syst.*, 2015, pp. 802–810.
- [19] B. Faulkner, "Practical applications of the standardised precipitation index (SPI) as a tool for very early warning of droughts and floods in the Balkans region," in *Proc. EGU General Assembly Conf. Abstr.*, vol. 18, 2016, p. 1.
- [20] M. Campolo, P. Andreussi, and A. Soldati, "River flood forecasting with a neural network model," *Water Resour. Res.*, vol. 35, no. 4, pp. 1191–1197, Apr. 1999.
- [21] P. C. Nayak, K. P. Sudheer, D. M. Rangan, and K. S. Ramasastri, "Short-term flood forecasting with a neurofuzzy model," *Water Resour. Res.*, vol. 41, no. 4, pp. 1–16, Apr. 2005.
- [22] D. Han, L. Chan, and N. Zhu, "Flood forecasting using support vector machines," *J. Hydroinformatics*, vol. 9, no. 4, pp. 267–276, Oct. 2007.
- [23] M. Sit and I. Demir, "Decentralized flood forecasting using deep neural networks," 2019, *arXiv:1902.02308*. [Online]. Available: <http://arxiv.org/abs/1902.02308>
- [24] Q.-K. Tran and S.-K. Song, "Water level forecasting based on deep learning : A use case of trinity river-texas-the United States," *J. KIISE*, vol. 44, no. 6, pp. 607–612, Jun. 2017.
- [25] V. V. Krzhizhanovskaya, G. S. Shirshov, N. B. Melnikova, R. G. Belleman, F. I. Rusadi, B. J. Broekhuijsen, B. P. Gouldby, J. Lhomme, B. Balis, M. Bubak, A. L. Pyayt, I. I. Mokhov, A. V. Ozhigin, B. Lang, and R. J. Meijer, "Flood early warning system: Design, implementation and computational modules," *Procedia Comput. Sci.*, vol. 4, pp. 106–115, Jan. 2011.
- [26] E. Lu, "Determining the start, duration, and strength of flood and drought with daily precipitation: Rationale," *Geophys. Res. Lett.*, vol. 36, no. 12, pp. 1–5, 2009, doi: [10.1029/2009gl038817](https://doi.org/10.1029/2009gl038817).
- [27] R. C. Deo, H.-R. Byun, J. F. Adamowski, and D.-W. Kim, "A real-time flood monitoring index based on daily effective precipitation and its application to brisbane and Lockyer valley flood events," *Water. Resour. Manag.*, vol. 29, no. 11, pp. 4075–4093, 2015.
- [28] R. C. Deo, H.-R. Byun, G.-B. Kim, and J. F. Adamowski, "A real-time hourly water index for flood risk monitoring: Pilot studies in Brisbane, Australia, and Dobong Observatory, South Korea," *Environ. Monitor. Assessment*, vol. 190, no. 8, p. 450, Aug. 2018.
- [29] J. R. Medel, "Anomaly detection using predictive convolutional long short term memory units," M.S. thesis, Univ. Rochester Inst. Technol., Tech. Rep., Nov. 2016.
- [30] X. H. Le, H. V. Ho, G. Lee, and S. Jung, "Application of long short-term memory (LSTM) neural network for flood forecasting," *Water*, vol. 11, no. 7, 2019.
- [31] I. E. Livieris, E. Pintelas, and P. Pintelas, "A CNN-LSTM model for gold price time-series forecasting," *Neural Comput. Appl.*, vol. 32, no. 23, pp. 17351–17360, 2020.
- [32] H. Drucker, C. J. Burges, L. Kaufman, A. J. Smola, and V. Vapnik, "Support vector regression machines," in *Proc. Adv. Neural Inf. Process. Syst.*, 1997, pp. 155–161.
- [33] V. Sutton, "Fiji: Climate change, tradition and Vanua," in *Climate Change and Indigenous Peoples*. Cheltenham, U.K.: Edward Elgar Publishing, 2013.
- [34] J. Feresi, G. J. Kenny, N. de Wet, L. Limalevu, J. Bhusan, and I. Ratukalou, "Climate change vulnerability and adaptation assessment for Fiji," Int. Global Change Inst., Univ. Waikato., Hamilton, New Zealand, Tech. Rep., 2000.
- [35] S. McGree, S. W. Yeo, and S. Devi, "Flooding in the Fiji Islands between 1840 and 2009," *Risk Frontiers*, pp. 1–69, Oct. 2010, doi: [10.13140/RG.2.2.24364.67202](https://doi.org/10.13140/RG.2.2.24364.67202).
- [36] (2019). *MATLAB*. [Online]. Available: <https://au.mathworks.com/products/matlab.html>
- [37] H.-R. Byun and D.-K. Lee, "Defining three rainy seasons and the hydrological summer monsoon in Korea using available water resources index," *J. Meteorological Soc. Jpn.*, vol. 80, no. 1, pp. 33–44, 2002.
- [38] M. F. Sanner, "Python: A programming language for software integration and development," *J. Mol. Graph Model.*, vol. 17, no. 1, pp. 57–61, 1999.
- [39] A. Boschetti and L. Massaron, *Python Data Science Essentials*. Birmingham, U.K.: Packt, 2015.
- [40] F. Pedregosa, G. Varoquaux, A. Gramfort, V. Michel, B. Thirion, O. Grisel, M. Blondel, P. Prettenhofer, R. Weiss, V. Dubourg, J. Vanderplas, A. Passos, D. Cournapeau, M. Brucher, M. Perrot, and E. Duchesnay, "Scikit-learn: Machine learning in Python," *J. Mach. Learn. Res.*, vol. 12, pp. 2825–2830, Oct. 2011.
- [41] M. Abadi et al., "Tensorflow: A system for large-scale machine learning," in *Proc. 12th USENIX Symp. Oper. Syst. Design Implement. (OSDI)*, 2016, pp. 265–283.
- [42] N. Ketkar, "Introduction to Keras," in *Deep Learning With Python*. Cham, Switzerland: Springer, 2017, pp. 97–111.
- [43] S. Ghimire, R. C. Deo, N. Raj, and J. Mi, "Deep solar radiation forecasting with convolutional neural network and long short-term memory network algorithms," *Appl. Energy*, vol. 253, Nov. 2019, Art. no. 113541.
- [44] R. D'Agostino and E. S. Pearson, "Tests for departure from normality. Empirical results for the distributions of b^2 and $\sqrt{b_1}$," *Biometrika*, vol. 60, no. 3, pp. 613–622, 1973.
- [45] Y.-W. Cheung and K. S. Lai, "Lag order and critical values of the augmented dickey-fuller test," *J. Bus. Econ. Statist.*, vol. 13, no. 3, pp. 277–280, 1995.
- [46] R. Prasad, L. Joseph, and R. C. Deo, "Modeling and forecasting renewable energy resources for sustainable power generation: Basic concepts and predictive model results," in *Translating the Paris Agreement Into Action in the Pacific*. Cham, Switzerland: Springer, 2020, pp. 59–79.
- [47] F. K. Boadu, "Rock properties and seismic attenuation: Neural network analysis," *Pure Appl. Geophysics*, vol. 149, no. 3, pp. 507–524, Jun. 1997.
- [48] J. Brownlee, *How to Develop LSTM Models for Time Series Forecasting*. Accessed: Feb. 17, 2021. [Online]. Available: <https://machinelearningmastery.com/how-to-develop-lstm-models-for-time-series-forecasting/>
- [49] T. Hallouin, "ThibHlln/hydroeval: General enhancements," Hydroeval, Zenodo, Tech. Rep., 2019, doi: [10.5281/zenodo.2591217](https://doi.org/10.5281/zenodo.2591217).
- [50] W. Roberts, G. P. Williams, E. Jackson, E. J. Nelson, and D. P. Ames, "Hydrostats: A Python package for characterizing errors between observed and predicted time series," *Hydrology*, vol. 5, no. 4, p. 66, Dec. 2018.



MOHAMMED MOISHIN received the bachelor's degree in software engineering from The University of the South Pacific, Fiji, in 2019. He is currently pursuing the Master of Science Research degree with the Advanced Data Analytics Group, School of Sciences, University of Southern Queensland–Springfield, Australia. His research interests include flood risk mitigation, artificial intelligence and machine learning, and software development.



RAVINESH C. DEO (Senior Member, IEEE) is currently a Professor with research interests in artificial intelligence and deep learning. He was awarded internationally competitive Queensland Smithsonian, JSPS, Chinese Academy, Australia-India Strategic Fellowship, and Endeavour Fellowships and supervised 20 Ph.D./M.Sc. degrees, received employee excellence awards, Faculty Research Excellence, Elsevier Highly Cited Paper, Publication Excellence, and Teaching Commendation. He is also an academic and industry mentor through grants worth \$2.6M and services editorial boards of *Stochastic Environmental Research and Risk Assessment*, *IEEE Access*, *Remote Sensing*, *Energies*, and *Journal of Hydrologic Engineering*. He has published 220 articles, including 150 journals (85% Quartile 1), and six books in Elsevier, Springer, IGI, with 23 Book Chapters. His work has cumulative citations exceeding 6200 with an H-index 43.



RAMENDRA PRASAD received the B.Sc. degree in mathematics and physics and the M.Sc. degree in physics from The University of the South Pacific, Fiji, and the Ph.D. degree in modeling and simulations from the University of Southern Queensland, Australia, in 2019. Since 2018, he has been a Lecturer with The University of Fiji. He has authored 15 articles in peer-reviewed journals and reputed conferences. His research interests include advanced machine learning approaches, data analytics, hydrological modeling, energy modeling, energy management, environmental, atmospheric modeling, and ocean wave modeling.



NAWIN RAJ received the B.Sc., B.Ed., PGDMA, and M.Sc. degrees in computational fluid dynamics from The University of the South Pacific, and the Ph.D. degree from the University of Southern Queensland, Australia, in 2015. From 2007 to 2010, he was a Lecturer with Fiji National University. He is currently a Lecturer with USQ. His research interests include artificial intelligence, deep learning, non-linear oscillation, computational fluid dynamics, and oceanography. He is also a member of the Australian Mathematical Society and the Queensland College of Teachers.



SHAHAB ABDULLA is currently a Senior Lecturer of (Mathematics/Communication). His interdisciplinary interests include artificial intelligence models and bioinformatics (health, energy, biomedical, control systems, control science, and sustainable agriculture) under these Codes (0103) Numerical and Computational Mathematics, (0502) Environmental Science and Management, (0701) Agriculture, (01) Mathematical Sciences, and (08) Information and Computing Sciences. Designing expert systems to his research interests, including deep learning, convolutional neural, and long- short-term memory networks. His leadership was recognized by many awards. He has served on several committees. He was the Chair of IEEE conference. He collaborates with researchers in Middle East, USA, Japan, Europe, China, and Canada, delivered over 30 seminars. In last three years, his articles were cited more than 200 times. With more than 25 publications (largely in Q1 journals), he leads the Advanced Data Analytics Modeling Research Simulation Group, as a Principal Supervisor and an Associate Supervisor of more than ten Ph.D./master’s/HDR students. He has supervised more than five Ph.D./master’s thesis/dissertations and examined a number of these locally and overseas.

...