



University of Pennsylvania  
**ScholarlyCommons**

---

Theses (Historic Preservation)

Graduate Program in Historic Preservation

---

1-2021

## **Belleza Desnuda: A Conservation Assessment of the Exterior Concrete Surfaces of Henry Klumb's Parroquia Nuestra Señora del Carmen in Cataño, Puerto Rico**

Hector Berdecia-Hernandez

Follow this and additional works at: [https://repository.upenn.edu/hp\\_theses](https://repository.upenn.edu/hp_theses)

 Part of the [Historic Preservation and Conservation Commons](#)

---

Berdecia-Hernandez, Hector, "Belleza Desnuda: A Conservation Assessment of the Exterior Concrete Surfaces of Henry Klumb's Parroquia Nuestra Señora del Carmen in Cataño, Puerto Rico" (2021). *Theses (Historic Preservation)*. 706.

[https://repository.upenn.edu/hp\\_theses/706](https://repository.upenn.edu/hp_theses/706)

This paper is posted at ScholarlyCommons. [https://repository.upenn.edu/hp\\_theses/706](https://repository.upenn.edu/hp_theses/706)  
For more information, please contact [repository@pobox.upenn.edu](mailto:repository@pobox.upenn.edu).

---

# Belleza Desnuda: A Conservation Assessment of the Exterior Concrete Surfaces of Henry Klumb's Parroquia Nuestra Señora del Carmen in Cataño, Puerto Rico

## Abstract

The Parroquia Nuestra Señora del Carmen was founded in 1893 in the coastal town of Cataño, Puerto Rico. In 1957, the Dominican Catholic Order commissioned architect Henry Klumb to design a modern church, which was inaugurated in June 1962. Since its opening, the Del Carmen Church has remained relatively unchanged, yet efforts to maintain and 'improve' the building over the years, including painting the original exposed cement stucco exteriors, an important character-defining feature of its design; has contributed toward a misunderstanding and underappreciation of one of Klumb's most significant works on the island. This case study examines Henry Klumb's original design intent for the Del Carmen Church and its subsequent alterations over time, including the current conditions of the concrete and exterior cement stucco in the tropical coastal environment of Puerto Rico. The study was comprised of four phases: Firstly, an in-depth analysis of archival research of the building, its design, the historical context, and its construction and maintenance. The second phases include a conditions survey and assessment with a detailed focus and evaluation of the exterior Portland cement stucco. The third phase focused on physico-chemical analysis of selected samples from the cement stucco and the concrete substrates that included: petrography, micro-drop water absorption testing, microchemical spot test, salt content, carbonation testing, x-ray diffraction (XRD), and scanning electron microscopy with energy dispersive x-ray spectroscopy (SEM-EDS). The last phase recommends a cleaning program to determine the best treatment options for removing the current painted coatings without affecting the cement stucco and aiding the building's restoration to its original appearance. Henry Klumb's Del Carmen Church in Cataño, Puerto Rico, exemplifies how common conservation issues for modern heritage, such as design intent, weathering, authenticity, and material realities, are global concerns and how informed scientific investigations can aid in better interpretation and conservation.

## Keywords

Portland cement stucco, modern church architecture, concrete conservation, Puerto Rico, Caribbean

## Disciplines

Historic Preservation and Conservation

BELLEZA DESNUDA: A CONSERVATION ASSESSMENT OF THE EXTERIOR  
CONCRETE SURFACES OF HENRY KLUMB'S PARROQUIA NUESTRA  
SEÑORA DEL CARMEN IN CATAÑO, PUERTO RICO

Héctor Jabneel Berdecía-Hernández

A THESIS

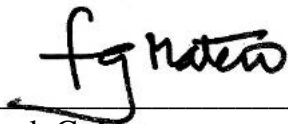
in

Historic Preservation

Presented to the Faculties of the University of Pennsylvania in  
Partial Fulfillment of the Requirements of the Degree of

MASTER OF SCIENCE IN HISTORIC PRESERVATION

2020



---

Frank G. Matero  
Advisor & Chair  
Graduate Program in Historic Preservation  
Professor of Architecture

## DEDICATION

To the Islands

A la(s) Isla(s)

“Puerto Rico creció en el Siglo XX con hormonas, por ello no espere que aguante crisis, y que su infraestructura culo-de-res resista azote o el deterioro de los años.

No somos el arbolito que creció a su ritmo; nos forzaron a dar un ‘milagroso’ estirón gestionado para el espectáculo político, no para la longevidad de un país.

Somos un lugar permanentemente provisional. No salimos de ello.

Cuando se crece con prisa, y de manera desigual, pues no todos pudieron crecer a la velocidad que le impusieron, proliferan los puntos y áreas de vulnerabilidad.

Somos un lugar hipertrófico e inmaduro. Nos hemos dejado diseñar así. Muchos ni siquiera cuentan con las herramientas para resistirlo o imaginarse de otra manera...”

-M. Rodríguez Casellas, January 2020

## ACKNOWLEDGEMENTS

This thesis is the product of an almost two-year research journey in which I had the opportunity to meet extraordinary heritage conservation professionals. First, I would like to thank my advisor and mentor, Frank G. Matero, for his dedication, patience, and support these past two and a half years. It has been a privilege and an honor to attend Penn, and I am genuinely grateful for the opportunity. I would like to recognize and thank conservation architect Beatriz del Cueto, FAIA, and Dr. Enrique Vivoni Farage for their support and dedication through this journey. It has also been a privilege to work alongside them in the development of this research. I am also grateful for the support and assistance of Courtney Magill, especially during the instrumental analyses for my thesis, and Micah Dornfield. I want to thank Dr. Marie-Claude Boileau, Director for the Center of Archaeological Materials (CAAM) at the Penn Museum, for her patience and support while developing the petrographic analysis for this research. I would also like to thank Jamie Ford from the Laboratory for Research on Structure of Matter (LRSM) for his assistance with the SEM-EDS analysis. My very special thanks to Kecia Fong for her support during my time at Penn.

My deepest gratitude to Friar Emmanuelle Toledo, O.P., and the Church's staff for their unconditional support on this project and providing unlimited access to the Church. I would also like to recognize and thank Elena García and Nydia Vigil for their support during this research and assistance in accessing all archival documents and drawings from the Del Carmen Church at the UPR Architecture and Construction Archives' (AACUPR) Klumb Collection. My special thanks to Dr. Luz Marie Rodríguez for her support, advice, and long conversations related to my research, which helped me refine this project. I would also like to recognize and thank Dr. George Wheeler for his assistance while I was developing the testing schedule and for providing valuable resources for my project. My gratitude to Amy Woods from the International Masonry Institute for her advice and for sharing technical resources that helped my research. I want to thank Prof. Michael Henry for his advice on the initial phases of this thesis.

I am also thankful for the assistance of Gamaliel Pérez, which provided the ladders that allowed me to access the upper parts of the Church. My gratitude to Roy Ingraffia, architect Héctor Balvanera, Dr. Rosa Otero, concrete petrographer Karla Salahshour, Dr. Mayra Rosario Urrutia, Dr. Guillermo A. Baralt, and architects Rafael Marrero & Andrés

Rivera for their assistance in providing valuable information and resources which complemented by research. My special thanks to my mentor conservation architect Carlos A. Rubio Cancela, the Puerto Rico State Historic Preservation Officer, for his encouragement and ideas since the initial phases of this research. My acknowledgment and gratitude to my friends Nelmaris Camacho García, María del Mar Pérez, and Minette Bonilla Ramos for their archival research assistance. I also want to thank my mentor and friend, conservation architect Pablo Ojeda O'Neill, director of the Built Heritage Program at the Institute of Puerto Rican Culture, for his advice and support through this journey and the long helpful discussions.

I am thankful to the Association for Preservation Technology International-Delaware Valley Chapter (APT-DVC) for the financial support to attend the *Conservation of Modern Concrete and Terrazzo Flooring Workshop* at the 2019 APT Annual Conference in Miami, FL in November 2019. That experience shaped the development of this thesis.

This research was presented in the Association for Preservation Technology International (APT) and the National Trust for Canada Joint Annual Meeting on October 5th, 2020. I am thankful to my APT Mentor, Susan Macdonald, Head of Buildings and Sites at the Getty Conservation Institute, for her advice and feedback on my research and presentation as a Student Scholar. This research was also presented as part of the Student Poster Session at the International Institute for Conservation of Historic and Artistic Works (IIC) 28<sup>th</sup> Biennial Congress held on November 2-6, 2020.

Last but not least, my deepest gratitude to my parents Keila and Carlos, my Family for their unconditional support through this research and my journey at Penn.

Thank you, Lord almighty.

# CONTENTS

LIST OF FIGURES	viii
LIST OF TABLES	xix
INTRODUCTION	1
CHAPTER 1	8
1.1 Concrete and ‘Modernity’ in Puerto Rico	8
1.1.1 Early introduction of Cement in Puerto Rico	11
1.1.2 Twentieth-Century Development of Reinforced Concrete in PR	12
1.1.3 The In-between period	17
1.1.4 Concrete and ‘Modernity’	19
1.1.5 World War II and the U.S. Military Infrastructure projects	24
1.1.6 After the War	27
1.1.7 Conclusions	32
1.2 The rise of the Concrete modern church	33
1.3 Portland Cement and Concrete in Puerto Rican Church Architecture	37
CHAPTER 2	54
2.1 Henry Klumb, the architect and his churches	54
2.2 Del Carmen Church: its history, design, and construction	61
2.3 Klumb’s design approach	83
CHAPTER 3	100
3.0.1 Portland cement stucco	102
3.0.2 “Sprayed” Stucco or Pneumatically applied mortar	103
3.1 Cement finishes in Klumb’s designs	104
3.2 Stucco finishes at the Del Carmen Church	114
3.2.1 Materials Characterization	116
3.2.2 Stucco application processes	124
3.3 Historical evolution of Portland cement stucco	132
3.4 Historical evolution of Shotcrete 1907 – 1960s	149
CHAPTER 4	171
4.1 Purpose and scope	171
4.2 Methodology	173
4.3 Limitations	181

4.4 Description of the concrete in the Del Carmen Church	181
4.5 Discussion of the exterior stuccoed finishes	184
4.6 Climate in Cataño, Puerto Rico	187
4.7 Deterioration of Concrete and Cement stucco	189
4.8 Current conditions of the exterior surfaces of the Del Carmen Church	196
4.9 Findings – Specific conditions	205
4.10 Potential risks exacerbated by climate change	209
4.11 Recommendations for future assessments, further testing, and monitoring	211
CHAPTER 5	216
5.1 Sampling Methodology	219
5.2 Instrumental Analyses	220
5.2.1 Stereomicroscopy of Bulk Samples	220
5.2.2 Carbonation	222
5.2.3 Semi-Quantitative Salt Analysis	223
5.2.4 Microdrop water absorption test	225
5.2.5 Micro-chemical spot test	227
5.2.6 Polarized Light Microscopy (PLM) / Concrete Petrography	229
5.2.7 X-Ray Powder Diffraction Spectrometry (XRD)	240
5.2.8 Scanning Electron Microscopy (SEM-EDS)	244
5.3 General Conclusions	249
CHAPTER 6	253
6.1 Considerations before choosing Conservation Treatments	254
6.2 Cleaning	257
6.3 Coating Protection Systems - Penetrants	259
6.4 Corrosion Inhibitors/Cathodic Protection Systems	262
6.5 Further Testing	264
6.6 Mechanical Repairs	264
6.7 Conclusions	265
BIBLIOGRAPHY	268
APPENDIXES	284
Appendix 1 – Conditions Glossary	284
Appendix 2 – Conditions Assessment	290
Appendix 3 – Climate Data	361
Appendix 4 – Grille Climatique – Climate Data Analysis	367



Appendix 5 – Sample Matrix & Locations	369
Appendix 6 – Samples	377
Appendix 7 – Testing Matrix	385
Appendix 8 – Stereomicroscope Photos	390
Appendix 9 – Carbonation Test Data	403
Appendix 10 – Microdrop Water Absorption Testing Data	410
Appendix 11 – Microchemical Spot Test	414
Appendix 12 – Semi-Quantitative Salt Analysis Results	416
Appendix 13 – Petrographic Report	428
Appendix 14 – X-Ray Powder Diffraction Spectrometry (XRD) Data	487
Appendix 15 – Scanning Electron Microscopy (SEM-EDS) Data	503
Appendix 16 – Journals and Magazines	516
Appendix 17 – Letter from ICP	532
Appendix 18 – Construction Chronology of the Del Carmen Church	533
INDEX	541

## LIST OF FIGURES

Figure 1.1	Acueducto de Río Piedras/Río Piedras Aqueduct. Source: <i>Puerto Rico Ilustrado, 1919.</i>	12
Figure 1.2	The Federal Building and U.S. Courthouse in Old San Juan, built-in 1914. Source: "US Post Office and Courthouse/Old San Juan Federal Building" <i>National Register of Historic Places Inventory/Nomination Form.</i>	14
Figure 1.3	Atlas Cement advertisement featuring the Roman Baldority De Castro School in Old San Juan on the local <i>Revista de Obras Públicas</i> in 1925.	15
Figure 1.4	Century Cement Machine Co. promoting the Hercules Concrete Block Machine as the selected technology for School construction by the 'Porto Rico' Board of Education in 1907. Source: <i>The National Builder</i> , Jun 1 <sup>st</sup> , 1907, Vol. 44, No. 6, p. 59.	15
Figure 1.5	The house of prominent Architect Antonin Nechodoma. Source: <i>Building Age</i> , August 1918, Vol. 40, No. 8, p. 396.	16
Figure 1.6	House of Mr. J.B. Diaz, today known as Casa Benítez in Miramar. Source: <i>Building Age</i> , August 1918, Vol. 40, No. 8, p. 396.	16
Figure 1.7	Original Punta Higüera/Point Jiquero Lighthouse in Rincón (West coast side of Puerto Rico) which suffered structural damages after the San Fermín Earthquake. Source: <i>U.S. National Archives</i> . Department of Commerce, Bureau of Lighthouses Photographic Collection.	18
Figure 1.8	Photo of the Urbanización Morell Campos in Ponce under construction. Source: Biblioteca Digital Puertorriqueña, University of Puerto Rico-PRRA Collection.	20
Figure 1.9	The Cataño Cement Plant completed in 1938 and renamed the Puerto Rico Cement Corporation (PRCC) in 1940. Source: National Archives Record Group 135-SAR: Scanned and processed by Evan Kalish. <a href="https://livingnewdeal.org/projects/catano-cement-plant-guaynabo-pr/">https://livingnewdeal.org/projects/catano-cement-plant-guaynabo-pr/</a>	22
Figure 1.10		
Figure 1.11	The Ponce Cement Corporation Plant in 1949. Source: Archivo General de Puerto Rico (AGPR)/Puerto Rico General Archives, Mirabal Collection – Ponce.	25
Figure 1.12	Governor Luis Muñoz Marín visiting a Slum (c.1951) at the Condado Lagoon which was to be eliminated after his official visit. Source: Rafael Picó, <i>Diez Años de Planificación en Puerto Rico</i> . Junta de Planificación de Puerto Rico, 1952, 43. Colección Puertorriqueña, UPR.	26
Figure 1.13	Photo of the Urbanización Puerto Nuevo seen from the San Patricio area c.1949. Source: Héctor Ruiz, "Urbanización Puerto Nuevo-1949", <i>Redescubriendo a Puerto Rico</i> Blog, March 13th, 2013, <a href="https://redescubriendoapuertorico.blogspot.com/2013/03/urbanizacion-puerto-nuevo-1949.html">https://redescubriendoapuertorico.blogspot.com/2013/03/urbanizacion-puerto-nuevo-1949.html</a>	28
Figure 1.14	Photo of the Inaguguration of the housing complex in 1953. Source: Biblioteca Digital Puertorriqueña, University of Puerto Rico – El Mundo.	29
Figure 1.15	The ideas of 'progress' behind the use of Portland Cement in Puerto Rico. Souce: <i>Revista Urbe</i> , Dec 1964-Jan-Feb 1965, p. 58.	31
Figure 1.16	The ideas of 'progress' behind the use of Portland Cement in Puerto Rico. Source: <i>Revista Urbe</i> , Apr-May 1968, p. 18.	31
Figure 1.17	The ideas of 'progress' behind the use of Portland Cement in Puerto Rico. Source: <i>Revista Urbe</i> , Oct-Nov 1967, p. 14.	31
Figure 1.18	Church of Notre Dame du Raincy in Le Raincy built between 1922 and 1923 by French Architect Auguste Perret. Source: T.P. Bennett, <i>Architectural design in concrete</i> , Ernest Benn Ltd., 1927, <a href="http://collectionsblog.aaschool.ac.uk/notre-dame-du-raincy-architectural-design-in-concrete/">http://collectionsblog.aaschool.ac.uk/notre-dame-du-raincy-architectural-design-in-concrete/</a>	35
Figure 1.19	Frank Lloyd Wright's Unity Temple built in 1904, photo by Henry Fuermann and Sons Photography Company, c. 1910. Source: Frank Lloyd Wright Preservation Trust – Digital Image Collection <a href="http://cdm15014.contentdm.oclc.org/cdm/singleitem/collection/p15014coll3/id/36/rec/3">http://cdm15014.contentdm.oclc.org/cdm/singleitem/collection/p15014coll3/id/36/rec/3</a>	36

Figure 1.20	The Abbey of St. John the Baptist in Collegeville, Minnesota, by Marcel Breuer in 2019. Source: Minnevangelist, <a href="https://minnevangelist.com/saint-johns-abbey-collegeville/">https://minnevangelist.com/saint-johns-abbey-collegeville/</a>	36
Figure 1.21	In 1899, the Protestant Missionaries divided the main island of Puerto Rico into 8 to 9 districts. Source: Samuel Silva Gotay, <i>Protestantismo y Política En Puerto Rico- 1898-1930</i> , p. 113.	38
Figure 1.22	The Methodist Church in Miramar, San Juan built in 1908 & the First United Methodist Church in Ponce built in 1907. Source: <i>Concrete</i> , Vol. 9, No. 7, Jul 1st 1909, p. 35.	39
Figure 1.23	Protestant churches built around the Islands up to 1921. Source: E. Fernandez García, Ed., <i>El Libro de Puerto Rico/The Book of Porto Rico</i> , San Juan, PR: El Libro azul publishing Co., 1923, p. 134.	39
Figure 1.24	Iglesia de San Agustin / St. Augustine Parochial Church in Puerta de Tierra, San Juan c.1930s. Source: Rodríguez Archives – Archivo Fotográfico Digital de Puerto Rico.	40
Figure 1.25	The Santa Rosa de Lima Church in Bayamón (1946-1947). Source: AACUPR – Klumb Collection	42
Figure 1.26	Sanctuary of the Blessed Martín de Porres (1946-1952) in Cataño. Source: AACUPR – Klumb Collection.	43
Figure 1.27	The San Judas Tadeo Sanctuary in Cataño (1953-1961). Photo by Héctor Balvanera, 2018.	43
Figure 1.28	The Dominican Seminary in Bayamón (1963). Source: AACUPR – Klumb Collection.	43
Figure 1.29	The Del Carmen Church in Cataño (1962). Source: AACUPR – Klumb Collection.	44
Figure 1.30	The San Ignacio Church for the Franciscan Order in Río Piedras (1963-1967). Photo by Héctor Balvanera, 2018.	44
Figure 1.31	The Santa Catalina de Siena Church (1962-1963) in Bayamón by architect Efraín Pérez Chanis. Source: José Fernández, <i>Architecture in Puerto Rico</i> , 1965, p. 166.	45
Figure 1.32	The Santos Ángeles Custodios Church (1964-1968) in Yabucoa by Amaral y Morales architects. Source: Marvel & Moreno, <i>Architecture of Parish Churches in Puerto Rico</i> , 2 <sup>nd</sup> Ed., 1994, p. 188.	45
Figure 1.33	The Santa María Reina Church (1955-1957) in Ponce by Méndez, Brunner, Badillo & Asociados. Source: Colourpicture Publishers Inc.	45
Figure 2.1	Architect Frank Lloyd Wright and young Henry Klumb at Talesin West in the 1920s. Source: AACUPR – Henry Klumb Collection.	55
Figure 2.2	Henry and his wife, Elsie Klumb standing outside of their famous House- <i>Casa Klumb</i> . House Source: AACUPR – Henry Klumb Collection.	56
Figure 2.3	Social Science Faculty Building, UPR Río Piedras, San Juan, PR (1964). Source: AACUPR – Henry Klumb Collection.	57
Figure 2.4	Hotel La Rada in San Juan, PR (1950). Source: AACUPR – Henry Klumb Collection.	58
Figure 2.5	Park Davis & Company Building in Carolina, PR (1959). Source: AACUPR – Henry Klumb Collection.	58
Figure 2.6	The Sanctuary of Blessed San Martín de Porres in Cataño. Source: AACUPR – Henry Klumb Collection.	59
Figure 2.7	Nave at the Sanctuary of Blessed San Martín de Porres in Cataño. Source: AACUPR – Henry Klumb Collection.	59
Figure 2.8	Henry Klumb in 1963. Source: <i>Caribbean Traveler: The Antillean Magazine</i> , January 1967, AACUPR – Henry Klumb Collection.	61
Figure 2.9	The islands of Puerto Rico. Cataño, founded officially in 1927, is the smallest Municipality in Puerto Rico and is located on the northern part of the main island.	62
Figure 2.10	The San Juan bay. Both Cataño and the historic city of Old San Juan share the bay. The municipality is located on the southern side of the bay. Source: Google Maps.	62
Figure 2.11	Aerial photo of Cataño and its plaza facing the bay. Source: Google Maps.	63
Figure 2.12	The city block in which Del Carmen Church stands. Photo by Diana Serrano, December 2019.	63
Figure 2.13	Del Carmen Church within its urban context. Photo by Diana Serrano, 2019.	65
Figure 2.14	Del Carmen Church within its urban context. Photo by Author, 2019.	65

Figure 2.15	The old Del Carmen Church building from 1904-1905, c.1950s. Source: AACUPR – Henry Klumb Collection.	67
Figure 2.16	Del Carmen Church site plan from 1958 before the construction of the new church. Source: AACUPR – Henry Klumb Collection.	68
Figure 2.17	The Nuestra Señora del Carmen Plaza in Cataño, c.1957-1958. The old church can be seen standing to the south side of the Plaza. Source: AACUPR – Henry Klumb Collection.	68
Figure 2.18	The Del Carmen Church originally occupied half of the present-day lot. Photos c.1957-1958. Source: AACUPR – Henry Klumb Collection.	69
Figure 2.19	One of the original wooden houses in the Town was demolished to make space for the new church. Source: AACUPR – Henry Klumb Collection.	69
Figure 2.20	An early concept sketch found among the archival records of the Church. Source: AACUPR – Henry Klumb Collection.	70
Figure 2.21	Section - Early design concept for the Del Carmen Church in 1960. Source: AACUPR – Henry Klumb Collection.	72
Figure 2.22	Floor Plan - Early design concept for the Del Carmen Church in 1960. Source: AACUPR – Henry Klumb Collection.	72
Figure 2.23	Structural drawings and calculations of the original design. Source: A. Komendant, <i>Contemporary Concrete Structures</i> (McGraw-Hill) 1972, p. 501-504.	73
Figure 2.24	Bermudez, Hernández & Muratti Engineers announcement featured in the <i>Proyectos y Materiales</i> journal. Source: Revista Proyectos y Materiales, Jul-Aug 1949 – Henry Klumb Collection, AACUPR.	74
Figure 2.25	Elevations - The final design for the Del Carmen Church. Source: AACUPR – Henry Klumb Collection.	75
Figure 2.26	Section - The final design for the Del Carmen Church. Source: AACUPR – Henry Klumb Collection.	75
Figure 2.27	Axo - The final design for the Del Carmen Church. Source: AACUPR – Henry Klumb Collection.	75
Figure 2.28	The small porch space and the continuous curvilinear north elevation. Photo by Javier Freytes, December 2019.	77
Figure 2.29	The small porch space and the continuous curvilinear north elevation. Photo by Javier Freytes, December 2019.	77
Figure 2.30	The simple linear concrete block belfry/bell tower. Photo by Javier Freytes, December 2019.	78
Figure 2.31	The nave with the altar in the back. Photo by Javier Freytes, December 2019.	78
Figure 2.32	A view of the Nave from the south to the north. Photo by Javier Freytes, December 2019.	79
Figure 2.33	The small daily chapel. Photo by Javier Freytes, December 2019.	79
Figure 2.34	Looking from the Chapel to the narthex and baptistry (northeast side of the church). Photo by Javier Freytes, December 2019.	81
Figure 2.35	The sculptural exterior of the church as seen from the southwest side and the back patio. Photo by Diana Serrano, December 2019.	82
Figure 2.36	Details of the original exterior stuccoed surfaces on the northeast side of the church, c.1963. Source: AACUPR – Henry Klumb Collection.	83
Figure 2.37	The original spatial arrangement of the nave with a central altar c.1963. Source: AACUPR – Henry Klumb Collection.	87
Figure 2.38	Terra cotta hollow block wall on the southeast side of the church, which allows a passive ventilation system and an interior-exterior connection. Photo by Javier Freytes, December 2019.	89
Figure 2.39	The entrance planter on the northwest side of the church. Photo by Javier Freytes, December 2019.	89
Figure 2.40	The original mahogany pews in the Del Carmen Church. Photo by Javier Freytes, December 2019.	90

Figure 2.41	Photo of the Notre Dame-du-haut Church at Ronchamp built in 1954 by Le Corbusier, found in Klumb’s records. Source: AACUPR – Henry Klumb Collection.	93
Figure 2.42	Del Carmen Church in 1965, photo by Conrad Elger & Alexander Georges. Source: AACUPR – Henry Klumb Collection.	93
Figure 2.43	Photo of a Stuccoed Wall at the Notre Dame-du-haut Church at Ronchamp. Photo by Lucien Herve. Source: <i>Manual of Lathing and Plastering</i> by John R. Diehl, 1960.	94
Figure 3.1	Drawings of The Cerezal Homes in Río Piedras (1949). Klumb used both smooth and rough variations of stucco, or smooth stuccoes on the exteriors. Source: Henry Klumb Collection – AACUPR.	106
Figure 3.2	Elevation of the IBM Office Building for the San Juan Real Estate Corp., in Santurce (1958). Source: Henry Klumb Collection – AACUPR.	108
Figure 3.3	Photo of the IBM Office Building for the San Juan Real Estate Corp., in Santurce (1958). Source: Henry Klumb Collection – AACUPR.	108
Figure 3.4	Elevation of the Bueno House Addition in Punta Las Marías, Santurce (1967). Source: Henry Klumb Collection – AACUPR.	109
Figure 3.5	The San Martín Office Building & Condominium, Santurce (1957) featured the use of the “Rough Cement Plaster Finish” on the building’s exteriors. Source: Henry Klumb Collection – AACUPR.	109
Figure 3.6	Photo of the original “Stippled Cement Plaster Finish” at the entrance of the UPR Museum of History, Anthropology and Art designed by Klumb in 1948. Photo by Author, 2018.	110
Figure 3.7	The Colegio San Ignacio de Loyola (1952). Source: Henry Klumb Collection, AACUPR.	111
Figure 3.8	Centro de Estudiantes/Student Hall at the University of Puerto Rico, Río Piedras Campus (1958). Source: Henry Klumb Collection, AACUPR.	111
Figure 3.9	The Ciba-Geigy Pharmaceutical Plant in collaboration with engineer A. Komendant, built in 1984. Source: Komendant Collection, University of Pennsylvania Architectural Archives.	113
Figure 3.10	Wall - The Ciba-Geigy Pharmaceutical Plant in collaboration with engineer A. Komendant, built in 1984. Source: Komendant Collection, University of Pennsylvania Architectural Archives.	113
Figure 3.11	Photo of the dome at the southeast side of the Church. Photo by Conrad Elger & Alexander Georges c. 1964-1966. Source: Henry Klumb Collection – AACUPR.	121
Figure 3.12	A cross section of the dome stucco with the visible ferrous particulate fillings after sampling on the northwest elevation. Photo by Author, February 2020.	123
Figure 3.13	Common plastering tools in the mid-twentieth century. Source: <i>Manual of Lathing and Plastering</i> by John R. Diehl (1960), p. 84-88.	126
Figure 3.14	Comparison of dry-mix and wet-mix processes. Source: ACI 506R-16 – Guide to Shotcrete, p. 3.	128
Figure 3.15	Dry-mix application of Shotcrete in the 1960s. Source: <i>Manual of Lathing and Plastering</i> by John R. Diehl (1960), p. 176.	129
Figure 3.16	Dry-mix application of Shotcrete in the 1960s with the use of a hand hopper machines was also common in the era, suitable for sprayed finish coats. Source: <i>Manual of Lathing and Plastering</i> by John R. Diehl (1960), p. 91.	129
Figure 3.17	Standard Stucco Finishes marketed between the 1910s and 1920s. Source: <i>The Stucco House</i> (1921), p. 64.	135
Figure 3.18	Standard Stucco Finishes marketed since the mid-20 <sup>th</sup> century. Source: <i>Modern Modes in Better Plastering</i> (1926), p. 20.	137
Figure 3.19	Hotel Americana in the Central Aguirre in Salinas, Puerto Rico, built-in 1926. Source: Yanitza Montero Rivera (2019).	138
Figure 3.20	Hotel Americana in the Central Aguirre in Salinas, Puerto Rico, built-in 1926. Source: AACUPR.	138
Figure 3.21	Hotel Americana in the Central Aguirre in Salinas, Puerto Rico, built-in 1926. Source: AACUPR.	138

Figure 3.22	University of Puerto Rico Buildings designed by architect Rafael Carmoega in the 1930s. Photo by the Author, 2018.	139
Figure 3.23	University of Puerto Rico Buildings designed by architect Rafael Carmoega in the 1930s. Photo by the Author, 2018.	139
Figure 3.24	In Puerto Rico, Czech architect Antonin Nechodoma incorporated the use of mosaics and flat Portland cement stucco. Source: Earl K. Burton, "Concrete Bungalows in Porto Rico" <i>Keith's Magazine on Home Building</i> , Vol. XXXV, No. 4, April 1916, p. 246.	140
Figure 3.25	In Puerto Rico, Czech architect Antonin Nechodoma incorporated the use of mosaics and flat Portland cement stucco. Source: "Spanish Style Bungalow of the Tropics: Details of a Dwelling to Meet Warm Climate" <i>Buiding Age</i> , April 1914, p. 19.	140
Figure 3.26	Suburban houses developed by the Puerto Rico Reconstruction Administration (PRRA) at the Urb. Eleanor Roosevelt in Hato Rey, San Juan (1937).	143
Figure 3.27	Suburban houses developed by the Puerto Rico Reconstruction Administration (PRRA) at the Urb. Eleanor Roosevelt in Hato Rey, San Juan (1937).	143
Figure 3.28	Suburban houses developed by the Puerto Rico Reconstruction Administration (PRRA) at the Urb. Eleanor Roosevelt in Hato Rey, San Juan (1937).	143
Figure 3.29	The house of architect Antonin Nechodoma in Miraflores, Santurce (built c.1913), example of the experimentation with early 'fair-faced' exposed concrete in Puerto Rico between the 1900 and 1940.	145
Figure 3.30	El Falansterio Housing, designed by Architect Jorge Ramírez de Arellano for the Puerto Rico Reconstruction Administration (PRRA) in 1937 example of the experimentation with early 'fair-faced' exposed concrete in Puerto Rico between the 1900 and 1940.	145
Figure 3.31		
Figure 3.32	Application of Portland cement stucco to concrete block masonry wall as outlined in the 1950s, which has not changed at all to present day standards. Source: Concrete Masonry Handbook for Architect, Engineers, Builders by the Portland Cement Association (1951), p. 45.	147
Figure 3.33	Common exterior stucco finishes in the 1960s. Source: Manual of Lathing and Plastering by John R. Diehl (1960), p. 122.	149
Figure 3.34	Cement Gun Company Bulletin issue from 1942. Source: Henry Klumb Collection, AACUPR.	153
Figure 3.35	St. John's Abbey Church at St. John's University in Collegeville, MN by architect Marcel Breuer features some architectural elements in which wet-mix shotcrete was used such as the reinforced, folder, plate roof truss. Source: Saint John's Abbey Church: Conservation, Restoration Preservation, Getty Foundation-Keeping it Modern: Planning, Final Report (July 2016), p. 135	158
Figure 3.36	Engineer A. Komendant included the use of shotcrete/gunite for developing thin shell roofs at the Del Carmen Church's first proposals. Source: A. Komendant, <i>Contemporary Concrete Structures</i> (McGraw-Hill) 1972, p. 501-504.	158
Figure 3.37	Dry-mix Plastering/Shotcrete machine in the 1960s. Source: <i>Manual of Lathing and Plastering</i> by John R. Diehl, 1960.	159
Figure 4.1	"Beautiful, Safe, Economic... and Maintenance Free!" Advertisement in the early 1960s of the Concrete Unlimited Company which marketed precast concrete elements. Source: <i>Revista Urbe</i> , c.1965, AACUPR.	171
Figure 4.2	Archival research at AACUPR on February 2020. Photo by E. García, 2020.	174
Figure 4.3	Sample construction drawing of a section of the church by H. Klumb from 1961. Source: AACUPR.	174
Figure 4.4	Final construction specifications for the Del Carmen Church from February 1961. Source: Henry Klumb Collection – AACUPR.	175
Figure 4.5	Conducting the aerial photographic survey of the building with Diana G. Serrano Miranda on December 24 <sup>th</sup> , 2019 and an aerial photo of the church facing the San Juan bay. Photos by D. Serrano Miranda, 2019.	176
Figure 4.6	Sample elevation drawings with notes and conditions marked during the on-site assessment. Drawings by H. Berdecía-Hernández, 2020.	178
Figure 4.7		
Figure 4.8	Condition issues on precast wall. Photos by Author, 2020.	179

Figure 4.9	stuccoed cast-in-place wall on the southeast side of the church. Photos by Author, 2020.	179
Figure 4.10	Examining the stuccoed wall on the north side of the church. Photo by C. Osorio.	180
Figure 4.11	Meeting with E. Vivoni, architect B. del Cueto, M. Frances-Gallart & Y. Hernández, AIT on January 11 <sup>th</sup> , 2020. Photo by Author, 2020.	180
Figure 4.12	Reinforced concrete block masonry walls at the Del Carmen Church. Graphics by Author, 2020.	182
Figure 4.13	Poured-in-place walls at the Del Carmen Church. Graphics by Author, 2020.	182
Figure 4.14	Precast panels at the Del Carmen Church. Graphics by Author, 2020.	183
Figure 4.15	Sealing roof paint & waterproof coating conditions at the Del Carmen Church. Photos	187
Figure 4.16	by Author, 2020.	
Figure 4.17	Del Carmen Church during construction in 1962. The variations on the stuccoed surfaces can be seen since the construction phase. Source: Henry Klumb Collection, AACUPR	194
Figure 4.18	Del Carmen Church before inauguration in 1963. The differences in the concrete masonry surfaces are evident vs. the dome finish. Source: Henry Klumb Collection, AACUPR.	194
Figure 4.19	Del Carmen Church before inauguration in 1963. The differences in stuccoed surfaces can be seen also in the bell tower. Source: AACUPR	195
Figure 4.20	Distribution of Elevations for the condition assessment for a total of 18 (including 3A, 3B, 6A, 6B, 10A & 10B); plus 11A, 11B & 11C, which are assigned for the belfry, and the six structural columns. Graphics by Author, 2020.	196
Figure 4.21	Structural columns at the Del Carmen Church identified for the conditions assessment. Graphics by Author, 2020.	197
Figure 4.22	Del Carmen Church c.1965. Extensive surface fouling issues in the form of black bio-growth has been present in the dome since its early days. Source: Henry Klumb Collection, AACUPR.	200
Figure 4.23	Del Carmen Church c.1999. Atmospheric soiling and bio-growth on the exposed	201
Figure 4.24	surfaces before the painting campaigns of the 2000s. Source: R. Otero	
Figure 4.25	Del Carmen Church in 2006. All the concrete and stuccoed exterior surfaces after the second paint campaign. The first paint campaign was applied between the late 1990s and early 2000s. Source: Madeline Ocasio, Flickr.	202
Figure 4.26	In the early 2010s the Church's administration installed pigeon netting along the	204
Figure 4.27	dome. Photos by Javier Freytes, 2019 & Author, 2020.	
Figure 5.1	Samples 1A (1A-1), 1A (1A-5), 2A (2A-1), 2B, 4 & 5. All cross-sections were examined at	221
Figure 5.2	1.0X, except 2A which was at 1.25X and Sample 5 at 0.71X. Photos by the Author.	
Figure 5.3		
Figure 5.4		
Figure 5.5		
Figure 5.6		
Figure 5.7	Samples 2A & 4 showing uncarbonated areas after the application of the	223
Figure 5.8	Phenolphthalein chemical indicator. Photos by Author.	
Figure 5.9	Preparation for the salt analysis included 50 mL water and powdered samples up to 10 g. Photo by the Author.	224
Figure 5.10	Sample preparation process included dissolving the powder in deionized water. In	225
Figure 5.11	samples 3B and 5 the deionized water turned pink after adding the powdered samples	
Figure 5.12	and after stirred by hand for 5 mins.	
Figure 5.13	Drops were applied to samples and glass plates (as control). The time was measured	227
Figure 5.14	with a chronometer. See Samples 2A & 1B. Photos by the Author.	
Figure 5.15	Sample preparation for the test. Results confirmed the presence of Iron on Sample 2A.	229
Figure 5.16	Photos by the Author.	

Figure 5.17	Configuration of a Polarized Light Microscope. Source: "Introduction to Polarized Light Microscopy," <i>BW Optics</i> , April 4 <sup>th</sup> , 2010 <a href="http://bwoptics.com/newsend2.asp?id=7">http://bwoptics.com/newsend2.asp?id=7</a> . Accessed on February 3 <sup>rd</sup> , 2020.	230
Figure 5.18	Examination of samples on the Polarized Light Microscope at the Penn Museum's Center for the Analysis of Archaeological Materials (CAAM). Photo by Dr. Boileau.	232
Figure 5.19	Hand specimens and Thin Sections from Samples 1A-1 to 2A-2. Photo by the Author.	233
Figure 5.20	Hand specimens and Thin Sections from Samples 2A-3 to 5. Photo by the Author.	233
Figure 5.21	Sample 2A-3 which is a troweled applied stucco with ferrous metallic aggregates/fillings shows a more compact microstructure and lower porosity compared to Fig 5.22. Photomicrographs from left (PPL) to right (XPL), magnification at 2.5x. Photo by Author.	234
Figure 5.22	Sample 1B which is a sprayed/shotcrete applied Stucco showing higher porosity (note blue dye). Photomicrographs from left (PPL) to right (XPL), magnification at 2.5x. Photo by Author.	234
Figure 5.23	Sample 2B shows poor bonding between the sprayed/shotcrete stucco and the poured-in-place concrete substrate. Note the surface interface voids. Photomicrographs from left (PPL) to right (XPL), magnification at 2.5x. Photo by Author.	235
Figure 5.24	Photomicrographs from left (PPL) to right (XPL) of the metallic ferrous (iron) filings in	236
Figure 5.25	Sample 2A-3 at 5x magnification (Upper) and 2.5x magnification (lower). Photo by the Author.	
Figure 5.26	Photomicrographs from left (PPL) to right (XPL) of Samples 2A-3 (Upper) and 1A-5	237
Figure 5.27	(Lower) both at 2.5x magnification. Sample 2A-3 shows two layers on the surface- one from paint and one from the asphaltic coating, while Sample 1A-5 shows only one layer of paint. Photos by the Author.	
Figure 5.28	Photomicrographs of Samples 3A (left) and 2A-2 both at magnification 2.5x. Calcium	238
Figure 5.29	carbonate in cement is present as clumps of crystals. As carbonation advances, those crystals form a dense texture darkening the paste and can be identified better in XPL. Photos by the Author.	
Figure 5.30	Shrinkage microcrack through the cement matrix surrounding the biogenic sand aggregate on Sample 1A-5 on PPL at magnification 20x. Photo by the Author.	238
Figure 5.31	Photomicrographs from left (PPL) to right (XPL) of Sample 4-1 (troweled stucco) showing a great amount of salt deposits on a void. Magnification at 10x. Photo by the Author.	239
Figure 5.32	Photomicrographs from left (PPL) to right (XPL) of Sample 3B (sprayed/shotcrete stucco) showing salt deposits on its voids. Magnification at 20x. Photos by the Author.	239
Figure 5.33	The computer and the MiniFlex 6G theta-2theta vertical goniometer benchtop powder	241
Figure 5.34	diffraction system (machine) at the Penn's Laboratory for Research on the Structure of Matter (LRSM). Photos by Author.	
Figure 5.35	Preparation of Samples for the XRD analysis included passing the powder through a	242
Figure 5.36	No. 50 Sieve. The results were passed to a data software for interpretation. Photos by	
Figure 5.37	Author.	
Figure 5.38	Several signals that are generated by the electron beam-specimen interaction in the SEM. Source: Zhou, Apkarian, Wang, and Joy, "Fundamentals of Scanning Electron Microscopy," 3.	245
Figure 5.39	Parts of a Scanning Electron Microscope (SEM). Source: Encyclopedia Britannica, Inc. (2012).	245
Figure 5.40	SEM micrograph on a metallic ferrous filing which confirmed to be Iron at .71x magnification using secondary electrons in Sample 2A-1. Photo by J. Ford.	247
Figure 5.41	Sample 2A-1 cross section with selected area before examination on the SEM on August 8 <sup>th</sup> , 2020. Photo by Author.	247
Figure 5.42	Sample 2A-1 cross section with selected area before examination on the SEM on September 8 <sup>th</sup> , 2020. Photo by J. Ford.	248



Figure 5.43	Sample 3A cross section with selected area before examination on the SEM on August 8 <sup>th</sup> , 2020. Photo by J. Ford.	248
Figure 6.1	Differences in the application of penetrants, film forming-sealants and coatings over concrete and Portland cement stuccoes. Source: David Odgers, ed., <i>Practical Building Conservation: Concrete</i> , (London, UK: English Heritage, 2012), 68.	262
Figure A2.1	Distribution of Elevations 1 & 2 with location of Figures A3.2 – A3.7. Graphics by Author, 2020.	322
Figure A2.2	Scaling and rising damp issues on Elevation 1. As the main entrance to the church, a big sign was originally installed using screws and eventually removed. At least two paint coatings could be identified in the wall. Photos by Author, 2020.	323
Figure A2.3		
Figure A2.4	Rising damp, discoloration and paint peeling issues on Elevation 2. Photos by Author, 2020.	323
Figure A2.5		
Figure A2.6	The wall is also affected by a small drainage in the curved eave which manage rainwater directly to the wall and concrete floor. A continuous horizontal crack in the wall surface is a sign of steel reinforce corrosion on the concrete masonry. Photos by Author, 2020.	324
Figure A2.7		
Figure A2.8	Distribution of Elevation 3 (3A & 3B) with location of Figures A3.9 – A3.12. Graphics by Author, 2020.	325
Figure A2.9	In elevation 3 two different paint coating applications can be found. A horizontal continuous slight crack along the concrete masonry wall show signs of steel reinforced corrosion. A vertical crack stained by mold is also seen on the top part of Side A. Photos by Author, 2020.	325
Figure A2.10	Water ponding due to the new drainage along poor water management issues have increased the chance of development of micro and macro biogrowth on Side B of Elevation 3. These include mold growth, leafy plants and insects living on scaled stucco. Photos by Author, 2020.	326
Figure A2.11		
Figure A2.12		
Figure A2.13	Distribution of Elevation 4 & 5 with location of Figures A3.14-A3.20. Graphics by Author, 2020.	327
Figure A2.14	Major scaling, rinsing damp and paint peeling issues can be seen in Elevation 4. Photo by Author, 2020.	327
Figure A2.15	Scaling along detachment/debonding and discoloration of stucco near the entrance in Elevation 4 (top left photo). Macro biogrowth and development of vertical and horizontal slight/hairline as sign of reinforced corrosion on Elevation 5 (top right and bottom photos). Photos by Author, 2020.	328
Figure A2.16		
Figure A2.17		
Figure A2.18	Two different paint coatings can be found on Elevation 5 along corroding nails and screws from an earlier sign (top photo). The original sign on the wall was installed in 2012 (bottom left photo) & removed c.2015 (bottom right photo). The original entrance signs are present in the 2015 photo. Photos by Author, 2020; Andrés Rivera, 2012 & Luis E. Carraza, 2015.	329
Figure A2.19		
Figure A2.20		
Figure A2.21	Distribution of Elevation 6 (6A & 6B) with location of Figures A3.22-A3.27. Graphics by Author, 2020.	330
Figure A2.22	Remaining palm trees and other large leafy plants close contact with the precast panels. The original paint from the church’s exterior surfaces is also visible from this side. Photo by Javier Freytes, 2019.	330
Figure A2.23	Del Carmen Church in 2017 before Hurricane María with all palm trees and vegetation. Source: Luis E. Carrazo, 2017.	331
Figure A2.24	Soiling and mold issues on the surfaces of the precast panels on Side B (left photo).	331
Figure A2.25	Diagonal slight cracking due to steel corrosion on Side A of the precast panels (right photo). Photos by Author, 2020.	
Figure A2.26	Cracking issues along the precast members of Elevation 6. Photos by Author, 2020.	332
Figure A2.27		
Figure A2.28	Distribution of Elevation 7 with location of Figures A3.29 – A3.31. Graphics by Author, 2020.	332

Figure A2.29	Slight vertical cracking, paint peeling and soiling issues on the eaves of Elevation 7. Photos by Author, 2020.	333
Figure A2.30 Figure A2.31	Scaling of stucco and corrosion staining over the surfaces of Elevation 7. Photos by Author, 2020	333
Figure A2.32	Distribution of Elevation 8 (8A & 8B) with location of Figures A3.33 – A3.35. Graphics by Author, 2020.	334
Figure A2.33	Surface fouling and paint peeling/deterioration on Elevation 8 (top photo). Photo by Author, 2020	334
Figure A2.34	Detaching/debonding areas with small hairline diagonal cracks on the stuccoed tilted wall on Elevation 8. Photos by Author, 2020.	335
Figure A2.35	Vertical and horizontal microcracking, paint peeling and moisture issues on the surfaces of the dome on Elevation 8. Photo by Author, 2020.	335
Figure A2.36	Distribution of Elevation 9 with location of Figures A3.37-A3.40. Graphics by Author, 2020.	336
Figure A2.37	Current condition of the roof slabs on the west side of the church - Elevation 9. Photo by Author, 2020.	336
Figure A2.38	Broken 'Type A' original roof drainage on roof slab near baptistry and confessionary – East side (bottom photo). Photo by Author, 2020	337
Figure A2.39 Figure A2.40	A broken drainage from building on the west side of the church creates a massive water ponding issue on the roof slab. The two original 'Type B' drains are not working (left photo). New installed drainage which leads to water ponding, increasing moisture and bio-growth issues on Elevation 3. This new drainage is the only one properly functioning on the roof (right photo). Photos by Author, 2020.	337
Figure A2.41	Distribution of Elevations 10A & 10B with location of Figures A3.42 – A3.45. Graphics by Author, 2020.	338
Figure A2.42 Figure A2.43	The original glass louvers can be found at the roof (left photo). Cracking, an improper repair and discoloration of the eaves in Elevation 10A (right photo). Photos by Author, 2020.	338
Figure A2.44 Figure A2.45	Major paint peeling, cracking and improper repairs in Elevation 10B. The sealing grey coating has also been applied to these concrete elements with a new paint coating of painting. Photos by Author, 2020.	339
Figure A2.46	Distribution of Elevation 11 (11A, 11B & 11C) with location of Figures A3.47 – A3.50. Graphics by Author, 2020.	339
Figure A2.47 Figure A2.48	Diagonal cracking, discoloration, scaling and paint peeling issues on reinforced concrete masonry belfry. Photos by Author, 2020.	340
Figure A2.49 Figure A2.50	Improper repairs, paint peeling, discoloration, humidity and possible alkali-silica reaction (ASR) issue on Elevation 11C of the belfry. Photos by Author, 2020.	340
Figure A2.51	Distribution of Elevation 12 with location of Figures A3.52 – A3.55. Graphics by Author, 2020.	341
Figure A2.52	The application of a sealing coating to the stuccoed wall is causing moisture, bio-fouling and discoloration issues. Photos by Author, 2020.	341
Figure A2.53	Bio-fouling growth and atmospheric soiling issues on the lower side of Elevation 12. Photos by Author, 2020.	342
Figure A2.54 Figure A2.55	Horizontal and vertical highline cracks, minor detachment/debonding sections and scaling along the surfaces. Photos by Author, 2020	343
Figure A2.56	Distribution of Elevation 13 with location of Figures A3.57 – A3.59. Graphics by Author, 2020.	343
Figure A2.57 Figure A2.58 Figure A2.59	Highline cracks along discoloration sections and scaled portions of the stucco in Elevation 13 (top photos). Original stucco patches -now covered- show the uneven workmanship over the exposed surfaces. Photos by Author, 2020.	345
Figure A2.60	Distribution of Elevation 14 with location of Figure A3.61. Graphics by Author, 2020.	346
Figure A2.61	A diagonal slight crack and soiling are among the conditions in Elevation 14. Photos by Author, 2020.	346

Figure A2.62	Distribution of Elevation 15 with location of Figures A3.63 & A3.64. Graphics by Author, 2020.	347
Figure A2.63 Figure A2.64	Large scaled stuccoed surfaces, fouling and guano issues on Elevation 15. Photos by Author, 2020	348
Figure A2.65	Distribution of Elevation 16 with location of Figures A3.66 – A3.69. Graphics by Author, 2020.	349
Figure A2.66 Figure A2.67	Elevation 16 showed some scaling and detachment/debonding conditions. Fouling and deterioration under the stucco layer is particularly visible in this section of the Elevation (left photo). Guano and soiling issues on the wall and a broken pigeon netting (right photo). Photo by Author, 2020.	349
Figure A2.68 Figure A2.69	Cracking, scaling, guano, mold growth, fouling and moisture issues on Elevation 16. The roof sealing and waterproof coating was also applied to the base of the wall. Photo by Author, 2020.	350
Figure A2.70	Structural column A with location of Figures A3.71 – A3.73. Graphics by Author, 2020.	351
Figure A2.71 Figure A2.72	Discoloration, fouling and paint peeling conditions on Column A (left). Small detachment/debonding area behind Column A (right). Photos by Author, 2020	351
Figure A2.73	Discoloration, fouling and paint peeling conditions on Column A. Photo by Author, 2020	352
Figure A2.74	Structural column B with location of Figures A3.75 -A3.78. Graphics by Author, 2020.	352
Figure A2.75 Figure A2.76	Detachment/debonding areas on the back of Column B. Other conditions include scaling, discoloration, fouling, mold growth and paint peeling. A corroded electrical metallic socket can be seen on the lower part of the column. Photos by Author, 2020.	353
Figure A2.77 Figure A2.78	The roof sealing paint was applied to the base of both Column B and Column A. Also, the gray sealing coating was applied in the upper parts of the column (see the differences in layers). Photos by Author, 2020.	353
Figure A2.79	Structural column C with location of Figures A3.80 – A3.82. Graphics by Author, 2020.	354
Figure A2.80	Scaling and fouling issues on Column C. Photo by Author, 2020.	354
Figure A2.81 Figure A2.82	Surface fouling, mold growth and paint peeling on Column C (left photo). Small detaching/debonding areas on the base of Column C (right photo). Photos by Author, 2020.	355
Figure A2.83	Structural column D with location of Figures A3.84 – A3.86. Graphics by Author, 2020.	355
Figure A2.84	Possible alkali-silica reaction (ASR) on stucco at the base of Column D. Common visual identification of this condition includes crazing surrounded by moisture and discoloration patterns, and efflorescence. Photo by Author, 2020.	356
Figure A2.85 Figure A2.86	Fouling, mold growth and scaling of the surfaces along Column D (left photo). The largest detaching/debonding area on a structural column in the Church is seen on the back of Column D Photos by Author, 2020.	356
Figure A2.87	Structural column E with location of Figures A3.90 – A3.92. Graphics by Author, 2020.	357
Figure A2.88 Figure A2.89	Trees and vegetation area between Columns E & and Elevation 13 in 2012. Photos by Andrés Rivera, 2012.	357
Figure A2.90	Small leafy plants growing along the stuccoed surfaces of Column E. Photos by Author, 2020	358
Figure A2.91 Figure A2.92	Scaling and leafy plants growing on the stucco surfaces of Column E. Lamps have been installed on Columns D, E and F, attaching them to the stuccoed surfaces. Photos by Author, 2020.	358
Figure A2.93	Structural column F with location of Figures A3.94, A3.96 & A3.97. Graphics by Author, 2020.	359
Figure A2.94	The installation of bird spikes with this silicone adhesive was used between the stuccoed surfaces of the tilted walls and columns C, D, E & F. Photo by Author, 2020.	359
Figure A2.95 Figure A2.96 Figure A2.97	A failing previous repair behind Column F (top left photo). Fouling, scaling and vertical/horizontal cracking issues on the top of Column F (top right and bottom photos). Photos by Author, 2020.	360

Figure A3.1	Observed Annual Precipitation. Source: NOAA National Centers for Environmental Information, State Climate Summaries: Puerto Rico / CICS-NC and NOAA NCEI.	361
Figure A3.2	Average Annual Climate. Source: NOAA Climate Data Handbook.	362
Figure A3.3	Wind Summary. Source: NOAA Climate Data Handbook.	363
Figure A3.4	Wind Summary. Source: NOAA Climate Data Handbook.	364
Figure A3.5	Source: Solar Radiation Data Manual for Buildings, National Renewable Energy Laboratory (NREL), September 1995.	365
Figure A3.6	Source: NOAA Climate Data Handbook.	366
Figure A13.1	Location of the Puerto Rico Cement Corp. at the Barrio Amelia near Cataño. Source: M. H. Pease, Dr. and W. H. Monroe, Geologic Map of the San Juan Quadrangle, Puerto Rico, U.S. Geological Survey, 1977.	432
Figure A13.2	Location of the Ponce Cement Corp. Source: Krushensky, R. and Monroe, W. Geologic Map of the Peñuelas and Punta Cuchara Quadrangles, Puerto Rico, U.S. Geological Survey, 1978.	433
Figure A16.1	Drawing-Perspective of the Del Carmen Church. Source: Henry Klumb Collection, AACUPR	516
Figure A16.2	Book Review of 'Architecture in Puerto Rico' featuring the Del Carmen Church at the San Juan Star Magazine on July 25, 1965, p. 6. Source: Henry Klumb Collection, AACUPR.	516
Figure A16.3	Article featuring the construction of the Del Carmen Church in El Mundo Newspaper, May 26 <sup>th</sup> , 1962. Source: Henry Klumb Collection, AACUPR.	517
Figure A16.4	Del Carmen Church featured in the <i>Progressive Architecture</i> issue from November	518
Figure A16.5	1963. Source: Henry Klumb Collection, AACUPR.	519
Figure A16.6	Del Carmen Church featured at the AIA Journal issue of July 1974. Source: JoAnn Crisp-	520
Figure A16.7	Ellert, "Henry Klumb in Puerto Rico: Architecture at the Service of Society," <i>AIA Journal</i> , July 1974, p. 50-53.	521
Figure A16.8	Del Carmen Church featured in the international <i>CALLI</i> magazine issue of March-April	522
Figure A16.9	1967. Source: <i>CALLI: Revista Analítica de Arquitectura Contemporánea</i> , March-April	523
Figure A16.10	1967, p. 49-51. Henry Klumb Collection, AACUPR.	524
Figure A16.11	Del Carmen Church featured in the <i>URBE</i> magazine issue of December 1968-January 1969. Source: Efraín E. Pérez Chanis, "Arquitectura Religiosa en Puerto Rico," <i>URBE</i> , No. 32, December 1968-January 1969, p. 21, Henry Klumb Collection, AACUPR.	525
Figure A16.12	Del Carmen Church featured at the MoMA Exhibition publication Latin America in Construction: Architecture 1955-1980. The exhibition was held from March 29 <sup>th</sup> -July 19 <sup>th</sup> , 2015. Barry Bergol, Carlos Eduardo Comas, Jorge Francisco Liernur and Patricio del Real, eds. <i>Latin America in Construction: Architecture 1955-1980</i> (New York, NY: MoMA Publications, 2015), 155.	526
Figure A16.13	Del Carmen Church featured as an example of a successful passive ventilation system by a monthly publication of the Office of Energy Affairs of Puerto Rico in Feb 1982. Source: "La obra ejemplar de Henry Klumb: Un ejemplo vivo de la Arquitectura Tropical," <i>Cuentagotas</i> 4, No. 2, Oficina de Energía de Puerto Rico, February 1982, p. 45; Henry Klumb Collection, AACUPR.	527
Figure A16.14	The original Del Carmen Church design featured in the <i>Progressive Architecture</i> issue from October 1960. Source: Henry Klumb Collection, AACUPR.	528
Figure A16.15	Building description documents from 1963. Source: Henry Klumb Collection, AACUPR.	529
Figure A16.16		530
Figure A16.17		531
Figure A17.1	Letter from the Government of Puerto Rico-Institute of Puerto Rican Culture's Built Heritage Program. Source: Archives of the Built Heritage Program, Institute of Puerto Rican Culture.	532

## LIST OF TABLES

Table 5.1	General Sample Schedule	218
Table 5.2	Samples for Petrographic Analysis	231
Table 5.3	Composition of Stucco in Specs vs. Testing Results	249
Table A2.1	Conditions per Elevation	318
Table A5.1	Total Collected Samples	369
Table A7.1	Testing Matrix	385
Table A8.1	Stereomicroscope observations	390
Table A9.1	Carbonation results	404
Table A10.1	Results of the Microdrop Water Absorption Test	410
Table A12.1	Semi-Quantitative Salt Analysis Results	416

## INTRODUCTION

"Ultimately, it is only the surface which is decisive for architecture. Human beings do not live in designed and constructed buildings, but rather in the atmosphere created by the architectural surface." - Theo van Doesburg, (1929)<sup>1</sup>

"Modernism both the genesis and the *bête noire* of historic preservation."<sup>2</sup>

As a twentieth-century phenomenon, modernist architecture of the mid-century cannot be fully understood without an understanding of the dominant role materials and new technologies played, in this case, concrete. Over the last two decades, discussions about modern architecture have struggled with several issues related to its preservation: representation, integrity, and sustainability. Nevertheless, modern architecture has been gaining recognition as part of our common built heritage, and thus it now needs to be preserved and protected.<sup>3</sup> However, the study of the Modern Movement in architecture has privileged aesthetic-visual narratives, leaving the analysis of construction technologies and materials behind. As an example, traditional historiography of the Modern Movement does not place attention at all on the variety of applied architectural surface finishes even when they were widely used by architects of the era, creating a misrepresentation of the prevalent use of white flat painted surfaces and exposed concrete.<sup>4</sup> The lack of technical research has prevented accurate restoration and a loss, a deeper understanding of the period.

Even though the research regarding the materials and technologies of the Modern Movement is still a development area, it has attracted a great range of architects, engineers, conservators, and historians over the past few decades. Efforts on the development of a concrete conservation field have also helped initiate discussions about current and growing needs for conservation approaches on the analysis and treatment of historic concrete, an area traditionally dominated by the concrete repair industry.

*Understanding and caring for the "yet not loved."*

One of the main issues with modern heritage until recently has been its negative reception by the public. This issue has allowed a lack of care and appreciation, and thus lack of research given the assumption that the materials and methods are the same as currently practiced. This issue is not foreign to Puerto Ricans, who do not see their infrastructure, in place for six decades, as part of the collective heritage such as Old San Juan.<sup>5</sup>

Another common discussion related to the "recent past" of modernist architecture is the architect's intent and how spatial functionalism plays a crucial role in these buildings. This raises questions on integrity and how this is considered when a modern building is altered, repaired, and/or restored. Another issue has been the use of innovative and experimental construction technologies of the era, which sometimes featured a limited lifespan and often represent conservation challenges and high costs.<sup>6</sup> As experimental, these construction technologies also featured a poor understanding of the materials and their overall performance. For example, modern-era buildings have been characterized by poor drainage and water management issues, and concrete was promoted as a maintenance-free material.<sup>7</sup> Also, the appearance of building materials and the expectation of newness affects the perception of modern buildings, especially when they weather. The use of exposed concrete and rough concrete finishes in modern buildings is a good example. These are prone to showcase weathering patterns or imperfect surfaces ending up being painted, affecting their appearance and integrity.

As an emerging field since the 1980s, the study of concrete performance and repair in buildings, but specifically in historic buildings, is still one of the most discussed issues. As an example, concrete repair standards often seek to replace the material rather than preserve it. Furthermore, the absence of targeted concrete standards and

investigations on performance in the tropics presents another challenge for modern concrete buildings, especially in the Caribbean region. This has allowed a wide range of problems such as the continued practice of improper repairs and cleaning treatments, along with lack of skilled craftsmen, affecting for decades the region's vulnerable concrete heritage. In Puerto Rico, the lack of a professional field in traditional conservation has led to modern buildings being repaired using contemporary and often incompatible methods. Still, "...The Twentieth Century was characterized by innovative forms, [experimental] structural solutions, buildings materials, and construction techniques," and concrete as versatile and cheap as it was, the material which best represented and realized modern desires.<sup>8</sup>

#### *Concrete modernism in the Caribbean: Del Carmen Church*

Much has been written about the history and ideologies of modern architecture in the Spanish Caribbean. Yet, a fuller, more nuanced understanding of its regional expressions will only be revealed through an in-depth study of each building that contributed to its development. Modern architects such as Henry Klumb showcased concrete in its plastic and structural potential on projects such as the Parroquia Nuestra Señora del Carmen. The Del Carmen Church, built between 1961 and 1962, showcases many of the issues that modern building faces: from its recognition as a heritage building, to changes in functional spaces and integrity, to technical-material issues. In this sense, Henry Klumb's Del Carmen Church in Cataño, Puerto Rico, exemplifies how common conservation issues for modern heritage, such as design intent, authenticity, and material realities are global concerns, and how informed scientific investigations can aid in better interpretation and conservation.

The Parroquia Nuestra Señora del Carmen was founded in 1893 in the coastal town of Cataño, just outside San Juan, Puerto Rico. In 1957, the Dominican Catholic Order



commissioned architect Henry Klumb to design a modern Church, which was inaugurated in June 1962. The new Church was to serve as the town's Parochial church with a capacity of 500 people. Since its opening, the Del Carmen Church has remained relatively unchanged. Yet, efforts to maintain and 'improve' the building over the years, including painting the original exposed cement stucco exteriors and the removal of the central altar, have contributed toward a misunderstanding and underappreciation of one of Klumb's most significant works on the islands.

Considering Del Carmen Church as a case study, this thesis proposes to present Henry Klumb's original design intent for the Del Carmen Church and its subsequent alterations over time and characterize and assess the current conditions of the concrete and especially the cement stucco exterior; an essential character-defining feature of its design, in the tropical coastal environment of Puerto Rico. Lastly, this research will conclude with recommendations for its conservation and maintenance.

The study was comprised of four phases: Firstly, an in-depth analysis of archival research records of the building, its design, the historical context, and its construction and maintenance, using the resources principally at the University of Puerto Rico Architecture and Construction Archives (AACUPR by its acronym in Spanish).<sup>9</sup> The second phase includes a Conditions Survey and Assessment with a detailed focus and evaluation of the exterior Portland cement stucco. The third phase focuses on the Physico-chemical analysis of selected samples from the cement stucco and the concrete substrates. For this phase, microscopy and instrumental analysis provided valuable information about the composition of the stucco. These include petrography, micro-drop water absorption testing, microchemical spot test, salt content, carbonation testing, x-ray diffraction (XRD), and scanning electron microscopy with energy dispersive x-ray spectroscopy (SEM-EDS). Lastly, Phase four recommends a cleaning program to determine the best treatment

options for removing the current painted coatings without affecting the cement stucco and aiding the building's restoration to its original exposed stucco surfaces. Some consideration and discussion with stakeholders, including the congregation, will be necessary for the final exterior and the desire for a unified appearance.

The Parroquia Nuestra Señora del Carmen in Cataño was widely published in the 1960s and is one of the three exemplary mid-century modern Catholic churches designed by Henry Klumb between the late 1940s and early 1960s. No historic research or historical designation has been prepared for the site. The methodology used for this comprehensive study on the cement stuccoes and recommended cleaning treatments will prove to be a useful restoration approach and an option to current cleaning methods, which are typically incompatible with heritage conservation practices.

As Wells mentions, "...very little has been written on the building materials of the Caribbean and their relevance to architectural history, cultural studies, and site preservation and restoration." Considering the current needs of the region and how very few resources discuss the technical necessities of modern religious architecture, this thesis aims to inform better conservation and restoration practices for exposed concrete buildings in Puerto Rico and the Caribbean by showcasing the Parroquia Nuestra Señora del Carmen as a case study.<sup>10</sup>

As a case study, the Del Carmen Church presented an opportunity to examine closely common issues of modern heritage while proposing the preservation and restoration of the Church to its original appearance. These issues included:

1. Needs of historic concrete
2. An examination of concrete performance in a tropical environment
3. The construction technologies and concrete finishes used by architect Henry Klumb

4. The assessment of the significance of an obscure heritage site relevant to Puerto Rico, Cataño, and internationally, from its architectural fabric and character-defining features to its intangible historic, social, and cultural significance.
5. Considering the architect's original intent to restore the exterior, since the Church was painted in the early 2000s because of weathering pattern issues and the leached surfaces.
6. How a planned and informed conservation appraisal/analysis guides the decision-making process for all historic preservation projects, including not replacing the original fabric but restoring it. For the Del Carmen Church, even if there was a wide range of archival records, the scientific analysis proved that these were different from the actual execution.
7. Research on Portland cement stucco and its use on mid-century modern architecture, at a time when fair-faced concrete was popular.
8. Changes in the functionality of the Church's original space since the initially centered altar was demolished and moved to the back of the nave.

## Endnotes

---

<sup>1</sup> Ivo Hammer, "The Original Intention – Intention of the Original?: Remarks on the Importance of Materiality Regarding the Preservation of the Tugendhat House and other Buildings of Modernism," in D. Van Den Heuvel, M. Mesnan, W. Quist & B. Lemmens, eds., *Challenge of Change: Dealing with the Legacy of the Modern Movement- Proceedings of the 10<sup>th</sup> International DOCOMOMO Conference*, (Amsterdam: Delft University Press & IOS Press, 2008), 369.

<sup>2</sup> Thomas C. Jester and David N. Fixler, "Modern Heritage: Progress, Priorities, and Prognosis," *APT Bulletin: The Journal of Preservation Technology* 42, No. 2/3 (2011): 3.

<sup>3</sup> Hammer, "The Original Intention....," 369.

<sup>4</sup> *Ibid.*, 370.

<sup>5</sup> In many countries, post-World War II led to an era of economic progress and innovation, including the building of massive infrastructure programs for the society such as housing, commercial architecture, public buildings and churches. In Puerto Rico this socio-economic phenomenon took place along important political changes, so it led to the development of a major infrastructure that is still in place now.

---

<sup>6</sup> Susan D. Bronson and Thomas C. Jester, "Conserving the Built Heritage of the Modern Era: Recent Developments and Ongoing Challenges," *APT Bulletin: The Journal of Preservation Technology* 28, No. 4 (1997): 4.

<sup>7</sup> Kiran Joshi, Ed., *Corbusier's Concrete: Challenges of Conserving Modern Heritage-Proceedings of Seminar on Conservation of Le Corbusier's Work in Concrete, Chandigarh*, 11-13 February 2002 (Chandigarh, India: Chandigarh Perspectives/Chandigarh College of Architecture, 2005), 15.

<sup>8</sup> ICOMOS International Committee on Twentieth Century Heritage (ISC20C), *Approaches to the Conservation of Twentieth-Century Cultural Heritage: Madrid-New Delhi Document*, ICOMOS- International Committee on Monuments and Sites (2007), 4.

<sup>9</sup> The University of Puerto Rico Architecture and Construction Archives (AACUPR) host the Henry Klumb Collection with more than 320 projects from the architect's office between 1945 and 1984. Enrique Vivoni Farage, "Henry Klumb y la Exuberancia poética en la Arquitectura/Henry Klumb and Poetic Exuberance in Architecture" in *Klumb: Una arquitectura de impronta social/An Architecture of Social Concern* (San Juan, PR: Editorial UPR, 2006), 32.

<sup>10</sup> Despite the breakthrough of religious architecture in the international Modern architecture movement, there is few researches related to modern Latin American and Caribbean churches. In Puerto Rico, investigations related to ecclesiastical architecture focuses on historical and aesthetical merits, often privileging pre-1900 churches, and leaving behind other crucial areas such as building technology, uses, social history and liturgical aspects. Architect Héctor Balvanera provides a good overview on the state of literature related to Latin American and Puerto Rican religious modern architecture. See Héctor Balvanera Alfaro, "Arquitectura Religiosa de las Parroquias de la Arquidiócesis de San Juan de Puerto Rico, 1965-1995" (Master's thesis, Universidad Popular Autónoma del Estado de Puebla, 2019).

## CHAPTER 1

### Concrete and ‘*Modernity*’ in Puerto Rico

“...in the discovery and colonization of new lands, the settlers have imported the products of the mother country with which they were familiar. But with the wider circulation of knowledge since the advent of steam power, the printing press, the photographic camera and the harnessing of electricity the limitations that generally confined our ancestors to the selection of home-made building material have been largely removed...” – Oswald C. Hering in *Concrete & Stucco Houses*, 1912, 20.

Puerto Rico, considered the smallest of the Greater Antilles, is an archipelago located in the northeastern Caribbean Sea.<sup>1</sup> For over 400 years, Puerto Rico was a colony of the Spanish empire. In July 1898, during the Spanish-American War, the United States invaded and took possession of Puerto Rico, Guam, Cuba, and the Philippines, all of which eventually became US territorial possessions.

As part of the American imperial expansion project, Puerto Rico and its fellow territories/colonies in the Pacific and the Caribbean became an ideal laboratory for testing new social, political, and economic institutions and ideas. Fueled by the notions of ‘progress’ and American exceptionalism and an economic windfall, the growing Portland cement industry quickly established itself as a critical component in the island’s development, especially architecture and civil engineering.<sup>2</sup> Portland Cement was patented in England by John Aspdin in 1824, and by the late nineteenth century the material -in the form of concrete- became a “symbol of a new and prosperous civilization.”<sup>3</sup> The building industries would frame the era as the “Concrete Age,” proven by the rising consumption of Portland cement in the U.S. from 990,324 bbl (barrels) to 22,342,973 bbl in a few short years between 1890 and 1903.<sup>4</sup> Portland cement, an artificially produced compound that began as an imitator of natural stone, became the product of choice to disseminate new architectural and engineering ideas and forms in the new colonial possessions.<sup>5</sup>

In this sense, Portland cement and reinforced concrete were the ideal building materials for the newly acquired overseas American colonies.<sup>6</sup> Quickly replacing local construction methods based on labor-intensive rubble masonry (*mampostería*) and vulnerable vernacular wood and thatch frame, reinforced concrete offered permanence in the 'extreme' environment of the tropics, which included cyclical adverse weather conditions, termites, and natural disasters.<sup>7</sup> As a result of its survival and resistance to these environmental 'threats,' reinforced concrete, as a building technology, became a durable alternative for buildings and helped provide the economic stability and unobstructed progress that the newly imported capitalist economic model (the arrival of American companies, insurance companies, and open market) would bring.<sup>8</sup>

Puerto Rico, as a strategic military possession of the U.S. in the Caribbean -a gateway to the Atlantic Ocean and Europe-, as well as offerings proximity to the Panama Canal, was the perfect place to experiment with reinforced concrete since it was ideal for the necessary port infrastructure that would further serve the economic and military interests of the United States. In the early twentieth century, Portland cement and concrete were seen as a 'sanitary and hygienic materials' that did not need much maintenance, in contrast with the 'unsanitary' thatched wood *bohío* dwellings for thousands of poor Puerto Ricans.<sup>9</sup> The *bohíos* (thatch dwellings), along with other construction technologies such as rammed earth (*Tapia*), as well as brick, rubble (*mampostería*), and ashlar masonry (*Silar*), prevalent for over 400 years in the Islands, were perceived not only as backward and anti-modern but as representative of the old Spanish regime by the new authorities.<sup>10</sup>

Since the early twentieth century and into the late 1940s, Portland cement and reinforced concrete technologies played a prominent role in developing a modern and 'progressive' architecture of the Islands. This transition to a radically different use of architectural materials and building technologies opened new possibilities that sparked

architectural creativity. In the mid-twentieth Century, designers could use one material to combine load-bearing-structural capacity with the possibility of creating diverse spatial shapes and aesthetic surface qualities, something that had been almost impossible with construction materials from previous eras, which were dependent on assembly elements.<sup>11</sup> Reinforced concrete, originally used as a substitute and structural material, became increasingly exploited for its possibilities in architectural expression.

But how did both Portland cement and reinforced concrete shaped the Puerto Rican built environment in the twentieth century? Since 1899, at the same time the U.S. production of hydraulic cement peaked, the new American colonial government sought the military and economic control of Puerto Rico.<sup>12</sup> These socio-economic structural issues exacerbated the living conditions of millions of Puerto Ricans during the first half of the twentieth century. If the Great Depression of 1929 had disastrous economic and social effects on the United States, for Puerto Rico (as a territory), it was a nightmare. As a mostly agrarian society with land ownership in the hands of American foreign corporations, the majority of Puerto Ricans lived in poverty. To alleviate the socio-economical situation, between the 1930s and the 1960s, three specific political-economic projects, aided by the federal government, were established by the Insular Government. These projects played a crucial role in promoting the use of Portland cement and reinforced concrete to help attain 'a modern society' in the Islands. They were: the Puerto Rico Reconstruction Administration (PPRA) and the Plan Chardón in the 1930s, Governor Rexford G. Tugwell's and the WWII Projects of the 1940s, and lastly, Operations Bootstrap and the Estado Libre Asociado (Commonwealth) from the late 1940s through the 1960s. While these projects allowed the Modern Movement to take root on the island, the development and use of Portland cement and reinforced concrete can be traced earlier to the second half of the nineteenth century.<sup>13</sup>

### 1.1.1 *Early Introduction of Cement in Puerto Rico*

The use of hydraulic mortars in Puerto Rico is not a foreign practice.<sup>14</sup> During the more than 400-year Spanish rule, Roman construction traditions (mostly from southern Spain) incorporated the use of natural hydraulic mortars. These lime mortars with additives such as brick dust produced a mix known as *argamasa* suitable for long-standing structures (primarily those built of brick, rubble, and ashlar masonry) in tropical environments since they hardened or set in contact with water.<sup>15</sup> As building technologies developed over the centuries, sometime during the second half of the nineteenth century, the use of another hydraulic -albeit artificially produced material, early Portland Cement or 'artificial or plastic stone,' was introduced and readily used in a range of public and private projects.<sup>16</sup>

The nineteenth-century represented an era of significant political, social, and economic changes in Puerto Rico. The Islands opened to international trade and commerce (which included the United States); the population grew, foreign capital investments and commercial trade rose, and the Spanish Crown's interest in keeping one of its last possessions in the New World led to ambitious infrastructure planning.<sup>17</sup> Amongst these socio-economic changes, Portland Cement began to be imported and extensively used in Puerto Rico. Usually shipped from Belgium, Denmark, and Germany, it came to the region through the free port of the Danish West Indies (today the U.S. Virgin Islands).<sup>18</sup> During the late nineteenth century, Portland Cement was commonly used in small-scale civil engineering projects in Puerto Rico. Cement was also used as a binder for mortars and renders, as well as for bridge foundations, roads, walkways, and infrastructure, especially where water resistance was needed.<sup>19</sup> Projects such as the Acueducto de San Juan/San Juan Aqueduct used hydraulic stucco layers, including early



Portland cement, covering the massive underground stone cisterns-walls.<sup>20</sup> Puerto Rican masons continued using hydraulic cement mortars for structural purposes but also were skillful in their application for exterior finishes mortars as well.



*Fig. 1.1– Acueducto de Río Piedras/Río Piedras Aqueduct. At the time it had three enormous water tanks and an Industrial Mechanical Warehouse. The Aqueduct could filter more than 500,000 gallons of water daily at the time. Source: Puerto Rico Ilustrado, 1919.*

### *1.1.2 Twentieth-Century Development of Reinforced Concrete in Puerto Rico*

Although the use of Portland Cement and reinforced Concrete in the late nineteenth century and early twentieth century was considered a ‘miracle material’ that would solve all the issues faced by the construction industry of the period, these were still experimental trials. The development of innovative and successful building technologies helped establish their popularity globally.<sup>21</sup> The early use of reinforced concrete in Puerto Rico during the twentieth century came from both the federal and insular governments (with its regulations, requirements, market demand, and increased commercial trade with

the U.S.), the influence and tastes of the private sector, evolving architectural styles, new products, and professionals willing to experiment with these.

The Spanish-American War boosted the development of the U.S. Portland Cement industry and increased its domestic use.<sup>22</sup> At the same time, the U.S. Congress established a Civil Government with the enactment of the Foraker Act of 1900. This new civil government made its priority an ambitious infrastructure program of roads, bridges, and public buildings, especially after the devastation caused by Hurricane San Ciriaco in 1899. Many of these projects used imported Portland Cement products, all introduced by the military, the US federal government, and protestant religious groups. As control over Puerto Rico became their primary goal, reinforced and unreinforced concrete institutional buildings, schools, and housing quickly forged the image of a new era, all part of an intended assimilation project.<sup>23</sup>

Both federal and local governmental agencies promoted the use of Portland cement and reinforced concrete in this era. The Insular government created a Department of the Interior and a Bureau of Public Works that would be in charge of all public infrastructure, while the Office of the Commissioner of Education was to oversee the construction of dozens of schools around the Islands using early hollow concrete blocks.<sup>24</sup> The newly established open trade between Puerto Rico and the United States allowed the untaxed importation of American cement to the Islands.<sup>25</sup> As Luis Pumarada O'Neill states, "American sovereignty allowed the untaxed importation of American cement at the precise point in time in which reinforced concrete technology was coming of age."<sup>26</sup> Likewise, the arrival of American construction firms to Puerto Rico for these and other projects helped to disseminate the use of Portland cement technologies such as reinforced concrete and early concrete blocks.<sup>27</sup>


In the end, the use of Portland Cement and reinforced concrete was promoted in the early twentieth century by the Federal and Insular Government, the protestant missionaries, and the wealthy elite who first developed the growing suburb of Condado.<sup>28</sup>



*Fig. 1.2– The Federal Building and U.S. Courthouse in Old San Juan, built-in 1914, was the first and most expensive federal building constructed in Puerto Rico during this period. As the southern edge of an old ashlar, rubble and brick masonry city, the building was a symbol of the new colonial order which used the reinforced concrete system. Source: H. Santiago and F. J. Del Campo, “US Post Office and Courthouse/Old San Juan Federal Building” *National Register of Historic Places Inventory/Nomination Form*, March 28th, 1988.*

ESCUELA "ROMAN BALDORIOTY DE CASTRO"

Archivo Historico de P. R.  
San Juan, P. R.



Construida por Mr. F. P. HATCH exclusivamente con

**Cemento ATLAS**  
EN SACOS

Mas de 60,000 sacos de Cemento ATLAS usados  
en esta obra con éxito asombroso.

MATERIAES DE CONSTRUCCION EN GENERAL.

ENVIE SUS PEDIDOS A

**Sobrinos de Ezquiaga**

TELEFONOS: 32, 18 y 58. ALLEN 17. APARTADO No. 531.  
SAN JUAN, P. R.



**The Board of Education in Porto Rico adonts THE HERCULES**

If you are making Concrete Blocks you ought to have the Hercules, the best machine; it may cost you a little more at the start, but it will prove the most economical before six months have passed.

The Board of Education has adopted the Hercules for Concrete Construction of all kinds in Porto Rico as this letter will prove:

"GENTLEMEN:—Last machine ordered for Board of Education has arrived. The department will adopt the Hercules Concrete Block almost universally. Both the Commissioner and the Superintendent of Construction in this department seem very enthusiastic about it. They have already contracted for three or four buildings to be built, and some of them I shall build myself. I contracted for the first one and am now having plans drawn for three new churches, all to be made of blocks, and am putting up a large apartment house which I shall send you a photo of when completed."

Every intelligent contractor ought to have a Hercules Machine. You can make blocks with other machines, but you cannot make the variety of blocks necessary to build a beautiful building, and on no other machine can you make a REAL Concrete Block—that is a wet mixture block of coarse material.

The Hercules is the strongest of all machines—it is constructed on the most simple lines. No chains, gears, levers, springs or pins—nothing about the Hercules to get out of order. It is a face-down machine and on it you can make all sizes and varieties of blocks from 6 inches to 6 feet.

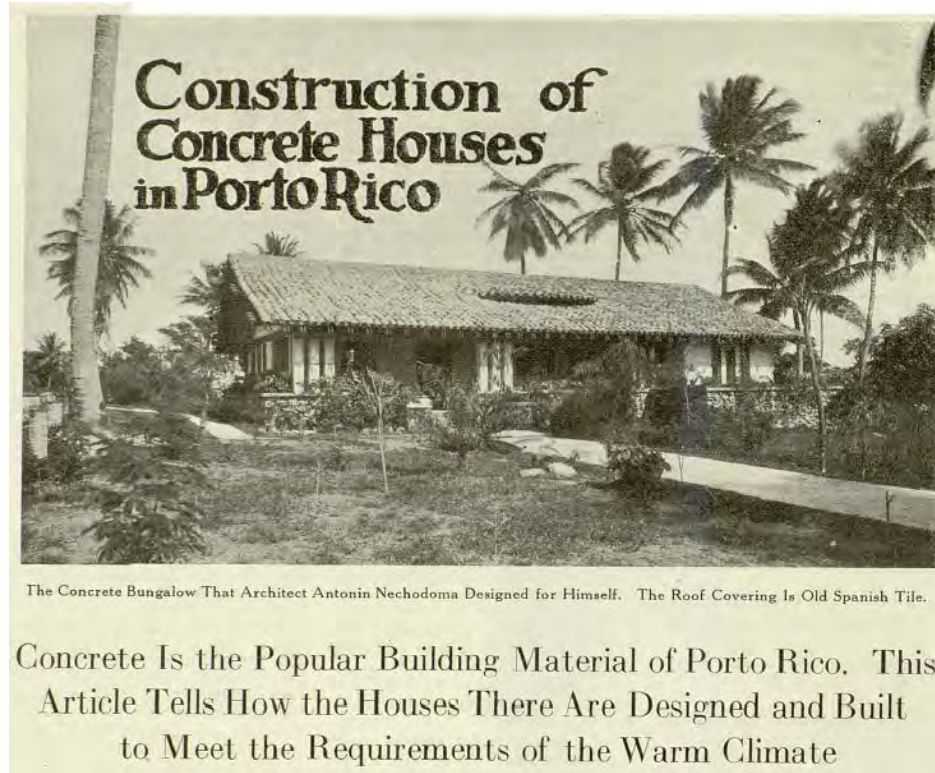
On one Hercules you can make two blocks of the same size and design or of different sizes and designs at one time—this doubles capacity.

Our beautifully illustrated 66-page catalogue is free for the asking.  
Ask for Catalogue B.

**Important Notice:** We desire to announce that we are now filling orders for the Hercules Special, a machine exactly the same as the Regular Hercules except in size. We sell this machine with a complete outfit for making blocks 8x8x6 for \$225 net. F. O. B. Rochester, or we will substitute an 8x8x8. We do more; write for further information.

**Century Cement Machine Co.**  
178 West Main Street, Rochester, N. Y.

Fig. 1.3 & 1.4— Education projects and School buildings played an essential role in disseminating American ideas and the intended Americanization project where the learning of English language played a prominent role within a Spanish-speaking population. The Insular Office of the Commissioner of Education and American firms designed these buildings using reinforced concrete and concrete blocks systems. Atlas Cement advertisement featuring the Roman Baldorioty De Castro School in Old San Juan on the local *Revista de Obras Públicas* in 1925 (Top photo). Century Cement Machine Co. promoting the Hercules Concrete Block Machine as the selected technology for School construction by the 'Porto Rico' Board of Education in 1907 (Bottom). Source: *Revista de Obras Públicas*, 1925 & *The National Builder*, Jun 1<sup>st</sup>, 1907, Vol. 44, No. 6, p. 59.



*Fig. 1.5 & 1.6*– Wealthy American investors also landed in Puerto Rico in the early 1900s, preferring the use of reinforced concrete as the 'modern and material of progress.' It was also in Condado and Miramar where residences were built in the 'cottage' or 'bungalow' style using reinforced concrete techniques and concrete blocks such as 'Compo Stone.' The house of prominent Architect Antonin Nechodoma who praised the use of reinforced concrete in the early twentieth century (top photo) & House of Mr. J.B. Diaz, today known as Casa Benítez in Miramar (bottom photo). Source: *Building Age*, August 1918, Vol. 40, No. 8, p. 396.

### 1.1.3 *The In-between period*

During the first decade of the twentieth century, new building codes and regulations favored reinforced concrete as the preferred and durable construction method in response to an unusual number of natural disasters.<sup>29</sup> Puerto Rico eventually followed these trends beginning in 1917 and after the San Fermín Earthquake of 1918 that devastated the west and southwest side of the main Island.<sup>30</sup> After this event, Portland cement and reinforced concrete were recommended and used as the preferred building materials throughout Puerto Rico: a grand majority of the standing structures constructed after the earthquake used reinforced concrete systems. The reconstruction process took months and years and included reconstruction, repairs, and additions. This era can be considered as the transition period since reinforced concrete was still an experimental technology for much of the building industry, and its performance combined with other building materials was unknown. Much of the previous local rubble and brick masonry structures such as Catholic parish churches and public buildings were demolished or repaired using reinforced concrete systems.

After the San Fermín earthquake, two official reports served as a framework for the new building codes established by the Insular Department of the Interior. Both Reports praised and noted no damage regarding reinforced concrete buildings, recommending the use of reinforced concrete widely as a seismic and fireproof resistant building technology. The *Report of the Construction Division of the U.S. Army* recommended using reinforced concrete or structural steel frame with reinforced concrete floors for all new buildings.<sup>31</sup> Moreover, a 1919 *Report of the Puerto Rico Commissioner of the Interior* also recommended construction with reinforced concrete because of the vast local availability of materials such as natural aggregates.<sup>32</sup> Simultaneously, unreinforced hollow concrete

blocks began to lose their popularity due to their poor performance during the 1918 earthquake.<sup>33</sup>

The devastation caused by Hurricanes San Felipe in 1928 and Hurricane San Ciprián in 1932 provided another trial for reinforced concrete. After San Felipe, many buildings survived the storm, but several concrete structures in both urban and countryside collapsed.<sup>34</sup> New changes to concrete construction codes included thicker walls with additional steel reinforcing.<sup>35</sup> These natural disasters in the first three decades of the twentieth century provided a trial and error framework for the development and enhancement of reinforced concrete building technologies in Puerto Rico.

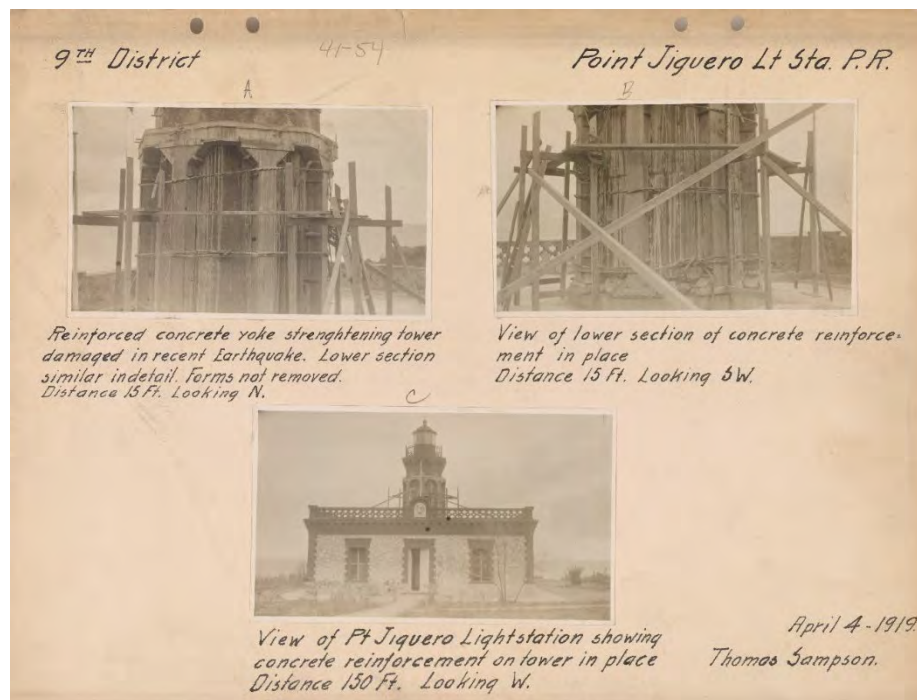


Fig. 1.7 – Original Punta Higüera/Point Jiquero Lighthouse in Rincón (West coast side of Puerto Rico) which suffered structural damages after the San Fermín Earthquake. In July 1919, the U.S. Congress approved \$24,000 for its reconstruction which used reinforced concrete systems. Major repairs on buildings damaged by the earthquake were done using reinforced concrete on rubble masonry and brick buildings. Source: U.S. National Archives. Department of Commerce, Bureau of Lighthouses Photographic Collection. 1913-7-1-1939 – 1919.

#### 1.1.4 Concrete and 'Modernity'

"...[Modernity] enabled an approach that favored techniques of lightness, synthetic materials, and standard modular parts, to facilitate manufacture and construction; this produced the effect of a loss of mass and solidity, which had been the essential characteristics of traditional architecture."<sup>36</sup>

"...more than any other material, concrete-reinforced, prestressed, cast-in-place, and precast-was widely used and became most symbolic of the architecture of the Modern Movement."<sup>37</sup>

Between 1935 and 1940, the use of imported American Portland cement for construction represented 75% of the total amount used in Puerto Rico.<sup>38</sup> Both the Great Depression and the devastation of several natural disasters such as Hurricane San Ciprián in 1932 left the Islands in a state of extreme poverty and despair. In 1934, President Franklin Delano Roosevelt, by Executive Order, created the Puerto Rico Reconstruction Administration (PRRA). As a New Deal program, along with the Plan Chardón, the PRRA sought to relieve poverty conditions, provide employment opportunities, and offered a massive infrastructure project.<sup>39</sup> This federal agency employed many local contractors, engineers, architects, and construction workers in Puerto Rico.<sup>40</sup>

Along with the extensive list of infrastructure projects, the PRRA projects focused on institutional buildings (schools, health centers, hospitals), residential development in rural and urban areas, and other works such as government-owned factories. Although the PRRA experimented using different building materials such as brick and rammed earth, many of these projects adopted reinforced concrete.<sup>41</sup>

Since 1920, with the increasing appearance of slums within the metropolitan region of San Juan, housing became one of the strategic projects of the PRRA.<sup>42</sup> The PRRA's



response to the problem resulted in public and low-cost suburban housing, both utilizing reinforced concrete, as the ideals of concrete as a 'clean and sanitary' material persisted.



*Fig. 1.8* – In the development of *El Falansterio*, the first Public Housing complex, and the Eleanor Roosevelt and Morel Campos suburban developments, the PRRA promoted hundreds of structures using reinforced concrete with simple design and flat roofs, which led to the quick production of these buildings. Photo of the Urbanización Morell Campos in Ponce under construction. Source: Biblioteca Digital Puertorriqueña, University of Puerto Rico-PRRA Collection.

The establishment of a cement factory in Puerto Rico was among the most significant achievements of the PRRA concerning the development of Portland cement and reinforced concrete in the Islands. This was a substantial shift in availability since imported Portland cement from Europe and the United States supplied the demand for the local construction industry during the first three decades of the twentieth century. As historian Guillermo Baralt discusses, the establishment of a local cement factory in Puerto Rico came in response to the rise in cement prices beginning in 1935 and the demand for the material for projects of the PRRA. However, since the late nineteenth century, there were conversations about establishing a Cement factory due to an abundance of natural calcic formations and other materials around Puerto Rico.<sup>43</sup>

The Cement plant was built in 1937 at Barrio Amelia in Guaynabo, between Cataño and Guaynabo, a zone of natural calcic formations, readily accessible to the Ports of San Juan. The Plant produced up to 1.4 million bags of Portland Cement annually. The factory was inaugurated in 1939 and was later transferred to the Puerto Rico Industrial Development Corporation (PRIDCO). Renamed as the Puerto Rico Cement Corporation in 1940, the factory doubled its production in the incoming years.



*Figs. 1.9 & 1.10* – The Cataño Cement Plant was completed in 1938 and renamed the Puerto Rico Cement Corporation (PRCC) in 1940. The plant was located ‘between the low hills and marshy bay shore of Guaynabo’. Source: National Archives Record Group 135-SAR: Prints: Photographs rejected for use in the Photographic Report to the President: “Survey of the Architecture of Completed Projects of the PWA, 1939;” Box 23: Puerto Rico file. Scanned and processed by Evan Kalish. <https://livingnewdeal.org/projects/catano-cement-plant-guaynabo-pr/>

The ambitious infrastructure projects from the PRRA, such as public and rural housing, hospitals, schools, and roads, did not thwart criticism.<sup>44</sup> In 1943, prominent American publications criticized the reality of the territory. They strongly condemned the American colonial administration that allowed Puerto Rico to become an 'American slum,' a 'poorhouse, and a disgrace of the United States.'<sup>45</sup> Considering the delicate and diplomatic dimensions of these issues, President Franklin Delano Roosevelt appointed one of his trusted men, Rexford G. Tugwell, as Governor of Puerto Rico in 1941.<sup>46</sup> Tugwell advocated for significant socio-economic structural changes in favor of controlling and developing better infrastructure for Puerto Rico alongside an agrarian reform.<sup>47</sup> Almost simultaneously, the Partido Popular Democrático / Popular Democratic Party of Puerto Rico (PPD) obtained a decisive victory in the local legislative elections of 1938 with its leader Luis Muñoz Marín at the head. The Party's reformist platform with 'Pan, Tierra y Libertad' (Bread, Land, and Liberty) as its motto sought to improve the living and health conditions of thousands of Puerto Rican farmers and workers.<sup>48</sup>

As part of the ongoing reforms, the Government of Puerto Rico created several state agencies such as the Junta de Planificación, Urbanización y Zonificación de Puerto Rico/Puerto Rico Urban Planning and Zoning Board in 1942.<sup>49</sup> The Planning Board, alongside other agencies, would provide an institutional framework to test modernist ideas, using Portland cement and reinforced concrete, in the Puerto Rican built environment. In 1943, at the same time as American journalists had denounced the living conditions of the colonial territory, the government of Puerto Rico created the Comité de Diseño de Obras Públicas/Committee on Design of Public Works (CDPW).<sup>50</sup>

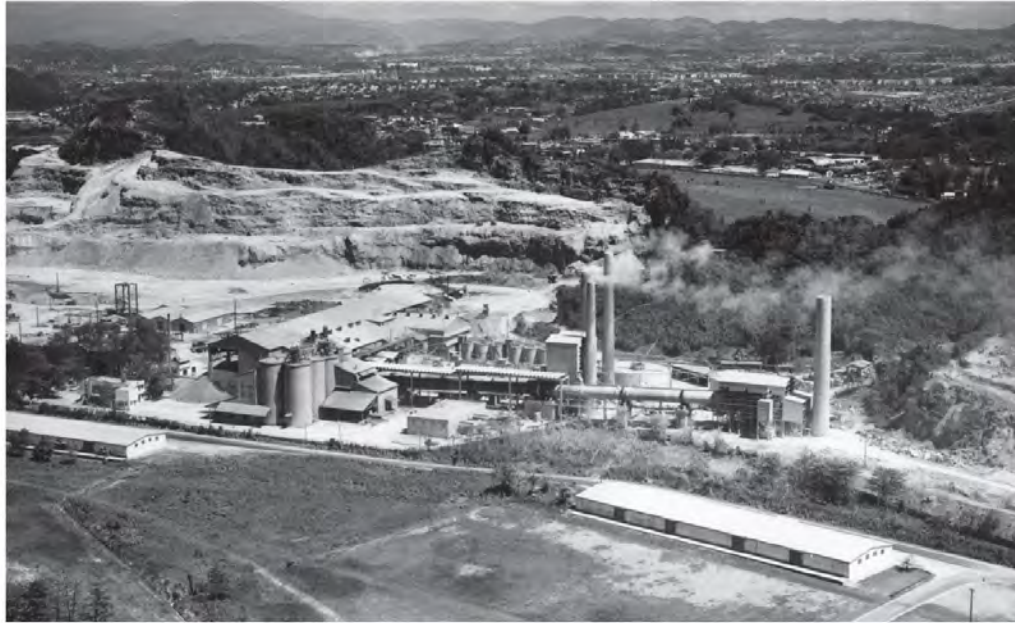
During the first half of the twentieth century, architecture in Puerto Rico, as elsewhere in the Caribbean, was based on historicized styles.<sup>51</sup> From the 1940s onward, these architectural styles were associated with the prevailing poor conditions in Puerto

Rico.<sup>52</sup> The determination of Tugwell, the PPD, and other political forces to leave behind the 'old and elitist styles' to shape a new country came to fruition with the Committee on Design of Public Works.<sup>53</sup> In this sense, the new government agencies, created in the middle of World War II, became instrumental in developing a 'modern and progressive' Puerto Rico, which included new architecture using Portland cement and reinforced concrete. As Enrique Vivoni Farage points out:

“...the government approved the creation of this Committee with the purpose of preparing during the World War II years, complete sets of plans [and drawings] for the construction of a new Puerto Rico.”<sup>54</sup>

#### 1.1.5 *World War II and the U.S. Military infrastructure projects*

During World War II, Puerto Rico, as an essential strategic military possession of the United States, saw the development of an extensive military infrastructure plan put in place by the U.S. Department of War. Because of the high demand and federal restrictions on Portland cement importations on the eve of World War II, the U.S. Department of War required more local Portland cement for the anticipated massive military infrastructure projects throughout the Islands. In 1942, Ferré Industries, with the support of the U.S. Army, inaugurated the Ponce Cement Factory, located on Ponce, on the southern coast of Puerto Rico. The two local factories guaranteed the supply of Portland Cement and the use of reinforced concrete and concrete blocks for the military projects of the ongoing War.



*Fig. 1.11* – The Ponce Cement Corporation Plant in 1949. Source: Archivo General de Puerto Rico (AGPR)/Puerto Rico General Archives, Mirabal Collection – Ponce.

In the early 1940s, federal government projects such as the 10<sup>th</sup> United States Naval District in San Juan, the Borinquen Airfield in Aguadilla, and Roosevelt Roads in Ceiba brought other architectural forms to Puerto Rico.<sup>55</sup> Later, when the global stage after World War II changed, the United States needed to 'change' its colonial relationship with Puerto Rico. During this period, America developed the 'good neighbor' foreign policy doctrine, which positioned the U.S. as a partner to Latin American countries. Puerto Rico, a U.S. territory, would be the 'bridge' and key for that policy.<sup>56</sup> The question remained on how this could be achieved as Puerto Rico still suffered deplorable socio-economic conditions.

If Puerto Rico was to be as modern and prosperous as any major western country and become the 'bridge' between Latin America and the U.S., the Islands needed to adapt its architecture, forms, and construction technologies. Beginning in 1946, the Insular Government with the Puerto Rico Development Corporation (PRIDCO) saw the

opportunity to create a tourist market for the Island.<sup>57</sup> At the same time, the Government of Puerto Rico, through PRIDCO, incentivized the use of Portland cement from the Puerto Rican Cement Factories on some of its most iconic projects, such as the Caribe Hilton.<sup>58</sup>

In 1947, the U.S. Congress passed the Elective Governor Act, and Puerto Ricans could elect their own Governor. One year later, the PPD leader Luis Muñoz Marín became the first Puerto Rican Governor democratically elected. Alongside Muñoz's victory and the PPD majority in the Insular Legislative Assembly, the party developed reforms divided into three plans, which guided the socio-economic development of the islands since the 1950s. These plans were Operación Manos a la Obra/Operation Bootstrap (for economic development), Operación Serenidad/Operation Serenity (for education and culture), and Operación Estado Libre Asociado/Operation Commonwealth.<sup>59</sup> Operation Estado Libre Asociado sought to 'transform,' in a certain way, the relationship between the U.S. and Puerto Rico.<sup>60</sup>



*Fig. 1.12 – Governor Luis Muñoz Marín visiting a Slum (c.1951) at the Condado Lagoon which was to be eliminated after his official visit. At the right rear end of the photo, the Caribe Hilton Hotel is shown, built using Puerto Rican Cement, proudly standing as the symbol of the 'new' Puerto Rico. Source: Rafael Picó, Diez Años de Planificación en Puerto Rico. Junta de Planificación de Puerto Rico, 1952, 43. Colección Puertorriqueña, UPR.*

This era was crucial for the development of concrete in Puerto Rico. In 1945, hollow concrete blocks for new construction became standardized facilitating construction and supporting the already 13 concrete block factories established on the main island since early in the decade.<sup>61</sup> Simultaneously, the utilization of Portland Cement in Latin America could also be considered the norm.<sup>62</sup> The increased demand by the military for construction materials allowed very few private construction projects. This forced contractors, engineers, architects, and construction workers to carry out military projects. The population growth of the 1940s and the 1950s led thousands of Puerto Ricans to benefit from the employment opportunities that the construction of these massive military projects provided. Poor workers learned, firsthand, the craft and skills of reinforced concrete, including Cast-in-place methods, which were eventually passed down to future generations.<sup>63</sup>

#### 1.1.6 *After the War*

At the end of World War II, along with the establishment of Puerto Rico's Constitution and Operation Bootstrap's economic miracle, a quick rise in demand for housing resulted from veterans returning to Puerto Rico. In 1947, private suburban housing developments appeared thorough the metropolitan region.<sup>64</sup> Slum elimination continued to be a priority for Puerto Rico's government as tourism-driven developments occurred throughout San Juan. After the War, an aggressive campaign for eradicating these 'unsanitary' areas of San Juan led to the construction of massive public housing projects. Along with these, the 'Urbanizaciones' -suburban and car-centered complexes- became the standard model of living for a growing middle class and the veterans returning from WWII.

As the policies adopted by the PPD led-Government brought quick, impressive results, "progress, cleanliness and happiness" became the mottos of an era when federal



and local insular governments pushed for the development of a new architecture.<sup>65</sup> World War II veterans returning from abroad expected the commodities and infrastructure promised by the Federal government. Puerto Rico saw a massive transformation in less than two decades. As Dr. Jerry Torres points out:

"...it was intended to be a "peaceful revolution" as a local response to the revolutionary Latin-American movements... [they sought] a rupture with the past (what we were) and a definition with the future (what we would be)."<sup>66</sup>



*Fig. 1.13* – Bay View in Cataño and Puerto Nuevo in San Juan became pioneering private suburban developments with the construction of hundreds of plain and unornamented housing units with flat roofs and horizontal elements in their design. Using reinforced concrete (quick, portable, easy to use, and inexpensive construction system, and also as the 'clean and sanitary' building material), these residential typologies paved the way for future modern residential units in Puerto Rico. Photo of the Urbanización Puerto Nuevo seen from the San Patricio area c.1949. Source: Héctor Ruiz, "Urbanización Puerto Nuevo-1949", *Redescubriendo a Puerto Rico* Blog, March 13th, 2013, <https://redescubriendopuertorico.blogspot.com/2013/03/urbanizacion-puerto-nuevo-1949.html>



*Fig. 1.14* – On June 27<sup>th</sup>, 1953, the Puerto Rican Government inaugurated the largest public housing complex in Puerto Rico and the Caribbean made of reinforced concrete. The Residencial Luis Lloréns Torres in San Juan was a massive urban development project in the Islands with over 140 reinforced concrete buildings three to four stories each and over 2,600 apartments, with a capacity of 10,000 to 15,000 people. Photo of the Inauguration of the housing complex in 1953. Source: Baralt, *Una de Cal y Otra de Arena*, 283 & Biblioteca Digital Puertorriqueña, University of Puerto Rico – El Mundo.

The cement factories continued helping to build the foundations of a ‘new country.’ In 1948, the local production of Portland cement rose to 4 million bags annually, and in the 1950s, both factories combined produced up to 6.8 million bags of Portland cement annually, leading to surplus exportation. However, as part of the policies of Muñoz Marín and the PPDs Operation Bootstrap, all government-owned factories eventually were sold or closed, including the Puerto Rico Cement Corporation in Cataño. After 1957, the production of Portland cement in Puerto Rico entered a period of expansion.<sup>67</sup> The Ponce Cement Corporation bought the Puerto Rico Cement Corp. and merged in 1963, creating the Puerto Rican Cement Inc.<sup>68</sup> At the time, Puerto Rico produced over 7 million barrels of Portland Cement annually.<sup>69</sup> In the 1960s, significant infrastructure projects continued, and San Juan Cement, another cement factory, opened in 1965.<sup>70</sup> The immigration of

Cuban architects, engineers, and contractors are also credited with the advancement of Portland Cement technologies after the Cuban Revolution of 1959.<sup>71</sup> The 'modern project' greatly benefited from Portland cement technologies and the use of reinforced concrete to build 'a new Puerto Rico' under the colonial order.

In 1958, a front-page article of *Time* magazine called Operation Bootstrap and Muñoz's policies a miracle. Puerto Rico, in the early 1960s became the 'Vitrina de la democracia' or the 'Showcase for democracy.' As the U.S. and Soviet relations had deteriorated, and the Red Scare emerged, these ideas became a valuable tool to show other Latin American countries the benefits of 'American democracy and their way of life.' In this sense, Puerto Rico embraced concrete and modern architecture not only as means of helping the populace with new infrastructure projects but as an ideological tool used by the U.S. to show the benefits of the 'American democracy' and Capitalism in a post-WWII scenario. Architects were active participants in the development of these projects.

**CEMENTO Y PROGRESO!**

En el pase de lista de los elementos que han hecho posible el fabuloso desarrollo y progreso de Puerto Rico, el cemento siempre ha respondido... Presente...!

El moderno Condominio Monteflores es una aportación más al desarrollo y progreso urbano de Puerto Rico.

En la construcción de este moderno edificio, diseño de la firma de arquitectos Montilla y Láttimer, está presente el cemento. El cemento de Puerto Rico ha contribuido una vez más al progreso con su aportación substancial a la realización de esta obra, un nuevo motivo de orgullo para los puertorriqueños.

**PUERTO RICAN CEMENT COMPANY, INC.**

Manufacturas de  
CEMENTO PONCE • CEMENTO PUERTO RICO • CAL FLORIDA

**¿Podría imaginarse el progreso de Puerto Rico sin cemento?**

¿Dónde estarían todos esos nuevos edificios? ¿Y las urbanizaciones, las escuelas, las carreteras? ¿Cómo sería este nuevo perfil de Puerto Rico?

El cemento le está dando forma al progreso de la isla en más de un sentido. No sólo sirve para construir, sino que crea miles de empleos, paga altos salarios y ayuda a fomentar otras industrias con las compras de materiales y servicios.

El hecho de que en Puerto Rico se produzca cemento de primera calidad a precio bajo, ha estimulado el crecimiento de la industria de la construcción. Y el cemento contribuye a fortalecer la vida cultural del país con becas y ayuda a instituciones de estudios superiores. También tuvo el cemento muchísimo que ver con la creación de nuestro primer museo de arte.

Es difícil concebir el progreso de Puerto Rico sin el cemento.

**PUERTO RICAN CEMENT CO., INC.**

Una vida mejor para los puertorriqueños.

**vamos hacia usted y con el PROGRESO**

Figs. 1.15, 1.16 & 1.17 – The ideas of ‘progress’ behind the use of Portland Cement in Puerto Rico was part of the prevailing narratives from the early 1950s through the 1960s. Announcements from the Puerto Rican Cement Company and the cement industry enforced these notions. Source: Revista Urbe, Dec 1964-Jan-Feb 1965, p. 58; Revista Urbe, Apr-May 1968, p. 18, & Revista Urbe, Oct-Nov 1967, p. 14.

### 1.1.7 *Conclusions*

The use and development of Portland cement and reinforced concrete in Puerto Rico became the norm since it was introduced by the federal government and North American contractors to create new public and private infrastructure projects. Moreover, natural disasters boosted the use of concrete as the only building material capable of resisting hurricanes and earthquakes. Additionally, the ideas behind the American project as a civilizing society merged with nineteenth-century ideas of concrete as a 'progressive material,' eventually selling it to low-income Puerto Ricans as 'civilizing, hygienic, standard and progressive' building material for the construction of new residential units throughout the Islands. These notions about the material prevailed throughout the first half of the twentieth century.

At the same time, other factors aided the advancement of a mid-century modern architecture in the Islands. First, the insular and federal government sought to leave behind prevailing historicist styles and imposed a new architectural style with massive military infrastructure projects, aided after 1942 by the projects of both the Puerto Rico Planning Board and Committee on Design of Public Works. Second, the economic boom that resulted from Operation Bootstrap and the establishment of the Estado Libre Asociado/Commonwealth in 1952. Third, the influence and arrival of foreign architects, such as Henry Klumb, also linked to the government, led to significant contributions to the built environment with projects in public and private practice.<sup>72</sup> The migration of Cuban architects and other construction professionals after the Cuban Revolution of 1959 brought extraordinary knowledge of the field to the island.<sup>73</sup> All these foreign architects knew, firsthand, how to work the plasticity of reinforced concrete for modern architecture, which eventually impacted the architectural production of the era in Puerto Rico.

Finally, the influence of foreign American and European architectural firms in developing an 'International style' of architecture encouraged leading local architects to publish their work in a variety of international journals, books, and magazines of the era. In the end, modern architecture in Puerto Rico was conceived by those in power and was quickly assimilated with hardly any opposition.

Since the great infrastructure projects of the mid-1940s, no other building material became part of the dreams and desires of Puerto Ricans as concrete. The development and use of Portland cement and concrete technologies were dramatic since the 'American project' eventually displaced previous construction technologies used locally for over 400 years. Reinforced concrete is nowadays the vernacular building material in Puerto Rico in the sense that it is 'local.' Both reinforced concrete and mid-century modernism became the lynchpin of modernity by advertising the Islands as the 'showcase of [American] democracy' in Latin America and the Caribbean.

## **1.2 The rise of the Concrete modern church**

The historical development of Catholic liturgy led to significant changes in church architecture, especially in the twentieth century. Both at the international and local levels, the development of modern church architecture responds to a series of liturgical shifts that eventually led to the celebration of the Second Vatican Council between 1962-1965. In the first half of the twentieth century, new liturgical ideals and notions paved the way for new forms, materials, and spaces in Catholic churches.

The Liturgical Revival movement has its origins in a series of attempted reforms that Pope Pius X envisioned before his death in 1914. The ideas behind this movement proposed a:

"...return to the more ancient concept of Christianity, lost during the Middle Ages, in which officiating priest and laity were intimately one within the mystical body of the Church. The liturgical effect of this concept is to bring the congregation into more active participation in the Mass."<sup>74</sup>

Liturgical Revival attempted to encourage more active participation of the congregation during masses and proposed a more intimate relationship, both spiritually and spatially. These ideas led to the suggestions and interpretations of new Catholic church design principles. The surge of the movement on church architecture occurred in Europe during the 1920s. The ideas behind returning to a different liturgy within the Catholic church highlighted its need to return to community life, service, and provide clarity and transparency. These principles would be captured in an 'honest architecture,' where functionalism played a spatially determining role, and the architect would have freedom of expression.<sup>75</sup> In this sense, Catholic church architecture would slowly embrace the prevailing ideas behind modern architecture developed in the first half of the twentieth century:

"...building problems can be solved by a return to first principles based upon the liturgy- that is, art in its relation to, and in the service of, the living liturgical community. In this sense, we can claim that the formula "form follows function" takes on a reasonable meaning."<sup>76</sup>

Functionalism allowed embracing new and modern architecture materials-including concrete. One early example of European modern church architectural trends is in the church of Notre Dame du Raincy in Le Raincy, near Paris, France, designed in 1922 by Auguste & Gustave Perret. Regardless of its traditional floor plan, this church represents one of the earliest and most significant experiments of Perret in the use of reinforced concrete.<sup>77</sup> Auguste Perret contributed widely to the acceptance of reinforced concrete as both an aesthetic and structural medium in the early days, using concrete "in the same way as the finest architectural stone" to produce a variety of surface finishes.

Most importantly, Notre Dame Le Raincy is cataloged as the earliest used on exposed reinforced concrete in architecture, which allowed Perret to establish a new idiom both in ecclesiastical and modern architecture.<sup>78</sup> The project served as an exercise that led to continued experimentations by him and other architects. Le Corbusier, as a disciple of Auguste Perret, became the pioneer of the application of exposed reinforced concrete in modern architecture.<sup>79</sup> These trends echoed throughout Europe and later the United States, particularly after the 1950s.



*Fig. 1.18*– Church of Notre Dame du Raincy in Le Raincy built between 1922 and 1923 by French Architect Auguste Perret. Photos by T.P. Bennett. Source: T.P. Bennett, *Architectural design in concrete*, Ernest Benn Ltd., 1927, <http://collectionsblog.aaschool.ac.uk/notre-dame-du-raincy-architectural-design-in-concrete/>

Earlier, in the United States, Frank Lloyd Wright's Unity Temple in Chicago (1904) opened the doors to the use of reinforced concrete both as an innovative structural technology as well as an aesthetically valid surface finish. As Susan Macdonald mentions, both Perret's and Wright's churches "exploited reinforced concrete in ways that were not realized on a larger scale until well into the second half of the [twentieth] century."<sup>80</sup>



The Benedictine Order in the United States is credited with being one of the first Catholic Orders to embrace Liturgical Revival ideas. The Abbey of St. John the Baptist in Collegeville, Minnesota, by Marcel Breuer from 1953 through the early 1960s, is perhaps the best example of the adherence of the new liturgical principles, including the use of reinforced concrete. Simultaneously, the Dominican Order in Puerto Rico would initiate the modern religious architecture movement on the Islands.<sup>81</sup>



*Fig. 1.19 & 1.20* – Frank Lloyd Wright’s Unity Temple built in 1904, photo by Henry Fuermann and Sons Photography Company, c. 1910 (left photo). The Abbey of St. John the Baptist in Collegeville, Minnesota, by Marcel Breuer in 2019 (right photo). Source: Frank Lloyd Wright Preservation Trust – Digital Image Collection <http://cdm15014.contentdm.oclc.org/cdm/singleitem/collection/p15014coll3/id/36/rec/3> & Minnevangelist, <https://minnevangelist.com/saint-johns-abbey-collegeville/>

### 1.3 Portland Cement and Concrete in Puerto Rican Church Architecture

"The fundamental difference between modern [church] architecture and the historic styles lies in the nature of the material."<sup>82</sup>

As discussed earlier, materials choices and materiality in architecture often respond to a social-political-economic-cultural context. Materials and tectonics play a crucial role in the spatiality and aesthetics of architecture. In Puerto Rico, the use of Portland cement and concrete technologies in religious architecture responds to its early twentieth-century context. Specifically, when after the Spanish-American War of 1898, protestant missionaries arrived in Puerto Rico.

Protestant missionaries settled throughout the islands, looking to provide relief to distressed communities, bringing the knowledge of the 'kingdom of God' to an almost entire Catholic population, supporting at the same time the 'Americanization' project. The legacy of wood and rubble-masonry catholic churches was left behind by Protestant churches designed using concrete block and reinforced concrete. The use of early building technologies such as concrete block, which was portable, efficient, and economic, would prove useful for the development of new buildings that would support the evangelization project. Following these intents, those first buildings -primarily churches, would be constructed on visible sites (preferably right across or near the existing Catholic Church of each town) of rural and urban towns around Puerto Rico.<sup>83</sup>



Fig. 1.21 – In 1899, the Protestant Missionaries divided the main island of Puerto Rico into 8 to 9 districts in which they would settle and build churches, schools and hospitals to expand their ministries to a mostly catholic population. Source: Samuel Silva Gotay, *Protestantismo y Política En Puerto Rico- 1898-1930*, p. 113.

Along with the buildings of the Polythetic Institute in San Germán (today the Interamerican University of Puerto Rico), Czech architect Antonín Nechodoma, one of the earliest concrete enthusiasts in the Spanish Caribbean, would design a series of important churches in San Juan and Ponce. The Presbyterian Church, which established the Polytechnic Institute of Porto Rico, used rock-faced hollow cement-block manufactured on-site for their buildings.<sup>84</sup> Other early evangelical churches are the First United Methodist Church in Ponce (1907), the Methodist Church in Miramar -today Nuestra Señora de Lourdes Chapel (1908), the McCabe Memorial Church in Ponce (1908), and the Collins Memorial Church in Aibonito (1908), amongst others.

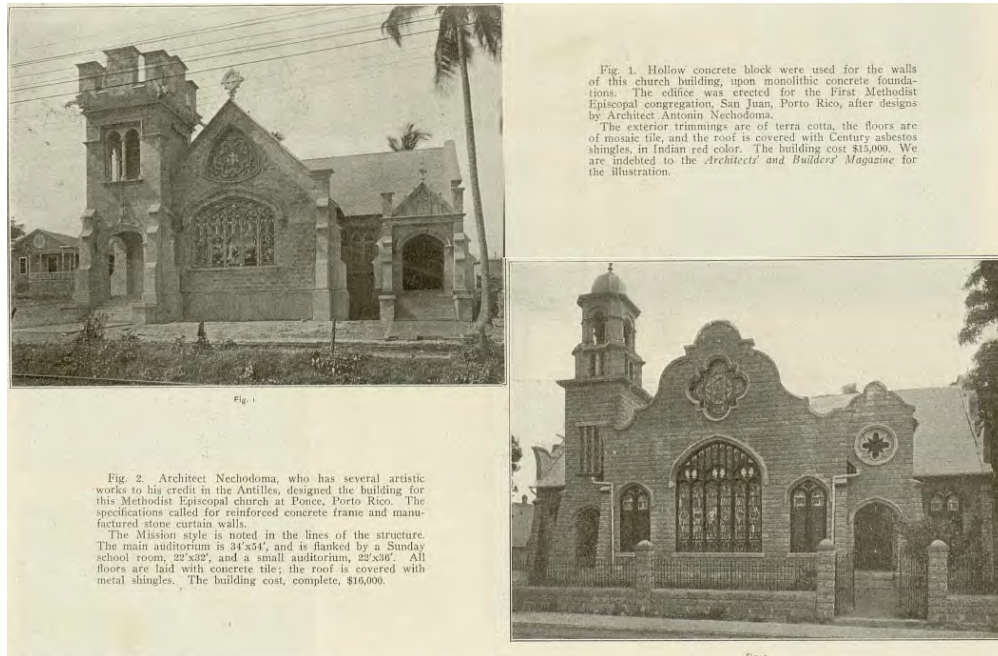


Fig. 1. Hollow concrete block were used for the walls of this church building, upon monolithic concrete foundations. The edifice was erected for the First Methodist Episcopal congregation, San Juan, Porto Rico, after designs by Architect Antonin Nechodoma. The exterior trimmings are of terra cotta, the floors are of mosaic tile, and the roof is covered with Century asbestos shingles, in Indian red color. The building cost \$15,000. We are indebted to the *Architects' and Builders' Magazine* for the illustration.

Fig. 2. Architect Nechodoma, who has several artistic works to his credit in the Antilles, designed the building for this Methodist Episcopal church at Ponce, Porto Rico. The specifications called for reinforced concrete frame and manufactured stone curtain walls. The Mission style is noted in the lines of the structure. The main auditorium is 34'x54', and is flanked by a Sunday school room, 22'x32', and a small auditorium, 22'x36'. All floors are laid with concrete tile; the roof is covered with metal shingles. The building cost, complete, \$16,000.

Fig. 1.22 – The Methodist Church in Miramar, San Juan built in 1908 & the First United Methodist Church in Ponce built in 1907. Both churches used early Concrete Hollow blocks. Source: *Concrete*, Vol. 9, No. 7, Jul 1st 1909, p. 35.



(1) TEMPLO DE LOS DISCÍPULOS DE CRISTO.—DISCIPLES OF CHRIST CHURCH, COROZAL. (2) TEMPLO PRESBITERIANO.—PRESBYTERIAN CHURCH, MAYAGÜEZ. (3) TEMPLO DE LA ALIANZA CRISTIANA.—CHRISTIAN ALLIANCE CHURCH, BARCELONETA. (4) TEMPLO CONGREGACIONAL.—CONGREGATIONAL CHURCH, FAJARDO. (5) TEMPLO DE LOS HERMANOS UNIDOS EN CRISTO.—UNITED BRETHREN CHURCH, YAU'CO. (6) TEMPLO LUTERANO.—LUTHERAN CHURCH, SAN JUAN.

Fig. 1.23 – Protestant churches built around the Islands up to 1921. Source: E. Fernandez García, Ed., *El Libro de Puerto Rico/The Book of Porto Rico*, San Juan, PR: El Libro azul publishing Co., 1923, p. 134.

Around that same time, the Catholic church, devastated by the political changes of the new American regime, began to embrace concrete construction methods. Antonio M. Martínez y José Lázaro García designed the St. Augustine Parochial Church built in 1914 of a neo-romantic style, using reinforced concrete and brick masonry. This church became one of the first Catholic churches in Puerto Rico to use these technologies, situated in the expanding neighborhood of Puerta de Tierra- between the Old San Juan and the exclusive Miramar suburbs. Concrete technologies would not only serve as the Protestant enterprise, but also the Catholic one.



*Fig. 1.24* – Iglesia de San Agustín / St. Augustine Parochial Church in Puerta de Tierra, San Juan c.1930s.  
Source: Rodríguez Archives – Archivo Fotográfico Digital de Puerto Rico.

Despite the continued use of traditional rubble-masonry and wood in church architecture during the first decades of the twentieth century, the use of cement and reinforced concrete became imperative after the San Fermín Earthquake of 1918 and

subsequent Hurricanes. These events left a considerable amount of Parochial churches with severe damage and in ruins. Natural disasters permitted (and incentivized) the use of concrete systems-such as reinforced concrete, to be used on repairs of traditional parish churches or their total replacements. During the 1930s and 1940s, historicist styles, such as the Spanish Revival style, led to new church construction efforts. Churches such as Nuestra Señora del Pilar in Río Piedras (1933) by Francisco Porrata Doria and the Sagrado Corazón de Jesús (1928-1940) by Joseph O'Kelly in Santurce are among the best representative examples of reinforced concrete churches of the period.

After World War II, the economic boom and the development of new reinforced concrete technology helped in the construction (and demolition) of parish churches and chapels throughout Puerto Rico. As the aesthetic trends and principles of modernism gained popularity and the population grew in urban areas, traditional neoclassical churches from the earlier centuries became outdated. As architect Thomas Marvel Jovannoni mentions, Parish priests around the Islands sought expansions, renovations, and even demolitions of their parochial churches.<sup>85</sup> As they conceived traditional rubble-masonry and wood churches -uncomfortable, with limited space, and which had been severely damaged by natural disasters-, reinforced concrete aided the communal desires to obtain durable, 'cleaner,' bigger and open interior spaces with less structural vertical supports for their worship needs.

As a material known for its strength, plasticity, and versatility, reinforced concrete would serve to develop new reinforced technologies such as thin shells, paraboloid forms, the production of shell vaulting, and application to large slabs.<sup>86</sup> Precast, cast-in-place, concrete masonry units, shotcrete, among other technologies, permitted architects from the era to explore and experiment with the material, providing a framework for sculptural profile experimentations in buildings, including churches.

The Dominican Friars, the first Catholic Order to settle and establish a Catholic Convent and chapel in 1521 in Puerto Rico, would pioneer the modern church movement beginning in the late 1940s.<sup>87</sup> The Sanctuary of the Blessed Martín de Porres (1946-1952) by architect Heinrich 'Henry' Klumb represents the earliest example of this contextual phenomenon: the erection of a modern design church on the newly developed suburbs using reinforced concrete. The Liturgical Revival ideas embraced by the Dutch Dominican Order and their collaboration with Klumb proved to be a successful project since San Martín de Porres would become the reference for modern church architecture in Puerto Rico and Latin America. Klumb's churches for the Dominican Order such as Santa Rosa de Lima (1946-1947), San Judas Tadeo Chapel (1953-1961), Nuestra Señora del Carmen (1963), the Dominican Seminary (1963) and the San Ignacio Church (1964-1967) for the Jesuit Order in Río Piedras, not only shows the architect's dedication towards modern religious spaces but also reflects an expansion period of the Catholic church in Puerto Rico between the late 1950s and early 1960s.<sup>88</sup>



*Fig. 1.25 – The Santa Rosa de Lima Church in Bayamón (1946-1947). Source: AACUPR – Klumb Collection.*



*Fig. 1.26* – Sanctuary of the Blessed Martín de Porres (1946-1952) in Cataño. Source: AACUPR – Klumb Collection.

*Fig. 1.27* – The San Judas Tadeo Sanctuary in Cataño (1953-1961). Photo by Héctor Balvanera, 2018.



*Fig. 1.28* – The Dominican Seminary in Bayamón (1963). Source: AACUPR – Klumb Collection.





*Fig. 1.29* – The Del Carmen Church in Cataño (1962). Source: AACUPR – Klumb Collection.

*Fig. 1.30* – The San Ignacio Church for the Franciscan Order in Río Piedras (1963-1967). Photo by Héctor Balvanera, 2018.



Other architects embraced the technical innovations that only reinforced concrete would provide. Significant examples are architect Efraín Pérez Chanis' Santa Catalina de Siena (1963-1962) for the Dominican Fathers; Amaral & Morales' Parroquia Santos Ángeles Custodios (1964-1967) in Yabucoa; architect Angel Avilés with Nuestra Señora Reina de los Angeles (1960-1962) in Carolina, and Francisco Porrata Doria with María Auxiliadora Church (1959-1962).<sup>89</sup>



*Fig. 1.31 – The Santa Catalina de Siena Church (1962-1963) in Bayamón by architect Efraín Pérez Chanis. Source: José Fernández, *Architecture in Puerto Rico*, 1965, p. 166.*

*Fig. 1.32– The Santos Ángeles Custodios Church (1964-1968) in Yabucoa by Amaral y Morales architects. Source: Marvel & Moreno, *Architecture of Parish Churches in Puerto Rico*, 2<sup>nd</sup> Ed., 1994, p. 188.*



*Fig. 1.33 – The Santa María Reina Church (1955-1957) in Ponce by Méndez, Brunner, Badillo & Asociados. Source: Colourpicture Publishers Inc.*

## Endnotes

---

<sup>1</sup>The Greater Antilles in the Caribbean are Cuba, the Dominican Republic, Puerto Rico and Jamaica. The first three constitute the Spanish Caribbean.

<sup>2</sup>The publication of the first ASTM standard for gray Portland cement, the development of the rotary kiln in 1902 by Thomas Edison, along the increase on Portland cement plants from 50 plants in 1900 to 111 plants 1910 shows how the U.S. industry was growing in the early 20<sup>th</sup> Century. See Portland Cement Association, *Cement and Concrete, Reference Book 1956-1957* (Chicago, IL: Portland Cement Association, 1957), 11-12. Also, related to the ideas of progress behind Portland cement, a pamphlet published by the Edison Portland Cement Co. showcase these ideas stating: “To England we yield the palm for discovering the secret of cement making; and to Ancient Rome, for structural grandeur. But credit for the latest and most engrossing chapter in the Romance of Cement belongs by good right to America. Prophecy the future of industry and you will unfold the future of cement, for day by day cement is becoming more important—actually indispensable—in the progress of this nation. It is the means to ends of which only the great modern engineer, architect, and builder may dare dream. But it is more—it is the end in itself, for in its rugged durability, it is as permanent as anything we know. Every day will reveal new uses for Portland cement; every generation will leave its mark—in cement; every new generation will scan the history and add its own chapter; —that is the Eternal Romance of Cement”. See Edison Portland Cement Co., *The Romance of Cement* (Boston: Edison Portland Cement Co., c.1926), 18. Lastly, the definitions set by the American Concrete Institute for Portland cement are used in this thesis. The American Concrete Institute in ACI CT-18, defines Portland Cement as “a hydraulic cement produced by pulverizing portland-cement clinker and usually with addition of calcium sulfate to control setting.” ACI CT 18- Concrete Terminology, (Farmington Hills, MI: American Concrete Institute, 2018).

<sup>3</sup>Diana Jean Sandoval Martínez, “Concrete Colonialism: Architecture, Infrastructure, Urbanism and the American Colonization of the Philippines”, (Ph.D. Diss., Columbia University, 2017), 13, <https://academiccommons.columbia.edu/doi/10.7916/D88P6BXX>.

<sup>4</sup> In reference to the scientific concepts of human ages (stone, bronze, iron ages) that the positivist historians framed history as ‘lineal’ during the 19<sup>th</sup> Century. For a further discussion see Sandoval Martínez, “Concrete Colonialism,” 132-137. For U.S. statistics of the Concrete Industry see Portland Cement Association, *Cement and Concrete, Reference... 12-13*.

<sup>5</sup>Albert Christ-Janer and Mary Mix Foley mentions how Portland cement originally intended to reproduce traditional materials such as stone. See Albert Christ-Janer and Mary Mix Foley, eds., *Modern Church Architecture: A guide to the form and spirit of 20<sup>th</sup> century religious buildings* (New York: McGraw Hill Book Co., 1962), 4.

<sup>6</sup> In her dissertation, Sandoval Martínez discuss how Portland cement and Concrete were quickly adopted as part of the assimilation process in the Philippines. See Sandoval Martínez, “Concrete Colonialism,”.

<sup>7</sup> The definitions for concrete and reinforced concrete by Harris and ACI are used in this thesis. Cyril M. Harris defines Concrete as a “composite material consisting of a binding medium, aggregates and water.” See Cyril M. Harris, ed., *Dictionary of Architecture and Construction* (New York: McGraw 1975). Also, the American Concrete Institute in ACI CT-18, defines Reinforced concrete as a “structural concrete reinforced with no less than the minimum amount of prestressing steel or nonprestressed reinforcement as specified in the applicable building code.”

<sup>8</sup> Sandoval Martínez, “Concrete Colonialism,”15.

<sup>9</sup>Hydraulic cement tiles were also marketed as ‘easy to clean and sanitary’ by the Atlas Portland Cement Company in Puerto Rico. See Beatriz del Cueto, “Concrete Block and Hydraulic Cement Floor Tile in the Tropics: adverts, history, conservation”. (New York, NY: James Marston Fitch Charitable Foundation, June 2015), 48.

<sup>10</sup> Ibid.

<sup>11</sup> Peter Thole “Concrete is Art: The design potential of concrete” in Wessel de Jonge & Arjan Doolaar, eds. *The Fair Face of Concrete: Conservation and Repair of Exposed Concrete: Proceedings International DOCOMOMO Seminar*. (Eindhoven, Netherlands: Eindhoven University of Technology Printshop, 1998), 13.

<sup>12</sup>In 1899 nearly 10 million bbl. (barrels) of natural cement were being produced annually in the United States compared to 3 million bbl. in 1895. See Portland Cement Association, *Cement and Concrete*, 9-10.

<sup>13</sup> Investigations led by architect Beatriz Del Cueto and historian Dr. Guillermo A. Baralt represent the only sources found related to the development of Portland Cement and Concrete in Puerto Rico from the Construction history standpoint. Raúl Cartagena in his master thesis (2019), identifies three other investigations related to the development of Portland Cement on the Islands from a political and economic standpoint. These master theses

---

from the UPR School of Public Administration are: *Los grupos de presión: El caso de la industria del cemento en Puerto Rico* by Luis R. Crespo Bello (1972); *La Crisis de la Industria del Cemento: Un Acercamiento Teórico* by Javier Galarza (1982), and *Las preferencias de las compras del Gobierno del ELA ante el tratado de Area de Libre Comercio de las Américas (ALCA)* (2006). See Raúl Cartagena, "El Control de los precios del saco de cemento en Puerto Rico (1939-1984)" (master's thesis, University of Puerto Rico-Rio Piedras Campus, Dept. of History, 2019).

<sup>14</sup>A hydraulic mortar is a composite or binding material that sets and hardens by chemical reaction with water and is capable of doing so underwater. For example, the American Concrete Institute in ACI CT-18 defines hydraulic cements as a "binding material that sets under water", referring to Portland cement and slag cements.

<sup>15</sup> Ibid.

<sup>16</sup> Natural cements were widely used in the US and Europe and were being exported, especially from Spain and Belgium to Puerto Rico. Ibid.

<sup>17</sup>A great wave of mostly European immigrants moved to the Islands: those that saw the islands as a Spanish safe haven in the Caribbean, and were avoiding Latin American revolutions, and those interested in the economic incentives of the Real Cédula de Gracias which was established in August 1815. On this Dietz, mentions that "...it was created to promote population growth by stimulating migration ... Around six acres of land was ceded to all free white immigrants and another three additional acres by each slave. Free black immigrants would receive the same number as slaves. Immigrants attracted -from Spain, France, other parts of Europe, the West Indies, and the United States - brought not only slaves and other means of production. They also came full of ideas, experience, skills, and the insistence on production and profits that was characteristic of the capitalist revolutions that clothed Europe and North America. Thus, by infusing a new ideology, the Cédula de Gracias contributed to an expansion of the economy beyond the pure number of immigrants who took advantage of land concessions." James L Dietz, *Historia Económica de Puerto Rico*. (Río Piedras, PR: Ediciones Huracán, 1989), 38-39.

<sup>18</sup> del Cueto, "The Development Cement and Concrete," 46.

<sup>19</sup>There were two reasons for this phenomenon; first, Portland Cement was less expensive to manufacture than lime and easy to ship. Second, as an experimental material, the use of Portland cement for concrete was limited due to its weak properties in tension, so its uses in massive walls, foundations, and piers where reinforced concrete (pre-cast or poured into a mass and reinforced with steel) successfully worked on compressive strength. Also, Historian Guillermo Baralt states that Cement importations to Puerto Rico started in the 1870s and was known as "piedra plástica"/artificial Stone. It was used as a first-class construction material in diverse projects. These uses included mortars and renders. See Baralt, *Una de Cal y Otra de Arena*, 209-210. Also, see Luis Pumarada O'Neill, "Historic Bridges of Puerto Rico, c. 1840-1950", National Register of Historic Places Inventory/Nomination Form (San Germán, PR: Arqueología Industrial Caribeña, June 13th, 1995).

<sup>20</sup> Baralt, *Una de Cal y Otra de Arena*, 38.

<sup>21</sup> del Cueto, "The Development of Hydraulic mortars, Cement and Concrete," 46.

<sup>22</sup>The U.S. Government increased the use of Portland Cement for the construction of fortifications as result of the War, which boosted the industry. See Edison Portland Cement Co., *The Romance*, 16

<sup>23</sup> Education projects and School buildings played an essential role in disseminating American ideas and the intended Americanization project where the learning of English language played a prominent role within a Spanish-speaking population. The Insular Office of the Commissioner of Education and American firms designed these buildings using reinforced concrete and concrete blocks systems. For some schools, the Century Cement Machine Company imported the 'Hercules Cement Stone Machine' from Rochester, New York. The federal government recommended locating "an American school at every valley and every hill... with the building facing an important street." The number of new schools already built rose from 259 in 1915 to 465 in 1928, the majority built using concrete technologies such as unreinforced concrete hollow blocks and reinforced concrete. Architect Jorge Rigau highlights the role of American Firms on designing these school buildings since the Education Commissioner at the time Edwin G. Dexter, granted a contract to the Rhode Island firm Clark, Homer & Howe, for the designing 14 new public schools. Clark, Homer & Howe also served in the Technical Committee evaluating the designs for the construction of a new Capitol building in San Juan. Other American firms included Van Alen Harris which is credited for the Luis Muñoz Rivera School in Carolina (1909) and Albert B. McCulloch was construction inspector for Escuela McKinley in Ponce (1908), Haussander and Perkins of Chicago, Snyder of New York, Cooper of Boston and, especially, William B. Ittner of St. Louis. On the other hand, Beatriz del Cueto mentions that these Schools were initially designed by architects from the Office of the Commissioner of Education. She also mentions that as early as 1906 the abandonment of wood for the use of

---

cement blocks became a general policy of the Agency. Also, Rigau adds that “*The 1899 Report to the Secretary of War By early 1899, John Eaton, a former Federal Commissioner of Education, had been entrusted to handle all educational matters regarding Puerto Rico. He, in turn, advised Governor Guy V. Henry about the need to build schools. The 1899 Report to the Secretary of War recommended locating “an American school at every valley and every hill...” “with the building facing an important street,” making its presence hierarchically comparable to that of church and city hall in traditional towns.*” See Jorge Rigau, “Early XXth Century Schools in Puerto Rico” National Register of Historic Places Multiple Property Documentation Form (San Juan, PR: Jorge Rigau Architectos, August 2<sup>nd</sup>, 2012), 10; and del Cueto “Concrete Block and Hydraulic Cement,” 95-96.

<sup>24</sup> In addition, the appropriation by the U.S. Congress of \$2 million and authorizes Municipal governments to issue bond holdings for the construction programs.

<sup>25</sup>The establishment of free commerce between the colonial possession of ‘Porto Rico’ and the United States particularly led to the construction of new infrastructure for ports and docks. The Ports of San Juan would now receive vessels with products from principal cities of the U.S. All these projects developed by the U.S. Department of War were designed using concrete as the primary construction material. As an example, in 1913 the San Juan Ports Board hired the New York based construction firm PJ Calin Construction Co. for the construction of a permanent concrete quay. Additionally, one of the cement brands imported to Puerto Rico over this period were Lehigh from Pennsylvania, Atlas, Columbia, Vulcanite, White Hall, Dragon, Alsen, Berkshire White Cement and Teutonia from Germany. See Baralt, *Una de Cal y Otra de Arena*, 104-111.

<sup>26</sup> Pumarada O’Neill, “Historic Bridges,” 13.

<sup>27</sup>Baralt mentions that after the devastation of Hurricane San Ciriaco in 1899, American contractors arrived at the Islands to participate in bids for new construction or reconstruction of public works. These firms arrived from New York, Missouri, Florida, Massachusetts, among other states; and quickly positioned themselves above local firms for the intended projects. Some of these firms were: Hamilton R. Gamble, Keeper & Thacher, The Central Contracting Co., W.H. Kendrick, Keeper & Thacher, Wright & Lindey; Indiana Construction Co., The Degnon Mclean Construction, Jno. B. Carter, David C. Howell, Edward J. Kingston & The Delaware Granite & Mining Co. Tensions within the mostly European educated local architect-engineers will eventually rise. Dr. Enrique Vivoni provides an important analysis of this situation. Ibid., 94-101 & Enrique Vivoni Farage, “Lo francés en nuestra arquitectura: legitimidad y dignidad profesional en Puerto Rico (1900-1918)” in *Ilusión de Francia: Arquitectura y afrancesamiento en Puerto Rico*, ed. Enrique Vivoni Farage and Silvia Alvarez Curbelo. (San Juan, PR: AACUPR, 1997).

<sup>28</sup>Wealthy American investors financed some major projects at the time. An example of one of these projects is the reinforced concrete Dos Hermanos Bridge commissioned by the prominent Behn Brothers. The bridge connected Old San Juan-Puerta de Tierra to the new exclusive growing suburb of Condado. It was also in Condado where residences were built in the ‘cottage’ or ‘bungalow’ style using reinforced concrete techniques and concrete blocks such as ‘Compo Stone.’<sup>28</sup> It was also in this neighborhood, where the first luxury hotel for Puerto Rico in 1919, designed by the American firm Warren, Whitney; Wetmore, Charles; The Condado Vanderbilt- built using reinforced concrete. In Condado, in contrast to the rest of the Islands, prominent families could enjoy the essential services of a modern American life: good roads, sewer, and drainage, as well as quality services such as powered electricity, potable water, and early telephone communications. See Baralt, *Una de Cal y Otra de Arena*, 120.

<sup>29</sup>Sandoval discusses how natural disasters as the San Francisco Earthquake and Fire of 1906, the Earthquake of Kingston, Jamaica in 1907, and Messina, Italy in 1908 boosted the use and discourse globally on the use of Portland cement and Concrete in the built environment which impacted the Philippines, a U.S. Territory at the time. Much of these prevailing ideas were also applied to Puerto Rico. See Sandoval Martínez, “Concrete Colonialism,” 140.

<sup>30</sup> Since 1917, following these worldwide trends, the Insular Commissioner of the Interior Manuel V. Domenech established new building codes for Puerta de Tierra. These codes establish that all new construction must be of concrete or brick masonry with roof covers resistant to fires. Baralt, *Una de Cal y Otra de Arena*, 116.

<sup>31</sup>That report also recommended that Walls should be cast monolithically with floor construction and thoroughly anchored to the same.

<sup>32</sup>The two discussed reports are Harry Fielding Reid, Stephen Taber, *The Porto Rico Earthquake of 1918, with Descriptions of Earlier Earthquakes* (1919), & George B. Walbridge, Lt. Col. Quartermaster Corps. 1919. *Report by the Construction Division of the Army on Damage done in Porto Rico, 1918 Caused by Earthquake* (Washington D.C.: Construction Division of the Army, 1919). The contents of both reports are discussed and analyzed in

---

Mathew A. Morales Vega “Terremoto y Maremoto de 1918: Una mirada a la respuesta gubernamental ante la catástrofe” (unpublished manuscript, University of Puerto Rico, 2018).

<sup>33</sup> Beatriz Del Cueto discussed different reasons on why this happened. First the irregularity of on-site manufacturing and the use of defective materials such as the use of river sand. Also, she mentions that hollow units were not usually reinforced making them an easy target for hurricane winds and the tremors. See Del Cueto “Concrete Block Tile,” 95.

<sup>34</sup> The authorities concluded that the lack of concrete roofs, irregularities in the mix composition and the thickness of walls were responsible for their failure.

<sup>35</sup> Baralt, *Una de Cal y Otra de Arena*, 170-173.

<sup>36</sup> Jerry Torres-Santiago, “La Inversión de los umbrales del Edén: imágenes, arquitectura y contexto en el desarrollo hotelero de San Juan/The Invention of the Gates of Paradise: Images, Architecture, and Context in the Development of Hotels in San Juan” in *San Juan siempre nuevo: Arquitectura y modernización en el siglo XX/Ever New San Juan: Architecture and modernization in the Twentieth Century*, Enrique Vivoni Farage, ed., (San Juan, PR: Editorial UPR, 2000), 144.

<sup>37</sup> Kyle Normandin, “Physical Conservation Challenges Facing Modern Architecture,” *Experts Meeting: A Colloquium to Advance the Practice of Conserving Modern Heritage*, Kyle Normandin and Susan Macdonald, eds. Getty Conservation Institute (March 6-7, 2013): 44.

<sup>38</sup> Baralt, *Una de Cal y Otra de Arena*, 212.

<sup>39</sup> Dietz mentions that the Plan Chardón/Chardón Plan “... [was developed] from the premise that the economic reconstruction [of Puerto Rico] was possible without any fundamental political or institutional change in the existing colonial framework... [since it] proposed a reorientation of the economy through the development of appropriate industries, the relocation of small farmers to better and more productive lands, the purchase of at least one sugar mill to be operated by the government, and the increase in emigration. The goals of the Plan were to reduce unemployment; end the monopoly on land, especially absentee corporations; reduce the flee of profits, interest, and dividends to the United States; and diversify the productive structure of the economy.” The Plan, developed in early 1934, was named after Carlos Chardón, Chancellor of the University of Puerto Rico at the time, who led the efforts. Dietz, *Historia Económica*, 168.

<sup>40</sup> Historians have pointed that the visit of First Lady Eleanor Roosevelt to Puerto Rico in 1934 was a turning point for this poverty trend. The impact of her visit was part of ongoing efforts in Washington, D.C. by the Roosevelt Administration which promoted better living conditions on the Islands. In 1933, the U.S. Congress created the Puerto Rico Emergency Relief Administration (PRERA), and one year later created the Puerto Rico Reconstruction Administration (PRRA), two new federal agencies which were part of its New Deal policies. Dr. Luz Marie Rodríguez cites First Lady Eleanor Roosevelt’s impression in her 1934 visit from her memories *This I Remember* (1949): “[T]he conditions in rural houses were unsanitary enough, but in the towns, they were even more shocking [...]. Most of the houses consisted of two rooms... There were no screens and, of course no plumbing or other modern conveniences in these old brick buildings [...]. The real slums were worse [...] in the capital city. Huts made of bits of tin and scrap iron and wood picked up after the last hurricane were built out over water. We walked on duck boards placed precariously over the piling, and water came up under every house. There was also a slum which hung precariously to the side of a cliff [...]. Again, there was no sanitation.” Luz Marie Rodríguez, “¡Atajar el arrabal! Arquitectura y Cambio Social en la Vivienda Pública en San Juan/Suppressing the Slum! Architecture and Social Change in San Juan’s Public Housing”, *San Juan Siempre Nuevo: Arquitectura y modernización en el siglo XX/Ever New San Juan: Architecture and modernization in the Twentieth Century*, ed. Enrique Vivoni Farage (San Juan, PR: Editorial UPR, 2000), 76. Also, see Silvia Alvarez Curbelo, “El diseño del progreso: Henry Klumb y la modernización de Puerto Rico (1944-1948)/The Design for Progress: Henry Klumb and the Modernization of Puerto Rico (1944-1948)” in *Klumb: Una arquitectura de impronta social/An Architecture of Social Concern*, ed. Enrique Vivoni Farage (San Juan: Editorial UPR, 2007), 258.

<sup>41</sup> The PRAA provided for the construction of hydroelectric plans, ‘sanitary’ housing development, asylums and homes for sick children, public schools (including rural and industrial schools), hospitals and medical facilities, drainage and sewer systems, community centers, ports, factories, buildings for the University of Puerto Rico and other types of public works. Baralt, *Una de Cal y Otra de Arena*, 194-207

<sup>42</sup> The migration of poor people from the countryside to the dense urban areas in San Juan, Santurce and Carolina, looking for employment opportunities became an issue of concern. Thousands of people were living in ‘unsanitary’ conditions without proper access to drainage and sewers, food, and essential services. Alongside *El Falansterio* and the Eleanor Roosevelt and Morel Campos suburban developments, the PRRA constructed over

---

8,500 reinforced concrete and brick masonry houses in rural areas. The use of excellent quality concrete symbolized 'cleanliness, order, and progress.' Ibid.

<sup>43</sup> Baralt argues that the need of cheap Portland cement for the PRAA infrastructure projects paved the way for the new factory. Also, he mentions that since the late nineteenth century, Tulio Larrínaga, Chief Engineer of Public Works Office (and the 2<sup>nd</sup> PR Resident Commissioner in U.S. Congress); proposed the establishment of a cement factory, like that in Cuba's. The proposal was studied in 1913 and reconsidered during WWI. Since the 1920s Geologists looked for good lime sulfate and silica sand throughout the Islands. At the end of 1918 Engineers agreed on the suitability and quality of calcic rocks in Puerto Rico. At the end, costs prevented the construction of a Cement factory in the early 20th Century. Baralt, *Una de Cal y Otra de Arena*, 210.

<sup>44</sup> Puerto Rico was considered for inclusion in the New Deal projects during the Second Phase of New Deal Policies of 1935. Historians in Puerto Rico argue that the federal government's efforts through the Puerto Rico Reconstruction Administration (PRRA) fell short to relieve the conditions in which the majority of Puerto Ricans were living. See Rodríguez, "¡Atajar el arrabal!," 90.

<sup>45</sup> S. Burton Heath a Journalist from Harper's Magazine stated "Puerto Rico is the poorhouse of the United States" Also, in *Life magazine* in the March 8<sup>th</sup>, 1943 issue a photographic article in which compared Puerto Rico as a 'septic tank' and a disgrace to the United States. S. Burton Heath, "Our American Slum, Puerto Rico," Harper's Magazine, January 1943, 54-63, quoted from Luz Marie Rodríguez, *¡Vuelo al Porvenir! Henry Klumb y Toro Ferrer: Proyecto moderno y arquitectura como vitrina de la democracia [Puerto Rico, 1944-1958]*, Ph.D. diss., Universidad Politécnica de Cataluña, 2008, 204. Also see, Álvarez Curbelo, "El diseño del progreso," 267.

<sup>46</sup> Rexford G. Tugwell was an American economist, planner, and Professor at Columbia University. Before coming to Puerto Rico in 1941, Tugwell led the New York City Planning Commission, was a member of President Roosevelt's brain trust, and served as Undersecretary of Agriculture. Jose Fernández Vázquez, "Henry Klumb: Tropical Probes", *The Modernism Magazine* 9, no. 2 (2006): 70.

<sup>47</sup> Governor Tugwell's ideas aligned with FDR's administration and were even considered radical during their time. He believed that the government should guarantee a 'balance' in the economic and social order to all sectors of society. For a complete memoir of Puerto Rico by Tugwell see Rexford Guy Tugwell, *The Stricken Land: The Story of Puerto Rico* (New York: Doubleday & Company, 1947).

<sup>48</sup> These set of policies would include a full agrarian reform, public ownership of utilities, and a strong planning board, among other initiatives.

<sup>49</sup> In 1942, Tugwell proposed that the Insular Legislature create the Junta de Planificación, Urbanización y Zonificación de Puerto Rico/Puerto Rico Urban Planning and Zoning Board (Puerto Rico Urban Planning and Zoning Board Act, No.213, May 12<sup>th</sup>, 1942). This was Tugwell's most cherished project and a pioneering agency in Latin-America. The purpose of the Board was to "...guide the development of Puerto Rico in a coordinated, adequate and economical way, ...according to the present and actual necessities and human and economic resources... in the distribution of population, land use and public works...". Other Agencies created by the Government in 1942 were the Compañía de Fomento de Puerto Rico/Puerto Rico Development Company (PRIDCO); the Banco Gubernamental de Fomento de Puerto Rico/Puerto Rico Government Development Bank, the Autoridad de Tierras/Land Authority, the Autoridad de Hogares/Homes Authority and the Autoridad de Fuentes Fluviales/Sewer and Aqueducts Authority of Puerto Rico. These new government agencies sought to push and control the new social and economic reforms in the Islands.

<sup>50</sup> For a complete overview and history of the Committee on Design and Public Works, see Santiago Gala Aguilera, "El Comité de Diseño de Obras Públicas 1943-1948" *Entorno 7: Colegio de Arquitectos y Arquitectos Paisajistas de Puerto Rico* (2007): 24-28.

<sup>51</sup> Styles ranged from the imported Spanish mission style by way of California, to the French and Spanish Revivals, as well as Art Deco. Also, Victor Pérez Escolano alludes on how the United States invasions to Cuba, Dominican Republic/Haití and Puerto Rico during the 20th Century allowed the dissemination of stylistic trends and construction technologies that benefited American corporations within the establishment of Public Works Departments. Victor Pérez Escolano, "A European Glance in the Mirror of Caribbean Modern Architecture", *DoCoMoMo International Journal*, no. 33 (September 2005): 87. Also, see Enrique Vivoni Farage, "Modern Puerto Rico and Henry Klumb", *DoCoMoMo International Journal*, no. 33 (September 2005): 30.

<sup>52</sup> Ironically, the U.S. Federal Government used Spanish Revival and other architectural historic styles since the early 20<sup>th</sup> Century as an ideological tool.

<sup>53</sup> Architectural historians have pointed out, the Committee on Design of Public Works not only served from 1943-1948 as an architectural production space for public projects that moved to fulfill the needs of the population, but the Committee also intended to serve as an educational entity for architects while introducing new rationalist

---

and functionalist design techniques, aided by foreign architects. Santiago Iglesias, Jr, a fervent follower of Le Corbusier's ideas and an influential member of the Committee's Board, strongly supported the Committee's policy of hiring foreign architects. In 1944, the Committee hired architect Richard Neutra, who was serving as President of the *Congrès International d'Architecture Moderne* (CIAM) at the time, as a design and planning consultant for the public projects (Neutra worked from California as a consultant for the Committee). That same year, Henry Klumb, a German-born architect and Taliesin Fellow, was hired to oversee the Design Division of the Committee. Stephen Arneson, disciple of Frank Lloyd Wright, was another architect that served as Advisor and Technical Director to the Committee on Design of Public Works since 1943. The Committee on Design of Public Works, a technical and theoretical school for local architects that also hired foreign architects, promoted an extensive infrastructure program for the Puerto Rico. The projects included hospitals, drainage and sewer facilities, wharfs, schools, bridges, cemeteries, jails, libraries, markets, parks, plazas, city halls, and sports facilities, among other projects. The Insular Government quickly launched a Puerto Rico into a transformation through its new architecture, a quick and dramatic transition from a mostly agrarian society to an industrialized one. While on the Committee, Neutra developed designs for school units, health centers, and communal areas in rural zones. His valuable contributions to architecture in Puerto Rico can be seen in a 1948 publication titled 'Architecture of Social Concern', which states the importance of tropical climate as an asset for designing economical and healthy architecture for the region. Klumb, as the head of the Design division, not only learned about the Puerto Rican context, but began to develop his ideas in relation to Wright's teachings on organic architecture and its consideration and integration in designs for city halls, vocational schools, and its most innovative project yet, the Zero-Plus housing for rural areas. Both architects' approach to the design of modern architecture for the tropics became key characteristics of their private practice, as well as, a major influence for local architects. See Vivoni Farage, "La Arquitectura de Toro y Ferrer y Henry Klumb," 16, and Gala Aguilera, "El Comité de Diseño," 24 & 26. Also, Dr. Luz Marie Rodríguez discusses how foreign architects, from a Colonial perspective, saw the tropics' climate as a concern that they must address in architecture, while both Neutra and Klumb did the opposite. Rodríguez, "¡Vuelo al Porvenir!," 106.

<sup>54</sup>"...el gobierno aprobó la creación del Comité con el propósito de preparar, durante los años de la Segunda Guerra mundial, planos completos para la construcción de un Puerto rico nuevo. el Comité pretendía desvincular estilísticamente su producción arquitectónica de lo que las otras agencias del gobierno producían.", in Enrique Vivoni Farage, "La Arquitectura del movimiento moderno en Puerto Rico: La obra de Toro y Ferrer y Henry Klumb", Editorial Online (July 2012): 7. Translated by the Author.

<sup>55</sup>Dr. Jorge Lizardi provides a complete analysis of the architecture of warfare in Puerto Rico in his essay "Paisajes de la contingencia: Arquitectura y urbanismo en San Juan, 1938-1948". See Jorge Lizardi Pollock, et.al., Paisajes de la contingencia: Arquitectura y urbanismo en San Juan, 1938-1948" in *Puerto Rico en la segunda Guerra mundial: el escenario regional*, ed. Jorge Rodríguez Beruff and José L. Bolívar Fresneda (San Juan, PR: Ediciones Callejón, 2015).

<sup>56</sup>In his essay, Dr. Jorge Lizardi Pollock points out how the Soviet Union sought to expand its sphere of influence after World War II in Asia, Europe and Latin America, leading the United States and other European countries in the creation of the North Atlantic Treaty Organization (NATO). Jorge Lizardi Pollock, "Daños colaterales: utopía, ciudad y suburbio en tiempos de Guerra Fría (1942-1972)" in *Tiempos Binarios: La Guerra Fría desde Puerto Rico y el Caribe*, ed. Manuel R. Rodríguez Vazquez and Silvia Álvarez Curbelo, (San Juan, PR: Ediciones Callejón, 2017).

<sup>57</sup>Historians point out the development of the Caribe Hilton Hotel in San Juan by the architectural firm Toro y Ferrer and the new Casino of Puerto Rico in Condado by architect Rafael Carmoega as decisive examples for the development of a 'modern' architecture in Puerto Rico. The Government of Puerto Rico sought to the open the most modern hotel on the Caribbean and for that purpose they sent a call for proposals to any interested hotel companies. Only Hilton Company responded. The firm Toro & Ferrer won the competition for the design of the Caribe Hilton which opened in 1946. For a further discussion see Torres-Santiago, "La Inversión de los umbrales..."

<sup>58</sup>Dr. Jerry Torres mentions that one crucial condition on the contract for the construction of the Caribe Hilton was that "*All the concrete[cement] to be used in the construction shall come from factories in Puerto Rico, while the roof tiles, sanitary equipment, cement blocks, and floor tiles manufactured in the ceramics factory belonging to the Puerto Rican Industrial Development Corporation shall be purchased for the building finish. Likewise, all furnishings, the frames for doors and windows, shall be purchased from local manufacturing firms.*" Jerry Torres-Santiago, "La Inversión de los umbrales," 146. Both, the Caribe Hilton and the Casino projects represent the Government's policies of the era that looked on for an Open access to the U.S. market/incentivizing foreign (mostly American) capital in Puerto Rico, tax exemptions, and lower wages, along with the intentions to make a



---

visible new architecture. Along this, Cesar J. Ayala & Rafael Bernabé highlights the shift from the PPD since 1948. The PRRA and Tugwell projects incentivized state sponsored factories, including the Puerto Rico Cement Corp. in Cataño. After 1948, the PPD proposed to attract foreign investing by giving up to 17 years of state tax exceptions to corporations who had moved to Puerto Rico and already paid no Federal taxes. For further discussion see Cesar J. Ayala and Rafael Bernabé, *Puerto Rico in the American Century: A History since 1898* (Chapel Hill, NC: University of North Carolina Press, 2007), 189-190 & 288.

<sup>59</sup> Rodríguez, “¡Vuelo al Porvenir!,” 190.

<sup>60</sup> On July 25<sup>th</sup>, 1952, after years of negotiations with the U.S. Congress, Puerto Rico finally had its own constitution. However, the relationship of the Islands as an unincorporated territory of the United States remained the same. The policy models put in place by the Partido Popular (PPD) and Muñoz in the second half of the 1950s were important, especially since the U.S. and Soviet relations had deteriorated. See Rodríguez, “¡Vuelo al Porvenir!,” 192.

<sup>61</sup> Some of these corporations included Guillermo García y Cástulo Fermint, Concrete Industries, Inc., Caribbean Construction Industries, Atlantic Products, Inc. Puerto Rico Concrete Products, Inc., Ponce Concrete Products, South Puerto Rico Concrete Works Inc., Mosaicos Borinquen, Western Construction Inc., Cement Products Inc., Candelario vera & Bayamón Concrete Industries. Baralt, *Una de Cal y Otra de Arena*, 232-233.

<sup>62</sup> Henry-Russell Hitchcock, “Latin-American Architecture,” *Journal of the Royal Society of Arts* 104, no. 4973, (March 1956): 344-356.

<sup>63</sup> Lizardi Pollock, et.al., “Paisajes de la contingencia”.

<sup>64</sup> In 1946 the newly appointed Governor, Jesús T. Piñero, invited Leonard D. Long, one of the most successful housing developers in the United States, to build the first private-owned residential complex on the island locally known as ‘Urbanización.’ Other developments included Caparra Heights in Río Piedras with over 500 houses, and Puerto Nuevo in San Juan in which over 2,000 houses. The construction of Urbanización Puerto Nuevo housing development between 1947 and 1949 was Long’s largest project in Puerto Rico. Urban Planner Anibal Sepulveda points out that Long’s arrival introduced the modern developer as a professional of the construction field in Puerto Rico. Also, in that era, the PPD dominated Insular Legislative Assembly along with Governor Piñero had passed the Industrial Incentives Act of 1947 (Act No. 346 of May 12<sup>th</sup>, 1947), which incentivized the ‘industrialization by invitation’ policies. This Act allowed the government to sell all public owned factories opening the pathway for Muñoz’s Operation Bootstrap. See Aníbal Sepúlveda, *Puerto Rico urbano: Atlas histórico de la ciudad puertorriqueña*, vol 4: 1920s-2000s (San Juan, PR: Centro de investigaciones CARIMAR, 2004), 66 & Francisco Catalá-Oliveras, *Promesa rota: Una mirada institucional a partir de Tugwell*, (San Juan: Ediciones Callejón, 2013), 117.

<sup>65</sup> Bernabé and Ayala mentions that “By the summer of 1950, 80 new industrial plants were in operation; by 1952, that number increased to around 150. In 1956, the income generated by the manufacturing sector exceeded that of agriculture for the first time.” *Ibid.*, 190.

<sup>66</sup> “...se pretendió hacer una “revolución pacífica” como respuesta local a los movimientos revolucionarios latinoamericanos... [Se buscaba] una ruptura con el pasado (lo que éramos) y una definición de futuro (lo que seríamos).” Jerry Torres-Santiago, “La Invención de los umbrales,” 145. Translated by Héctor J. Berdecía-Hernández.

<sup>67</sup> This period of expansión lasted until 1971. Raúl Cartagena, “El Control de los precios,” 40.

<sup>68</sup> *Ibid.*

<sup>69</sup> Portland Cement production by Barrels: 1939 – 324,243; 1957 – 5,501,000; 1958 – 4,862,000; 1959 – 5,324,000; 1960 – 5,415,000; 1961 – 6,070,000; 1962 – 6,365,000 & 1963 – 7,171,00. *Ibid.*, 49.

<sup>70</sup> *Ibid.*

<sup>71</sup> Baralt, *Una de Cal y Otra de Arena*, 294.

<sup>72</sup> Foreign architects invited by the Government of Puerto Rico to the Islands such as Stephen Arneson, Mason Barr, Richard Neutra, Joseph Blumenkranz, Henry Klumb, Frank Beck, Simon Breines, Isadore Rosenfield, and Paul Schum, among others.

<sup>73</sup> See Jorge Rigau, “Architecture of the 1960s in Puerto Rico, 1958-1972”, National Register of Historic Places Multiple Property Documentation Form (San Juan, PR: Jorge Rigau Architectos PSC, July 3<sup>rd</sup>, 2019), 41.

<sup>74</sup> Rev. Edward J. Suftin and Maurice Lavanoux “Contemporary Catholic Architecture” in *Modern Church Architecture: A guide to the form and spirit of 20<sup>th</sup> century religious buildings*, ed., Albert Christ-Janer and Mary Mix Foley (New York: McGraw Hill Book Co., 1962), 60.

---

<sup>75</sup> Randall Smith, "Don't Blame Vatican II: Modernism and Modern Catholic Architecture," *Sacred Architecture* 13 -The Institute of Sacred Architecture (2007), <https://www.catholicculture.org/culture/library/view.cfm?recnum=8000>.

<sup>76</sup> Suftin and Lavanoux, "Contemporary Catholic," 2.

<sup>77</sup> *Ibid.*, 4.

<sup>78</sup> *Ibid.*, 12.

<sup>79</sup> Since the mid-1930s, various factors influenced the use of reinforced concrete by Le Corbusier including economy, workmanship standardization, and the use of materials by their textural quality on architecture. Later, post-World War II shortage of traditional building materials in Europe along the great technological advancements aided its widespread use. *Ibid.*

<sup>80</sup> Susan Macdonald, "Authenticity Is More than Skin Deep: Conserving Britain's Postwar Concrete Architecture," *APT Bulletin: The Journal of Preservation Technology* 28, No. 4 (1997): 38.

<sup>81</sup> Efraín Pérez Chanis, "Arquitectura Religiosa en Puerto Rico," *URBE* 32, (December 1968-January 1969): 24-25.

<sup>82</sup> Christ-Janer and Mix Foley, eds., "Modern Church Architecture," 6.

<sup>83</sup> *Ibid.*

<sup>84</sup> Del Cueto "Concrete Block Tile," 98.

<sup>85</sup> Thomas S. Marvel, "Cómo fue concebido el libro de La Arquitectura de Templos Parroquiales en Puerto Rico." *Patrimonio* 5, Oficina Estatal de Conservación Histórica de Puerto Rico/Puerto Rico State Historic Preservation Office (2012), 63.

<sup>86</sup> Christ-Janer and Mix Foley, eds., *Modern Church Architecture*, 4.

<sup>87</sup> The Dominican Fathers settled in Puerto Rico in 1511 and aided Juan Ponce de León and the Spanish Crown on the conquest and Colonization of Puerto Rico before any other Catholic religious order in the New World. See fray Mario Rodríguez León, "Historia de los frailes dominicos en Puerto Rico: 1509-2009," *PReb* (blog), 2009, <https://www.preb.com/devisita/domenpr.htm>

<sup>88</sup> Between the 1960s and 1980s the Catholic church founded three additional Archdioceses in Puerto Rico: The Archdiocese of Arecibo (1960), the Archdiocese of Caguas (1964) and the Archdiocese of Mayaguez (1976). See Arnaldo Gierbolini Rodríguez, "Resumen de la Historia de la Iglesia en Puerto Rico y esbozo de las historias diocesanas" (Paper presented at the Primer Encuentro de la Asamblea Nacional de Pastoral in Casa Manresa, Aibonito, PR, June 4-6, 2011), 13-15.

<sup>89</sup> Balvanera provides a good overview of these and other modern churches of the era up to the 1990s in Puerto Rico. See Héctor Balvanera Alfaro, "Arquitectura Religiosa de las Parroquias de la Arquidiócesis de San Juan de Puerto Rico, 1965-1995" (master's tesis, Universidad Popular Autónoma del Estado de Puebla, 2019).

## **CHAPTER 2**

### **The Churches of Modernity, Architect Henry Klumb & the Parroquia Nuestra Señora del Carmen**

“However, uncommon for a foreign architect working in a colonial context, Klumb looked at difference[s] as design resource[s], not as problems to be solved. In that respect, Klumb does not seem to approach Puerto Rican culture, climate, and environment as implicit inferiors, as was the norm in colonial spaces, but as ways to give form to another type of essence.” -Dr. Luz Marie Rodríguez, 2016<sup>1</sup>

#### **2.1 Henry Klumb, the architect and his churches**

Heinrich 'Henry' Klumb (1905-1984) uniquely exemplified the fusion of organic architecture principles in the Caribbean region, which included modernist ideas. A German-born architect, Klumb excelled as an industrial designer and architect. Opposed to an International Style and a radical critic of modern architectural production in the 1950s, Klumb designed over 300 projects resulting from profound theoretical inquiries and using environmental systems as a determinant for design. Well-traveled, Klumb studied at Staatliche Bauschule School of Architecture in Cologne, Germany, where he learned about American architect Frank Lloyd Wright. Upon his arrival in the United States in 1928, where he encountered a hostile pre-WWII environment toward Germans, Klumb wrote to Wright and expressed his deep admiration for his work. In 1929 Wright invited him to Taliesin West to be a part of the first class of Fellows working in his private studio.



*Fig. 2.1* – Architect Frank Lloyd Wright and young Henry Klumb at Taliesin West in the 1920s. Source: AACUPR – Henry Klumb Collection.

From 1929-1933, Klumb became Wright's 'right arm' and later, chief draftsman at Taliesin.<sup>2</sup> There, he designed several international exhibitions, including the first European exhibition of Wright's work, and eventually presented Wright's ideas to the European architectural community. Since 1932, as Wright tailored the idea of opening an architecture school, Klumb had the responsibility of mentoring and taking charge of new disciples.<sup>3</sup> In Taliesin, using hollow concrete block, cement, and steel rebar reinforcement, Klumb learned firsthand how materials and tectonics were a key part of Organic Architecture philosophy and how these physically helped to shaped those ideas.<sup>4</sup>

After leaving Wright in 1933 due to differences with the master, Klumb worked in several areas of the United States for a decade before arriving in Puerto Rico. His experience as an exhibition designer for the U.S. Bureau of Indian Affairs and his experimental designs for affordable (minimally prefabricated) housing in partnership with Louis Kahn, Alfred Kastner, and Louis Magaziner were some of his most notable projects

during this period. In 1942, Klumb worked with Alfred Kastner and David Humphrey in the architecture and planning firm called Cooperative Planners.<sup>5</sup>

In 1944, at the same time the Portland cement and reinforced concrete industry was booming in Puerto Rico, Klumb was invited by his former co-worker, now Governor Rexford G. Tugwell, to direct the Design Division of the newly created Comité de Diseño de Obras Públicas/Committee on Design of Public Works (CDPW) in the Islands.<sup>6</sup> In the CDPW, Klumb studied the local environmental and cultural conditions of Puerto Rico and developed his first significant public designs. As he became enamored with the people and landscapes of 'la Isla del Encanto'/'Isle of Enchantment,' Henry Klumb studied its traditional rural communities and their architecture. After establishing his private architectural practice in San Juan, he continued to work in both public and private spheres until his sudden death in 1984. Klumb's work shows how he developed sensible and appropriate design approaches for the tropics while looking to improve the living conditions of Puerto Ricans.



*Fig. 2.2* – Henry and his wife, Elsie Klumb standing outside of their famous House-*Casa Klumb*, which was listed in 1997 to the National Register of Historic Places and destroyed by a fire on November 2020. He renovated a historic Hacienda from the second half of the 19<sup>th</sup> Century in 1947 integrating all the principles of Organic Architecture. The House Source: AACUPR – Henry Klumb Collection.

Despite being a critic of the 'Modern Architectural Movement' in Puerto Rico, Klumb was designated the 'father of Puerto Rican modernism' by architectural historians and has been identified as a role model of an entire generation of local architects.<sup>7</sup> His work ranged in designs for both public and private clients. In his public practice, in addition to being head of the Committee on Design of Public Works, he was also a member of the Autoridad de Hogares de Puerto Rico/Puerto Rico Housing Authority and the Chief Architect of the University of Puerto Rico for two decades. His private practice included numerous residential, offices, and commercial buildings throughout Puerto Rico and the U.S. Virgin Islands, as well as pharmaceutical offices and factory buildings in both Puerto Rico and the United States. Still, Klumb's Catholic churches in Puerto Rico are among his most praised work.



*Fig. 2.3* – Social Science Faculty Building, UPR Río Piedras, San Juan, PR (1964). Source: AACUPR – Henry Klumb Collection.



Fig. 2.4 – Hotel La Rada in San Juan, PR (1950). Source: AACUPR – Henry Klumb Collection.



Fig. 2.5 – Park Davis & Company Building in Carolina, PR (1959). Source: AACUPR – Henry Klumb Collection.

Klumb designed the first modern buildings for the Catholic church in Puerto Rico through his collaboration with the Dutch Dominican Order. His *Santa Rosa de Lima Chapel*, built-in 1946 in Guaynabo, inaugurated a long collaborative relationship of the

architect with the Dominicans. Built-in 1953, the *Sanctuary of the Blessed San Martín de Porres* (listed on the National Register of Historic Places in 2017) located in Bay View, Cataño, is known as the first modernist church in Puerto Rico and is among the earliest modern churches designed in Latin America. It became his most famous religious building.<sup>8</sup>



*Fig. 2.6* – The Sanctuary of Blessed San Martín de Porres in Cataño. Photo by Author, August 2019.

*Fig. 2.7* – Nave at the Sanctuary of Blessed San Martín de Porres in Cataño. Source: AACUPR – Henry Klumb Collection.





According to Luz Marie Rodríguez in her National Register nomination for the San Martín de Porres Church, it was the influence of Father Marcolino Maas, who advocated the use of a new modern architecture for the church, "...*Catholic faith as such, does not necessarily build good churches, 'God-worthy' churches; only talent and honest craftsmanship can.*"<sup>9</sup> In the design of this temple, Klumb displayed his mastery of reinforced concrete as an expressive building material fulfilling the Dominican Order's and the public's needs with its design.<sup>10</sup> In 1955, renowned architectural historian Henry Russell Hitchcock praised Klumb's work in his publication *Latin American Architecture since 1945* as:

“...the only ecclesiastical modern structure of any quality built in Latin America since Oscar Niemeyer's Church of San Francisco in Pampulha, Brazil (1943) and Enrique de la Mora's La Purísima Concepción de María in Monterrey, Mexico (1946).”<sup>11</sup>

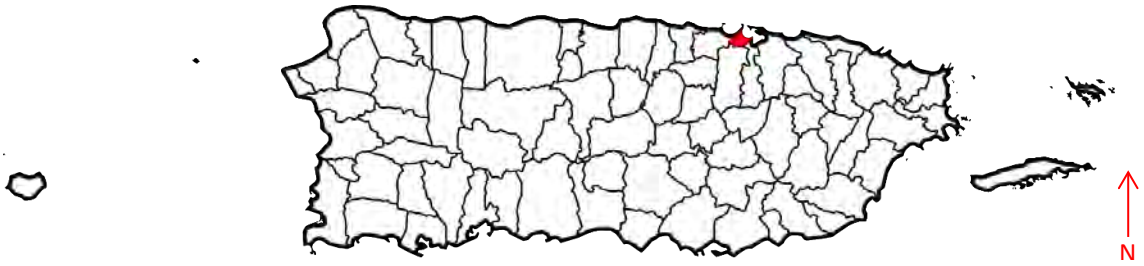
Klumb's successful relationship with the Dutch Dominican Order and the Catholic Church earned him two more projects: the *Dominican Seminary*, the Dominican Order's headquarters in Hato Tejas, Bayamón, and the *Parroquia Nuestra Señora del Carmen*, the parochial church of the town of Cataño.



Fig. 2.8 – Henry Klumb in 1963. Source: *Caribbean Traveler: The Antillean Magazine*, January 1967, AACUPR – Henry Klumb Collection.

## 2.2 Del Carmen Church: its history, design, and construction

The history of the Parroquia Nuestra Señora del Carmen is different from that of other traditional designs of Parish churches in Puerto Rico since they were usually built during or right after the town's foundation.<sup>12</sup> Situated across from San Juan Bay and located on the southern side of the Public Square Plaza in the small town of Cataño, the Del Carmen Church was designed by Klumb in 1961 and completed in 1962. By its exotic curvilinear forms and its exterior finishes, the Church is unique in Klumb's extensive work and is the first Catholic religious building with a centralized plan in Puerto Rico.



*Fig. 2.9* – The islands of Puerto Rico. Cataño, founded officially in 1927, is the smallest Municipality in Puerto Rico and is located on the northern part of the main island.



*Fig. 2.10* – The San Juan bay. Both Cataño and the historic city of Old San Juan share the bay. The municipality is located on the southern side of the bay. Source: Google Maps.



Fig. 2.11 – Aerial photo of Cataño and its plaza facing the bay. Source: Google Maps.



Fig. 2.12 – The city block in which Del Carmen Church stands. Photo by Diana Serrano, December 2019.

Cataño and its public Plaza (also named *Nuestra Señora del Carmen*) meets the traditional Spanish colonial design of the Law of the Indies: a central plaza surrounded by a grid with main rectilinear streets. The parish church stands in the middle of a crowded site together with three other concrete historic buildings: the Rectory towards the west (from 1941), a former bank with apartments on the upper stories on the east side built between the 1930s and 1940s; and the Old Rosa María Arcay Elementary School built in the 1930s on the southeast side. In the 1963 church project description, Klumb explains the design challenges that the site represented;

"The problem of designing a church for a crowded site, flat topography, with irregular boundaries, and with ventilation and orientation problems, suggested the concept of a church with a central altar surrounded by the congregation..."<sup>13</sup>

The church, now part of the Archdiocese of San Juan, was erected facing the square Plaza and the San Juan Bay in a 12,072 sq. ft lot.<sup>14</sup> With its exuberant forms and over 40 feet in height, it still fits perfectly with the urban scale of Cataño, sometimes passing as a discrete building within its surroundings.



*Fig. 2.13 & 2.14 – Del Carmen Church within its urban context. Photos by Diana Serrano, December 2019, & the author.*

The origins of the Del Carmen Church go back to 1779 when the Ermita de La Candelaria was founded in the Hacienda 'El Plantaje,' a sugarcane hacienda located between the towns of Cataño and Toa Baja. By Royal Decree dated May 6<sup>th</sup>, 1852, the Spanish crown authorized the establishment of the Compañía Puertorriqueña del Vapor

Cataño or a Ferry Service, which would connect Old San Juan with the town of Cataño in the San Juan Bay through steamboats. The Company established a village near its docks and, in 1850, donated lands south of the public Plaza for the construction of a small chapel. In 1864, the people of Cataño built a small wooden chapel with a thatched palm roof (later changed to zinc plates) that would be administered by the area's Parochial Church (Santa Cruz in the Municipality of Bayamón). From 1864-1889 the Chapel stood by itself in the middle of a city block. In 1889 Cataño's neighbors requested permission for the development of the lands surrounding the Chapel. The town's mayor, the Bayamón city administration, the engineer, and the head of Public Works approved the request.<sup>15</sup>

In 1893, a canonical authorization provided the necessary support to establish a Parish Church in Cataño that no longer needed to respond to Bayamón. Hurricane San Ciriaco of 1899 damaged the original wooden church, and as a consequence, between 1904-1905, the people of Cataño worked together to build a new rubble masonry three-nave church.<sup>16</sup> During this same period, the Dominican friars from Holland, coming from Curaçao, took charge of the Del Carmen Church.<sup>17</sup> Between 1905 and the 1940s, several hurricanes adversely affected the building leading to continued significant repairs and renovations. In 1927 the Insular Legislative Assembly formally created the Municipality of Cataño as an independent municipal government from Bayamón. From the 1930s through the 1950s, the town's population grew as well as its industrial importance.<sup>18</sup>



*Fig. 2.15* – The old Del Carmen Church building from 1904-1905, c.1950. The belfry was seriously damaged by Hurricane Santa Clara in 1956 and was removed. Source: AACUPR – Henry Klumb Collection.



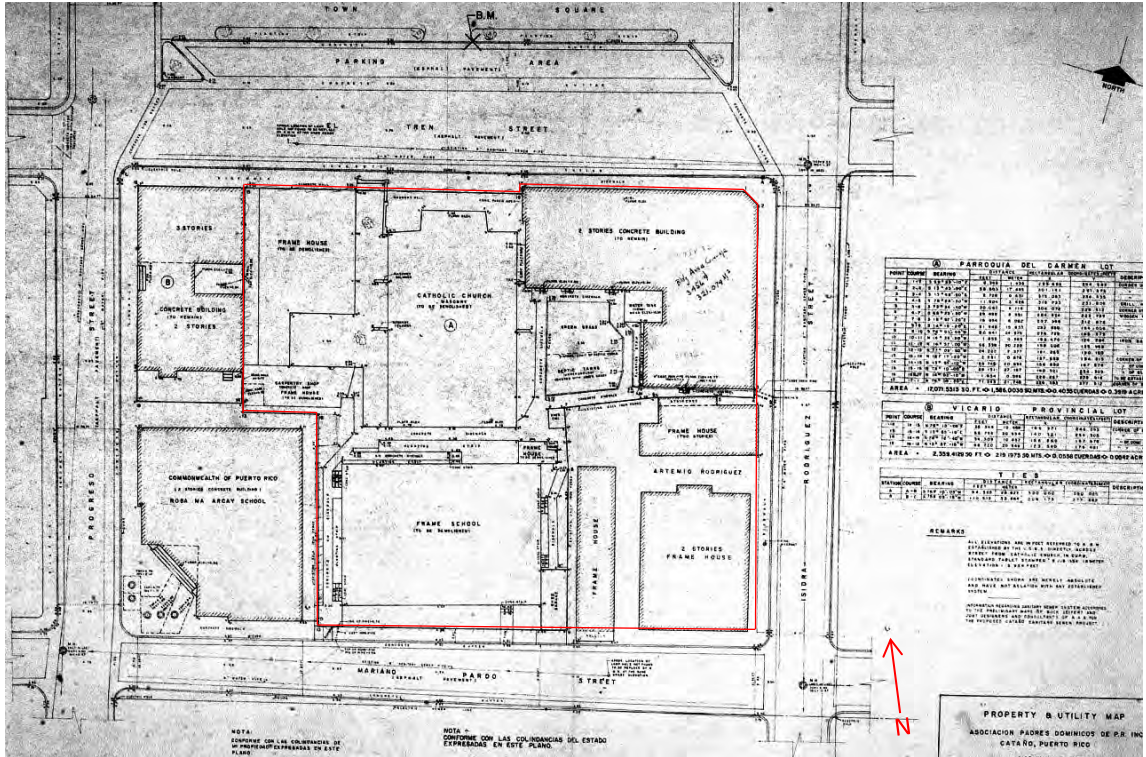


Fig. 2.16 – Del Carmen Church site plan from 1958 before the construction of the new church. Source: AACUPR – Henry Klumb Collection.



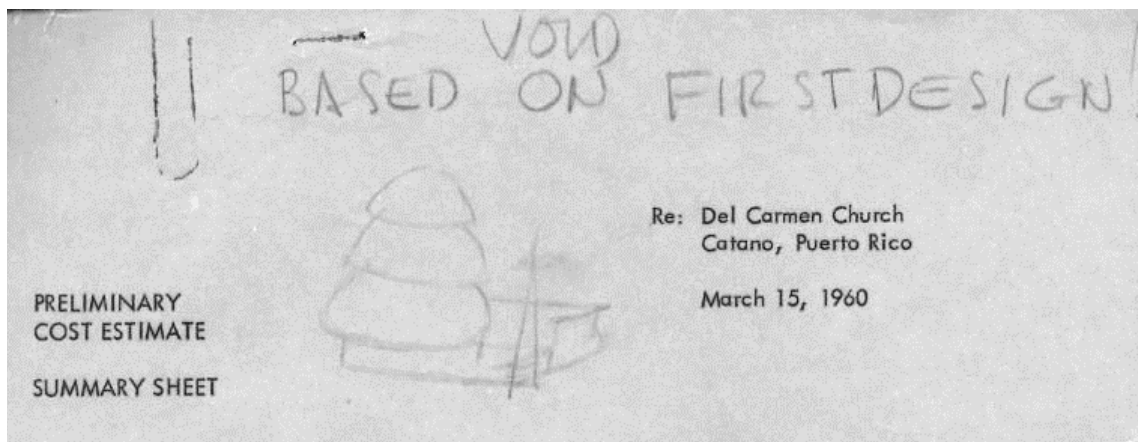
Fig. 2.17 – The Nuestra Señora del Carmen Plaza in Cataño, c.1957-1958. The old church can be seen standing to the south side of the Plaza. Source: AACUPR – Henry Klumb Collection.



Fig. 2.18 & 2.19 – The Del Carmen Church originally occupied half of the present day lot. One of the original wooden houses in the Town was demolished to make space for the new church. Photos c.1957-1958. Source: AACUPR – Henry Klumb Collection.

In the 1950s, the Dominican Order decided to expand Del Carmen Church. The need for a bigger space to celebrate weekly worship services for the town's growing congregation necessitated the demolition of the existing church and the construction of a new building.<sup>19</sup> Henry Klumb's success with the Sanctuary of the Blessed San Martín de Porres church in Bay View granted him another opportunity to work with the *Dominicos*. In 1957, Klumb was initially hired to design an expansion to the original neoclassical church. Eventually, the Church's administration, with the newly appointed Father Lorenzo Booms, O.P. in charge, promoted a completely new design for their Parish Church.

The project started in January 1959, and from the beginning, the priests agreed on a central altar for the design. Worried about their past issues with leaks, mold, and maintenance of the wooden roof from the 1905 building, the priests agreed to a proposed high dome that would cover the central nave of the church along with other spatial arrangements. From the beginning of the project, Klumb worked closely with renowned Estonian-American Engineer August Komendant, who had already worked on other engineering projects in Puerto Rico since the early 1950s. His relationship with Klumb began in 1955 when they worked together on the Office Building for Dr. Mario Juliá.<sup>20</sup>



*Fig. 2.20* – An early concept sketch found among the archival records of the Church. Source: AACUPR – Henry Klumb Collection.

In April 1959, along with a \$3,000.00 quote for his services, Komendant sent three different options for the dome and main building:

- Shell 1, a purely hexagonal form;
- Shell 2, with only a hexagonal base and a top with 12 equal sides supported only at the corners of the hexagonal shell 1;
- Shell 3, a circular or polygonal dome supported at the 12 proposed corners of shell 2.

All options used reinforced concrete with variances: Shell 1 would be done in a poured conventional way using forms, while Shell 2 & 3 could be built without forms using the 'Guniting method.'<sup>21</sup> After several discussions and meetings with Father Lorenzo and Father Domingo, they decided on another option: a prefabricated massive ovular dome that would be supported by six massive exterior columns in a hexagonal base. In a special issue of *Progressive Architecture* published in October 1960, Komendant outlined his idea for Del Carmen Church. In a passionate defense for the use of precast systems, while acknowledging its associated costs, the design for the Del Carmen church would have a combination of precast and 'guniting.' In using both techniques, he states that for "such [a] monumental structure the concrete is usually exposed since any type of built-up roofing would spoil its appearance."<sup>22</sup>

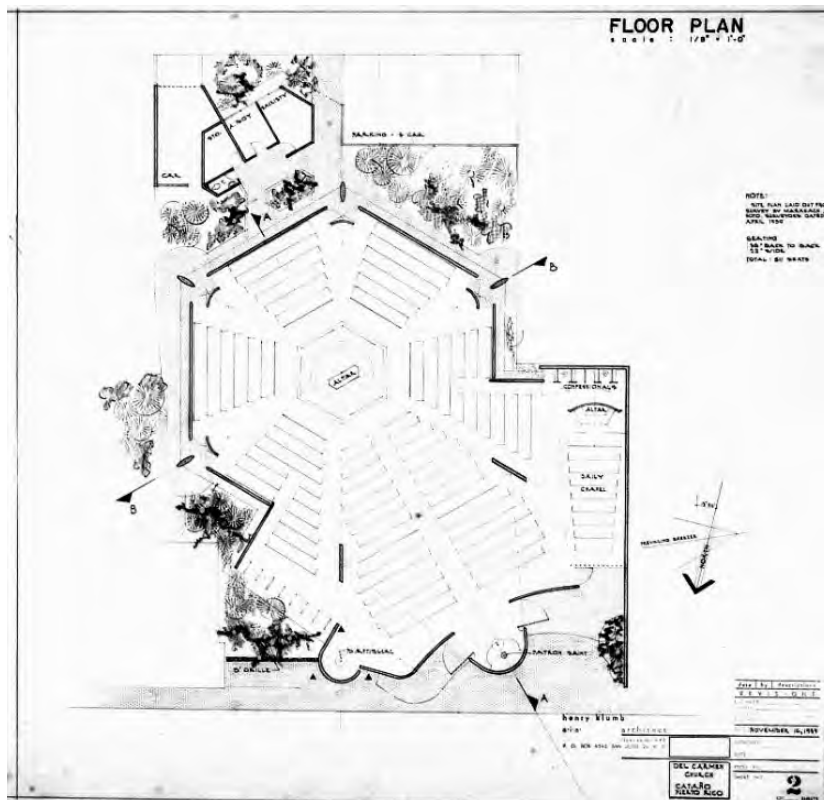
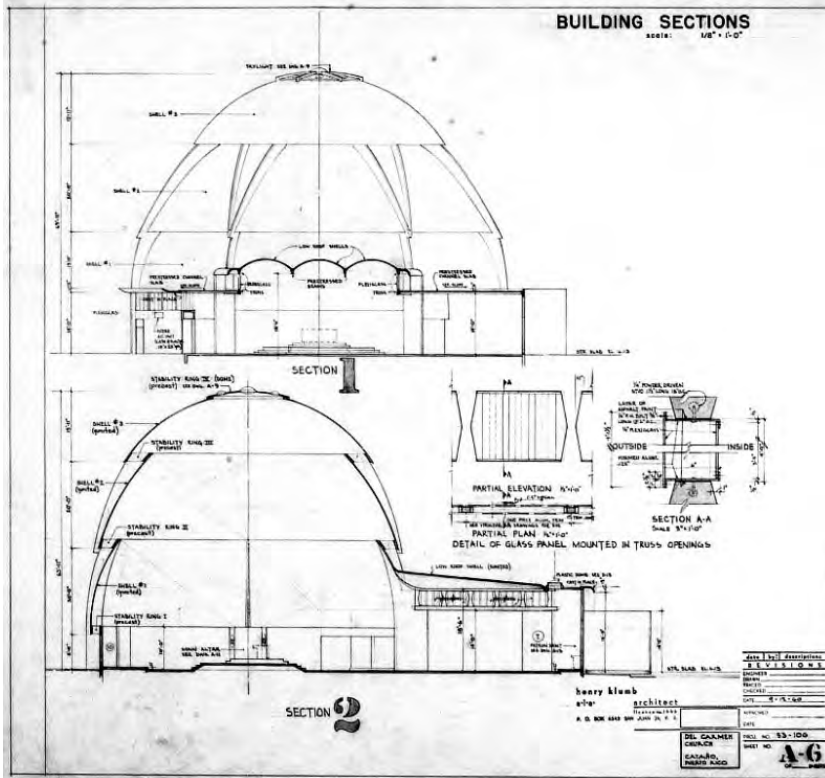


Fig. 2.21 & 2.22 – Early design concept for the Del Carmen Church in 1960. Most of the concrete elements in the building specially the dome structure, would be precast concrete. Source: AACUPR – Henry Klumb Collection.

Some combined shell systems and shells with complicated curvatures can be most easily and economically constructed by combining precast sections with steel grid and guniting method (Fig. 315). This building is composed of four different shells. The lowest and intermediate ones are formed of cylindrical shell sections transmitting the loads, including the

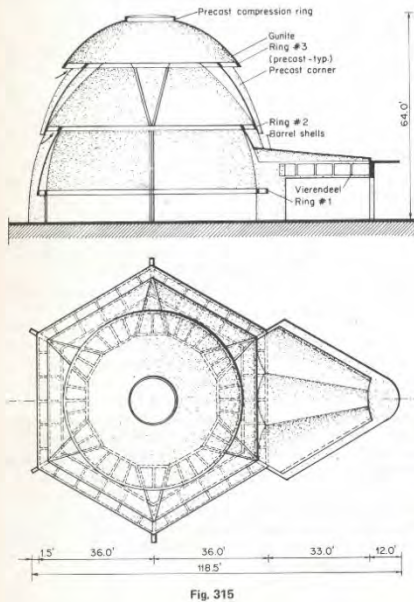


Fig. 315

partial dead load of stability rings, into corners by shell carrying action. The highest shell is a dome with a skylight at the crown. The entrance building is overroofed by barrel shells with linearly varying width and rise. At the horizontal junctions of the shells, Vierendeel-type stability rings are introduced for purposes of ventilation. This is a church intended for a tropical area in which air conditioning is not required and natural ventilation is vital and adequate.\* The design foresees a combined construction method of precasting and guniting. The stability rings and corners are designed as precast units, the proper shape of the structure being established after the precast units are erected and connected by dowels and welding. The curved surfaces between the precast units are established by reinforcing grid welded to dowels projecting from the precast units (Fig. 316). To make the use of gunite possible, the grid is covered with two layers of closely spaced wire fabric.

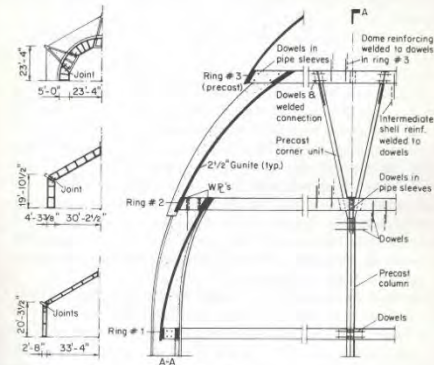


Fig. 316

\* Architect: Henry Klumb; Del Carmen Church, Puerto Rico.

Fig. 2.23 – Even though the 1960 design was never built, Komendant featured the structural drawings and calculations of the original design in his book *Contemporary Concrete Structures* published in 1972. The original calculations can be found at the Komendant Collection in the University of Pennsylvania Architectural Archives. Source: A. Komendant, *Contemporary Concrete Structures* (McGraw-Hill) 1972, p. 501-504.

Klumb's office requested the permits and an endorsement for the demolition of the old 1905 church from the Institute of Puerto Rican Culture between March and April 1959. At the same time, they continued refining the design proposal. On January 14<sup>th</sup>, 1960, the Puerto Rico Planning Board approved the construction project, which helped the project move forward. In February 1960, Komendant worked on different calculations for the proposed dome. Such a complicated project required careful consideration. The Structural Concrete Products Company was selected from the beginning to prepare a quotation for all precast concrete elements and the Gunite applications. After several delays in schedule, the project drawings and construction specifications were ready around November 1960, and on December 13<sup>th</sup>, 1960, Klumb's Office extended an invitation to

bidders for the church's pile foundations. However, on December 19<sup>th</sup>, everything changed. Father Lorenzo requested significant design changes due to the high costs of the project, probably due to the expensive prefabricated concrete elements.<sup>23</sup>

Between January and February 1961, the project was completely redesigned. The original precast egg-like shaped dome was replaced with a smaller scale cast-in-place dome. All precast elements were substituted with traditional cast-in-place reinforced concrete and concrete block. Komendant, more interested in non-traditional concrete technologies, left the project.<sup>24</sup> In April 1961, the local firm Bermúdez, Hernández & Murati Engineers (BHM Engineers) was hired for the structural design of the church. Contractor Carlos Lázaro won the bid with the amount of \$98,695.68 for the total project cost.<sup>25</sup> On May 15<sup>th</sup>, 1961, the construction project began with a Ceremony, which included a blessing and the placement of the 'first stone.' During that same month, the pile foundations for the building were completed. The construction process lasted for over a year. On June 3<sup>rd</sup>, 1962, the Church was dedicated, and the contract completion for the whole project was dated December 18<sup>th</sup> of that same year.<sup>26</sup>

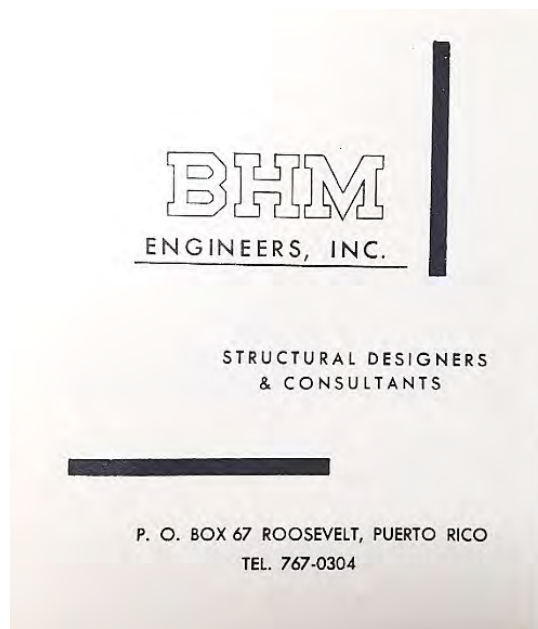


Fig. 2.24 – Bermudez, Hernández & Muratti Engineers announcement featured in the *Proyectos y Materiales* journal. Source: Revista Proyectos y Materiales, Jul-Aug 1949 – Henry Klumb Collection, AACUPR.

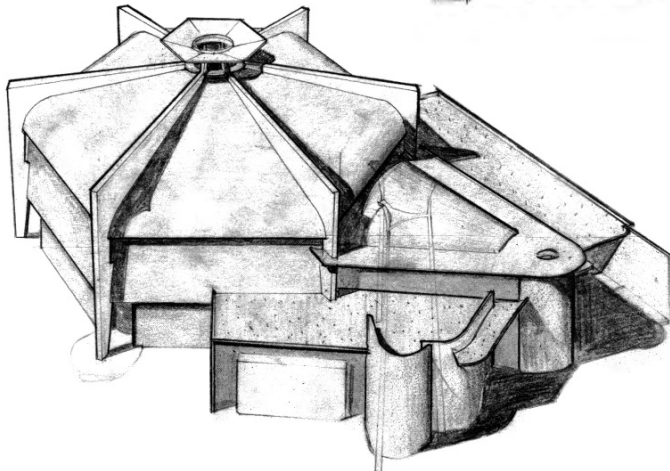
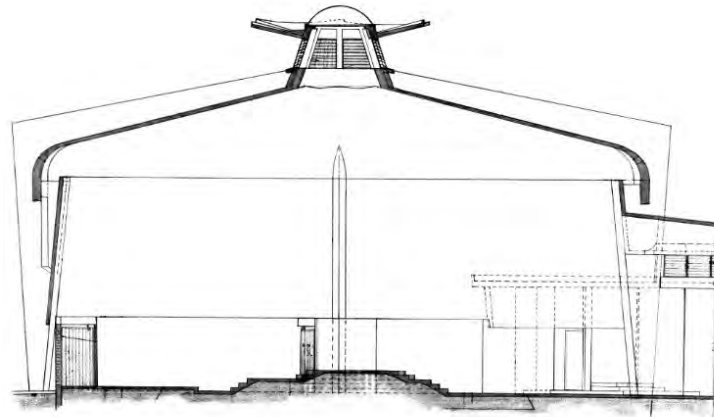
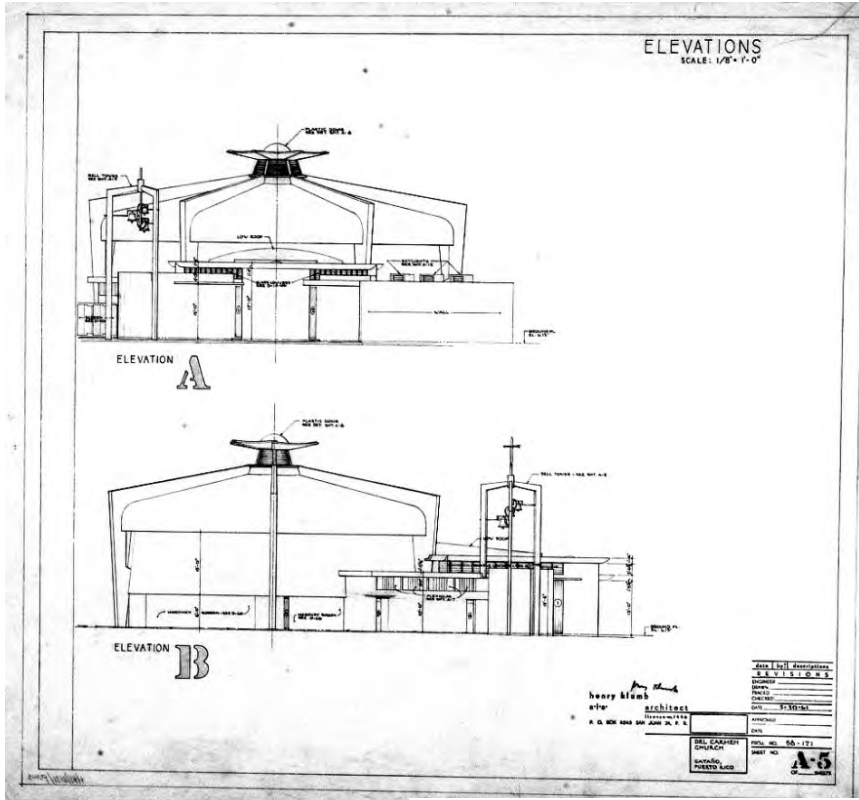


Fig. 2.25, 2.26 & 2.27 – The final design for the Del Carmen Church developed between January and February 1961. Source: AACUPR – Henry Klumb Collection.



The Church's main spaces included a side chapel, two confessionals, baptistry area, patron saint altar, choir area, garden, narthex, and nave or main congregational space. The main altar, originally a central feature, is presently located at the back of the church. A combination of reinforced concrete was used as poured-in-place, concrete block, and precast variations. The February 1961 construction specifications state that the building features reinforced concrete structural members and masonry unit bearing and non-bearing partitions. Poured-in-place systems were used to develop the hexagonal dome, the tilted walls under the dome, the exterior structural columns, and interior floors. Horizontal steel reinforcement was used in the dome with spans of 5 ft by 5 ft. The same steel reinforcement system was applied for the 15-foot-high tilted walls at the east, south, and west facades. The structural columns were erected using vertical, diagonal, and horizontal steel reinforcement anchored within the dome's roof steel rebar. All surfaces were finished with cement plaster and stucco. The specifications also mention that the dome used a 1-inch thick waterproof finish plaster. The overhangs in the roof seen on the north façade were also poured-in-place.<sup>27</sup>

The building is set on a reinforced concrete foundation slab supported by poured-in-place underground 25 feet piles. The original soil report of 1960 described the site as a "sand-covered lagoonal deposit" and 'weak' with a 'very stiff silty clay formation' in the above strata, grey sand in the top layer of subsoil; 1.5 to 4 ft of 'some organic silt, very loose' and 10 to 12.5 of 'organic clayey silt and organic sandy silt.' The report also mentioned that "weak terrain extends up to 22.5 to 26 ft" and that occasional coral and limestone rock fragments could be found. The water table at the site had a depth of 2.5 feet beneath the present ground surface in 1960.<sup>28</sup>

The north façade, facing the Plaza, shows an exuberant continuous and intersecting arrangement of curvilinear concrete block-shaped walls with continuous and

curved, poured-in-place, cap beams.<sup>29</sup> The east side hosts a small entrance court with a concrete block wall, an adjustable wood vertical screen on the left, and a curvilinear planter designed by Klumb, all protected by a steel gate. Three tall pivotal flush hollow redwood doors serve as access points to the church interior. One middle door faces the street, and the two adjoining side doors are located under a small porch space, one leading to the narthex and the other leading into the small chapel.<sup>30</sup> On the west side of the north façade, just to the left of the semi-circular wall and the bell tower, a precast louvered grille wall is found.<sup>31</sup> The belfry marks the main façade with its axis towards the public Plaza. It has three simple linear concrete block posts that meet on the top of the semi-circular wall.<sup>32</sup>



*Fig. 2.28 & 2.29* – The small porch space and the continuous curvilinear north elevation. Photos by Javier Freytes, December 2019.





*Fig. 2.30 & 2.31* – The simple linear concrete block belfry/bell tower (top photo). The nave with the altar in the back (bottom photo). Photos by Javier Freytes, December 2019.



*Fig. 2.32 & 2.33 – A view of the Nave from the south to the north (top photo). The small daily chapel (bottom photo). Photos by Javier Freytes, December 2019.*

The entrances led directly to the narthex, which features a circular plexiglass skylight and a wooden altarpiece dedicated to *Nuestra Señora la Virgen del Carmen* on the back. Two rows of horizontal fixed plexiglass windows on the east and west clerestories remain adjacent to the curved slab roof.<sup>33</sup> Fixed glass panels on the east side of the church divide the nave from the chapel. The small flat-roofed chapel on the west side features a small altar to the south with a curved concrete block wall. Additionally, three skylights provide illumination to space, and an adjustable wood vertical screen and a redwood door both lead to the entrance court on the north façade and the Plaza. Passing through the narthex towards the west side of the church are the confessionals, the patron saint's altar, and a small hidden garden. At the top of the simple and austere wooden confessionals, four open window spaces with four vertical plexiglass louvers per space provide natural illumination to both the narthex and the central nave. The narthex leads to the hexagonal nave space. The dome lantern with a central circular plastic dome skylight is enclosed by six aluminum vertical louvers marking the middle of the open space. Terra cotta hollow block screen walls surround the nave and altar on the lower level and provide the support for five massive poured-in-place tilted walls on the top that almost touch the hexagonal dome.<sup>34</sup> The terra cotta hollow block screen walls provide an excellent source of passive-cross ventilation for the space between the cast-in-place tilted upper walls and the dome.<sup>35</sup> Near each terra cotta hollow block screen, four flush hollow redwood pivotal doors ornamented with fixed colored Plexiglass screens provide access to the south patio.



*Fig. 2.34* – Looking from the Chapel to the narthex and baptistry (northeast side of the church). Photo by Javier Freytes, December 2019.

From the back patio, the architectural features which make up the sculptural exterior of the church can be appreciated in their absolute beauty. A lantern with sloped roof members and vertical aluminum louvers embellish the highest point of the church. A massive poured-in-place-umbrella formed dome, 'trimmed' at the bottom, is supported by six massive vertical poured-in-place structural columns that turn into beams on the dome (only four columns can be seen from the patio). The church is supported by an underground foundation slab that connects the north façade elevations to the structural columns on the south elevations (back patio). Each column serves as important structural support built upon the foundation piles.<sup>36</sup> This structural arrangement leaves the poured-in-place tilted walls as floating elements both inside and outside.



*Fig. 2.35 - The sculptural exterior of the church as seen from the southwest side and the back patio. Photo by Diana Serrano, December 2019.*

The exterior's exposed and unpainted surfaces were finished with Stucco utilizing both troweled and gunite methods throughout the building. These have been painted over for the last 20 years. Other alterations to the church include removal of the initially centered altar (1990s), rearrangement of the pews (1990s), removal of the planters surrounding the terra cotta hollow block screen, and in the clerestory windows, the substitution of the original glass vertical louvers with fixed plastic panels. Besides these alterations, the church retains most of its architectural elements and character-defining features.



Fig. 2.36 – Details of the original exterior stuccoed surfaces on the northeast side of the church, c.1963.  
Source: AACUPR – Henry Klumb Collection.

### 2.3 Klumb's design approach

The Del Carmen Church was designed and built while Pope John XXIII's reign began; the Second Vatican Council had just started to convene and amid an expansion and evolution process of the local Catholic church. Del Carmen Church's design, as Vivoni-Farage states, "marked another way of interpreting the Catholic worship..."<sup>37</sup> Klumb's design; Inspired by European liturgical revival churches, had a tremendous impact on a small traditional-religious community because his project replaced a small neoclassical church built between 1904-1905.<sup>38</sup> Marvel & Moreno's *Architecture of the Parish Churches in Puerto Rico* on the evolution of the religious typology of buildings in Puerto Rico offers a clue regarding the local reception of Klumb's design.<sup>39</sup> For over four centuries, Puerto Ricans saw their parish churches as a traditional vestibule-nave-apse-



chapel, a spatial arrangement that followed European/Spanish medieval traditions. These also included enclosed bell towers, robust walls, vaults, austere facades, wooden roofs, and a traditional rubble masonry building technology. Klumb's spatial and tectonic arrangements, which included a centralized nave, curved tall façade walls, and the umbrella-shaped dome design, can be considered radical alternative. As is common with modern architecture, the replacement of the old parish church caused controversy among the congregation and citizens of Cataño, leading to significant criticism and hard feelings that remain presently.<sup>40</sup> Still, the congregation and people of Cataño recognize Del Carmen Church as a significant local and statewide reference point and a proud example of architect Henry Klumb's work

Del Carmen Church can be considered not only an "early example of *béton brut* use," but also a building that contributes to modern religious architecture trends from the 1960s and the maturity of Klumb's design concepts from previous churches.<sup>41</sup> The diagonal organizing gesture and the naves' hexagonal plan can be seen as a response to influences from both Klumb's formative years with Wright as well as the design trends from the 1960s. Architectural historian Neil Levine argues that since 1929, Frank Lloyd Wright's 'use of diagonals became a specific spatial theory' where a triangular and hexagonal grid became a compositional organizational tool. Klumb's gesture of a diagonal narthex and entrances facing the Plaza is mostly a tribute to environmental concerns and cross ventilation. The use of diagonal axis for the floor plan, belfry, structural members, entrances, along with the hexagonal shaped nave, can be considered part of 'Wrightian' thought, which organized the church's spatial configuration.<sup>42</sup> On the other hand, architect Jorge Rigau argues that hexagonal figures had a remarkable influence among international designers and, in a certain way, influenced local Puerto Rican architects and practitioners' tastes and their will to experiment during the decade.<sup>43</sup> Moreover, design

experimentation with geometrical figures such as fan-shapes, circles, squares, ovals, and trapezoids was favored by architects of the era to organize a congregation around centralized altars.<sup>44</sup>

The arrangement of a central altar for the Church can also be explained by modern religious design influences of the time both by the liturgical movement as well as Klumb's 'life core' concept. Most publications related to modern Catholic religious architecture credit the Second Vatican Council of October 1962 as one of the leading forces behind centralized altars in modern churches from the era. Still, architects in Europe and the United States materialized those ideas from the Liturgical Renewal Movement in the built environment long before 1962. In the first half of the twentieth century, the Church of St. Leopold in Vienna by Otto Wagner (1903), St. John Church at Manheim by Curjel and Moser (1904), the Church of St. Mary in Spanday by Christoph Hehl (1900), St. Willibald Church by Hansjakob Lill (1957), the Parish of the Sacred Family by Rudolf Schwarz and Josef Bernard (1958), and Saint Mark's Church in Burlington, VT by Freeman, French and Freeman Architects (1944), are all examples of religious buildings with plans that relied on central altars. Klumb's archives show how American and German designs for churches were present in the architect's mind.<sup>45</sup> In an article from the September 1944 issue of *Architectural Record*, Brother Cajetan Baumann, O.F.M. talks about the importance of the altar as an essential element for the Catholic liturgy and the trends from architects of the era towards their design:

"There is no element in a church more essential to worship than the altar, for, without it, Mass cannot be celebrated. Neither the congregation nor the cross, neither the pulpit nor the baptistry, demands our attention as much as the altar does. Architecturally it must be the central point of the interior of the church toward which all eyes must be turned. The altar can make or mar the beauty of the entire edifice. All else must be subordinated to it. The eye and the mind must be led immediately towards it...There is a welcome

trend toward so placing the altar that the congregation, rather than facing it from one direction only, in effect gathers around it..."<sup>46</sup>

Klumb, influenced by these ideas on the centrality of the altar from the Liturgical Revival movement in the United States and abroad, broke with the traditional rectangular floor plan in both San Martín de Porres (1946) and the Del Carmen church design. On the other hand, in response to Wright's teachings of organic architecture, Klumb developed the 'life core' concept during his days working for housing proposals in Washington, D.C. While this concept might not seem applicable for Del Carmen from a traditional perspective, a sense of that idea can be found in the church's design. The church, as a worship shelter, hidden from the commotion of the Plaza, creates a living worship space. The concept is visible through the central altar as the 'utility unit' and thus the pulsating center from which all religious services and comfort mechanisms are arranged, all adapted to both environmental conditions and the site.<sup>47</sup>



*Fig. 2.37* – The original spatial arrangement of the nave with a central altar c.1963. All mahogany pews (also designed by Klumb) surrounded the altar and the space was illuminated by custom-designed lamps. Indirect illumination (with bulbs) between the tilted walls and the dome was part of the illumination system for the space. Source: AACUPR – Henry Klumb Collection.

Klumb saw the tropical Caribbean environment and climate as an asset rather than a burden for his designs.<sup>48</sup> Following his teachings from Wright, Klumb made clear his design philosophy and its relationship with the environment:

"Architecture in its reality of space created freely flowing from the outside in –from the inside out– it fuses man with his environment –frees man's mind so he may –if he chooses– live in free association with other men and if receptive, in conscious harmony with the varied moods or nature."<sup>49</sup>

Some architectural elements of Del Carmen Church are vital to understanding Klumb's application of his environmental philosophy: planting areas, the small interior garden, 'permeable' walls, and plenty of fenestrations throughout the building, providing natural

ventilation and lighting to the church's interior.<sup>50</sup> The planter and the long planting areas are elements that bring vegetation to interior spaces, present in many of Klumb's work, such as the Sanctuary of the Blessed San Martín de Porres, the University of Puerto Rico's Law School, and the Student Center, among other buildings. In the Del Carmen Church, a curvilinear design planter marks the small entrance court as a welcoming architectural element. Other planters in the original design surrounded the terra cotta hollow block screen walls in the back patio, which unfortunately no longer exist. The interior garden is another important element present in many of Klumb's designs, both in residential and institutional public spaces. These two architectural design elements provided privacy and a soft transition between the interior and exterior, along with the use of 'permeable walls.'<sup>51</sup> At San Martín de Porres Sanctuary, Klumb designed open fenestrations that blended the interior and exterior. In Del Carmen Church, he used a discrete approach to isolate the grand worship space: a continued curvilinear entrance almost without openings, in essence resembling the Spanish colonial fortifications at the other side of the bay; and ample open interior space (nave) with discrete openings surrounded by 'permeable' terra cotta hollow block walls.<sup>52</sup> These last elements allow successful passive ventilation and natural illumination, a distinctive feature of Klumb's approach and design concepts toward a sensitive connection to the environment following the principles of Wright's organic architecture philosophy. Klumb's proposals became radical since most traditional churches, doors, and windows provided the sole relationship with an outside environment, a method to segregate the sacred interiors spaces from the exteriors.<sup>53</sup>



*Figs. 2.38 & 2.39 – Terra cotta hollow block wall on the southeast side of the church, which allows a passive ventilation system and an interior-exterior connection (top photo). The entrance planter on the northwest side of the church (bottom photo). Photos by Javier Freytes, December 2019.*



Henry Klumb's interest in craftsmanship and a sensibility towards all aspects of comfort in the built environment led him to design furniture for most of his signature projects. His passion for furniture started in the 1930s when he designed a collection of Native-American-inspired furnishings for the New Deal's Native American Arts and Crafts Board with locally available materials.<sup>54</sup> Later, in 1944 in association with Stephen Arneson, he founded ARKLU (ARneson & KLUMB), a furniture factory in Puerto Rico, with almost exclusive use of local materials such as Puerto Rican woods, leather, and ropes in

his simple but elegant designs.<sup>55</sup> Local and international journals and magazines and an exhibition at the Museum of Modern Art featured ARKLU furniture. In 1947 Klumb offered David H. Humphrey, an industrial designer who graduated from the University of Chicago, to lead the factory, which quickly incorporated some of Humphrey's designs.<sup>56</sup> The factory's success only lasted for four years since both founders decided to close in 1948 due to a lack of materials/supplies for such high demand. Despite ARKLU's closing, Klumb continued to design furniture for some of his most cherished projects, Del Carmen Church being one of them. Using almost the same design from San Martín de Porres Sanctuary, Klumb carefully designed the pews surrounding the central altar on the hexagonal-plan nave with local Puerto Rican mahogany.<sup>57</sup>



Fig. 2.40 – The original mahogany pews in the Del Carmen Church. Fortunately, even though the central altar is no longer present, most of these benches still exist, remain in good condition and they are used weekly during the religious services. These pews were manufactured in Comerío, PR. Photo by Javier Freytes, December 2019.

Still, the most crucial element for the Parroquia Nuestra Señora del Carmen is Klumb's use of reinforced concrete as a structural and aesthetic medium. Klumb knew how materials, including finishes, played a key role in physically conveying the ideas and

principles of Organic Architecture, something he learned since his Taliesin days. Inspired by Le Corbusier's works, he incorporated three cement and reinforced concrete technologies (precast, poured-in-place, and concrete block), showing his mastery of these techniques. All this in a context where Portland Cement and concrete established themselves as *the* building materials for a new 'Puerto Rico.' After WWII, architects, inspired by Le Corbusier, started to incorporate exterior rough concrete surfaces in their designs for aesthetic purposes.<sup>58</sup> Influenced by the French architect and his counterparts in Brazil and Venezuela, Klumb managed to achieve the plasticity of Portland cement and concrete technologies in his projects beautifully. It is likely that some elements such as the curved roof eaves along the north façade of his Del Carmen's Church resemble Le Corbusier's Church of Notre Dame-du-haut, Ronchamp (1954).<sup>59</sup> Emulating Le Corbusier's Ronchamp, Klumb left behind traditional rectilinear planes and opted for a plastic, continuity accentuated by its emphasis on exposed finishes. Klumb beautifully exhibits his mastery of concrete and stuccoed textures as an architectural expression when these plastic-curved-flow walls on the north elevations coalesce with the dome, creating a somewhat single element. These continuous plastic expressions accentuate the sense of enclosure on the interior spaces of the Church. Like Ronchamp, rough exterior surfaces weathering patterns are a distinctive feature of Del Carmen Church, which aids the exteriors' perception as a "simple continuous experience of one surface" since the stucco unite the different concrete systems under a continuously exposed cement skin.<sup>60</sup>

The use of concrete block as a plastic medium on its north façade in a remarkable sculptural way fools anyone who assumes they are cast-in-place elements. Klumb's use of precast elements such as the louvered precast panels on the north façade's wall-fence can be seen on diverse projects, including some of his pharmaceutical companies' buildings. Still, Klumb's mastery of Portland Cement and concrete decorative elements in his designs, both in walls and floors, remains an essential understudied aspect of his work.



The use of colored cement for floors is a character-defining feature present in many of his buildings at the University of Puerto Rico and his churches, including the San Martín de Porres, Del Carmen Church, and San Ignacio Church. Additionally, his use of cement stucco/plaster to cover both interior and exterior wall surfaces is a critical defining feature in the Parroquia Nuestra Señora del Carmen. In a rare move, Klumb originally left the stucco unfinished and exposed to the weather. It is in this project alone that he deviated from his usual painted exteriors, a subject to be treated in more detail in the next chapter.



*Fig. 2.41 & 2.42* – Photo of the Notre Dame-du-haut Church at Ronchamp built in 1954 by Le Corbusier, found in Klumb's records (top). Del Carmen Church in 1965, photo by Conrad Elger & Alexander Georges (bottom). Source: AACUPR – Henry Klumb Collection.



Fig. 2.43 – Photo of a Stuccoed Wall at the Notre Dame-du-haut Church at Ronchamp. Photo by Lucien Herve. Source: *Manual of Lathering and Plastering* by John R. Diehl, 1960.

## Endnotes

<sup>1</sup>Luz Marie Rodríguez, “Sanctuary of Blessed Martín de Porres” National Register of Historic Places Registration Form (San Juan, PR: November 11<sup>th</sup>, 2017), 22.

<sup>2</sup> In his autobiography, Wright, refers to Klumb as “my right arm”. Quoted from Rodríguez, “Sanctuary of Blessed Martín...,” 30.

<sup>3</sup> *Ibid.*, 32.

<sup>4</sup> In his essay *Wright, the Man* from July 1974, Klumb narrates his experience leaning about Organic Architecture with Wright in San Marcos in the dessert, developing a small structure: After a couple of weeks of being subjected to this most basic lesson implied in his concept of organic architecture, work began on San Marcos in the Dessert: “We worked under the diffused light of white canvas during the day, at night under gasoline pressure lanterns suspended from the rafters until an electric generator was installed (rattle snakes and sidewinders stayed outside the compound thanks to the wooden fence enclosing it; within the compound by scorpions, enormous spiders, other insects and strange desert creatures, most harmless, some poisonous, congregating by the hundreds on screens placed to keep them off the drafting boards: this nightly assembly Frank Lloyd Wright introduced us to, called it the exuberance of desert life) and his ideas for the dessert resort hotel, grew, unfolded and were put on paper. By the end of May the work was done, the projected building ready for construction. In actually living and doing organic architecture I had found, as a 24-year-old, a deeper meaning than that contained in intellectually conceived formulas, imposing frozen solutions without concern to emotional needs of living beings. Here I experienced how Frank Lloyd Wright achieved an architectural and structural unity by devising a simple standardized part made of the site, by hand, of simple easily available materials, in its basic concept also adaptable to future machine tool application. The structural concept was a double shell of concrete blocks to form a hollow wall, the periphery of the blocks forming a thickened and cored rib to be filled with a concrete mix after vertical and horizontal steel reinforcement bars were placed. The inner and outer shells held in place by tie rods to become a monolithic structure achieved without forms or falsework, woven of standard concrete units, needing no finish inside or out after being placed. Floor and ceilings were formed of single blocks braced until integrally anchored to a structural slab. Needed concentrated structural elements were produced by special reinforcing and filling with concrete hollows between the shells. The size of blocks determined to retain a human scale, the weight by the need of easy handling. Shapes and textures either plain or ornamented to lighten, perforated to give light or ventilation, all depending on the

---

function each part was to serve, on the requirements of spatial needs, intents and interrelations; architectural forms, texture and color on the merging with the spirit of the chosen natural setting and not least on the creator's indulgence in his personal poetic playfulness." Henry Klumb, "Wright, the Man" July 1974, Box 83.22, AACUPR. Also, this essay was published in Frederick Gutheim, *In the Cause of Architecture Frank Lloyd Wright: Wright's Historic Essays for Architectural Record 1908-1952, with a Symposium on Wright and Architecture* (New York: The Architectural Record, 1974) 12-15.

<sup>5</sup>There, Klumb had his first significant experience in design for public service, resulting in 50 housing units for private ownership for the Greenbelt Homeowner's Cooperative. He understood that, the Greenbelt town projects involving housing cooperatives would provide benefits for lower- and middle-income classes, allowing architects to lead and educate potential "future homeowners of moderate income." *Ibid.*, 33.

<sup>6</sup>Architectural historian Gwendolyn Wright points out that Tugwell and Klumb probably knew each other since, Tugwell created the Resettlement Administration, which included the Greenbelt Towns, a project in which Klumb worked as designer in Cooperative Planners based in Washington, D.C. See Gwendolyn Wright, Introduction to *Klumb: Una arquitectura de impronta social/An Architecture of Social Concern*, ed. Enrique Vivoni Farage (San Juan, PR: Editorial UPR, 2006), ix.

<sup>7</sup> Klumb was a critic specifically of the Suburbanization housing projects developed by Leonard Long and other private developers, noting that those residential developments created "homogeneous houses without identity, isolated from the urban centers and lacking a community core." See Vivoni Farage, ed., *Klumb: Una arquitectura*, 26. Also, Efraín Pérez Chanis in 1976 mentions how Klumb served as a mentor for a whole generation of local architects. See Efraín Pérez Chanis, "Arquitectura: Génesis y ruta de la arquitectura en Puerto Rico" in *La Gran Enciclopedia de Puerto Rico 9: Arquitectura/Leyes*, ed. Vicente Báez (San Juan, PR: Puerto Rico en la Mano & La Gran Enciclopedia de Puerto Rico, Inc., 1976), 97-99.

<sup>8</sup> The San Martín de Porres Chapel was featured in several magazine, journals and books, as well in the MoMA exhibition of 1945 curated by Henry Russell Hitchcock. Even though other projects such as Del Carmen Church were also widely featured, none received so much attention and praised as the San Martín de Porres Chapel. <sup>9</sup> *Ibid.*

<sup>10</sup>Rosa Otero, "Permeable Walls and Place Recognition in Henry Klumb's Architecture of Social Concern" (Ph.D. Diss., University of Pennsylvania, 2005), 225.

<sup>11</sup> Henry Russell Hitchcock, *Latin American Architecture since 1945* (New York: The Museum of Modern Art, 1955), 57.

<sup>12</sup> Héctor Balvanera Alfaro, "Arquitectura Religiosa de las Parroquias de la Arquidiócesis de San Juan de Puerto Rico, 1965-1995" (Master's thesis, Universidad Popular Autónoma del Estado de Puebla, 2019), 44.

<sup>13</sup> Del Carmen Church Project description, Henry Klumb Collection, Archivo de Arquitectura y Construcción de la Universidad de Puerto Rico (AACUPR).

<sup>14</sup> The Archdiocese of San Juan Bautista (in Latin: S. Ioannis Portoricensis) was the first archdiocese (originally known as Archdiocese of Puerto Rico until 1924) founded in Puerto Rico in 1511. It oversees 143 Parish churches on the northeast zone of Puerto Rico (Bayamón, Carolina, Cataño, Dorado, Guaynabo, Toa Baja, Toa Alta, Trujillo Alto & San Juan), and its Episcopal see is located on San Juan, the Capital city. See Arnaldo Gierbolini Rodríguez, "Resumen de la Historia de la Iglesia en Puerto Rico y esbozo de las historias diocesanas" (Paper presented at the Primer Encuentro de la Asamblea Nacional de Pastoral in Casa Manresa, Aibonito, PR, June 4-6, 2011), 4; & Balvanera Alfaro, "Arquitectura Religiosa," 41.

<sup>15</sup>J. Borroto Cáceres, "*La Plaza del Recreo Nuestra Señora del Carmen y el trazado de las Calles de Cataño*," (Essay, Archivo Parroquial, Parroquia Nuestra Señora del Carmen, 2013).

<sup>16</sup> Lic. Agustín Pérez Rodríguez, in an interview mentioned that the construction of the old Del Carmen Church in the 1900s "Para construir la vieja iglesia Del Carmen, las muchachas con sus guantes puestos...pasaban la carga de piedras hacia las carretillas y los muchachos las llevaban hasta el lugar donde se iba construyendo la iglesia / To build the old Del Carmen church, the girls, with their gloves on, passed the load of stones to the wheelbarrows and the boys took them to the place where the church was being built." See Colondres, J. "Las dos Caras de mi Pueblo". Del Carmen Church Parrochial Archives. Translated by the Author

<sup>17</sup> After the Spanish American War of 1898, American bishops took charge of the local Catholic church. Friar Mario Rodríguez de León, O.P., Historian mentions that conversations to help settle the Dutch Dominican Fathers with Bishop Blenk in Puerto Rico started in 1903. Friars Gregorio Vuylstek, Martín Luyckx and Joaquín Selbach emigrated from Curaçao to Puerto Rico. As part of the agreement, Bishop Blenk passed in perpetuity the Parish churches of Yauco, Bayamón, Cataño, Palo Seco and Isabela to the Dominican Order. At the same time, new religious congregations from Europe, Spain and the U.S. arrived at Puerto Rico. Throughout the 20<sup>th</sup>

---

Century, the Dominican Order built churches, chapels, religious private schools and the Universidad Central de Bayamón in 1961. See Fray Mario Rodríguez León, "Historia de los frailes dominicos en Puerto Rico: 1509-2009," PReb (blog), 2009, <https://www.preb.com/devisita/domenpr.htm> & Balvanera Alfaro, "Arquitectura Religiosa," 45.

<sup>18</sup> In his book *Fundación del Pueblo de Cataño: Documentos y Comentarios* (1946) Historian Generoso Morales Muñoz presents a complete analysis of enabling legislation for the establishment of Cataño as an independent municipality from Bayamón. Morales points out how wealthy and influential groups under the name of "Comité Pro-Segregación de Cataño" allied with the Political Faction of the Alianza Puertorriqueña in the Insular Legislature against the Municipal Administration of Bayamón who was run by Enrique Ponsa Parés, Esq., a 'Republicano Puro'/Pure Republican of the opposite political faction. The enabling legislation enacted by the Legislative Assembly even allowed influential groups to retain political control of the Town after the 1928 election. See G.E. Morales Muñoz, *Fundación del Pueblo de Cataño: Documentos y Comentarios* (San Juan, PR: Talleres Gráficos de la Imprenta Venezuela, 1946), 192-202

<sup>19</sup> A *Special Report on Municipalities of Puerto Rico* (1964) that included Cataño, mentions that "[In]Cataño... Manufacturing activities of the municipality are related to 32 enterprises of many types and sizes [...] The major part of the manufacturing operations are carried on by plants promoted by the Puerto Rico Industrial Development Company. These plants produce batteries, cast iron soil pipes and fittings, perfumes, soaps, food and kindred products, rum, elastic yarn, and concrete reinforcing rods. Bacardi rum is probably the most widely known product manufactured in Cataño. The municipality is surrounded by major manufacturing operations located in the outer areas of adjacent municipalities. These include Caribbean Oil Refinery, the flour and feed mills of Molinos de Puerto Rico, the Old San Juan Distilling Company, a subsidiary of Schenley Industries, Inc., and plants producing glass, cement, paper, and electric products." Commonwealth of Puerto Rico, *A Report on Municipalities of Puerto Rico: Cataño, Dorado, Toa Baja, Utuado, Vega Baja* (Commonwealth of Puerto Rico, Government Development Bank for Puerto Rico, May 1964), 10.

<sup>20</sup>In December 1955 A. Komendant received a letter from Klumb paying final dues and thanking for collaboration in a non-identified project. The project was identified as the Office Building for Dr. Mario Julia after revising the Komendant Collection list of projects and correspondence at the University of Pennsylvania Architectural Archives.

<sup>21</sup>Developed in Germany since the 1930s, it was until World War II that reinforced concrete shell construction was recognized in the U.S. and quickly became a trend in the late 1950s and early 1960s. See Portland Cement Association, *Cement and Concrete, Reference Book 1956-1957* (Chicago, IL: Portland Cement Association, 1957), 82.

<sup>22</sup> Auguste Komendant, "Possibilities," *Progressive Architecture* 41, no. 10 (October 1960), 182-183.

<sup>23</sup> "Parish Church on a Caribbean Plaza: Del Carmen Church, Cataño, Puerto Rico: Henry Klumb, Architect," *Progressive Architecture* 44, no. 11 (1963), 141.

<sup>24</sup> In a telephone conversation with Richard H. Klumb, son of Henry Klumb, on February 3rd, 2020, he mentioned that Komendant was more interested in innovative concrete technologies. After the shift to traditional cast-in-place methods for the church, Komendant left the project. This statement from Mr. Klumb is supported by Komendant's energetic defense on the use of Pre-cast systems in October of 1960. See Auguste Komendant, "Possibilities", 178.

<sup>25</sup>Otero mentions that "The lowest bidder was Carlos Lázaro García, who bid \$93,619.54 or \$13.37 per square foot. The actual cost of the whole project was \$106,374.00 or \$15.19 per square foot, plus the cost of the Sound System (\$1,496.72), pews (\$4,505), altars (\$1,600), bells (\$3,078.80), and piling (\$7,399.50)." See Otero, "Permeable Walls..." , 261. Also, Henry Klumb Collection, AACUPR

<sup>26</sup> Henry Klumb Collection, AACUPR

<sup>27</sup> Ibid.

<sup>28</sup> The Study was developed by Dario Hernandez, Vice President of BHM. See *Report on Soil Exploration for Del Carmen Church – Cataño, Puerto Rico* (San Juan, PR: Puerto Rico Testing Services, Inc-Consulting Engineers, March 16<sup>th</sup>, 1960). Henry Klumb Collection, AACUPR.

<sup>29</sup>Specifications for concrete block walls mention that these should be load-bearing and non-bearing. Load-bearing blocks are specified as 600 lbs per square inch/individual unit, while non-bearing should be 300 lbs per square inch. Concrete masonry walls have a vertical steel reinforcement system in place on every other course. The cast-in-place ending finish detail ranged from 8", 3", and 12" among the walls, and was separated with a metal lath from the concrete block. The intention of this architectural feature was to give the illusion of a cast-in-place curved form continuous wall. Ibid.

---

<sup>30</sup> The Chapel can host up to 50 people and was designed for daily masses. See Aida Zorrilla, “Constuyen en Cataño Primera Iglesia en Forma Hexagonal” *El Mundo*, May 26th, 1962, S-3.

<sup>31</sup> These pre-cast concrete grilles are made of vertical louver units of each panel approximately 6 ft wide every panel with 3” wide louvers.

<sup>32</sup> The Bell tower is made of concrete posts 12 inches by 18 inches with twelve vertical steel reinforcement bars #5 each. The same system is used at the top of the tower with radial sloping members 12” wide and variations of length from 1 ft to 1 ft -6”. A circular reinforced concrete ring supports a 6” diameter welded steel pipe that give support to the three bells. 2 ½” size diameter galvanized steel pipes form the cross at the upper part of the church. Aida Zorrilla on an article published in *El Mundo* on May 26<sup>th</sup>, 1962 tells the story behind the bells: “Las campanas fueron donadas por las tres congregaciones de la parroquia. Los tonos combinados de las tres forman el principio del ‘Te Deum’, la canción en acción de gracia en honor de la Santísima Trinidad. La primera de las campanas, donada por las Hijas de María, pesa 265 libras y lleva la inscripción bíblica ‘Es la voz del Amado que llama’. La donada por la Sociedad del Santo Nombre pesa 365 libras y en ella está inscrito ‘Si oiréis mi vox, no endurezáis vuestro corazón’. Esta campana tocará los domingos para recordar a los fieles su obligación de oír la misa dominical. La última de las campanas, y la más pesada, 640 libras, fue donada por la Congregación del Sagrado Corazón. Con ella se darán dobles y es por eso que lleva el texto bíblico que lee ‘Oí una voz del cielo que decía bienaventurados los que se mueren en el Señor.’” / “The bells were donated by the three congregations of the Church. The combined tones of these three forms the beginning of the ‘Te Deum’, the song in action of grace in honor of the Holy Trinity. The first bell, donated by the Daughters of Mary, weighs 265 pounds and bears the biblical inscription ‘It is the voice of the Beloved who calls.’ The one donated by the Holy Name Society weighs 365 pounds and is inscribed on it ‘If you hear my voice, do not harden your heart.’ This bell will ring on Sundays to remind the faithful of their obligation to hear Sunday mass. The last bell, and the heaviest, 640 pounds, was donated by the Congregation of the Sacred Heart. This [bell] will give doubles that is why she carries the biblical text that reads ‘I heard a voice from heaven saying blessed are those who die in the Lord.’” See Zorrilla, “Construyen en Cataño...” Translation by the Author.

<sup>33</sup> The plastic dome skylights are pre-assembled units of translucent plexiglass. The complete installation procedures can be found on the 1961 Construction specifications. Henry Klumb Collection, AACUPR

<sup>34</sup> The terra cotta masonry walls are 8 ft tall screens covering the ground floor walls of the west, south and east sides of the hexagonal shaped floor plan. These 4 walls were designed with a red clay tile block and filled with cement mortar and horizontal steel 1 # 3 rebars. Each block is a nominal have 6” x 12” x 6”, non-load bearing ‘tiles’ manufactured according ASTM C56-57. The mortar formulation can be found in the 1961 construction specifications. Henry Klumb Collection, AACUPR.

<sup>35</sup> In this era, tilt-wall panels were developed on site (cast-in-place), now a days it is usually prefabricated. See Herb Nordmeyer, *The Stucco Book: The Basics* (Castroville, TX: Nordmeyer LLC, 2012), 59.

<sup>36</sup> In the *Report on Soil Exploration for Del Carmen Church – Cataño, Puerto Rico* by Puerto Rico Testing Services, Inc-Consulting Engineers from March 16<sup>th</sup>, 1960, three test borings were made in the site. The study reveals that ‘Subsoil conditions are typical sand-covered lagoonal deposit. The 1<sup>st</sup> layer or top layer of soil found gray sand in a medium dense state of density except for its uppermost 1.5 ft to 4 ft which contain some organic silt and is very loose. The 2<sup>nd</sup> layer from 10 ft to 12.5 ft found organic clayey silt and organic sandy silt which extends to a depth of 22.5 ft to 26 ft. Boring No. 3 found occasional coral rock fragments. They also found a very stiff, silty clay formation extending to the bottom of the borings. Near the bottom of the borings they also discovered limestone rock fragments. Lastly, the report mentions the identification of water table located at a depth of 2.5’ beneath the ground surface. Hernandez’s recommendations for piling were adopted in the 1961 construction specifications as follows: for pre-cast piles-14 ft x 14 fsize, 35ft below grade; poured in place piles – 8 ½” with a minimum of 45 ft below existing grade. Both systems needed 30 piles in total. If 20 piles were selected under the main structural columns, these should extend additional 5 ft. Henry Klumb Collection, AACUPR

<sup>37</sup> Enrique Vivoni Farage, “La Arquitectura del movimiento moderno en Puerto Rico: La obra de Toro y Ferrer y Henry Klumb”, Editorial Online (July 2012): 19. Translated by the Author.

<sup>38</sup> Otero mentions that “Klumb first encountered ideas of liturgical renewal during the 1920s with several circular and centralized churches were built in Europe before 1914, which Klumb may have visited”. The Author noted this on the archival research at AACUPR. Some of the churches in Klumb’s Collection are: the Church at Wahrung by Otto Wagner, Church of the Sanatorium at Stein in Vienna, Church of St. Rupert in Munish by Gabriel von Seidi in Munish; Church of St. John at Manheim by Curjel and Moser; Church of St. Mary in Spanday by Christoph Hehl, and a church by Auguslin Pacher in Munich. Also, Otero points out that there were

---

conversations about demolishing the Church since 1953, but Father Félix Struik, O.P., mentions that the Dominican Order was considering the construction of new building since the 1940s. These conversations probably started as numerous repairs were done to the previous original church as a consequence of the different hurricanes of the first half of the 20<sup>th</sup> Century in Puerto Rico. See Otero, "Permeable Walls," 262 & 59; and Félix Struik, O.P. "Centenario de la Parroquia del Carmen de Cataño 1893-1993" (unpublished manuscript, Archivo Parroquial, Parroquia Nuestra Señora del Carmen, 1993).

<sup>39</sup> In her analysis, Rosa Otero points out the demolition trend of parish churches in Puerto Rico from the 1900s through the 1970s. She mentions that Marvel & Moreno's book presented over 15 demolished town parish churches in this period that eventually were replaced with modern church buildings. Otero, "Permeable Walls," 245.

<sup>40</sup> In my continued research from historic photos of the church on different social media groups, some citizens have expressed their disagreement with Klumb's 1962 design, often naming it as the 'imposter' church and claiming the destruction of the original 1905 building as a loss of Cataño's built heritage. See also, Otero, "Permeable Walls," 266.

<sup>41</sup> Even though Jorge Rigau mentions the church as an 'early example of *béton brut* use', the concept was established by Le Corbusier in the 1950s in reference of exposed rough concrete finishes like wood board patterns and exposed aggregate on concrete. See Jorge Rigau, "Architecture of the 1960s in Puerto Rico, 1958-1972", National Register of Historic Places Multiple Property Documentation Form (San Juan, PR: Jorge Rigau Architectos PSC, July 3<sup>rd</sup>, 2019), 61, & Kiran Joshi, Ed., *Corbusier's Concrete: Challenges of Conserving Modern Heritage-Proceedings of Seminar on Conservation of Le Corbusier's Work in Concrete, Chandigarh*, 11-13 February 2002 (Chandigarh, India: Chandigarh Perspectives/Chandigarh College of Architecture, 2005), 40.

<sup>42</sup> Dr. Luz Marie Rodríguez agrees with Levine's analysis of how Klumb used this resource for the spatial configuration of the Sanctuary of Blessed San Martín de Porres in 1946 and at the Master Plan for the University of Puerto Rico, Río Piedras at an urban scale. See Rodríguez, "Sanctuary of Blessed", 9; and Luz Marie Rodríguez, "Klumbumbus descubre el Trópico: Henry Klumb, Puerto Rico y la arquitectura de lo existente" *Arquitextos* 120, Year 10 (May 2010), <https://72.10.48.168/revistas/read/arquitextos/10.120/3415>.

<sup>43</sup> International architects such as Buckminster Fuller with the Dynaxion House and Tower (1946) leading the trend. Also, Rigau makes an analysis on the use of hexagon shape structurally, spatially, and ornamentally by local Puerto Rican architects. Some projects include El Monte Sur by Edward Larabee Barnes Condominio Costa Azul by Amaral & Morales; the Tower of the Mayaguez Medical Center by Pedro Luis Amador; the public urban arrangement of the Condominio Quintana in Hato Rey by Reed, Basora & Menéndez; the Río Piedras' Market by Pedro Mirando & Associates; the Bayamon's Instituto Pedagógico (previously known as The John F. Kennedy Day Care Center in 1967) by George Z. Mark & Rafael Pérez Marchand; the Del Carmen Church by Henry Klumb; the Miramar Charter House Hotel by Angel Avilés; the Ponce Art Museum by Edward Durrell Stone; a low-income housing development in Yauco by George Z. Mark; the Sheraton Hotel in Condado by Toro y Ferrer and the Residence for Antonio Caldas in Río Piedras by Samuel G. Marra. See Rigau, "Architecture of the 1960s," 66-58.

<sup>44</sup> See Otero, "Permeable Walls," 246.

<sup>45</sup> After an extensive revision of Klumb's collection in AACUPR, no periodicals or journals featuring Latin American religious architecture were found, only magazines, journals, and a book featuring projects from the United States and Germany.

<sup>46</sup> Henry Klumb Collection, AACUPR.

<sup>47</sup> See Henry Klumb, "Life Core" (1944). Henry Klumb Collection, Box 84.11, AACUPR.

<sup>48</sup> Rodríguez, "Sanctuary of Blessed", 22.

<sup>49</sup> Henry Klumb, "My Architectural Design Philosophy", Celebration of Architecture Florida Design '79 - 65th Annual FAIA Convention (October 2, 1979) Henry Klumb Collection, AACUPR

<sup>50</sup> Dr. Rosa Otero defines 'Permeable walls' as a "...screened border that opens a space to ventilation, illumination, views, and one's social life; in other words is a bidirectional porous element that is deliberately controlled and permits the entrance and/or exit of various permeatees (light, breezes, physical human access). Permeable walls perform different purposes depending on their location, material, program, and expression. ...Permeable walls act as mediators for the dialogue between the building's interior and exterior, which can be manifested by a wide range of formal manipulations, including opening to a landscape, framing a specific scene, or simply negating the relation. Permeable walls...are also active participants in the regulation of two interior spaces. The degrees of a wall permeability can be classified according to the permeatees, the physical elements

---

penetrating its fabric. In short, the ways in which people, light, and air are able to permeate a building are determined by the permeability of its walls.” For a full discussion see Otero, “Permeable Walls,” 123-125.

<sup>51</sup> Ibid.

<sup>52</sup> Otero, “Permeable Walls,” 265.

<sup>53</sup> Balvanera Alfaro, “Arquitectura Religiosa,” 250.

<sup>54</sup> Enrique Vivoni Farage, “Henry Klumb y la Exuberancia poética en la Arquitectura/Henry Klumb and Poetic Exuberance in Architecture” in *Klumb: Una arquitectura de impronta social/An Architecture of Social Concern* (San Juan, PR: Editorial UPR, 2006), 31.

<sup>55</sup> Ibid.

<sup>56</sup> See Lelis Marqués, “Cuando nació el Caribe Hilton; notas sobre el Diseño Industrial en Puerto Rico”, *Entorno 7: Colegio de Arquitectos de Arquitectos y Arquitectos Paisajistas de Puerto Rico* (2007): 13.

<sup>57</sup> The pews were designed to sit 525 people and were manufactured in Comerío, P.R. See Zorrilla, “Construyen en Cataño...”

<sup>58</sup> Hubert-Jan Henket, “Opening” in Wessel de Jonge & Arjan Doolar, eds. *The Fair Face of Concrete: Conservation and Repair of Exposed Concrete: Proceedings International DOCOMOMO Seminar*. (Eindhoven, Netherlands: Eindhoven University of Technology Printshop, 1998), 11.

<sup>59</sup> Henry Klumb Collection, AACUPR.

<sup>60</sup> In his illustrated essay “Plaster in Architecture,” architectural historian Charles W. Moore presents a meticulous analysis of how stucco and plasticity has shaped architecture along history and includes an analysis of Le Corbusier’s Ronchamp church. See Charles W. Moore, “Plaster in Architecture” in John R. Diehl, *Manual of Lathing and Plastering*, Gypsum Assoc. Ed., (New York, NY: National Bureau of Lathing and Plastering, 1965), 4-30.



## CHAPTER 3

### **Portland Cement Stucco and Pneumatically Applied Mortar-Shotcrete Technologies: Characterization, History and Twentieth-Century Evolution**

"The great fault of stucco as now used is that it is not what it proclaims itself to be. It is an imitation, a makeshift. The designs of the vast majority or more properly monolithic construction. Undoubtedly this apparent massiveness and appearance of permanence accounts in a large degree for the enthusiastic reception of the material by the public..."

"Stucco is not a structural material; it is only a finish-the skin which clothes the structural body." - "Popularity of Stucco," *Concrete-Cement Age Journal*, Oct. 1915

Henry Klumb specified Portland cement stucco and plaster for the exterior and interior finishes of almost all his projects. Portland cement stucco work or "empañetado/empañete de cemento" was the norm in Puerto Rico from the beginning of its introduction in the twentieth century.<sup>1</sup> Even though the practice of covering masonry surfaces with lime or gypsum is a long millennia tradition, the rise in the use of Portland cement and reinforced concrete gave a new meaning for this practice. During the nineteenth century, the use of concrete technologies was often applied to engineering and infrastructure works such as roads, ports, and dams. The development of the Portland cement industry in the early twentieth century was vital for acknowledging and seeing the possibilities of concrete as an expressive architectural material. This transition had a tremendous impact on the development, use, and technical application of Portland cement stucco as well.

Lost for centuries, the use and development of hydraulic cement technologies caught the interest and the imagination of engineers beginning with the ongoing experiments by John Smeaton to produce natural hydraulic cements in 1756 and later in 1824 when Joseph Aspdin patented and promoted an "artificial Portland cement." Europe soon took over the production and exportation of natural and Portland cements; however,

by the end of the early twentieth century, the U.S. was a major producer. As discussed, concrete became a 'wonder' material that was easy and cheap to use, durable, fireproof, and weather and moisture tolerant. As the economy boomed and production increased, the continued use of concrete as a purely engineering material responded to economic considerations, which led to an excuse for poor design and poor appearance and care.<sup>2</sup> In this sense, reinforced concrete was seen as "dull and plain to stand," except in industrial works, it was always covered with different finish materials, including stucco.<sup>3</sup> The technological improvements in the U.S. since the 1890s were crucial to change the prevailing perceptions towards reinforced concrete, as it became a medium of experimentation, especially within its exterior finishes.

Following the trends of the Colonial Revival, some architects in the early 1900s began experimenting with cast stone to imitate traditional ornamentation, something not welcomed in some sectors of the guild until the 1920s.<sup>4</sup> Simultaneously, a wide range of catalogs and journal articles appeared featuring the decorative qualities of concrete, including stucco, exposed aggregates, mosaic, tiles, and other surface finishes. Over the first half of the twentieth century, a wide variety of novelty concrete surface finishes were developed, some becoming long-lived, others experimental. Portland cement stucco as a concrete finish grew in popularity between the 1910s and 1920s, particularly in domestic architecture. Thus, it became the "most widely used material for the decoration of monolithic concrete structures."<sup>5</sup> As modern architects such as Le Corbusier praised concrete and advocated for its simplicity and an honest expression of the material, Portland cement stucco entered its demise in the 1950s as with the rise of brutalist 'fair face concrete' trends through the 1970s.

In *Exposed Concrete Finishes: Finishes to In-Situ Concrete* (1964), J. Gilchrist Wilson classifies two types of concrete finishes: integral and applied finishes.<sup>6</sup> Integral

concrete finishes result from the alteration of the Portland cement mix by adding components to the mix, which results in a consolidated matrix. Some of these include pigments to create a colored cement paste, acid stains, and specific aggregates. An Integral concrete finish, such as exposed aggregate, was fundamental in accepting concrete as an architectural material in the early 1920s.<sup>7</sup> On the other side, Applied concrete finishes, as defined by Wilson, are finishes applied to concrete surfaces that take advantage of the material's "sculptural potential" since they can be applied, creating texture and patterns on the surfaces.<sup>8</sup> From the four general types of applied finishes identified in the book, this investigation focuses on 'solutions or pastes,' which includes stuccos.<sup>9</sup>

### 3.0.1 *Portland cement stucco*

Stucco, which means 'Plaster' in Italian, has a long history of applications in architecture for centuries using different materials such as lime, gypsum, and Portland cement.<sup>10</sup> As a versatile facing material, it has been often used to protect surfaces from the weather, as a decorative medium, or to imitate a traditional building material, which can be plain faced or textured. In the early twentieth century, Portland cement stucco was used as a 'veneer material' and was widely used to conceal unsightly poor workmanship of reinforced concrete structures. Historically, there has been much confusion regarding the terms stucco, plaster, and render since all three terms have been used interchangeably over decades to refer to specific plasterwork and regional variations.<sup>11</sup> The Portland Cement Association defines plaster as a 'material applied on a wall surface in thin layers.' Even though 'plaster' is known as the general term for the application of mortar to wall surfaces, in the U.S., it is commonly used exclusively for interior applications. Since the nineteenth century, in the U.S., the term 'stucco' has been used to denote exterior plastering work in buildings.<sup>12</sup> Render is also specifically used in the United

Kingdom for the exterior application of plaster.<sup>13</sup> For the purposes of this research, the term 'stucco' will be used as defined by the American Society for Testing and Materials in ASTM C926 -Portland Cement-based plaster used on exterior locations.<sup>14</sup>

Traditionally, Portland cement stucco can be applied by hand or machine in a two or three coat layer-process directly to a solid masonry substrate, wood, or metallic lath. This thesis focuses on the application of stucco directly onto masonry surfaces, specifically reinforced concrete. Based on a three-coat stucco hand-application, in the U.S., stucco layers are classified as 'scratch' or 'pricking-up' coat (first and preparatory layer), followed by a 'floating' or 'brown' coat (second coat) and a 'finishing' coat. In Puerto Rico, Portland cement stucco is known as *empañetado* or *empañete*, without much distinction between coats. Still, earlier stucco technologies (mostly lime-based) used the terms *enfoscado* for the scratch coat and *repello* for the brown coat.<sup>15</sup>

### 3.0.2 "Sprayed" Stucco or Pneumatically applied mortar

Despite being invented in 1907, the machine application of stucco is still an understudied topic. Initially recognized as the 'Gunite' technique, it is known today as 'Shotcrete 'or *hormigón/concreto proyectado/lanzado* in Spanish.<sup>16</sup> Shotcrete is defined by the American Concrete Institute (ACI) as the technique in which "concrete or mortar conveyed through a hose and pneumatically projected at high velocity onto a surface to achieve compaction."<sup>17</sup> As a malleable, free form, plastic material with a rough finish, the Shotcrete technique allows the application of stucco on inaccessible areas of buildings for a wide range of decorative purposes, complex shapes, and walls without the requirement of forms.<sup>18</sup> Since its invention in the early 20<sup>th</sup>-century, it quickly became coopted by the engineering field because it made possible the application of concrete on tunnels, domes, tanks, and other civil engineering projects. Nowadays, it is widely recognized as a concrete repair method and not for decorative applications. Shotcrete can be applied in

one or several coats using the dry-mix or wet-mix processes.<sup>19</sup> Shotcrete is recognized by its properties such as low water/cement ratio, high strength with rapid strength gain, high density, low permeability enhanced adhesion-bond strength, and its use of a high volume of material for less.<sup>20</sup> Since the term shotcrete encompasses mortar and concrete, there are several types of shotcretes. For the purposes of this thesis, the 'coating' type of Shotcrete is widely discussed along with the traditional hand applications of stucco.<sup>21</sup>

Because of its low cost, utility, and minimum maintenance needs, stucco has often been seen as a "sacrificial coating," unnoted and deemed an unimportant part of a building, prone to removal, alteration, and destruction.<sup>22</sup> Still, its use in Puerto Rican mid-century modern architecture validates its role as an aesthetic and protective material over concrete and other masonry substrates since it can also aid buildings in resisting extreme tropical events such as Hurricanes.<sup>23</sup> The exterior Portland cement stucco finishes at the Del Carmen Church were applied using both hand and machine-sprayed applications.

### **3.1 Cement finishes in Klumb's designs**

Besides using colored cement floors, terrazzo, and painted surfaces, one of the key elements that helped Klumb master concrete as an expressive architectural material, was his use of Portland cement stucco in different variations. An analysis of construction documents, drawings, and photos of over ten (10) projects designed by Klumb between 1957 and 1967 revealed the use of five (5) prevailing types of Portland cement stucco in his works.<sup>24</sup> These finishes were identified in his works as Waterproof Cement Plaster Finish, Sand Finish Portland Cement Plaster, Rough Cement Plaster Finish, Stippled Portland Cement Plaster, and Cement Plaster. On the exteriors, Klumb usually used textured or a combination of textured and smooth finished stuccoes, while smooth finish stuccoes were typically used on the interiors in his projects.

As a general practice in all Klumb's projects, after a formwork was removed from poured-in-place walls, the surfaces were rubbed with carborundum bricks, using sufficient water to make the surfaces even and smooth. For the bonding of the stucco work, four (4) techniques were commonly used depending on the project: lining forms with reinforcement wire, retarding compounds, which was added to the setting cement mix; mechanical treatments by hacking or chipping the concrete surfaces; or the application of Liquid Bonding Agents to concrete substrates before the application of stucco.<sup>25</sup>

One of the most common finishes specified by Klumb; and included in the construction documents for the exteriors and interiors at the Del Carmen Church was the "Cement Plaster Finish." This type of finish was quick and straightforward, only using 1-part cement, 3-part sands, and ¼ lime with some variations.<sup>26</sup> The finish was usually specified as one (1) 3/8" thick coat over poured-in-place concrete walls and a two-coat job on concrete block masonry walls, with an even smooth texture. The "Cement Plaster Finish" was applied using traditional hand procedures or sprayed/shotcrete machine and then troweled for a uniform thickness.<sup>27</sup> When it was required, additional coats were added up to a 1 ½" thickness. The specifications required the stucco to be floated and darbed with a wood float to produce a compact, dense coat and a smooth finish.

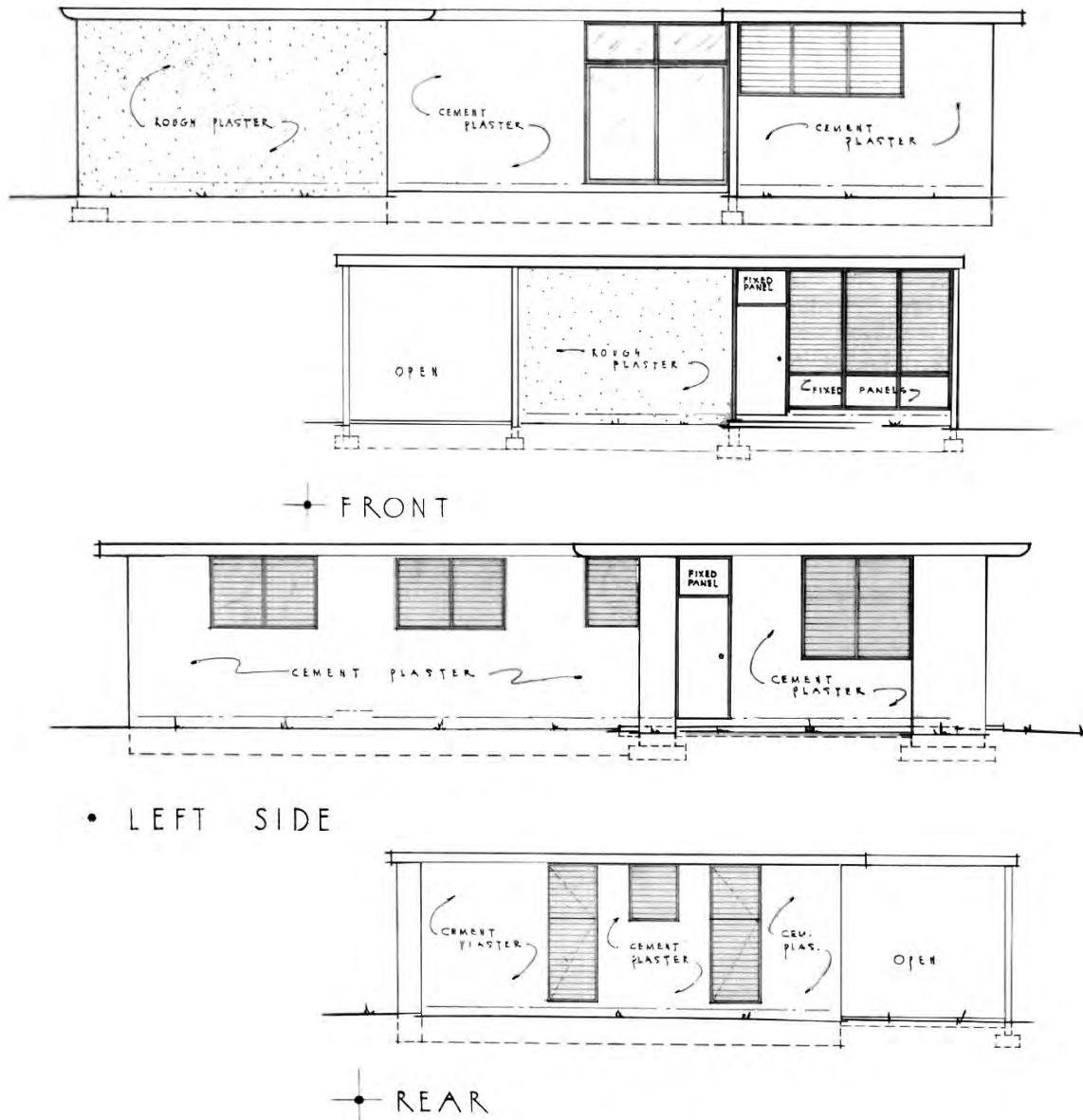


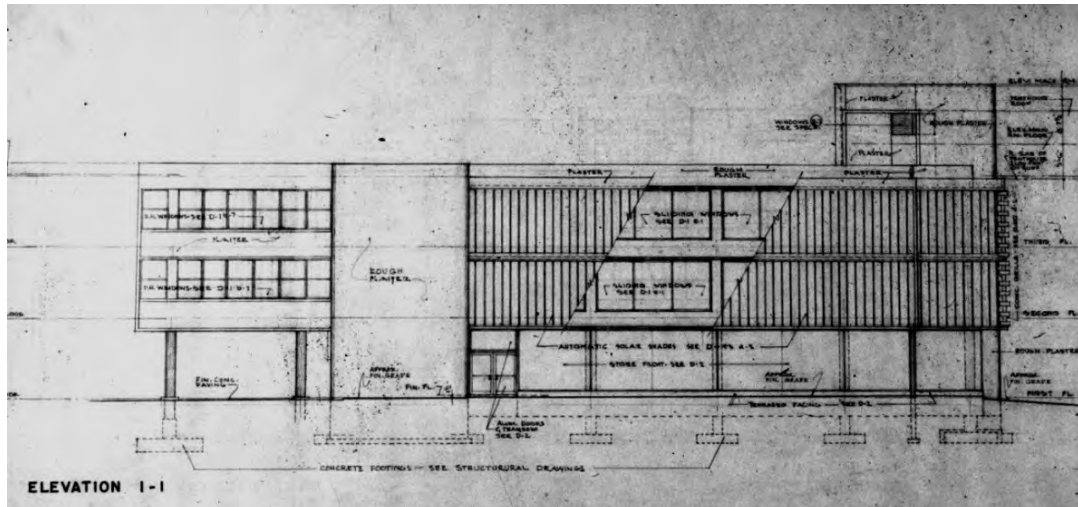
Fig. 3.1 – Drawings of The Cerezal Homes in Río Piedras (1949). Klumb used both smooth and rough variations of stucco, or smooth stuccoes on the exteriors. Source: Henry Klumb Collection – AACUPR.

As a smooth sandy finish, the "Sand Finish Portland Cement Plaster" is usually seen on the interiors of Klumb's projects. This stucco finish consists of traditional scratch, brown, and smooth even finish coats, which can be applied by hand or spray-machine. The mix was usually 1-part Portland cement, 3-parts sand, ¼-part hydrated lime for the scratch and brown coats, while 1-part Portland cement, 2-parts sand by volume, 1-gallon hydrated lime per bag of cement, and water for Finish coats. The scratch coat has a ¼"

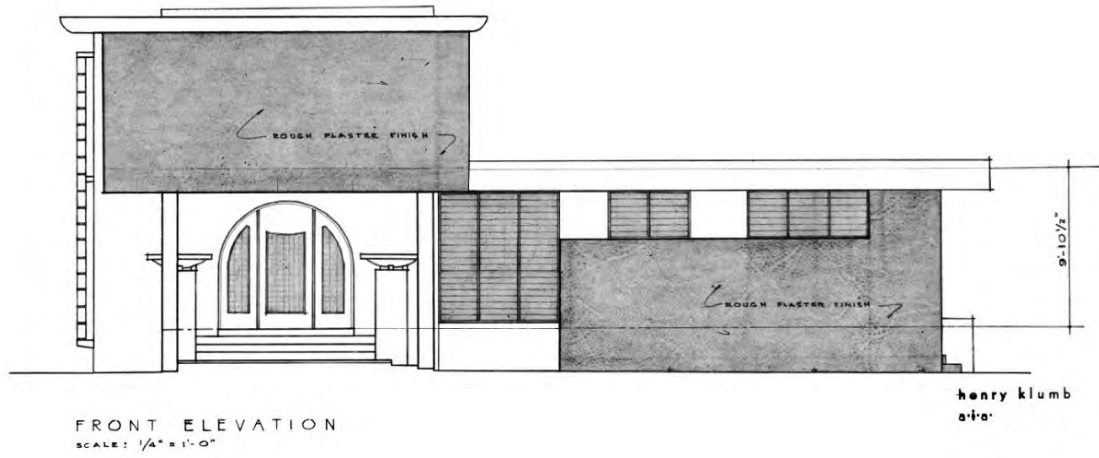
thickness, while the brown coat can have up to 3/8" thickness over poured-in-place or concrete masonry substrates. Specifications require both leveling and floating with a rubber float to "obtain a dense, evenly textured plumb." Other projects mentioned treating curing surface of the brown coat to be finished with a sponge rubber floating operation" along with water spraying and thus leaving the surface with a sandy, evenly textured finish.<sup>28</sup>

The "Rough Cement Plaster Finish" is usually showcased by Klumb on the exterior walls in numerous projects. The Finish consists of applying a stiff mix over a concrete substrate in an irregular pattern by hand, trowel, or a medium stiff bristle brush. Then it was dabbed to ensure good bonding up to a 1 1/2" coat thickness. Then, the mason must strike off high spots by rodding or troweling so that top surfaces can be approximately 3/4" over the base coat. Then the rough surface must be struck off by rodding until the voids have a depth of 5/8". Other projects specify the application of stucco "over thoroughly wetted surfaces in an irregular splattered pattern, using a wide calcimine brush to a depth of 2".<sup>29</sup> The rough finish mix was specified to be the same as the "Cement Plaster Finish" and must be applied only by hand.





*Figs. 3.2 & 3.3 – Elevation & Photo of the IBM Office Building for the San Juan Real Estate Corp., in Santurce (1958). Klumb featured the use of the “Rough Cement Plaster Finish” on the building’s exteriors. Source: Henry Klumb Collection - AACUPR*



*Fig. 3.4* – Elevation of the Bueno House Addition in Punta Las Marías, Santurce (1967). In this addition to an original design by Antonin Nechodoma, Klumb featured the use of the “Rough Cement Plaster Finish” on the building’s exteriors. Source: Henry Klumb Collection - AACUPR

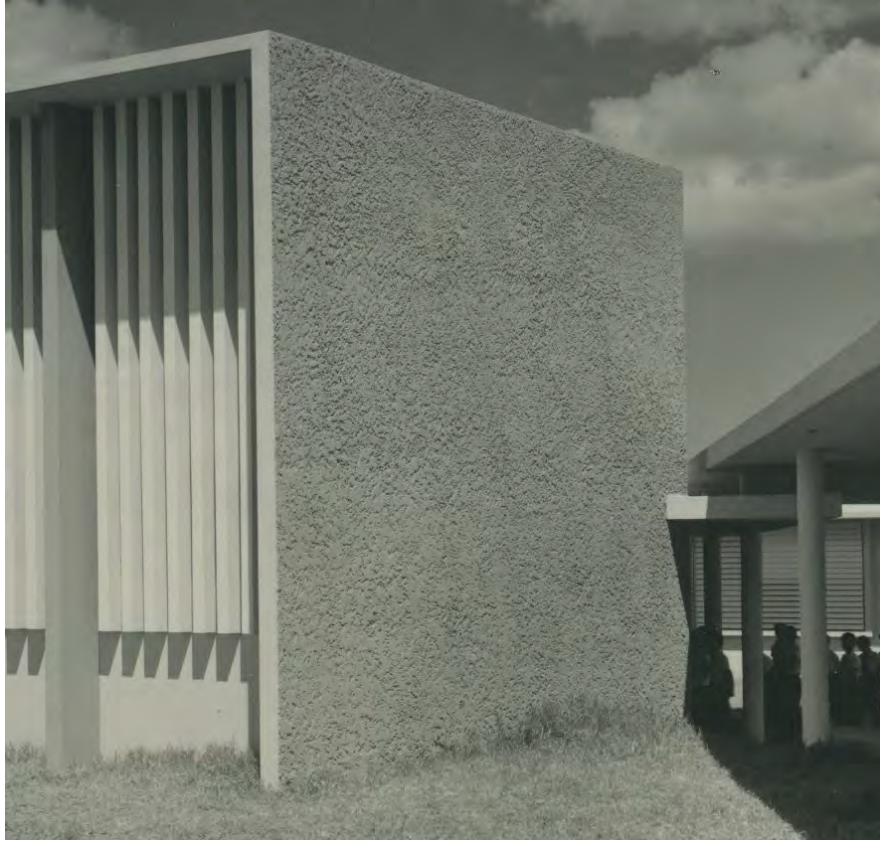


*Fig. 3.5* – The San Martín Office Building & Condominium, Santurce (1957) featured the use of the “Rough Cement Plaster Finish” on the building’s exteriors. Source: Henry Klumb Collection - AACUPR

The "Stippled Cement Plaster Finish" was also commonly seen on exterior architectural elements on Klumb's projects. This unique stucco finish used the same mix proportions as the "Sand Cement Finish Plaster." Its application included that after rodding and partial set of the scratch and brown coats, "surface shall be stippled with a stiff wire brush to produce a finish." At the UPR Law School project, a spray machine was recommended for this specific finish with an average of 1/8" thickness.<sup>30</sup> The "Highlighted stippled cement plaster finish," another particular type of stucco finish was also specified for this project. For the Highlighted stippled finish, a stippled finish must "be troweled to strike off the tops of the stippled texture to produce discontinuous flat surfaces" and therefore producing flat surfaces in a common plane of "approximately 1/8" over the base plaster surface."<sup>31</sup>



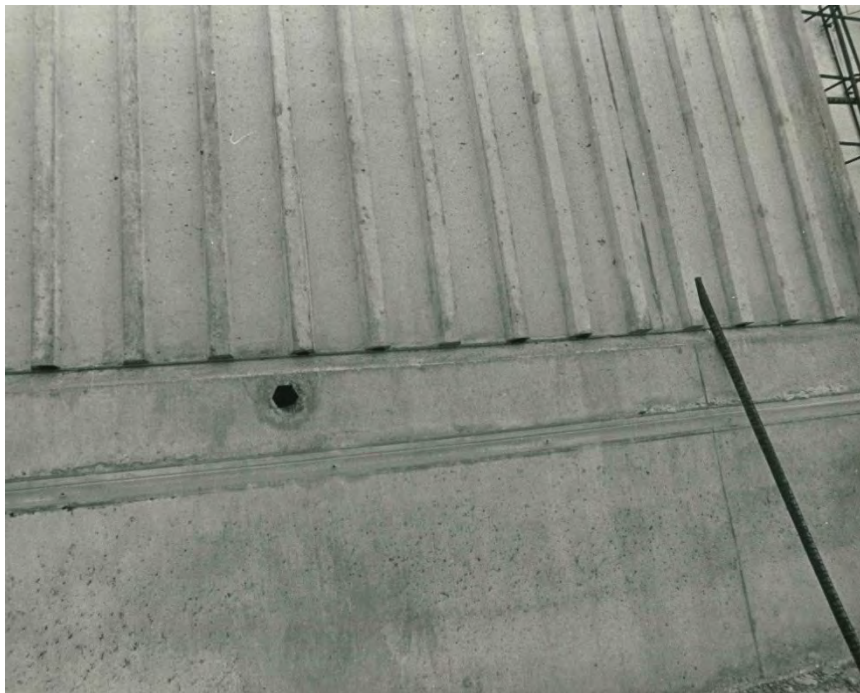
*Fig. 3.6* – Photo of the original "Stippled Cement Plaster Finish" at the entrance of the UPR Museum of History, Anthropology and Art designed by Klumb in 1948. Photo by Author, 2018.



*Figs. 3.7 & 3.8* – The Colegio San Ignacio de Loyola (1952) & Centro de Estudiantes/Student Hall at the University of Puerto Rico, Río Piedras Campus (1958) both features the “Stippled Cement Plaster Finish.”  
Source: Henry Klumb Collection, AACUPR.

The "Waterproof Cement Plaster Finish" is often mentioned in different projects from the era, specifically for roof slabs. This type of finish is characterized by adding a non-shrink "metallic-aggregate material designed to reduce shrinkage and water permeability in concrete."<sup>32</sup> The refined metallic material was usually added along with a fine plasticizing material, a "cement dispersing agent," and an "oxidation catalyst." The metallic aggregate was added in different proportions depending if it was for a "Bonding coat" (like the scratch coat) or a "Plaster coat" (like the brown coat).<sup>33</sup> After mixing the stucco mix with a "mechanical type batch mixer," the bond/scratch coat was applied over concrete substrates, following by a 1 ½" thick coat of plaster/brown coat when the previous bond coat has dried. The Plaster coat was then "compacted and troweled to a smooth finish." After applying the two coats, the surfaces were protected by a damp burlap from the external environment. Even though Del Carmen Church's February 1961 does not mention this type of finish, the forensic investigation findings match these specifications.

Besides using stucco as exterior finishes, the Ciba-Geigy Pharmaceutical Plant in New Jersey from 1984, one of Klumb's final designs, has been documented to date as the only project Klumb used "fair-faced" exposed concrete.



*Figs. 3.9 & 3.10* – The Ciba-Geigy Pharmaceutical Plant in collaboration with engineer A. Komendant, built in 1984 is considered the only project where Klumb used ‘fair-faced’ concrete as an exterior finish. Source: Komendant Collection, University of Pennsylvania Architectural Archives.

### 3.2 Stucco finishes at the Del Carmen Church

In the 1961 Construction documents, Klumb stated that the exterior surfaces of the Del Carmen Church consisted of a "Cement Plaster Finish" and "Waterproof Cement Finish." In the original February 1961 specifications, Klumb outlined the application of traditional troweled stucco finishes, including a 'Plaster Bond finish' which was a requirement to provide bonding for plastering before their application on the wall surfaces:

"Bond may be obtained by lining forms with chicken wire or treatment may be mechanical, such as hacking or chipping, or it may be accomplished by applying cement retarding compound as hereinbefore specified to inside of forms. When the retarding compound is used, and upon removal of forms, all loose surface material shall be removed by wire brushing until a rough bonding surface of exposed aggregate is obtained. Use plaster bond finish for all vertical or overhead concrete surfaces that are to receive an applied finish of mortar or plaster after forms are removed."<sup>34</sup>

The specifications also required that concrete blocks should be wetted before the application of the stucco.

The February 1961 specifications state a two-coat job of 3/8 inch of "Cement Plaster"/Cement Stucco for both poured-in-place concrete and concrete block masonry exteriors and interiors of the church. The specifications outline the use of 1 bag of Cement, 2.7 cubic feet of sand, 0.17 cubic feet of hydrated lime, and water for the cement plaster/stucco mix. The same document specified the following materials for the waterproof cement finish:<sup>35</sup>

" 1-inch-thick waterproof finish plaster for the dome... [the mix uses] Concrete mix, Stearox '100 from Master Builder Company as a water repellent additive, not less than 0.25 lb per bag of Portland Cement following the manufacturer's instructions."<sup>36</sup>

On the other hand, Klumb used a 'spray machine' for the application of exterior stucco. The April 1961 Notice to bidders No. 1 mention the following materials for the application of a Spray applied stucco of a 1/6" to 1/8" thickness:

- White Portland cement
- Lime Type S, similar or equal to Miracle brand lime
- Sand- fine, clear, white silica sand
- Water- clear, fit to drink
- Spray equipment
- Mechanical mixer

After the application of the stuccoed finishes in the wall, the specifications required that these should be "sprayed with clean water during the curing period as frequently as drying conditions may [be] required to keep [the] concrete surface moist." The document also specified that all stucco surfaces "shall be true and even plumb and/or level and free from scratches, ridges, waves, chips, voids, cracks, and other imperfections... Patching shall match existing work in texture and finish and shall finish flush and smooth where it joins previously applied plaster." Lastly, the construction specifications also provided for the protection of the surfaces during curing with coverings such as "burlap or cotton matting"; and after curing with "mats, waterproof paper or prepared roofing."

The February 1961 specifications mention using a 'waterproof cement finish' on the dome and roof slabs. This waterproof finish included a Portland cement mix and a 'Stearox '100 from Master Builder Company' as a water repellent additive for the waterproof cement finish. It is unknown if this specification was followed.

The forensic investigation identified that the finish coat applied for the poured-in-place dome contained ferrous aggregates or filings as an additive. The on-site investigations also confirmed three types of Portland cement stucco finishes on the church's exteriors. A Shotcrete-sprayed stucco on the poured-in-place tilted walls, exterior columns, and the belfry; a troweled applied stucco over the concrete block masonry surfaces, and a troweled applied stucco with iron filings on the dome. The instrumental analysis also found that the mix composition outlined for in the February and April 1961 documents were not followed. These findings are discussed in depth in Chapter 5. The



forensic investigations and archival research point out that Klumb used the general specifications of the "Cement Plaster Finish" and a "Waterproof Cement Plaster Finish" featuring a metallic ferrous aggregate. Some of these incongruencies in the construction documents will be further discussed in Chapter 4.

### 3.2.1 *Materials Characterization*

Portland cement stucco has been characterized as a hard, strong, workable, and fire and weather-resistant material.<sup>37</sup> Its workability has provided for its application on a wide range of flat, curved, and rough surfaces and masonry materials such as brick, stone, hollow clay tiles, reinforced concrete, and woven, welded, or expanded metal lath.<sup>38</sup> The basic material recipe for a proportioned mix of Portland cement stucco includes Portland cement, fine aggregates (sand or crushed stone), hydrated lime, and water. When these materials are mixed, a workable mortar is formed.<sup>39</sup> Additives and admixtures are sometimes added to enhance the mix's performance before or/and after its application. Despite some rare documented cases, Stucco has been traditionally applied in two or three coats, with different thicknesses.<sup>40</sup> The coats are usually known as base coats and a finish coat, which provides the decorative surfaces.<sup>41</sup> Coats can also be applied directly to a solid masonry substrate (with usually two coats) or to a metal lath on a frame (wood) construction (with usually three coats).<sup>42</sup>

Serving as the principal material in the stucco as a binder, Portland cement is an artificial cement manufactured by crushing calcium carbonate [ $\text{CaCO}_3$ ] (limestone or chalk) and aluminosilicate rocks (usually clay). Its principal components are lime (CaO) and silica ( $\text{SiO}_2$ ), which are calcined at high temperatures ( $\sim 2642$  °F/ $1450$  °C) in a rotary kiln to form hydraulic calcium silicates. This process produces a cement clinker consisting of four major phases: tricalcium silicate ( $\text{C}_3\text{S}$ ) or alite, dicalcium silicate ( $\text{C}_2\text{S}$ ) or belite,

tricalcium aluminate ( $C_3A$ ) or aluminate, and tetracalcium aluminoferrite ( $C_4AF$ ) or brownmillerite/ferrite.

In this process, the tricalcium silicate, which often constitutes almost half (50%) of the total cement volume, is responsible for the early strength or hardening process. The dicalcium silicate comprises a quarter (25%) of the volume and aids the cement to gain longer-term strength of the aging process. The tetracalcium aluminoferrite constitutes one-tenth (10%) of the cement volume and is responsible for the initial setting phase when the cement mix changes from liquid to a paste.<sup>43</sup> The cement clinker, along with the addition of small amounts of calcium sulfate ( $CaSO_4$ ) or gypsum (~5% to retard the cement setting process), can be manipulated to optimize specific properties of the cement.<sup>44</sup> Then, the cement clinker and gypsum are finely ground to a very fine powder.<sup>45</sup> These clinker phases are hydraulic and, when mixed with water, react to form various hydrated phases called calcium silicate hydrated gels (C-S-H) responsible for binding hydration of the portland cement binder. A "stronger, denser, and less permeable mortar" results from the development of calcium silicate hydrates during the stucco hardening process.<sup>46</sup> The residuals of unhydrated/partially hydrated clinker in hardened cementitious materials help identify types of cement microscopically.<sup>47</sup>

On the other hand, White Portland cement is preferred by architects since the early twentieth century for precast concrete, architectural concrete masonry products, and finishes, including stucco work. Small quantities of iron oxide and manganese oxide (from shale or limestone used in the process) influence the color in Portland cement, resulting in a grey mix. White Portland cement is manufactured using china clay and pure limestone or chalk, using oil in the kiln rather than coal, and grinding of the powder using pebbles, ceramic, or nickel molybdenum alloy spheres to obtain a whiter cement. Regardless of this process, the physical and chemical properties are the same as any ordinary Portland

cement.<sup>48</sup> White cements are commonly manufactured from Type I and III following ASTM C150. Type I Portland Cement, as established by ASTM C150 or 'normal or general-purpose Portland cement,' is the most common type of cement used for stucco work.<sup>49</sup> Type I Portland Cement has no limits on clinker phases and has a typical potential compound composition of 53% C<sub>3</sub>S, 23% C<sub>2</sub>S, 10% C<sub>3</sub>A, and 8% C<sub>4</sub>AF.<sup>50</sup> Even though Klumb initially specified it, the instrumental analysis did not find the use of White Portland cement at the Del Carmen Church (See Chapter 5).

Another essential component of stucco is fine aggregates or sand because it occupies a large volume percent of the mix. The type, grade, and shape of sand grains affect the quality, performance, color, workability, and shrinkage of the stucco. All fine aggregate grains are cemented together by the Portland cement paste. In modern Stucco, fine aggregates must conform to ASTM C897- Standard Specification Aggregate for Job-Mixed Portland Cement-Based Plasters. They should be clean and free from foreign organic impurities (such as loam, clay, or organic matter).<sup>51</sup> A good fine aggregate must be well-graded since impurities can interfere with the setting and hardening process of the Portland cement binder and its adhesion to the fine aggregates. The gradation consideration of sand is overemphasized since there must be minimum voids between large and small grains, while the remaining small voids should be filled with the cement paste for a workable mix. In other words, "...the optimum paste content of a [stucco] is a function of the volume of voids in the aggregate," being the optimum cement content as the minimum amount of cement paste required so that sand particles could be closely in contact filling void spaces.<sup>52</sup> Since stucco is applied by different coats (layers) over wall surfaces, the amount and type of fine aggregates can vary depending on the mix. As an example, a greater sand content in a brown coat might generate less shrinkage and thus is better for the application of a finishing coat.<sup>53</sup> For shotcrete-sprayed stucco, aggregates

preferred are generally rounded since angular may cause application issues in the machine.<sup>54</sup>

Other common materials on stucco mixes are mineral additions/additives and chemical admixtures. Following the definitions of the Portland Cement Association, additions are often blended with hydraulic cements during manufacture, while admixtures are materials added to before or during the mixing.<sup>55</sup> Historically, admixtures and mineral additions to concrete and stucco mixes have varied widely, influencing the durability and strength of stucco. Mineral additions or supplementary cementitious materials (SCMs) are added to Portland cement creating special cement mixes. Depending on the builder's goal, these SMCs can reduce the amount of cement used, reduce the hydration heat, and improve resistance to threats such as sulfate attack and alkali-silica reaction.<sup>56</sup> On the other hand, admixtures are often chemical components that should be carefully added at low doses to the mix. Chemical admixtures to stucco mixes are usually added to improve or reduce workability, retardation, or acceleration of mix setting (modifying the strength development rate), air entrainment, plasticizer/superplasticizers, water repellents (to reduce the permeability of the stucco), and color pigments. Some of these can be used in combination to modify the mix properties.<sup>57</sup>

Along with Portland cement and sand, hydrated lime or calcium hydroxide  $\text{Ca}(\text{OH})_2$  is often added as a plasticizer to improve a stucco's workability.<sup>58</sup> Better workability in the mix is achieved with proper proportioning of the different ingredients. Workability also influences the adhesion and cohesion of the stucco to the surface and plastic deformation process. Plasticizers such as hydrated lime should be added at the time of mixing.<sup>59</sup> Hydrated lime or caustic lime is calcium oxide made by burning calcium carbonate up to 1832 °F (1000 °C) to eliminate water and carbon dioxide from the material.<sup>60</sup> The formed clinker is then ground to a fine powder. Water is added to the powder forming a dangerous

explosive reaction as the mixture is heated and brought to a boiling point.<sup>61</sup> The mixture is then left for maturation for weeks, months, and even years before it is used, being a longest maturation period better for the material. Hydrated lime in stucco should follow ASTM C206, Type S, and ASTM C207, Type S or SA.<sup>62</sup> Even though lime is rare on shotcrete-sprayed stucco nowadays, in the mid-twentieth century, it was commonly used.<sup>63</sup> A hand specimen-samples obtained from the field investigations at the Del Carmen Church confirmed its use on the sprayed/shotcrete stucco.

Stearox "100," manufactured by Master Builders Co., is a water-repellent admixture widely used between the 1950s through the 1970s in concrete and stuccoes. In a 1961 publication of Master Builders Co., the company describes the product as "an integral water-repellent for concrete and mortar."<sup>64</sup> The material is characterized as a "soft white powder of 100% stearic acid, atomized to mix readily with the batching water" that can be used in Portland cement stucco and cement plaster. The directions indicate that the Stearox can be mixed on-site and should not be mixed directly in the water. The company highlights some of its properties as it reduces relative absorption to 60%, preserves the concrete's strength, can be easily added to the mixed paste, and only 0.20 to 0.35 lb need to be added per bag of Portland cement for good results. Even though Klumb specified the use of Stearox "100" in the dome, its use could not be confirmed since height limitations on the church prevented sampling of that area. Still, this photo from c. 1963-1964 suggests the use of a waterproof finish in the upper sloped areas of the dome.



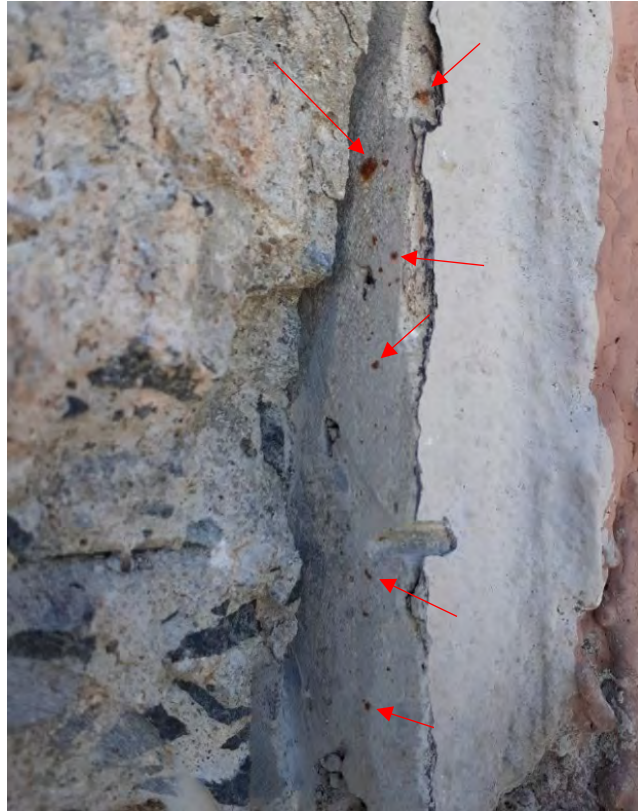
*Fig. 3.11* – Photo of the dome at the southeast side of the Church. Photo by Conrad Elger & Alexander Georges c. 1964-1966. Source: Henry Klumb Collection – AACUPR.

Another common additive for waterproofing concrete was ferrous particulate (filings), which have been used since the early twentieth century.<sup>65</sup> A cementitious waterproofing system -known as a 'Metallic system' -, is composed of a mixture of Portland cement and sand blended with a pulverized or finely graded ferrous-iron filings/aggregate.<sup>66</sup> When water is added to the mix:

"... the water acts as an agent permitting the iron filings to oxidize. These materials expand due to this oxidizing, which then effectively seals the substrate and prohibits further transmission of water through the material."<sup>67</sup>

Eventually, the ferrous particulate-filings expand, occupying the pores, sealing the concrete surface, and protecting the substrate from water infiltration.<sup>68</sup> This process is known as a redox reaction in which iron is oxidized at the same time oxygen is reduced

with the presence of water molecules ( $\text{H}_2\text{O}$ ) -  $\text{Fe} + \text{O}_2 \rightarrow \text{Fe}_2\text{O}_3$ , thus decreasing water penetration in the stucco by reducing porosity and permeability. Like traditional stucco, the metallic waterproofing system is usually applied in two to three coats over a concrete substrate. Followed by the usually specified preparation of substrates, the first coat can be applied with the traditional Portland cement-sand mix, and then the second coat is applied with cement-sand and the iron filings. Some 1950s handbooks recommended water spraying the surfaces to accelerate the corrosion process.<sup>69</sup> Although the system is generally applied by trowel, other methods include spray or brush.<sup>70</sup> This waterproofing system has been used extensively by engineers in infrastructure projects such as tunnels, underground vaults, swimming pools, sewage facilities, etc. It has been recognized as a successful technique since it protects the concrete substrate from moisture and deleterious chemical agents. Also, recent studies have found that the inclusion of controlled amounts of iron filings can enhance the workability, compressive tensile, and flexural strength of concrete mixes.<sup>71</sup> The addition of iron filings did not appear to change the color of the dome stucco significantly.



*Fig. 3.12* – A cross section of the dome stucco with the visible ferrous particulate fillings after sampling on the northwest elevation. Photo by Author, February 2020.

Lastly, along with Portland cement and fine aggregates, water constitutes the third essential ingredient for a workable stucco mix. All scientific and professional concrete institutions acknowledge that suitable water for a stucco mix "should be clean and fit to drink" as well free of any "undesired material or organic substances."<sup>72</sup> Water is an essential ingredient since it allows the chemical reactions necessary. The amount of water affects the strength of a stucco. For example, an excess of water in the mix leads to greater porosity, low density, and lower strength. It is essential to acknowledge the water-cement ratio of a mix; this is the ratio of the total weight of water / the weight of cement to prevent this phenomenon. A lower ratio indicates higher strength and durability, but poor workability and a higher ratio can be the opposite.<sup>73</sup> A balanced W:C ratio is vital to ensure proper hydration and to prevent future deterioration issues.



Water is also essential in the setting and hardening (curing) of the stucco, a complex chemical reaction between the Portland cement and water known as the hydration process.<sup>74</sup> In this process, two silicates of Portland cement, alite ( $C_3S$ ) and belite ( $C_2S$ ) are both initially responsible for the strength of the cement in the first seven (7) days of setting, while alite takes the lead in this process after that week. With the presence of the small amounts of gypsum, aluminate ( $C_3A$ ), and ferrite ( $C_4AF$ ), calcium sulfoaluminate hydrates form, producing ettringite and then transforming to a monosulfate form. Then, the interactions between the clinker compounds occur while the mix hydrates.

The protection of the stucco from external agents such as the sun and wind is essential to prevent interference with the cement hydration because they all cause moisture evaporation from the stucco. A proper curing process needs balanced external temperatures (between 40 and 90 °F). Balanced external temperatures are necessary since Portland cement stucco cures at high temperatures, and internal chemical components can react adversely, altering the microstructure of the cementitious material.<sup>75</sup> A good amount of water, including wetting the stucco during the curing process, is necessary so that the cement particles develop a strong bond with the fine aggregates. In both hand and machine-spray applications of stucco, the curing process usually takes up to 28 days. Because of finer aggregates and a higher cement paste content, stucco has a higher shrinkage potential that can eventually lead to cracks or micro-cracks.<sup>76</sup> These cracks can be detrimental to the material, inducing further deterioration processes.

### *3.2.2 Stucco application processes*

The amount of water, the difference in mix proportions, substrate preparation, the curing process, and the application procedures for each layer all influence the mechanical bond between the coats and the substrate. Bonding is essential for the strength and durability of stucco. The substrate must have complete absorption characteristics to

provide a good attraction with the stucco and prevent deterioration issues such as material stresses leading to debonding and cracking on the surface. On shotcrete-sprayed stucco, since its application occurs at a high velocity, if the substrate is well prepared, the sprayed stucco usually has a stronger bond since the substrate receives "a rich, tightly compacted paste layer."<sup>77</sup> In both traditional and sprayed cases, the stucco must intrude on the substrate's pores and cracks by capillary action for an effective final bond. Despite the stucco bonding process being initially mechanical, the curing or hardening transforms also leads to a mechanical and chemical process.<sup>78</sup>

Before applying stucco coats to a masonry substrate, surface preparation is essential to provide a good durable stucco finish. Concrete substrates need to be "absorbent and textured," two crucial principles in preparation for good bonding.<sup>79</sup> Throughout the 20<sup>th</sup> Century, Portland cement stucco manuals and standards have recognized the importance of surface preparation for adequate bonding, outlining several requirements. Some of these specifications include the removal of any deleterious substances and oils from previous forms, the use of sandblasting, high-water pressure washing (min. of 3000 psi), acid etching, or mechanical means such as grinding, chipping with chipping hammers, and bush hammering on the concrete surfaces.<sup>80</sup> Current practices also include 'bonding agents' applied to the substrate or added to the mix to increase the bonding between the stucco and the concrete.<sup>81</sup> A rough surface is ideal for good stucco bonding, especially the first or 'Scratch' coat. For shotcrete-sprayed stucco, bond strength tests have demonstrated that the surface preparation has a significant impact on the bonding than the mixture composition.<sup>82</sup>

On hand-applied stucco, a two-coat system, with a 'Scratch' and 'finishing' coats are common on concrete and masonry substrates, resulting in between a 1/2" and 3/8" inch stucco.<sup>83</sup> Standards, construction specifications, and regional traditions usually

influence the different ingredient proportions by each stucco layer.<sup>84</sup> In a three-coat system, a 'Scratch' coat is scored or scratched with a trowel's point creating a rough surface in preparation for the 'brown' coat, which is then applied and floated to create a uniform surface.<sup>85</sup> Simultaneously, the 'brown' coat provides a good surface for the 'finishing' coat.<sup>86</sup>

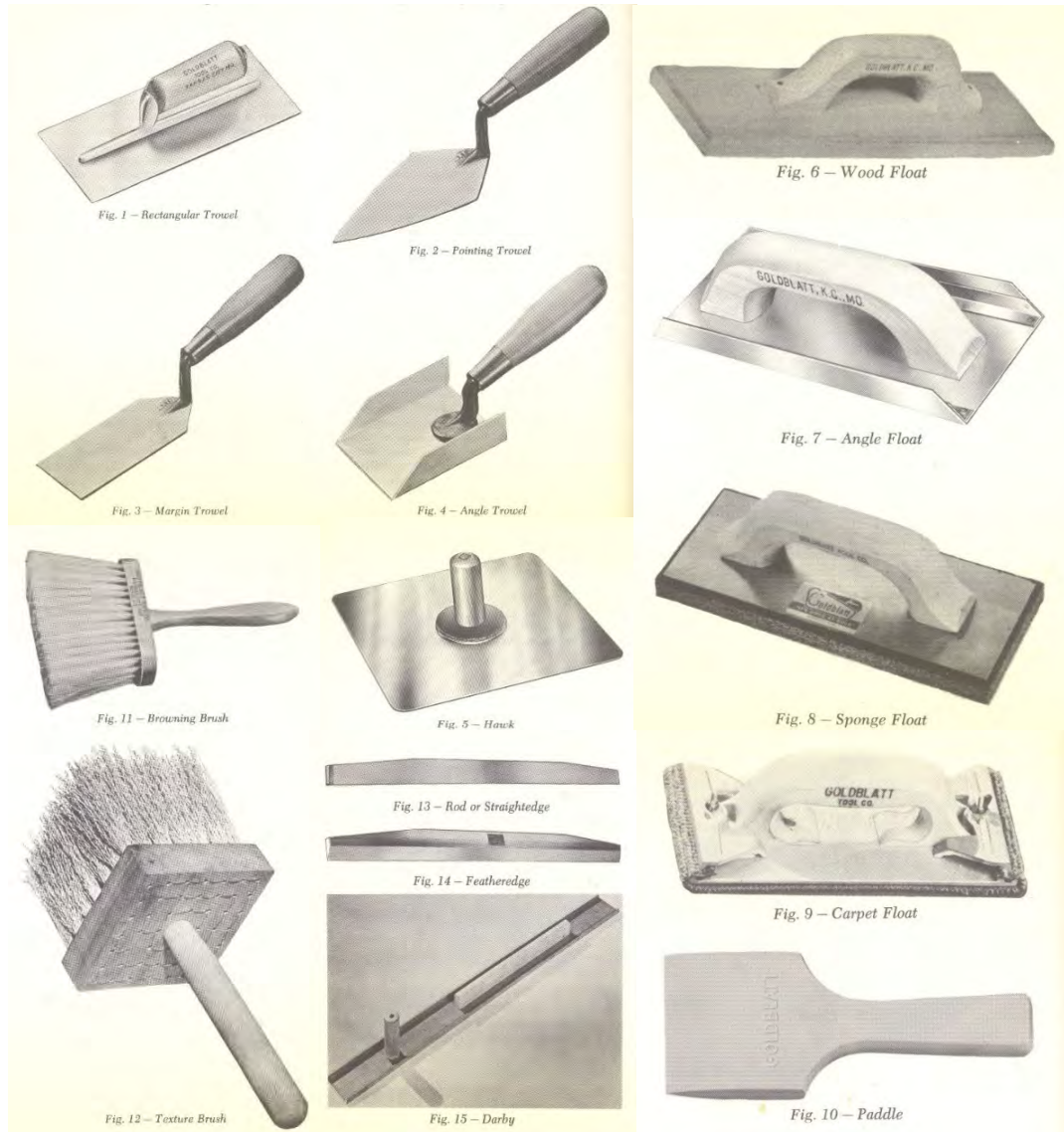


Fig. 3.13 – Common plastering tools in the mid-twentieth century. Source: Manual of Lathing and Plastering by John R. Diehl (1960), p. 84-88.

Shotcrete or sprayed stucco through a machine can be applied to a substrate by dry-mix or wet-mix processes. Before the application of one of these two processes, the materials for the mix are measured in a process known as 'Batching' by volume or weight. All surrounding surfaces are protected before the application of sprayed stucco.<sup>87</sup> The dry-mix process, which was invented first, uses low pressure and high air volume machine in which the pre-damped dry components of the stucco mix (Cement, sand, admixtures) are thrown into a mixer and transported to the gun. Then as water and/or liquid admixtures are added by pressure directly to the nozzle, the mix is sprayed onto the substrate.<sup>88</sup> The dry mix process was particularly considered to form shell structures in the mid-twentieth Century, something seen in the first proposal for Del Carmen Church developed by Klumb and Komendant.<sup>89</sup>

On the other hand, in the wet system, all ingredients, including water, are thoroughly mixed and then introduced to the machine, later sprayed through a hose. The wet process is a cleaner and less dusty application system.<sup>90</sup> Shotcrete-Stucco can be applied in vertical and horizontal surfaces, using one or several layers starting from ¼" of thickness. Decorative finishes are often done in a final to 'flash' coat up to ¼" inch thick.<sup>91</sup> After the stucco is sprayed, some plasterers, as Nordmeyer mentions, "leave the wall like that; others trowel the wall to densify the stucco." Even though densifying the stucco have benefits like reducing shrinkage cracking, if not done under the proper environmental conditions, it can have consequences on the bonding of the mix and the final dry stucco.<sup>92</sup> Still, the application procedures vary regionally and by project.<sup>93</sup>

<b>Dry-mix process</b>	<b>Wet-mix process</b>
Instantaneous control over mixture water and consistency of the mixture at the nozzle to meet variable field conditions	Mixture water is controlled at the mixing equipment and can be accurately measured
Better suited for placing mixtures containing lightweight aggregates or refractory materials	Better assurance that the mixture water is thoroughly mixed with other ingredients
Delivery hoses are easier to handle	Less dust and cementitious materials lost during the shooting operation
Well suited to conditions where the timing of placing the shotcrete cannot be predicted or is intermittent	Normally has less rebound, resulting in less waste
Lower volume per hose size	Higher volume per hose size

*Fig. 3.14 – Comparison of dry-mix and wet-mix processes. Source: ACI 506R-16 – Guide to Shotcrete, p. 3.*



*Fig. 3.15 & 3.16 – Dry-mix application of Shotcrete in the 1960s. Fig 6 shows the use of a hand hopper machines was also common in the era, suitable for sprayed finish coats. Source: Manual of Lathing and Plastering by John R. Diehl (1960), p. 176 & 91.*



One of the central aspects of Shotcrete is workmanship. For the application of sprayed stucco, an adequate crew is required with a leading nozzleman.<sup>94</sup> The dry mix process relies heavily on the nozzleman's skill in regulating and controlling the amount of water in the nozzle during the application. Also, the nozzleman is responsible for selecting the nozzle size, screeds, the starting point for the job, sequence shooting, distance, and positioning.<sup>95</sup> As an example, the angle of the application by the nozzleman can impact the surface texture and appearance. A rolling or wavy-uneven surface of shotcrete stucco is usually attained by shotcreting at angles less than 90 degrees.<sup>96</sup> Another aspect is the

sprayed stucco's impact velocity over the substrate, which is essential for proper bonding.<sup>97</sup> Controlling the impact velocity requires experienced construction workers since an improper application can cause differences in strength, durability, and material finish. Since the early twentieth century, Shotcrete's application dependency on the expertise and workmanship of workers has resulted in shoddy work leading to its slow acceptance as a reliable technology by designers and construction professionals.<sup>98</sup> Eventually, the durability of Shotcrete depends on the water/cement ratio, the void interior system, and the quality of ingredients of the mix, all of which the nozzleman has a great responsibility.

All cementitious materials, including stucco, require curing. This process starts just after water is added to the stucco mix in a process called hydration, when the material hardens, losing its internal moisture in an appropriate exterior temperature and humidity. The curing process must "maintain moisture and temperature conditions in a freshly placed mixture to allow cementitious material hydration to occur so that the potential properties of the mixture may develop."<sup>99</sup> A good and strong internal bond between the aggregates and Portland cement are desired properties in a stucco formed in the curing process. Pre-wetting or damping of the substrates is always required since it aids the stucco to maintain the necessary amount of moisture for the hydration process. As stucco is applied on exterior surfaces, environmental factors such as the sun, wind, and rain have a significant impact on the curing process. Wind and rain can drive increased moisture to the surfaces, and the sun and wind can evaporate moisture from the stucco, causing premature drying and affecting its strength. To avoid these environmental factors, like in hot and humid weather, builders have developed best practices to protect the stucco during the curing process. Some requirements include curing compounds/chemical admixtures to the mix, wetting/ponding the surfaces periodically -daily for seven (7) days-, installing absorptive mats over the surfaces to control moisture and temperatures in the

material, and covering the surfaces with impermeable sheets.<sup>100</sup> As mentioned, an ideal finished hardened stucco should have among its properties a good weather resistance, a good and strong bond between the stucco and the substrate, and good tensile and compressive strengths.<sup>101</sup>

Besides its physical and mechanical properties and its protective role over substrates, Stucco has a prominent role in masonry buildings' aesthetics, being used as an expressive medium for centuries. In Portland cement stucco, the finishing coat is the thinnest and usually where architects, designers, and users experiment aesthetically applying texture, colored coatings, and a wide range of adornments. Over the decades, some decorative practices had gain recognition, such as the use of colored cement, controlling the consistency of the mix, variations on type, shape, and size of aggregates, and the plastic manipulation of the coat on site. As the Portland Cement Association states, the texture is used to “provide highlights, depth, continuity, segmentation, and even achieve the look of a completely different construction material such as wood timbers, brick, or stone masonry construction.”<sup>102</sup> There are some additional considerations for Shotcrete-sprayed stucco since the type of finish can affect the bonding with the substrate. Although a sprayed stucco can be troweled with a wooden trowel after its application, it is recommended to leave it ‘undisturbed’ to produce a ‘Gun (natural) finish,’ which is “compact, rich and creamy rather than dry or sandy.”<sup>103</sup> Specific texture applications include ‘brooming’ to produce a roughened surface and floating with a wooden or rubber float for a soft finish.<sup>104</sup> Both machine and hand stucco applications require a certain amount of expertise since an improper application can result in uneven surfaces and difficulties to match a final finish. The stucco-sprayed surfaces must be brushed one hour later to remove any rebound dust or undesirable remaining.



### 3.3 Historical evolution of Portland cement stucco

In the late nineteenth and early twentieth century, the development of concrete was still in its early phases. Concrete was treated and seen as a purely monolithic industrial material and suitable for structural frames. This is one reason for the building industry's distrust towards its potential as an architectural material. Without any standards and a few understandings of the material, construction with concrete resulted in many failures and accidents. Eventually, the concrete surfaces developed under these circumstances were subject to rapid weathering leading to cracks, crazing, and deteriorated exteriors, picturing concrete as a decaying material.<sup>105</sup> According to Ada Louise Huxtable, "...[in that era] the urgent need to develop satisfactory surfaces and finishes had been postponed or ignored in the rush of utilitarian construction."<sup>106</sup> As stucco was seen as 'neutral,' malleable to any form without "attracting much attention," it became a source to cover these early concrete surfaces.<sup>107</sup>

As the U.S. economy changed, a new continental rail network made possible the sprawl of significant suburban development and the accessibility of industrially produced Portland cement, which also aided the expansion of its domestic production.<sup>108</sup> As the popularity of Portland cement products and stucco rose in the 1900s, a series of products that featured craft treatises, product literature, and specialized journals outlined the tools, techniques, and materials for the application of Portland cement stucco.<sup>109</sup> Still, complaints about the early failing product known as the "common practice of rubbing cement mortar into exposed surfaces, forming a thin finishing layer" were frequent.<sup>110</sup> Advances in scientific knowledge on Portland cement, motivated by the industry, were also crucial for accepting Portland cement stucco. For example, in 1904, the American Society for Testing and Materials (ASTM) adopted the first standard for Portland cement, which led to a series

of tests and scientific advances throughout the next decades.<sup>111</sup> These industry changes aided the use of Portland cement stucco in the continental U.S. and abroad.

In Puerto Rico after 1899, with the introduction of a tremendous amount of Portland cement by the Federal and Insular governments to the Islands, the use of lime-based stuccoes diminished, thus becoming almost obsolete. Its durability, high strength, impermeability, and almost free maintenance in contrast with the high-maintenance lime stucco, aided Portland cement stucco's perception as a "superior material."<sup>112</sup> Traditional lime plaster, the base for historic stuccos and plasters, was neglected since Portland cement stucco was believed not to need periodic repair or renewal, had stronger resistance to weathering and could set underwater.<sup>113</sup> Ultimately, the standardization trends of building materials in that era pushed the use of standard refined Portland cement mixes, replacing the craftsmanship of earlier stucco traditions.<sup>114</sup>

In the U.S., Portland cement stucco was considered an inexpensive fireproof material, quickly praised for its malleability to create imitative, more expensive decorative surfaces, thus becoming a symbol of social status.<sup>115</sup> As Concrete continued to be seen as a 'back up' unappealing industrial material, Portland cement stucco became readily treated as a 'masonry veneer' which could be applied to any substrate, including wooden framed houses, both new and old. In this sense, Portland cement stucco was readily cheap, durable, and seen as 'more permanent.' Homeowners sought to showcase stucco textures on their new balloon framed houses or renew their old houses covering their walls with stucco.<sup>116</sup> Perhaps, the scientific advances and the popularity among the public (not so with architects) of Portland cement stucco aided the shift in the appreciation of concrete from a purely engineering material to an expressive architectural medium as a 1915 article in *Concrete-Cement Age* journal mentions:

“The failure [of Concrete] to come more fully into its own as a...building material has been due not to the material itself but to the lethargy and indifference of the great body of architects and builders to a wonderful material. The popularity of the stucco house indicates public recognition of the beauty of concrete and a reaching or for better construction.”<sup>117</sup>

Stucco was added to the list of popular Portland cement derivate products such as hollow concrete blocks and cast-in-place decorations that helped transform the perceptions of concrete as a building material.

Since the 1910s, a variety of novelty Portland cement stucco finishes or textures were marketed in trade catalogs, becoming a popular option to decorate wood-framed houses and solid masonry buildings. As a result, the stucco application was increasingly differentiated between the two general types -solid substrate or lathing and sheathing. Stucco finishing coats were usually given smooth-troweled finish or rough finishes that included “scored or lined” to imitate stone masonry.<sup>118</sup> In this era, the experimentation with color pigments and colored aggregates was increasingly accepted.<sup>119</sup> As bonding failure was a constant problem, surface preparation practices were established for stucco applications such as acid etching (with 25% hydrochloric acid) and others that prevail today, such as cleaning with water and wire brush, chipping and scoring to roughen the substrates.<sup>120</sup> At the same time, industry organizations marketed textured finishes such as Smooth Troweled, Stippled, Sand Floated, Sand Sprayed, Rough Cast or Patter Dash, Sponge finish, and Exposed aggregate finishes.<sup>121</sup> It was also around the 1910s when the differentiation between plaster, as a lime-based mixture for interiors, and Portland cement stucco for exteriors began to appear in trade literature.<sup>122</sup>



Fig. 3.17 – Standard Stucco Finishes marketed between the 1910s and 1920s. Source: *The Stucco House* (1921), p. 64.

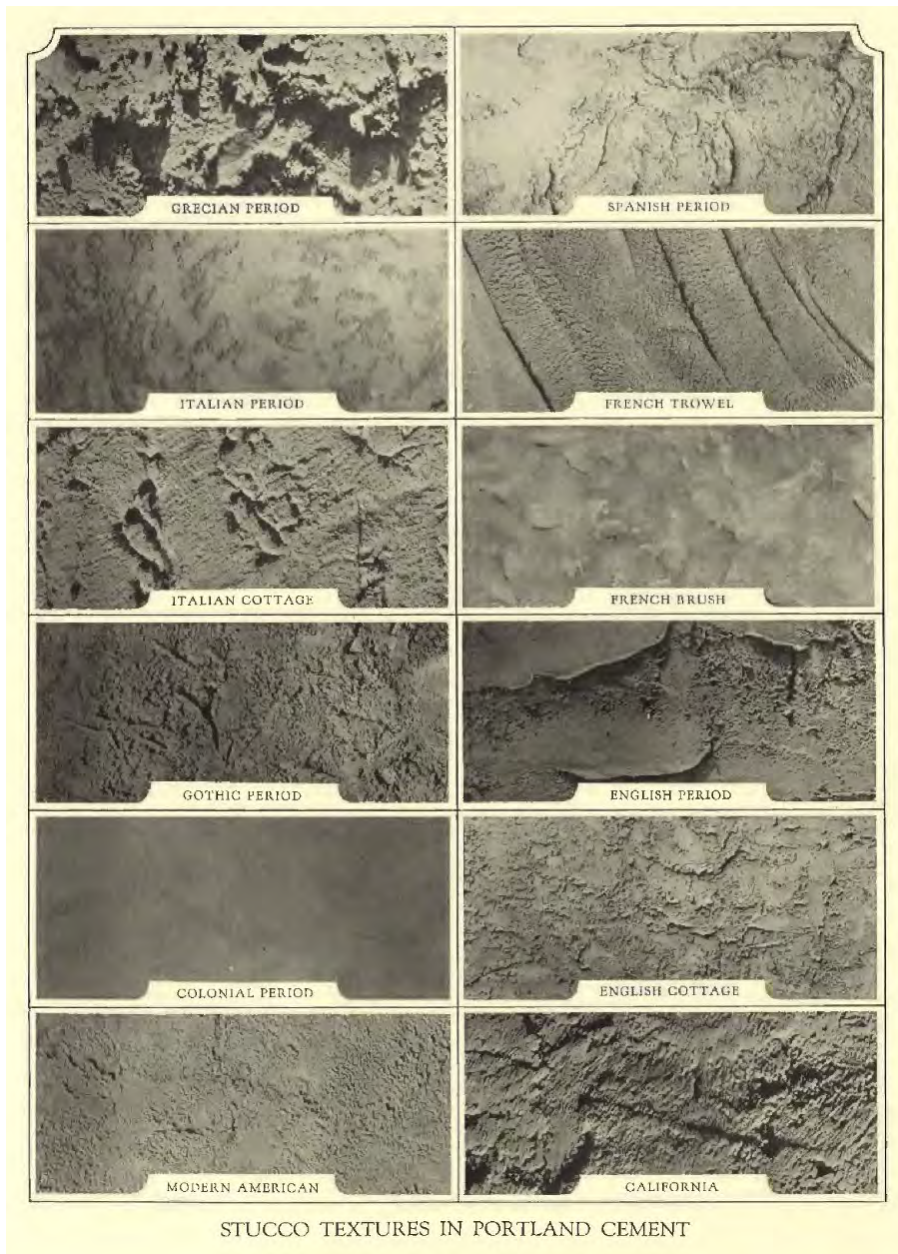
Along with the market and scientific advancements between the 1910s and 1930s, the use of stucco on domestic architecture, both in bungalows and wooden framed suburban dwellings, was vital for its wide acceptance in the industry. In 1929, architect Oswald C. Hering declared the versatility of stucco to "almost all the prevalent styles in domestic architecture."<sup>123</sup> Besides the aesthetic possibilities in residential architecture, in the 1920s, stucco was believed to be 'incombustible' to fire exposure and an asset to raise the value of properties.<sup>124</sup> Like concrete, Portland cement stucco was featured as an

almost 'no maintenance' material since it was believed as permanent, that improved and became stronger with age, 'but did not decay.'<sup>125</sup>

As American architecture in the early twentieth century looked at colonial revival styles as a way to reaffirm nationalism, Portland cement stucco became the medium of expression for prevalent nationalistic and white heritage sentiments as expressed by Hering:

"Stucco and concrete adapt themselves to any form of plastic design, and manufactured stone to articulated design, and each lends itself readily to modifications of almost every style that could be conceived as suitable in respect to our national inheritance. We are mainly a mixture of the Anglo-Saxon, Germanic, Gallic, and Romanic races, and our houses may properly reflect a suggestion of English, German, French and Italian styles past and present, all of which are readily expressed in terms of stucco, concrete and manufactured stone."<sup>126</sup>

As U.S. architects featured revival styles, a wide variety of stucco finishes with names such as "English Cottage," "English Manor," "Italian," "Mexican," "French Farmhouse," "Spanish," "Californian," and others, became widely publicized in trade catalogs, specifically for dwellings since the 1920s. Both the bungalow and Spanish revival architectural styles in this period were key to showcase the sculptural possibilities of cement stucco.



*Fig. 3.18 – Standard Stucco Finishes marketed since the mid-20<sup>th</sup> century. Source: Modern Modes in Better Plastering (1926), p. 20.*

The material was increasingly seen as a decorative medium by designers and architects who quickly took advantage of its finish variations and incorporated mosaics, tiles, and other decorative applications placed by hand.<sup>127</sup>



Figs. 3.19, 3.20 & 3.21. Hotel Americana in the Central Aguirre in Salinas, Puerto Rico, built-in 1926, which features the 'Modern American' rough stucco texture finish in both interior and exterior walls. Source: Yanitza Montero Rivera (2019) & AACUPR.

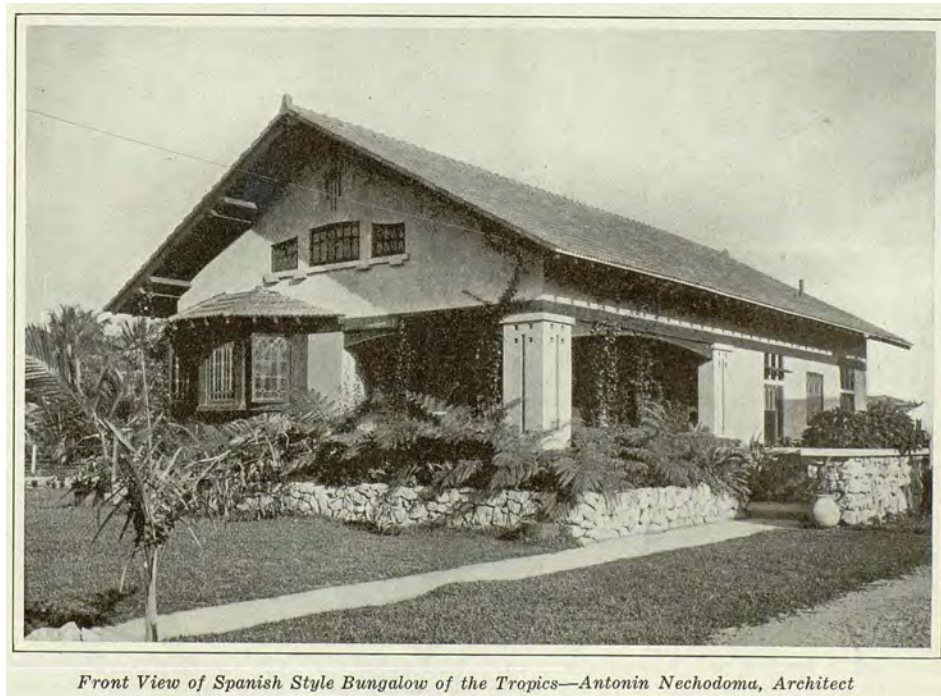


Figs. 3.22 & 3.23. In Puerto Rico, the Spanish revival buildings with its 'Spanish' rough stuccoed surfaces were common, especially in the 1930s. One of the best examples in the University of Puerto Rico Buildings designed by architect Rafael Carmoega in the 1930s in the Spanish Revival Style. Photos by the Author, 2018.





The composition of the concrete gives a pleasing texture to the finished surface.



Front View of Spanish Style Bungalow of the Tropics—Antonin Nechodoma, Architect

Figs. 3.24 & 3.25. In Puerto Rico, Czech architect Antonin Nechodoma incorporated the use of mosaics and flat Portland cement stucco. Source: Earl K. Burton, "Concrete Bungalows in Porto Rico" *Keith's Magazine on Home Building*, Vol. XXXV, No. 4, April 1916, p. 246 & "Spanish Style Bungalow of the Tropics: Details of a Dwelling to Meet Warm Climate" *Buiding Age*, April 1914, p. 19.

In the beginning, these "Revival" finishes were categorized by the difference in textures; then, in the mid-1920s, assigned colors became the norm.<sup>128</sup> Besides these marketed finishes, the plasterer was often allowed to create a variety of textures since types of finishes were 'limited only by the skill of the plasterer.'<sup>129</sup>

Even though there was no standard mixture in the early days, a basic early twentieth century Portland cement stucco mixture consisted of 1-part Portland cement, 2 ½ to 3 parts sand or fine aggregate, Hydrated lime- no more than 15% to 20% by volume of the cement and water.<sup>130</sup> All coats used the same ingredients except for the finishing coat, which required more hydrated lime. Besides the common constituents of the mixture, trade catalogs in the mid-1920s discussed incorporating other plasticizing agents such as 'Asbestos flour or fibers,' clays, pulverized marble or silica and diatomaceous earth or diatomite.<sup>131</sup> A machine mixer, invented in the 1900s, was often recommended and specified for stucco work.<sup>132</sup>

Despite being marketed as a cost-saving material since it needed no paint, small quantities of pigments and sands with different colors became part of the stucco mixes. The material became better understood by the industry, and architects sought to improve its appearance from the monotonous gray color. The production of White Portland cement was essential for the integration and acceptance of colored stucco finishes in that era. In the mid-1920s, the application of oil painting and 'Cold water washes' became two other specific ways to attain or change the color on Portland cement Stucco.<sup>133</sup> Exposed aggregates are another popular surface finish for Portland cement stucco, which used pebbles and small stones of different colors, sizes, and shaped and produced by acid washing or tooling. Other applications for texture finishes included dash coats/heavy troweled stucco, hand-thrown stucco, and etched textures using a wire brush, stencil, or sandblasting.<sup>134</sup> Both color and texture were seen as an asset for the material in a time when the designer's artistic expression, craftsmanship, individuality, and 'harmony' with the environment was a priority within standardized architecture.<sup>135</sup>

In the early 1930s, the Portland cement industry continued facing a lack of standardized practices. In this decade, an emphasis on skilled plasterers,

professionalization, scientific advances, and laboratory testing dominated the discussion in Portland cement/Concrete trade catalogs and scientific journals. Despite such changes, it is often recognized that plasterers continued the trade by teaching and promoting traditional plastering techniques.<sup>136</sup> A 'standard' Portland cement stucco mixture was commonly specified since the early 1930s consisting of "1-part Portland cement, 1 part commercially hydrated or well-slaked lime and six (6) parts of sand," and water management and flashing procedures to avoid stucco deterioration were increasingly showcased.<sup>137</sup> As flat white stuccoed walls became popular in the 1930s with the rise of modernist trends, paint was quickly the preferred aesthetic option. The paint was used in the late 1930s was progressively adapted to support the alkalinity of fresh concrete.<sup>138</sup>



Figs. 3.26, 3.27 & 3.28. Suburban houses developed by the Puerto Rico Reconstruction Administration (PRRA) at the Urb. Eleanor Roosevelt in Hato Rey, San Juan (1937) with a smooth portland cement stucco finish. Source: Colección Digital Biblioteca Escuela de Arquitectura – Universidad de Puerto Rico, Recinto de Río Piedras (UPRRP).

Between the 1900s and 1940s, few design attempts are documented using exposed or 'Fair-face' Concrete. This may well be due to the long-standing tradition of stuccoed masonry surfaces in Puerto Rico beginning in the sixteenth century. The same prevailing problems from the late nineteenth century -surface spalling, deficient color control, excessive shrinkage and thermal cracks, and poor corrosion control- persisted. Still, the wide variety of surface treatments developed in these four decades, along with the scientific/technical advances such as intensive concrete inspections, development of air-entraining agents, protections for mixes and new technologies, lined up with the U.S. federal government needs of massive and quick infrastructure for World War II. In this sense, the War economy influenced the use of exposed concrete. The need for massive infrastructure projects led to the development of specifications for formwork and technical practice to eliminate exposed surface imperfections.<sup>139</sup> By the mid-twentieth century, the look of raw concrete and formwork was embraced.<sup>140</sup> As a consequence, thousands of unskilled construction workers learned about poured-in-place concrete techniques.<sup>141</sup>

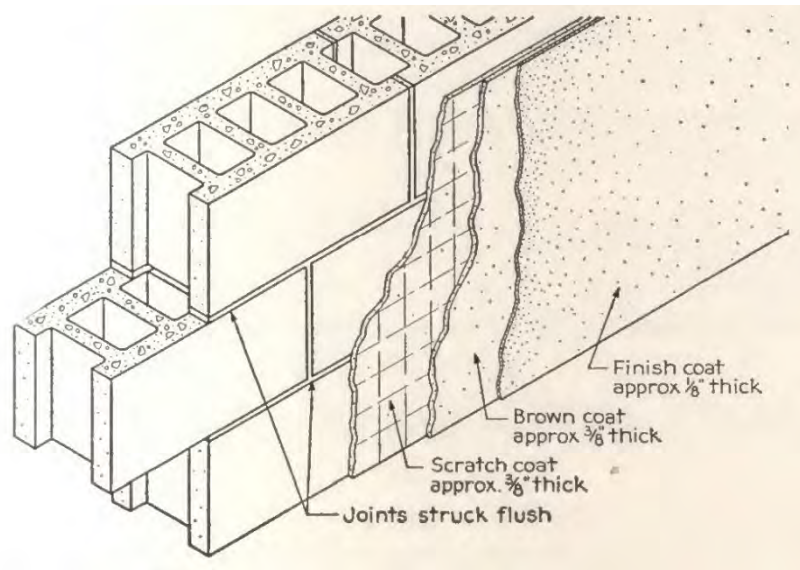


Figs. 3.29, 3.30 & 3.31 -The house of architect Antonin Nechodoma in Miraflores, Santurce (built c.1913) & El Falansterio Housing, designed by Architect Jorge Ramírez de Arellano for the Puerto Rico Reconstruction Administration (PRRA) in 1937. These two are examples of the experimentation with early 'fair-faced' exposed concrete in Puerto Rico between the 1900 and 1940. Source: AACUPR.

Concrete in the post-war was still stuccoed and painted.<sup>142</sup> A practical guide for classrooms and laboratories published by the Portland Cement Association in 1948 praised how the "...texture of the concrete masonry and the natural affinity of the Portland cement in the stucco for that in the concrete units make [it] an ideal stucco base."<sup>143</sup> However, perhaps indicative of the coming trends, the same publication discussed the stucco only in a small section compared to a more extensive discussion of other types of concrete finishes. Besides Portland cement stucco, a variety of concrete finishes and textures were widely used. In 1945 the prevailing styles of concrete finishes included Portland cement stucco, Rubbed or exposed surfaces, paintings using Portland cement paint, picked surface finish (by bushhammering, tooling, or sandblasting), Granolithic finishes/exposed aggregates, acid treatment, masonry facing (finish to represent ashlar masonry), cast concrete slab veneers, concrete moldings, and ornamental shapes and coloring materials or pigments for concrete mixes.<sup>144</sup> Even though Portland cement stucco and plaster was still considered a material of 'great permanence,' with high strength, hardness, and water resistance, reports from the era mention the 'general reluctance' of contractors to use it because of relatively high drying shrinkage issues.<sup>145</sup>

By the 1950s, relatively few changes to Portland cement stucco mixes and applications were developed. Synthetic admixtures for waterproofing were tried and recommended thicknesses for stucco coats varied from 3/8" for cast-in-place and 3/4" for concrete masonry-blocks.<sup>146</sup> A 1951 concrete masonry handbook mentions the growing popularity of concrete masonry blocks and demand for Portland cement stucco and 'white or colored surfaces' using Portland cement paints.<sup>147</sup> Still, after WWII, with the development of new technologies that perfected poured-in-place, prestressed, precast concrete technologies, "the sculptural articulation [and expressiveness] of concrete

became increasingly apparent.”<sup>148</sup> Exposed rough, unfinished concrete became the symbol of architecture in that era.



Figs. 3.32 – Application of Portland cement stucco to concrete block masonry wall as outlined in the 1950s, which has not changed at all to present day standards. Source: Concrete Masonry Handbook for Architect, Engineers, Builders by the Portland Cement Association (1951), p. 45.

Architects in the early 1960s continued experimenting with concrete technologies; exposed or ‘fair-face’ concrete finishes diminished the use of Portland cement stucco. Continued research has contributed widely to this trend; as an example, Precast concrete made possible various exposed finishes because of its controlled fabrication standards. Precast cladding panels were installed on facades and sealed with gasket or mastic from weathering protection.<sup>149</sup> On the other hand, it was not only about style and taste but reducing construction costs, as Henry Childe mentioned in 1964: “cement rendering [Stucco] should not be applied to new concrete, because more attractive surfaces can be obtained at less cost.”<sup>150</sup> The perception of Stucco as an ‘abused’ or excessively used finish from earlier decades and as a material for early twentieth-century decorative arts also contributed to this transition.<sup>151</sup>

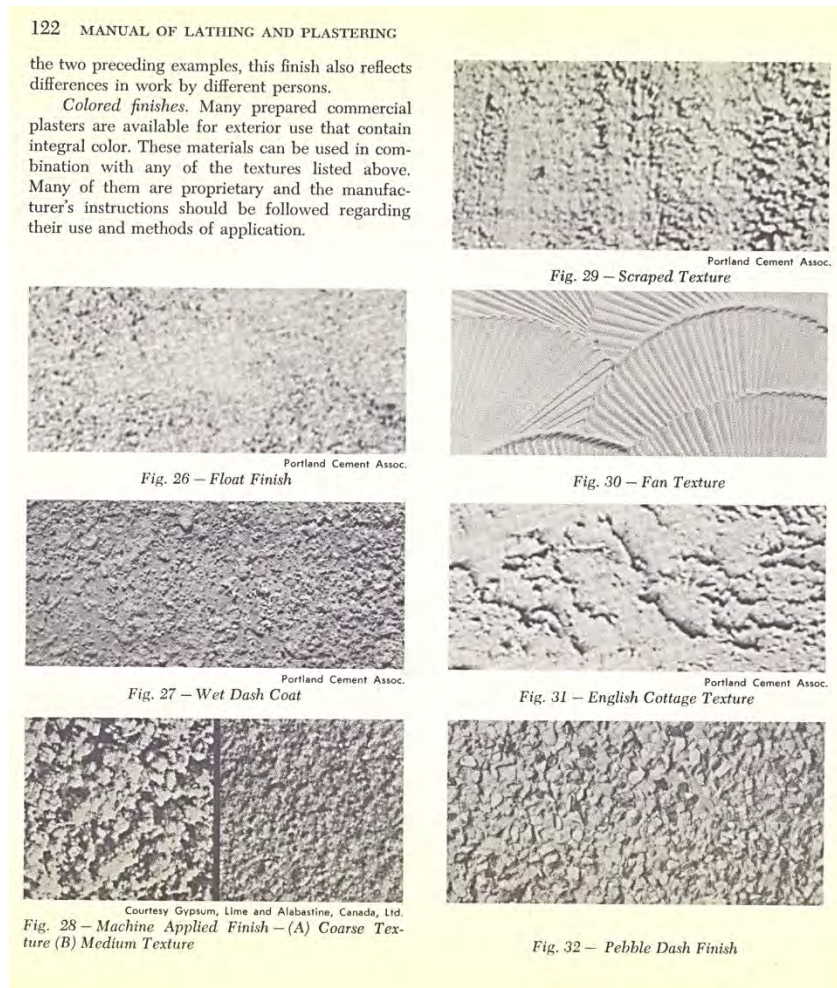


Despite its displacement as the predominant surface finish, trade literature from 1965 outlined the type of concrete finishes in the era, including Portland cement stucco as an applied surface treatment.<sup>152</sup> New architectural discourses regarding the aesthetic and practical needs of stucco and plaster emerged. The 1965 book *Manual for Lathering and Plastering* by architect John R. Diehl provides an in-depth overview of the state of the plastering trade and the common theoretical discourses towards the use and application of stucco in the mid-1960s.

These attitudes toward stucco came from philosophical trends that emphasized functionality, form, and space -recognizing its “distinctive and intrinsic” qualities-, rather than the aesthetic distinctiveness of materials. One of these postulates that stucco has a visual function in architecture in the refinement, “hiding or masking,” and embellished with color or texture works of arts and rough architectural and structural elements. Stucco was also recognized with a role within the definition of architectural spaces “as the major component of a space enclosing or dividing elements such as a partition, a screen, a wall, or a ceiling.” Structural and fire protection functions complete the list.<sup>153</sup>

Still, the original function of the stucco finish coat ‘to provide acceptable visible surfaces’ continued to get the attention of designers. The recommended Portland cement stucco finish applications of the 1960s included traditional smooth troweled-Portland cement-sand finishes, float finishes, roughcast/wet-dash coat finish, machine applied (sprayed) finish, scraped or American texture, Fan texture, English cottage texture, Pebbledash, and colored finishes (with pigments). Despite being rarely mentioned in trade literature of the era, the application of sprayed stucco was recommended as Childe mentioned in 1964: “...a rough surface on a wall...can be obtained by spraying mortar on to the surface, or the material can be thrown on to the wall with a scoop.”<sup>154</sup> These finishes

constitute an evolution and consolidation of the stucco trends from the first half of the twentieth century.



Figs. 3.33 – Common exterior stucco finishes in the 1960s. Source: Manual of Lathing and Plastering by John R. Diehl (1960), p. 122.

### 3.4 Historical evolution of Shotcrete 1907 - 1960s

“The ‘cement gun’ was another revelation in the way of mechanical ingenuity which promises to revolutionize stucco work.” – “The New York Cement Convention and Exhibition,” *Cement Age* 12, No. 1, January 1911, p. 5

The early 1900s was an era framed by the expansion and experimentation with Portland cement products in the U.S., where significant technological changes took place.

Industry leaders, inventors, engineers, and architects sought to improve and standardized concrete building technologies and their applications. In this context, the invention and instruction of the 'Cement Gun' machine were not unusual. As engineer Pietro Teichert mentions, "...[it] resulted from the need for an efficient method of recoating building facades."<sup>155</sup> The official history credited the pioneering American taxidermist Carl Akeley with the development of the Cement Gun machine in 1907.<sup>156</sup> The resulting spray Stucco machine was an experiment to repair the deteriorated exteriors of the Field Museum of Natural History built for the World Exhibition in 1892 at Jackson Park, Chicago, in 1907.<sup>157</sup> After a trial and error process, on June 24<sup>th</sup>, 1907, Akeley presented a rudimentary double-chamber machine called 'Plastergun' that used compressed air to spray colored plaster through a hose.<sup>158</sup> Water was added through a separate hose in the nozzle to complete the process. The machine has a gasoline motor and became the prototype for the Dry-mix gun machine.<sup>159</sup> The experiment was a success, and the machine worked applying a ¼ inch coat on the outer wall of the Museum.<sup>160</sup> Still, the stucco eventually faded off the building. There was poor or little knowledge of surface preparation requirements and suitable components for the mixtures. Other applications for the machine also represented an issue, which would be solved in the following years.<sup>161</sup>

Even though the machine was initially used to repair lime stucco coating, as I. L. Glassgold mentions, "...the Shotcrete era in concrete began with the introduction of the cement gun to the construction industry at the [first] New York Cement Show in the Madison Square Garden, in December 1910."<sup>162</sup> Between 1908 and 1909, Akeley perfected the 'Plastergun' and applied for a series of patents issued in February and May 1911.<sup>163</sup> The patent from May 1911 described the original fine aggregate dry-mix proportions for the mixture composed of 1-part cement to 3 parts sand. However, it seems these proportions leaned to a weaker material, and other ratios such as 1:4 and 1:5, with

the occasional addition of lime, were considered.<sup>164</sup> That same year, the Cement Gun Company was incorporated.<sup>165</sup>

The Cement Gun was a success and caught the attention of the industry. A series of advertisements outlined the novel technology attributes as “inexpensive, [and for] continuity, flexibility, homogeneous application, and greater density than normal concrete or stucco.”<sup>166</sup> In 1911, the National Association of Cement Users (today the American Concrete Institute -ACI) published the earliest study on Guniting (dry-mix).<sup>167</sup> The testing process started among industry organizations, the private sector, and the federal government. For example, the federal government tested the Cement Gun on the newly acquired territories/colonies as early as 1911. As the laboratory sites for new ideas and inventions, between 1911 and 1914, tests with Cement Gun machine in the Panama Canal and Hawaii are documented. The Cement Gun was introduced in Puerto Rico around 1914.<sup>168</sup> A 1917 article featured the Cement Gun use in Los Angeles recommended a mixture of 1 part Portland cement, four (4) parts sand, and 10 % hydrated lime and a ‘small amount of hemp fiber’ as it worked for warmer regions.<sup>169</sup> Coatings of 1 ½ inch or 2 inches were recommended on the exteriors.<sup>170</sup>

In 1912 the word ‘Guniting’ emerged to describe the “sand-cement product of the Cement Gun,” which later in the twentieth century became the terms ‘pneumatically placed mortar,’ ‘pneumatically applied mortar,’ or ‘sprayed mortar.’<sup>171</sup> In the early years, Shotcrete was marketed as an economically viable technology that provided a waterproof, denser, and finer mixture for any desired thickness. Still, as a 1912 article mentions, one of the practical changes that Shotcrete brought was:

“Formerly, in applying cement coatings, it was necessary to erect forms and pour the material. This process was expensive not only on account of the necessity for erecting forms but also because of the fact that it was usually necessary to place more material than was required for the protection of the

surface being treated. This expense and inconvenience is eliminated by the use of the cement gun."<sup>172</sup>

Despite a great start, it was the period between 1916 and the 1920s that shaped the technology for the rest of the twentieth century. Engineer Samuel W. Traylor, President of Traylor Engineering & Manufacturing Co. of Allentown, PA, bought the rights of the Cement Gun Company in 1916. The Company was on the verge of bankruptcy for various reasons, including poor marketing and product failures, leading to a deplorable reputation in the industry between 1913 and 1918. Traylor reorganized the company and started an aggressive sales and marketing strategy to save the Cement Gun machine and the company. Aided from the profits of World War I, the marketing strategy included a significant number of advertisements, articles, and other promotions on trade journals and the establishment of the Cement Gun Company Bulletin, which had specifications and testimonials of satisfied customers. The plan included featuring new uses of the Cement Gun, besides the application of Portland cement stucco, including repairs and furnace linings applications.<sup>173</sup> Eventually, the scheme worked. Engineering literature of the late 1910s and early 1920s provides an overview of the applications of Shotcrete or 'Gunitite' in the era such as stucco coatings overall type of exterior masonry and wood frame buildings, replacement of hand-placed mortars, fireproofing of structural steel, repair of concrete bridges, bridges, sea walls, partition walls, canals, aqueducts, tunnel linings, refractory linings, bunkers, dams, among other many applications.<sup>174</sup> In this era, the Company also secured its monopoly over the Cement Gun machine, which lasted over the first half of the twentieth century.<sup>175</sup>

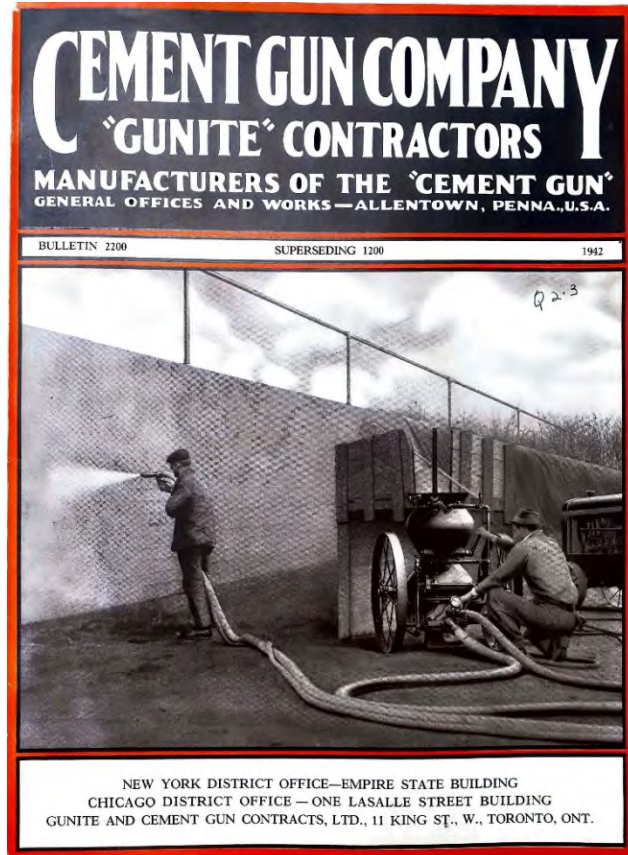


Fig. 3.34 – Cement Gun Company Bulletin issue from 1942. Source: Henry Klumb Collection, AACUPR.

The 1920s brought the golden era of Shotcrete as the machine was increasingly used in the U.S. and internationally. The Cement Gun Company experienced notable growth in sales, and research regarding Gunitite/Shotcrete increased. 20 technical papers published between 1911 and 1918, grew to around 50 published between 1921 and 1930.<sup>176</sup> The market demanded more Gunitite, and despite the rigid patents, other companies formed to produce similar machines such as the Hodges Electric Stucco Machine from 1925, which marketed the application of Gunitite as 'Gunitcrete' and 'Pneucrite.'<sup>177</sup> By 1922, Shotcrete was used globally, for example, the Company moved to patent the Dry-mix process and the machine in Germany.<sup>178</sup> However, skepticism toward the use of the Cement Gun continued as a 1921 article mentions:

“Portland cement stucco shot with a cement gun onto wire lath is another method of covering the outside of house walls. It has been used in two or three places with success. The difficulties attending the use of the cement gun are such that it is not probable this method of placing stucco will come into general use.”<sup>179</sup>

Performance testing was essential for the credibility of the Cement Gun as reliable technology in the industry. Focused on showing the superiority of Shotcrete over traditional Concrete, studies and testing over the next decades targeted its physical characteristics such as compressive, flexural, and tensile strength, bonding, permeability, shrinkage, density, soundness, and uniformity.<sup>180</sup>

The 1920s scientific advances included the standardization of the Dry-mix process and a series of experimental standards presented at the ACI's 1922 conference.<sup>181</sup> The standardized formulas or mixtures coined in the 1920s for Shotcrete are similar to present-day Shotcrete standards. Aggregate gradation has not changed at all, and heavy and lightweight aggregates were also specified. One of the significant differences is how fine aggregate with silica was recommended early and later substituted by non-quartz aggregates.<sup>182</sup> Furthermore, knowledge of surface preparation considerations before the application of Shotcrete was acquired in this decade.

Recommendations for finishing Gunite stucco usually highlighted a ‘flat, smooth or plain coat or finish,’ which could be achieved using the same floating tools as hand-applied Portland cement stucco.<sup>183</sup> Marketing materials outlined the benefits of the Cement Gun machine as an effortless and time-saving technology. Gunite stucco was showcased as a stronger, “very dense and impervious” material than concrete or hand-applied stucco and a medium to make a property “permanent, everlasting, [that can] add greatly to its value.”<sup>184</sup>

After a successful decade and a boom in new companies selling Cement Gun machines, in the early 1930s, a new term -Shotcrete- was coined by the American Railway

Engineering Association (AREA) to provide a general definition for all gunite applications besides Stucco work.<sup>185</sup> Its popularity continued to rise at the time; since Shotcrete was superior in strength to concrete, it was marketed as a 'free maintenance material,' and the machine and mixture ingredients were easily transported.<sup>186</sup> However, the 1930s brought one of the major changes to the technology when repairs such as the strengthening of dams, waterproofing, and other engineering-related applications slowly displaced Stucco from being one of the principal uses for Shotcrete.<sup>187</sup>

After four decades of success, some historians point out that since the mid-1940s, Shotcrete entered a period of "demise," which led to a revival of the technology.<sup>188</sup> The invention of a 'rotor-type continuous-feed gun' or rotary gun for dry mixes represented a great change from the double chamber system that dominated the market from 1907 through the 1940s. The invention of this new equipment allowed the inclusion of coarse and larger aggregates to mix, thus reducing costs and the amount of cement used in mixes and providing more flexibility for the use of Shotcrete in engineering applications.<sup>189</sup> On the other hand, the American Concrete Institute (ACI) established a Committee to develop Shotcrete standards known as Committee 805 for 'Pneumatically placed mortar.' Although engineers rarely acknowledged concrete maintenance and repair in the literature, Shotcrete acquired its reputation as the preferred technology for concrete repairs.<sup>190</sup> Its easy use now saw Shotcrete placement and the need for minimum forms, high strength, and durability. Still, significant disadvantages such as high shrinkage, susceptibility to the nozzleman's skill, high relative porosity, and the difference in its coefficient of expansion were mentioned continuously.

Lastly, those new standards and the new and more efficient machines ultimately led to a boom of Shotcrete applications in the post-war era. Even though this can be seen as a positive development, it harmed the Shotcrete industry. As a technology that heavily



relied on workmanship, there was little or no education to workers and engineers on using the machine correctly. Full, reliable standards were not in place until 1951.<sup>191</sup>

Regardless of the demise of stucco as the principal application for Shotcrete, sprayed stucco was still used in the late 1940s and early 1950s.<sup>192</sup> From an emphasis on smooth sprayed stuccoed finishes in its earlier days, rough finishes are also mentioned continuously and recommended in the mid-century literature. One example is the development in the 1950s of the Tyrolean rough exterior finish, which was achieved by spraying colored cement onto a cement or cement-lime substrate, often used nowadays to replicate historic roughcast finishes.<sup>193</sup> The application of one-coat sprayed stucco was used, and a 1 to 1 ½ hour setting time was recommended since this era for troweling to obtain a wave-free smooth finish.<sup>194</sup>

Earlier advances with the rotary gun machine, new equipment, and the possibility of adding coarse aggregate to shotcrete mixes influenced the re-development and heavily marketing of the Wet-mix shotcrete machine since the early 1950s.<sup>195</sup> Initially conceived in the 1910s, the Wet-mix machine had a wide acceptance among the construction industry, with an estimated nearly 5000 machines manufactured and exported to every state and over 120 countries.<sup>196</sup> These machines were principally developed for plastering and stucco work and featured premixed mortars, a cost-saving innovation that aided Shotcrete to become a viable and economical application. Also, to mitigate the number of rebound issues by these new advances, lime additive to shotcrete mixes became the norm. The inclusion of iron filings to shotcrete mixes for waterproofing purposes was also common in this era.<sup>197</sup> Among the literature of the period, two specific standards became key references: the ACI 805-51 – *Standard Recommended Practice for the Application of Mortar by Pneumatic Pressure* by the American Concrete Institute in 1951, and the *Gunite*

*Specifications and Recommended Practice* by the Guniting Contractors Association of 1954.

In 1951 the ACI Committee 805 published the ACI 805-51, the first Shotcrete standard developed by the American Concrete Institute, which included only the fine aggregate dry-mix process and stucco work. Among the requirements of ACI 805-51 includes Cement Type II, clear drawings and specifications, qualifications for workers, specifications for substrate preparation, shotcrete application, finishing, and curing protection. The importance of surface preparation for the application of Shotcrete had been mentioned in some articles and specifications in previous decades. Still, since the 1950s, using bushhammering and sandblasting was heavily emphasized. The application sequence consisted of applying the Shotcrete in a uniform application over the surface from bottom to top or vice versa, at an angle, with the nozzle at 3 ft distance—defects from uneven applications, sand spots, and ‘wet’ slugs needed to be corrected quickly. Constant inspection of the works was also underlined in the standards since workmanship affected the quality of Shotcrete. Even though the use of Shotcrete was seen as an economically viable option, the need for skilled workers continued to be a disadvantage. In the dry-mix process, the nozzleman controlled air pressure, sand grading, sand moisture, and water use. Other disadvantages of Shotcrete already recognized in the 1950s were the effects of humidity and rain during the curing process, its lower density and increased porosity compared to traditional concrete, its susceptibility to cracks, its application in thin layers, and its dusty application process.<sup>198</sup> On the other hand, in 1957, the ACI established a permanent Committee on Shotcreting known as the ACI Committee 506, which would oversee Shotcrete standards' development in the upcoming decades.

In the late 1950s, the applications of Shotcrete, often referred to as the ‘Cement Gun’ process, was increasingly noted by prominent architects and engineers that used

emerging concrete technologies of the era to create new forms and spaces. A 1959 article in *The Architect's Journal* recognized this trend in which Shotcrete started to be increasingly used from Civil engineering to architectural applications.<sup>199</sup> Architects believed that Shotcrete represented the 'best of the properties of concrete' because of its fluid nature, accessible transportation, amenability for mixing, less labor, and better control properties. One of the increased applications of Shotcrete (specially wet-mix) was on thin shell roofs and structures, very popular in mid-century modern architecture.

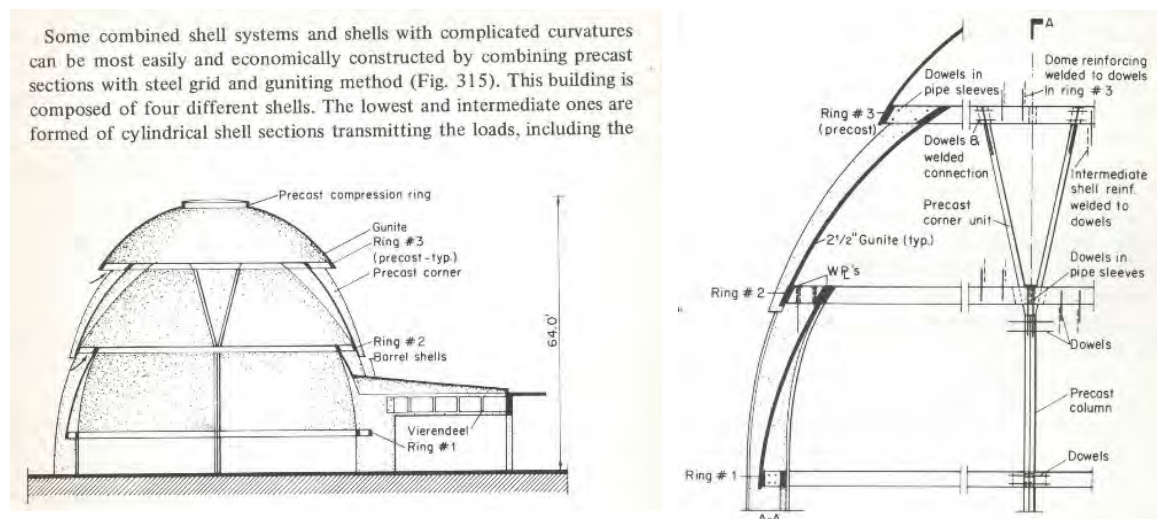
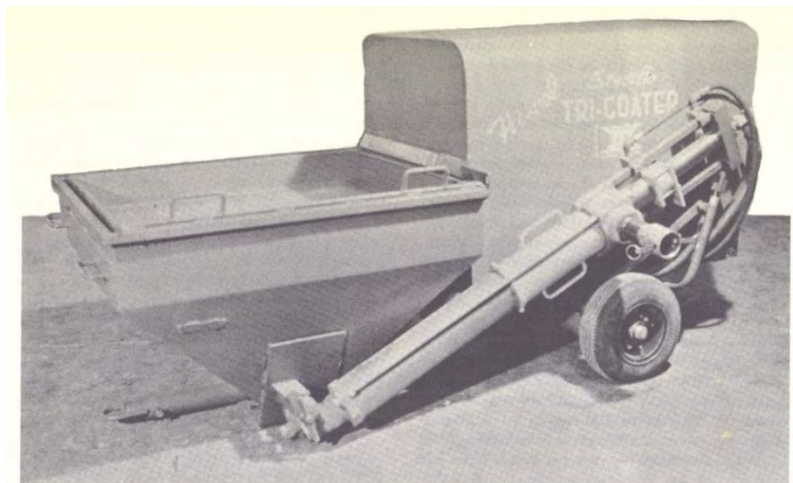


Fig. 3.35 & 3.36 – St. John's Abbey Church at St. John's University in Collegeville, MN by architect Marcel Breuer features some architectural elements in which wet-mix shotcrete was used such as the reinforced, folder, plate roof truss. Engineer A. Komendant included the use of shotcrete/gunite for developing thin shell roofs at the Del Carmen Church's first proposals. Source: Saint John's Abbey Church: Conservation, Restoration Preservation, Getty Foundation-Keeping it Modern: Planning, Final Report (July 2016), p. 135 & A. Komendant, *Contemporary Concrete Structures* (McGraw-Hill) 1972, p. 501-504.

By the early 1960s, the annual production of Shotcrete in the U.S. was estimated at over 1,000,000 cubic yards.<sup>200</sup> This era is also characterized by a boom in research led by the Portland Cement Association (PCA), which featured important articles related to the performance, mixtures, equipment, procedures, finishing, and curing of Shotcrete.<sup>201</sup> The research also sheds light on Shotcrete properties, resulting in no differences over traditional concrete. In 1966, the ACI 506 Committee on Shotcreting published its revision to the 1951 standards, including both dry-mix and wet-mix processes.

Since the 1960s, mix proportions for Shotcrete started to be done by weight basis. Typical Cement/Aggregate ratio consisted of 1:3 to 1:5 before application, which could be 1:2 to 1:4 after application due to rebound loss. As the long-term effects of the water/Cement ratio became known on Shotcrete, additional recommendations for the addition of water to mixes became relevant.<sup>202</sup> On the other hand, very fine sand was no longer recommended; instead, well-graded coarser aggregate sand was preferred.<sup>203</sup> The application of shotcrete coats for stucco was recommended in two phases and two (2) or more layers up to ¾" thick.<sup>204</sup> The inclusion of other additives to Shotcrete mixes, such as steel fibers, came one decade later.



*Fig. 3.37 –Dry-mix Plastering/Shotcrete machine in the 1960s. Source: Manual of Lathing and Plastering by John R. Diehl, 1960.*

Once characterized in the early twentieth century for smooth finishes, Shotcrete-sprayed stucco finishes in the 1960s were often distinguished for their rough and uneven appearance on concrete surfaces. The 'natural gun finish,' characterized by its roughness and achieved by leaving the sprayed stucco undisturbed after its application, was widely recommended in both standards and trade literature. This recommendation came from practical purposes since smoothing the sprayed stucco caused bonding issues with the substrate and cracks. However, if a smooth finish was desired, specific workmanship recommendations were provided. For these particular smooth finishes, three specific types are mentioned: wood flat finishes for a granular texture, rubber float for a coarse texture, and steel trowel for a highly smooth finish.<sup>205</sup> Recommendations for protective coatings for Shotcrete to prevent moisture entry, such as hot linseed oil, were also incorporated in standards. Colored sprayed stucco was still common since it provided a uniform finish and stopped issues with hand application and color quality.<sup>206</sup> The nozzleman continued to have a crucial role in achieving a successful finish, as described by Henry L. Childe in his 1964 book *Concrete Finishes and decoration*:

“If care is not taken, the surface is liable to be patchy due to variations in the colour of the sand used, variations in the consistence of the mortar, to mortar which rebounds from the surface being blown on to work already done, or to matching one day’s work on to that done the previous day. This patchy result is however, no more noticeable than the variations in shade often to be seen in ordinary rendering [stucco].”<sup>207</sup>

In Puerto Rico, the use of Shotcrete is explicitly documented for civil engineering purposes and for finishing residential projects in the 1960s, such as in Urb. Sagrado Corazón in Cupey, where sprayed stucco was given a troweled finish.<sup>208</sup> The inclusion of rough sprayed stucco surfaces on certain parts of the Del Carmen Church followed the era trends. It also brings some questions, such as what specific type of Shotcrete was used and what procedures were followed. The assessment and forensic evaluation of all

sprayed and hand-applied stuccoed surfaces in the next chapters will shed some light on these questions.

## Endnotes

---

<sup>1</sup> In Puerto Rico, *empañetado* or *empañete* means stucco or plaster, without any difference between exterior and interior applications. *Empañetado* or *empañete* are the common words used specifically for Portland cement stucco or interior plaster in the Islands. Other traditional name used for plaster (usually for lime-based) is *enlucido* and *revoque*. Beatriz del Cueto, *Conservation Methodology for Historic Buildings-Puerto Rico & Virgin Islands: Technical Spanish-English Glossary*. Unpublished manuscript, 2007.

<sup>2</sup>Historian Berthold Burkhardt mentions that “[T]he full comprehension of the material’s design potential [was] surpassed by arguments of production economy – an important fact indeed, but often put forward as an excuse for poor design in terms of material specificity”. See Berthold Burkhardt, “A Modern Movement in Engineering: Structural Developments in Architectural History”, in *The Fair Face of Concrete: Conservation and Repair of Exposed Concrete, Proceedings International DOCOMOMO Seminar* (Eindhoven: Eindhoven University of Technology, 1997), 27.

<sup>3</sup>Julianne Wiesner-Chianese mentions that early reinforced concrete was often covered with a “facing material” such as brick, terra cotta and stucco. She also, mentions that exposed, or “fair -faced” concrete was used in factories, silos, bridges and other common industrial applications. Julianne Wiesner-Chianese, “Modern in the Mountains: An Analysis of the Structural and Decorative Concrete at Jackson Lake Lodge in Grand Teton National Park, WY” (Master’s thesis, University of Pennsylvania, 2015), 50.

<sup>4</sup> *Ibid.* 52

<sup>5</sup> The use of stucco grew in popularity up to the 1920's. As New York architect Oswald C. Hering, claimed in that era, stucco was suitable for “almost all the prevalent styles in domestic architecture. Another article from a 1908 journal mentions that “Stucco is the most widely used material for the decoration of monolithic concrete structures...” See “Improvement in Concrete Work,” *The Contract Record* 22, No. 45 (November 1908), 18.

<sup>6</sup> J. Gilchrist Wilson, *Exposed Concrete Finishes: Finishes to In-Situ Concrete*, Volume 1 (New York: John Wiley & Sons, Inc., 1964, 15.

<sup>7</sup> For a full discussion and analysis see Wiesner-Chianese, “Modern in the Mountains,” 54-57.

<sup>8</sup> *Ibid.* 61

<sup>9</sup> J. Gilchrist Wilson mentions that tooled, solutions or pastes, molded and board-market constitutes the four general types of applied concrete finishes. See Gilchrist Wilson, *Exposed Concrete Finishes*, 101-117.

<sup>10</sup> Claire Gapper and Jeff Orton mentions that both English and French plasterers opted to borrow the Italian term ‘Stucco’ when they both failed establish a term for a lime plaster mix that would require to produce a modelled interior decorative work, even though Italians used the term for decorative works without any specific recipe. Both Gapper and Orton provides a depth historical analysis of terminology of Plaster & Stucco since the 16<sup>th</sup> Century in Claire Gapper & Jeff Orton, “Plaster, Stucco and Stuccoes”, *Journal of Architectural Conservation* 17, No. 3 (2011): 7-22.

<sup>11</sup> The Portland Cement Association mentions that in some regions in the U.S. Stucco is used only for ‘factory-prepared finish coat-mixtures’. John M. Melander, James A. Farny, and Albert W. Isberner, Jr. *Portland Cement Plaster/Stucco Manual* (Skokie, IL: Portland Cement Association, 2003), 20.

<sup>12</sup> Anne Grimmer, “The Preservation and Repair of Historic Stucco,” *Preservation Briefs* 22 (Washington, DC: National Park Service, Preservation Assistance Division, 1990), 1.

<sup>13</sup> Alison Henry and John Stewart, *Practical Building Conservation: Mortars, Renders and Plasters* (Historic England, 2011), 87.

<sup>14</sup> ASTM C926-20 - Standard Specification for application of Portland Cement based plaster (West Conshohocken, PA: ASTM International, 2020), Section 3.2.23.

<sup>15</sup> Beatriz del Cueto, *Conservation Methodology... 22.*

<sup>16</sup> Even though in Puerto Rico the English word ‘Shotcrete’ is commonly used, the Spanish translation homigón/concreto proyectado/lanzado (sprayed concrete in English) is also used like in South America. Another

---

Spanish term for Shotcrete, -Torcretar- was suggested in the 1966 *Proposed ACI Standard – Recommended Practice for Shotcreting*, but the term is not used in Puerto Rico.

<sup>17</sup>In Europe, this technique is often recognized as 'Sprayed concrete.' Also, according to the American Shotcrete Association (ASA) the term Shotcrete is both used for 'sprayed concrete' defined with a maximum aggregate size of 12-16 mm and 'sprayed mortar' composed of aggregates up to 6 mm. For the purposes of this thesis, the definition for Shotcrete presented in ACI 506R-16. See ACI 506R-16 – Guide to Shotcrete (Farmington Hills, MI: American Concrete Institute, 2016), 2. For the other Shotcrete definitions see George Seegebrecht, "The Evolution of Shotcrete Evaluation and Testing" *Shotcrete* (Fall 2017): 50, and "Definitions of Key Shotcrete Terminology", *Shotcrete Magazine* 14, No. 3 (Summer 2012): 27-29.

<sup>18</sup> T.F. Ryan, *Gunite: a handbook for engineers* (London, UK: Cement and Concrete Association & T.H. Brickell & Son Ltd., The Blackmore Press, 1973), 50.

<sup>19</sup> Herb Nordmeyer mentions that One-Coat stuccos basically combine the scratch and brown coats in one 3/8" thick single coat. The samples of shotcrete-stucco obtained from the field investigation at the Del Carmen Church, shows that its 3/8" thick. Also, he mentions that one coat stuccos are not covered in ASTM standards. Still, there have been past intents to recognize one-coat stuccos by ASTM Committee C11. For a further discussion on coats see Herb Nordmeyer, *The Stucco Book-The Basics* (Castroville, TX: Nordmeyer, LLC, 2012), 31, 110 & 181-184.

<sup>20</sup> *Introduction to Sprayed Concrete* (Hampshire, UK: Sprayed Concrete Association, 1999), 6

<sup>21</sup> ACI 506R-16 outlines the types of Shotcrete as Conventional shotcrete which includes shotcrete for Repair, Strengthening and reinforcing, Ground support and Linings and coatings. Other types include Refractory shotcrete, Special shotcrete and Fiber-reinforced shotcrete. ACI 506R-16 – Guide to Shotcrete... 4.

<sup>22</sup> Grimmer, "The Preservation and Repair..." 1.

<sup>23</sup> In a study conducted by the Portland Cement Association after major Hurricanes hit Central Florida in 2004, found that if installed according to standard practices, a Portland cement stuccoed wall can resist water penetration at wind speeds of 110 mph and that at 155 mph (equivalent to a Category 4 Hurricane) a ½ inch stucco was fairly resistant to moisture penetration. Stucco and Moisture resistance, "Performance of Stucco," Portland Cement Association (PCA), accessed on July 8<sup>th</sup>, 2020, <https://www.cement.org/learn/materials-applications/stucco/performance-of-stucco>

<sup>24</sup> The reviewed projects from 1957 through 1967 are: Condominio San Martín, Santurce (November 26, 1957), IBM Office Building for the San Juan Real Estate Corp. (Santurce – Feb-Jul 1958), Serra Office Building, Santurce (June 10, 1958), The Cerezal Homes, Rio Piedras (August 8, 1959), Benitez Mountain Cottage, Jajome (April 21, 1961), The Dominican Seminary, Hato Tejas, Bayamón (Nov 6, 1961), UPR Law School Expansion (1961), Aponte Residence / René Aponte House (1964), The Jacques Dreyfuss House, San Francisco, Río Piedras (June 1, 1965), Bueno House Addition & Punta Las Marias, Santurce (March 28th, 1967). Additionally, a General Cement Finishes Specifications was also consulted as part of this research. All these projects can be found at the University of Puerto Rico Architecture and Construction Archives (AACUPR), Henry Klumb Collection.

<sup>25</sup> Construction documents usually specified the use of retarding compounds such as "Rugosol" by SIKA Chemical Corp Material, and Liquid Bonding Agents such as "Hornbornd" manufactured by the A.C. Horn Companies or "Thorobond" manufactured by Thoro System Products.

<sup>26</sup> At the UPR Law School Project (1961) the "Cement Plaster Finish" was specified for 1-part Portland cement, 1-part hydrated lime, 6-parts sand by volume. *Technical Specifications UPR Law School Expansion* (1961). HKL Serie: Especificaciones, Subserie: Proyectos, File 29.27, Henry Klumb Collection, AACUPR.

<sup>27</sup> The UPR Law School Project specified the addition of chemical or mineral plasticizers for sprayed machine applied stucco. Ibid.

<sup>28</sup> Ibid.

<sup>29</sup> *Technical Specifications: Concrete and Cement Finishes*, 4. HKL Serie Especificaciones/Specifications, Subserie General, Folder 82.2, Henry Klumb Collection, AACUPR.

<sup>30</sup> For the UPR Law School project the proportions of both the Stippled and highlighted stippled finishes included 2-parts white Portland cement, 2-parts hydrated lime, 5-parts white sand, water and chemical plasticizers. See *UPR Law School Expansion...* Section 090-0, 3.

<sup>31</sup> Ibid.

<sup>32</sup> "8-04 Waterproof Cement Plaster Finish," *Technical Specifications Dominican Seminary, Hato Tejas, Bayamon, Puerto Rico*, Dominican Seminary Building C (Nov 6, 1961), 11. Henry Klumb Collection, AACUPR.

<sup>33</sup> The construction documents the specifications for the Bonding coat consisted of "1-part Portland cement and 1-part metallic aggregate by weight, mixed with sufficient water to produce a grout of brushable consistency."

---

For the Plaster coat consisted of “1-part Portland cement, 2 parts fine aggregate by weight and 25% by weight of the cement of metallic aggregate mixed with the minimum water required for a workable consistency.” See *Technical Specifications for the construction of the IBM Office Building – for the San Juan Real Estate Corp., Santurce, Puerto Rico*, (Feb 27, 1958 – Jul 22, 1958), 7-03 Method and Workmanship, 4. HKL Serie: Correspondencia, Subserie Proyectos, IBM Office Bld. Technical Specifications, Folder 27.3, Henry Klumb Collection, AACUPR.

<sup>34</sup> See 6 - Concrete Work in Henry Klumb, AIA Architect, *Technical Specifications for the construction of the Del Carmen Church at Cataño, Puerto Rico* (The Office of Henry Klumb, February 21, 1961), 8.

<sup>35</sup> In all construction documents Klumb used the term ‘plaster’ for both exterior and interior applications.

<sup>36</sup> Henry Klumb, AIA Architect, *Technical Specifications for the construction of the Del Carmen Church at Cataño, Puerto Rico* (The Office of Henry Klumb, February 21, 1961).

<sup>37</sup> “Stucco,” Portland Cement Association (PCA), accessed on July 8<sup>th</sup>, 2020, <https://www.cement.org/cement-concrete-applications/paving/buildings-structures/concrete-homes/products/stucco>

<sup>38</sup> “ACI 524R– Guide to Portland Cement Plastering,” *ACI Materials Journal* (Farmington Hills, MI: American Concrete Institute, Jan-Feb 1993).

<sup>39</sup> Contemporary mixes of stucco can use Portland cement alone or in combination with other hydraulic cements such as air-entraining portland cement, masonry cement, blended cements, plastic cement, colored cements, with different proportions.

<sup>40</sup> The Portland Cement Association mentions that traditionally stucco that is applied to masonry substrates in placed in two coats that total 3/8 inch of thickness. Still, stucco sections range from 3/8 to 7/8 inch and individual coats can be only of 1/8 inch thick. See Melander, Farny, and Isberner, *Portland Cement Plaster... 22*.

<sup>41</sup> The first two coats have specific names – scratch or *pricking up coat* and brown or *floating coat*. Since only two coats are often applied to masonry substrates, only a scratch and finishing coats are used. See Swanke Hayden Connell Architects, *Historic Preservation Planning & Estimating* (Kingston, MA: R.S. Means Company, Inc., 2000), 364.

<sup>42</sup> Materials FAQs, “Stucco Frequently Asked Questions,” Portland Cement Association (PCA), accessed on July 8<sup>th</sup>, 2020, <https://www.cement.org/learn/materials-applications/stucco/stucco-frequently-asked-questions>

<sup>43</sup> Henry Cowan and Peter R. Smith, *The Science and Technology of Building Materials* (New York, NY: Van Nostrand Reinhold, 1988), 116

<sup>44</sup> Also, since it is important to control the amount of gypsum in this early phase of the process since when water is added, the hydration of gypsum produces calcium sulfoaluminate or ettringite, which expand in the binder and can produce cracking in the stucco or concrete. See Fred Moavenzadeh, ed., *Concise Encyclopedia of Building Materials* (Exeter, UK: BPC Wheatons Ltd, 1990), 75 & *Ibid.*

<sup>45</sup> *Ibid.*, 115

<sup>46</sup> Jeremy P. Ingham, *Geomaterials Under the microscope: A Colorful Guide* (Boca Raton, FL: CRC Press-Taylor & Francis Group, LLC/Manson Publishing, 2011), 152.

<sup>47</sup> Ingham also mentions that unhydrated and partially hydrated clinker phases can also aid to identify modern cements from historic cements with optical microscopy. As an example, modern cements have small residual grains, some medium sized grains (20-60 µm) and almost no large grains, compared with Pre-1950s cements which are coarsely ground and have large cement grains (>100 µm). *Ibid.*, 82

<sup>48</sup> Even though it is widely recognized that White Portland cement does not have different properties than the ordinary Portland cement, Ashurst mentions that “Traditionally, the strength of white cement was rather less than the strength of ordinary Portland cement.” See John Ashurst, *Mortars, Plasters and Renders in Conservation*, (RIBA Publications Ltd, 1983), 29.

<sup>49</sup> These classifications made by ASTM are based mostly based on performance, not composition. Also, 90% of all Portland Cement in the U.S. is Type I. Moavenzadeh, ed., *Concise Encyclopedia... 75*.

<sup>50</sup> *Ibid.*, 502

<sup>51</sup> Melander, Farny, and Isberner, *Portland Cement Plaster... 8*.

<sup>52</sup> *Ibid.*, 9

<sup>53</sup> ASTM C926 Standard Application of Portland Cement-Based Plaster establishes the recommended mix proportions for Stucco by coats. These are: Scratch coats – 1-part cement, 2 ¼ to 4 parts sand; Brown coats – 1-part cement, 3 to 5 parts sand, & Finish coats – 1-part cement, 1 ½ to 3 parts sand. See ASTM C926-20 Standard Specification for application... 4-5

<sup>54</sup> N. Banthia, “Sprayed concrete (Shotcrete),” in Sidney Mindess, *Developments in the Formulation and Reinforcement of Concrete*, 1<sup>st</sup> ed. (Duxford, UK: Woodhead Publishing, 2008), 99.



- 
- <sup>55</sup> Melander, Farny, and Isberner, *Portland Cement Plaster...* 39.
- <sup>56</sup>Some of these special common cements are Portland-limestone cements, Ggbs and Portland blast furnace cements, fly ash and portland pozzolanic cements, high alumina cements and supersulfate cement, among others. Alan B. Poole and Ian Sims, *Concrete Petrography: A handbook of investigative techniques*, 2<sup>nd</sup> ed. (Boca Ratón, FL: CRC Press-Taylor & Francis Group, LLC, 2016), 131
- <sup>57</sup>Ibid., 253-254
- <sup>58</sup>As defined by the Portland Cement Association, a Plasticizer is “an additive that increases the plasticity of a portland cement plaster [stucco]. Plasticizing agents include hydrated lime or lime putty, air-entraining agents, organic additions and fine ground or processed inorganic substances.” Melander, Farny, and Isberner, *Portland Cement Plaster...* 41.
- <sup>59</sup> Hydrated lime and other plasticizers should be used only with normal Type I Portland Cement since other types of cements have already plasticizers. Ibid., 20.
- <sup>60</sup> Hydrated lime is defined by the Portland Cement Association as the “product manufactured by heating limestone until carbon dioxide is removed, thus forming quicklime (calcium and magnesium oxides), subsequently hydrated using water additions. Hydrated lime processing involves pressure hydration, atmospheric hydration, or slaking.” Ibid., 41.
- <sup>61</sup> Yvonne Dean, *Mitchells’ Building Series Materials Technology* (Essex, UK: Addison Wesley Longman Limited/Antony Rowe Ltd, 1996), 28.
- <sup>62</sup> C207 defines Type S as a special hydrated lime for masonry purposes, while Type SA is a special air-entraining hydrated lime. See ASTM C207-18 – Standard Specification for Hydrated Lime for Masonry Purposes (West Conshohocken, PA: ASTM International, 2018), & ASTM C206-14 – Standard Specification for Finishing Hydrated Lime (West Conshohocken, PA: ASTM International, 2014).
- <sup>63</sup> John H. Pye, Chapter 53 – “Shotcrete” in J. Lamond and J. Pielert Eds., *STP- 169D – Significance of Tests and Properties of Concrete and Concrete-Making Materials*, (May 2006), 619.
- <sup>64</sup>*Concrete Data on Master Builders Products for Improving Concrete*, 4<sup>th</sup> Ed., (Cleveland, OH: Master Builders Co., 1961), 147-148
- <sup>65</sup> Michael T. Kubal mentions the use of iron filings for waterproofing purposes as ‘one of the oldest methods’ which was patented in 1906. On the other side, both I. L. Glassgold and Anne T. Sullivan mentions the use of iron filings as additives for wet mixes prior to WWII. See Michael T. Kubal, *Construction Waterproofing Handbook*, (New York, NY: McGraw-Hill, 2000), 2.26; I. L. Glassgold, *SP 128-19 Shotcrete in the United States: A Brief History* (American Concrete Institute, 1991), 301 & Anne T. Sullivan, “Shotcrete” in Thomas C. Jester, ed., *Twentieth Century Building Materials-History and Conservation*, 2<sup>nd</sup> Ed. (Los Angeles: Getty Conservation Institute, 2014), 71.
- <sup>66</sup> Michael T. Kubal mentions that there are four specific cementitious waterproofing systems: metallic, capillary systems, chemical additive systems and acrylic modified systems, all based using Portland cement, sand and an ‘active waterproofing agent.’ The metallic system uses iron filings. Kubal, *Construction Waterproofing...*2.26.
- <sup>67</sup> Ibid.
- <sup>68</sup> Robert D. Eckhouse, *The Wise Handbook of Masonry and Waterproofing* (New York, NY: WM. H. Wise & Co., Inc., 1952), 184.
- <sup>69</sup> Ibid., 160-161
- <sup>70</sup> Kubal, *Construction Waterproofing...*2.29
- <sup>71</sup> See F. Adeyemi Olutoge, M. Attah Onugba & A. Ocholi, “Strength Properties of Concrete Produced with Iron Filings as Sand Replacement,” *British Journal of Applied Science and technology* 18, No. 3 (Jan 2017); A. Alzaed, “Effect of Iron Filings in Concrete Compression and Tensile Strength” *International Journal of Recent Development in Engineering and Technology* 3, No. 4 (Oct 2014): 121-125; Mohammed Noori Hussein AL-Hashimi & Wisan Abdullah Najim, “Performance of Concrete Containing Iron Fillings” *Journal of University of Babylon for Engineering Sciences* 26, No. 6 (2018): 384-392; M.O. Yusuf, “Microstructure and strength of iron-filing Portland cement paste and mortar” *Magazine of Civil Engineering* 90, No. 6 (2019): 28-36; Satyaprakash, Pashtoon Helmand, & Shiha Saini, “Mechanical properties of concrete in presence of iron filings as complete replacement of fine aggregates” *Materials Today: Proceedings* 15 (2019): 536-545.
- <sup>72</sup>After an analysis of diverse standards, the American Society for Testing and Materials, the Portland Cement Association and the American Concrete Institute use the same water specifications for concrete or stucco.
- <sup>73</sup> Dean, *Mitchells’ Building...*23
- <sup>74</sup> Moavenzadeh, ed., *Concise Encyclopedia...* 76.
- <sup>75</sup> Ibid., 76-77.

- 
- <sup>76</sup> ACI 506R-16 – Guide to Shotcrete... 15.
- <sup>77</sup> Ibid.
- <sup>78</sup> Ryan, *Gunite: a handbook*... 42.
- <sup>79</sup> Standards for Installation of Plaster, “Stucco Installation Standards,” Portland Cement Association (PCA), accessed on July 8th, 2020, <https://www.cement.org/learn/materials-applications/stucco/stucco-installation-standards>
- <sup>80</sup> Ibid. & ACI 506R-16 – Guide to Shotcrete... 20.
- <sup>81</sup> Bonding agents are chemical and organic compounds such as polyvinyl acetates or alcohols, cellulose derivatives, acrylic resins, or styrene butadienes. Also, Bonding agents have different chemical formulations, different performance characteristics and should conform to ASTM C932. On the other side, Bonding agents are not usually recommended for shotcrete since an improper application of the agent can act as a ‘bond-breaker’ between the stucco and the substrate. See Melander, Farny, and Isberner, *Portland Cement Plaster*... 13 & Pye, “Shotcrete” ... 619.
- <sup>82</sup> ACI 506R-16 – Guide to Shotcrete... 15.
- <sup>83</sup> Materials FAQs, “Stucco Frequently Asked Questions.”
- <sup>84</sup> ASTM C926-20 Standard Specification for application.
- <sup>85</sup> Martin Weaver provides a good overview on the importance of the Scratch’ or first layer in stuccos in Martin E. Weaver, *Conserving Buildings: A Manual of Techniques and Materials*, 2<sup>nd</sup> Ed. (New York, NY: John Wiley & Sons, Inc., ), 150.
- <sup>86</sup> Melander, Farny, and Isberner, *Portland Cement Plaster*... 21.
- <sup>87</sup> Pye, “Shotcrete”... 622.
- <sup>88</sup> Ibid., 619.
- <sup>89</sup> David Odgers, ed., *Practical Building Conservation: Concrete*, (London, UK: English Heritage, 2012), 57.
- <sup>90</sup> Even though the dry-mix systems and the wet-mix systems are recognized by the industry, Herb Nordmeyer mentions a third system known as the ‘Wheelbarrow system’ which uses a wheelbarrow “to transport the stucco to the gun and the gun is dipped into the wheelbarrow to fill it, or a shovel is used to fill the hopper for the gun.” For a complete discussion of these three systems see Nordmeyer, *The Stucco Book*... 181-189.
- <sup>91</sup> Ryan, *Gunite: a handbook*... 50.
- <sup>92</sup> Nordmeyer, *The Stucco Book*... 189.
- <sup>93</sup> ACI 506R-16 – Guide to Shotcrete... 2.
- <sup>94</sup> The crew consists of one worker on the mixer/pump area, a worker as backup which will move the delivery hose, and the nozzleman which leads the process. Nordmeyer, *The Stucco Book*... 187.
- <sup>95</sup> Ryan, *Gunite: a handbook*... 33.
- <sup>96</sup> ACI 506R-16 – Guide to Shotcrete... 5.
- <sup>97</sup> The American Shotcrete Association defines Impact Velocity as the “...velocity of the material particles at impact on the receiving surface. (Ideal at 350 to 400 ft/s [106 to 122 m/s]).” See “Definitions of Key Shotcrete Terminology,”... 28.
- <sup>98</sup> James Warner, “Understanding Shotcrete-The Fundamentals,” *Concrete International* (May 1995): 59.
- <sup>99</sup> “Definitions of Key Shotcrete Terminology,”... 28.
- <sup>100</sup> Guides and standards such as ACI 506R-16, ACI 308, ASTM C171, ASTM C1315 and ASTM C309 provides detailed specifications on curing processes for concrete and stucco.
- <sup>101</sup> Melander, Farny, and Isberner, *Portland Cement Plaster*.
- <sup>102</sup> “Stucco,” Portland Cement Association (PCA). Website.
- <sup>103</sup> Ryan, *Gunite: a handbook*... 41 & Sullivan, “Shotcrete” ... 73.
- <sup>104</sup> ACI 506R-16 – Guide to Shotcrete... 35.
- <sup>105</sup> In a special issue of *Progressive Architecture* journal which focused on Concrete Technology in USA, architectural historian Ada Louise Huxtable mentions that even Frank Lloyd Wright critiqued concrete as a material with “neither song nor story; nor is it easy to see in this conglomerate a high esthetic property, because in itself it is amalgam, aggregate, compound.” See Ada Louise Huxtable, “Historical Survey”, *Progressive Architecture* (October 1960): 144.
- <sup>106</sup> Ibid., 149
- <sup>107</sup> John R. Diehl, *Manual of Lathing and Plastering*, 2<sup>nd</sup> Ed., (New York, NY: MAC Publishers Association/Gypsum Association, 1965): 27.

---

<sup>108</sup> Sara Jane Stratte, “An Evaluation of Historic Cement Stucco Using Conditions Assessment Methodology and Digital Visualization Tools, Grand Teton National Park, USA,” (Master’s thesis, University of Pennsylvania, 2018), 13.

<sup>109</sup> Ibid.

<sup>110</sup> Ada Louise Huxtable mentions the complains about the deterioration of Portland cement stucco by Ernest Ransome in 1912. See Louise Huxtable, “Historical Survey...” 149.

<sup>111</sup> In STP-663 – *Cement Standards-Evolution and Trends* published in 1978, a series of authors provides an in-depth historical overview of the historical development of scientific knowledge on Portland cement in the first half of the 20<sup>th</sup> century in the U.S. In the early 1900s basic Portland cement knowledge was readily obscure. For example, principles of water/cement ratio were not well understood and not clearly outlined until 1918, there was no knowledge on the effects of aggregate gradation and compaction on concrete, attention to strength considerations began in 1916, and there were issues with accuracy and precision of testing until guidelines were established in 1925. See P.K. Mehta, ed., STP-663 – *Cement Standards-Evolution and Trends*, ASTM Special Technical Publication 663 (Philadelphia, PA: American Society for Testing and Materials, 1978).

<sup>112</sup> See Verhosek, “Characterization and Assessment...” 29.

<sup>113</sup> Cowan and Smith, *The Science...* 113.

<sup>114</sup> A. Henry and J. Stewart, *Practical Building Conservation...* 20.

<sup>115</sup> Grimmer, “The Preservation and Repair...” 3.

<sup>116</sup> In the early 20<sup>th</sup> century ‘Overcoating; became a common practice among homeowners that sought to renew or ‘enhance’ the facades of their houses. Portland cement-based, lime-based or magnesite-based Stucco was often applied to old wood frame or masonry buildings. Before the application process, the exteriors must be painted or waterproofed and must had a metal lath. See W.S. Lowndes, *Plaster and Plastering*, (Philadelphia, PA: David McKay Company, 1924), 38; The Atlas Portland Cement Company, *The Stucco House: A Book for those about to build- Owner, Architect, Builder*, (New York, NY: The Atlas Portland Cement Company, 1921), 9; & Portland Cement Association, *Portland Cement Stucco Surfacing*, (Portland Cement Association, 1927), 22.

<sup>117</sup> “Popularity of Stucco,” *Concrete - Cement Age* 7, No. 4, (Oct 1915): 131.

<sup>118</sup> Grimmer, “The Preservation and Repair...”14.

<sup>119</sup> The Atlas Portland Cement Company, *Color Tones in Stucco*, (New York, NY: The Atlas Portland Cement Company, 1917), 3.

<sup>120</sup> Yael Loewenberg, “Historic Concrete Finishes 1900-World War II,” (Master’s thesis, Columbia University, 1987), 29.

<sup>121</sup> Portland Cement Association, *A Manual of Concrete Masonry Construction: Concrete for Permanence*, (Portland Cement Association, 1923), 29; The Atlas Portland Cement Company, *Guide to Good Stucco with Specifications*, (New York, NY: The Atlas Portland Cement Company, 1916), 7; & Atlas Portland Cement Company, *The Stucco House...* 65.

<sup>122</sup> Oswald C. Hering, *Concrete and Stucco Houses: The Use of Plastic Materials in the Building of Country and Suburban Houses in a Manner to Insure the Qualities of Fitness, Durability and Beauty*, (New York, NY: McBride, Nast & Company, 1912), 11-13.

<sup>123</sup> Oswald C. Hering, *Building Concrete & Stucco Houses* (New York, NY: Robert M. McBride & Co., 1929), 34.

<sup>124</sup> Portland Cement Association, *Portland Cement Stucco Surfacing...* 6.

<sup>125</sup> Atlas Portland Cement Company, *The Stucco House...*7.

<sup>126</sup> Hering, *Concrete and Stucco Houses...* 24.

<sup>127</sup> Loewenberg, *Historic Concrete Finishes...* 28.

<sup>128</sup> On recommended color for some of these finishes the publication *Modern Modes in Better Plastering* from 1926 highlights: “*Qrecian* —white, light grays, and ivory; *Spanish* — Yellows, pinks, or white; *Italian* — Deep buffs, creams, pinks, warm red-dish hues, or soft tints, or white; *French*— Light grays, cream, or white; *English* — Soft buff, tans, or grays; *Colonial* — Light grays, or cream, and *California* — Any of the color tones suggested under Italian, or duo-tone combination color effects. See *Modern Modes in Better Plastering: Period-textured plastering is now accorded due to recognition as a great Renaissance in American Architecture*, (Milwaukee, WI: Milwaukee Corrugating Company, 1926), 21.

<sup>129</sup> Portland Cement Association, *Portland Cement Stucco Surfacing...* 4.

<sup>130</sup> Grimmer, “The Preservation and Repair...” 15, & Lowndes, *Plaster and Plastering...* 73.

<sup>131</sup> W.D.M. Allan, “Portland Cement Stucco Finishes-Report of Committee 401,” *Journal of the American Concrete Institute-Proceedings*, (1929): 38.

<sup>132</sup> Portland Cement Association, *A Manual of Concrete Masonry Construction...* 26.

---

<sup>133</sup> A 'Cold water wash' was basically the application of a fine stucco coat with pigment over the finish coat. For a specific procedure on the application of Cold water washes see *Stucco Investigations at the Bureau of Standards with Recommendations for Portland Cement-Stucco Construction-Circular of the Bureau of Standards, No. 311*, (Washington, D.C.: U.S. Department of Commerce, Bureau of Standards, Dec 1926), 33-34. Also, see Portland Cement Association, *Portland Cement Stucco Surfacing...* 5.

<sup>134</sup> Portland Cement Association, *Beauty in the Walls of Architectural Concrete*, (Chicago: Portland Cement Association, 1936), 1.

<sup>135</sup> See Allan, "Portland Cement Stucco Finishes..." 197 & 203; & Portland Cement Association, *Portland Cement Stucco*, (Portland Cement Association, 1927), 6 & 37.

<sup>136</sup> Michael A. Tomlan, "Introduction-Building Modern America: An Era of Standardization and Experimentation" in Thomas C. Jester, ed., *Twentieth Century Building Materials-History and Conservation*, 2<sup>nd</sup> Ed. (Los Angeles: Getty Conservation Institute, 2014), 4.

<sup>137</sup> Allan, "Portland Cement Stucco Finishes..." 31, & Portland Cement Association, *Concrete Masonry Construction for Enduring and Firesafe Structures: Concrete for Permanence*, (Portland Cement Association, 1935), 42.

<sup>138</sup> Henry and Stewart mention that "...the alkaline surface of fresh concrete is hostile to many paints, particularly those in popular use before 1939. In 1930 the paint manufacturers' literature recommended that cement surfaces should be allowed to carbonate for 12 -18 months before painting before painting, to reduce the alkalinity." Henry and Stewart, *Practical Building Conservation...* 30.

<sup>139</sup> W. Hebert Gibson, *Concrete Design and Construction*, 2<sup>nd</sup> ed. (Chicago, IL: American Technical Society, 1945), 357.

<sup>140</sup> J. Gilchrist Wilson, *Exposed Concrete Finishes.*, Vol 1, (London, UK: C.R. Books Limited, 1962), 11-14.

<sup>141</sup> Edward L. Friedman, "Search", *Progressive Architecture* (October 1960): 162.

<sup>142</sup> Henry and Stewart, *Practical Building Conservation...* 22.

<sup>143</sup> Henry Giese, *A Practical Course in Concrete*, (Chicago, IL: Portland Cement Association, 1948), 54.

<sup>144</sup> Hebert Gibson, *Concrete Design...*, 357-366.

<sup>145</sup> Bert A. Hall, "Crack Control in Portland Cement Plaster," *Journal of the American Concrete Institute* 19, No. 2, (Oct 1947): 129.

<sup>146</sup> J Ralph Dalzell, "Do it Yourself: Stucco Wall Cracks Repaired," *The Sun* (Baltimore: Aug 1954): 80; "Cement, Concreted Mortar and Related Products," *American Builder* 74, No. 4 (April 1952): 486; & "Stucco and Concrete Coatings," *American Builder* 75, No. 4 (April 1953): 83.

<sup>147</sup> See Portland Cement Association, *Concrete Masonry Handbook for Architects, Engineers, Builders* (Chicago, IL: Portland Cement Association, 1951), 43-45. Also, some publications in the 1950s still recommended wood floating and stonework resemblance finishing for Portland cement stucco. See "Concrete: Report A on Cement SUGGESTED CONCRETE MIXES Machines for Concrete Construction," *American Builder* 72, No. 6 (June 1950): 78; & "Cement, Concreted Mortar and Related Products," *American Builder* 74, No. 4 (April 1952): 486.

<sup>148</sup> See Joshi, ed. Corbusier's Concrete... 40. Also, some research advancements in Concrete included the introduction of air permeability tests in 1953 and the addition of alkali content as optional requirements for concrete mixes in 1959. Also, a 1950 article on the *American Builder* mentions how "too much cement or too much fine aggregate will cause crazing or checking" showing how scientific discoveries from the past decades were already framing the industry practices. See "Stucco," *American Builder*, June 1950.

<sup>149</sup> Joshi, ed. Corbusier's Concrete... 13.

<sup>150</sup> H. L. Childe, *Concrete Finishes and Decoration*, (London, UK: Concrete Publications Limited, 1964), 52.

<sup>151</sup> Diehl, *Manual of Lathering and Plastering...* 1.

<sup>152</sup> Caleb Hornbostel in *Materials for Architecture- An Encyclopedic Guide* published in 1965 mentions the following regarding Concrete finishes: "Concrete finishes may be roughly divided into two groups: (1) finishes for vertical and ceiling surfaces, applied to concrete already set; and (2) finishes for floor surfaces, applied while the concrete is still plastic and workable. Walls and ceilings may be given any of the following typical finishes: Rough finish, Smooth finish, Rubbed finish, Design finish & Plaster, stucco or cement plaster finish – Concrete that is to receive these finishes must be provided with some sort of bonding surface, For example, flexible dovetail inserts may be applied to the forms to create bonding cavities." Caleb Hornbostel, *Materials for Architecture- An Encyclopedic Guide* (New York, NY: Reinhold Publishing Corporation, 1965), 157.

<sup>153</sup> About the functionality of structural application of Stucco Diehl mentions that "...employed as primary elements of load-bearing structures in theatrical and display construction work. Traditionally, stage scenery,

---

amusement parks and expositions of various types have made wide use of plaster where the structural versatility and economy of the craft have been exploited full..." Ibid.

<sup>154</sup> Childe, *Concrete Finishes...* 52.

<sup>155</sup> Pietro Teichert "Carl Akeley- A Tribute to the Founder of Shotcrete," *Shotcrete* (Summer 2002): 11.

<sup>156</sup> In his book, Louis Rodriguez discuss how Akeley could be influenced by previous inventions in the industry such as the Sandblasting machine and the Kelly nozzle, patents which he bought after the incorporation of the Cement Gun Product Company in 1911. Also, a 1911 article published in *Cement Age* journal features the use of a 'type of cement gun' by German contractors, further evidence the Cement Gun existence probably before Akeley's invention. Louis Rodriguez, *From Elephants to Swimming Pools: Cark Akeley, Samuel W. Traylor and the Development of the Cement Gun* (Easton, PA: Canal History and Technology Press, 2006), 68 & *Tonindustrie Zeitung*, "A German Cement Gun," *Cement Age* 8, No.4 (October 1911): 175.

<sup>157</sup> Carl E. Akeley (1864-1926) was a renowned American Taxidermist, sculptor biologist and inventor distinguished by its contributions to the Field Museum of Natural History and the American Museum of Natural History. In his book, Louis Rodriguez discuss the events between Spring and June of 1907 leading to the development of the Cement Gun machine. See Rodriguez, *From Elephants...* 66-67.

<sup>158</sup> Teichert "Carl Akeley..." 11.

<sup>159</sup> "Placing Cement Coating with the Cement Gun," *The Construction News* 33, No. 3 (January 20, 1912): 16.

<sup>160</sup> Teichert "Carl Akeley..." 11.

<sup>161</sup> Rodriguez, *From Elephants...* 68.

<sup>162</sup> Glassgold, "Shotcrete..." 295.

<sup>163</sup> In February 1911, Akeley received a patent for a single chamber machine and another in May 9, 1911 for an "Apparatus for mixing and applying plastic or adhesive materials" (No. 991814).

<sup>164</sup> Glassgold, "Shotcrete..." 300 & Pye, "Shotcrete"... 619.

<sup>165</sup> Lois Rodriguez estates that in 1911 Akeley founded the company along with John E. Shepherd, Robert L. McElroy, Charles A. Cooper, Garret D. Cooper, Wallace B. Wolfe, and Worth E. Caylor. Also, he mentions that in order to prevent any lawsuits and protect the invention, they bought a series or Patents: a sandblaster apparatus (No. 773,665 and No. 783,218) invented by John D. Murray, patented in Nov. 1, 1904 and Feb. 21, 1905; sandblaster nozzle (No. 839,483) invented by William H. Kelly, patented Dec. 25, 1906; and both Akeley's patents - a process of producing and depositing plastic adhesive mixture (No. 984,254) patented Feb. 14, 1911; and an apparatus for mixing and applying plastic adhesive materials (No. 991,814), patented May 9, 1911. See Rodriguez, *From Elephants...* 68.

<sup>166</sup> William R. Lorman, "Engineering Properties of Shotcrete," *NCEL Technical Report R429 with Addendum- ACI Publication SP-14A* (Detroit, MI: American Concrete Institute, December 1968), 3.

<sup>167</sup> Pye, "Shotcrete"... 617.

<sup>168</sup> In the Panama Canal, Louis Rodriguez mentions that the Cement Gun Company forged a contract with the federal government to test the machine for one month to coat rocks and prevent disintegration. Still, the tests proved unsuccessful. In Hawaii, a report from 1913 mentions that the machine was used for a cement plaster lining. William R. Lorman confirmed the arrival of Gunitite to Puerto Rico and the other territories in his 1968 report. See Rodriguez, *From Elephants* 76; "Lining Ditches with Reinforced Concrete - Gunitite mortar," *Concrete-Cement Age* 2, No. 6 (June 1913): 265; & Lorman, "Engineering Properties..." 4.

<sup>169</sup> *The Cement Gun in Building Construction - Bulletin 114*, (Allentown, PA: Cement Gun Company, Inc.), 7.

<sup>170</sup> "Gunitite stucco," *The National Builder* 60, No. 9 (September 1918): 30.

<sup>171</sup> I.L. Glassgold estates that the 'Gunitite' term focused on cement mortar and become the earliest definition of dry-mix shotcrete. See Glassgold, "Shotcrete..." 295.

<sup>172</sup> "Placing Cement Coating with the Cement Gun," *The Construction News* 33, No. 3 (Jan 20, 1912): 16.

<sup>173</sup> For an in-depth discussion about Traylor changes in the Company see Rodriguez, *From Elephants...* 81-85.

<sup>174</sup> Pye, "Shotcrete"... 619.

<sup>175</sup> Louis Rodriguez estates that the protections of patent rights, the infancy stage of the industry, and workmanship/application complaints over Gunitite are the three specific reasons for this monopoly over the machine and technology by the Company. Rodriguez, *From Elephants...* 87.

<sup>176</sup> Glassgold, "Shotcrete..." 291.

<sup>177</sup> See *For applying Plaster-Stucco-Waterproofing*, (Cincinnati, OH: Hodges Stucco Machine Works, 1925) & I Glassgold, "Shotcrete..." 295.

<sup>178</sup> George D. Yogy, "The History of Shotcrete," *Shotcrete* (Summer 2005): 28, & Dudley R. "Rusty" Morgan, "Advances in Shotcrete Technology for Infrastructure Rehabilitation," *Shotcrete* (Winter 2006): 18.

- 
- <sup>179</sup> Leslie H. Allen, "New Materials and Methods of Construction as a Means of Reducing Costs," *The National Builder* 64, No. 2 (Feb 1921): 51.
- <sup>180</sup> Glassgold, "Shotcrete..." 302.
- <sup>181</sup> Sullivan, "Shotcrete"... 71- 72.
- <sup>182</sup> Glassgold, "Shotcrete..." 300.
- <sup>183</sup> *For applying Plaster-Stucco-Waterproofing...* 5.
- <sup>184</sup> A 1925 marketing pamphlet of the Hodges Stucco Machine mentions that machine applied stucco: "... [created] a film of water causing a skin or enamel to form, leaving a surface impervious to moisture..." something that cannot be done "... by hand application and of such merit that stucco ahead in great demand for outer construction finishes has a future trend that may be designated by leaps and bounds." See *Ibid.*, 3. Also, see "Contractors' Power Equipment: Construction Work Speeded Up and Costs Lowered by Many Appliances Useful and Profitable to the Builder," *American Builder* 37, No. 3 (June 1924): 366; & "Gunitite," *The National Builder* 66, No. 2 (February 1923): 74.
- <sup>185</sup> I.L. Glassgold estates that the original Shotcrete definition by the American Railway Engineering Association (AREA) is "[a] premixed dry Portland cement and sand pneumatically ejected from a machine through hose and a discharge nozzle where water is added, all under regulated pressure." Glassgold, "Shotcrete..." 296.
- <sup>186</sup> ACI 506R-16 – Guide to Shotcrete... 2.
- <sup>187</sup> As an example, in *Gunitite: A Handbook of Cement Gun Work* published in 1934, outlined all engineering applications such as construction of aqueducts, strengthening of early reinforced concrete, lining steel chimneys, building coal bunkers, encasement of structural steelwork for strengthening or protection, waterproofing tunnels and refacing of sea walls, dams, etc.; with no mention of Stucco/Plaster work. Similar trade literature since the 1930s barely mentioned or did not showcased Stucco as an application for Shotcrete. See *Gunitite: A Handbook of Cement Gun Work* (London, UK: The Concrete Proofing Co. LTD., 1934), 5-6.
- <sup>188</sup> See Yoggy, "The History of Shotcrete"... 29.
- <sup>189</sup> Other change is the inclusion of expanded shale to Shotcrete mixes since 1948. I.L. Glassgold mentions that despite the advancement that the inclusion of larger aggregates represented to shotcrete, it ultimately failed as "...coarse aggregate shotcrete was found to be hard on placing equipment and hoses, and in addition, the higher rebound tended to nullify some of the cement savings." See *Concrete Masonry Manual*, (Washington, D.C.: Expanded Shale & Slate Institute, 1960), 43; & Glassgold, "Shotcrete..." 300.
- <sup>190</sup> In a 1947 article published in the *Journal of the American Concrete Institute*, W.L. Chadwick stated that only few literature addressing concrete maintenance and repair, including case studies on repair works on deteriorated structures for hydraulic use (dams, control works, canals, conduits and tunnels) existed at the time. Engineers realized these issues and 'Pneumatically placed mortar' as a repair method became the possible solution. See W.L. Chadwick, "Hydraulic Structure Maintenance Using Pneumatically Placed Mortar," *Journal of the American Concrete Institute* 18, No. 5 (January 1947): 533.
- <sup>191</sup> For a list of the new types of machines and further discussion see Yoggy, "The History of Shotcrete"... 29.
- <sup>192</sup> A 1949 article published on the *American Builder* mentions: "Although construction varies, the majority of the houses are framed with redwood siding or striated plywood exteriors. Where plaster or stucco is used, increased wall strength and the elimination of plaster cracks is achieved by the use of Gunitite which has also reduced plastering time." See "Low-Cost Housing with Style and Quality Tucson AZ," *American Builder* (May 1949): 114.
- <sup>193</sup> Alison Henry and John Stewart estates that the Tyrolean mix used originally cement-based products, but later polymers were incorporated. They also mention three specific applications used for the Tyrolean finish: "...45° to the wall working from the right, 45 ° to the wall working from the left, and applied straight on perpendicular to the face of the wall." See Henry and Stewart, *Practical Building Conservation...* 92.
- <sup>194</sup> "55-Year Building Success Formula – Jetcrete." *American Builder* (October 1950): 97.
- <sup>195</sup> Pye mentions that the development of the True Gun machine and subsequent adaptations to the Wet mix process led to its widely acceptance in the 1950s. New equipment in the 1950s includes the introduction of rubber, plastic and flexible metal hoses. See Pye, "Shotcrete"... 617; & "Placing Concrete by Pumping Methods – Reported by ACI Committee 304," *ACI Journal* (May 1971): 328.
- <sup>196</sup> An article from 1914 published in *Concrete-Cement Age* feature a machine called the "Pactor" designed by Wylie G. Wilson which features the Wet-mix process. See "Pneumatic Equipment for Placing Cement Mortar," *Concrete-Cement Age* 4, No. 1 (January 1914): 45 & for the specific estimate see Yoggy, "The History of Shotcrete"... 28.

---

<sup>197</sup> An 1950 article in the *American Builder* mentions the following specifications for the inclusion of metallic filings in shotcrete: "Concrete with the proportions of 2 ½ cubic feet of sand, 1 cubic foot of cement and 30 pounds of metallic waterproofing is shot on the wall in a first coat ½ to ¾ inches thick -for a three to five- foot head. It is shot up to 1 ½ to 3 inches for a 10 to 20-ft head. After screeding and allowing to set for 8 to 12 hours, the surface is dampened and shot to an additional ½ -inch with a straight 3:1 mix and troweled off. The last step consists of plugging the bleed holes and filling them by hand with the metallic waterproofing and finish mix after the section has been allowed to set for three days." Even though the dome's stucco at the Del Carmen Church has iron filings for waterproofing purposes, instrumental analysis on Chapter 5 confirmed that shotcrete was not used in that area. See "55-Year Building Success Formula..." 214.

<sup>198</sup> "ACI 805-51 – Recommended Practice for the Application of Mortar by Pneumatic Pressure," *Journal of the American Concrete Institute* (May 1951): 711.

<sup>199</sup> "Cement Gun - Technical Section 19 CONSTRUCTION DETAILS," *The Architect's Journal* (October 22, 1959): 391.

<sup>200</sup> Estimate from the Guniting Contractors Association in 1962. See Lorman, "Engineering Properties of Shotcrete"... 4.

<sup>201</sup> This research was led by Joseph J. Shideler and Albert Litvin since around 1965. See George Seegebrecht, "The Evolution of Shotcrete Evaluation and Testing," *Shotcrete* (Fall 2017): 51.

<sup>202</sup> The Proposed ACI Standard Recommended Practice for Shotcreting from 1966 mentions that the Water/Cement ratio for Shotcrete ranged between "0.35 to 0.50 by weight, which is somewhat lower than for most conventional concrete mixes."

<sup>203</sup> Lorman, "Engineering Properties of Shotcrete"... 8.

<sup>204</sup> *Concrete Manual – A Manual for the Control of Concrete Construction*, 7th Ed. (Denver, CO: U.S. Department of the Interior, Bureau of Reclamation, 1963), 484; & Frank A. McCaughan, "Pneumatic Application of Cement-Mortar Tank Coatings," *Journal- American Water Works Association* 57, No. 9 (September 1965): 1147.

<sup>205</sup> The Proposed ACI Standard Recommended Practice for Shotcreting from 1966 provides the following workmanship recommendations: "After the surface has taken its initial set (crumbling slightly when cut), excess material outside the forms and ground wires should be sliced off with a sharp-edged cutting screed. The ground wires should then be removed. The finish may be left in this condition or it may be broomed. Where a still finer finish or better appearance is desired, a flash coat may be used. This is a thin surface coating containing finer sand than normal, and the application nozzle is held well back from the work. It should be applied to the shotcrete surface as soon as possible after the screeding." See "Proposed ACI Standard Recommended Practice for Shotcreting," *Journal of the American Concrete Institute* 63, No. 2 (February 1966): 241.

<sup>206</sup> Diehl, *Manual of Lathing and Plastering...* 118-119.

<sup>207</sup> Childe, *Concrete Finishes...* 51.

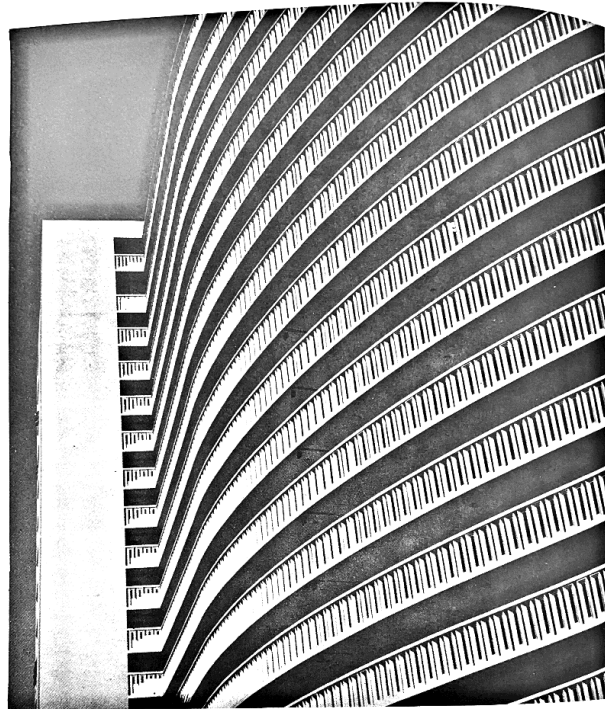
<sup>208</sup> Phone call with José 'Pepe' Izquierdo, PE, past President of the American Concrete Institute on July 8<sup>th</sup>, 2020.

## CHAPTER 4

### Del Carmen Church's Exterior Concrete Surfaces: Conditions Assessment and Current State of Conservation

#### 4.1 Purpose and scope

Until the 1970s, Portland cement and reinforced concrete were perceived as a highly durable and maintenance-free material. Portland cement's availability and relatively easy mixing and placement, especially for low skilled laborers, made it an attractive construction method. In this mindset, the consideration of protective measures such as waterproofing through detailing or protective coatings, as well as regular inspection and maintenance practices, were not common. These erroneous ideas led to a boom in concrete research during the 1970s and 1980s.<sup>1</sup>



**Bello, Seguro, Económico... y ¡LIBRE DE MANTENIMIENTO!**

Barandas de Concreto Blanco prefabricado de fácil instalación. No se ahoya, ni enmohece, ni se descolora con los rigores del tiempo. Tenemos una gran variedad en existencia pero

fabricamos su diseño si usted así lo prefiere. Llámenos o escriba hoy pidiendo nuestro catálogo y cualquiera otra información.

**CONCRETE UNLIMITED**

Box 10881 Caparra Heights Sta., P.R. Tel.: 782-7222

78 Urbe

Fig. 4.1 – “Beautiful, Safe, Economic... and Maintenance Free!” Advertisement in the early 1960s of the Concrete Unlimited Company which marketed precast concrete elements. The ad states that White prefab concrete did not ‘pit, mildew or discolor’ over time. Source: *Revista Urbe*, c.1965, AACUPR.



As defined by the American Concrete Institute (ACI) and other international organizations, concrete is a composite material that consists of a hydrated cement paste made of Portland cement and water, coarse and fine aggregates, and sometimes chemical admixtures or additives.<sup>2</sup> Henry Klumb mastered the use of concrete and cementitious materials in his projects. The Del Carmen Church, with its exposed exterior concrete and Portland cement stuccoed surfaces, presents specific challenges in restoring Klumb's original design intent as well as extending the performance life of the building. This assessment intends to answer the following questions:

- What are the current conditions of the exterior surfaces?
- How does composition, design, and construction influence the performance of aged cement stuccoed surfaces in a tropical and maritime environment?
- How have environmental conditions affected the performance and weathering of the exposed cement plaster surfaces?
- What coatings and other surface treatments have been employed to the exterior of concrete surfaces over the years?
- What alterations to the exterior surfaces have had a significant impact on the church's aesthetic integrity?

In a conservation project, not all buildings face the same issues, and situations greatly vary depending on their location. Since the range and depth of questions are diverse, not all assessments are equal. Some focus on interpreting problems within the composition of the fabric, and other assessments are done in preparation for subsequent interventions to the building. For this thesis, the selected type of assessment is a 'Building Fabric Survey' as defined by Pender, Ridout, and Curteis.<sup>3</sup> The main goals of the assessment are to identify and characterize the church's exterior surfaces, the construction and detailing of the building, and deterioration trends such as the water flow patterns, bio-growth, current failure of coatings, concrete and stucco failure, and vulnerable features that will require further investigation and testing. Lastly, the present survey looks at

alterations; previous remedial work on the building's exterior, and selected sampling areas.

## **4.2 Methodology**

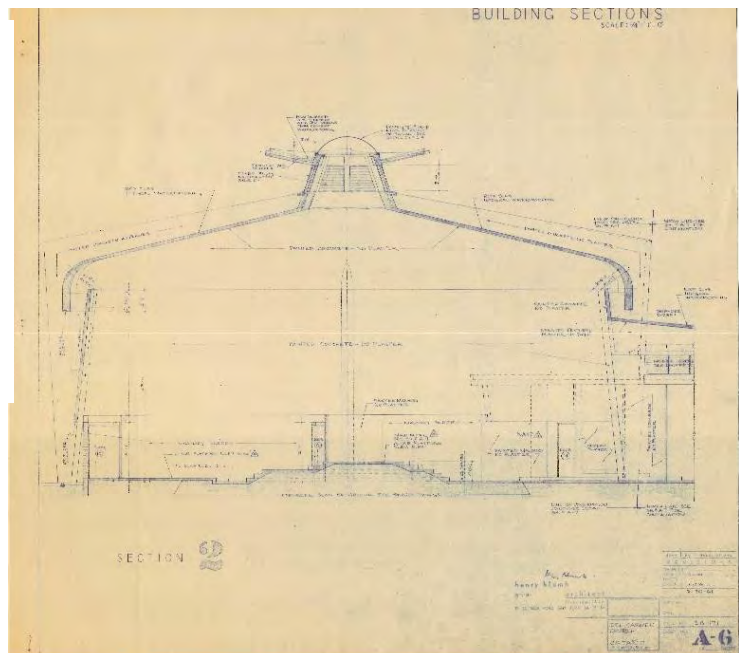
What is a Conditions Assessment? It is a holistic-technical evaluation of the conditions of a historic building, structure, or site. It aims to understand how a building was constructed, its use, maintenance practices, and what mechanisms affect its structural and material condition.<sup>4</sup> A visual assessment is the most used along with photography and notes, although there are various other methods. In this research project, the type of assessment chosen was the 'Building Fabric Survey,' a comprehensive evaluation comprised of three phases. The first phase is archival research, which includes collecting historical photographs, drawings, construction specifications, and other essential documents to provide information about the buildings' design and construction. The second phase is a building performance assessment, which includes an on-site evaluation of the building envelope to date, research on the site's climatic conditions, building use, and history of problems and interventions. Lastly, the third phase involves a specialist investigation, including material analysis, testing, and detailed monitoring. Following the *Building Fabric Survey* methodology helped to identify environmental issues, their sources, and effects on the various architectural elements of the church and the building as a whole. This chapter will concentrate on the first two phases, while Chapter 5 will cover in-depth information about material analysis and testing. All the information gathered from this survey provides valuable information about the building conditions and informs a recommended exterior conservation program.

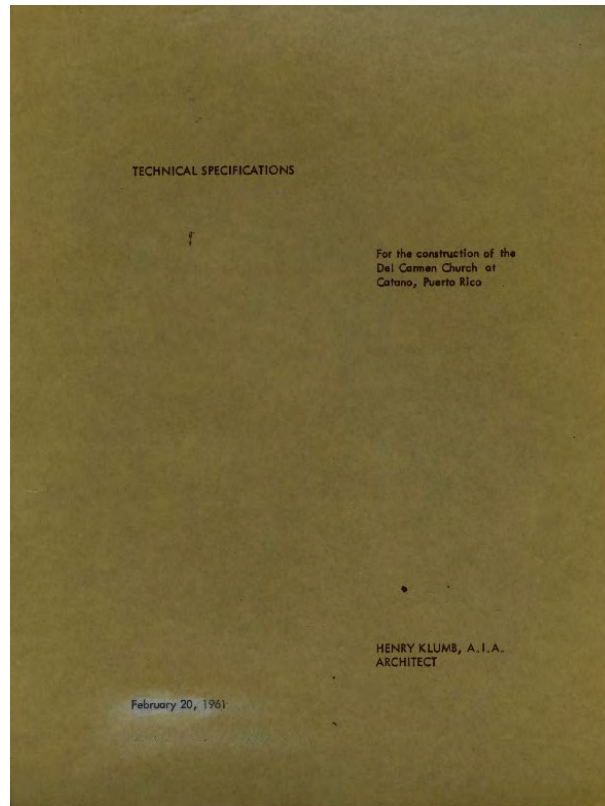
Following the outlined approach, a preliminary inspection and introductory photographic survey were undertaken at the Church on August 21<sup>st</sup>, 2019. That same week (August 18 – 20<sup>th</sup>, 2019), extensive archival research that included scanning of

drawings, construction specifications, and historical photos was undertaken at the Archivo de Arquitectura y Construcción de la Universidad de Puerto Rico/UPR Architecture and Construction Archives (AACUPR), and the Biblioteca Santiago Iglesias, Hijo de la Escuela de Arquitectura de la Universidad de Puerto Rico/UPR School of Architecture Library Santiago Iglesias, Jr. From August through December of 2019, the construction drawings, specifications, photos, and other documents from the church, were cataloged and analyzed, crucial steps for understanding the building fabric and its construction.



Fig. 4.2 & 4.3 – Archival research at AACUPR on February 2020 (top left photo) & a sample construction drawing of a section of the church by H. Klumb from 1961 (bottom right photo). Photo by E. García, 2020 & Source: AACUPR.





*Fig. 4.4* – Final construction specifications for the Del Carmen Church from February 1961. Source: Henry Klumb Collection – AACUPR.

A second visit to AACUPR on December 20<sup>th</sup>, 2019, was done to continue the archival research. On December 23<sup>rd</sup> & 24<sup>th</sup>, 2019, detailed architectural and aerial photographic surveys were executed with photographer Javier Freytes and Diana Serrano. From December 25<sup>th</sup> to mid-January, the church drawings used in this research were developed using AutoCAD and Illustrator with the original plans from AACUPR, photographs, and on-site measurements. On January 7 – 8, 2020, a literature review was conducted on references regarding conditions assessments and pathologies on concrete and Portland cement stuccoes. The first site visits, the photographic surveys, and literature helped to tailor a preliminary list of conditions of the Del Carmen Church exterior.



*Fig. 4.5 – Conducting the aerial photographic survey of the building with Diana G. Serrano Miranda on December 24<sup>th</sup>, 2019 and an aerial photo of the church facing the San Juan bay. Photos by D. Serrano Miranda, 2019.*

A full on-site investigation was done from January 9-13 and from February 11-14, 2020, following these steps:

- Filling out specifically designed Conditions Assessment Data Sheets for this project included basic information such as elevation number, date, time, temperature and relative humidity, area use, equipment used, architectural description, water disposal, among other data.
- Using an integrated approach for the assessment by first examining the surrounding area before the appraisal, then examining the wall or area from top to bottom, and horizontally clockwise, following the recommendations of B. Feilden.<sup>5</sup>
- The first considered conditions in the assessment were detached/debonded areas of stucco and concrete identified by using the Sound Hammer Test as specified in ACI 506.4R-94-*Guide for the*

*Evaluation of Shotcrete.*<sup>6</sup> The Test is performed to locate sub-surface voids and consists of tapping with a small hammer on exterior surfaces with the aid of a stepladder and white chalk to mark the affected areas.

- An evaluation of cracks, atmospheric soiling, previous repairs, biological growth, and other conditions followed.
- All conditions were drawn, and extensive notes were taken on the elevation drawings using colored pencils and markers.
- Specific photographs of different conditions per elevation were taken with the use of a scale and color checkers.
- Lastly, the photographic surveys per elevation were organized in folders.

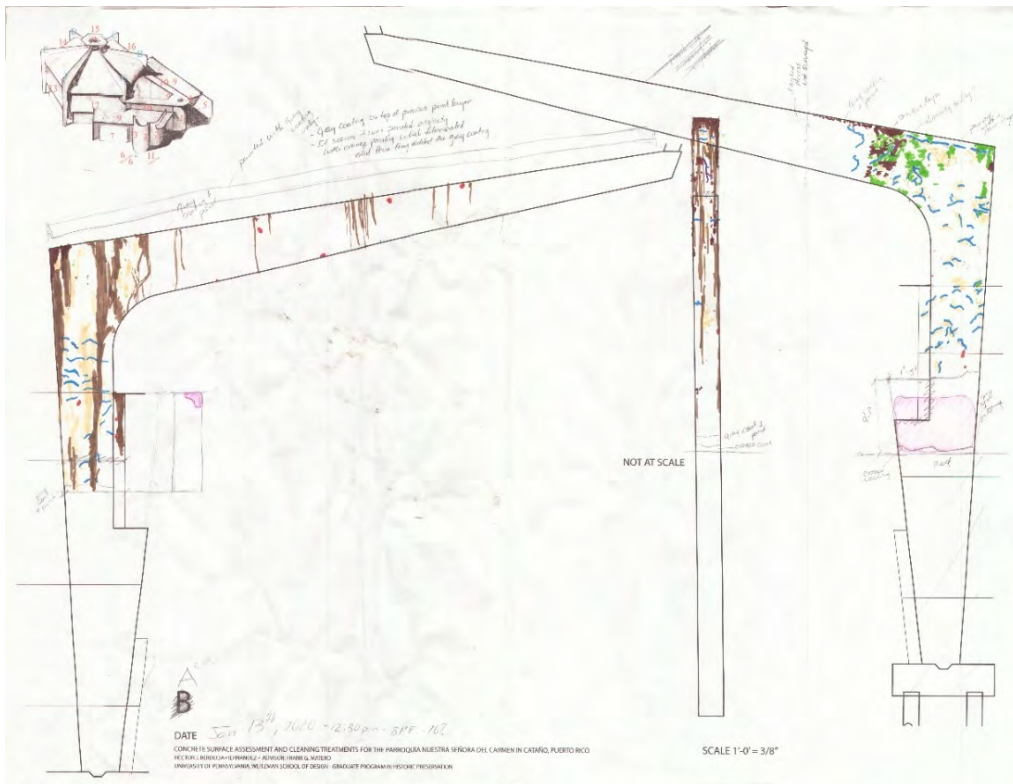
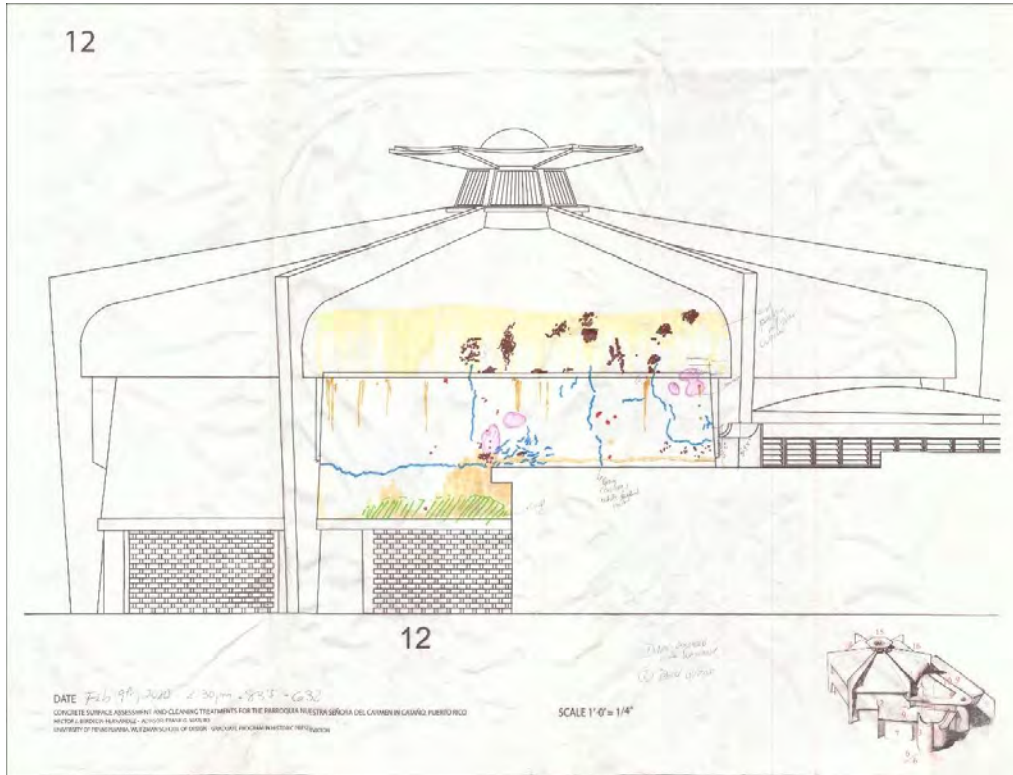


Fig. 4.6 & 4.7 – Sample elevation drawings with notes and conditions marked during the on-site assessment. Drawings by H. Berdecía-Hernández, 2020.



*Fig. 4.8 & 4.9 – Condition issues on precast wall (north side) and the stuccoed cast-in-place wall on the southeast side of the church. Photos by Author, 2020.*

As part of the on-site investigation, the following materials were used to complement the assessment: Church drawings/plans on 18" X24" sheets, a 2-page long Conditions Assessment Data Sheet, color markers, white chalks, a small hammer, a Hasting Triplet Magnifier 10x – 25 mm, color and grey cards, different cameras for the photographs and three ladders.<sup>7</sup>





*Fig. 4.10 & 4.11*– Examining the stuccoed wall on the north side of the church and meeting with E. Vivoni, architect B. del Cueto, M. Frances-Gallart & Y. Hernández, AIT on January 11<sup>th</sup>, 2020. Photos by C. Osorio & Author, 2020.

As the basis for the identification and description of the present conditions in Del Carmen Church, all terminology and qualitative descriptions comply with the standard typology of deterioration patterns identified in common literature from the field.<sup>8</sup> Please see the attached “Conditions Survey Assessment” in the Appendix for more details.

Following this process, sampling on-site was done on January 10<sup>th</sup>, 12<sup>th</sup> & 14<sup>th</sup>, 2020. A more detailed explanation of the sampling process will be featured further in Chapter 5. On January 20-23<sup>rd</sup>, 2020, the archival research continued at the University of Pennsylvania Architectural Archives, analyzing and studying the August Komendant Collection. The last visit to several archives was also done on February 11-14<sup>th</sup> which included: AACUPR, the Centro de Investigaciones Históricas de la Universidad de Puerto Rico/Center for Historic Research of the University of Puerto Rico, and the Archivo Histórico Arquidiocesano de Puerto Rico/Historical Archives of the Archdiocese of Puerto Rico in Old San Juan. After concluding the detailed assessments in February, conditions drawings were scanned. These drawings were organized in a folder. The final conditions

drawings were developed and formatted in AutoCAD and Illustrator software between May and June 2020.

### **4.3 Limitations**

The height of the building and accessibility to some areas, including the dome, was a significant limitation of this assessment. This problem also affected the accuracy of the drawings since some measurements were impossible to take by hand. The accuracy of the location of some conditions in the drawings was another issue affected by incomplete accessibility.

Another limitation was the weather. As all work was undertaken on the exterior, frequent precipitation affected the proposed schedule. However, these climatic conditions also helped identify the water management issues, as discussed later in this chapter. Lastly, the current research and assessment were limited to the exterior concrete and Portland cement surfaces only. No Interior assessment was undertaken, and specific exterior elements were not evaluated, such as clay tile/terra cotta hollow block screens, wooden doors, and plastic domes; since it was out of the project's scope.

### **4.4 Description of the concrete in the Del Carmen Church**

The Del Carmen Church is constructed of reinforced concrete structural members and masonry unit bearing and non-bearing partitions. The concrete systems are distributed in the following areas:

- *Reinforced concrete block masonry* system used on walls in the north elevation, bell tower, and internal spatial divisions. Portland cement stucco was used as a finish to all masonry walls.

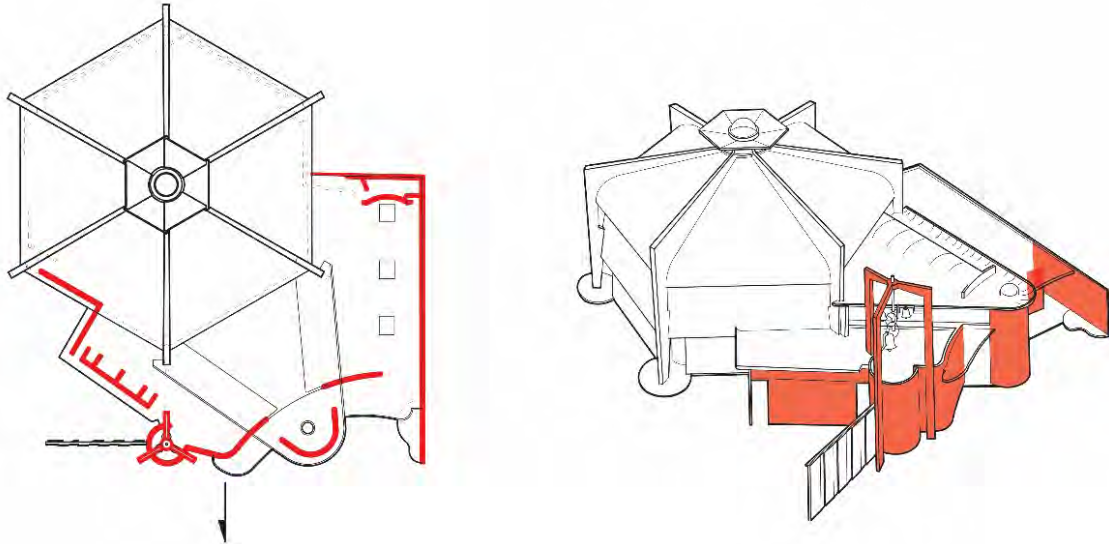


Fig. 4.12 - Reinforced concrete block masonry walls at the Del Carmen Church. Graphics by Author, 2020.

- **Poured-in-place concrete** was used in the structural columns for the dome, roof slabs, and the tilted walls under the dome. Portland cement stucco was used as a finish in these walls
- Poured-in-place concrete was only used for the curved eaves throughout the north side and narthex windows. These architectural surfaces were not stuccoed.

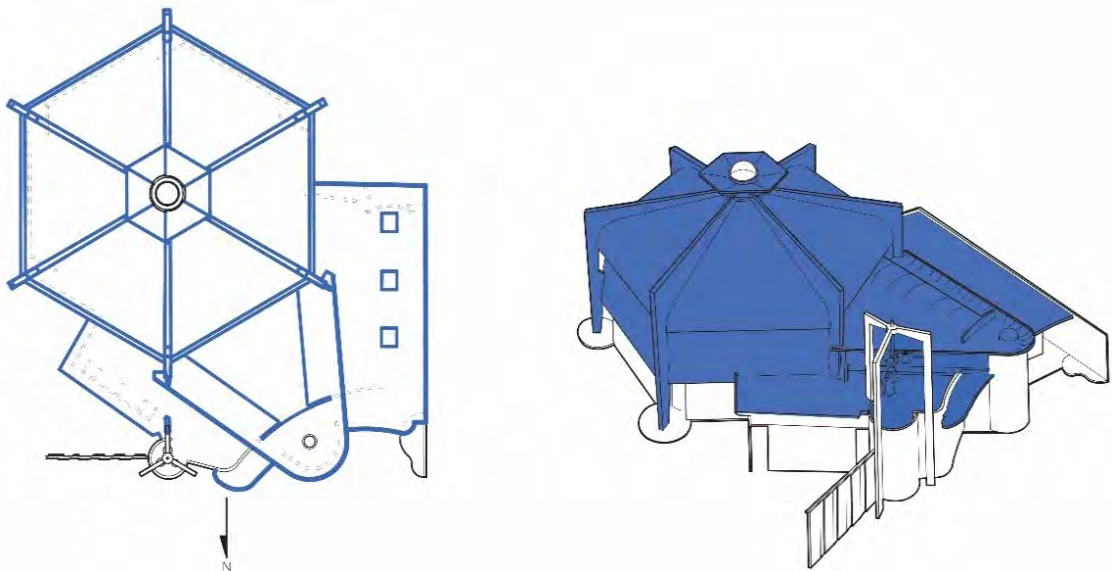


Fig. 4.13 – Poured-in-place walls at the Del Carmen Church. Graphics by Author, 2020.

**Precast concrete system** (Louvered grille exterior fence - made of vertical precast louver units. Precast at the site, each panel is approximately 6' high by 3" wide). These were used as decorative walls-panels on the Church's northside (Elevation 6, See Appendix). The application of any stucco to these panels is currently unknown.

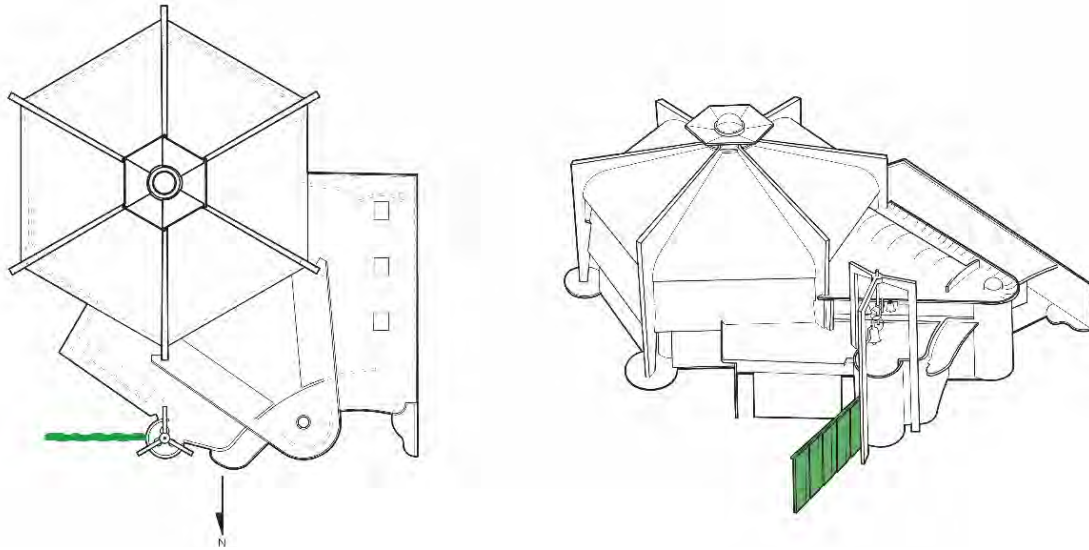


Fig. 4.14 – Precast panels at the Del Carmen Church. Graphics by Author, 2020.

It is known that unreinforced concrete works well in compression but is weak in tension. To mitigate this issue, reinforcement, usually steel, is introduced, which also helps prevent early shrinkage and subsequent thermal expansion and contraction. Since concrete and steel have similar coefficients of expansion and contraction, they work well together as a strong composite material.<sup>9</sup> In the Del Carmen Church, steel reinforcement throughout the building was placed depending on the concrete element that required it, so horizontal reinforcement is present on the concrete masonry walls. In contrast, cast-in-place elements feature diagonal and vertical reinforcement. Even though this is not confirmed, there is a reasonable probability that the Portland cement used and other materials for the church's construction were locally sourced.<sup>10</sup> The construction

specifications for the Del Carmen Church dated February 1961 mention the following regarding the original materials considered for the concrete walls of the building:

- Portland Cement - “A well-known, approved brand... Serial Designation [ASTM] C-150-55, Type I.”<sup>11</sup>
- Aggregate – “Both coarse and fine aggregate shall conform to ASTM C-33-55 T”; Coarse aggregate, “Hard, durable, uncoated crushed stone or washed gravel,” and Fine aggregate, “Natural sand, clean, hard, durable, uncoated grains, free from salt, loam, and clay... and shall not contain more than 3% silica.”
- Water – “Clean and free from oil, acid and injurious amounts of vegetable matter, alkalis, salt, and other deleterious substances.”
- Cement Retarding compound – “A liquid compound that will retard the setting of the cement surface. The compound shall not affect the setting of cement below a depth of 1/8 inches...It shall not contain any ingredients which injure plaster when applied to the roughened concrete. To use of a retarding compound is optional.”
- Curing Materials – “...Kraft paper, burlap, sand or pure polyethylene plastic sheet not less than four mils thickness, or Truecure manufactured by Truscon.”
- Forms – Wood forms: “...plywood Commercial Standard Douglas Fir, moisture resistant, concrete form plywood”, and Form linings: “Plywood or fiberboard lining sprayed with lacquer coating ‘Formlac’ as manufactured by Maxwell and Hitchcock.”

#### **4.5 Discussion of the exterior stuccoed finishes**

The majority of these specifications changed after the April 1961 Notice for Bidders No. 1 since Klumb opted to apply ‘spray-applied finishes’ on the exteriors of the Church. Since there are no records of the construction, the forensic investigation and additional archival documentation from other projects aided in the characterization of the building materials and technologies ultimately used.

The investigation found that the original outlined requirements in February 1961 were simplified. One of the significant changes in the April 1961 document is that a surface preparation for bonding the stucco was no longer mentioned. The document does explicitly

require that the concrete surfaces “shall be smooth, free of oil, blemishes, fines, honeycombs, etc.” It also requires a machine mixing for the mix and the application of a “spray apply specified finish to a thickness of from 1/6” to 1/8.”<sup>12</sup> Lastly, an April 1961 document required the protection of “adjacent work from spattering or soiling by means of dropcloths and taped paper.”

Polarized light microscopy (See Chapter 5) confirmed that a pneumatically applied or shotcrete system was used to apply the Portland cement stucco on specific architectural elements such as the tilted walls and belfry/bell tower. A traditional hand-applied stucco finish troweled to obtain a smooth finish was applied over all the north elevation walls, and a specific stucco formulation with a ferrous metallic aggregate was applied to the dome. While conducting on-site investigations, initial findings indicated that all Portland cement stucco had been applied to concrete (specifically poured-in-place and masonry segments), directly to the substrate, and no mechanical surface preparation for proper bonding was observed. There are various possible explanations: Klumb used a retarding compound on the different stucco mixes as specified, he used “Liquid Bonding Agents” as specified in other projects, or no bonding treatment was applied to the substrates at all.

There are some incongruences between the construction specifications, drawings, and what was built, which is usually the case in any construction project. As an example, the finish coat applied to the poured-in-place dome contains a ferrous metallic aggregate. Although this has been known by the priests and the church’s congregation for decades, this is not mentioned in any existing documents of the church, as examined in both AACUPR and the Penn Architectural Archives.<sup>13</sup> In other words, a specification for a “Waterproof Cement Plaster Finish” with a metallic aggregate was not described nor mentioned at the Del Carmen Church February 1961 original construction specifications. The forensic investigation suggests that Klumb and the contractor eventually followed the firm’s general “Waterproof Cement Plaster Finish” specifications as used for other

projects. Additionally, this research confirmed the type of ferrous aggregate/fillings since it is an uncommon feature on architectural concrete in Puerto Rico (See Chapter 5).

The construction specifications mentioned coating instructions for the precast louvered grille/panels as the application of “one coat of an approved mixture of water, cement, and ‘Thorobond’ to all surfaces.” Still, it is unknown if this application occurred since the thickness is absent from the final drawings, and no additional information has been found, nor has there been any confirmation of this finish in the instrumental analyses from the samples taken. Lastly, the forensic investigations also found that the stucco composition is different from that outlined in the February and April 1961 documents (See Chapter 5 for a further discussion).

Over the last two decades, the original exposed Portland cement stucco and remaining concrete surfaces have been covered by several painting campaigns. At least two different paint colors have been identified in the north and principal elevation of the church. The roof slabs, dome, and structural columns on the roof have been painted using a modern sealing roof paint & waterproof coating. Several layers of ‘gray coating’ along with a waterproof white coating were found on the roof and dome in the on-site assessment and aerial photographs.



*Fig. 4.15 & 4.16 – Sealing roof paint & waterproof coating conditions at the Del Carmen Church. Photos by Author, 2020.*

From the on-site observations, some structural columns on the south side of the church, specifically the base of Columns D and E (See Appendixes 2), show how these could have possibly had significant repairs in the past. In these columns, the Portland cement stucco texture seemed different than that of the other structural columns, resembling a heavier sandy finish used in exteriors of contemporary concrete buildings in Puerto Rico. Other minor repairs involved the filling of cracks on the cast-in-place curved eaves of the Narthex (See Elevation 10 on Appendix 2) and major spalling with incompatible concrete repairs in the back of Column F, under the Dome (See Appendix 2).

#### **4.6 Climate in Cataño, Puerto Rico**

Puerto Rico is in the Subtropical Caribbean region. As established by the National Center for Environmental Information of the NOAA, the islands possess warm and humid tropical conditions with minimal temperature variations between seasons. Because of its



topography, the northern part of the islands has a humid climate, and the southern portion has a drier, semiarid climate. The annual average temperature in Puerto Rico is 81°F, and in Cataño is 86.7°F. Temperatures usually are cooler in January (with an average maximum temperature of 83.2°F) and become warmer in August (with an average maximum temperature of 89.2°F).<sup>14</sup> The islands usually experience wetter summers and dry winters. The annual average mean precipitation in San Juan-Cataño is up to 67.76 inches, May through October being the most humid season because of storms and hurricanes and easterly waves (Appendix 4). The annual relative humidity is 65% and up to 68% in the wettest months. Since the 1950s, heavy precipitation has increased substantially in the area.

The 'North Atlantic subtropical high' phenomenon causes prevailing trade winds predominantly from the east and northeast. Henry Klumb always considered the natural surroundings of his project's in all his designs. He positioned his buildings taking advantage of natural light as well as natural ventilation. In the Del Carmen Church, the diagonal plan faces the winds coming from the east side. The northeast trade winds bring water vapor for precipitation along the northern coast of the main Island and outlying islands. Wind speed in the San Juan-Cataño area is 8.3 mph annually and up to 9.6 mph in August.

Lastly, since Puerto Rico is in a hot tropical region, one crucial aspect to consider is the area's Solar Radiance. Data from the National Renewable Energy Laboratory of the U.S. Department of Energy shows April through August as the months with the highest Solar Radiance data in the region, with July having up to 1930 Btu/ft<sup>2</sup>-day. The annual solar radiation for the area is 1680 Btu/ft<sup>2</sup>-day.<sup>15</sup> In a tropical region, solar radiance can have a significant impact on the relative humidity of the environment. The urban heat island effect causes temperatures to rise faster in the San Juan metropolitan area,

including Cataño, than across the rest of the islands. Surface temperatures of the surrounding ocean area are an essential 'regulator' on temperatures in the islands and have risen by approximately 3° F since 1910.

#### **4.7 Deterioration of Concrete and Cement stucco**

The weathering of building materials by sun, wind, and rain is the alteration of their physical and chemical properties.<sup>16</sup> Some of these processes are patent (visible) or latent (non-visible) and can take years to develop on the building fabric.<sup>17</sup> When considering cementitious materials such as Portland cement and concrete, exposed to the weather, these are prone to a series of conditions that could compromise the integrity of the material and the building. Both concrete and cementitious materials such as Portland cement stucco are continuously changing in their physical conditions, from mixing to the placement and gaining strength after curing and being exposed to exterior environmental conditions.<sup>18</sup> In the Del Carmen Church, we must keep in mind that exposed stucco surfaces are usually the first to deteriorate with an extreme variation of climate conditions. For example, a deep erosion of the exposed stucco can lead to water penetration and accelerate the decay of both the stucco and substrate. Another example is how a stucco poorly bonded with the substrate can collapse in large sheets. In summary, in the deterioration of building materials, all physical, chemical, and organic weathering processes can act individually, together, or successively.

As the process of weathering enacts physical and chemical changes due to climate conditions, physical changes often manifest as thermal, moisture, atmospheric, and light and electromagnetic radiation. These changes do not result in any chemical change; instead, they alter material performance and physical character, paving the way to develop chemical and organic weathering issues.<sup>19</sup> Thermal movement occurs when the materials

are exposed to various thermal changes, leading to expansion and contraction. Cementitious materials, especially in exterior environments, are prone to cycles of low and high temperatures, expanding and contracting and ultimately weakening the bonding between materials. This can result in problems such as cracking, delamination, etc. For example, a Portland cement stucco applied to a cast-in-place reinforced concrete wall will have different temperature fluctuations than the substrate, even if they have similar coefficient expansion rates. This phenomenon is due to exposure of the stucco to the sun and heat vs. the poured-in-place wall and its thin cross-section. Portland cement stucco shrinks about 0.14% or 0.168 inches per 10 feet and expands at a rate of 5.9 to 7.0 times  $10^6$  inches/inch degrees Fahrenheit (about 0.07 to 0.084 inches per 10 feet in length per 100 °F). These expansions and shrinking changes in Portland cement stucco can eventually cause stress on the bond between the two materials, resulting in debonding failure.<sup>20</sup>

Moisture movements on materials are the result of the absorption of water into porous materials, such as concrete. Water absorption leads to an increase in the volume of the material, while moisture loss decreases its volume and shrinkage.<sup>21</sup> Hydraulic materials such as stucco, plasters, mortars; require the addition of water during their manufacture shrink as they set and are resistant to wetting processes. Excessive moisture, often caused by rising damp, condensation, leakage, and poor water management issues, are often the most common conditions affecting these building materials. High levels of moisture, which often become trapped within the internal porous structure of materials, can set up the necessary environment to develop detrimental biological and chemical conditions. Moisture not only increases or decreases the volume of materials, but it can also transport chemical contaminants such as soluble salts through the material's porosity.<sup>22</sup> Cement stucco is almost impermeable, meaning that it can trap

vast amounts of moisture in between the stucco skin and the substrate, pushing moisture up the wall, leading eventually to serious deterioration issues.<sup>23</sup> In a tropical environment, high moisture levels, combined with other environmental and materials composition factors, are detrimental and corrosive to metals. Metals form expansive iron oxides and other compounds by electrolytic action, affecting metals such as steel rebars destroying and detaching reinforced concrete technologies.<sup>24</sup> Due to wind directions coming from the northeast and east side of Puerto Rico, it is known that buildings that face these directions are prone to reinforcement corrosion.<sup>25</sup>

Atmospheric gases and pollutants on the environment also have an enormous influence on the weathering and performance of building materials since the atmosphere contains water vapor, pollutants, and particulate material.<sup>26</sup> Two main common compounds that can be detrimental are sulfur dioxide (SO<sub>2</sub>) and carbon dioxide (CO<sub>2</sub>). Sulfur dioxide forms sulphuric acid with HO<sub>2</sub> molecules (like rainwater), affecting materials with calcium carbonate (including limestones, mortars, marble, stucco, and cementitious materials). Carbon dioxide, when dissolved in HO<sub>2</sub> (rainwater), forms carbonic acid, which can affect cementitious materials. Considering that Del Carmen Church's site is on the bay, sodium chloride (sea salt) and other chlorides usually present in the maritime climate can damage porous materials (stucco and concrete) through crystallization within their pore structure.

In tropical environments, light and electromagnetic radiation also impact the performance of building materials, especially organic materials such as coatings and plastics. For example, ultraviolet radiation can break chemical bonds, leading to oxidation, discoloration, and embrittlement.<sup>27</sup>

In a tropical marine environment, marine spray/marine aerosol can induce substantial reinforcing steel corrosion, salt crystallization depositions, and other

pathologies in concrete and Portland cement stucco. Marine spray is formed by inorganic salts (sulfates, nitrates, and chlorides) and organic matter, along with mineral and metallic airborne particulate from the surrounding environment, and usually transported with both wind and rain.<sup>28</sup> Soluble salt depositions and crystal solubilization can attract moisture, increase crystal growth, and thus increase internal stresses within a porous material.<sup>29</sup>

Besides the environmental physical, chemical, and organic factors, human activities, and their behavior toward the built environment play an essential role in the performance of a building. From design and construction to occupation and use to repair and maintenance practices, all affect the building's longevity as a system. Poor design and materials specifications, along with poor construction workmanship, can lead to the quick decay of a building, which, combined with the factors previously discussed, can have detrimental consequences not only to its aesthetic appearance but also to the health and safety of its users.<sup>30</sup> For example, mid-century modern buildings often incorporated inadequate conventional detailing such as overhangs, drips and sill edges and copings, design issues that have led to a significant number of detrimental problems over time.<sup>31</sup> Also, researchers point out how the design and aesthetic decisions on modern buildings contributed to air and water infiltration issues because of the lack of advanced vapor barrier and sealant technologies in the era, along with the use of fragile materials that led to serious weathering issues.<sup>32</sup> In Puerto Rico, because of the hot weather, contractors historically had ignored standardized practices for curing concrete, which sometimes has affected the material's performance.<sup>33</sup>

In the Del Carmen Church, because of the lack of documents and records during its construction phase (the available records are from the design and planning phases only), it has been challenging to figure out construction procedures between 1961 and 1962. The lack of documentation of construction and workmanship changes, such as

adding the ferrous metallic aggregate to the dome's stucco and leaving the exterior surfaces unpainted, provides a clue to how and why some decisions were taken during that phase.

While considering ACI and ASTM specifications from the era, between 1957 and 1963, ACI was just developing its first standards for concreting in hot weather, published in 1959 as ACI 605-59- *Recommended Practice for Hot Weather Concreting*. The standards only considered 'high temperature and low humidity or wind' climates, excluding tropical regions such as Puerto Rico. As mentioned before, because Concrete was believed to be a maintenance-free material, the construction industry and concrete scientists started developing research on concrete and Portland cement in hot climates in the late 1950s. For most of the twentieth century, all applicable standards from northern climates were used in the islands for concrete constructions, with local practices/knowledge from Puerto Rican masons, construction workers, and professionals.<sup>34</sup> Hence, concrete and stucco workmanship practices in the construction phase of the Del Carmen Church (1961-1962) probably followed mostly local knowledge along with general concrete standards. Still, with the lack of documentation, workmanship issues on the stucco and concrete surfaces in the Del Carmen Church are almost impossible to assess and required a specialized investigation such as material characterization that involved concrete petrography.

Despite this issue, the analysis of historical photos of the Del Carmen Church and the consideration of regional climate factors can provide an idea of the workmanship on the building's concrete surfaces. Different documents and studies from the industry point out that hot weather creates specific conditions in mixing, placing, and curing concrete affecting its performance and service.<sup>35</sup> The formation of moisture staining and surface variations such as color fluctuation can occur due to varying hydration rates, internal

temperatures, or water-cement ratio. In addition, bio-growth staining or fouling can happen quickly on surfaces completed early in the construction process.



*Fig. 4.17* – Del Carmen Church during construction in 1962. The variations on the stuccoed surfaces can be seen since the construction phase. Source: Henry Klumb Collection, AACUPR.



*Fig. 4.18* – Del Carmen Church before inauguration in 1963. The differences in the concrete masonry surfaces are evident vs. the dome finish. Source: Henry Klumb Collection, AACUPR.



*Fig. 4.19* – Del Carmen Church before inauguration in 1963. The differences in stuccoed surfaces can be seen also in the bell tower. Source: Henry Klumb Collection, AACUPR.

As an example, these historical photos show how probably poor workmanship and quality control affected the exterior stucco surfaces. The application of stucco patches over the block masonry wall without control of the mix ingredients can produce curing differences between the already drying stucco and the newly applied stucco. Hot and humid tropical weather could affect the application and drying processes of these stucco patches, leading to a difference in appearance compared with the already dry stucco layer. In this process, bio-fouling, which usually attacks the wet stucco, becomes more visible because of the uneven surfaces.

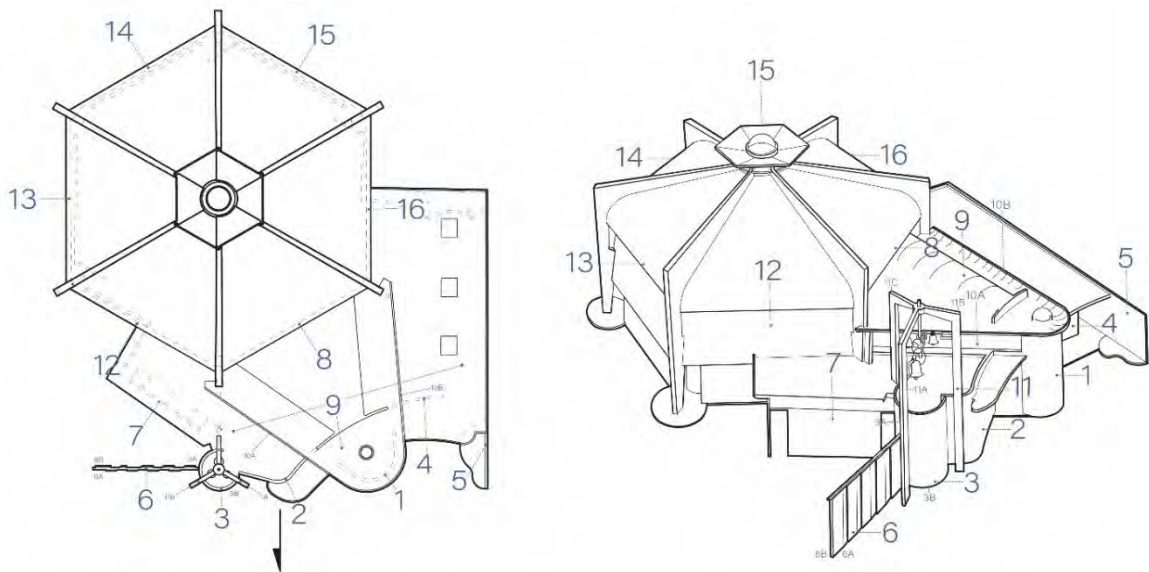
On the other hand, it is known that the relative humidity in Puerto Rico (which is not lower than 70%) naturally retards the premature drying of concrete. This environmental factor is also beneficial for the material's strength. Studies show that concrete gets stronger with time, developing over 20% higher strength in humid environments in contrast to dry climates.<sup>36</sup> This factor probably helped the exterior concrete to survive decades of weathering in an extreme environment with infrequent or no care at all.



Lastly, maintenance practices in the church have changed over the decades. Lack of financial resources, expertise, and changes in needs have been detrimental to the building. There are no exterior current maintenance practices, and often there are inappropriate exterior cleaning routines and repairs, especially in the roofs and dome areas.<sup>37</sup>

#### 4.8 Current conditions of the exterior surfaces of the Del Carmen Church: General findings

During the on-site investigation, over 69 elements of the exterior surfaces were assessed for a total of 27 elevations (18 wall elevations, 3 elevations of the Belfry, 6 elevations for the structural columns).<sup>38</sup> The conditions on the elevations on the north side of the church were analyzed first, followed by the east, south, and west sides. The detailed drawings can be consulted in the Appendix section.



*Fig. 4.20 – Distribution of Elevations for the condition assessment for a total of 18 (including 3A, 3B, 6A, 6B, 10A & 10B); plus 11A, 11B & 11C, which are assigned for the belfry, and the six structural columns. Graphics by Author, 2020.*

The Del Carmen Church features six structural columns that support the dome throughout. As part of the maintenance campaigns of the church, the grey roof coating previously applied to the roof slabs has also been applied to the dome and several sections of the structural columns. Structural walls inside the church support columns A and B.

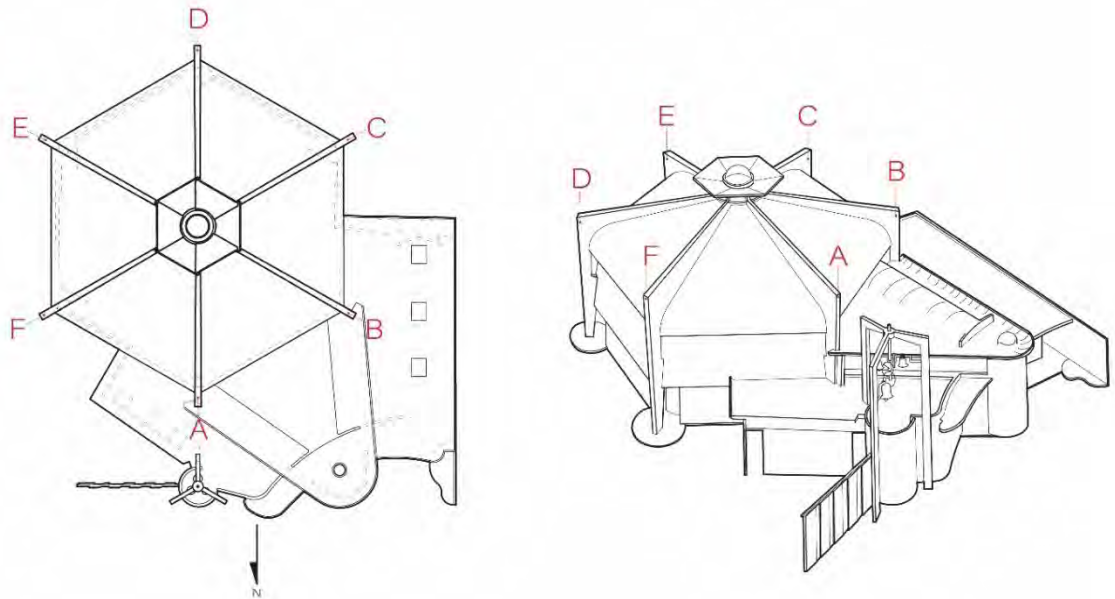


Fig. 4.21 – Structural columns at the Del Carmen Church identified for the conditions assessment. Graphics by Author, 2020

The condition assessment of the exterior surfaces of the Del Carmen Church identified a total of ten (10) conditions. Five (5) principal conditions were considered significant: cracks, incipient detachment/debonding of stucco, loss of stucco/scaling, surface fouling (bio-staining), and macroflora. These ten (10) conditions were selected after carefully evaluating the final Conditions Drawings and notes. In the process, three (3) primary conditions of each elevation were compiled in a list. Then, the number of times the conditions occurred on each elevation was scored to create the final list of the ten principal conditions affecting the church (See Appendix 3 for the complete list).

The first and most common condition on the church's exterior surface is *Cracks and crazing*. 19 elevations out of 27 showed that cracks are among the top three (3) main conditions. ACI standards define cracks as "a complete or incomplete separation, of either concrete...masonry [or stucco], into two or more parts produced by breaking or fracturing." Cracking in concrete and stucco must be reported based on their width and type.<sup>39</sup> For this assessment, three main types of cracks were identified on the concrete and stuccoed surfaces of the Del Carmen Church: hairline cracks, slight cracks, and large cracks (see Conditions Glossary).<sup>40</sup> Despite this classification of cracks based on their width, there are two main classifications of cracking patterns based on their direction on the surfaces: multi-directional lines and directional lines. Multi-directional line cracks in exterior surfaces, especially in stucco (often known as craze cracks), can result from the shrinkage or drying processes, weak bonding, and lack of scouring on the substrate.<sup>41</sup> Directional lines can emerge from differential movements within the materials or blocked openings, structural movements, sulfate attack, shrinkage stresses (typically diagonal), and rust staining from the corrosion of embedded steel rebar on the concrete substrate. High percentages of relative humidity in hot wet environments can penetrate the material quickly aided by cracks, which along with elevated temperatures it can accelerate the corrosion of reinforcement. Cracking surrounded by light-colored zones can be a signal of rapid drying shrinkage.<sup>42</sup> Weathering patterns that cause thermal movements and/or moisture movements, as well as the formation of soluble salts (such as sulfate attack), are often responsible for expansion, leading to the breakdown or a failure of the concrete and stucco, leading to cracking patterns in exterior surfaces.<sup>43</sup>

The second most common condition is *Detachment/Debonding*, which was found on 16 of the 27 elevations. As defined by ACI CT-18, detachment or debonding is a bond failure at the interface between a substrate and a material. It is usually identified in

stuccoed surfaces as 'drummy areas' or an "area where there is a hollow sound beneath a layer of concrete [or stucco] due to delamination, poor consolidation, or void."<sup>44</sup> If cracks are present in an area of the surface identified as 'detached,' these cracks can allow the ingress of water and humidity to increase, enabling other deterioration mechanisms between the substrate and the stucco and accelerating its eventual separation. The more extensive this condition is detected on a surface, the higher risk of collapse of material from the wall.<sup>45</sup> Also, detachment in small areas with no cracking can occur due to drying shrinkage, poor adhesion of the stucco to the substrate, and high strength of the stucco mix vs. the substrate resulting in differential thermal movements. Detachment can also occur due to salt crystallization between stucco and substrate and the application of an impermeable coating in the stucco, interfering in its breathability. As seen, thermal movements, moisture movements, and atmospheric gases and pollutants can help develop this detrimental condition on the exterior surfaces.

The third most common conditions found on the exterior surfaces are *Loss of stucco/Scaling* found in 15 out of 27 elevations as one of the top three issues. As defined by the American Concrete Institute, scaling is the "local flaking or peeling away of the near-surface portion of hardened concrete or mortar (stucco)."<sup>46</sup> This condition develops over concrete and stuccoed surfaces due to abrasion caused by the growth of plants or abrasive cleaning methods, crystallization of soluble salts in the surfaces, loss of a laitance crust because of poor workmanship or overworking on the surface, resulting in spalling of the masonry behind the stucco or surfaces. Lastly, loss of surface can also develop if there is a stronger and impermeable material applied to a weaker substrate.<sup>47</sup>

The fourth most common condition is *Surface fouling*. 11 elevations of 27 showed that Surface fouling was one of the top three conditions. Surface fouling may be due to black carbonaceous surface deposits from atmospheric pollution or black biological

growth, usually fungal. In Puerto Rico, as a tropical archipelago with hot temperatures and high relative humidity, biological surface fouling is most common and indicates wetness areas. Surface fouling has been a constant issue in the past for the exposed surfaces of the Del Carmen Church, as seen in historic pictures since 1964.



*Fig. 4.22* – Del Carmen Church c.1965. Extensive surface fouling issues in the form of black bio-growth has been present in the dome since its early days. Source: Henry Klumb Collection, AACUPR.



*Fig. 4.23 & 4.24 – Del Carmen Church c.1999. Atmospheric soiling and bio-growth on the exposed surfaces before the painting campaigns of the 2000s. It is possible that a coat of paint was applied in the late 1990s to address surface disfigurement. Source: R. Otero*



Fig. 4.25 – Del Carmen Church in 2006. All the concrete and stuccoed exterior surfaces after the second paint campaign. The first paint campaign was applied between the late 1990s and early 2000s. Source: Madeline Ocasio, Flickr.

*Macroflora* is another of the principal conditions found on the exterior surfaces of the building. Four (4) of 27 elevations showed that biological growth was one of the top three issues. *Macroflora* is related to the presence of higher plant forms. Plants and trees can affect buildings through the subsoil (effect of roots on foundations or underground drains) and the walls and roof coverings (like a blockage in gutters, shaded parts of buildings, and prevent moisture evaporation on wall surfaces). All organic growth, from *macroflora* to black-biological grow, can be detrimental for exterior masonry surfaces since they can attract and retain vast amounts of moisture. Their acidic metabolic products can be damaging, and they can even change the porosity and permeability of the surfaces. These factors can act jointly, separately, or successively on the masonry materials causing microcracking and surface erosion.

*The peeling of paint* is also one of the most common conditions at the church. Four (4) out of 27 elevations showed that the peeling of painting was one of their top three

issues. Peeling refers to a process in which the applied surface coatings or paint layers detach and 'peel' from the surface, revealing underlying layers of the substrate.<sup>48</sup> This condition can be seen mostly in the surfaces exposed to weather conditions, sun and ultraviolet radiation, and precipitation- as well as surfaces increasingly exposed to moisture issues such as rising damp. The painting layers create a barrier for the breathability of the stucco and the other concrete surfaces, preventing proper evaporation. Both the humidity and exposure to other elements erode the paint films.

Another common condition is *Discoloration*, which is seen on the paint applied to the stucco and concrete surfaces. Three (3) out of 27 elevations showed discoloration as one of their top three issues. The ACI acknowledges that the discoloration of surfaces is a 'departure of color from that which is normal or desired.'<sup>49</sup> This phenomenon often occurs on exterior surfaces by water passage, penetration or irregular channeling, and the constant effect of ultraviolet rays.<sup>50</sup> Moisture movement on the surfaces, light, and other electromagnetic radiation and atmospheric gases and pollutants are often responsible for the development of discoloration on exposed surfaces.

Lastly, *Rising Damp Damage* is found on three (3) out of 27 elevations as one of the top three conditions, specifically evident on the elevations on the north side. Rising damp occurs on masonry walls when water penetrates the wall from ground levels and around openings. Water will rise in the wall because of capillarity action (or surface tension), causing moisture to move through the porous building material and natural osmosis in which the moisture moves from solutions of lower to high salt concentrations. This phenomenon can be extremely detrimental to the exposed concrete and stuccoed surfaces since it can increase dampness or excessive moisture, leading to salt formations, fungal attack, disruption of internal wall surfaces, and staining. Pore size and distribution of the exposed surfaces along site water management play a vital role in developing this



specific condition. As the site on Del Carmen Church has been identified since 1960 as ‘sandy-lagoonal’ soil, its retention of moisture and how it affects the building’s foundations and exteriors must be carefully assessed through a specialized study. Moisture movement and excessive moisture on the surfaces are often responsible for the development of rising damp damage on exterior masonry surfaces.

Lastly, the presence of pigeons (*Columba livia*) and the remains of guano on the church’s exterior surface is an issue that the church administration has been dealing with for years. Still, these birds can inflict indirect damage to the building with their nesting practices, blocking rainwater disposal systems and soiling wall surfaces with guano. Lastly, water management and drainage from the roof, which will be discussed further, is a significant issue affecting the parochial church’s roof and exterior/interior concrete surfaces.



*Figs. 4.26 & 4.27* – In the early 2010s the Church’s administration installed a pigeon netting along the dome. These nets are currently deteriorated. Photos by Javier Freytes, 2019 & Author, 2020.

#### 4.9 Findings - Specific conditions

Significant conditions found at the Del Carmen Church can be summarized as the following:

1. *Cracks and crazing* – These are the most prevalent condition on Elevations 5, 6A, 6B, 8A, 11C, 12, 16, and in Column A. Elevations 6A & 6B (precast concrete panels) horizontal, diagonal, and vertical slight, and hairline cracks indicate possible corrosion of the reinforcement since metallic corrosion is visible on the small metallic grates which are attached to the concrete surfaces. On Elevation 5, both vertical and horizontal hairline/slight cracks are signs of reinforcement corrosion on the concrete block masonry system. Dampness and soluble salt ingress from the environment can also affect the stucco expanding and forming crack patterns. Also, nails from previous signs have been used in the stuccoed wall, which is now exposed and corroding. The cast-in-place stuccoed tilted walls of Elevation 8A, 12 & 16 exhibit large areas of diagonal/vertical hairline cracks. Along the elevations on the façade, these areas on the building are the most exposed to the Bay. Differential movements by exposure to the sun, the wind, and rain (marine splash with soluble salts), along with an impermeable coating (paint), are possible sources for these cracks on the stuccoed surfaces. On the belfry, Elevation 11C shows large and slight cracks running vertically and crazing, passing through damp stained debonded stucco, a sign of possible alkali-silica reaction (ASR).<sup>51</sup> Corrosion is present on the pipes embedded into the thin concrete structure, which supports the bells; no cracks were seen, height limitations prevented a close inspection of that area. Minor cracks could be found on the lower part of Elevations 11A & 11B, possibly due to the movement of the slender concrete block supports of the belfry by strong winds. Lastly, Column A

shows a considerable amount of short hairline cracks and discoloration patterns along all elevation sections. These short hairline cracks can be attributed to exposure to the elements, soluble salt ingress, and drying patterns/movements. Lighter stains around the cracks show moisture ingress and possible leaching of the mix components such as the hydrated lime.

2. Detachment/Debonding – These are found as the top condition on Elevations 2, 4, 8A, 11B, 13, 14, 15, and in Columns C, D, & F. Some of the issues that lead to debonding are the constant wet conditions on Elevations 2 & 4 because of rising damp issues and poor drainage. On elevations 8A, 13, 14 & 15 (sprayed/shotcrete applied stucco), thermal movements, cracks, and the paint coating, which prevents breathability, are possible causes of detachment. This condition is exacerbated since the poured-in-place substrate was not mechanically prepared for the application of sprayed/shotcrete stucco, which implies the potential use of liquid bonding agents. However, further study is needed to confirm this possibility. Lastly, on Columns C, D, F, cracks leading to moisture and salt ingress and damp soil along the paint coating are possible factors for the detachment of the stucco. In Column C, on the lower part of section 1, an Aggregate-aggregate reaction (AAR) is found on the stucco (with a crazing pattern). This is possible since improper interventions that used a different mix repair in Columns C, D & F were seen. On these columns, the stucco texture was flatter and sandier (resembling modern stucco) than the other columns on the building. This also indicates previous detachment issues that were addressed years or decades ago.
3. Loss of stucco/Scaling - These are found under the top three (3) condition on Elevations 1, 3B, 4, 5, 7, 11A, 11B, 11C, 13, 14, 15 and Columns D, E & F. Some of the possible reasons for the loss of stucco on elevations 1, 4, 5, and 7 are improper and constant abrasive cleaning, signage attached to the walls, humidity

by rising damp and/or water flows because of poor drainage. On elevation 3B, poor drainage, soil retention of rainwater, crystallization of soluble salts, and absence of direct sunlight in the area have led to a considerable amount of moisture near the area. Crystallization of soluble salts and bio-fouling, which could have attracted moisture over the stucco, are also possible sources of scaling on the belfry (Elevations 11A, 11B, 11C). On the other hand, a considerable amount of scaling has been recorded on Elevations 13, 14, 15. Possible sources are improper abrasive cleaning of the stucco, overworking the surface while applying the sprayed/shotcrete stucco, and bio-fouling attack. Lastly, macroflora growth, along with rainwater flows and salt crystallization, are possible sources of significant loss of stucco on the joints between dome and columns in Columns D, E, and F. Over the years, painting has been applied over failed stucco in all elevations to cover the scalling issues.

4. Surface fouling - These are found as one of the top three (3) most common conditions on Elevations 3A, 3B, 4, 6B, 7, 8B, 12, Columns A, B, C & F. Elevations 3A, 3B & 6B have high moisture concentration, both from the rising damp and water flows because of poor drainage issues in the building leading to ponds in their surroundings. Black biological fouling has grown along macroflora. These walls are also prone to sea spray exposure. Because of height, Elevations 8B, 12, and the overall dome are the most exposed architectural elements of the building. Water flows, sun and sea spray have an enormous impact on the area, leading to bio-fouling growth and atmospheric staining over time. Also, Columns A, B, C & F are some of the most exposed architectural elements to the bay and sea spray. The humidity and sun have an impact on the formation of biofouling in these columns. As discussed, surface fouling has been an incurring problem on the church's exteriors since the 1960s.

5. Macroflora - These are found as one of the top three (3) most common conditions on Elevations 3A, 5, 6A, 6B & Column E. Elevation 3A exhibits high moisture levels from poor drainage. This area also has a garden. Poor drainage, soil retention of rainwater, and absence of direct sunlight in the area have led to a considerable amount of moisture in the wall's base. Insects and other organisms were found with scaled parts of the stucco inside. Elevations 5, 6A & 6B show a similar issue since macroflora grow very close to the walls, leading to significant soil retention of rainwater and high moisture levels, which allows the development of leafy plants. On the other hand, Column E's area was exposed to a range of vegetation until the trees were cut two (2) years ago after Hurricane María. During the assessment, spores/seeds of a plant were seen attached to the painted stucco, and thus sometimes becoming a full leafy plant attached to the column. The same happened in Elevation 13, where small leafy plants were seen growing on the lower part of the tilted wall and on which water flows regularly runs without direct sun.

For specific photos of the conditions by elevations, see Appendix 3.

Additionally, Elevation 9 comprises a basic condition assessment of the roof slabs without the dome. The assessment looked at how water behaves over the roof since there are currently roof leaking issues in the baptistry area and others reported during the past decades. After the on-site evaluation, it was discovered that there are major temporary and permanent ponding areas on the roof. The church's drawings showed how Klumb designed three drainages for the flat roofs. The church administration added additional drainage near the baptistry, which probably causes the high moisture issues to Elevation 3. Currently, the original drainages designed by Klumb are not working or clogged-up, leaving the water management of the roof dependent on just one drainage (near the

baptistry) aided by sunlight/wind evaporation. Ponding or stagnant water is a serious issue affecting the roof since it has resulted in an increasing amount of mold and organic matter, destroying the previous roof sealing treatments. The building located on the west side (built between the 1930s and 1940s) has a broken drain. The conditions of the church's roof are exacerbated with an uncontrolled flow of large amounts of rainwater from the building next door, which is two stories taller and aggravates the deleterious situation further.

#### **4.10 Potential risks exacerbated by climate change**

Variations in climate considerably influence the performance and longevity of the building materials.<sup>52</sup> The Fourth National Climate Assessment published in 2018, which is one of the most recent Climate Change summary reports of the U.S. Caribbean region, along with other studies, predicts that there will be the following changes affecting the whole region in the next 50 years:<sup>53</sup>

- The Caribbean climate will change as levels of greenhouse gases in the atmosphere increase. As global carbon emission increases, the current average rainfall will be reduced by 2100.
- The temperature for the whole region is set to increase from 1.5°F to 4°F by 2050. The projections point out fewer cool nights (more nights over 85°F) and more hot days (over 95°F).
- Change in average temperatures in the region will lead to extreme temperatures and significant changes in hydrological cycles (lack of freshwater, increase in intensity and frequency of droughts), and the decline of 10% of annual precipitation. Urban heat phenomenon that affects the San Juan metropolitan area, including Cataño, will increase exponentially.

- Even though tropical conditions in Puerto Rico will become dryer, climate change will allow for more extreme rainfall events (increase in intensity and shorter but wetter wet seasons), which will negatively affect the ecosystems and fragile infrastructure.
- Changes in ocean surface temperature (which has increased to a rate of 0.36°F + per the last two decades in the waters of the northeast Caribbean) will continue warming up to 0.43°F, which will lead to ocean acidification, sea-level rise, and changes in frequency and intensity of storms and hurricanes.
- Sea level rise projections indicate an increase of 0.8 ft, 1.2 ft, or 2.8 feet by 2050 and between 1.0 ft to 8.2 ft by 2100. This, combined with stronger wave action and higher storm surges, will increase coastal flooding and erosion, representing the loss of sands, beaches, and danger for coastal towns, which hosts 60% of the islands' population.<sup>54</sup>

The Fourth National Climate Assessment highlights some of the leading threats imposed by climate change, including its adverse effects on cultural heritage in the U.S. Caribbean region. Sea level rise, coastal erosion, and storm surge can negatively affect the structural stability and footings of Del Carmen Church since it stands across from the San Juan Bay. On the other hand, short, intense precipitation events and higher temperatures can exacerbate wetting and drying cycles in the exposed stucco and concrete surfaces producing cracks, moisture entrance, increased formation of salts, and biological growth, leading eventually to progressive deterioration patterns. The lack of a proper and efficient drainage system will continue to create stagnant water areas and increase infiltration possibilities. Also, inefficient and intermittent waterproofing protection of the roofs could prevent adequate roof drainage. The dry and arid projected climate will lead to increased exposure of the exterior surfaces to ultraviolet light, which can be

detrimental to most roof waterproofing systems, mostly not designed for tropical climates and weather exposure.

Higher temperatures can lead to modifications in the microstructure and microporosity of concrete and even exacerbate the reinforced steel's corrosion activity.<sup>55</sup> This could be controlled by the sealing treatment of surface cracks that might permit the steel's weathering. Still, dry conditions can also benefit the stability of the stucco and concrete surface because the lack of high amounts of moisture can prolong their durability.

#### **4.11 Recommendations for future assessments, further testing, and monitoring**

The following are a set of recommendations that should be considered for further study of the Del Carmen Church:

- Use of specific scaffolding or scissor lifts to access higher parts of the building that could not be surveyed.
- The use of a point station or laser scanning technologies to develop a more precise set of drawings. Since the drawings used in this study were developed using the original historic drawings and limited on-site measurements, more precise equipment is recommended.
- There is a need for a comprehensive condition assessment of the dome and cupola areas, which were not physically accessible due to their height and slopes. Signs of spalling and steel reinforcement corrosion were identified on the cupola from a distance.
- An in-depth study of the water management and drainage systems of the church's roof to prevent roof leakage and water infiltration. The development of a new-water-proof surface covering, similar to the original one, would solve these long-term problems. The adjacent building's drainage into the church's roof must be



diverted and not empty into the church's roof. Overall, once these conditions are stabilized, additional roof drainage methods could be considered.

- A study of the soils and the conditions of the footings of the church. A quick examination of the soils in the garden on the northeast side, between the confessionary and the precast panels, showed how the clayey and muddy soil retained a considerable amount of moisture. This could be solved through the design of appropriate systems at the ground level planted areas.
- Since there are significant issues with detachment/debonding of stuccoed surfaces and early signs of rebar corrosion, a comprehensive study on the rebar around the building and cathodic protection recommendations must be undertaken.
- The clay tile/terracotta block grilles on the southern side of the church are currently in a detrimental condition. The clay tiles were filled with Portland cement mortar and steel reinforcement and are presently exhibiting significant biological staining, corrosion, and delamination issues.
- Assessment of other exterior and interior elements such as wooden doors, original plastic domes, bells, and original wooden furniture designed by Klumb to determine its state of conservation.
- Monitoring of large cracks for movement on specific walls.
- Lastly, it is strongly recommended an assessment of the interiors surfaces of the church to complement the findings of this Survey.

## Endnotes

---

<sup>1</sup> David Odgers, ed., *Practical Building Conservation: Concrete*, (London, UK: English Heritage, 2012), 72.

<sup>2</sup> Some common admixtures and additives are natural pozzolans such as volcanic ash, other industrial products such as fly ash, blast furnace slag and silica fume.

<sup>3</sup> Pender, Ridout and Curteis provides an overview of different common types of assessments such as the Assessments to Interpret problems, the Assessments to prepare for alterations and a Detailed Survey. This last

---

type of assessment is comprised of visual inspection, conditions mapping and extraction of samples for analysis. Even though the proposed assessment is defined as a 'Building Fabric Survey,' questions from other assessment approaches were chosen to complement the present analysis. Robyn Pender, Brian Ridout, Tobit Curteis, ed., *Practical Building Conservation: Building Environment*, (London, UK: English Heritage, 2014), 214.

<sup>4</sup> Ed Fitzgerald, "Condition Assessment: Tips for Historic Building Owners," National Center for Preservation Technology and Training (NCPTT), National Park Service, U.S. Department of the Interior (August 31<sup>st</sup>, 2010), accessed on January 10<sup>th</sup>, 2020, <https://www.ncptt.nps.gov/blog/condition-assessments-tips-for-historic-building-owners/#:~:text=Condition%20Assessments%3A%20Tips%20for%20Historic%20Building%20Owners,-Posted%20by%20Ed&text=Condition%20Assessments%20are%20a%20holistic,their%20structural%20and%20Material%20condition.>

<sup>5</sup> Bernard M. Feilden, *Conservation of Historic Buildings*, 3<sup>rd</sup> Ed. (Oxon, UK: Architectural Press/Taylor & Francis Group, 1994), 205-216.

<sup>6</sup> ACI 506.4R-94 – Guide for the Evaluation of Shotcrete, (Farmington Hills, MI: American Concrete Institute, 1994), 3.

<sup>7</sup> The following cameras were used in this assessment: Phone Camera of Samsung Galaxy A20 – Camera 13MP (F1. 9)+5MP (F2. 2); for Drone photography – DJI Mavic Pro – FOV 78.8 26 mm Len; and for architectural and other photography two specific cameras were used: Canon EOS Rebel T5 Digital SLR Camera and a Nikon D850-DSLR – 24-70 mm with f2.8 & 14-24 f2.8 Lens. An X-Rite ColorChecker Classic, an Anwenk 5"X7" Grey card & White Balance Card 18% were used to complement the photographic surveys. Lastly, three specific ladders were used: a small 4 ft ladder, a stepladder of 20 ft and an Extension ladder of 30 ft. The author is grateful to the generosity of Mr. Gamaliel Pérez, CEO of Gamaire Refrigeration, Inc. in Guaynabo for lending the two stepladder and extension ladder for the development of the assessment.

<sup>8</sup> The literature used for this analysis was: English Heritage – Building Environment, English Heritage – Mortars, Renders & Plasters, English Heritage – Concrete, Concrete Building Pathology – S. Macdonald, Building Pathology, 2<sup>nd</sup> Ed – Watt, ACI 201.1R-08 – Guide for Conducting a Visual Inspection of Concrete in Service, ASTM C125-19 – Standard Terminology Relating to Concrete and Concrete Aggregates, ACI CT-18 – ACI Concrete Terminology, Conservation of Historic Buildings (1994) - Bernard M. Feilden, The Investigation and Repair of Historic Concrete – ICOMOS Australia, & Historic Concrete in Scotland Part 2: Investigation and Assessment of Defects. See the Bibliography for a more detailed list of sources.

<sup>9</sup> NSW Heritage Office, "The Investigation and Repair of Historic Concrete," (New South Wales, Australia, May 2003), 5.

<sup>10</sup> As discussed earlier, the series of socio-economic policies under the PPD known as Operation Bootstrap along the growing prosperity after WWII, brought a boom in the Construction Industry between 1950s and 1960s. The two Cement factories in the Islands used locally sourced lime, aggregates and other materials. This was key in the development a local strong concrete industry.

<sup>11</sup> As noted in ASTM C150-56, chemical requirements for Portland Cement Type I are a maximum of: 5% Ferric oxide (Fe<sub>2</sub>O<sub>3</sub>); 2.5% of Sulfur trioxide (SO<sub>3</sub>) when 3CaO·Al<sub>2</sub>O<sub>3</sub> is 8% or less, and 3% when 3CaO·Al<sub>2</sub>O<sub>3</sub> is more than 8%; 3% of loss on ignition; and 0.75% of insoluble residue. See ASTM C150-56 – Standard Specification for Portland Cement (West Conshohocken, PA: American Society for testing Materials, 1956), 2.

<sup>12</sup> The Feb 1961 specs mention the following directions for the application of stucco in exterior and interior concrete surfaces (cast-in-place): 3/8-inch-thick, one coat job; and for exterior and interior masonry: 3/8-inch-thick, two coat job. The specifications changed in the April 1961 request for bidders. Ibid.

<sup>13</sup> ACI CT-18 defines finish coat as "final exposed coat of plaster or stucco." Also, for decades, the priests, the congregation and people around the town has mentioned that Klumb added a metallic aggregate to give the dome some color. Dr. Rosa Otero (2005) mentions in her Dissertation: "During my conversation with the church's catholic priest (unidentified priest - Jan 9<sup>th</sup>, 1998), he commented on the architect's intention to apply some metal additives to the cement finish mix. The metal aggregate would have oxidized and would have given the church an entirely different aspect. Nevertheless, metal particles were never added to the mix, perhaps for economic reasons." The forensic investigation confirmed the presence of a ferrous metallic aggregate in the dome stucco. See ACI CT 18- Concrete Terminology, (Farmington Hills, MI: American Concrete Institute, 2018) & Rosa Otero, "Permeable Walls and Place Recognition in Henry Klumb's Architecture of Social Concern" (Ph.D. Diss., University of Pennsylvania, 2005), 264.

<sup>14</sup> "Puerto Rico and the U.S. Virgin Islands," State Climate Summaries 149-PR, NOAA National Centers for Environmental Information (Washington, DC: National Oceanic and Atmospheric Administration, U.S. Department of Commerce, 2019), accessed on April 20<sup>th</sup>, 2020, <https://statesummaries.ncics.org/chapter/pr/>

- 
- <sup>15</sup> *Solar Radiation Data Manual for Buildings*, (Golden, CO: National Renewable Energy Laboratory, Midwest Research Institute, September 1995), 190.
- <sup>16</sup> Watt in *Building Pathology* defines three specific types of weathering: Physical Weathering by climatic conditions, Chemical weathering which induces processes such as carbonation, oxidation, breakdown of chemical bonds, and Organic Weathering which are chemical and mechanical processes caused by plants and animals. For a in depth discussion see David S. Watt, *Building Pathology – Principles and Practice*, 2<sup>nd</sup> Ed. (London, UK: Wiley-Blackwell, 2008), 107-108.
- <sup>17</sup> Susan Macdonald, ed., *Concrete Building Pathology* (London, UK: Wiley-Blackwell, 2002), 196-201.
- <sup>18</sup> Jana, “Concrete Petrography...,” 2.
- <sup>19</sup> Watt, *Building Pathology*... 125.
- <sup>20</sup> Herb Nordmeyer, *The Stucco Book: The Basics*, (Castroville, TX: Nordmeyer LLC, 2012), 85 & 220.
- <sup>21</sup> Macdonald defines Shrinkage as the “Contraction of the cement paste as it hardens, due to loss of moisture and changes to the paste’s internal structure. Some shrinkage is non-reversible due to these changes, while reversible shrinkage occurs as the concrete becomes wet in service and then dries again. Some materials that might otherwise be used as aggregates should be avoided if they are found to be ‘shrinkable’, as this property may damage the concrete in service.” Macdonald, *Concrete Building Pathology*... 304.
- <sup>22</sup> Watt, *Building Pathology*... 114
- <sup>23</sup> Pender, Ridout and Curteis, *Practical Building Conservation*... 187.
- <sup>24</sup> Macdonald defines Corrosion as the “‘Rusting’ or the formation of iron oxides and other compounds by electrolytic action when steel is exposed to water and oxygen. Corrosion is aggravated by other aggressive agents such as acids and chlorides. Rust occupies a larger volume than the original iron, and consequently can cause cracking and spalling in the surrounding concrete.” See Macdonald, *Concrete Building Pathology*... 302.
- <sup>25</sup> Conversation with Puerto Rican engineer José “Pepe” Izquierdo, past president of the American Concrete Institute- ACI (2003) on July 8<sup>th</sup>, 2020. The Engineer also mentioned that buildings of the west side of the islands are less exposed to these winds, which leads to fewer corrosion reinforcement issues.
- <sup>26</sup> Watt, *Building Pathology*... 111.
- <sup>27</sup> *Ibid.*, 109.
- <sup>28</sup> Héctor Morillas, Fernando França de Mendonça Filho, Hannelore Derluyn, Maite Maguregui, David Grégoire, Juan Manuel Madariaga, “Decay processe in buildings close to the sea induced by marine aerosol: Salt depositions inside construction materials,” *Science of the Total Environment* 721 (2020), 2.
- <sup>29</sup> *Ibid.*
- <sup>30</sup> Watt, *Building Pathology*... 142-143.
- <sup>31</sup> Kyle Normandin states that this phenomenon is common “...because the modern movement sought to achive a formal and pristine clarity that relied upon an absence of surface relief...” See Kyle Normandi, “Physical Conservation Challenges Facing Modern Architecture,” in Kyle Normanding and Susan Macdonald, eds., *Experts Meeting: A Colloquium to Advance the Practice of Conserving Modern Heritage*, Getty Conservation Institute (March 6-7, 2013): 45.
- <sup>32</sup> Kyle Normandin states that “The modern aesthetic also contributed to air and water infiltration problems because the delicate thermal detailing of the envelope of the building had virtually no redundancy and thus allowed air and water to migrate easily through its thin skin. Vapor barrier systems emerged conceptually in the 1940s, while sealants did not come into existence until the end of the 1950s. The combined effect of the use of thin forms, the fragility of the materials, and the vulnerability to air and water infiltration was that the building assembly and its individual material components typically did not weather elegantly. The many Modern era buildings that exhibit these problems provide us with an opportunity and a challenge to continue research into new technologies for conservation, and perhaps leading us to devote more rigorous attention to maintenance programs that may lessen the future need for repair of and intervention to the historic building fabric.” *Ibid.*
- <sup>33</sup> Engineer Izquierdo also mentioned that contractors usually comply with curing practices while working on a Federal projects which are more rigorous following ACI and ASTM standards. He also mentioned that a current informal practice by contractors in the Islands on curing flat roofs consists on flooding the roof with 4 to 5 inches of water.
- <sup>34</sup> In this sense, two specific studies from 1964 and 1971 developed in Puerto Rico started to provide a new framework that is still incomplete today. Also, the ACI Committee 605 developed the ACI 605-59 ‘Recommended Practice for Hot Weather Concreting’ in 1959. Still, the proposed revisions of ACI Committee 305 in 1971 caught far more attention. The revision was published in the ACI Journal in July 1971. See I. Martin and E. Olivieri, “Curing of Concrete in Puerto Rico,” (Mayaguez, PR: Colegio de Agricultura y Artes Mecánicas,

---

Universidad de Puerto Rico, 1964); Martinez M. R., "Correlation Between the Strength of Standard Molded Cylinders and Small Drilled Concrete Cores Cured Under Field Conditions," Publication ICO-R101 (Mayaguez, PR: Construction Institute, 1971), & "Proposed Revision of ACI 605-59: Recommended Practice for Hot Weather Concreting," *ACI Journal*, (Detroit, MI: American Concrete Institute): 489-503.

<sup>35</sup> For example, issues in the hydration process which concrete should be controlled to a certain temperature to prevent shrinkage and other issues, is difficult in hotter climates since the exterior temperature can affect negatively the hydration process.

<sup>36</sup> R. Huyke-Luigi, "SP 139-10 - Strength of Concrete Cured Under Various Conditions in Tropical Climates," in Cameron MacInnis, ed., *SP-139: Durable Concrete in Hot Climates*, (San Juan, PR: The International Symposium on "How to Produce Durable Concrete in Hot Climates," September 1993), 170.

<sup>37</sup> The Archdiocese of San Juan, which oversees the other dioceses in the islands filed for bankruptcy in 2018 and the Del Carmen Church serves a working-class community. The lack of financial resources for the institution's needs, including maintenance and minor repairs is alarming.

<sup>38</sup> Elevation 9 which is the roof slab is not part of these 27 elevations.

<sup>39</sup> ACI 201.1R-08- Guide for Conducting a Visual Inspection... 3.

<sup>40</sup> ACI CT-18 defines hairline crack as "a concrete surface crack with a width so small as to be barely perceptible." For the purposes of the conditions glossary and this assessment hairline crack is, slight crack is, large crack is...

<sup>41</sup> Craze cracks - fine random cracks or fissures in a surface of plaster, cement paste, mortar, or concrete. ACI CT 18- Concrete Terminology... 33.

<sup>42</sup> Henry and Stewart, *Practical Building Conservation*... 196.

<sup>43</sup> Watt defines Sulphate attack as "(typically of calcium, magnesium and sodium) are naturally present in the ground, groundwater and various building materials, and arise from industrial pollution. When such salts meet cement-based mortars, renders and concrete, a reaction occurs between the sulphates and one of the four main components of cement (tricalcium aluminate) resulting in formation of ettringite (metastable compound)." Watt, *Building Pathology*... 123.

<sup>44</sup> ACI 201.1R-08- Guide for Conducting a Visual Inspection of Concrete in Service, (Farmington Hills, MI: American Concrete Institute, 2008), 7.

<sup>45</sup> Alison Henry and John Stewart, *Practical Building Conservation: Mortars, Renders and Plasters* (Historic England, 2011), 188.

<sup>46</sup> ACI 201.1R-08- Guide for Conducting a Visual Inspection... 8, & ACI CT 18- Concrete Terminology... 57.

<sup>47</sup> Henry and Stewart, *Practical Building Conservation*... 189.

<sup>48</sup> Adapted from the ACI CT-18 definition.

<sup>49</sup> ACI 201.1R-08- Guide for Conducting a Visual Inspection... 11.

<sup>50</sup> Henry and Stewart, *Practical Building Conservation*... 196.

<sup>51</sup> ACI CT-18 defines Alkali-silica reaction as "the reaction between the alkalis (sodium and potassium) in portland cement and certain siliceous rocks or minerals, such as opaline chert, strained quartz, and acidic volcanic glass, present in some aggregates." Macdonald adds that Soluble silicates in the aggregates react and form silica gels. These gels absorb water and expand resulting in 'map cracking' effect and efflorescence on the gel. See ACI CT 18- Concrete Terminology... 3, & Macdonald, *Concrete Building Pathology*... 148.

<sup>52</sup> Watt, *Building Pathology*... 105.

<sup>53</sup> "Puerto Rico and the U.S. Virgin Islands," State Climate... & *Fourth National Climate Assessment* (Washington D.C.: U.S. Government Publishing Office, 2018), 819-840.

<sup>54</sup> In Puerto Rico sea level has been recorded since 1962. From the period of 1962 to 2017, sea level increased 0.08 inches annually. See "Puerto Rico and the U.S. Virgin Islands," State Climate...

<sup>55</sup> Rasheeduzzafar and M.G. Ali, "SP 139-2-Effect of Temperature on Cathodic Protection Criterion for Reinforced Concrete Structures" in Cameron MacInnis, ed., *SP-139: Durable Concrete in Hot Climates*, (San Juan, PR: The International Symposium on "How to Produce Durable Concrete in Hot Climates," September 1993), 21.

## CHAPTER 5

### Materials Characterization

The preceding chapters have focused on the historical and technological background of the Del Carmen Church: intentions and motivations behind Henry Klumb's work and an overall understanding of mid-century concrete and stucco, as well as a field survey of the existing conditions of the church. Since the original exterior of the Church was unpainted Portland cement stucco, this chapter will focus on the examination and characterization of the exterior skin through Physico-chemical analysis of selected samples from the cement stucco and the concrete substrates. Microscopy and instrumental analysis provided valuable information about the composition and microstructure of these materials. These include petrography, microchemical spot test, salt content, carbonation testing, x-ray diffraction (XRD), scanning electron microscopy with energy dispersive X-Ray spectroscopy (SEM-EDS), and micro-drop water absorption testing.

Instrumental analyses complement and aid in obtaining "...the information needed for the critical evaluation of historic structures."<sup>1</sup> All these analyses are applied in the investigation of concrete and cementitious materials since they aid in the identification of the mix ingredients and proportions, in identifying the quality of workmanship, and the diagnosis of the causes of defect, distress, and deterioration of the materials. Furthermore, they help the decision-making processes for prospective interventions and conservation treatments in a historic building. There is a wide range of industry-related testing for cementitious materials from the ASTM, ACI, and the International Concrete Repair Institute (ICRI). Still, a vast majority of these tests focus on pre or post-construction performance and non-conservation repairs and usually require large sample sets that are destructive by nature.

To achieve an effective testing strategy at the Del Carmen Church, proper archival research, recording, and documentation of the conditions were performed first. This process helped to tailor the research questions and identify the material analyses needed to complete a fuller understanding of the building's original appearance and its alterations and deterioration over time. The primary focus of this investigation is to characterize the Portland cement stucco finishes, their composition, and deterioration patterns to recommend suitable treatments for the prospective cleaning and overall restoration of the exterior. To identify which analyses were ideal for this investigation, the testing strategies aimed to focus on the following specific research questions:

- What is the composition of the different cementitious stuccos, and how they were applied to the surface?
- How do composition and application methods, design, and construction influence the performance of modern historic cement plaster surfaces in a tropical coastal environment?
- What does deterioration look like at the micro-level? What Physico-chemical alterations are evident that affect performance?
- What coatings and other surface treatments were employed on the exterior over the years? What effect do these have on the building?

To answer these questions, the following testing program was implemented: carbonation-phenolphthalein testing, semi-quantitative salt analysis, micro-drop water absorption, thin section petrography, x-ray diffraction (XRD), micro-chemical spot tests, and scanning electron microscopy with energy dispersive x-ray fluorescence spectroscopy (SEM-EDS) on thick cross-sections.<sup>2</sup> The testing schedule was completed between January and September 2020 at the University of Pennsylvania's Architectural Conservation Laboratory (ACL), the Center for the Analysis of Archaeological Materials at the University of Pennsylvania Museum of Archaeology and Anthropology, the Center for Architectural Conservation (CAC), and the Laboratory for Research on the Structure of

Matter (LRSM)-Singh Center for Nanotechnology. For the complete testing schedule used for this research, see Appendix 7.

*Table 5.1: General Sample Schedule*

Instrumental Analysis	Properties	Samples Used	Date Performed
<i>Stereomicroscopy</i>	Preliminary characterization of bulk samples	All Samples	Jan 26 <sup>th</sup> , 2020 at ACL
<i>Carbonation – Phenolphthalein</i>	Qualitative identification (preliminary) of carbonation rates	All 8 Samples	Jan 12 <sup>th</sup> & 14 <sup>th</sup> , 2020 On-site
<i>Semi-Quantitative Salt Analysis</i>	Identification of deleterious salts affecting the stucco and concrete	All 8 Samples	Aug 30 <sup>th</sup> , 2020 at CAC
<i>Micro-drop absorption test</i>	Assess approximate differences in water absorption rates of the stuccoes.	7 Samples (1A, 1B, 2A, 2B, 3A, 4 & 5)	Aug 20 <sup>th</sup> , 2020 at CAC
<i>Micro-chemical spot test</i>	Characterization – Identify the type of metallic-ferrous aggregate (composition) in dome stucco.	1 Sample (2A)	Aug 20 <sup>th</sup> , 2020 at CAC
<i>Polarized Light Microscopy (PLM)/ Petrography</i>	Characterization of stucco composition, workmanship and microstructure Identification of deleterious components	12 Samples (1A-1, 1A-3, 1A-5, 1B, 2A-1, 2A-2, 2A-3, 2B, 3A, 3B, 4-1, 5)	July 29 <sup>th</sup> – Aug 19 <sup>th</sup> , 2020 at CAAM
<i>X-Ray Powder Diffraction Spectrometry (XRD)</i>	Characterization of mix components (composition) Identification of mineral and crystal phases - deleterious salts and other components	All 8 Samples	August 27 <sup>th</sup> , 28 <sup>th</sup> & 31 <sup>st</sup> , 2020 at LRSM
<i>Scanning Electron Microscopy - Energy Dispersive X-Ray Spectroscopy (SEM-EDS)</i>	Characterization – Identification of metallic-ferrous aggregate in dome stucco & paint (composition) Identification of mineral and crystal phases - deleterious components	2 Samples (2A & 3A)	Aug 7 <sup>th</sup> & Sept 8 <sup>th</sup> , 2020 at LRSM

## 5.1 Sampling Methodology

After completing the Conditions Assessment, eight (8) specific samples were taken from different locations on the exterior of the Del Carmen Church in January 2020.<sup>3</sup> These samples were selected from different areas that would yield the most promising results for analysis, considering the various stucco applications, concrete substrates, and visible deterioration patterns. Following the best practices, these samples were taken from hidden and non-accessible areas of the building, specifically in the dome and walls of Elevations 8, 16, 3, Column B, and Panel 3 in Elevation 6B. Accessibility limitations to areas such as the upper parts of the dome were also considered before selecting the final sampling areas.

Since there were some severely deteriorated areas of the stucco finishes, those samples were collected first (Samples 1A). Sample 1B was chosen to examine the bond with the poured-in-place concrete substrate and the current condition of the sprayed-stucco. Samples 2A & 2B were selected to identify the types of stucco finishes used in the dome, their composition, and current conditions. Sample 3A was chosen from an exposed area of Column B to identify its current conditions, including possible salts. Sample 3B was selected from a non-exposed hidden area for characterization and to compare with current conditions with Sample 3A. Samples 4 were selected from an exposed and deteriorated area of Elevation 3 to identify current deleterious conditions, characterize the type and composition of the stucco finish. Lastly, Sample 5 was selected from a hidden area of the Precast panels to identify possible stucco coatings, composition, and deterioration issues.

An electric hand concrete saw was used to remove the samples. Each Sample was then placed into a plastic bag with an identification number, date, and time. The locations were marked on the full-size image maps and noted on a sampling sheet, with



a description of the area sampled along with photographs taken. For a summary of the location for each Sample, see Appendix 6.

## **5.2 Instrumental Analyses**

### *5.2.1 Stereomicroscopy of Bulk Samples*

Before conducting any advanced analysis, a Leica MZ16 stereomicroscope was used for preliminary or gross sample examination, noting physical characteristics such as color, texture, and general deterioration. Stereomicroscopes are used in the analysis of concrete and cementitious materials to help in the identification of aggregates, air voids, cracks, and other features.<sup>4</sup> For this research, a general stereomicroscope examination aided in the process of selecting samples for further study. Observations were made at magnifications of 1.0x to 1.25x.

General observations include deteriorated and non-deteriorated areas (in the process) and differences in porosity on Samples 1A. Good bonding was observed between the stucco and poured-in-place concrete substrate in Sample 2B. A significant amount of fine aggregate was also observed in Sample B compared to other samples and less porosity in Samples 4; and few visible pores and no visible stucco coats were observed in Sample 5. Samples 2A and 3A showed considerable deteriorated areas.



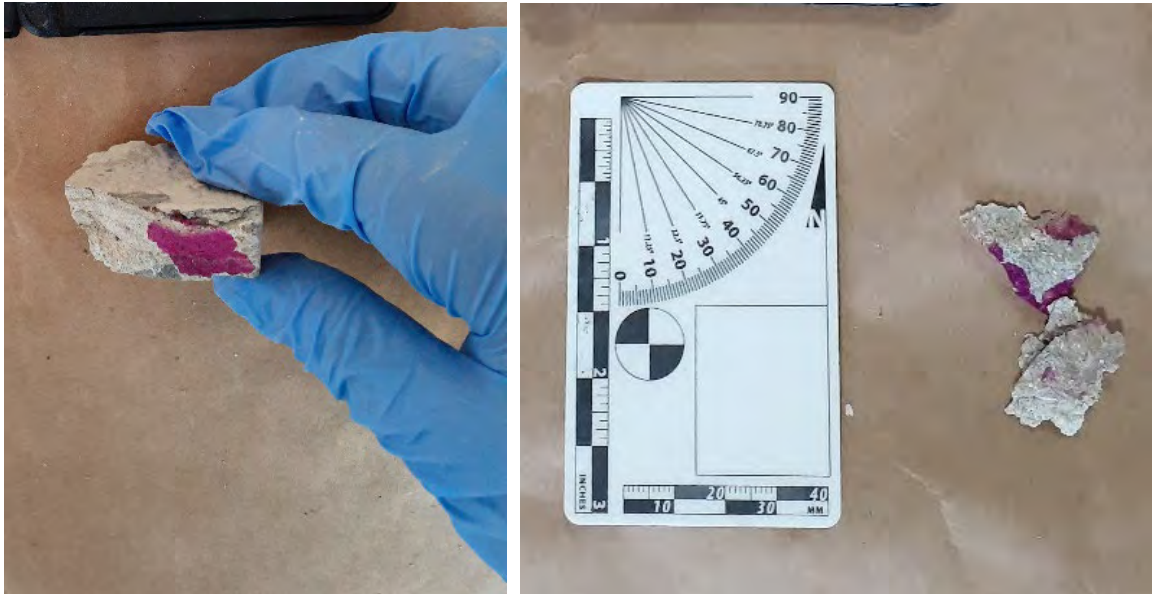
*Figs. 5.1, 5.2, 5.3, 5.4, 5.5 & 5.6 – From left to right, Samples 1A (1A-1), 1A (1A-5), 2A (2A-1), 2B, 4 & 5. All cross-sections were examined at 1.0X, except 2A which was at 1.25X and Sample 5 at 0.71X. Photos by the Author.*

### 5.2.2 Carbonation

The carbonation of concrete and cementitious materials is a slow and continuous process, which "leads to a decrease of the pH-value of the cement paste."<sup>5</sup> Carbonation occurs when components of cementitious materials such as calcium, sodium, and potassium hydroxides ( $\text{Ca}(\text{OH})_2$ ,  $\text{NaOH}$ , and  $\text{KOH}$ ) came in contact with carbon dioxide ( $\text{CO}_2$ ) from rainwater, air, and environmental pollutants, causing a reduction in alkalinity. As a slow process, carbonation penetrates the concrete or stucco over time, affecting its alkaline protective environment for steel rebar and eventually leading to reinforcement corrosion and concrete spalls.<sup>6</sup>

In this research, phenolphthalein, a chemical indicator ( $\text{C}_{20}\text{H}_{14}\text{O}_4$ ), was used to assess the carbonation rate of the concrete and stucco samples at the Del Carmen Church qualitatively. The phenolphthalein solution reacts with alkaline cementitious materials ( $\text{pH} > 9$ ), and it turns bright pink. Phenolphthalein is colorless in neutral and acidic materials ( $\text{pH} < 8.3$ ).<sup>7</sup> One limitation of this specific test is that the results must be interpreted along with other analyses such as petrography.<sup>8</sup>

For this simple test, all eight (8) samples were analyzed. Since freshly exposed alkaline concrete/hardened stucco is required for optimal results, the samples were tested onsite approximately 30 mins after their collection. The phenolphthalein solution consisted of 1% phenolphthalein and 95% ethanol. The process consisted of applying 1 or 2 drops of the solution to the samples. Photographs are taken before and after the chemical reactions on the samples. After the test, the results indicate that 6 out of 8 samples showed full carbonation. Samples 2A showed partial and no carbonation (on the substrate), and the Sample 4-Stucco showed no carbonation at all. See Appendix 10.



*Figs. 5.7 & 5.8 – Samples 2A & 4 showing uncarbonated areas after the application of the Phenolphthalein chemical indicator. Photos by Author.*

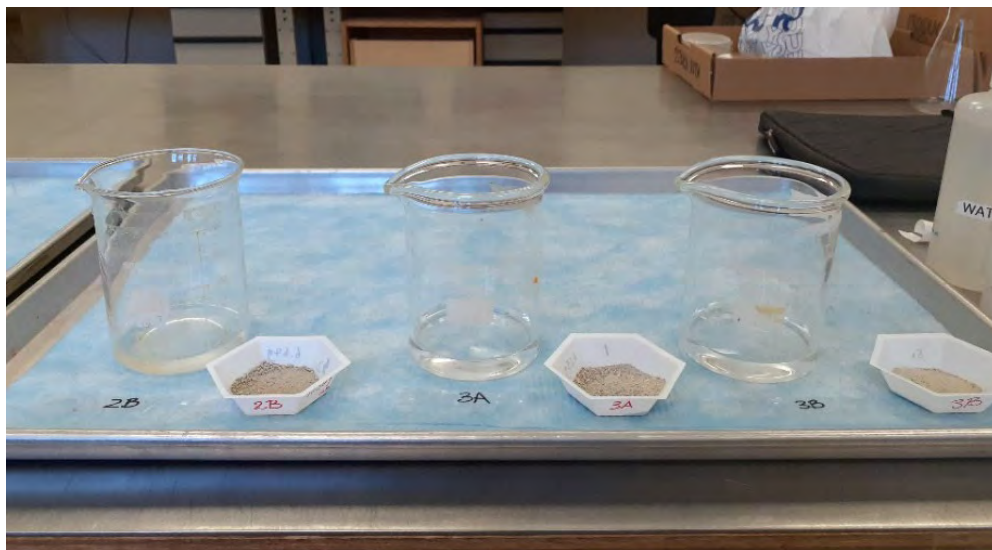
### 5.2.3 Semi-Quantitative Salt Analysis

Salt efflorescence was not visible on the surfaces during field investigation. However, because of the site's tropical-marine environment, one of the objectives of this research was to identify the presence of deleterious salts on the exterior stucco finishes. The presence of soluble salts in cementitious materials can attract additional moisture, salt scaling, cracking, and surface spalling, as discussed in Chapter 4. This phenomenon is common in coastal areas.<sup>9</sup> For this simple test, Semiquantitative Merk MQuant™ strips were used to detect the presence of soluble salts such as chlorides (Cl<sup>-</sup>), nitrates (NO<sub>3</sub><sup>-</sup>), and sulfates (SO<sub>4</sub><sup>2-</sup>). The soluble salts' concentrations are measured semiquantitatively by visually comparing the test strips reaction zones with the color rows of a color scale. To identify the prospective risks of salts in concrete and stucco, "it is necessary to determine whether the salt content is likely to increase or remain the same."<sup>10</sup>

For salt testing, several fragments from the eight (8) samples were ground to a powder with a mortar and pestle to ensure that all salt is dissolved in water. Between 4 g

and 10 g of powdered Sample (depending on the Sample) was added to a beaker with 50 mL deionized water. The water and powder were agitated by hand and with a magnetitic stirring hotplate for five (5) minutes. The salt strips were dipped into the water after the powder appeared to be dissolved. Water excess was shaken off from the strips and were left to dry following the manufacturer's specifications. The observations were photographed and noted.

The results indicated that Samples 1A, 2A, 2B & 4 showed high sulfate content. Samples 1A & 3B showed low chloride content, while Samples 2A, 2B, and 1B showed very low chloride content. Only samples 1A & 3B showed very low nitrate levels, while the rest of the samples indicated no presence of nitrates. The deionized water in Samples 3B and 5 turned pink after the powder's addition. See Appendix 13 for specific data.



*Fig. 5.9* – Preparation for the salt analysis included 50 mL water and powdered samples up to 10 g. Photo by the Author.

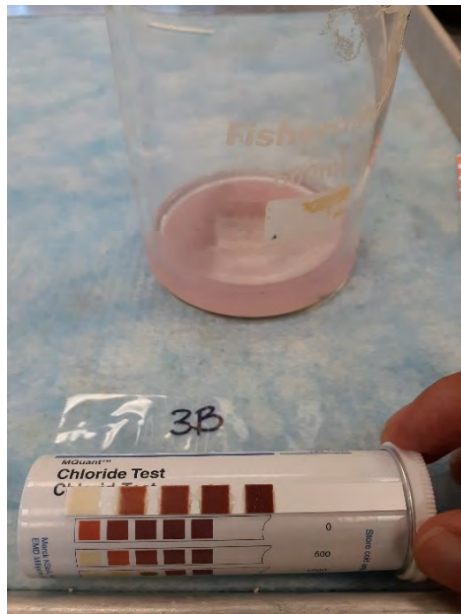
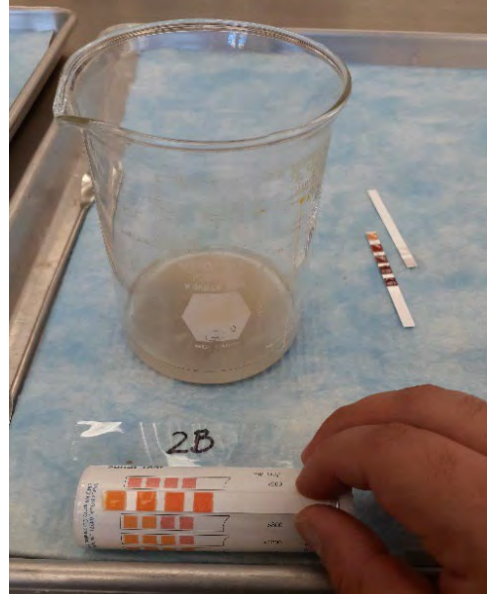


Fig. 5.10, 5.11 & 5.12 – Sample preparation process included dissolving the powder in deionized water. In samples 3B and 5 the deionized water turned pink after adding the powdered samples and after stirred by hand for 5 mins. Photos by the Author.

#### 5.2.4 Microdrop water absorption test<sup>11</sup>

An approximate assessment of the porosity, difference in surface conditions, and the samples' absorption behavior can be determined by the absorption time. The test consists of placing deionized water droplets (between 1 or 2 for this research) of approximately 4  $\mu\text{L}$  on a regular stable/flat surface of the samples while measuring the time it takes to be absorbed/evaporated.<sup>12</sup> The same number of drops are placed on an

unpolished glass plate as a control. The time each droplet takes to disappear in both Sample and glass plate are measured in seconds with a chronometer. For this experiment, 30 mins (1800 secs) was set as the standard drying time for each Sample. In the process, I observed that at 30 mins, the samples were already dry, but the drops were still present on the glass plates. The faster the absorption, the greater permeability of the Sample. The results of the test are calculated as:

$$\frac{\text{Time drops disappear on Sample (Secs)}}{\text{Time drops disappear on Glass plate (Secs)}} \times 100 = \%$$

The test result is the ratio of the time it takes for the drops to disappear to the time it takes for the drops to disappear on the glass plate, expressed as a percentage.

The test showed that the Shotcrete/sprayed stucco samples have higher absorption rates -between 47 seconds to 3 mins (2.6% to 5.5%) than the troweled stucco samples except for Sample 3A, which took a little longer -3 mins 10 secs (10%). The dome stucco with the iron filings and the troweled stucco on the masonry wall (Samples 2A & 4) took between 10 mins and 28 mins, respectively, showing a lower absorption rate (between 34.3% to 95.9%). The precast wall sample (Sample 5) also showed a high absorption rate with 45 seconds (between 2.5% and 6.6%).<sup>13</sup> See Appendix 11 for specific data. It is essential to mention that there are no standard test procedures for permeability on shotcrete/sprayed stucco.<sup>14</sup>

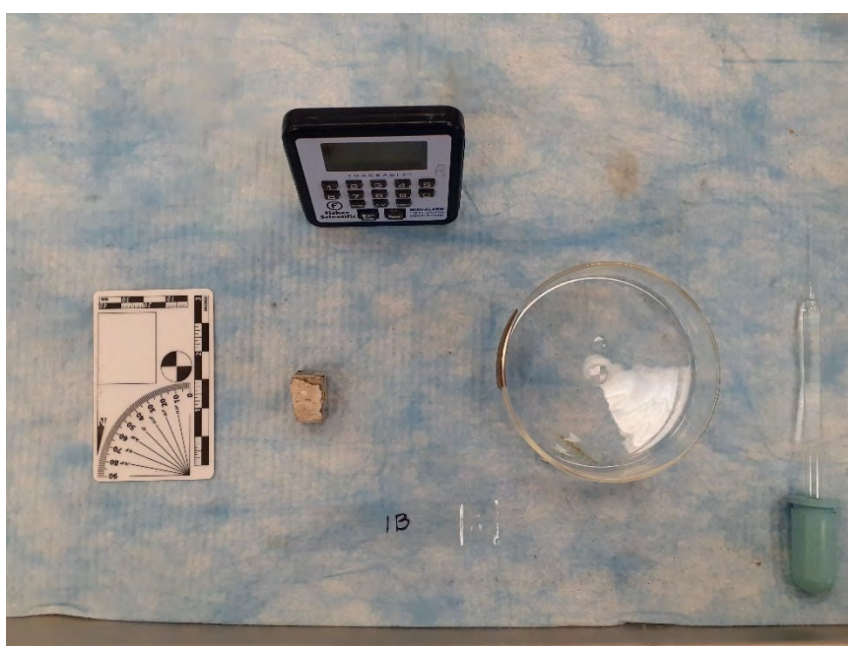
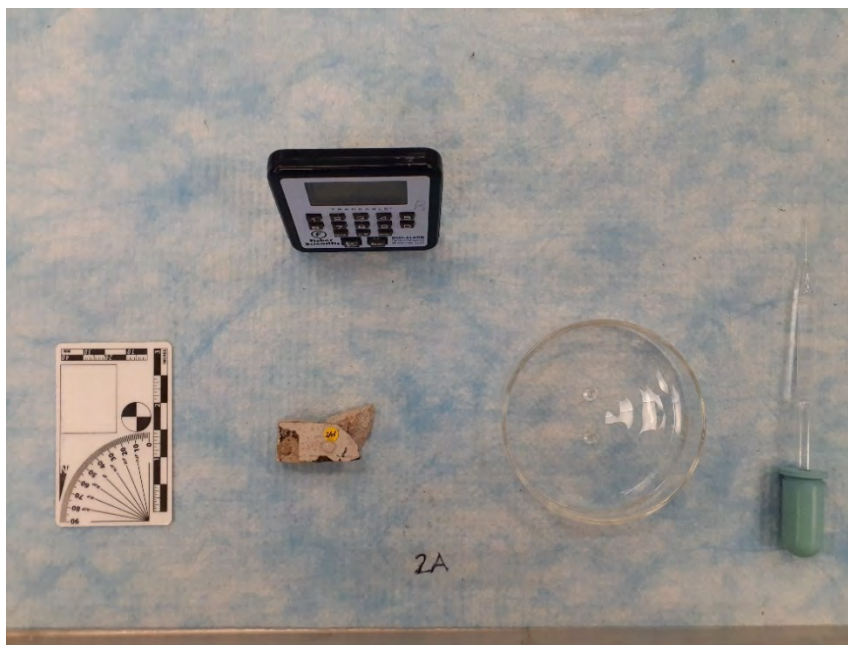


Fig. 5.13 & 5.14 – Drops were applied to samples and glass plates (as control). The time was measured with a chronometer. See Samples 2A & 1B. Photos by the Author.

### 5.2.5 Micro-chemical spot test

The chemical spot test is a practical and straightforward qualitative test for determining the constituents of materials, in this case, identifying metallic ions. It can be done either as a simple onsite test or as an alternative to more expensive tests. The



purpose of this test was to make a preliminary identification of the ferrous-metallic aggregate/filings in the Portland cement stucco in Sample 2A by conducting chemical spot tests. For the process, the samples were examined to identify the color of the metal and corrosion products and determined if these filings were magnetic. The archival research revealed how Klumb used metallic filings for waterproof stuccoes on different projects between the 1950s and 1960s. The chemical spot test selected was to identify iron filings (Fe<sup>3+</sup>).

A chunk of the Sample was crushed with mortar and pestle to gather the filings for further analysis. The metallic aggregate pieces were selected for further examination with tweezers and placed on a glass plate. The metallic filings were first dissolved with a droplet of hydrochloric acid solution (HCl), then heated in a hot dish, and redissolved with two deionized water droplets. A drop of potassium ferrocyanide solution (C<sub>6</sub>FeK<sub>4</sub>N<sub>6</sub>) was added and turned to an intense Prussian blue (C<sub>18</sub>Fe<sub>7</sub>N<sub>18</sub>). Lastly, a droplet of ammonium thiocyanate solution was added to the previous solution, which produced a blood-red color due to the formation of Fe(SCN)<sub>x</sub><sup>(+3-x)</sup> ion. This last step confirmed the ferrous-metallic aggregate in Sample 2A as iron. The reaction was observed under 115x magnification with a Leica MZ15 stereomicroscope. The results of this test were completed with the results of the SEM-EDS. See Appendix 12 for additional photos.



Fig. 5.15 & 5.16 – Sample preparation for the test. Results confirmed the presence of Iron on Sample 2A. Photos by the Author.

### 5.2.6 Polarized Light Microscopy (PLM) / Concrete Petrography

The petrographic analysis of thin sections using plane and polarized light for cementitious materials is a valuable tool for the study of microstructure, identifying composition like coarse and fine aggregates, cement types, additives, and admixtures.<sup>15</sup> It is also useful for analyzing the mix of proportions, water/cement ratio, air void content, and forensic signs of deterioration mechanisms. Furthermore, when evaluating Portland cement stuccos, petrography can also help determine the number of layers and their thickness, type, and source of aggregates, binders, mineral additions, and/or pigments, as well as identifying workmanship issues.<sup>16</sup> Optical microscopy "is often recommended as a critical and primary component in the analysis of mortars" and concrete.<sup>17</sup>

The petrographic analysis uses a polarized light microscope consisting of a light source, stage, objectives, and eyepieces. As a critical instrumental technique, petrography

is generally complemented with specialized instrumental analyses such as x-ray diffractometry, SEM with an energy dispersive x-ray micro-analysis system (EDS), infrared (IR) spectrometry, and/or Raman spectroscopy.<sup>18</sup>

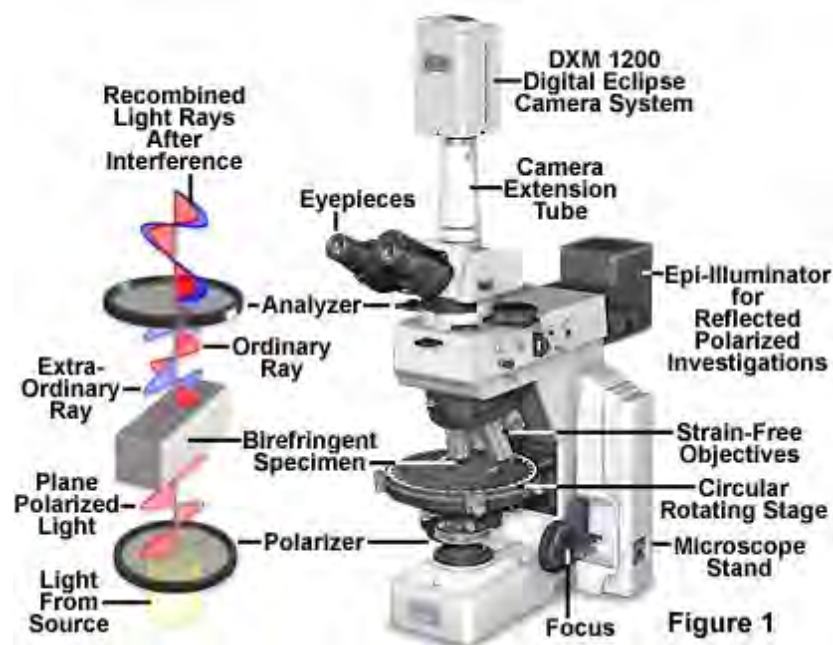


Fig. 5.17 – Configuration of a Polarized Light Microscope. Source: “Introduction to Polarized Light Microscopy,” *BW Optics*, April 4<sup>th</sup>, 2010 <http://bwoptics.com/newsend2.asp?id=7>. Accessed on February 3<sup>rd</sup>, 2020.

Polarized light microscopy was conducted to identify and confirm the material composition, physico-mechanical properties (microstructure, pore sizes, binder, aggregates), as well, as pathologies in the Portland cement-stucco at the Del Carmen Church. A full semester of training under the direction of Dr. Marie-Claude Boileau at the Penn Museum aided this analysis. First, a Leica MZ16 stereomicroscope at the ACL was used for preliminary sample examination, noting physical characteristics such as color, texture, aggregates, and deleterious patterns. The thin sections were sponsored by both the Center for the Analysis of Archaeological Materials (CAAM) and the Graduate Program in Historic Preservation and prepared by the National Petrographic Service, Inc. in Texas. After consultation with various professional concrete petrographers and sources, blue-dyed epoxy resin was selected for the thin sections to help identify porosity.<sup>19</sup> Also, oil was

used in the preparation of the thin sections to prevent the dissolution of any salts in the petrofabric. The cover-slipped samples were prepared at approximately 20-30  $\mu\text{m}$  thickness. The following twelve (12) thin sections-samples gathered from different parts of the building were analyzed:

*Table 5.2: Samples for Petrographic Analysis*

SAMPLE No.	SAMPLE LOCATION	TYPE	PETROGRAPHY - RESEARCH QUESTIONS
DCC_1A-1	Elevation 16 East Side	Stucco	ID if Sprayed Stucco/Shotcrete Properties – Flat Surface Current Condition
DCC_1A-3	Elevation 16 East Side	Stucco	ID if Sprayed Stucco/Shotcrete Properties – Rough Surface Current Condition
DCC_1A-5	Elevation 16 East Side	Stucco	Properties Current Condition - Deterioration
DCC_1B	Elevation 16, behind Column B Northeast Side	Stucco + Concrete poured-in-place Substrate	ID if Sprayed Stucco/Shotcrete Properties Current Condition Adhesion to Substrate
DCC_2A-1	Cupola-front, Elevation 8 Northeast Side	Stucco + Concrete poured-in-place Substrate	Properties – ID Metallic Aggregate Current Condition
DCC_2A-2	Cupola-front, Elevation 8 Northeast Side	Stucco + Concrete poured-in-place Substrate	Properties Current Condition - Deterioration Adhesion to Substrate
DDC_2A-3	Cupola-front, Elevation 8 Northeast Side	Stucco + Concrete poured-in-place Substrate	Properties – ID Metallic Aggregate Current Condition Adhesion to Substrate
DCC_2B	Cupola-rear, Elevation 8 Northeast Side	Stucco + Concrete poured-in-place Substrate	Comparison to Front Stucco Properties ID presence of Metallic Aggregate Current Condition
DCC_3A	Column B-rear Northeast Side	Stucco	ID if Sprayed Stucco/Shotcrete Properties Current Condition
DCC_3B	Back of Column B Northeast Side	Stucco	Properties Current Condition - Deterioration
DCC_4-1	Circular concrete block masonry wall – Elevation 3-B North Side	Stucco	ID if Sprayed Stucco/Shotcrete Properties – Comparison to other Plasters in Building Current Condition

DCC_5	Precast wall-rear, Panel #3 – Elevation 6-B North Side	Precast concrete substrate	ID Properties Current Condition
-------	---	-------------------------------	---------------------------------------

The complete analysis of thin sections was undertaken using a Zeiss Axioscope A1 at the University of Pennsylvania's Ceramics Laboratory of the CAAM located in the University Museum of Archaeology and Anthropology.



Fig. 5.18 – Examination of samples on the Polarized Light Microscope at the Penn Museum's Center for the Analysis of Archaeological Materials (CAAM). Photo by Dr. Boileau.

The petrographic analysis followed standard references from the industry such as ASTM C295 – *Petrographic Examination of Aggregates for Concrete*, ASTM C856 – *Petrographic Examination of Hardened Concrete*, ASTM C1324 – *Examination and Analysis of Hardened Masonry Mortar* & ASTM C467 – *Microscopical Determination of Parameters of the Air-Void System in Hardened Concrete*. Poole & Sims' *Concrete Petrography: A Handbook of Investigative Techniques*, 2<sup>nd</sup> Ed. (2012), and Ingham's *Geomaterials Under the Microscope* (2013) are the two primary reference texts that

complemented the report; both analyzed in then Annotated Bibliography. Photomicrographs were taken of each thin section illuminated with reflected light and polarized light. The full petrographic report covering the twelve (12) thin sections and the Photomicrographs are in Appendix 14.



Fig. 5.19 – Hand specimens and Thin Sections from Samples 1A-1 to 2A-2. Photo by the Author.



Fig. 5.20 – Hand specimens and Thin Sections from Samples 2A-3 to 5. Photo by the Author.

The investigation confirmed the existence of three (3) different stucco applications in the Del Carmen Church: traditional troweled stucco, traditional troweled stucco with

metallic-ferrous filings, and the presence of shotcrete/sprayed stucco. The shotcrete/sprayed stucco (Samples 1A-1, 1A-3, 1A-5, 1B, 2B, 3A & 3B) showed a relatively higher percentage of voids, and more non-spherical aggregate and, therefore, greater porosity and very poor compaction and a high water/cement ratio compared to the troweled stucco. A 'Dry method Shotcrete' was probably used since all these observed characteristics suggest the use of a dry mix-sprayed stucco on the Del Carmen Church. The shotcrete/sprayed Stucco also showed poorer bonding between the Stucco and concrete substrate.

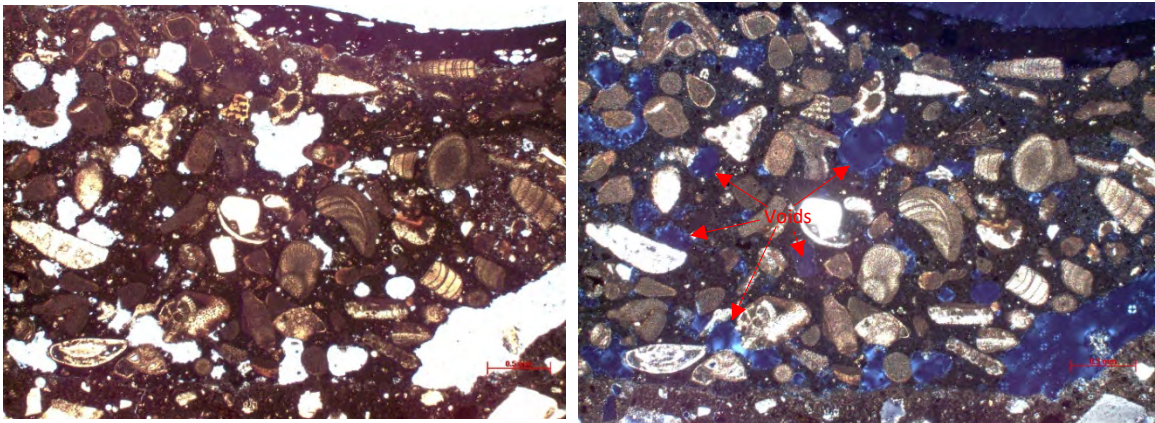


Fig. 5.22 – Sample 1B which is a sprayed/shotcrete applied Stucco showing higher porosity (note blue dye).

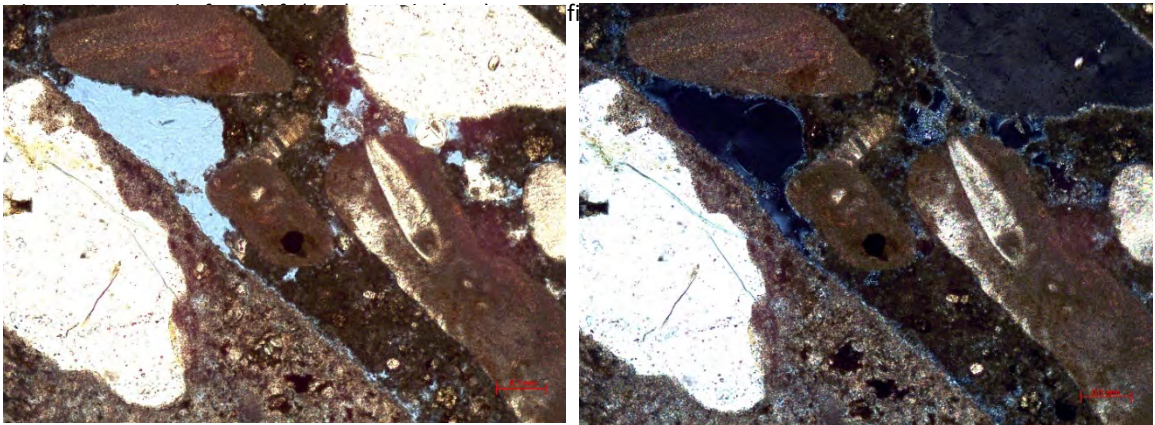
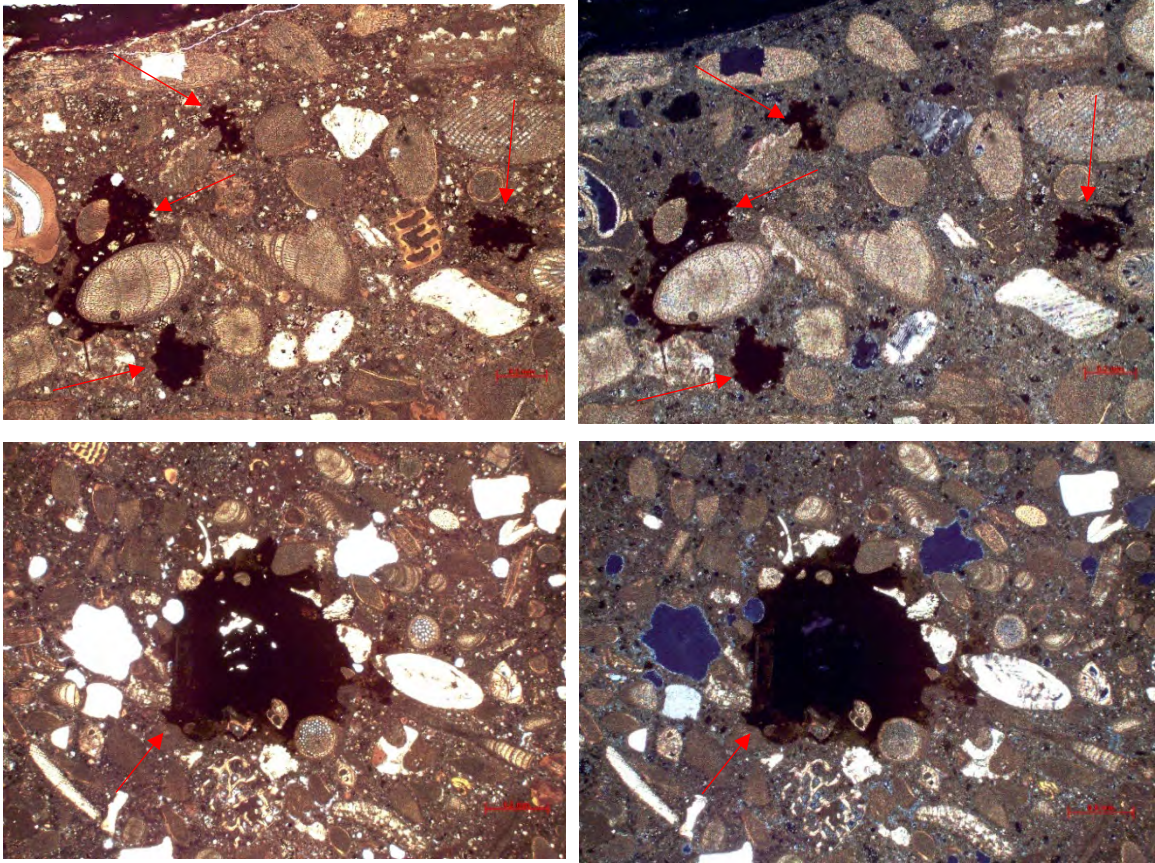


Fig. 5.23 – Sample 2B shows poor bonding between the sprayed/shotcrete stucco and the poured-in-place concrete substrate. Note the surface interface voids. Photomicrographs from left (PPL) to right (XPL), magnification at 2.5x. Photo by Author.

Both onsite investigation and petrographic analysis confirmed that the poured-in-place concrete substrates were not mechanically prepared (bush hammered or chipped) to apply the stuccos (mostly the sprayed stucco). A bonding agent/coating as a surface preparation method could not be identified on the hand specimens or the thin sections using optical microscopy, so fluorescence microscopy is recommended for this matter. The shotcrete/sprayed stucco was applied as one coat (usually 3/8-inch-thick), and the troweled stucco was applied as two layers, matching Klumb's general specifications for stucco application. The samples at the exterior structural columns (Samples 3A & 3B) showed the application of a traditional troweled, less porous stucco mix as a first coat and shotcrete/sprayed stucco as a second coat.

The investigation also provided key findings regarding the composition of Stucco. The preliminary confirmation of Ferrite phases in the Portland cement matrix shows the use of Grey Portland cement for all the stucco mixes and not White Portland cement as outlined initially.<sup>20</sup> Klumb specified the use of white silica sand as the fine aggregate for the mixes, but the petrographic analysis confirmed the use of a calcium carbonate biogenic beach sand, probably locally sourced and is composed of aragonite and calcite, both  $\text{CaCO}_3$ . The use of hydrated lime, as specified in the construction specifications, was also confirmed. A metallic aggregate with a particle size between 1.5 mm and 0.12 mm was identified in Sample 2A. The SEM-EDS and petrographic analysis showed that the metallic aggregate was only present and evenly distributed in the upper layer/coat of Sample 2A. In this sense, the compositions of the Stucco are not as outlined in Klumb's construction documents.

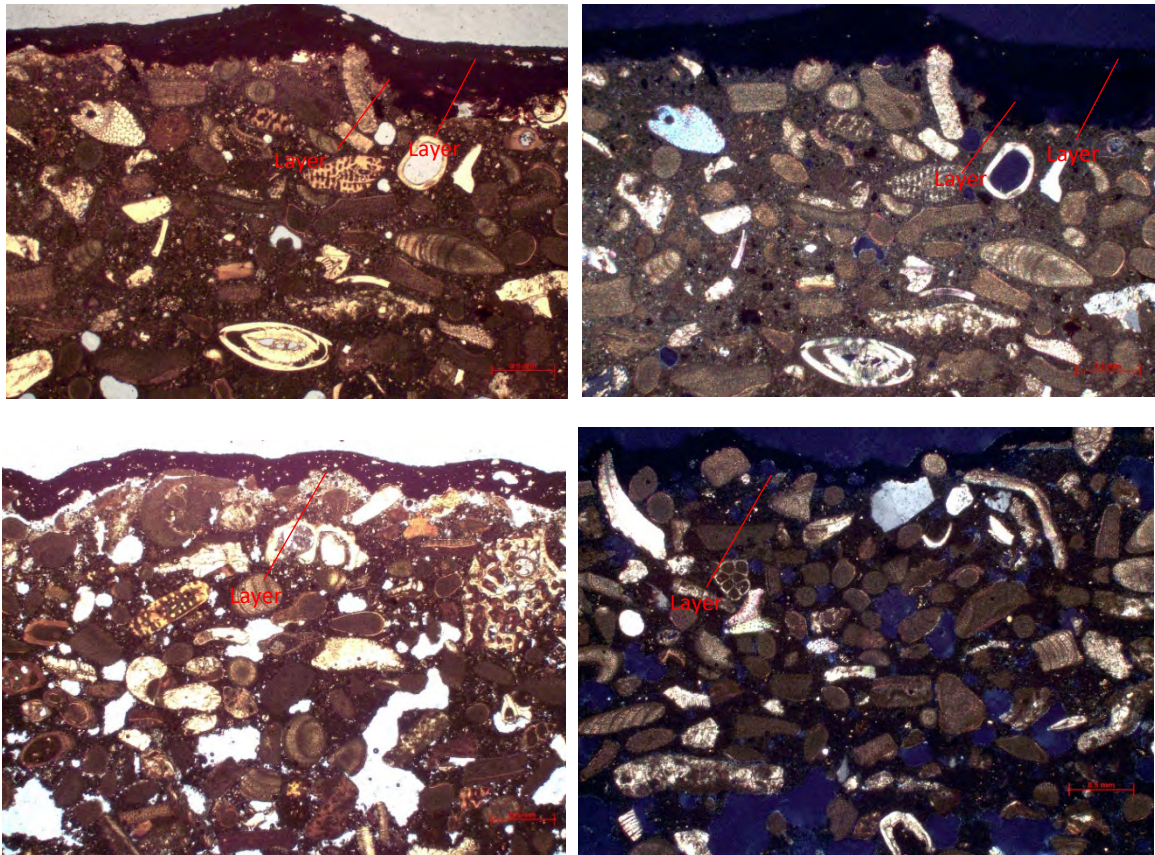




*Figs. 5.24 & 5.25 – Photomicrographs from left (PPL) to right (XPL) of the metallic ferrous (iron) filings in Sample 2A-3 at 5x magnification (Upper) and 2.5x magnification (lower). Photo by the Author.*

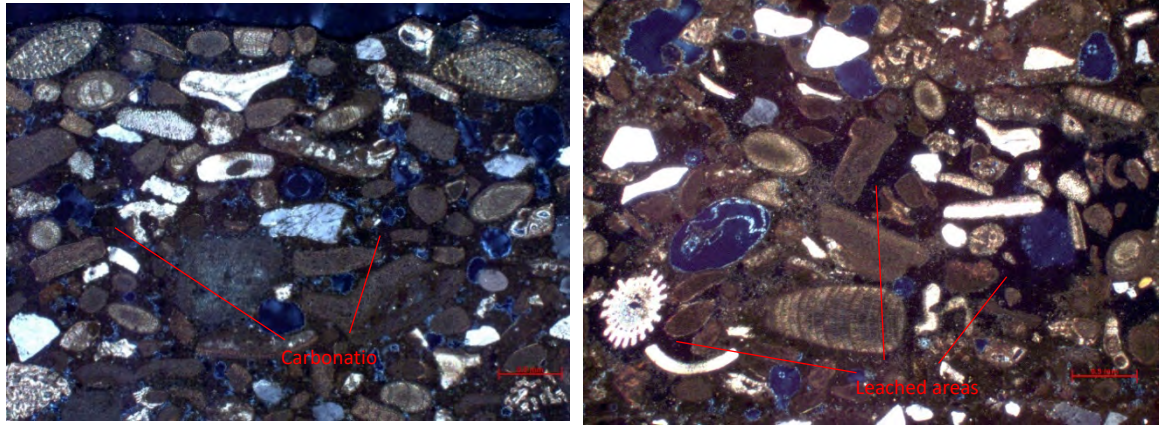
As part of the current research, surface treatments employed over the years were examined on the thin sections. Both onsite and petrographic analyses confirmed the application of between one (1) and two (2) layers of paint on the church's exterior. In the dome area, Sample 2A showed the use of an asphaltic coating and paint. Sample 5 from the precast wall showed only one layer of paint from the first painting campaign of the Church. The other areas in the building showed the confirmed application of one layer of paint. Since all the samples were taken from hidden or partially inaccessible areas, the majority showed one paint coat. Still, photos of the last decade and the onsite investigation revealed at least two-color variations on the exterior surfaces. No dirt layers were identified underneath the paint layers. The use of a pressure washer to clean the exterior surfaces

of the Church has been a common practice, and there is a chance that these cleaning campaigns removed any soiling before application.



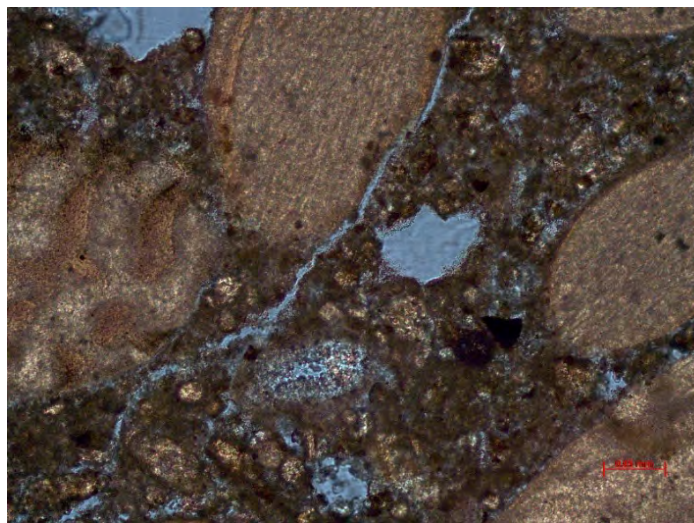
*Fig. 5.26 & 5.27 – Photomicrographs from left (PPL) to right (XPL) of Samples 2A-3 (Upper) and 1A-5 (Lower) both at 2.5x magnification. Sample 2A-3 shows two layers on the surface- one from paint and one from the asphaltic coating, while Sample 1A-5 shows only one layer of paint. Photos by the Author.*

Another important aspect of the analysis was the identification of deterioration on the stucco. The investigation confirmed carbonation on both the stucco coats and some of the substrates. The Shotcrete/sprayed stucco samples showed higher carbonation rates than the troweled stucco samples, presumably due to their higher porosity. Samples 1A-1, 1A-2, 1A-5, 1B, 2B, 3A & 3B shows full and partial carbonation on the whole Stucco. Samples 2A-1, 2A-2, 2A-3, 4 & 5 show specific leached areas. The dark uncarbonated areas are extremely fine-grained, and there is no crystal large enough to distinguish between dolomite and calcite, so a more specific identification of those leached areas would require more specialized instrumentation such as x-ray fluorescence (XRF).



*Fig. 5.28 & 5.29 – Photomicrographs of Samples 3A (left) and 2A-2 both at magnification 2.5x. In Sample 3A calcium carbonate in cement is present as clumps of crystals. As carbonation advances, those crystals form a dense texture darkening the paste and can be identified better in XPL. Sample 2A-2 shows leached areas. Photos by the Author.*

Also, shrinkage cracking, a naturally occurring process in the drying of the material, is evident. Some large cracks, as in Sample 1A-3, are the product of the sample preparation process to make the thin section. In Sample 1B, some cracks are filled with calcium carbonate deposits indicating dissolution and recrystallization of the paste.



*Fig. 5.30 – Shrinkage microcrack through the cement matrix surrounding the biogenic sand aggregate on Sample 1A-5 on PPL at magnification 20x. Photo by the Author.*

The investigation found that Sample 4-1 (Troweled Stucco from concrete masonry wall) are depleted of ettringite crystals in its voids within the Portland cement matrix, showing the possibility of delayed ettringite formation (DEF). This phenomenon occurs in concrete with high curing temperatures and where it is exposed to constant moisture

ingress. Sample 2A (Troweled Stucco with iron filings from the Dome) shows the initial formation of salt deposits in a considerable number of voids. Samples 1A (1A-1), 2B, 3A & 3B show some salt deposits and expansive secondary needle-like ettringite crystals within the matrix. These ettringite crystals were most likely formed during the hardening of concrete.<sup>21</sup> Salt deposits can also be formed as the concrete is exposed continuously to wetting and drying patterns in the harsh tropical marine environment.

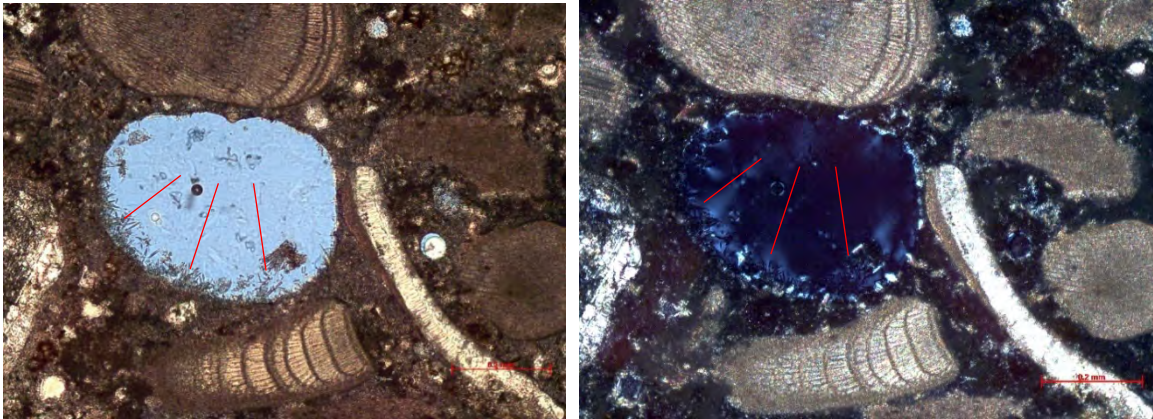


Fig. 5.31 – Photomicrographs from left (PPL) to right (XPL) of Sample 4-1 (troweled stucco) showing secondary needle-like ettringite crystals on a void. Magnification at 10x. Photo by the Author.

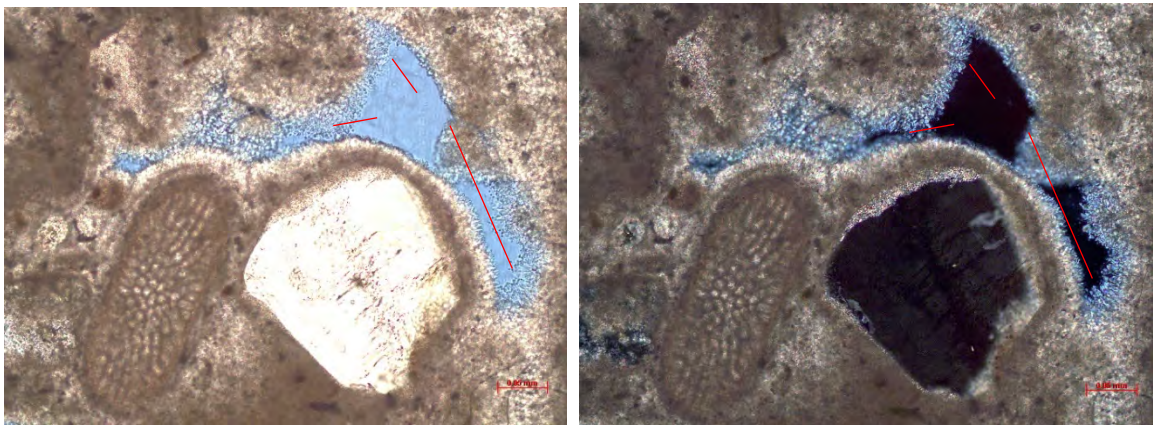


Fig. 5.32 – Photomicrographs from left (PPL) to right (XPL) of Sample 3B (sprayed/shotcrete stucco) showing salt deposits and ettringite crystals on its voids. Magnification at 20x. Photos by the Author.

### 5.2.7 X-Ray Powder Diffraction Spectrometry (XRD)

X-ray powder diffraction (XRPD) is a powerful non-destructive, and quick analytical technique used for phase identification of specific crystalline organic and inorganic compounds such as metals, pigments, ceramics, additives, binders, etc., preferred

orientation (texture) and atomic spacing.<sup>22</sup> As Wells mention, it is "arguably the most important instrumental analytical technique that can be used for determining mortar composition, particularly through the characterization of binders."<sup>23</sup> The XRD analyzes homogeneous finely ground material (powder) to determine an average composition.<sup>24</sup> The Sample is mounted and inserted into a diffractometer where software collects the data. In a powdery sample, crystalline compounds will refract light in different patterns when exposed to a monochromatic beam of X-rays that change incidence angles. In this process, the amount of diffracted x-ray radiation on a crystalline sample can be measured at given angles, revealing a pattern known as "d-spacings," that can be recorded on digital sensors.<sup>25</sup> The interaction between the incident rays and the sample "produces (a) constructive interface" governed by Bragg's Law:<sup>26</sup>

$$n\lambda=2d\sin\theta$$

$n$  = integer giving the order of reflection

$\lambda$  = the wavelength of the incident radiation in Angstroms

$d$  = the spacing between the planes in the atomic lattice

$\theta$  = the angle between the incident ray and the scattering planes

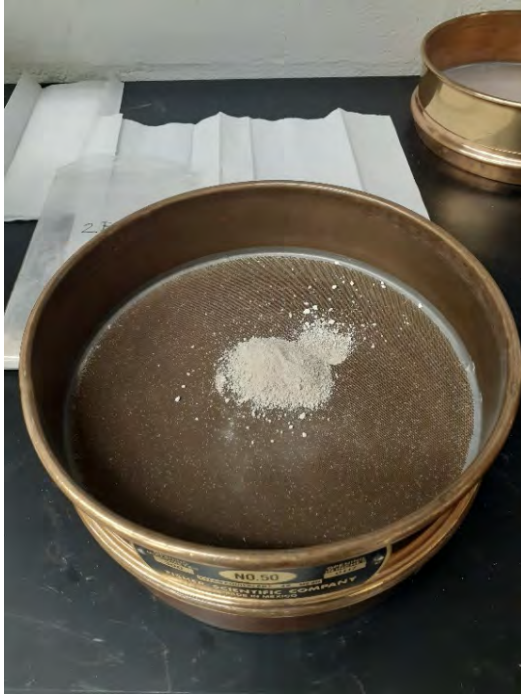
The "d-spacings" are unique to each material, and since each sample shows unknown "d-spacings," a computer software compares these with known samples for a tentative match upon analysis. The diffracted x-rays are then detected and recorded. A graph is usually generated, showing both planes of diffraction and intensity. The data comes from the "atomic and molecular arrangements explained by the physics of crystallography," and its interpretation is usually quick and straightforward.<sup>27</sup> The identification of phases in the samples is made by comparing libraries with known data by the software.<sup>28</sup>



*Fig. 5.33 & 5.34* – The computer and the MiniFlex 6G theta-2theta vertical goniometer benchtop powder diffraction system (machine) at the Penn's Laboratory for Research on the Structure of Matter (LRSM). Photos by Author.

The analysis was conducted between August 27<sup>th</sup> and the 31<sup>st</sup> at the University of Pennsylvania's Laboratory for Research on the Structure of Matter (LRSM) Material Science and Engineering (MSE) Departmental Laboratory, with the assistance of Courtney Magill. A Rigaku MiniFlex 6G theta-2theta vertical goniometer benchtop powder diffraction system (machine) was used for this test. The SmartLab Studio II software was used to interpret the preliminary data and to generate the graphics.

For this research, Samples 1A, 1B, 2A, 2B, 3A, 3B, 4 & 5 were ground to a fine powder with a mortar and pestle. The powder was then filtered through a No. 50 Sieve to obtain extremely refined powder samples suitable for the XRD analysis. The analysis requires a powder ranging from 1 to 5  $\mu\text{m}$  to avoid intensity fluctuations and spottiness and ensure "good particle participation in the diffraction process."<sup>29</sup> The powder was then placed on the small discs. 1 to 3 drops of denatured anhydrous ethanol were added to the powder sample to ensure cohesion and were left to dry for 5 minutes before the analysis.



*Fig. 5.35, 5.36 & 5.37* – Preparation of Samples for the XRD analysis included passing the powder through a No. 50 Sieve. The results were passed to a data software for interpretation. Photos by Author.

Results from the XRD powder analysis showed that the samples have high calcite/calcium carbonate, dolomite, and aragonite phases, specifically in Samples 1A, 2B, 3A, 3B, 4 & 5. Calcite/Calcium carbonate is attributed to the carbonation of the original

hydrated lime and lime component of Portland cement binders in the stucco. Dolomite -  $\text{CaMg}(\text{CO}_3)_2$  - is a common mineral usually found in a "fine-grain matrix of calcite" and can react with alkali solutions to form other compounds such as brucite and calcite.<sup>30</sup> Aragonite was found through XRD and can be attributed to marine sand and/or a local hydrated lime. Both aragonite and brucite found in the samples can also be attributed to seawater attack, mostly from rain and seawater splash sources. The Church is located on a windy and humid site in front of the coast. Even if the Portland cement stucco or concrete is not in contact with seawater directly, rain and seawater splash from the surrounding environment impacts the building. Other common compounds found were quartz and Brownmillerite (derivation from the Ferrite phase in the Gray Cement binder).

Sample 1B, 2B & 5 showed the presence of Pyrrhotite, and in Samples 1A & 4 of Pyrite, both are iron sulfides and deleterious compounds present in aggregates, possibly marine sand. Both pyrrhotite and pyrite are sulfide minerals that, in the presence of oxygen and an alkaline pore solution, can oxidize to produce ferric hydroxide and a range of sulfates. Sample 4 also showed Nitratine ( $\text{NaNO}_3$ ), while 3B showed the presence of Halite ( $\text{NaCl}$ ). Nitratine is a naturally occurring form of sodium nitrate and can be attributed to marine sand, seawater spray/rain, or a concrete accelerating or retarding admixture. At the same time, Halite is a sedimentary evaporate mineral, a form of sodium chloride, also attributed to seawater spray/rain. Potassium can be found in Samples 1A & 4, while phosphorus was only detected in Sample 4. Compounds such as Albite, Periclase, Alite, Larnite, and Microcline are also common compounds present in the samples. Albite ( $\text{NaAlSi}_3\text{O}_8$ ) is a low reactive/expansive plagioclase feldspar mineral attributed to the fine aggregates. Periclase ( $\text{MgO}$ ), Larnite ( $\text{Ca}_2\text{SiO}_4$ ), and Alite ( $\text{C}_3\text{S}$  in cement chemist notation) are common compounds found on cementitious materials. Microcline ( $\text{KAlSi}_3\text{O}_8$ ), found on Samples 2A, 2B & 5, is a potassium-rich alkali feldspar (potassium aluminum



silicate), Pyroxene - $XY(Si, Al)_2O_6$ , an inosilicate mineral found on Samples 1B & 2B, are both attributed to the fine aggregates. See Appendix 15 for a detailed list of phases per samples, data, and graphs.

#### 5.2.8 *Scanning Electron Microscopy - Energy Dispersive X-Ray Spectroscopy (SEM-EDS)*

The Scanning Electron Microscopy- Energy Dispersive X-Ray Spectroscopy (SEM-EDS) is one of the most versatile instruments available for the analysis of the elemental composition of materials, crystalline structure, changes in microstructure and external morphology (texture) or surface topography of materials. In this sense, the SEM is an essential analytical tool since "it allows for a visual examination of a material's physical microstructure while identifying its elemental composition at the same time."<sup>31</sup>

Usually, data from SEM is collected from a specific area of the Sample. The SEM can produce a 2D image from a magnification of 20X to approximately 30,000X, and a spatial resolution from 50 up to 100 nm.<sup>32</sup> The samples are "bombarded" with an electron beam (primary electrons), and a variety of signals such as secondary electrons, backscattered electrons (BSE), diffracted backscattered electrons (ESBD), photons, visible light, and heat are released from the atom's inner shells of the Sample, a process known as electron-sample interactions to observe the mentioned properties.<sup>33</sup> This process creates a pattern revealing a high-resolution image. This process is mostly based "on the interaction of the electrons with the textured surface of the material." If a sensor known as energy dispersive spectroscopy (EDS) is attached to the SEM, the wavelengths of generated x-rays can be read as "peaks," thus aiding in the generation of elemental composition maps on the selected area of the Sample. In this sense, the SEM-EDS has the "capability of isolating a point, line, or area and thus producing an elemental map of

the area."<sup>34</sup> Also, SEM analysis is 'non-destructive' since the X-rays generated by electron interactions do not produce any volume loss on the Sample.<sup>35</sup>

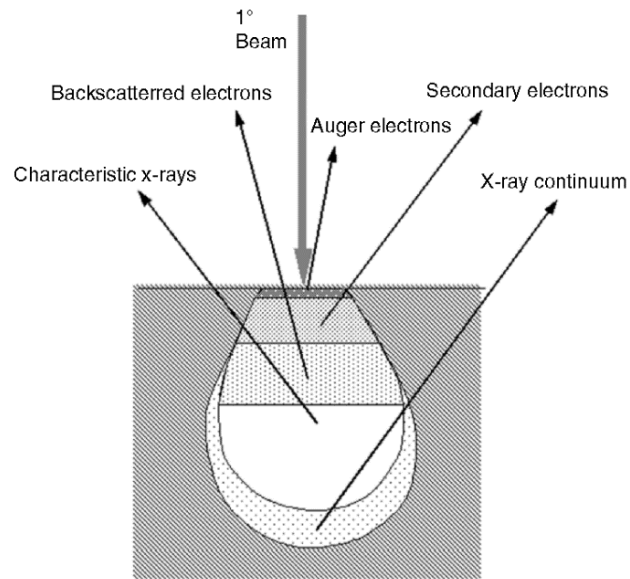


Fig. 5.38 – Several signals that are generated by the electron beam-specimen interaction in the SEM. Source: Zhou, Apkarian, Wang, and Joy, "Fundamentals of Scanning Electron Microscopy," 3.

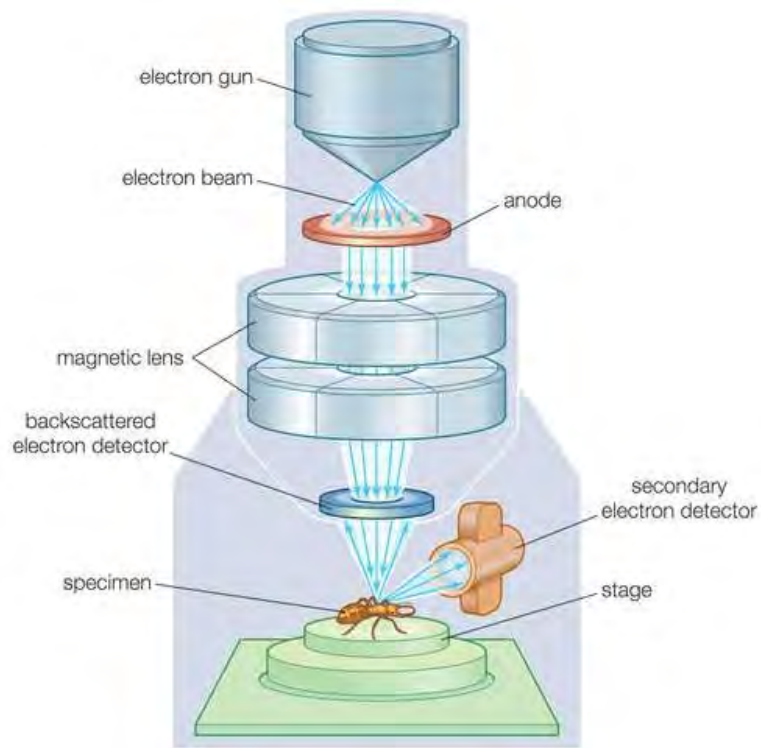


Fig. 5.39 – Parts of a Scanning Electron Microscope (SEM). Source: Encyclopedia Britannica, Inc. (2012).

For this research, the SEM-EDS testing was performed only on Samples 2A & 3A, specifically to map the elemental distribution (composition) of the sample constituents and any possible alteration components. Before selecting the final samples, they were observed and studied at various magnifications using a Leica MZ15 stereomicroscope. A 2" cross-section of stucco with metallic-ferrous aggregate/fillings from the dome and a 1" sample from 3A were cut with a small hammer and chisel. An FEI Quanta 600 FEG Mark II Environmental Scanning Electron Microscope was used with the assistance of Jamie Ford at the University of Pennsylvania's Laboratory for Research on the Structure of Matter (LRSM) Singh Center for Nanotechnology. A graphite pen was used to mark each cross-section in different areas to ensure each sample's identification (See figures 40, 41 & 42). Carbon tape was applied to the base of each sample to create a conductive seal between the specimen and stage. The settings used were a low vacuum, magnification 71x, high voltage of 15.0 kW, a spot size of 5.0, and WD of 14.9 mm. The samples were not coated. The area to be mapped was set at about 3mm (~0.12 inches) square.

The results on Sample 2A confirmed the metallic aggregate as Iron. The black 'asphaltic' coat contains carbon, sulfur, aluminum, and magnesium, while the paint coating is confirmed to be titanium-based. The cross-section is homogeneous, containing high concentrations of oxygen, calcium, and chlorine, the latter presumably from the maritime environment. The results on Sample 3A are also homogeneous, containing high concentrations of oxygen, carbon, and calcium as expected. The paint coating was confirmed to be titanium-based, and a high amount of silicon was found.

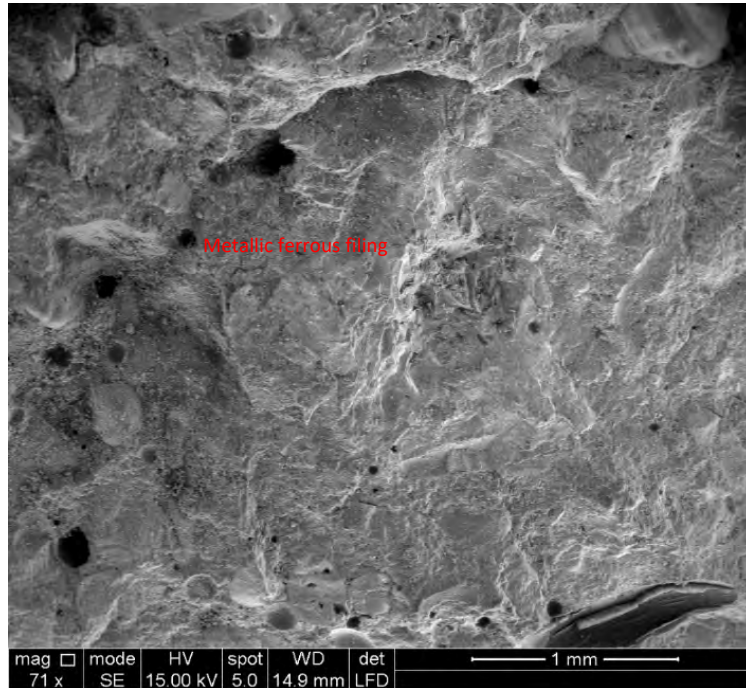
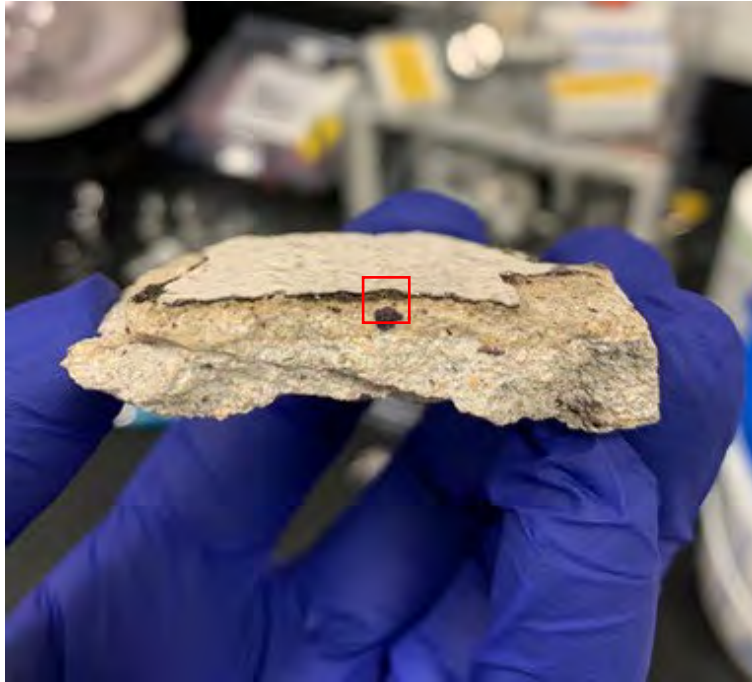


Fig. 5.40 – SEM micrograph on a metallic ferrous filing which confirmed to be Iron at .71x magnification using secondary electrons in Sample 2A-1. Photo by J. Ford.



Fig. 5.41 – Sample 2A-1 cross section with selected area before examination on the SEM on August 8<sup>th</sup>, 2020. Photo by Author.



*Fig. 5.42* – Sample 2A-1 cross section with selected area before examination on the SEM on September 8<sup>th</sup>, 2020. Photo by J. Ford.



*Fig. 5.43* – Sample 3A cross section with selected area before examination on the SEM on August 8<sup>th</sup>, 2020. Photo by J. Ford.

### 5.3 General Conclusions

The investigation confirmed three different stucco formulations and two methods of application at the Del Carmen Church. All stuccos are composed of local calcareous biogenic marine sand, hydrated lime, and gray Portland cement.

*Table 5.3 – Composition of Stucco in Specs vs. Testing Results*

Klumb's Construction Specifications for Del Carmen Church	Instrumental Analysis - Results
White Portland Cement	Grey Portland Cement (Preliminary confirmation of Ferrite/Brownmillerite phases)
White silica sand	Local calcareous biogenic marine sand
Hydrated lime	Hydrated lime
	Metallic ferrous aggregate – Iron filings (only in Dome Stucco)

The dome stucco upper layer had the addition of ferrous particulate (filings), which were not indicated in the construction specifications but were used by Klumb on other projects in mortar and stucco mixes to decrease water penetration by reducing porosity and permeability through ferrous particulate redox expansion. The addition of iron filings did not appear to change the color of the dome stucco significantly.

The difference in microstructure, specifically porosity, identified the two application methods of troweled and sprayed stucco. The shotcrete/sprayed stucco showed poor compaction and numerous irregularly shaped voids, and greater porosity than the troweled Stucco. The difference in porosity showed the difference in the application methods since 'Dry method Shotcrete' was probably used. A dry mix will reduce slump on a vertical and tilted wall and overhead surfaces. In a dry-mix application method, the amount of water in the mix relies heavily on the nozzleman's workmanship.<sup>36</sup> Porosity also influences the strength and performance of the material.<sup>37</sup> Both the onsite investigation and cross-sectional analysis confirmed that the poured-in-place concrete substrates were not

mechanically prepared to apply the stuccos. The shotcrete/sprayed stucco also showed poorer bonding between the Stucco and the concrete substrate. These findings complement the Conditions Assessment on Chapter 4 since, as Poole & Sims mention regarding Sprayed Stucco, "localized lack of bond and the formation of large voids are common problems."<sup>38</sup>

Fine micro-cracks and poor adhesion issues as seen in the Polarized Reflected Microscopy can allow the penetration of moisture and salts and causing a relatively higher impermeable stucco, trapping moisture on the concrete substrates, and higher loss of adhesion.<sup>39</sup>

The investigation showed some ongoing deterioration issues on the stucco and concrete. For example, 6 out of 8 samples showed full carbonation on both the stucco and concrete substrate. The samples showed the presence of deleterious salts such as chlorides and nitrates attributed to environmental contaminants. The presence of Pyrrhotite and Pyrite phases were also found and attributed to internal sulfate attack. Pyrrhotite and Pyrite are present in aggregate, possibly marine sand. Both pyrrhotite and pyrite are sulfide minerals that, in the presence of oxygen and the alkaline pore solution, can oxidize to produce ferric hydroxide and a range of sulfates.

Aragonite was also found through XRD and attributed to marine sand and/or a local hydrated lime. Both aragonite and brucite found in the samples can be attributed to seawater attack. Even if the Portland cement stucco or concrete is not in direct contact with seawater, it can be affected by rain and seawater splash.

Lastly, both onsite and petrographic analysis confirmed the application of between one (1) to two (2) layers of paint on the concrete and stucco exteriors of the Church. The SEM-EDS confirmed Titanium-based paint. Both archival and photographic evidence

shows that Klumb had initially specified that the exteriors were to be painted but later changed his mind between 1961 and 1962 and indicated they were to be left unpainted.

## Endnotes

---

<sup>1</sup> Jeanne Marie Teutonico, *A Laboratory Manual for Architectural Conservators* (Rome: ICCROM-International Centre for the Study of the Preservation and the Restoration of Cultural Property, 1988), vii.

<sup>2</sup> Other common instrumental analyses used in the industry include Fourier transform infrared microscopy, transmission electron microscopes (TEM), cryo-SEM, microstructural for predicting concrete properties, and x-ray microscopy.

<sup>3</sup> Some samples such as 1A, 2A and 4 were further divided and were used in different instrumental analyses such as PLM, and powder for the X-Ray diffraction and Salt testing. From the original 1A sample a total of seven (7) samples were extracted (1A-1, 1A-2, 1A-3, 1A-4, 1A-5, 1A-6, 1A-7). From the original 2A sample a total of seven (7) samples were extracted (2A-1, 2A-2, 2A-3, 2A-4, 2A-5, 2A-6 & 2A-7). From Sample 4, a total of three (3) samples were extracted (4-1, 4-2 & 4-3).

<sup>4</sup> Alan B. Poole and Ian Sims, *Concrete Petrography: A handbook of investigative techniques*, 2<sup>nd</sup> ed. (Boca Raton, FL: CRC Press-Taylor & Francis Group, LLC, 2016), 13.

<sup>5</sup> Udo Ludwig, "Durability of Cement Mortars and Concretes," ASTM STP 691 - *Durability of Building Materials and Components*, P. J. Sereda and G. G. Litvan, Eds., (Detroit, MI: American Society for Testing and Materials, 1980), 270.

<sup>6</sup> David Odgers, ed., *Practical Building Conservation: Concrete*, (London, UK: English Heritage, 2012), 86.

<sup>7</sup> *Ibid.*, 410 & 411.

<sup>8</sup> *Ibid.*, 122.

<sup>9</sup> *Ibid.*, 97.

<sup>10</sup> Sarah Jane Stratte, "An Evaluation of Historic Cement Stucco Using Conditions Assessment Methodology and Digital Visualization Tools, Grand Teton National Park, USA" (Master's thesis, University of Pennsylvania, 2018), 115.

<sup>11</sup> This test was outlined in an unpublished book by Dr. Jose Delgado Rodrigues, Principal Research Officer of National Laboratory for Civil Engineering in Portugal. The source was provided by Dr. George Wheeler. A similar procedure was outlined by Dr. Delgado in A. Ferreira Pinto & J. Delgado Rodrigues, "Assessment of the durability of water repellents by means of exposure tests," in V. Fassina, ed., *Proceedings of the 9th International Congress on Deterioration and Conservation of Stone*, Venice, 19–24 June, 2000, Vol. 2 (Amsterdam: Elsevier, 2000), 273–285.

<sup>12</sup> A standard distance between the two (2) drops in both the samples and glass plates was selected as  $\frac{1}{2}$ ", except for Sample 1B (which used a distance of  $\frac{1}{4}$ ") and Sample 5 which only needed 1 drop.

<sup>13</sup> Delgado mentions that the "shorter the absorption time is, the higher is the prevalence of absorption over evaporation." *Ibid.*

<sup>14</sup> ACI 506.4R – Evaluation of Shotcrete, (Detroit, MI: American Concrete Institute, 1994), 9.

<sup>15</sup> For a complete history and timeline of Petrography applied to Concrete since the 19<sup>th</sup> Century through the 21<sup>st</sup> Century see Dipayan Jana, "Concrete Petrography-Past, Present, and Future," Proceedings of the 10<sup>th</sup> Euroseminar on Microscopy Applied to Building Materials (EMABM), (Pasiley, Scotland: 21-24 June 2005).

<sup>16</sup> Jeremy P. Ingham, *Geomaterials Under the microscope: A Colorful Guide* (Boca Raton, FL: CRC Press-Taylor & Francis Group, LLC/Manson Publishing, 2011), 152.

<sup>17</sup> Jeremy C. Wells, "History and Characterization of Mortars in Spanish New World Fortifications: A Case Study on El Castillo de San Cristobal, San Juan, Puerto Rico" (Master's thesis, University of Pennsylvania, 2004), 61.

<sup>18</sup> Poole & Sims, *Concrete Petrography...* 5.

<sup>19</sup> After consultation with Concrete Petrographer Karla Salashour a blue dye epoxy resin was selected for mounting the stucco specimens, since it helps to differentiate between variations in permeability in a material. Poole & Sims also discusses this issue. See Poole & Sims, *Concrete Petrography...* 82.

<sup>20</sup> This change may on the Portland cement may be for cost reasons. Since the archival records suggested that the project run off of money and the Church's design was completely changed between December 1960 and



---

February 1961. Because of the lack of archival records from the construction phase after May 1961, no specific information was found related to the change on overall construction materials.

<sup>21</sup> For a specific discussion regarding ettringite in hardened concrete, see Poole & Sims, *Concrete Petrography...* 305-307.

<sup>22</sup> Lauren Vollono Drapala, "Rediscovering an American Master: An Examination and Analysis of the Decorative Plaster Ceiling of Robert Winthrop Chanler's Whitney Studio, New York" (Master's thesis, University of Pennsylvania, 2010), 159.

<sup>23</sup> Wells, "History and Characterization..." 64.

<sup>24</sup> Barbara L. Dutrow and Christine M. Clark, "X-ray Powder Diffraction (XRD)," *Geochemical Instrumentation and Analysis*, Science Education Resource Center (SERC)-Carleton College, accessed on Feb 3rd, 2020, [https://serc.carleton.edu/research\\_education/geochemsheets/techniques/XRD.html](https://serc.carleton.edu/research_education/geochemsheets/techniques/XRD.html)

<sup>25</sup> Vollono Drapala, "Rediscovering an American Master..." 159.

<sup>26</sup> Dutrow & Clark mentions that the Bragg's Law "...relates the wavelength of electromagnetic radiation to the diffraction angle and the lattice spacing in a crystalline sample." See Dutrow & Clark, "X-ray Powder Diffraction (XRD)."

<sup>27</sup> Andrei A. Bunaciu, Elena Gabriela Udristioiu & Hassan Y. Aboul-Enein, "X-Ray Diffraction: Instrumentation and Applications," *Critical Reviews in Analytical Chemistry* 45, No. 4 (April 2015): 298.

<sup>28</sup> Poole & Sims mentions that the major source of XRD data related to materials is the Powder Diffraction File (PDF) developed by the ASTM and updated by the International Centre for Diffraction Data. Poole & Sims, *Concrete Petrography...* 33.

<sup>29</sup> Ibid. 291

<sup>30</sup> Poole & Sims, *Concrete Petrography...* 554.

<sup>31</sup> Vollono Drapala, "Rediscovering an American Master..." 153.

<sup>32</sup> Susan Swapp, "Scanning Electron Microscopy (SEM)," *Geochemical Instrumentation and Analysis*, Science Education Resource Center (SERC)-Carleton College, accessed on Feb 3rd, 2020, [https://serc.carleton.edu/research\\_education/geochemsheets/techniques/SEM.html](https://serc.carleton.edu/research_education/geochemsheets/techniques/SEM.html).

<sup>33</sup> Swapp mentions that secondary electrons produce the SEM images, diffracted backscattered electrons (EBSD) are used to determine crystal structures and orientations of minerals; and photons or characteristic X-rays are used for elemental analysis and continuum X-rays. Ibid.

<sup>34</sup> Julianne Wiesner-Chianese, "Modern in the Mountains: An Analysis of the Structural and Decorative Concrete at Jackson Lake Lodge in Grand Teton National Park, WY" (Master's thesis, University of Pennsylvania, 2015), 134.

<sup>35</sup> Swapp, "Scanning Electron Microscopy (SEM)."

<sup>36</sup> Poole & Sims mentions that "Excess voidage...is largely restricted to dryer concrete mixes that do not flow easily. The extreme condition is where insufficient water is used so that the cement and water are not fully dispersed during mixing giving rise to rich layers of sticky cement surrounding aggregates which are almost impossible to compact." Poole & Sims, *Concrete Petrography...* 354.

<sup>37</sup> N. Banthia, "Sprayed concrete (Shotcrete)," in Sidney Mindess, *Developments in the Formulation and Reinforcement of Concrete*, 1st ed. (Duxford, UK: Woodhead Publishing, 2008), 101.

<sup>38</sup> Poole & Sims, *Concrete Petrography...* 663.

<sup>39</sup> Ibid.

## CHAPTER 6

### Recommendations & Conclusions

"Few materials have been so little appreciated and so badly maintained and treated as...artificial cement stuccos."

– John Ashurst in *Mortars, Plasters, and Renders in Conservation* (1983), p. 81.

"...the indifference towards care and maintenance... Interior and exterior maintenance are rarely included in budgets and, if included, it is in an amount sufficient to scrub the floor, not to keep it clean." -Revista *Urbe* Núm. 33, Vol. 8 (febrero- marzo 1969), p. 60, translated by Jorge Rigau.<sup>1</sup>

The exterior appearance of the Del Carmen Church is determined by the color and texture of its Stucco skin. The irregular and soft, and rough surfaces of the stucco created by the different application methods: a smooth troweled stucco on the elevation walls and the rough gunite stucco under the dome walls, help define the buildings' massing and affect how the tropical light interacts with the surface. These original surface effects, which are an integral part of the building's construction, have been greatly compromised by the later applied paint, biological soiling, and cracks, which rob the building of its full aesthetic effect.

While treatment analyses were not a part of this thesis, the findings confirm that the exterior stucco was original to the building to unify the external appearance of the different substrate materials and that the unpainted surface was the 'finished' appearance Klumb desired as he specified that "the natural textured cement finishes were to be left to weather." Exterior photos from the 1960s showed the exterior cement stucco stained and mottled by 1964. Today, the exterior is further compromised by the peeling and discolored paint and bio-growth and may retain moisture adding to concrete and stucco deterioration.

This thesis recommends a testing program to determine the best treatment options for removing the currently painted coatings and possible soiling beneath without damaging the cement stuccoes and returning the building to its original exposed stucco surfaces.

Some consideration and discussion with stakeholders, including the congregation, will be necessary for the final desired appearance of the exterior surfaces. Recommendations for paint removal and secondary cleaning of the exposed surfaces include low-impact abrasive methods such as superheated low-pressure steam or low-pressure microabrasives. Further recommendations include the use of hydrophobization treatments such as a silane or siloxane penetrant to repel water, discourage salt penetration, and prevent staining and biofouling and corrosion inhibitors. Water repellent and corrosion inhibitor treatments will also protect the vulnerable concrete substrate and its reinforcement from the harsh tropical maritime environment of Puerto Rico. Lastly, the recommendation for further testing and specific repairs on localized areas are discussed. Thus, these recommendations do not intend to be firm and final; they aim to serve as guidelines for future investigations and prospective treatment considerations.

One of the current challenges when specifying historic concrete treatments is using methods from the concrete repair industry only. As a developing field, concrete conservation uses similar technologies but taking into account conservation principles, including minimal intervention for maximum effect. For this research, the approaches of the concrete conservation field are followed.<sup>2</sup>

### **6.1 Considerations before choosing Conservation Treatments**

There are several considerations for conservation treatments on a historic building. First, any treatment decisions (cleaning, repair, coatings) must be part of a prior decision-making process involving all stakeholders. Second, since the conservation issues on a historic building come from such varied factors (environment, site, materials, maintenance, cultural practices, etc.), there is no single guided process for any treatment. These must be designed considering the particularities of the building, available resources, needs of the stakeholders, and maintenance regimes, among other considerations. Thirdly, any

suitable treatment must be accompanied by a full understanding of the concrete and its pathologies. This must include an in-depth knowledge of what is to be cleaned, removed (paint), repaired, etc. Fourth, an evaluation of costs, equipment needed, available expertise (personnel), the setting, in-depth information of products and manufacturers (including case studies in which the treatment has been used) must be done before selecting a suitable cleaning treatment(s) for testing and selection. This information will be vital for evaluating the pros and cons of each treatment.

Fifth, before selecting a final conservation treatment, a testing program must be undertaken onsite starting from the least invasive method since it will help refine the procedures and materials needed to ensure a compatible treatment. The products used for a testing program must be from the same manufacturer to ensure compatibility within the products and the materials and quality control. The same equipment and procedures as proposed for large-scale work must be followed.<sup>3</sup> The testing program should be carried out on representative inaccessible/hidden spaces (small areas). Instrumental analyses of these treatments by an independent Laboratory is necessary to understand how any treatment affects the material at a microscopic level. Tests, as outlined in ASTM D4262 and D4263, are usually considered for treatments on masonry/concrete buildings.

An evaluation of these tests must be done once the masonry is completely dry for weeks or even months. One full year of weathering is preferable. Photo documentation of before and after treatments is required. The analysis will serve to determine the long-term effect of the treatments on the material(s). Furthermore, the successfully tested areas should serve as treatment standard reference for the large work on the building.<sup>4</sup> The design of a suitable testing program must be done by an experienced Architectural Conservator and should involve all the personnel performing the exterior restoration for

the building. Approval from a Preservation/Conservation Architect is necessary before undertaking any large-scale treatments on the building.

Lastly, when selecting a suitable treatment, the least harmful treatment is expected for the material(s), with the application starting from bottom to top of the building.<sup>5</sup> Environmental considerations such as tropical high temperatures and high relative humidity, in which concrete is prone to attack, must be considered before applying any treatments while undertaking any mitigation efforts.<sup>6</sup> Constant supervision and monitoring while the treatments are applied are critical for a successful project. This same process must be followed to apply cleaning treatments, coating systems such as hydrophobic penetrants, and specific mechanical repairs.

After an analysis, the following steps must be taken to ensure a proper restoration of the exterior surfaces of the Del Carmen Church:

1. Correction of the drainage and moisture issues affecting the roof slabs and exterior walls.
2. Additional testing and assessments.
3. The removal of biological growth. Magnesium fluorosilicate ( $F_6MgSi$ ) or copper naphthenate ( $CuC_nH_{2n-z}O_4$ ) are recommended for this task. Common herbicides must be avoided since they possess a significant amount of salts, which can be absorbed into the exterior stucco and concrete surfaces and cause damage.
4. The removal of biofouling stains and bird droppings. The removal of bird droppings from the exterior surfaces must be done with a non-metallic brush and/or low-pressure washer with an acidic cleaner.<sup>7</sup>
5. The removal of paint layers from the stucco and concrete exteriors.

6. Repairs on selected areas of the building (cracks, stucco debonding/delamination, corrosion, material replacement).
7. Application of coating systems over the exterior surfaces includes using silane/siloxane penetrants for water-repelling and corrosion inhibitors.
8. Re-installation of bird nets to prevent access of pigeons to the interior of the Church and hidden areas of the dome, thus preventing droppings on the exterior stuccoed surfaces.

## **6.2 Cleaning**

The cleaning of masonry materials is often undertaken for several reasons, including aesthetic considerations, like the improvement or restoration of the original appearance of a building, the removal of deleterious agents, and the prevention of future deterioration issues.<sup>8</sup> Still, the cleaning of masonry materials, including Portland cement stucco and Concrete, presents several issues. As masonry materials are vulnerable, improper cleaning treatment can be damaging, and selected treatment procedures and materials are sometimes incompatible with the original materials.<sup>9</sup> Furthermore, improper/incompatible cleaning treatments can cause further deterioration issues on the material. In the case of stucco work, the threat of inappropriate treatments and applications increases as it is a vulnerable material, historically seen as sacrificial and protective without relative aesthetic importance with some exceptions.

Considering the current characteristics and pathologies of the exterior stuccoed surfaces on the Del Carmen Church, a superheated low-pressure water wash and steam are recommended for paint removal from the exterior stucco. Hot low-pressure water and low-pressure water wash with non-ionic detergent are recommended for the surfaces' secondary cleaning. Other cleaning alternatives such as micro-abrasive methods should be considered if the cleaning needs to be done dry to reduce water intrusion into the stucco or concrete. Chemical methods such as traditional alkaline paint strippers usually leave

behind soluble salts on the material, which is not ideal for a porous material that has been already subject to salt penetrations due to its exposure to the tropical coastal environment.<sup>10</sup> The recommended cleaning treatments must be tested following a strict testing program. Variations for applying these cleaning treatments must be considered for each stucco application (i.e., shotcrete/gunite being more permeable and porous).

Paint removal recommendations include superheated low-pressure water wash (35 to 75 psi) and superheated water steam. The use of superheated low-pressure water allows high-temperature water (120-150 °C/248-302 °F) with variable and controlled pressures and a typical spray angle of 35-40°.<sup>11</sup> Steam is an effective treatment for removing synthetic paint films and other materials such as the applied bitumen waterproof layers at the dome.<sup>12</sup> The use of both steam and superheated pressure-washer helps to soften the paint layers. The paint layers must then be carefully removed mechanically.<sup>13</sup> Proper care is needed to retain the original stucco. When addressing paint residues, other tested and approved methods shall be used, but the treatments should never remove stucco layers. As a last final resource, when the paint has penetrated the stucco and paint residue removal is not possible without damaging the material, the stucco can be tinted in place or removed and replaced with a new patch. This option should be discussed with all stakeholders, and specific materials need to be tested to ensure compatibility (paint color or stucco mix materials and proportions). Skilled contractors must do all work. Onsite testing of the superheated washer pressure using low to medium pressures should be done before their application over the whole building.

Finally, if the recommended treatments do not provide the expected results, other options such as the *Dumond Smart Strip*<sup>™</sup> Pro low-VOC, water-based, bio-degradable chemical stripping from Dumond Chemical Inc. can be tested on the stucco. This chemical stripping has been used successfully to remove thinly coated surfaces in similar projects

such as the Miami Marine Stadium in Florida.<sup>14</sup> It is essential to consider the different characteristics of the exterior stuccoes. For example, a more gentle treatment should be tested and probably used for the sprayed stucco because of its porosity and bonding issues with the poured-in-place concrete substrate compared to the hand-troweled stucco in other parts of the building.

### **6.3 Coating Protection Systems - Penetrants**

The concrete repair industry often uses protective coating systems to protect concrete and extend the service length of the material in non-historic buildings. These can be cataloged as film formers (sealants) and penetrants.<sup>15</sup> Considering the characteristics of the exterior surfaces of the Del Carmen Church and its environmental context, a hydrophobic impregnation penetrant coating protective system is recommended as a treatment before a careful testing program.<sup>16</sup> A hydrophobic penetrant is characterized by being colorless, having water vapor transmission or "breathability," limit and control the ingress of water, carbon dioxide, and aggressive chemicals (salts) that enters the concrete, prevent further deterioration, enhance the appearance of concrete/stucco and does not affect the coefficient of friction of the material.<sup>17</sup> A penetrant alters the surface tension properties of a masonry substrate allowing water vapor to pass freely, thus providing hydrophobic and water vapor transmission characteristics.<sup>18</sup> Penetrants should not be confused with consolidants; they are protective and require periodic reapplication. They are irreversible but are more suitable for conservation if the system has good mechanical performance and compatibility with the concrete.

Hydrophobic penetrants enter the pore structure of concrete substrates and deposit their water-repellent components on the pores or pore walls. The amount of penetration on a concrete substrate depends on its porosity, but the tests show that usually, the depth of penetration is no greater than 0.1 inches.<sup>19</sup> Penetrants are often



water-based and formulated from modified organosilicon compounds, including siloxanes, silanes, alkoxy silanes, or metallic stearates.<sup>20</sup> The product is composed of both an organofunctional group which provides hydrophobic properties eliminating the capillary suction properties of pores, and a silicon functional group that controls the bonding with the substrate.<sup>21</sup> Siloxane (Si-O-Si) penetrants can form quick chemical bonds with siliceous and alumina containing materials because silicon molecules react with organic and inorganic materials and usually pass through three (3) main reactions when applied to concrete substrates: hydrolysis, condensation, and bonding.<sup>22</sup> Silane (SiH<sub>4</sub>) penetrants (monomeric alkyltrialkoxysilanes) are more effective than siloxanes because they possess three (3) silicon (alkoxy portion) functional groups; they can penetrate the concrete substrate because of its molecular size and do not require dilution with alcohol.<sup>23</sup> Still, silanes are more volatile than siloxanes, and an application of a 100% silane solution is recommended.

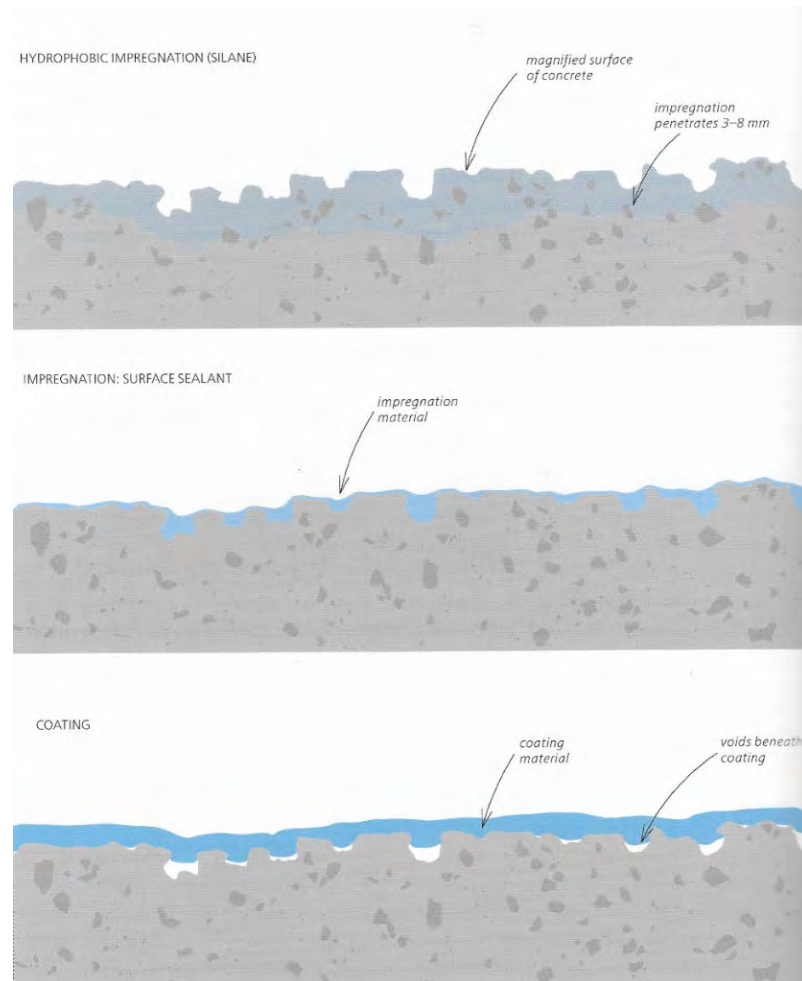


Fig. 6.1 – Differences in the application of penetrants, film forming-sealants and coatings over concrete and Portland cement stuccoes. Source: David Odgers, ed., *Practical Building Conservation: Concrete*, (London, UK: English Heritage, 2012), 68.

Application methods for penetrants include low-pressure spraying (15 to 30 psi), rolling, brushing, or flood coating. Overapplication of penetrant should be avoided. Depending on the product, bonding in calcareous, including cementitious surfaces, requires a surface pre-treatment with ethyl silicate.<sup>24</sup> Specific considerations for choosing penetrants as a coating treatment include differences between silicones, silanes, and siloxanes in terms of alkyl groups, number and type of silicon, functional groups, and polymerization processes. This is important to ensure the best compatible product with the treated and repaired concrete/stucco substrate. Other considerations include following the manufacturer's direction for the product and the need for onsite and laboratory testing

before a large-scale application of penetrant treatments to ensure the system does not change the color or harm the stucco or concrete substrate once applied using the right surface preparation, weather, and temperatures. Common tests to evaluate the effectivity of hydrophobic penetrants are ASTM D1653 and modified ASTM E97.

Some precautions in the application of hydrophobic penetrants include:

1. In specific conditions, penetrants may be subject to hydrolysis and thus breaking their bonds.
2. Alkaline conditions on a substrate can cause catalyzed depolymerization of a penetrant.
3. Penetrants can sometimes leave a white residue on a masonry substrate because catalyst compounds react prematurely to excessive moisture on the material.
4. Penetrants are not irreversible and may leave material residues on the porous structure for more than 30 years.<sup>25</sup>
5. Penetrants do not work on damp or ponded surfaces, and a bond will not be formed with the masonry substrate.
6. Penetrants provide little or no protection against carbonation.<sup>26</sup>
7. If the substrate has high porosity, it can affect the penetrant's performance, as outlined by ACI 512-2R.
8. Silane needs more care during its application since it can evaporate under hot or windy environments, decreasing its effectiveness once applied.<sup>27</sup>

#### **6.4 Corrosion Inhibitors/Cathodic Protection Systems**

Since the Del Carmen Church shows signs of rebar corrosion in selected areas, the application of corrosion inhibitors over the exterior surfaces is recommended. Corrosion inhibitors are usually used as preventive treatments for concrete repairs. They can be amino alcohol-based and tend to reduce rebar corrosion by penetrating the

concrete and forming a passive monomolecular layer around the steel, thus preventing chloride attack and inhibiting the reaction with oxygen and water that allows the corrosion process.<sup>28</sup> Inhibitors can be made of several inorganic, organic, and volatile materials.<sup>29</sup> There are two types of corrosion inhibitors: as an additive to concrete repair mixtures or by diffusion and/or capillary action once applied to concrete structures.<sup>30</sup> Migratory corrosion inhibitors (like penetrants) can be used directly in concrete substrates. Corrosion inhibitors can also be applied to steel rebars under repair or as a vapor phase inhibitor, introduced in pellet holes through the concrete substrate.<sup>31</sup> Corrosion inhibitors work in heavily salt-contaminated concrete substrates, and they are often invisible when applied to substrates. Still, depending on the Concrete composition and other factors, the final visual effect can vary.<sup>32</sup> Their application over concrete and stucco surfaces is recommended following repairs, and an evaluation of penetration effectivity on the Concrete is required. If both hydrophobic penetrants and corrosion inhibitors will be used, compatibility between these two treatments should be examined extensively.

Finally, using a combination of passive (sacrificial anode) and active cathodic protection systems is recommended as a long-term preventive conservation treatment considering the aggressive environment where the Church sits. The passive system is usually installed embedded on the fabric or adjacent to concrete repairs to the internal steelwork and linked to electric cables/wires with a supervised electric application. Since this, a very invasive treatment, careful planning, and testing process need to be undertaken before its full application over the building. Usually, cathodic protection systems can endure up to 50 years, compared to repairs, which usually last between 10 to 30 years.

## **6.5 Further Testing**

Before repairs on the exterior surfaces, a series of testing should complement this thesis's findings. Recommendations for further testing includes an adhesive bond strength of the stuccoed surfaces to determine the full extent of detachment and the viability of the use of cementitious grouts for reattachment, as well as the removal and replacement of original stucco with custom formulations. An analysis of the mix proportions of the stucco and concrete surfaces must be done to ensure full compatibility between the concrete repairs and the existing material.

## **6.6 Mechanical Repairs**

Repairs on a concrete conservation project seek to minimize its impact on the material fabric, especially on concrete finishes, since they are more vulnerable. A proper repair on historic concrete must address current deterioration issues, reduce the rate of deterioration, and prevent further deterioration issues.<sup>33</sup> In a repair process, a careful appraisal of the degrees of intervention should be discussed with all stakeholders before selecting the final project. For the Del Carmen Church, mechanical repair recommendations include addressing cracks, stucco debonding, rebar corrosion on selected areas, and patch repairs. The compatibility of materials and techniques and onsite and laboratory testing and recording and monitoring is critical for a successful repair campaign. Cementitious grouts are often used for stucco repair and should be considered as a first option. Stucco replacement is recommended only on an area where 40% to 50% shows loss of bond and should match the original stucco finish as close as possible in composition, color, texture, and mechanical properties.<sup>34</sup> Shotcrete/gunite substrates and finishes are often removed and replaced. There are no compatibility issues if a dry-mix stucco is replaced with wet-mix stucco; however, considering conservation principles, texture, color, and other aesthetic considerations must be followed.<sup>35</sup> Lastly, crack fillers

are recommended to be considered for testing on several cracks around the Church, especially on the pre-cast concrete louver. Ashurst suggests the following sequence of repairs, which can be followed as part of the overall project:<sup>36</sup>

1. Repair of surface crack fillings
2. Repair of surface texture fillings
3. Repair of localized and superficial damage
4. Larger scale replacement
5. Grouting of detached areas

## **6.7 Conclusions**

"With the transformation of a building to a monument of cultural heritage, its fabric, its materiality and its appearance also become part of the authenticity that has to be protected... the original appearance must be understood in a dialectic way as the aesthetic result of artistic and functional intentions: both the result of materials and techniques applied to the architectural surfaces. The materials and techniques themselves play their autonomous aesthetic role; their aesthetic appearance consists not only of the technology intentionally applied to architectural surfaces but also of the intrinsic, natural qualities of the materials and techniques." - Ivo Hammer <sup>37</sup>

Much has been written about Henry Klumb's work from a historical and regional perspective; still, a fuller understanding of his building materials and methods is necessary. Moreover, the use of concrete technologies and concrete finishes in modern architecture in the Caribbean region is still an understudied topic. This research aims to support the restoration of the Del Carmen Church while furthering the knowledge on both mid-twentieth century concrete technologies in Puerto Rico and Klumb's legacy.

The period of growth and prosperity that endured from the 1950s through the 1960s in Puerto Rico created the building, and that is still used today. For a majority of Puerto Ricans, it is challenging to recognize and see buildings which they had demolished,

rehabilitated, repaired, and transformed dramatically over the last seven decades as "historic" and as their "heritage." In this sense, much of the integrity of modern architecture in Puerto Rico has been lost over the last decades. In this sense, the Parroquia Nuestra Señora del Carmen in Cataño is an exceptional case.

As the original intent of any historic structure, and especially when architect-designed, is one of the critical issues that inform the conservation of modern architecture, given the architectural significance of Del Carmen Church, this thesis aims to rescue Klumb's original intent for the exterior. This research addresses this issue while considering how that intent can be made visible again. As the proper scientific studies of historic fabric and a building's materiality are often neglected in modern architecture, this case study shows the importance of field and testing investigations. The conservation issues of the Parroquia Nuestra Señora del Carmen reveal the current and growing need to reconcile the technical necessities of preserving cement stucco and exposed concrete, especially in Puerto Rico's tropical environment, with its historical design intent and current realities. To do anything less would be to misinterpret the many faces of modernity in Puerto Rico and the mid-twentieth century.

## Endnotes

---

<sup>1</sup> Jorge Rigau, "Architecture of the 1960s in Puerto Rico, 1958-1972", National Register of Historic Places Multiple Property Documentation Form (San Juan, PR: Jorge Rigau Architects PSC, July 3rd, 2019), 90.

<sup>2</sup> Susan Macdonald and Ana Paula Arato Gonçalves, *Conservation Principles for Concrete of Cultural Significance*, (Los Angeles: Getty Conservation Institute, 2020), 5.

<sup>3</sup> Robert C. Mack & Anne Grimmer, "Assessing Cleaning and Water-Repellent Treatments for Historic Masonry Buildings," *Preservation Briefs 1* (Washington, DC: National Park Service, Heritage Preservation Services, 2000), 11.

<sup>4</sup> Anne Grimmer, *Keeping it clean: removing exterior dirt, paint, stains, and graffiti from historic masonry buildings*, (Washington, DC: National Park Service, Technical Preservation Services, 1988), 6.

<sup>5</sup> Mack & Grimmer, "Assessing Cleaning and Water-Repellent...", 4.

<sup>6</sup> *Ibid.*, 12.

<sup>7</sup> Hydrofluoric acid does not react violently with cementitious materials and does not leave salt residues on masonry. David Hadden, "Cleaning Restoration of the Baha'I House of Worship," *Concrete International* 14, No. 9 (September 1992): 46.

- 
- <sup>8</sup> Thomas H. Rudder, "The Cleaning of Masonry Buildings," *Concrete Repair Bulletin* (January/February 2005): 18.
- <sup>9</sup> Norman Weiss, *Draft - Exterior Cleaning of Historic Masonry Buildings*, (Washington, DC: U.S. Department of the Interior, National Park Service, 1985), 4.
- <sup>10</sup> Alison Henry and John Stewart, *Practical Building Conservation: Mortars, Renders and Plasters* (Historic England, 2011), 468.
- <sup>11</sup> David Odgers, ed., *Practical Building Conservation: Concrete*, (London, UK: English Heritage, 2012), 194.
- <sup>12</sup> John Ashurst, *Mortars, Plasters and Renders in Conservation*, (RIBA Publications Ltd, 1983), 83.
- <sup>13</sup> Proper management of paint layer residues needs to be included on the project's scope.
- <sup>14</sup> RLA Conservation, Inc., John Fidler Preservation Technology, Inc. & Lynch & Ferraro Engineering, Inc. "Final Report – MMS-CONSOL: Concrete Solutions: A standard-setting project for graffiti management, surface cleaning and patch repair of historic concrete, utilizing the Miami Marine Stadium as a test site," (Los Angeles: Getty Conservation Institute, 2016), 72 & 81.
- <sup>15</sup> Edward McGettigan, "Factors Affecting the Selection of Water-Repellent Treatments," *APT Bulletin: The Journal of Preservation Technology* 26, No. 4 (1995): 22-24.
- <sup>16</sup> A film forming system was discarded due to its sensitivity to ultraviolet (UV) light and poor breathability. See *Ibid.*, 25-26.
- <sup>17</sup> ACI 515.2R-13 – Guide for Selecting Protective Treatments for Concrete, (Farmington Hills, MI: American Concrete Institute, 2013), 21 & Shaun A. Hurley, "Coatings for Concrete," in Michael G. Graham, ed. *Concrete Repair: A Practical guide*, (New York, NY: Taylor & Francis Group, 2011), 280.
- <sup>18</sup> McGettigan, "Factors Affecting the Selection...", 25.
- <sup>19</sup> *Ibid.*, 23.
- <sup>20</sup> ACI 515.2R-13 – Guide for Selecting Protective... 20-21.
- <sup>21</sup> McGettigan, "Factors Affecting the Selection...", 24.
- <sup>22</sup> *Ibid.*, 23.
- <sup>23</sup> Siloxanes has only 1 and 1 ½ silicon functional groups. *Ibid.*
- <sup>24</sup> *Ibid.*
- <sup>25</sup> *Ibid.*, 26.
- <sup>26</sup> Hurley, "Coatings...", 287.
- <sup>27</sup> ACI 515.2R-13 – Guide for Selecting Protective... 21.
- <sup>28</sup> Michael G. Grantham, "Corrosion inhibitors," in M. Grantham, ed., *Concrete Repair: A Practical guide*, (New York, NY: Taylor & Francis Group, 2011), 182.
- <sup>29</sup> Inorganic materials include nitrites, phosphates, among other components. Organic materials include amines and other organic compounds such as oxygen, nitrogen, sulfur, among others. Lastly, volatile materials are often seen in vapor phase inhibitors and include materials such as amino alcohols. Sike Ferroguard 903 is a product often for penetrating vapor phase. *Ibid.*, 177.
- <sup>30</sup> *Ibid.*
- <sup>31</sup> The application of vapor phase inhibitors through pellet holes is a highly invasive treatment on concrete. Its use should be considered as a last resource.
- <sup>32</sup> NSW Heritage Office, "The Investigation and Repair of Historic Concrete," (New South Wales, Australia, May 2003), 15.
- <sup>33</sup> Macdonald and Arato Gonçalves, *Conservation Principles...* 20-21.
- <sup>34</sup> Anne Grimmer, "The Preservation and Repair of Historic Stucco," *Preservation Briefs* 22 (Washington, DC: National Park Service, Preservation Assistance Division, 1990), 13.
- <sup>35</sup> American Shotcrete Association, "Shotcrete FAQs," *Shotcrete* 21, No. 4 (Fall 2019): 30.
- <sup>36</sup> Ashurst, *Mortars, Plasters and Renders...* 77.
- <sup>37</sup> Ivo Hammer, "The Original Intention – Intention of the Original?: Remarks on the Importance of Materiality Regarding the Preservation of the Tugendhat House and other Buildings of Modernism," in D. Van Den Heuvel, M. Mesnan, W. Quist & B. Lemmens, eds., *Challenge of Change: Dealing with the Legacy of the Modern Movement- Proceedings of the 10<sup>th</sup> International DOCOMOMO Conference*, (Amsterdam: Delft University Press & IOS Press, 2008), 369.



## BIBLIOGRAPHY

- A Manual of Concrete Masonry Construction: Concrete for Permanence*, Portland Cement Association, 1923.
- A Report on Municipalities of Puerto Rico: Cataño, Dorado, Toa Baja, Utuado, Vega Baja*. Commonwealth of Puerto Rico, Government Development Bank for Puerto Rico, May 1964.
- ACI 201.1R-08. "Guide for Conducting a Visual Inspection of Concrete in Service." Farmington Hills, MI: American Concrete Institute. 2008.
- ACI 506.4R-94. "Guide for the Evaluation of Shotcrete." Detroit, MI: American Concrete Institute. 1994.
- ACI 506R-16. "Guide to Shotcrete." Farmington Hills, MI; American Concrete Institute. 2016.
- ACI 515.2R-13. "Guide for Selecting Protective Treatments for Concrete." Farmington Hills, MI: American Concrete Institute. 2013.
- "ACI 524R– Guide to Portland Cement Plastering," *ACI Materials Journal* (Jan-Feb 1993).
- "ACI 805-51 – Recommended Practice for the Application of Mortar by Pneumatic Pressure," *Journal of the American Concrete Institute* (May 1951): 709-719.
- ACI CT-18. "ACI Concrete Terminology." Farmington Hills, MI: American Concrete Institute. March 2018.
- Allan, W.D.M. "Portland Cement Stucco Finishes-Report of Committee 401," *Journal of the American Concrete Institute-Proceedings*, (1929): 29-40.
- Allen, Leslie H. "New Materials and Methods of Construction as a Means of Reducing Costs," *The National Builder* 64, No. 2 (Feb 1921): 51.
- AL-Hashimi, Mohammed Noori Hussein, and Abdullah Najim, Wisan. "Performance of Concrete Containing Iron Fillings," *Journal of University of Babylon for Engineering Sciences* 26, No. 6 (2018): 384-392.
- Alzaed, A. "Effect of Iron Filings in Concrete Compression and Tensile Strength," *International Journal of Recent Development in Engineering and Technology* 3, No. 4 (Oct 2014): 121-125

- Approaches to the Conservation of Twentieth-Century Cultural Heritage: Madrid-New Delhi Document*. ICOMOS International Committee on Twentieth Century Heritage (ISC20C), 2007.
- Ashurst, John. *Mortars, Plasters and Renders in Conservation*. London, UK: RIBA Publications Ltd, 1983.
- ASTM C150-56. "Standard Specification for Portland Cement." West Conshohocken, PA: American Society for testing Materials. 1956.
- ASTM C206-14. "Standard Specification for Finishing Hydrated Lime." West Conshohocken, PA: ASTM International. 2014.
- ASTM C207-18. "Standard Specification for Hydrated Lime for Masonry Purposes." West Conshohocken, PA: ASTM International. 2018.
- ASTM C926-20. "Standard Specification for application of Portland Cement based plaster." West Conshohocken, PA: ASTM International. 2020.
- Balvanera Alfaro, Héctor. "Arquitectura Religiosa De Las Parroquias De La Arquidiócesis De San Juan De Puerto Rico, 1965-1995." Master's thesis, Universidad Popular Autónoma Del Estado De Puebla, 2019.
- Banthia, N. "Sprayed Concrete (Shotcrete)." In *Developments in the Formulation and Reinforcement of Concrete*, by Sidney Mindess. 1st ed. Duxford, UK: Woodhead Publishing, 2008.
- Beauty in the Walls of Architectural Concrete*. Chicago, IL: Portland Cement Association, 1936.
- Borroto Cáceres, J. La Plaza del Recreo Nuestra Señora Del Carmen y El Trazado de las Calles de Cataño. 2013. MS, Archivo Parroquial, Parroquia Nuestra Señora Del Carmen, Cataño, PR.
- Bronson, Susan D., and Thomas C. Jester. "Conserving the Built Heritage of the Modern Era: Recent Developments and Ongoing Challenges." *APT Bulletin: The Journal of Preservation Technology* 28, no. 4 (1997): 4. Accessed February 09, 2020.
- Bunaciu, Andrei A., Gabriela Udristioiu, Elena & Aboul-Enein, Hassan Y., "X-Ray Diffraction: Instrumentation and Applications," *Critical Reviews in Analytical Chemistry* 45, No. 4 (April 2015): 298.

- Burkhardt, Berthold. A Modern Movement in Engineering: Structural Developments in Architectural History" In *The Fair Face of Concrete: Conservation and Repair of Exposed Concrete: Proceedings International DOCOMOMO Seminar*, edited by Wessel De Jonge and Arjan Doolar. Eindhoven, Netherlands: Eindhoven University of Technology Printshop, 1998.
- Cartagena, Raúl. "El Control De Los Precios Del Saco De Cemento En Puerto Rico (1939-1984)." Master's thesis, University of Puerto Rico-Rio Piedras Campus, 2019.
- Catalá-Oliveras, Francisco. *Promesa rota: Una mirada institucional a partir de Tugwell*, San Juan, PR: Ediciones Callejón, 2013.
- Cement and Concrete Reference Book, 1956-1957*. Chicago, IL: Portland Cement Association, 1957.
- "Cement, Concreted Mortar and Related Products," *American Builder* 74, No. 4 (April 1952): 486.
- "Cement Gun - Technical Section 19 CONSTRUCTION DETAILS," *The Architect's Journal* (October 22, 1959): 391-396.
- Cesar, Ayala J., and Bernabé, Rafael. *Puerto Rico in the American Century: A History since 1898*. Chapel Hill, NC: University of North Carolina Press, 2007.
- Chadwick, W.L. "Hydraulic Structure Maintenance Using Pneumatically Placed Mortar," *Journal of the American Concrete Institute* 18, No. 5 (January 1947): 533-547.
- Childe, H. L. *Concrete Finishes and Decoration*. London, UK: Concrete Publications Limited, 1964.
- Christ-Janer, Albert, and Mary Mix Foley. *Modern Church Architecture: A Guide to the Form and Spirit of 20th Century Religious Buildings*. New York: McGraw-Hill, 1962.
- Color Tones in Stucco*. New York, NY: The Atlas Portland Cement Company, 1917.
- Concrete Data on Master Builders Products for Improving Concrete*, 4<sup>th</sup> Ed. Cleveland, OH: Master Builders Co., 1961.
- Concrete Manual – A Manual for the Control of Concrete Construction*. 7th Ed. Denver, CO: U.S. Department of the Interior, Bureau of Reclamation, 1963.

- Concrete Masonry Construction for Enduring and Firesafe Structures: Concrete for Permanence.* Portland Cement Association, 1935.
- Concrete Masonry Handbook for Architects, Engineers, Builders.* Chicago, IL: Portland Cement Association, 1951.
- Concrete Masonry Manual.* Washington, D.C.: Expanded Shale & Slate Institute, 1960.
- “Concrete: Report A on Cement SUGGESTED CONCRETE MIXES Machines for Concrete Construction,” *American Builder* 72, No. 6 (June 1950): 78
- “Contractors’ Power Equipment: Construction Work Speeded Up and Costs Lowered by Many Appliances Useful and Profitable to the Builder,” *American Builder* 37, No. 3 (June 1924): 366.
- Cowan, Henry. and Smith, Peter. *The Science and Technology of Building Materials.* New York, NY: Van Nostrand Reinhold, 1988.
- Dalzell, J Ralph. “Do it Yourself: Stucco Wall Cracks Repaired,” *The Sun* (Baltimore: Aug 1954): 80
- Dean, Yvonne. *Mitchells’ Building Series Materials Technology.* Essex, UK: Addison Wesley Longman Limited/Antony Rowe Ltd, 1996.
- “Definitions of Key Shotcrete Terminology,” *Shotcrete Magazine* 14, No. 3 (Summer 2012): 27-29.
- Del Cueto, Beatriz. “Concrete Block and Hydraulic Cement Floor Tile in the Tropics: advents, history, conservation.” New York, NY: James Marston Fitch Charitable Foundation, June 2015.
- . Conservation Methodology for Historic Buildings-Puerto Rico & Virgin Islands: Technical Spanish-English Glossary. 2007. MS, San Juan, PR.
- Devane, Andrew, and Albert Gutheim, Frederick. *In the Cause of Architecture, Frank Lloyd Wright: With a Symposium on Architecture with and without Wright, by Eight Who Knew Him.* New York: Architectural Record Books, 1974.
- Dietz, James L. *Historia Económica De Puerto Rico.* Río Piedras, PR: Ediciones Huracán, 1989.

- Dutrow, Barbara L., and Christine M. Clark. "X-ray Powder Diffraction (XRD)." *Geochemical Instrumentation and Analysis*. Accessed February 3, 2020. [https://serc.carleton.edu/research\\_education/geochemsheets/techniques/XRD.html](https://serc.carleton.edu/research_education/geochemsheets/techniques/XRD.html).
- Eckhouse, Robert D. *The Wise Handbook of Masonry and Waterproofing*. New York, NY: WM. H. Wise & Co., Inc., 1952.
- Feilden, Bernard M. *Conservation of Historic Buildings*, 3<sup>rd</sup> Ed. Oxon, UK: Architectural Press/Taylor & Francis Group, 1994.
- Fernández-Vázquez, Jose. "Henry Klumb: Tropical Probes." *The Modernism Magazine* 9, no. 2 (2006).
- Fitzgerald, Ed. "Condition Assessment: Tips for Historic Building Owners." National Park Service. August 31, 2010. Accessed January 10, 2020. <https://www.ncptt.nps.gov/blog/condition-assessments-tips-for-historic-building-owners/#:~:text=Condition Assessments: Tips for Historic Building Owners,-Posted by Ed&text=Condition assessments are a holistic,their structural and material condition.>
- Friedman, Edward L. "Search," *Progressive Architecture* 41, no. 10 (October 1960): 160-165.
- For applying Plaster-Stucco-Waterproofing*. Cincinnati, OH: Hodges Stucco Machine Works, 1925.
- Fourth National Climate Assessment*. Washington D.C.: U.S. Government Publishing Office, 2018, 819-840.
- Gala Aguilera, Santiago. "El Comité de Diseño de Obras Públicas 1943-1948," *Entorno* 7, Colegio de Arquitectos y Arquitectos Paisajistas de Puerto Rico (2007): 24-28.
- Gapper, Claire and Orton, Jeff. "Plaster, Stucco and Stuccoes," *Journal of Architectural Conservation* 17, No. 3 (2011): 7-22.
- Gaudette, Paul & Slaton, Deborah. *Preservation Briefs* 15: Preservation of Historic Concrete. Washington, DC: National Park Service, Heritage Preservation Services, 2007.
- Gierbolini Rodríguez, Arnaldo. *Resumen De La Historia De La Iglesia En Puerto Rico Y Esbozo De Las Historias Diocesanas*. Proceedings of Primer Encuentro De La Asamblea Nacional De Pastoral in Casa Manresa. Aibonito, PR, 2011. 13-15.

- Giese, Henry. *A Practical Course in Concrete*. Chicago, IL: Portland Cement Association, 1948.
- Glassgold, I.L. *SP 128-19 Shotcrete in the United States: A Brief History*. American Concrete Institute, 1991.
- Grimmer, Anne E. *Keeping It Clean: Removing Exterior Dirt, Paint, Stains and Graffiti from Historic Masonry Buildings*. Washington, DC: National Park Service, Technical Preservation Services, 1988.
- . Preservation Briefs 22: The Preservation and Repair of Historic Stucco. Washington: U.S. Dept. of the Interior, National Park Service, Preservation Assistance Division, 1990.
- Guide to Good Stucco with Specifications*. New York, NY: The Atlas Portland Cement Company, 1916.
- "Gunite," *The National Builder* 66, No. 2 (February 1923): 74.
- Gunite: A Handbook of Cement Gun Work*. London, UK: The Concrete Proofing Co. LTD., 1934.
- Hadden, David. "Cleaning Restoration of the Baha'I House of Worship," *Concrete International* 14, No. 9 (September 1992): 46-47.
- Hall, Bert A. "Crack Control in Portland Cement Plaster," *Journal of the American Concrete Institute* 19, No. 2, (Oct 1947): 129.
- Harris, Cyril M., ed. *Dictionary of Architecture and Construction*. New York, NY: McGraw Hill, 1975.
- Hebert Gibson, W. *Concrete Design and Construction*. 2<sup>nd</sup> Ed. Chicago, IL: American Technical Society, 1945.
- Henket, Hubert-Jan. "Opening." In *The Fair Face of Concrete: Conservation and Repair of Exposed Concrete: Proceedings International DOCOMOMO Seminar*, edited by Wessel De Jonge and Arjan Doolar. Eindhoven, Netherlands: Eindhoven University of Technology Printshop, 1998.
- Henry, Alison, and Stewart, John. *Mortars, Renders and Plasters*. Practical Building Conservation. Farnham, UK: Ashgate/Historic England, 2011.
- Hering, Oswald C. *Building Concrete & Stucco Houses*. New York, NY: Robert M. McBride & Co., 1929.

- Hering, Oswald C. *Concrete and Stucco Houses: The Use of Plastic Materials in the Building of Country and Suburban Houses in a Manner to Insure the Qualities of Fitness, Durability and Beauty*. New York, NY: McBride, Nast & Company, 1912.
- Hitchcock, Henry- Russell. "Latin American Architecture," *Journal of the Royal Society of Arts* 104, no. 4973, (March 1956): 344-356.
- Hornbostel, Caleb. *Materials for Architecture- An Encyclopedic Guide*. New York, NY: Reinhold Publishing Corporation, 1965.
- Hurley, Shaun A. "Coatings for Concrete." In *Concrete Repair: A Practical guide*, edited by Michael G. Graham. New York, NY: Taylor & Francis Group, 2011.
- Huxtable, Ada Louise. "Historical Survey," *Progressive Architecture* 41, no. 10 (October 1960): 144-149.
- Huyke-Luigi, R. SP 139-10 - Strength of Concrete Cured Under Various Conditions in Tropical Climates. In *SP-139: Durable Concrete in Hot Climates*, edited by Cameron MacInnis. San Juan, PR: The International Symposium on How to Produce Durable Concrete in Hot Climates, September 1993. 170.
- "Improvement in Concrete Work," *The Contract Record* 22, No. 45 (November 1908): 18.
- Ingham, Jeremy P. *Geomaterials Under the microscope: A Colorful Guide*. Boca Ratón, FL: CRC Press-Taylor & Francis Group, LLC/Manson Publishing, 2011.
- Introduction to Sprayed Concrete*. Hampshire, UK: Sprayed Concrete Association, 1999.
- Jana, Dipayan. *Concrete Petrography-Past, Present, and Future*. Proceedings of the 10<sup>th</sup> Euroseminar on Microscopy Applied to Building Materials (EMABM), Paisley, Scotland: 21-24 June 2005.
- Jeanne Marie Teutonico, *A Laboratory Manual for Architectural Conservators*. Rome: ICCROM-International Centre for the Study of the Preservation and the Restoration of Cultural Property, 1988.
- Jester, Thomas C., and Fixler, David N., "Modern Heritage: Progress, Priorities, and Prognosis," *APT Bulletin: The Journal of Preservation Technology* 42, no. 2/3, (2011): 3. Accessed February 09, 2020.
- John H. Pye, *Chapter 53 – "Shotcrete."* In *STP- 169D – Significance of Tests and Properties of Concrete and Concrete-Making Materials*, edited by J. Lamond and J. Pielert. ASTM International, May 2006.

- Jonge, W. de, and Doolar, Arjan, eds. *The Fair Face of Concrete: Conservation and Repair of Exposed Concrete: Proceedigs of the International DOCOMOMO Seminar*. Eindhoven, Netherlands: Eindhoven University of Technology Printshop, 1998.
- Joshi, Kiran, ed. *Corbusier's Concrete: Challenges of Conserving Modern Heritage- Proceedings of Seminar on Conservation of Le Corbusier's Work in Concrete, Chandigarh, 11-13 February 2002*. Chandigarh: Chandigarh Perspectives/Chandigarh College of Architecture, 2005.
- Klumb, Henry. *My Architectural Design Philosophy*. Celebration of Architecture Florida Design '79 - 65th Annual FAIA Convention. Florida. October 2, 1979.
- Komendant, Auguste. "Possibilities," *Progressive Architecture* 41, no. 10 (October 1960): 178-185.
- Kubal, Michael T. *Construction Waterproofing Handbook*. New York, NY: McGraw-Hill, 2000.
- "Lining Ditches with Reinforced Concrete - Gunite mortar," *Concrete-Cement Age* 2, No. 6 (June 1913): 265.
- Lizardi Pollock, Jorge. "Daños Colaterales: Utopía, Ciudad Y Suburbio En Tiempos De Guerra Fría (1942-1972)." In *Tiempos Binarios: La Guerra Fría Desde Puerto Rico Y El Caribe*, edited by Manuel R. Rodríguez Vazquez and Silvia Álvarez Curbelo. San Juan, PR: Ediciones Callejón, 2017.
- , et.al. "Paisajes De La Contingencia: Arquitectura Y Urbanismo En San Juan, 1938-1948." In *Puerto Rico En La Segunda Guerra Mundial: El Escenario Regional*, edited by Jorge Rodríguez-Beruff and José L. Bolívar-Fresneda. San Juan, PR: Ediciones Callejón, 2015.
- Loewenberg, Yael. "Historic Concrete Finishes 1900-World War II." Master's thesis, Columbia University, 1987.
- Lorman, William R. "Engineering Properties of Shotcrete." In *NCEL Technical Report R429 with Addendum- ACI Publication SP-14A*. Detroit, MI: American Concrete Institute, December 1968.
- "Low-Cost Housing with Style and Quality Tucson AZ," *American Builder* (May 1949): 112-114.
- Lowndes, W.S. *Plaster and Plastering*. Philadelphia, PA: David McKay Company, 1924.



- Ludwig, Udo. Durability of Cement Mortars and Concretes. In *ASTM STP 691 - Durability of Building Materials and Components*, edited by P. J. Sereda and G. G. Litvan. Detroit, MI: American Society for Testing and Materials, 1980. 270.
- Macdonald, Susan. "Authenticity Is More than Skin Deep: Conserving Britain's Postwar Concrete Architecture," *APT Bulletin: The Journal of Preservation Technology* 28, No. 4 (1997): 37-44.
- , ed. *Concrete Building Pathology*. London, UK: Wiley-Blackwell, 2002.
- and Arato Gonçalves, Ana Paula. *Conservation Principles for Concrete of Cultural Significance*. Los Angeles: Getty Conservation Institute, 2020.
- Mack, Robert C. & Grimmer, Anne E. *Preservation Briefs 1: Assessing Cleaning and Water-Repellent Treatments for Historic Masonry Buildings*. Washington, DC: National Park Service, Heritage Preservation Services, 2000.
- Marvel, Thomas S. "Cómo fue concebido el libro de La Arquitectura de Templos Parroquiales en Puerto Rico." *Patrimonio* 5, Oficina Estatal de Conservación Histórica de Puerto Rico (2012): 63.
- Marqués Mera, Lelis. "Cuando nació el Caribe Hilton; notas sobre el Diseño Industrial en Puerto Rico", *Entorno 7: Colegio de Arquitectos de Arquitectos y Arquitectos Paisajistas de Puerto Rico* (2007): 12-15.
- Martin, I. and Olivieri, E. *Curing of Concrete in Puerto Rico*. Mayaguez, PR: Colegio de Agricultura y Artes Mecánicas, Universidad de Puerto Rico, 1964.
- Martinez, M. R. Correlation Between the Strength of Standard Molded Cylinders and Small Drilled Concrete Cores Cured Under Field Conditions. In *Publication ICO-R101*. Mayaguez, PR: Construction Institute, 1971.
- "Materials FAQs." Stucco Frequently Asked Questions. Accessed July 8, 2020. <https://www.cement.org/learn/materials-applications/stucco/stucco-frequently-asked-questions>.
- McCaughan, Frank A. "Pneumatic Application of Cement-Mortar Tank Coatings," *Journal- American Water Works Association* 57, No. 9 (September 1965): 1145-1148.
- Mehta, P.K. ed. *STP-663 – Cement Standards-Evolution and Trends*. ASTM Special Technical Publication 663. Philadelphia, PA: American Society for Testing and Materials, 1978.

- Melander, John M., Farny, James A., and Isberner, Albert W. *Portland Cement Plaster/Stucco Manual*. Skokie, IL: Portland Cement Association, 2003.
- Michael G. Grantham, "Corrosion inhibitors." In *Concrete Repair: A Practical guide*, edited by Michael G. Graham. New York, NY: Taylor & Francis Group, 2011.
- Moavenzadeh, Fred. ed., *Concise Encyclopedia of Building Materials*. Exeter, UK: BPC Wheatons Ltd, 1990.
- Modern Modes in Better Plastering: Period-textured plastering is now accorded due to recognition as a great Renaissance in American Architecture*. Milwaukee, WI: Milwaukee Corrugating Company, 1926.
- Moore, Charles W. "Plaster in Architecture." In *Manual of Lathing and Plastering*, by John R. Diehl, 4-30. New York, NY: Gypsum Assoc. - National Bureau of Lathing and Plastering, 1965.
- Morales Muñoz, Generoso Eduardo. *Fundación del Pueblo De Cataño, Documentos y Comentarios*. San Juan, PR: Talleres Gráficos de la Imprenta Venezuela, 1946.
- Morales-Vega, Mathew A. *Terremoto Y Maremoto De 1918: Una Mirada a La Respuesta Gubernamental Ante La Catástrofe*. 2018. MS, University of Puerto Rico, San Juan.
- Morgan, Dudley R. "Advances in Shotcrete Technology for Infrastructure Rehabilitation," *Shotcrete* (Winter 2006): 18.
- Morillas, Héctor, França de Mendonça Filho, Fernando, Derluyn, Hannelore, Maguregui, Maite, Grégoire, David, and Madariaga, Juan Manuel. "Decay processes in buildings close to the sea induced by marine aerosol: Salt depositions inside construction materials," *Science of the Total Environment* 721 (2020).
- Normandin, Kyle. "Physical Conservation Challenges Facing Modern Architecture." In *Experts Meeting: A Colloquium to Advance the Practice of Conserving Modern Heritage*, edited by Kyle Normandin and Susan Macdonald. Los Angeles, CA: Getty Conservation Institute, March 6-7, 2013: 42. Accessed February 09, 2020.
- Nordmeyer, Herb. *The Stucco Book: The Basics*. Castroville, TX: Nordmeyer LLC, 2012.
- Odgers, David, ed. *Concrete. Practical Building Conservation*. Farnham, UK: Ashgate/Historic England, 2012.
- Olutoge, F. Adeyemi, Onugba, M. Attah, and Ocholi, A. "Strength Properties of Concrete Produced with Iron Filings as Sand Replacement," *British Journal of Applied Science and technology* 18, No. 3 (January 2017).

- Otero, Rosa D. "Permeable Walls and Place Recognition in Henry Klumbs Architecture of Social Concern." Ph.D. diss., University of Pennsylvania, 2005.
- Pérez Chanis, Efraín. "Arquitectura: Génesis Y Ruta De La Arquitectura En Puerto Rico." In *La Gran Enciclopedia De Puerto Rico*, edited by Vicente Báez. Vol. 9. Arquitectura/Leyes. San Juan, PR: Puerto Rico En La Mano & La Gran Enciclopedia De Puerto Rico, 1976.
- . "Arquitectura Religiosa en Puerto Rico," *URBE* 32, (December 1968-January 1969): 24-25.
- "Parish Church on a Caribbean Plaza: Del Carmen Church, Cataño, Puerto Rico: Henry Klumb, Architect," *Progressive Architecture* 44, no. 11 (1963): 140-141.
- Pender, Robyn, Ridout, Brian, and Curteis, Tobit, ed. *Building Environment*. Practical Building Conservation. Farnham, UK: English Heritage, 2014.
- Pérez Escolano, Victor. "A European Glance in the Mirror of Caribbean Modern Architecture," *DoCoMoMo International Journal*, no. 33 (September 2005): 87
- "Placing Cement Coating with the Cement Gun," *The Construction News* 33, No. 3 (Jan 20, 1912): 16.
- "Placing Concrete by Pumping Methods – Reported by ACI Committee 304," *ACI Journal* (May 1971): 327-347.
- "Pneumatic Equipment for Placing Cement Mortar," *Concrete-Cement Age* 4, No. 1 (January 1914): 45.
- Poole, Alan B., and Ian Sims. *Concrete Petrography: A Handbook of Investigative Techniques*. 2nd ed. Boca Raton, FL: CRC Press, 2016.
- "Popularity of Stucco," *Concrete - Cement Age* 7, No. 4, (Oct 1915): 131.
- Portland Cement Stucco Surfacing* Portland Cement Association, 1927.
- "Proposed ACI Standard Recommended Practice for Shotcreting," *Journal of the American Concrete Institute* 63, No. 2 (February 1966): 219-246.
- "Proposed Revision of ACI 605-59: Recommended Practice for Hot Weather Concreting," *ACI Journal*, (July 1971): 489-503.

- "Puerto Rico and the U.S. Virgin Islands." State Climate Summaries 149-PR, NOAA National Centers for Environmental Information. 2019. Accessed April 20, 2020. <https://statesummaries.ncics.org/chapter/pr/>.
- Pumarada O'Neill, Luis. "Historic Bridges of Puerto Rico, c. 1840-1950." National Register of Historic Places Inventory/Nomination Form. Arqueología Industrial Caribeña, San Germán, PR: June 13th, 1995.
- Rasheeduzzafar and Ali, M.G. SP 139-2-Effect of Temperature on Cathodic Protection Criterion for Reinforced Concrete Structures. In *SP-139: Durable Concrete in Hot Climates*, edited by Cameron MacInnis. San Juan, PR: The International Symposium on How to Produce Durable Concrete in Hot Climates, September 1993. 21.
- Rigau, Jorge. "Architecture of the 1960s in Puerto Rico, 1958-1972." National Register of Historic Places Multiple Property Documentation Form. Jorge Rigau Arquitectos PSC, San Juan, PR, July 3<sup>rd</sup>, 2019.
- . "Early XXth Century Schools in Puerto Rico" National Register of Historic Places Multiple Property Documentation Form. Jorge Rigau Arquitectos, San Juan, PR, August 2<sup>nd</sup>, 2012.
- RLA Conservation, Inc., John Fidler Preservation Technology, Inc. and Lynch & Ferraro Engineering, Inc. "Final Report – MMS-CONSOL: Concrete Solutions: A standard-setting project for graffiti management, surface cleaning and patch repair of historic concrete, utilizing the Miami Marine Stadium as a test site." Los Angeles: Getty Conservation Institute, 2016.
- Rodríguez, Luz Marie. "Klumbumbus descubre el Trópico: Henry Klumb, Puerto Rico y la arquitectura de lo existente" *Arquitectos* 120, Year 10 (May 2010). Accessed February 15, 2020. <https://72.10.48.168/revistas/read/arquitectos/10.120/3415>.
- . "Sanctuary of Blessed Martín de Porres." National Register of Historic Places Registration Form. Puerto Rico State Historic Preservation Office, San Juan, PR: November 11<sup>th</sup>, 2017.
- . "¡Vuelo Al Porvenir! Henry Klumb Y Toro Ferrer: Proyecto Moderno Y Arquitectura Como Vitrina De La Democracia [Puerto Rico, 1944-1958]." PhD diss., Universidad Politécnica de Cataluña, 2008.
- Rodríguez-León, Mario. "Historia De Los Frailes Dominicanos En Puerto Rico: 1509-2009." PReb. 2009. Accessed February 15, 2020. <https://www.preb.com/devisita/domenpr.htm>.

- Rodriguez, Louis. *From Elephants to Swimming Pools: Cark Akeley, Samuel W. Traylor and the Development of the Cement Gun*. Easton, PA: Canal History and Technology Press, 2006.
- Rudder, Thomas H. "The Cleaning of Masonry Buildings," *Concrete Repair Bulletin* (January/February 2005): 18-19.
- Ryan, T.F. *Gunite: a handbook for engineers*. London, UK: Cement and Concrete Association & T.H. Brickell & Son Ltd., The Blackmore Press, 1973.
- Sandoval Martínez, Diana Jean. *Concrete Colonialism: Architecture, Infrastructure, Urbanism, and the American Colonization of the Philippines*. Ph.D. diss., Columbia University, 2017. New York, NY. Accessed October 20, 2019. <https://academiccommons.columbia.edu/doi/10.7916/D88P6BXX>.
- Satyaprakash, Helmand, Pashtoon, and Saini, Shiha. "Mechanical properties of concrete in presence of iron filings as complete replacement of fine aggregates," *Materials Today: Proceedings* 15 (2019): 536-545
- Seegebrecht, George. "The Evolution of Shotcrete Evaluation and Testing" *Shotcrete* (Fall 2017): 50.
- Sepúlveda, Aníbal. *Puerto Rico urbano: Atlas histórico de la ciudad puertorriqueña, vol 4: 1920s-2000s*. San Juan, PR: Centro de investigaciones CARIMAR, 2004.
- "Shotcrete FAQs," *Shotcrete* 21, No. 4 (Fall 2019): 30.
- Smith, Randall. "Don't Blame Vatican II: Modernism and Modern Catholic Church Architecture." *Sacred Architecture* 13, The Institute of Sacred Architecture, (2007). Accessed February 15, 2020. <https://www.catholicculture.org/culture/library/view.cfm?recnum=8000>
- Solar Radiation Data Manual for Buildings*. Golden, CO: National Renewable Energy Laboratory, Midwest Research Institute, September 1995, 190.
- "Standards for Installation of Plaster." Stucco Installation Standards. Accessed July 8, 2020. <https://www.cement.org/learn/materials-applications/stucco/stucco-installation-standards>.
- Stratte, Sara Jane. "An Evaluation of Historic Cement Stucco Using Conditions Assessment Methodology and Digital Visualization Tools, Grand Teton National Park, USA." Master's thesis, University of Pennsylvania, 2018.
- Struik, Félix. Centenario de la Parroquia del Carmen de Cataño 1893-1993. 1993. MS, Archivo Parroquial, Parroquia Nuestra Señora del Carmen, Cataño, PR.

Stucco. Accessed July 8, 2020. <https://www.cement.org/cement-concrete-applications/paving/buildings-structures/concrete-homes/products/stucco>.

"Stucco and Concrete Coatings," *American Builder* 75, No. 4 (April 1953): 83.

"Stucco and Moisture Resistance." Performance of Stucco. Accessed July 8, 2020. <https://www.cement.org/learn/materials-applications/stucco/performance-of-stucco>.

*Stucco Investigations at the Bureau of Standards with Recommendations for Portland Cement-Stucco Construction-Circular of the Bureau of Standards, No. 311.* Washington, D.C.: U.S. Department of Commerce, Bureau of Standards, Dec 1926.

Sullivan, Anne T. "Shotcrete." In *Twentieth Century Building Materials-History and Conservation*, edited by Thomas C. Jester. 2<sup>nd</sup> Ed. Los Angeles: Getty Conservation Institute, 2014.

Swanke Hayden Connell Architects. *Historic Preservation: Project Planning & Estimating*. Kingston, MA: R.S. Means, 2000.

Swapp, Susan. "Scanning Electron Microscopy (SEM)." *Geochemical Instrumentation and Analysis*. Accessed on February 3, 2020, [https://serc.carleton.edu/research\\_education/geochemsheets/techniques/SEM.html](https://serc.carleton.edu/research_education/geochemsheets/techniques/SEM.html)

Teichert, Pietro. "Carl Akeley- A Tribute to the Founder of Shotcrete," *Shotcrete* (Summer 2002): 11

Tomlan, Michael A. "Introduction-Building Modern America: An Era of Standardization and Experimentation." In *Twentieth Century Building Materials-History and Conservation*, edited by Thomas C. Jester. 2<sup>nd</sup> Ed. Los Angeles: Getty Conservation Institute, 2014.

*The Cement Gun in Building Construction - Bulletin 114*. Allentown, PA: Cement Gun Company, Inc.

*The Investigation and Repair of Historic Concrete*. New South Wales, Australia: NSW Heritage Office, May 2003.

*The Romance of Cement*. Boston, MA: Edison Portland Cement Co., 1926.

- The Stucco House: A Book for those about to build- Owner, Architect, Builder.* New York, NY: The Atlas Portland Cement Company, 1921.
- Tugwell, Rexford G. *The Stricken Land: The Story of Puerto Rico.* New York: Greenwood Press, 1977.
- Van Den Heuvel, D., Mesnan, M., Quist, W., and Lemmens, B., eds. *Challenge of Change: Dealing with the Legacy of the Modern Movement- Proceedings of the 10th International DOCOMOMO Conference.* Amsterdam: Delft University Press & IOS Press, 2008.
- Vivoni-Farage, Enrique. "Henry Klumb Y La Exuberancia Poética En La Arquitectura/Henry Klumb and Poetic Exuberance in Architecture." In *Klumb: Una Arquitectura De Impronta Social/An Architecture of Social Concern*, edited by Enrique Vivoni-Farage. San Juan, PR: Editorial UPR, 2006.
- Vivoni Farage, Enrique. "La Arquitectura del movimiento moderno en Puerto Rico: La obra de Toro y Ferrer y Henry Klumb," *Editorial Online* (July 2012).
- Vivoni-Farage, Enrique. "Modern Puerto Rico and Henry Klumb," *DoCoMoMo International Journal*, no. 33 (September 2005): 30.
- Vivoni-Farage, Enrique, ed. *San Juan Siempre Nuevo: Arquitectura Y Modernización En El Siglo XX = Ever New San Juan: Architecture and Modernization in the Twentieth Century.* San Juan, PR: Editorial de la Universidad De Puerto Rico, 2000.
- Vivoni-Farage, Enrique, and Álvarez-Curbelo, Silvia, eds. *Ilusión De Francia: Arquitectura Y Afrancesamiento En Puerto Rico.* San Juan, PR: Archivo De Arquitectura Y Construcción De La Universidad De Puerto Rico, 1999.
- Vollono Drapala, Lauren. "Rediscovering an American Master: An Examination and Analysis of the Decorative Plaster Ceiling of Robert Winthrop Chanler's Whitney Studio, New York." Master's thesis, University of Pennsylvania, 2010.
- Warner, James. "Understanding Shotcrete-The Fundamentals," *Concrete International* (May 1995): 59-64.
- Watt, David S. *Building Pathology – Principles and Practice.* 2<sup>nd</sup> Ed. London, UK: Wiley-Blackwell, 2008.
- Weaver, Martin E. *Conserving Buildings: A Manual of Techniques and Materials.* 2<sup>nd</sup> Ed. New York, NY: John Wiley & Sons, Inc., 1997.

Weiss, Norman. *Draft - Exterior Cleaning of Historic Masonry Buildings*. Washington, DC: U.S. Department of the Interior, National Park Service, 1985.

Wells, Jeremy C. "History and Characterization of Mortars in Spanish New World Fortifications: A Case Study on El Castillo de San Cristobal, San Juan, Puerto Rico." Master's thesis, University of Pennsylvania, 2004.

Wiesner-Chianese, Julianne. "Modern in the Mountains: An Analysis of the Structural and Decorative Concrete at Jackson Lake Lodge in Grand Teton National Park, WY." Master's thesis, University of Pennsylvania, 2015.

Wilson, J. Gilchrist. *Exposed Concrete Finishes: Finishes to In-Situ Concrete*. Vol. 1. London: CR Books, 1964.

Wright, Gwendolyn. "Introduction." In *Klumb: Una Arquitectura De Impronta Social/An Architecture of Social Concern*, edited by Enrique Vivoni-Farage. San Juan, PR: Editorial UPR, 2006.

Yoggy, George D. "The History of Shotcrete," *Shotcrete* (Summer 2005): 28.

Yusuf, M.O. "Microstructure and strength of iron-filing Portland cement paste and mortar" *Magazine of Civil Engineering* 90, No. 6 (2019): 28-36.

Zeitung, Tonindustrie. "A German Cement Gun," *Cement Age* 8, No.4 (October 1911): 175.

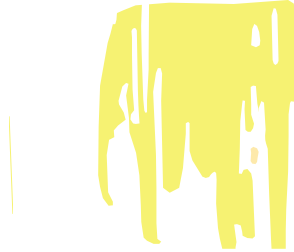
Zorilla, Aida. "Construyen En Cataño Primera Iglesia En Forma Hexagonal." *El Mundo* (San Juan, PR), May 26, 1962.



## **APPENDIX 1**

### CONDITIONS GLOSSARY

## CONDITIONS GLOSSARY



### BIO-FOULING

Blackening of the surfaces due to the deposition of airborne pollution or other materials. Very thin layer of deposit.



### BIRD GUANO

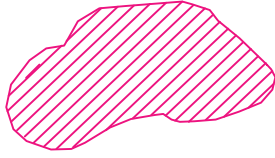
Accumulated excrement of pigeons, seabirds and bats. There is a considerable presence of pigeons and nests in the site.



### METALLIC STAINING

Colored staining derived from the oxidation/weathering of metallic sources either intrinsic or extrinsic. Typically, yellow (iron).





### DETACHMENT/DEBONDING OF RENDER

Hollowness, poor or loss of adhesion of the render to the concrete substrate (wall). These areas were marked with white chalk over the surfaces.



### DISCOLORATION

Discoloration of paint layers in render surfaces on selected areas.



### PEELING OF PAINTING

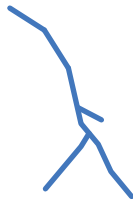
Peeling (shedding off ) of paint coatings. Usually, the paint forms a nonbreathable coating. Moisture accumulation due to presence of a coating with limited vapor permeability leads to the separation of paint from the substrate.





#### HAIRLINE CRACK

Hairline or thin cracks with opening less than 1/32" and are barely perceptible.



#### SLIGHT CRACK

Slight (Small) cracks are those with opening between 1/32" and 3/16"



#### LARGE CRACK

Cracks larger than 3/16"





### MACROFLORA

The presence of large leafy plants and ferns on the building. Associated to open joints and areas containing enough moisture to sustain plant life.



### PREVIOUS REPAIRS

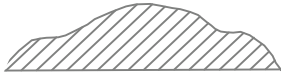
A mortar or resin-based treatment system used as a surface repair for spalls, cracks and losses.



### SURFACE LOSS / LOSS OF RENDER

Loss of render along the exterior surface layers (of various sizes and depth).





### RISING DAMP DAMAGE

Rising damp is the upward movement of moisture through walls and some-times floors by capillary action from below the ground. It can rise to one or more walls, depending on the masonry type, water table level and evaporation rate.



### ROOF COATING

Monolithic, fully bonded, liquid based roof coating that forms a rubber-like elastomeric waterproof membrane. The coating is found almost all over the roof and dome.



## **APPENDIX 2**

### CONDITIONS ASSESSMENT

CONDITIONS ASSESSMENT

# Parroquia Nuestra Señora del Carmen

1962

42 CALLE EL TREN, CATAÑO, PUERTO RICO, 00962

DRAWN BY: HECTOR J. BERDECIA-HERNANDEZ  
UNIVERSITY OF PENNSYLVANIA  
GRADUATE PROGRAM IN HISTORIC PRESERVATION, SCHOOL OF DESIGN

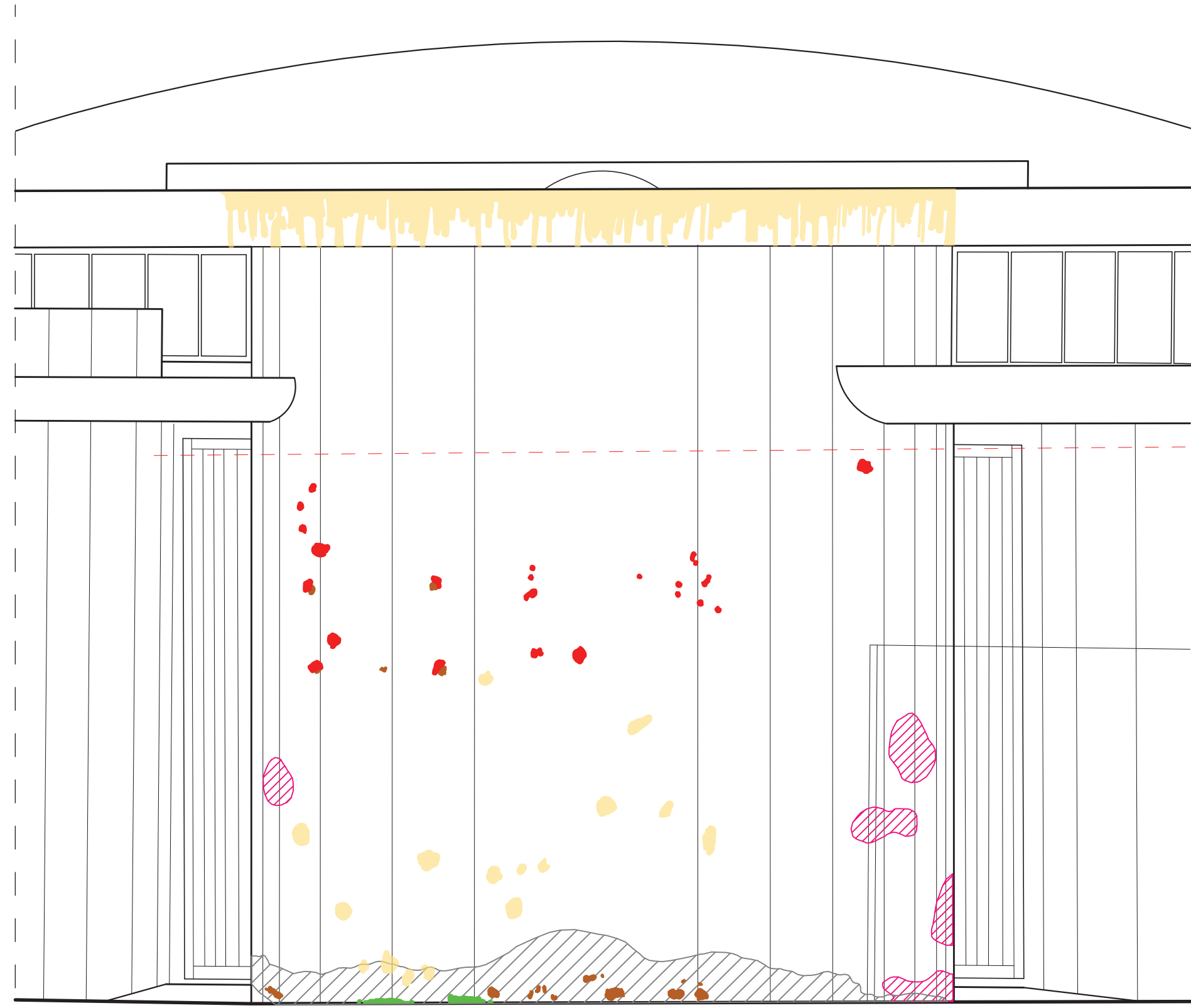
PARROQUIA NUESTRA SEÑORA DEL CARMEN  
42 CALLE EL TREN, CATAÑO, P.R., 00962

SURVEY NO.

CONDITIONS  
ASSESSMENT  
SHEET 0 OF 26 SHEETS

DATE  
JUN 1, 2020





HEIGHT LIMITATION FOR ASSESSMENT

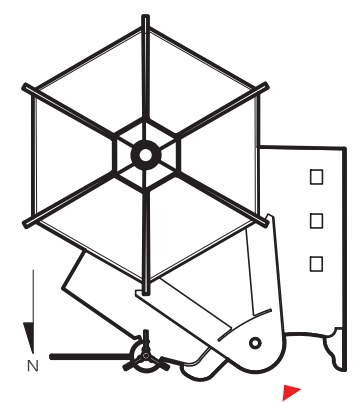
CONDITIONS

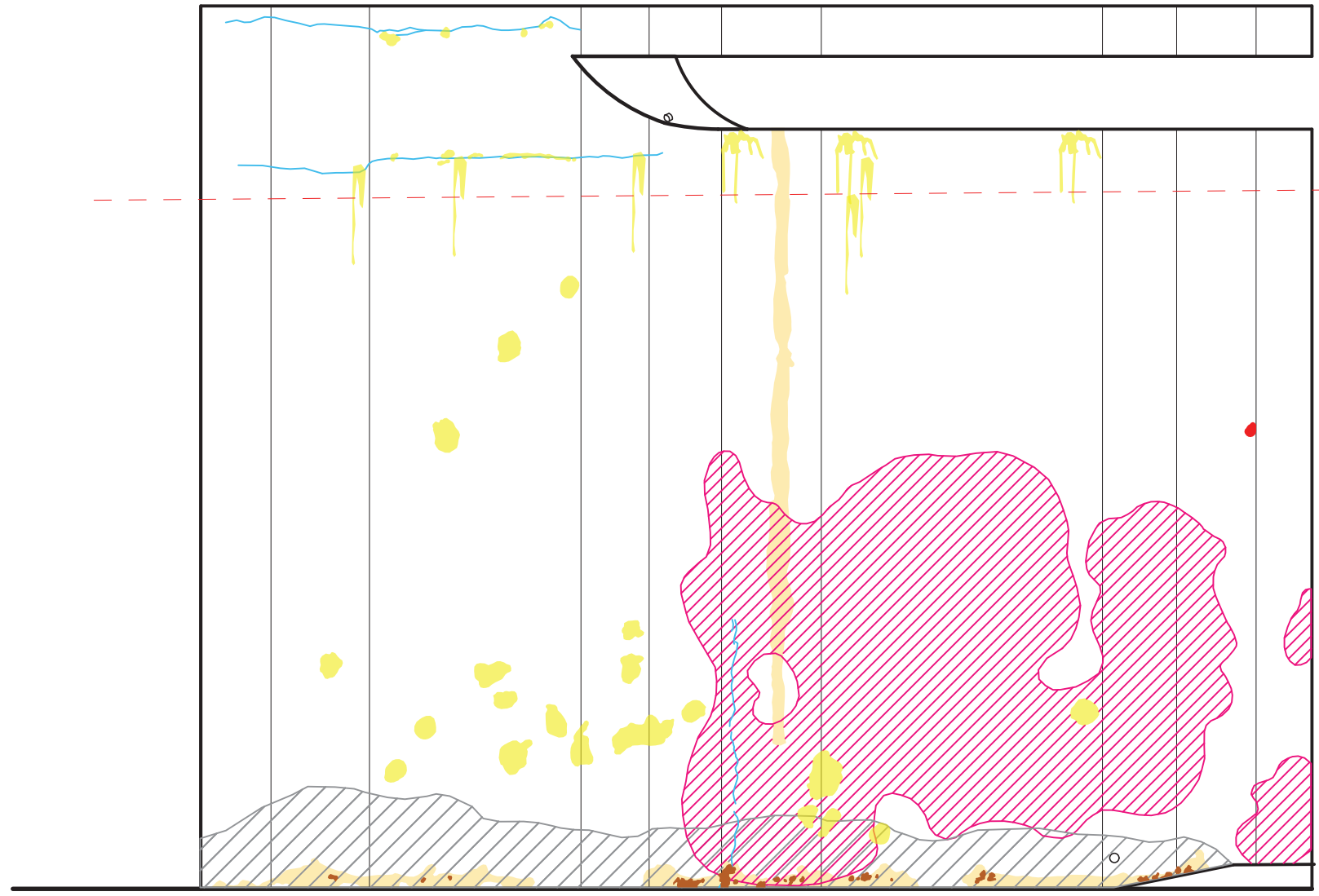
- |                      |                    |
|----------------------|--------------------|
| BIO-FOULING          | HAIRLINE CRACK     |
| BIRD GUANO           | SLIGHT CRACK       |
| METALLIC STAINING    | LARGE CRACK        |
| DETACHMENT/DEBONDING | MACROFLORA         |
| LOSS OF RENDER       | PREVIOUS REPAIR    |
| DISCOLORATION        | RISING DAMP DAMAGE |
| PEELING OF PAINTING  | ROOF COATING       |

1 - NORTHWEST ELEVATION  
SCALE 1'-0" = 3/8"

















MATERIALS - FINISH & SUBSTRATE: WALL - REINFORCED CONCRETE BLOCKS  
EAVES - CAST-IN-PLACE CONCRETE  
PORTLAND CEMENT STUCCO ON WALL



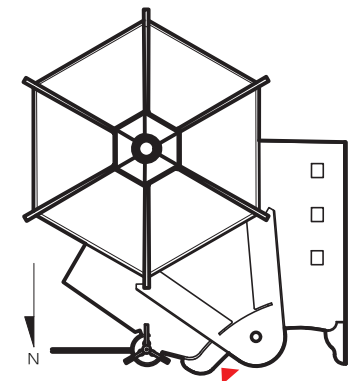


HEIGHT LIMITATION  
FOR ASSESSMENT

CONDITIONS

- |  |  |
|--|--|
|  BIO-FOULING          |  HAIRLINE CRACK     |
|  BIRD GUANO           |  SLIGHT CRACK       |
|  METALLIC STAINING    |  LARGE CRACK        |
|  DETACHMENT/DEBONDING |  MACROFLORA         |
|  LOSS OF RENDER       |  PREVIOUS REPAIR    |
|  DISCOLORATION        |  RISING DAMP DAMAGE |
|  PEELING OF PAINTING  |  ROOF COATING       |

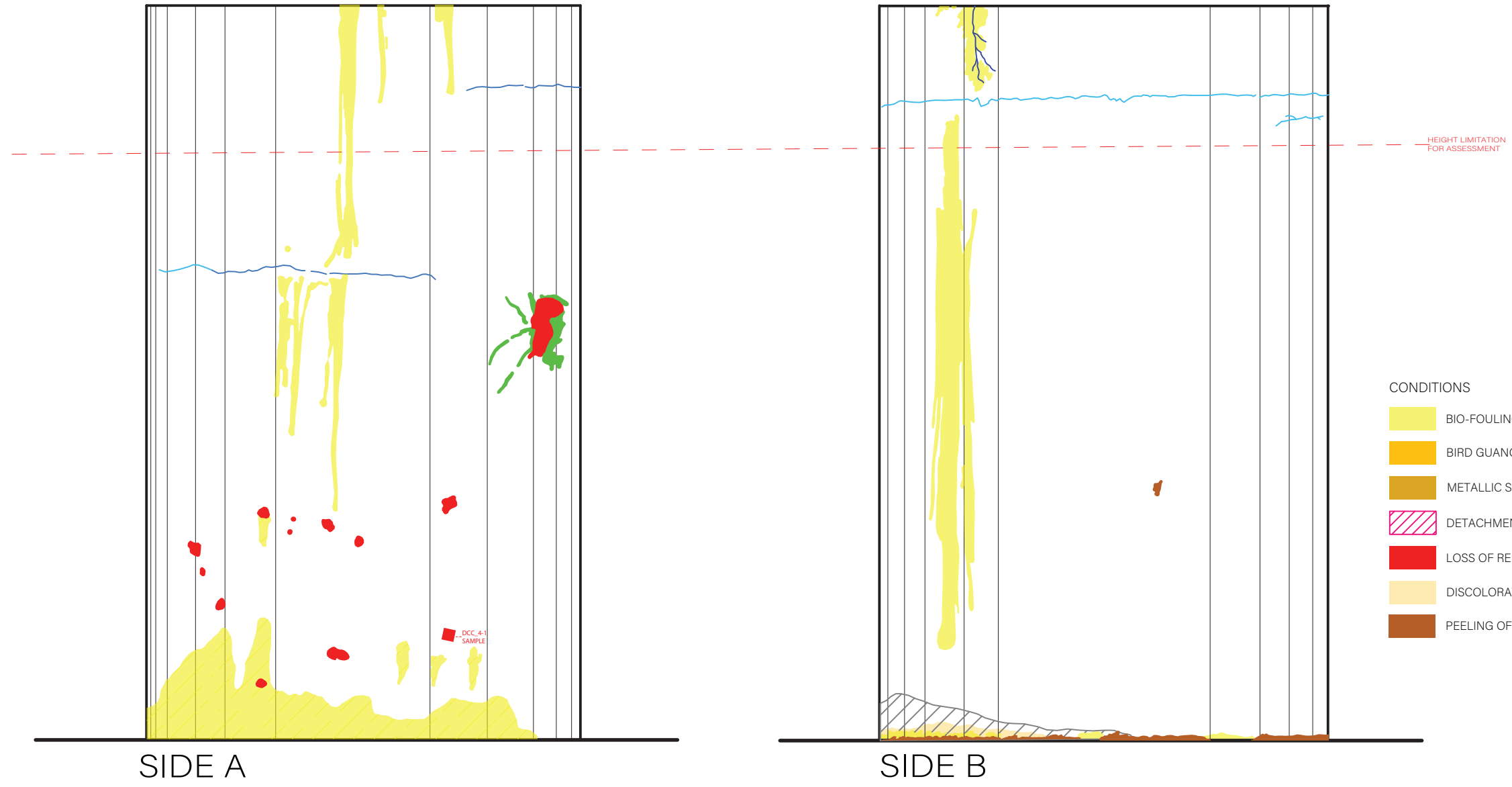
MATERIALS - FINISH & SUBSTRATE: WALL - REINFORCED CONCRETE BLOCKS  
PORTLAND CEMENT STUCCO ON WALL



2 - ENTRANCE WALL ON NORTHWEST ELEVATION

SCALE 1'-0" = 3/8"

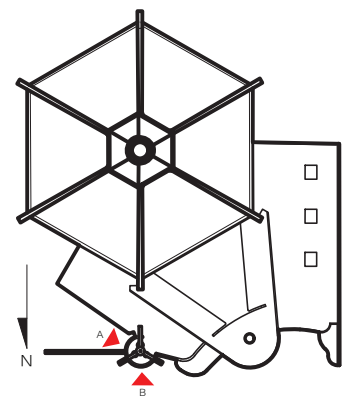




CONDITIONS

- |  |                      |  |                    |
|--|----------------------|--|--------------------|
|  | BIO-FOULING          |  | HAIRLINE CRACK     |
|  | BIRD GUANO           |  | SLIGHT CRACK       |
|  | METALLIC STAINING    |  | LARGE CRACK        |
|  | DETACHMENT/DEBONDING |  | MACROFLORA         |
|  | LOSS OF RENDER       |  | PREVIOUS REPAIR    |
|  | DISCOLORATION        |  | RISING DAMP DAMAGE |
|  | PEELING OF PAINTING  |  | ROOF COATING       |

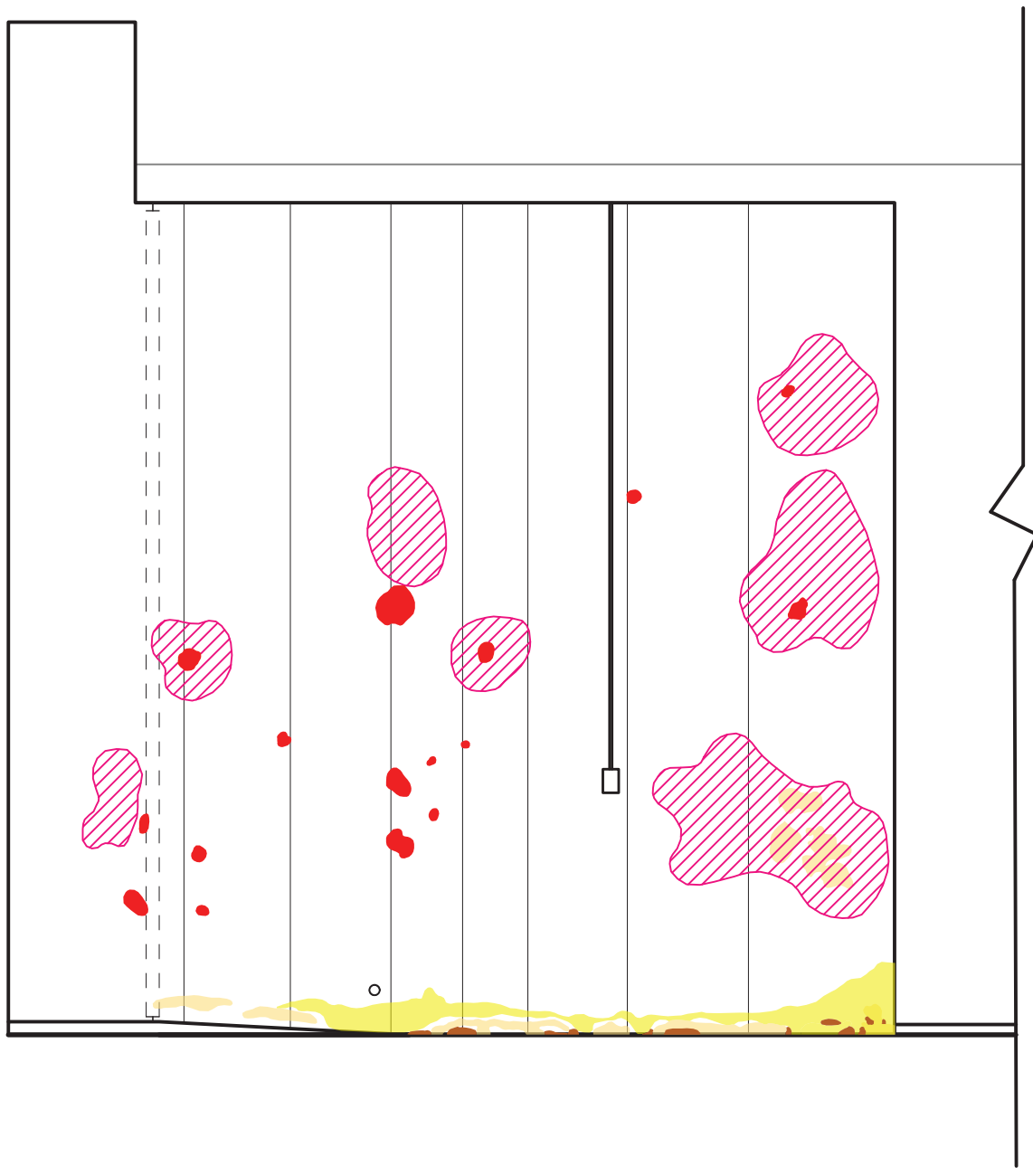
MATERIALS - FINISH & SUBSTRATE: WALL - REINFORCED CONCRETE BLOCKS  
PORTLAND CEMENT STUCCO ON WALL

















3 - BAPTISTRY - CIRCULAR WALL ON NORTHWEST ELEVATION

SCALE 1'-0" = 3/8"

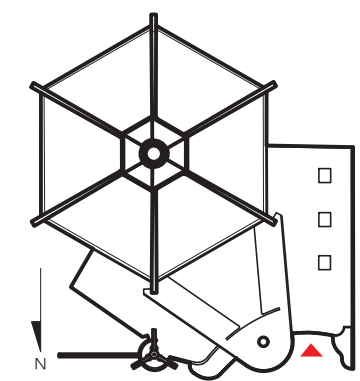




CONDITIONS

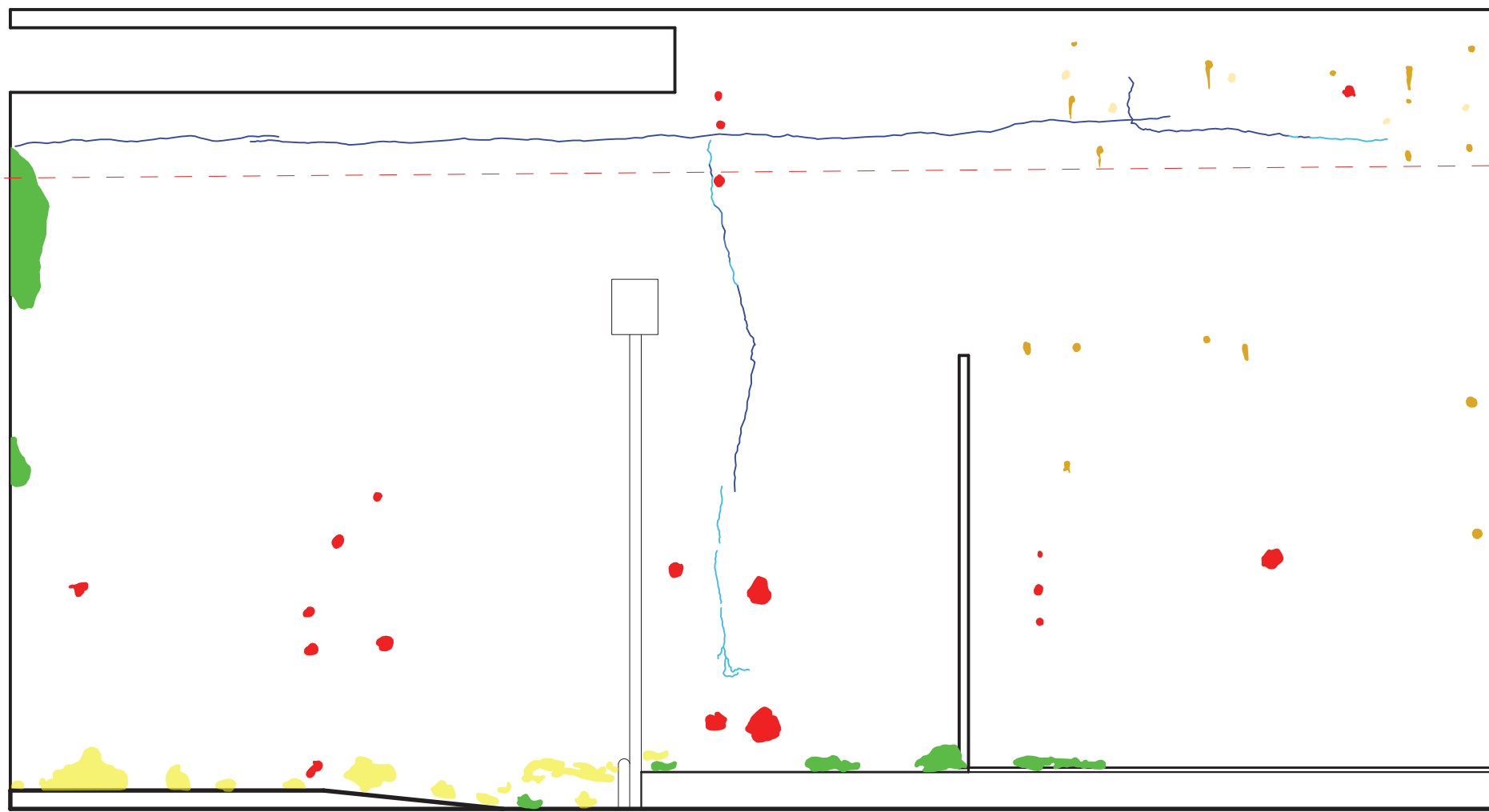
- |  |  |
|--|--|
|  BIO-FOULING          |  HAIRLINE CRACK     |
|  BIRD GUANO           |  SLIGHT CRACK       |
|  METALLIC STAINING    |  LARGE CRACK        |
|  DETACHMENT/DEBONDING |  MACROFLORA         |
|  LOSS OF RENDER       |  PREVIOUS REPAIR    |
|  DISCOLORATION        |  RISING DAMP DAMAGE |
|  PEELING OF PAINTING  |  ROOF COATING       |

MATERIALS - FINISH & SUBSTRATE: WALL - REINFORCED CONCRETE BLOCKS  
PORTLAND CEMENT STUCCO ON WALL



4 - ENTRANCE WALL ON NORTHWEST ELEVATION  
SCALE 1'-0" = 3/8"

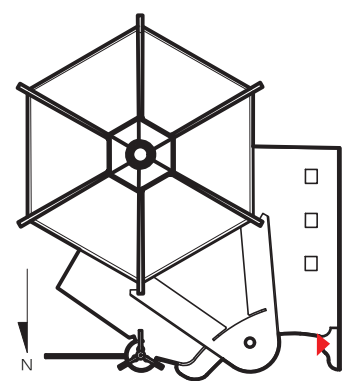




HEIGHT LIMITATION  
FOR ASSESSMENT

CONDITIONS

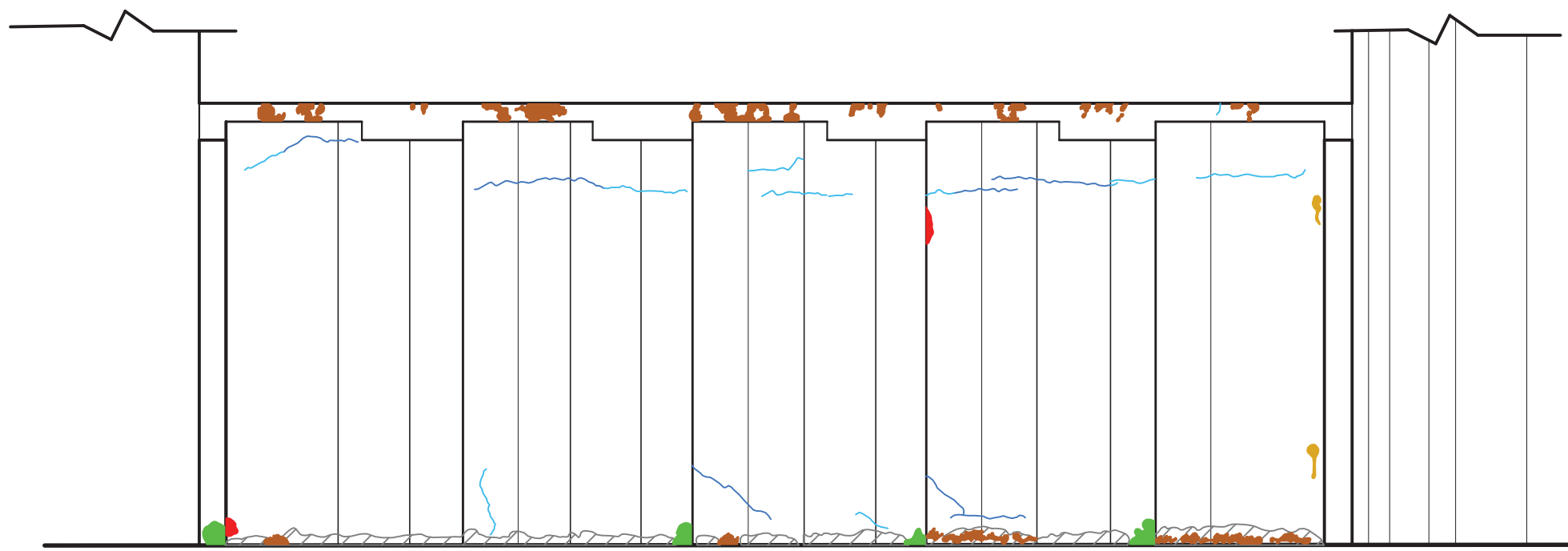
- |                      |                    |
|----------------------|--------------------|
| BIO-FOULING          | HAIRLINE CRACK     |
| BIRD GUANO           | SLIGHT CRACK       |
| METALLIC STAINING    | LARGE CRACK        |
| DETACHMENT/DEBONDING | MACROFLORA         |
| LOSS OF RENDER       | PREVIOUS REPAIR    |
| DISCOLORATION        | RISING DAMP DAMAGE |
| PEELING OF PAINTING  | ROOF COATING       |



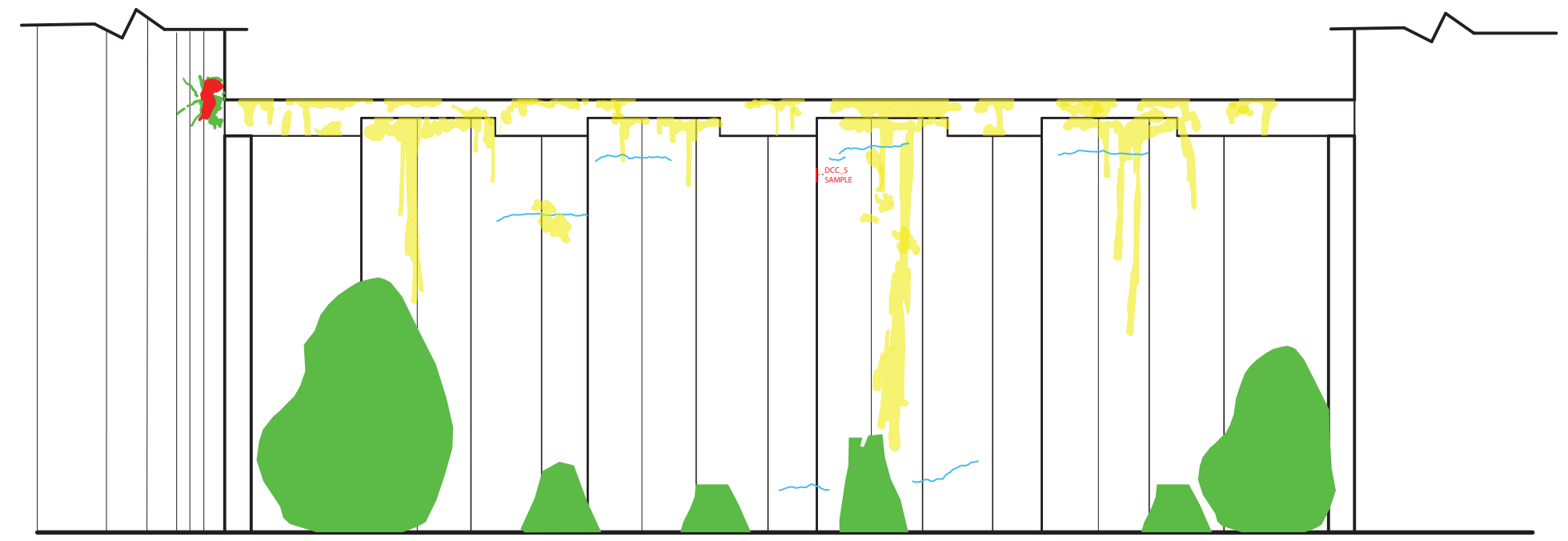
5 - ENTRANCE - EXTERIOR WEST WALL  
SCALE 1'-0" = 3/8"



MATERIALS - FINISH & SUBSTRATE: WALL - REINFORCED CONCRETE BLOCKS  
PORTLAND CEMENT STUCCO ON WALL



SIDE A



SIDE B

6 - EXTERIOR PRECAST WALL ON NORTHEAST ELEVATION

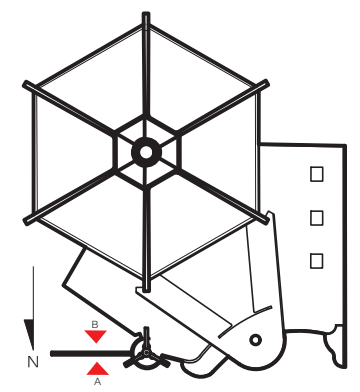
SCALE 1'-0" = 3/8"



CONDITIONS

- |                      |                    |
|----------------------|--------------------|
| BIO-FOULING          | HAIRLINE CRACK     |
| BIRD GUANO           | SLIGHT CRACK       |
| METALLIC STAINING    | LARGE CRACK        |
| DETACHMENT/DEBONDING | MACROFLORA         |
| LOSS OF RENDER       | PREVIOUS REPAIR    |
| DISCOLORATION        | RISING DAMP DAMAGE |
| PEELING OF PAINTING  | ROOF COATING       |

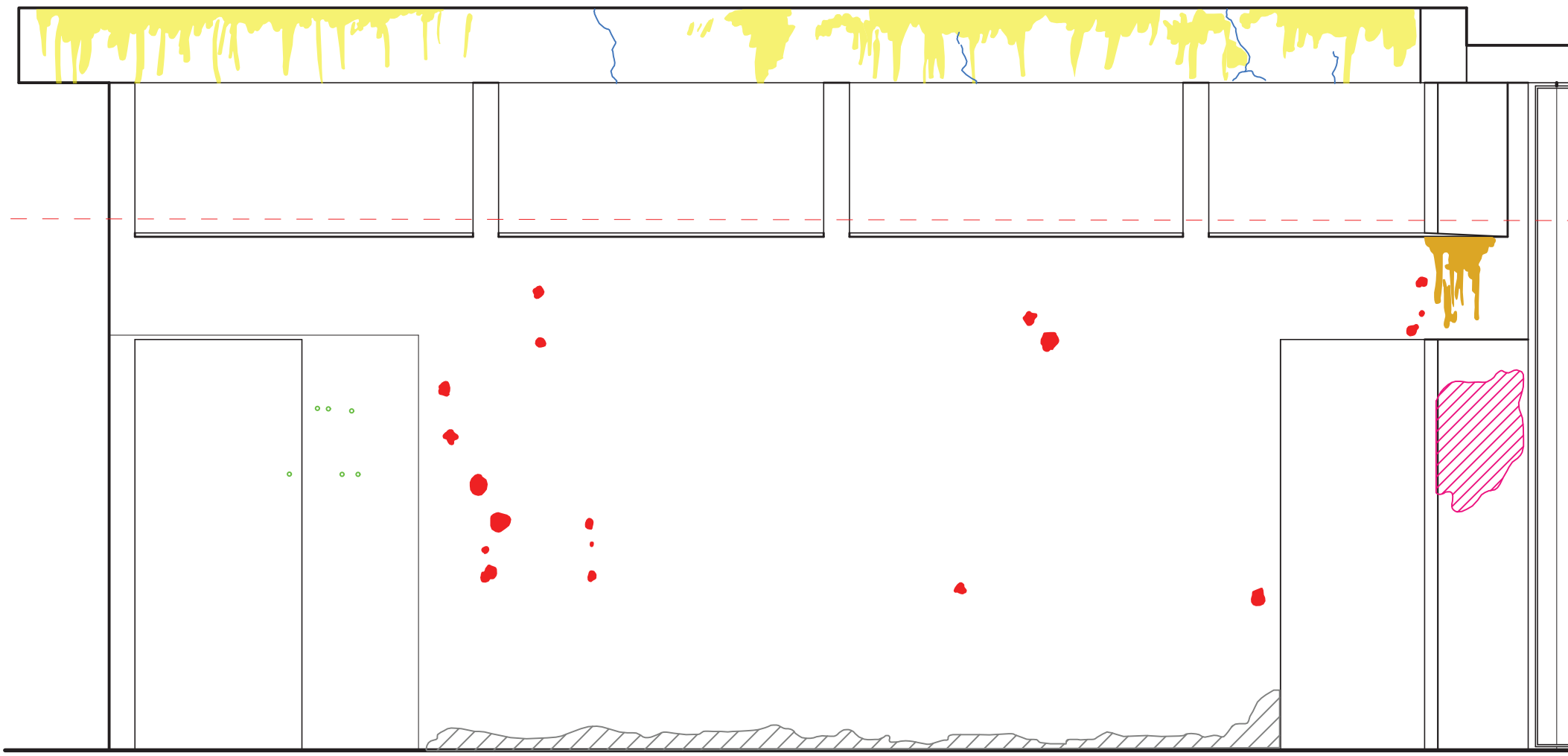
MATERIALS - FINISH & SUBSTRATE: PRECAST CONCRETE PANELS



DRAWN BY: HECTOR J. BERDECIA-HERNANDEZ  
UNIVERSITY OF PENNSYLVANIA  
GRADUATE PROGRAM IN HISTORIC PRESERVATION, SCHOOL OF DESIGN

PARROQUIA NUESTRA SEÑORA DEL CARMEN  
42, CALLE EL TREN, CATAÑO, P.R., 00962

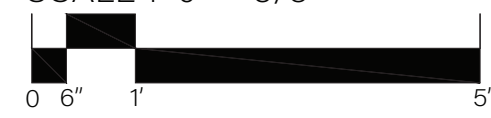
CONDITIONS ASSESSMENT  
SHEET 6 OF 26 SHEETS  
DATE JUN 1, 2020



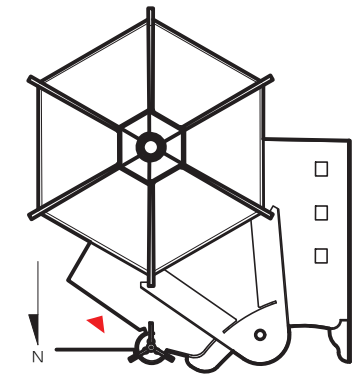
CONDITIONS

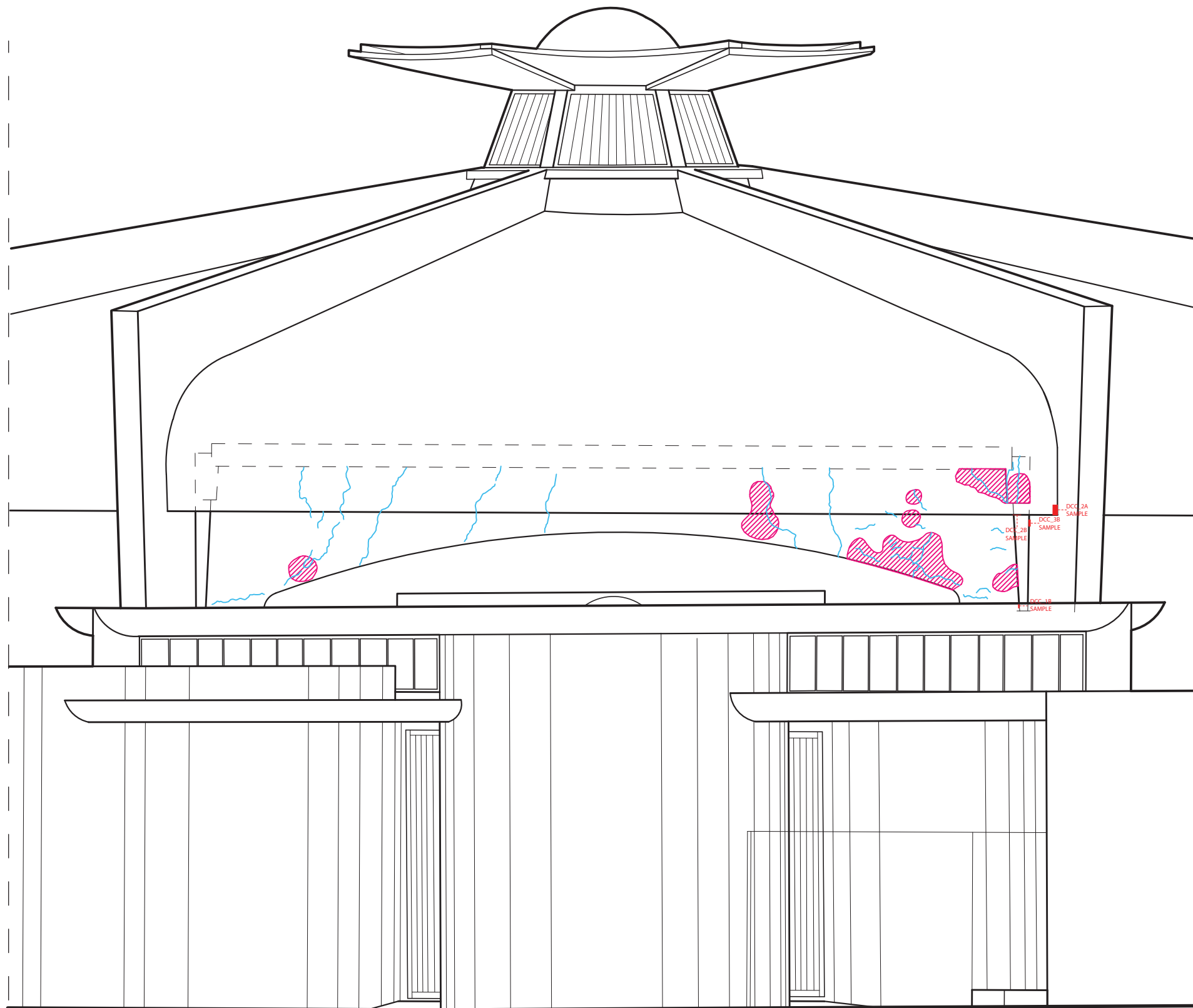
	BIO-FOULING		HAIRLINE CRACK
	BIRD GUANO		SLIGHT CRACK
	METALLIC STAINING		LARGE CRACK
	DETACHMENT/DEBONDING		MACROFLORA
	LOSS OF RENDER		PREVIOUS REPAIR
	DISCOLORATION		RISING DAMP DAMAGE
	PEELING OF PAINTING		ROOF COATING

7 - GARDEN WALL ON NORTHEAST ELEVATION  
SCALE 1'-0" = 3/8"



MATERIALS - FINISH & SUBSTRATE: WALL - REINFORCED CONCRETE BLOCKS  
PORTLAND CEMENT STUCCO ON WALL





8A - NORTHWEST ELEVATION

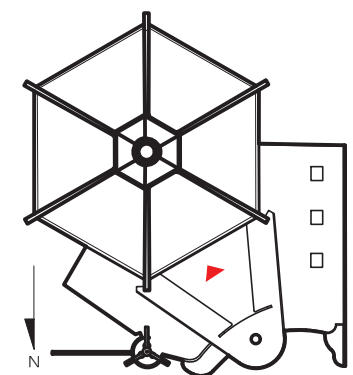
SCALE 1'-0" = 3/16"



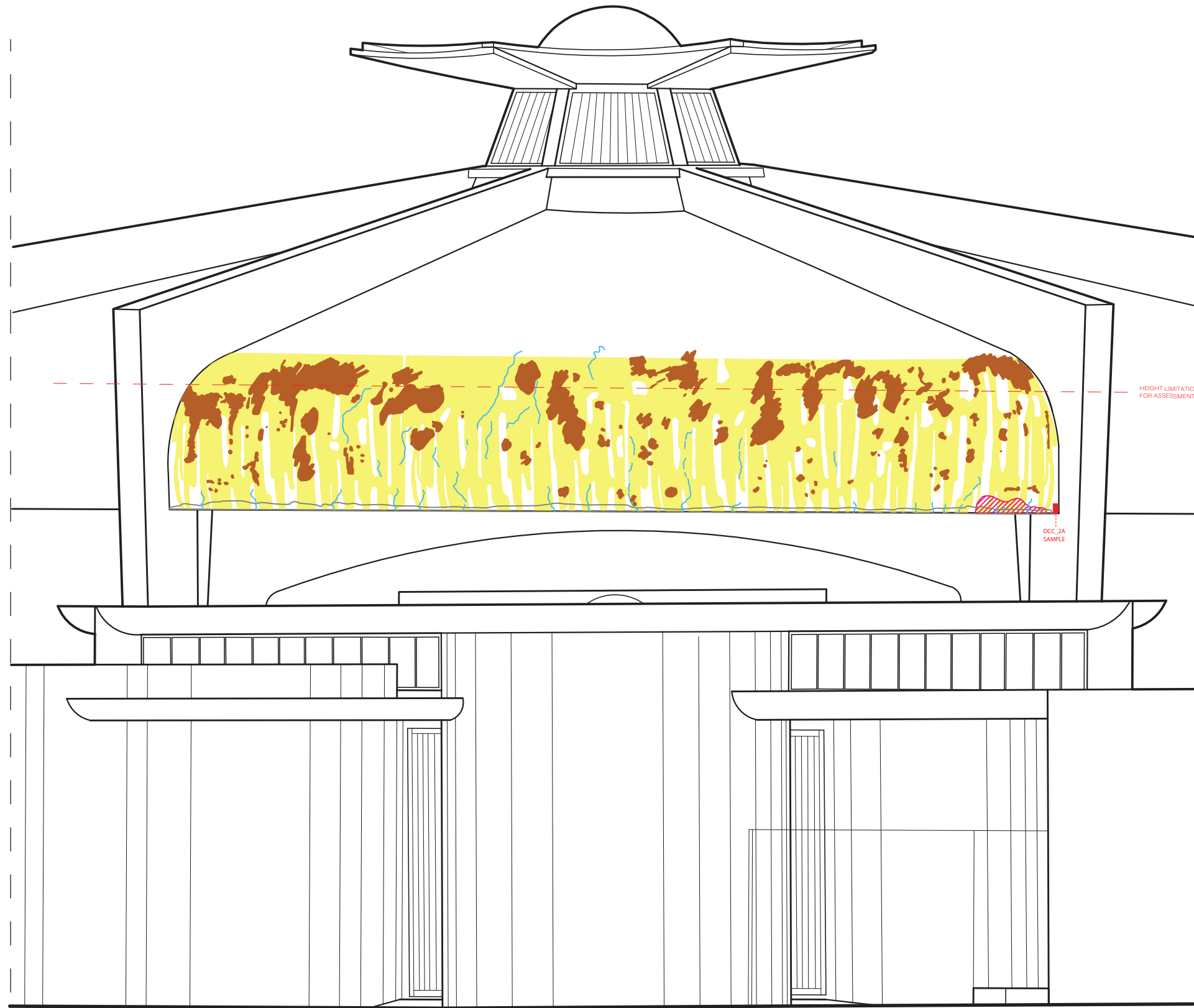
MATERIALS - FINISH & SUBSTRATE: WALL - CAST-IN-PLACE  
PORTLAND CEMENT STUCCO ON WALL

CONDITIONS















- |  |                      |  |                    |
|--|----------------------|--|--------------------|
|  | BIO-FOULING          |  | HAIRLINE CRACK     |
|  | BIRD GUANO           |  | SLIGHT CRACK       |
|  | METALLIC STAINING    |  | LARGE CRACK        |
|  | DETACHMENT/DEBONDING |  | MACROFLORA         |
|  | LOSS OF RENDER       |  | PREVIOUS REPAIR    |
|  | DISCOLORATION        |  | RISING DAMP DAMAGE |
|  | PEELING OF PAINTING  |  | ROOF COATING       |



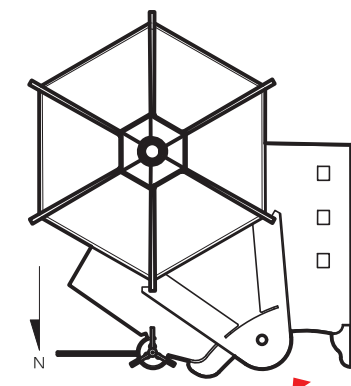




CONDITIONS

- |   |                      |   |                    |
|---|----------------------|---|--------------------|
|  | BIO-FOULING          |  | HAIRLINE CRACK     |
|  | BIRD GUANO           |  | SLIGHT CRACK       |
|  | METALLIC STAINING    |  | LARGE CRACK        |
|  | DETACHMENT/DEBONDING |  | MACROFLORA         |
|  | LOSS OF RENDER       |  | PREVIOUS REPAIR    |
|  | DISCOLORATION        |  | RISING DAMP DAMAGE |
|  | PEELING OF PAINTING  |  | ROOF COATING       |

MATERIALS - FINISH & SUBSTRATE: DOME - CAST-IN-PLACE CONCRETE  
PORTLAND CEMENT STUCCO

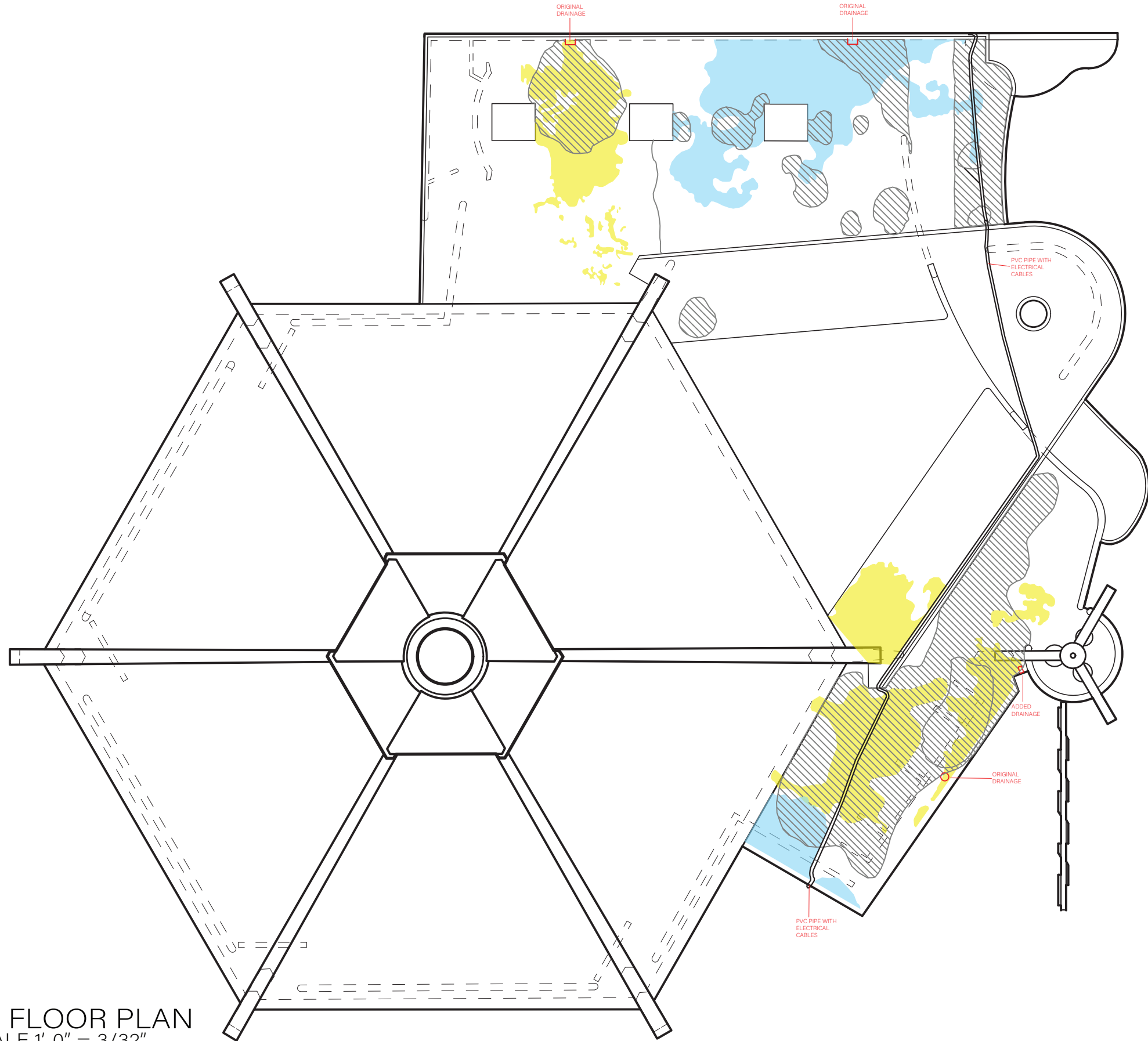


8B - NORTHWEST ELEVATION

SCALE 1'-0" = 3/16"

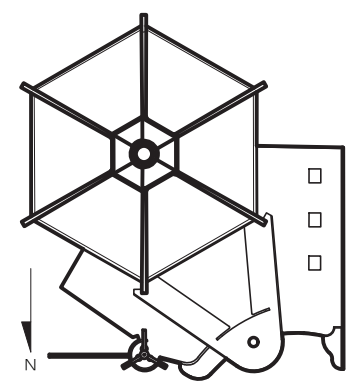


9 - FLOOR PLAN  
SCALE 1'-0" = 3/32"



CONDITIONS

- STAINING
- WATER PONDING
- TEMPORARY WATER PONDING



DRAWN BY: HECTOR J. BERDECIA-HERNANDEZ

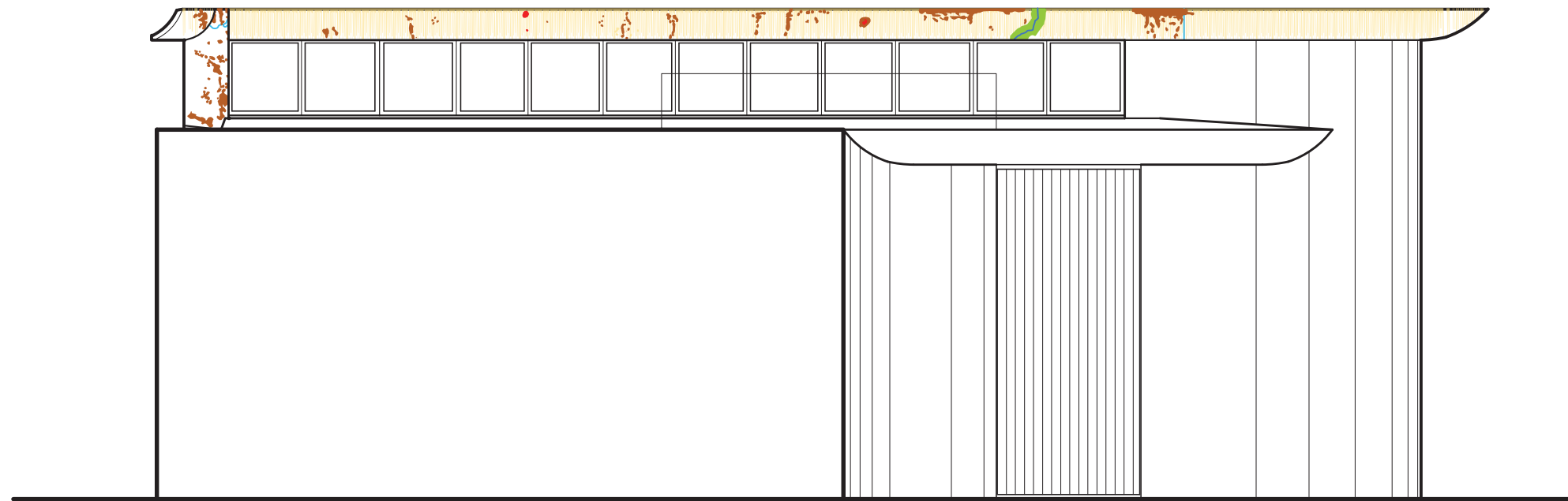
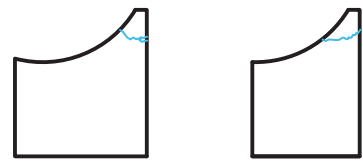
UNIVERSITY OF PENNSYLVANIA  
GRADUATE PROGRAM IN HISTORIC PRESERVATION, SCHOOL OF DESIGN

PARROQUIA NUESTRA SEÑORA DEL CARMEN  
42 CALLE EL TREN, CATAÑO, P.R., 00982















CONDITIONS ASSESSMENT  
SHEET 10 OF 26 SHEETS

DATE  
JUN 1, 2020

IF REPRODUCED, PLEASE CREDIT THE GRADUATE PROGRAM IN HISTORIC PRESERVATION, UNIVERSITY OF PENNSYLVANIA, NAME OF DELINEATOR, DATE OF DRAWING



CONDITIONS

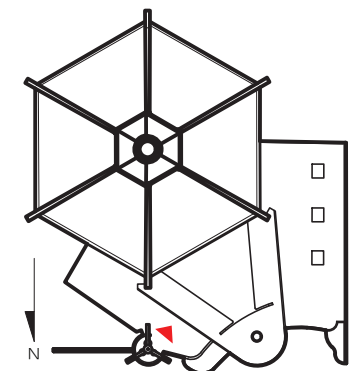
- |  |  |
|--|--|
|  BIO-FOULING          |  HAIRLINE CRACK     |
|  BIRD GUANO           |  SLIGHT CRACK       |
|  METALLIC STAINING    |  LARGE CRACK        |
|  DETACHMENT/DEBONDING |  MACROFLORA         |
|  LOSS OF RENDER       |  PREVIOUS REPAIR    |
|  DISCOLORATION        |  RISING DAMP DAMAGE |
|  PEELING OF PAINTING  |  ROOF COATING       |

10A - CLERESTORY WINDOWS - EAST SIDE

SCALE 1'-0" = 3/16"



MATERIALS - FINISH & SUBSTRATE: EAVES - CAST-IN-PLACE CONCRETE



DRAWN BY: HECTOR J. BERDECIA-HERNANDEZ

UNIVERSITY OF PENNSYLVANIA  
GRADUATE PROGRAM IN HISTORIC PRESERVATION, SCHOOL OF DESIGN

PARROQUIA NUESTRA SEÑORA DEL CARMEN  
42 CALLE EL TREN, CATAÑO, P.R., 00982















CONDITIONS ASSESSMENT  
SHEET 11 OF 26 SHEETS

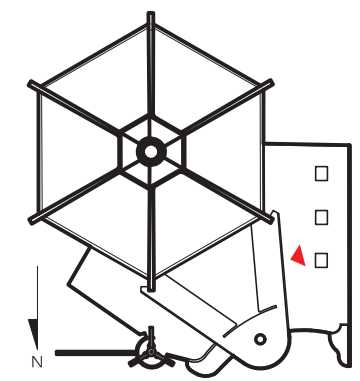
DATE  
JUN 1, 2020

#REPRODUCED: PLEASE CREDIT THE GRADUATE PROGRAM IN HISTORIC PRESERVATION, UNIVERSITY OF PENNSYLVANIA, NAME OF DELIVERABLE, DATE OF DRAWING



CONDITIONS

- |  |  |
|--|--|
|  BIO-FOULING          |  HAIRLINE CRACK     |
|  BIRD GUANO           |  SLIGHT CRACK       |
|  METALLIC STAINING    |  LARGE CRACK        |
|  DETACHMENT/DEBONDING |  MACROFLORA         |
|  LOSS OF RENDER       |  PREVIOUS REPAIR    |
|  DISCOLORATION        |  RISING DAMP DAMAGE |
|  PEELING OF PAINTING  |  ROOF COATING       |



10B - CLERESTORY WINDOWS - WEST SIDE

SCALE 1'-0" = 3/16"



MATERIALS - FINISH & SUBSTRATE: EAVES - CAST-IN-PLACE CONCRETE

DRAWN BY: HECTOR J. BERDECIA-HERNANDEZ

UNIVERSITY OF PENNSYLVANIA  
GRADUATE PROGRAM IN HISTORIC PRESERVATION, SCHOOL OF DESIGN

PARROQUIA NUESTRA SEÑORA DEL CARMEN  
42 CALLE EL TREN, CATAÑO, P.R., 00982

CONDITIONS  
ASSESSMENT  
SHEET 12 OF 26 SHEETS

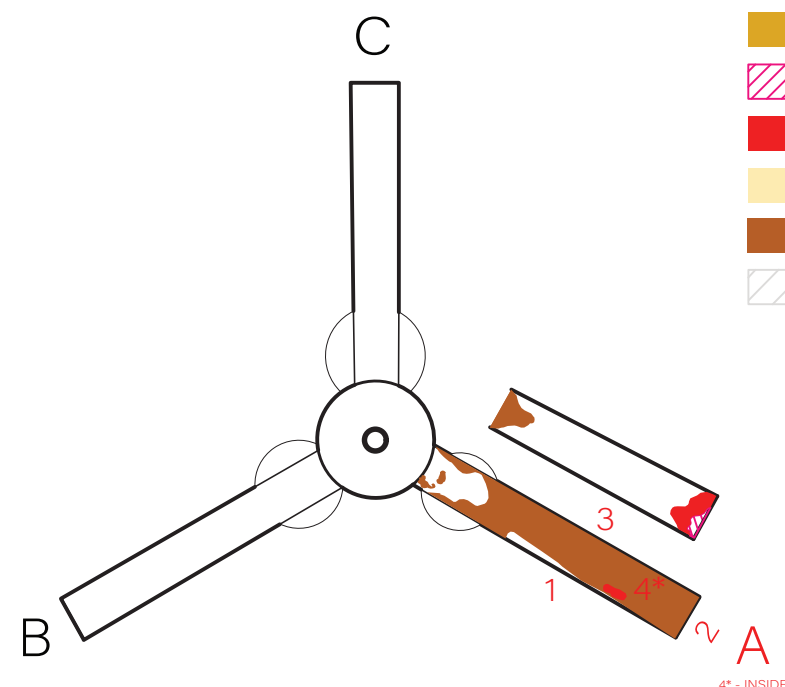
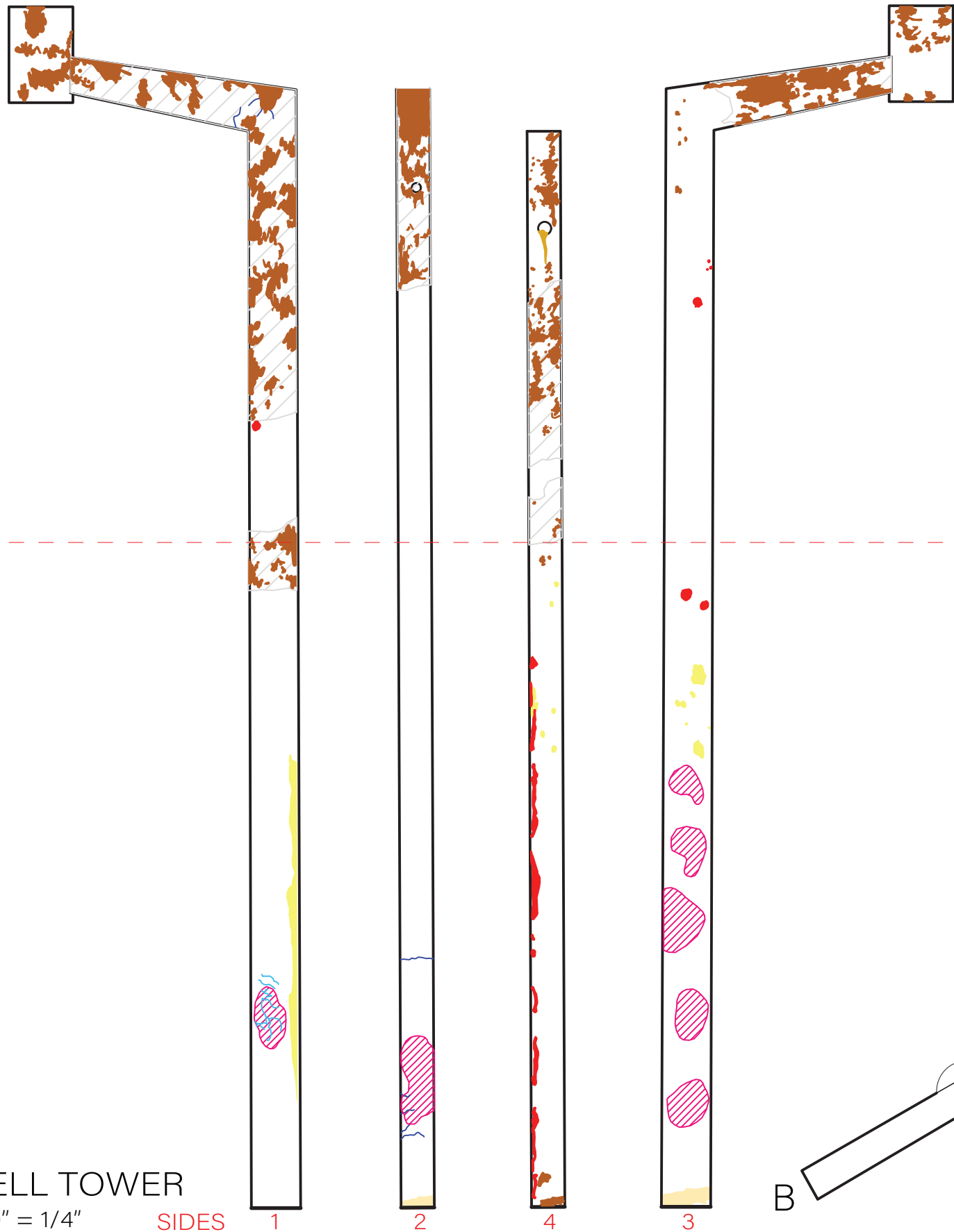
DATE  
JUNE 1, 2020

IF REPRODUCED, PLEASE CREDIT THE HISTORIC AMERICAN BUILDINGS SURVEY, NATIONAL PARK SERVICE, NAME OF DELINEATOR, DATE OF DRAWING

# 11A - BELL TOWER

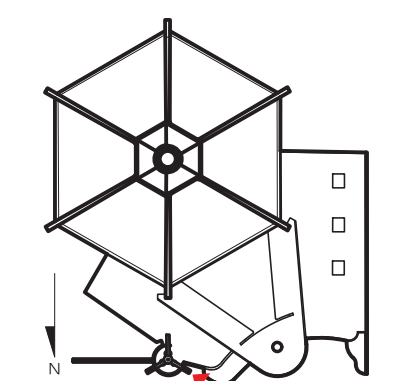
SCALE 1'-0" = 1/4"

SIDES

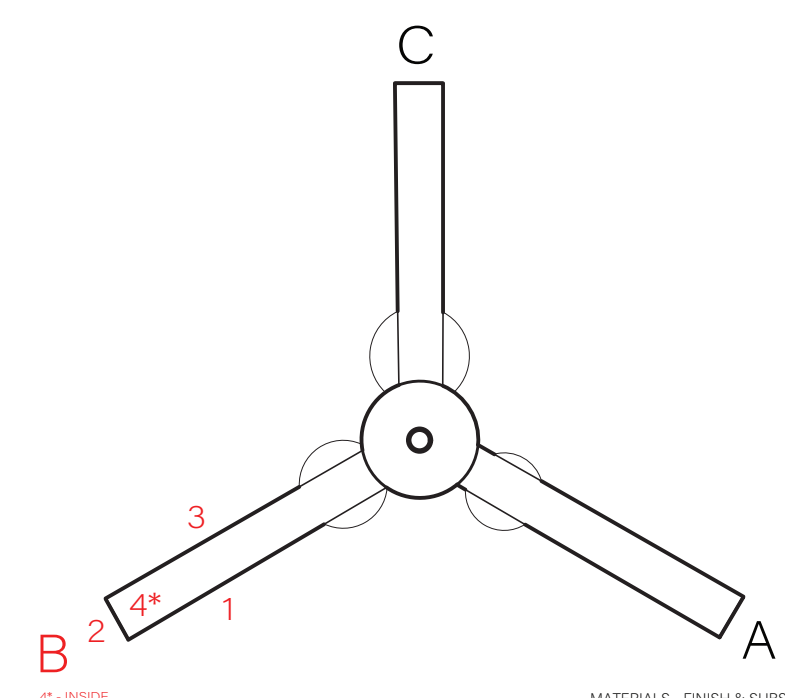
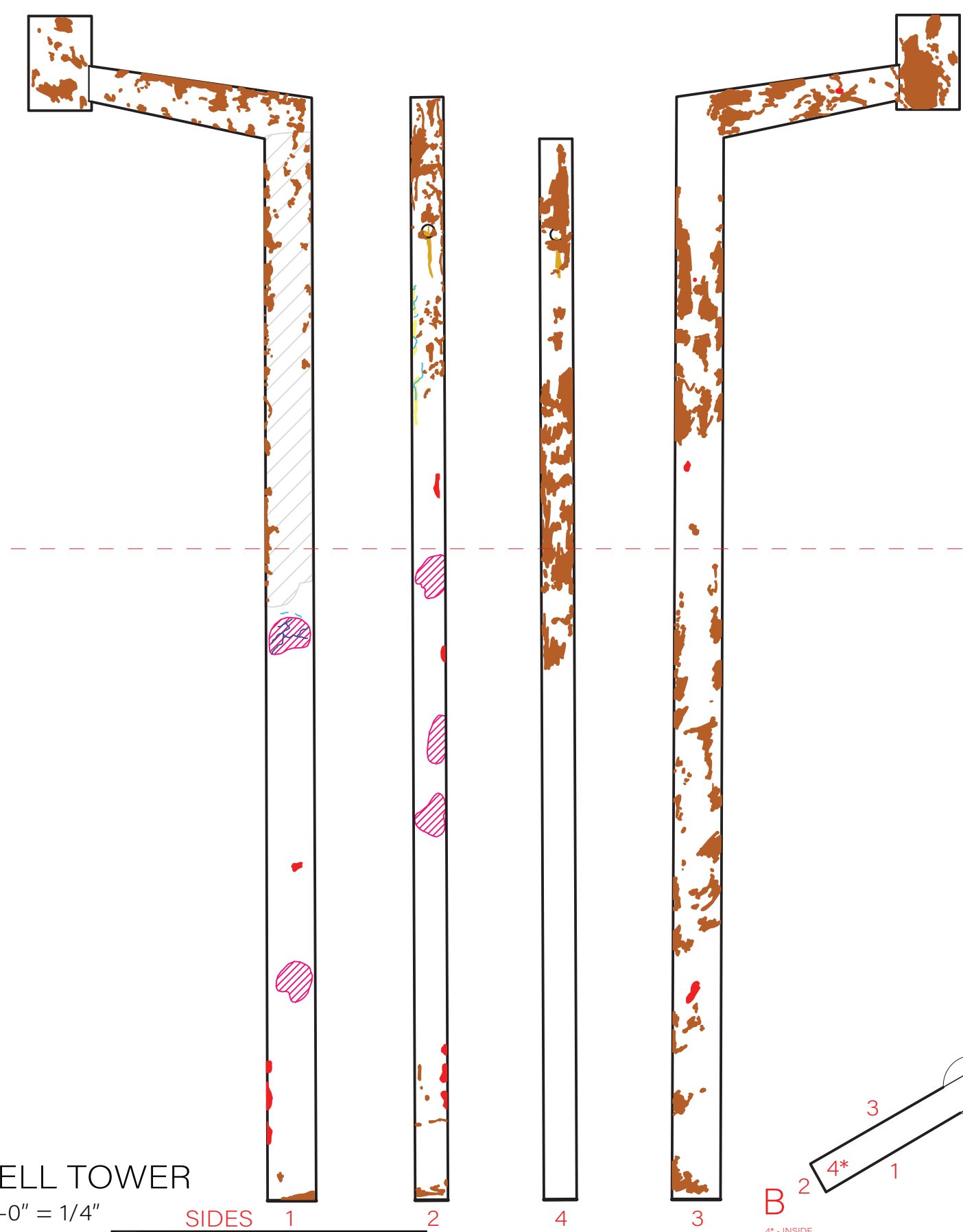


MATERIALS - FINISH & SUBSTRATE: REINFORCED CONCRETE BLOCKS  
PORTLAND CEMENT STUCCO

CONDITIONS	
	BIO-FOULING
	BIRD GUANO
	METALLIC STAINING
	DETACHMENT/DEBONDING
	LOSS OF RENDER
	DISCOLORATION
	PEELING OF PAINTING
	PREVIOUS PAINT COATING
	HAIRLINE CRACK
	SLIGHT CRACK
	LARGE CRACK
	MACROFLORA
	PREVIOUS REPAIR
	RISING DAMP DAMAGE
	ROOF COATING

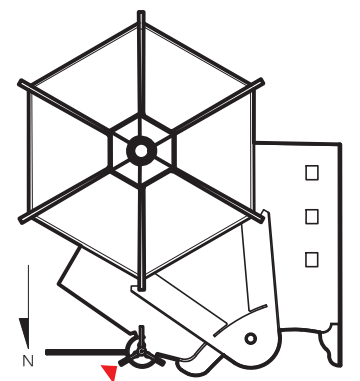


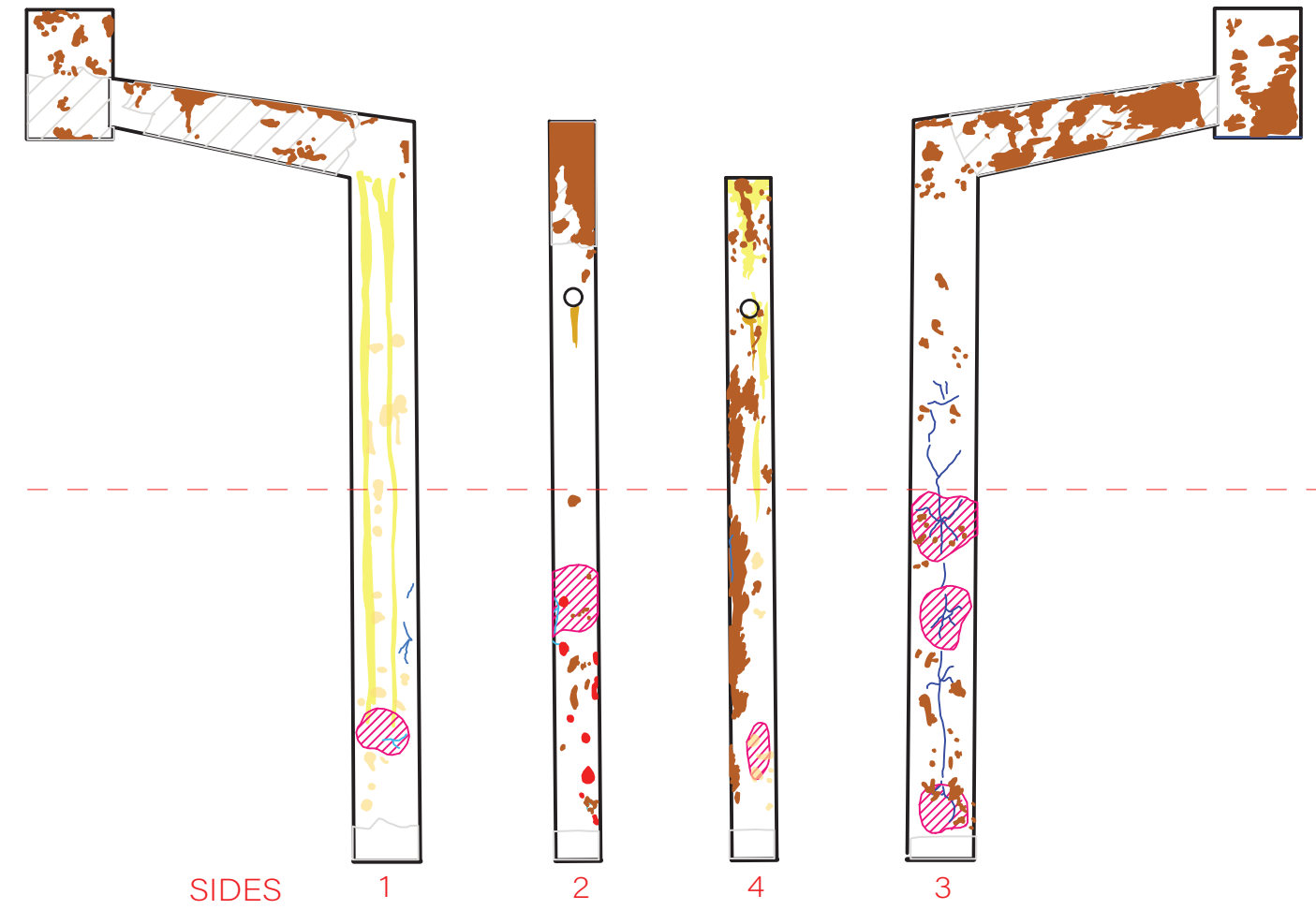
11B- BELL TOWER  
SCALE 1'-0" = 1/4"



MATERIALS - FINISH & SUBSTRATE: REINFORCED CONCRETE BLOCKS  
PORTLAND CEMENT STUCCO

CONDITIONS			
	BIO-FOULING		HAIRLINE CRACK
	BIRD GUANO		SLIGHT CRACK
	METALLIC STAINING		LARGE CRACK
	DETACHMENT/DEBONDING		MACROFLORA
	LOSS OF RENDER		PREVIOUS REPAIR
	DISCOLORATION		RISING DAMP DAMAGE
	PEELING OF PAINTING		ROOF COATING
	PREVIOUS PAINT COATING		





SIDES

1

2

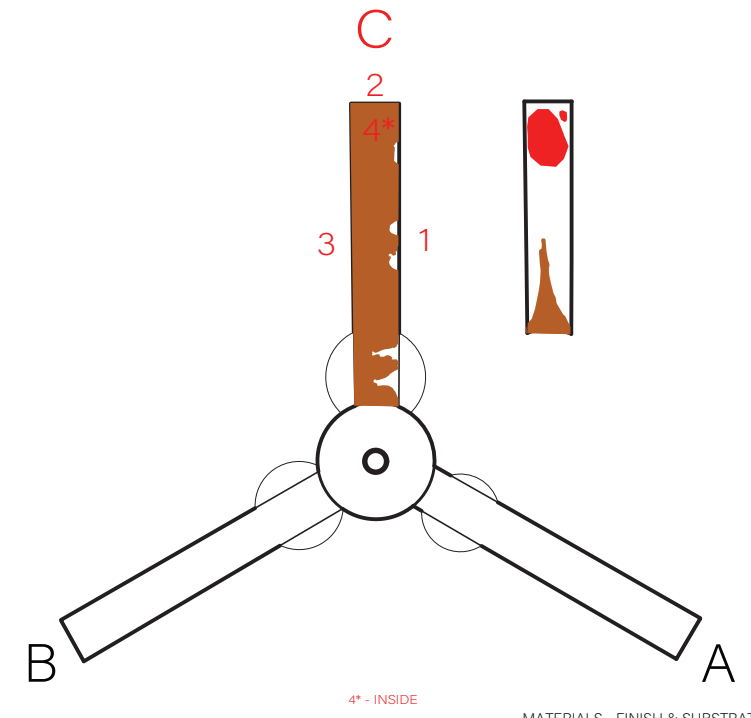
4

3

HEIGHT LIMITATION  
FOR ASSESSMENT

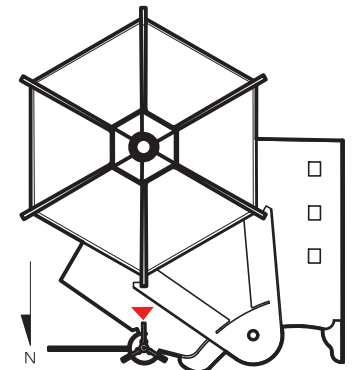
CONDITIONS

- BIO-FOULING
- BIRD GUANO
- METALLIC STAINING
- DETACHMENT/DEBONDING
- LOSS OF RENDER
- DISCOLORATION
- PEELING OF PAINTING
- PREVIOUS PAINT COATING
- HAIRLINE CRACK
- SLIGHT CRACK
- LARGE CRACK
- MACROFLORA
- PREVIOUS REPAIR
- RISING DAMP DAMAGE
- ROOF COATING



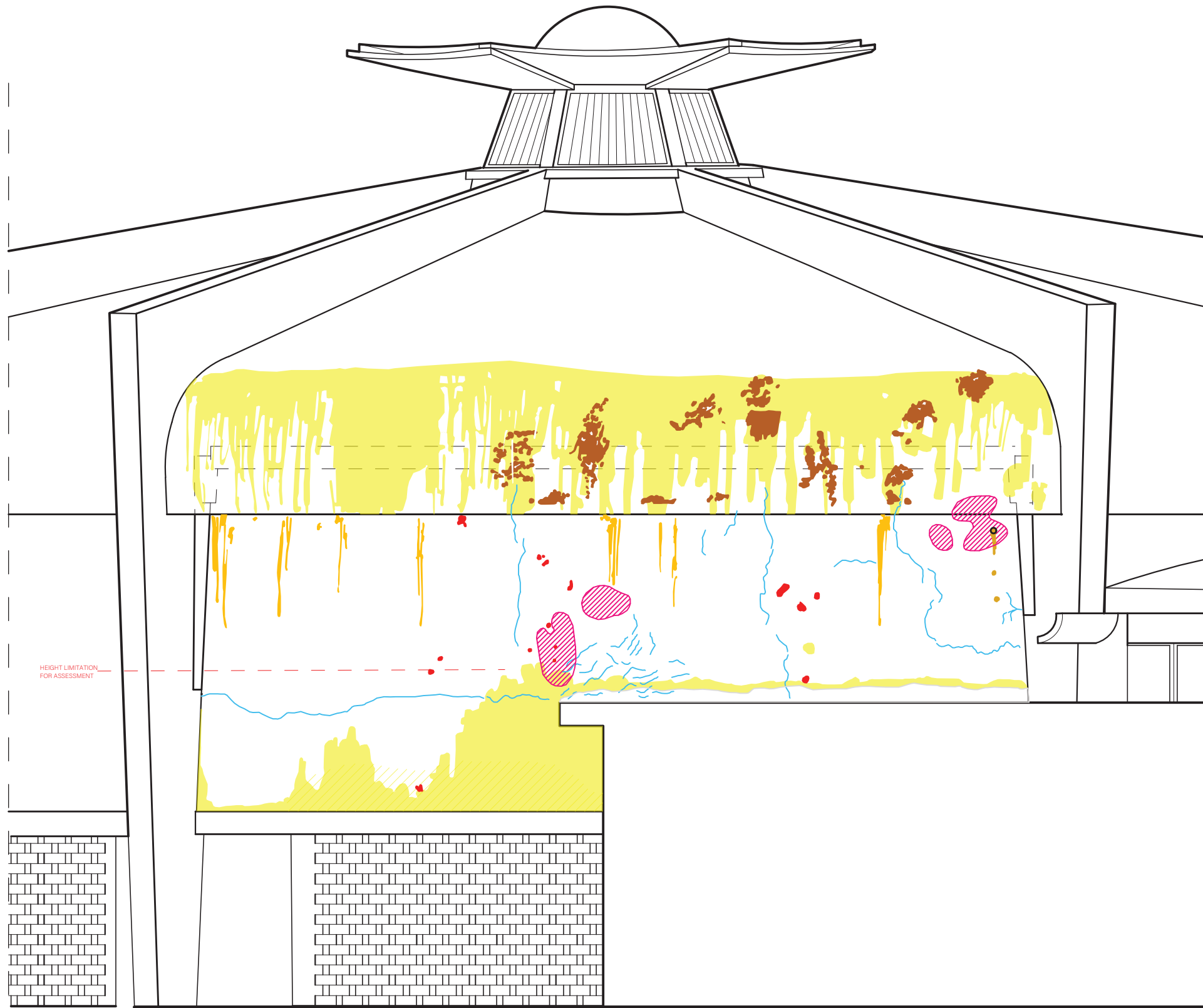
4" - INSIDE

MATERIALS - FINISH & SUBSTRATE: REINFORCED CONCRETE BLOCKS  
PORTLAND CEMENT STUCCO



11C - BELL TOWER  
SCALE 1'-0" = 1/4"





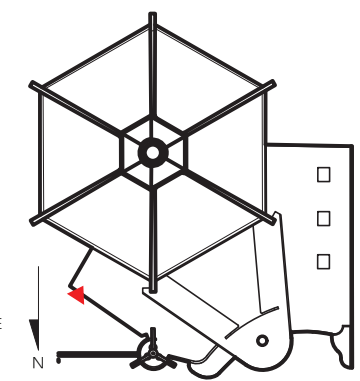
- CONDITIONS
- |  |                      |  |                    |
|--|----------------------|--|--------------------|
|  | BIO-FOULING          |  | HAIRLINE CRACK     |
|  | BIRD GUANO           |  | SLIGHT CRACK       |
|  | METALLIC STAINING    |  | LARGE CRACK        |
|  | DETACHMENT/DEBONDING |  | MACROFLORA         |
|  | LOSS OF RENDER       |  | PREVIOUS REPAIR    |
|  | DISCOLORATION        |  | RISING DAMP DAMAGE |
|  | PEELING OF PAINTING  |  | ROOF COATING       |

12 - NORTHEAST ELEVATION

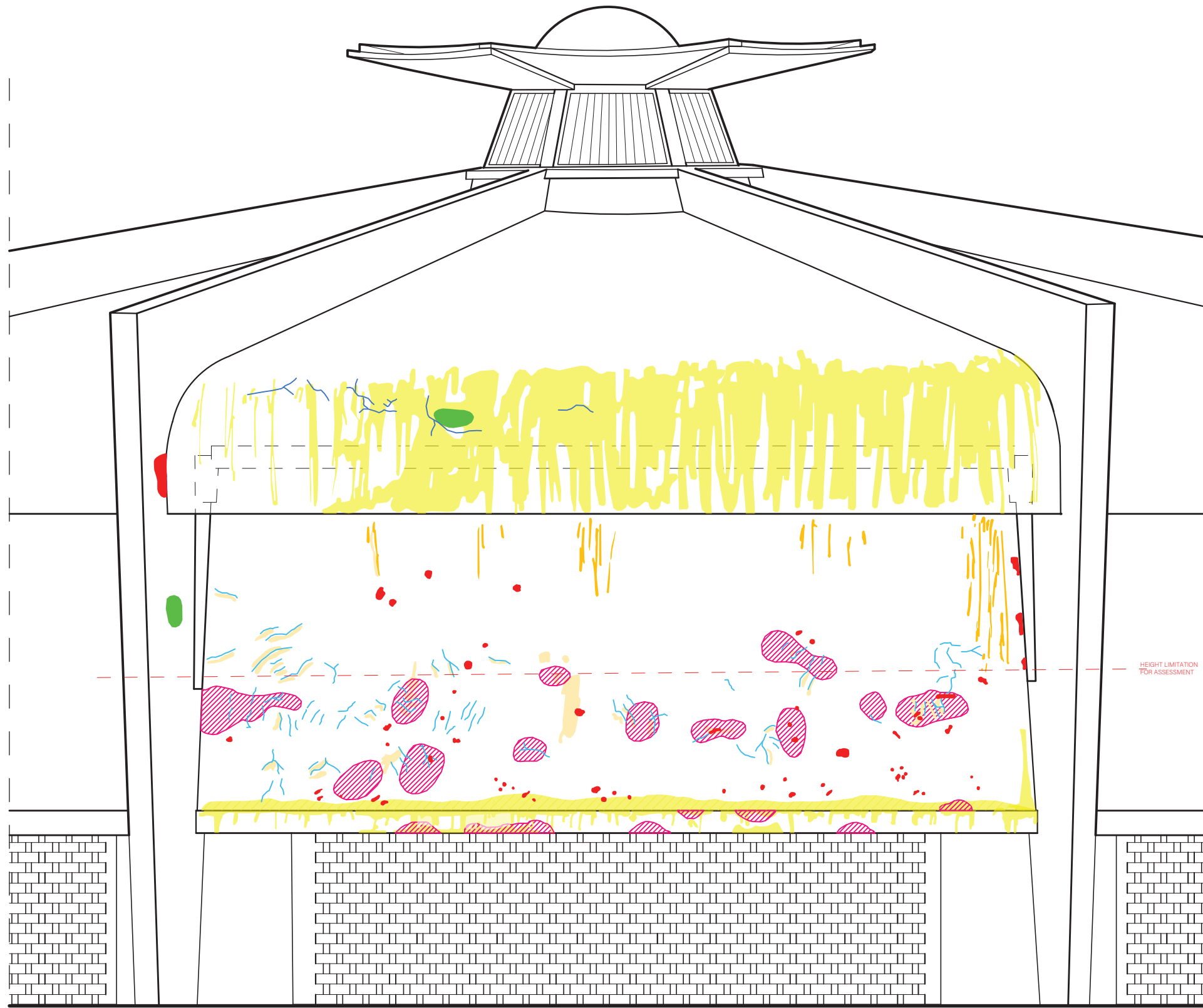
SCALE 1'-0" = 3/16"

















MATERIALS - FINISH & SUBSTRATE: TILTED WALL - CAST-IN-PLACE CONCRETE  
 DOME - CAST-IN-PLACE CONCRETE  
 PORTLAND CEMENT STUCCO





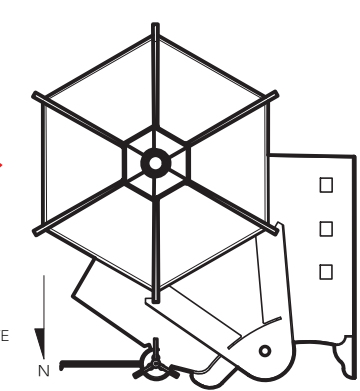



CONDITIONS

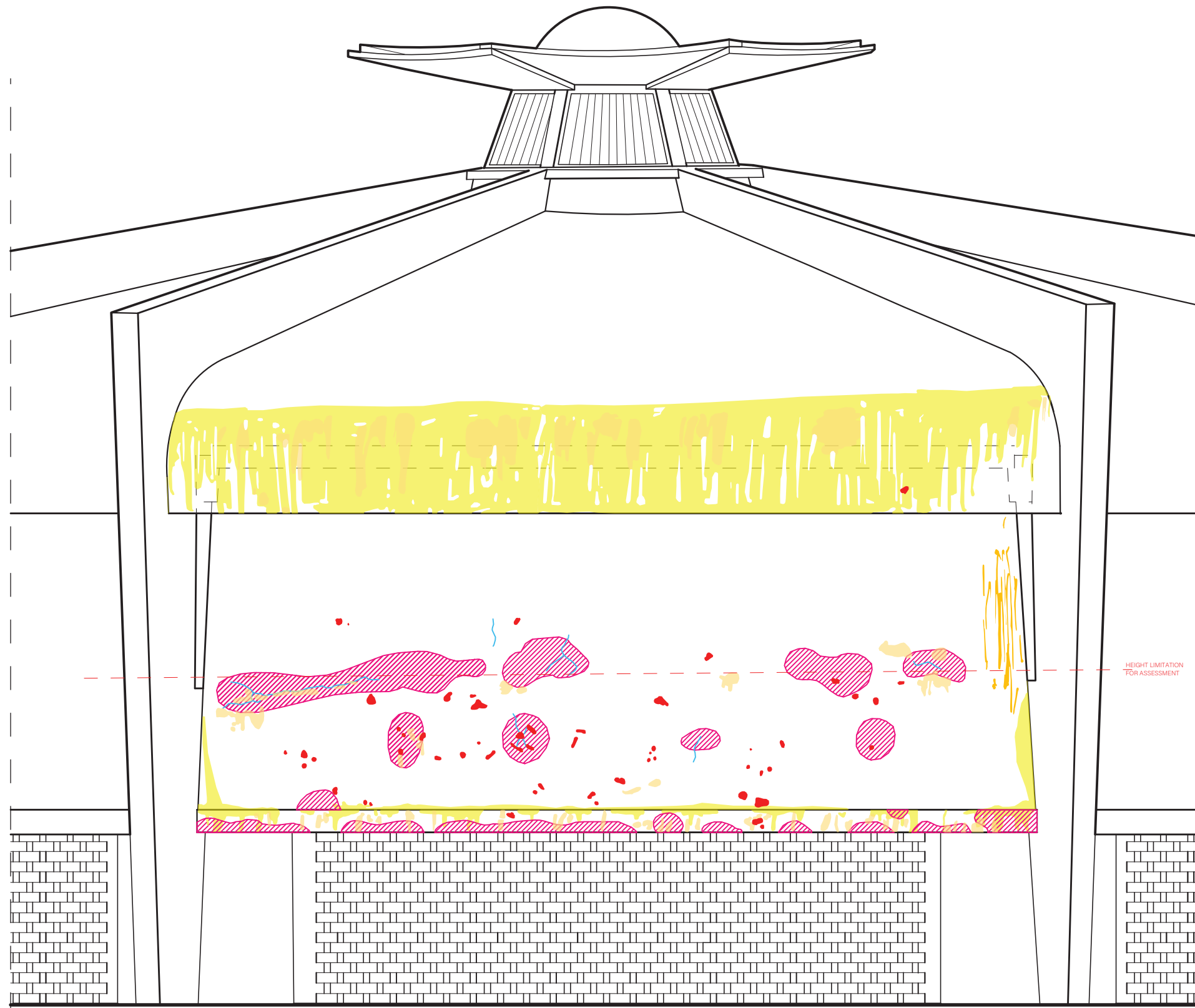
- |  |  |
|--|--|
|  BIO-FOULING          |  HAIRLINE CRACK     |
|  BIRD GUANO           |  SLIGHT CRACK       |
|  METALLIC STAINING    |  LARGE CRACK        |
|  DETACHMENT/DEBONDING |  MACROFLORA         |
|  LOSS OF RENDER       |  PREVIOUS REPAIR    |
|  DISCOLORATION        |  RISING DAMP DAMAGE |
|  PEELING OF PAINTING  |  ROOF COATING       |

HEIGHT LIMITATION FOR ASSESSMENT

MATERIALS - FINISH & SUBSTRATE: TILTED WALL - CAST-IN-PLACE CONCRETE  
 DOME - CAST-IN-PLACE CONCRETE  
 PORTLAND CEMENT STUCCO



13- EAST ELEVATION  
 SCALE 1'-0" = 3/16"  


















14 - SOUTHEAST ELEVATION

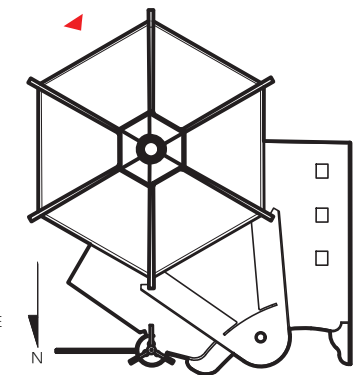
SCALE 1'-0" = 3/16"

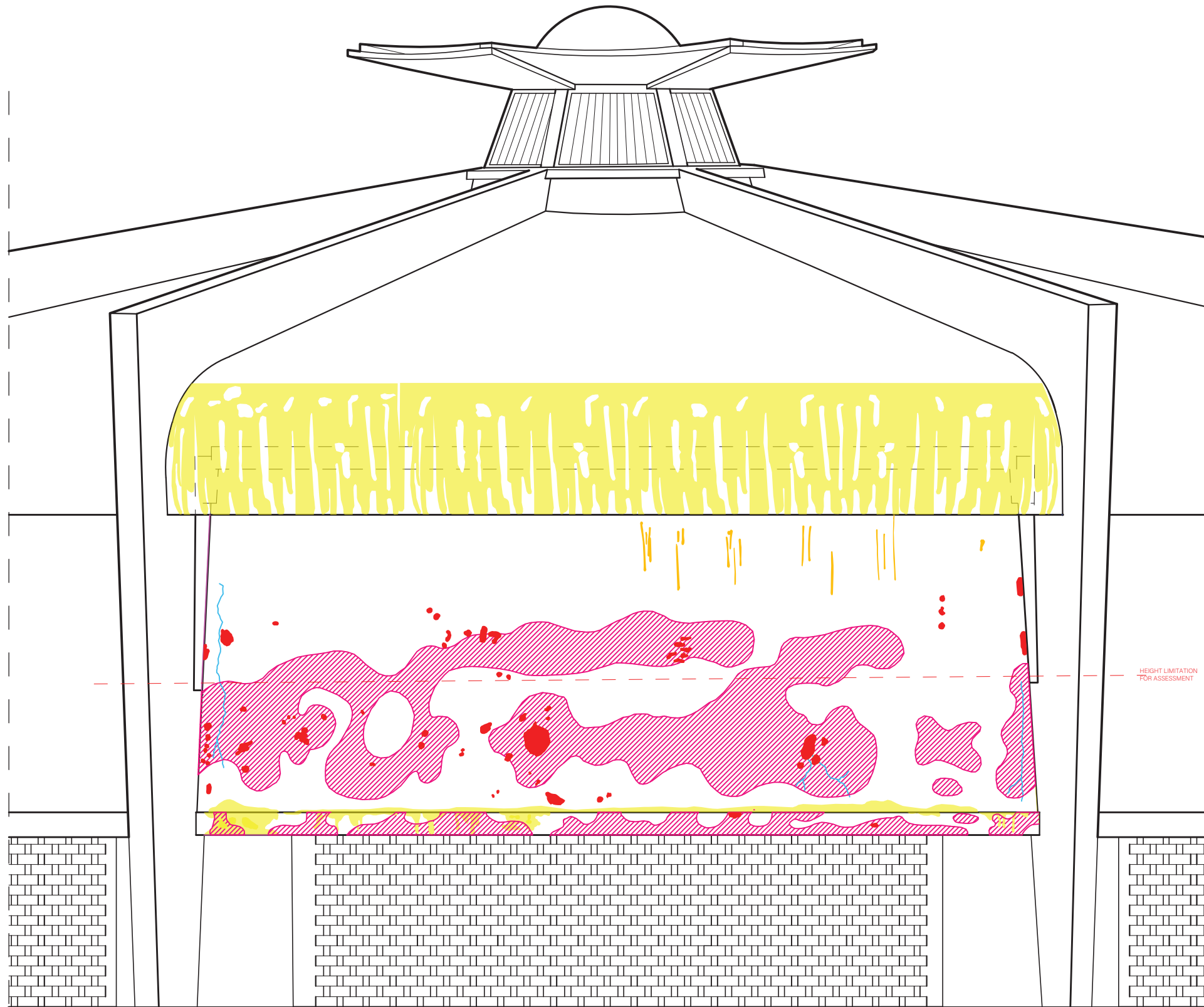


MATERIALS - FINISH & SUBSTRATE: TILTED WALL - CAST-IN-PLACE CONCRETE  
 DOME - CAST-IN-PLACE CONCRETE  
 PORTLAND CEMENT STUCCO















CONDITIONS

- |  |  |
|--|--|
|  BIO-FOULING          |  HAIRLINE CRACK     |
|  BIRD GUANO           |  SLIGHT CRACK       |
|  METALLIC STAINING    |  LARGE CRACK        |
|  DETACHMENT/DEBONDING |  MACROFLORA         |
|  LOSS OF RENDER       |  PREVIOUS REPAIR    |
|  DISCOLORATION        |  RISING DAMP DAMAGE |
|  PEELING OF PAINTING  |  ROOF COATING       |

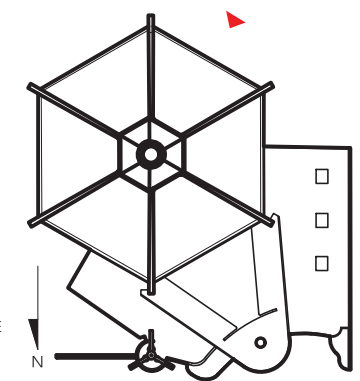




CONDITIONS

- |  |  |
|--|--|
|  BIO-FOULING          |  HAIRLINE CRACK     |
|  BIRD GUANO           |  SLIGHT CRACK       |
|  METALLIC STAINING    |  LARGE CRACK        |
|  DETACHMENT/DEBONDING |  MACROFLORA         |
|  LOSS OF RENDER       |  PREVIOUS REPAIR    |
|  DISCOLORATION        |  RISING DAMP DAMAGE |
|  PEELING OF PAINTING  |  ROOF COATING       |

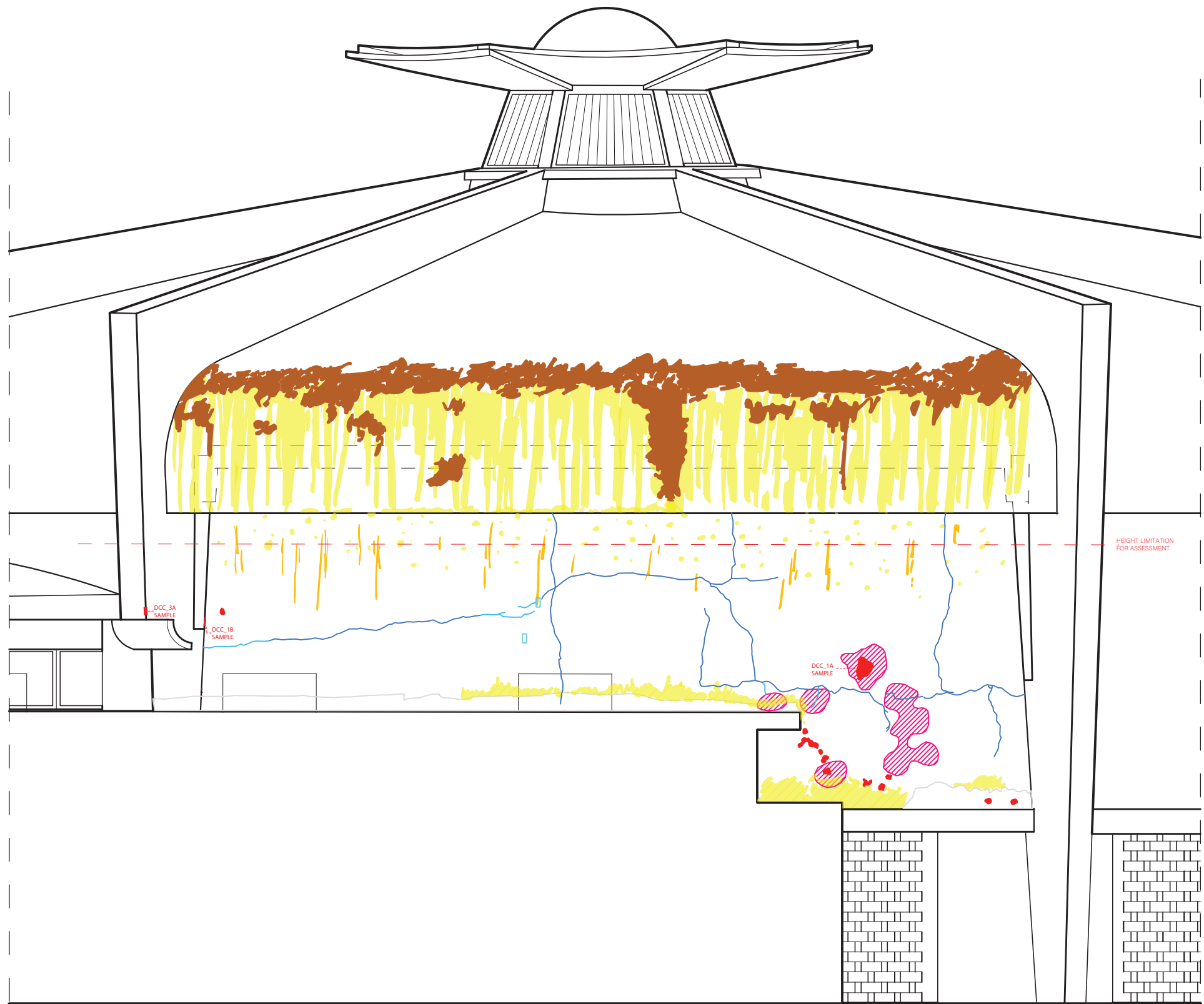
MATERIALS - FINISH & SUBSTRATE: TILTED WALL - CAST-IN-PLACE CONCRETE  
 DOME - CAST-IN-PLACE CONCRETE  
 PORTLAND CEMENT STUCCO





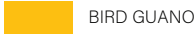





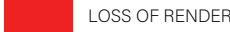

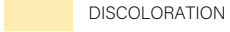

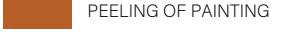

15 - SOUTHWEST ELEVATION


SCALE 1'-0" = 3/16"



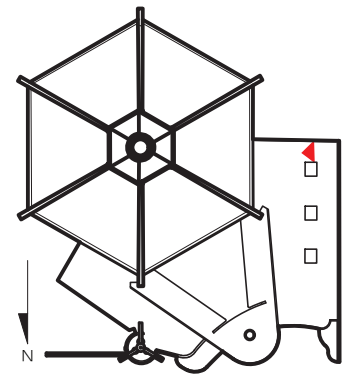


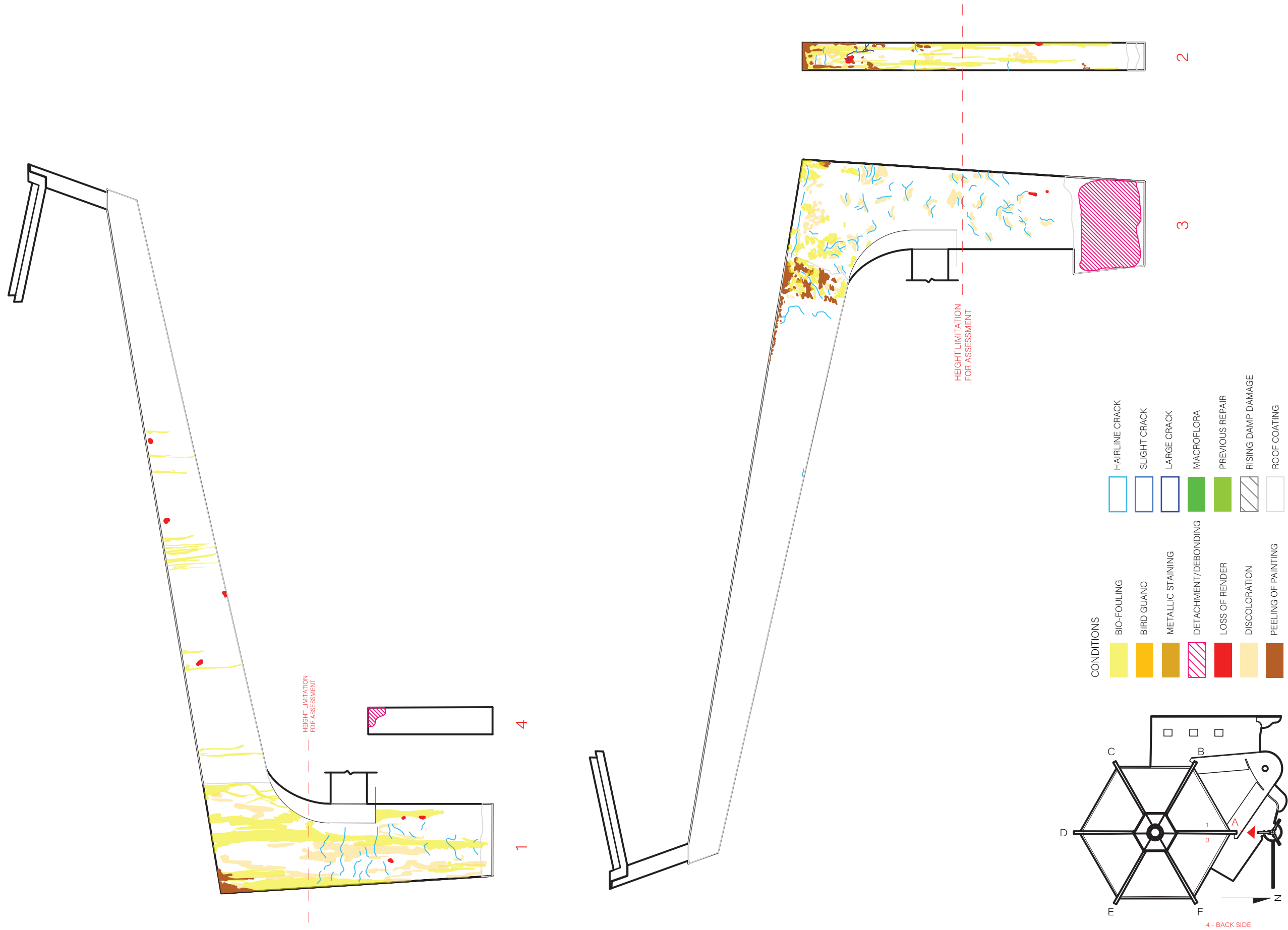
CONDITIONS

 BIO-FOULING	 HAIRLINE CRACK
 BIRD GUANO	 SLIGHT CRACK
 METALLIC STAINING	 LARGE CRACK
 DETACHMENT/DEBONDING	 MACROFLORA
 LOSS OF RENDER	 PREVIOUS REPAIR
 DISCOLORATION	 RISING DAMP DAMAGE
 PEELING OF PAINTING	 ROOF COATING

16 - WEST ELEVATION  
 SCALE 1'-0" = 3/16"  


MATERIALS - FINISH & SUBSTRATE: TILTED WALL - CAST-IN-PLACE CONCRETE  
 DOME - CAST-IN-PLACE CONCRETE  
 PORTLAND CEMENT STUCCO





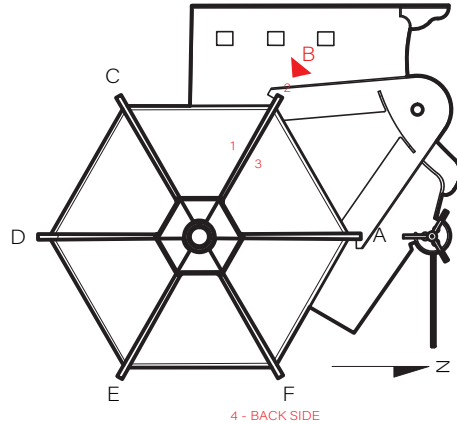
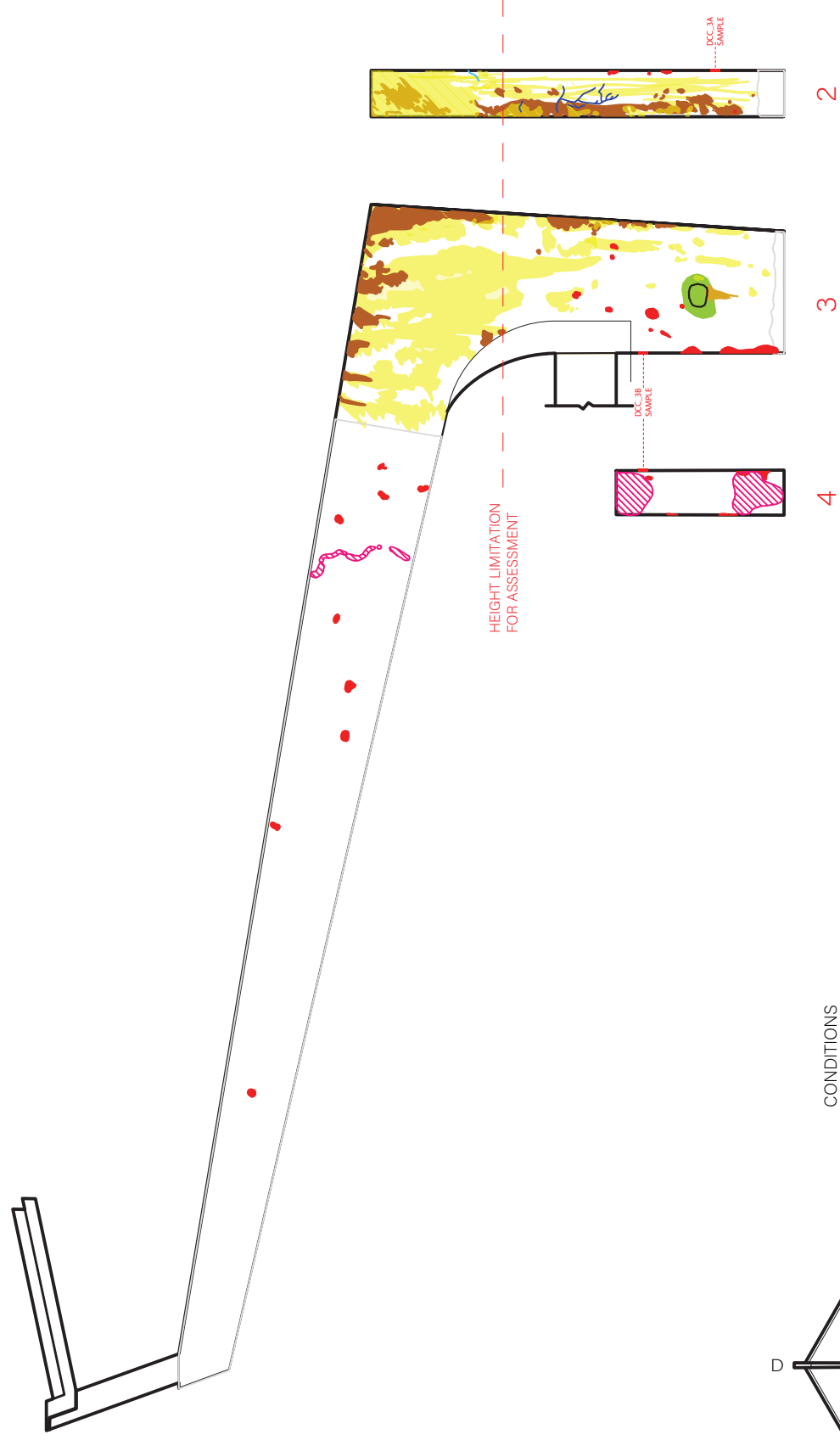
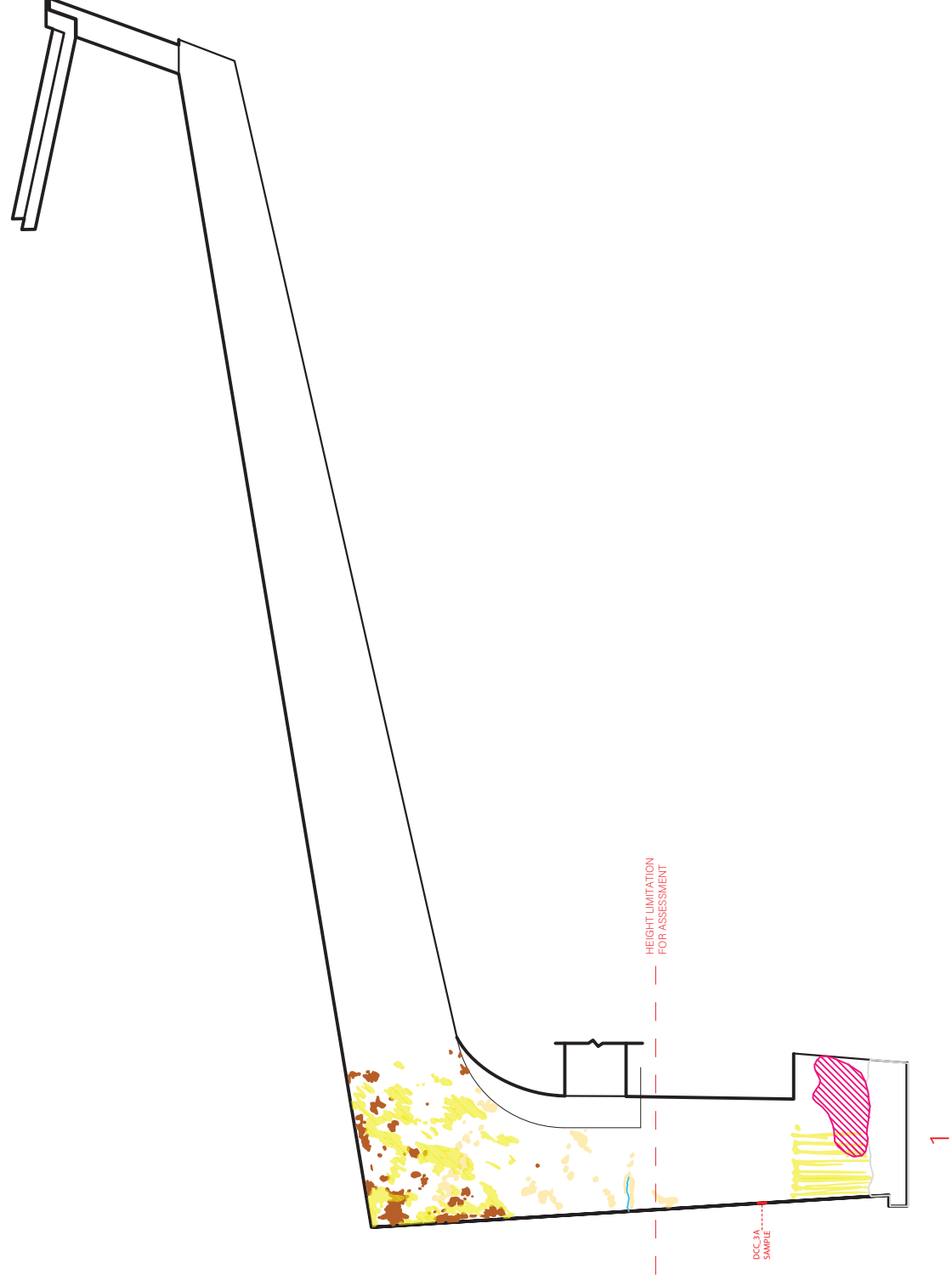
STRUCTURAL COLUMN A - NORTH SIDE

DRAWN BY: HECTOR J. BERDECIA-HERNANDEZ  
UNIVERSITY OF PENNSYLVANIA  
GRADUATE PROGRAM IN HISTORIC PRESERVATION, SCHOOL OF DESIGN

PARROQUIA NUESTRA SEÑORA DEL CARMEN  
42 CALLE EL TREN, CATAÑO, P.R. 00962

CONDITIONS ASSESSMENT  
SHEET 21 OF 26 SHEETS  
DATE JUN 1, 2020

IF REPRODUCED PLEASE CREDIT THE GRADUATE PROGRAM IN HISTORIC PRESERVATION, UNIVERSITY OF PENNSYLVANIA, NAME OF DESIGNER, DATE OF DRAWING



CONDITIONS	
	BIO-FOULING
	BIRD GUANO
	METALLIC STAINING
	DETACHMENT/DEBONDING
	LOSS OF RENDER
	DISCOLORATION
	PEELING OF PAINTING
	HAIRLINE CRACK
	SLIGHT CRACK
	LARGE CRACK
	MACROFLORA
	PREVIOUS REPAIR
	RIISING DAMP DAMAGE
	ROOF COATING

**STRUCTURAL COLUMN B - NORTHWEST SIDE**

SCALE 1'-0" = 3/16"

MATERIALS - FINISH & SUBSTRATE: CAST-IN-PLACE CONCRETE  
PORTLAND CEMENT STUCCO

DRAWN BY: HECTOR J. BERDECIA-HERNANDEZ

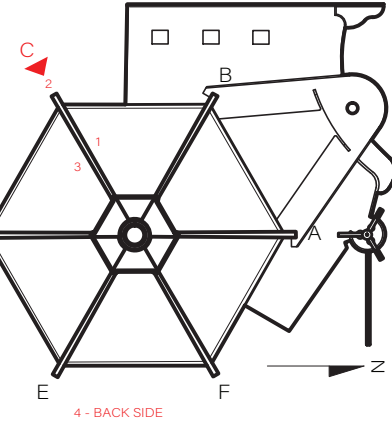
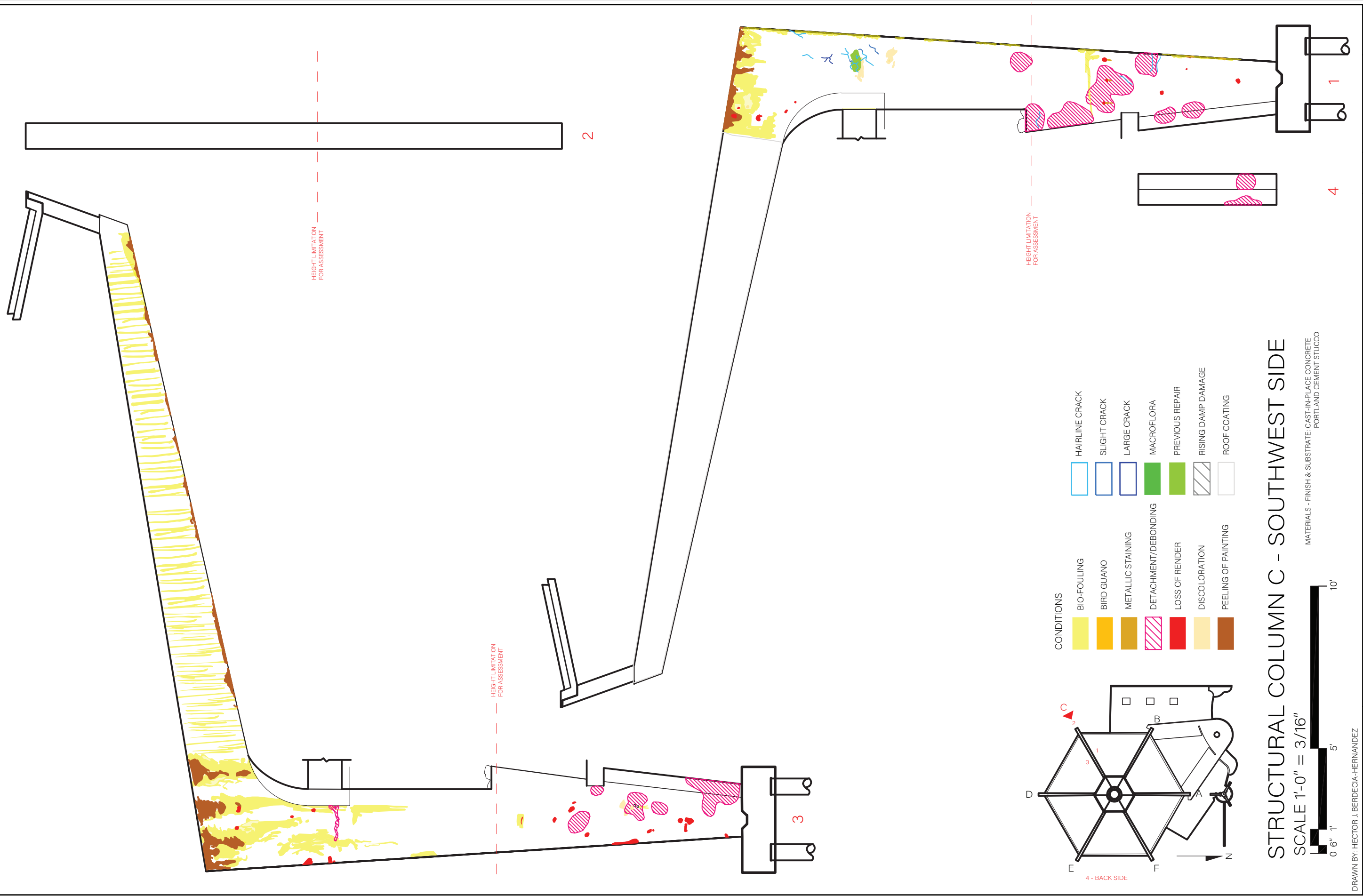
UNIVERSITY OF PENNSYLVANIA  
GRADUATE PROGRAM IN HISTORIC PRESERVATION, SCHOOL OF DESIGN

PARROQUIA NUESTRA SEÑORA DEL CARMEN  
42 CALLE EL TREN, CATAÑO, P.R., 00962

SURVEY NO.

CONDITIONS  
ASSESSMENT  
SHEET 22 OF 26 SHEETS

DATE  
JUN 1, 2020



CONDITIONS

	BIO-FOULING		HAIRLINE CRACK
	BIRD GUANO		SLIGHT CRACK
	METALLIC STAINING		LARGE CRACK
	DETACHMENT/DEBONDING		MACROFLORA
	LOSS OF RENDER		PREVIOUS REPAIR
	DISCOLORATION		RISING DAMP DAMAGE
	PEELING OF PAINTING		ROOF COATING

SCALE 1'-0" = 3/16"  
 0 6" 1'  
 5' 10'

STRUCTURAL COLUMN C - SOUTHWEST SIDE

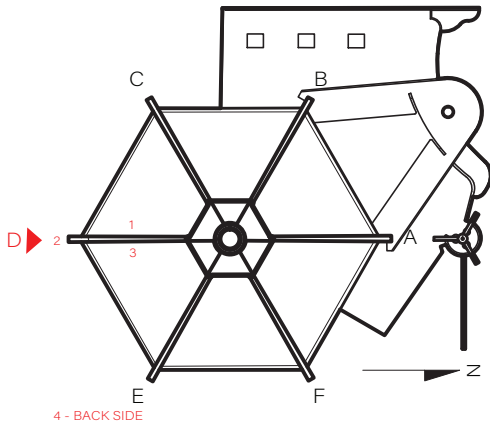
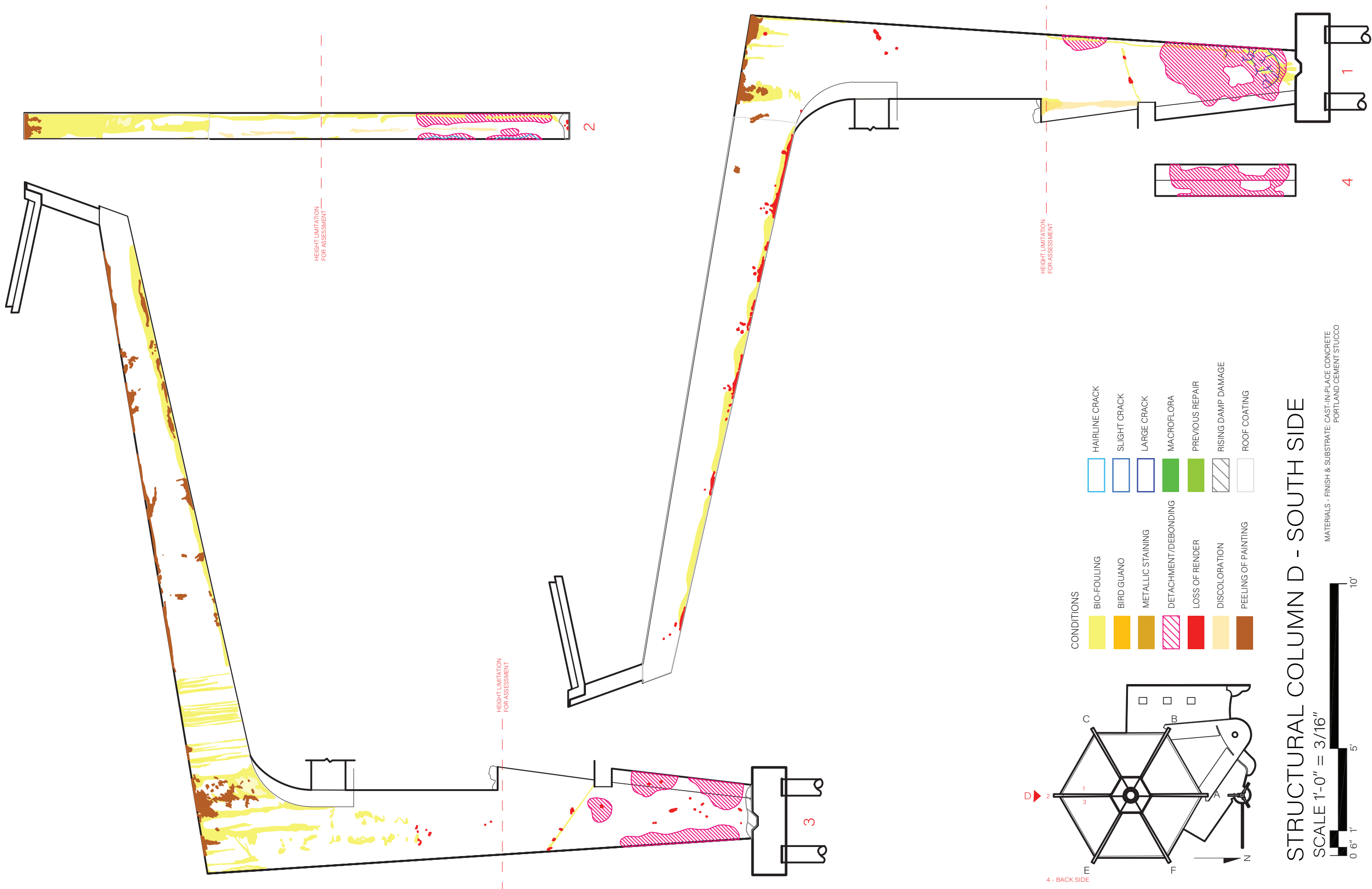
MATERIALS - FINISH & SUBSTRATE: CAST-IN-PLACE CONCRETE  
 PORTLAND CEMENT STUCCO

DRAWN BY: HECTOR J. BERDECIA-HERNANDEZ

UNIVERSITY OF PENNSYLVANIA  
 GRADUATE PROGRAM IN HISTORIC PRESERVATION, SCHOOL OF DESIGN

PARROQUIA NUESTRA SEÑORA DEL CARMEN  
 42 CALLE EL TREN, CATAÑO, P.R., 00962

SURVEY NO. DRAWINGS SHEET 23 OF 26 SHEETS DATE JUN 1, 2020



CONDITIONS

<span style="display:inline-block; width:15px; height:15px; background-color:yellow; border:1px solid black;"></span> BIO-FOULING	<span style="display:inline-block; width:15px; height:15px; background-color:orange; border:1px solid black;"></span> BIRD GUANO	<span style="display:inline-block; width:15px; height:15px; background-color:brown; border:1px solid black;"></span> METALLIC STAINING	<span style="display:inline-block; width:15px; height:15px; background: repeating-linear-gradient(45deg, transparent, transparent 2px, pink 2px, pink 4px); border:1px solid black;"></span> DETACHMENT/DEBONDING	<span style="display:inline-block; width:15px; height:15px; background-color:red; border:1px solid black;"></span> LOSS OF RENDER	<span style="display:inline-block; width:15px; height:15px; background-color:lighttan; border:1px solid black;"></span> DISCOLORATION	<span style="display:inline-block; width:15px; height:15px; background-color:darkbrown; border:1px solid black;"></span> PEELING OF PAINTING	<span style="display:inline-block; width:15px; height:15px; background-color:lightblue; border:1px solid black;"></span> HAIRLINE CRACK	<span style="display:inline-block; width:15px; height:15px; background-color:lightblue; border:1px dashed black;"></span> SLIGHT CRACK	<span style="display:inline-block; width:15px; height:15px; background-color:lightblue; border:1px solid black;"></span> LARGE CRACK	<span style="display:inline-block; width:15px; height:15px; background-color:green; border:1px solid black;"></span> MACROFLORA	<span style="display:inline-block; width:15px; height:15px; background-color:lightgreen; border:1px solid black;"></span> PREVIOUS REPAIR	<span style="display:inline-block; width:15px; height:15px; background: repeating-linear-gradient(-45deg, transparent, transparent 2px, grey 2px, grey 4px); border:1px solid black;"></span> RISING DAMP DAMAGE	<span style="display:inline-block; width:15px; height:15px; background-color:white; border:1px solid black;"></span> ROOF COATING
---	--	--	---	---	---	--	---	--	--	---	---	--	---

SCALE 1'-0" = 3/16"

0 6" 1' 5' 10'

### STRUCTURAL COLUMN D - SOUTH SIDE

MATERIALS - FINISH & SUBSTRATE: CAST-IN-PLACE CONCRETE  
PORTLAND CEMENT STUCCO

DRAWN BY: HECTOR J. BERDECIA-HERNANDEZ

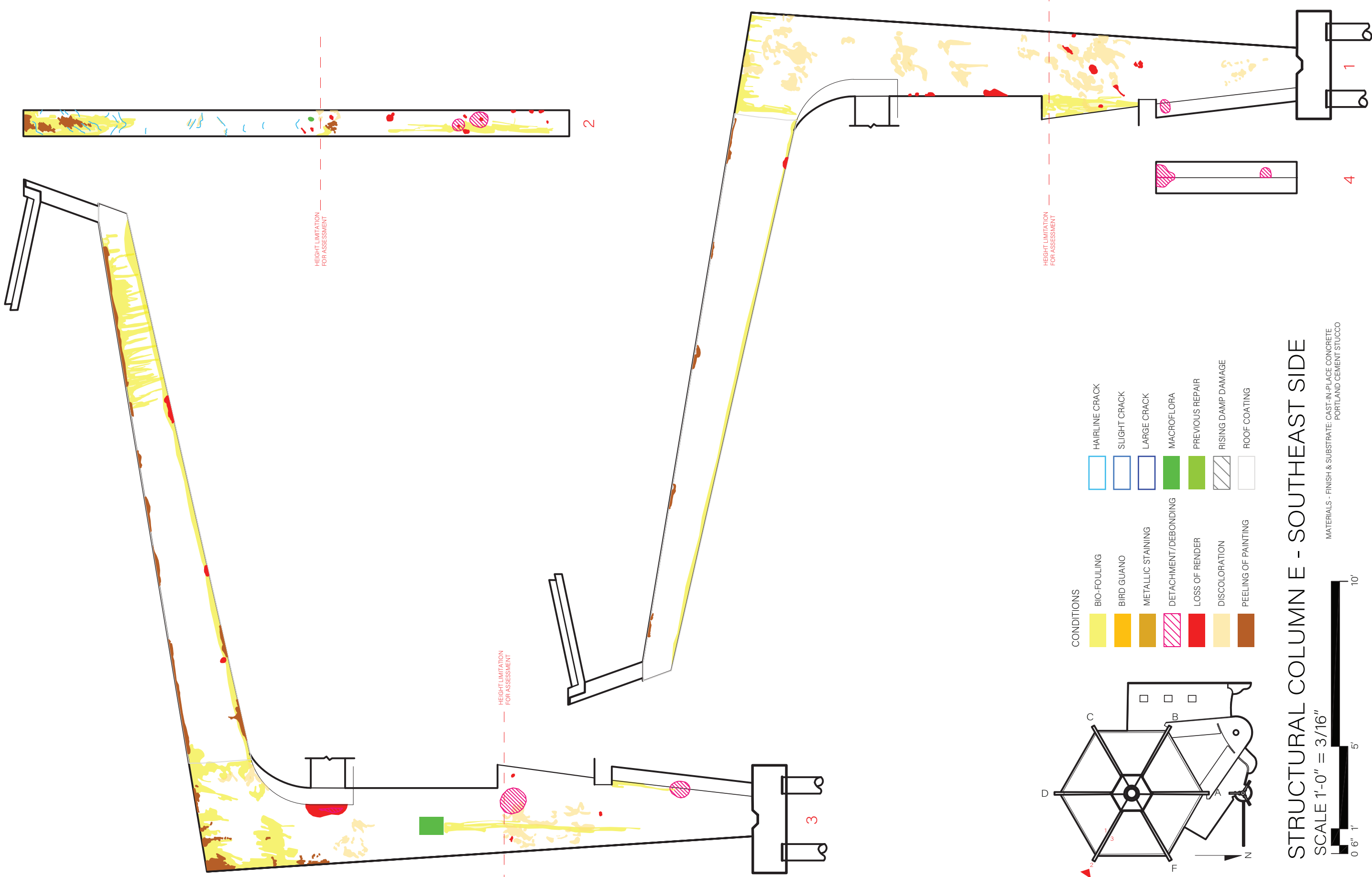
UNIVERSITY OF PENNSYLVANIA  
GRADUATE PROGRAM IN HISTORIC PRESERVATION, SCHOOL OF DESIGN

PARROQUIA NUESTRA SEÑORA DEL CARMEN  
42 CALLE EL TREN, CATANZO, P.R., 00962

CONDITIONS ASSESSMENT  
SHEET 24 OF 26 SHEETS

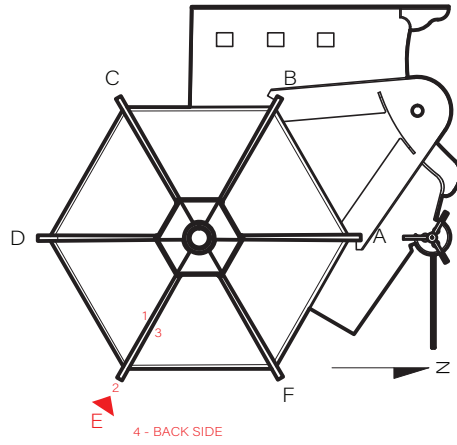
DATE  
JUN 1, 2020





CONDITIONS

	BIO-FOULING		HAIRLINE CRACK
	BIRD GUANO		SLIGHT CRACK
	METALLIC STAINING		LARGE CRACK
	LOSS OF RENDER		MACROFLORA
	DETACHMENT/DEBONDING		PREVIOUS REPAIR
	DISCOLORATION		RIISING DAMP DAMAGE
	PEELING OF PAINTING		ROOF COATING



**STRUCTURAL COLUMN E - SOUTHEAST SIDE**  
 SCALE 1'-0" = 3/16"

MATERIALS - FINISH & SUBSTRATE: CAST-IN-PLACE CONCRETE  
 PORTLAND CEMENT STUCCO



DRAWN BY: HECTOR J. BERDECIA-HERNANDEZ

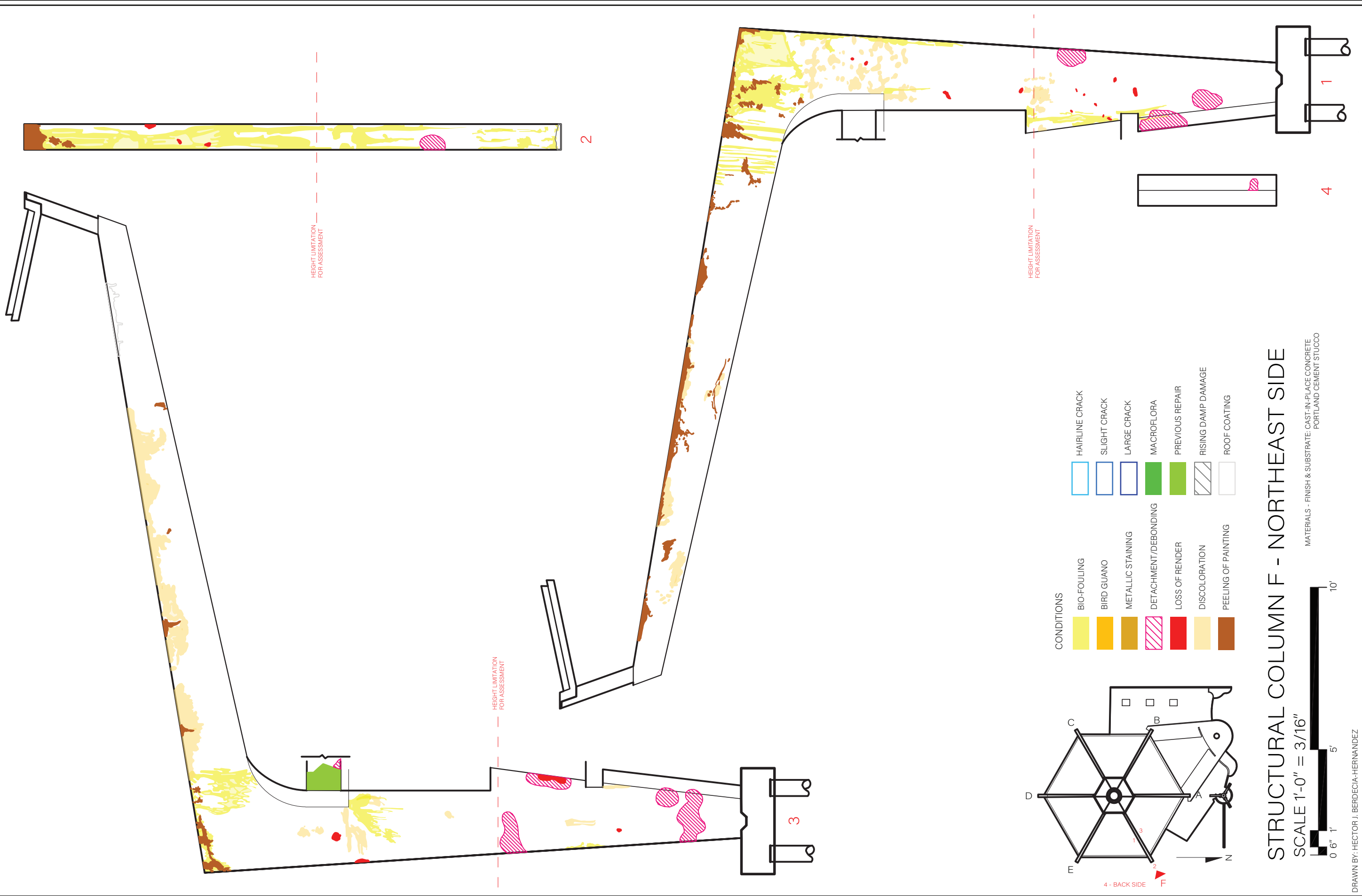
UNIVERSITY OF PENNSYLVANIA  
 GRADUATE PROGRAM IN HISTORIC PRESERVATION, SCHOOL OF DESIGN

PARROQUIA NUESTRA SEÑORA DEL CARMEN  
 42 CALLE EL TREN, CATAÑO, P.R., 00962

SURVEY NO.

CONDITIONS  
 ASSESSMENT  
 SHEET 25 OF 26 SHEETS

DATE  
 JUN 1, 2020



**STRUCTURAL COLUMN F - NORTHEAST SIDE**  
SCALE 1'-0" = 3/16"

DRAWN BY: HECTOR J. BERDECIA-HERNANDEZ  
UNIVERSITY OF PENNSYLVANIA  
GRADUATE PROGRAM IN HISTORIC PRESERVATION, SCHOOL OF DESIGN

PARROQUIA NUESTRA SEÑORA DEL CARMEN  
42 CALLE EL TREN, CATAÑO, PR., 00962

CONDITIONS ASSESSMENT  
SHEET 26 OF 26 SHEETS

DATE  
JUN 1, 2020

Table A2.1 – Conditions per Elevation

#	Elevation	Description	Conditions (Top 3 conditions in <b>Bold</b> ) *Based on occurrence for the total area
1	Elevation 1	Reinforced concrete block & troweled applied stucco + poured-in-place eaves	<b>Rising damp</b> <b>Loss of stucco</b> <b>Detachment/Debonding</b> Peeling Discoloration Macroflora
2	Elevation 2	Reinforced concrete block & troweled applied stucco + poured-in-place eaves	<b>Detachment/Debonding</b> <b>Rising damp</b> <b>Cracks</b> Surface fouling Discoloration Peeling
3	Elevation 3A	Reinforced concrete block & troweled applied stucco	<b>Surface fouling</b> <b>Macroflora</b> <b>Cracks</b> Loss of stucco Rising Damp Peeling
4	Elevation 3B	Reinforced concrete block & troweled applied stucco	<b>Surface fouling</b> <b>Cracks</b> <b>Loss of stucco</b> Rising Damp Peeling
5	Elevation 4	Reinforced concrete block & troweled applied stucco	<b>Detachment/Debonding</b> <b>Loss of stucco</b> <b>Surface fouling</b> Peeling Discoloration Rising Damp
6	Elevation 5	Reinforced concrete block & troweled applied stucco	<b>Cracks</b> <b>Loss of stucco</b> <b>Macroflora</b> Metallic staining - Corrosion Surface fouling

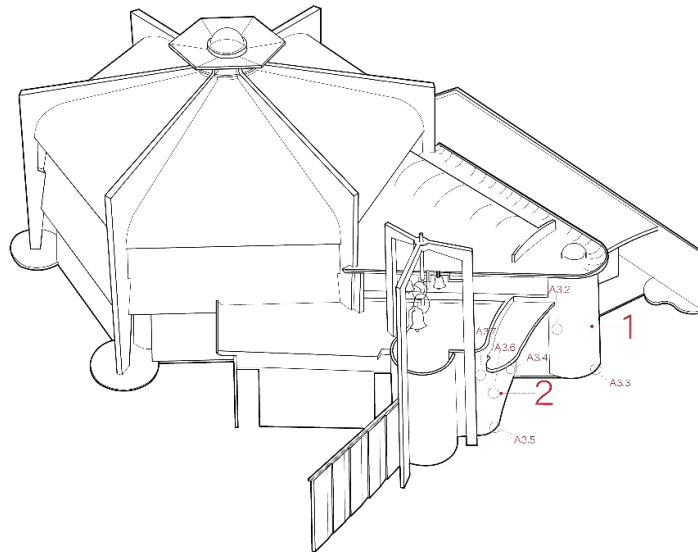
7	Elevation 6A	Pre-cast panels (No stucco)	<b>Cracks</b> <b>Rising Damp</b> <b>Macroflora</b> Surface fouling Metallic Staining - Corrosion
8	Elevation 6B	Pre-cast panels (No stucco)	<b>Cracks</b> <b>Rising Damp</b> <b>Surface fouling</b> Macroflora Metallic Staining
9	Elevation 7	Reinforced concrete block & troweled applied stucco + poured-in-place eave	<b>Loss of stucco</b> <b>Detachment/Debonding</b> <b>Surface fouling</b> Cracks Rising Damp Metallic Staining - Corrosion
10	Elevation 8A	Poured-in-place & troweled applied stucco (Dome with ferrous metallic aggregate)	<b>Cracks</b> <b>Peeling</b> <b>Surface fouling</b>
11	Elevation 8B	Poured-in-place wall & spray-applied/shotcrete stucco	<b>Cracks</b> <b>Peeling</b> <b>Surface fouling</b>
-	Elevation 9	Roof slab	Water ponding Cracking Surface fouling Peeling
12	Elevation 10A	Poured-in-place walls & eaves	<b>Discoloration</b> <b>Peeling</b> <b>Cracks</b> Loss of stucco Previous repairs
13	Elevation 10B	Poured-in-place walls & eaves	<b>Discoloration</b> <b>Peeling</b> <b>Cracks</b> Loss of stucco Previous repairs

			Detachment/Debonding (belongs to the wall on Elevation 1)
14	Elevation 11A	Reinforced concrete block & spray-applied/shotcrete stucco	<b>Detachment/Debonding</b> <b>Loss of stucco</b> <b>Cracks</b> Peeling Surface fouling Irregular coatings
15	Elevation 11B	Reinforced concrete block & spray-applied/shotcrete stucco	<b>Peeling</b> <b>Detachment/Debonding</b> <b>Loss of stucco</b> Surface fouling Cracks Irregular coatings Metallic staining
16	Elevation 11C	Reinforced concrete block & spray-applied/shotcrete stucco	<b>Cracks</b> <b>Detachment/Debonding</b> <b>Peeling</b> Loss of stucco Surface fouling Irregular coatings Metallic staining - Corrosion Possible Alkali-Silica Reaction
17	Elevation 12	Poured-in-place & troweled applied stucco (Dome with ferrous metallic aggregate) + Poured-in-place wall & spray-applied/shotcrete stucco	<b>Cracks</b> <b>Surface fouling</b> <b>Detachment/Debonding</b> Loss of stucco Bird Guano Peeling
18	Elevation 13	Poured-in-place & troweled applied stucco (Dome with ferrous metallic aggregate) + Poured-in-place wall & spray-applied/shotcrete stucco	<b>Detachment/Debonding</b> <b>Cracks</b> <b>Loss of stucco</b> Macroflora Surface fouling Bird Guano Discoloration
19	Elevation 14	Poured-in-place & troweled applied stucco (Dome with ferrous	<b>Detachment/Debonding</b> <b>Loss of stucco</b> <b>Cracks</b>

		metallic aggregate) + Poured-in-place wall & spray-applied/shotcrete stucco	Surface fouling Discoloration Bird Guano
20	Elevation 15	Poured-in-place & troweled applied stucco (Dome with ferrous metallic aggregate) + Poured-in-place wall & spray-applied/shotcrete stucco	<b>Detachment/Debonding</b> <b>Loss of stucco</b> <b>Cracks</b> Surface fouling Discoloration Bird Guano
21	Elevation 16	Poured-in-place & troweled applied stucco (Dome with ferrous metallic aggregate) + Poured-in-place wall & spray-applied/shotcrete stucco	<b>Cracks</b> <b>Detachment/Debonding</b> <b>Surface fouling</b> Loss of stucco Peeling Bird Guano Roof painting
22	Column A	Poured-in-place & spray- applied/shotcrete stucco	<b>Cracks</b> <b>Surface fouling</b> <b>Discoloration</b> Loss of stucco Peeling Detachment/Debonding
23	Column B	Poured-in-place & spray- applied/shotcrete stucco	<b>Surface fouling</b> <b>Loss of stucco</b> <b>Cracks</b> Peeling Detachment/Debonding Previous repair
24	Column C	Poured-in-place & spray- applied/shotcrete stucco	<b>Detachment/Debonding</b> <b>Loss of stucco</b> <b>Surface fouling</b> Cracks Macroflora Peeling
25	Column D	Poured-in-place & spray- applied/shotcrete stucco	<b>Detachment/Debonding</b> <b>Loss of stucco</b> <b>Surface fouling</b>

			Discoloration Cracks – Alkali-Silica Reaction Peeling
26	Column E	Poured-in-place & spray-applied/shotcrete stucco	<b>Macroflora</b> <b>Loss of stucco</b> <b>Discoloration</b> Cracks Surface fouling Peeling Detachment/Debonding
27	Column F	Poured-in-place & spray-applied/shotcrete stucco	<b>Detachment/Debonding</b> <b>Surface fouling</b> <b>Loss of stucco</b> Peeling Previous Repair

**Northside – Main entrances – Elevations 1 & 2**



*Fig. A2.1 – Distribution of Elevations 1 & 2 with location of Figures A3.2 – A3.7. Graphics by Author, 2020.*



*Figs. A2.2 & A2.3 – Scaling and rising damp issues on Elevation 1. As the main entrance to the church, a big sign was originally installed using screws and eventually removed. At least two paint coatings could be identified in the wall. Photos by Author, 2020.*



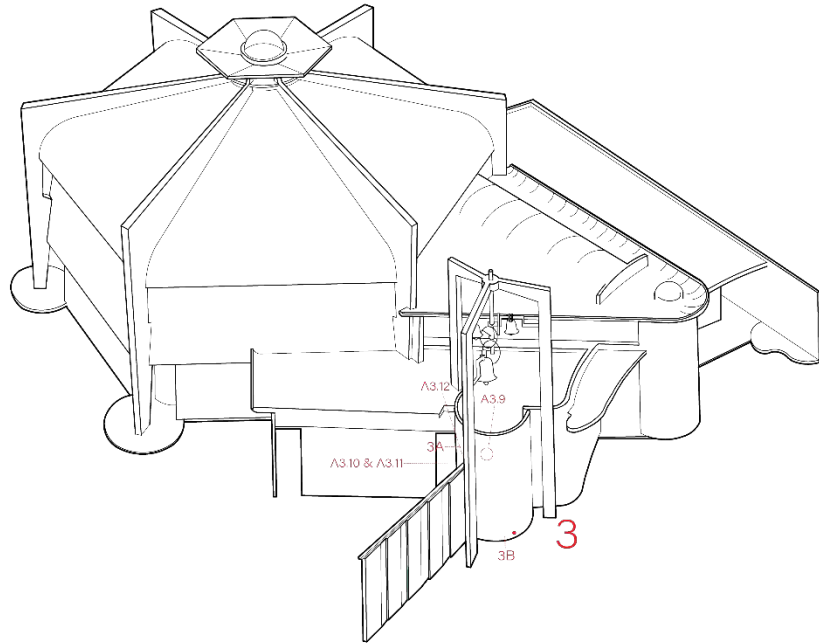
*Figs. A2.4 & A2.5 – Rising damp, discoloration and paint peeling issues on Elevation 2. Photos by Author, 2020.*





*Figs. A2.6 & A2.7* – The wall is also affected by a small drainage in the curved eave which manage rainwater directly to the wall and concrete floor. A continuous horizontal crack in the wall surface is a sign of steel reinforce corrosion on the concrete masonry. Photos by Author, 2020.

## Elevation 3



*Fig. A2.8*– Distribution of Elevation 3 (3A & 3B) with location of Figures A3.9 – A3.12. Graphics by Author, 2020.

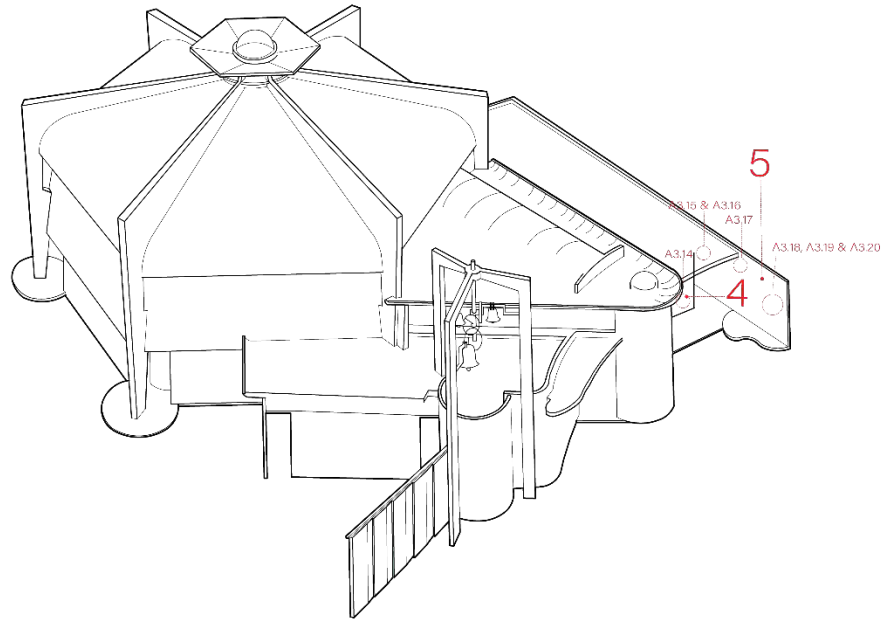


*Fig. A2.9* – In elevation 3 two different paint coating applications can be found. A horizontal continuous slight crack along the concrete masonry wall show signs of steel reinforced corrosion. A vertical crack stained by mold is also seen on the top part of Side A. Photos by Author, 2020.



*Figs. A2.10, A2.11 & A2.12 - Water ponding due to the new drainage along poor water management issues have increased the chance of development of micro and macro biogrowth on Side B of Elevation 3. These include mold growth, leafy plants and insects living on scaled stucco. Photos by Author, 2020.*

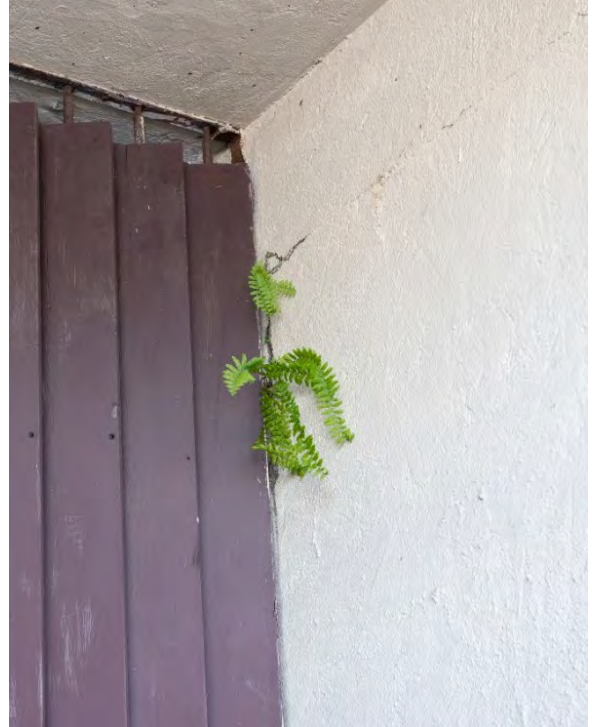
## Elevations 4 & 5



*Fig. A2.13 – Distribution of Elevation 4 & 5 with location of Figures A3.14-A3.20. Graphics by Author, 2020.*



*Fig. A2.14 – Major scaling, rinsing damp and paint peeling issues can be seen in Elevation 4. Photo by Author, 2020.*

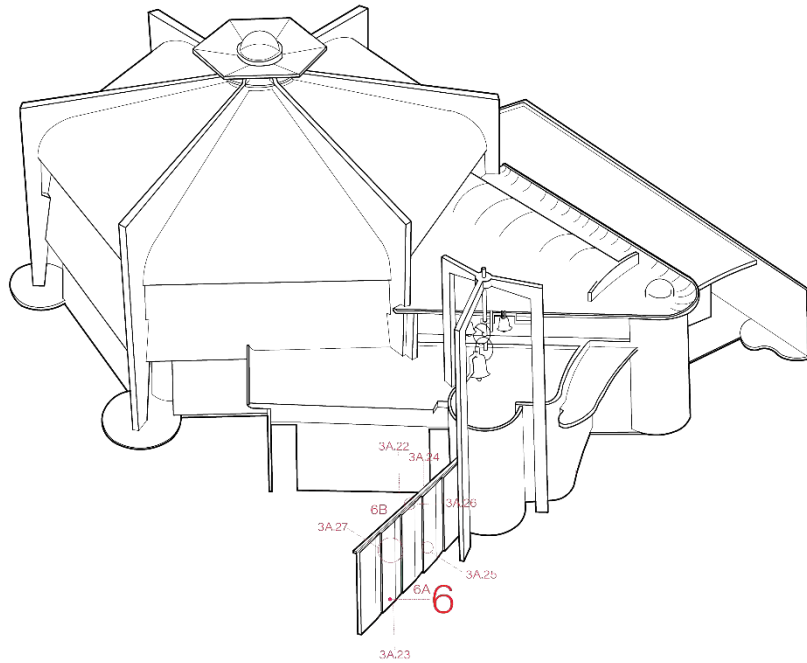


*Figs. A2.15, A2.16 & A2.17- Scaling along detachment/debonding and discoloration of stucco near the entrance in Elevation 4 (top left photo). Macro biogrowth and development of vertical and horizontal slight/hairline as sign of reinforced corrosion on Elevation 5 (top right and bottom photos). Photos by Author, 2020.*



*Fig. A2.18, A2.19 & A2.20 – Two different paint coatings can be found on Elevation 5 along corroding nails and screws from an earlier sign (top photo). The original sign on the wall was installed in 2012 (bottom left photo) & removed c.2015 (bottom right photo). The original entrance signs are present in the 2015 photo. Photos by Author, 2020; Andrés Rivera, 2012 & Luis E. Carraza, 2015.*

## Elevation 6



*Fig. A2.21 – Distribution of Elevation 6 (6A & 6B) with location of Figures A3.22-A3.27. Graphics by Author, 2020.*



*Fig. A2.22 – Remaining palm trees and other large leafy plants close contact with the precast panels. The original paint from the church's exterior surfaces is also visible from this side. Photo by Javier Freytes, 2019.*



*Fig. A2.23 - Del Carmen Church in 2017 before Hurricane María with all palm trees and vegetation. Source: Luis E. Carrazo, 2017*



*Fig. A2.24 & A2.25 –Soiling and mold issues on the surfaces of the precast panels on Side B (left photo). Diagonal slight cracking due to steel corrosion on Side A of the precast panels (right photo). Photos by Author, 2020.*





Fig. A2.26 & A2.27 – Cracking issues along the precast members of Elevation 6. Photos by Author, 2020.

## Elevation 7

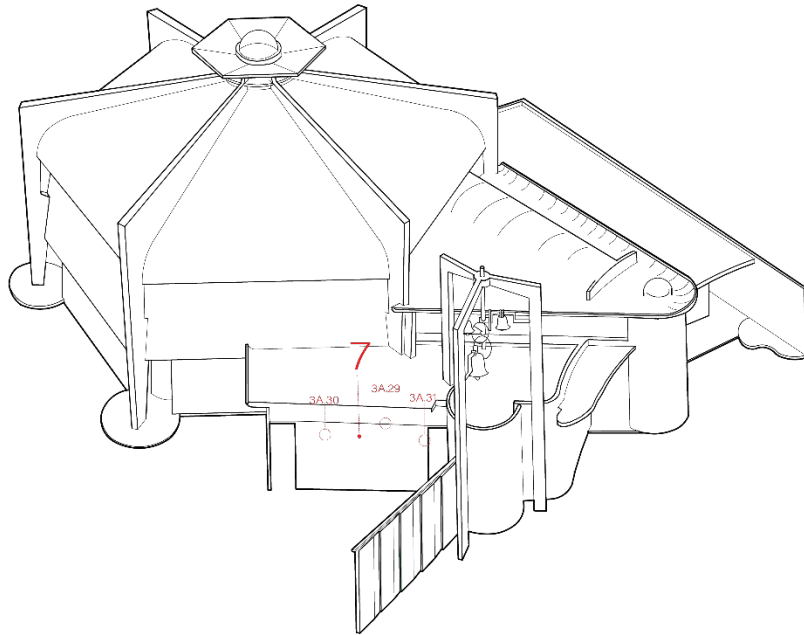


Fig. A2.28 – Distribution of Elevation 7 with location of Figures A3.29 – A3.31. Graphics by Author, 2020.

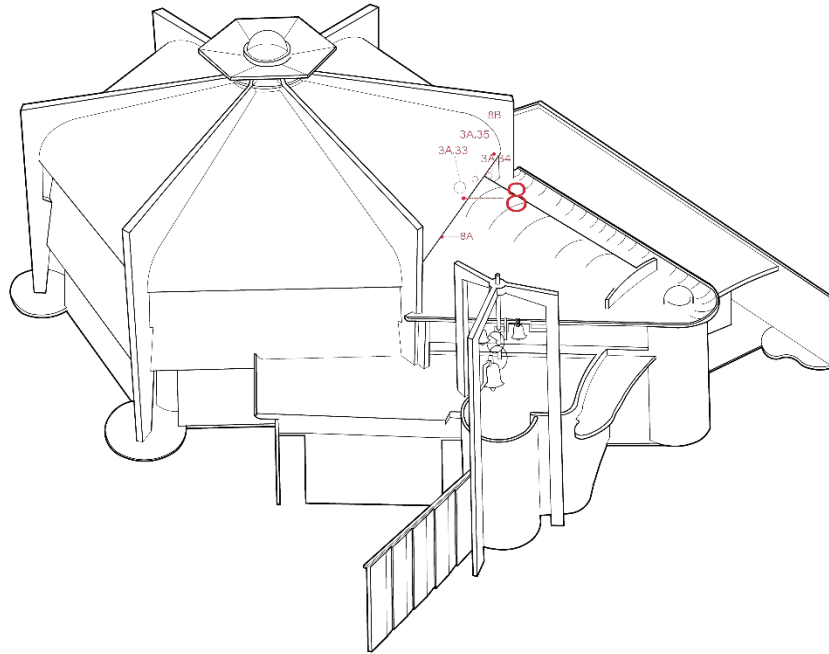


*Fig. A2.29* – Slight vertical cracking, paint peeling and soiling issues on the eaves of Elevation 7. Photos by Author, 2020.



*Fig. A2.30 & A2.31* – Scaling of stucco and corrosion staining over the surfaces of Elevation 7. Photos by Author, 2020

## Elevation 8



*Fig. A2.32 – Distribution of Elevation 8 (8A & 8B) with location of Figures A3.33 – A3.35. Graphics by Author, 2020.*



*Fig. A2.33 – Surface fouling and paint peeling/deterioration on Elevation 8 (top photo). Photo by Author, 2020.*



*Fig. A2.34* –Detaching/debonding areas with small hairline diagonal cracks on the stuccoed tilted wall on Elevation 8. Photos by Author, 2020.



*Fig. A2.35* – Vertical and horizontal microcracking, paint peeling and moisture issues on the surfaces of the dome on Elevation 8. Photo by Author, 2020.

## Elevation 9

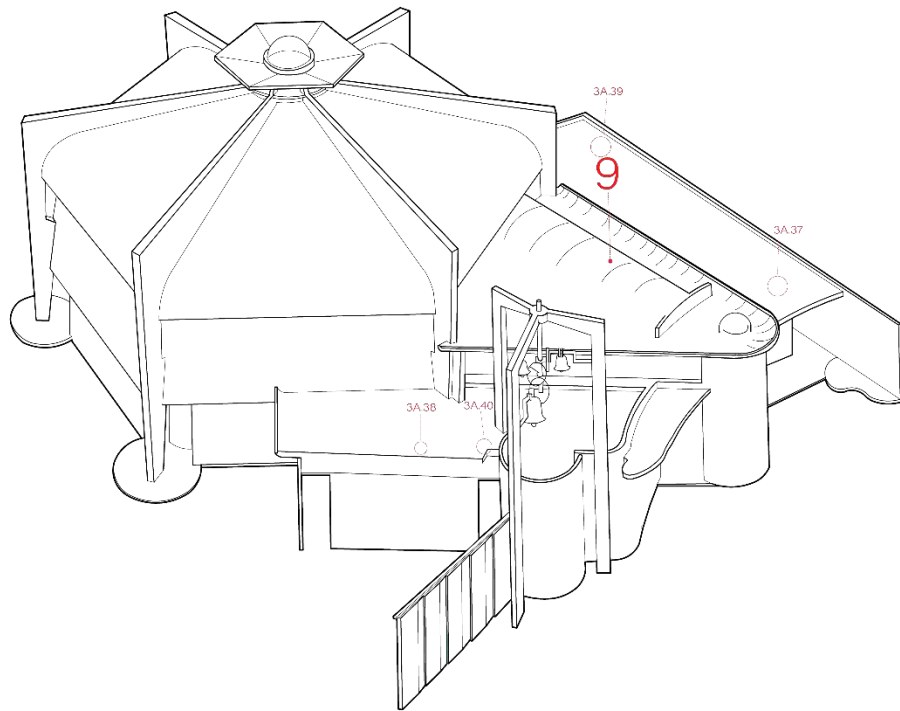


Fig. A2.36 – Distribution of Elevation 9 with location of Figures A3.37-A3.40. Graphics by Author, 2020.



Fig. A2.37 – Current condition of the roof slabs on the west side of the church - Elevation 9. Photo by Author, 2020.

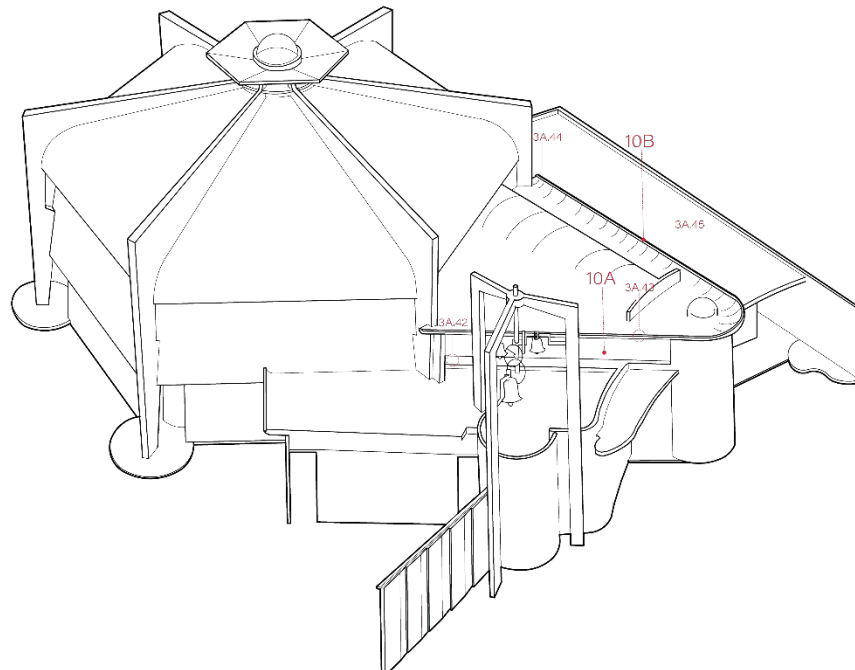


*Fig. A2.38*– Broken 'Type A' original roof drainage on roof slab near baptistry and confessionary – East side (bottom photo). Photo by Author, 2020



*Figs. A2.39 & A2.40* – A broken drainage from building on the west side of the church creates a massive water ponding issue on the roof slab. The two original 'Type B' drains are not working (left photo). New installed drainage which leads to water ponding, increasing moisture and bio-growth issues on Elevation 3. This new drainage is the only one properly functioning on the roof (right photo). Photos by Author, 2020.

## Elevations 10A & 10B



*Fig. A2.41 – Distribution of Elevations 10A & 10B with location of Figures A3.42 – A3.45. Graphics by Author, 2020.*

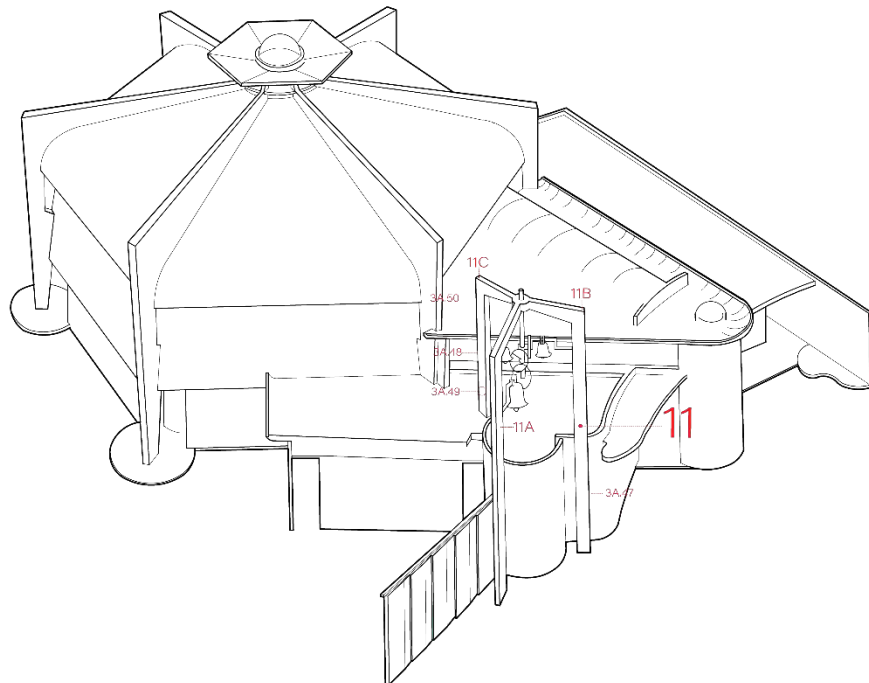


*Figs. A2.42 & A2.43 - The original glass louvers can be found at the roof (left photo). Cracking, an improper repair and discoloration of the eaves in Elevation 10A (right photo). Photos by Author, 2020.*



*Figs. A2.44 & A2.45 – Major paint peeling, cracking and improper repairs in Elevation 10B. The sealing grey coating has also been applied to these concrete elements with a new paint coating of painting. Photos by Author, 2020.*

**Elevation 11 – Belfry/Bell Tower (11A, 11B, 11C)**



*Fig. A2.46 – Distribution of Elevation 11 (11A, 11B & 11C) with location of Figures A3.47 – A3.50. Graphics by Author, 2020.*



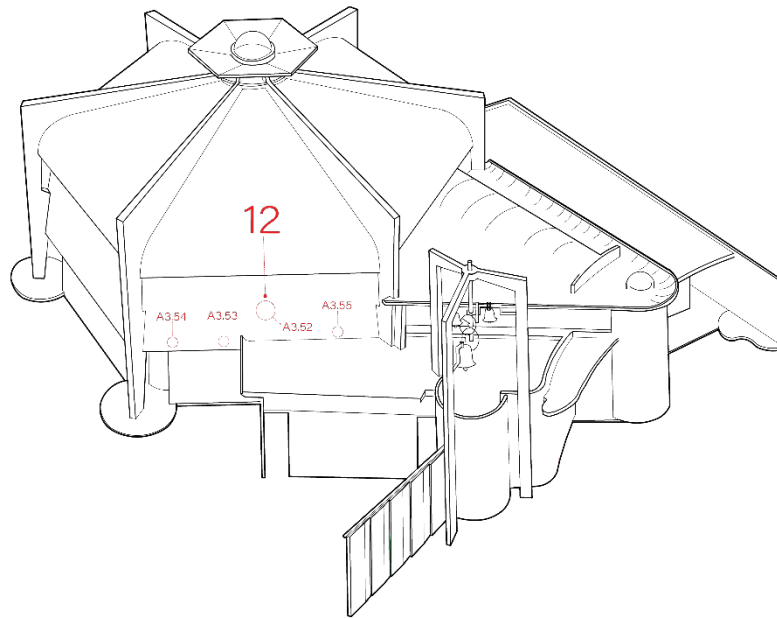


*Figs. A2.47 & A2.48 – Diagonal cracking, discoloration, scaling and paint peeling issues on reinforced concrete masonry belfry. Photos by Author, 2020.*



*Figs. A2.49 & A2.50 – Improper repairs, paint peeling, discoloration, humidity and possible alkali-aggregate reaction (AAR) issue (as defined by Poole & Sims, 2016) on Elevation 11C of the belfry. Photos by Author, 2020.*

## Elevation 12



*Fig. A2.51* – Distribution of Elevation 12 with location of Figures A3.52 – A3.55. Graphics by Author, 2020.



*Fig. A2.52* – The application of a sealing coating to the stuccoed wall is causing moisture, bio-fouling and discoloration issues. Photos by Author, 2020.

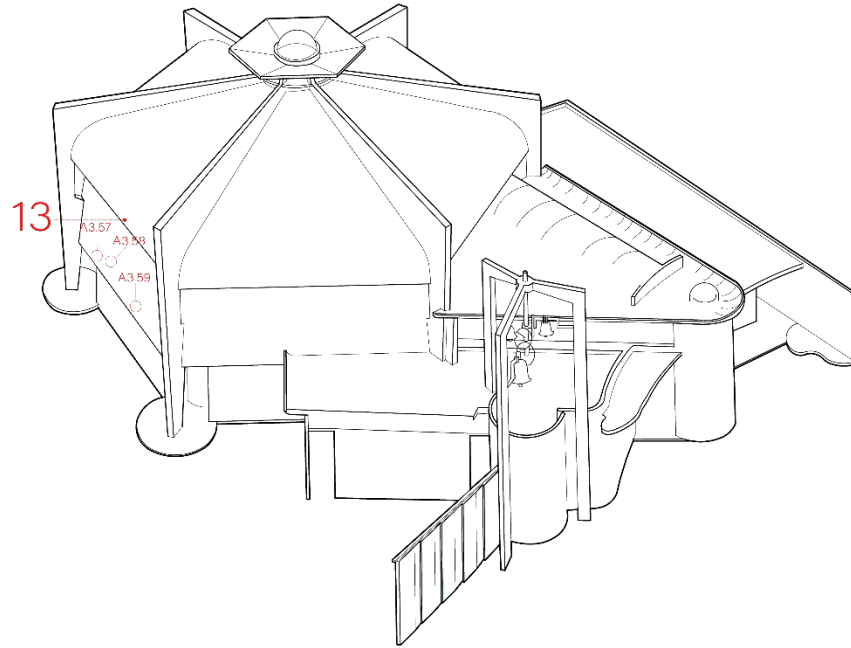


*Fig. A2.53* – Bio-fouling growth and atmospheric soiling issues on the lower side of Elevation 12. Photos by Author, 2020.



*Figs. A2.54 & A2.55 – Horizontal and vertical highline cracks, minor detachment/debonding sections and scaling along the surfaces. Photos by Author, 2020*

## Elevation 13

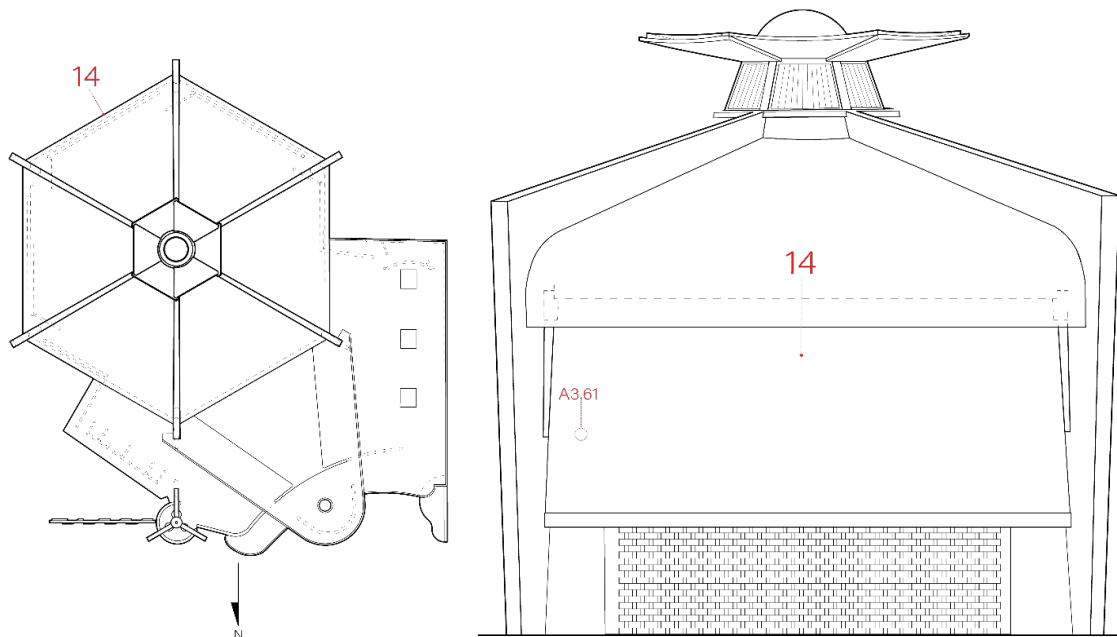


*Fig. A2.56 – Distribution of Elevation 13 with location of Figures A3.57 – A3.59. Graphics by Author, 2020.*



*Figs. A2.57, A2.58 & A2.59 – Highline cracks along discoloration sections and scaled portions of the stucco in Elevation 13 (top photos). Original stucco patches -now covered- show the uneven workmanship over the exposed surfaces. Photos by Author, 2020.*

## Elevation 14

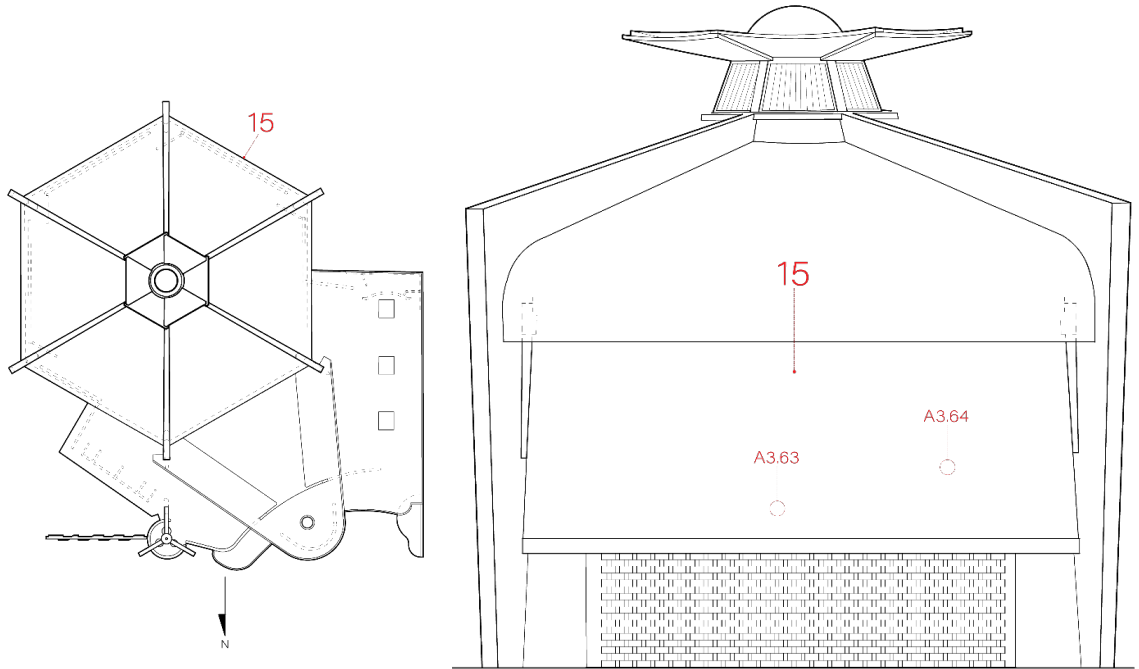


*Fig. A2.60* – Distribution of Elevation 14 with location of Figure A3.61. Graphics by Author, 2020.



*Fig. A2.61* – A diagonal slight crack and soiling are among the conditions in Elevation 14. Photos by Author, 2020.

**Elevation 15**



*Fig. A2.62 – Distribution of Elevation 15 with location of Figures A3.63 & A3.64. Graphics by Author, 2020.*





*Fig. A2.63 & A2.64* – Large scaled stuccoed surfaces, fouling and guano issues on Elevation 15. Photos by Author, 2020

## Elevation 16

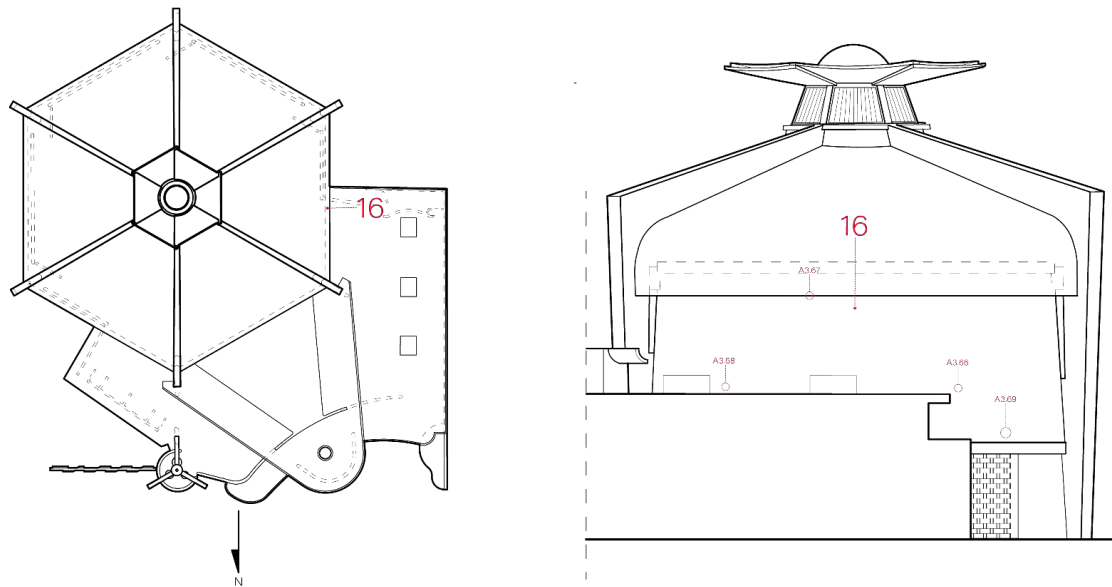


Fig. A3.65 – Distribution of Elevation 16 with location of Figures A3.66 – A3.69. Graphics by Author, 2020.



Fig. A2.66 & A2.67 – Elevation 16 showed some scaling and detachment/debonding conditions. Fouling and deterioration under the stucco layer is particularly visible in this section of the Elevation (left photo). Guano and soiling issues on the wall and a broken pigeon netting (right photo). Photo by Author, 2020.



*Figs. A2.68 & A2.69 – Cracking, scaling, guano, mold growth, fouling and moisture issues on Elevation 16. The roof sealing and waterproof coating was also applied to the base of the wall. Photo by Author, 2020.*

## Structural Column A

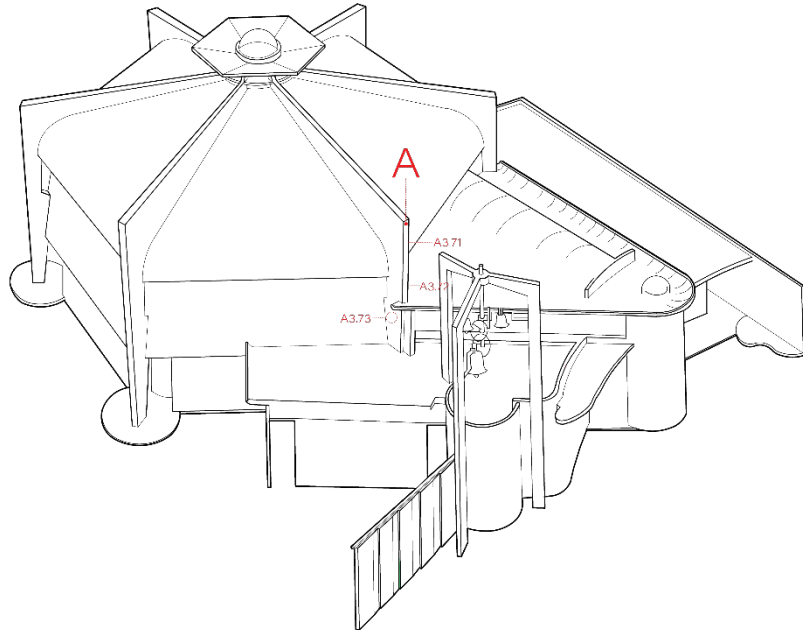


Fig. A2.70 – Structural column A with location of Figures A3.71 – A3.73. Graphics by Author, 2020.



Figs. A2.71 & A2.72 – Discoloration, fouling and paint peeling conditions on Column A (left). Small detachment/debonding area behind Column A (right). Photos by Author, 2020.



Fig. A2.73 – Discoloration, fouling and paint peeling conditions on Column A. Photo by Author, 2020.

### Structural Column B

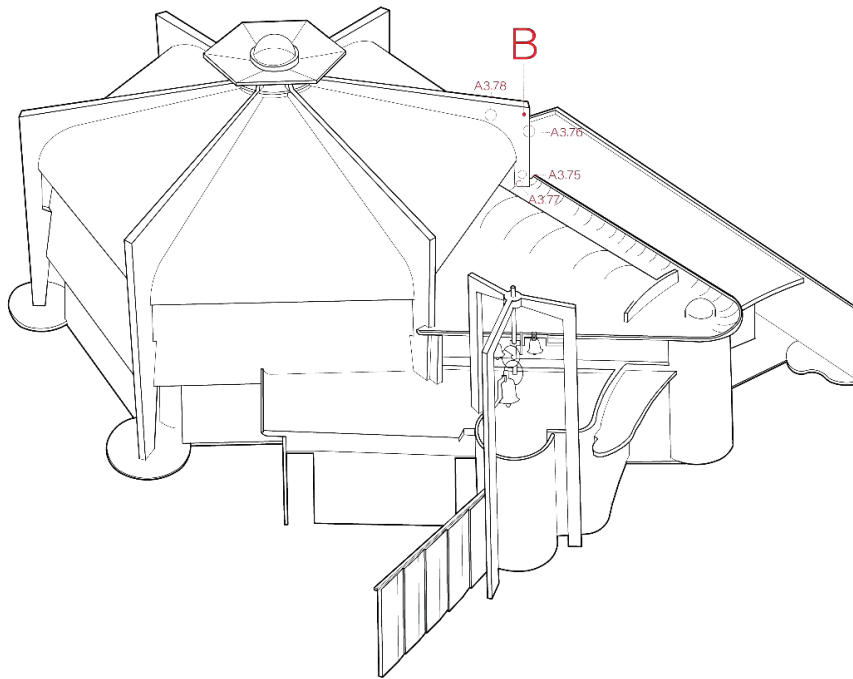
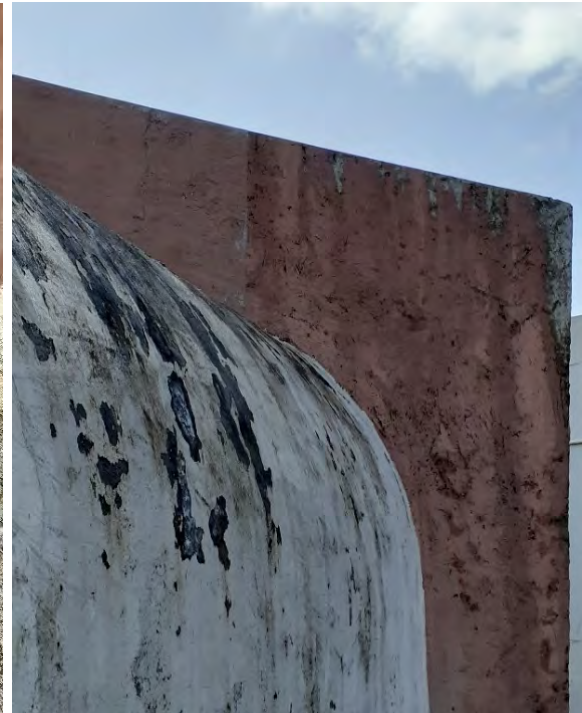


Fig. A3.74 – Structural column B with location of Figures A3.75 -A3.78. Graphics by Author, 2020.



*Fig. A2.75 & A2.76 – Detachment/debonding areas on the back of Column B. Other conditions include scaling, discoloration, fouling, mold growth and paint peeling. A corroded electrical metallic socket can be seen on the lower part of the column. Photos by Author, 2020.*



*Fig. A2.77 & A2.78 – The roof sealing paint was applied to the base of both Column B and Column A. Also, the gray sealing coating was applied in the upper parts of the column (see the differences in layers). Photos by Author, 2020.*

## Structural Column C

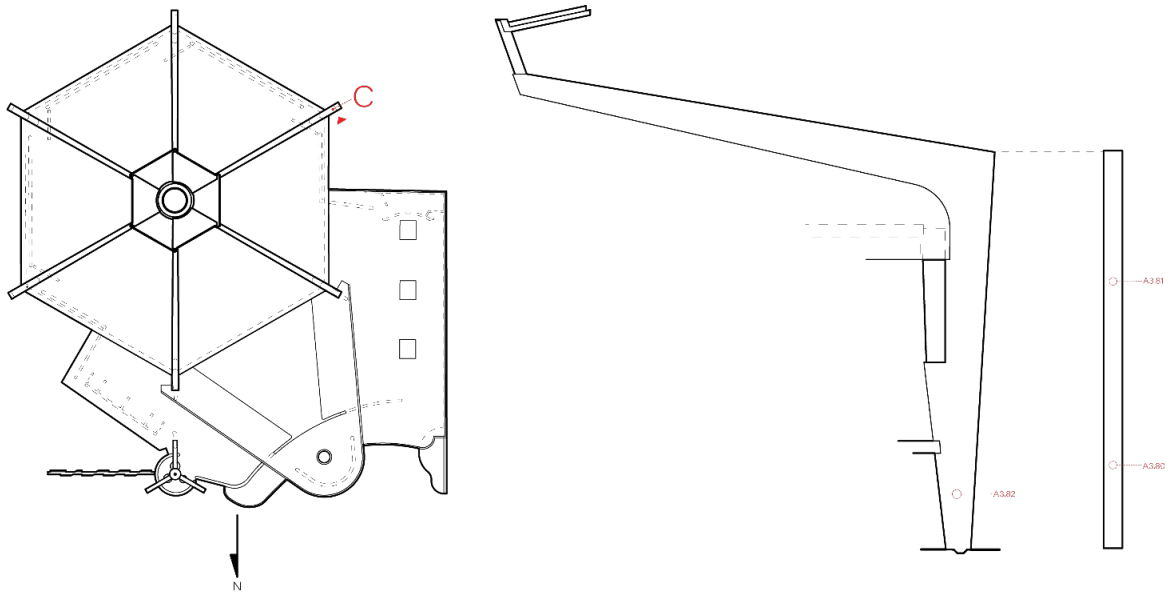


Fig. A2.79 – Structural column C with location of Figures A3.80 – A3.82. Graphics by Author, 2020.



Fig. A2.80 – Scaling and fouling issues on Column C. Photo by Author, 2020.



Fig. A2.81 & A2.82 – Surface fouling, mold growth and paint peeling on Column C (left photo). Small detaching/debonding areas on the base of Column C (right photo). Photos by Author, 2020.

### Structural Column D

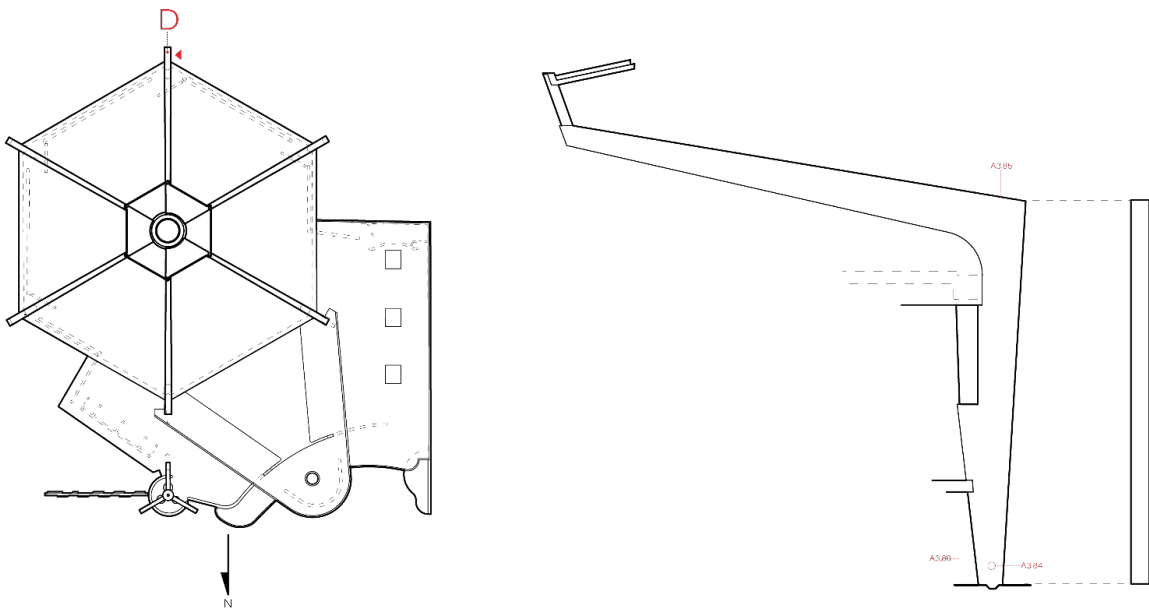


Fig. A2.83 - Structural column D with location of Figures A3.84 – A3.86. Graphics by Author, 2020.





*Fig. A2.84* – Possible alkali-aggregate reaction (AAR) on stucco (as defined by Poole & Sims, 2016) at the base of Column D. Common visual identification of this condition includes crazing surrounded by moisture and discoloration patterns, and efflorescence. Photo by Author, 2020.



*Fig. A2.85 & A2.86* – Fouling, mold growth and scaling of the surfaces along Column D (left photo). The largest detaching/debonding area on a structural column in the Church is seen on the back of Column D Photos by Author, 2020.

## Structural Column E

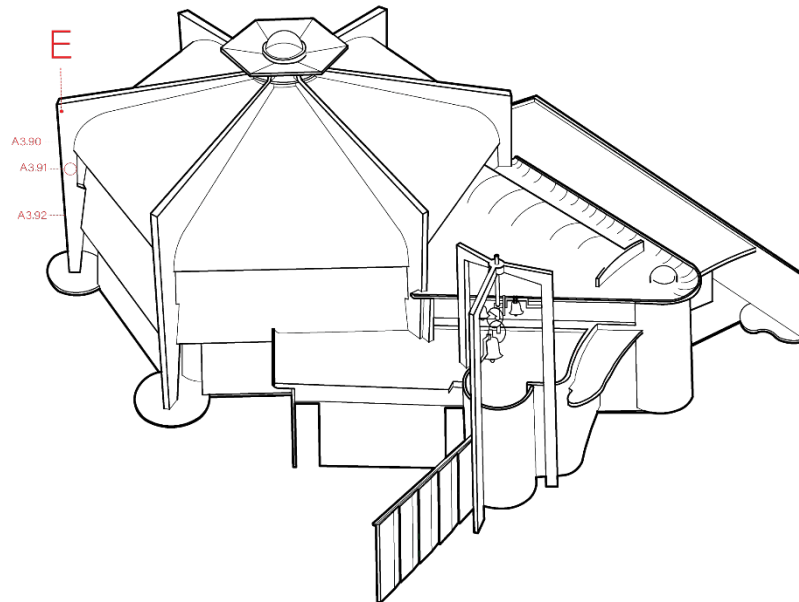


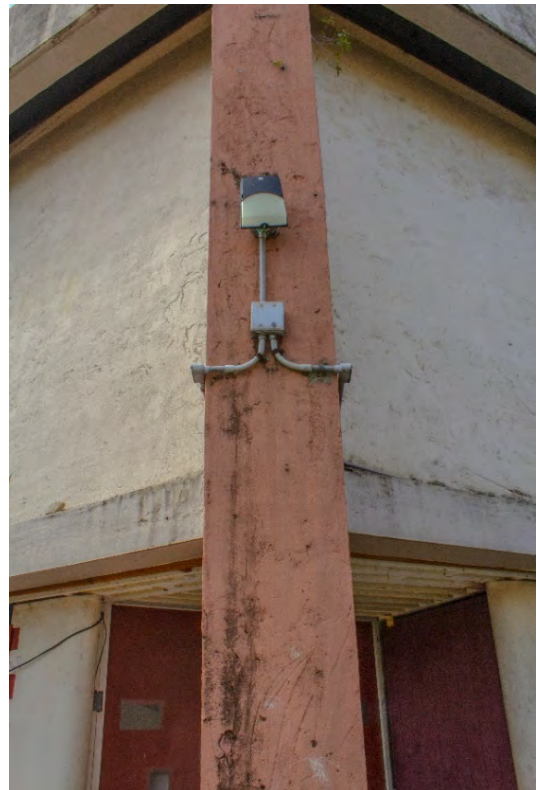
Fig. A2.87 – Structural column E with location of Figures A3.90 – A3.92. Graphics by Author, 2020.



Fig. A2.88 & A2.89 – Trees and vegetation area between Columns E & and Elevation 13 in 2012. Photos by Andrés Rivera, 2012.

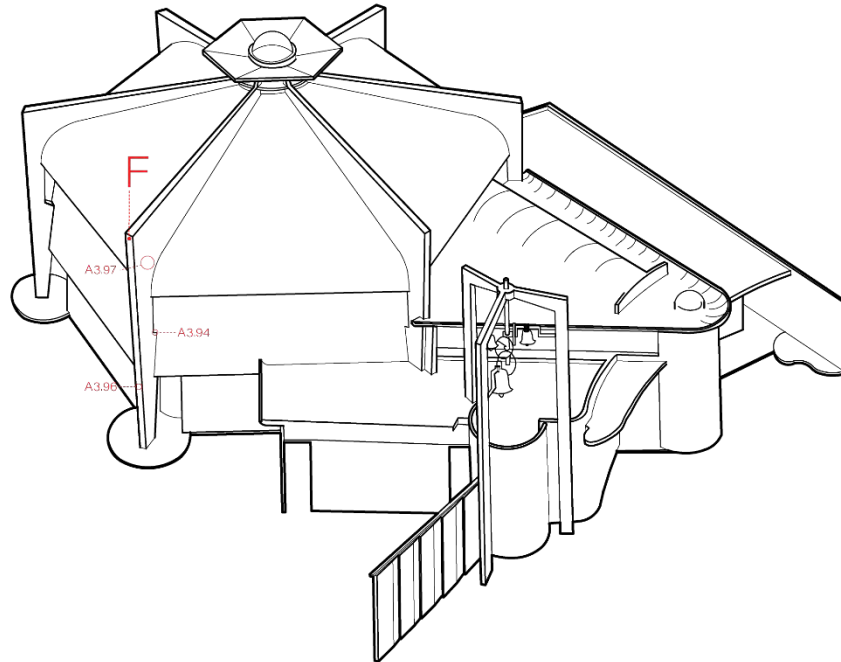


*Fig. A2.90* – Small leafy plants growing along the stuccoed surfaces of Column E. Photos by Author, 2020.



*Figs. A2.91 & A2.92* – Scaling and leafy plants growing on the stucco surfaces of Column E. Lamps have been installed on Columns D, E and F, attaching them to the stuccoed surfaces. Photos by Author, 2020.

## Structural Column F



*Fig. A2.93* – Structural column F with location of Figures A3.94, A3.96 & A3.97. Graphics by Author, 2020.



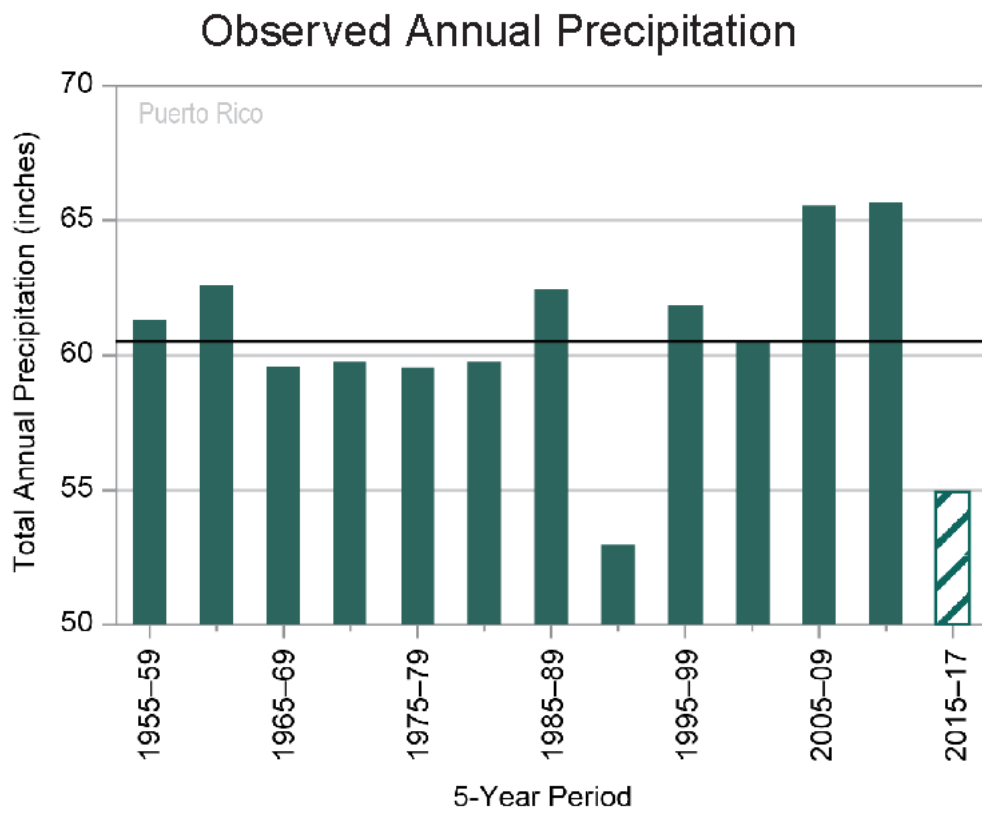
*Fig. A2.94* – The installation of bird spikes with this silicone adhesive was used between the stuccoed surfaces of the tilted walls and columns C, D, E & F. Photo by Author, 2020.



*Fig. A2.95, A2.96 & A2.97 – A failing previous repair behind Column F (top left photo). Fouling, scaling and vertical/horizontal cracking issues on the top of Column F (top right and bottom photos). Photos by Author, 2020.*

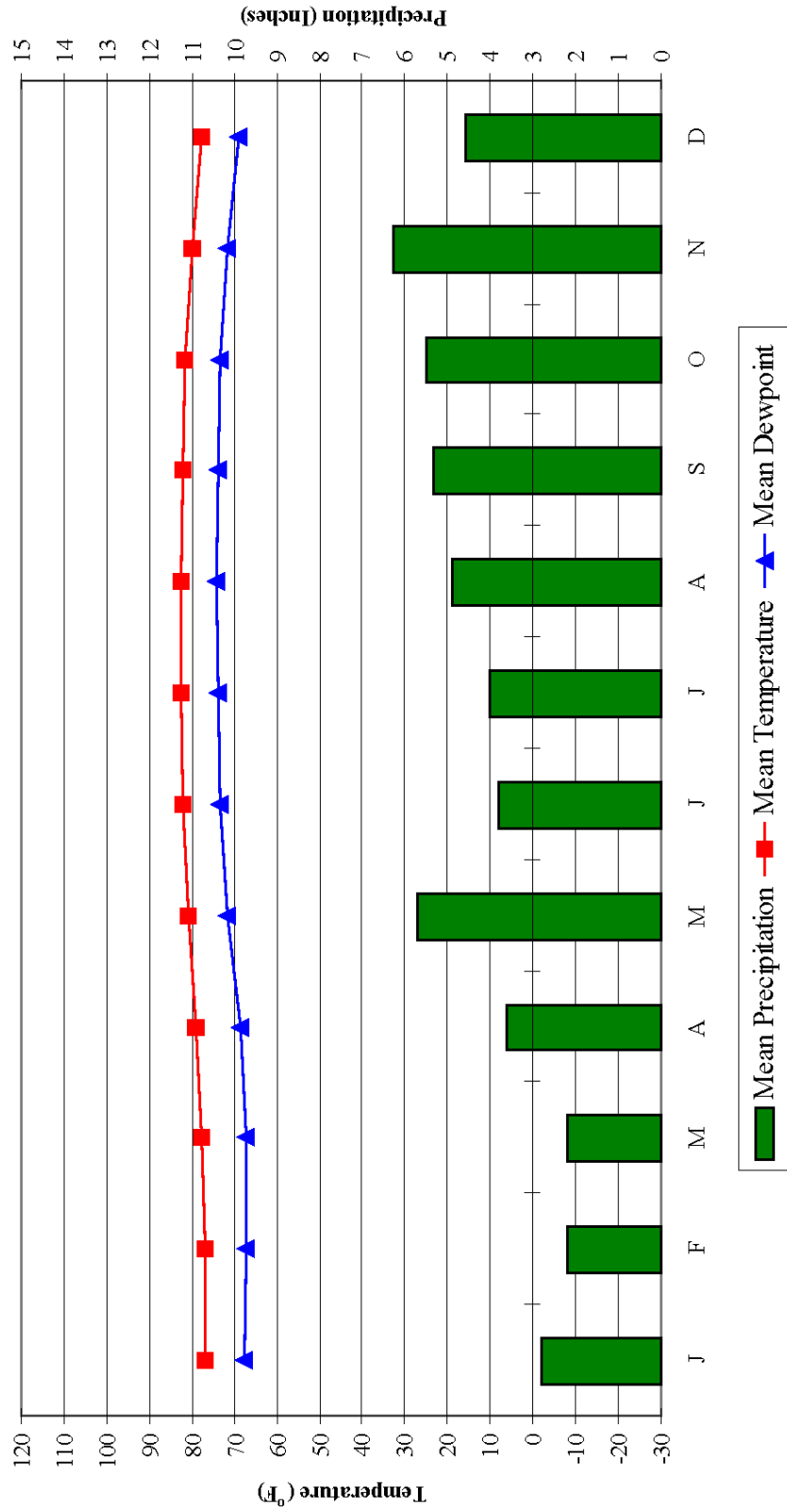
### APPENDIX 3

#### CLIMATE IN SAN JUAN, PUERTO RICO



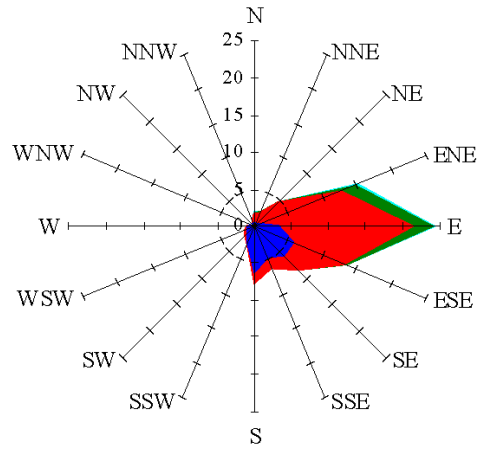
A3.1 - Source: NOAA National Centers for Environmental Information, State Climate Summaries: Puerto Rico / CICS-NC and NOAA NCEI.

Average Annual Climate



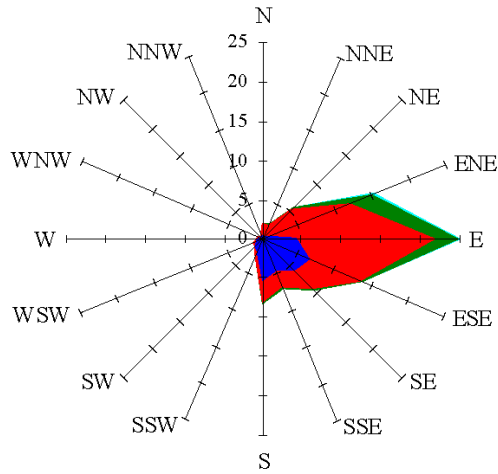
A3.2 - Source: NOAA Climate Data Handbook.

**Wind Summary - December, January, and February**  
**Labels of Percent Frequency on North Axis**



Percent Calm = 9.50

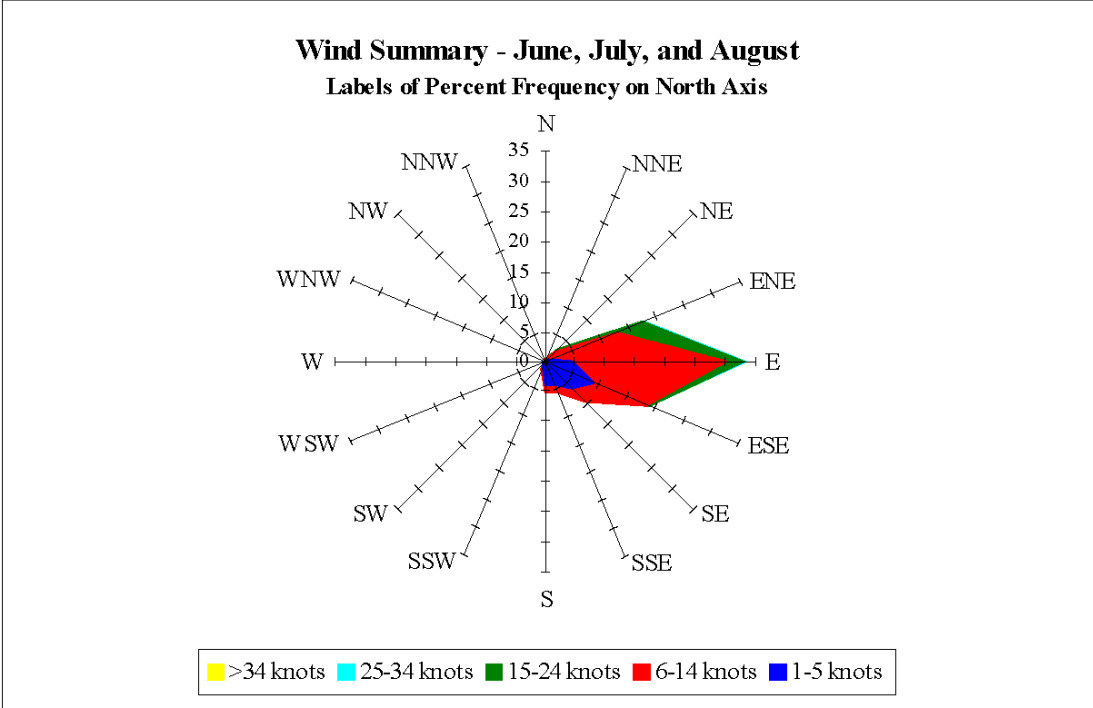
**Wind Summary - March, April, and May**  
**Labels of Percent Frequency on North Axis**



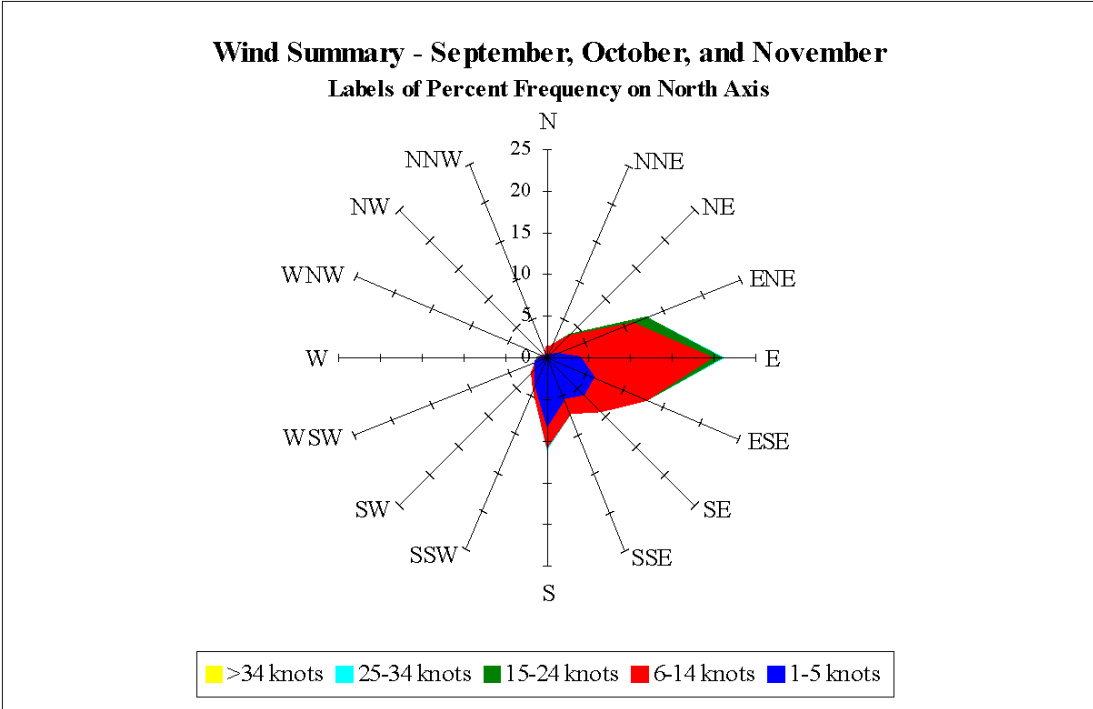
Percent Calm = 6.95

A3.3 - Source: NOAA Climate Data Handbook.





Percent Calm = 4.49



Percent Calm = 9.86

A3.4 - Source: NOAA Climate Data Handbook.



### Average Annual Solar Radiation – Nearest Available Site

(Source: National Renewable Energy Laboratory, Golden CO, 1995)

City: SAN JUAN  
 State: PR  
 WBAN No: 11641  
 Lat(N): 18.43  
 Long(W): 66  
 Elev(ft): 62

Stn Type: Primary  
 SHADING GEOMETRY IN DIMENSIONLESS UNITS  
 Window: 1  
 Overhang: 1.078  
 Vert Gap: 0.2

		AVERAGE INCIDENT SOLAR RADIATION (Btu/sq.ft./day), Percentage Uncertainty = 9												
		Jan	Feb	Mar	Apr	May	Jun	Jul	Aug	Sep	Oct	Nov	Dec	Year
HORIZ	Global	1360	1550	1810	1930	1830	1920	1930	1890	1750	1560	1370	1250	1680
	Std Dev	51	50	77	95	182	127	81	91	91	89	88	65	43
	Minimum	1260	1480	1640	1730	1400	1670	1750	1660	1500	1370	1160	1080	1560
Clear Day	Maximum	1460	1670	1950	2070	2080	2150	2060	2070	1930	1710	1550	1430	1750
	Diffuse	570	640	710	770	850	840	820	800	770	710	610	570	720
	Global	1690	1940	2240	2440	2500	2500	2490	2440	2280	2020	1740	1610	2160
NORTH	Global	360	400	430	490	640	810	740	540	450	410	370	350	500
	Diffuse	360	400	430	470	520	560	540	480	440	410	370	350	440
	Global	320	350	380	450	730	970	870	520	390	360	320	310	500
EAST	Global	770	860	980	1040	990	1030	1010	1010	990	900	780	710	920
	Diffuse	450	500	560	590	600	610	610	600	570	530	470	430	540
	Global	990	1110	1230	1310	1320	1300	1290	1290	1250	1150	1010	950	1180
SOUTH	Global	1350	1230	990	640	480	470	470	530	780	1060	1240	1300	880
	Diffuse	580	580	560	500	470	470	470	480	530	580	580	570	530
	Global	1850	1630	1200	650	410	410	410	500	960	1480	1790	1890	1100
WEST	Global	780	880	980	1000	920	950	970	960	880	820	750	710	880
	Diffuse	450	500	560	590	600	600	600	590	560	520	470	430	540
	Global	990	1110	1230	1310	1320	1300	1290	1290	1250	1150	1010	950	1180

### Average Annual Solar Heat and Illumination – Nearest Available Site

(Source: National Renewable Energy Laboratory, Golden CO, 1995)

		AVERAGE TRANSMITTED SOLAR RADIATION (Btu/sq.ft./day) FOR DOUBLE GLAZING, Percentage Uncertainty = 9												
		Jan	Feb	Mar	Apr	May	Jun	Jul	Aug	Sep	Oct	Nov	Dec	Year
HORIZ	Unshaded	970	1120	1320	1410	1330	1400	1410	1380	1280	1130	980	890	1220
	Shaded	250	270	300	330	390	470	430	350	310	290	260	240	320
NORTH	Unshaded	190	210	240	250	270	300	290	260	240	220	190	180	240
	Shaded	540	610	690	740	700	730	720	720	710	640	550	490	650
EAST	Unshaded	330	370	420	440	410	430	420	420	410	380	330	300	390
	Shaded	960	830	590	380	330	330	330	340	460	690	870	930	590
SOUTH	Unshaded	320	280	280	270	250	260	250	260	270	270	290	330	280
	Shaded	540	620	700	710	650	670	690	680	620	580	530	500	620
WEST	Unshaded	330	370	410	420	380	390	400	400	370	350	320	300	370
	Shaded													

		AVERAGE INCIDENT ILLUMINANCE (klux-hr) FOR MOSTLY CLEAR AND MOSTLY CLOUDY CONDITIONS, Percentage Uncertainty = 9														
		March					June					Dec				
		9am	11am	1pm	3pm	5pm	9am	11am	1pm	3pm	5pm	9am	11am	1pm	3pm	5pm
HORIZ.	M.Clear	40	84	101	86	43	54	92	106	89	49	29	66	78	61	21
	M.Cloudy	30	67	80	68	31	42	72	84	69	35	21	51	62	47	15
NORTH	M.Clear	12	18	18	18	12	31	30	26	30	30	10	16	17	15	8
	M.Cloudy	11	19	20	19	12	24	27	25	27	21	9	17	19	16	7
EAST	M.Clear	70	67	19	18	12	74	62	16	18	14	52	52	17	15	8
	M.Cloudy	40	52	21	19	12	49	49	18	19	13	28	38	19	16	7
SOUTH	M.Clear	24	47	56	48	26	14	18	16	18	14	38	70	79	66	31
	M.Cloudy	17	38	45	39	18	14	19	18	19	13	22	49	58	45	16
WEST	M.Clear	12	18	18	65	72	14	18	19	65	71	10	16	21	56	45
	M.Cloudy	11	19	20	50	39	14	19	20	49	41	9	17	21	39	22
M.Clear (% hrs)	49	43	48	49	51	37	30	29	28	27	40	35	39	40	44	

A3.6 - Source: NOAA Climate Data Handbook.

## **APPENDIX 4**

### **GRILLE CLIMATIQUE**

# PARROQUIA NUESTRA SEÑORA DEL CARMEN, CATAÑO, PR

## MONTHS

FACTORS

368

	JANUARY	FEBRUARY	MARCH	APRIL	MAY	JUNE	JULY	AUGUST	SEPTEMBER	OCTOBER	NOVEMBER	DECEMBER
MAX. MONTHLY TEMPERATURE (°F)	83°F	83°F	84°F	86°F	87°F	88°F	88°F	89°F	89°F	88°F	85°F	83°F
MIN. MONTHLY TEMPERATURE (°F)	72°F	72°F	72°F	74°F	76°F	77°F	78°F	78°F	77°F	76°F	75°F	73°F
WIND SPEED & DIRECTION (mph)	← E 8.3 mph	← E 8.6 mph	← E 9.1 mph	← E 8.8 mph	← E 8.3 mph	← E 8.3 mph	← E 8.9 mph	← E 9.6 mph	↙ E/SE 8.7 mph	↙ E/SE 7.5 mph	↘ E/SE 6.6 mph	← E 7.3 mph
SOLAR RADIATION (Btu/ft <sup>2</sup> -day)	1360	1550	1810	1930	1830	1920	1930	1890	1750	1560	1370	1250
AVERAGE MONTHLY PRECIPITATION (inches)	4.88"	3.27"	2.58"	6.4"	7.5"	3.78"	6.97"	6.83"	5.96"	5.81"	6.94"	6.84"
RELATIVE HUMIDITY	65%	63%	61%	62%	66%	65%	67%	67%	67%	67%	68%	67%
FLOWS	<ul style="list-style-type: none"> <li>- LOW SOLAR RADIATION</li> <li>- RAIN</li> <li>- RAINWATER FLOWS</li> <li>- WATER SPLASH</li> <li>- MOISTURE IN WALL</li> </ul>	<ul style="list-style-type: none"> <li>- SOLAR RADIATION</li> <li>- WINDS CONVECTED LOADS</li> </ul>	<ul style="list-style-type: none"> <li>- SOLAR RADIATION</li> <li>- WINDS CONVECTED LOADS</li> </ul>	<ul style="list-style-type: none"> <li>- HIGH SOLAR RADIATION</li> <li>- RAIN</li> <li>- RAINWATER FLOWS</li> <li>- WATER SPLASH</li> <li>- MOISTURE IN WALL</li> <li>- WINDS CONVECTED LOADS</li> </ul>	<ul style="list-style-type: none"> <li>- SOLAR RADIATION</li> <li>- RAIN</li> <li>- RAINWATER FLOWS</li> <li>- WATER SPLASH</li> <li>- MOISTURE IN WALL</li> </ul>	<ul style="list-style-type: none"> <li>- HIGH SOLAR RADIATION</li> <li>- WINDS CONVECTED LOADS</li> </ul>	<ul style="list-style-type: none"> <li>- HIGH SOLAR RADIATION</li> <li>- RAIN</li> <li>- RAINWATER FLOWS</li> <li>- WATER SPLASH</li> <li>- MOISTURE IN WALL</li> <li>- WINDS CONVECTED LOADS</li> </ul>	<ul style="list-style-type: none"> <li>- HIGH SOLAR RADIATION</li> <li>- RAIN</li> <li>- RAINWATER FLOWS</li> <li>- WATER SPLASH</li> <li>- MOISTURE IN WALL</li> <li>- WINDS CONVECTED LOADS</li> </ul>	<ul style="list-style-type: none"> <li>- SOLAR RADIATION</li> <li>- RAIN</li> <li>- RAINWATER FLOWS</li> <li>- WATER SPLASH</li> <li>- MOISTURE IN WALL</li> </ul>	<ul style="list-style-type: none"> <li>- SOLAR RADIATION</li> <li>- RAIN</li> <li>- RAINWATER FLOWS</li> <li>- WATER SPLASH</li> <li>- MOISTURE IN WALL</li> </ul>	<ul style="list-style-type: none"> <li>- LOW SOLAR RADIATION</li> <li>- RAIN</li> <li>- RAINWATER FLOWS</li> <li>- WATER SPLASH</li> <li>- MOISTURE IN WALL</li> </ul>	<ul style="list-style-type: none"> <li>- LOW SOLAR RADIATION</li> <li>- RAIN</li> <li>- RAINWATER FLOWS</li> <li>- WATER SPLASH</li> <li>- MOISTURE IN WALL</li> </ul>

\*DATA FROM LUIS MUÑOZ MARIN INTERNATIONAL AIRPORT STATION, SAN JUAN

## APPENDIX 5

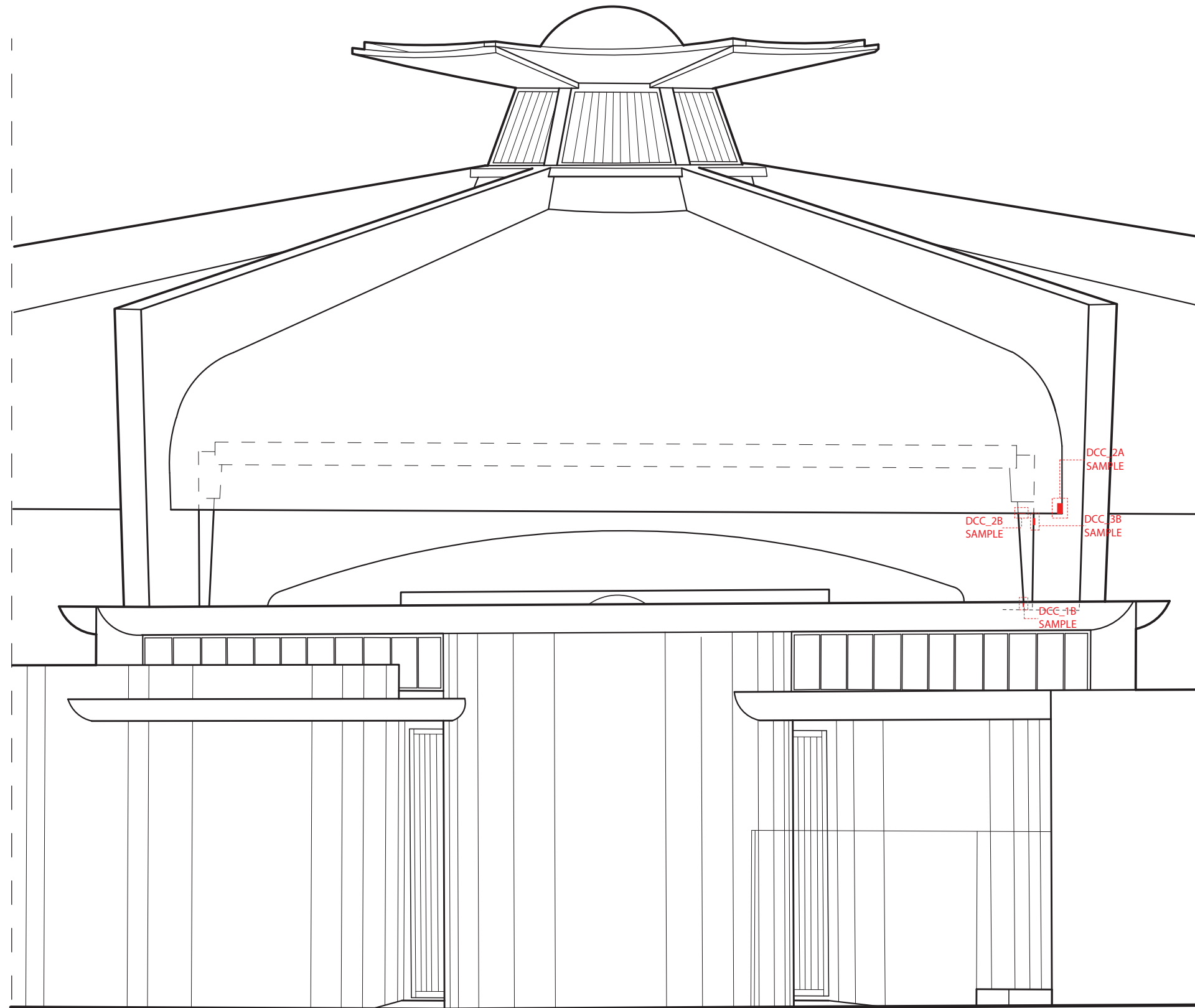
Table A5.1 – Total Collected Samples

SAMPLE ID	SAMPLE LOCATION	TYPE	DATE/TIME SAMPLED	SAMPLED BY	TEST(S) PERFORMED
DCC_1A-1	Elevation 16	Stucco	Jan 10 <sup>th</sup> ,2020 2 pm	HJBH	Reflected light microscopy PLM - Petrography X-Ray Diffraction (XRD) Salts Strips Carbonation – Phenolphthalein
DCC_1A-2	Elevation 16	Stucco	Jan 10 <sup>th</sup> ,2020 2 pm	HJBH	Micro drop Absorption X-Ray Diffraction (XRD)
DCC_1A-3	Elevation 16	Stucco	Jan 10 <sup>th</sup> ,2020 2 pm	HJBH	Reflected light microscopy PLM - Petrography X-Ray Diffraction (XRD) Micro drop Absorption
DCC_1A-4	Elevation 16	Stucco	Jan 10 <sup>th</sup> ,2020 2 pm	HJBH	Salts Strips X-Ray Diffraction (XRD)
DCC_1A-5	Elevation 16	Stucco	Jan 10 <sup>th</sup> ,2020 2 pm	HJBH	Reflected light microscopy PLM - Petrography Micro drop Absorption Salts Strips
DCC_1B	Elevation 16, Near Column B	Stucco + Concrete poured-in-place Substrate	Jan 12 <sup>th</sup> ,2020 4:15 pm	HJBH	Reflected light microscopy PLM - Petrography X-Ray Diffraction (XRD) Micro drop Absorption Salts Strips Carbonation – Phenolphthalein
DCC_2A-1	Cupola, Elevation 8	Stucco + Concrete poured-in-place Substrate	Jan 12 <sup>th</sup> ,2020 4:00 pm	HJBH	Reflected light microscopy PLM - Petrography Micro drop Absorption Salts Strips Microchemical Spot Testing SEM-EDS

DCC_2A-2	Cupola, Elevation 8	Stucco + Concrete poured- in-place Substrate	Jan 12 <sup>th</sup> ,2020 4:00 pm	HJBH	Reflected light microscopy PLM - Petrography Micro drop Absorption Salts Strips Carbonation – Phenolphthalein
DDC_2A-3	Cupola, Elevation 8	Stucco + Concrete poured- in-place Substrate	Jan 12 <sup>th</sup> ,2020 4:00 pm	HJBH	Reflected light microscopy PLM - Petrography X-Ray Diffraction (XRD) Micro drop Absorption
DDC_2A-4	Cupola, Elevation 8	Stucco + Concrete poured- in-place Substrate	Jan 12 <sup>th</sup> ,2020 4:00 pm	HJBH	Salts Strips Microchemical Spot Testing X-Ray Diffraction (XRD)
DDC_2A-5	Cupola, Elevation 8	Stucco + Concrete poured- in-place Substrate	Jan 12 <sup>th</sup> ,2020 4:00 pm	HJBH	Salts Strips X-Ray Diffraction (XRD)
DCC_2B	Cupola- rear, Elevation 8	Stucco + Concrete poured- in-place Substrate	Jan 12 <sup>th</sup> ,2020 4:05 pm	HJBH	Reflected light microscopy PLM - Petrography X-Ray Diffraction (XRD) Salts Strips Carbonation – Phenolphthalein
DCC_3A	Column B- front	Stucco	Jan 12 <sup>th</sup> ,2020 4:20 pm	HJBH	Reflected light microscopy PLM - Petrography X-Ray Diffraction (XRD) Salts Strips Carbonation – Phenolphthalein SEM-EDS
DCC_3B	Column B- rear	Stucco	Jan 12 <sup>th</sup> ,2020 4:30 pm	HJBH	Reflected light microscopy PLM - Petrography X-Ray Diffraction (XRD) Salts Strips Carbonation – Phenolphthalein

DCC_4-1	Circular concrete block wall-rear, Elevation 3B	Stucco	Jan 14 <sup>th</sup> ,2020 1:18 pm	HJBH	Reflected light microscopy PLM - Petrography X-Ray Diffraction (XRD) Micro drop Absorption Salts Strips
DCC_4-2	Circular concrete block wall-rear, Elevation 3B	Stucco	Jan 14 <sup>th</sup> ,2020 1:18 pm	HJBH	Salts Strips X-Ray Diffraction (XRD)
DCC_4-3	Circular concrete block wall-rear, Elevation 3B	Stucco	Jan 14 <sup>th</sup> ,2020 1:18 pm	HJBH	Carbonation – Phenolphthalein X-Ray Diffraction (XRD)
DCC_5	Pre-cast wall-rear, Panel #3 – Elevation 6B	Pre-cast concrete substrate	Jan 14 <sup>th</sup> ,2020 1:07 pm	HJBH	Reflected light microscopy PLM - Petrography X-Ray Diffraction (XRD) Micro drop Absorption Salts Strips Carbonation – Phenolphthalein





8A - NORTHWEST ELEVATION

SCALE 1'-0" = 3/16"



SAMPLES - DCC\_2A  
DCC\_2A-1  
DCC\_2A-2  
DCC\_2A-3



SAMPLE - DCC\_3B

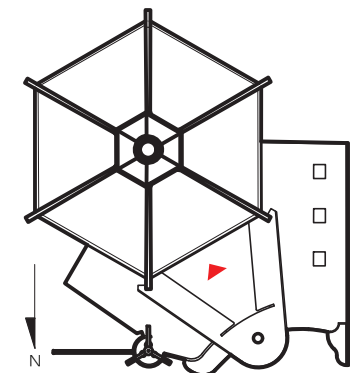


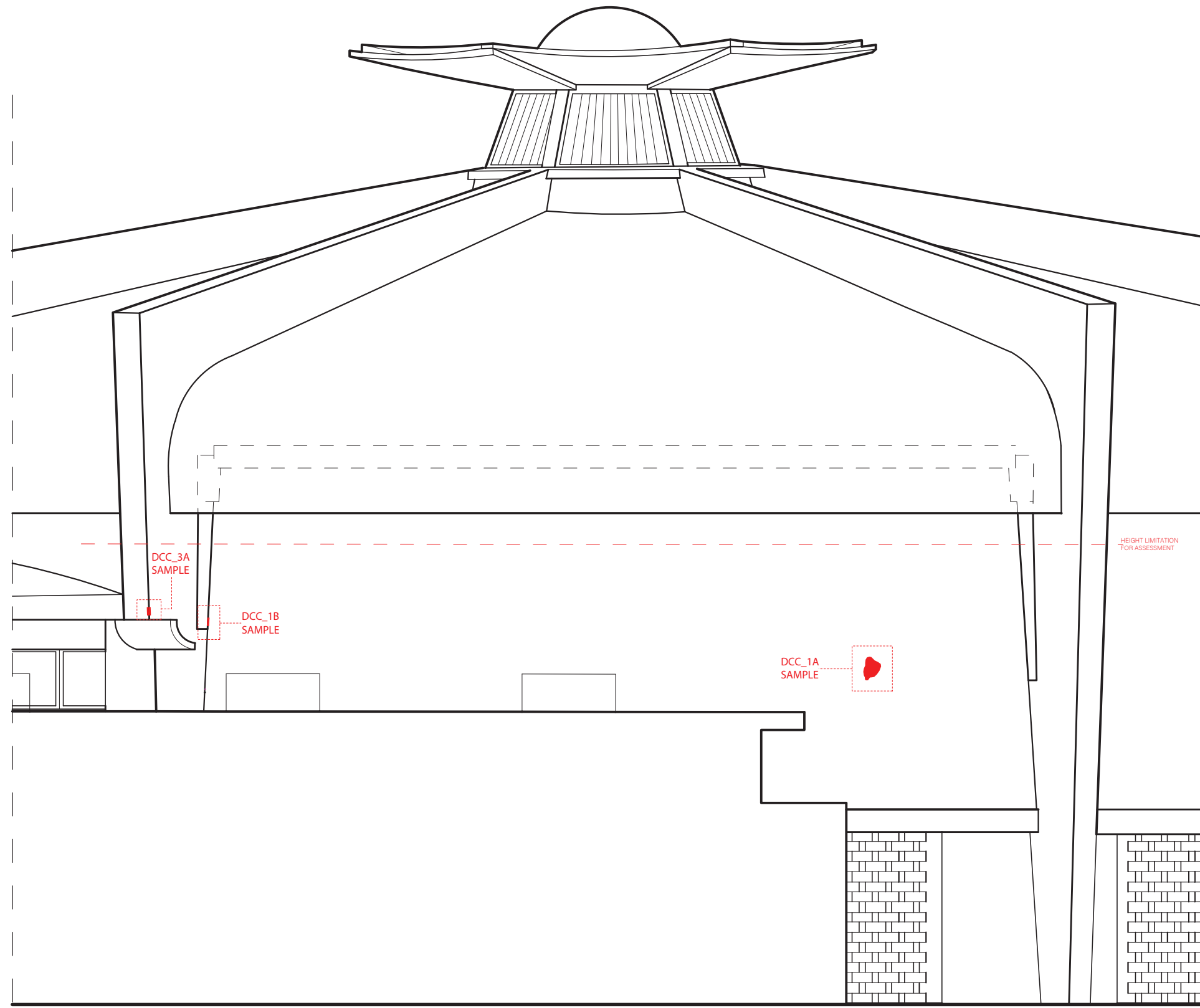
SAMPLE - DCC\_2B



SAMPLE - DCC\_1B

MATERIALS - FINISH & SUBSTRATE: WALL - CAST-IN-PLACE  
PORTLAND CEMENT STUCCO ON WALL





--- SAMPLES - DCC\_1A  
DCC\_1A-1  
DCC\_1A-2  
DCC\_1A-3



--- SAMPLE - DCC\_1B

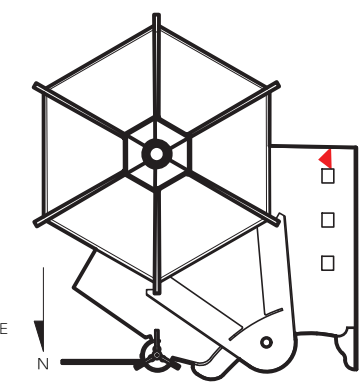


--- SAMPLE - DCC\_3A

16 - WEST ELEVATION  
SCALE 1'-0" = 3/16"



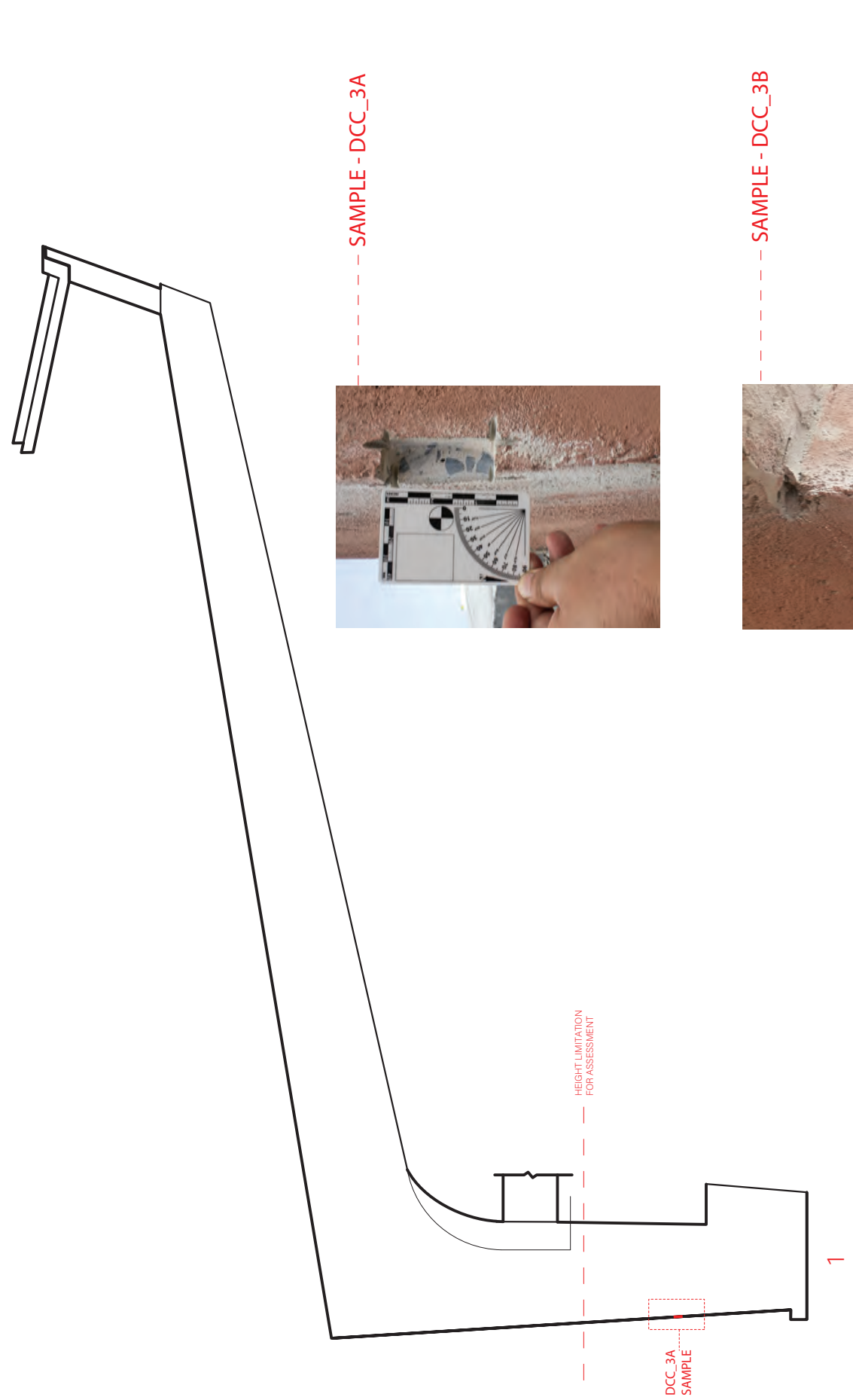
MATERIALS - FINISH & SUBSTRATE: TILTED WALL - CAST-IN-PLACE CONCRETE  
DOME - CAST-IN-PLACE CONCRETE  
PORTLAND CEMENT STUCCO



DRAWN BY: HECTOR J. BERDECIA-HERNANDEZ  
UNIVERSITY OF PENNSYLVANIA  
GRADUATE PROGRAM IN HISTORIC PRESERVATION, SCHOOL OF DESIGN

PARROQUIA NUESTRA SEÑORA DEL CARMEN  
42 CALLE EL TREN, CATAÑO, P.R. 00962

DATE: JAN 2020  
SURVEY NO.  
SAMPLE LOCATIONS  
SHEET 2 OF 5 SHEETS



SAMPLE - DCC\_3A

HEIGHT LIMITATION FOR ASSESSMENT

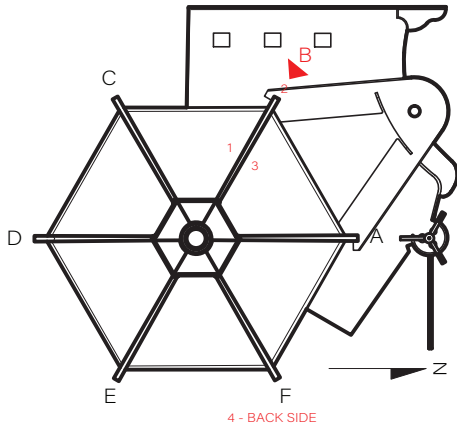
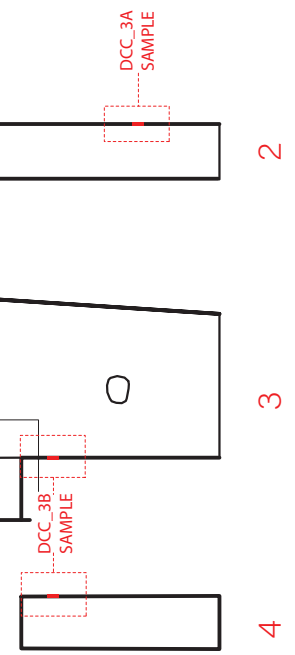
DCC\_3A SAMPLE

1



SAMPLE - DCC\_3B

HEIGHT LIMITATION FOR ASSESSMENT



STRUCTURAL COLUMN B - NORTHWEST SIDE  
 SCALE 1'-0" = 3/16"

MATERIALS - FINISH & SUBSTRATE: CAST-IN-PLACE CONCRETE  
 PORTLAND CEMENT STUCCO



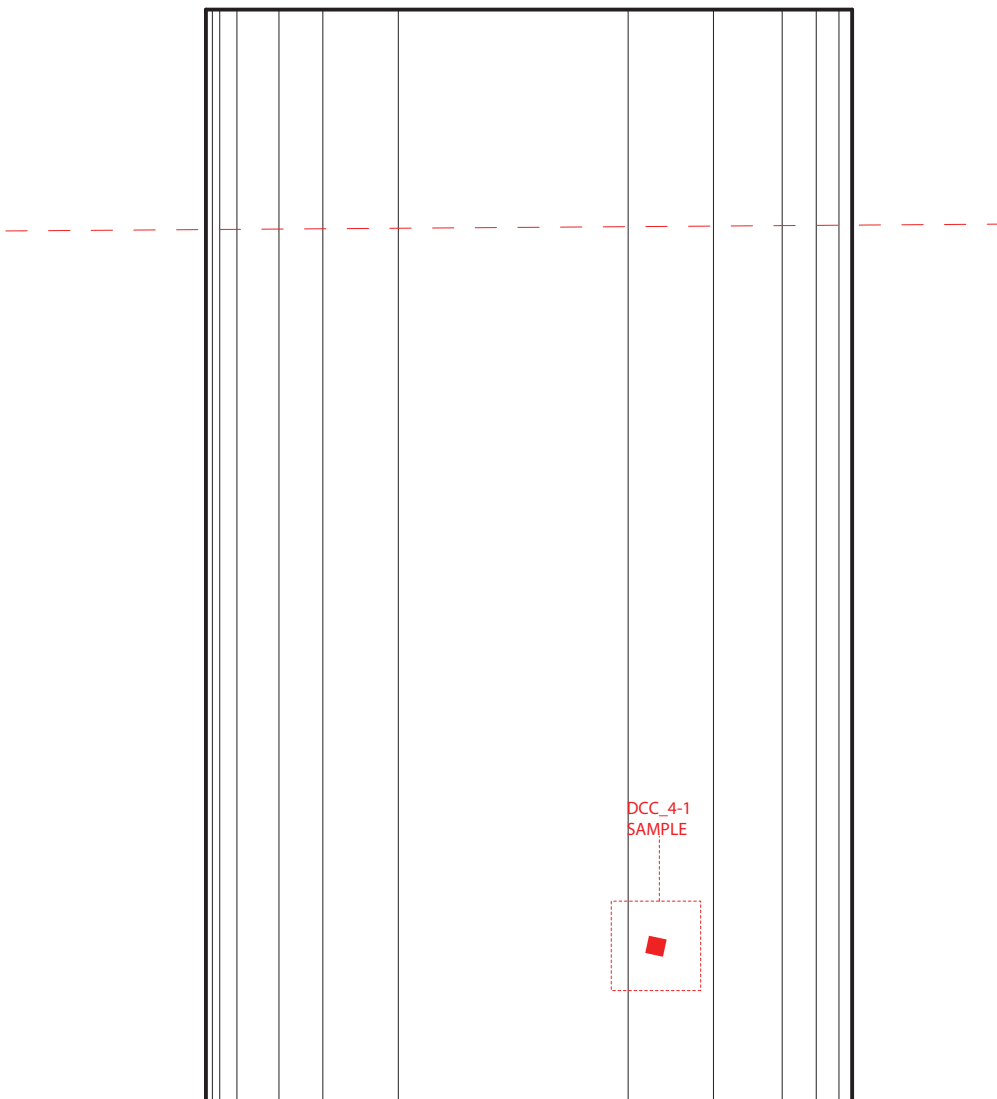
DRAWN BY: HECTOR J. BERDECIA-HERNANDEZ

UNIVERSITY OF PENNSYLVANIA  
 GRADUATE PROGRAM IN HISTORIC PRESERVATION, SCHOOL OF DESIGN

PARROQUIA NUESTRA SEÑORA DEL CARMEN  
 42 CALLE EL TREN, CATAÑO, PR, 00982

SURVEY NO.  
 SAMPLE LOCATIONS  
 SHEET 3 OF 5

DATE  
 JAN 2020



SIDE A

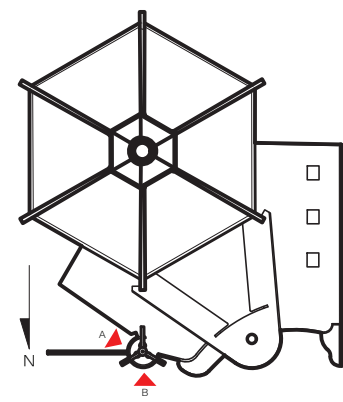
### 3 - BAPTISTRY - CIRCULAR WALL ON NORTHWEST ELEVATION

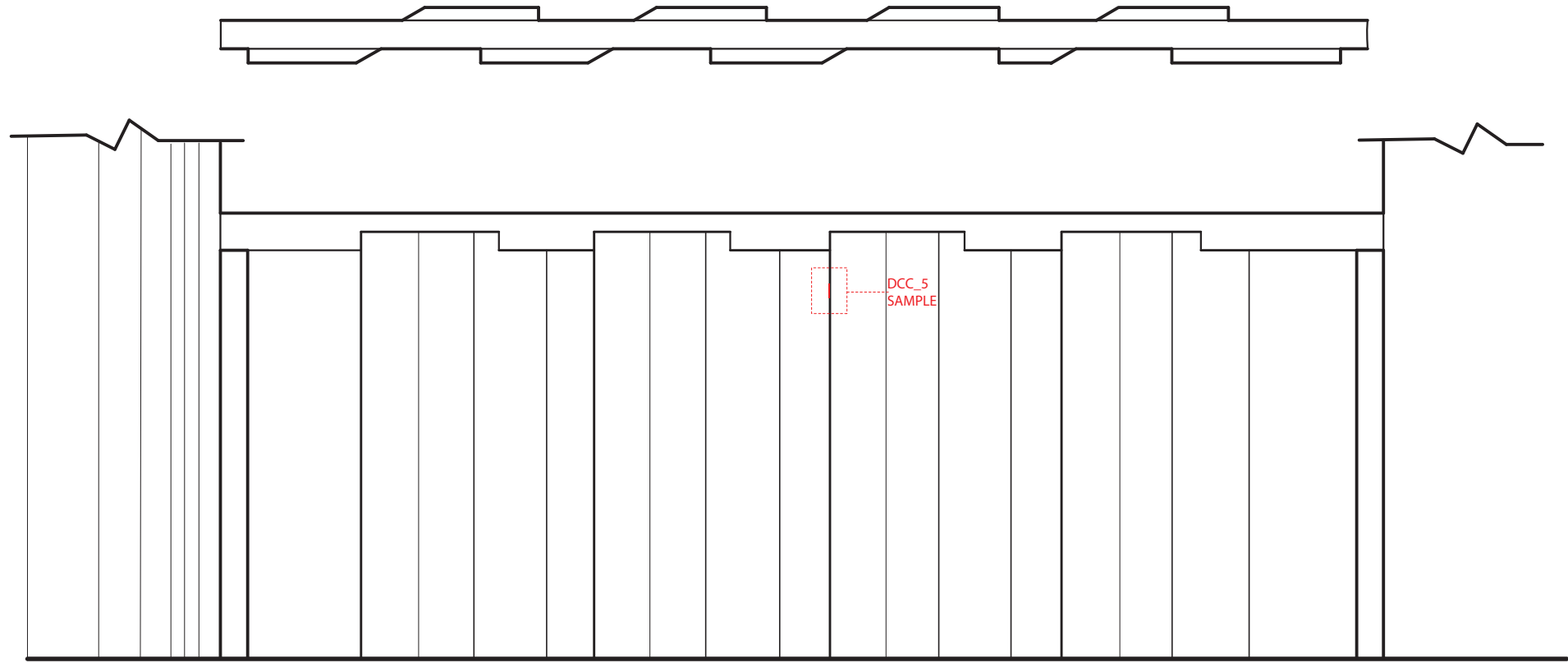
SCALE 1'-0" = 3/8"



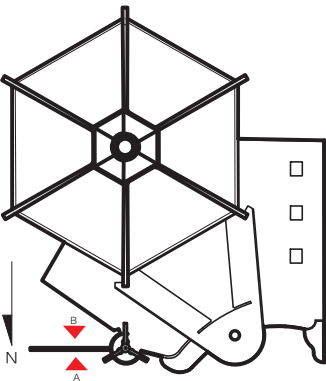
----- SAMPLE - DCC\_4-1

MATERIALS - FINISH & SUBSTRATE: WALL - REINFORCED CONCRETE BLOCKS  
PORTLAND CEMENT STUCCO ON WALL





SAMPLE - DCC\_5



MATERIALS - FINISH & SUBSTRATE: PRECAST CONCRETE PANELS

SIDE B  
6 - EXTERIOR PRECAST WALL ON NORTHEAST ELEVATION  
SCALE 1'-0" = 3/8"



## APPENDIX 6 - SAMPLES



SAMPLE 1A-1



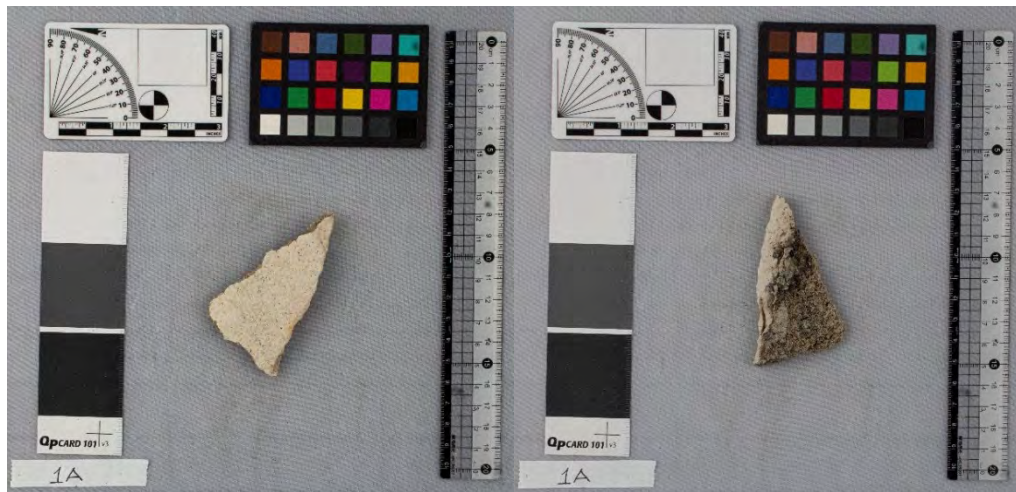
SAMPLE 1A-2



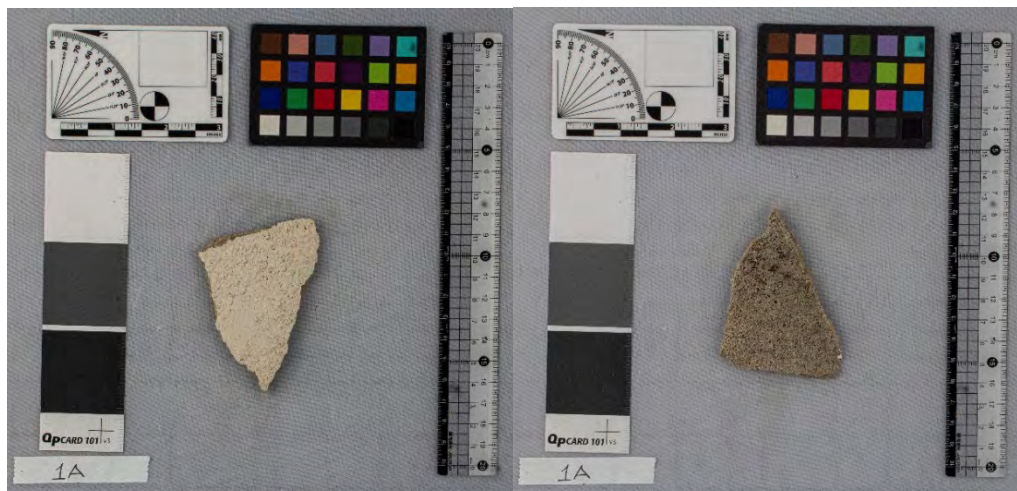
SAMPLE 1A-3



SAMPLE 1A-4



SAMPLE 1A-5



SAMPLE 1A-6



SAMPLE 1A-7



SAMPLE 1B



SAMPLE 2A-1





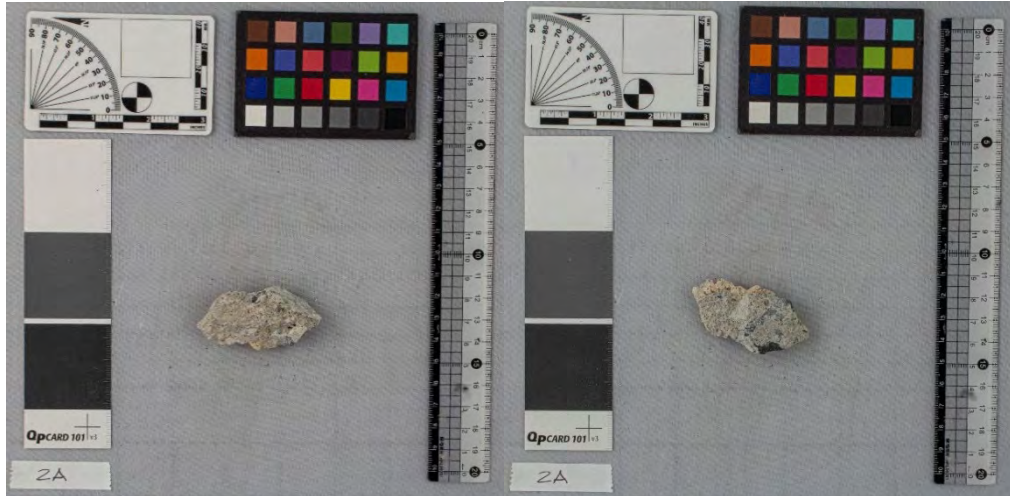
SAMPLE 2A-2



SAMPLE 2A-3



SAMPLE 2A-4



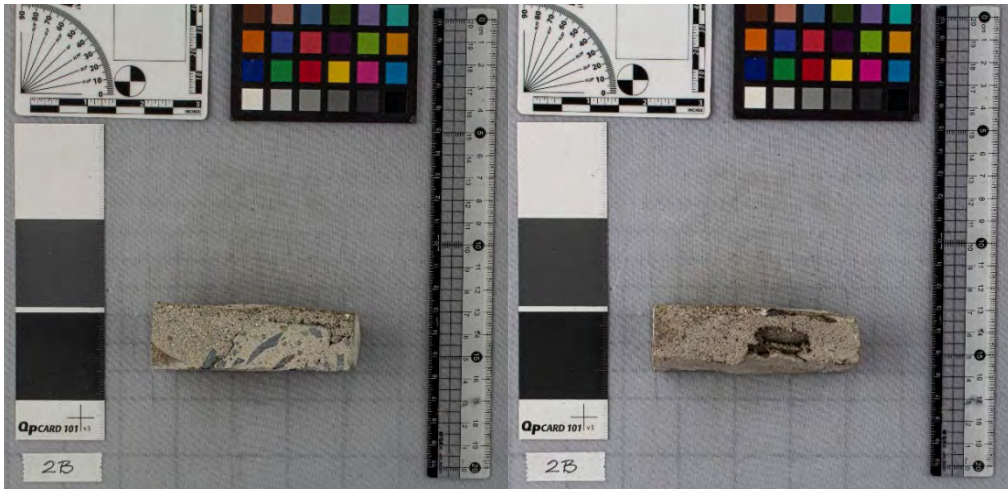
SAMPLE 2A-5



SAMPLE 2A-6



SAMPLE 2A-7



SAMPLE 2B



SAMPLE 3A



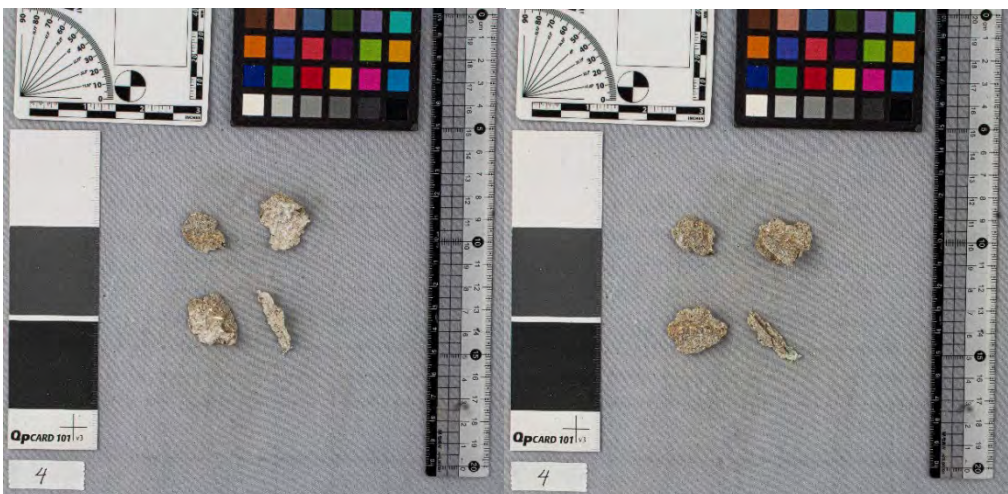
SAMPLE 3B



SAMPLE 4-1



SAMPLE 4-2



SAMPLE 4-3



SAMPLE 5

## APPENDIX 7

Table A7.1 – Testing Matrix

Property	Instrumental Analysis	References	Preparation/ Equipment	Test Location	Total Samples per Test	Test Period
Characterization	<i>Stereomicroscopy</i>		Leica MZ16a Microscope	ACL	17	1-26-20 (1 day)
Carbonation	<i>Carbonation – Phenolphthalein</i>	English Heritage – Concrete p. 122  English Heritage – Mortars, Renders and Plasters, p. 214  ICCROM Laboratory Manual for Architectural Conservation	Zeiss Axioscope A1	On-Site Del Carmen Church	8	1-12-20 1-14-20 (2 days)
Salts	<i>Semi-Quantitative Salt Analysis</i>	Instructions from Manufacturer  Casey Weisdock Thesis Sarah Stratte Thesis Kevin Wohlgemuth Thesis  English Heritage – Mortars, Renders and Plasters, p. 219	Testing Strips	CAC	8	8-30-20 (1 day)

Water Absorption	<i>Micro-drop absorption test</i>	Jose Delgado Rodrigues' work	Deionized Water	CAC	7 (1A, 1B, 2A, 2B, 3A, 4 & 5)	8-20-20 (1 day)
Composition	<i>Micro-chemical spot test</i>	Identifying Architectural Metals – Microchemical Spot Tests Lab – HSPV 555  Odegaard, Nancy. Materials Characterization Tests for Works of Art. Archetype Books, 2005. (2 <sup>nd</sup> edition).  Lauren Vollono Drapala Thesis	Different Reagents / Ceramic Spot Test Plates	CAC	1 (2A)	8-20-20 (1 day)

Characterization	<i>Polarized Light Microscopy (PLM)/ Petrography</i>	<p>ASTM C295 - Petrographic Examination of Aggregates for Concrete</p> <p>ASTM C856 – Petrographic Examination of Hardened Concrete</p> <p>ASTM C1324 - Examination and Analysis of Hardened Masonry Mortar</p> <p>ASTM C457 - Microscopical Determination of Parameters of the Air-Void System in Hardened Concrete</p> <p>STP1061 – Petrography Applied to Concrete and Concrete Aggregates</p> <p>SPT1613 – Advances in Cement Analysis and Concrete Petrography</p> <p>ASTM C1721 - Petrographic Examination of Dimension Stone</p> <p>Concrete Petrography – Past, Present &amp; Future Dipayana Jana (2005)</p>	Zeiss Axioscope A1	CAAM	12 (1A-1, 1A-3, 1A-5, 1B, 2A-1, 2A-2, 2A-3, 2B, 3A, 3B, 4-1, 5)	Between 7-29-20 to 8-19-20 (11 days)
------------------	--	---	--------------------	------	--	--------------------------------------



		<p>John J. Walsh.  Petrography:  Distinguishing Natural  Cement from Other  Binders in Historical  Masonry Construction  Using Forensic  Microscopy Techniques.  Journal of ASTM  International. Vol. 4,  No. 1.</p> <p>Poole &amp; Sims. <i>Concrete  Petrography: A  Handbook of  Investigative  Techniques</i>, 2<sup>nd</sup> Ed.  (2012)</p> <p>Ingham, J. <i>Geomaterials  Under the Microscope</i>  (2013)</p> <hr/> <p>Theses:  Richard M.P. Lowry  (Columbia GSAPP)  Julianne Wiesner  Sarah Stratte  Irene Matteini</p>				
--	--	---	--	--	--	--

Salts & Composition	<i>X-Ray Powder Diffraction Spectrometry (XRD)</i>	Literature from the Internet  Casey Weisdock Thesis Lauren Vollono Drapala Thesis	Rigaku MiniFlex 6G theta-2theta vertical goniometer benchtop powder diffraction system (machine) and Computer	LRSM	8	8-27-28 8-28-20 8-31-20 (3 days)
Composition	<i>Scanning Electron Microscopy - Energy Dispersive X-Ray Spectroscopy (SEM-EDS)</i>	Literature from the Internet  Julianne Wiesner-Chianese Thesis Lauren Vollono Drapala Thesis Araba Prah Thesis Irene Matteini Thesis  ASTM 1723 - Examination of Hardened Concrete Using	FEI Quanta 600 FEG Mark II Environmental Scanning Electron Microscope	LRSM	2 (2A & 3A)	8-7-20 9-8-20 (2 days)

## APPENDIX 8

### STEREOMICROSCOPE

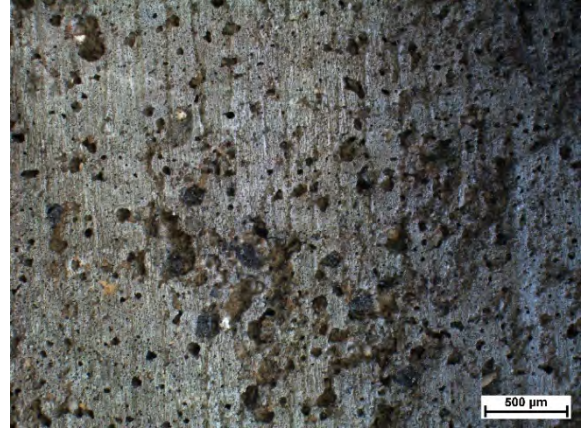
*Table A8.1 – Stereomicroscope observations*

Samples	Observations	Selected for Thin Sections
Samples 1A		
1A-1	Back surface – Less porous and flat than the front	X
1A-2	Big chunks of lime visible	
1A-3	Shows a non-deteriorated area and deteriorated areas (transition)	X
1A-4	Shows deteriorated areas	
1A-5	Shows deteriorated areas	X
Sample 1B	Shows big stone aggregate Shows clear composition and defined stucco layers	X
Samples 2A		
2A-1	The most complete sample – shows clear composition, layers, and deteriorated areas	X
2A-2	Shows composition and deteriorated areas	X
2A-3	Shows deteriorated/exposed areas	X
2A-4	Shows deteriorated areas	
Sample 2B	The transition between Stucco and concrete substrate difficult to see	X
Sample 3A	Shows deteriorated areas	X
Sample 3B	A visible area with less aggregate – Variations	X
Samples 4		
4-1	Sample - less porous compared to Samples 1A Sandy aggregate visible	X
4-2	Sandy aggregate visible	
4-3	Sandy aggregate visible	
Sample 5	Few pores are seen compared with other samples It is not known if there are any stucco coatings (layers)	X

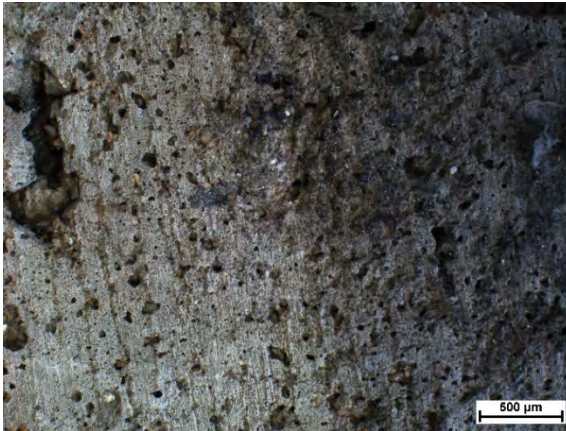
SAMPLE 1A-1



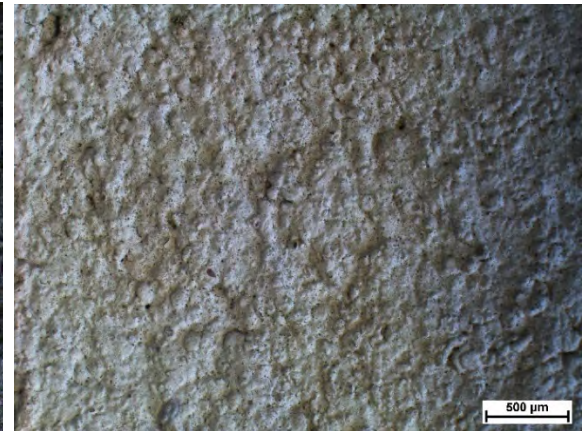
Magnification 1.0x



Magnification 1.0x



Magnification 1.0x

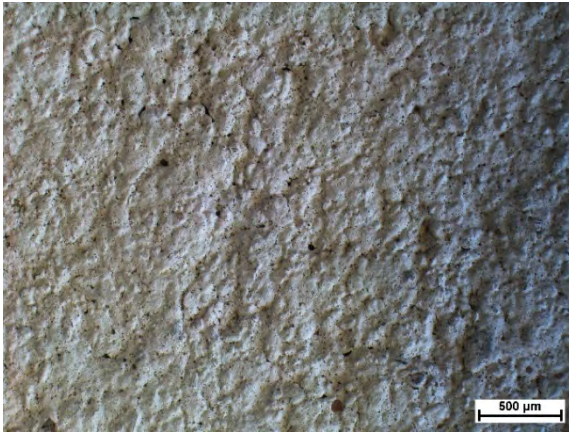


Magnification 1.0x



Magnification 1.25x

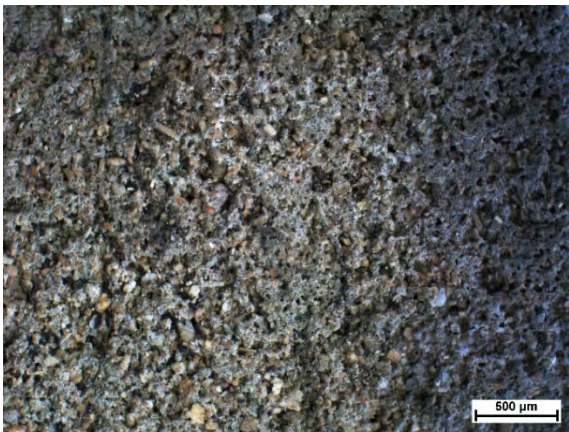
SAMPLE 1A-3



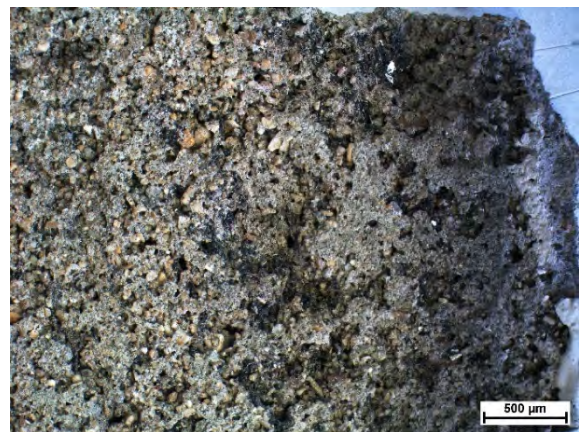
Magnification 1.25x



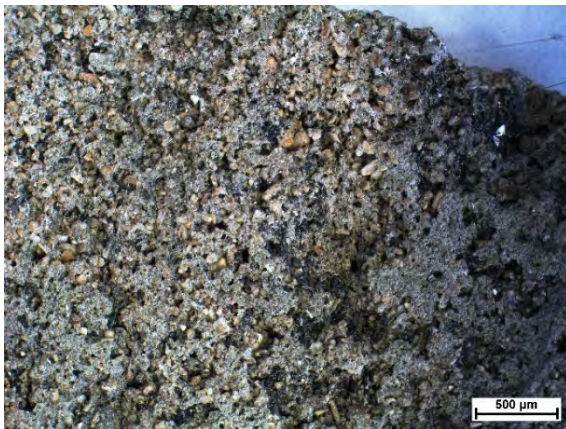
Magnification 1.25x



Magnification 1.0x



Magnification 1.0x



Magnification 1.0x

SAMPLE 1A-5



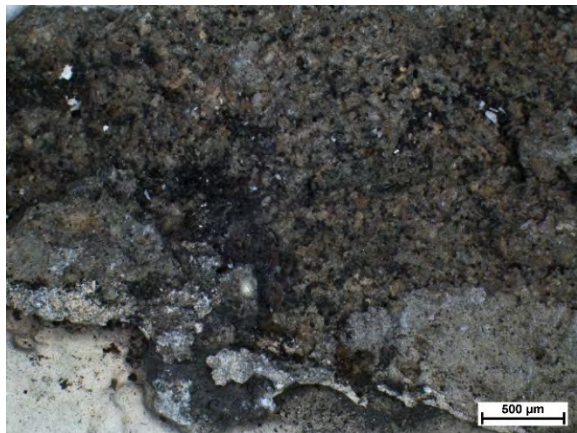
Magnification 1.25x



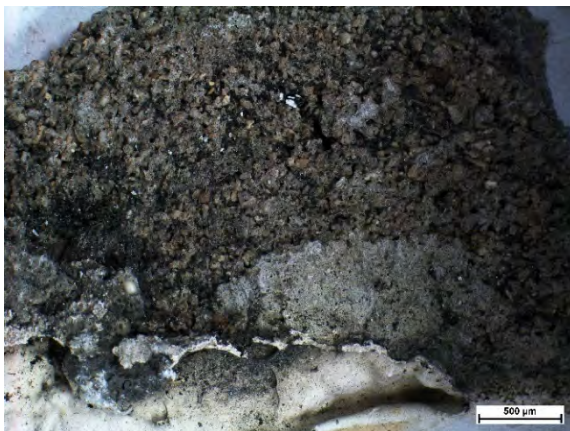
Magnification 1.25x



Magnification 1.0x



Magnification 1.25x



Magnification 1.0x

SAMPLE 1B



Magnification 1.25x



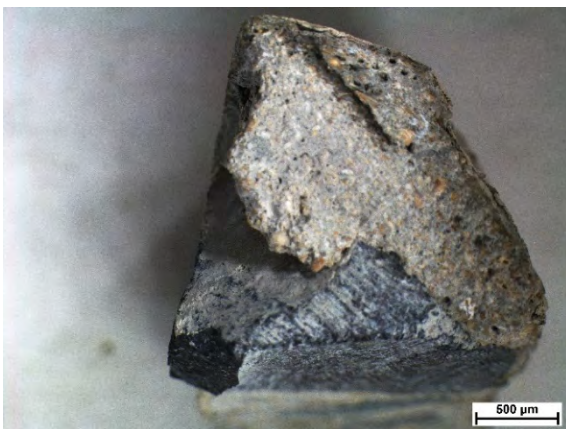
Magnification 1.25x



Magnification 1.0x

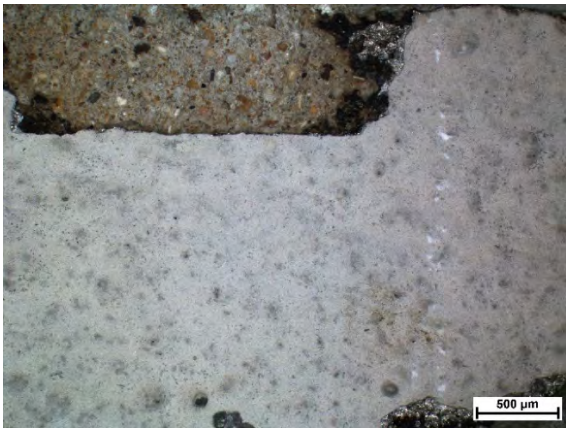


Magnification 1.0x

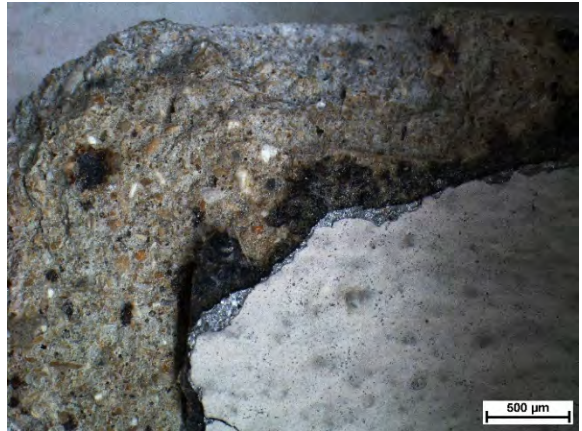


Magnification 1.0x

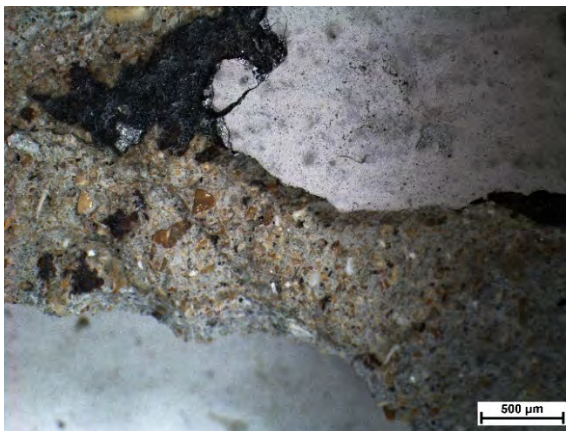
SAMPLE 2A-1



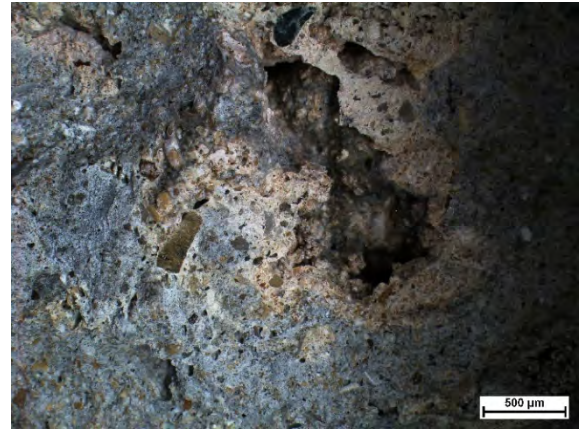
Magnification 1.25x



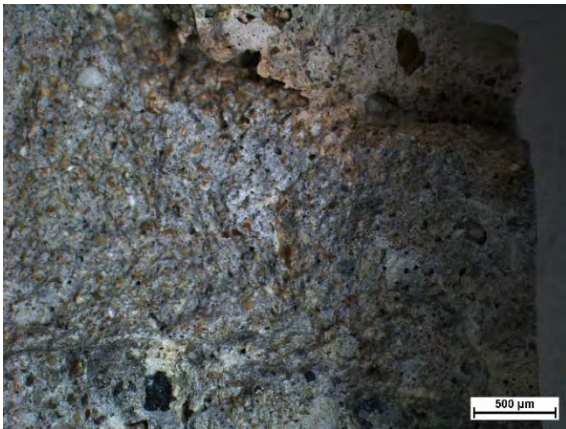
Magnification 1.25x



Magnification 1.25x



Magnification 1.0x



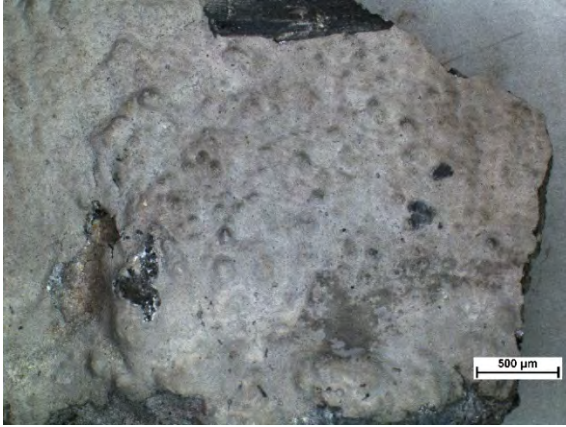
Magnification 1.0x



Magnification 1.0x



SAMPLE 2A-2



Magnification 1.0x



Magnification 1.0x



Magnification 1.0x



Magnification 1.0x

SAMPLE 2A-3



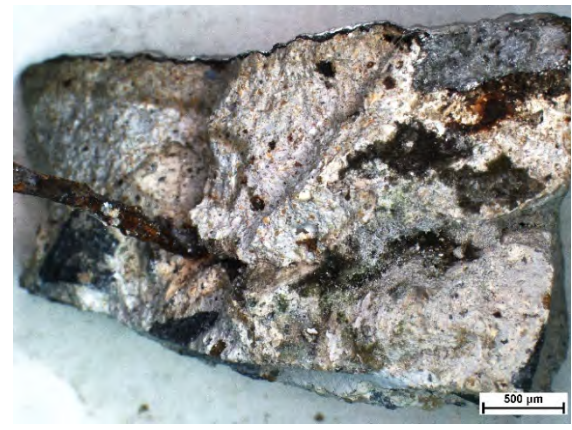
Magnification 1.0x



Magnification 1.0x



Magnification 1.0x



Magnification 1.0x



Magnification 0.71x

SAMPLE 2B



Magnification 1.0x



Magnification 1.0x



Magnification 1.0x



Magnification 1.0x



Magnification 1.0x



Magnification 1.0x

SAMPLE 3A



Magnification 1.0x



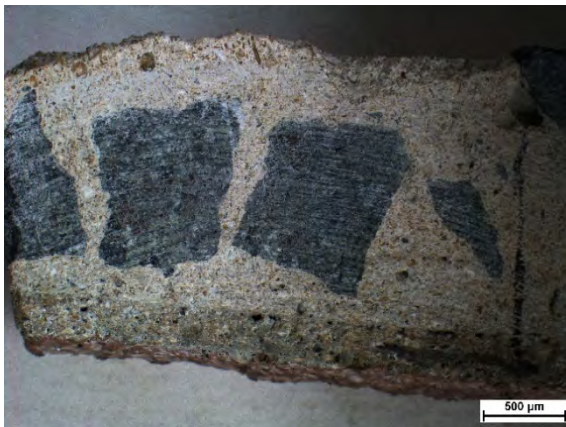
Magnification 1.0x



Magnification 1.0x



Magnification 1.0x

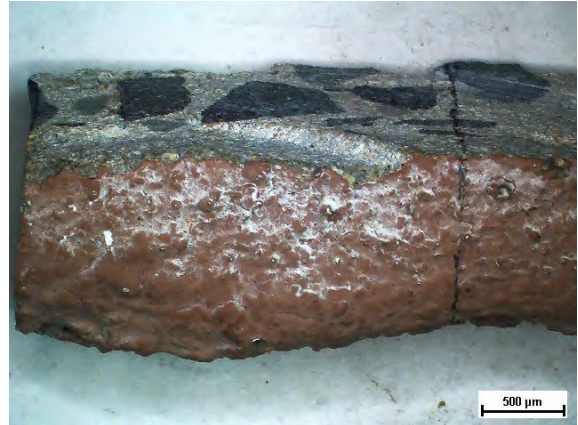


Magnification 1.0x

SAMPLE 3B



Magnification 0.71x



Magnification 0.71x



Magnification 0.71x



Magnification 0.71x



Magnification 0.71x

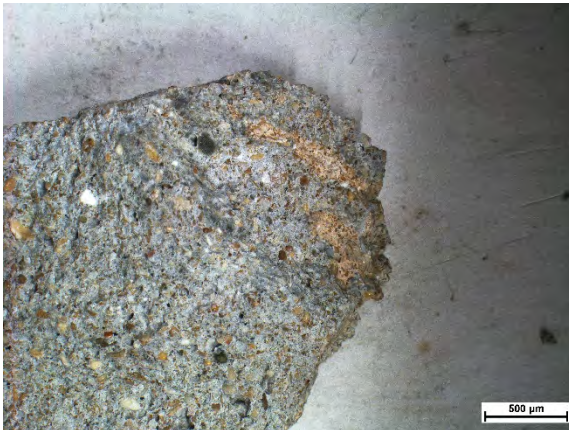
SAMPLE 4-1



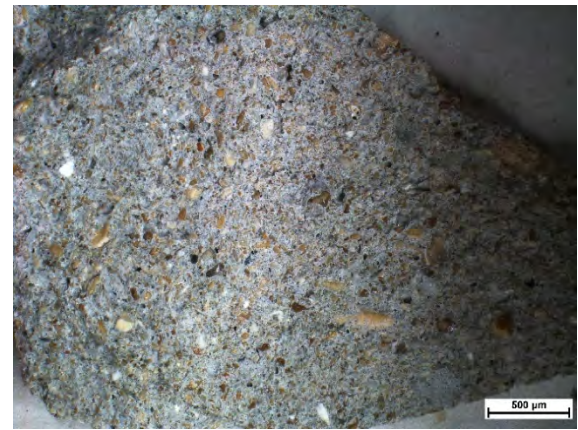
Magnification 1.0x



Magnification 1.0x

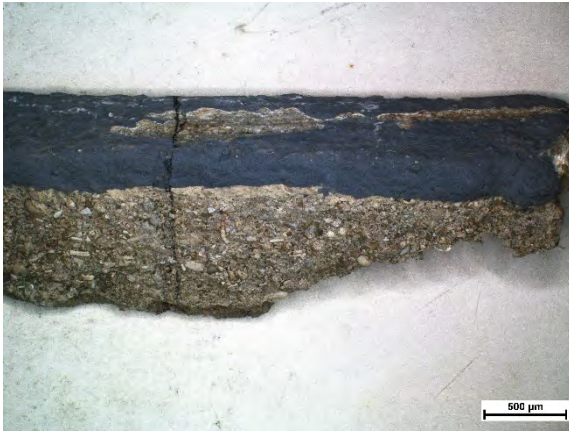


Magnification 1.0x

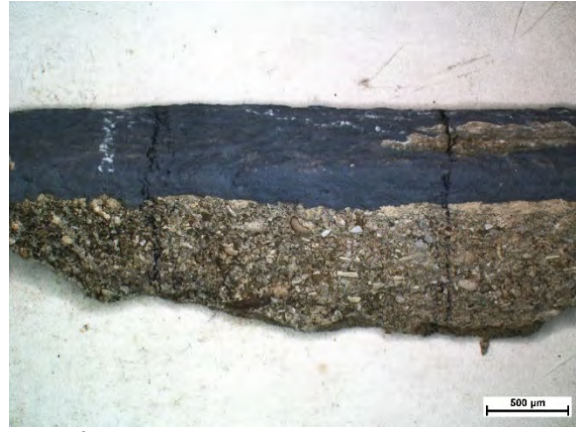


Magnification 1.0x

SAMPLE 5



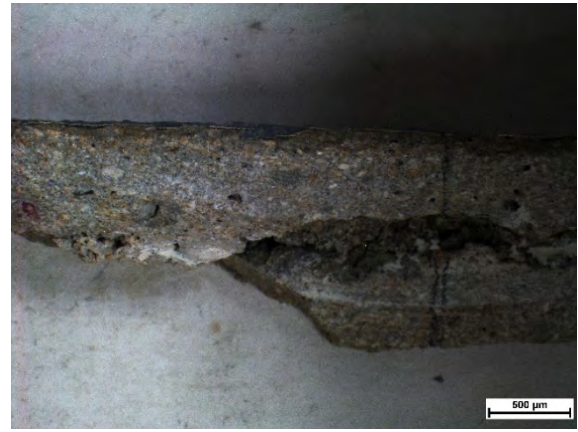
Magnification 0.71x



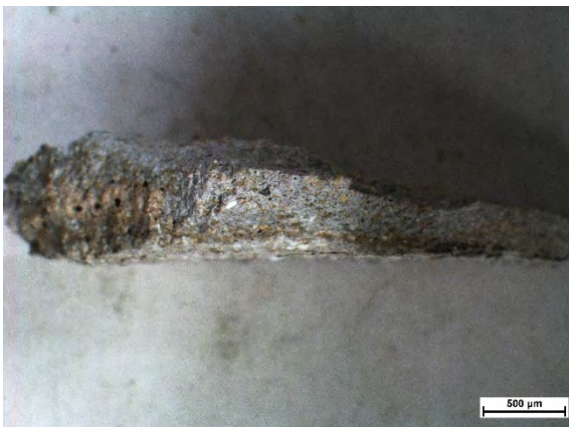
Magnification 0.71x



Magnification 0.71x



Magnification 0.71x



Magnification 0.71x



Magnification 0.71x

## APPENDIX 9

### CARBONATION

*Table A9.1 – Carbonation results*

Sample	Material	Results (Drop appearance)
1A	Sprayed stucco only	Clear – Full Carbonation
1B	Sprayed stucco and concrete substrate	Clear – Full Carbonation
2A	Troweled stucco and concrete substrate	Partial carbonation (Stucco) Substrate- No carbonation
2B	Sprayed stucco and concrete substrate	Clear – Full Carbonation
3A	Sprayed stucco and troweled stucco – 2 coats	Clear – Full Carbonation
3B	Sprayed stucco and troweled stucco – 2 coats	Clear – Full Carbonation
4	Troweled stucco – Concrete masonry wall	No carbonation
5	Concrete substrate – Pre-cast wall	Clear – Full Carbonation

#### SAMPLE 1A



Before the application of Phenolphthalein ( $C_{20}H_{14}O_4$ ) indicator



After the application of Phenolphthalein ( $C_{20}H_{14}O_4$ ) indicator – Results: Clear reaction-Full Carbonation



SAMPLE 1B



Before the application of Phenolphthalein ( $C_{20}H_{14}O_4$ ) indicator



After the application of Phenolphthalein ( $C_{20}H_{14}O_4$ ) indicator – Results: Clear reaction-Full Carbonation

SAMPLE 2A



Before the application of Phenolphthalein ( $C_{20}H_{14}O_4$ ) indicator



After the application of Phenolphthalein ( $C_{20}H_{14}O_4$ ) indicator  
Results: No Carbonation on the Substrate, Partial Carbonation of Stucco

SAMPLE 2B

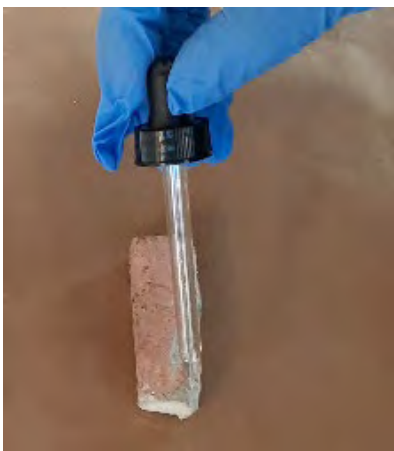


Before the application of Phenolphthalein ( $C_{20}H_{14}O_4$ ) indicator



After the application of Phenolphthalein ( $C_{20}H_{14}O_4$ ) indicator – Results: Clear reaction-Full Carbonation

SAMPLE 3A



Before the application of Phenolphthalein ( $C_{20}H_{14}O_4$ ) indicator



After the application of Phenolphthalein ( $C_{20}H_{14}O_4$ ) indicator – Results: Clear -Full Carbonation

SAMPLE 3B



Before the application of Phenolphthalein ( $C_{20}H_{14}O_4$ ) indicator



After the application of Phenolphthalein ( $C_{20}H_{14}O_4$ ) indicator – Results: Clear reaction-Full Carbonation

SAMPLE 4



Before the application of Phenolphthalein ( $C_{20}H_{14}O_4$ ) indicator.



After the application of Phenolphthalein ( $C_{20}H_{14}O_4$ ) indicator – Results: No Carbonation

SAMPLE 5



Before the application of Phenolphthalein ( $C_{20}H_{14}O_4$ ) indicator.



After the application of Phenolphthalein ( $C_{20}H_{14}O_4$ ) indicator – Results: Clear reaction-Full Carbonation

## APPENDIX 10

### MICRODROP WATER ABSORPTION TESTING

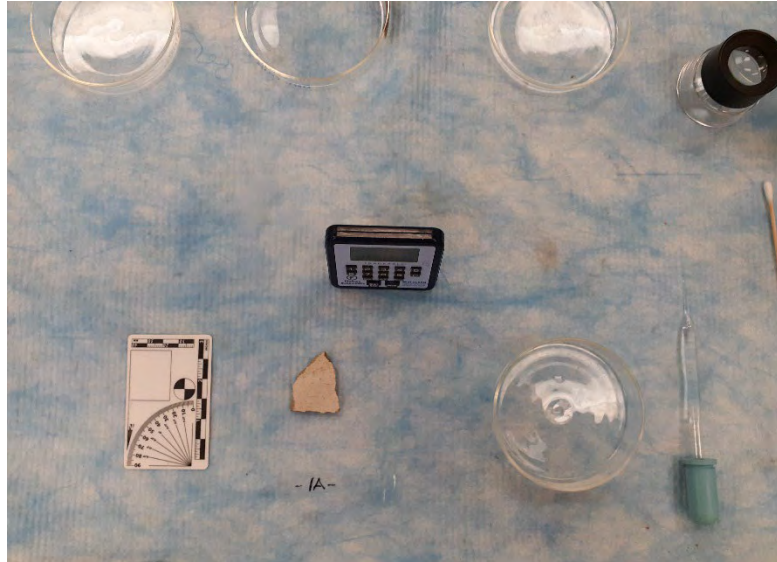
*Table A10.1 – Results of the Microdrop Water Absorption Test*

Samples	# of Drops per sample	Dry-Time on Sample (Secs)	Dry-Time on Glass Plate (Secs) – 30 mins +	Total (Dry time on Sample ÷ Dry time on Glass X 100)
1A	2	90 secs	1800 secs +	5%
1B	2	100 secs	1800 secs +	5.5%
2A	2	618 secs & 935 secs <sup>1</sup>	1800 secs +	34.3% & 51.9%
2B	2	47 secs & 120 secs	1800 secs +	2.6%
3A	1	190 secs	1800 secs +	10%
4	2	679 secs & 1,727 secs	1800 secs +	37.7% & 95.9%
5	2	45 secs & 120 mins <sup>2</sup>	1800 secs +	2.5% & 6.6%

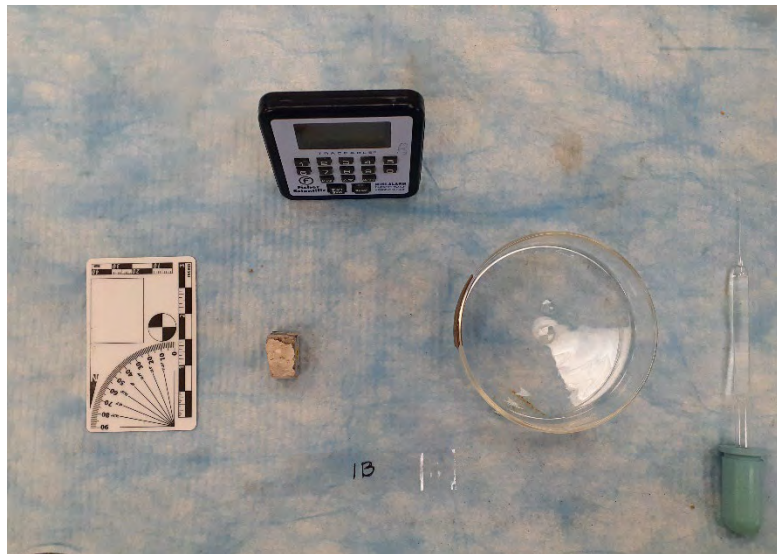
<sup>1</sup> Drop absorbed at 10 min and 18 secs on area without paint coating + Drop absorbed 15 min 35 seg on area with paint coat

<sup>2</sup> 1 Drop in uncoated area absorbed at 45 secs / 1 Drop in painted-coated area absorbed at 2 mins

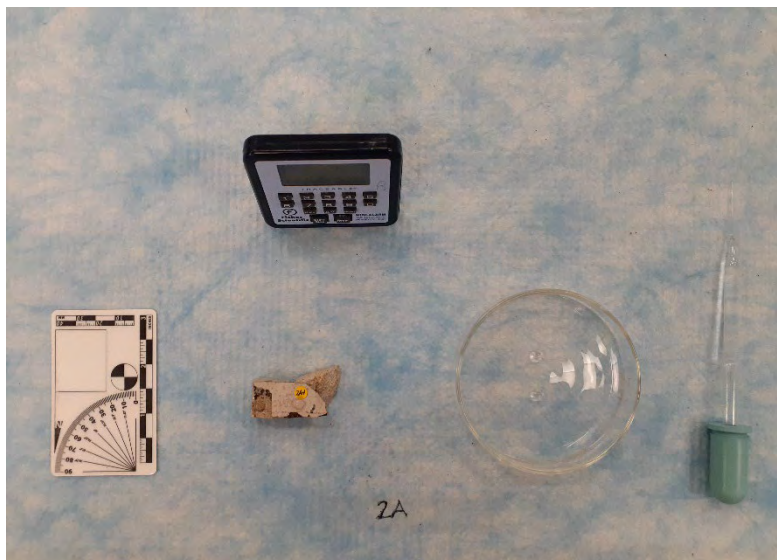
SAMPLE 1A



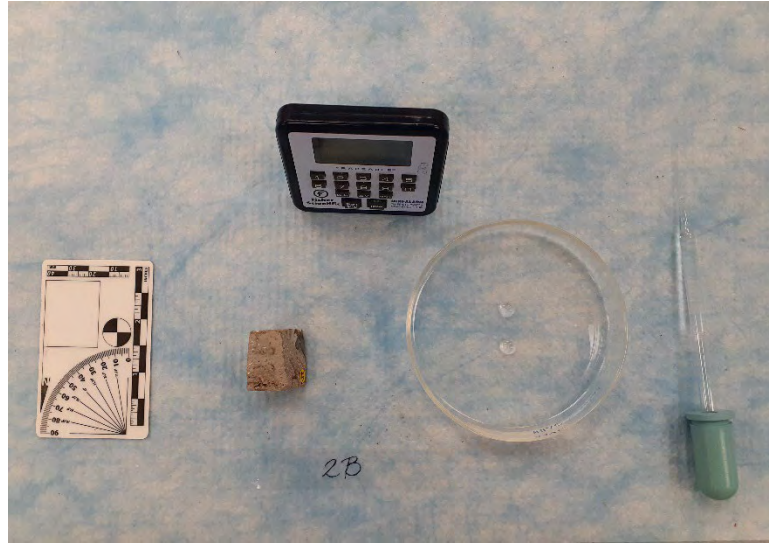
SAMPLE 1B



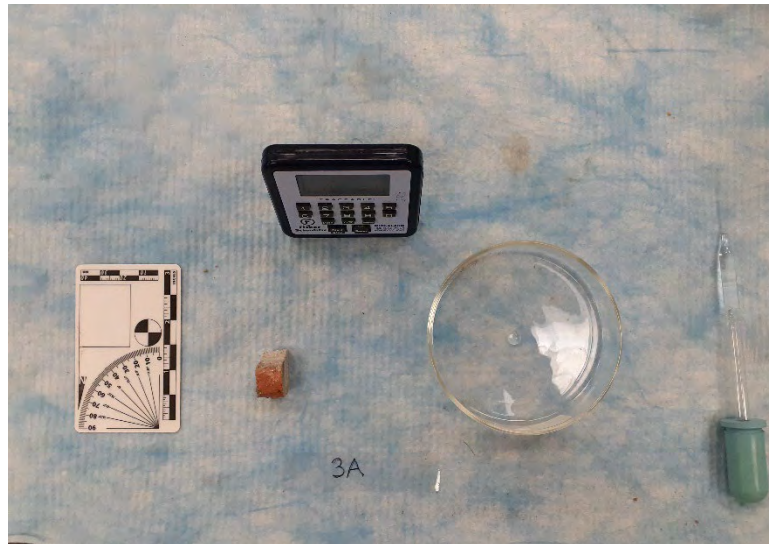
SAMPLE 2A



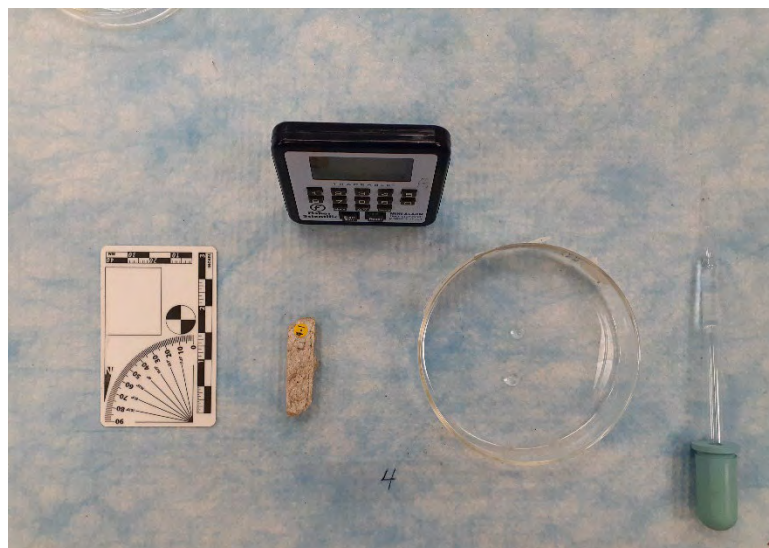
SAMPLE 2B



SAMPLE 3A

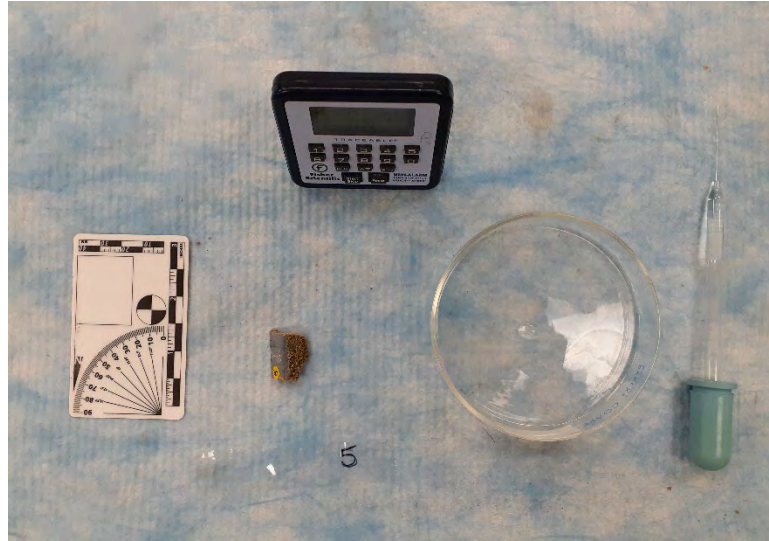


SAMPLE 4





SAMPLE 5



## APPENDIX 9

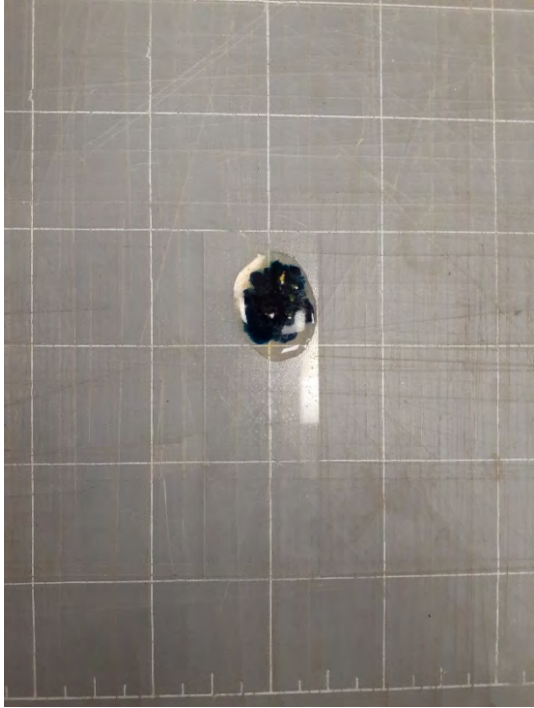
### MICROCHEMICAL SPOT TEST



Remnants of Samples 2A-1 & 2A-3 were ground with a mortar and pestle. Fine ferrous metallic aggregates were selected for the test.



The fillings were dissolve in hydrochloric acid soln. and heated, then redissolved in 2 drops of deionized water.



A drop of potassium ferrocyanide soln. was added and it turned to an intense blue (Prussian Blue -  $C_{18}Fe_7N_{18}$ )



A drop of ammonium thiocyanate soln. was added, and the solution transformed to a blood red color, confirming the presence of iron in the fillings.

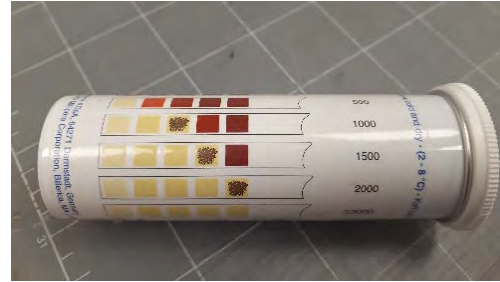
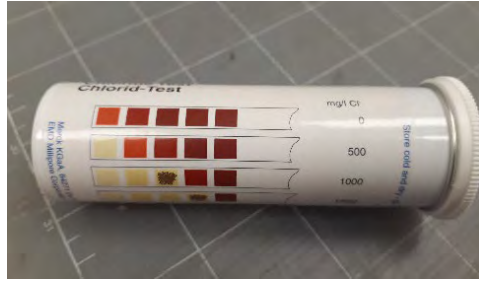
## APPENDIX 12

### SEMI-QUANTITATIVE SALT ANALYSIS

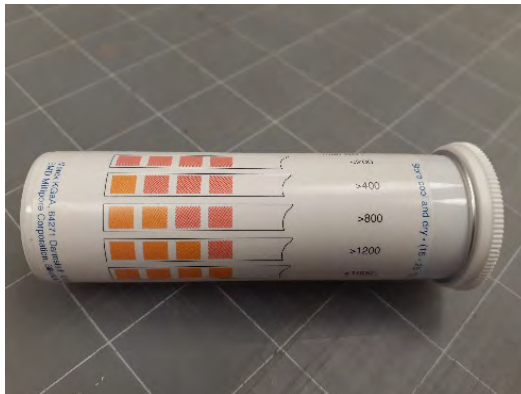
*Table A12.1 – Semi-Quantitative Salt Analysis Results*

Sample	Amount of Powder (g) (Total weight – weight of cup)	Sulfate Content (SO <sub>4</sub> <sup>2-</sup> )	Chloride Content (Cl <sup>-</sup> )	Nitrate Content (NO <sub>3</sub> <sup>-</sup> )
1A	8.37 g	>400 mg/l SO <sub>4</sub> <sup>2-</sup>	500 mg/l Cl <sup>-</sup>	Between 0 and 2.3 of NO <sub>3</sub> -N
1B	4.39 g	>200 mg/l SO <sub>4</sub> <sup>2-</sup>	Between 0 and 500 mg/l Cl <sup>-</sup>	0
2A	10.17 g	>1600 mg/l SO <sub>4</sub> <sup>2-</sup>	Between 0 and 500 mg/l Cl <sup>-</sup>	0
2B	8.93 g	>800 mg/l SO <sub>4</sub> <sup>2-</sup>	Between 0 and 500 mg/l Cl <sup>-</sup>	0
3A	9.96 g	>200 mg/l SO <sub>4</sub> <sup>2-</sup>	0	0
3B	9.5 g	>200 mg/l SO <sub>4</sub> <sup>2-</sup>	500 mg/l Cl <sup>-</sup>	Between 0 and 2.3 of NO <sub>3</sub> -N
4	7.99 g	>1600 mg/l SO <sub>4</sub> <sup>2-</sup>	0	0
5	4.09 g	>200 mg/l SO <sub>4</sub> <sup>2-</sup>	0	0

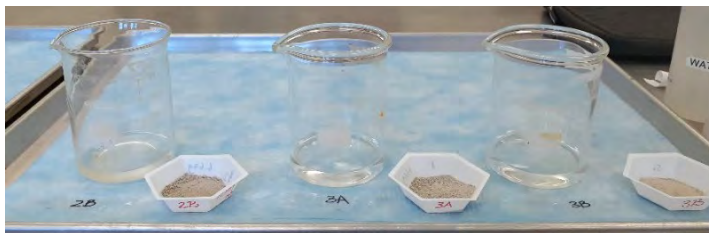
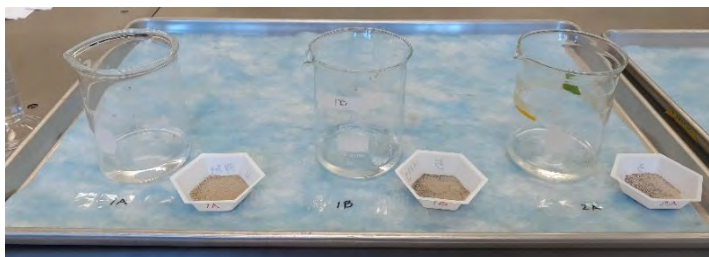
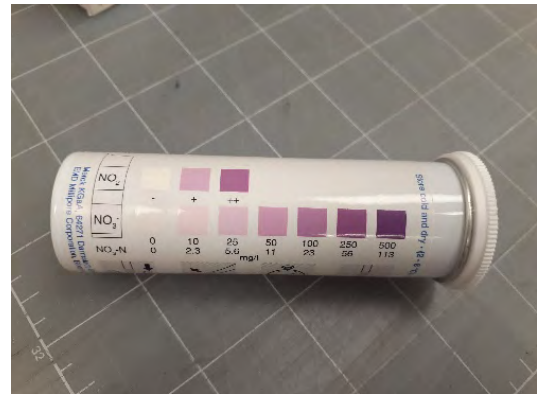
## CHLORIDE TEST



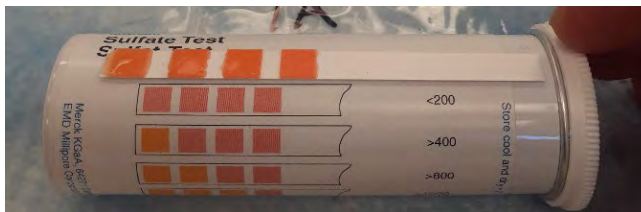
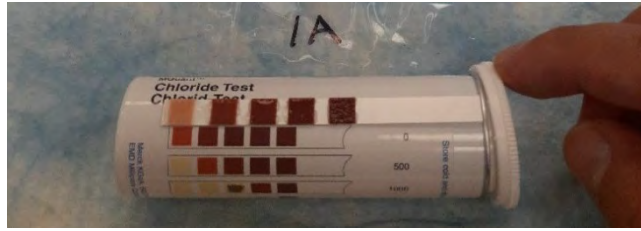
## SULFATE TEST



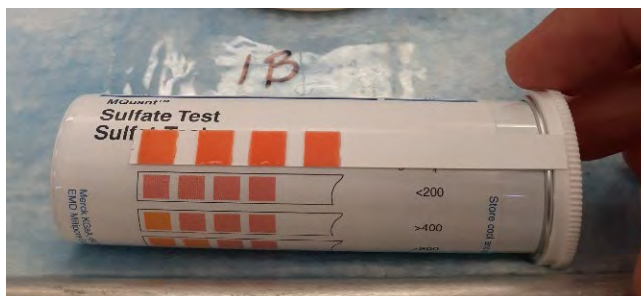
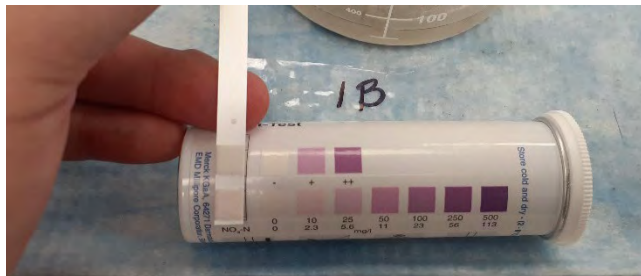
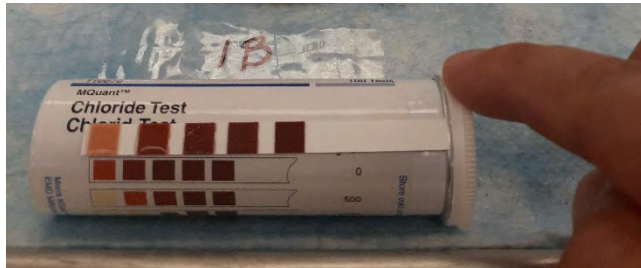
## NITRATE TEST



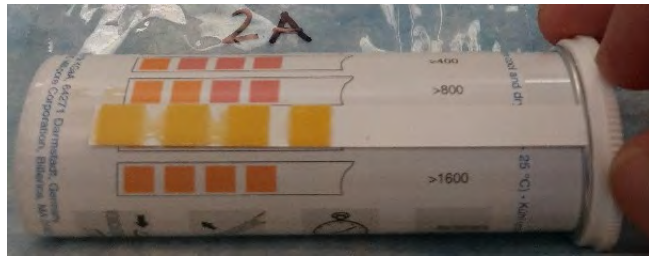
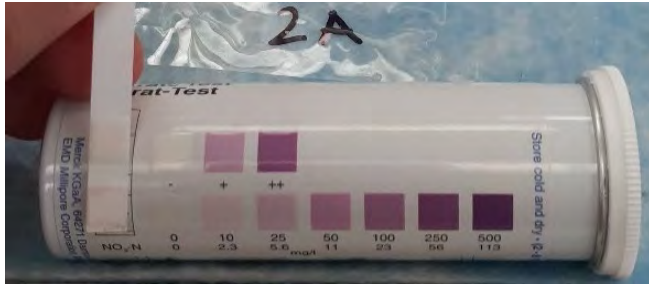
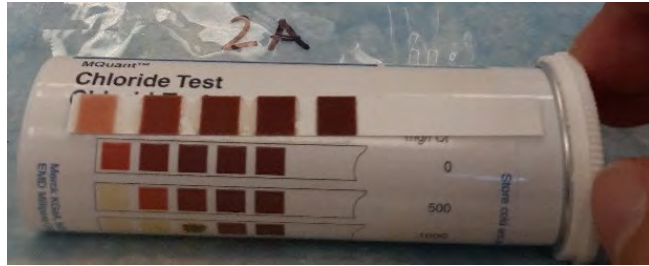
SAMPLE 1A



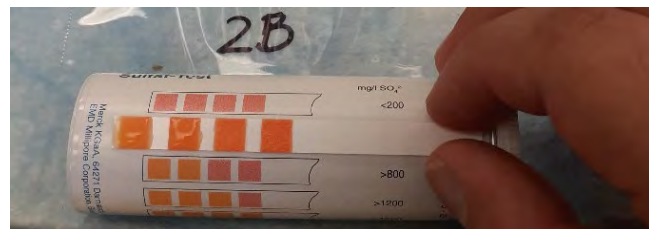
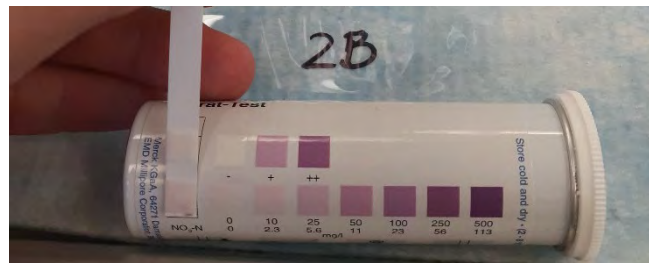
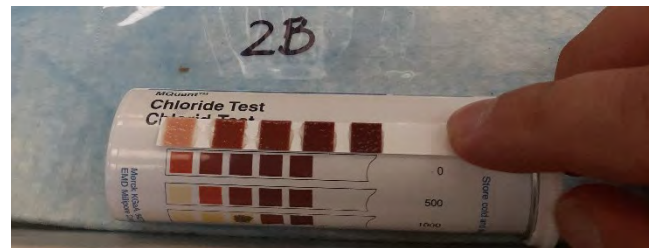
SAMPLE 1B



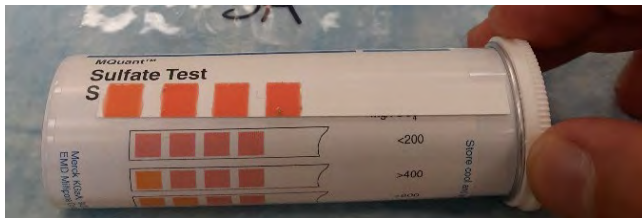
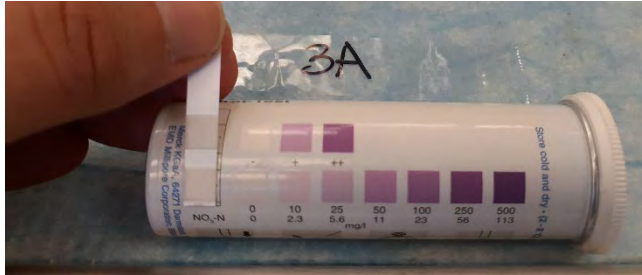
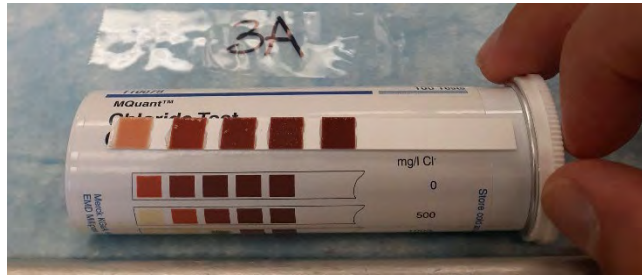
SAMPLE 2A



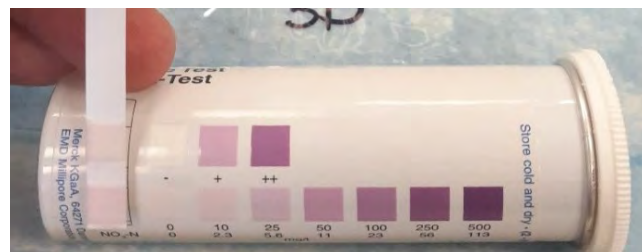
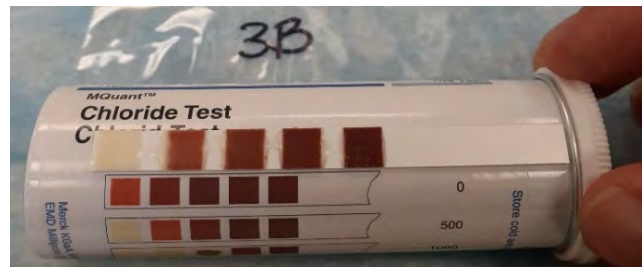
SAMPLE 2B



SAMPLE 3A

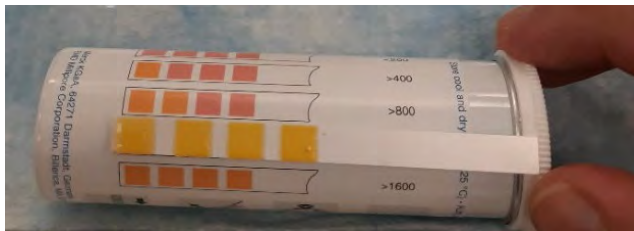
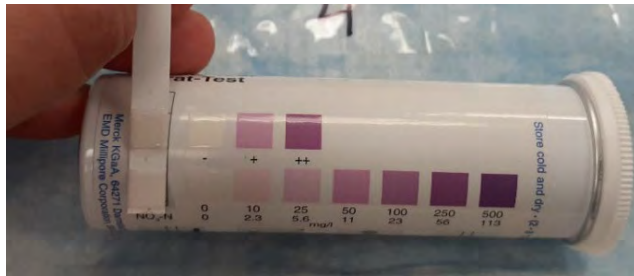
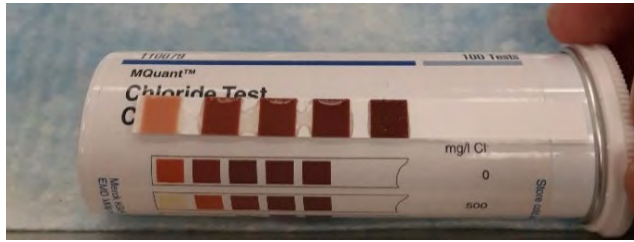


SAMPLE 3B

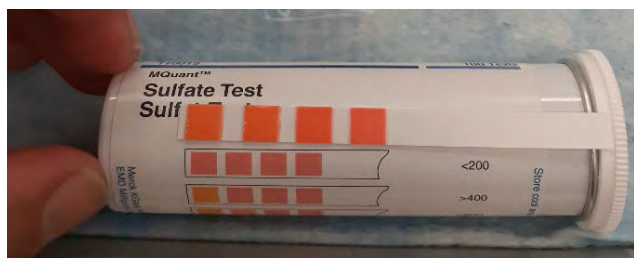
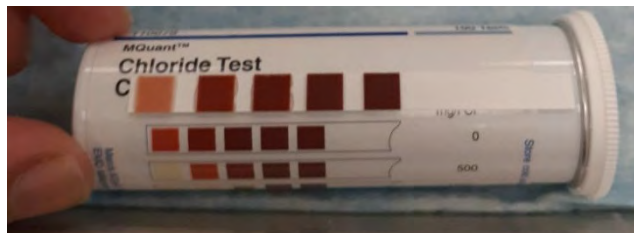




SAMPLE 4



SAMPLE 5



1.10079.0001

## MQuant™ Chloride Test

Cl<sup>-</sup>

### 1. Method

Chloride ions react with silver ions, decolorizing red-brown silver chromate. The chloride concentration is measured **semiquantitatively** by visual comparison of the reaction zones of the test strip with the color rows of a color scale.

### 2. Measuring range and number of determinations

Measuring range / color-scale graduation	Number of determinations
500 - 1000 - 1500 - 2000 - ≥3000 mg/l Cl <sup>-</sup>	100

### 3. Applications

This test is particularly recommended for the determination of the chloride content in conjunction with the COD determination.

The determination can be performed not only in liquid samples, but also on moistened surfaces of e. g. meats and sausages (see section 7).

#### Sample material:

Groundwater and surface water  
Wastewater  
Food

### 4. Influence of foreign substances

The determination is not yet interfered with up to the concentrations of foreign substances given in the table.

Concentrations of foreign substances in mg/l			
Acetate	1000	Mg <sup>2+</sup>	1000
Ag <sup>+</sup>	75	Mn <sup>2+</sup>	1000
Al <sup>3+</sup>	1000	Na <sup>+</sup>	1000
Ascorbate	10	NH <sub>4</sub> <sup>+</sup>	1000
BO <sub>3</sub> <sup>3-</sup>	1000	Ni <sup>2+</sup>	1000
Br <sup>-</sup>	75	NO <sub>2</sub> <sup>-</sup>	1000
Ca <sup>2+</sup>	1000	NO <sub>3</sub> <sup>-</sup>	1000
Cd <sup>2+</sup>	1000	OCN <sup>-</sup>	1000
Ce <sup>3+</sup>	1000	Oxalate	1000
Citrate	1000	Pb <sup>2+</sup>	1000
CN <sup>-</sup>	1000	PO <sub>4</sub> <sup>3-</sup>	1000
CO <sub>3</sub> <sup>2-</sup>	1000	S <sup>2-</sup>	20
Cr <sup>3+</sup>	1000	SCN <sup>-</sup>	100
CrO <sub>4</sub> <sup>2-</sup>	1000	Sn <sup>4+</sup>	1000
Cu <sup>2+</sup>	1000	SO <sub>4</sub> <sup>2-</sup>	1000
Fe <sup>2+</sup>	1000	SO <sub>3</sub> <sup>2-</sup>	1000
Fe <sup>3+</sup>	1000	S <sub>2</sub> O <sub>3</sub> <sup>2-</sup>	75
Hg <sup>2+</sup>	75	Tartrate	1000
I <sup>-</sup>	100	Zn <sup>2+</sup>	1000
K <sup>+</sup>	1000		

### 5. Reagents and auxiliaries

The test strips are stable up to the date stated on the pack when stored closed at +2 to +8 °C.

#### Package contents:

Tube containing 100 test strips

#### Other reagents:

MColorpHast™ Universal indicator strips pH 0 - 14, Cat. No. 109535  
Sodium hydroxide solution 1 mol/l Titripur®, Cat. No. 109137  
Nitric acid Titrisol® for 1 mol/l, Cat. No. 109966  
Chloride standard solution Certipur®, 1000 mg/l Cl<sup>-</sup>, Cat. No. 119897

### 6. Preparation

- Samples containing more than 3000 mg/l Cl<sup>-</sup> must be diluted with distilled water.
- The pH must be within the range 5 - 8. Adjust, if necessary, with sodium hydroxide solution or nitric acid.
- Moisten solid samples with distilled water.

### 7. Procedure

Immerse **all reaction zones** of the test strip in the pre-treated sample (15 - 25 °C) for **1 sec** or, respectively, bring into contact with the moistened solid sample.

Shake off excess liquid from the strip and **after 1 min** determine with which color row on the label the colors of the reaction zones coincide most exactly.

Read off the corresponding result in mg/l Cl<sup>-</sup>.

#### Notes on the measurement:

- The color of the reaction zones may continue to change after the specified reaction time has elapsed. This must not be considered in the measurement.
- If the appearance of the reaction zones corresponds to that of the color row for ≥3000 mg/l Cl<sup>-</sup>, the chloride concentration may actually be considerably higher. In this case, the measurement should therefore be repeated using **fresh**, diluted samples until a value of less than 3000 mg/l Cl<sup>-</sup> is obtained.

Concerning the result of the analysis, the dilution (see also section 6) must be taken into account:

Result of analysis = measurement value x dilution factor

- The measurement results obtained on moistened surfaces are only guideline values.

### 8. Method control

To check test strips and handling:

Analyze the chloride standard solution as described in section 7.

Additional notes see under [www.qa-test-kits.com](http://www.qa-test-kits.com).

### 9. Note

Reclose the tube containing the test strips immediately after use.



1.10079.0001

**MQuant™  
Test Cloruros**

**Cl<sup>-</sup>**

**1. Método**

Los iones cloruro reaccionan con los iones plata y decoloran entonces el cromato de plata de color pardo rojizo. La concentración de cloruros se determina **semicuantitativamente** por comparación visual de las zonas de reacción de la tira de ensayo con las series cromáticas de una escala colorimétrica.

**2. Intervalo de medida y número de determinaciones**

Intervalo de medida / graduación de la escala colorimétrica	Número de determinaciones
500 - 1000 - 1500 - 2000 - >3000 mg/l de Cl <sup>-</sup>	100

**3. Campo de aplicaciones**

El test es recomendado especialmente para el control del contenido de cloruros en relación con la determinación de la demanda química de oxígeno (DQO).

La determinación se puede realizar no solamente en muestras líquidas sino también en superficies humedecidas, p. ej. de productos cárnicos y embutidos (ver apartado 7).

**Material de las muestras:**

Aguas subterráneas y superficiales  
Aguas residuales  
Alimentos

**4. Influencia de sustancias extrañas**

Hasta las concentraciones de sustancias extrañas indicadas en la tabla la determinación todavía no es interferida.

Concentración de sustancias extrañas en mg/l			
Acelato	1000	Mg <sup>2+</sup>	1000
Ag <sup>+</sup>	75	Mn <sup>2+</sup>	1000
Al <sup>3+</sup>	1000	Na <sup>+</sup>	1000
<b>Ascorbato</b>	<b>10</b>	NH <sub>4</sub> <sup>+</sup>	1000
BO <sub>3</sub> <sup>3-</sup>	1000	Ni <sup>2+</sup>	1000
Br <sup>-</sup>	75	NO <sub>2</sub> <sup>-</sup>	1000
Ca <sup>2+</sup>	1000	NO <sub>3</sub> <sup>-</sup>	1000
Cd <sup>2+</sup>	1000	OCN <sup>-</sup>	1000
Ce <sup>3+</sup>	1000	Oxalato	1000
Citrato	1000	Pb <sup>2+</sup>	1000
CN <sup>-</sup>	1000	PO <sub>4</sub> <sup>3-</sup>	1000
CO <sub>3</sub> <sup>2-</sup>	1000	S <sup>2-</sup>	20
Cr <sup>3+</sup>	1000	SCN <sup>-</sup>	100
CrO <sub>4</sub> <sup>2-</sup>	1000	Sn <sup>2+</sup>	1000
Cu <sup>2+</sup>	1000	SO <sub>3</sub> <sup>2-</sup>	1000
Fe <sup>2+</sup>	1000	SO <sub>4</sub> <sup>2-</sup>	1000
Fe <sup>3+</sup>	1000	S <sub>2</sub> O <sub>3</sub> <sup>2-</sup>	75
Hg <sup>2+</sup>	75	Tartrato	1000
I <sup>-</sup>	100	Zn <sup>2+</sup>	1000
K <sup>+</sup>	1000		
		EDTA	1000

**5. Reactivos y auxiliares**

Las tiras de ensayo son utilizables hasta la fecha indicada en el envase si se conservan cerradas entre +2 y +8 °C.

**Contenido del envase:**

Caja con 100 tiras de ensayo

**Otros reactivos:**

MColorpHast™ Tiras indicadoras universales pH 0 - 14, art. 109535  
Sodio hidróxido en solución 1 mol/l Titripur®, art. 109137  
Ácido nítrico Titrisol® para 1 mol/l, art. 109966  
Cloruros - solución patrón Certipur®, 1000 mg/l de Cl<sup>-</sup>, art. 119897

**6. Preparación**

- Las muestras con más de 3000 mg/l de Cl<sup>-</sup> deben diluirse con agua destilada.
- El valor del pH debe encontrarse en el intervalo 5 - 8.  
Si es necesario, ajustar con solución de hidróxido sódico o con ácido nítrico.
- Humedecer las muestras sólidas con agua destilada.

**7. Técnica**

Introducir **todas las zonas de reacción** de la tira de ensayo **durante 1 segundo** en la muestra preparada (15 - 25 °C) o ponerlas en contacto con la muestra sólida humedecida.

Eliminar el exceso de líquido de la tira sacudiéndola y, **después de 1 minuto**, clasificar los colores de las zonas de reacción de la mejor manera posible de acuerdo con una serie cromática de la escala colorimétrica.

Leer el correspondiente valor de medición en mg/l de Cl<sup>-</sup>.

**Notas sobre la medición:**

- Después de transcurrido el tiempo de reacción indicado, las zonas de reacción pueden continuar cambiando de color. Esto no debe ser tenido en cuenta en la medición.
- Si el aspecto de las zonas de reacción corresponde al de la serie cromática para ≥3000 mg/l de Cl<sup>-</sup>, puede existir una concentración de cloruros considerablemente superior. Por lo tanto, en este caso debe repetirse la medición con **nuevas** muestras diluidas, hasta que se obtenga un valor inferior a 3000 mg/l de Cl<sup>-</sup>.
- En el resultado del análisis debe considerarse correspondientemente la dilución (ver también apartado 6):

Resultado del análisis = valor de medición x factor de dilución

- Los resultados de medición obtenidos en superficies humedecidas son solamente valores orientativos.

**8. Control del procedimiento**

Comprobación de las tiras de ensayo y de la manipulación:  
Analizar la solución patrón de cloruros como se describe en el apartado 7.

Notas adicionales, ver bajo [www.qa-test-kits.com](http://www.qa-test-kits.com).

**9. Nota**

Cerrar de nuevo inmediatamente la caja tras la toma de la tira de ensayo.

Merck KGaA, 64271 Darmstadt, Germany.  
Tel. +49(0)615172-2440  
[www.analytical-test-kits.com](http://www.analytical-test-kits.com)

EMD Millipore Corporation, 290 Concord Road,  
Billerica, MA 01821, USA. Tel. +1.978.715.4221



1.10020.0001  
1.10020.0002MQuant™  
Nitrate TestNO<sub>3</sub><sup>-</sup>

## 1. Method

Nitrate ions are reduced to nitrite ions by a reducing agent. In the presence of an acidic buffer, these nitrite ions react with an aromatic amine to form a diazonium salt, which in turn reacts with N-(1-naphthyl)-ethylene-diamine to form a red-violet azo dye. The nitrate concentration is measured **semiquantitatively** by visual comparison of the reaction zone of the test strip with the fields of a color scale.

Each strip also features a second reaction zone (**alert zone**), the color of which changes in the presence of nitrite ions.

## 2. Measuring range and number of determinations

Measuring range / color-scale graduation <sup>1)</sup>	Number of determinations
10 - 25 - 50 - 100 - 250 - 500 mg/l NO <sub>3</sub> <sup>-</sup>	25 (Cat. No. 1.10020.0002) or
2.3 - 5.6 - 11 - 23 - 56 - 113 mg/l NO <sub>3</sub> -N	100 (Cat. No. 1.10020.0001)

<sup>1)</sup> for conversion factors see section 8

## 3. Applications

The determination can be performed not only in liquid samples, but also on moist surfaces of e.g. freshly cut fruit and vegetables (see section 7).

## Sample material:

Groundwater, well water, and drinking water  
Spring water and mineral water  
Industrial water, wastewater, percolating water  
Aquarium water  
Pressed plant and fruit juices  
Food and animal fodder after appropriate sample pretreatment  
Soils and fertilizers after appropriate sample pretreatment  
This test is **only conditionally suited** for seawater (false-low readings).

## 4. Influence of foreign substances

This was checked in solutions with 50 and 0 mg/l NO<sub>3</sub><sup>-</sup>. The determination is not yet interfered with up to the concentrations of foreign substances given in the table.

Concentrations of foreign substances in mg/l					
Ag <sup>+</sup>	50	Fe <sup>3+</sup>	250	NO <sub>2</sub> <sup>-</sup>	0.5 <sup>1)</sup>
Al <sup>3+</sup>	1000	[Fe(CN) <sub>6</sub> ] <sup>4-</sup>	100	Pb <sup>2+</sup>	1000
Ba <sup>2+</sup>	1000	[Fe(CN) <sub>6</sub> ] <sup>3-</sup>	100	PO <sub>4</sub> <sup>3-</sup>	1000
Ca <sup>2+</sup>	1000	Hg <sup>2+</sup>	50	S <sup>2-</sup>	25
Cl <sup>-</sup>	1000	Hg <sup>2+</sup>	100	SCN <sup>-</sup>	100
CN <sup>-</sup>	1000	K <sup>+</sup>	1000	SO <sub>3</sub> <sup>2-</sup>	500
Co <sup>2+</sup>	1000	Mg <sup>2+</sup>	1000	SO <sub>4</sub> <sup>2-</sup>	1000
CrO <sub>4</sub> <sup>2-</sup>	20	Mn <sup>2+</sup>	1000	S <sub>2</sub> O <sub>3</sub> <sup>2-</sup>	250
Cu <sup>2+</sup>	1000	MnO <sub>4</sub> <sup>-</sup>	10	Zn <sup>2+</sup>	1000
Fe <sup>2+</sup>	500	Ni <sup>2+</sup>	1000		

<sup>1)</sup> In case of higher concentrations, eliminate nitrite ions acc. to section 7.

## 5. Reagents and auxiliaries

The test strips are stable up to the date stated on the pack when stored closed at +2 to +8 °C.

## Package contents:

Tube containing 25 test strips (Cat. No. 1.10020.0002) or  
containing 100 test strips (Cat. No. 1.10020.0001)

## Other reagents:

MColorpHast™ Universal indicator strips pH 0 - 14, Cat. No. 109535  
Sodium acetate anhydrous for analysis EMSURE®, Cat. No. 106268  
L(+)-Tartaric acid for analysis EMSURE®, Cat. No. 100804  
Amidosulfuric acid for analysis EMSURE®, Cat. No. 100103  
Nitrate standard solution Certipur®, 1000 mg/l NO<sub>3</sub><sup>-</sup>, Cat. No. 119811

## 6. Preparation

- Extract solid sample materials by an appropriate method.
- Samples containing more than 500 mg/l NO<sub>3</sub><sup>-</sup> must be diluted with distilled water.
- The pH must be within the range 1 - 12.  
If the pH is lower than 1, buffer the sample with sodium acetate; if it is greater than 12, adjust to approx. 3 - 5 with tartaric acid.

## 7. Procedure

Immerse **both reaction zones** of the test strip in the pre-treated sample (15 - 25 °C) for 1 sec.

Shake off excess liquid from the strip and **after 1 min** determine with which color field on the label the color of the NO<sub>3</sub><sup>-</sup> reaction zone coincides most exactly. **If the NO<sub>3</sub><sup>-</sup> alert zone changes color see "Notes on the measurement".**

Read off the corresponding result in mg/l NO<sub>3</sub><sup>-</sup> or NO<sub>3</sub>-N.

## Determination on vegetable surfaces:

Cut plant material (e.g. fruit, vegetables, potatoes) with a knife, lightly press the reaction zone of the test strip on the moist surface for 1 - 10 sec, and **after 1 min** compare with the color scale.

## Notes on the measurement:

- The color of the reaction zone may continue to change after the specified reaction time has elapsed. This must not be considered in the measurement.
- If necessary (discolouration of the alert zone), eliminate interfering nitrite ions:  
To 5 ml of sample (pH < 10) add 5 drops of a 10 % aqueous amidosulfuric acid solution and shake several times.  
Subsequently repeat the nitrate measurement.
- If the color of the reaction zone is equal to or more intense than the darkest color on the scale, repeat the measurement using **fresh**, diluted samples until a value of less than 500 mg/l NO<sub>3</sub><sup>-</sup> is obtained.  
Concerning the result of the analysis, the dilution (see also section 6) must be taken into account:

Result of analysis = measurement value x dilution factor

- It is recommended to treat the measurement results obtained on moist surfaces only as guideline values.

## 8. Conversions

Units required =	units given	x	conversion factor
mg/l NO <sub>3</sub> -N	mg/l NO <sub>3</sub> <sup>-</sup>		0.226
mg/l NO <sub>3</sub> <sup>-</sup>	mg/l NO <sub>3</sub> -N		4.43

## 9. Method control

To check test strips and handling:  
Dilute the nitrate standard solution with distilled water to 250 mg/l NO<sub>3</sub><sup>-</sup> and analyze as described in section 7. Additional notes see under [www.qa-test-kits.com](http://www.qa-test-kits.com).

## 10. Note

Reclose the tube containing the test strips immediately after use.

Merck KGaA, 64271 Darmstadt, Germany.  
Tel. +49(0)6181 72-2440  
[www.analytical-test-kits.com](http://www.analytical-test-kits.com)

EMD Millipore Corporation, 290 Concord Road,  
Billerica, MA 01821 USA Tel. +1-978-715-4321



1.10020.0001  
1.10020.0002

MQuant™  
Test Nitratos



1. Método

Los iones nitrato se reducen a iones nitrito por la acción de un reductor. Los iones nitrito, en presencia de un tampón ácido, reaccionan con una amina aromática dando una sal de diazonio. Ésta reacciona con N-(1-naftil)-etilendiamina dando un azocolorante violeta rojizo. La concentración de nitratos se determina **semicuantitativamente** por comparación visual de la zona de reacción de la tira de ensayo con las zonas de una escala colorimétrica.

Cada tira tiene además una segunda zona de reacción (**zona de alarma**) que cambia de color en caso de presencia de iones nitrito.

2. Intervalo de medida y número de determinaciones

Intervalo de medida / graduación de la escala colorimétrica <sup>1)</sup>	Número de determinaciones
10 - 25 - 50 - 100 - 250 - 500 mg/l de NO <sub>3</sub>	25 (art. 1.10020.0002)
2,3 - 5,6 - 11 - 23 - 56 - 113 mg/l de NO <sub>2</sub> -N <sup>2)</sup>	100 (art. 1.10020.0001)

<sup>1)</sup> factores de conversión, ver apartado 8  
<sup>2)</sup> N de nitrato

3. Campo de aplicaciones

La determinación se puede realizar no solamente en muestras líquidas sino también en superficies húmedas, p. ej. de fruta y verdura recién cortadas (ver apartado 7).

Material de las muestras:

- Aguas subterráneas, de pozo y potables
- Aguas de manantial y minerales
- Aguas industriales, aguas residuales, aguas de infiltración
- Aguas de acuario
- Zumos de plantas y frutas comprimidos
- Alimentos y piensos tras preparación apropiada de la muestra
- Suelos y fertilizantes tras preparación apropiada de la muestra
- Para agua de mar el test **sólo es adecuado hasta cierto punto** (valores falsamente bajos).

4. Influencia de sustancias extrañas

Ésta se comprobó en soluciones con 50 y con 0 mg/l de NO<sub>3</sub><sup>-</sup>. Hasta las concentraciones de sustancias extrañas indicadas en la tabla la determinación todavía no es interferida.

Concentración de sustancias extrañas en mg/l				
Ag <sup>+</sup>	50	Fe <sup>3+</sup>	250	NO <sub>2</sub> <sup>-</sup> 0,5 <sup>1)</sup>
Al <sup>3+</sup>	1000	[Fe(CN) <sub>6</sub> ] <sup>4-</sup>	100	Pb <sup>2+</sup> 1000
Ba <sup>2+</sup>	1000	[Fe(CN) <sub>6</sub> ] <sup>3-</sup>	100	PO <sub>4</sub> <sup>3-</sup> 1000
Ca <sup>2+</sup>	1000	Hg <sup>2+</sup>	50	S <sup>2-</sup> 25
Cl <sup>-</sup>	1000	Hg <sup>2+</sup>	100	SCN <sup>-</sup> 100
CN <sup>-</sup>	1000	K <sup>+</sup>	1000	SO <sub>4</sub> <sup>2-</sup> 500
Co <sup>2+</sup>	1000	Mg <sup>2+</sup>	1000	SO <sub>3</sub> <sup>2-</sup> 1000
CrO <sub>4</sub> <sup>2-</sup>	20	Mn <sup>2+</sup>	1000	S <sub>2</sub> O <sub>3</sub> <sup>2-</sup> 250
Cu <sup>2+</sup>	1000	MnO <sub>4</sub> <sup>-</sup>	10	Zn <sup>2+</sup> 1000
Fe <sup>2+</sup>	500	Ni <sup>2+</sup>	1000	

<sup>1)</sup> En caso de concentraciones más elevadas eliminar los iones nitrito según el apartado 7.

5. Reactivos y auxiliares

Las tiras de ensayo son utilizables hasta la fecha indicada en el envase si se conservan cerradas entre +2 y +8 °C.

Contenido del envase:

Caja con 25 tiras de ensayo (art. 1.10020.0002)  
o  
con 100 tiras de ensayo (art. 1.10020.0001)

Otros reactivos:

- MColorpHast™ Tiras indicadoras universales pH 0 - 14, art. 109535
- Sodio acetato anhidro para análisis EMSURE®, art. 106268
- Ácido L(+)-tartárico para análisis EMSURE®, art. 100804
- Ácido amidosulfúrico para análisis EMSURE®, art. 100103

6. Preparación

- Extraer las muestras sólidas según un procedimiento adecuado.
- Las muestras con más de 500 mg/l de NO<sub>3</sub><sup>-</sup> deben diluirse con agua destilada.
- El valor del pH debe encontrarse en el intervalo 1 - 12.  
Si el pH es menor que 1, amortiguar la muestra con acetato sódico; si es mayor que 12, ajustar a un valor de aprox. 3 - 5 con ácido tartárico.

7. Técnica

Introducir la tira de ensayo con ambas zonas de reacción durante 1 segundo en la muestra preparada (15 - 25 °C).  
Eliminar el exceso de líquido de la tira sacudiéndola y, después de 1 minuto, clasificar el color de la zona de reacción de NO<sub>3</sub><sup>-</sup> de la mejor manera posible de acuerdo con una zona de color de la etiqueta.  
**En caso de cambio de color de la zona de alarma de NO<sub>2</sub><sup>-</sup>, ver "Notas sobre la medición".**  
Leer el correspondiente valor de medición en mg/l de NO<sub>3</sub><sup>-</sup> o de NO<sub>2</sub>-N.

Determinación en superficies de plantas:

Entallar o cortar las plantas (p. ej. fruta, verdura, patatas) con un cuchillo, apretar ligeramente la zona de reacción de la tira durante 1 - 10 segundos sobre la zona húmeda del corte y después de 1 minuto comparar con la escala colorimétrica.

Notas sobre la medición:

- Después de transcurrido el tiempo de reacción indicado, la zona de reacción puede continuar cambiando de color. Esto no debe ser tenido en cuenta en la medición.
- Si es necesario (cambio de color de la zona de alarma), eliminar los iones nitrito interferentes:  
Añadir 5 gotas de una solución acuosa al 10 % de ácido amidosulfúrico a 5 ml de la muestra (pH < 10) y agitar varias veces.  
Seguidamente repetir la determinación de nitratos.
- Si el color de la zona de reacción corresponde a la tonalidad más oscura de la escala colorimétrica o es más intenso, debe repetirse la medición con nuevas muestras diluidas, hasta que se obtenga un valor inferior a 500 mg/l de NO<sub>3</sub><sup>-</sup>.

En el resultado del análisis debe considerarse correspondientemente la dilución (ver también apartado 6):

Resultado del análisis = valor de medición x factor de dilución

- Se recomienda considerar solamente como valores orientativos los resultados de medición obtenidos en superficies húmedas.

8. Conversiones

Contenido buscado	= contenido dado x	factor de conversión
mg/l de NO <sub>3</sub> -N	mg/l de NO <sub>3</sub> <sup>-</sup>	0,226
mg/l de NO <sub>3</sub> <sup>-</sup>	mg/l de NO <sub>3</sub> -N	4,43

9. Control del procedimiento

Comprobación de las tiras de ensayo y de la manipulación:

Diluir la solución patrón de nitratos con agua destilada a 250 mg/l de NO<sub>3</sub><sup>-</sup> y analizar como se describe en el apartado 7.

Notas adicionales, ver bajo [www.qa-test-kits.com](http://www.qa-test-kits.com).

10. Nota

Cerrar de nuevo inmediatamente la caja tras la toma de la tira de ensayo.

Merck KGaA, 64271 Darmstadt, Germany.  
Tel. +49(0)6151 72-2440  
[www.analytical-test-kits.com](http://www.analytical-test-kits.com)

EMN Millipore Corporation 290 Concord Road



1.10019.0001

## MQuant™ Sulfate Test

SO<sub>4</sub><sup>2-</sup>

### 1. Method

Sulfate ions react with a red thorin-barium complex, releasing yellow thorin in the process. The sulfate concentration is measured **semiquantitatively** by visual comparison of the reaction zones of the test strip with the color rows of a color scale.

### 2. Measuring range and number of determinations

Measuring range / color-scale graduation	Number of determinations
<200 - >400 - >800 - >1200 - >1600 mg/l SO <sub>4</sub> <sup>2-</sup>	100

### 3. Applications

#### Sample material:

Groundwater and surface water  
Drinking water  
Wastewater  
Industrial water

### 4. Influence of foreign substances

This was checked in solutions containing 800 and 0 mg/l SO<sub>4</sub><sup>2-</sup>. The determination is not yet interfered with up to the concentrations of foreign substances given in the table.

Concentrations of foreign substances in mg/l					
Al <sup>3+</sup>	100	CrO <sub>4</sub> <sup>2-</sup>	400	Fe(CN) <sub>6</sub> <sup>3-</sup>	400
CN <sup>-</sup>	50	Cu <sup>2+</sup>	10	S <sup>2-</sup>	25
Cr <sup>3+</sup>	100	[Fe(CN) <sub>6</sub> ] <sup>4-</sup>	400	SO <sub>3</sub> <sup>2-</sup>	25

### 5. Reagents and auxiliaries

The test strips are stable up to the date stated on the pack when stored closed at +15 to +25 °C.

#### Package contents:

Tube containing 100 test strips

#### Other reagents:

MColorpHast™ Universal indicator strips pH 0 - 14, Cat. No. 109535  
Sodium acetate anhydrous GR for analysis, Cat. No. 106268  
L(+)-Tartaric acid GR for analysis, Cat. No. 100804  
Sulfate standard solution Certipur®, 1000 mg/l SO<sub>4</sub><sup>2-</sup>, Cat. No. 119813

### 6. Preparation

- Samples containing more than 1600 mg/l SO<sub>4</sub><sup>2-</sup> must be diluted with distilled water.
- **The pH must be within the range 4 - 8.**  
If necessary, buffer the sample with sodium acetate or, respectively, adjust the pH with tartaric acid.

### 7. Procedure

Immerse **all reaction zones** of the test strip in the pre-treated sample (15 - 25 °C) for **1 sec (not in running water!)**.

Shake off excess liquid from the strip and **after 2 min** determine with which color row on the label the colors of the reaction zones coincide most exactly.

Read off the corresponding result in mg/l SO<sub>4</sub><sup>2-</sup>.

### Notes on the measurement:

- The colors of the reaction zones may continue to change after the specified reaction time has elapsed. This must not be considered in the measurement.
- **If the measurement sample has a sulfate content lying between two adjacent values indicated on the color scale, one of the reaction zones shows a yellow area in the middle.**
- Concerning the result of the analysis, the dilution (see also section 6) must be taken into account:

Result of analysis = measurement value x dilution factor

### 8. Method control

To check test strips and handling:  
Analyze the sulfate standard solution as described in section 7.  
Additional notes see under [www.qa-test-kits.com](http://www.qa-test-kits.com).

### 9. Note

Reclose the tube containing the test strips immediately after use.



1.10019.0001

**MQuant™  
Test Sulfatos**



**1. Método**

Los iones sulfato reaccionan con un complejo torina-bario de color rojo y liberan entonces torina amarilla. La concentración de sulfatos se determina **semi-cuantitativamente** por comparación visual de las zonas de reacción de la tira de ensayo con las series cromáticas de una escala colorimétrica.

**2. Intervalo de medida y número de determinaciones**

Intervalo de medida / graduación de la escala colorimétrica	Número de determinaciones
<200 - >400 - >800 - >1200 - >1600 mg/l de SO <sub>4</sub> <sup>2-</sup>	100

**3. Campo de aplicaciones**

**Material de las muestras:**  
Aguas subterráneas y superficiales  
Agua potable  
Aguas residuales  
Aguas industriales

**4. Influencia de sustancias extrañas**

Ésta se comprobó en soluciones con 800 y con 0 mg/l de SO<sub>4</sub><sup>2-</sup>. Hasta las concentraciones de sustancias extrañas indicadas en la tabla la determinación todavía no es interferida.

Concentración de sustancias extrañas en mg/l					
Al <sup>3+</sup>	100	CrO <sub>4</sub> <sup>2-</sup>	400	Fe(CN) <sub>6</sub> <sup>3-</sup>	400
CN <sup>-</sup>	50	Cu <sup>2+</sup>	10	S <sup>2-</sup>	25
Cr <sup>3+</sup>	100	[Fe(CN) <sub>6</sub> ] <sup>4-</sup>	400	SO <sub>3</sub> <sup>2-</sup>	25

**5. Reactivos y auxiliares**

Las tiras de ensayo son utilizables hasta la fecha indicada en el envase si se conservan cerradas entre +15 y +25 °C.

**Contenido del envase:**  
Caja con 100 tiras de ensayo

**Otros reactivos:**  
MColorpHast™ Tiras indicadoras universales pH 0 - 14, art. 109535  
Sodio acetato anhidro para análisis, art. 106268  
Ácido L(+)-tartárico para análisis, art. 100804  
Sulfatos - solución patrón Certipur®, 1000 mg/l de SO<sub>4</sub><sup>2-</sup>, art. 119813

**6. Preparación**

- Las muestras con más de 1600 mg/l de SO<sub>4</sub><sup>2-</sup> deben diluirse con agua destilada.
- **El valor del pH debe encontrarse en el intervalo 4 - 8.**  
Si es necesario, amortiguar la muestra con acetato sódico o ajustar el pH con ácido tartárico.

**7. Técnica**

Introducir **todas las zonas de reacción** de la tira de ensayo **durante 1 segundo** en la muestra preparada (15 - 25 °C) (**¡no en agua corriente del grifo!**).  
Eliminar el exceso de líquido de la tira sacudiéndola y, **después de 2 minutos**, clasificar los colores de las zonas de reacción de la mejor manera posible de acuerdo con una serie cromática de la escala colorimétrica.  
Leer el correspondiente valor de medición en mg/l de SO<sub>4</sub><sup>2-</sup>.

**Notas sobre la medición:**

- Después de transcurrido el tiempo de reacción indicado, las zonas de reacción pueden continuar cambiando de color. Esto no debe ser tenido en cuenta en la medición.
- **Si la muestra de medición tiene un contenido de sulfato que se encuentra entre dos valores vecinos indicados en la escala colorimétrica, entonces una de las zonas de reacción muestra en el centro un sector amarillo.**
- En el resultado del análisis debe considerarse correspondientemente la dilución (ver también apartado 6):

Resultado del análisis = valor de medición x factor de dilución

**8. Control del procedimiento**

Comprobación de las tiras de ensayo y de la manipulación:  
Analizar la solución patrón de sulfatos como se describe en el apartado 7.  
Notas adicionales, ver bajo [www.qa-test-kits.com](http://www.qa-test-kits.com).

**9. Nota**

**Cerrar de nuevo inmediatamente la caja tras la toma de la tira de ensayo.**

Merck KGaA, 64271 Darmstadt, Germany,  
Tel. +49(0)6151 72-2440  
[www.analytical-test-kits.com](http://www.analytical-test-kits.com)  
EMD Millipore Corporation, 290 Concord Road,  
Billerica, MA 01821, USA, Tel. +1-978-715-4321



## **APPENDIX 13**

### **PETROGRAPHIC ANALYSIS OF DEL CARMEN CHURCH**

#### **I. Introduction**

To provide precise recommendation treatments for the exterior restoration of the original exposed cement Stucco in the church, the petrographic analysis provides valuable information to quantify the extent of decay of the existing material. The petrographic analysis seeks to provide useful information related to the following questions:

- Characterization of Stucco
  - Confirm differences in stucco application and presence of pneumatically/spray applied stucco
  - Examination of substrates
  - Examination of stucco and layers
  - Confirm composition as outlined by the construction documents
  - Confirm coatings and surface treatments employed over the years
  - Voids
  
- Deterioration of Stucco finishes
  - Bonding between stucco and substrate
  - Carbonation
  - Cracks + Shrinkage Cracks + Thermal expansion
  - Salts – Sulfate actions
  - Acid and alkaline attacks

#### **II. Historical Context**

##### *The Puerto Rican Cement Factories – 1936-1963*

The establishment of a Cement Factory in Puerto Rico is among the most significant achievements of the Puerto Rico Reconstruction Administration (PRRA) related to the development of portland cement and concrete in the islands and the beginning of a new industrial era. In the first three decades of the twentieth century, imported Portland Cement from Europe and the United States supplied the demand for the local construction industry. As historian Guillermo Baralt (2008) discusses, the creation of a Cement factory in Puerto



Rico was in response to the rise in prices for cement since 1935 and the demand for the material for projects of the PRRA and other Federal related projects. Since the late 19th Century, there were conversations about establishing a Cement factory due to an abundance of natural calcic formations and other materials around the islands (Baralt, 2008).

The *Cementos de Puerto Rico* (the Puerto Rico Cement Company) was built in 1937 in the Barrio Amelia in Guaynabo, between Cataño and Guaynabo, in an area of natural calcic formations, readily accessible to the Ports of San Juan. The plant had a production capacity of up to 1.4 million bags of Portland Cement annually and was the first major public-owned factory, becoming the island's largest industrial factory. The factory was inaugurated in 1939 and later sold to the Puerto Rico Industrial Development Corporation (PRIDCO) in 1943. Renamed as the Puerto Rico Cement Corporation in 1940, the factory doubled its production in the incoming years. In 1948, the production rose to 4 million bags of Portland Cement. The Government of Puerto Rico, through the PRIDCO, incentivized the use of Portland Cement from the Puerto Rico Cement Corp. on some of its most iconic projects, such as the Caribe Hilton (Torres-Santiago, 2000).

Because of the high demand and federal restrictions on Portland Cement importations on the eve of World War II, the U.S. Department of War required more local Portland Cement for the anticipated massive military infrastructure projects around the islands. In 1941 the local Ferré Group, with the support of the U.S. Army, inaugurated the Ponce Cement Corporation, located in Ponce, in the southern part of the islands. Both factories guaranteed the supply for the military projects of the ongoing War. In the 1950s, both factories combined produced up to 6.8 million bags of Portland Cement, leading to surplus exportation. As part of the policies of Muñoz Marín and the PPDs Operation Bootstrap, all government-owned factories were sold or closed, including the Puerto Rico Cement Corp in Cataño. The Ferré Group bought the Puerto Rico Cement Corp., along with the other

public factories, in October 1950 (Bel, 2019). Later, in 1963, both Puerto Rico Cement and Ponce Cement merged, creating the Puerto Rican Cement Inc. (Baralt, 2008).

The Minerals Yearbook Reports between 1960 and 1963 provide insight into the building material production and consumption in Puerto Rico. In 1962, when the Del Carmen Church was built, the construction industry boom provided for a higher domestic demand for Portland Cement in the islands. Cement shipments accounted for 52% of the total mineral production in Puerto Rico, and all cement raw materials were mined near the plants of the two cement factories. Between 1960 and 1962, the two factories increased their internal production capacity, producing Portland cement initially by wet process only. Gypsum was imported from the Dominican Republic, and the production of clay for cement increased to 219 thousand short tons, a new record. Sand and gravel were produced from river valley deposits and beaches in all Senatorial Districts, while white high-grade silica sand for cement came from deposits west of San Juan. Limestone was readily available all over the island, and andesite, tuffaceous siltstone, and miscellaneous volcanic stone are widely available except in Arecibo. The sand was principally used for plaster/stucco for building constructions, among other projects.

### **III. Materials and Methods**

The petrographic analysis for cementitious based materials is a valuable tool for identifying the composition of the material like coarse and fine aggregates, cement types, additives, and admixtures. It is also useful for the mix of proportions, water/cement ratio, air void content, and signs and causes of deterioration. Furthermore, when evaluating Portland Cement renders, Petrography can additionally aid in determining the number of layers and their thickness, type, and source of aggregates, binders, mineral additions, and/or pigments, as well as identifying workmanship and deterioration issues (Ingham, 2013).

The proposed petrographic analysis aims to confirm the material composition, physic-mechanical properties (microstructure, pore sizes, binder, aggregates), as well as pathologies in the portland cement-renders at the Del Carmen Church. Twelve thin sections- render samples gathered from different parts of the building were analyzed (See Table 5.2).

The thin sections were sponsored by both the Center for the Analysis of Archaeological Materials and the Graduate Program in Historic Preservation and prepared by the National Petrographic Service, Inc. in Texas. After consultation with various professional concrete petrographers and sources, blue-dyed epoxy was selected for the thin sections. Also, oil was used for the thin sections to prevent the disappearance of salts in the petrofabric.

The petrographic analysis will follow standard references from the industry such as ASTM C295 – Petrographic Examination of Aggregates for Concrete, ASTM C856 – Petrographic Examination of Hardened Concrete, ASTM C1324 – Examination and Analysis of Hardened Masonry Mortar & ASTM C467 – Microscopical Determination of Parameters of the Air-Void System in Hardened Concrete. Poole & Sims' Concrete Petrography: A Handbook of Investigative Techniques, 2<sup>nd</sup> Ed. (2012), and Ingham's Geomaterials Under the Microscope (2013) are the two primary reference texts that would complement the report; both analyzed in the Annotated Bibliography.

#### **IV. Geological Context**

The Portland cement used in the construction of the Del Carmen Church probably came from one of the two cement factories in the islands:

- The Puerto Rico Cement Corp. just miles away from the building, in the Barrio Amelias between Cataño and Guaynabo on the north side of the islands

- The Ponce Cement Corp. just outside of downtown Ponce, on the south side of the islands.

The following geological maps showed the geological formations in both sites when the factories were localized (U.S. Geological Survey, 1977 & 1978). In Cataño, the site surrounding the Puerto Rico Cement Corp. has by calcareous strata formations, specifically with the presence of the Aymamón Limestone (Miocene). The description mentions the existence of fossiliferous, white to very pale orange, thick, very pure limestone.

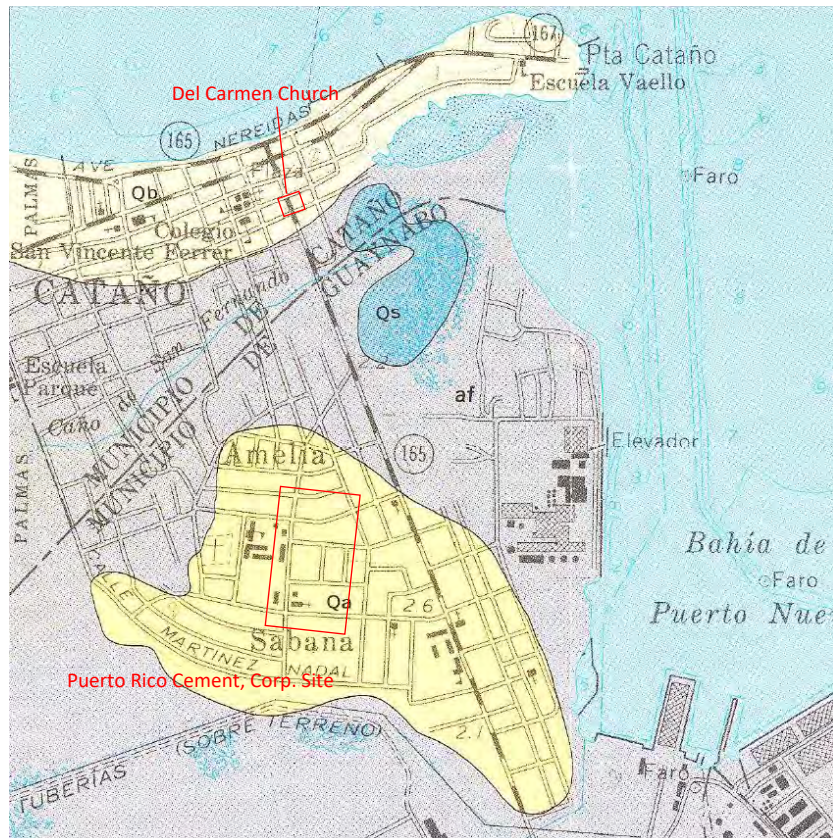


Fig. A13.1 – Location of the Puerto Rico Cement Corp. at the Barrio Amelia near Cataño. Source: M. H. Pease, Dr. and W. H. Monroe, Geologic Map of the San Juan Quadrangle, Puerto Rico, U.S. Geological Survey, 1977.

On the other side, the Ponce Cement is located near chalky limestone and upper clastic beds of Juana Diaz, between Ponce and the Magüeyez Urbano. This area is rich in pebbles, Gray to light-brown-fine to coarse sand, clay, and brown sandy clay.

Additionally, the site has soft chalk caliche, clayey chalk, fragments of bedded chalky limestone, calcite, sandstone, scattered grains of quartz, very pale orange to grayish orange crystalline calcarenite, an abundance of fossils, shells, and corals.

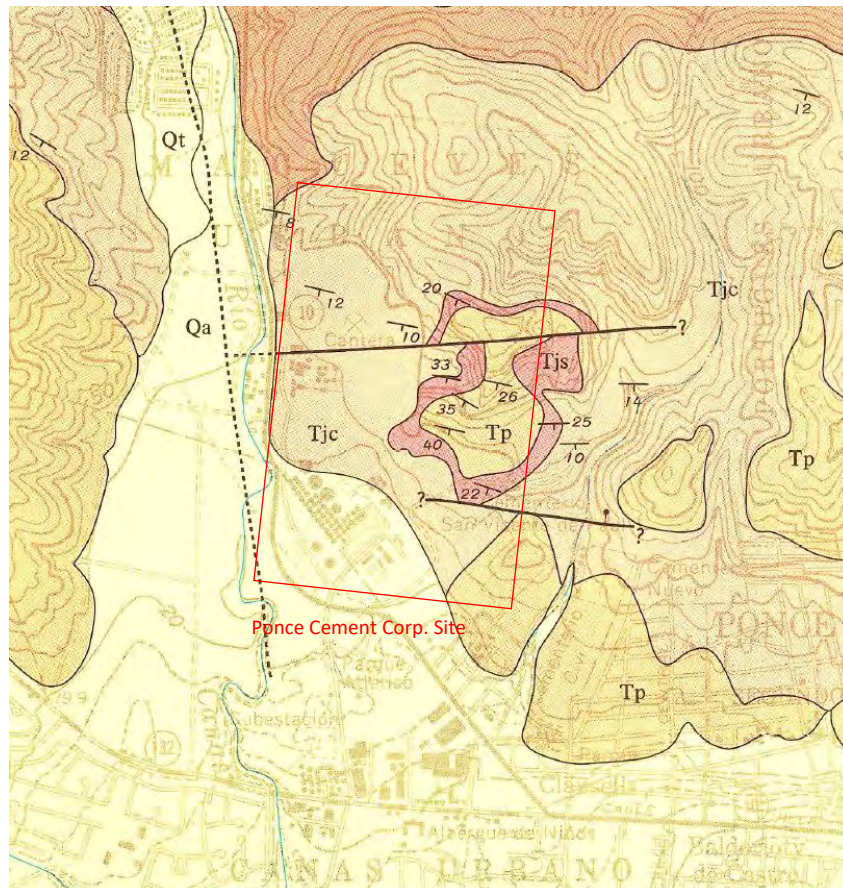


Fig. A13.2 – Location of the Ponce Cement Corp. Source: Krushensky, R. and Monroe, W. Geologic Map of the Peñuelas and Punta Cuchara Quadrangles, Puerto Rico, U.S. Geological Survey, 1978.

## V. Annotated Bibliography of Resources for Concrete Petrography

Selected Sources:

- Ingham, J., 2012. *Geomaterials Under the Microscope*. Mason Publishing, Ltd., London, pp. 75-121. – Chapter 5 – Concrete

Ingham's chapter 5 on Concrete presents an introductory overview of the petrographic examination of Concrete and related complementary techniques, covering both the phases of characterization and identifying deterioration of the material. The author starts

by presenting an overview of different needed elements for a proper petrographic analysis of Concrete: aggregates, Portland types of cement, additions, and admixtures, their properties, and classification types. The author discusses the identification of Water/Cement ratio, Air voids, and Workmanship; other elements in the characterization process, which aids in identifying the main components of the concrete mix. Ingham continues providing an overview of the main deterioration components of Concrete, and how to identify them in the petrographic analysis. Some specific deterioration patterns discussed are carbonation, cracking, frost attack and salt crystallization, sulfate attack by ground and seawater, alkali-aggregate reactions, acids, and fire damage. Lastly, Ingham complements the information provided with other chapters of the book, such as Petrography of aggregates, other concrete related products and mortars, plasters, and renders.

The chapter offers a valuable introduction for students and professionals in the construction industry who might consider the use of petrographic analysis to examine concrete and its components. Still, as an introductory reading, it does not provide in-depth knowledge of specific analytical techniques and additional considerations in petrographic analysis. More specialized references might be expected to complement the topics covered in the chapter for a proper petrographic report. The chapter is divided into two main parts, easy to follow through, and the author manages brilliantly complex information in a simplified and concise way. For the Del Carmen Church project, this reading is useful since it provides an overview of the analytical methods of the petrographic examination of concrete and set forth for the consultation of more complex and specialized references on the topic.

- Ingham, J., 2012. *Geomaterials Under the Microscope*. Mason Publishing, Ltd., London, pp. 152-158 – Chapter 8 – Mortar, Plaster & Renders.

Ingham's chapter 8 provides an overview of different types of Mortar, Plaster & Renders, and their examination using petrographic analysis. The chapter focuses on gypsum-based, lime-based, Portland cement-based, and other special mortars and renders. The author starts by outlining a brief summary of the properties of different binders used for mortars. Ingham presents a quick comparison of the petrographic examination techniques and standards used for concrete petrography and their application on the analysis of Portland cement-based renders and mortars. Like the Concrete Chapter, the Portland cement-based renders and mortar discussion is divided into two parts. The first part provides a summary of characterization techniques focusing heavily on the cement binder and the components of the mix, and the second part presents a very concise overview of the physical and chemical deterioration aspects. Lastly, Ingham complements the information provided with other chapters of the book, such as the petrography of aggregates, other concrete, and concrete-related products.

Because of the focus of this research, the Portland cement-based section of the chapter is only commented in this annotation. The chapter provides a limited but clear and concise introduction of the petrographic analysis of different mortars and renders in the construction industry, both contemporary and historic. Still, the author does not provide a great discussion on the decay patterns of Portland cement mortars and references the Concrete Chapter for further study. This shows how analytical methods are not so different. Since the thin sections and research questions on the Del Carmen Church project focus on the exterior Portland cement render and their deterioration, this chapter provides helpful insight into the current petrographic techniques for examining renders. The reading serves as an introductory reference and set forth to consult more complex and specialized texts on the topic.

- Jana, D., 2005. Concrete Petrography-Past, Present, and Future. 10<sup>th</sup> Euroseminar on Microscopy Applied to Building Materials, 1-22.

This article discusses the historical development and trends of petrography as an analytical tool for Concrete and other cementitious materials until 2005. The author starts differentiating traditional petrography from concrete petrography as a more specialized field of knowledge. The technique provides an enormous wealth of information in terms of characterization, quality, diagnostics, and deterioration of the material. The author discussed the stages of development of concrete petrography since 1882 through its different advancements in the twentieth century. Furthermore, the author makes the case of concrete petrography as a useful technical analysis tool listing its specific applications for the evaluation of Portland cement products and general masonry building materials. Lastly, an overview of standards and references until 2005, along with the expected qualifications of a concrete petrographer, is presented. The author also discussed some emerging analytical tools which aid the analysis of cementitious materials.

Since the article was published in a conference proceedings book, it is not structured as an organized journal article. This issue makes the text and arguments difficult to follow sometimes since it presents material that was already covered in previous sections repetitively without a continuous logic. Despite this issue, the author manages complex information in a simplified and concise way, easy to follow, especially for students and professionals without knowledge in the field. Reference of key people on the development of the technique, as well as the discussion on past standards and how they evolved, provides a useful perspective for people interested in exploring petrography from a historical perspective. This article helpful for the Del Carmen Church research since it presents a historical overview and introductory information for the technical application of concrete petrography. Also, a list of past and current reference documents is provided, including standards that can be reviewed during the petrographic analysis.



- Poole, A., Sims, I., 2016. Concrete Petrography: a handbook of investigative techniques, second ed. CRC Press-Taylor & Francis Group, Boca Ratón, FL, pp. 9-56. - Chapter 2 – Petrographic Equipment and Methods

Poole and Sims' 2<sup>nd</sup> Edition of Concrete Petrography constitutes almost a required reference for construction professionals and material scientists who want to use concrete petrography as an instrumental tool. In Chapter 2, both authors present an overview of methods and equipment used in concrete petrography. The first part of the chapter presents a discussion of the relevance of the petrographic methods and their use in the different investigations that can be summarized in two essential tables. These tables are a guide to petrographic methods appropriate for the identification and evaluation of particulate materials & a guide to petrographic methods relevant to the investigation of concrete, mortar, and related materials. The rest of the chapter presents and discussion of specific methods such as the use of low-power stereomicroscope, petrographic polarizing microscope, quantitative methods for component analysis, standard modal analysis methods, complementary and specialized techniques, thermal methods of analysis, chemical methods of analysis, and computer-aided petrographic methods. In the section on complementary and specialized techniques, the authors discuss in detail the use of petrographic examination with UV, scanning electron microscopy and microanalysis, elemental x-ray microanalysis, X-ray powder diffraction techniques, and the Fourier transform infrared spectroscopy.

Overall, the chapter provides valuable information in a clear and precise way for professionals and students who are considering concrete petrography as an analytical tool, along with specific components and procedures. Although it provides a quick overview of the different methods, more information should be consulted in the following chapters. Also, particular references might be expected to complement the topics covered in the chapter, especially for following chemical, thermal and computer-aided methods, as

well as complementary and specialized techniques. For the Del Carmen Church project, Chapter 2 provides valuable information on analytical methods that will be used to complement the petrographic report, such as X-ray powder diffraction and SEM.

- Poole, A., Sims, I., 2016. Concrete Petrography: a handbook of investigative techniques, second ed. CRC Press-Taylor & Francis Group, Boca Ratón, FL, pp. 103-216. – Chapter 4 – Composition of Concrete.

Poole & Sims' Chapter 4 provides an extensive overview of the use of petrography as an instrumental analytical method for the identification of mix proportions and constituents within hardened concrete, including cement types, aggregates, and additives/admixtures. The chapter is divided into two main sections. The first section discusses the materials characterization phase, including the identification of cement types, contents, and binders, the Hydrated cement phases, blended and special cements, building lime and cement/lime mixtures, and aggregate types and characteristics (including particle size and shapes). The second section focuses on what the authors have called the 'Principal mix parameters' in concrete, including water/cement (water/binder) ratio, aggregate/cement ratio, coarse-fine aggregate ratio, and void cement (including entrapped and entrained air voids). The second section also discusses the pros and cons of specific methodologies used for identifying these principal mix parameters. Lastly, the authors provide a review of the different methods and procedures to identify additions and admixtures such as mineral additions and pigments, ultra-fine additions, pigments, chemical admixtures, and fiber reinforcement types, and specific case studies.

In this chapter, Poole and Sims provide valuable information related to the standard petrographic characterization methods in a clear and precise way, including historical and technical data. The comparison and information in both the American and UK petrography standards are useful for professionals who need to refer to such documents in any petrographic report. For the Del Carmen Church project, Chapter 4 provides valuable

information on current characterization methods that will be used to complement the petrographic report, including an extensive discussion on general principles on microscopical methods and procedures, and interpretation of the findings and some common difficulties. Since the samples contain an unknown metallic aggregate, the discussion on page 260 related to steel fibers is particularly relevant.

- Poole, A., Sims, I., 2016. Concrete Petrography: a handbook of investigative techniques, second ed. CRC Press-Taylor & Francis Group, Boca Raton, FL, pp. 297-384. Chapter 5 – Appearance and textures of Cementitious materials.

Poole and Sims' Chapter 5 provides a discussion of the analysis of appearance and textures of concrete and other cementitious materials, focusing on some microstructure features such as carbonation, interfaces within concrete voids, and cracking. The chapter serves as an introduction to deterioration issues that would be discussed in succeeding chapters, specifically Chapter 6. The first part of the chapter discusses the microtexture of cementitious materials, the limitations of concrete petrography, and specific considerations for optical observations of the matrix of the hardened Portland Cement paste matrix. The rest of the chapter focuses on common features (mostly deleterious) that can be found within the microtexture of concrete, a discussion of causes, and technical methodologies to identify them. In the last section of the chapter, the authors provide an extensive review of cracking in concrete, including the differentiation of cracks resulting from tensile strain, structural and non-structural cracks, exterior and interior cracks, and the petrographic examination and the interpretation of crack systems. Lastly, Poole and Sims wrap up the discussion by presenting two useful tools for professionals using Petrography to evaluate cracks in cementitious materials: a petrographic examination checklist for cracks and crack systems and a general petrographic examination checklist of key features in concrete that should be recorded by the petrographer.

In this chapter, the authors provide useful information about the petrographic analysis of cementitious microtextures, specifications, and methods in a precise way, setting the reader for a more in-depth discussion of deterioration patterns in concrete. For the Del Carmen Church project, Chapter 5 provides useful information for the identification of fiber reinforcement in cement paste interfaces, as well as a brief introductory discussion on mortars and renders on pages 346 and 347. The information related to carbonation is particularly useful since there are identified carbonation issues in the building's exterior renders.

- Poole, A., Sims, I., 2016. Concrete Petrography: a handbook of investigative techniques, second ed. CRC Press-Taylor & Francis Group, Boca Raton, FL, pp. 385-612. – Chapter 6 – Examination of Deteriorated and damaged concrete.

Poole & Sims' Chapter 6 is essential reading for any professional or student considering using concrete petrography to identify durability issues and deterioration patterns in concrete or cementitious materials. In over 220 pages, the authors provide an extensive overview of common pathologies on concrete and technical considerations and methods for their identification. The chapter is divided into two main parts. The first part presents an overview of concrete durability, discussing current standards, generally related literature, and the methodology of investigating and classifying the durability of concrete. In this part, the authors discuss the durability of concrete concisely due to intrinsic and extrinsic reactions and the concept of external layer deterioration. Also, they provide a table for the classification of concrete deterioration based on the American Concrete Institute document ACI SP-100, useful especially for students. The second part of the chapter covers different deterioration patterns of cementitious materials and discussions of their behavior and technical identification methods. The specific deterioration patterns discussed in this chapter are plastic and drying shrinkage, corrosion of steel reinforcement, frost, and freeze-thaw action, sulfate actions, acid and alkaline

attacks, weathering and leaching, alkali-aggregate reaction (AAR), AAR involving carbonate aggregates, and damage from thermal cycling and fire.

In this Chapter, Poole and Sims provide an excellent discussion of deterioration patterns in a clear and precise way, suitable for both experienced and emerging professionals. The order in which the topics are covered makes it easy to follow the reading. Since most of the questions in the Del Carmen Church project involve deterioration and performance issues of the exterior Portland cement renders, this chapter is essential complementary reading. The first part discusses the durability of concrete, plastic and drying shrinkage, sulfate actions, and weathering and leaching are particularly useful sections for the petrographic investigation of the render samples.

- Poole, A., Sims, I., 2016. Concrete Petrography: a handbook of investigative techniques, second ed. CRC Press-Taylor & Francis Group, Boca Ratón, FL, pp. 647-668. – Chapter 8 – Portland Cement Mortar, Screeds, Renders, and Special Cements.

Chapter 8 provides an overview of the use of the concrete petrographic methodology for the application of other cementitious materials. Poole and Sims offer a comprehensive discussion of petrography for mortar and related materials, including characterization methods, standards, and specific considerations. The chapter covers specific reviews on floor screeds, including Terrazzo and tiled surface finishes, renders and cementitious plasters, jointing, and bedding mortars, special cement grouts, and sprayed concrete. The special cement and grouts section focuses on cementitious grouts, oil-well cements, and white and colored Portland cements and investigative techniques. The Renders section presents a discussion on specific petrographic methods of examination. In the last part of the chapter, the authors give a brief debate on cementitious repair materials, leveling compounds, and adhesive compounds and how to characterize them.

Poole and Sims' chapter on renders and mortars is one of the shortest sections of the book. Although it provides useful information on the characterization of mortars, renders, and special cements, it does not offer any substantial discussion on deterioration mechanisms specific to these cementitious materials. Since Chapter 6 provides an in-depth examination of deterioration issues, it also applies to renders and plasters. Still, the chapter is easy to follow through, and the authors manage the information in a simplified and concise way. For the Del Carmen Church, the discussions regarding Portland Cement renders and cementitious plasters on page 654, along with the properties and petrographic characterization methods of sprayed concrete on page 662, are key sources that would complement the petrographic analysis. Since the evaluation of samples in the Del Carmen Church focuses on the exterior cement renders -likely applied through different techniques-, this chapter will aid in confirming or denying the application of the exterior plaster with a gunite/sprayed method.

## **VI. Components of a Systematic Description of a Concrete Petrofabric**

Both Ingham (2012) and Poole & Sims (2016) provides an overview of the required components on a fabric description for Concrete and Portland Cement mortars and stucco. This methodology applies to Portland cement stucco. ASTM C1324 – *Standard Test Method for Examination and Analysis of Hardened Masonry Mortar* provides the specific standard practice for the petrographic analysis of mortars using ASTM C856 – *Standard Practice for Petrographic Examination of Hardened Concrete*, ASTM C295 – *Standard Guide for Petrographic Examination of Aggregates for Concrete*, and ASTM C457 – *Standard Test Method for Microscopical Determination of Parameters of the Air-Void System in Hardened Concrete*. Since there is no specific standard guide or practice for evaluating Portland cement stucco, the following methodology integrates essential considerations from the books and the standard practices and guides.

## 1. Visual examination of hand specimens

a. Following Practice ASTM C856, each sample/specimen should be examined in a Stereomicroscope. Some considerations for the examination include:

- Fine aggregates
  - i. Natural, manufactured, mixed or other type of sand.
  - ii. Homogeneous or heterogeneous.
  - iii. Surface texture
  - iv. Distribution, particle shape, grading and preferred orientation (as perceptible).
  
- Matrix
  - i. Color by comparison with National Research Council Rock Color Chart (1963)
  - ii. Color distribution – Mottled, even and/or gradational changes
  - iii. Fractures around and through aggregate
  - iv. Contact of matrix with aggregates – description, width, empty and filled
  - v. Cracks present, absent, preceding or result of specimen preparation
  - vi. Contamination
  - vii. Bleeding
  
- Air
  - i. Grading
  - ii. Proportion of spherical and nonspherical
  - iii. Nonspherical, ellipsoidal, irregular, disk shaped
  - iv. Color change from interior surface to matrix - Color differences between voids and mortars
  - v. Interior surface luster like rest of matrix, dull, shining
  - vi. Linings of voids - absent, rare, common, in most, complete, partial, colorless, colored, gel, other
  - vii. Underside voids or sheets of voids - uncommon, small, common, abundant
  
- Embedded items
  - i. Type, size, location, kinds of metal, other items.
  - ii. Clean or corroded?
  - iii. Cracks associated with embedded items?

b. The relative hardness using Moh's scale should be also evaluated with the hand specimen.

## 2. Matrix / Binder

Needed for the identification of Cement type. The methods of practice integrated in ASTM C856 are recommended to evaluate the binder.

- a. The thin section description includes the identification of type of cement - Pure vs. Composite:
  - Pure – Normal Portland Cement
  - Composite – Proportion of Portland Cement replaced by industrial product – blast furnace, slag, fly ash, natural pozzolana, limestone.
  
- b. Nature of relic cement grains - The description must also identify the nature of relict cement grains and the nature of portlandite crystallites which includes:
  - Size
  - Relative abundance
  - Distribution
  - Shape
  
- c. Nature of Portlandite Crystallites/Crystals - The description must also identify the nature of portlandite crystallites. Portlandite is Calcium Hydroxide ( $\text{Ca}(\text{OH})_2$ ) – Hydrated lime – occurs when water and lime merge. Identification of the form of Portlandite can tell us different information regarding the Water/Cement Ratio of mix and formation of cement. Three forms can be identified (Poole & Sims, 2013):
  - Small crystals
  - Coarse crystals
  - Recrystallized
  
- d. Examination of Unhydrated / Partially Hydrated clinker - Additionally, the microscopical examination of unhydrated/partially hydrated clinker (Portland cement clinker) help the identification of a Cement type by the amount of different unhydrated clinker of different phases in the matrix (if it's a pre or post-1950s Cement/normal vs. sulfate resisting Portland Cement, etc.). Table 3 in ASTM C856 provides specific guidance for the identification of the phases. These phases are:
  - Alite – Tricalcium silicate
  - Belite – Dicalcium Silicate
  - Aluminate – Tricalcium aluminate (usually not identified in Petrography, best seen in X-ray diffraction)
  - Ferrite – Tetracalcium aluminoferrite
  
- e. Depth of carbonation

### 3. Microstructure

In Concrete there is a consideration of the following:

- a. Air Voids
 

ASTM C1324 establishes that air voids must be characterized as defined in terminology ASTM C125 and/or Test Method ASTM C457. The characterization of air voids is often done by locations, dispositions and relative size. Three specific methods aid the identification of entrapped air voids and entrained air voids is done by the degree of compaction, manual



point-counting, or linear traverse measurements. As defined by Ingham (2012):

- Entrapped air voids – irregularly shaped air voids - < 1 mm and they are irregularly distributed in concrete and often increase in number and size towards the concrete surface.
- Entrained air voids – spherical shaped air voids – between 10 µm to 1 mm
- Visual estimation and compaction description based from Ingham (2012):

Excess voidage, %	Compaction
>0.5	Very good
>0.5-3.0	Good (normal for satisfactory quality structural concrete)
>3.0-5.0	Medium
>5.0-10.0	Poor
>10.0	Very poor
- For more specific and detailed procedures for determining the number of air voids follow procedures in ASTM C457.

b. Water/Cement Ratio – W/C

There are two standard petrographic methods: observing relative amounts of residual unhydrated cement grains or the use of fluorescence microscopy.

Also, consider apparent microporosity following:

- Low W/C - < 0.35
- Normal – 0.35-0.65
- High W/C - > 0.65

For a detailed discussion on methods see ASTM C856, p. 13.

c. Pop-Outs / Secondary deposits

Often product of contaminants – deterioration. These are conical cavities - semicircular or circular- on concrete surfaces that form by the increase of expansion of contaminants. ASTM C1324 recommends following the methods in Practice ASTM C856 to identify secondary products. ASTM C856 provides a specific table to aid the identification of secondary deposits in concrete.

d. Workmanship

- Degree of compaction – From > 0.5 and ranges up to > 10.0
- Mixing proportions
- Concrete petrography literature does not mention anything related to the importance of orientation of voids and inclusions.

e. Aggregate-cement interface – as discussed in Poole & Sims (2016) pp. 182-185

f. Cracks – usually described manually which must include the following features:

- Orientation
- Distribution
- Cracks occur in matrix or aggregate
- Details of the adjacent cement matrix
- Presence/density of cracking infillings
- Widths (and changes in width) following Ingham (2013):

<i>Crack type</i>	<i>Nominal width</i>	<i>Typical</i>
<i>length</i>		
Fine microcracks	<1 $\mu\text{m}$	A few
millimeters		
Microcracks	1-10 $\mu\text{m}$	1-30 mm
Fine cracks	10-100 $\mu\text{m}$	Up to 300
mm		
Cracks	100 $\mu\text{m}$ – 1 mm	Up to
several meters		
Large cracks	>1 mm wide	Up to
several meters		

- *Plastic shrinkage cracks* – in thin section appear as a linear series of tension gashes that run through the cement matrix and around aggregate particles
- *Crazing* – irregular network of fine cracks, often with close spacing
- *Microcracks by drying shrinkage* (thermal movement) – tend to meet at triple junctions in the paste to radiate from aggressive surfaces, run along parts of aggregate surfaces, and initiate on voids.
- Structural cracks – run through the aggregate and cement matrix.

#### 4. Aggregates

The analysis of Aggregates is done following methods of Guide ASTM C295 and Practice ASTM C856. Coarse and fine aggregates should be described separately.

##### a. Coarse Aggregates

- Types of grading: Continuous, Single size, Gap graded
- Particle shape
- Color
- Size Distribution
- Nominal Max. Size
- Orientation
- Internal structure – pores, space, packing of grains, cementation of grains
- Paste-aggregate bond – peripheral and internal cracks
- Mineral composition

##### b. Fine Aggregates

- Type of grading: Very well sorted, well-sorted, moderately sorted & poorly sorted
- Particle shape
- Color
- Size distribution
- Nominal Max. Size
- Orientation
- Paste-aggregate bond - peripheral and internal cracks
- Mineral composition

#### **5. Additions and Admixtures**

Identifying these in a microscope is more difficult, but some properties in Concrete can provide clues (i.e., number of voids and size).

- a. Admixtures – chemicals added to Concrete in Wet mix
- b. Additives – chemicals preblended with cement or dry cementitious mix
- c. Mineral additions – Naturally and industrially manufactured – other materials such as fibers, plastic or steel.

#### **6. Other considerations**

- a. Portland Cement-based stucco/plaster additionally considers the number of layers and layer thickness of the petrofabric.

Both ASTM C856 and ASTM C295 establishes the following as the minimum components for a Concrete Petrography Report:

- a. Location and orientation of the samples in the construction
- b. History of samples
- c. Physical and chemical tests made on samples with their results
- d. Description of samples and a report on mixture proportions, if available or if estimated, workmanship, construction practice, and original quality of the concrete in the construction, insofar as much information is available.
- e. Interpretation of the nature of the materials and the chemical and physical events that have led to the success or distress of the concrete.
- f. Recommendations for further petrographic, chemical, physical or geological investigations or supplementary petrographic investigations such as X-ray diffraction, differential thermal methods or other procedures.

### **VII. Petrographic Analysis**

## SAMPLE 1A-5

### 1. Visual examination of hand specimens

#### A. Fine aggregates (On Stucco only)

- i. Natural sand
- ii. Homogeneous – Small and big voids seen along homogeneous small sand grains
- iii. **Surface texture:** rough and almost uniform in front side (paint layer side)
- iv. **Distribution:** Well graded
- v. **Particle Shape:** rounded-flaky, rounded-equant, subrounded-elongate

#### B. Matrix

- i. **Color by comparison with National Research Council Rock Color Chart (1963)** - 2.5Y 1/8 & 2.5Y 6/2
- ii. **Color distribution – gradational changes:** Color not even, Lighter gray in the cut side, dark brownish gray in back side of the hand specimen.
- iii. **Fractures:** No fractures around or through aggregates
- iv. **Cracks:** No visible cracks
- v. **Contamination:** Contamination from specimen preparation
- vi. **Bleeding:** No visible bleeding

#### C. Air

- i. **Grading:** Poorly graded
- ii. Irregular, ellipsoidal, disk shaped
- iii. **Color change:** No color difference between the interior of voids and matrix
- iv. **Interior surface of Matrix:** Dull
- v. **Linings of voids:** Common and in most
- vi. **Underside voids or sheets of voids:** Common

#### D. Embedded items

- i. No embedded items

#### E. Relative Hardness - Moh's scale

- i. Between 4.0 and 5.0 – 4.5

### 2. Matrix / Binder

#### A. Type of cement: Pure – Normal Portland Cement

#### B. Nature of relic cement grains -

- i. Size – Small (< 20  $\mu\text{m}$ ), few medium-sized (20-60  $\mu\text{m}$ )
- ii. Distribution – Moderately sorted
- iii. Shape – Sub-rounded irregular, Sub-rounded elongate, Rounded quant

### **C. Examination of Unhydrated / Partially Hydrated clinker**

- i. Belite – Dicalcium Silicate is present
- ii. Ferrite – Tetracalcium aluminoferrite was preliminary confirmed

## **3. Microstructure**

### **A. Air Voids**

- i. Both entrapped air voids (irregularly shaped air voids - < 1 mm) and entrained air voids (spherical shaped air voids – between 10 µm to 1 mm) were seen.
- ii. **Proportion of spherical and nonspherical:**  
Spherical – 15%  
Nonspherical – 25%
- iii. Visual estimation and compaction description based from Ingham (2012): >10.0 – Very poor compaction

### **B. Water/Cement Ratio – W/C**

- i. Apparent microporosity - > 0.65 (High W/C)

### **C. Cracks** – usually described manually which must include the following features:

- i. Cracks occur in matrix
- ii. Details of the adjacent cement matrix – cracks on matrix and around aggregates
- iii. Length – between 2.21 mm and 1.72 mm
- iv. Presence/density of cracking infillings
  - Widths - Fine microcracks: <1 µm - A few millimeters
  - Plastic shrinkage cracks - appear as a linear series of tension gashes that run through the cement matrix and around aggregate particles

## **4. Aggregates**

### **A. Coarse Aggregates**

- i. Types of grading: Poorly sorted
- ii. Particle shape – Rounded equant
- iii. Color – Dark brown, light cream, brown
- iv. Nominal Max. Size – 3.46 mm & 4.1 mm
- v. Internal structure – pores (hydrated lime)
- vi. Paste-aggregate bond – peripheral cracks
- vii. Mineral composition – dolomitic hydrated lime (pure calcium oxide)

### **B. Fine Aggregates**

- i. Type of grading: Moderately sorted
- ii. Particle shape – Rounded elongate, Rounded elongate and flaky, Rounded, Sub rounded flaky, Well rounded equant, Sub rounded elongate
- iii. Color – Brown, yellowish-brown, cream, reddish-brown

- iv. Nominal Max. Size – between 1.33 mm and 0.15 mm
- viii. Paste-aggregate bond - peripheral cracks
- ix. Mineral composition – Organic shells – calcite and probably aragonite

**5. Additions and Admixtures**

- a. Admixtures – None
- b. Additives – None
- c. Mineral additions – None

**A. Other considerations**

- a. Number of layers and layer thickness:
  - Between 5.5 mm and 6.42 mm (paint layer between 0.2 and 0.3 mm)

	<b>SAMPLE 1A-5</b> <b>Sprayed stucco</b> <b>THIN SECTION – PPL</b>
	<b>ORIGIN: DEL CARMEN CHURCH</b> <b>ANALYZED: Aug 5-6<sup>th</sup>, 2020</b>
	<b>IMAGING: Nikon DS-Fi1 camera</b> <b>with NIS Elements BR software</b>
	<b>MICROSCOPE: Zeiss Axioscope A1</b> <b>OCULAR MAG: 2.5x</b>
	<b>OBJECTIVE: 4x</b> <b>ZOOM: n/a</b>
<b>TRINOCULAR MAG: 1x</b> <b>LIGHT SOURCE: Halogen</b>	
<b>FILTERS: Daylight</b> <b>COLOR TEMP: n / a</b>	

**NOTES:** Sample 1A-5 has a very high microporosity and very poor compaction.  
A1 – Biogenic Marine Sand & A2 – quartz - Fine Aggregate. Coarse aggregate includes Hydrated lime (not shown).  
B – Portland cement matrix  
C – Voids  
E – Paint Layer

	<b>SAMPLE 1A-5</b> <b>Sprayed stucco</b> <b>THIN SECTION – XPL</b>
	<b>ORIGIN: DEL CARMEN CHURCH</b> <b>ANALYZED: Aug 5-6<sup>th</sup>, 2020</b>
	<b>IMAGING: Nikon DS-Fi1 camera</b> <b>with NIS Elements BR software</b>
	<b>MICROSCOPE: Zeiss Axioscope A1</b> <b>OCULAR MAG: 2.5x</b>
	<b>OBJECTIVE: 4x</b> <b>ZOOM: n/a</b>
<b>TRINOCULAR MAG: 1x</b> <b>LIGHT SOURCE: Halogen</b>	
<b>FILTERS: Daylight</b> <b>COLOR TEMP: n / a</b>	

**NOTES:** Plastic shrinkage cracks on Sample 1A-5, which are seen through the matrix and around the aggregates.  
F – Microcracks

	<b>SAMPLE 1A-5</b> <b>Sprayed stucco</b> <b>THIN SECTION – PPL</b>
	<b>ORIGIN: DEL CARMEN CHURCH</b> <b>ANALYZED: Aug 5-6<sup>th</sup>, 2020</b>
	<b>IMAGING: Nikon DS-Fi1 camera</b> <b>with NIS Elements BR software</b>
	<b>MICROSCOPE: Zeiss Axioscope A1</b> <b>OCULAR MAG: 2.5x</b>
	<b>OBJECTIVE: 4x</b> <b>ZOOM: n/a</b>
	<b>TRINOCULAR MAG: 1x</b> <b>LIGHT SOURCE: Halogen</b>
<b>FILTERS: Daylight</b> <b>COLOR TEMP: n / a</b>	

**NOTES:** Full carbonation of the stucco - matrix in XPL is black.

	<b>SAMPLE 1A-1</b> <b>Sprayed stucco</b> <b>THIN SECTION – XPL</b>
	<b>ORIGIN: DEL CARMEN CHURCH</b> <b>ANALYZED: Aug 5-6<sup>th</sup>, 2020</b>
	<b>IMAGING: Nikon DS-Fi1 camera</b> <b>with NIS Elements BR software</b>
	<b>MICROSCOPE: Zeiss Axioscope A1</b> <b>OCULAR MAG: 2.5x</b>
	<b>OBJECTIVE: 4x</b> <b>ZOOM: n/a</b>
	<b>TRINOCULAR MAG: 1x</b> <b>LIGHT SOURCE: Halogen</b>
<b>FILTERS: Daylight</b> <b>COLOR TEMP: n / a</b>	

**NOTES:** Hydrated lime coarse aggregate grain in Sample 1A-1.



## **SAMPLE 1B**

### **1. Visual examination of hand specimens**

#### **A. Fine aggregates (On Stucco only)**

- i. Natural sand
- ii. Homogeneous – Small and medium voids seen along homogeneous small sand grains
- iii. **Surface texture:** Smooth on back and sides; rough and almost uniform on front (paint coating)
- iv. **Distribution:** Well graded
- v. **Particle Shape:** Rounded irregular, Sub rounded equant, Rounded equant, Rounded elongate

#### **B. Matrix**

- i. **Color by comparison with National Research Council Rock Color Chart (1963) - 2.5Y 8/1 & 2.5Y 7/1 (in between those two)**
- ii. **Color distribution – gradational changes:** Color not even, darkish gray on the Stucco area and light grey on substrate.
- iii. Contact of matrix with aggregates – uniform and filled with three voids in substrate around aggregate
- iv. **Fractures:** No fractures around or through aggregates
- v. **Cracks:** No visible cracks
- vi. **Contamination:** Contamination (Stain) from specimen preparation
- vii. **Bleeding:** No visible bleeding

#### **C. Air**

- i. **Grading:** Poorly graded
- ii. Nonspherical, spherical disk shaped, irregular
- iii. **Color change:** No color difference between the interior of voids and matrix
- iv. **Interior surface of Matrix:** Dull
- v. **Linings of voids:** Partial
- vi. **Underside voids or sheets of voids:** Common

#### **D. Embedded items**

- i. No embedded items

#### **E. Relative Hardness - Moh's scale**

- i. Between 4.0 and 5.0 – 4.5 & Substrate – 3.0

### **2. Matrix / Binder**

#### **A. Type of cement:** Pure – Normal Portland Cement

#### **B. Nature of relic cement grains -**

- i. Size – Small (< 20  $\mu\text{m}$ ), few medium-sized (20-60  $\mu\text{m}$ )
- ii. Distribution – Moderately sorted

- iii. Shape – Sub-rounded irregular, Sub-rounded elongate, Rounded quant

### **C. Examination of Unhydrated / Partially Hydrated clinker**

- i. Belite – Dicalcium Silicate is present
- ii. Ferrite – Tetracalcium aluminoferrite was preliminary confirmed

## **3. Microstructure**

### **A. Air Voids**

- i. Both entrapped air voids (irregularly shaped air voids - < 1 mm) and entrained air voids (spherical shaped air voids – between 10 µm to 1 mm) were seen.
- ii. **Proportion of spherical and nonspherical:**
  - Spherical – 15%
  - Nonspherical – 25%
- iii. Presence of well-rounded voids – difference from Samples 1A-1 and 1A-3
- iv. Visual estimation and compaction description based from Ingham (2012): >10.0 – Very poor compaction
- v. Voids up to 2.57 mm in length

### **B. Water/Cement Ratio – W/C**

- i. Apparent microporosity - > 0.65 (High W/C)

### **C. Cracks**

- i. Crack occur in matrix and through coarse aggregate
- ii. Details of the adjacent cement matrix – a crack on matrix, and around and through coarse aggregate
- iii. Length – between 0.68 mm and 0.99 mm
- iv. Presence/density of cracking infillings
  - Widths - Fine microcracks: <1 µm (Width) - A few millimeters length & Microcrack: 1-10 µm (Width) – 1 - 30 mm length
  - Plastic shrinkage cracks - appear as a linear series of tension gashes that run though the cement matrix and around aggregate particles
  - Structural crack – run through the aggregate and cement matrix (possible because of Sample preparation)
- vii. Some cracks filled with Calcium carbonate (CaCO<sub>3</sub>)

## **4. Aggregates**

### **A. Coarse Aggregates (On Stucco)**

- i. Types of grading: Poorly sorted
- ii. Particle shape – Rounded equant
- iii. Color – Dark brown, light cream, brown
- iv. Nominal Max. Size – 3.46 mm & 4.1 mm
- v. Internal structure – pores (hydrated lime)

- vi. Paste-aggregate bond – peripheral cracks and one crack through a coarse aggregate (big shell)
- vii. Mineral composition – dolomitic hydrated lime (pure calcium oxide) / Mineral composition in Concrete substrate: Silica, Quartz, feldspars, calcite and dolomite

#### **B. Fine Aggregates**

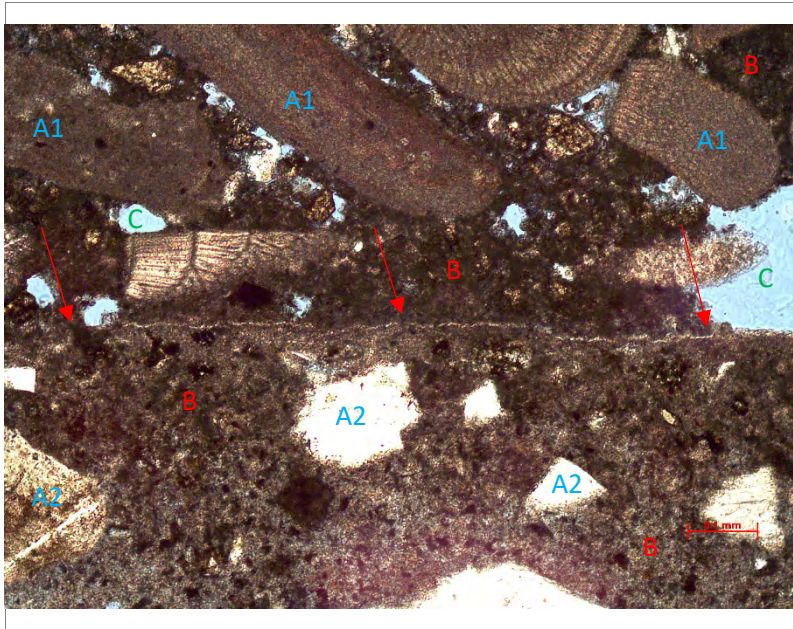
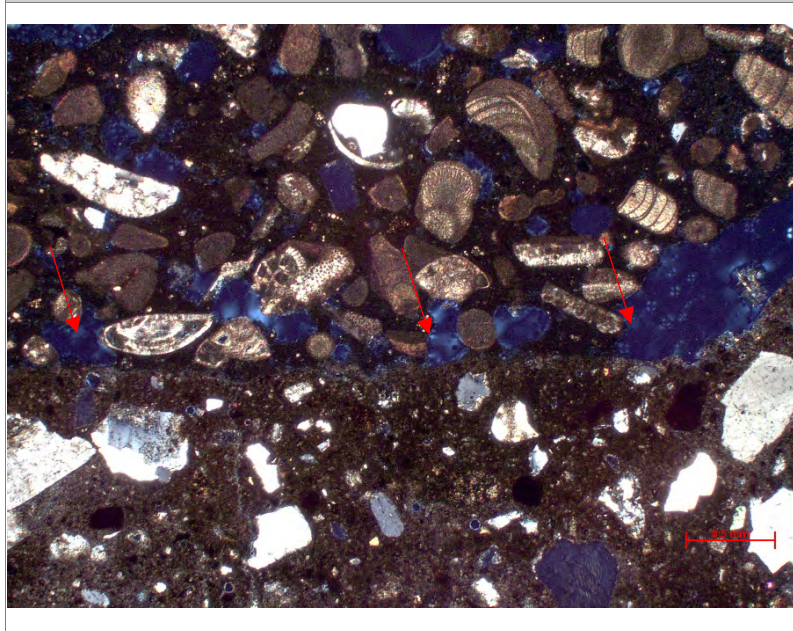
- i. Type of grading: Moderately sorted
- ii. Particle shape – Well rounded equant, Rounded equant, Well rounded flaky, Sub rounded flaky, Sub angular elongate, Rounded elongate
- iii. Color – Brown, yellowish-brown, cream, reddish-brown
- iv. Nominal Max. Size – between 0.60 mm and 0.16 mm
- viii. Paste-aggregate bond - peripheral cracks, some grains contains big pores
- ix. Mineral composition – Organic shells – calcite and probably aragonite

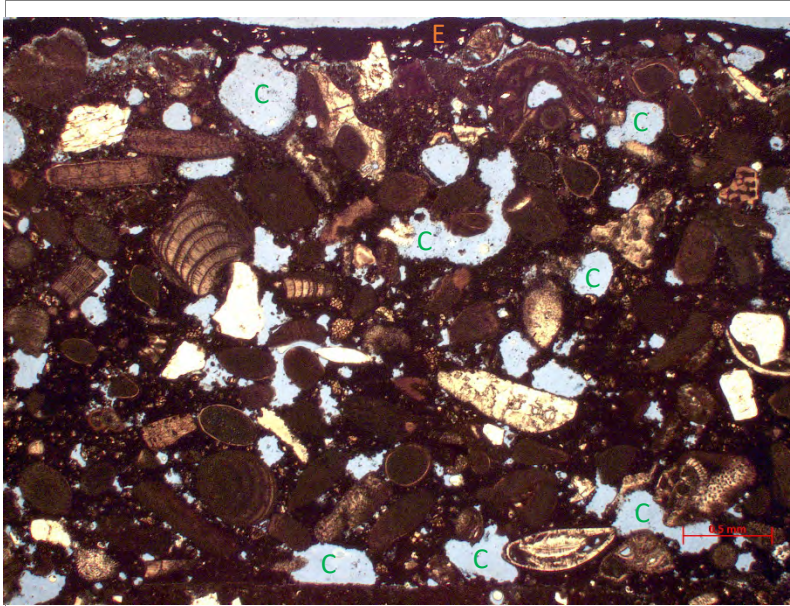
#### **5. Additions and Admixtures**

- a. Admixtures – None
- b. Additives – None
- c. Mineral additions – None

#### **A. Other considerations**

- A. Number of layers and layer thickness:
  - Stucco layer – 2.93 mm thick (paint layer between 0.21 and 0.29 mm)

	<p><b>SAMPLE 1B</b>  <b>Sprayed stucco and Substrate</b>  <b>THIN SECTION – PPL</b></p> <p><b>ORIGIN:</b> DEL CARMEN CHURCH  <b>ANALYZED:</b> Aug 6<sup>th</sup>, 2020</p> <p><b>IMAGING:</b> Nikon DS-Fi1 camera  with NIS Elements BR software</p> <p><b>MICROSCOPE:</b> Zeiss Axioscope A1  <b>OCULAR MAG:</b> 10x</p> <p><b>OBJECTIVE:</b> 4x  <b>ZOOM:</b> n/a</p> <p><b>TRINOCULAR MAG:</b> 1x  <b>LIGHT SOURCE:</b> Halogen</p> <p><b>FILTERS:</b> Daylight  <b>COLOR TEMP:</b> n / a</p>
<p><b>NOTES:</b> Bonding issues between Sprayed stucco and the poured-in-place concrete substrate.  A1 – Biogenic Marine Sand &amp; A2 – Rock fragments - Fine Aggregate.  B – Portland cement matrix  C – Voids</p>	
	<p><b>SAMPLE 1B</b>  <b>Sprayed stucco and Substrate</b>  <b>THIN SECTION – XPL</b></p> <p><b>ORIGIN:</b> DEL CARMEN CHURCH  <b>ANALYZED:</b> Aug 6<sup>th</sup>, 2020</p> <p><b>IMAGING:</b> Nikon DS-Fi1 camera  with NIS Elements BR software</p> <p><b>MICROSCOPE:</b> Zeiss Axioscope A1  <b>OCULAR MAG:</b> 2.5x</p> <p><b>OBJECTIVE:</b> 4x  <b>ZOOM:</b> n/a</p> <p><b>TRINOCULAR MAG:</b> 1x  <b>LIGHT SOURCE:</b> Halogen</p> <p><b>FILTERS:</b> Daylight  <b>COLOR TEMP:</b> n / a</p>
<p><b>NOTES:</b> Poor bonding between Sprayed stucco and the poured-in-place concrete substrate.</p>	



**SAMPLE 1B**  
**Sprayed stucco and Substrate**  
**THIN SECTION – PPL**

**ORIGIN:** DEL CARMEN CHURCH  
**ANALYZED:** Aug 6<sup>th</sup>, 2020

**IMAGING:** Nikon DS-Fi1 camera  
 with NIS Elements BR software

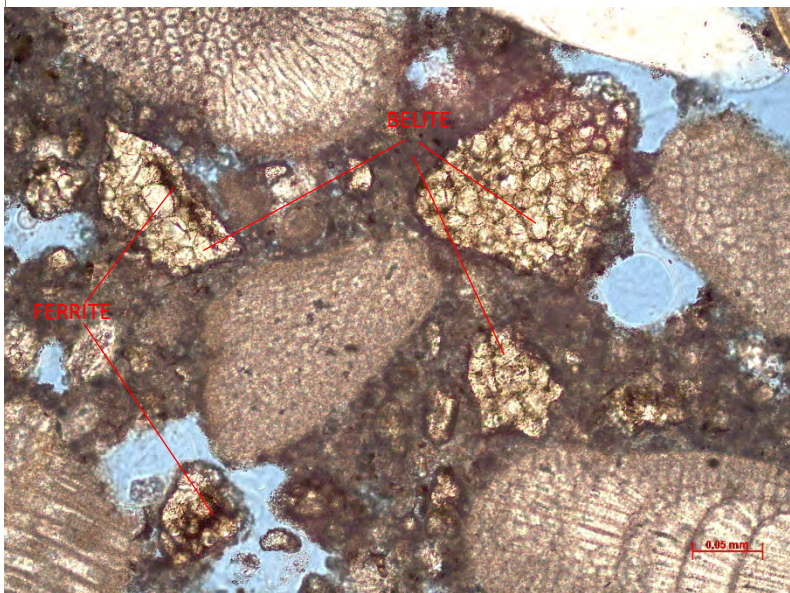
**MICROSCOPE:** Zeiss Axioscope A1  
**OCULAR MAG:** 2.5x

**OBJECTIVE:** 4x  
**ZOOM:** n/a

**TRINOCULAR MAG:** 1x  
**LIGHT SOURCE:** Halogen

**FILTERS:** Daylight  
**COLOR TEMP:** n / a

**NOTES:** Porosity on the Sprayed stucco shows very poor compaction.  
 C – Voids  
 E – Paint Layer



**SAMPLE 1B**  
**Sprayed stucco and Substrate**  
**THIN SECTION – XPL**

**ORIGIN:** DEL CARMEN CHURCH  
**ANALYZED:** Aug 6<sup>th</sup>, 2020

**IMAGING:** Nikon DS-Fi1 camera  
 with NIS Elements BR software

**MICROSCOPE:** Zeiss Axioscope A1  
**OCULAR MAG:** 20x

**OBJECTIVE:** 4x  
**ZOOM:** n/a

**TRINOCULAR MAG:** 1x  
**LIGHT SOURCE:** Halogen

**FILTERS:** Daylight  
**COLOR TEMP:** n / a

**NOTES:** Magnification of cement grains on the matrix. Ferrite and belite were preliminary identified.

## SAMPLE 2A-3

### 1. Visual examination of hand specimens

#### A. Fine aggregates (On Stucco only)

- i. Natural sand
- ii. Homogeneous – Some few small and medium voids on the matrix
- iii. **Surface texture:** Two sides smooth (from sample preparation), top side (paint later) rough and almost uniform, Back side shows rough concrete irregular surface and one side shows a rough and irregular surface.
- iv. **Distribution:** Moderately & Well graded
- v. **Particle Shape:** Rounded irregular, Sub rounded equant, Rounded elongate

#### B. Matrix

- i. **Color by comparison with National Research Council Rock Color Chart (1963)** - 2.5Y 8/1, 2.5Y 7/1 & 2.5Y 7/2 / Interior – one section of layer – 7.5YR 8/2
- ii. **Color distribution – gradational changes:** Color not even, smooth light grey on the side of specimen preparation, the substrate shows a light grey matrix and the rough side of the specimen shows a dark-grey brownish color with small pink (salmon)-grey spots.
- iii. Contact of matrix with aggregates – uniform and filled with three voids in substrate around aggregate
- iv. **Fractures:** No visible fractures around and through aggregates
- v. **Contact of matrix with aggregates** – uniform and filled, good strong bond
- vi. **Cracks:** One interior visible crack – between layer of stucco and concrete substrate
- vii. **Contamination:** Contamination (Stain) from specimen preparation, rust from embedded nail and iron filings, minor biofouling stain (black and green)
- viii. **Bleeding:** No visible bleeding

#### C. Air

- i. **Grading:** Well graded
- ii. **Shape** – rounded, equant, well rounded equant, Sub rounded equant
- iii. **Color change:** Small color change – grey-cream pink to light grey
- iv. **Interior surface of Matrix:** Dull
- v. **Linings of voids:** Common & complete
- vi. **Underside voids or sheets of voids:** Uncommon

#### D. Embedded items

- i. Iron filings – small, embedded in sample
- ii. Nail rusting - sample

#### E. Relative Hardness - Moh's scale

- i. Stucco – 4.0 & Substrate – 5.5

## 2. Matrix / Binder

### A. Type of cement: Pure – Normal Portland Cement

### B. Nature of relic cement grains -

- i. Size – Small ( $< 20 \mu\text{m}$ ), few medium-sized ( $20\text{-}60 \mu\text{m}$ )
- ii. Distribution – Moderately sorted
- iii. Shape – Rounded equant, Sub-rounded irregular, Sub-rounded elongate

### C. Examination of Unhydrated / Partially Hydrated clinker

- i. Belite – Dicalcium Silicate is present
- ii. Ferrite – Tetracalcium aluminoferrite was preliminary confirmed

## 3. Microstructure

### A. Air Voids

- i. Few entrapped air voids (irregularly shaped air voids -  $< 1 \text{ mm}$ ) were seen compared to entrained air voids (spherical shaped air voids – between  $10 \mu\text{m}$  to  $1 \text{ mm}$ ).
- ii. **Proportion of spherical and nonspherical:**
  - Spherical – 20%
  - Nonspherical – 7%
- iii. A majority of rounded equant and well rounded
- iv. Visual estimation and compaction description based from Ingham (2012):  $> 0.5 \%$  of excess voidage (very good compaction)
- v. Voids between  $0.15 \text{ mm}$  and  $0.69 \text{ mm}$  in length

### B. Water/Cement Ratio – W/C

- i. Apparent microporosity -  $< 0.35$  (Low W/C)

### C. Cracks

- i. One crack occurs in matrix and through fine aggregate. A crack was also seen on the concrete substrate which affects both the aggregates and matrix.
- ii. Details of the adjacent cement matrix – a crack around the matrix and through fine aggregate
- iii. Width of crack in Stucco – between  $0.01 \text{ mm}$  and  $0.05 \text{ mm}$
- iv. Presence/density of cracking infillings
  - Fine microcracks:  $< 1 \mu\text{m}$  (Width) - A few millimeters length & Microcrack:  $1\text{-}10 \mu\text{m}$  (Width) –  $1\text{-}30 \text{ mm}$  length (both to Stucco and Substrate)
  - Structural crack – run through the aggregate and cement matrix (possible because of Sample preparation in both Stucco and substrate)

#### **4. Aggregates**

##### **A. Coarse Aggregates (On Stucco)**

- i. Types of grading: Moderately sorted
- ii. Particle shape – Rounded irregular, Rounded equant, Sub-rounded irregular, Sub angular elongate
- iii. Color – Dark-reddish brown/black
- iv. Nominal Max. Size – Between 1.52 mm & 0.18 mm
- v. Internal structure – Filled, no pores
- vi. Paste-aggregate bond – good bonding, no voids or cracks seen
- vii. Mineral composition – Iron (Fe)

##### **B. Fine Aggregates (On Stucco)**

- i. Type of grading: Moderately sorted
- ii. Particle shape – Well rounded equant, Rounded equant, Well rounded flaky, Sub rounded flaky, Sub angular elongate, Rounded elongate
- iii. Color – Brown, yellowish-brown, cream, reddish-brown
- iv. Nominal Max. Size – between 0.87 mm and 0.16 mm
- viii. Paste-aggregate bond - peripheral cracks, some grains contains small pores
- ix. Mineral composition – Organic shells – calcite and probably aragonite

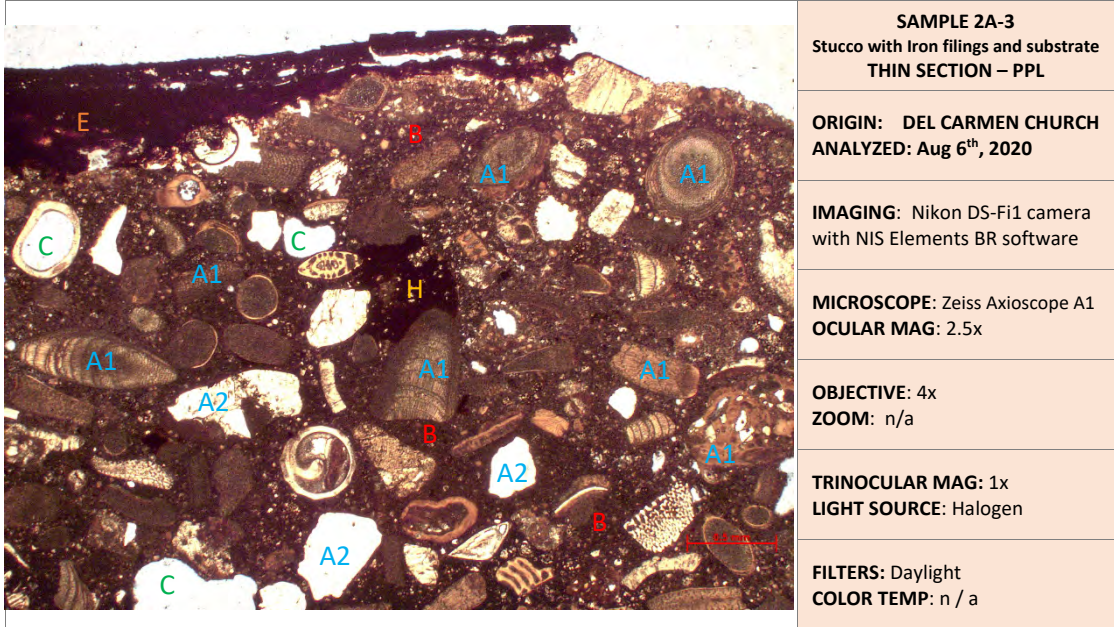
#### **5. Additions and Admixtures**

- a. Admixtures – None
- b. Additives – Iron filings
- c. Mineral additions – None

##### **A. Other considerations**

- A. Number of layers and layer thickness:
  - Stucco layer – 12.38 mm thick (paint layer 0.59 mm)





**SAMPLE 2A-3**  
Stucco with Iron filings and substrate  
**THIN SECTION – PPL**

**ORIGIN:** DEL CARMEN CHURCH  
**ANALYZED:** Aug 6<sup>th</sup>, 2020

**IMAGING:** Nikon DS-Fi1 camera  
with NIS Elements BR software

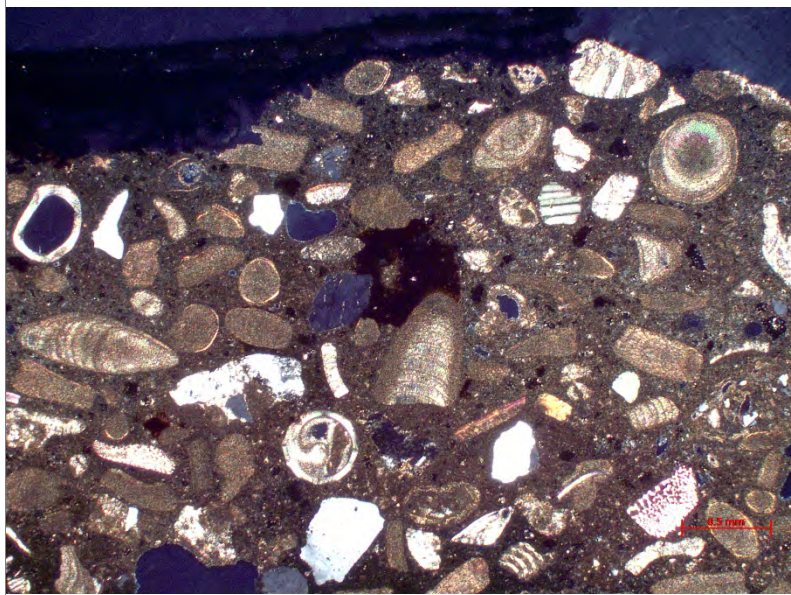
**MICROSCOPE:** Zeiss Axioscope A1  
**OCULAR MAG:** 2.5x

**OBJECTIVE:** 4x  
**ZOOM:** n/a

**TRINOCULAR MAG:** 1x  
**LIGHT SOURCE:** Halogen

**FILTERS:** Daylight  
**COLOR TEMP:** n / a

**NOTES:** A1 – Biogenic Marine Sand & A2 – Quartz and other rock fragments - Fine Aggregate.  
B – Portland cement matrix  
C – Voids  
E – Paint layer  
H – Iron filling



**SAMPLE 2A-3**  
Stucco with Iron filings and substrate  
**THIN SECTION – XPL**

**ORIGIN:** DEL CARMEN CHURCH  
**ANALYZED:** Aug 6<sup>th</sup>, 2020

**IMAGING:** Nikon DS-Fi1 camera  
with NIS Elements BR software

**MICROSCOPE:** Zeiss Axioscope A1  
**OCULAR MAG:** 2.5x

**OBJECTIVE:** 4x  
**ZOOM:** n/a

**TRINOCULAR MAG:** 1x  
**LIGHT SOURCE:** Halogen

**FILTERS:** Daylight  
**COLOR TEMP:** n / a

**NOTES:** Sample 2A-3 shows low-normal porosity and good compaction.

	<p><b>SAMPLE 2A-3</b> Stucco with Iron filings and substrate <b>THIN SECTION – XPL</b></p>
	<p><b>ORIGIN:</b> DEL CARMEN CHURCH <b>ANALYZED:</b> Aug 6<sup>th</sup>, 2020</p>
	<p><b>IMAGING:</b> Nikon DS-Fi1 camera with NIS Elements BR software</p>
	<p><b>MICROSCOPE:</b> Zeiss Axioscope A1 <b>OCULAR MAG:</b> 2.5x</p>
	<p><b>OBJECTIVE:</b> 4x <b>ZOOM:</b> n/a</p>
	<p><b>TRINOCULAR MAG:</b> 1x <b>LIGHT SOURCE:</b> Halogen</p>
<p><b>FILTERS:</b> Daylight <b>COLOR TEMP:</b> n / a</p>	

**NOTES:** Sample 2A-3 shows good bonding between poured-in-place concrete substrate and the troweled stucco.

	<p><b>SAMPLE 2A-3</b> Stucco with Iron filings and substrate <b>THIN SECTION – PPL</b></p>
	<p><b>ORIGIN:</b> DEL CARMEN CHURCH <b>ANALYZED:</b> Aug 6<sup>th</sup>, 2020</p>
	<p><b>IMAGING:</b> Galaxy A20 Phone Camera</p>
	<p><b>MICROSCOPE:</b> Zeiss Axioscope A1 <b>OCULAR MAG:</b> 2.5x</p>
	<p><b>OBJECTIVE:</b> 4x <b>ZOOM:</b> n/a</p>
	<p><b>TRINOCULAR MAG:</b> 1x <b>LIGHT SOURCE:</b> Halogen</p>
<p><b>FILTERS:</b> Daylight <b>COLOR TEMP:</b> n / a</p>	

**NOTES:** Differences of Stucco layers in Sample 2A-3.

## SAMPLE 2B

### 1. Visual examination of hand specimens

#### A. Fine aggregates

- i. Natural sand
- ii. Homogeneous – Small and large voids are seen along the homogeneous small sand grains and lime chunks
- iii. **Surface texture:** Top side – rough surface, partially uniform, side surfaces are smooth, bottom surfaces are smooth in substrate are and rough on stucco area, partially uniform.
- iv. **Distribution:** Well graded
- v. **Particle Shape:** rounded-elongate, sub rounded equant and rounded-elongate and flaky, rounded equant

#### B. Matrix

- i. **Color by comparison with National Research Council Rock Color Chart (1963)** - 2.5Y 7/1, 2.5Y 8/1
- ii. **Color distribution – gradational changes:** Color not even, Lighter gray in substrate side, brownish light grey on the stucco side.
- iii. **Fractures:** No visible cracks or fractures seen
- iv. **Contact of matrix with aggregates:** some uniform and filled, and voids around matrix are seen uniformly
- v. **Cracks:** One small crack visible on top of paint layer
- vi. **Contamination:** Stains from specimen preparation
- vii. **Bleeding:** No visible bleeding

#### C. Air

- i. **Grading:** Poorly graded
- ii. **Proportion of spherical and nonspherical:**
- iii. **Shape:** Sub angular elongate and flaky, Sub rounded flaky, Rounded irregular, Rounded equant, Angular elongate
- iv. **Color change:** Small change, lighter grey in the interior of the specimen compared to the exterior
- v. **Interior surface of Matrix:** Dull
- vi. **Linings of voids:** Partial
- vii. **Underside voids or sheets of voids:** Common & abundant

#### D. Embedded items

- i. No embedded items

#### E. Relative Hardness - Moh's scale

- i. Between 4.0 and 5.0 – 4.5 / Substrate – 3.0

### 2. Matrix / Binder

#### A. Type of cement: Pure – Normal Portland Cement

#### B. Nature of relic cement grains -

- i. Size – Small (< 20  $\mu\text{m}$ ), few medium-sized (20-60  $\mu\text{m}$ )
- ii. Distribution – Moderately sorted
- iii. Shape – Rounded equant, Sub-rounded irregular, Sub-rounded elongate

### **C. Examination of Unhydrated / Partially Hydrated clinker**

- i. Not assessed

## **3. Microstructure**

### **A. Air Voids**

- i. More entrapped air voids (irregularly shaped air voids - < 1 mm) were seen compared to entrained air voids (spherical shaped air voids – between 10  $\mu\text{m}$  to 1 mm).
- ii. **Proportion of spherical and nonspherical:**  
Spherical – 5%  
Nonspherical – 25%
- iii. Visual estimation and compaction description based from Ingham (2012): > 0.5 % of excess voidage (very good compaction)
- iv. Voids between 1.49 mm and 0.10 mm in length

### **B. Water/Cement Ratio – W/C**

- i. Apparent microporosity - > 0.65 (High W/C)

### **C. Cracks**

- i. Few fine microcracks (<1  $\mu\text{m}$ ) occurs through some fine aggregates on the borders of the sample.
- ii. Details of the adjacent cement matrix – No cracks visible in matrix.
- iii. Width of crack in Stucco – between 0.01 mm and 0.05 mm
- iv. Presence/density of cracking infillings
  - Fine microcracks: <1  $\mu\text{m}$  (Width) - A few millimeters length & Microcrack: 1-10  $\mu\text{m}$  (Width) – 1 - 30 mm length (both to Stucco and Substrate)
  - Structural crack – run through the aggregate and cement matrix (possible because of Sample preparation in both Stucco and substrate)

## **4. Aggregates**

### **A. Coarse Aggregates (On Stucco)**

- i. Types of grading: Poorly sorted
- ii. Particle shape – Rounded equant, Rounded elongate
- iii. Color – Dark brown, light cream, brown
- iv. Nominal Max. Size – Not assessed
- v. Internal structure – pores (hydrated lime)
- vi. Paste-aggregate bond – Large voids around matrix and coarse aggregates
- vii. Mineral composition – dolomitic hydrated lime (pure calcium oxide)

**B. Fine Aggregates (On Stucco)**

- i. Type of grading: Poorly sorted
- ii. Particle shape – Well rounded equant, Rounded equant, Well rounded flaky, Sub rounded flaky, Sub angular elongate, Rounded elongate
- iii. Color – Brown, yellowish-brown, cream, reddish-brown
- iv. Nominal Max. Size – between 1.11 mm and 0.24 mm
- viii. Paste-aggregate bond - some grains contains small pores
- ix. Mineral composition – Organic shells – calcite and probably aragonite

**5. Additions and Admixtures**

- a. Admixtures – None
- b. Additives – Iron filings
- c. Mineral additions – None

**A. Other considerations**

- A. Number of layers and layer thickness:
  - Stucco layer – No assessed

	<p><b>SAMPLE 2B</b> Sprayed stucco and substrate THIN SECTION – PPL</p>
	<p><b>ORIGIN:</b> DEL CARMEN CHURCH <b>ANALYZED:</b> Aug 6<sup>th</sup>, 2020</p>
	<p><b>IMAGING:</b> Nikon DS-Fi1 camera with NIS Elements BR software</p>
	<p><b>MICROSCOPE:</b> Zeiss Axioscope A1 <b>OCULAR MAG:</b> 2.5x</p>
	<p><b>OBJECTIVE:</b> 4x <b>ZOOM:</b> n/a</p>
	<p><b>TRINOCULAR MAG:</b> 1x <b>LIGHT SOURCE:</b> Halogen</p>
	<p><b>FILTERS:</b> Daylight <b>COLOR TEMP:</b> n / a</p>

**NOTES:** Bonding issues between the Sprayed stucco and poured-in-place concrete substrate  
A – Biogenic Marine Sand – Fine Aggregate. Coarse aggregate includes Hydrated lime (not shown).  
B – Portland cement matrix  
C – Voids  
G – Fine aggregate on Concrete substrate

	<p><b>SAMPLE 2B</b> Sprayed stucco and substrate THIN SECTION – XPL</p>
	<p><b>ORIGIN:</b> DEL CARMEN CHURCH <b>ANALYZED:</b> Aug 6<sup>th</sup>, 2020</p>
	<p><b>IMAGING:</b> Nikon DS-Fi1 camera with NIS Elements BR software</p>
	<p><b>MICROSCOPE:</b> Zeiss Axioscope A1 <b>OCULAR MAG:</b> 2.5x</p>
	<p><b>OBJECTIVE:</b> 4x <b>ZOOM:</b> n/a</p>
	<p><b>TRINOCULAR MAG:</b> 1x <b>LIGHT SOURCE:</b> Halogen</p>
	<p><b>FILTERS:</b> Daylight <b>COLOR TEMP:</b> n / a</p>

**NOTES:** Poor bonding between the Sprayed stucco and poured-in-place concrete substrate

	<p><b>SAMPLE 2B</b>  Sprayed stucco and substrate  <b>THIN SECTION – PPL</b></p>
	<p><b>ORIGIN:</b> DEL CARMEN CHURCH  <b>ANALYZED:</b> Aug 6<sup>th</sup>, 2020</p>
	<p><b>IMAGING:</b> Nikon DS-Fi1 camera  with NIS Elements BR software</p>
	<p><b>MICROSCOPE:</b> Zeiss Axioscope A1  <b>OCULAR MAG:</b> 10x</p>
	<p><b>OBJECTIVE:</b> 4x  <b>ZOOM:</b> n/a</p>
	<p><b>TRINOCULAR MAG:</b> 1x  <b>LIGHT SOURCE:</b> Halogen</p>
	<p><b>FILTERS:</b> Daylight  <b>COLOR TEMP:</b> n / a</p>

**NOTES:** Bonding issues between the Sprayed stucco and poured-in-place concrete substrate

	<p><b>SAMPLE 2B</b>  Sprayed stucco and substrate  <b>THIN SECTION – XPL</b></p>
	<p><b>ORIGIN:</b> DEL CARMEN CHURCH  <b>ANALYZED:</b> Aug 6<sup>th</sup>, 2020</p>
	<p><b>IMAGING:</b> Nikon DS-Fi1 camera  with NIS Elements BR software</p>
	<p><b>MICROSCOPE:</b> Zeiss Axioscope A1  <b>OCULAR MAG:</b> 10x</p>
	<p><b>OBJECTIVE:</b> 4x  <b>ZOOM:</b> n/a</p>
	<p><b>TRINOCULAR MAG:</b> 1x  <b>LIGHT SOURCE:</b> Halogen</p>
	<p><b>FILTERS:</b> Daylight  <b>COLOR TEMP:</b> n / a</p>

**NOTES:** Bonding issues between the Sprayed stucco and poured-in-place concrete substrate

## SAMPLE 3B

### 1. Visual examination of hand specimens

#### A. Fine aggregates (On Stucco only)

- i. Natural sand
- ii. Homogeneous – Small and big voids seen along homogeneous small sand grains
- iii. **Surface texture:** Top side has a partially uniform, rough texture; one side has a smooth texture (because of specimen preparation); one side has a rough and irregular surface and the bottom side has a smooth and partially uniform surface.
- iv. **Distribution:** Well graded
- v. **Particle Shape:** Rounded-flaky, Rounded-equant, Rounded irregular, Sub angular irregular

#### B. Matrix

- i. **Color by comparison with National Research Council Rock Color Chart (1963)** - 2.5Y 1/8 & 2.5Y 7/1, 2.5Y 6/1 & 10YR 8/1
- ii. **Color distribution – gradational changes:** Color not even, Substrate has a light grey-cream color, the Stucco features a grey and brownish-grey color. Some areas are lighter than others.
- iii. **Fractures:** No visible cracks or fractures around or through aggregates
- iv. **Contact of matrix with aggregates:** Uniform and filled except for some voids near the fine aggregates.
- v. **Cracks:** Several small cracks in top (paint) stucco layer.
- vi. **Contamination:** White minor stain on the painted top layer in Stucco and small intense cream color with a crystal near a coarse aggregate on the substrate.
- vii. **Bleeding:** No visible bleeding

#### C. Air

- i. **Grading:** Well graded
- ii. **Shape:** Angular elongate, Rounded irregular, Rounded equant
- iii. **Color change:** No color difference between the interior of voids and matrix
- iv. **Interior surface of Matrix:** Dull
- v. **Linings of voids:** Partial
- vi. **Underside voids or sheets of voids:** Common

#### D. Embedded items

- i. No embedded items

#### E. Relative Hardness - Moh's scale

- i. Stucco between 6.0 and 7.0 – 6.5 / Substrate – 6.5



## 2. Matrix / Binder

### A. Type of cement: Pure – Normal Portland Cement

### B. Nature of relic cement grains -

- i. Size – Small ( $< 20 \mu\text{m}$ ), few medium-sized (20-60  $\mu\text{m}$ )
- ii. Distribution – Well sorted
- iii. Shape – Sub-rounded irregular, Sub-rounded elongate, Rounded quant

### C. Examination of Unhydrated / Partially Hydrated clinker

- i. Belite – Dicalcium Silicate is present
- ii. Ferrite – Tetracalcium aluminoferrite was preliminary confirmed

## 3. Microstructure

### A. Air Voids (On Stucco)

- i. Both entrapped air voids (irregularly shaped air voids -  $< 1 \text{ mm}$ ) and entrained air voids (spherical shaped air voids – between 10  $\mu\text{m}$  to 1 mm) were seen.
- ii. Approx. Length – Between 1.87 mm and 0.05 mm
- iii. **Proportion of spherical and nonspherical:**  
Spherical – 15%  
Nonspherical – 25%
- iv. Visual estimation and compaction description based from Ingham (2012):  $>5.0 - 10.0$  – poor compaction

### B. Water/Cement Ratio – W/C

- i. Apparent microporosity -  $> 0.65$  (High W/C) (On Stucco)

### C. Cracks – usually described manually which must include the following features:

- i. Very fine microcracks occur in matrix, initiate from voids
- ii. Details of the adjacent cement matrix – cracks on matrix (between later 1 and layer 2) and around aggregates.
- iii. Length – Not assessed
- iv. Presence/density of cracking infillings
  - Widths - Fine microcracks:  $<1 \mu\text{m}$  - A few millimeters
  - Plastic shrinkage cracks - appear as a linear series of tension gashes that run through the cement matrix and around aggregate particles

## 4. Aggregates

### A. Coarse Aggregates

- i. Types of grading: Poorly sorted
- ii. Particle shape – Rounded equant (hydrated lime), Angular elongate, Very angular irregular (remaining coarse aggregate)
- iii. Color – Dark brown, light cream, brown, white, gray, black
- iv. Nominal Max. Size – 2.27 mm & 2.07 mm

- v. Internal structure – Some small pores on hydrated lime
- vi. Paste-aggregate bond – Enough cement matrix to bind coarse aggregate
- vii. Mineral composition – dolomitic hydrated lime (pure calcium oxide), Quartz, Feldspar and other stone fragments (2<sup>nd</sup> coat- Substrate?)

**B. Fine Aggregates**

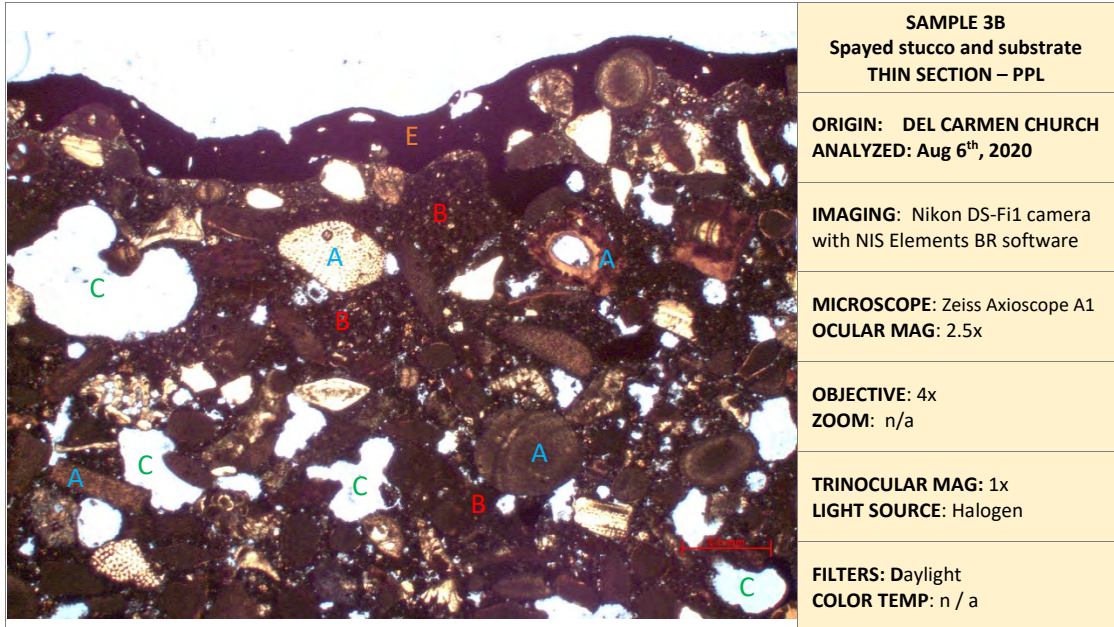
- i. Type of grading: Poorly sorted
- ii. Particle shape – Well rounded elongate, Rounded elongate, Rounded elongate and flaky, Rounded, Well rounded equant, Sub rounded elongate, Well rounded elongate and flaky
- iii. Color – Brown, yellowish-brown, cream, reddish-brown, light cream, white, black
- iv. Nominal Max. Size – between 1.84 mm and 0.19 mm
- viii. Paste-aggregate bond - peripheral cracks
- ix. Mineral composition – Organic shells – calcite and probably aragonite

**5. Additions and Admixtures**

- a. Admixtures – None
- b. Additives – None
- c. Mineral additions – None

**A. Other considerations**

- A. Number of layers and layer thickness:
  - First Stucco coat – 4.39 mm (paint layer between 0.2 and 0.3 mm)
  - Second coat with coarse aggregate-Substrate? - not assessed



**SAMPLE 3B**  
Spayed stucco and substrate  
THIN SECTION – PPL

**ORIGIN:** DEL CARMEN CHURCH  
**ANALYZED:** Aug 6<sup>th</sup>, 2020

**IMAGING:** Nikon DS-Fi1 camera  
with NIS Elements BR software

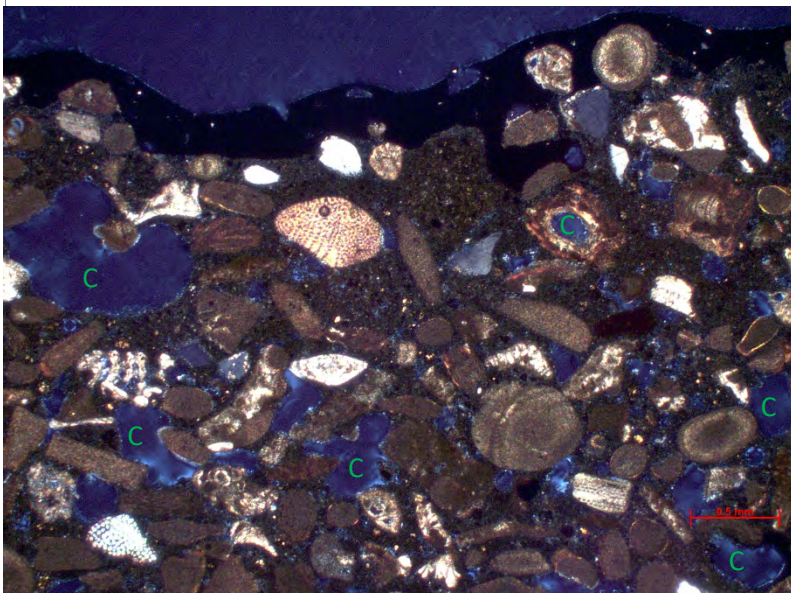
**MICROSCOPE:** Zeiss Axioscope A1  
**OCULAR MAG:** 2.5x

**OBJECTIVE:** 4x  
**ZOOM:** n/a

**TRINOCULAR MAG:** 1x  
**LIGHT SOURCE:** Halogen

**FILTERS:** Daylight  
**COLOR TEMP:** n / a

**NOTES:** A – Biogenic Marine Sand – Fine Aggregate. Coarse aggregate includes Hydrated lime (not shown).  
B – Portland cement matrix  
C – Voids  
E – Paint Layer



**SAMPLE 3B**  
Spayed stucco and substrate  
THIN SECTION – XPL

**ORIGIN:** DEL CARMEN CHURCH  
**ANALYZED:** Aug 6<sup>th</sup>, 2020

**IMAGING:** Nikon DS-Fi1 camera  
with NIS Elements BR software

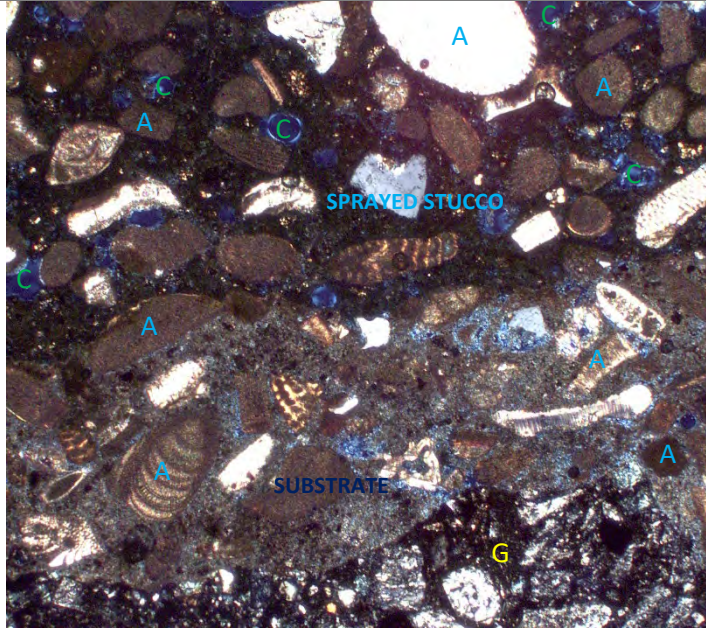
**MICROSCOPE:** Zeiss Axioscope A1  
**OCULAR MAG:** 2.5x

**OBJECTIVE:** 4x  
**ZOOM:** n/a

**TRINOCULAR MAG:** 1x  
**LIGHT SOURCE:** Halogen

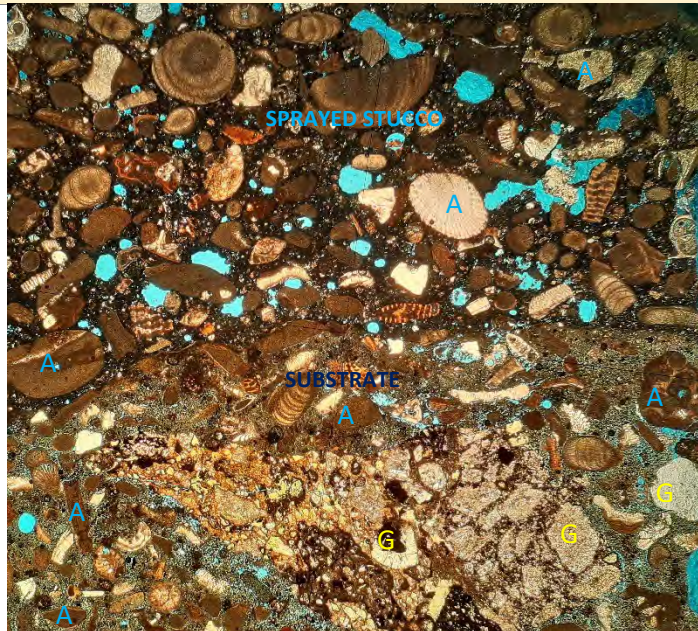
**FILTERS:** Daylight  
**COLOR TEMP:** n / a

**NOTES:** Porosity and medium compaction of Sample 5.  
C – Voids



<b>SAMPLE 3B</b> Spayed stucco and substrate THIN SECTION – XPL
<b>ORIGIN:</b> DEL CARMEN CHURCH <b>ANALYZED:</b> Aug 6 <sup>th</sup> , 2020
<b>IMAGING:</b> Nikon DS-Fi1 camera with NIS Elements BR software
<b>MICROSCOPE:</b> Zeiss Axioscope A1 <b>OCULAR MAG:</b> 2.5x
<b>OBJECTIVE:</b> 4x <b>ZOOM:</b> n/a
<b>TRINOCULAR MAG:</b> 1x <b>LIGHT SOURCE:</b> Halogen
<b>FILTERS:</b> Daylight <b>COLOR TEMP:</b> n / a

**NOTES:** Layer differences on Sample 3B  
 A – Biogenic Marine Sand – Fine Aggregate.  
 C – Voids  
 G – Coarse aggregate in Substrate - Rock fragment



<b>SAMPLE 3B</b> Spayed stucco and substrate THIN SECTION – PPL
<b>ORIGIN:</b> DEL CARMEN CHURCH <b>ANALYZED:</b> Aug 6 <sup>th</sup> , 2020
<b>IMAGING:</b> Galaxy A20 Camera Phone
<b>MICROSCOPE:</b> Zeiss Axioscope A1 <b>OCULAR MAG:</b> 2.5x
<b>OBJECTIVE:</b> 4x <b>ZOOM:</b> n/a
<b>TRINOCULAR MAG:</b> 1x <b>LIGHT SOURCE:</b> Halogen
<b>FILTERS:</b> Daylight <b>COLOR TEMP:</b> n / a

**NOTES:** Layer differences on Sample 3B  
 A – Biogenic Marine Sand – Fine Aggregate.  
 C – Voids  
 G – Coarse aggregate in Substrate – Rock fragments

## SAMPLE 4-1

### 1. Visual examination of hand specimens

#### A. Fine aggregates

- i. Natural sand
- ii. Homogeneous – Small and big voids seen along homogeneous small sand grains
- iii. **Surface texture:** Top side has a rough texture, not uniform; one side has a smooth texture (because of specimen preparation); one side has a rough and irregular surface and the bottom side has a rough and partially uniform surface.
- iv. **Distribution:** Well graded
- v. **Particle Shape:** Rounded elongate & flaky, Rounded equant, Rounded irregular, Sub rounded equant, Rounded flaky

#### B. Matrix

- i. **Color by comparison with National Research Council Rock Color Chart (1963)** - 2.5Y 1/8 & 2.5Y 7/1, 2.5Y 7/2, 10YR 8/2, & 10 YR 8/1. For the paint layer - 10YR 7/1.
- ii. **Color distribution – gradational changes:** Color not even, coats clearly defined: a grey-brown cream coat, a light grey coat and a grey coat.
- iii. **Fractures:** No fractures around or through aggregates
- iv. **Contact of matrix with aggregates** – Uniform and filled
- v. **Cracks:** No visible cracks
- vi. **Contamination:** Minor stain from specimen preparation
- vii. **Bleeding:** No visible bleeding

#### C. Air

- i. **Grading:** Well graded
- ii. **Shape:** Well-rounded equant, Rounded equant, Sub rounded equant
- iii. **Color change:** No color difference between the interior of voids and matrix
- iv. **Interior surface of Matrix:** Dull
- v. **Linings of voids:** Complete
- vi. **Underside voids or sheets of voids:** Uncommon

#### D. Embedded items

- i. No embedded items

#### E. Relative Hardness - Moh's scale

- i. Between 8.0 and 9.0 –8.5

## 2. Matrix / Binder

### A. Type of cement: Pure – Normal Portland Cement

### B. Nature of relic cement grains -

- i. Size – Small ( $< 20 \mu\text{m}$ ), few medium-sized (20-60  $\mu\text{m}$ )
- ii. Distribution – Moderately sorted
- iii. Shape – Rounded equant, Sub-rounded irregular, Sub-rounded elongate

### C. Examination of Unhydrated / Partially Hydrated clinker

- i. Belite – Dicalcium Silicate is present
- ii. Ferrite – Tetracalcium aluminoferrite was preliminary confirmed

## 3. Microstructure

### A. Air Voids

- i. Both entrapped air voids (irregularly shaped air voids -  $< 1 \text{ mm}$ ) and entrained air voids (spherical shaped air voids – between 10  $\mu\text{m}$  to 1 mm) were seen.
- ii. **Proportion of spherical and nonspherical:**  
Spherical – 20%  
Nonspherical – 15%
- iii. Width – Between 1.49 mm & 0.09 mm
- iv. Visual estimation and compaction description based from Ingham (2012):  $>0.5 - 3.0 \%$  – Good compaction

### B. Water/Cement Ratio – W/C

- i. Apparent microporosity – 0.35-0.65 (Normal W/C)

### C. Cracks – usually described manually which must include the following features:

- i. Cracks occur in matrix and through fine aggregates
- ii. Details of the adjacent cement matrix – cracks on matrix and through and around aggregates
- iii. Length – between 2.5 mm and 0.44 mm
- iv. Presence/density of cracking infillings
  - Widths - Fine microcracks:  $<1 \mu\text{m}$  - A few millimeters & Microcracks – 1-10  $\mu\text{m}$
  - Plastic shrinkage cracks - appear as a linear series of tension gashes that run through the cement matrix and around aggregate particles
  - Cracks by Sulfate attack

## 4. Aggregates

### A. Coarse Aggregates

- i. Types of grading: Poorly sorted
- ii. Particle shape – Rounded equant
- iii. Color – Dark brown, brown

- iv. Nominal Max. Size – Not assessed
- v. Internal structure – pores (hydrated lime)
- vi. Paste-aggregate bond – Matrix and fine aggregate surround the coarse aggregate, strong bond
- vii. Mineral composition – dolomitic hydrated lime (pure calcium oxide)

**B. Fine Aggregates**

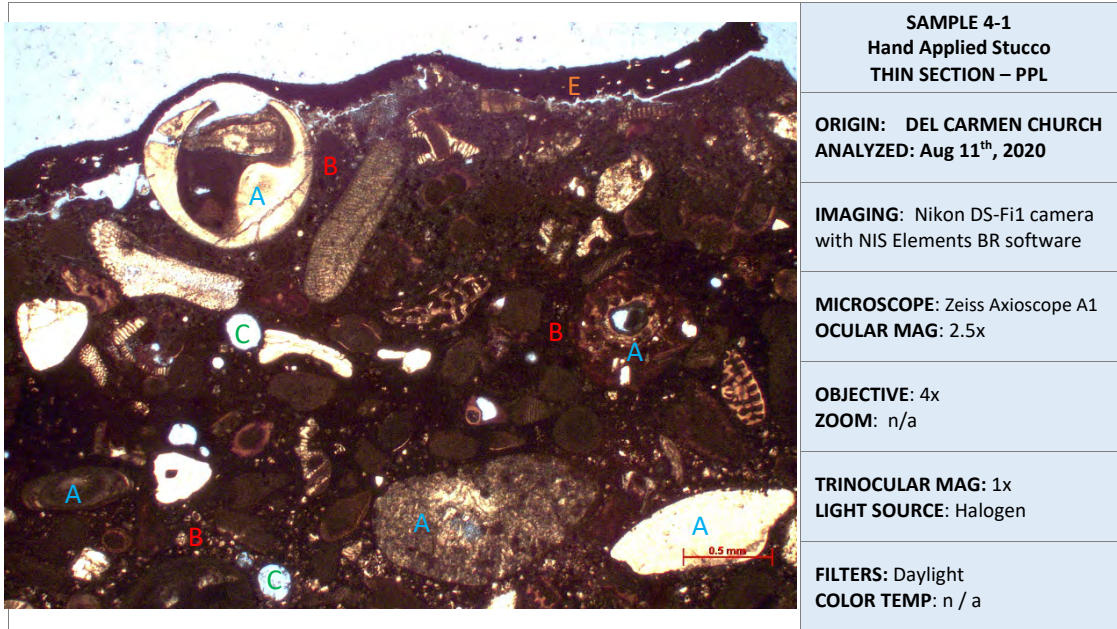
- i. Type of grading: Moderately sorted
- ii. Particle shape – Rounded elongate, Rounded elongate and flaky, Rounded, Sub rounded flaky, Well rounded equant, Sub rounded elongate
- iii. Color – Brown, yellowish-brown, cream, reddish-brown
- iv. Nominal Max. Size – between 1.95 mm and 0.09 mm
- viii. Paste-aggregate bond - peripheral cracks
- ix. Mineral composition – Organic shells – calcite and probably aragonite

**5. Additions and Admixtures**

- a. Admixtures – None
- b. Additives – None
- c. Mineral additions – None

**A. Other considerations**

- A. Number of layers and layer thickness:
  - Not assessed
  - Paint layer between 0.24 and 0.6 mm



**SAMPLE 4-1**  
**Hand Applied Stucco**  
**THIN SECTION – PPL**

**ORIGIN:** DEL CARMEN CHURCH  
**ANALYZED:** Aug 11<sup>th</sup>, 2020

**IMAGING:** Nikon DS-Fi1 camera  
 with NIS Elements BR software

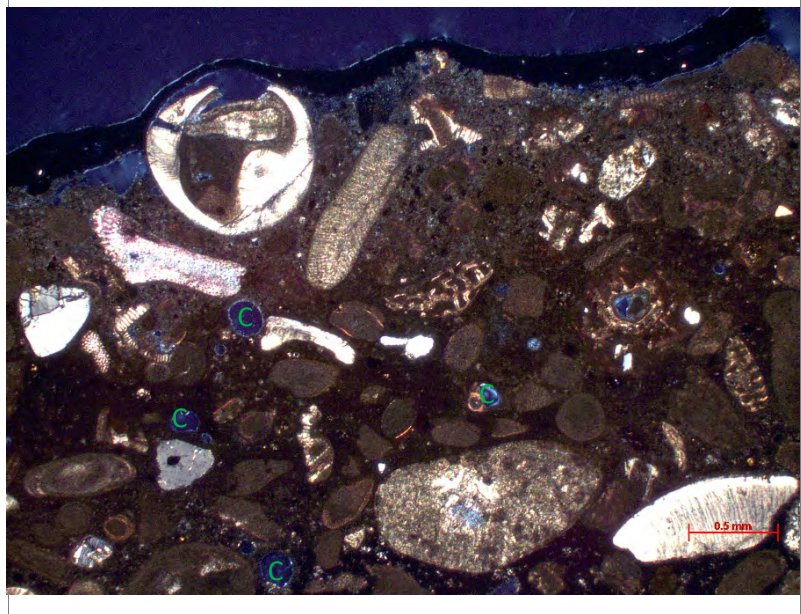
**MICROSCOPE:** Zeiss Axioscope A1  
**OCULAR MAG:** 2.5x

**OBJECTIVE:** 4x  
**ZOOM:** n/a

**TRINOCULAR MAG:** 1x  
**LIGHT SOURCE:** Halogen

**FILTERS:** Daylight  
**COLOR TEMP:** n / a

**NOTES:** A – Biogenic Marine Sand – Fine Aggregate. Coarse aggregate includes Hydrated lime (not shown).  
 B – Portland cement matrix  
 C – Voids  
 E – Paint Layer



**SAMPLE 4-1**  
**Hand Applied Stucco**  
**THIN SECTION – XPL**

**ORIGIN:** DEL CARMEN CHURCH  
**ANALYZED:** Aug 11<sup>th</sup>, 2020

**IMAGING:** Nikon DS-Fi1 camera  
 with NIS Elements BR software

**MICROSCOPE:** Zeiss Axioscope A1  
**OCULAR MAG:** 2.5x

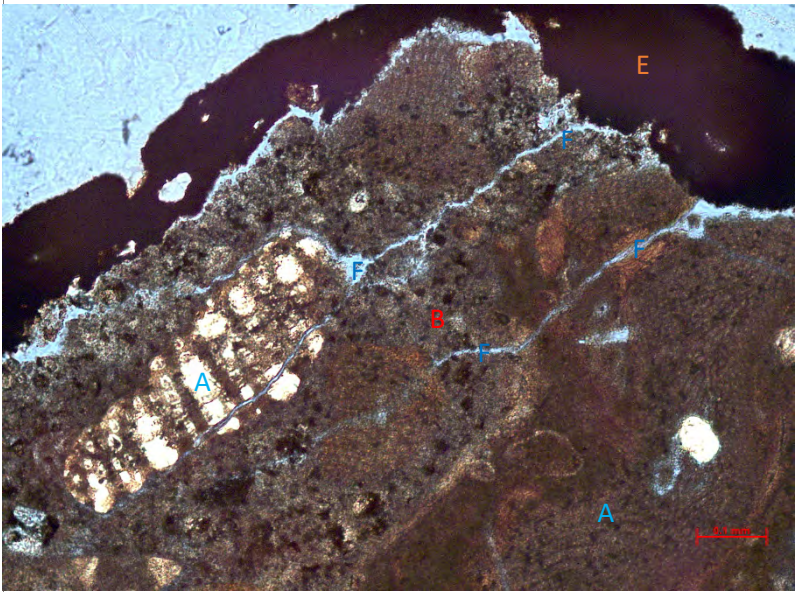
**OBJECTIVE:** 4x  
**ZOOM:** n/a

**TRINOCULAR MAG:** 1x  
**LIGHT SOURCE:** Halogen


**FILTERS:** Daylight  
**COLOR TEMP:** n / a

**NOTES:** Porosity and good compaction of Sample 4-1.  
 C – Voids



	<b>SAMPLE 4-1</b> <b>Hand Applied Stucco</b> <b>THIN SECTION – PPL</b>
	<b>ORIGIN: DEL CARMEN CHURCH</b> <b>ANALYZED: Aug 11<sup>th</sup>, 2020</b>
	<b>IMAGING: Nikon DS-Fi1 camera</b> <b>with NIS Elements BR software</b>
	<b>MICROSCOPE: Zeiss Axioscope A1</b> <b>OCULAR MAG: 10x</b>
	<b>OBJECTIVE: 4x</b> <b>ZOOM: n/a</b>
	<b>TRINOCULAR MAG: 1x</b> <b>LIGHT SOURCE: Halogen</b>
<b>FILTERS: Daylight</b> <b>COLOR TEMP: n / a</b>	

**NOTES:** A – Biogenic Marine Sand – Fine Aggregate. Coarse aggregate includes Hydrated lime (not shown).  
 B – Portland cement matrix  
 E – Paint Layer  
 F – Microcracks product from Sulfate attack, which is usually seen with an extensive system of fine cracks.

	<b>SAMPLE 4-1</b> <b>Hand Applied Stucco</b> <b>THIN SECTION – PPL</b>
	<b>ORIGIN: DEL CARMEN CHURCH</b> <b>ANALYZED: Aug 11<sup>th</sup>, 2020</b>
	<b>IMAGING: Nikon DS-Fi1 camera</b> <b>with NIS Elements BR software</b>
	<b>MICROSCOPE: Zeiss Axioscope A1</b> <b>OCULAR MAG: 10x</b>
	<b>OBJECTIVE: 4x</b> <b>ZOOM: n/a</b>
	<b>TRINOCULAR MAG: 1x</b> <b>LIGHT SOURCE: Halogen</b>
<b>FILTERS: Daylight</b> <b>COLOR TEMP: n / a</b>	

**NOTES:** Ettringite formation in voids on Sample 4-1  
 C – Void  
 D – Ettringite/Salts

## SAMPLE 5

### 1. Visual examination of hand specimens

#### A. Fine aggregates

- i. Natural sand
- ii. Homogeneous – Small and big voids seen along homogeneous small sand grains
- iii. **Surface texture:** Top side – smooth and uniform surface; Bottom (back side) – both smooth and uniform, and rough and irregular; one side rough and uniform; two sides, smooth and uniform
- iv. **Distribution:** Well graded
- v. **Particle Shape:** Rounded elongate and flaky, Sub rounded elongate and flaky, Sub rounded equant, Sub rounded flaky, Rounded equant, Sub angular irregular

#### B. Matrix

- i. **Color by comparison with National Research Council Rock Color Chart (1963) - 2.5Y 8/1 & 2.5Y 7/1**
- ii. **Color distribution – gradational changes:** No – Even Color
- iii. **Fractures:** No visible fractures around or through aggregates
- iv. **Cracks:** No visible cracks
- v. **Contact of matrix with aggregates:** Uniform and filled
- vi. **Contamination:** On one side – fouling on rough surface
- vii. **Bleeding:** No visible bleeding

#### C. Air

- i. **Grading:** Well graded
- ii. **Shape:** Well rounded equant, Rounded equant, Sub angular elongate, Rounded elongate and flaky, Angular elongate and flaky
- iii. **Color change:** Yes. Interior is seen with a dark grey and exterior matrix with lighter grey.
- iv. **Interior surface of Matrix:** Dull
- v. **Linings of voids:** Partial
- vi. **Underside voids or sheets of voids:** Small

#### D. Embedded items

- i. No embedded items

#### E. Relative Hardness - Moh's scale

- i. Between 4.0 and 5.0 – 4.5

### 2. Matrix / Binder

#### A. Type of cement: Pure – Normal Portland Cement

#### B. Nature of relic cement grains -

- i. Size – Small (< 20  $\mu\text{m}$ ), few medium-sized (20-60  $\mu\text{m}$ )
- ii. Distribution – Moderately sorted

- iii. Shape – Sub-rounded irregular, Rounded equant, Sub rounded equant

### **C. Examination of Unhydrated / Partially Hydrated clinker**

- i. Belite – Dicalcium Silicate is present
- ii. Ferrite – Tetracalcium aluminoferrite was preliminary confirmed

## **3. Microstructure**

### **A. Air Voids**

- i. A majority of entrapped air voids (irregularly shaped air voids - < 1 mm) were seen compared to few entrained air voids (spherical shaped air voids – between 10 µm to 1 mm) were seen.
- ii. **Proportion of spherical and nonspherical:**
  - Spherical – 7%
  - Nonspherical – 20%
- iii. Approx. Width – Between 1.57 mm and 0.08 mm
- iv. Visual estimation and compaction description based from Ingham (2012): >3.0 – 5.0% – Medium compaction

### **B. Water/Cement Ratio – W/C**

- i. Apparent microporosity – Between normal 0.35-0.65 (Normal) and > 0.65 (High W/C)

### **C. Cracks** – usually described manually which must include the following features:

- i. Cracks occur in matrix
- ii. Details of the adjacent cement matrix – Microcracks on matrix and around aggregates
- iii. Length – Not assessed
- iv. Presence/density of cracking infillings
  - Widths - Fine microcracks: <1 µm - A few millimeters
  - Plastic shrinkage cracks - appear as a linear series of tension gashes that run through the cement matrix and around aggregate particles
  - Some cracks are seen on the edges of the sample, possibly because of the sample preparation and cutting

## **4. Aggregates**

### **A. Coarse Aggregates**

- i. Types of grading: Poorly sorted
- ii. Particle shape – Rounded equant
- iii. Color – Dark brown, brown
- iv. Nominal Max. Size – 2.07 mm
- v. Internal structure – pores (hydrated lime)
- vi. Paste-aggregate bond – good bonding, no voids or cracks seen
- vii. Mineral composition – dolomitic hydrated lime (pure calcium oxide)

## **B. Fine Aggregates**

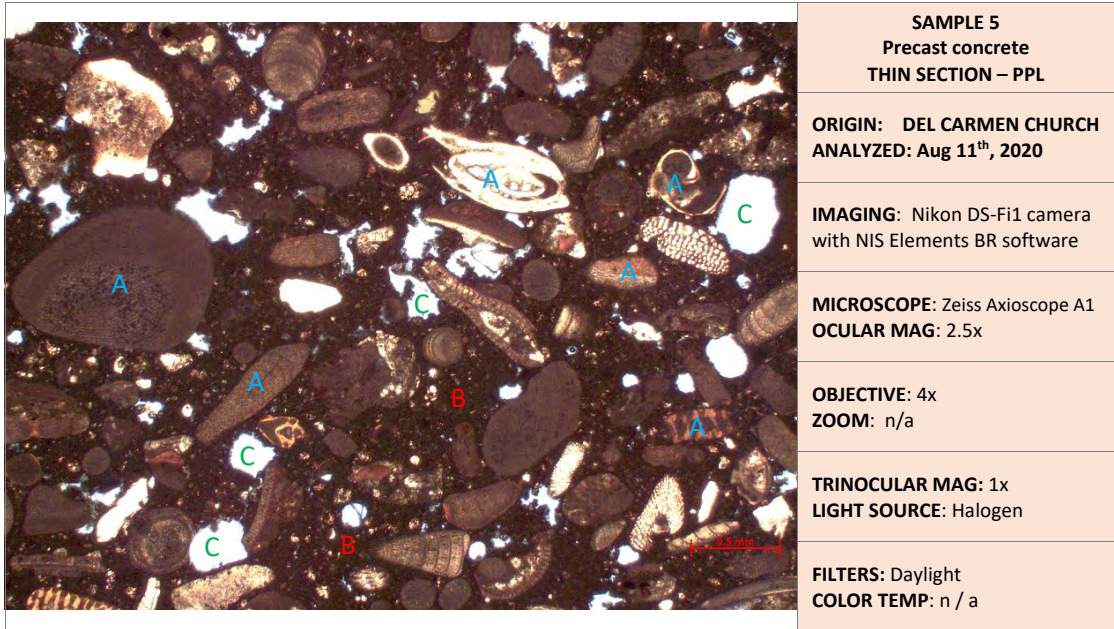
- i. Type of grading: Poorly sorted
- ii. Particle shape – Rounded elongate, Rounded elongate and flaky, Rounded, Sub rounded flaky, Well rounded equant, Sub rounded elongate
- iii. Color – Brown, yellowish-brown, cream, reddish-brown
- iv. Nominal Max. Size – between 2.31 mm and 0.14 mm
- viii. Paste-aggregate bond - peripheral voids
- ix. Internal structure – Voids on some shells
- x. Mineral composition – Organic shells – calcite and probably aragonite, quartz, feldspars and other crushed stones

## **5. Additions and Admixtures**

- a. Admixtures – None
- b. Additives – None
- c. Mineral additions – None

## **A. Other considerations**

- A. Number of layers and layer thickness:
  - Not Assessed



**SAMPLE 5**  
**Precast concrete**  
**THIN SECTION – PPL**

**ORIGIN:** DEL CARMEN CHURCH  
**ANALYZED:** Aug 11<sup>th</sup>, 2020

**IMAGING:** Nikon DS-Fi1 camera  
 with NIS Elements BR software

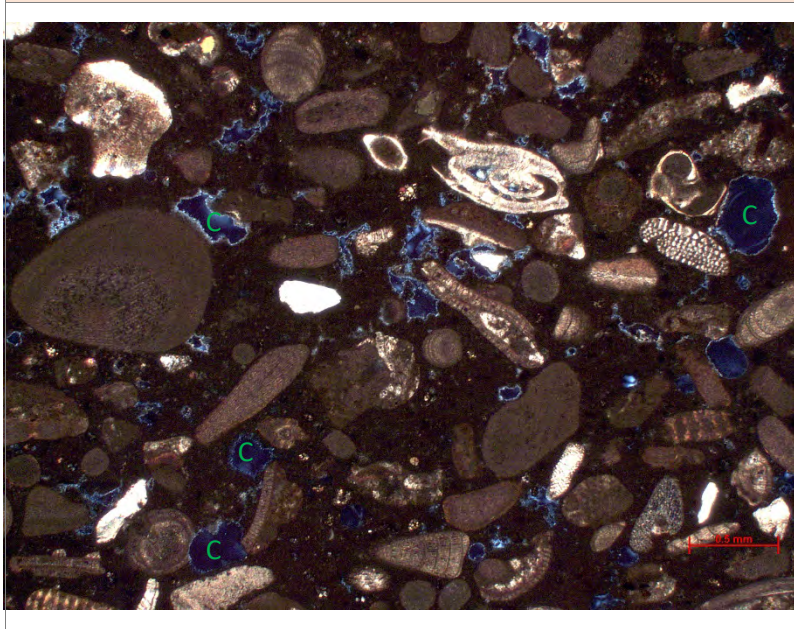
**MICROSCOPE:** Zeiss Axioscope A1  
**OCULAR MAG:** 2.5x

**OBJECTIVE:** 4x  
**ZOOM:** n/a

**TRINOCULAR MAG:** 1x  
**LIGHT SOURCE:** Halogen

**FILTERS:** Daylight  
**COLOR TEMP:** n / a

**NOTES:** A – Biogenic Marine Sand – Fine Aggregate. Coarse aggregate includes Hydrated lime (not shown).  
 B – Portland cement matrix  
 C – Voids



**SAMPLE 5**  
**Precast concrete**  
**THIN SECTION – XPL**

**ORIGIN:** DEL CARMEN CHURCH  
**ANALYZED:** Aug 11<sup>th</sup>, 2020

**IMAGING:** Nikon DS-Fi1 camera  
 with NIS Elements BR software

**MICROSCOPE:** Zeiss Axioscope A1  
**OCULAR MAG:** 2.5x

**OBJECTIVE:** 4x  
**ZOOM:** n/a

**TRINOCULAR MAG:** 1x  
**LIGHT SOURCE:** Halogen

**FILTERS:** Daylight  
**COLOR TEMP:** n / a

**NOTES:** Porosity and medium compaction of Sample 5.  
 C – Voids

	<p><b>SAMPLE 5</b>  <b>Precast concrete</b>  <b>THIN SECTION – XPL</b></p>
	<p><b>ORIGIN:</b> DEL CARMEN CHURCH  <b>ANALYZED:</b> Aug 11<sup>th</sup>, 2020</p>
	<p><b>IMAGING:</b> Nikon DS-Fi1 camera  with NIS Elements BR software</p>
	<p><b>MICROSCOPE:</b> Zeiss Axioscope A1  <b>OCULAR MAG:</b> 20x</p>
	<p><b>OBJECTIVE:</b> 4x  <b>ZOOM:</b> n/a</p>
<p><b>TRINOCULAR MAG:</b> 1x  <b>LIGHT SOURCE:</b> Halogen</p>	
<p><b>FILTERS:</b> Daylight  <b>COLOR TEMP:</b> n / a</p>	

**NOTES:** Sulfate attack on Sample 5  
C – Void  
D – Salts – Sulfate attack

	<p><b>SAMPLE 5</b>  <b>Precast concrete</b>  <b>THIN SECTION – PPL</b></p>
	<p><b>ORIGIN:</b> DEL CARMEN CHURCH  <b>ANALYZED:</b> Aug 11<sup>th</sup>, 2020</p>
	<p><b>IMAGING:</b> Nikon DS-Fi1 camera  with NIS Elements BR software</p>
	<p><b>MICROSCOPE:</b> Zeiss Axioscope A1  <b>OCULAR MAG:</b> 2.5x</p>
	<p><b>OBJECTIVE:</b> 4x  <b>ZOOM:</b> n/a</p>
<p><b>TRINOCULAR MAG:</b> 1x  <b>LIGHT SOURCE:</b> Halogen</p>	
<p><b>FILTERS:</b> Daylight  <b>COLOR TEMP:</b> n / a</p>	

**NOTES:** A – Biogenic Marine Sand – Fine Aggregate. Coarse aggregate includes Hydrated lime (not shown).  
B – Portland cement matrix  
C – Voids  
D – Paint Layer  
E – Microcracks

GRADUATE STUDENT AND POSTDOCTORAL FELLOW  
RESEARCH RESUMPTION REQUEST FORM

The University of Pennsylvania has outlined guidelines for a phased resumption of research activities on campus. See: <https://research.upenn.edu/resources/resumption/>. The purpose of this form is to collect information from graduate students and postdoctoral fellows who would like to volunteer to resume research activity during Phase I of the research resumption plan. During Phase I, population density on campus will be limited and any research that can be done remotely should be continued to be done remotely.

**Graduate student and postdoc participation in research on Penn's campus is entirely voluntary. Researchers have the choice to opt-in to the process but are not in any way compelled to do so.**

This form applies only to research activities to be conducted at the Penn Museum, particularly in laboratories and other limited settings. It does not pertain to research that requires travel or fieldwork, or to any other research activities that depend on the policy decisions of various states, countries and institutions. In the case of laboratory research, graduate students and postdoctoral fellows will be able to return to campus only after their faculty supervisors have received approval from OVPR to resume activities in accordance with the health and safety guidelines outlined by the University.

Again, Phase I research resumption will begin with the fewest people possible in order to maintain low population density, and with continued reliance on remote work whenever possible. Therefore, there will be limits on the number of individuals permitted to return to campus and the amount of time they will be able to spend working there. You may not return to the Penn Museum until your proposal has been reviewed and approved by your supervisor and the Museum's Deputy Director, Steve Tinney (stinney@upenn.edu).

Both the Museum and the School of Arts & Sciences are committed to ensuring that researchers are not pressured or coerced to return to on-campus activities. Students and postdocs with concerns about the School-based procedures can contact [provost-ed@upenn.edu](mailto:provost-ed@upenn.edu) for students or [vpr@upenn.edu](mailto:vpr@upenn.edu) for postdocs.

If you would like to volunteer to return to campus when Phase I research resumption begins, please provide the following information.

Name	Héctor J. Berdecia-Hernández
Department	Graduate Program in Historic Preservation
Email address	berdecia@design.upenn.edu
Phone number	787-616-5325
Faculty Advisor/Supervisor's Name	Frank G. Matero / Marie-Claude Boileau
Faculty Advisor/Supervisor's Email address	<a href="mailto:fgmatero@design.upenn.edu">fgmatero@design.upenn.edu</a> <a href="mailto:mboileau@upenn.edu">mboileau@upenn.edu</a>
For Graduate Students, Year in the Program as of Fall 2020	Graduating – Summer 2020 (September 4 <sup>th</sup> , 2020)

1: Returning to campus in Phase I is voluntary. If you wish to resume any on-campus activities in Phase I, whether laboratory research or office or studio work, please complete the following information.

I am requesting access to (you may provide more than one location):

Study space	
Office	
Laboratory	X

2. Frequency of access

I am requesting:

One-time access to the space	
Several visits to the space	
Ongoing access to the space	X

3. What is the physical location of the space(s) on campus? (Museum room number(s)):

Space #1	Ceramics Laboratory – MUSE 169
Space #2	
Space #3	



4. Is this campus access critical to finishing your degree or your postdoctoral fellowship research by Dec. 31, 2020?

Yes	X
No	

5. Please provide a brief justification of why you need to return to campus. For office or studio access, please explain why you must work on campus and indicate how many others may be sharing the same space. For laboratory research, describe the capabilities in your lab or in core/multi-user that are essential to your academic or career progress during Phase I research resumption. Note that for laboratory research detailed plans submitted by the PI will be reviewed separately, so that your description may be brief.

I applied to Graduate in Spring 2020 in February. Since all laboratories closed from mid-March on, my Department granted a special permission to finish my thesis research over the Summer. I will need to access the Ceramics Laboratory (Room MUSE 169) to work on a Petrographic analysis. This specific analysis is critical for my research, since most of other instrumental analyses scheduled for my research are not possible because of the current situation. During my time at the Lab, I will analyze 12 specific thin sections based on an approved research proposal submitted to Dr. Boileau and Prof. Matero. One selected microscope will be used for this specific research.

I have successfully taken Petrography of Cultural Materials this past Spring semester and am already trained on the polarizing light microscopes in the Ceramics Lab. I completed the EHRS required training for research resumption and have read the laboratory protocols for CAAM. I have also set up the PennOpen Pass system and will use it to enter the museum.

I would like to start Wednesday July 29<sup>th</sup>, 2020 and conduct my analysis over the course of two and a half weeks, aiming to complete petrographic analysis by mid-August or sooner. I will come in according to the lab schedule set up by Dr. Marie-Claude Boileau to ensure that only one person is in the lab at a given time. For next week, we discussed blocks of 4.5 hours, from 11am-3:30pm Wednesday through Friday.

6. Are you already trained on the instrument(s) you need to use in the laboratory?

N/A	
Yes	X
No	

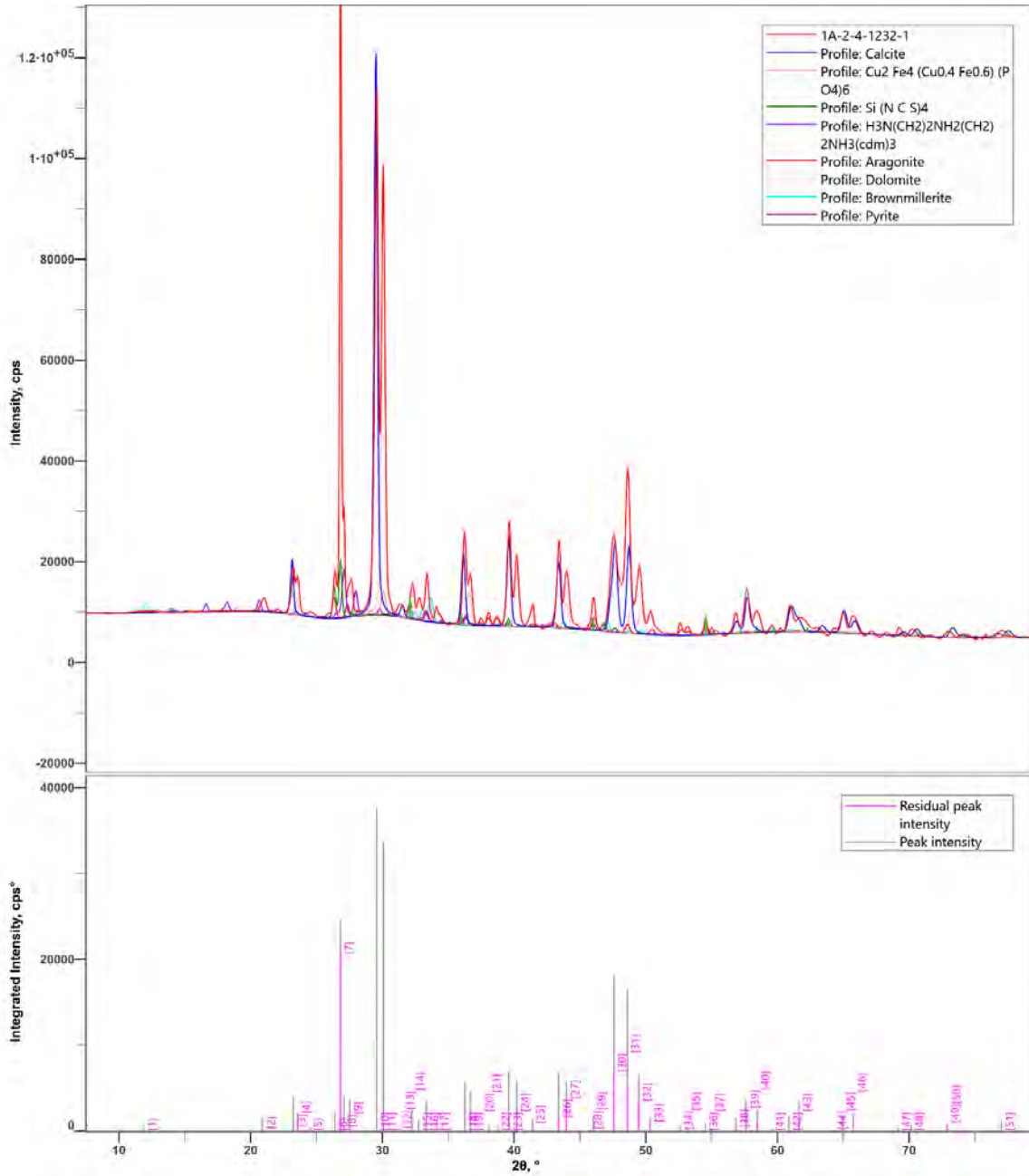
7. If you have any additional questions or concerns, please list them below.

# APPENDIX 14

## X-RAY POWDER DIFFRACTION SPECTROMETRY (XRD)

### SAMPLE 1A-2

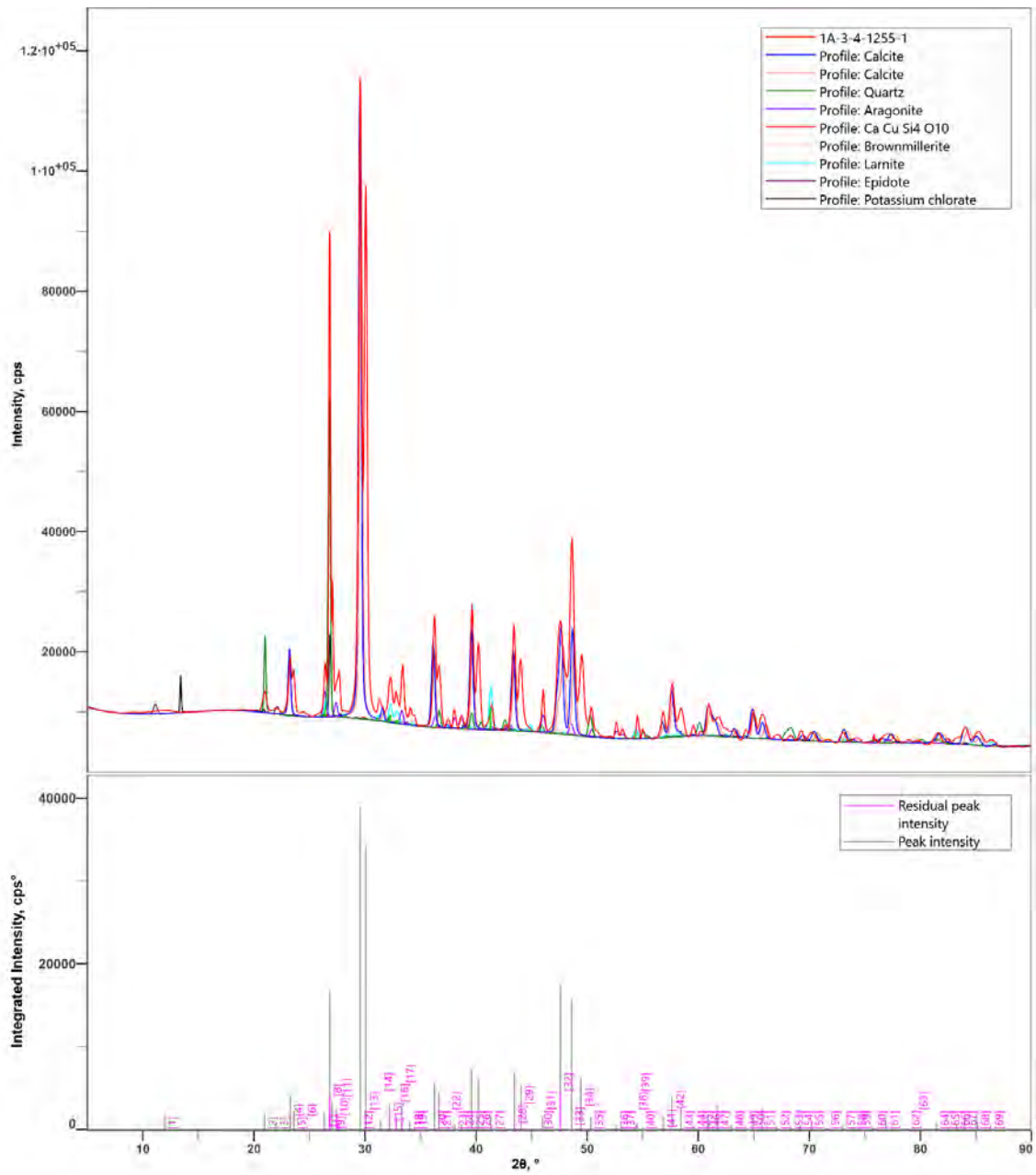
DATE OF ANALYSIS – August 27<sup>th</sup>, 2020



XRD Patterns from analysis of powdered Sample 1A-2 of the Del Carmen Church. Patterns shows a match with Dolomite, Aragonite and Pyrite phases.

# SAMPLE 1A-3

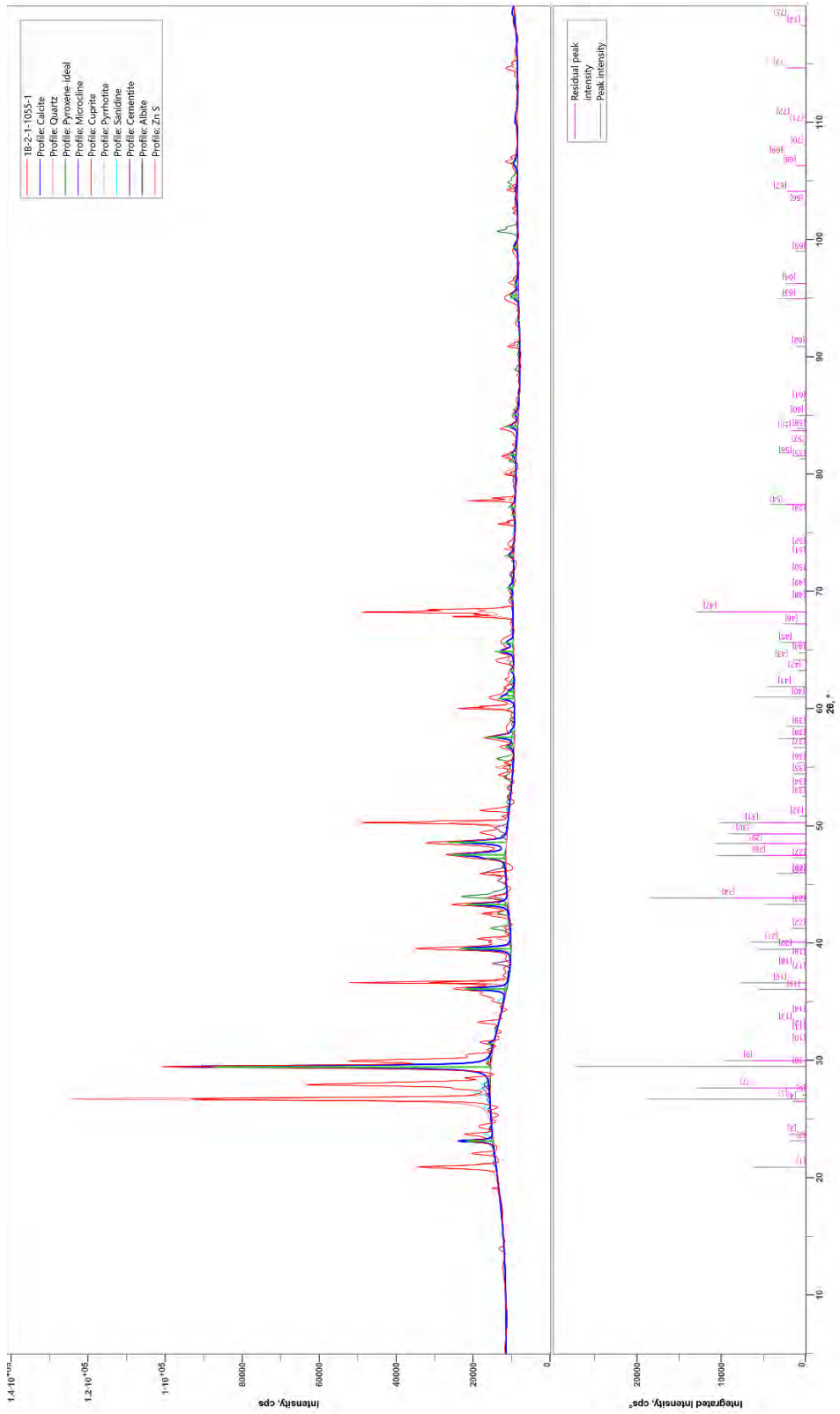
DATE OF ANALYSIS – August 27<sup>th</sup>, 2020



XRD Patterns from analysis of powdered Sample 1A-3 of the Del Carmen Church. Patterns shows a match with Aragonite, Potassium Chlorate, Larnite and Epidote phases.

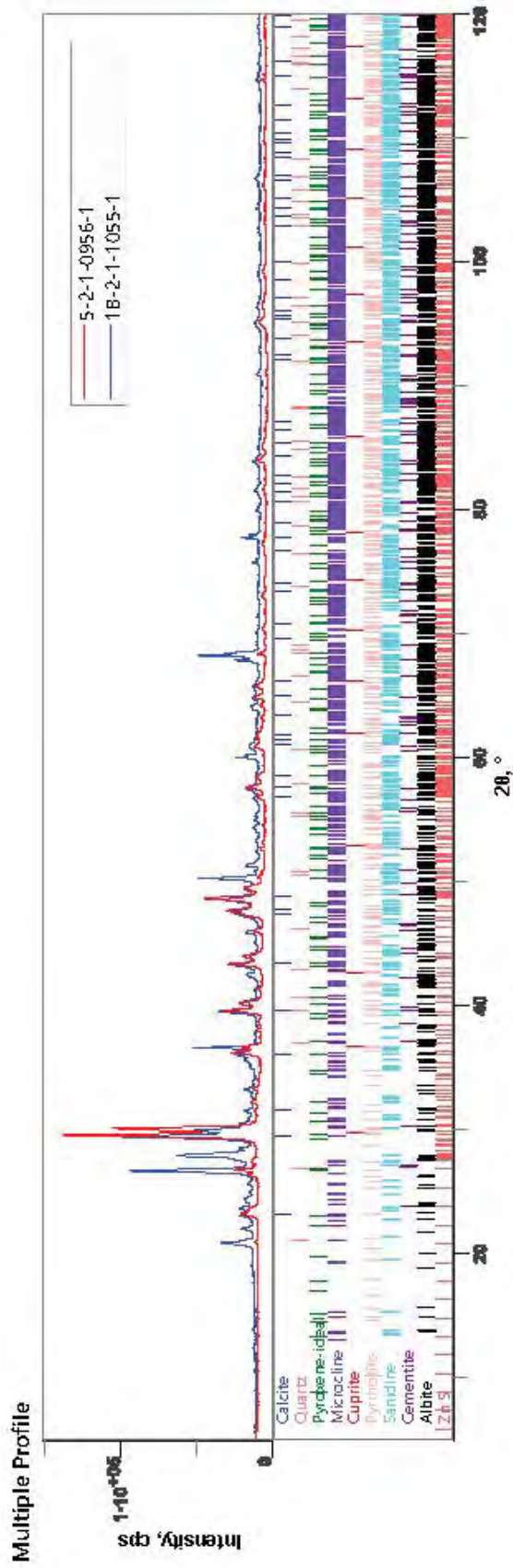
# SAMPLE 1B

DATE OF ANALYSIS – August 31<sup>st</sup>, 2020



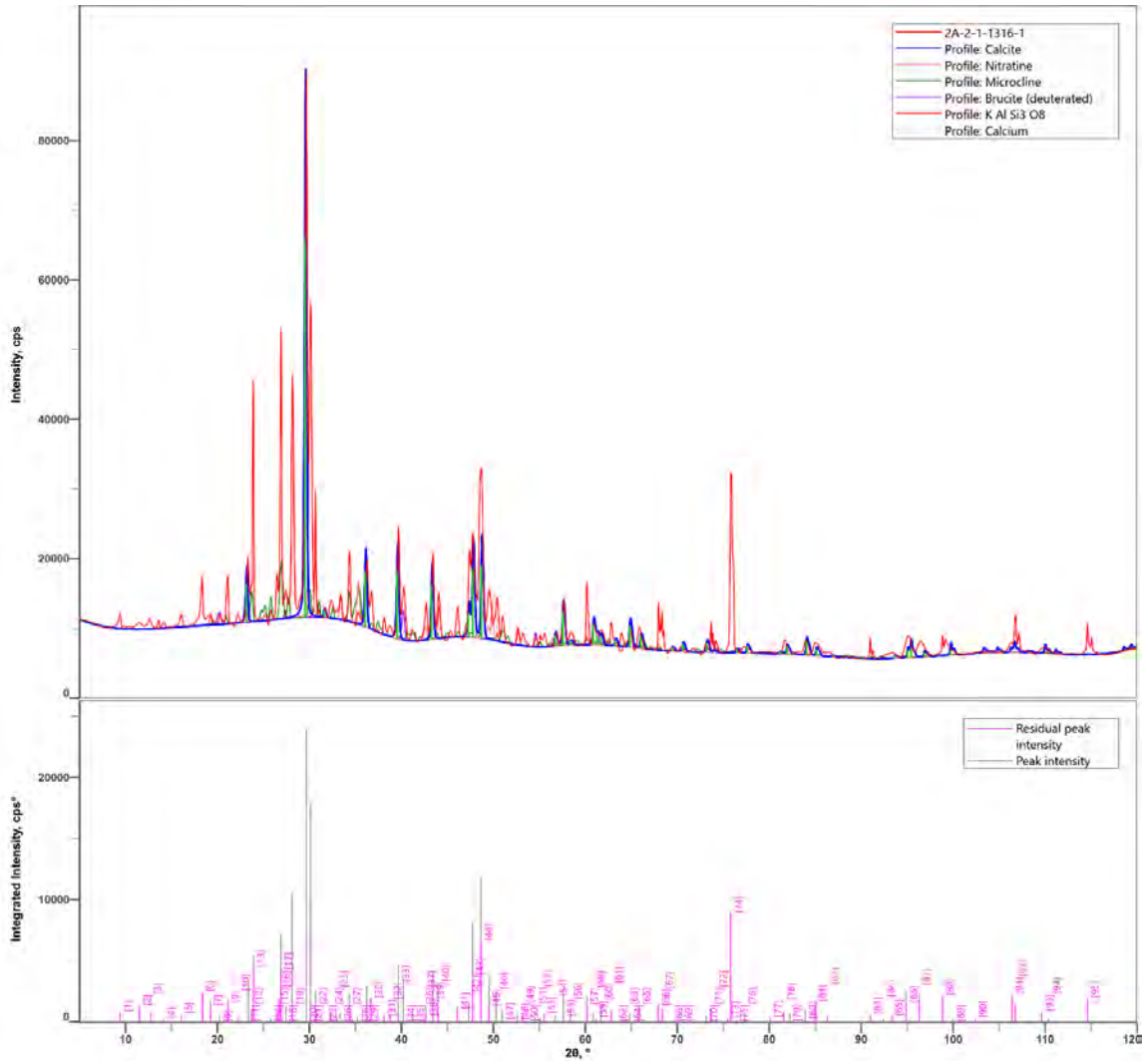
XRD Patterns from analysis of powdered Sample 1B of the Del Carmen Church. Patterns shows a match with Albite, Pyrrhotite, Pyroxene-ideal and Cementite phases.

SAMPLE 1B



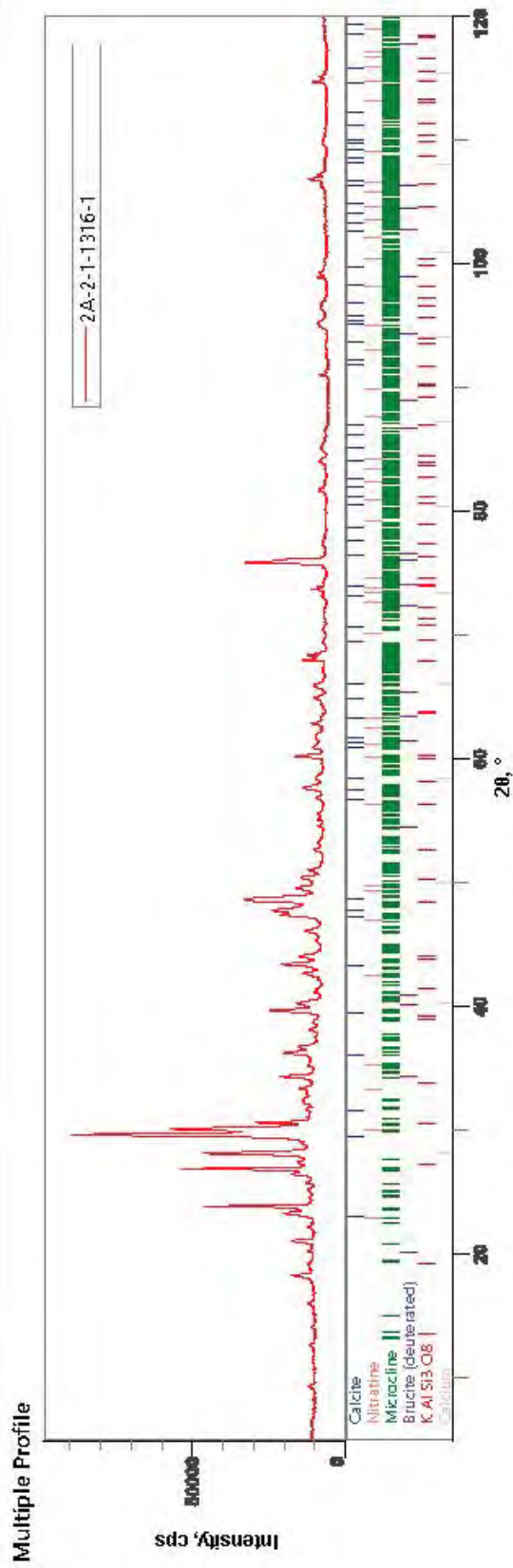
# SAMPLE 2A-1

DATE OF ANALYSIS – August 28<sup>th</sup>, 2020



XRD Patterns from analysis of powdered Sample 2A-1 of the Del Carmen Church. Patterns shows a match with Nitratine, Brucite, Larnite and Microcline phases.

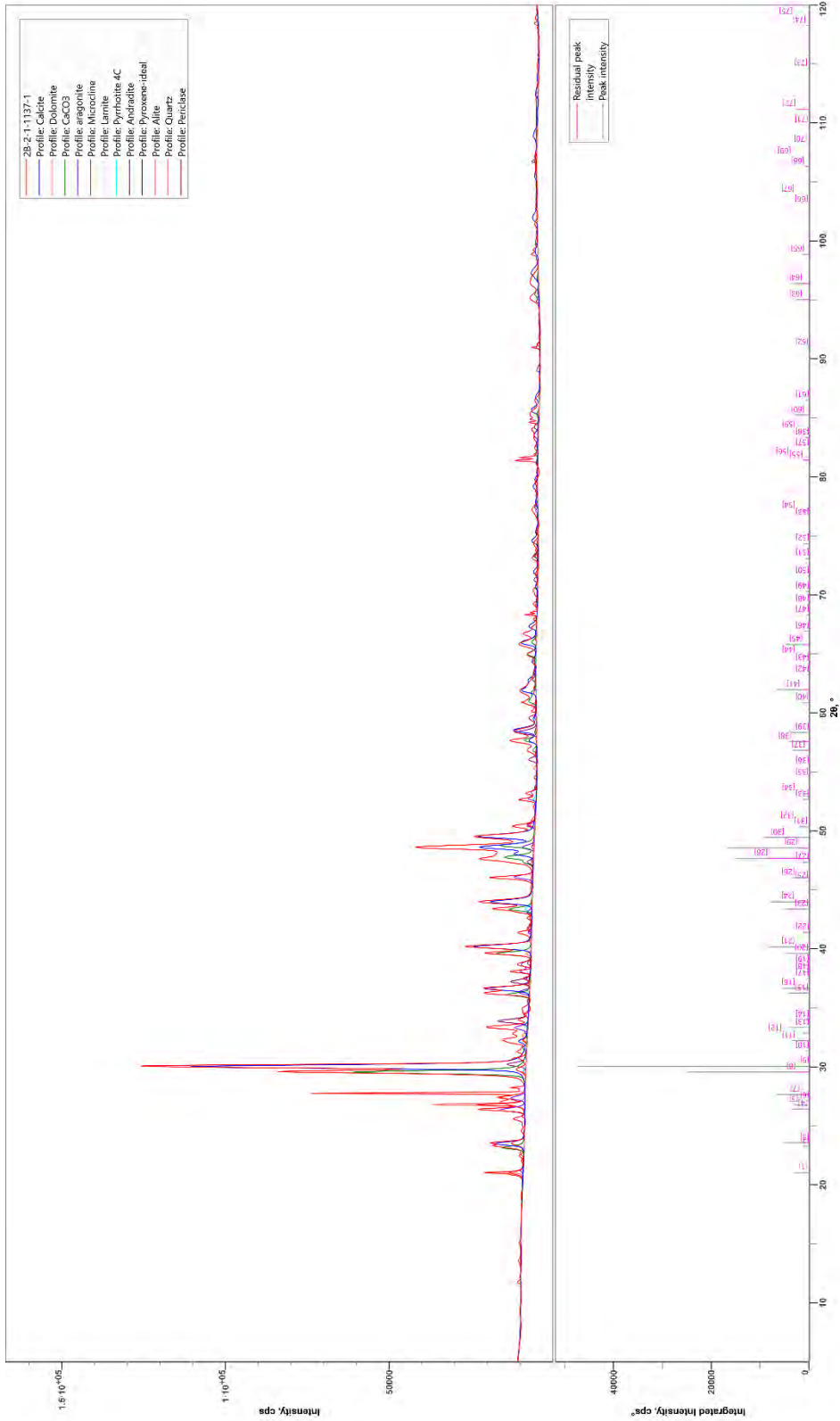
SAMPLE 2A-1





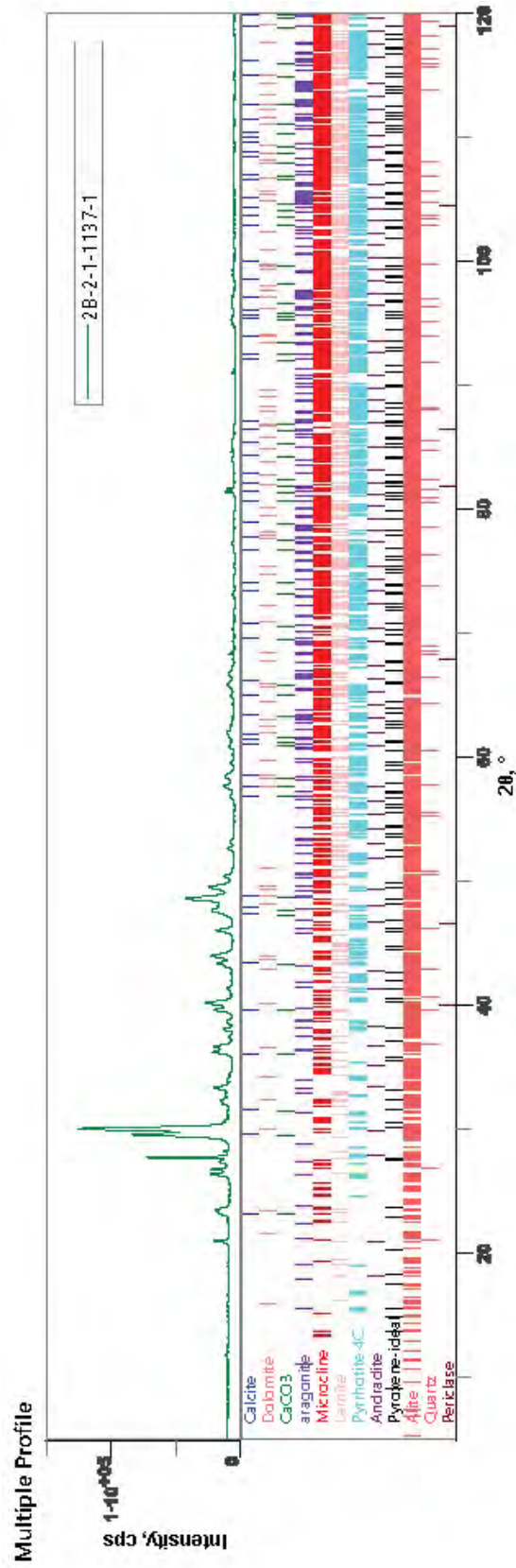
# SAMPLE 2B

DATE OF ANALYSIS - August 31<sup>st</sup>, 2020



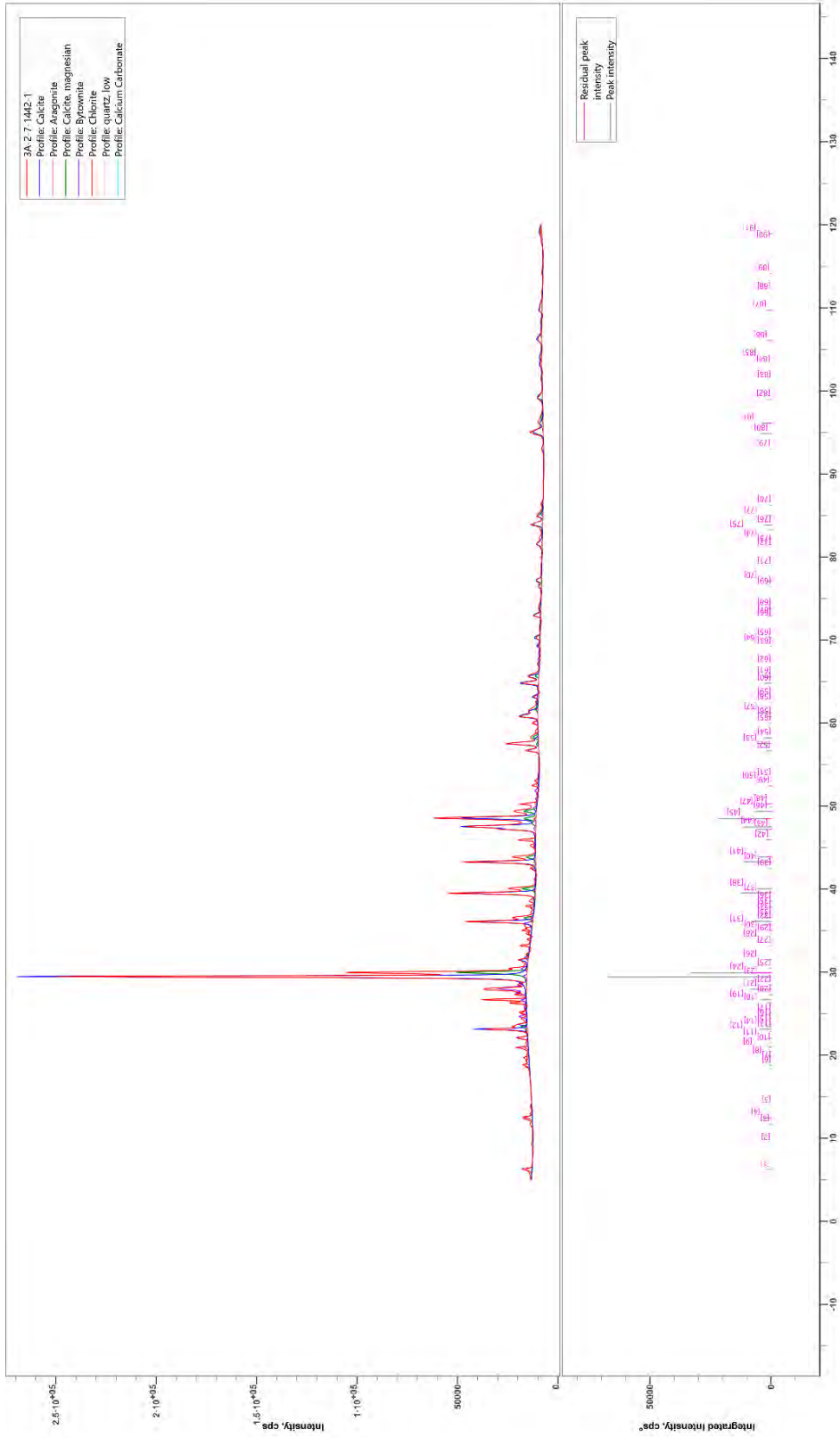
XRD Patterns from analysis of powdered Sample 2B of the Del Carmen Church. Patterns shows a match with Dolomite, Aragonite, Microcline, Pyrrhotite, Larnite, Andradite and Periclase phases.

SAMPLE 2B



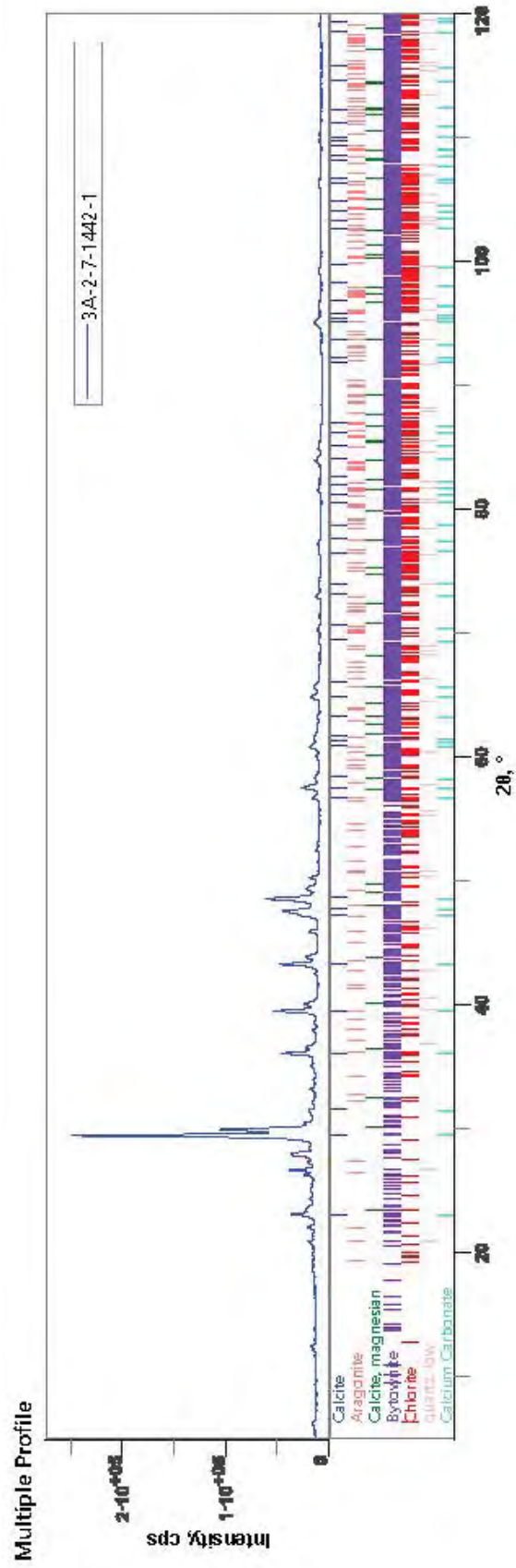
# SAMPLE 3A

DATE OF ANALYSIS – August 28<sup>th</sup>, 2020



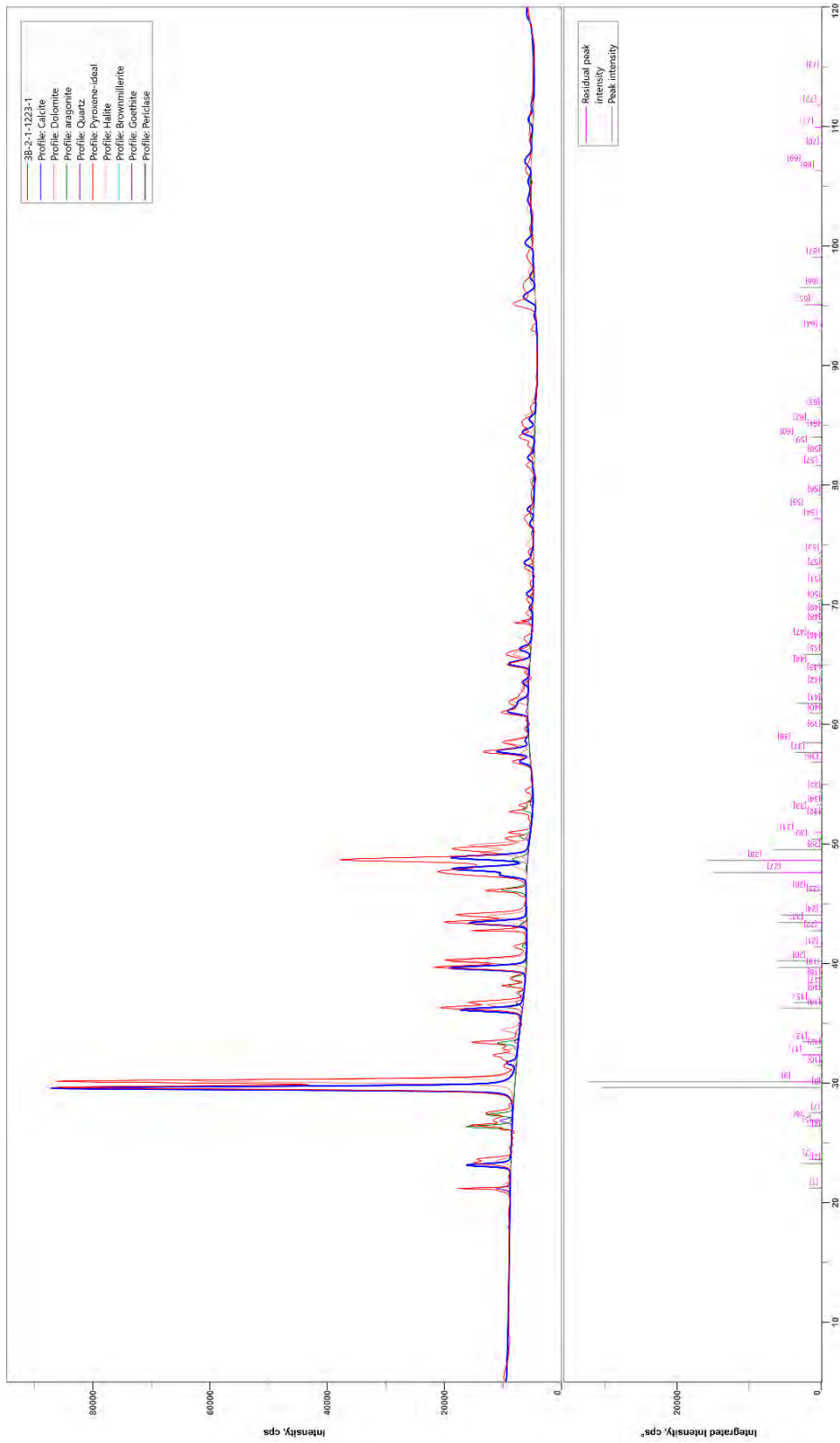
XRD Patterns from analysis of powdered Sample 3A of the Del Carmen Church. Patterns shows a match with Chlorite, Aragonite, Calcite Magnesian and Bytownite phases.

SAMPLE 3A



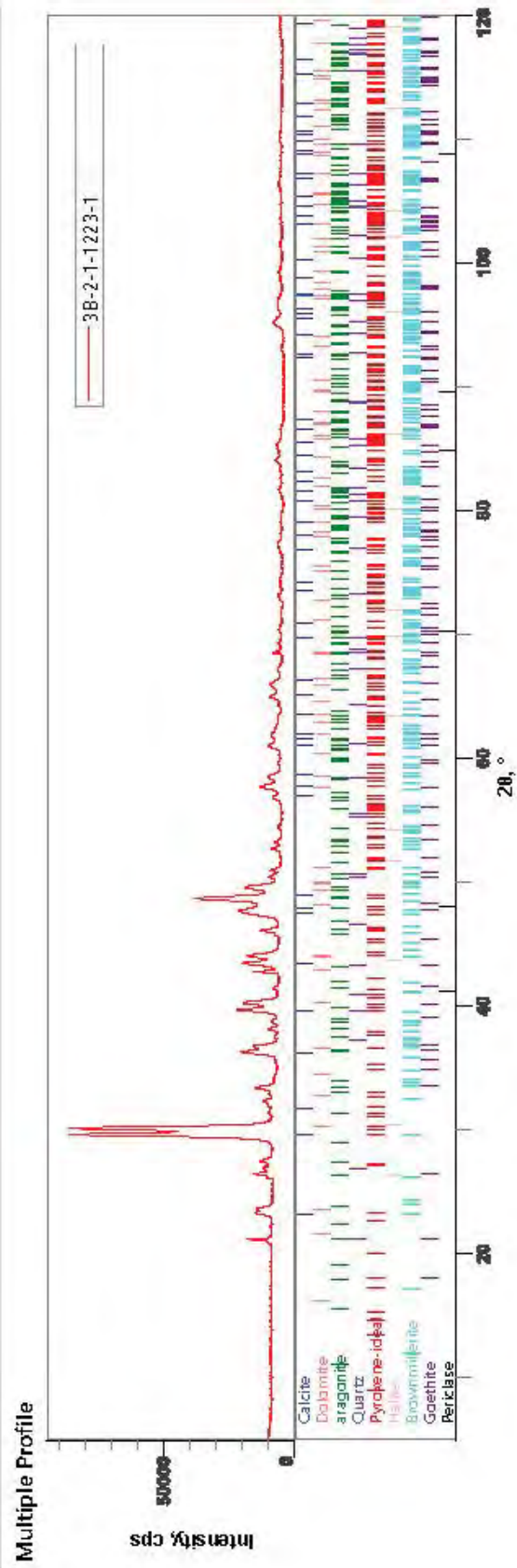
# SAMPLE 3B

DATE OF ANALYSIS - August 31<sup>st</sup>, 2020



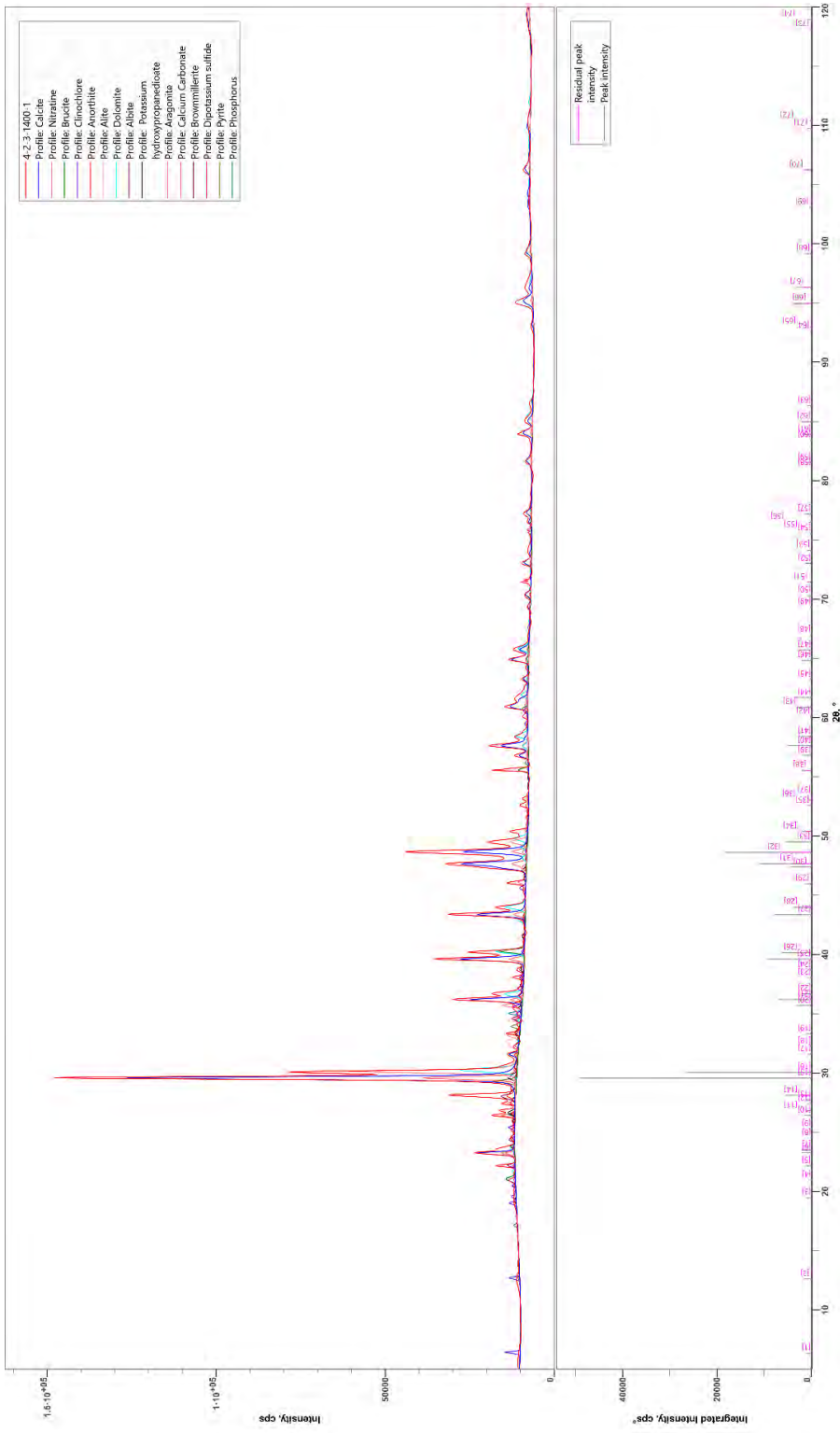
XRD Patterns from analysis of powdered Sample 3B of the Del Carmen Church. Patterns shows a match with Aragonite, Dolomite, Pyroxene-ideal and Periclase phases.

SAMPLE 3B



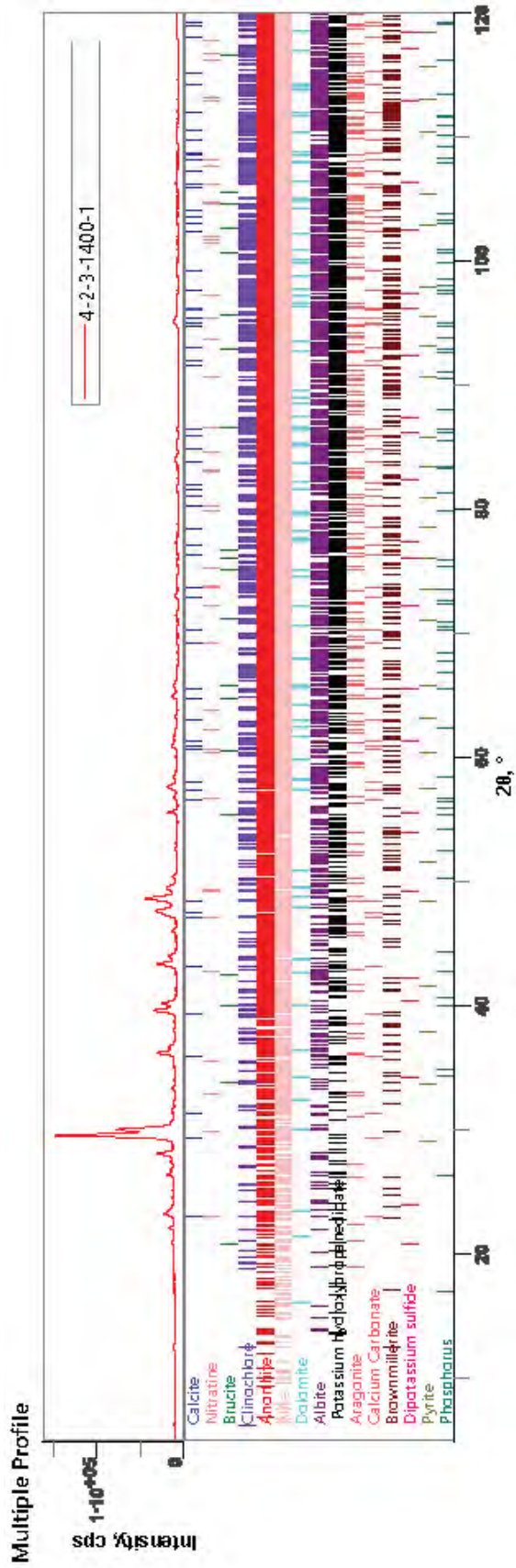
# SAMPLE 4

DATE OF ANALYSIS - August 28<sup>th</sup>, 2020



XRD Patterns from analysis of powdered Sample 4 of the Del Carmen Church. Patterns shows a match with Nitratine, Brucite, Dolomite, Aragonite, Pyrite, Phosphorus and Potassium phases.

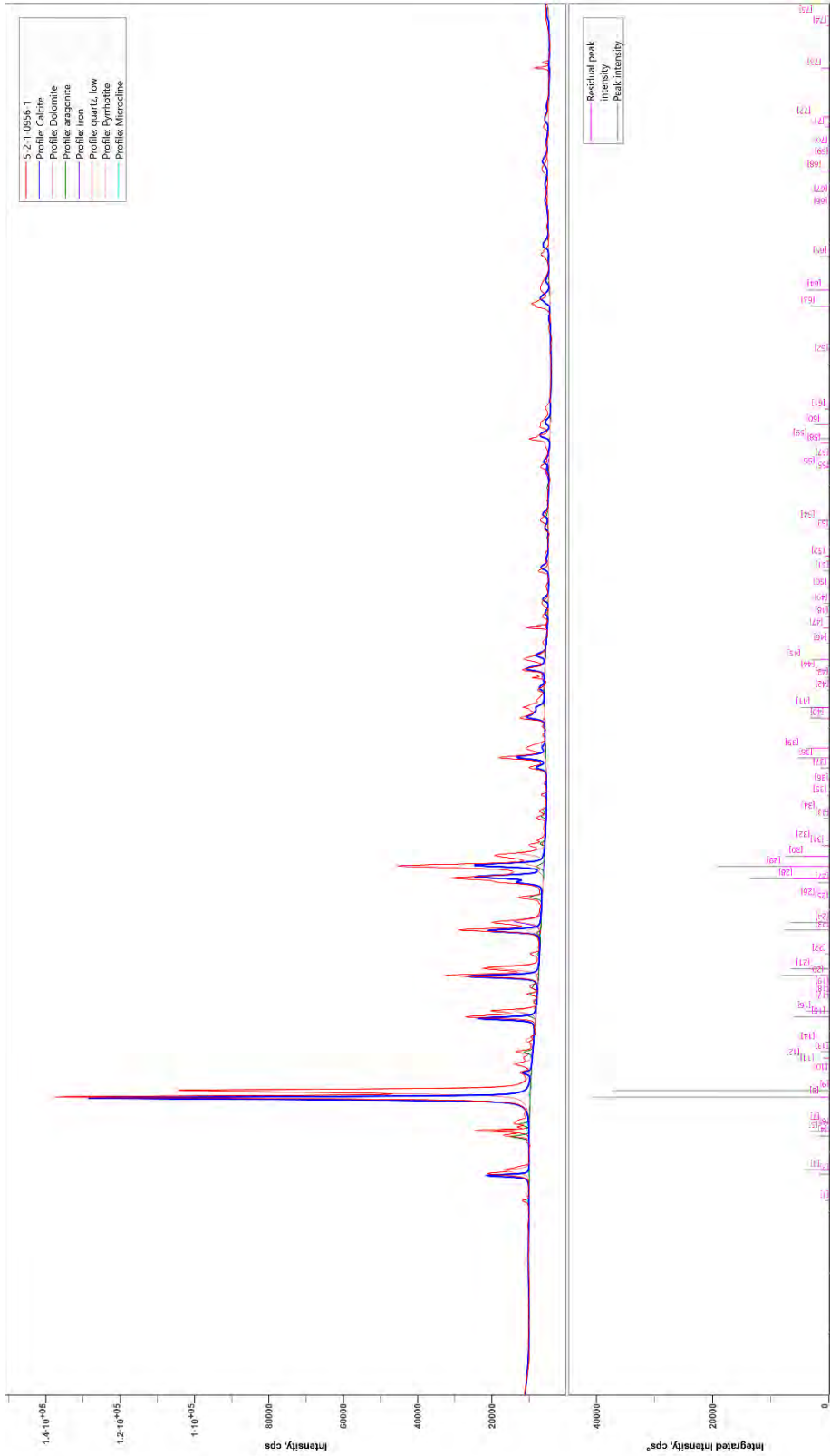
SAMPLE 4





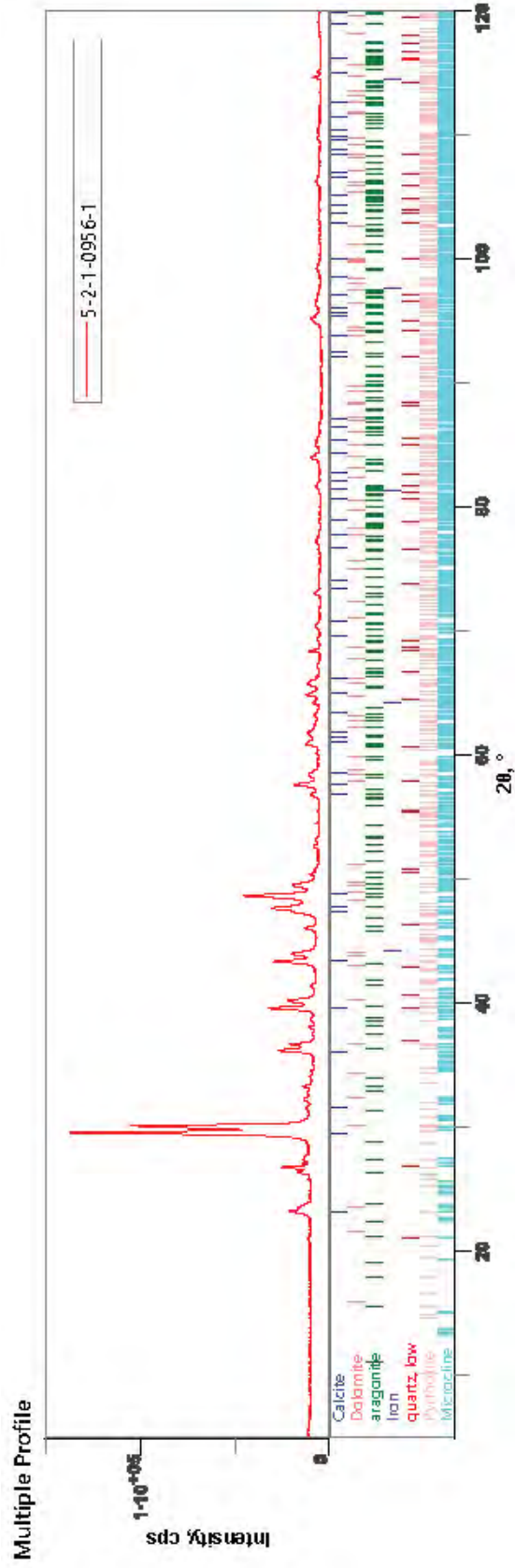
# SAMPLE 5

DATE OF ANALYSIS - August 31<sup>st</sup>, 2020



XRD Patterns from analysis of powdered Sample 5 of the Del Carmen Church. Patterns shows a match with Aragonite, Dolomite, Pyrrhotite, Iron and Microcline phases.

SAMPLE 5



# APPENDIX 15

## SCANNING ELECTRON MICROSCOPY ENERGY DISPERSIVE X-RAY SPECTROSCOPY (SEM-EDS)

### SAMPLE 2A-1

DATE OF ANALYSIS – August 8<sup>th</sup>, 2020  
ANALYZED BY: J. FORD & H. Berdecía-Hernández

#### EDAX TEAM

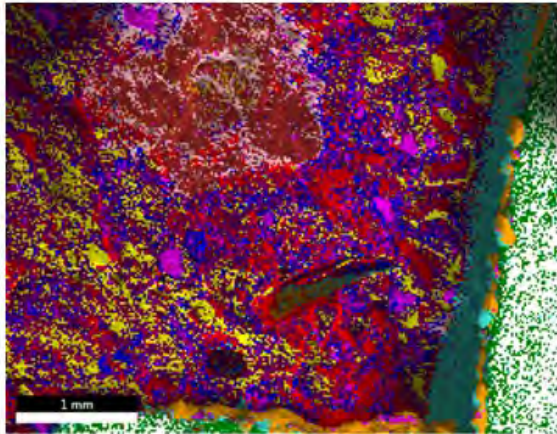
Page 1

### Hector

Author: prnuser  
Creation: 08/08/2020 1:56:46 PM  
Sample Name: 2A-1

#### Area 2

### PhaseROI 2



7%	O K/Ca/Si	K/Ca/Ni/Sr/Zn	(2103 Pixels)
4%	Ca/Ni/Zn/Li	K/C	(2173 Pixels)
15%	O K/Ca/C	K/Sr	(7844 Pixels)
5%	Unallocated		(2677 Pixels)
5%	O K/Sr/Ca/K	Al	(2618 Pixels)
5%	O K/H/Ca/Sr/C	K	(2880 Pixels)
8%	O K/H/Sr/Ca/K		(3385 Pixels)
10%	O K/Ca/Sr/C	K	(5215 Pixels)
4%	C K/O	K/Ca/Sr	(2015 Pixels)
12%	Ca/Sr	K/Sr/C	(5318 Pixels)
25%	Ca/O	K/C/Sr	(12258 Pixels)



Notes:



Image

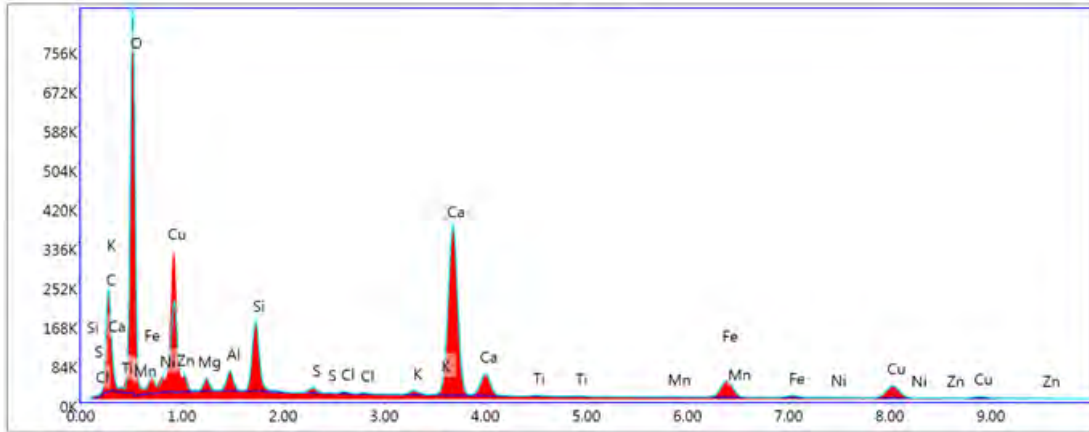
# SUM SPECTRUM

DAX TEAM

Page 8

15 Mag:60 Takeoff:39.3 Live Time(s): 2201.6 Amp Time(μs): 3.84 Resolution:(eV) 128.4

Sum Spectrum



Lsec: 2201.6 16.074K Cnts 2.620 keV Det: Octane Super A

eZAF Smart Quant Results

Element	Weight %	Atomic %	Net Int.	Error %	Kratio	Z	A	F
C K	9.61	18.35	766.50	7.98	0.0366	1.1504	0.3306	1.0000
O K	38.16	54.67	4586.70	8.61	0.1116	1.0984	0.2662	1.0000
NiL	2.29	0.89	171.40	6.53	0.0112	0.8566	0.5717	1.0000
ZnL	2.12	0.74	171.80	6.56	0.0096	0.8162	0.5571	0.9993
MgK	0.74	0.70	175.80	6.92	0.0038	1.0110	0.5095	1.0013
AlK	1.07	0.91	301.10	5.27	0.0067	0.9729	0.6435	1.0024
SiK	3.59	2.93	1151.50	3.94	0.0269	0.9935	0.7499	1.0036
S K	0.34	0.24	91.40	3.65	0.0029	0.9717	0.8787	1.0097
ClK	0.16	0.10	38.70	4.04	0.0014	0.9237	0.9212	1.0154
K K	0.45	0.26	90.20	3.28	0.0042	0.9180	0.9715	1.0343
CaK	23.11	13.21	3790.20	1.87	0.2151	0.9340	0.9839	1.0126
TiK	0.15	0.07	19.80	6.87	0.0013	0.8451	0.9606	1.0284
MnK	0.12	0.05	10.20	15.21	0.0011	0.8153	0.9883	1.0661
FeK	6.88	2.82	476.60	2.79	0.0601	0.8263	0.9930	1.0636
CuK	11.20	4.04	381.90	3.31	0.0911	0.7843	0.9968	1.0398

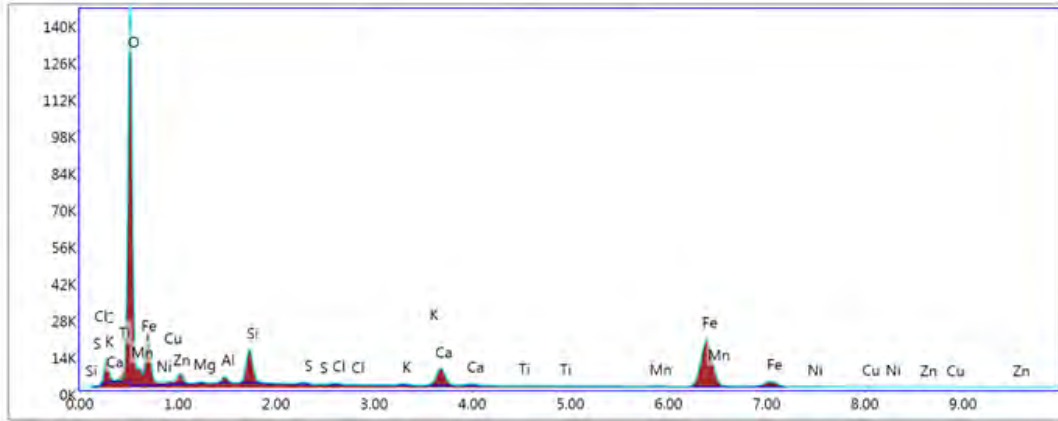
# IRON (Fe) PHASE – O/Fe/Si/Ca

EDAX TEAM

Page 15

kV: 15      Mag: 60      Takeoff: 39.3      Live Time(s): 166.2      Amp Time(μs): 3.84      Resolution(eV) 128.4

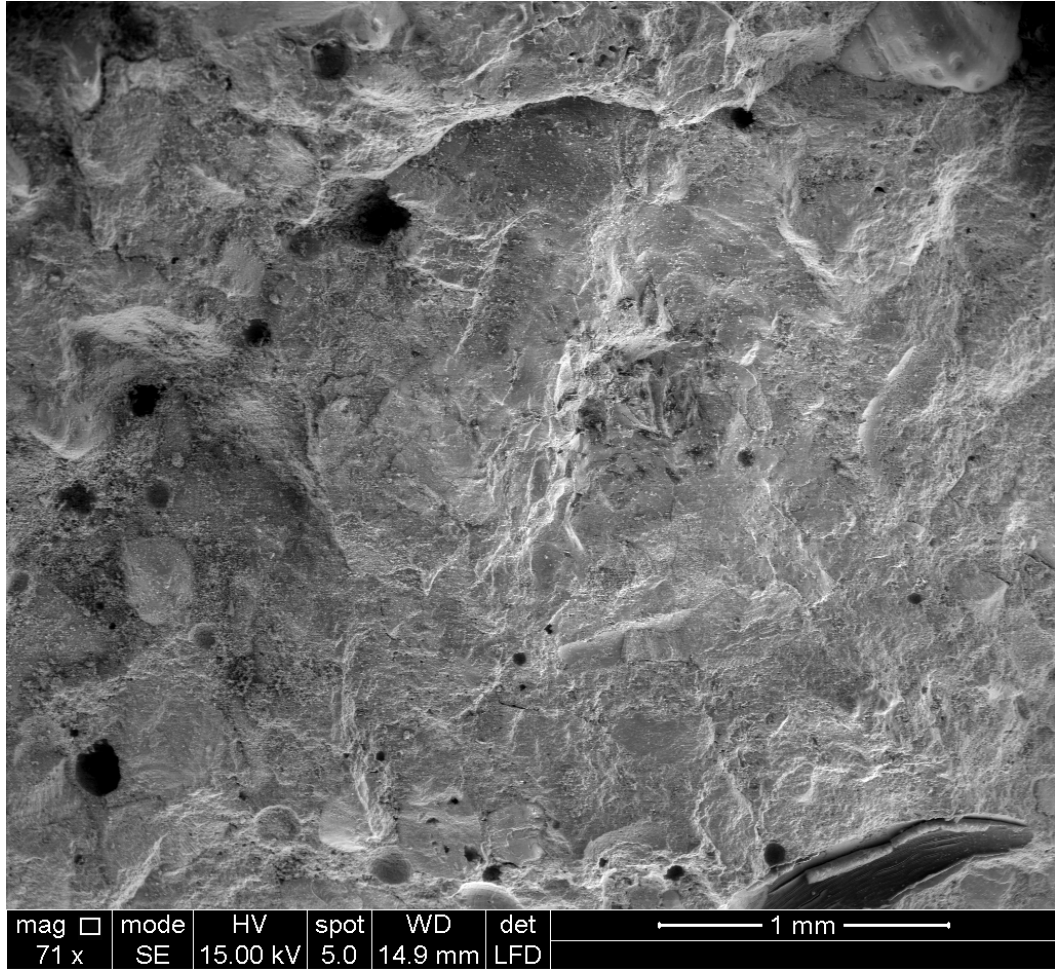
Phase: O K/Fe/Si/CaK



Lsec: 166.2      1.824K Cnts      2.620 keV      Det: Octane Super A

### eZAF Smart Quant Results

Element	Weight %	Atomic %	Net Int.	Error %	Kratio	Z	A	F
C K	5.27	10.57	414.80	8.83	0.0175	1.1708	0.2841	1.0000
O K	42.45	63.93	10873.10	6.53	0.2272	1.1182	0.4786	1.0000
NiL	0.85	0.35	48.70	26.34	0.0028	0.8724	0.3756	1.0000
ZnL	1.97	0.73	155.90	12.04	0.0076	0.8313	0.4625	0.9992
MgK	0.26	0.25	64.20	12.88	0.0012	1.0299	0.4421	1.0011
AlK	0.82	0.74	255.50	7.10	0.0048	0.9911	0.5814	1.0020
SiK	3.74	3.21	1362.20	4.81	0.0265	1.0123	0.6991	1.0029
S K	0.25	0.19	78.40	13.40	0.0021	0.9903	0.8483	1.0080
ClK	0.23	0.15	65.40	10.38	0.0019	0.9415	0.8992	1.0126
K K	0.32	0.20	77.50	10.69	0.0030	0.9358	0.9603	1.0277
CaK	4.54	2.73	924.00	2.65	0.0435	0.9523	0.9764	1.0302
TiK	0.05	0.02	8.20	58.13	0.0004	0.8618	0.9869	1.0647
MnK	0.24	0.10	25.10	20.75	0.0022	0.8318	1.0014	1.1111
FeK	38.78	16.73	3190.60	2.53	0.3326	0.8432	1.0032	1.0141
CuK	0.24	0.09	9.90	54.21	0.0020	0.8009	0.9847	1.0298



# SAMPLE 2A-1

DATE OF ANALYSIS – September 8<sup>th</sup>, 2020  
ANALYZED BY: J. FORD & H. Berdecía-Hernández

## EDAX TEAM

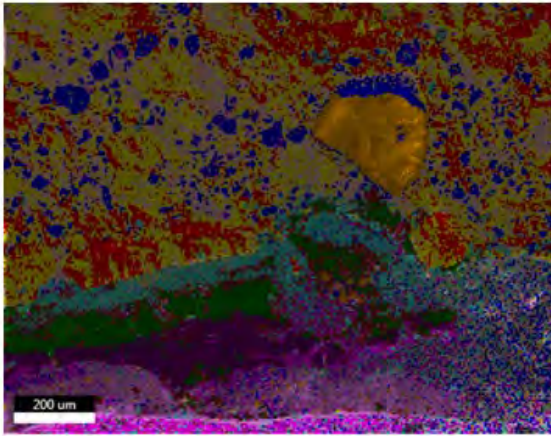
Page 1

tjford

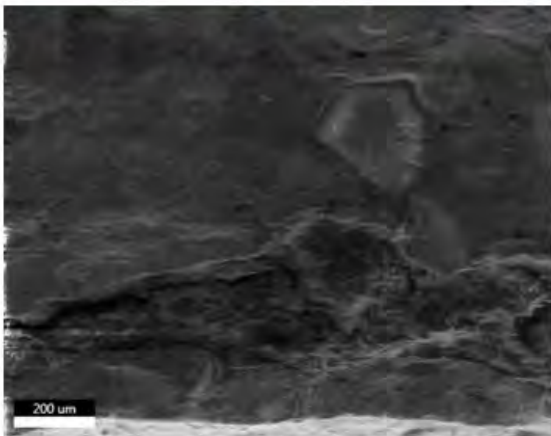
Author: pruser  
Creation: 09/09/2020 3:31:20 PM  
Sample Name: Hector 2A-1 DCC

## Area 2

### PhaseROI 2



Notes:



Image

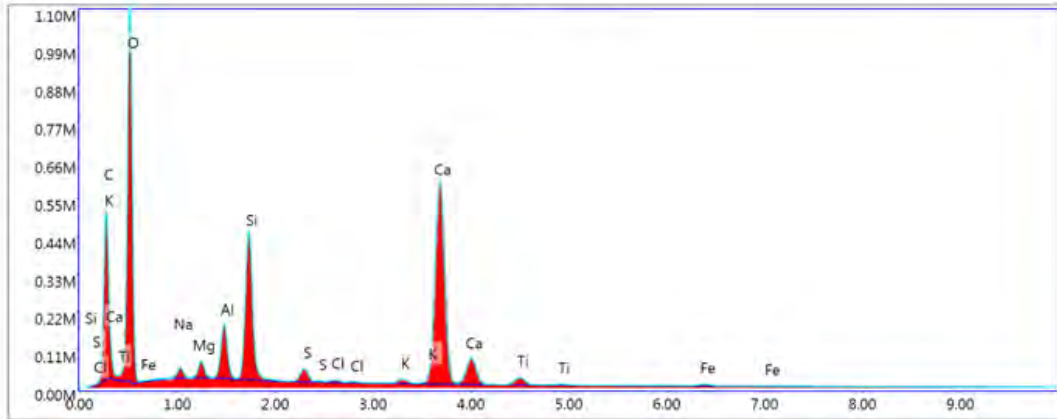
# SUM SPECTRUM

EDAX TEAM

Page 7

kV: 15      Mag: 200      Takeoff: 44.9      Live Time(s): 2846.7      Amp Time(μs): 3.84      Resolution:(eV) 128.8

Sum Spectrum



Lsec: 2846.7      22.215K Cnts      0.850 keV      Det: Octane Super A

eZAF Smart Quant Results

Element	Weight %	Atomic %	Net Int.	Error %	Kratio	Z	A	F
C K	15.30	25.11	746.20	7.58	0.0624	1.1033	0.3697	1.0000
O K	41.56	51.20	2324.80	8.93	0.1025	1.0520	0.2345	1.0000
NaK	0.72	0.62	73.70	6.92	0.0035	0.9514	0.5076	1.0015
MgK	0.81	0.66	128.70	4.96	0.0052	0.9665	0.6600	1.0027
AlK	2.53	1.85	442.50	3.71	0.0183	0.9297	0.7762	1.0045
SiK	6.84	4.80	1270.60	2.95	0.0553	0.9491	0.8479	1.0054
S K	0.88	0.54	127.10	2.65	0.0076	0.9276	0.9207	1.0143
ClK	0.21	0.12	27.50	3.00	0.0018	0.8816	0.9503	1.0228
K K	0.46	0.23	48.30	3.09	0.0042	0.8756	0.9867	1.0518
CaK	28.51	14.02	2387.70	1.72	0.2543	0.8906	0.9949	1.0071
TiK	1.44	0.59	93.30	2.69	0.0113	0.8053	0.9628	1.0124
FeK	0.75	0.26	25.50	4.49	0.0060	0.7860	0.9926	1.0380



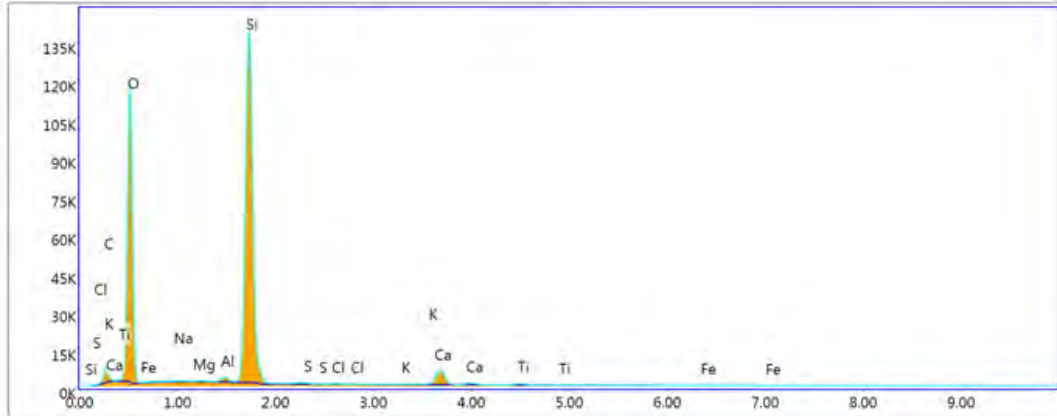
# SILICON PHASE – Si/O

## EDAX TEAM

Page 12

kV: 15      Mag: 200      Takeoff: 44.9      Live-Time(s): 114      Amp Time(μs): 3.84      Resolution(eV) 128.8

Phase: **SiK/O K**



Lsec: 114.0      1.308K Cnts      0.850 keV      Det: Octane Super A

### eZAF Smart Quant Results

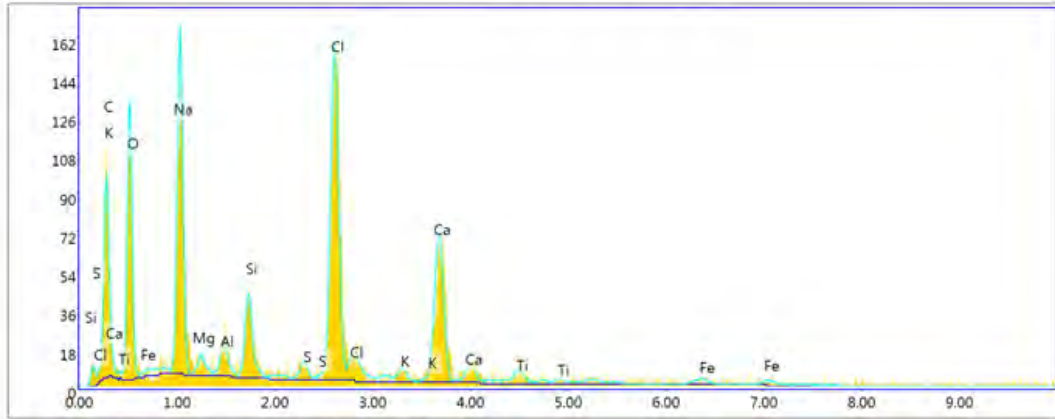
Element	Weight %	Atomic %	Net Int.	Error %	Kratio	Z	A	F
C K	8.48	13.63	265.30	10.26	0.0161	1.0934	0.1732	1.0000
O K	47.65	57.48	6147.00	7.44	0.1930	1.0418	0.3888	1.0000
NaK	0.12	0.10	19.80	23.34	0.0007	0.9414	0.5594	1.0027
MgK	0.13	0.10	30.70	10.81	0.0009	0.9562	0.7125	1.0053
AlK	0.60	0.43	158.30	5.00	0.0046	0.9196	0.8250	1.0096
SiK	36.95	25.39	10204.00	2.46	0.3117	0.9386	0.8970	1.0017
S K	0.18	0.11	33.40	21.30	0.0014	0.9170	0.8219	1.0052
ClK	0.08	0.04	12.50	32.94	0.0006	0.8714	0.8796	1.0086
K K	0.15	0.07	20.20	24.55	0.0012	0.8651	0.9501	1.0203
CaK	4.82	2.32	559.20	2.72	0.0417	0.8799	0.9686	1.0130
TiK	0.61	0.25	57.60	8.62	0.0049	0.7953	0.9827	1.0244
FeK	0.23	0.08	11.30	26.52	0.0019	0.7757	1.0011	1.0721

# CLORINE (Cl) PHASE – Cl/NaK/Ca/C/Si

## EDAX TEAM

kV: 15      Mag:200      Takeoff:44.9      Live-Time(s): 0.7      Amp Time(μs): 3.84      Resolution:(eV) 128.8

Phase: ClK/NaK/O K/CaK/C K/SiK



Lsec: 0.7    6 Cnts    0.850 keV    Det: Octane Super A

### eZAF Smart Quant Results

Element	Weight %	Atomic %	Net Int.	Error %	Kratio	Z	A	F
C K	26.22	42.07	671.10	16.67	0.0507	1.1103	0.1741	1.0000
O K	21.59	26.01	1257.10	13.46	0.0492	1.0584	0.2154	1.0000
NaK	13.84	11.61	1855.40	9.37	0.0772	0.9571	0.5819	1.0014
MgK	0.50	0.40	87.60	66.74	0.0031	0.9722	0.6332	1.0026
AlK	1.01	0.72	197.20	30.21	0.0072	0.9351	0.7514	1.0047
SiK	2.42	1.66	512.20	14.51	0.0195	0.9546	0.8370	1.0072
S K	0.64	0.39	109.50	43.33	0.0057	0.9330	0.9340	1.0193
ClK	17.86	9.71	2642.90	5.54	0.1539	0.8866	0.9611	1.0111
K K	0.89	0.44	100.90	52.99	0.0076	0.8805	0.9478	1.0257
CaK	12.75	6.13	1198.00	8.30	0.1112	0.8956	0.9654	1.0092
TiK	1.48	0.60	112.00	46.14	0.0118	0.8098	0.9685	1.0155
FeK	0.78	0.27	31.20	82.31	0.0064	0.7903	0.9952	1.0450

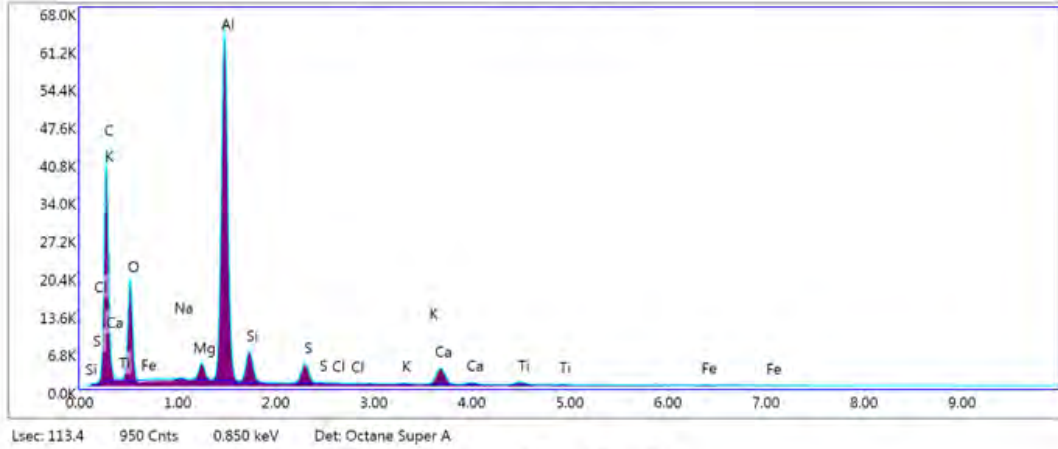
# CALCIUM (Ca) PHASE – Al/C/O/Si

## EDAX TEAM

Page 17

kV: 15      Mag: 200      Takeoff: 44.9      Live Time(s): 113.4      Amp Time(μs): 3.84      Resolution(eV) 128.8

Phase: **AlK/C K/O K/SiK**



### eZAF Smart Quant Results

Element	Weight %	Atomic %	Net Int.	Error %	Kratio	Z	A	F
C K	50.95	66.05	1904.80	8.70	0.1494	1.0607	0.2764	1.0000
O K	17.09	16.63	985.20	9.28	0.0401	1.0096	0.2322	1.0000
NaK	0.24	0.16	32.30	10.46	0.0014	0.9115	0.6475	1.0032
MgK	1.11	0.71	222.60	4.41	0.0082	0.9256	0.7889	1.0057
AlK	21.75	12.55	4510.80	2.71	0.1700	0.8900	0.8761	1.0025
SiK	2.12	1.18	390.00	4.82	0.0154	0.9083	0.7981	1.0033
S K	1.95	0.95	292.40	3.19	0.0158	0.8872	0.9100	1.0072
ClK	0.11	0.05	14.70	21.74	0.0009	0.8430	0.9386	1.0115
K K	0.21	0.08	22.70	14.99	0.0018	0.8368	0.9814	1.0256
CaK	3.32	1.29	296.00	2.88	0.0285	0.8510	0.9921	1.0191
TiK	0.82	0.27	59.70	6.29	0.0065	0.7691	0.9984	1.0325
FeK	0.33	0.09	12.80	23.24	0.0028	0.7497	1.0063	1.0898

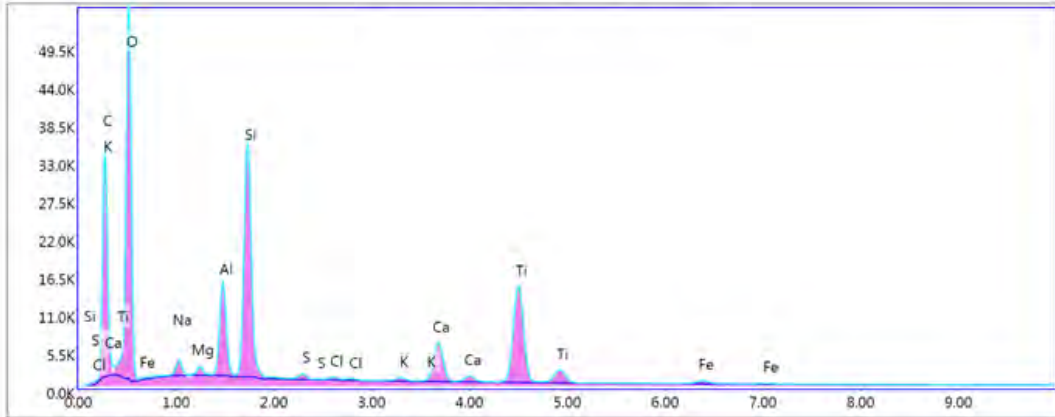
# TITANIUM (Ti) PHASE – O/Si/Ti/C/Al/Ca

EDAX TEAM

Page 18

kV: 15      Mag: 200      Takeoff: 44.9      Live Time(s): 193.7      Amp Time(μs): 3.84      Resolution(eV): 128.8

Phase: O K/SiK/TiK/C K/AlK/CaK



Lsec: 193.7      1.168K Cnts      0.850 keV      Det: Octane Super A

### eZAF Smart Quant Results

Element	Weight %	Atomic %	Net Int.	Error %	Kratio	Z	A	F
CK	24.16	37.23	814.20	8.28	0.0856	1.1018	0.3214	1.0000
OK	37.11	42.93	1701.20	9.04	0.0927	1.0502	0.2378	1.0000
NaK	0.98	0.79	81.30	8.61	0.0047	0.9495	0.5028	1.0014
MgK	0.38	0.29	49.30	7.41	0.0024	0.9646	0.6549	1.0027
AlK	3.96	2.71	566.40	4.03	0.0286	0.9278	0.7758	1.0041
SiK	10.00	6.59	1504.20	3.21	0.0797	0.9471	0.8388	1.0039
SK	0.32	0.18	36.60	10.80	0.0027	0.9256	0.9014	1.0106
ClK	0.22	0.11	22.30	9.69	0.0018	0.8797	0.9388	1.0169
KK	0.37	0.18	31.50	12.22	0.0033	0.8736	0.9815	1.0378
CaK	4.81	2.22	340.60	2.59	0.0440	0.8886	0.9916	1.0386
TiK	16.49	6.37	909.80	2.20	0.1336	0.8034	0.9954	1.0134
FeK	1.20	0.40	33.80	9.72	0.0097	0.7841	0.9953	1.0373

# SAMPLE 3A

DATE OF ANALYSIS – August 8<sup>th</sup>, 2020  
ANALYZED BY: J. FORD & H. Berdecía-Hernández

## EDAX TEAM

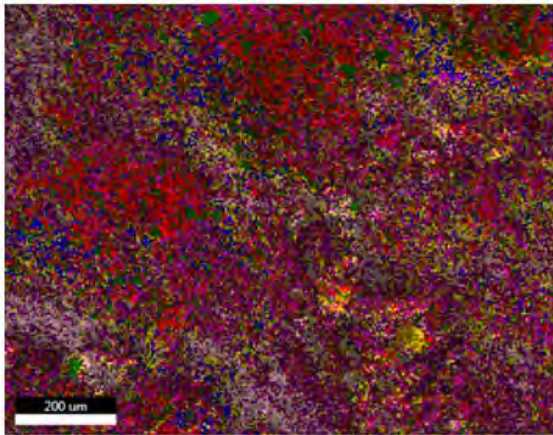
Page 1

### Hector

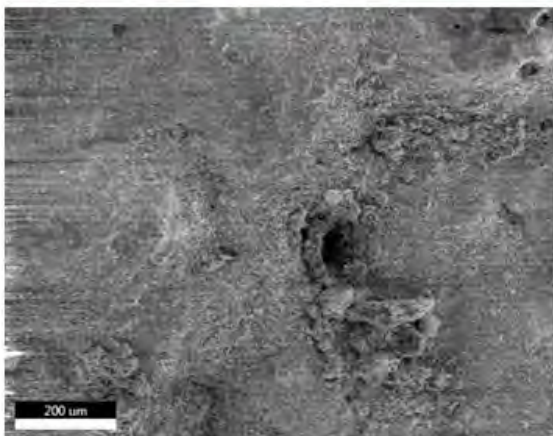
Author: prnuser  
Creation: 08/08/2020 2:46:25 PM  
Sample Name: 2A-1

### 3A

### PhaseROI 3



Notes:



Image

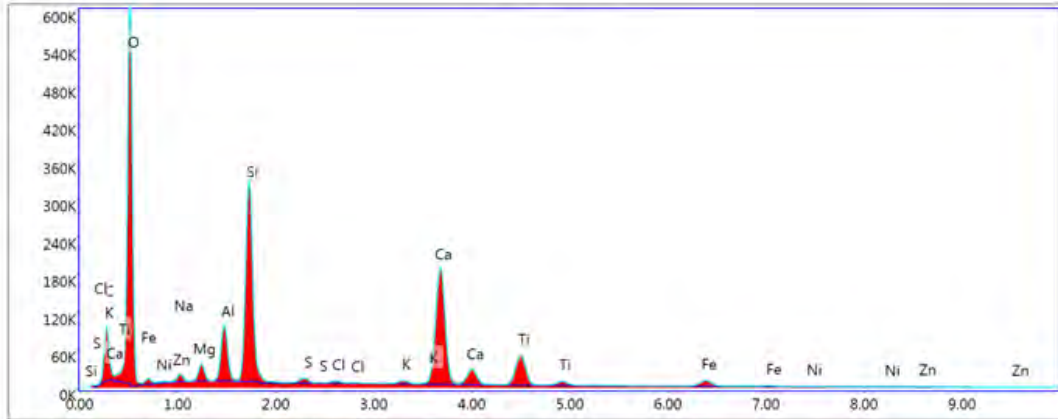
# SUM SPECTRUM

EDAX TEAM

Page 8

kV: 15      Mag: 250      Takeoff: 36.9      Live Time(s): 1310.7      Amp Time(μs): 3.64      Resolution:(eV) 128.4

Sum Spectrum



Lsec: 1310.7      20.959K Cnts      1.030 keV      Det: Octane Super A

eZAF Smart Quant Results

Element	Weight %	Atomic %	Net Int.	Error %	Kratio	Z	A	F
C K	7.46	12.88	516.70	8.57	0.0233	1.1187	0.2787	1.0000
O K	46.90	60.74	5487.10	8.79	0.1240	1.0667	0.2478	1.0000
NaK	0.54	0.49	98.90	9.08	0.0023	0.9648	0.4426	1.0014
MgK	1.02	0.87	302.30	5.58	0.0060	0.9801	0.5978	1.0025
AlK	3.19	2.45	1072.50	4.21	0.0219	0.9428	0.7243	1.0041
SiK	11.23	8.29	4089.30	3.37	0.0873	0.9625	0.8042	1.0041
S K	0.31	0.20	88.40	5.17	0.0026	0.9407	0.8758	1.0112
ClK	0.21	0.12	53.40	5.33	0.0017	0.8940	0.9204	1.0179
K K	0.40	0.21	85.40	4.20	0.0036	0.8879	0.9728	1.0408
CaK	18.66	9.65	3263.90	1.88	0.1688	0.9032	0.9855	1.0163
TiK	6.52	2.82	892.20	2.32	0.0524	0.8166	0.9680	1.0163
FeK	2.81	1.04	200.80	3.16	0.0230	0.7971	0.9920	1.0375
NiK	0.24	0.08	11.70	15.82	0.0020	0.7992	0.9965	1.0603
ZnK	0.51	0.16	14.50	13.86	0.0042	0.7494	1.0001	1.0919

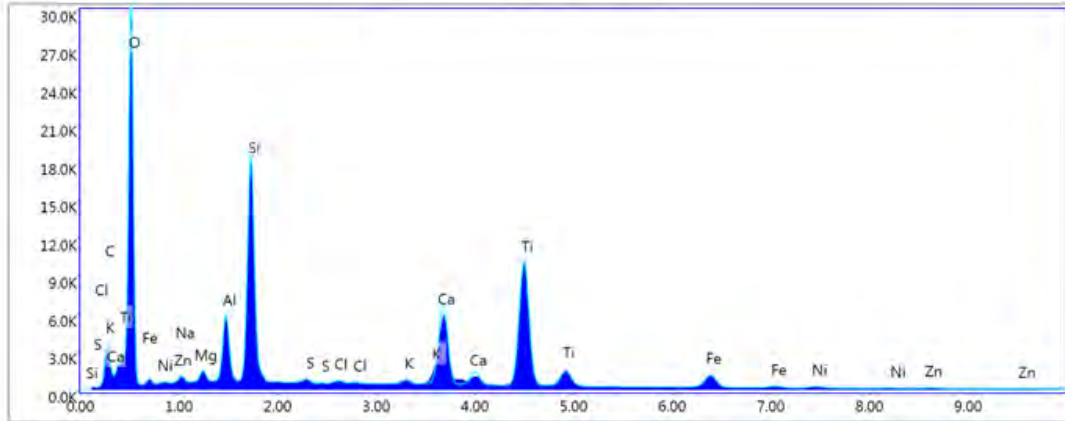
# TITANIUM (Ti) PHASE – O/Si/Ti/Ca/Al

EDAX TEAM

Page 9

kV: 15      Mag:250      Takeoff:36.9      Live Time(s): 88.1      Amp Time(μs): 3.84      Resolution:(eV) 128.4

Phase: O K/SiK/TiK/CaK/AlK



Lsec: 89.1      1.123K Cnts      1.030 keV      Det: Octane Super A

### eZAF Smart Quant Results

Element	Weight %	Atomic %	Net Int.	Error %	Kratio	Z	A	F
C K	4.42	8.38	275.40	9.80	0.0138	1.1501	0.2726	1.0000
O K	42.82	60.96	4117.10	9.23	0.1023	1.0975	0.2178	1.0000
NaK	0.41	0.41	62.90	17.26	0.0016	0.9934	0.3955	1.0011
MgK	0.55	0.52	141.70	8.39	0.0031	1.0094	0.5481	1.0021
AlK	3.11	2.62	933.30	5.14	0.0207	0.9711	0.6833	1.0035
SiK	10.22	8.29	3387.30	3.89	0.0785	0.9916	0.7719	1.0038
S K	0.16	0.12	43.50	23.64	0.0014	0.9695	0.8611	1.0105
ClK	0.22	0.14	52.30	16.92	0.0018	0.9215	0.9101	1.0167
K K	0.47	0.27	94.60	8.83	0.0043	0.9155	0.9673	1.0375
CaK	9.89	5.62	1665.60	2.39	0.0932	0.9314	0.9813	1.0320
TiK	21.21	10.09	2794.60	2.33	0.1775	0.8425	0.9799	1.0141
FeK	4.74	1.93	318.80	4.68	0.0395	0.8231	0.9854	1.0297
NiK	0.99	0.38	46.20	15.77	0.0085	0.8258	0.9912	1.0441
ZnK	0.79	0.28	20.90	29.28	0.0065	0.7748	0.9967	1.0665

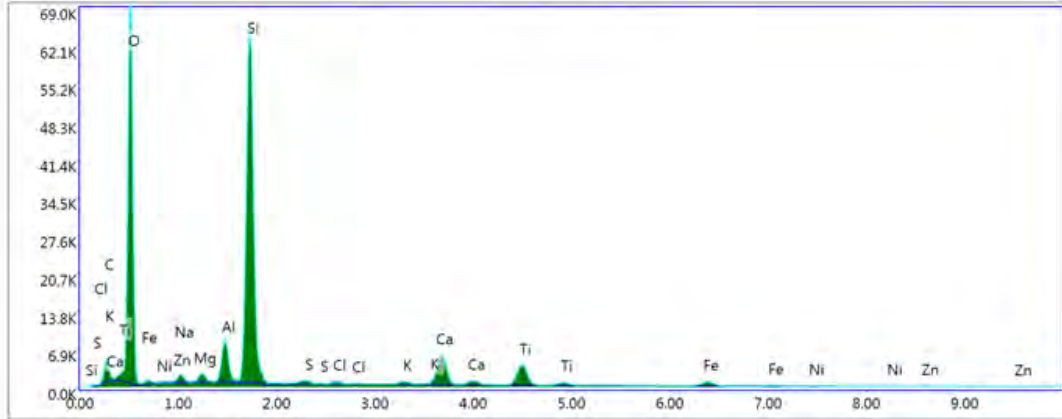
# SILICON (Si) PHASE – Si/O/Ca/Al

EDAX TEAM

Page 13

kV: 15      Mag: 250      Takeoff: 36.9      Live Time(s): 110.5      Amp Time(μs): 3.84      Resolution:(eV) 128.4

Phase:      SiK/O K/CaK/AlK



Lsec: 110.5      2.199K Cnts      1.030 keV      Det: Octane Super A

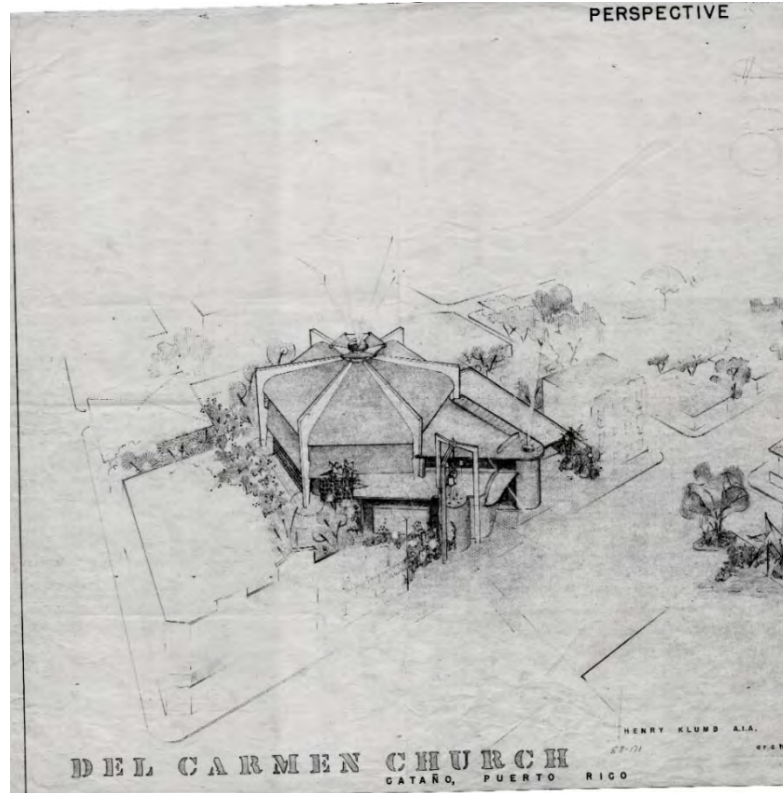
### eZAF Smart Quant Results

Element	Weight %	Atomic %	Net Int.	Error %	Kratio	Z	A	F
C K	6.67	11.22	321.20	10.17	0.0141	1.1114	0.1900	1.0000
O K	47.58	60.08	7300.60	8.19	0.1583	1.0593	0.3141	1.0000
NaK	0.63	0.56	126.80	11.05	0.0028	0.9577	0.4676	1.0018
MgK	0.65	0.54	208.40	6.81	0.0039	0.9728	0.6220	1.0033
AlK	3.00	2.25	1093.30	4.33	0.0211	0.9356	0.7485	1.0055
SiK	24.99	17.98	9746.80	3.20	0.1971	0.9551	0.8238	1.0025
S K	0.25	0.15	68.90	19.12	0.0019	0.9333	0.8219	1.0072
ClK	0.24	0.14	61.90	15.74	0.0019	0.8869	0.8804	1.0116
K K	0.45	0.23	97.40	10.39	0.0039	0.8807	0.9515	1.0264
CaK	6.44	3.25	1170.40	2.58	0.0572	0.8957	0.9697	1.0215
TiK	5.74	2.42	840.50	2.75	0.0466	0.8098	0.9802	1.0224
FeK	2.53	0.92	193.70	5.15	0.0210	0.7901	0.9973	1.0498
NiK	0.28	0.10	15.20	36.25	0.0024	0.7920	1.0001	1.0777
ZnK	0.55	0.17	16.70	29.96	0.0046	0.7423	1.0024	1.1150



# APPENDIX 16

## JOURNALS AND MAGAZINES



A16.1 - Drawing-Perspective of the Del Carmen Church. Source: Henry Klumb Collection, AACUPR.



A16.2 - Book Review of 'Architecture in Puerto Rico' featuring the Del Carmen Church at the San Juan Star Magazine on July 25, 1965, p. 6. Source: Henry Klumb Collection, AACUPR.

Nuestra Señora del Carmen

Construyen en Cataño Primera Iglesia en Forma Hexagonal

Por Aida Zarella
Hace pocos meses nos ca-

Ninguna de estas columnas
impide la vista hacia el al-

Ahora, la suerte nos vuel-

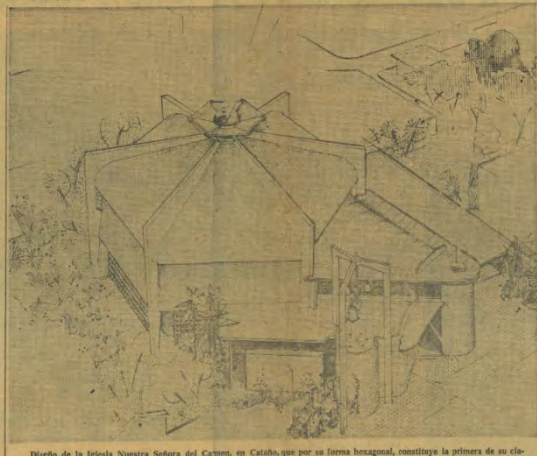
La Iglesia Nuestra Señora
del Carmen será una gara-

Con esta construcción, el
genio del arquitecto alemán

Las novenas y los tribus
ya no son a la devoción

Después del baptisterio, co-

Case Aranda, en Zaragoza,



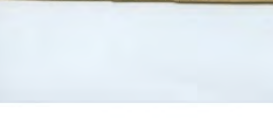
Diseño de la Iglesia Nuestra Señora del Carmen, en Cataño, que por su forma hexagonal, constituye la primera de su cla-

clamos se encuentra en el
centro de la iglesia, direc-

bloques de tierra cruda que
han sido colocadas cada una

Después del baptisterio, co-

Case Aranda, en Zaragoza,



esta casilla", dice el padre Lorenzo. Confeccionada



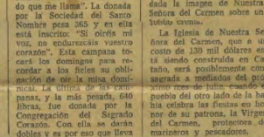
esta casilla", dice el padre Lorenzo. Confeccionada



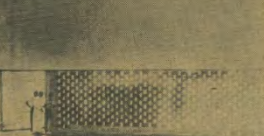
Un funcionario de la Casa Aranda, a cargo de la confección

dre Lorenzo que "los que
cantan en el coro forman

Los bancos en donde
están siendo subrogados en



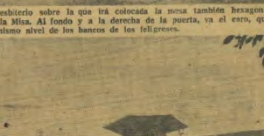
esta casilla", dice el padre Lorenzo. Confeccionada



esta casilla", dice el padre Lorenzo. Confeccionada



esta casilla", dice el padre Lorenzo. Confeccionada



esta casilla", dice el padre Lorenzo. Confeccionada



esta casilla", dice el padre Lorenzo. Confeccionada



esta casilla", dice el padre Lorenzo. Confeccionada

A16.3 - Article featuring the construction of the Del Carmen Church in El Mundo Newspaper, May 26th, 1962. Source: Henry Klumb Collection, AACUPR.

## Parish Church on a Caribbean Plaza

DEL CARMEN CHURCH • CATAÑO, PUERTO RICO • HENRY KLUMB, ARCHITECT • BERMUDEZ, HERNANDEZ & MURATI, STRUCTURAL ENGINEERS

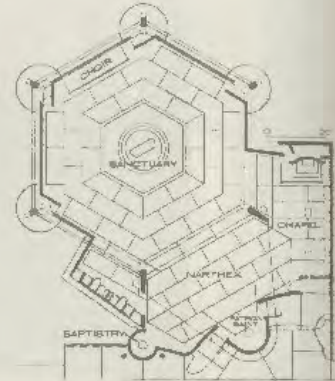
Across the bay from San Juan is the small town of Cataño, at its center a typical Spanish plaza with shaded promenade

and well-trimmed greenery. An old church facing the plaza was demolished to make way for the new Del Carmen Church.

To fit the church onto the small site, which is choked by buildings along its irregular boundaries, Klumb devised a hexagonal plan. Special requirements in this church for 500 people were a side

chapel within the church proper, and standing room at the rear for men (a local custom). The simple interior is centrally oriented to the altar and to the self-ventilating dome above. The bell tower, with electrically operated bells, is asymmetric to the plan but on axis with the plaza.

Reinforced concrete was selected as



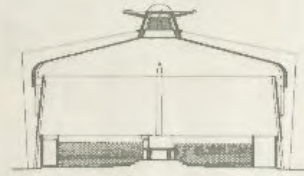
PHOTOS, EXCEPT AS NOTED, BY ITZAMAR SUAREZ

A16.4 - Del Carmen Church featured in the *Progressive Architecture* issue from November 1963. Source: Henry Klumb Collection, AACUPR.

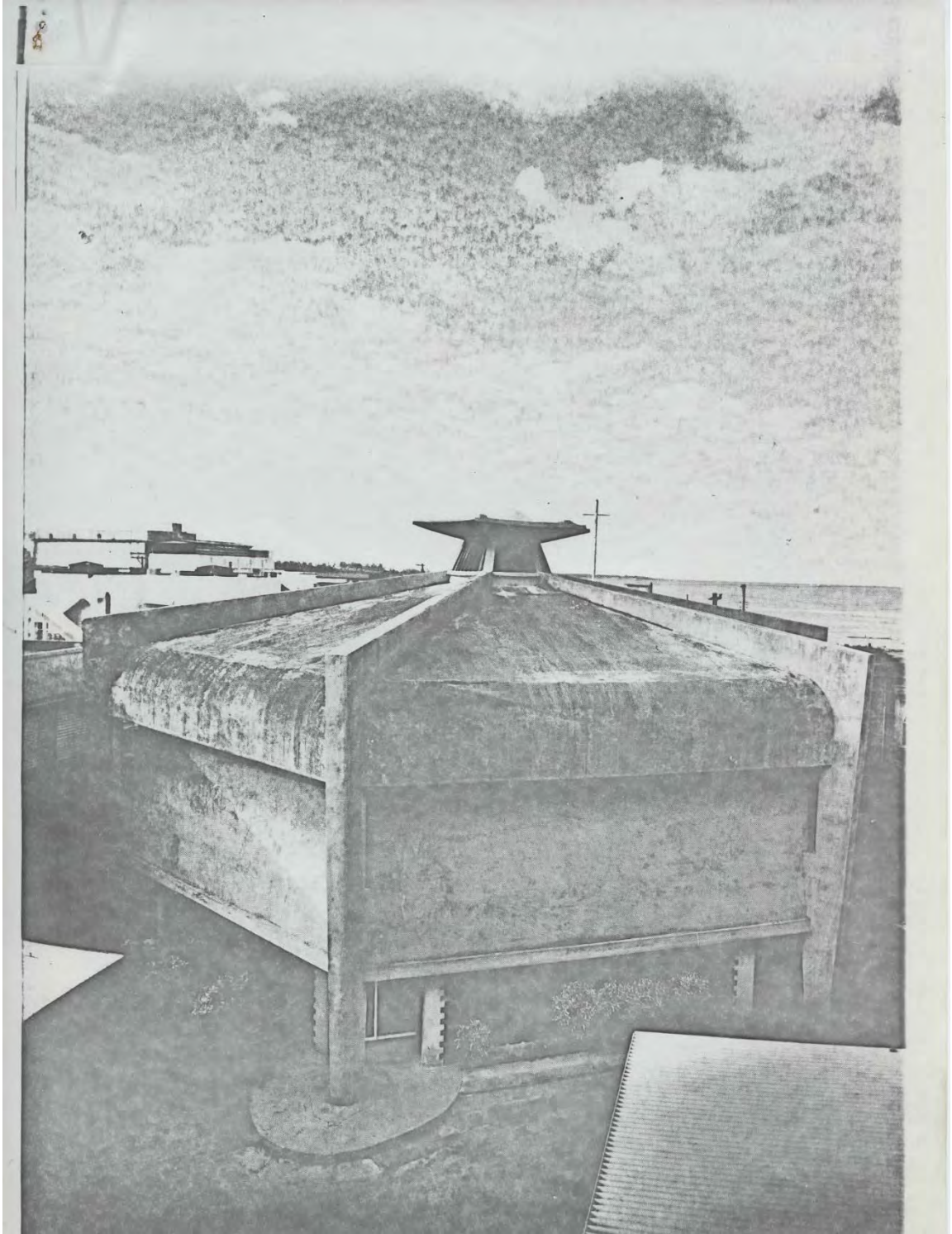
most economical for the design concept and for local construction methods. An earlier design, with Dr. August E. Komendant as engineer, was for precast concrete (see his article, "Concrete Technology," OCTOBER 1960 P/A), but costs forced the change to cast-in-place.

Forms are strong and simple: surfaces

are rough and unadorned. The roof, supported by columns only, is free from perimeter walls. Natural light also enters the main space through an 8-ft-high screen of clay tile. Exterior walls and floor surfaces are finished in cement. Plastered interior walls are light blue, with the ceiling painted a lighter blue.

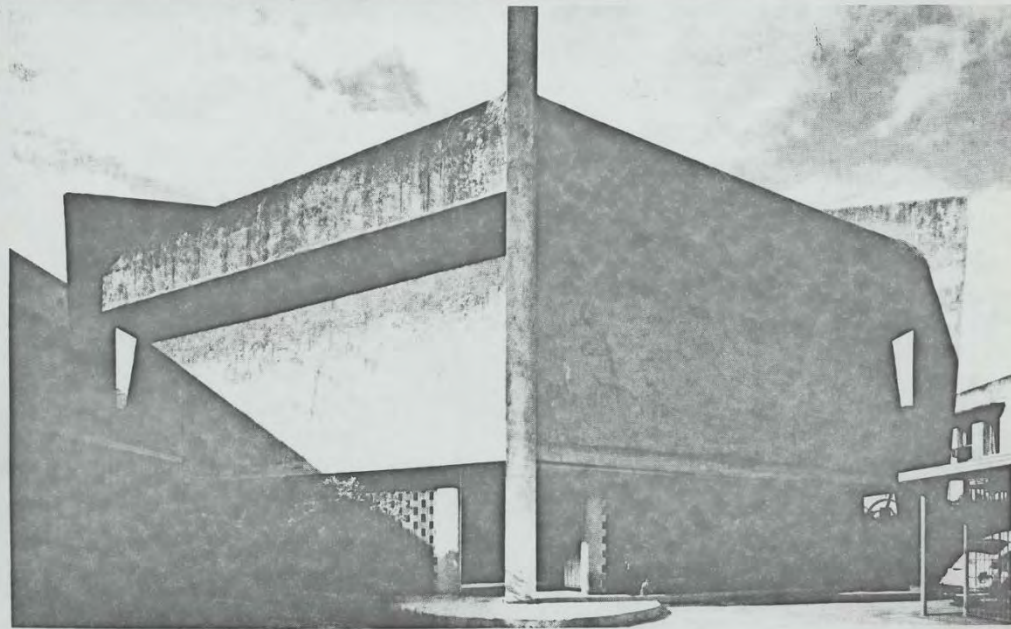
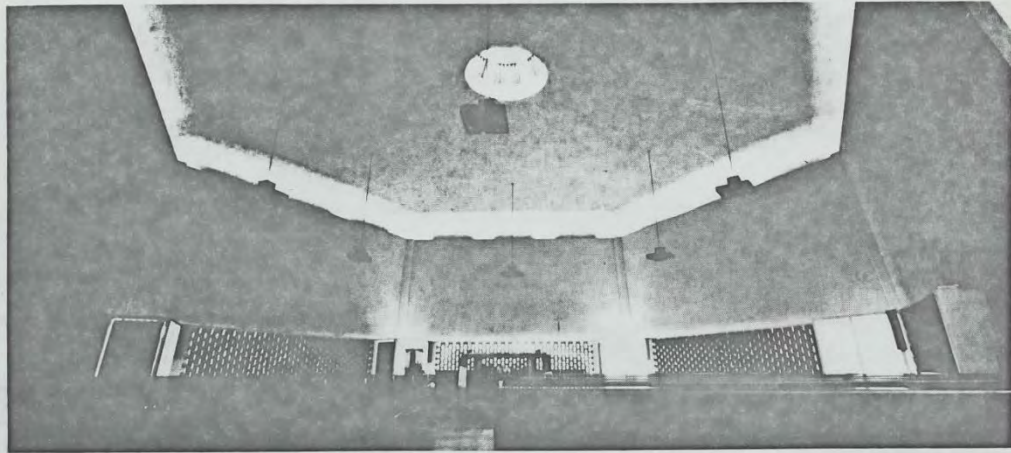


A16.5 - Del Carmen Church featured in the *Progressive Architecture* issue from November 1963. Source: Henry Klumb Collection, AACUPR.



A16.6- Del Carmen Church featured at the AIA Journal issue of July 1974. Source: JoAnn Crisp-Ellert, "Henry Klumb in Puerto Rico: Architecture at the Service of Society," *AIA Journal*, July 1974, p. 50-53.

The strong, seemingly sculpted form of Del Carmen Church 'is best representative of Klumb's philosophy.'



52 AIA JOURNAL/JULY 1974

A16.7 - Del Carmen Church featured at the AIA Journal issue of July 1974. Source: JoAnn Crisp-Ellert, "Henry Klumb in Puerto Rico: Architecture at the Service of Society," *AIA Journal*, July 1974, p. 50-53.



**IGLESIA EN CATANO, PUERTO RICO.**

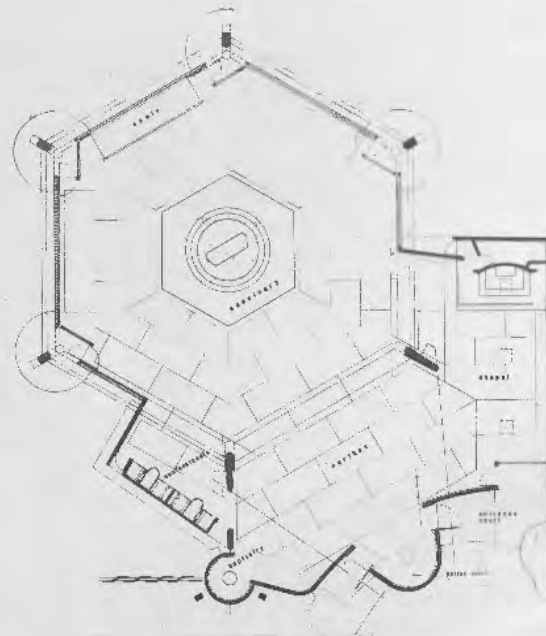
Interior de la iglesia del Carmen en la que se pueden apreciar los nuevos elementos con los que se realiza el culto.

Arq. Henry Klumb F.

La Iglesia Del Carmen es una iglesia parroquial para 500 feligreses y consta de un área de 7,000 pies cuadrados.

Los elementos de esta obra son:

- 1) La Iglesia
- 2) Una Capilla Lateral
- 3) Dos Confesionarios
- 4) Baptisterio del área de la Iglesia
- 5) Altar Mayor
- 6) Altar al Santo Patrón de Catano
- 7) Área del Coro con Orgáno Electrónico
- 8) Campanario con tres campanas operadas por electricidad.



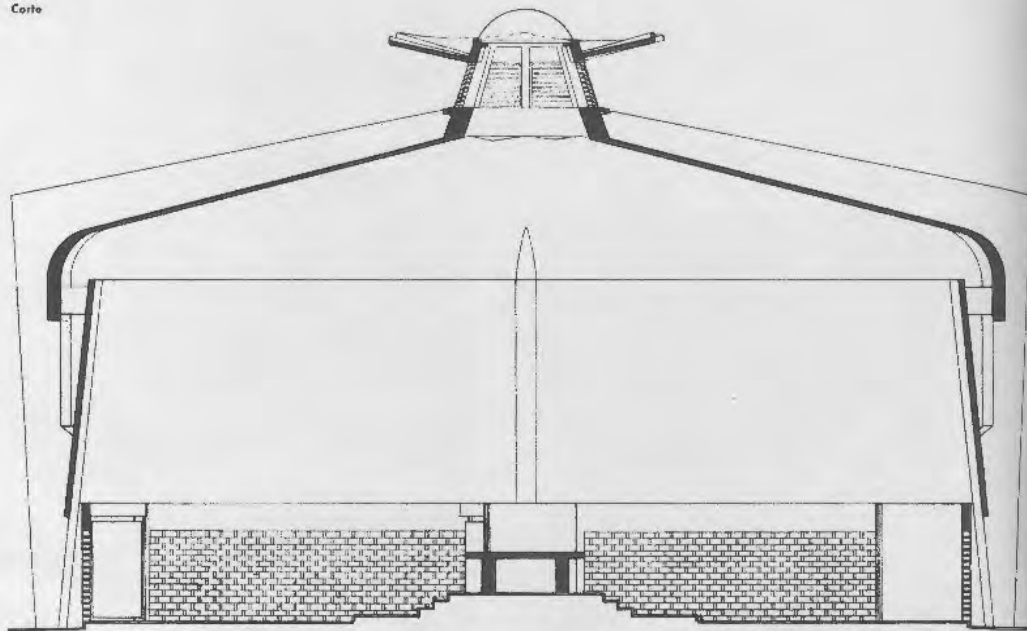
Planta

A16.8 - Del Carmen Church featured in the international *CALLI* magazine issue of March-April 1967. Source: *CALLI: Revista Analítica de Arquitectura Contemporánea*, March-April 1967, p. 49-51. Henry Klumb Collection, AACUPR.



Exterior de la iglesia del Carmen en Catano, Puerto Rico.

Corte



A16.9 - Del Carmen Church featured in the international *CALLI* magazine issue of March-April 1967. Source: *CALLI: Revista Analítica de Arquitectura Contemporánea*, March-April 1967, p. 49-51. Henry Klumb Collection, AACUPR.





Desde el patio interior se aprecia la estructura y las formas usadas en esta edificación.

Exterior de la iglesia.

#### Requerimientos Especiales:

- 1) Capilla Lateral en el área propia de la Iglesia.
- 2) Área libre de bancos en la parte trera de la iglesia para los hombres que prefieren permanecer de pie durante la misa, (Costumbre local).
- 3) Intercomunicación de la Iglesia con la rectoría ya existente.
- 4) La iglesia en si no tiene sacristía ya que usa una sacristía existente en la rectoría.

El local de la Iglesia del Carmen es un solar de 12,072 pies cuadrados localizado, frente a la Plaza, en el pueblo de Catano. El pueblo en si es pobre y esta separado de la capital, San Juan, por la bahía. El acceso al pueblo es por medio de un sistema de lanchas o por un recorrido alrededor de la bahía. Aunque el lugar es un poco incómodo, ya que esta rodeado por edificios de dos y tres plantas, ofrece un sitio centralizado con fácil acceso a los feligreses.

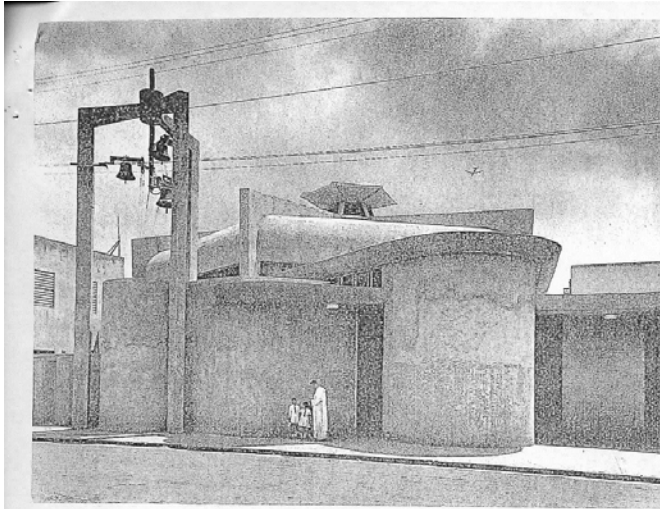
El problema de diseñar una iglesia en un lugar plano, rodeado de edificios de dos y tres plantas con solidancias irregulares y con problemas de ventilación y orientación dio lugar a la solución de un altar central rodeado por la congregación. Un enrejillado de concreto continua alrededor de la iglesia, excepto por los miembros estructurales a nivel del piso provee luz y ventilación. Una banda de concreto hasta el nivel del techo, levemente inclinada permite ventilación del techo. Un tragaluz en el centro provee luz para el altar central.

Concreto armado fue el material escogido como el más económico y el más propio para la mano de obra obreril. La terminación incluye empanetado para todas las superficies del concreto excepto el piso de cemento de color y el techo que lleva empanetado impermeable.

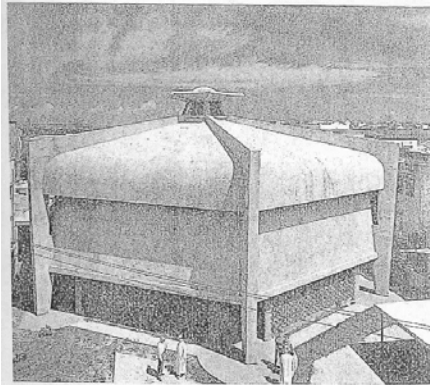
El exterior de la iglesia no fue pintado, la textura natural del cemento terminado dejada a la intemperie. Las paredes interiores son de azul claro, el techo interior de azul claro. El maderamen es de color natural de roaba.

EL AUTOR.

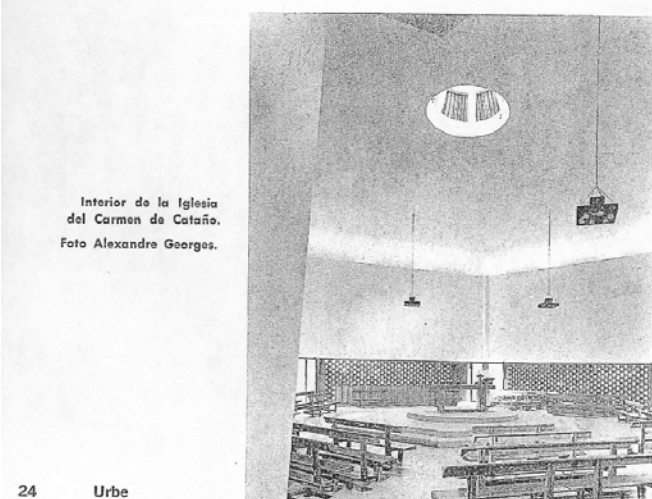




Iglesia del Carmen vista desde la Plaza de Cataño.



Volumen de la Nave Principal de la Iglesia del Carmen de Cataño, vista posterior.  
Foto Alexandre Georges.



Interior de la Iglesia del Carmen de Cataño.  
Foto Alexandre Georges.

ción han convertido a este templo en uno de los más importantes monumentos nacionales y en uno de los más preciados valores de nuestro patrimonio histórico y cultural. La labor de restauración inteligente lograda aquí por el Instituto de Cultura es ejemplo, al igual que lo son los otros casos de restauración logrados por esta institución en la isla. La capilla del fuerte de San Gerónimo es otro logro de restauración hecha con inteligencia y sensibilidad.

En el área metropolitana de Santurce, está enclavada la iglesia de San Mateo, adyacente al convento de sus monjas enclaustradas. Esta iglesia está considerada como uno de los más bellos ejemplos de la arquitectura religiosa de origen colonial de transición. La bóveda posterior de este templo es una de las mejores conservadas de esta época

Por desgracia han desaparecido varios templos en el interior de la isla, pertenecientes a este período histórico. La ignorancia de quienes ordenaron su demolición para construir estructuras "modernas", merece la censura de la historia.

Adelanto e inquietud en todas las expresiones, son los factores que motivan la nueva arquitectura religiosa en Puerto Rico. Después de los años del caos de la depresión económica de los años 30 se lograron en Puerto Rico dos iglesias que son transición entre lo antiguo y lo contemporáneo. La iglesia del Sagrado Corazón de Santurce, obra del Arquitecto Joseph O'Kelly, es la primera que cubre la nave principal de una iglesia en Puerto Rico, con la técnica de bóveda de cañón construida totalmente con hormigón armado. La otra Iglesia es la de San Jorge, obra del Arquitecto Rafael Carmoega, donde domina el espíritu plástico de inspiración en el pasado gótico. A los Padres Dominicos de Puerto Rico hay que

Continúa en la página 49

Iglesia del Carmen, Cataño. 1960 Puerto Rico 155  
Henry Klumb (US, born Germany, 1905–1984)



Exterior view, c. 1965. Photograph by Pedro Martínez. Henry Klumb Collection, Archivo Arquitectura y Construcción, Universidad de Puerto Rico, San Juan

The German-born and -trained architect Henry Klumb immigrated to the United States as a young man and apprenticed himself to Frank Lloyd Wright, who would remain an influence throughout his career, even as he developed his own practice. Klumb had an equally decisive relationship with Rexford Tugwell, an economist who was part of the brain trust assembled by Franklin D. Roosevelt to formulate the policies of the New Deal. After Tugwell was appointed governor of Puerto Rico in 1941, he called on Klumb to be his architect. Klumb arrived on the island in 1944 and remained there for the rest of his life.

In addition to his master plan for the Universidad de Puerto Rico, Río Piedras, Klumb left a legacy of innovative modernist churches. For the municipality of Cataño, adjacent to San Juan, he designed a centralized space in inexpensive concrete, with porous lateral walls to accommodate the Caribbean climate and a dome admitting zenithal light. Originally planned with the engineer August Komendant as a prefabricated piece to be shipped to the island, in the end the church was executed using simpler concrete techniques. BB



Interior view of the sanctuary, c. 1965. Henry Klumb Collection, Archivo Arquitectura y Construcción, Universidad de Puerto Rico, San Juan

A16.12 - Del Carmen Church featured at the MoMA Exhibition publication *Latin America in Construction: Architecture 1955-1980*. The exhibition was held from March 29<sup>th</sup>-July 19<sup>th</sup>, 2015. Barry Bergol, Carlos Eduardo Comas, Jorge Francisco Liernur and Patricio del Real, eds. *Latin America in Construction: Architecture 1955-1980* (New York, NY: MoMA Publications, 2015), 155.

La obra del maestro Klumb en Puerto Rico ha abarcado desde la arquitectura religiosa, educativa e industrial, hasta la residencial, donde se respira el fresco olor a naturaleza. Las distinciones y premios obtenidos por Klumb son innumerables y Puerto Rico se honra de tan preciada joya.

Sin duda alguna, la obra de Henry Klumb representa la más valiosa aportación al engrandecimiento y comprensión de la arquitectura contemporánea en Puerto Rico. Su estilo libre, sencillo, y de gran fluidez y continuidad, abarcó todas sus obras, reconciliando así la economía de sus construcciones y el efecto estético producido al tener a la "madre naturaleza" de consejera y compañera. La idea es, según Klumb,<sup>1</sup> "combinar lo que libremente nos provea la naturaleza", ya que hay que<sup>2</sup> "adaptar las estructuras al medio ambiente en vez del medioambiente a sus estructuras."

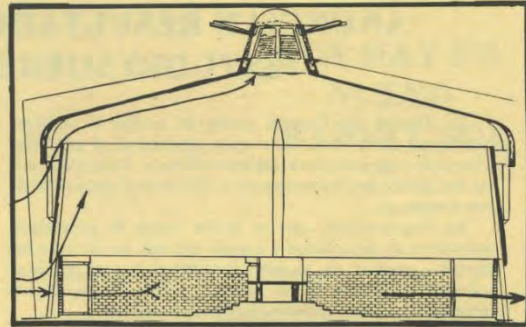
La residencia del arquitecto Klumb, rodeada de un majestuoso jardín es quizás la arquitectura que mejor responde a las exigencias de nuestro clima. Está diseñada de manera que no necesita un acondicionador de aire. Según Klumb,<sup>3</sup> "si en este país se hubiera diseñado la vivienda con el clima como primordial consideración, tampoco habría que usarlo. Es una pena que las personas que viven en urbanizaciones con techos bajos, y construidas sin consideración al clima tengan que depender del acondicionador de aire para vivir en una atmósfera agradable. El día de mañana quizás no haya petróleo, y entonces lamentaremos no haber tropicalizado la Isla."



El complejo farmacéutico de la Eli Lilly y Co.; en Carolina, está diseñado de manera tal que aprovecha la mayor cantidad de luz solar en sus edificios. Un jardín interior separa los edificios. "El hombre debe trabajar en contacto con la naturaleza", dice el arquitecto Klumb. Esta es de las principales consideraciones de Klumb al diseñar.

La Universidad de Puerto Rico es otra de las obras de Henry Klumb, donde se destacan, "la consideración en la orientación de los edificios a las brisas prevalecientes y la protección solar de sus estructuras". Los edificios de Ciencias Sociales, Pedagogía (antiguo), Comercio y Derecho, el Centro de Estudiantes, la Biblioteca General, el edificio de Servicios de Salud, la Residencia de Señoritas y el Museo Universitario, son parte de los diseños tropicales del arquitecto Klumb. Diseñó también los edificios del Recinto de Mayagüez de la Universidad de Puerto Rico.

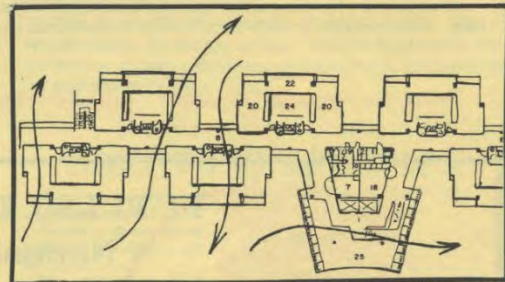
En Cataño diseñó bellas iglesias tropicales, como la Iglesia del Carmen y la Iglesia San Martín de Porres. Planificó, además, el convento e iglesia de Bayamón, la Iglesia de la Urbanización Santa María y el Colegio de San Ignacio de Loyola.



Como se observa en el diseño arquitectónico de la Iglesia del Carmen, en Cataño, la apertura de la parte más alta del techo facilita la salida del aire caliente hacia el exterior. Además, la superficie semi-abierta de bloques permite el flujo de las brisas a través de la estructura.

Otros edificios diseñados por Klumb son: el conjunto de la Parke Davis Co. y las fábricas de productos farmacéuticos Ely Lilly, ambos localizados en Carolina; el edificio de productos farmacéuticos Hofman La Roche, en Manatí y el Hotel La Rada en el Condado.

"Tropicalizar a Puerto Rico es un tema de actualidad, y siempre lo ha sido para aquellos que como el arquitecto Klumb han intentado hacernos ver a los puertorriqueños la bendición que es nuestro clima. Sin embargo, siempre sucede igual . . . los que no toman por sentado las bondades de la naturaleza, sabrán apreciarlas cuando las disfrutan, pero los que la reciben gratuitamente, no saben aprovecharlas al máximo."



En la Residencia de Señoritas de la Universidad de Puerto Rico, Recinto de Río Piedras, otro de los edificios diseñados por Klumb, los espacios abiertos en los pasillos entre los apartamentos facilitan el movimiento de la brisa. Los servicios se concentran en puntos donde no se obstruye la circulación del aire.

<sup>1</sup> Leopold Hohr, Henry Klumb y la unión con la naturaleza, El Mundo, P.R.: 1973

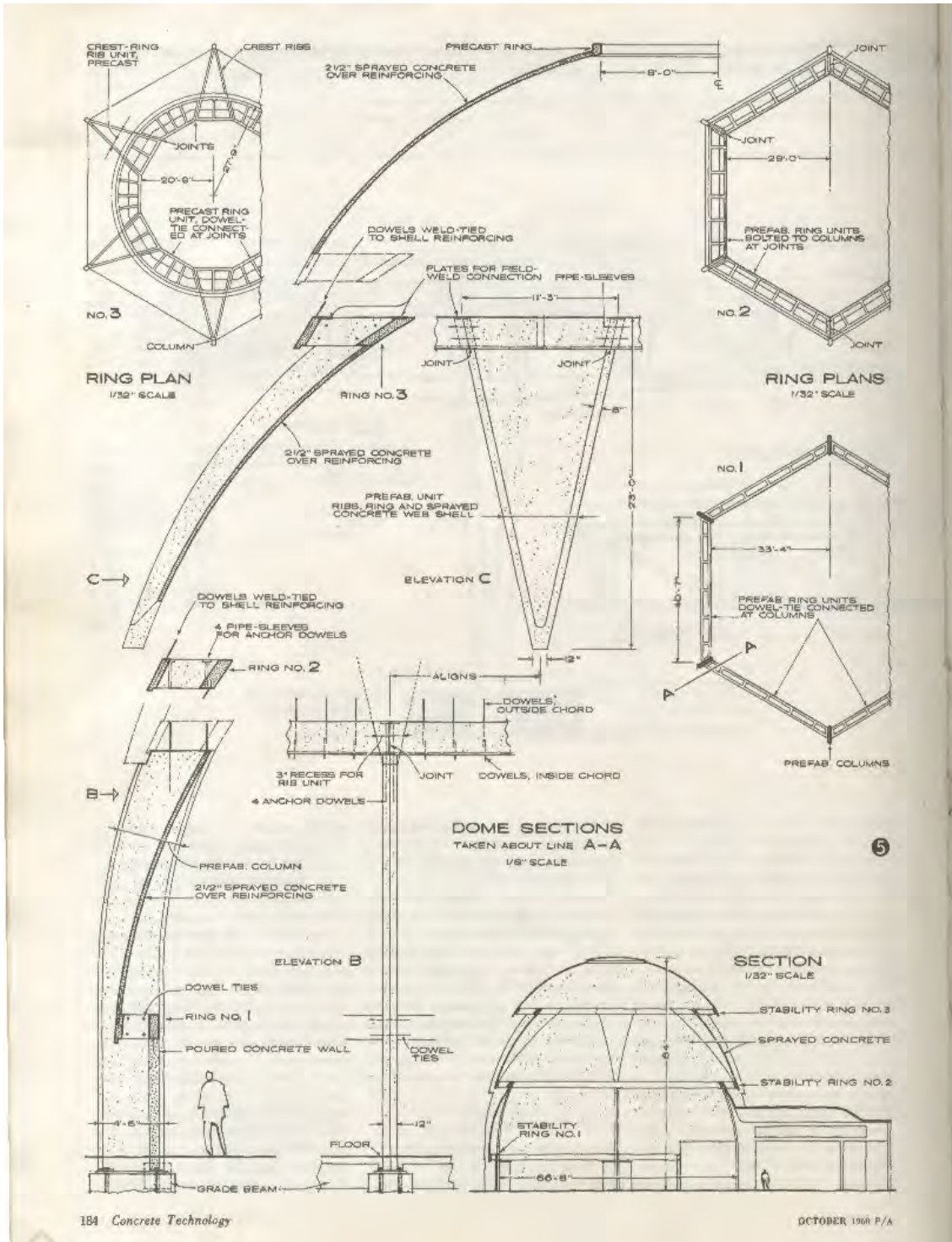
<sup>2</sup> Ibid

<sup>3</sup> Nydita S. de Rodríguez, Reto a la jungla de cemento, El Nuevo Día, P.R.: 1977

<sup>4</sup> La Gran Enciclopedia de Puerto Rico, Tomo 9, septiembre 1976, página 105

<sup>5</sup> Nydita S. de Rodríguez, Reto a la jungla de cemento, El Nuevo Día, P.R.: 1977

A16.13 - Del Carmen Church featured as an example of a successful passive ventilation system by a monthly publication of the Office of Energy Affairs of Puerto Rico in Feb 1982. Source: "La obra ejemplos de Henry Klumb: Un ejemplo vivo de la Arquitectura Tropical," *Cuentagotas* 4, No. 2, Oficina de Energía de Puerto Rico, February 1982, p. 45; Henry Klumb Collection, AACUPR.



A16.14 - The original Del Carmen Church design featured in the *Progressive Architecture* issue from October 1960. Source: Henry Klumb Collection, AACUPR.

name of job DEL CARMEN CHURCH job number 58-171  
 owner Dominican Fathers Location of Building: Cataño, Puerto Rico  
 agreement entered \_\_\_\_\_ work started January, 1959  
 preliminary plans: submitted March 24, 1960 approved \_\_\_\_\_  
 working drawings: submitted \_\_\_\_\_ approved \_\_\_\_\_  
 submitted to Planning Board \_\_\_\_\_  
 Planning Board objections \_\_\_\_\_ revisions submitted \_\_\_\_\_  
 date of approval by Planning Board January 14, 1960  
 submitted to bidders April 4, 1961  
 bid opening April 14, 1961  
 low bidder Carlos Lazaro Garcia \$ 98,695.68  
 other bidders Davis S. Castro, Inc. - \$150,000.00  
 \_\_\_\_\_  
 contract award Carlos Lazaro Garcia \$ 93,619.54  
 construction started \_\_\_\_\_ contract completion Dec. 18, 1962  
 actual completion \_\_\_\_\_  
 clerk-of-the-work \_\_\_\_\_ Dedication date: June 3, 1962  
 contractor's field engineer \_\_\_\_\_  
 sub-contractors: 1. \_\_\_\_\_ \$ \_\_\_\_\_  
 2. \_\_\_\_\_ \$ \_\_\_\_\_  
 3. \_\_\_\_\_ \$ \_\_\_\_\_  
 4. \_\_\_\_\_ \$ \_\_\_\_\_  
 5. \_\_\_\_\_ \$ \_\_\_\_\_  
 6. \_\_\_\_\_ \$ \_\_\_\_\_  
 estimated cost \$ 100,153.00 unit cost \$ 14.30 per sq. ft.  
 bid cost \$ 93,619.54 unit cost \$ 13.37 per sq. ft.  
 actual cost \$ 106,374.00 \* unit cost \$ 15.19 per sq. ft.  
 \_\_\_\_\_ 7,000 sq. ft. of construction

\*Plus cost of: Sound system \$1496.72, Pews \$4505., Altars \$1600, Bells \$3078.80, Piling \$7399.50.

A16.15 - Building description documents from 1963. Source: Henry Klumb Collection, AACUPR.

## DEL CARMEN CHURCH

Location: Catano, Puerto Rico

Date completed: June 3, 1962 (dedication)

Design credits:

Henry Klumb, A.I.A., Architect, San Juan, P.R.

BHM Engineers, Inc. (Structural), Roosevelt, P.R.

Carlos Lazaró García (General Contractor), San Juan, P.R.

Descriptive Data:

A Parish Church for 500 persons.

Area: 7,000 sq. ft.

Elements:

The Church proper

A side chapel

Two confessionals

A baptistry area within the church

A main altar

A patron saint altar

A choir area with an electric organ

A bell tower with three bells electrically operated.

Exceptional requirements:

A side chapel within the church proper

A standing area at the rear of the church for male attendance (a local custom).

Church intercommunication with existing rectory

No sacristy required since one is contained in the existing rectory

Description of Site:

A 12,072 sq. ft. lot on the main, Spanish style, central plaza of the town of Catano. The town is poor and is separated from the capital city of San Juan by the San Juan Port Bay. Its access to the city is by ferry boat or by a long loop around the bay. An existing church was demolished to clear the site for the present structure. Although the site is crowded, with two and three story buildings surrounding and choking it, it offers a centralized location with easy access to parishioners.

Design Approach:

The problem of designing a church for a crowded site, flat in topography, with irregular boundaries, and with ventilation and orientation problems, suggested the concept of a church with a central altar surrounded by the congregation. A continuous concrete open grille, except for structural members, at ground level provides light and ventilation and is surmounted by a concrete band up to roof level, slightly tilted to provide a ventilation opening between it and the roof. The skylight in the center provides a light source for the centrally located altar.

#### 7. Descriptive Data:

Reinforced concrete was the major material used throughout the project, selected as being the most economical construction method for the design concept and the local construction methods.

Finishes included cement plaster for all reinforced concrete members and surfaces with the exception of the floor finish of colored cement and the roof finish of waterproof cement.

The exterior of the Church was not painted, the natural textured cement finishes being left to weather. Interior plastered walls are painted a light blue, the ceiling a lighter blue. Millwork is in natural brown mahogany stain. The colored cement floor is beige.

#### 8. Cost Data:

The cost of constructing the building was \$106,374.00, a square foot cost of \$15.18. ✓

The cost of the soundsystem, pews, altars, bells, and piling totaled an additional \$18,080.00 ✓

A16.17 - Building description documents from 1963. Source: Henry Klumb Collection, AACUPR.



## APPENDIX 17



### INSTITUTO DE CULTURA PUERTORRIQUEÑA

PO BOX 9024184  
SAN JUAN DE PUERTO RICO 00902-4184

11 de junio de 2001

Padre Silvestre Gómez  
Párroco  
Parroquia Nuestra Señora del Carmen  
PO Box 427  
Cataño, Puerto Rico 00963-427

**Re: Pintura exterior, Iglesia Parroquial Católica Nuestra Señora del Carmen  
Cataño, Puerto Rico**

Estimado Padre Gómez:

El viernes 8 de junio visité la iglesia y pude constatar lo avanzado del recubrimiento con pintura del exterior del edificio. Este edificio no fue diseñado para ostentar colores sobre sus muros. El arquitecto a cargo del diseño fue Henry Kumb, conotado representante del movimiento internacionalista en la isla. Su legado arquitectónico es reconocido como de valor patrimonial. La arquitectura del Siglo XX debe de conservar sus mejores ejemplares como elementos enriquecedores de nuestro presente y futuro.

El edificio de la iglesia ha sufrido ya varias intervenciones indebidas según pude observar. Con el propósito de ayudarles a establecer un plan de conservación de esta notable edificación, solicitaremos la colaboración del Archivo de Arquitectura y Construcción de la Universidad de Puerto Rico.

Por lo tanto, le solicitamos descontinúe hasta nuevo aviso la intervención iniciada. La misma carece de los endosos y permisos requeridos por ley.

Cordialmente,

Arqto. Víctor J. López Reyes  
Conservacionista Región Norte  
División de Patrimonio Histórico Edificado

cc: Padre Mario Rodríguez - Vicarios Padres Dominicos

Administración de Reglamentos y Permisos -Oficina Regional de Bayamón

Dr. Enrique Vivoni  
Director, AACUPR

A17.1 - Letter from the Government of Puerto Rico-Institute of Puerto Rican Culture's Built Heritage Program, requiring Friar Silvestre Gómez to desist from painting the Church since it is not part of the building's original appearance and thus violates current Puerto Rico Heritage regulations. Source: Archives of the Built Heritage Program, Institute of Puerto Rican Culture.

## APPENDIX 16

### CONSTRUCTION CHRONOLOGY OF THE PARROQUIA NUESTRA SEÑORA DEL CARMEN

#### Timeline

- 1779** Ermita de La Candelaria founded in the Hacienda El Plantaje, located between Cataño and Toa Baja
- 1852** Spanish government authorized the establishment of the Compañía Puertorriqueña del Vapor Cataño - Real Order of May 6<sup>th</sup>, 1852
- 1860** Compañía de Vapor donates lands to the south of the public square plaza to construct a small chapel.
- 1864** Cataño neighbors requested permission for the development of lands surrounding the Chapel. The town's major, the Bayamón city administration, the Engineer, and the head of Public Works approved the request. From 1864 to 1889, the Chapel stood alone in the middle of the city block.
- 1889** Cataño neighbors requested permission for the development of lands surrounding the Chapel. The town's major, the Bayamón city administration, the Engineer, and the head of Public Works approved the request. From 1864 to 1889, the Chapel stood alone in the middle of the city block.
- 1893** A Canonical authorization to establish a Parochial Church in Cataño was received. The Church no longer responded to Bayamón.
- 1899** San Ciriaco Hurricane damages the wooden Church.
- 1904 – 1905** A new brick masonry church is built.
- 1905** Dominican fathers from Holland took charge of the Parochial Church.
- 1918** Tremors and the 1918 Earthquake damage the building.
- 1919** Only the main altar is restored.
- 1920** The Church is restored with new tile floors and new church pews for a total cost of \$1,236.82
- 1927** The Insular Legislative Assembly passed a bill creating the Municipality of Cataño as an independent municipal government.
- 1928** Hurricane San Felipe rips the Church's roof off and damages the building.

<b>1932</b>	Hurricane San Ciprián rips the Church's new roof off and leaves the building empty until 1933.
<b>1933</b>	Extensive renovations of the Church included eliminating columns for a free open space for the nave to host 200 people. A total of \$2,554.63 was invested in this project.
<b>1938</b>	The PRRA Cement factory was established near Cataño (Barrio Amelia).
<b>1940s</b>	Conversations started for the construction of a new 'bigger and solid' church
<b>1940 – 1950</b>	Deterioration of Cataño's economy and infrastructure
<b>1940</b>	The Puerto Rico Development Company or Fomento develop the first two factories in Cataño.
<b>1942</b>	Bacardí factory opens on the north side of Cataño
<b>1944</b>	Klumb designed the residence of Bacardí factory manager, don Pepín Bosch.
<b>1945</b>	Klumb worked on the development of the Residencial Matienzo Cintrón
<b>1946</b>	Bay View – the first private residential development in Puerto Rico- is built
<b>1948</b>	Klumb designed the Casa de los Trabajadores de las Lanchas de Cataño.
<b>1955</b>	December Letter from Klumb paying final dues and thanking Komendant for collaboration in a non-identified project – Office Building for Dr. Mario Julia.
<b>1957</b>	Father Lorenzo Booms, O.P. assigned to Nuestra Señora del Carmen
<b>1958</b>	A fundraising campaign started for the development of the new Church.
<b>1958</b>	Schematic designs started for the Del Carmen Church.
<b>1958 – 1959</b>	Komendant working with Structural Concrete Product Corporation on the Río Grande de Añasco Bridge (inaugurated in 1988) and the Puerto Rico Water Resource Authority
<b>1959 – January</b>	Project for Nuestra Señora del Carmen started.

- 1959 – Feb. 27<sup>th</sup>** Meeting with Father Domingo, Mr. Klumb, and Mr. Feheley. The following was agreed: a central altar conditioned of not losing seats in the Church, a Choir and existing altar, 3 confessionals (recessed 5' X 9'), a chapel for patron saint with an altar and no seats, a baptistry with an entrance from Church or salon in rectory, two-car garage, a large salon for meetings, a small altar boys room and a belfry with 3 bells from different sizes. They liked the idea of an enormous dome, but they were worried about leaks (they seemed worried about roof leaks, fungus, painting). The Friars requested a space with as much light as possible. This Space needed to be of easy maintenance, with enough air and minimum noise. Marxuach & Soto Surveyors suggested for the site survey.
- 1959 – Mar. 20<sup>th</sup>** Meeting with Father Domingo and E. Feheley. Report about the survey's progress. The lot limit was fixed for the School. Discussion regarding the approval from the Institute of Puerto Rican Culture (ICP) for the demolishing of the existing Church. Father Domingo mentioned that he would investigate the process to receive a letter that stated that the Church was not a historic monument.
- 1959 – April 8<sup>th</sup>** Komendant sent three design options for the dome and the main building – Shell 1-hexagonal, Shell 2 -only base hexagonal and top with 12 equal sides supported only at the corners of hexagonal shell 1, Shell 3 – circular or polygonal supported at 12 corners of shell 2. All using reinforced concrete. Shell 1 used poured concrete in a conventional way using forms, while Shell 2 & 3 could be built without forms (gunitite). He asked \$3,000 for his services.
- 1959 – April 16<sup>th</sup>** Meeting with Father Domingo & Father Lorenzo – Discussion of basic church plan composed of a 3' x 8' altar, a small choir area, seating-3'; the chapel (under consideration), and the structure. They were discussing economical solutions for the dome. The agreed solution was columns at the corner of the hexagon-center of the side aisle as long they could keep necessary aisle space around it. Waiting for the ICP's written response for demolition.
- 1959 – June 16<sup>th</sup>** Meeting with Father Lorenzo & E. Feheley – Progress of the Church: plans had been laid out on site accurately, and seating maintained the same. Next Steps: Preparation of a report for Zoning, preparation of preliminary plans, sections, and perspective for both the ICP and the Planning Board (JP). They were waiting for approval from the ICP and JP. Father Lorenzo asked for estimated costs (as soon size is established and materials selected, they'll tell him) and bell tower location (it was not located yet).
- 1959 – July 6<sup>th</sup>** Father Lorenzo called to check how the Church's drawings were progressing. Klumb told him that they would be ready at the end of the month, and they were waiting for the relocation of 'the road.'
- 1960** Klumb worked on developing the Capilla de San Judas Tadeo in the William Fuentes Neighborhood.

- 1960 – Jan. 14<sup>th</sup>** Planning Board approves construction project
- 1960 – Feb. 17<sup>th</sup>** Call with Father Lorenzo. They mentioned that Komendant was working with all designs. He would come to Puerto Rico in two weeks with final shell structures and estimates. The staff mentioned that they were working on drawings and estimated to get them ready in three weeks.
- 1960 – Feb. 17<sup>th</sup>** Meeting Dr. Komendant, F. Silvestre, E. Feheley, and J. Gelpí – Komendant questioned the Church's status. The Planning Board approved all plans exactly as submitted them (size, coverage, location), and they were now waiting on Komendant's structural ideas before working on the final drawings. Komendant was working on all calculation drawings and was coming to Puerto Rico in two weeks with the final drawings. Komendant also mentioned that he would work with Structural Concrete Products Company to prepare a quotation for all elements and the guniting. He suggested that a Soil test should be made to determine the site's bearing capacity. The skylight of the dome was also discussed as an entire pattern cast as four segments and brought to site assembled as a complete ring, hoisted into place, and the dome would be sprayed flush under it. The belfry was also discussed. They considered casting each support and anchoring everything by a top triangular bell support. A suggestion was made for all shells to use gunite, and all upper and lower rings precast.
- 1960 – Mar. 14<sup>th</sup>** Call with Komendant at NY. Komendant did not finish the estimate but would soon. He mentioned that he was going to Puerto Rico the next week and would discuss the estimate with Schalen. The assumed cost for all precasting and shells for the triple dome and main narthex shell was \$85,000. Komendant work was set to begin at 8' approx from grade. Footings – Komendant said all structural loads were vertical and very light, which would not need piles. They also discussed the overall costs.
- 1960 – Mar. 15<sup>th</sup>** Preliminary costs estimate 1 included a terrazzo floor finish, colored cement floor, marble finish, a precast grille, a cement plaster finish, AC for confessionals, plumbing, and electrical work, reinforced concrete, etc., initially. The Preliminary costs estimate 2 included rubbed finish for flat ceilings, rubbed finish for cap beams, beam & post columns, movable glass louvers, plain cement floor finish, metalwork in grilles, etc. (almost same as Preliminary cost estimates 1).
- 1960 – Mar. 16<sup>th</sup>** Report on Soil Exploration for Del Carmen Church – Cataño, Puerto Rico by Darío Hernández – BHM Engineers (Puerto Rico Testing Services, Inc-Consulting Engineers = BHM Engineers).
- 1960 – Mar. 23<sup>rd</sup>** Cost Estimates 3 – with precast structure and shell estimates

- 1960 – Mar. 24<sup>th</sup>** Meeting Father Visker, Father Lorenzo, Komendant, Mr. Schaelen, E. Feheley, J. Gelpí & F. Silvestre – Presentation of estimates: Dome at the top would be precast concrete, and the contract price was set to \$92,880. This not included seating, altars, landscaping, site improvements, AC for confessionals, architect fees, and building to the rear of Church. They scheduled a meeting on March 30<sup>th</sup> to discuss in-depth details. Mr. Schoalen said he was prepared to begin work as soon as the contract settled (Precast elements). The previous estimate from Komendant and Schoalen was \$148,000 before the revisions made by Komendant to original designs. In the meeting, there was no discussion of every detailed element on the estimates. Shoalen promised to submit along with Komendant a precise estimate.
- 1960 – Mar. 24<sup>th</sup>** Preliminary plans submitted.
- 1960 – Mar. 31<sup>st</sup>** Fee statement sent to Father Lorenzo - \$1,685 for preliminary plans, estimates, and specifications outlines. A fee computation information is available on the records.
- 1960 – June 6<sup>th</sup>** Meeting with Komendant, Father Lorenzo, Mr. Menoyo, F. Silvestre, and E. Feheley – Discussion of a low roof at the Church's front. It could be a flat roof of prestressed channel slabs. Komendant would develop structural specs and foundation design.
- 1960 – June 24<sup>th</sup>** Meeting Father Lorenzo and Father Visker. Discussion of the breakdown costs for the Church. They mentioned that Structural Concrete Product Corporation might request a more advanced payment than usual. Work possibly divided into two operations: precasting, piling, and assembling and work related to ordinary construction methods -cement floor, plastering, etc.
- 1960 – June 30<sup>th</sup>** Meeting with Mr. Scholen from Structural Concrete Products at Klumb's office. Plans/Drawings ready for him to start fixing his contract price. Grille in the garden was mentioned as economical and straightforward as could be designed. They agreed to send drawings to Komendant and Scholen. They were hoping to sign the contract by July 7<sup>th</sup>.
- 1960 – July 7<sup>th</sup>** Meeting with Feheley and Mr. Scholen at Structural Concrete Products. Klumb asked the Structural Concrete Products staff to call Komendant and ask for the complete structural drawings. Klumb felt they could not sign any contract without the structural drawings. Mr. Scholen agreed and mentioned that Father Lorenzo was anxious to sign a contract on the existing advanced copy with no specs. Structural Concrete Products offered to subcontract for the old church's demolition since piles were already cast at the Structural Concrete Products yard. They hesitated further church removal without a contract and outlined the next steps to sign the contract as quickly as possible, working with Komendant.

- 1960 – July 18<sup>th</sup>** Final Architectural drawings by Komendant received from Klumb's Office (Komendant says in letter to Father Lorenzo).
- 1960 – July 22<sup>nd</sup>** Komendant sent a letter to Klumb attaching the San Ignacio de Loyola Gymnasium preliminary drawings and a brief description. For the Del Carmen Church, Komendant mentioned that he was preparing the shop drawings and would mail them as soon as possible. He also said that there were no structural part changes and suggested going ahead with the contract.
- 1960 – Aug. 19<sup>th</sup>** Letter from Father Lorenzo to Komendant. Father Lorenzo mentioned that the old Church was demolished that week as scheduled, but drawings were not ready, and these needed approval from Komendant. Father Lorenzo begged Komendant to send the finished drawings.
- 1960 – Aug. 25<sup>th</sup>** Letter from Komendant to Father Lorenzo. Komendant mentioned that they received the final architectural drawings on July 18<sup>th</sup> with some minor changes, so he had to change earlier computations. Since the proposed type of shell was the most difficult to analyze, he had to study it by himself. He hoped to send all finished structural drawings by September 1<sup>st</sup>.
- 1960 – Sep. 9<sup>th</sup>** Letter from Komendant to Klumb. Komendant thanked Klumb for the August 24<sup>th</sup> letter. He discussed some changes regarding the design of the roof slabs. He would meet at Del Carmen Church with Structural Concrete people to discuss the project and other projects in Puerto Rico on September 13<sup>th</sup>.
- 1960 – Sep. 10<sup>th</sup>** Letter from WASCO Products, Inc. outlining recommendations for the dome skylight.
- 1960 – Sep. 13<sup>th</sup>** Klumb bought internal revenue stamps (Sellos de Rentas Internas) for Del Carmen Church.
- 1960 – Oct. 6<sup>th</sup>** Call from Mr. Fuentes (Gunitite Supplier) – actual cost for 2" thickness installed was about \$1.50/sq.ft. His preliminary estimates based on drawings are \$4.00/sq.ft. but promised to go back to Mr. Scholen to develop a more accurate quotation. The transcript mentions that "Fuentes referred to a manual in his possession entitled "Building Construction Data – 1959," which gave a price for Gunitite as 55 cents/sq. Ft. per 1" thickness, not including mesh or scaffolding. For 2 x 2x 12 mesh at this thickness, a price of 11 cents/sq. ft. was suggested..."
- 1960 – Nov. 2<sup>nd</sup>** Call with Dale Huntley – Huntley wanted to use hi-rib lath instead of gunitite work forms. He was somewhat concerned over the total thickness that would produce. He also wanted to use a san-hog air pump for an interior finish of 1" over 3/8" lath, but this method could only develop approximately 2000# psi. For the exterior work, he suggested a working at a strength of 3600# rather than 5000#, due

to costs. Huntley estimated this would represent approximately 25% costs reduction due to fewer stoppages and easier handling. In summary, the total thickness would be approximately 3 ½", or 1" cover – 3/8" horizontal steel – ¾" vertical steel – 3/8" lath and 1" plaster interior. The cost of job was greatly reflected by the scaffolding required (\$3,000 the first month, \$2,500 a second month, and \$2,000 per month after that). Huntley was convinced that time saved by the use of lath rather than forms would be better because of the building's heights.

- 1960 – Nov. 2<sup>nd</sup>** Komendant stated that they did not expect over 3000# psi for the gunite material and were ok with the use of metal lath and plaster for the interior surface. Komendant explained that the 'chicken wire' called for on plans was actually ¼" x ¼" wire mesh and that one later was to be superimposed on another. Additional thickness due to Huntley's use of a 3/8" rib lath would be no problem either.
- 1960 – Dec. 13<sup>th</sup>** Invitation to Bidders for Pile Foundations.
- 1960 – Dec. 19<sup>th</sup>** Office visit by Father Lorenzo – Mr. Feheley explained what they could do to lower the church costs within the budget. Father Lorenzo brought up the costs of architectural fees for redesign or not? Mr. Feheley explained that they had a moral obligation to design and built the Church within its budget but that this would be a discussion with Mr. Klumb for confirmation. Father Lorenzo asked for the time necessary for redesign and construction. Mr. Feheley stated that redesign could take 2-3 months at most and that construction (from beginning and piling to completion) required at least six months and probably up to nine at maximum.
- 1960 – Dec. 30<sup>th</sup>** Office visit from Father Lorenzo. He was concerned about the lack of sound system – Father Lorenzo was concerned about Plaza's noise, particularly for evening services.
- 1960 – 1961** Komendant worked with Luccarelli Associates for the Ponce Shopping Center and Bank in San Juan.
- 1961** Revisions – Major modifications from the original design.
- 1961 – Jan. 12<sup>th</sup>** Letter from Fidel to Bob – Mr. Saldaña for Fullana Corporation said they were interested in the project since they quoted \$48,000 and had not received an answer. Mr. Scholen (previously working at Structural Concrete) was now at the Fullana Corporation and told Saldaña that the job has gone to Structural Concrete. Mr. Saldaña offered a low quote of \$45,000.
- 1961 – Feb. 20<sup>th</sup>** Technical Specifications revised and updated.
- 1961 – Feb. 27<sup>th</sup>** Father Lorenzo came to see the perspective of the Church. He requested piling work to start by Holy Week (March 27<sup>th</sup>, 1961) as his superior was coming from Holland.



- 1961 – April 4<sup>th</sup>** Project submitted to bidders
- 1961 – April 10<sup>th</sup>** Notice to Bidders No. 1 – Addendum No. 1 to the Technical Specification for Textured Plaster Finish. Spray applied were called for in drawings textured plaster finish. Equipment – Spray equipment, mechanical mixer. Spray apply to a thickness of from 1/16" to 1/8".
- 1961 – April 11<sup>th</sup>** Letter from Dario Hernandez from Bermúdez, Hernández & Murati – estimation for services \$2,500 for structural design and preparation of structural drawings. They were not foreigners to the project since they did the Soil Survey Report in 1960 under the name of 'Puerto Rico Testing Services, Inc-Consulting Engineers.'
- 1961 – April 14<sup>th</sup>** Bid Opening Contractors– 3:00 pm – Architect's estimate – \$100,153 – Participates Carlos Lázaro (\$98,695.68) and David S. Castro, Inc. (\$150,000 with 300 Calendar days).
- 1961 – April 20<sup>th</sup>** Klumb bought internal revenue stamps (Sellos de Rentas Internas) for Del Carmen Church.
- 1961 – April 25<sup>th</sup>** Job Cost – Del Carmen Church Revision
- 1961 – April 28<sup>th</sup>** Invoice submitted to Klumb from Bermúdez, Hernández & Murati, Inc. Engineers for professional services- \$2,500.00
- 1961 – May 15<sup>th</sup>** First stone – foundations for the new Church
- 1961 – May 26<sup>th</sup>** Call to Father Lorenzo – Father Lorenzo said that piles are completed.
- 1961 – July 21<sup>st</sup>** Piles Contract with John Grozel? - \$7,499.50
- 1962 – Sept 17<sup>th</sup>** Mrs. Edith Battaglia – Cost of Painting \$2,145.93
- 1962** Father Nicolas Schokker, O.P. assigned to Nuestra Señora del Carmen
- 1962 – Feb. 25<sup>th</sup>** Fee Statements sent to Father Nicolas
- 1962 – July 8<sup>th</sup>** Bishop Jaime Davis officialized the blessing ceremony of the new Church.
- 1962 – Dec. 18<sup>th</sup>** Contract completion
- 1963 – June 3<sup>rd</sup>** Dedication date – Date completed
- 1963 – 1965** Father Manuel Keyser, O.P. assigned to Nuestra Señora del Carmen

# INDEX

## A

*ACI*... 103, 128, 151, 154-155, 156-157, 159, 176, 193, 198, 216, 262.  
*Absorption*... 120, 124, 190, 225-226  
*Aggregates*... 17, 102, 130, 131, 134, 141, 146, 154, 155, 220, 229, 230, 243  
    *Coarse*... 155-156, 159, 172, 184, 229  
    *Fine*... 116, 118, 123-124, 130, 172, 184, 229, 243-244  
    *Ferrous metallic*... 115, 116, 121, 123, 185-186, 193, 228, 234, 246, 249  
*Air Voids*... 216, 234, 238, 239, 249  
*Albite*... 243  
*ASR*... 193  
*ASTM*... 103, 118, 120, 132, 184, 193, 216, 232, 255, 262  
*Aragonite*... 235, 242-243, 250  
*August Komendant*... 70, 71, 73, 74, 127, 180  
*Auguste Perret*... 34-35

## B

*Bio/surface fouling*... 194, 195, 197, 199-200, 207  
*Brown coat*... 103, 106-107, 110, 112, 118, 126

## C

*Calcite*... 235, 237, 242-243  
*Calcium carbonate*... 116, 119, 191, 235, 238, 242  
*Carbonation*... 217, 222, 237, 242, 250, 262  
*Caribbean*... 3, 5, 8, 9, 23, 33, 38, 54, 87, 187, 209, 210, 265  
*Cataño*... 4, 5, 21, 29, 59, 60, 61, 64-66, 187-189  
*Cathodic Protection*... 212, 262-263  
*Catholic*... 5, 17, 33-36, 37-42, 57, 58, 60, 61, 83, 85  
*Chloride*... 191, 224, 243, 263  
*Cleaning*... 5, 134, 196, 199, 206, 207, 217, 254-256, 257-258  
*Coating*... 104, 160, 171-172, 186, 191, 197, 199, 203, 205, 235-236, 246, 253-257, 259-261

*Coat*... 103, 105, 106-107, 112, 114-116, 118, 122, 125-127, 131, 141, 148, 150, 154-156, 185-186, 235-236, 246  
*Concrete*... 1-3, 6, 8-10, 12-13, 20, 27, 33, 100-102, 104, 112, 116, 132-133, 135-136, 142, 144, 145, 151, 154-155, 171-172, 181-183, 195, 254-257, 259-263, 265-266  
    *Block*... 13, 18, 24, 27, 37-38, 55, 74, 76-77, 80, 114-115, 134, 146, 195  
    *Finishes*... 2, 12, 34, 61, 90, 83-84, 101-103, 104-108, 110-112, 114-116, 127, 131, 132-134, 140, 146-148, 156, 159-160, 184-187, 219, 264, 265  
    *Reinforced*... 9-10, 12-13, 17-18, 19, 27, 40, 74-76, 100-101  
*Conditions assessment*... 173, 176, 179, 250  
*Corrosion*... 122, 144, 191, 198, 205, 211-212, 222, 228  
    *Inhibitors*... 254, 257, 262-263  
*Cracks*... 115, 124-125, 132, 157, 160, 197-198, 199, 205, 211, 253, 264  
    *Hairline cracks*... 198, 205-206  
    *Large cracks*... 198, 205, 212  
*Crazing*... 132, 198, 205-206  
*Curing*... 115, 124, 130, 156-157, 195, 238

## D

*Del Carmen Church*... 3-4, 5, 61, 65-71, 83, 86-93, 104, 114, 160, 181, 191-193, 266  
*Detachment*... 197-199, 206, 212, 264  
*Dolomite*... 237, 242-243  
*Dominican Order*... 3, 36, 42, 44, 58, 60, 66, 69  
*Dry-mix*... 104, 127-129, 150-151, 153-154, 157, 249, 264

## E

*Efflorescence*... 223  
*Enfoscado*... 103  
*Empañete / Empañetado*... 100, 103

## F

*Ferrite*... 117, 124, 235, 243, 249  
*Frank Lloyd Wright*... 54-55, 84, 87

## G

*Gunitite*... 71, 73, 82, 103, 151-155, 253, 264 *also see*  
*Shotcrete*  
*Gypsum*... 100, 102, 117, 124

## H

*Hand application*... 103-104, 125, 154, 160-161, 185  
*Henry Klumb*... 3-4, 5, 32, 42, 54-61, 64, 69, 70, 73, 83-92, 96, 104-113, 127, 184-185, 188, 208, 212, 228, 235, 265

## I

*Iron*...  
    *filings see also ferrous metallic aggregate*... 115, 121-122, 156, 226, 228, 234, 239, 249  
    *oxide*... 117  
    *sulfide*... 243

## K

*Klumb see Henry Klumb*  
*Komendant see August Komendant*

## L

*Larnite*... 243  
*Le Corbusier*... 35, 81, 101  
*Lime*... 11, 100, 102-105, 116, 133-134, 150, 151, 156  
    *Hydrated lime*... 106, 114, 116, 119-120, 141, 142, 151, 206, 235, 243, 249-250  
*Loss of Stucco*... 197, 199, 206

## M

*Macroflora*... 197, 202, 207-208  
*Micro-chemical spot test*... 4, 216, 217, 227-229  
*Microdrop water absorption*... 4, 216, 217, 225-227  
*Microscopy*... 4  
    *Polarized light / Optical*... 185, 218, 229-231  
    *Scanning Electron*... 4, 216, 228, 244-248, 250 *see also* SEM-EDS

**N**

Nitratine... 243

Nozzleman... 129-130, 157, 160

**P**

Paint... 141, 142, 186-175, 193, 194, 206, 207, 236, 246, 250-251, 253, 255, 258

*Peeling of...* 202-203, 253

Permeability... 104, 112, 119, 122, 154, 202, 226, 249

Penetrant... 254, 259, 261, 262

Petrography... 4, 193, 216-217, 218, 222, 229-239

*see also Microscopy -Polarized*

Light

pH... 222

Phenolphthalein... 217, 218, 222

Phosphorus... 243

Pigeons... 204, 257

Plaster... 76, 92, 100, 102-103, 104, 114, 120, 133, 134, 146, 148, 150, 184, 217

Ponce Cement Corp... 24, 29

Porosity... 122, 123, 155, 157, 190, 202, 220, 225, 234, 230, 237, 249, 259, 262

Porous... 190, 191-192, 203, 235, 258, 262

Portland cement... 4, 8, 10-14, 21-23, 29, 32, 56, 91, 100-102, 104, 115, 116-118, 121, 124, 132-149, 154, 183, 189, 193, 212, 235, 249

*Stucco...* 4, 6, 91-92, 100-104, 105, 114, 115, 116, 118, 124-131, 132, 148-149, 181, 185, 187, 189-193, 205, 206, 207, 210, 215, 216-217, 219, 231, 233-234, 235, 249-250, 253, 257, 258, 264, 266

Portland Cement Association... 102, 119, 131, 146, 159

Poured-in-place... 76, 80, 81, 91, 105, 107, 114, 115, 144, 146, 182, 185, 190, 219, 220, 231, 234, 249, 259

PRRA... 19, 20, 23

Precast... 41, 71, 73, 74, 76, 77, 91, 117, 146, 147, 183, 186, 212, 219, 232, 236, 265

Puerto Rico... 3-6, 8, 9, 10, 11, 13, 17, 19-20, 23-25, 26, 28, 30, 31-32, 37-38, 41-42, 56, 57, 61, 100, 133, 144, 151, 160, 187-191, 195, 265, 266

Puerto Rico Cement Corp... 11, 21, 29

Pyrite... 243, 250

**R**

Repair... 2, 103, 133, 150, 152, 155, 192, 206, 254, 259, 263-264, 265

Repello... 103

Rising Damp... 190, 203, 204, 206, 207

**S**

Sea

*Spray...* 207, 243

*water...* 243, 250

Salts... 190, 192, 198, 199, 205, 207, 210, 218, 219, 223, 250, 256, 258, 259

*Crystallization...* 191, 199, 207

Sample... 216, 218, 219-220, 240, 243, 244

Sand... 106, 114, 115, 116, 118, 121, 122, 127, 160, 184, 235, 243, 249, 250

Scratch coat... 103, 106, 112, 125, 126

Second Vatican Council... 33, 83, 85

SEM-EDS... 4, 216, 217, 218, 228, 235, 244, 246, 250 *see also Scanning Electron*

Silica... 115, 116, 141, 154, 235

Silicate... 116, 117, 244, 261

Shrinkage... 112, 118, 124, 127, 144, 146, 154, 155, 183, 190, 198, 199, 238

Shotcrete... 41, 103-104, 105, 115, 118, 120, 125, 127, 128, 129, 130, 131, 149-161, 185, 206, 207, 226, 231, 234, 234, 249, 258, 264

Silane... 254, 257, 260, 262

Siloxane... 254, 257, 260

Soil... 76, 204, 206, 207, 208, 212

Steam... 254, 257, 258

Sulfate... 117, 119, 198, 224, 250

**T**

Tensile strength... 154

Terra cotta block... 80, 82, 88, 181

Treatment... 3, 5, 217, 253, 254-256

Trowel / Troweled... 82, 105, 107, 110, 112, 114, 115, 122, 127, 131, 134, 141, 148, 160, 185, 226, 233-235, 237-239, 249, 253, 259

**X**

XRD... 4, 216, 217, 218, 227, 239, 240-244, 250

**W**

Water-cement ratio – W/C... 104, 123, 130, 194, 226, 229, 234

Waterproof... 76, 151, 186, 228, 258

*Cement finish...* 112, 114-116, 120, 185

Workmanship... 102, 129, 130, 156, 157, 160, 192, 193, 195, 199, 216, 218, 229, 249

Wet-mix... 104, 127, 156, 158, 159, 264