

Title	Perseus, a New Genus of Jurassic Palaeoscenidiidae and the Phylogeny of Subfamily Hilarisirecinae
Author(s)	Takemura, Atsushi; Nakaseko, Kojiro
Citation	Memoirs of the Faculty of Science, Kyoto University. Series of geology and mineralogy (1983), 49(1-2): 111-118
Issue Date	1983-09-30
URL	http://hdl.handle.net/2433/186648
Right	
Type	Departmental Bulletin Paper
Textversion	publisher

Perseus, a New Genus of Jurassic Palaeoscenidiidae and the Phylogeny of Subfamily Hilarisirecinae

By

Atsushi TAKEMURA* and Kojiro NAKASEKO**

(Received March 31, 1983)

Abstract

Perseus hachimanensis n. gen., and n. sp., which belongs to subfamily Hilarisirecinae, is described. There are two different types (*Hilarisirex*-type and *Perseus*-type) of cephalic skeletal structures among hilarisirecins. A phylogenetic model of subfamily Hilarisirecinae based on cephalic skeletal structures is proposed.

Introduction

From manganese ore deposits in the Mino Terrane (HATTORI, 1982), central Japan, TAKEMURA and NAKASEKO (1982) described two new genera, *Hilarisirex* and *Diceratigalea*. They assigned those genera to family Palaeoscenidiidae and discussed the phylogeny and classification of Nassellaria and Palaeoscenidiidae. They possess cephalis in the apical hemisphere and thorax in the basal hemisphere (HOLDSWORTH, 1977). Subfamily Hilarisirecinae is proposed for these two new genera.

On the other hand, KOZUR and MOSTLER (1981), DUMITRICA (1982) and DE WEVER (1982) had described nassellarian forms which are named *Goestlingella*, *Foremanellina*, *Riedelius*, and so on. Their internal skeletal structures nearly accord with that of Hilarisirecins because they never possess dorsal spine (D) of Nassellaria.

Another form, which does not bear dorsal spine (D), too, occurred in the radiolarian assemblage from the manganese ore deposits in the Mino Terrane. (TKN-105, Figs. 1, 2; TAKEMURA and NAKASEKO, 1982). Although we assigned it to subfamily Hilarisirecinae, its internal skeletal structure is slightly different from that of *Hilarisirex* and *Diceratigalea*. It is almost identical to that of *Riedelius* sp. 2 De Wever. These difference of internal skeletal structures must reflect the phylogeny. We propose the phylogenetic model of subfamily Hilarisirecinae on the basis of these internal skeletal structures.

* Department of Geology and Mineralogy, Faculty of Science, Kyoto University. Kyoto 606, JAPAN.

** Institute of Geological Sciences, College of General Education, Osaka University. Toyonaka 560, JAPAN.

We wish to express our sincere thanks to Professor Tadao KAMEI, Professor Keiji NAKAZAWA and Dr. Niichi NISHIWAKI of Department of Geology and Mineralogy, Faculty of Science, Kyoto University for their valuable advice. Special thanks are due to Mr. Koji WAKITA of Geological Survey of Japan for his guidance in the field.

Phylogeny of Subfamily Hilarisirecinae

RIEDEL (1971) proposed the classification of polycystine radiolarians and classified Nassellaria mainly based on shapes and skeletons of cephalis. PETRUSHEVSKAYA (1971)

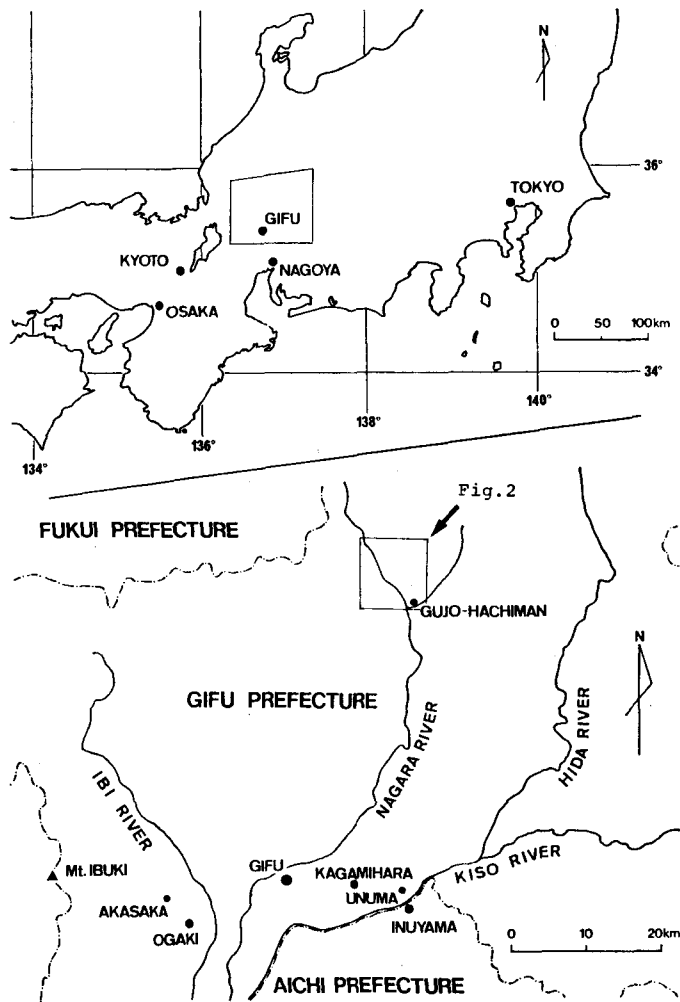

Fig. 1. Index map.

reported various cephalic skeletal structures of *Nassellaria* and classified them.

Such a skeletal structure as observed in cephalis of *Hilarisirecins* has not been reported from post-Jurassic radiolarians. Only Triassic and Jurassic forms possess this structure. They are *Goestlingella*, *Bipedis*, *Cuniculiformis*, *Riedelius*, *Foremanellina*, *Hilarisirex*, *Diceratigalea* and *Perseus* (KOZUR and MOSTLER, 1981; DUMITRICA, 1982; DE



Fig. 2. Locality map. (site plotted on Geographical Survey Institute of Japan topographical map "Hachiman" of scale 1:50000)

WEVER, 1982; TAKEMURA and NAKASEKO, 1982).

There are two distinguishable cephalic skeletal structures among subfamily Hilarisirecinae. One is observed in cephalis of *Hilarisirex quadrangularis* TAKEMURA and NAKASEKO, another is in *Perseus hachimanensis* TAKEMURA and NAKASEKO, n. gen., n. sp. (Fig. 3). In *Hilarisirex*-type (*H.*-type) structure, both lateral spines (L) and two secondary lateral spines (l) extend below to construct four feet. On the other hand, in *Perseus*-type (*P.*-type) structure, while lateral spines (L) extend below in the same way, two secondary lateral spines (l) do not extend and protrude straightly outside

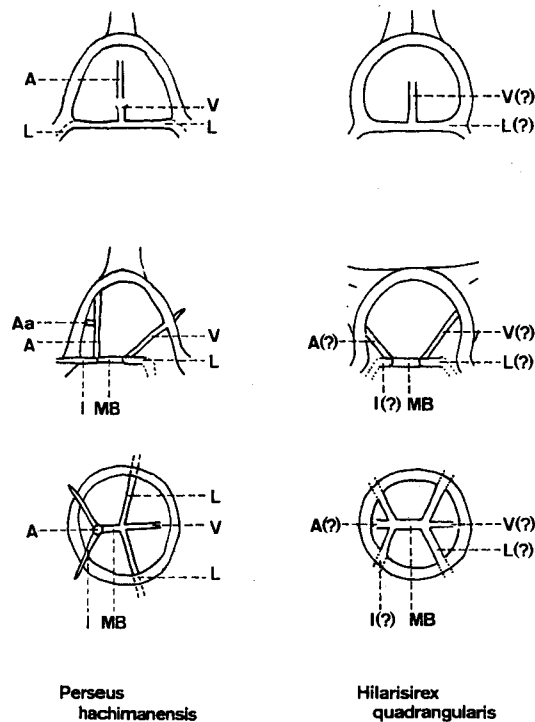

Fig. 3. Cephalic skeletal structures of *Perseus hachimanensis* TAKEMURA and NAKASEKO n. gen., n. sp. (left) and *Hilarisirex quadrangularis* TAKEMURA and NAKASEKO.

above: view toward side with vertical spine

middle: side view from position perpendicular to sagittal plane

below: view from apex

A: apical spine

V: vertical spine

MB: median bar

L: lateral spine

l: secondary lateral spine

Aa: apical appendage

Apical spine (A) and vertical spine (V) correspond to apical spines of Palaeoscoenidiidae and two lateral spines (L) and two secondary lateral spines (l) to basal spines.

of the shell. DE WEVER (1982) reported this situation as relationships between cephalic skeletons and feet.

P.-type structure is observed in cephalis of *Perseus hachimanensis* TAKEMURA and NAKASEKO, n. gen., n. sp., *P.* sp. A and *Riedelius* sp.2 DE WEVER. Genus *Hilarisirex*, *Diceratigalea*, and the other species of *Riedelius* possess *H.*-type structure (Fig. 5). At

PHYLOGENY OF FAMILY PALAEOSCENIDIIDAE

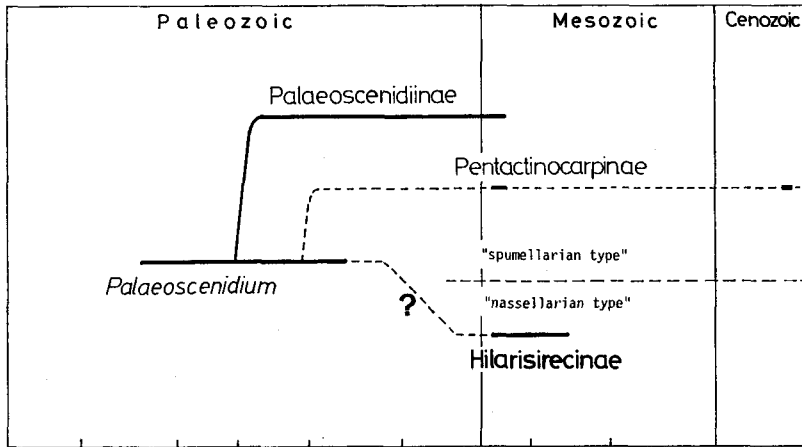

Fig. 4. Phylogenetic model of family Palaeosceniidiidae. (Paleozoic data are based on FURUTANI (1982), and Mesozoic and Cenozoic ones are on DE WEVER (1982), DUMITRICA (1978), KOZUR and MOSTLER (1981), NAKASEKO, NAGATA and NISHIMURA (1982) and TAKEMURA and NAKASEKO (1982))

PHYLOGENY OF HILARISIRECINAE

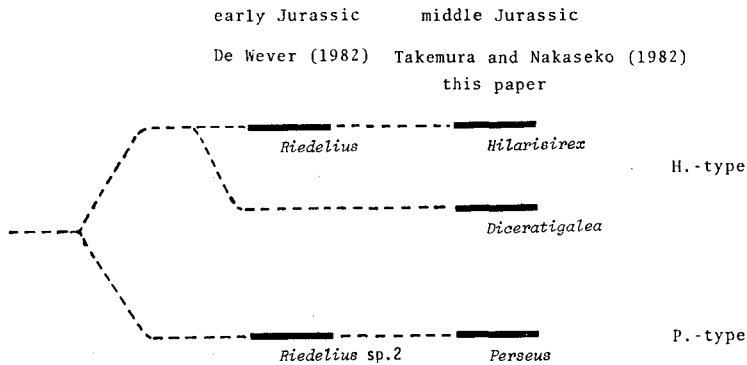

Fig. 5. Phylogenetic model of subfamily Hilarisirecinae. Phylogenetic positions of the other genera are obscure because cephalic skeletal structures of them have not been observed enough to determine to detail.

present, it is unclear which type the other hilarisirecins possess, because of the scarcity in observations of detailed cephalic skeletal structures by using SEM.

This difference of types of cephalic skeletal structures must reflect phylogeny. We propose a tentative phylogenetic model of subfamily Hilarisirecinae (Figs. 4, 5).

Systematic Paleontology

Subclass RADIOLARIA MÜLLER, 1858
 Order POLYCYSTINA EHRENBERG, 1838
 Family PALAEOSCENIDIIDAE RIEDEL, 1967, emend.
 HOLDSWORTH, 1977
 Subfamily Hilarisirecinae TAKEMURA and NAKASEKO, 1982

Genus *Perseus* TAKEMURA and NAKASEKO, n. gen.

Type species: -*Perseus hachimanensis* TAKEMURA and NAKASEKO, n. sp.

Diagnosis: -Test large and conical, composed of three segments, cephalis, thorax and abdomen. Strictures being at joints of chambers. Cephalis small and hemispherical, bearing an apical and a vertical horn. Thorax, in shape a truncated cone. Thoracic wall consisting of two layers, the inner latticed layer and the outer spongy one. Abdomen large and subspherical or hemispherical to truncated conical in shape, possessing latticed wall and a large circular aperture. Apophyses arising from around aperture.

Cephalic skeletal structure is shown in Fig. 3.

Remarks: -In the present paper, we discuss cephalic skeletal structures of hilarisirecins by using terms of Nassellaria (A, V, L, I, MB) for convenience.

Although total shape of this new genus resembles that of *Andromeda* BAUMGARTNER, the cephalic skeletal structure is quite different (BAUMGARTNER *et al.*, 1981). *Perseus* possess median bar (MB), apical spine (A), vertical spine (V), two lateral spines (L) and two secondary lateral spines (1) (Fig. 3). Dorsal spine (D) does not exist.

In *Hilarisirex* and *Diceratigalea*, two lateral spines (L) and two secondary lateral spines (1) construct four feet. But in this new genus, while lateral spines (L) extend to along the inside of thoracic wall, two secondary lateral spines (1) protrude outside of cephalic wall. Moreover, apical appendage (Fig. 3) exist at the dorsal side of apical spine (A). These differences suggest the phylogenetic difference between *Perseus* and *Hilarisirex* (Fig. 5).

Perseus hachimanensis TAKEMURA and NAKASEKO, n. gen. and n. sp.

(Pl. 9, figs. 1-2; Pl. 10, figs. 1-2)

Description: -Cephalis small, hemispherical and poreless, bearing a straight, rod-like apical horn. Vertical horn arising as a prolongation of vertical spine (V). Two

secondary lateral spines extending outside of the cephalic wall. Thoracic inner lattice wall covered by outer spongy one, except immature specimens. Inner lattice wall possessing circular pores with polygonal pore frames. Abdominal wall latticed with large, circular to elliptical pores encircled by polygonal, mainly hexagonal pore frames. Pores arranged in longitudinal rows. At the base of abdomen, large circular aperture situated. Some secondary network observed in abdominal pores of some mature specimens. 6 to 9 apophyses, which are triradiate proximally and rod-like distally, rising around aperture.

Measurements:-Length of shell (exclusive of apical horn and apophyses), 200-260 μm ; Maximum width of shell, 220-290 μm ; Length of abdomen, 130-180 μm .

Remarks:-All of the abdominal pores are not arranged in longitudinal rows. Some are small and irregularly distributed (Pl. 10, fig. 1). Secondary network of abdomen is probably the initial stage of the formation of thoracic outer spongy layer.

Occurrence:-TKN-105 (Jurassic manganese ore deposits in the Gujo-Hachiman area, Mino Terrane, Central Japan)

Perseus sp.A

(Pl. 10, fig. 3)

Description:-Total shape and cephalo-thorax same as *Perseus hachimanensis*. Abdominal wall possessing large, irregularly distributed pores of which shapes are irregular.

Remarks:-This species is distinguished from *Perseus hachimanensis* by the arrangement of abdominal pores. No species name is given because of its scarcity.

Occurrence:-TKN-105

REFERENCES

- BAUMGARTNER, P. O., DE WEVER, P. and KOCHER, R. (1980) Correlation of Tethyan Late Jurassic-Early Cretaceous Radiolarian Events. *Cah. Micropaleont.*, **1980-2**, 23-72.
- DE WEVER, P. (1982) Nassellaria (Radiolaires Polycystines) du Lias de Turquie. *Rev. Micropaleontologie*, **24**(4), 189-232.
- DUMITRICA, P. (1978) Triassic Palaeoscenediidae and Entactiniidae from the Vincentinian Alps (Italy) and Eastern Carpathians (Romania). *D. S. Inst. Geol. Geofiz.*, **64**(3), 39-54.
- DUMITRICA, P. (1982) Foremanellinidae, a new family of triassic Radiolaria. *Dari Seama Sedint.*, Bucarest, **67**(3).
- FURUTANI, H. (1982) Skeletal Construction and Phylogeny of Palaeoscenediidae. *JRS 81 Osaka, Proceedings of the First Japanese Radiolarian Symposium, News of Osaka Micropaleontologists, Spec. Vol. 5*, 11-18, 1pl. (in Japanese with English Abstract).
- HATTORI, I. (1982) The Mesozoic Evolution of the Mino Terrane, Central Japan: A Geologic and Paleomagnetic Synthesis. *Tectonophysics*, **85**, 313-340.
- HOLDSWORTH, B. K. (1977) Paleozoic Radiolaria; Stratigraphic distribution in Atlantic borderlands. in SWAIN, F. M. ed., *Stratigraphic Micropaleontology of Atlantic basin and borderlands*, 167-184, Elsevier, Amsterdam.
- KOZUR, H. and MOSTLER, H. (1981) Beiträge zur Erforschung der mesozoischen Radiolarien. Teil IV:

- Thalassosphaeracea HAECKEL, 1862, Hexastylacea HAECKEL, 1882 emend. PETRUSEVSKAJA, 1979, Spongruacea HAECKEL, 1862 emend. und weitere triassische Lithocycliacea, Trematodiscacea, Actinommacea und Nassellaria. *Geol. Paläont. Mitt. Innsbruck Sonderbd.* 1–208.
- NAKASEKO, K., NAGATA, K. and NISHIMURA, A. (1982) Discovery of Miocene Radiolaria belonging to Pentactinocarpinae in Japan (Preliminary Report). *JRS 81 Osaka, Proceedings of the First Japanese Radiolarian Symposium, News of Osaka Micropaleontologists, Spec. Vol. 5*, 423–426, (in Japanese with English Abstract).
- PETRUSHEVSKAYA, M. G. (1971) On the natural system of polycystine Radiolaria (Class Sarcodina). in *Proc. Second Planktonic Conf., Roma, 1970* Edizioni Tecnoscienza, Rome, 981–992.
- RIEDEL, W. R. (1971) Systematic classification of polycystine Radiolaria. in FUNNELL, B. M. and RIEDEL, W. R. eds., *The micropaleontology of oceans*, Cambridge University Press, 649–661.
- TAKEMURA, A. and NAKASEKO, K. (1982) Two New Jurassic Genera of Family Palaeosцениidae (Radiolaria). *Trans. Proc. Palaeont. Soc. Japan, N. S.*, **128**, 452–464.

Explanation of Plate 9

Figs. 1-2. *Perseus hachimanensis* TAKEMURA and NAKASEKO n. sp.

Fig. 1. Holotype, ATJRMN-1105-1, TKN-105

1-a. lateral view (scale=100 μ m)

1-b. cephalis and thorax (scale=50 μ m)

1-c, d. cephalic skeletal elements, stereophotographs (scale=50 μ m)

1-e, f. basal view, stereophotographs (scale=100 μ m)

Fig. 2. Paratype, ATJRMN-1106-1, TKN-105

2-a. lateral view (scale=100 μ m)

2-b, c. cephalic skeletal elements, stereophotographs (scale=50 μ m)

(Abbreviations are same as Text-fig. 3)

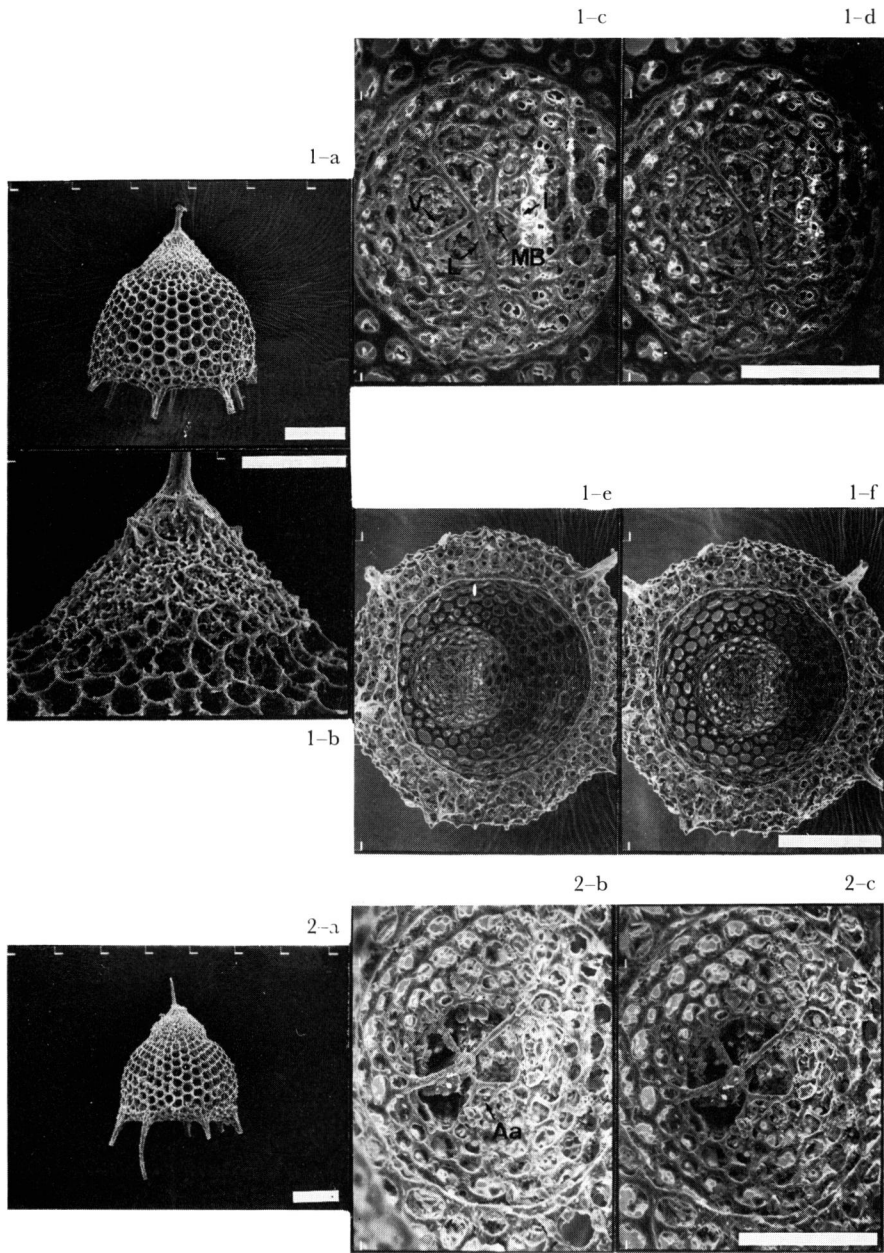

TAKEMURA & NAKASEKO: *Perseus*, a new genus of Jurassic Palaeosconidiidae

Explanation of Plate 10

- Figs. 1-2. *Perseus hachimanensis* TAKEMURA and NAKASEKO, n. sp.
- Fig. 1. Paratype, ATJRMN-1105-2, TKN-105
- 1-a. lateral view (scale=100 μ m)
- 1-b, c. cephalic skeletal elements, stereophotographs (scale=10 μ m)
- Fig. 2. Paratype, ATJRMN-1105-3, TKN-105
- 2-a. lateral view (scale=100 μ m)
- 2-b. secondary network of abdomen (scale=50 μ m)
- 2-c, d. basal view, stereophotographs (scale=100 μ m)
- Fig. 3. *Perseus* sp. A, ATJRMN-1106-2, TKN-105
- 3-a. lateral view (scale=100 μ m)
- 3-b, c. basal view, stereophotographs (scale=100 μ m)
- (Abbreviations are same as Text-fig. 3)

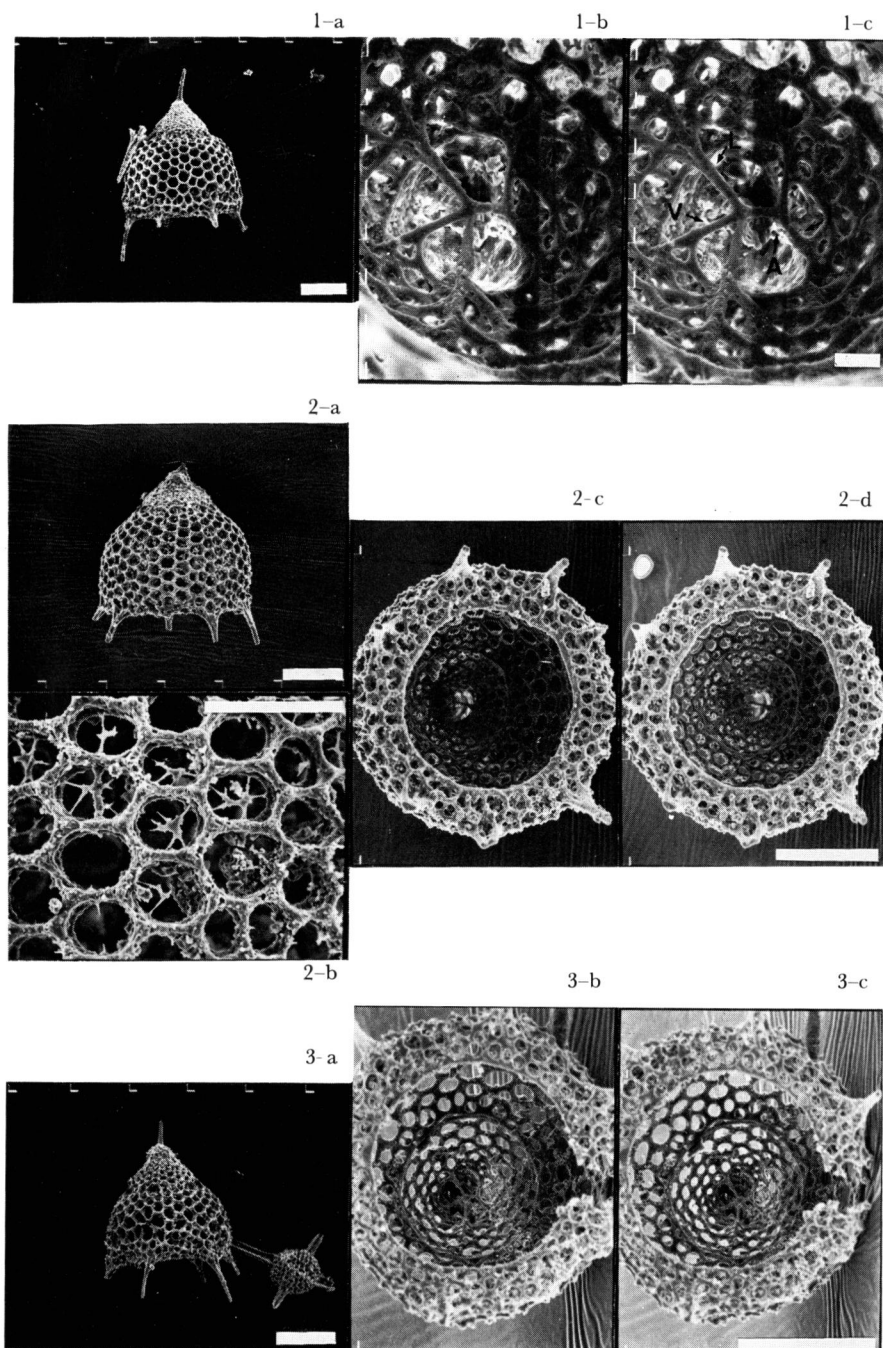

TAKEMURA & NAKASEKO: *Perseus*, a new genus of Jurassic Palaeoscenidiidae