

Title	Present Status of the Nd:YAG Thomson Scattering System Development for Time Evolution Measurement of Plasma Profile on Heliotron J
Author(s)	Minami, Takashi; Arai, Shohei; Kenmochi, Naoki; Yashiro, Hiroaki; Takahashi, Chihiro; Kobayashi, Shinji; Mizuuchi, Tohru; Ohshima, Shinsuke; Yamamoto, Satoshi; Okada, Hiroyuki; Nagasaki, Kazunobu; Nakamura, Yuji; Hanatani, Kiyoshi; Konoshima, Shigeru; Sano, Fumimichi
Citation	Plasma Science and Technology (2013), 15(3): 240-243
Issue Date	2013-03
URL	http://hdl.handle.net/2433/173336
Right	© 2013 IOP Publishing.
Type	Journal Article
Textversion	author

Present Status of the Nd:YAG Thomson Scattering System Development for Time Evolution Measurement of Plasma profile on Heliotron J

Takashi Minami⁽¹⁾, Shohei Arai⁽²⁾, Naoki Kenmochi⁽²⁾, Hiroaki Yashiro⁽²⁾,
Chihiro Takahashi⁽¹⁾, Shinji Kobayashi⁽¹⁾, Tohru Mizuuchi⁽¹⁾, Shinsuke Ohshima⁽³⁾,
Satoshi Yamamoto⁽¹⁾, Hiroyuki Okada⁽¹⁾, Kazunobu Nagasaki⁽¹⁾, Yuji Nakamura⁽¹⁾,
Kiyoshi Hanatani⁽¹⁾, Shigeru Konoshima⁽¹⁾, Fumimichi Sano⁽¹⁾

¹Institute of Advanced Energy, Kyoto University, Gokasho, Uji 611-0011, Japan

²Graduate School of Energy Science, Kyoto University, Gokasho, Uji 611-0011, Japan

³Pioneering Research Unit for Next Generation, Kyoto University, Gokasho, Uji 611-0011,
Japan

E-mail: minami@iae.kyoto-u.ac.jp

Keywords:

plasma diagnostic, Nd:YGA laser Thomson scattering measurement, plasma improved confinement

Abstract

A new high repetition rate Nd:YAG Thomson Scattering system is developed for the Heliotron J helical device. A main purpose of installing the new system is a temporal evolution measurement of a plasma profile for an improved confinement physics such as the edge transport barrier (H-mode) or the internal transport barrier of the helical plasma. The system has 25 spatial points with $\sim 10\text{mm}$ resolution. Two high repetition Nd:YAG lasers ($> 550\text{mJ}@50\text{Hz}$) realize the measurement of the time evolution of the plasma profile with $\sim 10\text{ms}$ time intervals. Scattered light is collected with a large concave mirror ($D = 800\text{mm}$, $f/2.25$) with a solid angle of $\sim 100\text{mstr}$ and transferred to interference filter polychromators by optical fiber bundles in a staircase form. The signal is amplified by newly designed fast preamplifiers with the DC and AC output which reduces the low frequency background noise. The signals are digitized with the Multi-event QDC, fast gated integrators. The data acquisition is performed by the VME-based system which is operated by the CINOS.

1 Introduction

A time evolution measurement of a plasma profile is essential for an investigation of transport physics on magnetic confinement fusion plasma. In fact, the experimental results of the tokamak and helical devices show that the improved confinement phenomena, such as an internal transport barrier or an edge transport barrier (H-mode), are closely related to plasma profile. These results also suggest that the control of the plasma profile can enhance the plasma confinement and the improvement of the fusion plasma performance is also achieved. Moreover, the previous experiments show the improved confinements phenomena accompany by transient phenomena[1]. The plasma profile is rapidly changed on the transition with the fast improvement of the plasma confinement, and the transport characteristics, such as the diffusivity or convection, are changed temporally and spatially. Therefore, in order to investigate the plasma confinement physics, the time evolution of the plasma profile should be measured. Meanwhile, the helical axis Heliotron J device has a merit in the realization of a compact and high beta steady-state reactor. Accordingly, the confinement improvement of the Heliotron J plasma by the plasma profile control is an important issue to realize the fusion reactor of the helical axis Heliotron J configuration[2].

For this purpose, we are developing a new Nd:YAG Thomson scattering system for the Heliotron J device[3], because these method is preferable for the time evolution measurement compared to other 2D thomson scattering methods such as the LIDAR Thomson scattering or TV Thomson scattering system[4, 5, 6, 7].

In this paper, we report the overview of a design, a present status of the construction of the new thomson scattering system of the Heliotron J. Especially, a optical fiber structure of a collection optics, progress of polychromators development, design of preamplifier, and system of data acquisition are described.

2 Overview of the new Nd:YAG Thomson scattering system

Because of the investigation for the improved confinement physics, we determine a goal of the new Nd:YAG Thomson scattering system on Heliotron J plasma (major radius: $R_{ax} = 1.2m$, averaged minor radius: $\langle a \rangle = 0.17m$, plasma volume: $V = 0.7m^3$) as follows:

- Spatial resolution: $\sim 1\text{cm}$
- Spatial channels: 25
- Time intervals of measurement: $\sim 10\text{ms}$
- Range of T_e : $10\text{eV} - 10\text{keV}$
- Range of n_e : $> 0.5 \times 10^{19}\text{m}^{-3}$

Precision of electron temperature and density measurement is important to study a subtle changes of the plasma profiles from one laser pulse to the next. Accordingly, required power of the Nd:YAG laser is greater than 500mJ for the enough precise measurement, because the density of typical Heliotron J plasma is approximately $1 \times 10^{19}\text{m}^{-3}$. It is important to measure at least the temporal evolution of the Heliotron J plasma with a time intervals of 10ms , because the confinement time of the Heliotron J is several millisecond. Consequently, we choose a combination of the two 50Hz Nd:YAG lasers which are made by the Continuum inc., that can produce 500mJ , 10ns laser pulse.

As shown in Fig.1, the laser beam is injected from obliquely outer downward to inner upward side of the Heliotron J, and obliquely backscattered light (scattering angle is 160°) is detected to avoid interference with a coil and a support structure[3]. The laser beams are combined closely together along a common beam path by the mirror and overlapped in the plasma center where they are focussed to a common point.

The beams are transferred to a laser window by the 4 mirrors which are consisted of a high power laser mirror, two-wavelength mirrors, a scan mirror. For beam alignment, a HeNe laser is made collinear with the Nd:YAG lasers, and they are transferred by the two-wavelength mirror by which two different wavelengths (HeNe and Nd:YAG lasers) beams can be reflected. The scan mirror is chosen as the last mirror of the beam transfer system, because the input angle is 35° . Laser input and output windows are located at 1-2 m far from the plasma due to the reduction of stray light reflected by the laser windows. The laser beam path between the laser windows and the vacuum vessel is covered with stainless pipes. A carbon beam dump is installed at outside of the laser output window.

The scattered light is collected with a large concave mirror ($D=800\text{mm}$, $f/2.25$) with a solid angle of $\sim 80 - 100\text{mstr}[3]$. The optical system is optimized for the high transmission and low noise in order to maximize the signal to noise ratio. The collected scattered light is transferred to 25 polychromators by the optical fiber bundles which plugs into the polychromators. As show in Fig.2, each entrance of the fiber bundles are lined up in a staircase pattern. The structure is optimized to reduce loss on a coupling between the fiber and the scattered light from the collected mirror. The main reason of the coupling loss is that the entrance of the optical fiber is partially covered by the next fiber. An aberration on the image is 1- 2.5 mm. A required numerical aperture of the fiber is less than 0.3. Therefore, we choose a polymer clad optical fiber bundle made by the Mitsubishi cable industries LTD ($3\text{mm} \times 1.5\text{mm}$, $NA = 0.39$, number of core wire is 12) for the transformation of the scattered light. The magnification of the image is 0.3-0.4, then the plasma profile is measured with $\sim 10\text{mm}$ resolution, if the 25 measuring points are set on the image.

3 Design of Polychromator, preamplifier and Data Acquisition System

The new polychromators for the Heliotron J consist of interference filters, relay lens, avalanche photodiodes (APD) and fast preamplifier. The Nd:YAG Thomson polychromator has 5 wavelength channels for the scattering light measurement, and one channel for density calibration by the Rayleigh scattering method.

The scattered light is cascaded by the interference filter and the relay lens that is design to adapt to the optical bundle fiber. The APD S8890-30 made by the Hamamatsu photonics K.K. has large area of the detection ($\phi = 3\text{mm}$). The APD gain is increased by the APD bias voltage, which is produced by the high voltage power supply HAPD-0.8PT made by Matsusada Precision K.K. Because the APD gain depends on the temperature, to deduce the thermal variation of the detector, the supplied bias voltage to the APD is controlled using a temperature sensitive diode near the APD package, then the APD gain is regulated.

The transmissivity of the interference filter is $\sim 80\%$. The stray light rejection of the filter is greater than 10^5 . The band path combination of the interference filters are optimized by the performance simulation code over the range of $10\text{eV} - 10\text{keV}$. The results are as follows.

1. Ch.1 (Filter1) : 700-845nm
2. Ch.2 (Filter2) : 845-960nm
3. Ch.3 (Filter3) : 960-1025nm
4. Ch.4 (Filter4) : 1025-1050nm
5. Ch.5 (Filter5) : 1050-1060nm

Fig. 3(a) is the simulated transmissivity of the interference filters that is provided by the filter manufacturer of Materion Co. Error estimations of the polychromator are recalculated by the simulated transmissivity that are chosen as the previous result[3]. In this simulation, the plasma density is assumed to be $3 \times 10^{19} m^{-3}$, which is a typical Heliotron J plasma. At least the two wavelength channel that have enough photon counts to measure the accurate plasma profile exist between $10eV - 10keV$. As is shown in Fig.3(b), the error of the temperature measurement which is caused by the bremsstrahlung is below $\sim 2\%$ from 10eV to 10keV. These results are almost same as the previous simulation.

Each channel of the polychromator has a preamplifier of which schematic diagram is shown in Fig.4. The ADA4817 that is made by Analog Devices, Inc. is chosen as an OP amplifier of the preamplifier. This OP amplifier has low input capacitance ($1.3pF$), low-noise ($4nV/\sqrt{Hz}$), low input bias current ($2pA$), large 3 dB bandwidth ($1050 MHz @ G = 1, RL = 100 \Omega$), and high Slew rate ($870V/\mu s$). The low input impedance is preferable for the short decay time of the signal, because the decay time is approximately determined by the multiplying the input impedance by the resistance of the I-V conversion. The short decay time enable a digitalization to shorten a gate width, then the error from the background light is reduced. The circuit simulation by the SPICE code shows the decay time is less than 80ns as shown in Fig.5, which is faster than the previous preamplifier that is designed for the similar type polychromator[7]. The low input bias current and the low noise characteristics is also important to achieve a higher S/N ratio of the detected signal. The amplifier has the two outputs: one is a direct coupled signal output which is used for calibration and background light measurement that used for an estimation for the statistical error of the detected signal, and another one is the scatter light signal

output which is reduced by the low frequency back ground light using a RC filter. The signals are digitized with CAEN V792 32 Channel Multi-event QDC, fast gated integrators. The gate signal is produced from a sample of the laser pulse to minimize jitter.

A real-time VME computer system is used for a data acquisition system. The system is constructed on a VME bus operating of which throughput is 30Mbyte/Sec. CPUs are Motorola 68060 with 60MHz clock rate. The system is operated by the CINOS(CHS Integrated No Operation System) [9], which was first developed for CHS data acquisition system. The CINOS is not a multi-task operating system, but a system software that perform a time invariant data acquisition without the OS. The acquired data are transfer to LINUX computer by LAN. The data are analyzed immediately following a plasma discharge by the computer for the data analysis.

4 Summary

We have described the design and present status of the new Nd:YAG Thomson scattering system which is developed on the heliotron J for the study of the improved confinement physics. Two high repetition Nd:YAG lasers ($> 550mJ@50Hz$) realize the measurement of the time evolution of the plasma profile with $\sim 10ms$ time intervals. The obliquely back scattered light is detected using the large concave mirror (D=800mm) and the optical fiber bundles in the staircase pattern. The system has 25 spatial points with $\sim 10mm$ resolution. The 25 interference filter polychromators measures scattered spectra which detected by the APD. The signal is amplified by the fast OP amplifier with the DC for the background light and the AC output for the scattered light from the pulsed laser. The signals are digitized with the Multi-event QDC, fast gated integrators. The data acquisition is performed by the VME-based system which is operated by the CINOS. The goal of the measurable electron temperature range is from 10eV to 10keV and the minimum detectable density is approximately $5 \times 10^{18}m^{-3}$. The predicted error from the bremsstrahlung is below $\sim 2\%$ for the electron temperature measurement and below $\sim 3\%$ for the electron density measurement.

Acknowledgments

This work is strongly supported by the Collaboration Program of the Laboratory for Complex Energy Processes, IAE, Kyoto University and the NIFS Collaborative Research Program

(NIFS10KUHL030, NIFS09KUHL028, NIFS10KUHL033).

References

- [1] A. Fujisawa, H. Iguchi, H. Idei, S. Kubo, K. Matsuoka, S. Okamura, K. Tanaka, T. Minami, et al, Phys.Rev.Lett. 81(11) (1998) p.2256-2259
- [2] T. Obiki, T. Mizuuchi, K. Nagasaki, H. Okada, F. Sano, K. Hanatani, Y. Liu, T. Hamada, et al, Nuclear Fusion, Vol. 41, No. 7 (2001) p833-p844
- [3] T.Minami, S.Kobayashi, T.Mizuuchi, H.Yashiro, M.Takeuchi, S.Ohshima, et.el., Rev.Sci.Instrum. **81**, 10D532 (2010)
- [4] H. Salzmann, J. Bundgaard, A. Gadd, C.Gowers, K.B.Hansen, K.Hirsch, P.Nielsen, et.al. Rev. Sci. Instrum. 59, 1451 (1988)
- [5] N.Bretz, D.Dimock, V.Foote, D. Johnson, D. Long, E. Tolnas, Applied Optics Vol.17, No.2 (1978) p.192-202
- [6] H. Murmann, S. Götsch, H. Röhr, H. Salzmann, K. H. Steuer. Rev. Sci. Instrum. 63, 4941 (1992)
- [7] T.N.Carlstrom, G.L.Campbell, J.C.Deboo, R. Evanko, J. Evans, C. M. Greenfield, J. Haskovec, C. L. Hsieh, E. McKee, et.al. Rev. Sci. Instrum. 63, 4901 (1992)
- [8] T.Minami, A. Fujisawa, H. Iguchi, Y. Liang, K. Ida, S. Nishimura, M. Yokoyama, S. Murakami, et.al. Nuclear Fusion, volume 44, issue 2, (2004) p342-349
- [9] C. Takahashi et al: About timing critical signal processing. Kyoto University technique collegium (2009)

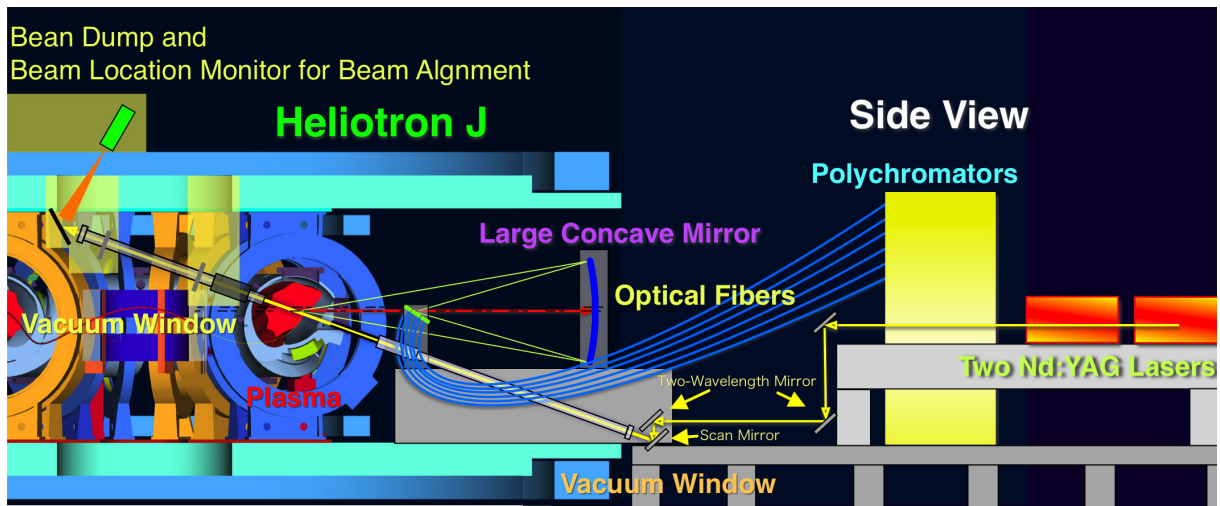

Figure 1: Schematic diagram of Nd:YAG Thomson scattering system on Heliotron J

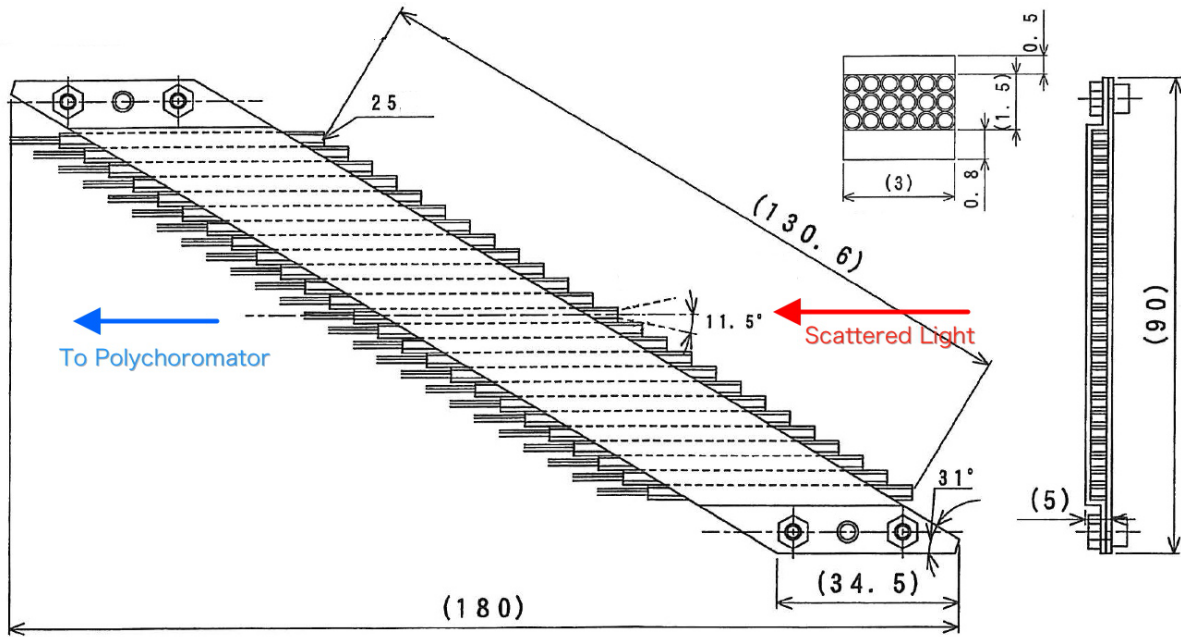

Figure 2: Schematic of optical fiber bundle in stair case form for collective system

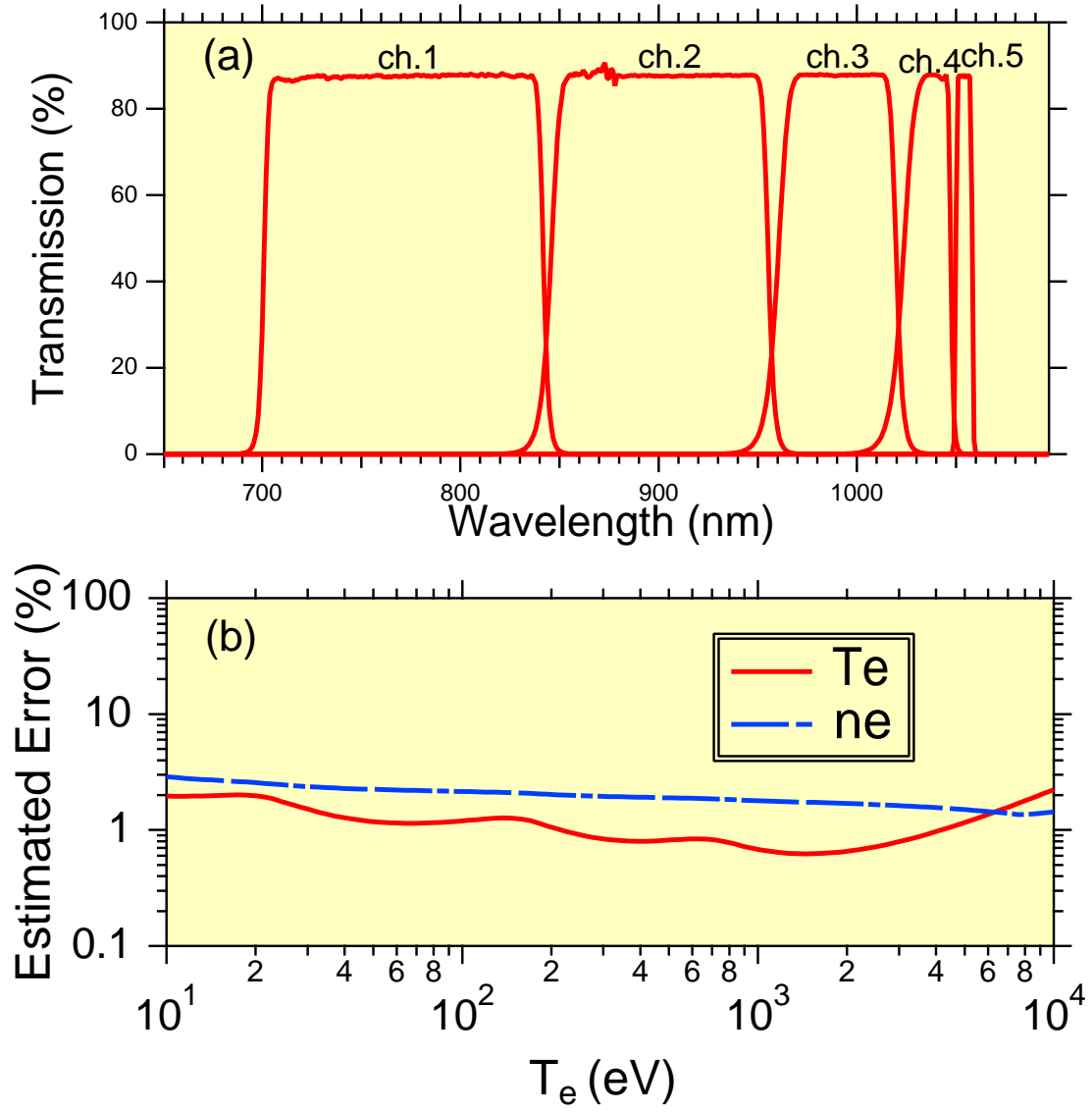

Figure 3: Simulated filter transmission curves and estimated error from polychromator for T_e, n_e

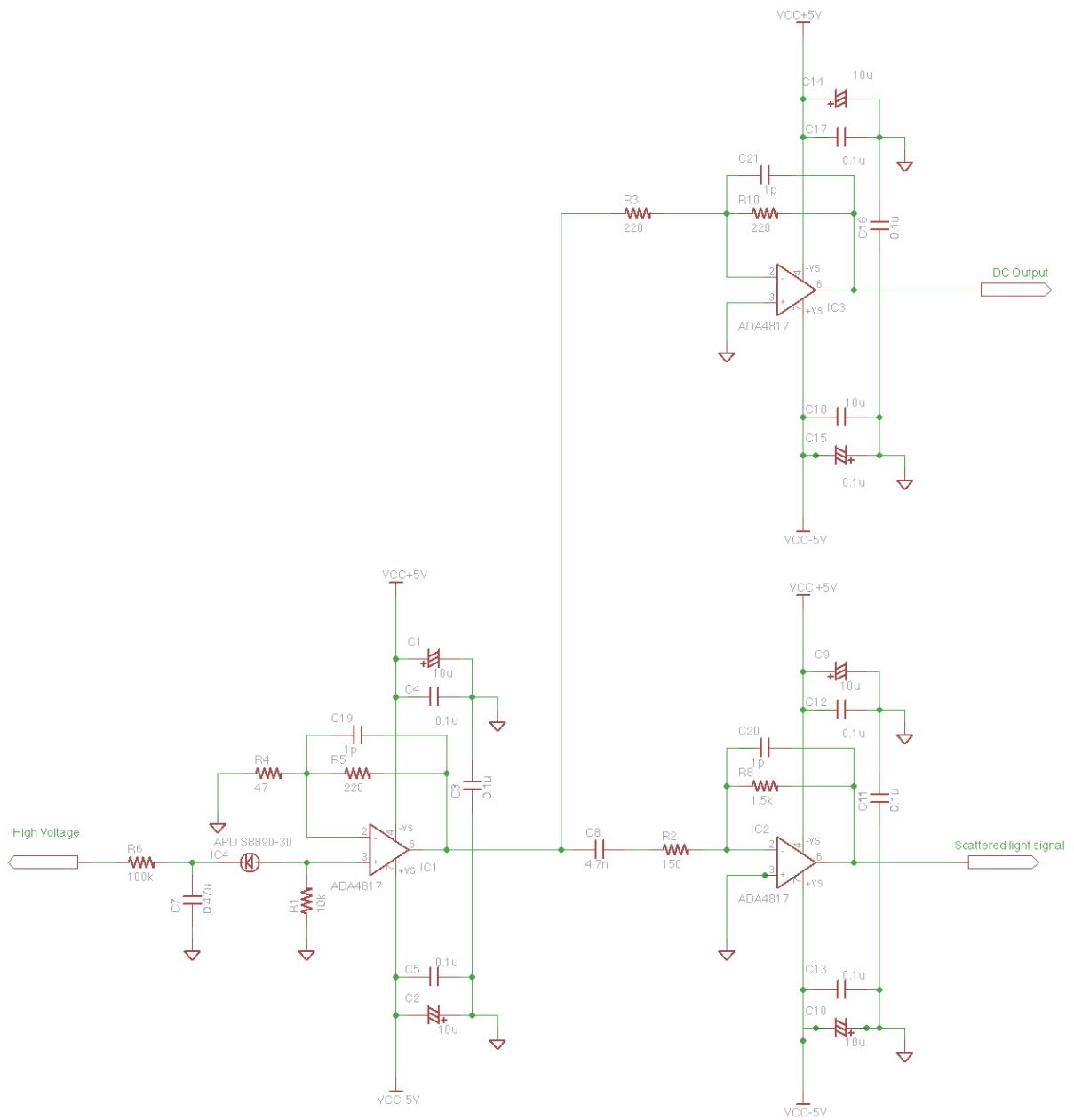

Figure 4: Circuit diagram of APD preamplifier for polychromator

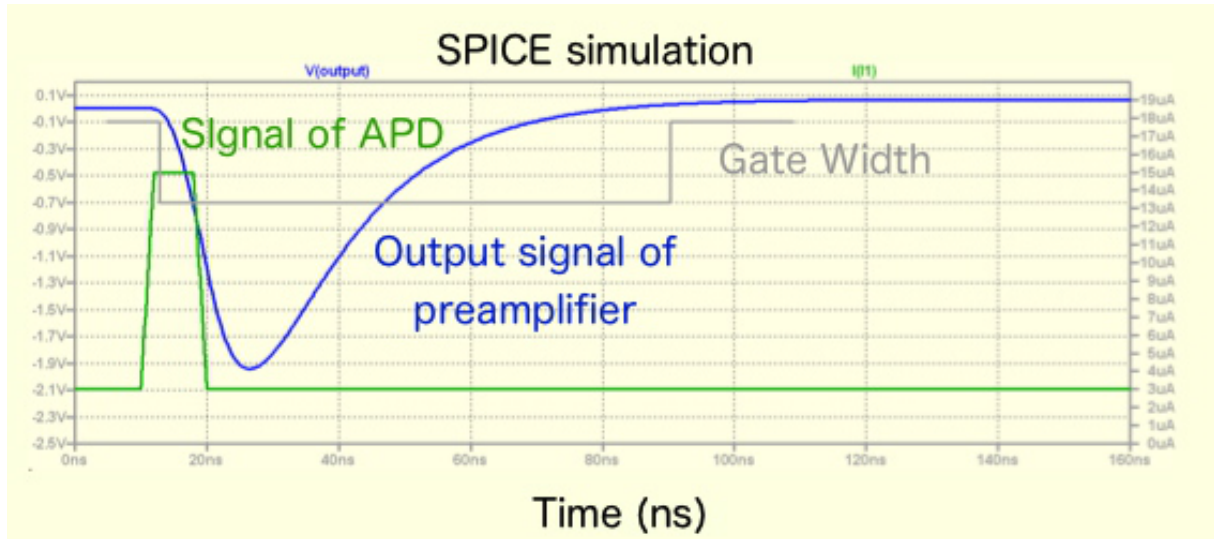

Figure 5: Simulation of response for APD preamplifier by SPICE. Detector current, amplifier red signal, and gate width are shown.