

Title	Implantable pneumatically actuated microsystem for renal pressure-mediated transfection in mice.
Author(s)	Shimizu, Kazunori; Kawakami, Shigeru; Hayashi, Kouji; Mori, Yuki; Hashida, Mitsuru; Konishi, Satoshi
Citation	Journal of controlled release : official journal of the Controlled Release Society (2012), 159(1): 85-91
Issue Date	2012-04-10
URL	<a href="http://hdl.handle.net/2433/155489">http://hdl.handle.net/2433/155489</a>
Right	© 2012 Elsevier B.V.
Type	Journal Article
Textversion	author

# Implantable Pneumatically Actuated Microsystem for Renal Pressure-Mediated Transfection in Mice

Kazunori Shimizu<sup>a,b,\*</sup>, Shigeru Kawakami<sup>c</sup>, Kouji Hayashi<sup>c</sup>, Yuki Mori<sup>d</sup>, Mitsuru Hashida<sup>a,c,e</sup>, Satoshi Konishi<sup>a,b,d,\*</sup>

<sup>a</sup> Institute for Innovative NanoBio Drug Discovery and Development, Graduate School of Pharmaceutical Sciences, Kyoto University, Sakyo-ku, Kyoto 606-8501, Japan

<sup>b</sup> Ritsumeikan-Global Innovation Research Organization, Ritsumeikan University, Noji-higashi, Kusatsu, Shiga 525-8577, Japan

<sup>c</sup> Department of Drug Delivery Research, Graduate School of Pharmaceutical Sciences, Kyoto University, Sakyo-ku, Kyoto 606-8501, Japan

<sup>d</sup> Department of Micro System Technology, Ritsumeikan University, Noji-higashi, Kusatsu, Shiga 525-8577, Japan

<sup>e</sup> Institute for Integrated Cell-Material Sciences, Kyoto University, Kyoto 606-8302, Japan

*\*Corresponding author. Tel.: +81-77-561-2554; fax: +81-77-561-2665.*

*E-mail: kshimizu@pharm.kyoto-u.ac.jp (K.Shimizu), konishi@se.ritsumei.ac.jp (S.Konishi)*

## **Abstract**

*In vivo* transfection is an important technique used in biological research and drug therapy development. Previously, we developed a renal pressure-mediated transfection method performed by pressing a kidney after an intravenous injection of naked nucleic acids. Although this is a useful method because of its safety and wide range of applications, an innovative approach for performing this method without repeatedly cutting open the abdomen is required. In this study, we developed an implantable microsystem fabricated by Micro-Electro-Mechanical Systems (MEMS) technologies for renal pressure-mediated transfection. The system consists of a polydimethylsiloxane pneumatic balloon actuator (PBA) used as an actuator to press the target kidney. The PBA of the implanted microsystem can be actuated without opening the abdomen by applying air pressure from outside the body to the pressure-supplying port via a needle. We successfully performed renal pressure-mediated transfection using the newly developed system when the implanted system was activated at 60 kPa for 10 s. This is the first report of an implantable MEMS-based microsystem that demonstrates *in vivo* transfection to a kidney using naked plasmid DNA.

**Keywords:** Drug delivery, Gene transfer, Micromachining, Silicone elastomer

An implantable MEMS-based microsystem was developed for *in vivo* transfection to the kidneys using naked plasmid DNA in mice.

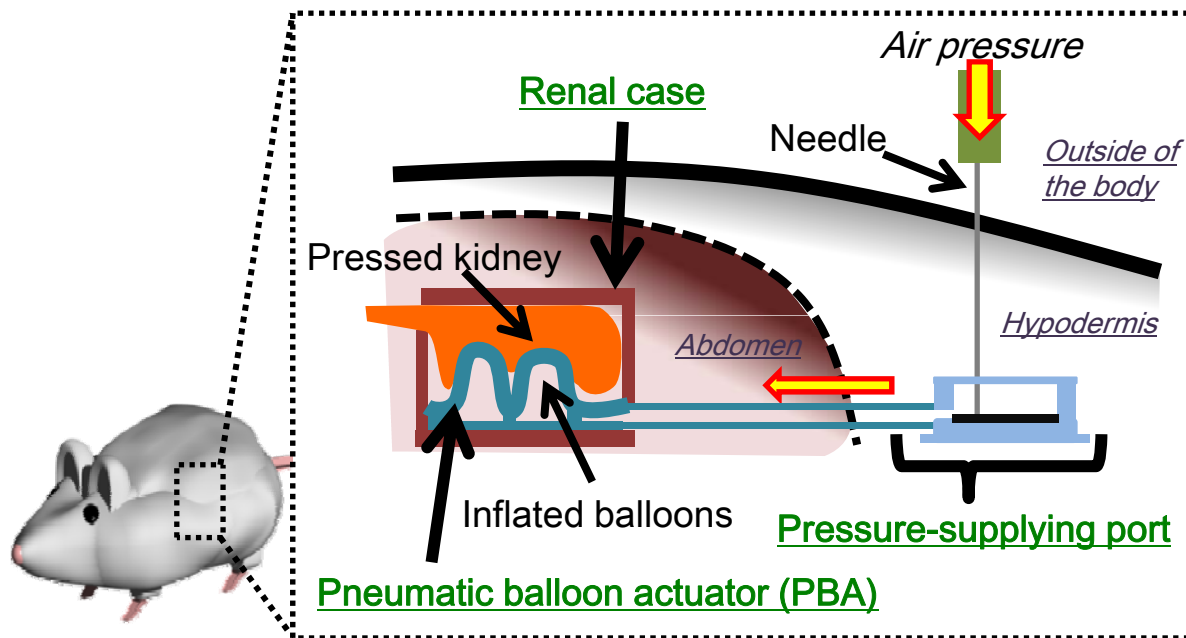

Renal pressure-mediated transfection using the implanted microsystem

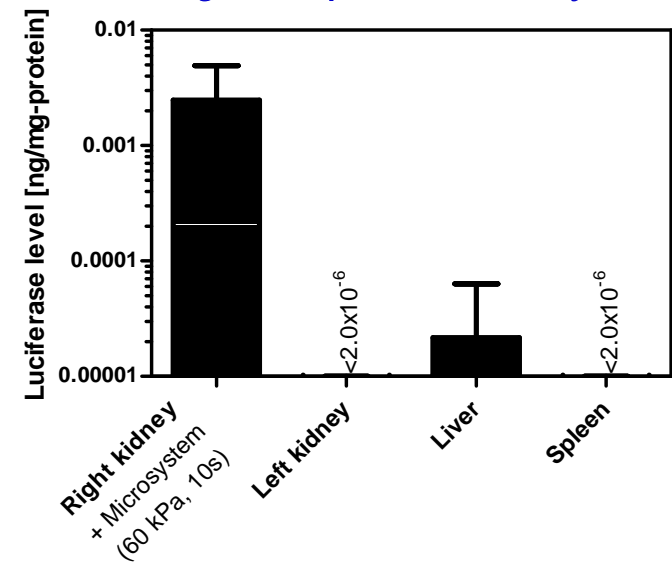

## 1. Introduction

*In vivo* transfection of nucleic acids is one of the most important techniques used in biological research, diseased animal development, and clinical treatment. Its application in laboratory animals, including mice, is also very important, especially for *in vivo* functional analyses of genes of unknown functions as well as preclinical studies of human gene therapies. Although various recombinant viral vectors and nonviral carriers such as cationic liposomes and polymers have been reported, they might have some issues that are causes for concern, such as toxicity [1-3]. On the other hand, the naked nucleic acid transfection method has been considered the simplest and safest method because of its convenient preparation and handling as well as its lack of toxicity associated with cationic carriers [4].

As established by the seminal study of Liu et al. [5], non-invasive gene delivery to the liver can be achieved by a mechanical massage around the abdomen after intravenous administration of naked pDNA in mice. Previously, our group reported that this phenomenon could also be applied to the transfection induced by direct pressure to the kidneys, spleen, and liver [6, 7]. Although the kidneys are important organs in biomedical research and nucleic acid treatment, renal transfection methods have not been well documented. We and another group reported that the renal pressure-mediated transfection method could be applied to siRNA [6] and micro-RNA [8]. We successfully controlled and quantified the magnitude of pressure on the spleen and kidneys and found that 0.59 N/cm<sup>2</sup> was sufficient for efficient transfection in mice [7]. We also confirmed that this method could transfect naked plasmid DNA to the kidneys without renal dysfunction [6] and did not induce the secretion of proinflammatory cytokines such as TNF- $\alpha$ , IL-6, IL-12, and INF- $\gamma$  [7].

The expression of nucleic acids that were transfected using the pressure-mediated transfection method disappeared within a week [9]. To use the *in vivo* transfection method in clinical applications (e.g., *in vivo* gene functional analysis, diseased animal development, and preclinical studies of gene therapies), transgene expression levels are needed to be maintained at the desired levels for a longer period. One promising strategy involves the repeated application of the renal pressure-mediated transfection method with appropriate timing. However, repeated application to the kidneys is not easy because the abdomen of a mouse must be cut open every time, which will cause severe damage or toxicity to the mouse. Therefore, an innovative technology is needed to perform the renal pressure-mediated transfection method without repeatedly cutting open the abdomen to maintain the gene expression.

Polydimethylsiloxane (PDMS) is one of the silicone-based organic polymers widely used as a material for bio-microdevices and microfluidic chips [10-17] because of its ease of fabrication, high biocompatibility, high chemical inertness, high gas permeability, transparency in the UV-visible regions, low electrical conductivity, and elasticity. We have proposed an all PDMS pneumatic balloon actuator (PBA) as a soft or flexible microactuator [18, 19]. The PBA consists of 2 thin PDMS layers that are bonded irreversibly; one of them has a micropattern for channels and balloons that are made by a molding process based on Micro-Electro-Mechanical Systems (MEMS) technologies. When pressure is applied to the inlet of the channel, the balloons of the PBA inflate in response, and the PBA subsequently actuates. The motion of the PBA can be controlled by the composition or thickness of the PDMS layers as well as the micropattern designs [19]. Thus far, we have applied the PBA for various biomedical applications, for example, as a tool for cell sheet transplantation to the eyeball [20], a tool for functional electrical nerve stimulation [21], a pneumatic peristaltic pump for a lab-on-a-chip [22], and a gradation generator for *in vitro* cell stretching culture [23]. Thus, the PBA has great potential for various biomedical applications.

The present study aimed to perform the tissue pressure-mediated transfection method without repeatedly cutting open the abdomen. To do so, we developed an implantable

pneumatically actuated microsystem in which a PBA was used as an actuator to press the target tissue for tissue pressure-mediated transfection in mice (Fig. 1).

## 2. Materials and methods

### 2.1. Plasmid DNA

The cytomegalovirus (CMV) immediate-early promoter-driven plasmid encoding complementary luciferase DNA (pCMV-Luc) was used [24]. The amplification, isolation, and purification of pCMV-Luc were performed as described previously [24].

### 2.2. Animals

ICR mice (female, 5 weeks old) were purchased from Japan SLC Inc. (Shizuoka, Japan). All animal experiments were carried out in accordance with the Guide for the Care and Use of Laboratory Animals as adopted and promulgated by the U.S. National Institutes of Health (Bethesda, MD) and the Guideline for Animal Experiments of Kyoto University (Kyoto, Japan).

### 2.3. Design and fabrication of renal cases

The renal case was designed by 3D CAD software (Solid Edge; Siemens PLM Software, Munich, Germany) and fabricated by a 3-dimensional printing system (Objet Geometries Ltd., Rehovot, Israel) according to the manufacturer's instructions (Fig. 2). The case consists of a main part and 2 lids (Fig. 2a). The rear wall of a main part has a  $5 \times 2$  mm square hole for threading the PBA. The 1<sup>st</sup> lid has 2 square holes ( $2 \times 1.5$  mm), and the 2<sup>nd</sup> lid has 1 square hole ( $2 \times 2$  mm) for easy handling with tweezers. The 3 parts are 1 mm thick. After assembling the 3 parts, the inner size of the case is 6 mm wide, 12 mm long, and 6 mm high (Fig. 2b). The assembled case has a 2-mm gap between the main part and the 1<sup>st</sup> lid that was designed to avoid clamping both vessels along with a ureter (white arrow heads; Fig. 2b).

### 2.4. Design and fabrication of the PBA

The design and fabrication process of PBA is shown in Fig. 3. To press the encased kidney, the volume of the PBA with inflated balloons needs to become larger than the volume of the space between the renal case and kidney. Considering the volume of the interspace, a PBA with 8 balloons ( $4 \times 3$  mm each) was designed with each balloon connected by air channels (Fig. 3a). The widths of the channels are 200  $\mu$ m. The PBA was fabricated by a simple batch process of PDMS molding technology as described previously with some modifications (Fig. 3b) [19]. Briefly, micropatterns were made by an SU-8 3050 photo-resist (MicroChem, Corp., Newton, MA) by a photolithography technique on a Si wafer. PDMS (10:1) solution was spin-coated on the micropatterns and a flat wafer at 500 rpm for 30 s and cured at 75°C for 2 h. The surfaces of these thin PDMS layers were treated by VUV (MEXSY0017BH; Ushio Inc., Tokyo, Japan) for 90 s and bonded to each other irreversibly. The PBA was approximately 500  $\mu$ m thick. To form an air inlet, a small block of PDMS was bonded to the PBA, a hole was punched out using a disposable biopsy punch (1 mm diameter; Kai industries Co., Ltd., Gifu, Japan), and the bottom side of the hole was

sealed with tape. A mouse vascular access port (MICP-PU-C10; Instech Solomon, Plymouth Meeting, PA, USA) was employed as a pressure-supplying port. To increase the strength of the port against the air pressure, a part of the port was covered with adhesive (Super-X; Cemedine, Tokyo, Japan). The pressure-supplying port and the air inlet were connected by a silicon tube with an outer diameter of 1 mm, and the connection was sealed with PDMS.

### *2.5. Pneumatic pressure-regulating system*

Regulated air pressure was supplied by the system that we developed previously [23]. Briefly, the pneumatic pressure-regulating system consists of electro-pneumatic regulators (SMC Corporation, Tokyo, Japan) and a mini air compressor (AC-500; Too Marker Products, Tokyo, Japan) that was used to supply the controlled amount of air pressure (Fig. 4). The air pressure was measured by a pressure transducer (PGM-5KH; Kyowa, Tokyo, Japan) and an instrumentation amplifier (DPM-911A, Kyowa).

### *2.6. Measurement of blood urea nitrogen (BUN) level*

BUN level was measured using commercially available assay kit (Wako Pure Chemicals Industries, Ltd., Osaka, Japan) as described previously [6]. Briefly, a mouse was anesthetized and the right kidney was exposed by a midline incision. The right kidney was encased in a renal case and the abdomen was closed. The blood was collected from the inferior vena cava of the mice at 3, 5, and 7 days after encasing. The blood was incubated for 1 h at room temperature and overnight at 4°C. Then, the serum was isolated by centrifugation. The mice treated with 5 mg/kg of cisplatin were used as a positive control [25].

### *2.7. Investigation of the effects of pressure conditions on gene expression level*

The effects of different pressure conditions on gene expression levels were investigated using the renal press microsystem except for a pressure-supplying port. A mouse was anesthetized with isoflurane and maintained on anesthetic during treatment. The right kidney was exposed by a midline incision and was encased in a renal case with a PBA, and 100 µg pCMV-LUC in 200 µL saline was injected intravenously. Then, the regulated air pressure was supplied to the PBA via a silicon tube under several different conditions: 30, 45, 60, 75, and 90 kPa for 3, 10, or 20 s. The microsystem was removed from the abdomen after the pressure was shut off, and the abdomen was closed. Gene expression levels were determined by luciferase assay after 6 h of applying air pressure as described previously [24].

### *2.8. Transfection in mouse kidney using the implanted microsystem*

Mice were anesthetized with isoflurane and maintained on anesthetic during the implantation of the renal press microsystem. The right kidney was exposed by a midline incision and encased in a renal case with a PBA. A pressure-supplying port was fixed to the abdominal wall with 1 suture, and the abdominal wall and skin were subsequently sutured. Two days after of the implantation, pCMV-LUC was transfected into the mouse kidney using the microsystem. pCMV-LUC (100 µg in 200 µL saline) was injected intravenously into the mice, and air pressure was then

supplied to the implanted microsystem by using the pneumatic pressure-regulating system via the pressure-supplying port and a needle. Gene expression levels were determined by luciferase assay after 6 h of applying air pressure as described previously [24].

### 2.9. Statistical analysis

Prism 5 software (Graphpad Software, La Jolla, CA, USA) was used. Statistical significance was determined using unpaired *t* test for two groups. ANOVA was performed for multiple comparisons among different groups, followed by the Bonferroni test.

## 3. Results

We developed an implantable microsystem for the renal pressure-mediated transfection method in mice (Fig. 1). The system consists of a PBA, renal case, and pressure-supplying port. The target kidney and the PBA were inserted into the renal case, and the balloons of the PBA were inflated by the air pressure supplied from outside the body by a needle via a pressure-supplying port.

### 3.1. Encasing mouse kidney in a renal case

The case was composed of 3 parts (Fig. 2a) that were assembled into a rectangular parallelepiped shape (Fig. 2b). Fig. 5a shows the process of kidney encasing; a kidney phantom made of polyvinyl alcohol was used for a demonstration. First, the main part was slid under the kidney (Fig. 5a-i). Then, the 1<sup>st</sup> lid was slid into the main part in a descending manner (Fig. 5a-ii). To avoid clamping both blood vessels along with a ureter, a 2-mm gap was designed between the main part and the 1<sup>st</sup> lid. Finally, the 2<sup>nd</sup> lid was slid into main part in a lateral manner (Fig. 5a-iii). The 2<sup>nd</sup> lid was designed to cover the top of the 1<sup>st</sup> lid to fix it. As shown in Fig. 5b, a real mouse kidney was successfully encased by the same process. BUN level, one of the indicators of renal functions, did not increase by encasing the kidney by the renal case (Fig. 5c).

### 3.2. Activation of the PBA

Fig. 6a shows a PBA with 8 balloons connected to a pressure-supplying port. The balloons of the PBA inflate in response to the air pressure supplied from the needle. When the air pressure was applied, all balloons of the PBA started to inflate with similar timing (Fig. 6b). When the balloons of the PBA were maximally inflated (just before bursting, about 70 kPa), the volume of the PBA was approximately 286.5 mm<sup>3</sup>, whereas the original volume of the PBA was approximately 126.5 mm<sup>3</sup> (i.e., a 230% increase). The PBA was encased in the renal case, and the activation of the PBA in the case was observed (Fig. 6c and Movie 1). It was confirmed that the case did not prevent the inflation of balloons. Next, the PBA was encased in the renal case with the kidney phantom. We confirmed that the kidney phantom was pressed by the PBA with the inflated balloons when air pressure was supplied to the port (Movie 2).

### 3.3. Effects of pressure condition on gene expression level



To produce high transfection efficiency, the optimal conditions of the actuation of the developed microsystem was examined (Fig. 7). Right murine kidneys were equipped with the microsystem, 100  $\mu\text{g}$  pCMV-Luc was intravenously injected, air pressure was applied to the microsystem, and the system was removed. The luciferase levels were measured 6 h after the injection of pCMV-Luc. First, the effect of duration (0, 3, 10, and 20 s) of the air pressure on the luciferase expression levels was examined. As shown in Fig. 7a, the highest level (approximately 0.024 ng/mg protein) was obtained when the air pressure was applied for 10 s. Then, the effect of different pressures (0, 30, 45, 60, 75, and 90 kPa) was examined. When the pressure was applied at 90 kPa, the encased kidney sometimes slipped out of the renal case. Although the luciferase level increased with the increase in the amount of the air pressure, it retained a similarly high level between 60 and 75 kPa (Fig. 7b). Therefore, we performed the subsequent experiments with the optimized conditions of 60 kPa for 10 s.

### 3.4. Transfection of plasmid DNA using the implanted microsystem

Fig. 8a shows an anesthetized mouse just after implantation of the microsystem. The pressure-supplying port was implanted under the skin (arrow in Fig. 8a). After 2 days of implantation, 100  $\mu\text{g}$  pCMV-Luc was injected intravenously and the microsystem was actuated using the optimized condition (60 kPa for 10 s). Since the tissue pressure-mediated transfection method was able to apply to kidneys, liver, and spleen [7], the luciferase expression levels in them were measured 6 h after the actuation. The luciferase level in the microsystem-equipped kidney (right kidney) was approximately 0.0025 ng/mg protein (Fig. 8b). In contrast, the level in the liver was approximately 0.000022 ng/mg protein and that in the left kidney and the spleen were less than  $2.0 \times 10^{-6}$  ng/mg protein. These results suggest that the implanted microsystem could apply the renal pressure-mediated transfection without the need to cut open the abdomen in mice.

## 4. Discussion

Recently, MEMS technologies have been applied in drug delivery system (DDS) [26]. MEMS-based drug delivery devices have the potential to completely control drug release and be implanted in small spaces inside the body [27, 28]. Such applications include implantable DDS microdevices with a multidrug reservoir for polypeptide delivery [29], an electrolysis-actuated pump for ocular diseases [30], a piezoelectrically actuated silicon valve for chronic pain [31], frequency-controlled wireless hydrogel microvalves [32], and a microsuction device with a DDS micropump [33]. The present study represents our initial effort to create a MEMS-based gene transfection device with a pneumatic actuator for targeted transfection into the kidneys (Fig. 1). Our microsystem fabricated by a MEMS batch process was small enough to be implanted into mice and inexpensive enough to be disposable. Since all PDMS PBAs fabricated by MEMS technologies are soft and deformable, it was realized that they could press the kidneys safely and precisely (Fig. 6). As far as we know, this is the first report of an implantable MEMS-based microsystem demonstrating *in vivo* transfection to the kidneys using naked plasmid DNA in mice.

In the previous study, a syringe-modified pressure controlling device was used to perform the renal pressure-mediated transfection method [7]. The abdomen of a mouse must be cut open every experiment for the repeated application to the kidneys by using this device. In contrast, the implantable pneumatically actuated microsystem that we developed in the present study enables us to perform the renal pressure-mediated transfection method without repeatedly cutting open the abdomen (Fig. 8). Thus, we succeeded to develop an innovative technology for repeated application of the renal pressure-mediated transfection method. However, the transgene expression level using

the implantable system was considerable lower than that using the previous syringe-like device [7] and the expression level may not be enough for the practical use. We believe that the system still has room for improvement in its design to achieve high-efficiency transfection in mice. In the present study, the highest luciferase level (0.024 ng/mg protein) was obtained in the pressed kidney specifically when the temporarily implanted microsystem was activated at 60 kPa for 10 s. When the completely implanted microsystem was activated at the same condition, the luciferase level was approximately 0.0025 ng/mg protein in the microsystem-equipped kidney. Meanwhile, 5 ng/mg luciferase protein was achieved in the pressed kidney at 0.59 N/cm<sup>2</sup> (5.9 kPa) for 1 s by using the previous device [7]. Thus, although the applied air pressure in the present study was approximately 10 times greater than that in previous studies, the luciferase levels achieved in the present study was 200 or 2000 times smaller than previously reported values (Fig. 7 and 8b). This discrepancy may be explained that the efficient luciferase expression is induced by the deforming extent as well as the pressing of the kidney. Thus, further development of our microsystem that can be transiently deforming the kidney might enable us to achieve high transfection efficacy in mice. Besides, as shown in Fig. 8b, the luciferase expression was detected slightly in the liver. Probably, the renal case encasing the right kidney sometimes happened to apply small pressure to the liver, which is located just above the right kidney. Therefore, it may be needed to modify the design of the renal case for the improvement of the tissue selectivity of our microsystem.

The toxicities of the developed microsystem against mice must be considered in order to use the microsystem for long-term applications in mice. We considered the toxicities from 2 different perspectives. The first is the toxicity that may be caused by the materials of the microsystem itself. The microsystem was implanted into mice (the kidney was not encased in the renal case), and we confirmed that the mice were able to be kept alive for more than 3 months (n = 4), suggesting that little severe toxicity is induced by the materials of the microsystem such as PDMS and the photo-curable polymer. The second is the toxicity against kidney function that results from encasing the kidney in the renal case. BUN levels of the mice of which right kidneys were encased in the renal cases was measured. As shown in Fig. 5c, the BUN levels of the mice with the case did not increase within 7 days of encasement. Also, in our preliminary experiment, histological observation of encased kidneys was performed after 90 days of encasement. There were no apparent morphological differences between kidneys inside and outside cases. Therefore, these results suggest that the microsystem can be administered in mice for long periods without severe damage although further additional experiments confirming this are needed.

In conclusion, we developed a MEMS-based implantable microsystem for *in vivo* transfection into murine kidneys. The implantable microsystem contains a PBA as a small, soft, and safe actuator. The kidneys were pressed and the renal pressure-mediated transfection without repeatedly cutting open the abdomen to maintain the gene expression was successful. The information obtained may be valuable for the development of new therapeutic methods for renal refractory diseases using microsystem by *in vivo* gene functional analysis, diseased animal development, and preclinical studies of gene therapies.

## Acknowledgements

We would like to thank Takahiro Yamasaki, Atsushi Shunori, and Haruyuki Takahashi for their technical assistance. This study was partly supported by a grant from Ritsumeikan Global Innovation Research Organization (R-GIRO).

## References

- [1] S. Kawakami, Y. Ito, P. Charoensit, F. Yamashita, M. Hashida, Evaluation of proinflammatory cytokine production induced by linear and branched polyethylenimine/plasmid DNA complexes in mice, *Journal of Pharmacology and Experimental Therapeutics*, 317 (2006) 1382-1390.
- [2] J.D. Tousignant, A.L. Gates, L.A. Ingram, C.L. Johnson, J.B. Nietupski, S.H. Cheng, S.J. Eastman, R.K. Scheule, Comprehensive analysis of the acute toxicities induced by systemic administration of cationic lipid: Plasmid DNA complexes in mice, *Human Gene Therapy*, 11 (2000) 2493-2513.
- [3] C.S. Manno, V.R. Arruda, G.F. Pierce, B. Glader, M. Ragni, J. Rasko, M.C. Ozelo, K. Hoots, P. Blatt, B. Konkle, M. Dake, R. Kaye, M. Razavi, A. Zajko, J. Zehnder, H. Nakai, A. Chew, D. Leonard, J.F. Wright, R.R. Lessard, J.M. Sommer, M. Tigges, D. Sabatino, A. Luk, H. Jiang, F. Mingozzi, L. Couto, H.C. Ertl, K.A. High, M.A. Kay, Successful transduction of liver in hemophilia by AAV-Factor IX and limitations imposed by the host immune response, *Nat Med*, 12 (2006) 342-347.
- [4] H. Herweijer, J.A. Wolff, Progress and prospects: naked DNA gene transfer and therapy, *Gene Ther.*, 10 (2003) 453-458.
- [5] F. Liu, L. Huang, Noninvasive gene delivery to the liver by mechanical massage, *Hepatology*, 35 (2002) 1314-1319.
- [6] H. Mukai, S. Kawakami, M. Hashida, Renal press-mediated transfection method for plasmid DNA and siRNA to the kidney, *Biochemical and Biophysical Research Communications*, 372 (2008) 383-387.
- [7] H. Mukai, S. Kawakami, Y. Kamiya, F. Ma, H. Takahashi, K. Satake, K. Terao, H. Kotera, F. Yamashita, M. Hashida, Pressure-Mediated Transfection of Murine Spleen and Liver, *Human Gene Therapy*, 20 (2009) 1157-1167.
- [8] S. Oba, S. Kumano, E. Suzuki, H. Nishimatsu, M. Takahashi, H. Takamori, M. Kasuya, Y. Ogawa, K. Sato, K. Kimura, Y. Homma, Y. Hirata, T. Fujita, miR-200b Precursor Can Ameliorate Renal Tubulointerstitial Fibrosis, *PLoS ONE*, 5 (2010) e13614.
- [9] H. Mukai, S. Kawakami, H. Takahashi, K. Satake, F. Yamashita, M. Hashida, Key Physiological Phenomena Governing Transgene Expression Based on Tissue Pressure-Mediated Transfection in Mice, *Biol Pharm Bull*, 33 (2010) 1627-1632.
- [10] M.M. Stevens, M. Mayer, D.G. Anderson, D.B. Weibel, G.M. Whitesides, R. Langer, Direct patterning of mammalian cells onto porous tissue engineering substrates using agarose stamps, *Biomaterials*, 26 (2005) 7636-7641.
- [11] H.C. Fan, J. Wang, A. Potanina, S.R. Quake, Whole-genome molecular haplotyping of single cells, *Nat Biotech*, 29 (2011) 51-57.
- [12] S. Takayama, E. Ostuni, P. LeDuc, K. Naruse, D.E. Ingber, G.M. Whitesides, Laminar flows - Subcellular positioning of small molecules, *Nature*, 411 (2001) 1016-1016.
- [13] K. Shimizu, H. Fujita, E. Nagamori, Micropatterning of single myotubes on a thermoresponsive culture surface using elastic stencil membranes for single-cell analysis, *Journal of Bioscience and Bioengineering*, 109 (2010) 174-178.
- [14] H. Matsui, T. Osada, Y. Moroshita, M. Sekijima, T. Fujii, S. Takeuchi, Y. Sakai, Rapid and enhanced repolarization in sandwich-cultured hepatocytes on an oxygen-permeable membrane, *Biochemical Engineering Journal*, 52 (2010) 255-262.
- [15] N.J. Sniadecki, A. Anguelouch, M.T. Yang, C.M. Lamb, Z. Liu, S.B. Kirschner, Y. Liu, D.H. Reich, C.S. Chen, Magnetic microposts as an approach to apply forces to living cells, *Proc. Natl. Acad. Sci. U. S. A.*, 104 (2007) 14553-14558.
- [16] A.W. Feinberg, A. Feigel, S.S. Shevkoplyas, S. Sheehy, G.M. Whitesides, K.K. Parker, Muscular thin films for building actuators and powering devices, *Science*, 317 (2007) 1366-1370.
- [17] D. Huh, B.D. Matthews, A. Mammoto, M. Montoya-Zavala, H.Y. Hsin, D.E. Ingber, Reconstituting Organ-Level Lung Functions on a Chip, *Science*, 328 (2010) 1662-1668.
- [18] S. Konishi, S<sup>3</sup> Micromachine as Multi-scale Interface for BME, *Advanced Materials Research*, 74 (2009) 3-6.

- [19] O.C. Jeong, S. Konishi, All PDMS pneumatic microfingert with bidirectional motion and its application, *Microelectromechanical Systems, Journal of*, 15 (2006) 896-903.
- [20] M. Tokida, T. Obara, M. Takahashi, M. Yamato, S. Konishi, Integration of cell sheet sucking and tactile sensing functions to retinal pigment epithelium transplantation tool, in: *Micro Electro Mechanical Systems (MEMS), 2010 IEEE 23rd International Conference on*, 2010, pp. 316-319.
- [21] S. Konishi, T. Kobayashi, H. Maeda, S. Asajima, M. Makikawa, Cuff actuator for adaptive holding condition around nerves, *Sensors and Actuators B-Chemical*, 83 (2002) 60-66.
- [22] O.C. Jeong, S. Konishi, Fabrication and drive test of pneumatic PDMS micro pump, *Sensor Actuat a-Phys*, 135 (2007) 849-856.
- [23] K. Shimizu, A. Shunori, K. Morimoto, M. Hashida, S. Konishi, Development of a biochip with serially connected pneumatic balloons for cell-stretching culture, *Sensors and Actuators B: Chemical*, 156 (2011) 486-493.
- [24] S. Kawakami, S. Fumoto, M. Nishikawa, F. Yamashita, M. Hashida, In vivo gene delivery to the liver using novel galactosylated cationic liposomes, *Pharm Res*, 17 (2000) 306-313.
- [25] J. Uozumi, C.L. Litterst, The effect of cisplatin on renal ATPase activity in vivo and in vitro, *Cancer Chemother Pharmacol*, 15 (1985) 93-96.
- [26] M. Staples, K. Daniel, M.J. Cima, R. Langer, Application of micro- and nano-electromechanical devices to drug delivery, *Pharmaceutical Research*, 23 (2006) 847-863.
- [27] N.M. Elman, U.M. Upadhyay, Medical Applications of Implantable Drug Delivery Microdevices Based on MEMS (Micro-Electro-Mechanical-Systems), *Current Pharmaceutical Biotechnology*, 11 (2010) 398-403.
- [28] N.-C. Tsai, C.-Y. Sue, Review of MEMS-based drug delivery and dosing systems, *Sensor Actuat a-Phys*, 134 (2007) 555-564.
- [29] J.H. Prescott, S. Lipka, S. Baldwin, N.F. Sheppard, J.M. Maloney, J. Coppeta, B. Yomtov, M.A. Staples, J.T. Santini, Chronic, programmed polypeptide delivery from an implanted, multireservoir microchip device, *Nat Biotech*, 24 (2006) 437-438.
- [30] P.-Y. Li, J. Shih, R. Lo, S. Saati, R. Agrawal, M.S. Humayun, Y.-C. Tai, E. Meng, An electrochemical intraocular drug delivery device, *Sensors and Actuators A: Physical*, 143 (2008) 41-48.
- [31] A.T. Evans, S. Chiravuri, Y.B. Gianchandani, A Multidrug Delivery System Using a Piezoelectrically Actuated Silicon Valve Manifold With Embedded Sensors, *Microelectromechanical Systems, Journal of*, 20 (2011) 231-238.
- [32] S. Rahimi, E. Sarraf, G. Wong, K. Takahata, Implantable drug delivery device using frequency-controlled wireless hydrogel microvalves, *Biomed. Microdevices*, 13 (2011) 267-277.
- [33] S. Konishi, T. Horie, Y. Kurumi, T. Tani, Reliable positioning of micro device for medical diagnosis and operation on pulsating targets by pneumatic suction device, *Journal of Japan Society of Computer Aided Surgery*, 11 (2009) 59-64.

## Figure legends

Fig. 1. Schematic drawing of the implantable pneumatically actuated microsystem for renal pressure-mediated transfection.

Fig. 2. (a) Picture of the developed renal case before assembly. Scale bar: 5 mm. (b) Picture of the assembled renal case. White arrowheads indicate the gap between the main part and the 1<sup>st</sup> lid to avoid clamping a ureter with blood vessels.

Fig. 3. (a) Design of the PBA used in this study. The PBA has 8 rectangular balloons ( $4 \times 3$  mm each). The width of the air channel is  $200 \mu\text{m}$ . (b) Schematic illustration of the fabrication process. The PBA consists of 2 thin layers of PDMS. The pressure-supplying port is connected to the PBA via a tube.

Fig. 4. Setup of the pneumatic pressure regulating system.

Fig. 5. (a) Procedure for encasing a kidney inside a renal case. A kidney phantom made of polyvinyl alcohol is used here for demonstration purposes. (b) Demonstration of the encasing of a murine kidney. (c) BUN level at 3, 5, and 7 days after encasing kidney.  $*p < 0.01$  versus non-treatment group (N.T.). Results are expressed as means  $\pm$  SD ( $n = 3$  or  $5$ ).

Fig. 6. (a) Picture of the developed microsystem. Left, the air pressure was supplied to the pressure-supplying port via a needle. The balloons of the PBA inflate in response to the pressure. (b) Side view of the inflated PBA balloons. Black arrowheads indicate the balloons. (c) Side view of the inflated PBA balloons in the renal case. The PBA is colored black. The side wall of the renal case was partially cut to observe the PBA in the case.

Fig. 7. (a) Effects of the duration of applied air pressure on gene expression level. Data points represent means  $\pm$  SD ( $n = 3$ – $5$ ). There was a statistically significant difference between the 4 groups (ANOVA;  $F = 5.897$ ,  $p = 0.0103$ ). A post hoc analysis (Bonferroni test) revealed significant differences between 0 and 10 s, and 3 and 10 s ( $p < 0.05$ ). (b) Effects of the magnitude of applied air pressure on gene expression levels in the right kidney. Data points represent means  $\pm$  SD ( $n = 3$  or  $4$ ). <sup>#</sup> The encased kidney was forced out of the case at 90 kPa.

Fig. 8. (a) Picture of a mouse with a completely implanted microsystem. Arrow indicates the locations of the pressure-supplying port. (b) The results of renal pressure-mediated transfection using the implanted microsystem. The luciferase levels were measured in the target right kidney, left kidney, liver, and spleen. Results are expressed as means  $\pm$  SD ( $n = 5$ ).

Movie 1. Activation of the PBA inside the renal case. The PBA was encased in the renal case. The case did not prevent the inflation of the PBA balloons.

Movie 2. Activation of the PBA inside the renal case in which a kidney phantom is encased. The PBA was encased in a renal case with a kidney phantom. The kidney phantom was pressed by the inflated balloons of the PBA when the air pressure was applied to the pressure-supplying port.

Graphical abstract. An implantable MEMS-based microsystem was developed for *in vivo* transfection to the kidneys using naked plasmid DNA in mice.

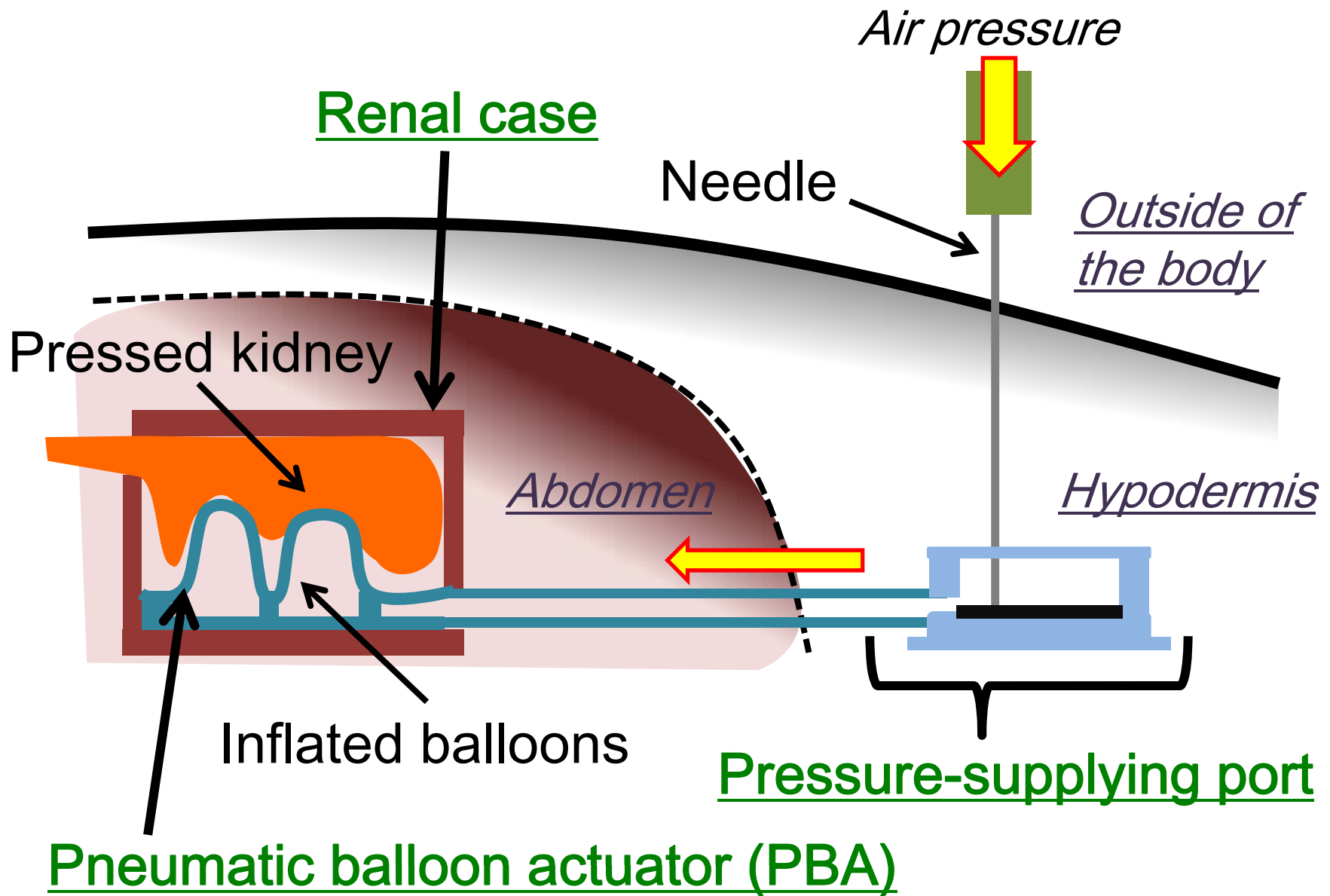
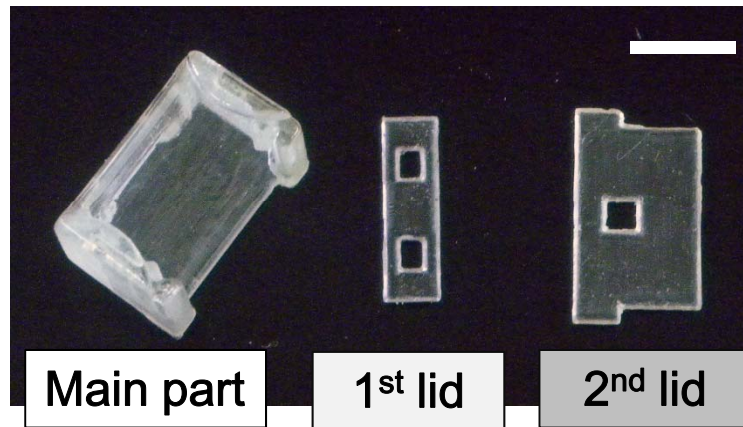

Figure 1, Shimizu et al.

a)



b)

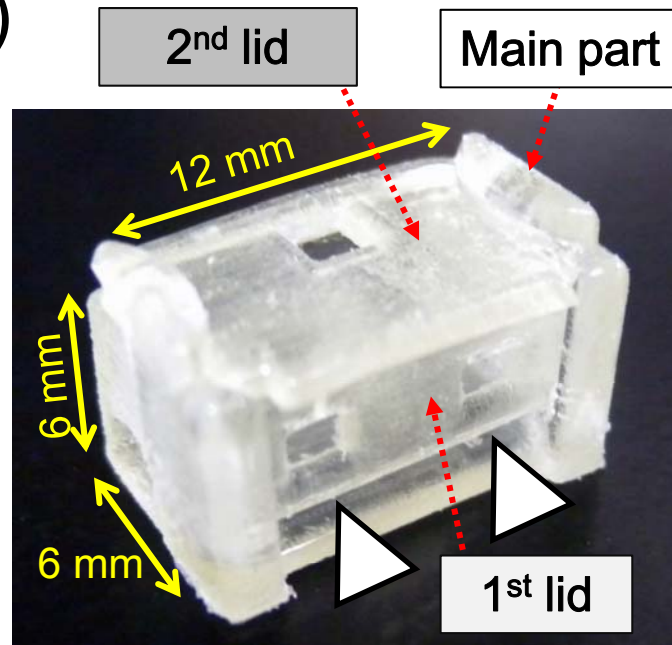

Figure 2, Shimizu et al.

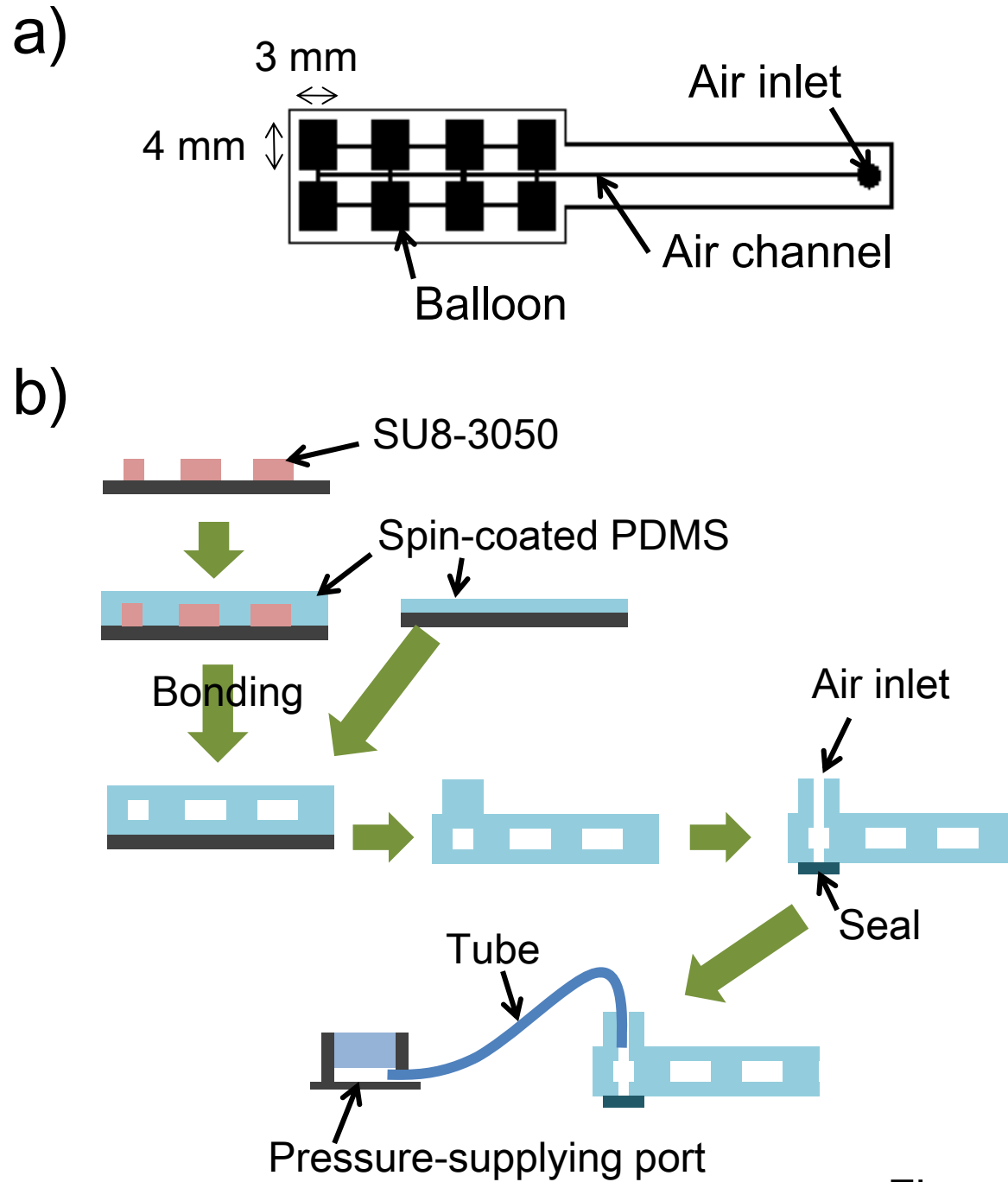

Figure 3, Shimizu et al.



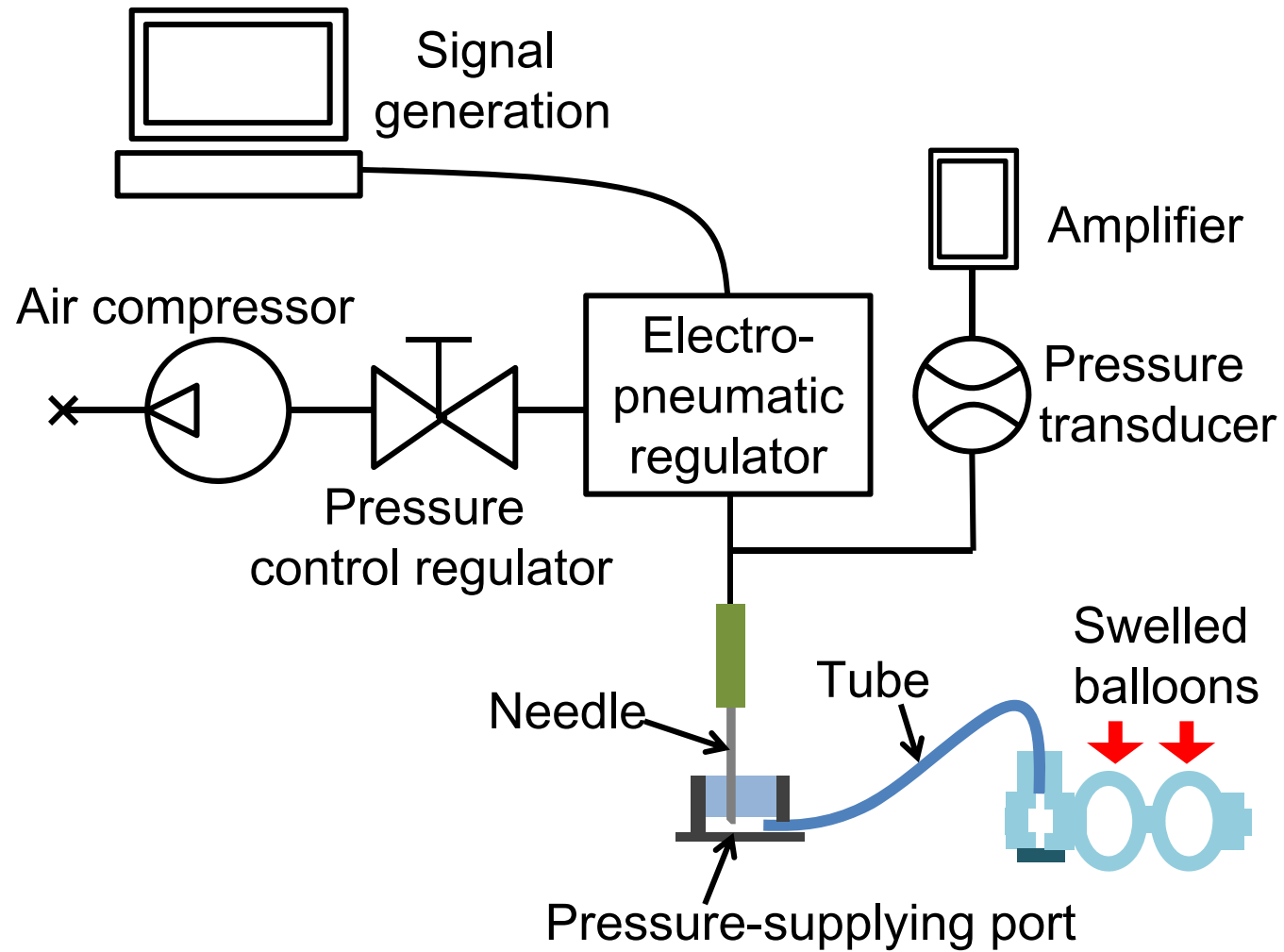

Figure 4, Shimizu et al.

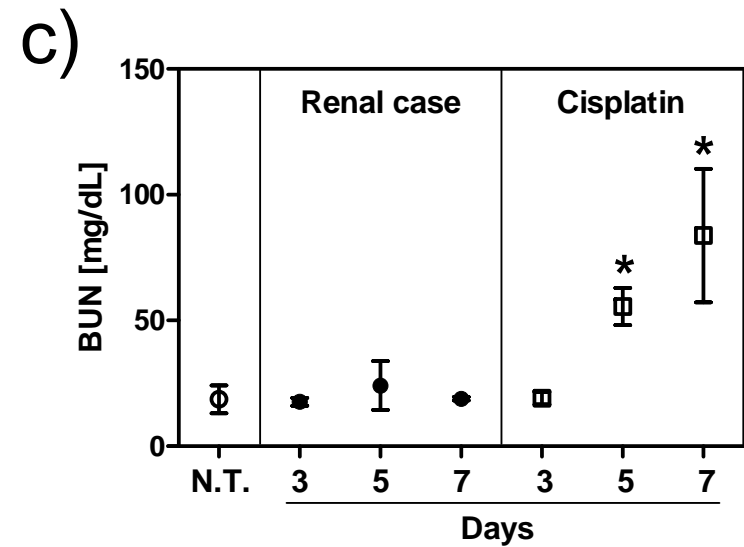
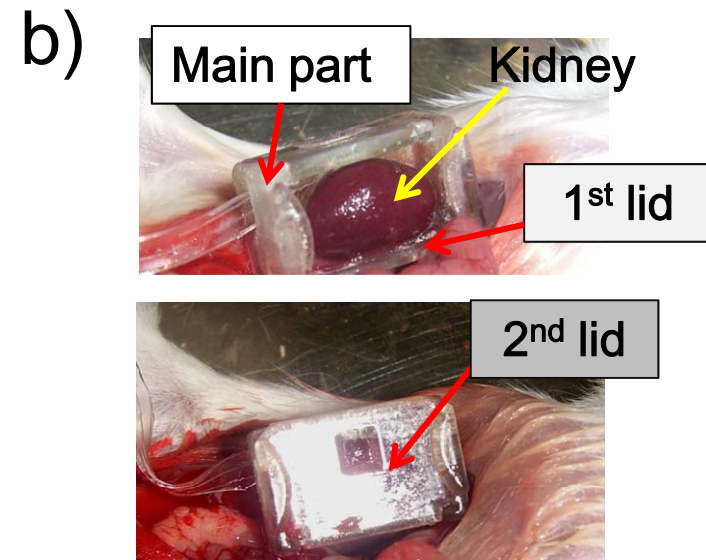
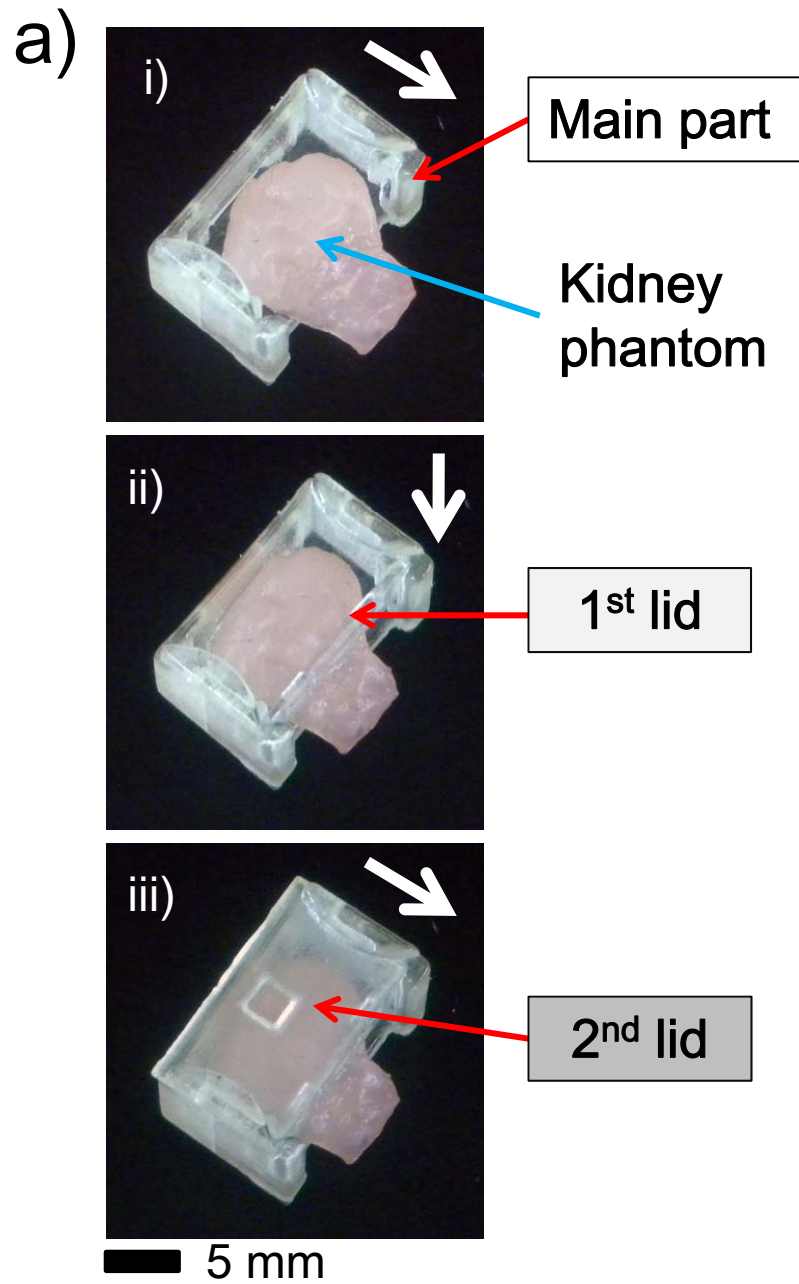
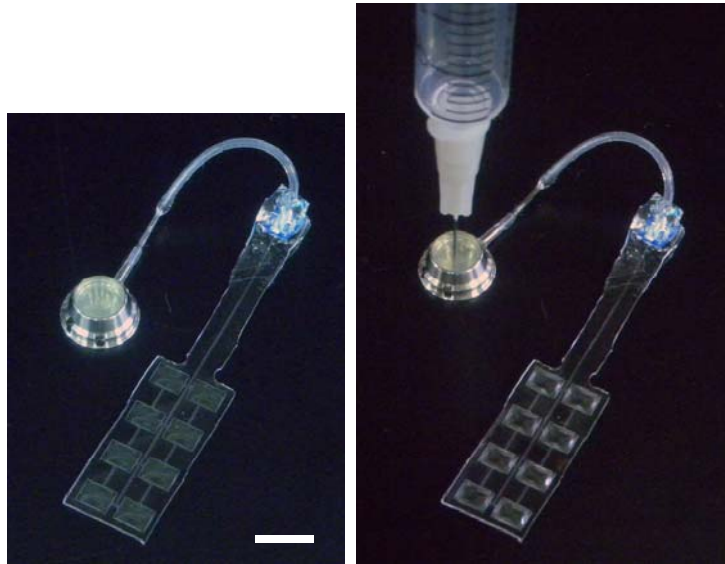
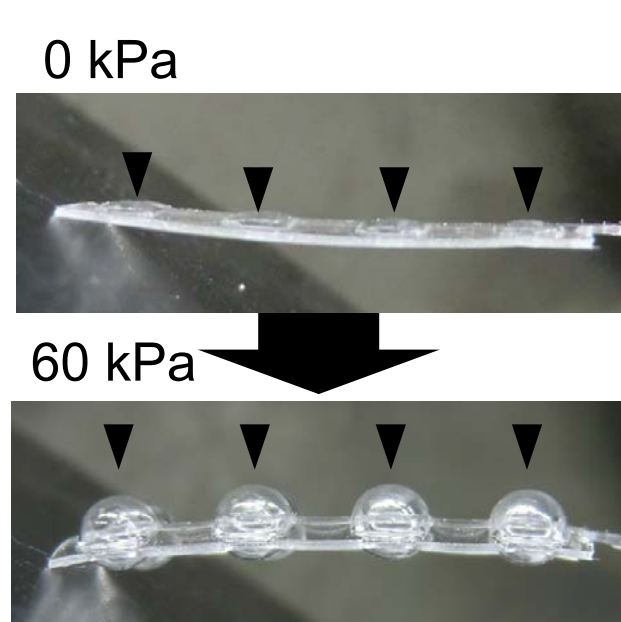

Figure 5, Shimizu et al.

a)



b)



c)

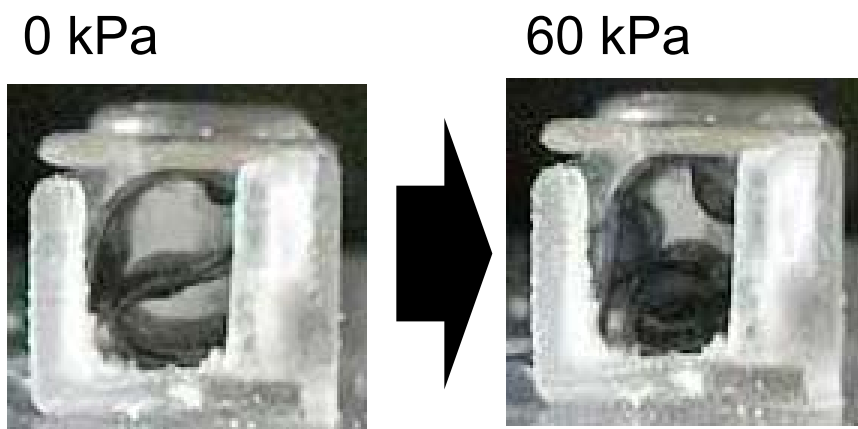
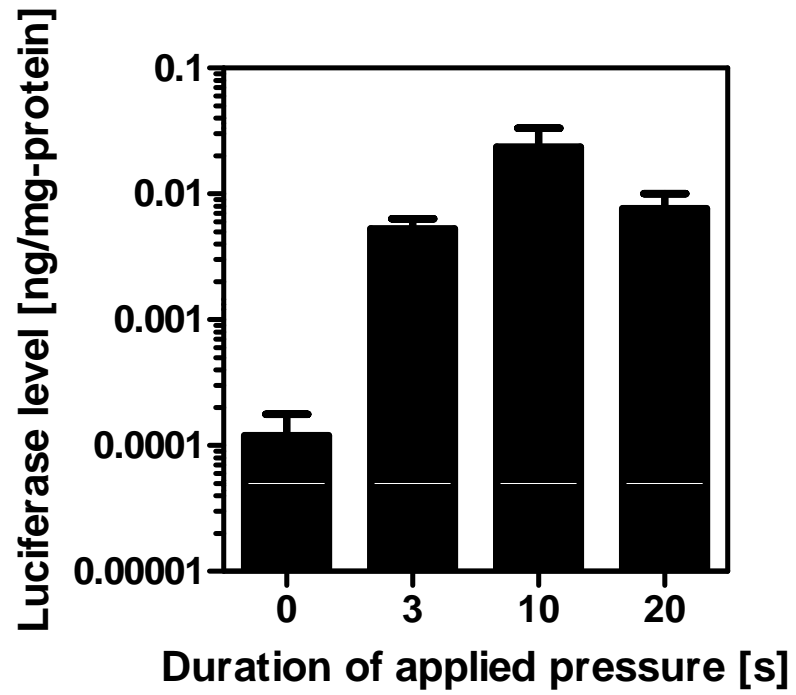

Figure 6, Shimizu et al.

a)



b)

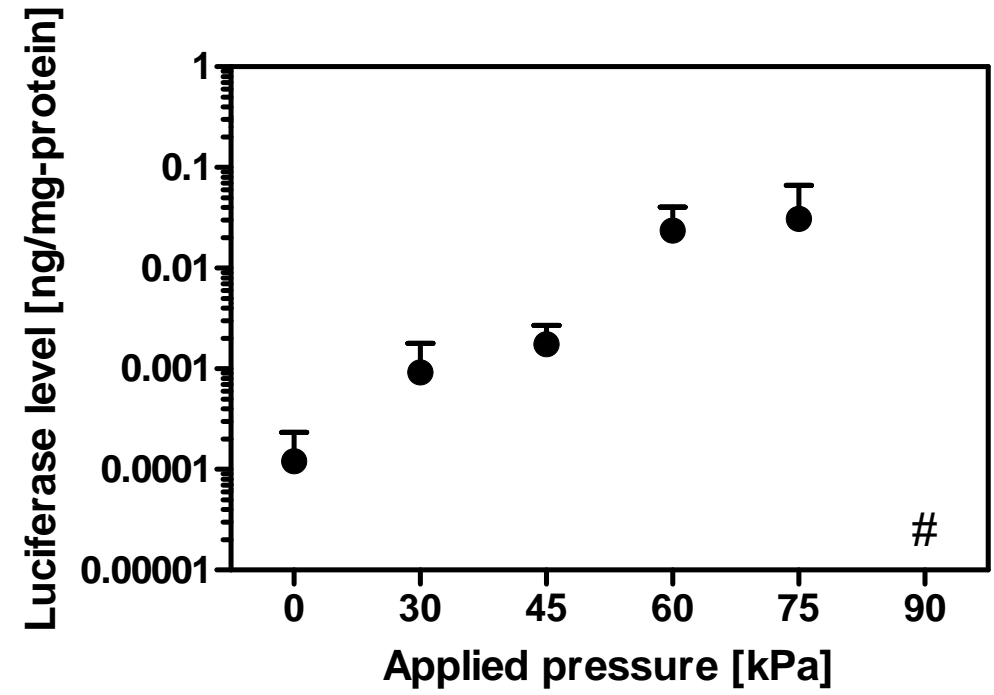

Figure 7, Shimizu et al.

a)



b)

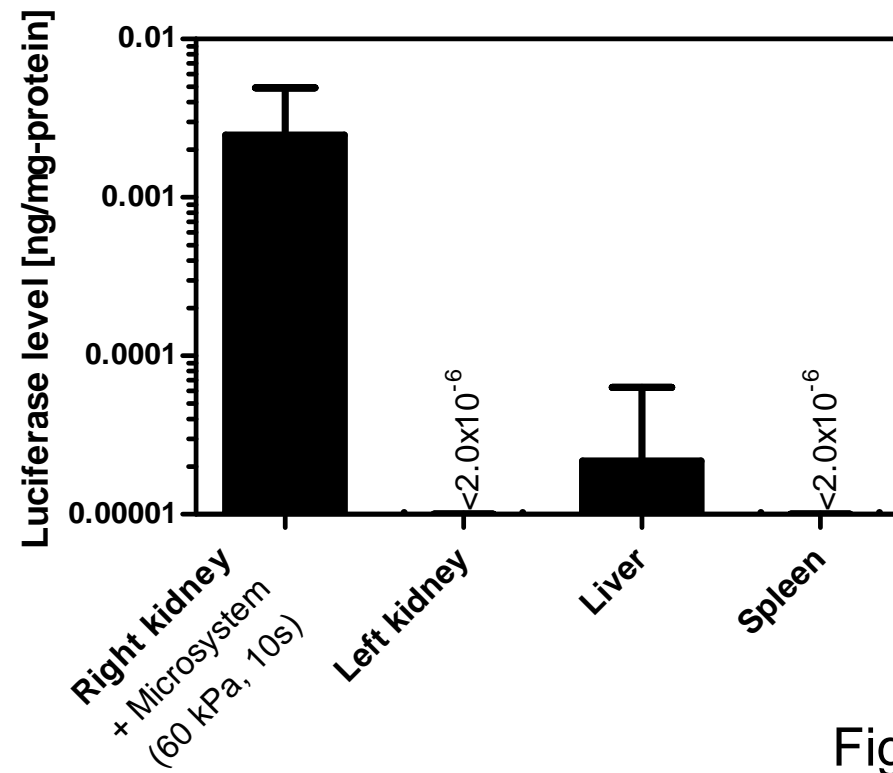

Figure 8, Shimizu et al.