

Title	Underwater Acoustic Telemetry for Oceanographical and Limnological Research (Part I)
Author(s)	KANARI, Seiichi
Citation	Bulletin of the Disaster Prevention Research Institute (1966), 15(3): 71-80
Issue Date	1966-03-19
URL	http://hdl.handle.net/2433/124705
Right	
Type	Departmental Bulletin Paper
Textversion	publisher

Underwater Acoustic Telemetry for Oceanographical and Limnological Research (Part I)

By Seiichi KANARI

(Manuscript received January 13, 1966)

Abstract

This paper describes the underwater acoustic telemetry system and some results of the field operation of this system. The system consists of two units; the one is the underwater unit (transmitter) and the other is the deck unit (receiver). The underwater unit is self-contained and can measure water temperature, and transmits the temperature information as a modulated supersonic F-M signal to a hydrophone connected to the deck unit. The received signal is demodulated to recover the original information through the deck unit which is a specially designed F-M discriminator and is then recorded on a D. C. recorder.

1. Introduction

In oceanographical and limnological studies, it is desired to measure physical quantities (temperature, current speed and electrical conductivity) continuously in space and time. For a long time, the "Bucket and Thermometer" or the "Water-Intake Thermometer" has been used for the measurement of water-temperature at the surface. From 1870 until 1938 the two principal tools in physical oceanography were the reversing thermometer, to determine water temperature, and the Nansen bottle to obtain water samples for salinity and oxygen determinations. These pieces of equipment are simple and rugged, and require no electrical cables to the ships. However, they have some disadvantages in providing data which may be valid only for a small area or short space of time, and of making such information available only upon recovery of the instrument.

In 1938 Spilhaus designed the bathythermograph which was an early practical temperature depth recorder. In 1941, Ewing, Worzel and Vine modified the bathythermograph considerably by adapting the Spilhaus's instrument to be used as a diving instrument. But this instrument also has the disadvantage of making its information available only upon recovery, and can not record the variation of temperature (or other quantities) with space and time at one point.

In recent years, some instruments which can electrically measure water temperature, current speed and electrical conductivity, etc., have been developed, which transmit the data through an electrical cable and give a continuous record. Although an instrument of this type is very useful in shallow water because of its reliability, and can supply continuous information, all these advantages are eliminated by the fact that it requires electrical cables to con-

nect the sensors and indicators (or recorder). Anyone who must operate the instrument at sea soon discovers that electrical cables are cumbersome to handle on deck, furthermore, for deep sea observation they require a large winch and some installations. They are often subject to large strain which result in breaks in the strands, and its replacement will be a time consuming and very expensive process.

In the atmosphere, it is possible to transmit the data as a monitored radio wave, and this method is used for radiosonde and high altitude observation with rocket. Although a body of water does not transmit any radio waves, sonic waves can be transmitted through great distances with little attenuation and a highly efficient echo ranging and echo sounding instrument has been developed which takes advantage of this phenomenon. Therefore, if we can transmit the desired information with sound waves modulated by employing the same principles and coding techniques already developed for radiosonde and rocket telemetry, then we have no need of cable for the data transmission, and we will be released from the troubles of cumbersome and expensive cable gear. Such a method was developed by Dow Willard in 1954. He constructed the telemetering device which transmits the depth of a trawling net to the ship acoustically during its towing.

In 1962, we designed an acoustic telemetry system which transmits and records the data on water temperature and depth alternately, based upon the same principle as that described above. The following are the details of the telemetry system and its applications in field observation.

2. General description of the underwater acoustic telemetry

As shown in the block diagram (Figure 1), the telemetry system consists of two units; the one is an underwater unit (transmitter) and the other is deck unit (receiver). The underwater unit has two oscillators, the frequencies of which vary in accordance with water temperature and pressure (hydrostatic pressure) respectively, and their outputs are selected alternately by a mechanical commutator, and then amplified to a power level required for transmission. The amplified signal drives a sound projector, an electromechanical device which converts the electrical signal into a sonic wave.

The transmitted signal is picked up from the water by a receiving hydrophone, and converted again to an electrical signal and amplified through the

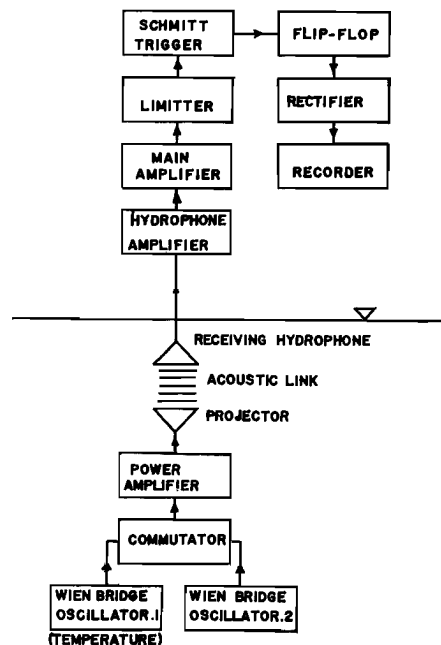

Fig. 1. The schematic block diagram of the underwater acoustic telemetry system.

main amplifier to a level of saturation. At this level, it is applied to a differential circuit and converted to a negative and positive pulse train in such a way that the number of pulses in unit time is proportional to the frequency of input signal. Therefore, by rectifying these pulses and smoothing, we can determine the frequency of input signal as D. C. voltage, calibrated in terms of frequency which is a function of temperature or pressure.

3. Electronic design

The underwater unit (transmitter of sonic wave) generates a carrier sound wave between approximately 10 kc and 21 kc in accordance with water temperature change from 10°C to 30°C by the following procedure. Water temperature change is converted to frequency change through a phase shifting network of a Wien Bridge oscillator, in which two thermistors T_{h1} and T_{h2} are contained as frequency determining elements as shown in figure 2. These thermistors and additional capacitors C_1 and C_2 constitute the arms of the Wien Bridge oscillator circuit, which determines the output frequency of this oscillator, and its frequency is given approximately by the following formula ;

$$f = \frac{1}{2\pi\sqrt{C_1 C_2 R_1 R_2}}$$

Where, R_1 and R_2 are the resistance of the thermistor T_{h1} and T_{h2} respectively. Especially, if C_1 and C_2 are constant ($=C_0$), and $R_1 = R_2 = R$, then the frequency is

$$f = \frac{1}{2\pi C_0 R} \quad (1)$$

On the otherhand, the thermister resistance at a given temperature is expressed by the following formula ;

$$R = A \exp (B/T) \quad (2)$$

where, A and B are constants depending on the thermister material, and T is the absolute temperature in degree K . From eq. (1) and (2) the output frequency in terms of temperature is given as follows.

$$f = \frac{1}{2\pi C_0 A} \cdot \exp\left(-\frac{B}{T_0+t}\right) \quad (3)$$

where, $T = T_0 + t$; t is the water temperature in degrees C , and $T_0 = 273^\circ K$.

In laboratory test, it was recognized that the frequency variation has a hysteresis, which was due to the self heating of thermister elements and it could be eliminated by using thermistors with high resistance ($7 K\Omega$ at $30^\circ C$) and small thermal time constant in the required temperature range. Thermal time constant of the thermistors in stirred water was found to be about 0.1 seconds, which is low enough for most applications. As the thermistors are subjected to water pressure, it has been tested to the hydrostatic pressure of 100 atm and it was found that such pressure has no effect on their resistance at constant temperature.

Voltage change of power source results in instability of the frequency of the generated signal, but it could be stabilized by using a mercury battery as

the power source of the oscillator. Though the stability of the oscillator also depends on the surrounding temperature, it was easily compensated by special capacitors with positive temperature dependency, in the arms of a frequency determining circuit. Figure 3 shows a temperature v. s. frequency calibration

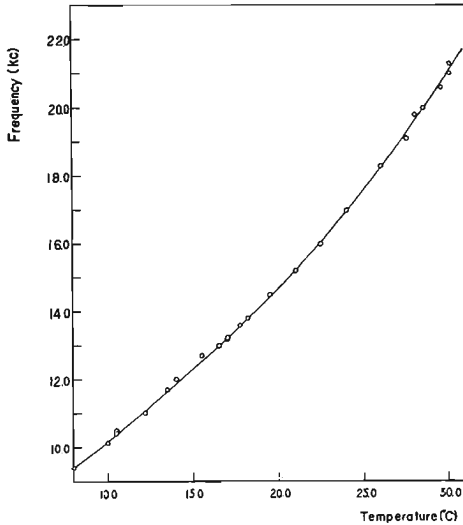

Fig. 3. Temperature v. s. frequency calibration curve of the temperature measuring oscillator measured in the laboratory.



Fig. 4. General view of the deck unit (receiving hydrophone, demodulator and recorder).

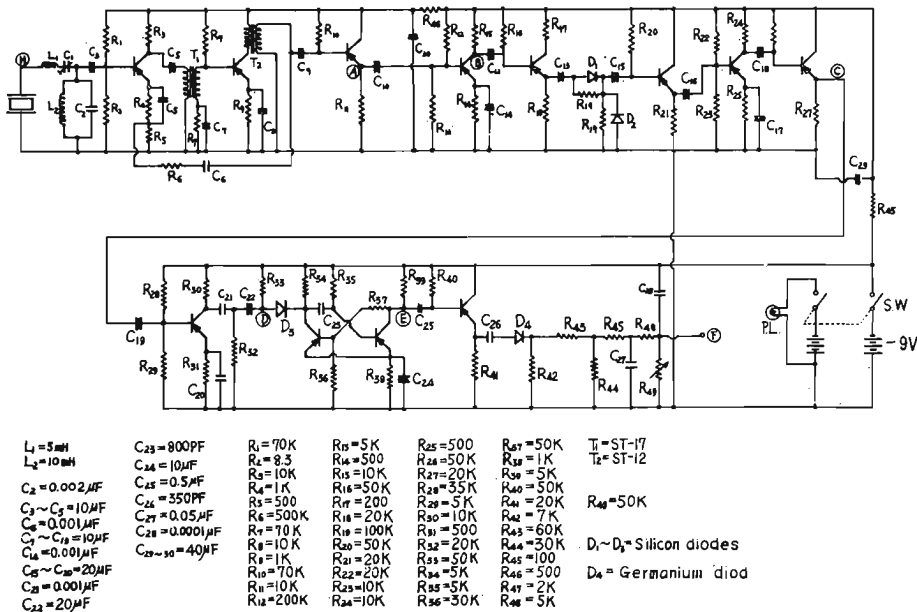

Fig. 5. Circuit diagram of the deck unit. The terminal F is connected to the recorder input.

curve of the temperature measuring oscillator measured in the laboratory.

Another Wien Bridge oscillator in figure 2 was designed for measuring the depth of the transmitter, but because of a fault in its pressure sensor, it was used only as a reference signal generator with a frequency of about 10 kc.

The output signals of these two oscillators are selected alternately every two seconds and amplified through a driver amplifier T_3 and after passing through the wide band class-B power amplifier T_6 and T_7 they drive the sound projector (electro acoustic transducer), which has about 30 v in rms of the terminal voltage at a frequency of 20 kc under the proper loading, the electrical input power is about 0.5 watts. However, impedance characteristics of the transducer have a frequency dependency, and it is very difficult to take impedance matching all over the required frequency range. This means that the transducing efficiency depends on the driving frequency, and it was estimated from the laboratory test that the highest efficiency is about 15 per cent at the frequency of 20 kc and acoustic total power emitted at that frequency is about 0.075 watts, which may be too low for long range transmissions; the maximum transmission range of 100 m is available on condition that the attenuation coefficient is 4.3 db/km, sound pressure is about 10^3 dyne/cm² at the index point of 1 m from the sound projector and the minimum input of the receiving amplifier is $50 \mu\text{v}$ (sensitivity of the hydrophone is $5 \times 10^6 \mu\text{v}/\text{dyne}/\text{cm}^2$).

The relay circuit containing two platinum electrodes in the figure 2 permits the transmitter to be switched "on" automatically when the transmitter is lowered into the water, and "off" when the transmitter is on the deck.

Figure 4 shows a receiving hydrophone and deck unit, in which the torpedo-shaped receiving hydrophone contains a band pass pre-amplifier, and it is connected to the deck unit through an electric cable about 10 m long. Figure 5 shows a circuit diagram of the hydrophone pre-amplifier and receiver. The output signal of hydrophone pre-amplifier is further amplified by T_4 , and its amplitude is sliced in an approximately constant level while passing through from T_5 to T_9 . They are applied to C-R differentiator C_{21} and R_{32} , and generate a negative and positive pulse train, and then trigger a mono-stable multivibrator T_{10} and T_{11} , and finally generate a rectangular wave train with accurately constant amplitude and constant width of 40μ sec. After being rectified by D_4 , they are smoothed by low pass filter R_{45} and C_{27} , and the resultant D.C. output is recorded. The D.C. output varies from 0 to 0.1 volts in accordance with the frequency change from 10 kc to 21 kc.

4. Structural design

The transmitter circuit is contained in two brass tubes about 1.5 m long and 5.0 cm dia as shown in figure 6. One of them is mainly packed with batteries as shown in figure 7. The two thermistors and the temperature sensor, are mounted on the end cap of another tube, and electrical

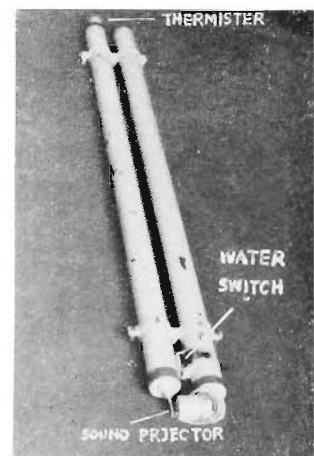

Fig. 6. General view of the underwater unit.

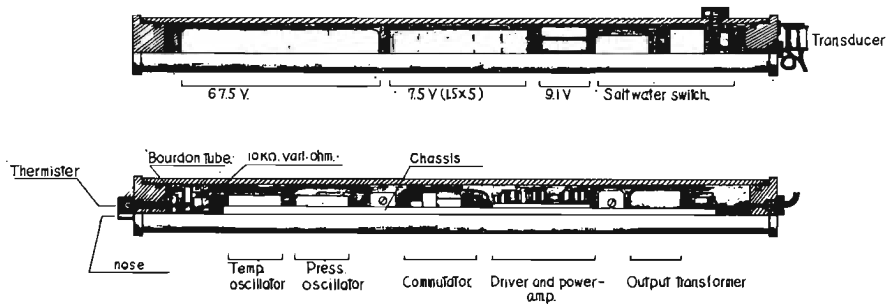

Fig. 7. The schematic diagram of layout of component assembly in the underwater unit.

connections between the two tubes are made by sealed feedthrough connectors. The acoustic transducer is mounted on the upper end cap of one tube, sealed by O-ring so that they can be easily removed when the battery must be replaced.

The insulated two platinum electrodes mounted on the wall of a brass tube is connected to a relay circuit in the same tube, and when the transmitter is immersed in the water, the electrodes are connected to ground via the water path, and it energizing the relay and turning on the transmitter circuit. The total weight of the transmitter is about 38 kg in water and 43 kg in air.

5. Examples of records

A laboratory test on modulated sound signal transmission was made by using a rectangular water tank 78 cm wide, 7.2 m long and 78 cm deep. The receiving hydrophone was set at one side of the tank, and the transmitter was suspended at the other side so that the acoustic transducer might be faced toward the hydrophone. In this test, temperature change was given by cooling or heating the temperature sensor of the transmitter and at the same time, a rough measurement of temperature change was made by a mercury thermometer. Figure 8 is a typical example of telemetered record obtained from the laboratory test, and figure 9 shows the comparison of temperature change

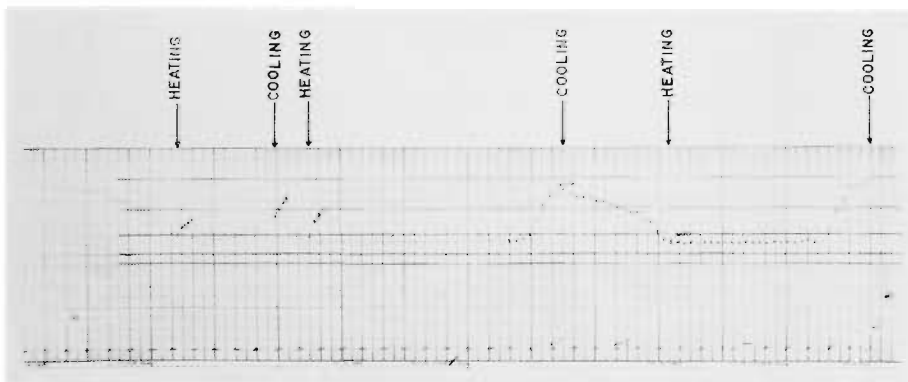

Fig. 8. A typical example of telemetered record obtained from the laboratory test.

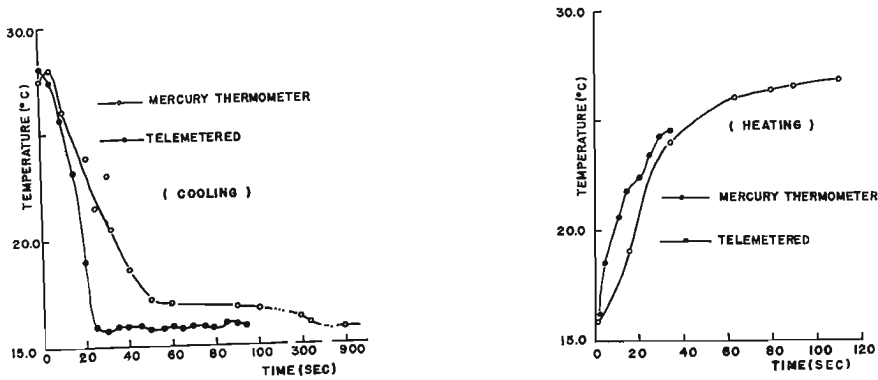

Fig. 9. Comparison of temperature change between the mercury thermometer and the reading of telemetered record obtained from the laboratory test.

between the mercury thermometer and the reading of telemetered record. A large discrepancy in temperature change is due to the difference in thermal time constants between two pieces of equipments.

Figure 10 is another example of telemetered record obtained from the sea trial at 6 miles south-west off Seto-Saki in the Kii straits, on Dec. 2, 1963. In this trial, the transmitter was lowered slowly from the surface to the layer of 50 meters depth, and it transmitted the data of vertical temperature distributions to the receiving hydrophone on the surface.

In this record, it failed to record the pressure change because of the fault in the pressure transducer, therefore, the transmitter position was measured by the length of suspended wire, as shown in figure 10. As the vertical temperature gradient was extremely small during this trial, it was unable to show an

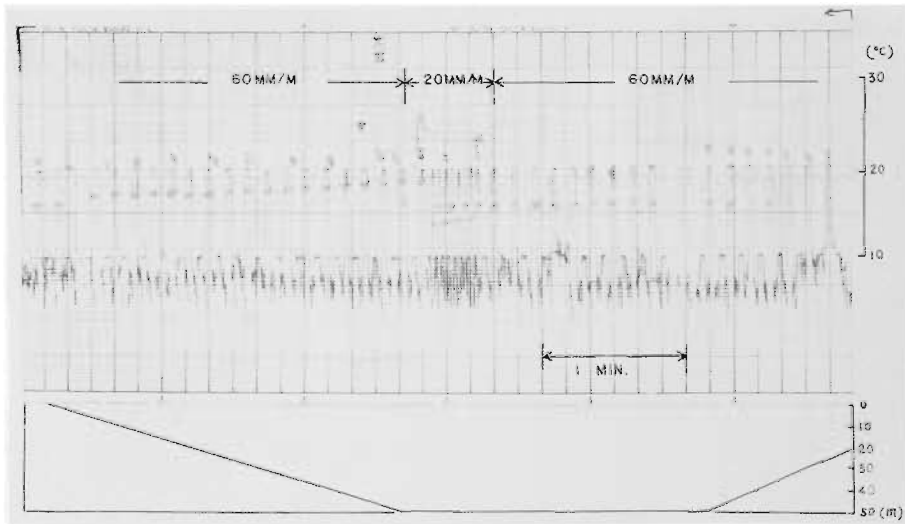

Fig. 10. An example of telemetered record obtained from the sea trial at 6 miles of south west off Seto-Saki in Kii straits, in Dec. 2, 1963.

interesting temperature record. The overall relative accuracy of the record was about 0.5 per cent, which was determined by means of a comparison with the reading obtained at the same time, of reversing thermometer as shown in figure 11.

A test of horizontal transmission was also carried out in shallow water near the pier of Seto Marine Laboratory in Tanabe Bay. The maximum transmissible range was about 200 meters in horizontal, but at this range it was impossible to receive a stable sound signal because of multi-path interferences, and it may also be responsible for an extremely small acoustic power and a broad directivity of the sound projector and the receiving hydrophone.

Although the transmission range was short, comparatively good results were obtained from the test so far as the vertical transmission is concerned. As pointed out in the introduction of this paper, the telemetering system does not need any electrical cable to transmit information, and will be available for the observations of deep seas and lakes.

The author is planning a new design of a telemetry system whose total output power will be about 5 watts. The new system has 5 channels; water temperature, depth, turbidity and two standards, in which the F-M/F-M modulation will be used for the acoustic main carrier of 40 kc. Because of the narrow bandwidth, it is expected that the electric power might be transduced to acoustic power with relatively high efficiency. Full information on the new system will be given in a future report.

The author wishes to thank Dr. S. Hayami for his valuable suggestions on the telemetry system. He also expresses his thanks to Dr. H. Kunishi and several members of the staff at the Oceanographical Laboratory of Geophysical Institute of Kyoto University for their valuable help and advice on construction and sea trials of this instrument.

References

- 1) Vine, A. C. ; Oceanographic Instrumentation for Measuring Temperature, Report of Naval Research, 1952.
- 2) Snodgrass, J. M. and Cawley, J. H. Jr. ; Temperature and depth circuitry in a tele-recording bathythermometer, contributions from the Scripps Institute of Oceanography, New Series, No. 880, pp. 183-821.
- 3) Willard, D. ; Underwater telemetering, Deep Sea Research, Vol. 2. 1954, pp. 145-151.
- 4) Hamon, B. V. and Brown, N. L. ; A temperature-chlorinity-depth recorder for use at

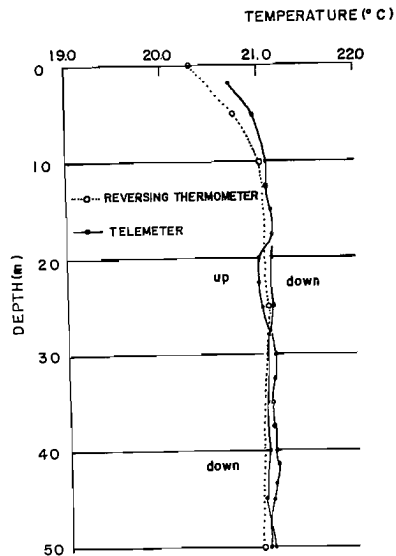

Fig. 11. Comparison between the reading of telemetered record and the reversing thermometer reading, obtained from the sea trial at 6 miles of south west off Seto-Saki in Kii straits, in Dec. 2, 1963.

- sea, *Journal of Scientific Instrumentation*, Vol. 35, 1958, pp. 452-458.
- 5) Spilhaus, A. F. ; A bathythermograph, *Journal of Marine Research*, Vol. 1, 1938, pp. 95-100.
 - 6) Jones, F. E., Hooper, J. E. N. and Alder, N. L. ; The radar sonde system for the measurment of upper wind and air data, *Symposium of papers on electrical meteorological instruments-Session II*, 98, part II, pp. 471-469.