

Geolocation Apps using A* Algorithm for Android Based Traders

Istithoatun Kholishoh, Mardainis, Susandri, Khusaeri Andesa

Informatics Engineering Study Program, STMIK AMIK Riau

istithoatun.kholishoh24@gmail.com, mardainis@gmail.com, susandri@sar.ac.id, khusaerandesas@sar.ac.id

Article Info

Article history:

Received August 4, 2020

Revised Sept 10, 2020

Accepted Mar 8, 2021

Keyword:

Android
A Star Algorithm
Geolocation
Traveling Merchants

ABSTRACT

The development of technology has a positive effect on the trade sector, creating smartphones that can be utilized in all activities combined with the internet network. Activity that is currently growing is a mobile trader in the city of Pekanbaru. This development caused much competition, for example, in the Pekanbaru city area, especially in Sialangmunggu village. Traders around is difficult to find consumers because consumers do not have precise location and time information. Therefore, researchers aim to design and build applications by utilizing the functions of google maps and GPS (Global Positioning System) where the Algorithm to be applied is the A* algorithm whose function is to find the nearest location between buyers to mobile merchants, to accommodate data from mobile merchants where buyers can know the nearest position of the traveling merchant. Process analysis will be divided into running analysis that discusses the workings of the process of mobile traders and buyers in the field. Then the proposed system analysis of the analysis will be made by the author to maximize the process on the current analysis. By making analysis and design, the author will know the needs needed in the creation of the system. The result of using method A* is applied to displaying the merchant's route with the user, and the result can provide the fastest route to get to the trader. The use of method A* is also done to find the trader whose location is closest to the user's location, and the result can display the nearest trader.

© This work is licensed under a Creative Commons Attribution-ShareAlike 4.0 International License.

Corresponding Author:

Istithoatun Kholishoh,
Informatics Engineering Study Program,
STMIK Amik Riau,
Purwodadi Street, Pekanbaru, Indonesia, 28294
Email : Istithoatun.kholishoh24@gmail.com

1. INTRODUCTION

The development of technology in the era of globalization that continues to grow affects the trade sector. These developments have had a positive impact. In general, the development of technology such as smartphones as the most advanced technological devices today, which has an operating system that is android. Users of this technology can be utilized in all activities by combining the internet network. One of the activities that are currently developing is a mobile merchant in Pekanbaru city.

According to [1], street vendors' existence is considered a form of expansion in creating jobs from both urban and rural areas.

Mobile traders are traders who sell trade goods such as food, cakes, and other beverages with a mobile system using motorcycles or on foot. The number of mobile traders in the Pekanbaru city area, especially in the village of Sialangmunggu, makes it difficult for mobile traders to find consumers because mobile traders do not have precise location and time information for prospective buyers.

The case that is still visible is the relationship between buyers and mobile traders who do not know any information on the traveling merchant, so there are often cases where the buyer desires to transact with the traveling merchant. However, the traveling merchant does not have certainty of information such as the location and sale time.

Research conducted by [2] explains that applying the A* algorithm to the help menu in maze adventure games is already running using Euclidean heuristics [4]. Research has found that an application can provide information on nearby roads, where designation uses google. The research conducted by [2] A* algorithm testing rate reaches 80% can point to the closest distance [2]. found that finding the closest path to the hospital using the application of the A* algorithm and shooting star algorithm was successfully proven.

Research conducted by [6] searched for the shortest route from the current teak road to STMIK Nusa Mandiri campus through two roads, using A* algorithm to find the shortest route. The research conducted by [7] implemented A* algorithm to find the closest distance in case of congestion on the highway.

Research conducted by [8] there is this research A* algorithm used on the navigation of hexapod robots to search for the shortest path. Hexapod robot is one type of robot, where the movement of this robot is assisted by using six legs. Research conducted by [9] implements A* algorithm method as a team like game creation on the process of chasing the player's enemies.

Research conducted by [10] using google maps advice as a medium to find the route and distance of app users in Samarinda city.

Based on the problem, researchers will provide solutions by designing and building applications by utilizing google Maps and GPS (Global Positioning System) functions where the Algorithm to be applied is the A* algorithm whose function is to find the nearest location between buyers to mobile merchants. The creation of this application is expected to be able to accommodate data from mobile traders where buyers can know the nearest position of the traveling merchant.

The difference between the research from [4] and the research that the researcher will make is located in the determination of the shortest path. Research from [4] explains that in search of culinary tours, the shortest path is expected to login first to find the shortest location, then the maps display will appear, while the research made today is the user login first because the main view of the mobile merchant application is the Google Maps view so that the location of the traveling merchant is already listed at the maps point. If the user wants to search for mobile traders select the mobile merchant icon in the maps view.

2. RESEARCH METHOD

The stages in this research activity are as follows:

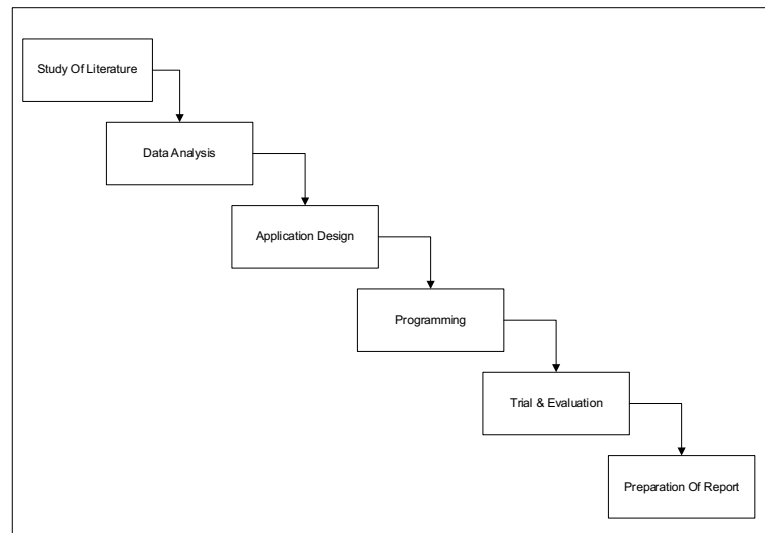

Figure 1. Stages of Research

- a. Literature studies are conducted through observations on objects or research objectives by the problem, and the purpose of the research is by observing directly to the traveling traders in the village SialangMunggu. The author identifies the leading cause of mobile traders' problems as the absence of accurate merchant information.
- b. Data analysis is done to process mobile traders' data needed to complete the completeness of data on mobile merchant applications. The required data is route data, graph, and personal data such as name, email, mobile number.
- c. The design of the application explains the overview of the system, as well as the proposed model, which will result in object-oriented software.
- d. Program creation using java android programming language because the resulting application is an android application.
- e. Trials and evaluations are conducted on the system to find out the resulting application can run smoothly.
- f. The preparation of doing it report after all stages have been completed and have been evaluated

2.1. Analysis

The analysis process will be divided into running analysis that discusses the workings of the process of mobile traders and buyers in the field. Then the proposed system analysis of the analysis will be made by the author to maximize the process on the current analysis.

1. Current System Analysis

This analysis of the current system will discuss the process that runs on the search for mobile traders now. The initial process of searching for mobile traders comes directly to the traveling merchant's place who is a subscription or if you do not have a subscription, then directly search for the traveling merchant manually.

2. System Built Analysis

In the analysis system built, this will discuss the process that will run on the system that will be made. The process that happens to the system that will be built is that the application users will look for a list of mobile traders scattered in Sialangmunggu Pekanbaru village. The application will recommend small mobile traders who have good quality to increase the sales of mobile traders. In addition, by applying map search, the app

will be able to direct the user to search for the location of the traveling merchant intended by the route created by the A* algorithm. By knowing the predetermined route, the mobile merchant's position on the map will be more accurate than the creation through Google Maps. The result will be to display the route to the selected mobile merchant, and the route shown will be more optimal because it is created using the A* algorithm.

3. The Process of How A* Algorithm Works

The steps in completing the A* algorithm to get the shortest route in the case of this mobile merchant service are as follows:

- a. Specifies nodes or nodes with distances taken from google maps in meters.
- b. The notations used by A* Algorithm are as follows:

$$f_n = g_n + h_n \quad (1)$$

Description:

f_n = lowest estimated cost

g_n = cost from initial node to node n

h_n = estimated cost from node n to end node.

- c. In the implementation, has meaning, node (*nodes*), A, open list, closed list, price (*cost*), obstacle (*unwalkable*).
- d. Search for the shortest path from the original location to the destination location.

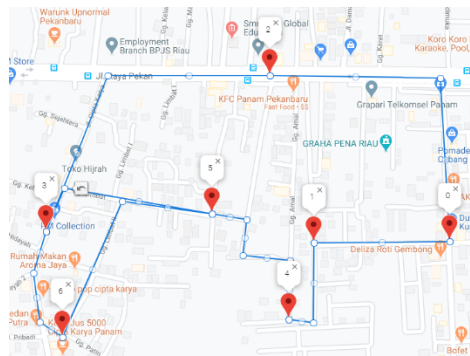

Figure 2. Mobile Merchant Trail

In figure 3 above is the boundary of the area of mobile traders in the village Sialangmunggu. if the location of the traveling merchant is outside the map that researchers have determined, then the location of the traveling merchant only shows the location of the street where the merchant is located.

2.2. Knowledge Base Analysis

Needs analysis is the phase of studying the needs used to find what is systemically necessary. A need relating to the benefits or phases of change must be done and completed by the software. Here are some points that become a reference in functional needs:

1. The system can be a reference for users of the application searching for qualified and affordable mobile merchants. Even if the trader moves around, the trader will be connected to the nearest node.
2. The system can be a reference for small mobile traders to further increase income.
3. The system can reference the results of the use of A* Algorithm in this study.

2.3. System Design

The approach is the stage after the analysis of the system that is fundamental to objects (Object Oriented) that use UML and divided into two namely:

1. Global Design

Depiction of the system's flow to be built to the user about the system to be designed. This global design includes use case diagrams, sequence diagrams, and class diagrams.

- Use case Diagram

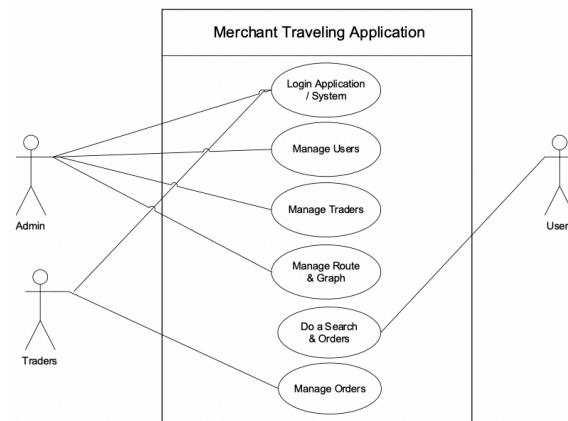

Figure 3. Use Case System Diagram

Before the user uses the application is required to login first. After login admin can input user data, the route will be used for search with Algorithm A*.

2. Sequence Diagram

- Sequence Diagram Login System

The system created requires a login page because the search system must recognize the user logged in to the system. The following is an overview of the sequence diagram to open the system.

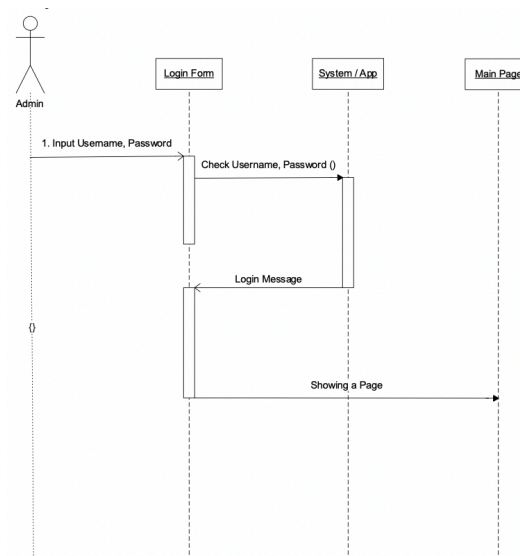

Figure 4. Sequence Diagram Login System

- Sequence Diagram Managing User Admins

The Sequence Diagram below illustrates the flow of admins inputting the user to be used in the admin system's login process. In this process the user is input in the form of identity data such as username, password and user name. In the process will be described in the form of the following diagram sequence:

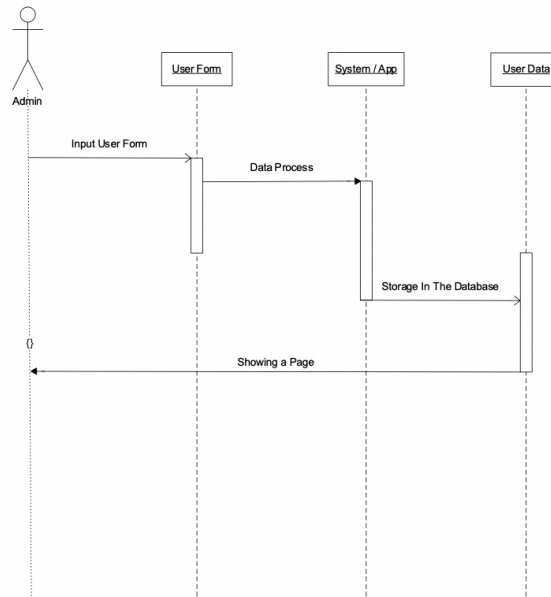

Figure 5. Sequence Diagram Managing User Admins

- Sequence Diagram Managing Mobile Merchants

Sequence Diagram below illustrates the flow of admins in entering data traveling merchant in the village of Sialang Munggu Pekanbaru. The following is a sequence diagram overview for managing mobile traders.

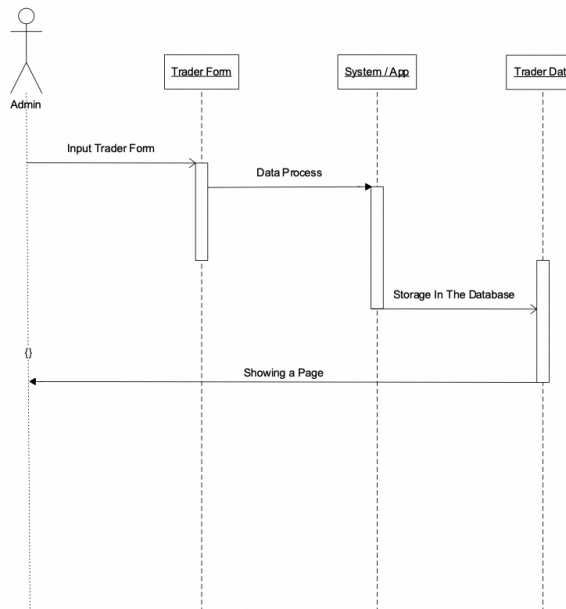

Figure 6. Sequence Diagram Managing mobile merchants

- Sequence Diagram Managing Route Data

The sequence Diagram below illustrates the flow of admins in processing route data leading to mobile traders in SialangMunggu Pekanbaru village. The following is a sequence diagram for managing route data

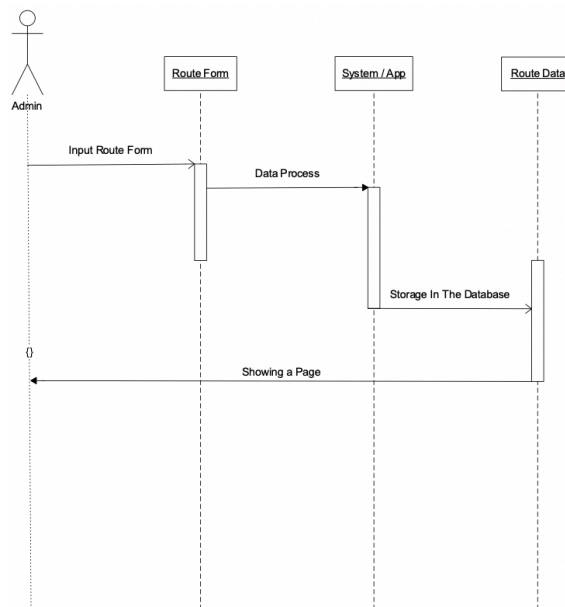

Figure 7. Sequence Diagram Managing Route Data

3. Diagram Class

The Diagram class describes the state or attributes of the system. The interconnected Diagram class can be seen in the following figure:

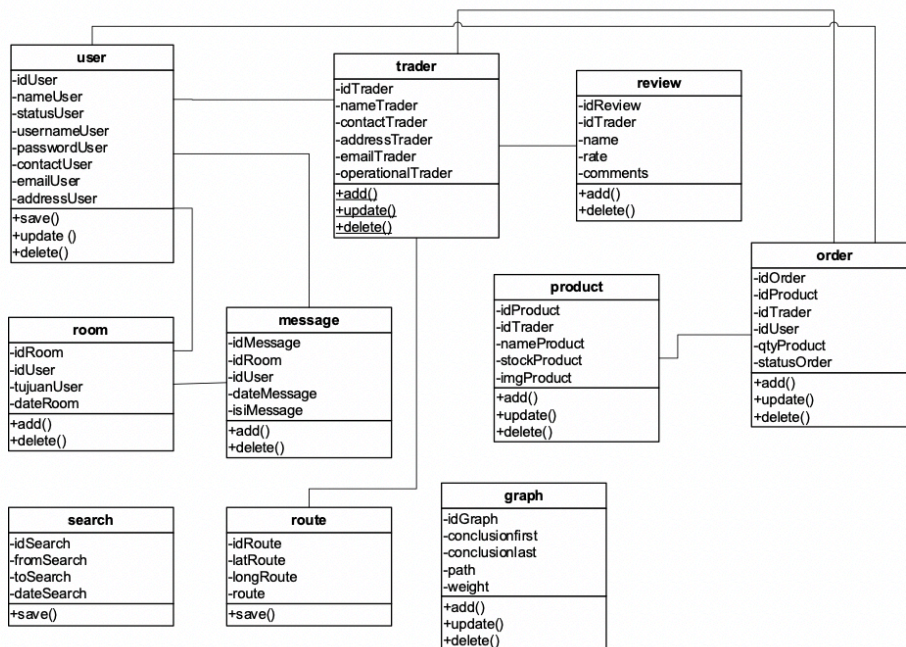

Figure 8. Class Diagram

3. RESULTS AND DISCUSSION

3.1. A* Algorithm Calculation Results

Specifies nodes or nodes with distances taken from google maps in meters. The cost value of each path is determined first.

Description:

A, B, C, D, E, F, G = node/ vertex is the point in the specified folder.

Connecting line node = line distance between node 1 and other.

Table 1. Cost value of each node

N	A	B	C	D	E	F	G
h(n)	0	80	70	70	75	70	0

How to first, because OPEN there is 1 vertex (A) selected to be Best Node, then f(C)=80

Closed: A, Open: B, D

$$f(n) = g(a) + g(a \text{ ke } d) + h(a)$$

$$F = 0 + 634 + 70 = 704$$

$$f(n) = g(a) + g(a \text{ ke } b) + h(a)$$

$$F = 0 + 257 + 80 = 337$$

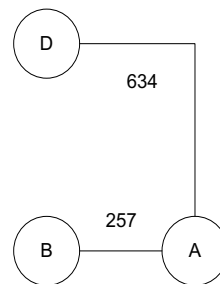

Figure 9. First Step

$$f(n) = g(a \text{ ke } d) + h(a)$$

$$F = 0 + 634 + 70 = 704$$

$$f(n) = g(a) + g(a \text{ ke } b) + h(a)$$

$$F = 0 + 257 + 80 = 337$$

The result of the first step of the calculation of node A-B is 337. Initial comparison between A-D node and A-B node. The result is node A-D which is 704 and node A-B is 337. Second, B with the lowest financing, (337) was raised to Best Node, moved to CLOSED, succession B was opened and entered into OPEN.

Closed : A,B, Open : C.

$$f(n) = g(a) + g(a \text{ ke } d) + h(a)$$

$$F = 0 + 634 + 70 = 704$$

$$f(n) = g(a) + g(a \text{ ke } b) + h(a)$$

$$F = 0 + 257 + 80 = 337$$

$$f(n) = g(a) + g(b \text{ ke } c) + h(b)$$

$$F = 337 + 198 + 80 = 615$$

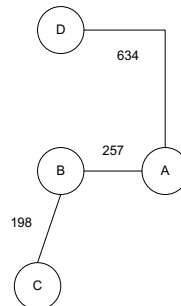

Figure 10. Step Two

$$f(n) = g(a) + g(a \text{ ke } d) + h(a)$$

$$F = 0 + 634 + 70 = 704$$

$$f(n) = g(a) + g(a \text{ ke } b) + h(a)$$

$$F = 0 + 257 + 80 = 337$$

$$f(n) = g(a) + g(b \text{ ke } c) + h(b)$$

$$F = 337 + 198 + 80 = 615$$

The second step of the calculation of A-D nodes is (704), node A-D (337), node B-C (615) Because the first step of the lowest cost is on node A-B, so the comparison is now to node A-D and node B-C the lowest cost on node B-C is 615.

Third, the lowest financing C, (615) being the Best Node, carried out closed transfer, succession C opened with E entered into OPEN.

Closed: A,B,C Open: E

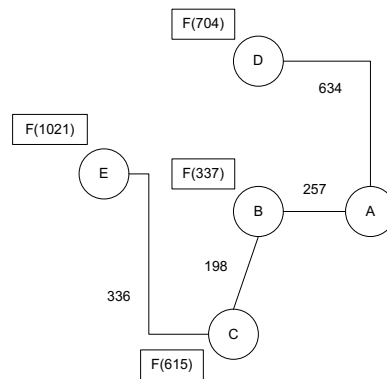

Figure 11. Step Three

Step Four, D lowest financing, (704), being the Best Node, carried out the closed transfer, the successor opened is G inserted into the OPEN.

Closed : A,B,C,D Open: G

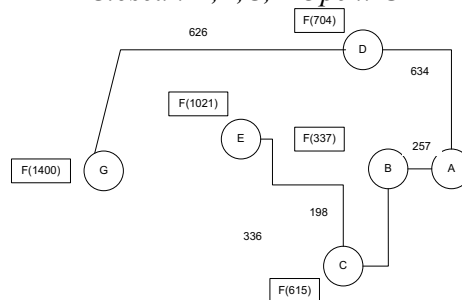

Figure.12 Step Four

Step Five, E lowest financing (1021) to Be Best Node, closed transfer, opening success is F and G are inserted into OPEN.

Closed: A,B,C,D,E Open: F,G

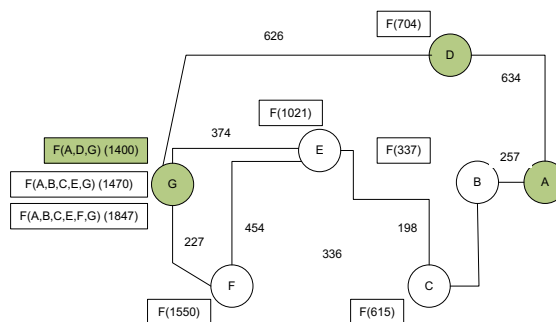

Figure13. Step Five

Next, the G with the smallest financing (1400) is chosen to be Best Node, because it is the same as GOAL, meaning that the exit has been obtained. From A to G because it is concluded to have only one parent and concluded to have cost information (g). The search is best, with the results of the A-D-G route 1400 meters away.

3.2. System Implementation

The implementation of this system stages the design of the system using the A* algorithm. At this stage, the program's testing uses hardware and software that has been conveyed at the point of non-functional needs.

3.3. Software Implementation Results

Here are some software implementation results based on the application that has been created.

1. Login Page is a merchant page also the user is intended to login in the account that has. As for the appearance, as follows.



Figure14. Login Page

2. Home

This main page has 2 types: the main page of the app used for mobile merchants and users, and the admin page that admins only access.

3. A* Algorithm Application Display Results

In the application view, A* algorithm can provide the shortest route between the distance of the traveling merchant and the buyer's distance so that the buyer can find the location of the traveling merchant appropriately. After searching the traveling merchant location, there is a recommended path that will be passed the closest distance between the traveling merchant and the buyer.

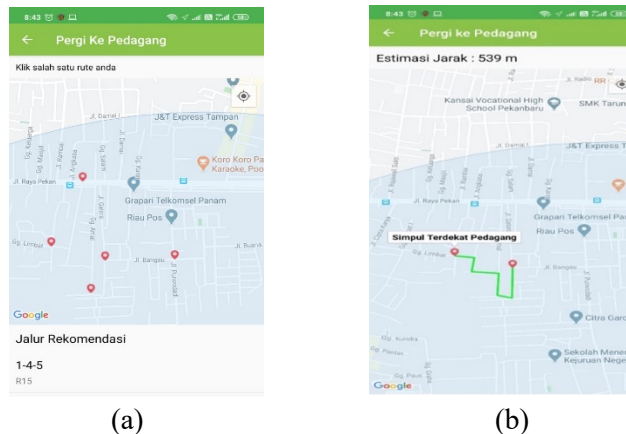

Figure 15. (a) Recommended Line View (b) Nearest Node Trader

4. Merchant List Form

On the merchant list form, traders can apply for registration to become an online mobile merchant so that the user's application can read it. Once the trader registers through the application by filling out the available form then can confirm.



Figure 16. Merchant Registration Form

5. Search Form

The search view can be done by the user to search for environment traders listed on the application. Here is the result.

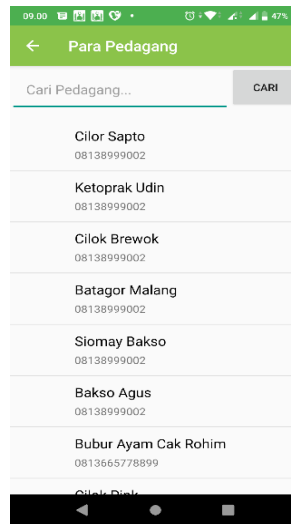

Figure 17. Search Views

3.4. Test Results

Based on the results of manual calculation of the nearest path passing through vertex A-D-G. The desired result data is achieved based on the experiments performed. The following is the test result of A* algorithm method with search process through comparison of path data. The next test conducted is testing in the form of a comparison of paths resulting from calculations using the A* algorithm and the application of A* Algorithm contained in the mobile merchant search application. Testing was conducted from vertex A to Vertex G. Based on the results of manual calculation of the nearest path passing through vertex A-D-G.

1. Testing Techniques

This test uses black box technique, it is testing against a system built whether all goes well or not.

Table 2. Goal Timeliness Accuracy Testing

Test (A-D-G)	A	B	C	D	E	F
1	1400	0	240	1600	0	360
2	1410	10	260	1620	20	420
3	1410	10	260	1630	30	460
4	1430	30	300	1620	20	420
5	1400	0	240	1650	50	490
6	1410	10	260	1660	60	500

7	1410	10	260	1640	40	470
8	1400	0	240	1630	30	460
9	1420	20	280	1620	20	420
10	1410	10	260	1610	10	400
Total		100			280	

Description:

A: Unhindered Testing (vertex(A,G))

B: Destination Position Error (vertex(A,G))

C: Unhindered Time Achievement(s)

D: Barrier Testing (vertex(A,G))

E: Destination Position Error (vertex(A,G))

F: Time Achievement with Obstacle(s)

Table 2 shows the precision test results when performing the search to reach the destination point. The average obtained from the error reaches the goal when without using obstacles, namely :

$$x = \text{Average}/(\text{Total Test}) = 100/10 = 10$$

The average obtained from the error reaches the goal when using obstacles, namely:

$$x = \text{Average}/(\text{Total Test}) = 280/10 = 28$$

From the results obtained, reaching the destination point only shifts 10 m from a distance without the use of obstacles. When applying obstacles, the average shift is 20-30 m from a distance.

4. CONCLUSION

The desired result data is achieved based on the experiments performed. All system menus in the admin can run fine so that it can be concluded that all system menus can run well with buyer parameters can more easily access the seller's location information up to 80%, the results of filling data per menu contained in the application run with smooth without constraints, all data can be stored according to the inputted data, and get results according to functional and non-functional needs, the use of the A* method is also done to find traders whose location is closest to the user's location and the results can display the nearest merchant, this research provides suggestions for further development expected features are displayed more complete. As with online delivery and ordering information, merchants can efficiently directly deliver orders to buyer locations, and it is expected that in the future, it can be developed into a mobile-based application with platforms other than android, such as IOS.

ACKNOWLEDGEMENTS

The author thanked STMIK Amik Riau for providing support and assistance to this research so that it can run well.

REFERENCES

- [1] M. Yunus and A. Insani, "GOVERNANCE OF STREET VENDORS IN MAKASSAR CITY (Epe Banana Trader case study' at Losari Beach)," *J. Anal. Be wise. and Public Service*, vol. 3, no. 1, pp. 23–36, 2017.
- [2] H.M. Prayoga, M. Nasir, and H. Syaputra, "Implementation of A Star Algorithm And Shooting Star In The Search for the Shortest Route mapping Hospitals In Palembang Based On Android," *J. Binadarma*, pp. 1-10, 2017.
- [3] W. Widodo and I. Ahmad, "Application of A Star Algorithm (A*) in Android-Based Maze Adventure Game," *Khazanah Inform. A. Complicit Science. and Inform.*, vol. 3, no. 2, p. 57, 2018.
- [4] S. Purnama, D. A. Megawaty, and Y. Fernando, "Application of A Star Algorithm For Determining The Closest Distance of Culinary Tourism in Bandarlampung City," *J. Teknoinfo*, vol. 12, no. 1, p. 28, 2018.
- [5] N. Azizah and D. Mahendra, "Geolocation with Dijkstra Method to Determine the Shortest

- Path of Worship Location," *J. Sist. Inf. Business*, vol. 7, no. 2, p. 96, 2017.
- [6] K. Setiawan, S. Supriyadin, I. Santoso, and R. Buana, "Calculating the Shortest Route Using Algorithm A* With Euclidean Distance Function," *Semin. Nas. Teknol. Inf. communal.*, vol. 2018, no. ISSN: 2089-9815, pp. 70–79, 2018.
- [7] Y. Syukriah, F. Falahah, and H. Solihin, "Application of algorithm a* (star) to Find the Fastest Route with Obstacles," *Semin. Nas. Telekomun. and Inform.*, no. 1, pp. 219–224, 2016.
- [8] D. Hermanto and S. Dermawan, "Application of A-Star Algorithm as The Shortest Route Finder on Hexapod Robots," *J. Nas. Tech. Electro*, vol. 7, no. 2, p. 122, 2018.
- [9] H. Hermawan and H. Setiyani, "IMPLEMENTATION OF A-STAR ALGORITHM IN UNITY-BASED ROGUELIKE COMPUTER GAMES A-Star Algorithm Implementation On Roguelike Computer Game Based On Unity," no. 1, pp. 111–120, 2019.
- [10] U. Hairah and E. Budiman, "Night Market Information Media In Samarinda City," vol. 9, no. April, pp. 9–16, 2017.

BIOGRAPHY OF AUTHORS



Istithoatun Kholishoh is a student in Informatics Engineering of STMIK Amik Riau since 2016. She works at PT Application Creative Indonesia engaged in the field of digital transactions since 2019. Her current research interests include mobile computing.



Ir Mardainis, M.Kom obtained Bachelor Degree in Informatics Engineering from STMIK Amik Riau and obtained Master Degree in Information Technology UPI UPTK Padang. he serves as a lecturer at STMIK Amik Riau since 2008 Her current research interests include security system and mobile computing.



Susandri, S.Kom, M.Kom obtained Bachelor he holds a Computer Engineering STMIK UPI YPTK Padang and S2 Information Technology UPI YPTK Padang. he serves as the 1st deputy chairman of student affairs at STMIK Amik Riau. Her current research interests include mobile computing.



Khusaeri Andesa, S.Kom, M.Kom obtained a Bachelor of Informatics from STMIK Amik Riau and a Masters in Informatics Engineering from UPI YPTK Padang. Previously served as Head of Sisfo at STMIK Amik Riau. Her current research interests include network and web programming.