

Title	Cold Model Test of a DTL with Transition from 47 to 2 - Mode Acceleration
Author(s)	Ikeda, Kazumi; Kan, Taro; Yoshizawa, Kunio; Yokobori, Hitoshi; Hirota, Jitsuya; Iwashita, Yoshihisa; Okamoto, Hiromi; Noda, Akira; Inoue, Makoto
Citation	Bulletin of the Institute for Chemical Research, Kyoto University (1993), 71(1): 26-36
Issue Date	1993-03-31
URL	http://hdl.handle.net/2433/77493
Right	
Type	Departmental Bulletin Paper
Textversion	publisher

Cold Model Test of a DTL with Transition from 4π to 2π -Mode Acceleration

Kazumi IKEDA*, Taro KAN*, Kunio YOSHIKAWA*,
Hitoshi YOKOBORI*, Jitsuya HIROTA*, Yoshihisa IWASHITA**,
Hiromi OKAMOTO**, Akira NODA** and Makoto INOUE**

Received February 9, 1993

A cold model test has been carried out using a constant-velocity model for the investigation of a DTL with transition from 4π to 2π -mode acceleration. The model cavity consists of sixteen cells which are resonant at 425 MHz and correspond to a proton energy of about 2 MeV. On-axis electric field distributions were measured with the Bead Perturbation Method. The measurements reveal that a difference of about 5% exists between the average fields in the 4π and 2π -mode cell. Field stabilization by post coupler is improved by using slightly different spacings between the drift tube and the post coupler for the 4π and 2π -mode cells. The extra stem on each drift tube improves the field stability when the stems are installed in line each other. The stability, however, is not improved when the stems are installed cross-wise each other.

KEY WORDS : Proton Linac/ Alvarez DTL/ 4π -mode Acceleration/ Post Coupler/ Field Stabilization/ Single Stem/ Double Stem

1. INTRODUCTION

A design study of a 10 MeV proton linac for multi-purpose use has been carried on since April, 1990, in cooperation of the Institute for Chemical Research of Kyoto Univ. and Mitsubishi Atomic Power Industries, Inc.. It is intended in this study to investigate an optimum combination of a four vane RFQ linac and DTLs of 4π and 2π -mode acceleration whose operating frequency is 425 MHz. The transition energy from the RFQ to the DTL of 4π -mode acceleration is tentatively fixed at 1 MeV so that the fabrication and adjustment of the RFQ may be facilitated. A cold model test of the RFQ indicated that good field stabilization would be achievable by magnetic coupling between the quadrants.¹⁾

The transition energy from the 4π to 2π -mode acceleration in the DTL is tentatively fixed at 2 MeV. The DTL is designed to be a single-tank structure because of the simplicity. A cold model test was planned for the investigation of the DTL with transition from 4π to 2π -mode acceleration.

Drift tubes supported by two stems were considered for cryogenic DTLs to reduce vibration and to minimize drift tube deflection. It was reported that a DTL with double stem 180° apart should be inherently more stable against tuning errors than a similar structure with single stem.²⁾ It is interesting to examine how the double stem improves the field stability of the DTL with

* 池田一三, 菅 太郎, 吉澤邦雄, 横堀 仁, 弘田実弥 : Mitsubishi Atomic Power Industries, Inc.

** 岩下芳久, 岡本宏巳, 野田 章, 井上 信 : Nuclear Science Research Facility, Institute for Chemical Research, Kyoto University.

transition from 4π to 2π -mode acceleration.

It is also intended to examine the field stabilization by post coupler. The post coupler is in principle a quarter-wave resonator. Empirical observations identify a "safe" operating range for field stabilization³⁾. The model cavity is fabricated so as to satisfy this operating range.

2. STRUCTURE OF MODEL CAVITY

The structure of the constant-velocity model cavity is shown in Fig. 1. The cavity consists of 16 cells whose lengths correspond to the proton energy of about 2 MeV; 5 cells (each 90.0 mm long) for 4π -mode acceleration, 1 cell (67.5 mm long) for transition from 4π to 2π -mode acceleration and 10 cells (each 45.0 mm long) for 2π -mode acceleration. The equivalent inner diameter and length of the cavity are 430.0 and 967.5 mm respectively. The diameter of the drift tube (DT) and bore hole are 80.0 and 10.0 mm respectively. The gap length between the DTs is determined by the SUPERFISH calculation to bring the resonant frequency at 425 MHz.

The DT can be supported by either single or double stem 180° apart. The diameter of the stem is 15 mm. The half DT on each end plate can be moved to detune the end cell. A post coupler (PC) can be installed opposite each DT of the 4π -mode cell and transition cell, and opposite every other DT of the 2π -mode cell. Successive PCs are located at the alternate side of the tank. The diameter of the PC is also 15 mm. The model cavity, including the PC, are made of aluminum alloy (5052). Photo. 1 and 2 shows the inside of the cavity under assembling and the outside of the cavity after completion.

Fig. 2 shows measured deviations of the bore center of each DT from the beam axis in horizontal and vertical directions. The target accuracy of the DT alignment is ± 0.05 mm in both directions which are achieved as follows:

- Horizontal x : -0.017 ± 0.023 mm
- Vertical y : -0.015 ± 0.029 mm
- Radial r : 0.023 ± 0.025 mm

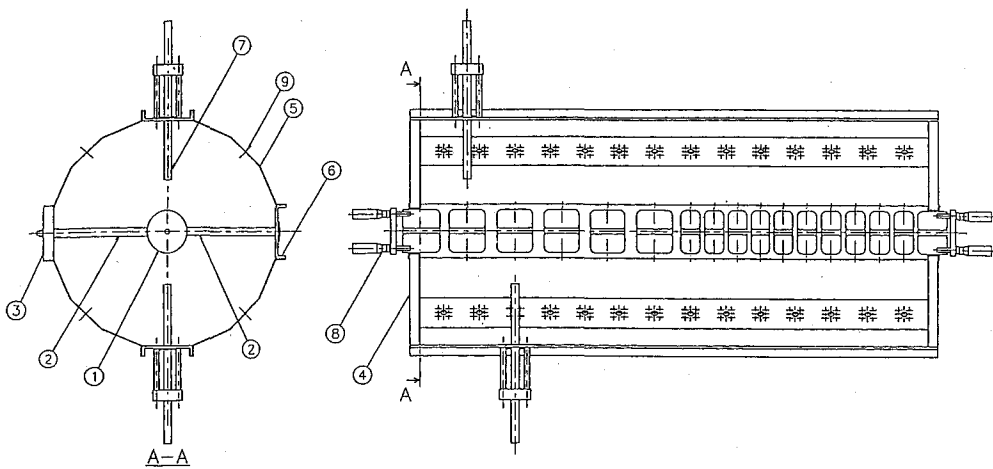

Fig. 1. Structure of the model cavity.

- | | | |
|--------------|---------------|----------------------------|
| 1 Drift tube | 4 End plate | 7 Post coupler |
| 2 Stem | 5 Cavity wall | 8 End cell detuning device |
| 3 Garter | 6 Channel | 9 Measurement hole |

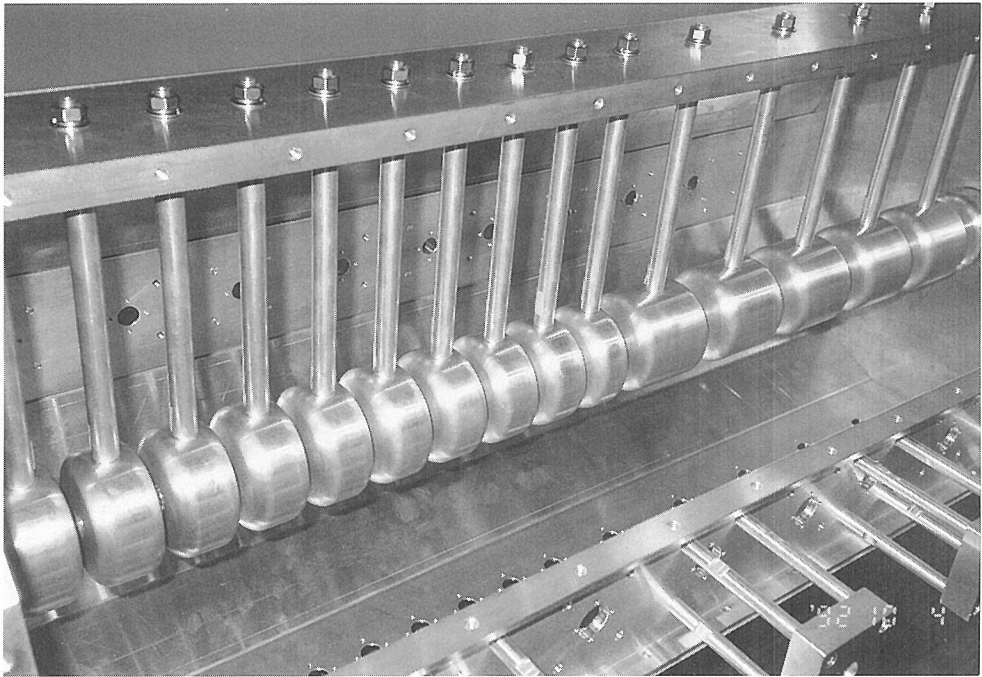

Photo. 1. Inside of the model cavity under assembling.

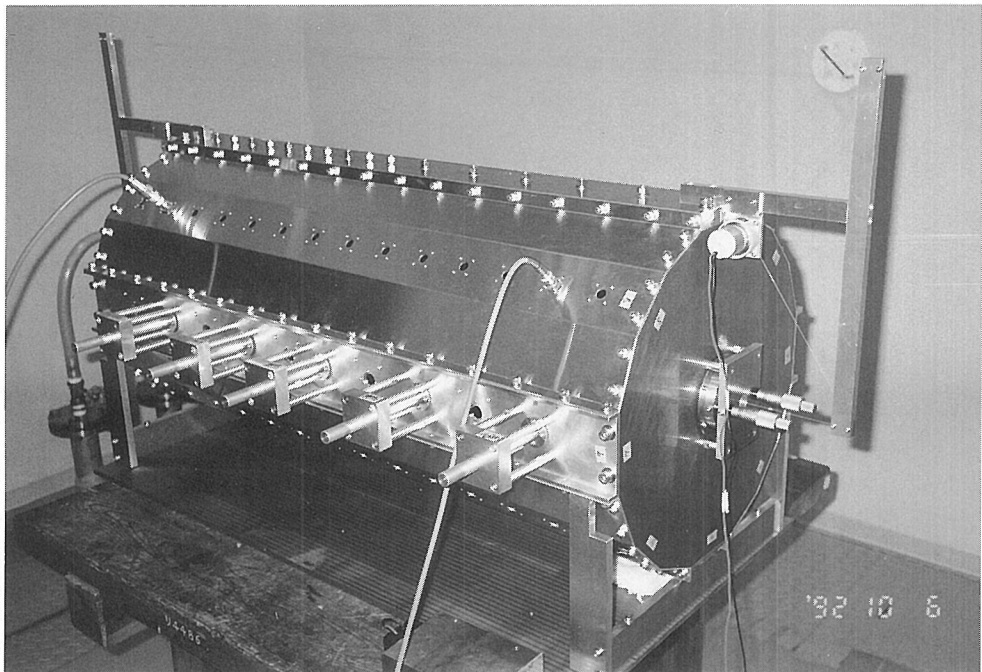

Photo. 2. Outside of the model cavity after completion.

Cold Model Test of a DTL with Transition from 4π to 2π -Mode Acceleration

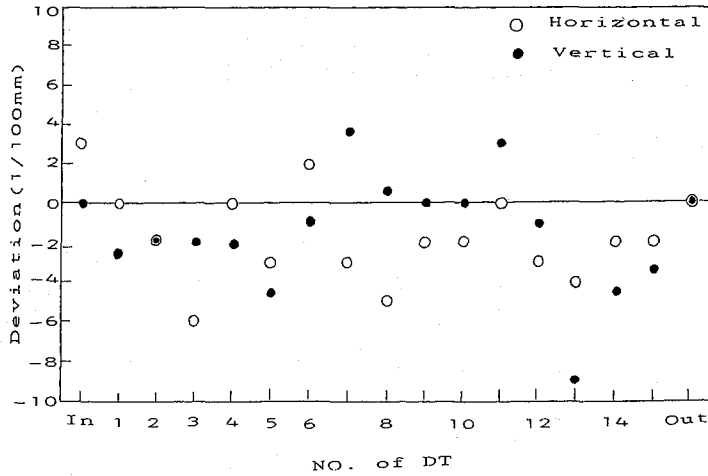

Fig. 2. Deviation of the bore center from the beam axis in the model with single stem.

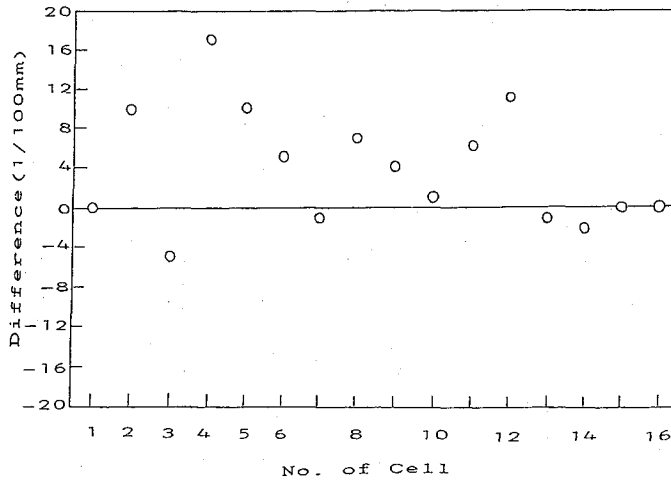

Fig. 3. Difference of the gap length from the design value in the model with single stem.

Fig. 3 shows differences of the measured gap lengths from the design values which are 21.82, 15.36 and 8.54 mm for the 4π -mode, the transition and the 2π -mode cell respectively. The averaged value of these differences is 0.04 ± 0.06 mm. It is suspected that the present measurement method of the gap length tends to give a larger value than the real one.

The Q value of the cavity is measured to be 2.5×10^4 and estimated with SUPERFISH to be 4.57×10^4 including the effects of the stems and end plates. Considering the difference of the electric conductivities between copper and aluminum alloy, the calculated value is corrected to 2.70×10^4 .

3. RESONANT FREQUENCY AND FIELD DISTRIBUTION

Resonant frequencies for various modes were measured on the model cavity with single

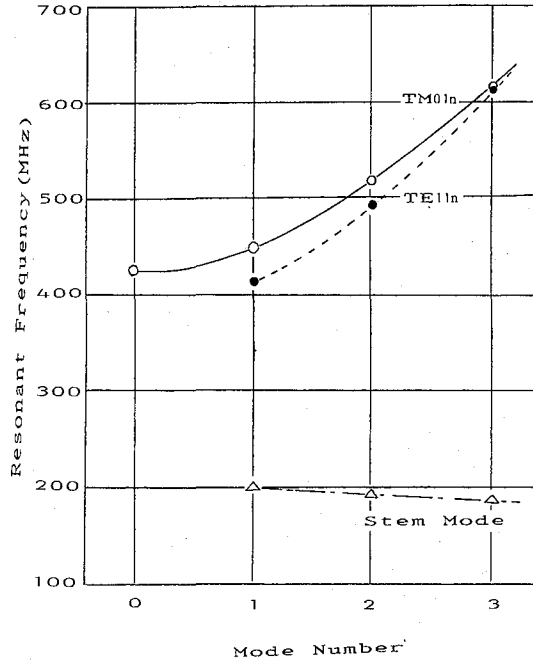

Fig. 4. Dispersion curves in the cavity with single stem.

stem. Dispersion curves for these modes are shown in Fig. 4. The measured resonant frequency is 425.613 MHz for the TM010 mode which agrees quite well with the calculated one. The measured resonant frequency is 449.375 MHz for the TM011 mode and the frequency difference between the TM010 and TM011 mode is 23.760 MHz which is considerably large. The larger the frequency difference, the harder it is to achieve an appreciable admixture of the

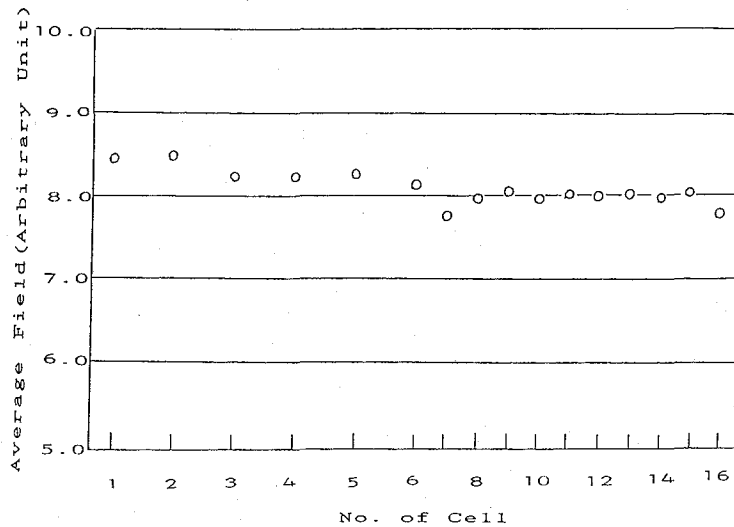

Fig. 5. Distribution of the average electric field in the cavity with single stem.

Cold Model Test of a DTL with Transition from 4π to 2π -Mode Acceleration

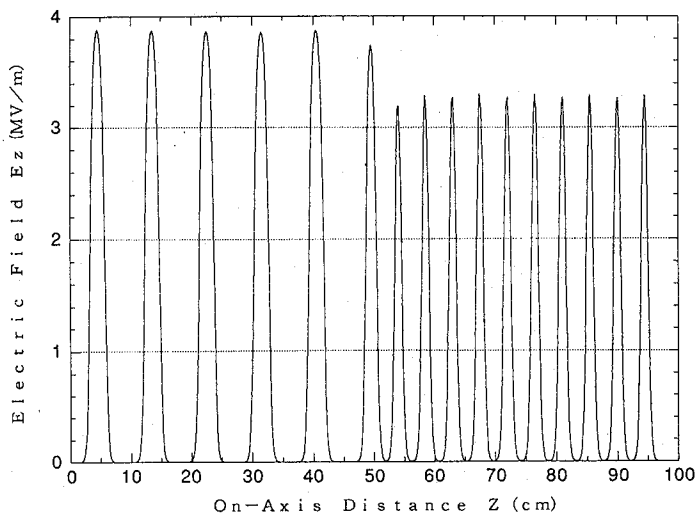

Fig. 6. Distribution of the electric field calculated with SUPERFISH.

TM011 with the TM010 mode, and therefore, the more stable the field distribution. This large frequency difference, however, is only owing to the shortness of the model cavity. The stem modes distribute in a range from about 200 MHz to 140 MHz on the cavity with single stem.

The on-axis electric field distribution was measured with the Bead Perturbation Method. An aluminum cylindrical bead of 3.0 mm diameter and 1.5 mm length was used. It was confirmed that the length of the bead was short enough to measure the fine field distribution in the gap. Fig. 5 shows the distribution of the average electric field (integrated electric field divided by the cell length) of each cell in the cavity with single stem. The average fields in the 4π and 2π -mode cells are uniform within $\pm 1.6\%$ and $\pm 1.3\%$ respectively, except for the transition cell.

The averaged electric field in the 4π -mode cells is 5% larger than that in the 2π -mode cells. Fig. 6 shows the distribution of the electric field calculated with SUPERFISH. This distribution gives the difference of 4% which agrees satisfactorily with the measured one.

4. FIELD STABILIZATION BY PC

Fig. 7 shows the shifts of resonant frequencies for the TM01 n modes by 10 PCs which are inserted with the same spacing between DT and PC each other. These modes were identified by the on-axis field distributions. This figure suggests that PC may be effective in a range less than 20 mm of the spacing between DT and PC.

The field stabilization was investigated as follows: Two field distributions for different detuning of the end cell are carried out: For the first measurement, decreasing the first gap (cell-1) lowers the TM010 mode frequency by Δf and increasing the last gap (cell-16) restores the frequency. This type of the detuning tends to "tilt" the field towards the cell-1, resulting in the higher field in the cell-1 and lower field in the cell-16. The second measurement corresponds to the opposite sign perturbation to both the end cells, which tends to tilt the field opposite direction.

A distortion parameter, D_s , which indicates the effectiveness of field stabilization by PC is defined with similarity to $D_x^{(4)}$ as follows:

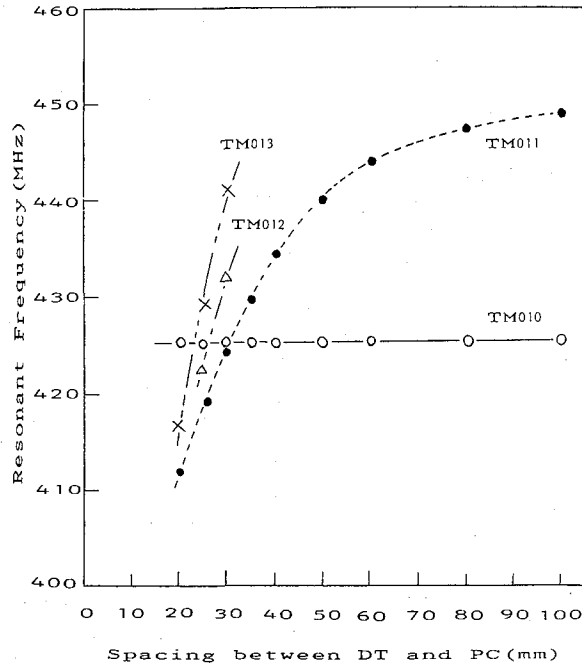

Fig. 7. Shifts of the resonant frequencies for TM_{01n} modes by PC.

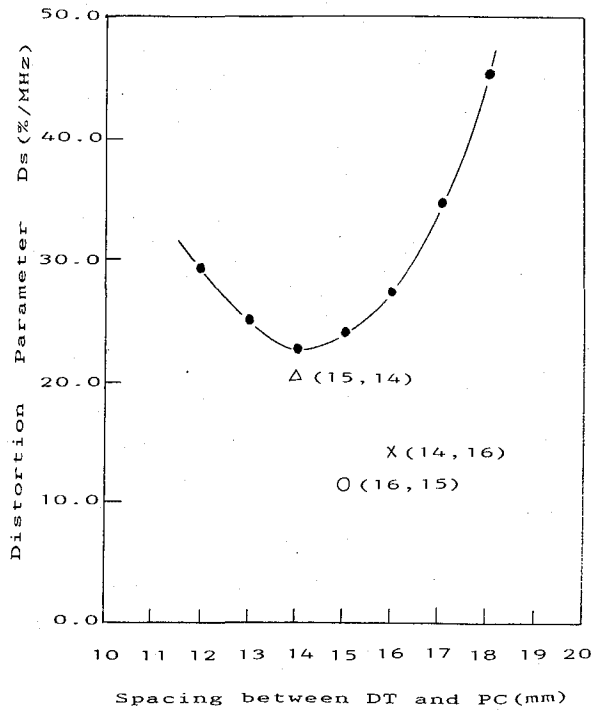

Fig. 8. Distortion parameter vs. spacing between DT and PC. (S_1, S_2) : S_1 and S_2 are the spacing in 4π and 2π -mode cell respectively.

$$Ds = \sum_n |E_{n,s}^+ - E_{n,s}^-| / (E_{n,s}^+ + E_{n,s}^-) \cdot \Delta f \times 100 \quad (\%) \quad (1)$$

where $E_{n,s}^+$ and $E_{n,s}^-$ are the on-axis electric field of the cell- n in the first and second measurement for the spacing, s , between DT and PC. Fig. 8 shows a plot as a function of s . As seen in this figure, a smaller Ds is obtainable if the slightly different spacing is used for the 4π and 2π -mode cell.

5. DOUBLE STEM AND TILT SENSITIVITY

The dispersion curves shown in Fig. 9 are those for the cavity with double stem. The measured resonant frequencies are 426.432 MHz for the TM010 and 477.617 MHz for the TM011 mode in the cavity with double stem (in line). The extra stem on each DT increases the TM010 mode frequency by only 0.819 MHz, but increases the TM011 mode frequency by 28.244 MHz. The frequency difference between the TM010 and TM011 mode is more than two times larger with double stem (in line) in comparison with single stem.

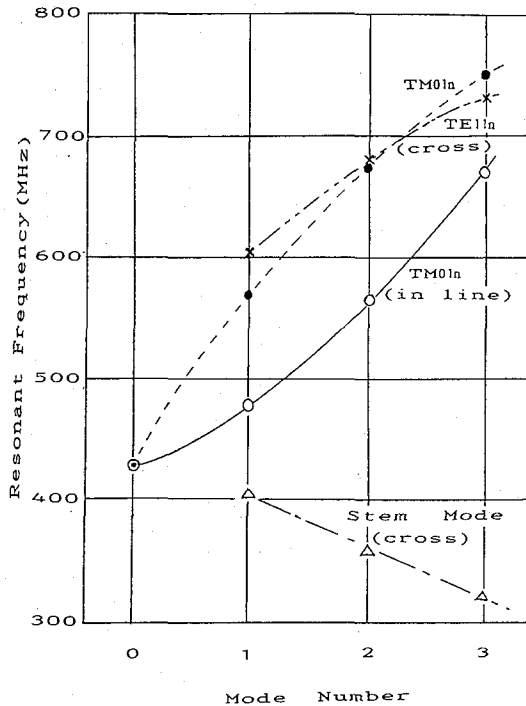

Fig. 9. Dispersion curves in the cavity with double stem.

Table 1. Fitting results of the TM01 n frequencies to second order polynomials.

	Single Stem	Double Stem (in line)
C_0	425.613 MHz	426.430 MHz
C_1	1.448	32.685
C_2	22.312	18.505

$$\text{TM01}n \text{ frequency } f(\text{MHz}) = C_0 + C_1n + C_2n^2 \quad (n=0, 1, 2)$$

Table 1 gives the fitting results of the resonant frequency (f MHz) for the $TM01n$ mode ($n=0, 1, 2$) to second order polynomials of n for the cavity with single and double stem (in line). The first order coefficient C_1 for double stem (in line) is much larger than that for single stem. Therefore, a DTL with double stem (in line) should be more advantageous than that with single stem for a longer cavity at this energy region.

The results calculated with MAFIA⁵⁾ are shown in Fig. 10 and a typical one-cell geometry used in these calculations is shown in Fig. 11. Only the zero modes and $STEM\pi$ mode are calculated with this geometry. The zero modes for TE passband are not seen in a real finite

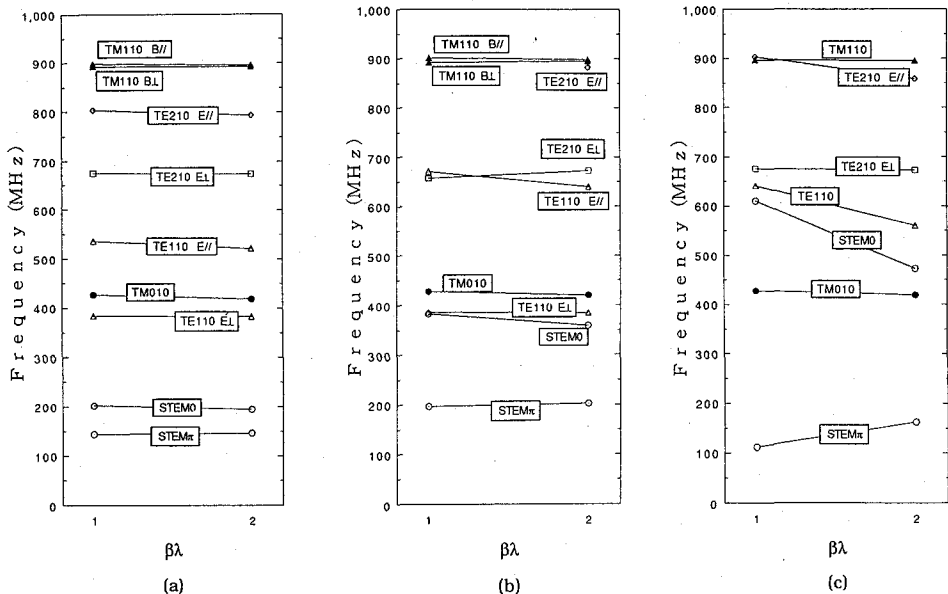

Fig. 10. Results calculated with MAFIA. (a) Single stem, (b) Double stem (in line) and (c) Double stem (cross).

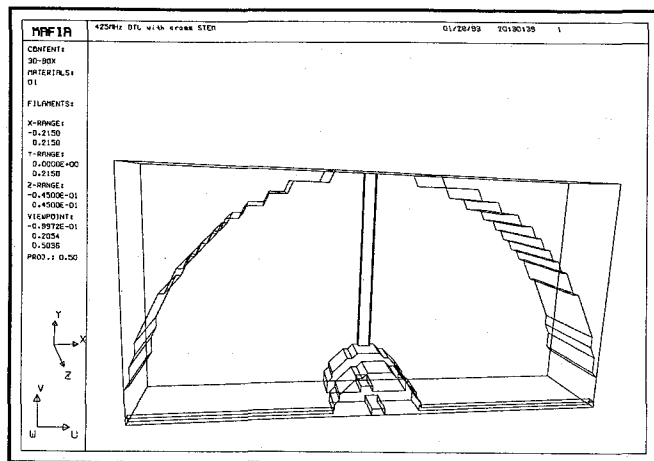

Fig. 11. Typical mesh geometry used in the MAFIA calculation.

length cavity. Fig. 10-a shows the results for the cavity with single stem and Fig. 10-b and c show those with double stem (in line and cross). Because the two radial directions x and y are identical in the calculation for the cavity with double stem (cross), the dipole modes perturbed by the stem are degenerated.

The frequency dependence on cell length is not large in these geometries except for the stem and TE modes in the cavity with double stem (cross). The STEM0 mode in the cavity with single stem has the frequency much lower than the TM010 and that with double stem (in line) has the frequency closer to the TM010 mode. The STEM0 mode in the cavity with double stem (cross) has the frequency higher than the TM010 and the stem-mode passband overlaps the TM010 mode in both cell lengths. In this stem geometry, it is supposed that the STEM0 mode has a frequency lower than the TM010 in longer cell geometries.

The effectiveness of the extra stem on the field stabilization was investigated by using tilt sensitivity (TS)²⁾. TS is defined as follows:

$$TS = (E_n^+ - E_n^-) / (E_n^+ + E_n^-) \cdot \Delta f \times 100 \quad (\%) \quad (2)$$

where E_n^+ and E_n^- are the on-axis electric field of the cell- n in the first and second measurement as defined for Ds. Fig. 12 shows three TS measurements; one with single stem and two with double stem 180° apart. The TS slope for the cavity with single stem and double stem (in line) are -38 and $-12\%/MHz/m$ respectively. The extra stem on each DT results in an almost threefold reduction in the slope when the stem are installed in line each other. This higher stability is consistent with the observed large increase in the TM011 mode frequency. The TS behaves quite differently when the stems are installed cross-wise as seen in Fig. 12: The TS slope for the 4π -mode cells is smaller than that for the 2π -mode cells, and almost equal to the TS slope for the cavity with double stem (in line) although opposite in the sign. This fact indicates

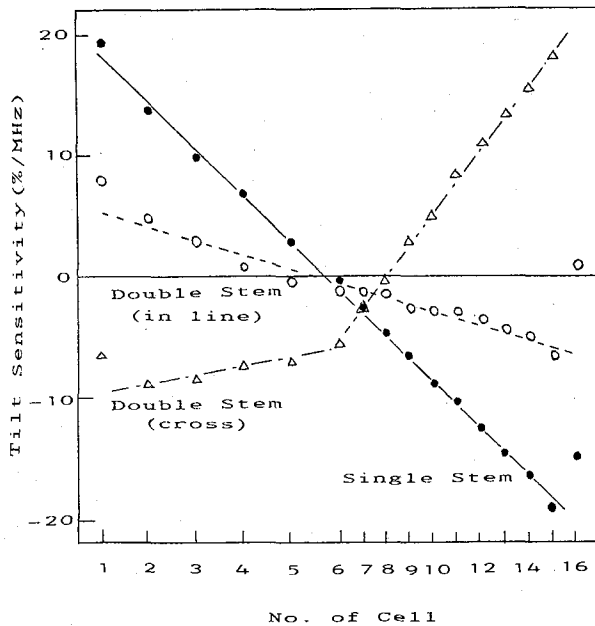

Fig. 12. Tilt sensitivities for the cavities with single and double stem.

that a DTL with double stem (cross) may be advantageous in an energy region higher than 8 MeV.

6. CONCLUSION

The resonant frequency measured for the TM010 mode agrees quite well with the value calculated with SUPERFISH. The average field difference of about 5% is observed between the 4π and 2π -mode cell, which agrees satisfactorily with the SUPERFISH calculation.

As for the field stabilization by PC, the use of slightly different spacings between DT and PC in the 4π and 2π -mode cells results in an about twofold reduction in the distortion parameter.

The extra stem on each DT improves the field stability resulting in an almost threefold reduction in the TS slope when the stems are installed in line each other. This higher stability is consistent with the almost twofold increase in the frequency difference between the TM010 and TM011 mode. The stability is not improved when the stems are installed cross-wise each other. A DTL with double stem (cross) may be advantageous in an energy region higher than 8 MeV.

ACKNOWLEDGEMENT

Computation time for the MAFIA calculation was provided by the Supercomputer Laboratory, Institute for Chemical Research, Kyoto University.

REFERENCES

- (1) K. Ikeda et al., "Cold Model Test of A Four Vane RFQ for Multi-Purpose Use Linac", *Bull. Inst. Chem. Res., Kyoto Univ.*, **70**, 99 (1992).
- (2) J.H. Billen, "Field Stability in Two-Stem Drift-Tube Linacs", Mo3-35, *1988 Linac Conf. at CEBAF, CEBAF-Report 89-001*, 125 (1989).
- (3) J.H. Billen, "Survey of Drift Tube Linacs with Post Couplers", *AT-1: 84-74 LANL memorandum* (1984).
- (4) M. Sawamura and H. Takekoshi, "Field Stabilization of the Alvarez Linac by Post coupler", *Bull. Inst. Chem. Res., Kyoto Univ.*, **63**, 9 (1985).
- (5) The Mafia Collaboration, "MAFIA USER GUIDE", March 16, 1988.