

| | |
|-------------|--|
| Title | Mechanical Design of 33.3 MHz 4-Rod Heavy Ion RFQ Cavity |
| Author(s) | Fujisawa, Hiroshi; Tamada, Masayuki; Katagiri, Toshihiko; Iwashita, Yoshihisa; Takekoshi, Hidekuni |
| Citation | Bulletin of the Institute for Chemical Research, Kyoto University (1992), 70(1): 28-36 |
| Issue Date | 1992-03-30 |
| URL | http://hdl.handle.net/2433/77435 |
| Right | |
| Type | Departmental Bulletin Paper |
| Textversion | publisher |

Mechanical Design of 33.3 MHz 4-Rod Heavy Ion RFQ Cavity

Hiroshi FUJISAWA*, Masayuki TAMADA*, Toshihiko KATAGIRI*,
Yoshihisa IWASHITA**, and Hidekuni TAKEKOSHI**

Received February 8, 1992

A full-scale 33.3 MHz heavy ion RFQ cavity has been designed and constructed. The cavity is made of oxygen-free copper and its length and inner diameter are 2360 mm and 600 mm, respectively. 4-Rod type RFQ assembly with un-modulated electrodes has been installed in the cavity. The measured resonant frequency is 33.0527 MHz and measured un-loaded Q -value is approximately 5000. The vacuum level is about 5.0 E^{-7} torr when RF power is off.

KEY WORDS : RFQ/4-ROD RFQ/Heavy Ion Linac/RF Cavity/

1. DESIGN OUTLINE

There are many important considerations to be given before we can embark on designing the cavity and it always true that many things are interwoven and interrelated in real life that the God only allows us to make efforts for compromises. The following is a list of general criterion that we considered important when designing our RFQ cavity :

1. Electrode length is around 2 m.
2. Total length of cavity is around 2 m.
3. Cavity diameter is less than 90 cm.
4. Easy maintenance and better accessibility.
5. Temperature rise of cooling water is less than 10 °C.
6. Resonant frequency tuner is capable to compensate frequency drift caused by thermal expansion of RFQ structure.
7. Withhold high power cw RF.
8. Good RF contact between the cavity and RFQ assembly.
9. 50 mm accuracy in electrode assembly.
10. Don't allow RF or X-ray leak to outside cavity.
11. Don't allow any local heating by RF.
12. Protect o-rings from RF.
13. Vacuum level should be better than 5.0 E^{-7} torr when RF is off and 1.0 E^{-6} torr when RF is on.

* 藤沢 博, 玉田将之, 片桐俊彦 : Nissin Electric Co., Ltd., Kyoto.

** 岩下芳久, 竹腰秀邦 : Institute for Chemical Research, Kyoto University, Kyoto.

14. Overall cost-performance.

No explanation is given in the list of why and where those numbers are coming from, however, the most of items originate from prerequisites we must satisfy for industry uses. Those basics limit the fundamental design of what we can do and what we should not.

General feature of our RFQ linac is summarized in the reference¹⁾ so we give here only a brief outline. A conservative approach should be given to cooling consideration because this cavity is going to be operated in high power cw RF. Design is such that more than adequate cooling medium –deionized water in our application– can be allowed to flow in all channels. The beam optics axis is not the center of the tank, but they are eccentric in order to reduce the tank diameter. This results in lowering both the manufacturing cost of cavity and vacuum system requirements. The cavity cannot be made in one piece because of engineering difficulty. It consists of two identical tanks joined together at the center.

2. CAVITY

Fig. 1 is a drawing of and photo. 1 is an exterior view of our RFQ cavity. The total length of the cavity is 2360 mm and inner diameter is 600 mm. The material of the cavity is oxygen-free copper and the thickness of the cavity wall is 35 mm. The cavity – as mentioned earlier – consists of two identical tanks joined together at the middle. Each tank has five ports for a vacuum pump, a view window, a RF power drive, a RF monitor, and a loop-tuner. There are five view windows – one in the center is later used for the beam port– in the end-flange of the cavity. Each tank has four cooling pipes half embedded and silver-brazed in the exterior surface. A portion of the inner surface at the bottom-side of the cavity is machined flat so that the RFQ electrode assembly can be positioned in place and it gets a good electrical contact with the cavity wall. Photo. 2 shows the inner view of the RFQ cavity. A pumping port and a RF drive loop are seen on the left and a loop-tuner and a small port for the RF monitor on the right. Also seen in photo. 2 is the machined-flat surfaces at the bottom of the inner wall.

3. RFQ ELECTRODE ASSEMBLY

Photo. 3 is a view of RFQ electrode assembly installed in the cavity. It consists of three major part: the RFQ electrodes, the electrode supporting posts, and the base plate. The material is all copper – aluminum version of the supporting posts are shown in photo. 3, however, which were made for low RF power testing purpose. The whole assembly is put together using alignment jigs outside the cavity as shown in photo. 4. It was then installed in the cavity and securely fixed to the cavity with four M20 bolts. Assembling and disassembling of the RFQ electrode can be done relatively easily by just two people. The number of the post is six – this means a pair of RFQ electrodes is supported by three posts. The width and thickness of the post are 247 mm and 45 mm, respectively. The beam optics axis is 330 mm above the top surface of the base plate. The posts are evenly spaced by 405 mm from each other. The length of electrode is 2220 mm. The aperture radius is 8.0 mm. RF contact between the tank and the base-plate of the RFQ assembly is made by commercially available

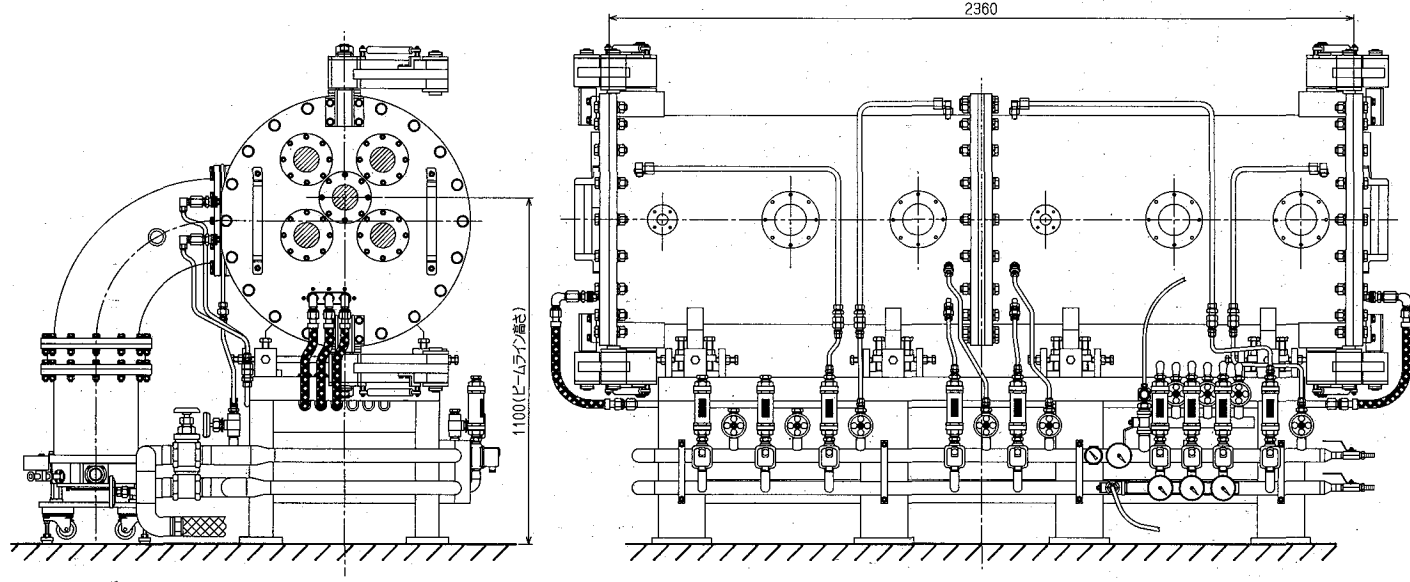

Fig. 1. Exterior drawing of 33.3 MHz RFQ cavity.

Mechanical Design of 33.3 MHz 4-Rod Heavy Ion RFQ Cavity

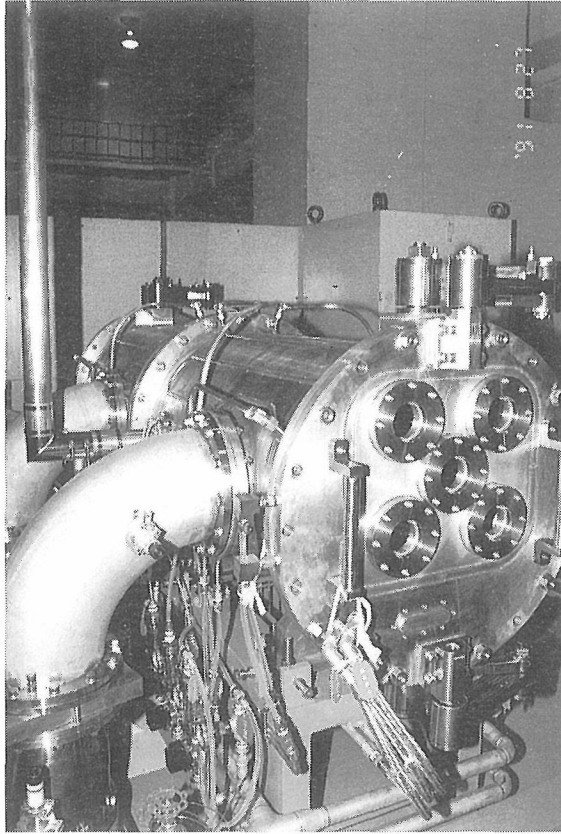

Photo. 1, Exterior view of 33.3 MHz RFQ cavity.

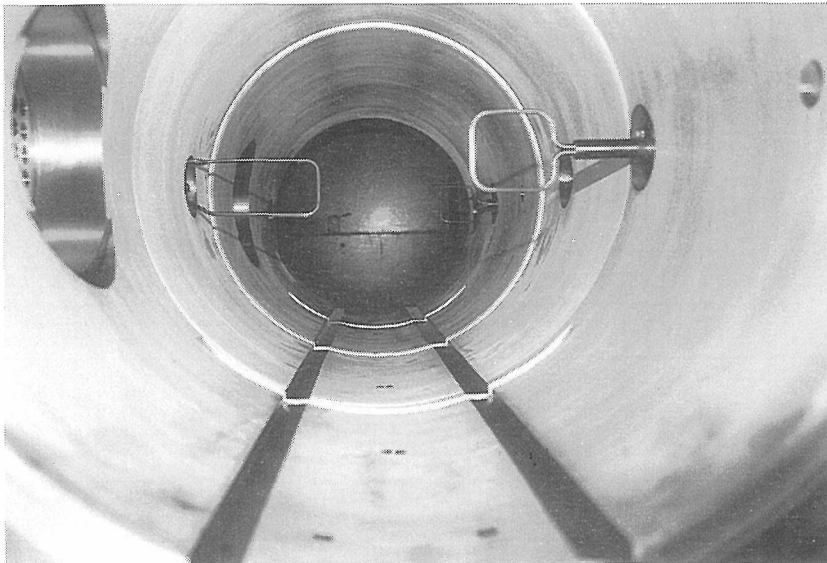

Photo. 2, Interior view of 33.3 MHz RFQ cavity.

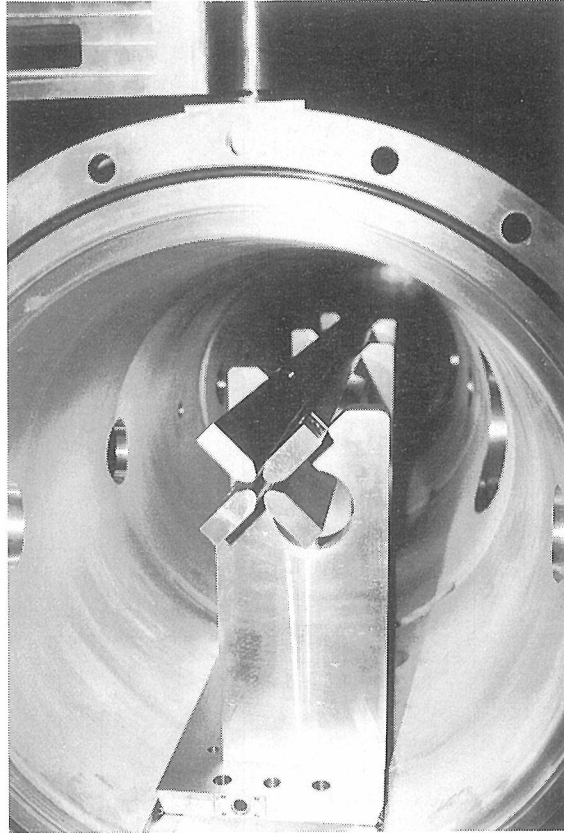

Photo. 3. RFQ electrode assembly installed in the cavity.



Photo. 4. RFQ electrode assembly on the way of getting put together using alignment jigs.

“RF spiral shield”. There are three independent cooling-water channels allocated for the RFQ electrode assembly : two for the electrodes and one for the electrode-supporting post and base plate.

4. COOLING

Cooling is rather uninteresting part of accelerator engineering, nevertheless it is very important because our RFQ cavity is going to be used in high power cw operation. We considered three major parts of our RFQ linac separately : the cavity, the RFQ electrode, and the electrode supporting structure. The major limitation imposed on all the cooling channel is : the temperature rise of cooling medium is less than 10°C and the pressure drop of less than 5 kgf/cm².

The simplest representation of 4 rod RFQ is a parallel resonant circuit²⁾ as shown in fig. 2. Parameters of interest are the resonant frequency f_0 , the unloaded Q -value Q_0 , and the shunt impedance, Z_0 . The shunt impedance is defined as a figure that correlates the inter-electrode voltage of the RFQ to the power spent for exciting the resonator. The magnitude of current flowing C or L can be represented in a simple form³⁾ :

$$I_c \approx I_L = Q_0 I, \text{ where } I = \frac{V_0}{Z_0} \quad (1)$$

Z_0 and Q_0 of our full-scale RFQ cavity are estimated to be about 50 k ohm and 2800 from the results of our 1/3-scale model study, respectively. V_0 is the design inter-electrode voltage, 55 kV. Putting those values in equation (1), I_c becomes 3.1 kA. Also the total power required for exciting the cavity is calculated to be 30.3 kW. Then power dissipated per unit area, P (W/cm²) due to current density, i (A/cm) for copper at frequency, f_0 (MHz) is obtained as follows⁴⁾,

$$P = 1.26 \times 10^{-4} \sqrt{f_0} (i)^2 \quad (\text{W/cm}^2) \quad (2)$$

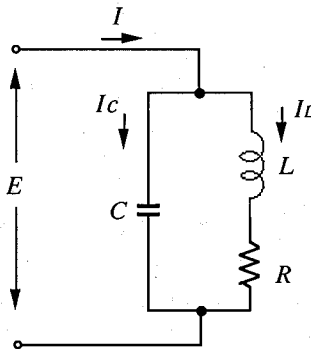

Fig. 2. Equivalent circuit of 4-rod RFQ resonator.

Table 1. Current density, power dissipated, and required cooling water flow rate in the components of 33.3 MHz 4-rod RFQ. $\Delta T=5.0^{\circ}\text{C}$ for this calculation.

| Components | i (A/cm) | P (W/cm ²) | Total power dissipated (kW) | Q (l/min.) |
|------------------------|------------|--------------------------|-----------------------------|--------------|
| Post | 23.0/post | 0.387/post | 3.41 | 9.7 |
| Base | 25.8 | 0.485 | 2.36 | 6.7 |
| Rod electrode | 22.0/piece | 0.352/piece | 2.76/pair | 7.9/pair |
| The rest of the cavity | | | 19.0 | 54.3 |

Note that the current density, i is defined as current divided by cross-sectional circumference length. The current density, power dissipated, and the required water flow rate (l/min) in the electrode supporting post, the RFQ electrode, the base, and the rest part of the cavity – mostly the cavity wall – are computed and the results are given in table 1. In calculating water flow rate we used following expression :

$$W=0.07 Q\Delta T \quad (3)$$

where W is power (kW), Q is flow rate (l/min.), and ΔT is temperature rise of water in $^{\circ}\text{C}$. The results of calculation indicate almost half of power put into the cavity is spent by the RFQ electrode assembly with large portion dissipated in the RFQ electrodes. The results of this calculation is used to determine how such cooling pipes should be implemented in real design to satisfy the criterion given earlier.

5. VACUUM

The vacuum system comprises of two 900 liters/min. oil-rotary pumps and two 2000 liters /s. turbo molecular pumps with a fully-automated control system. A schematics of the vacuum system is shown in fig. 3 and a picture of control system in photo. 5. A typical vacuum level is 5.0 E^{-7} torr when RF is off.

6. CONCLUDING REMARKS

A full-scale 4-rod type RFQ cavity has been constructed as part of the development of a commercial heavy ion implanter. Measured resonant frequency and measured unloaded Q -value are 33.0527 MHz and 5000, respectively. All the necessary preparation has been completed for full power RF tests.

7. ACKNOWLEDGEMENT

The authors would like thank Prof. Makoto Inoue and Prof. Akira Noda of Institute of Chemical Research, Kyoto University for continuing support to proceed with this project. The authors are also grateful for many engineers and technicians who have been involved in this work.

Mechanical Design of 33.3 MHz 4-Rod Heavy Ion RFQ Cavity

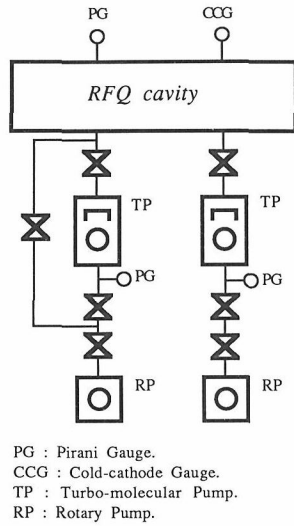

Fig. 3. Schematic drawing of vacuum system for 33.3 MHz RFQ cavity.

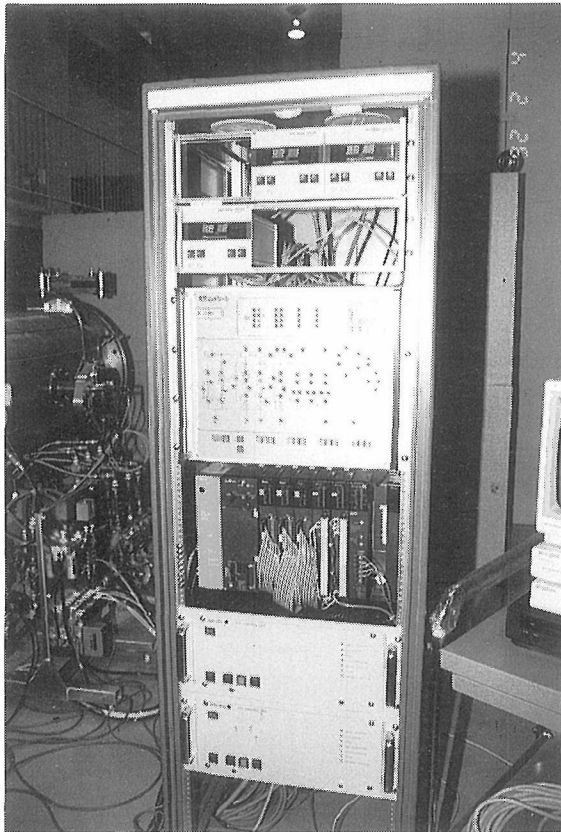

Photo. 5. Vacuum control system for 33.3 MHz RFQ cavity.

REFERENCES

- 1) H. Fujisawa, et al., "Design and Construction of a Heavy Ion RFQ Linac", *Proceedings of the 8th Symposium on Accelerator Science and technology*, p. 122-124 (1991).
- 2) E. L. Ginzton, "Microwave Measurements", McGraw-Hill, New York, Ch. 9 (1975).
- 3) Y. Miyazawa et al., "Mechanical and Thermal Characteristics of Cavities of the RIKEN Variable Frequency Heavy Ion Linear Accelerator", *Report of Rikagaku Kenkyusho*, Vol. 60, No. 2, p. 63-86 (1984).
- 4) S. Uda, "Musen Kohgaku 1", Maruzen Engineer's Library (1964), Ch. 3.2 (1964).