

Title	Position-Sensitive Proportional Counter for High-Energy X Rays
Author(s)	Ito, Shin; Tosaki, Mitsuo; Katano, Rintaro; Isozumi, Yasuhito; Awaya, Yoko
Citation	Bulletin of the Institute for Chemical Research, Kyoto University (1991), 69(1): 43-49
Issue Date	1991-03-30
URL	http://hdl.handle.net/2433/77363
Right	
Type	Departmental Bulletin Paper
Textversion	publisher

Position-Sensitive Proportional Counter for High-Energy X Rays

Shin ITO*, Mitsuo TOSAKI*, Rintaro KATANO**, Yasuhito ISOZUMI**,
and Yoko AWAYA***

Received February 18, 1991

Position-sensitive proportional counter with a single anode wire has been developed for high-energy x-ray detection by utilizing high-pressure counting gas, up to 10 atm. As a position-sensing cathode electrode, the cylindrically-placed backgammon pattern is employed. The position readout has successfully been performed to provide the position resolution of $\sim 100 \mu\text{m}$ for 8 keV x rays with the use of 7 atm. Ar + 30% CH₄ as a counting gas mixture. The design and construction of the counter is presented in detail. Some basic characteristics of the counter performance is given, indicating that further study is needed for the counter operated with high-pressure gas and in the region of limited proportionality.

KEY WORDS: Position Sensitive/Proportional Counter/High-Energy X Rays/High Pressure/Backgammon Pattern/

1. INTRODUCTION

Since powerful synchrotron-radiation facilities, such as Spring 8 (8-GeV Machine) being under construction at Nishi-Harima, may become available in future, there are increasing demands for the development of the position-sensitive proportional counter (PSPC) which is capable of detecting high-energy x rays of 5 - 50 keV with sufficient detection efficiency and position resolution. In order to respond the demands, we have been making the PSPC's by utilizing the high-pressure counting gases, up to 10 atm., of Ar, Kr, and Xe. It is considered that the use of high-pressure gas is advantageous in increasing the detection efficiency, and also in improving the position resolution, because the range of the photo electrons produced in the primary ionization by x rays can be reduced as small as possible¹⁾.

The design of the present PSPC is based on single-wire proportional-chamber principles with position readout from the charge induced on the *cathode* by an electron avalanche at the anode wire. The detector is intended for applications where one-dimensional information is needed. The structure of the position-sensing electrode, *cathode*, is of backgammon type²⁾. The backgammon pattern is printed on a thin film for the photo printing and the film is placed around the anode wire, thus providing the cylindrical counter geometry. In comparison with the flat counter geometry, which is almost the case for PSPC, the advantages of the cylindrical one are as follows: Electric fields in the cylindrical counter hold symmetry around the anode, having the well-

*伊藤真、戸崎充男: Radioisotope Research Center, Kyoto University, Kyoto 606

**片野林太郎、五十棲泰人: Laboratory of Nuclear Radiation, Institute for Chemical Research, Kyoto University, Uji 611

***粟屋容子: The institute of Physical and Chemical Research, Wako-shi, Saitama 351

known I/r dependence. Although the proportional counter has long been studied as an energy-analyzing device, the counter performance as a device of obtaining position information has not yet been well understood, especially when the counter is operated with high-pressure counting gases. Thus, the clear situation of the electric fields of our counter helps a great deal to understand the detailed mechanism of the electron avalanche and its effect on the position resolution. It is noted that the induced charge on the cylindrically-placed cathode is several times larger than that on the flat cathode, due to the subtending solid angle.

The counter has been operated in gas-flow mode, although our goal is to develop the PSPC of sealed-gas type, which is asked in many uses because of its compactness and low-cost operation concerning counting gas, especially in case of Xe. In this paper, we report mainly the design and construction of our PSPC and its basic characteristics investigated with Ar + 30% CH₄ gas of several atmosphere and 8-keV Cu $K\alpha$ x rays.

The drawing of our PSPC is shown in Fig. 1. A duralumin box (C) of $64 \times 64 \times 240$ mm³ is used as a counter body, the center of which is holed through with 36-mm diameter. The one side of the body has an opening for a window frame (WF), to which a 1-mm thick beryllium-window plate (W) is welded. Along the center of the hole of the body, a 10- μ m diameter anode wire of gold-coated tungsten (A) is extended, being kept taut by a small spring. A backgammon pattern (BP), is rolled and put inside a cathode holder (CH₁), where the both ends of the pattern are held by other cathode holders (CH₂, CH₃). Thus, the backgammon pattern as a cathode is placed cylindrically around the anode wire. The active inner diameter is 30 mm. The backgammon pattern is

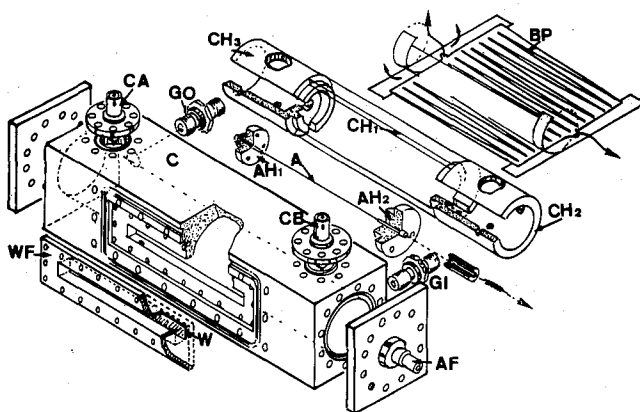

Fig.1. Drawing of the present counter: C, duralumin counter body with a volume of $64 \times 64 \times 240$ mm³; WF, stainless window frame; W, 1.0-mm thick beryllium-window plate which is welded to the window frame WF; AF, SHV connector for anode wire; CA and CB, BNC connectors for the backgammon electrodes; GI and GO, swagelok feedthroughs for gas inlet and outlet; A, 10- μ m diameter anode wire of gold-coated tungsten; AH₁ and AH₂, Teflon holders for anode wire; CH₁, stainless holder for the backgammon pattern; CH₂ and CH₃, duralumin holders for the both ends of the backgammon pattern; BP, backgammon pattern which is placed inside the holder (CH₁).

absent around the entrance-window region. Instead, the beryllium-window plate (W) is placed to provide almost complete cylindrical counter geometry, which is free from the unwanted disturbance of the electric fields. The effective window area is $4.5 \times 97 \text{ mm}^2$. In order to seal high-pressure counting gas effectively, indium wire of 1-mm diameter are mostly used as O-rings, except for feed-through connectors.

The layout of the backgammon pattern used is shown in Fig. 2. The pattern is made by photo-printing technique on about $60\text{-}\mu\text{m}$ thick film which consists of three layers: a $25\text{-}\mu\text{m}$ thick polyimide base film, about $20\text{-}\mu\text{m}$ thick epoxy-resin layer, and a $18\text{-}\mu\text{m}$ thick copper clad, respectively. Sensitive area of the pattern is $120 \times 80 \text{ mm}^2$, on which a zig-zag backgammon pattern is printed with 2.5-mm pitch. The zig-zag line divides the sensitive area into two electrodes; PA and PB in Fig. 2. The induced-charge signals taken from these electrodes are fed to charge-sensitive preamplifiers through the feedthrough connectors, CA and CB in Fig. 1.

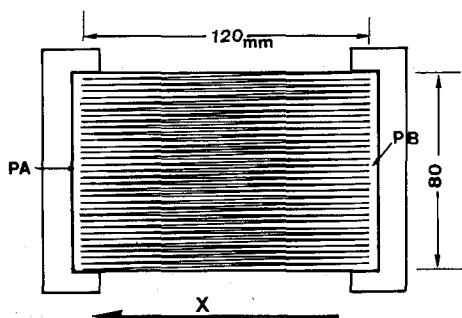

Fig.2. Layout of the backgammon pattern: PA, PB, the position-sensing parts of the pattern with an area of $120 \times 80 \text{ mm}^2$; The pitch of a zig-zag line is 2.5 mm and the spacing between the two parts is 0.2 mm. The pattern is made by photo printing on a $\sim 60\text{-}\mu\text{m}$ thick thin film consisting of a $25\text{-}\mu\text{m}$ thick polyimide base film, $\sim 20\text{-}\mu\text{m}$ thick epoxy-resin layer, and a $18\text{-}\mu\text{m}$ thick copper clad.

The active inner diameter of the counter is 30 mm so that the pattern is considered to be able to pick up 85% ($80/30\pi$) of the charge induced by an electron avalanche, providing that the distribution of the charge is uniform on cathode. However, non-uniform distribution of the induced charge occurs in the following causes: For the energies of x rays to be studied with this PSPC, the x-ray interaction with gas is dominated by photo-electric effect in that an x ray is absorbed at some interaction point and a photo electron, Auger electrons or characteristic x rays are emitted. In this primary ionization process, electron positive-ion pairs are created in the vicinity of the interaction point. These electrons are drifted towards anode wire along the lines of electric force and get enough energy, at several times away of the anode-wire thickness, to start an electron avalanche. It is well known that the electric signals obtained from a wire counter are mainly formed by the movement of the positive ions created in the avalanche. The cloud of the positive ions does not uniformly surround the anode wire, but is localized in the direction of the primary ionization, depending on the thickness of anode wire and the total charges of the positive ions. Moreover, the electric fields produced by the positive ions are shielded by the anode wire. Thus, the distribution of the induced charge on the cathode is expected to have a maximum in the direction of the primary ionization and a minimum at 180° around the anode wire.

From the view point of studying the position resolution of PSPC, it is important to know the profile of the charge distribution induced on the cathode. To our knowl-

edge, however, the study on this is very scarce³⁻⁵, either in theoretical nor experimental side. Since the charge distribution is a slowly varying function of azimuthal angle ϕ , around the anode wire, the 2.5-mm pitch of the backgammon pattern, corresponding $\Delta\phi=9.5^\circ$, is fine enough to pick correctly the induced charge up.

3. EXPERIMENTAL

The performance of the PSPC has been examined with K x rays provided from an x-ray generator. The induced-charge signals taken from the backgammon electrodes are fed to charge-sensitive preamplifiers (Canberra 2003T) and proceeded to main amplifiers (Canberra 2011) with shaping time of 1.5 μsec . The pulse heights of output signals from the main amplifiers are proportional to the amounts of induced charges sensed by the backgammon electrodes. Thus, the charge division is performed to get position information with the digital-divider electronic system used in our previous work⁹. Throughout this work, the counting gas of Ar + 30%CH₄ is used.

An x-ray generator, 15 mA and 35 kV, is used to generate Cu K -x rays. The x rays are analyzed with a flat LiF(220) crystal, $2d=2.848 \text{ \AA}$ and $75 \times 25 \times 2 \text{ mm}^3$ in size, to provide Cu $K\alpha_1$ x rays on the PSPC. Experimental setup is given in Fig. 3. The x rays travel in the air from the x-ray tube to the PSPC.

In order to examine the beam profiles when the angle of the crystal is adjusted for Cu $K\alpha_1$ line, the position spectrum is measured without using both slits of S_2 and S_3 . The spectrum is shown in Fig. 4. The PSPC is operated in the condition of anode high voltage=3.4 kV and the gas pressure of 7 atmosphere, which gives the intrinsic position resolution of $\sim 100 \mu\text{m}$ for perpendicular incidence of x rays, as explained later. As shown in Fig. 4, both $K\alpha_1$ and $K\alpha_2$ x rays are observed due to the divergence

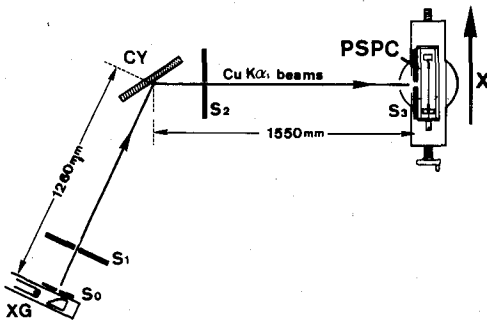

Fig.3. Illustration of the experimental setup: XG, an x-ray generator; CY, a flat LiF(220) crystal of $75 \times 25 \times 2 \text{ mm}^3$ in size; PSPC, the position sensitive proportional counter which is moved along the x direction indicated; S_0, S_1, S_2, S_3 , collimation slits.

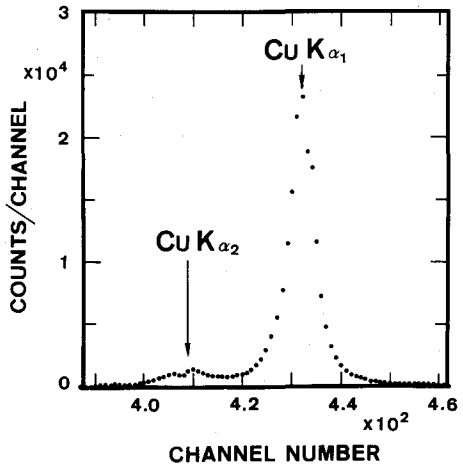

Fig.4. The position spectrum for Cu $K\alpha$ x rays. The spectrum is observed when all slits between the crystal and the PSPC are removed and the rotation angle of the crystal is adjusted for Cu $K\alpha_1$ line.

of incident beams upon the crystal. The intensity ratio of $K\alpha_2/K\alpha_1$ is largely deviated from the normal value of 0.5 because of the rotation angle of the crystal adjusted for $K\alpha_1$ line. The $K\alpha_2$ line is completely removed by using the S_2 slit of $50\text{-}\mu\text{m}$ width, which is placed 330 mm apart from the crystal. The beam width thus collimated is measured to be ~ 0.7 mm at fwhm on the PSPC. Further collimation is made by the S_3 slit placed in front of the counter. The S_3 slit used is two kinds; a $100\text{-}\mu\text{m}$ thick stainless plate with a rectangular opening of 20 mm in length and $100\ \mu\text{m}$ in width and a $50\text{-}\mu\text{m}$ thick stainless disk with a $25\text{-}\mu\text{m}$ width.

The PSPC is placed perpendicularly to the beams. The counter is moved back and forth along the x direction indicated in Fig. 3 to change the position of the x-ray incidence on the PSPC. Therefore, the incident angle is kept same as 90° wherever the incident position is, so that the position-dependent parallax effect can be minimized.

The performance of the counter has been examined by changing the high voltage (HV) applied to the anode wire and the gas pressure. The result shows that the minimum position resolution of the present PSPC is achieved at $HV = 3.2\sim 3.4$ kV and 7 atm. The examples of the spectra obtained with the collimation slit, S_3 in Fig. 3, of $100\text{-}\mu\text{m}$ width are given in Figs. 5 and 6. The spectra in Fig. 5 are observed at $HV = 2.6$ kV and 7 atm., where the gas-multiplication factor is 2.7×10^3 and the signal-to-noise (S/N) ratio is only 75 for the output signals from the main amplifiers, and the spectra in Fig. 6 are obtained at $HV = 3.2$ kV and 7 atm., where the gas-multiplication factor is 3.4×10^4 and the S/N ratio is ~ 1000 . As seen in Fig. 5(a), the energy response is the well-known one, although the intensity of the escape peak is much reduced due to higher interaction probability of Ar K x rays in the counter in comparison with that in 1 atm. The position resolution, however, is very poor. As for the energy spectrum shown in Fig. 6(a), the separation of the escape peak and the photo peak is not complete. This indicates that the operation of the counter is not in the proportional region but in the region of limited proportionality. Moreover, a bump appears at the higher-energy side of the photo peak. The study in that the gas-multiplication factor is fixed to be 3.4×10^4 has revealed that the appearance of the bump is peculiar nature

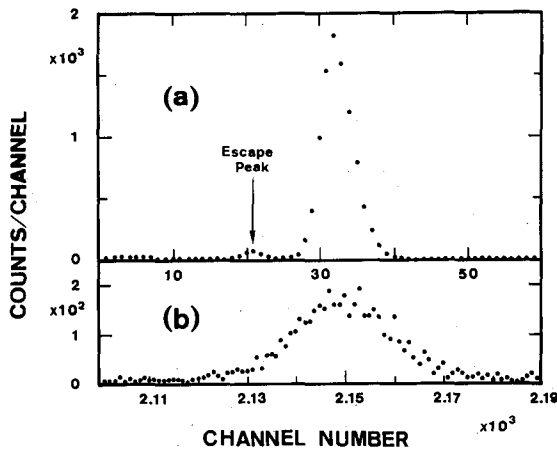

Fig.5. The energy (a) and position (b) spectra observed at the gas-multiplication factor of 2.7×10^3 . The x-ray beams are collimated with a $100\text{-}\mu\text{m}$ wide slit placed in front of the counter. The gas pressure is 7 atmosphere. The position resolution is $\sim 910\ \mu\text{m}$ at fwhm.

to the high-pressure gas; the bump shows up at about 3 atm. and the higher the pressure, the position of the bump becomes higher relative to the photo peak. The study is made up to 10 atm.

In spite of the unfamiliar energy response shown in Fig. 6(a), the position resolution is acceptable, taking account of the collimation slit of $100\ \mu\text{m}$ width. It can be said that good energy resolution is not always related to good position resolution. Since there is a possibility of obtaining better position resolution, the performance of the counter operated in the limited proportional region has been studied in detail and the results will be published elsewhere.

In order to get the intrinsic position resolution of the present PSPC, the x-ray beams are collimated with a slit of $25\text{-}\mu\text{m}$ width. The observed position spectrum is shown in Fig. 7. The spectrum is taken at $HV=3.4\ \text{kV}$ and $7\ \text{atm.}$, where the gas-multiplication factor is 5.0×10^4 and the S/N ratio is 1500. For comparison, the peak, labeled as (B) in Fig. 7, obtained with a $100\text{-}\mu\text{m}$ wide slit is also shown $5\ \text{mm}$ apart from the peak, labeled as (A), obtained with a $25\text{-}\mu\text{m}$ wide slit. The position resolution thus measured is $\sim 100\ \mu\text{m}$ at fwhm for the peak (A), whereas the resolution is $190\ \mu\text{m}$ for

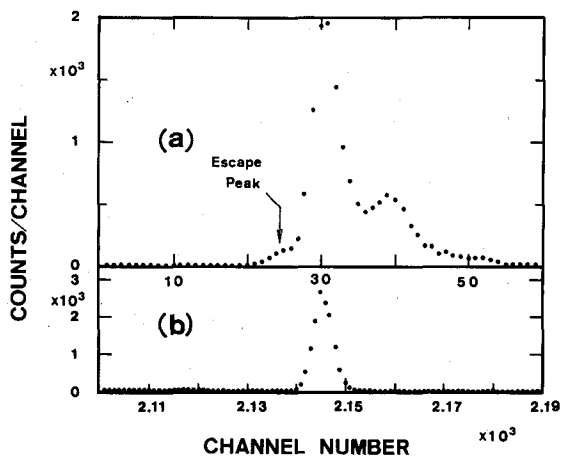

Fig.6. The energy (a) and position (b) spectra observed at the gas-multiplication factor of 3.4×10^4 . The beam collimation and the gas pressure are same as in Fig. 5. The position resolution is $\sim 190\ \mu\text{m}$ at fwhm.

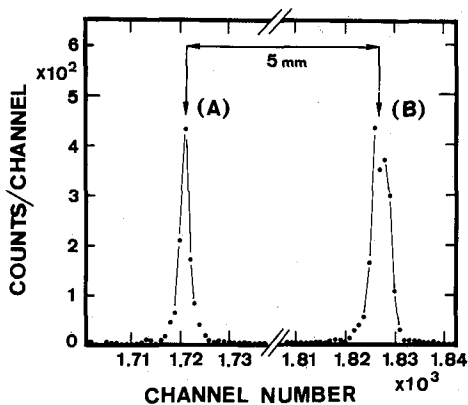

Fig.7. The position spectrum observed with well-collimated x-ray beams. The peak labeled as (A) is obtained with a $25\text{-}\mu\text{m}$ wide slit. For comparison, the peak, labeled as (B), observed with a $100\text{-}\mu\text{m}$ wide slit is also shown. The position resolution for the peak A is $\sim 100\ \mu\text{m}$ and that for the peak B is $\sim 190\ \mu\text{m}$.

the peak (B).

The design and construction of our PSPC which is developed for high energy x rays by utilizing high-pressure counting gas is presented in detail. The position readout from the cylindrically-placed backgammon pattern as a cathode has successfully been performed, giving the position resolution of $\sim 100 \mu\text{m}$ for 8-keV x rays by using 7 atm. Ar + 30% CH₄ as a counting gas. It is found in the course of this study that the events with higher gas multiplication occur and appear as a bump at the higher-energy side of the photo peak when the counter is operated at gas pressure higher than 3 atm. and in the region of limited proportionality. In order to understand this peculiar nature to high gas pressure and its relation to the position resolution, the study is in progress.

REFERENCES

- (1) J. Fischer, V. Radeka, and G. C. Smith, *Nucl. Instrum. Methods*, **A252**, 239 (1986)
- (2) R. Allemant and G. Thomas, *Nucl. Instrum. Methods*, **137**, 141 (1976)
- (3) J. Fischer, H. Okuno, and A. H. Walenta, *IEEE Trans. Nucl. Sci.*, **NS-25**, 794 (1978).
- (4) G. Charpak and F. Sauli, *Nucl. Instrum. Methods*, **162**, 405 (1979)
- (5) M. Matoba, K. Urase, H. Ohgaki, H. Ijiri, S. Uehara, T. Fujiki, N. Koori, and T. Sakae, *IEEE Trans. Nucl. Sci.*, **NS-35**, 98 (1988)
- (6) S. Kishimoto, Y. Isozumi, S. Ito, R. Katano, and H. Takekoshi, *Appl. Radiat. Isot.*, **40**, 299 (1989)