

Title	Mossbauer Measurements at Milli-Kelvin Temperature Region (Commemoration Issue Dedicated to Professor Toshio TAKADA On the Occasion of His Retirement)
Author(s)	Shinjo, Teruya; Kusuda, Toshiyuki
Citation	Bulletin of the Institute for Chemical Research, Kyoto University (1986), 64(4): 282-286
Issue Date	1986-12-06
URL	<a href="http://hdl.handle.net/2433/77151">http://hdl.handle.net/2433/77151</a>
Right	
Type	Departmental Bulletin Paper
Textversion	publisher

NOTE

## Mössbauer Measurements at Milli-Kelvin Temperature Region

Teruya SHINJO\* and Toshiyuki KUSUDA\*

Received May 15, 1986

Mössbauer measurements at extremely low temperatures have been carried out by using a  $^3\text{He}$  dilution refrigerator. Due to the nuclear polarization, the Mössbauer spectrum became asymmetric and the temperature of the  $^{57}\text{Fe}$  absorber was estimated to be 5 mk.

KEY WORDS:  $^{57}\text{Fe}$  Mössbauer spectroscopy/ Low temperature/  $^3\text{He}$  dilution refrigerator/ Nuclear polarization/

This note reports preliminary results of Mössbauer spectroscopic measurements at extremely low temperatures using a commercial  $^3\text{He}$  dilution refrigerator (Oxford, Model 100). The sample part of the cryostat, illustrated in Fig. 1, is designed

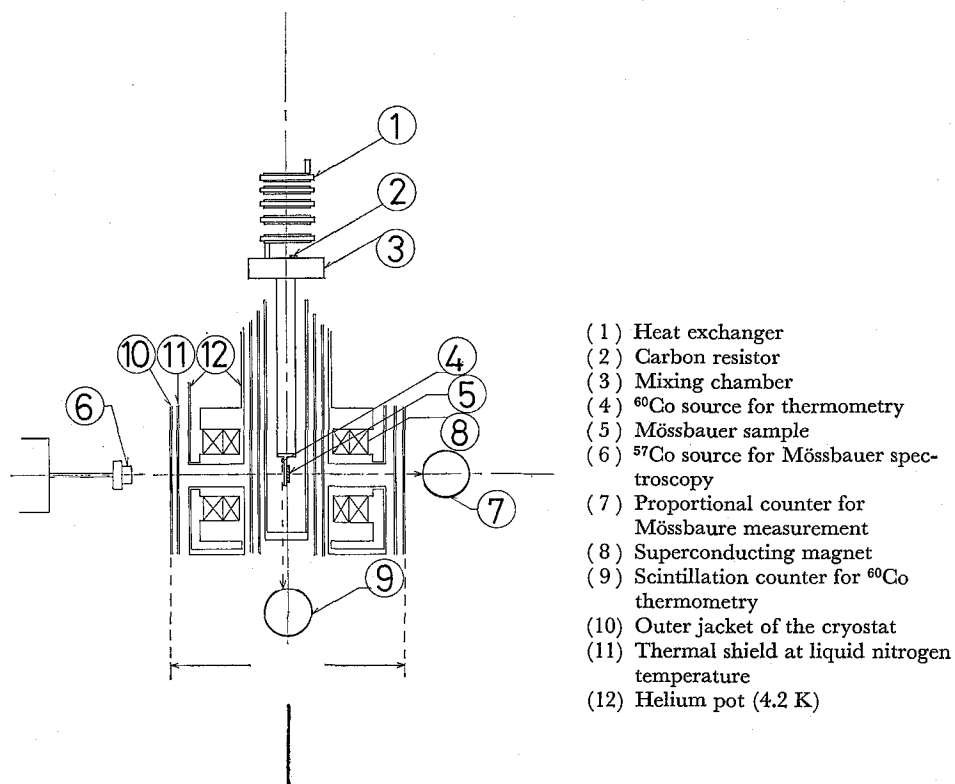

Fig. 1. The sample part of the  $^3\text{He}$  dilution cryostat.

\* 新庄輝也, 楠田敏之: Laboratory of Solid State Chemistry, Institute for Chemical Research, Kyoto University, Uji, Kyoto 611.

to cool a Mössbauer sample below 10 mK (milli-Kelvin) and also to apply an external field up to 50 kOe perpendicularly to the gamma ray direction. The Mössbauer sample is attached to the Cu block connected to the mixing chamber.

The gas mixture ( $^3\text{He}$  10L +  $^4\text{He}$  50L) is liquefied after evacuating the thermal exchange gas for more than 4 hours and circulated by a booster pump. Then the temperature begins to decrease gradually. Normally it takes about 4 hours to reach the lowest temperature. The liquid  $^4\text{He}$  is continuously supplied to the 1 K pot through a needle valve and the low temperature is kept constant until the liquid  $^4\text{He}$  in the main bath is exhausted. The temperature is monitored by carbon resistors located at several places, such as the mixing chamber, near the sample, and still.

Another thermometer is  $^{60}\text{Co}$  gamma-ray source embedded in a ferromagnetic Co film, which is soldered on the Cu block near the sample. If the temperature is low enough to polarize the nuclear magnetic moment, the gamma ray emission becomes anisotropic. From the counting rate in the direction of the bottom window, the absolute temperature is estimated. The decrease in the counting rate is expected to be 10% at 22 mK and 90% at 2 mK, respectively. Hence this thermometry is useful to calibrate temperatures below 30 mK. In Fig. 2, the calibrated

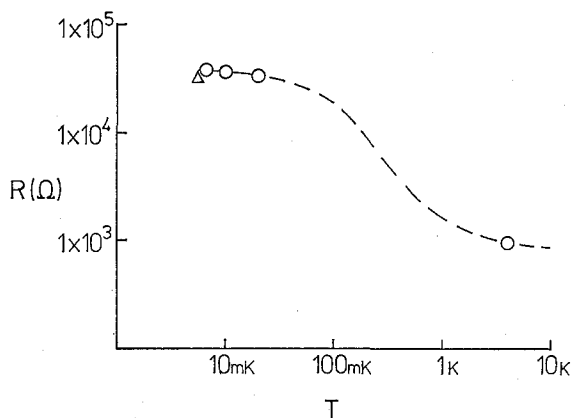

Fig. 2. Carbon resistivity vs. temperature. The circles were calibrated from  $^{60}\text{Co}$  thermometry and the triangle, from Mössbauer spectroscopy.

temperatures are plotted as a function of carbon resistance values. In order to fix the curve between 30 mK and 1 K, another method for the calibration is necessary.

The Mössbauer sample attached to the Cu block is cooled down only by the thermal conduction in solid state. If the contact of the sample to the block is not sufficient, or if the thermal conductivity of the sample itself is not good, the temperature of the sample cannot always be the same as that of the mixing chamber. The best way to estimate the absolute temperature of the Mössbauer sample is to observe the nuclear polarization in the Mössbauer spectrum. As shown in Fig. 3 (A), the Zeeman splitting of  $^{57}\text{Fe}$  ground state in ferromagnetic  $\alpha$ -Fe metal caused

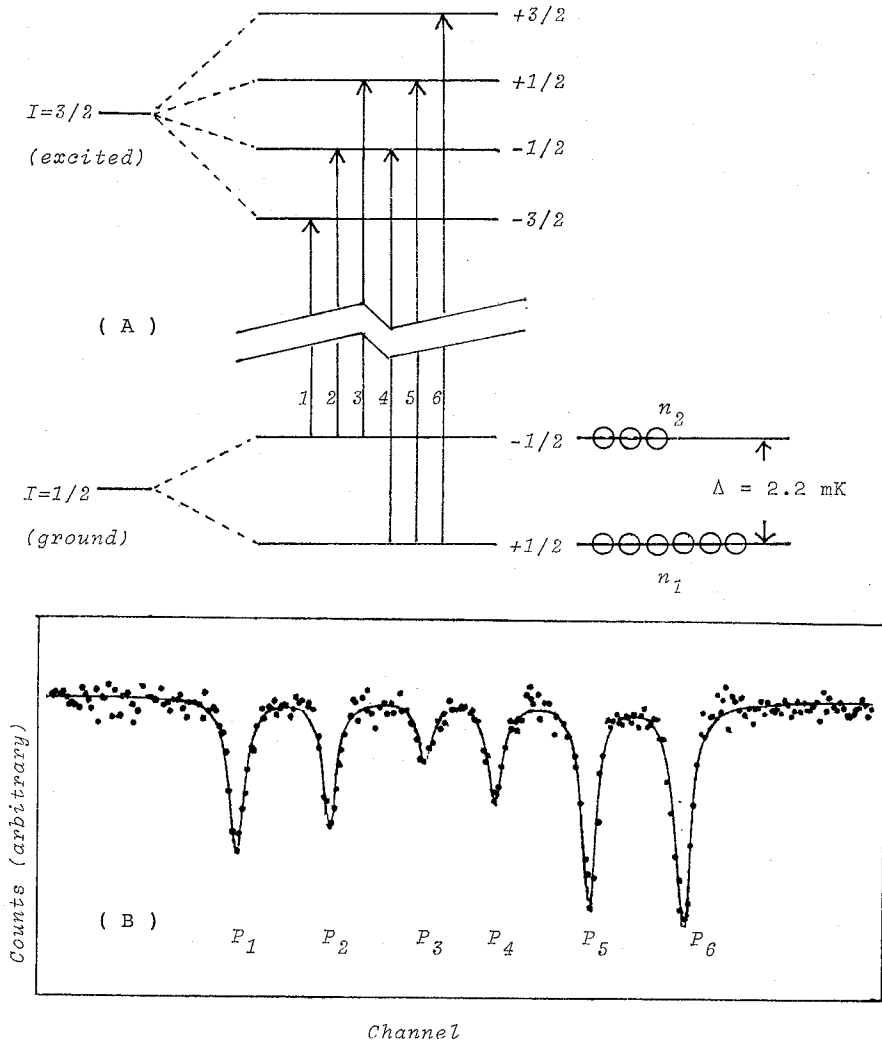

Fig. 3 (A). Nuclear energy scheme for  $^{57}\text{Fe}$  in the presence of a magnetic hyperfine field.  $\Delta$  represents the Zeeman splitting of the ground state.  $n_1$  and  $n_2$  are the populations at the levels for  $-1/2$  and  $+1/2$ , respectively.  
 (B)  $^{57}\text{Fe}$  Mössbauer absorption spectrum at an extremely low temperature (5 mK) for a natural Fe foil.

by the hyperfine field of 340 kOe corresponds to 2.2 mK. At below 10 mK, the Mossbauer spectrum should be distinctly asymmetric due to the nuclear polarization.

Figure 3 (B) is an example of the Mössbauer spectrum of a natural Fe foil at an extremely low temperature. The value of carbon resistance during this measurement (for about 10 hours) was between 34,000 and 35,000 Ohm. The observed pattern has an obvious asymmetry caused by the nuclear polarization. If we number the six transitions, 1, 2, ..., 6, from the lower to the higher energy, the intensity ratios,  $P_1/P_6$ ,  $P_2/P_5$  and  $P_3/P_4$  are all the same as the ratio of populations,  $n_2/n_1$ . Here

the thickness effect may be neglected since the absorber is regarded as ideally thin ( $5 \mu\text{m}$ ). The spectrum is fitted by assuming six independent Lorentzians and the ratio of  $P_1/P_6$  and  $P_2/P_5$  are estimated to be 0.66 and 0.63, respectively. The ratio of the populations,  $n_2/n_1$ , is derived to be  $0.65 \pm 0.02$  as the average of these values. The intensities of  $P_3$  and  $P_4$  are weak and are not included in the calculation. The sample temperature,  $T$ , calculated from the formula,  $\exp(-2.2/kT) = 0.65$ , is 5.1 mK. Although this value is somewhat lower than the calibrated value from  $^{60}\text{Co}$  measurement in the previous run, it seems reliable within an accuracy of 0.5 mK.

The above result indicates that a Mössbauer absorber sample can be cooled down to the same temperature as the mixing chamber at least in the case of metallic samples. If the spectrum shows a resolved six line pattern, the sample temperature is easily estimated from the asymmetry. This is the most reliable and straightforward method of determining the absolute temperature of the Mössbauer sample.

Figure 4 is the Mössbauer spectra for an alloy film of Fe(0.5%)-Mg (99.5%).

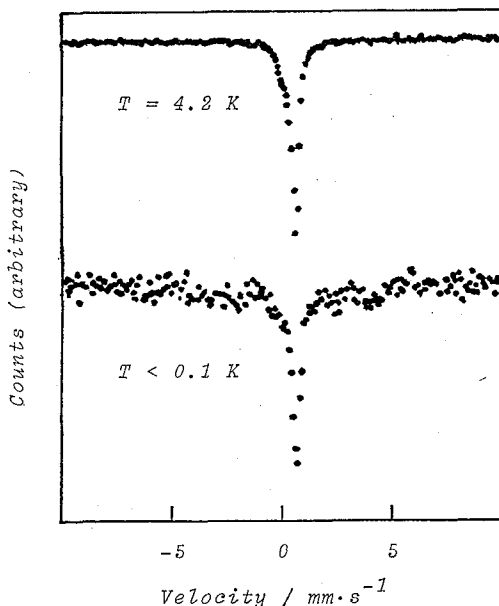

Fig. 4.  $^{57}\text{Fe}$  Mössbauer absorption spectra at 4.2 K and at lower than 0.1 K of Fe(0.5%)-Mg(99.5%) film prepared by co-deposition technique.

In order to study Fe impurity in Mg matrix, the alloy film was prepared by a co-deposition technique. At 4.2 K, the spectrum has no magnetic hyperfine structure. The main singlet peak is rather sharp but obviously there is a shoulder part with small isomer shifts. At lower than 1 K, the non-magnetic line is still observed. This result suggests the following: The sharp singlet corresponds to isolated Fe impurities in Mg matrix, which carry no local magnetic moment. The shoulder part is due to Fe-rich clusters which have magnetic moments and fall into magnetically ordered states at the lower temperature. The sample temperature seems to

be much lower than 0.1 K but was not clearly identified. Since the substrate of the sample is a mylar film, whose conductivity is not good, the homogeneity of the sample temperature is uncertain.

In collaboration with Professor M. Takano, a study on  $[\text{Fe}_3\text{O}(\text{CH}_3\text{COO})_6(\text{H}_2\text{O})_3]\text{Cl}\cdot 6\text{H}_2\text{O}$  is in progress. In this compound, triangular  $\text{Fe}^{3+}$  clusters have spin 1/2 in the ground state owing to strong antiferromagnetic intracluster interactions. The intercluster coupling being weak, the magnetic ordering does not appear at the ordinary temperature region. Actually the Mössbauer spectrum at 1 K does not show any magnetic hyperfine structure. As is shown in Fig. 5,

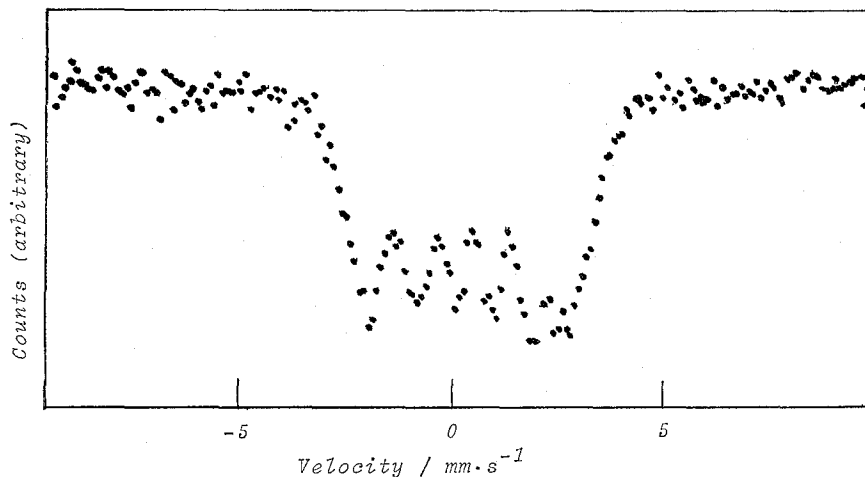

Fig. 5.  $^{57}\text{Fe}$  Mössbauer absorption spectrum at a very low temperature for a triangular  $\text{Fe}^{3+}$  cluster compound,  $[\text{Fe}_3\text{O}(\text{CH}_3\text{COO})_6(\text{H}_2\text{O})_3]\text{Cl}\cdot 6\text{H}_2\text{O}$ .

a magnetically split spectrum is observed at a very low temperature and the existence of a magnetic ordering is confirmed for the first time. The carbon resistor at the magnetic transition temperature is about 9,000 Ohm. The details will be published elsewhere.

The authors would like to thank Dr. N. Hosoito for the analysis of Mössbauer spectra, Dr. K. Kawaguchi for preparing the Fe-Mg sample, and Professor Emeritus T. Takada for continued encouragement. The dilution refrigerator was purchased by a Grant-in-Aid from the Ministry of Education, Culture and Science.