

Title	Formation of Oxide Fibers by Unidirectional Freezing of Gel (Commemoration Issue Dedicated to Professor Toshio TAKADA On the Occasion of His Retirement)
Author(s)	Maki, Toshio; Kokubo, Tadashi; Sakka, Sumio
Citation	Bulletin of the Institute for Chemical Research, Kyoto University (1986), 64(4): 292-305
Issue Date	1986-12-06
URL	http://hdl.handle.net/2433/77149
Right	
Type	Departmental Bulletin Paper
Textversion	publisher

Formation of Oxide Fibers by Unidirectional Freezing of Gel

Toshio MAKI*, Tadashi KOKUBO* and Sumio SAKKA*

Received May 30, 1986

Alumina, titania and zirconia fibers have been prepared by unidirectional freezing of gel. This method, which consists of (1) gel formation by dialysis of sol, (2) unidirectional freezing of gel and (3) thawing of the frozen gel, gives porous oxide hydrate fibers of several tens micrometers in diameter with an angular cross-section in as-prepared state. Conditions for the fiber formation have been discussed in terms of the concentration of sol, the time of dialysis for gelation, the shape of sol particles and the rate of freezing. Microstructures, properties and their change with heating have been also described.

KEY WORDS: Sol-gel/ Unidirectional freezing/ Alumina/ Titania/
Zirconia/ Fibers/

1. INTRODUCTION

Fibers of ceramic oxides, such as Al_2O_3 , TiO_2 and ZrO_2 , have a wide variety of applications for their refractoriness, chemical stability and catalytic activity. Refractories, fibers for reinforcing glasses and metals, and catalysts and catalyst carriers are some of the examples. Solid, high strength fibers may be suitable as high temperature structural materials, while oxide fibers with fine pores may be important for catalytic applications.

Since it is difficult to draw alumina, titania and zirconia fibers from the high temperature melt due to the low viscosity of the melt, they are produced through the low temperature processes. In such processes, fibers are drawn at near room temperature from highly concentrated, viscous solutions of metal salts⁽¹⁾, or from metal alkoxide sols which are viscous and spinnable as a result of hydrolysis and polycondensation.⁽²⁾ Heating of drawn fibers give us oxide fibers.

The present method of unidirectional freezing of gel is a variant of the low temperature preparation of oxide fibers. The fibers obtained are porous in as-prepared state. Another characteristics is that the fibers have an angular cross-section. Heating of the fibers changes the porous nature to non-porous nature. Mahler and Bechtold⁽³⁾ made silica fibers by unidirectionally freezing the gel prepared by dealkalizing alkali silicate sol through ion-exchange. In this paper, the preparation of alumina^(4,5), titania⁽⁶⁾ and zirconia⁽⁷⁾ fibers by unidirectional freezing of gel has been reviewed on the basis of our works. Alumina ceramics (Al_2O_3) with melting point (m.p.) of 2045°C is one of the most popular industrial ceramics and is widely used for its high thermal conductivity. Titania (TiO_2) with m.p. of 1845°C is famous for the photocatalytic effect. Zirconia (ZrO_2) with m.p. of

* 牧 俊夫, 小久保正, 作花濟夫: Laboratory of Ceramic Chemistry, Institute for Chemical Research, Kyoto University, Uji, Kyoto-Fu 611.

2700°C will be used as high strength, high fracture toughness ceramics by stabilizing.

2. OUTLINE OF THE METHOD

Fig. 1 shows typical examples of the gel fibers (titania) prepared by the present method. (a) is a photograph of an as-prepared bundle of fibers, (b) is a scanning electron microscopic (SEM) photograph of separated fibers and (c) is a SEM photograph of the cross-sections of the fiber. It is seen that the fibers are continuous

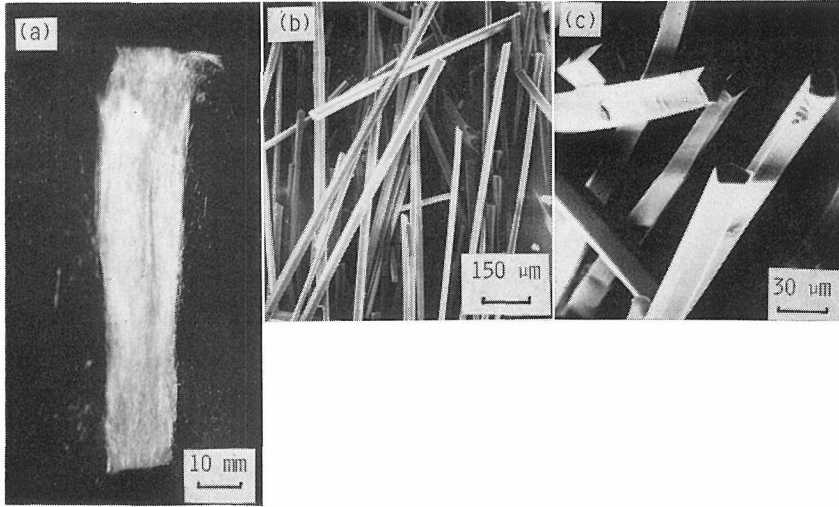

Fig. 1. Fibers prepared by unidirectional freezing of titania gel. The gel was prepared from the 2.0 M TiO_2 hydrosol.

(a) Photograph of a bundle of fibers. (b) and (c) SEM micrographs of fibers.

with more than several centimeters in length and have an angular cross-section.

The process of fiber formation based on the unidirectional freezing of gel consists of (1) preparation of hydrosol, (2) gelation of the sol, (3) unidirectional freezing of the gel and (4) thawing of the frozen mass.

The sols are prepared by various methods including hydrolysis of metal chloride or oxychloride. The sol is solidified into gel by removing anions contained in it. The sol, placed in a cellulose tube with 25 Å pores, has been dialyzed in distilled water for alumina, titania and zirconia. The pH of the sols increases to 3–6 as a result of the dialysis. In the process of dialysis of an alumina sol, the pH of the sol increases and the weight of the tube changes, as shown in Fig. 2, indicating that acetate anions in the sol go out of the tube and water enters into the tube. The sols are solidified into gels when the pH becomes closer to the values corresponding to the isoelectric point of the oxide.⁽⁸⁾

The cylindrical gel mass thus obtained is placed in a polyethylene cylinder of 15–20 cm in length and 8–30 mm in diameter, and unidirectionally frozen by immersing the cylinder into a cold bath of -78°C at a rate between $1\text{--}13\text{ cm h}^{-1}$. Fig. 3 shows an apparatus used for this unidirectional freezing. The combination

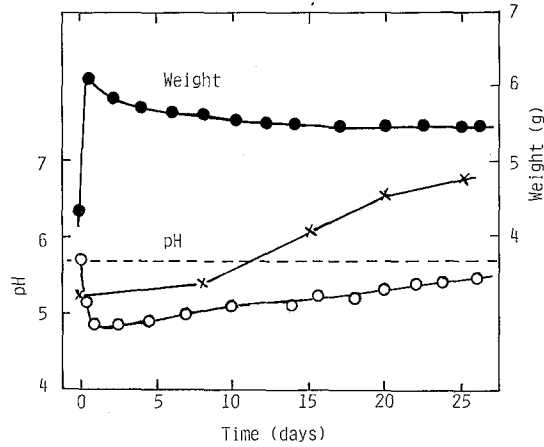

Fig. 2. Variations in pH and weight of Al_2O_3 sol C2 and pH of buffer solution during dialysis process. The water for dialysis was renewed every about one day. The dotted line shows the pH value of distilled water used for dialysis.

● — weight of sol, —×— pH of sol,
 ○ — pH of buffer solution

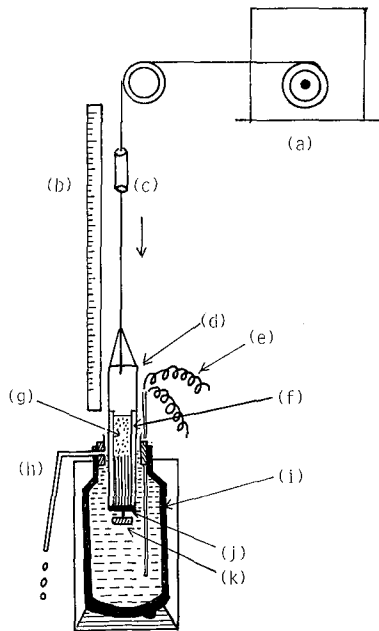

Fig. 3. Apparatus used for unidirectional freezing of gel. (a) Motor, (b) Scale, (c) Guide, (d) Polyethylene cylinder, (e) CA thermocouple, (f) Polyurethane foam, (g) Gel, (h) Overflow, (i) Dry ice/Ethanol cold bath, (j) Brass bottom, (k) Weight

of dry ice and ethanol serves as cold medium.

After freezing of the whole cylinder, the frozen gel is taken out of the polyethylene cylinder and is kept at room temperature on a petri dish, in order to thaw and dry the frozen mass. A bundle of oxide fibers is left on the dish. The bundle is separated into individual fibers, as shown in Fig. 1, when the conditions of the precedent processes are appropriate. When the conditions are not satisfactory, the products left after thawing are granules or very short fibers less than several millimeters in length. In some case, the bundle may remain an aggregation after the thawing process because of water bonding the constituent fibers or granules tightly, and individual fibers or granules cannot be separated from each other.

3. REQUIREMENTS FOR FIBER FORMATION

The angular cross-section of the resultant fibers shown in Fig. 1 suggests that in the unidirectional freezing process, ice columnar crystals are formed in the gel by the cellular growth and the oxide fine particles in the gel are concentrated into long, narrow spaces surrounded by the ice crystals. It is also assumed that the oxide or oxide hydrate particles within each fiber are chemically bonded, but no chemical bond is formed between fibers and so the desired fibers are prepared after the thawing.

In other words, the continuous oxide fibers in which the oxide particles are chemically bonded and which have no tight bonding with each other must be formed, in order for the present method to be successful. This leads to the following conditions for each of the processes involved in the method.

3.1 Starting sol.

The sol has to contain oxide particles larger than a certain size which do not go out of the cellulose tube in dialysis. The concentration of oxide component must be sufficiently high to fill the spaces between fibrous ice crystals, so that the oxide fibers in the frozen gel might be continuous. The oxide particles of the sol must be mobile so that they may be rearranged into the spaces between ice fibrous crystals upon unidirectional freezing of gel. In addition, chemical bonds have to be formed within each fiber, but tight bonds should not be formed between fibers. As to this condition, the shape and chemical nature of the oxide particles may be important.

3.2 Dialysis of the sol.

Dialysis must be carried out for a long time sufficient for removal of the electrolytes, such as chloride, acetate or alkali ions. If a small amount of electrolytes still remains after dialysis, oxide particles might not make chemical bonds in each other in the freezing processes. However, for some oxide, the dialysis time is limited by possible cracks in the gel cylinder, since the continuity of fibers may be interrupted by such cracks.

3.3 Unidirectional freezing.

The rate of immersion of gel cylinder into the cold bath should be in an appropriate range, so that cellular growth of ice fibrous crystals might take place.

The above requirements described in 3.1, 3.2 and 3.3 should be common to all the oxides. Formation of alumina fibers will be used as an example for checking these requirements.

Characteristics of five types of alumina sols A–E used are shown in Table 1. Electron micrographs of particles in the sols are shown in Fig. 4. For gelation, the sol was put into a cellulose tube with 2.4 nm micropores, 120 mm in length and 8 mm in diameter and dialysed with 2 liter distilled water at 25°C for up to 30 days. The cylindrical gel mass, 100 mm long, placed in a polyethylene cylinder

Table 1. Characterization of alumina sols used

Sol	Appearance	Al ₂ O ₃ content (mol/l)	Viscosity at 25°C (Pa·S)	Initial pH	Stabilizing agent	Gelation time (days)	Shape of sol particles
A 1	Opaque	1.0	0.01–	4.0	NO ₃ ⁻	No gelation	} Round
A 2	Opaque	2.0	0.018	3.8	NO ₃ ⁻	25–30	
B 1	Opaque	1.0	1.08	3.7	Cl ⁻	30	} Feather like
B 2	Opaque	1.5	10	3.5	Cl ⁻	25–30	
C 1	Opaque	0.5	0.005	5.5	CH ₃ COO ⁻	25–30	} Feather like
C 2	Opaque	1.0	0.12	5.3	CH ₃ COO ⁻	18–25	
C 3	Opaque	1.5	9–10	5.0	CH ₃ COO ⁻	25	
D	Translucent	1.0	0.1	3.8	CH ₃ COO ⁻	5–15	} Fibrils
E	Translucent	1.0	7.5	4.1	CH ₃ COO ⁻	5–15	

A, B and C: From commercial sources D and E: Prepared for this study

Sol D was prepared by dissolving Al powder into 2.5% diluted acetic acid and subsequently heating the resultant suspension at 93°C. Sol E was prepared by hydrolysing Al-tris-isobutoxide in water of 75°C and heating the resultant suspension in reflux at 95°C after addition of acetic acid.

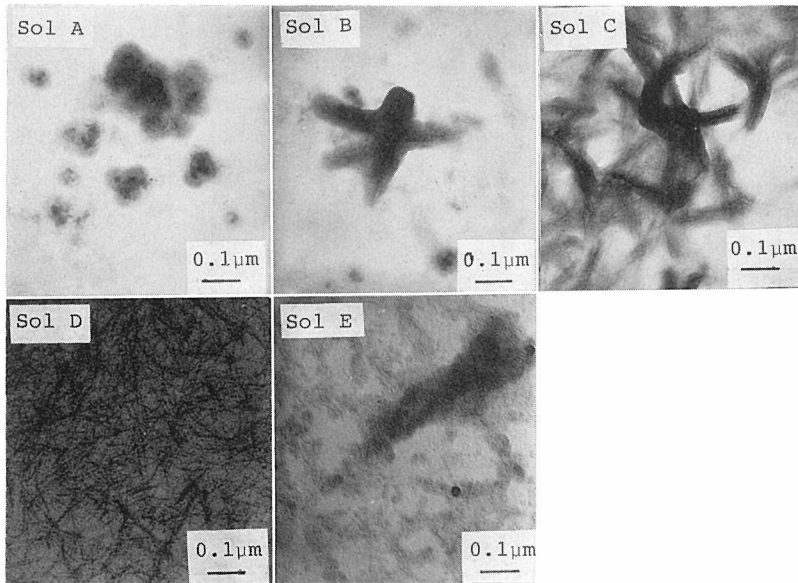

Fig. 4. Transmission electron micrographs of particles found in sols.

was unidirectionally frozen by immersing the cylinder downward into a cold bath of -78°C at a rate of 3, 6, 9, or 13 cm h^{-1} . Not all gels gave fibers after thawing of the frozen gel, as shown in Table 2.

As to starting sol, Table 2 shows that higher concentrations of oxide component

Table 2. Formation of alumina fibers by unidirectional freezing

Sol	Gelation	Cellular growth	Fiber
A 1	No gelation	No	No
A 2	Soft gel	Not distinct	No
B 1	Soft gel	No	No
B 2	Soft gel	Distinct	Yes
C 1	Soft gel	Distinct	Yes (partly)
C 2	Firm gel	Distinct	Yes
C 3	Firm gel	Distinct	Yes
D	Firm gel	Not distinct	No
E	Firm gel	Not distinct	No

in the starting solution (1.5 M in B2) give fibers, while a lower concentration (1.0 M in B1) does not give fibers. Table 2 also shows that only sols B and C containing feather-like particles, which consist of fine, fibrous, amorphous particles (Fig. 4) form fibers. It is easily understood that such particles stick together during concentration of those into fibers on cellular growth of ice fibrous crystals. Sol A consists of round, crystalline particles (Fig. 4 and Table 1), which would give only weak bonding between particles, resulting in the collapse of fibers into original particles on thawing of the frozen matter. For the formation of fibrous ice crystals during

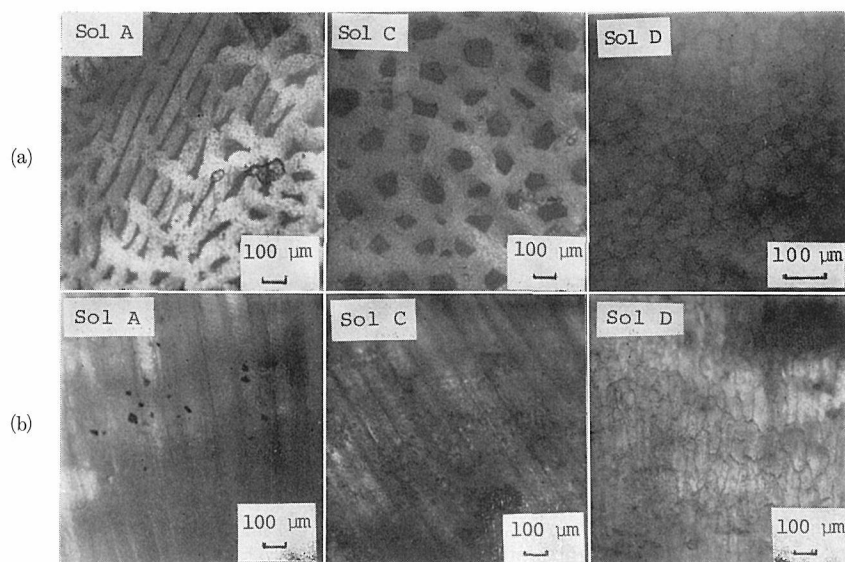

Fig. 5. Low temperature optical micrographs of lateral (a) and longitudinal (b) cross-sections of unidirectionally frozen gels.

unidirectional freezing, which is a necessary condition for obtaining alumina fibers, the water has to be separated from the alumina component. It is likely that the water is not easily separated in gels derived from sols D and E during unidirectional freezing of gel, being kept as hydration water. Fig. 5 shows the cross-sections of the frozen masses. A clearcut separation of ice crystals from alumina component is seen in sol C, while the separation of ice from alumina component is not clear in sols D and E. This may explain why alumina fibers cannot be obtained from these gels. It has been observed that no water is separated from the frozen gel on thawing.

As to the time of dialysis, the alumina sol had to be dialyzed for 18–30 days to convert it to the firm gel suitable to unidirectional freezing. In the final stage of the dialysis, the weight of gel became nearly constant values (Fig. 2).

In the unidirectional freezing of gel, the immersion rate of the gel cylinder markedly affects the formation of fibers. Table 3 shows the effect of the immer-

Table 3. Characteristics of freeze-formed alumina products for sol C2

Immersing rate of cylinder (cm·h ⁻¹)	Form of the product	Length of fibers (mm)	Diameter of fibers (μm)
3	Granules	—	—
6	Fibers	5–10	100–200
9	Fibers	5–10	70–100
9 (Aged)	Fibers	30–50	60–100
13	Granules	—	—

sion rate on the fiber formation for the gel derived from sol C2. It is seen that fibers are formed at appropriate, intermediate immersing rates (6 cm h⁻¹ and 9 cm h⁻¹) which cause the cellular growth of ice fiber crystals as evidenced from the photograph of the cross-sections shown in Fig. 5. Only granules and very short fibers were formed for immersing rates lower than 3 and higher than 10 cm h⁻¹.

It is assumed that the shapes of oxide gels in the frozen mass may be defined by the shape of frozen ice crystals. Accordingly, the formation of fibers may be discussed in terms of the freezing rate R and temperature gradient at the freezing front G, which may depend on the immersing rate of the cylinder. Flemings⁽⁹⁾ expresses the condition for the plane front growth of the solvent in the unidirectional solidification of the solution as follows.

$$G/R \geq mC_0(1-k)/KD \dots\dots\dots(1)$$

Here, m is the slope of liquidus, C₀ is the initial concentration of the solution, K is the partition ratio and D is the slope of liquidus line, C₀ is the initial concentration of the solution, K is the partition ratio and D is the diffusion coefficient. The similar reasoning of solidification is assumed to hold in the unidirectional freezing of ice, which is considered in this experiment. In freezing of the same gels, the value of the right-hand side of formula (1) is identical. When G/R is large, owing to

the small immersing rate, the ice crystals grow by the plane front growth mechanism, as illustrated in Fig. 6 (a). Then, alumina component is expelled to the front area of the freezing ice crystals and no alumina fibers may be formed. This explains why no long fibers are formed for immersing rates smaller than 2 cm h^{-1} .

For high immersion rates causing smaller G/R values, ice crystals grow by the cellular growth mechanism as ice fibers. The Al_2O_3 component is concentrated in the region between ice fibers, forming alumina gel fibers on freezing (Fig. 6 (b)). The formation of long fibers for larger immersion rates is explained by this reasoning.

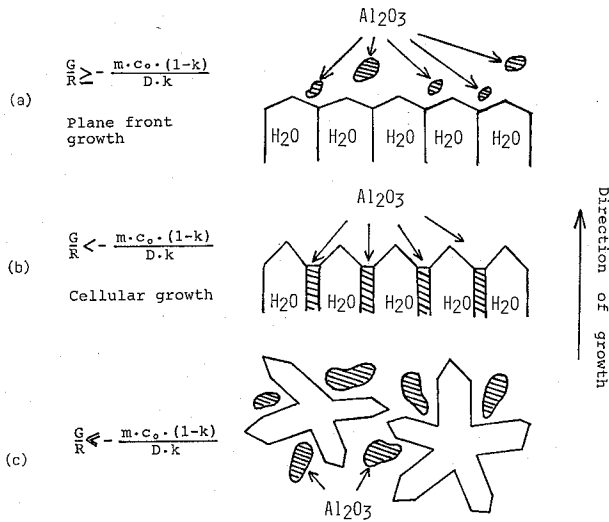

Fig. 6. Schematic diagrams showing the growth of ice during unidirectional freezing of gel.

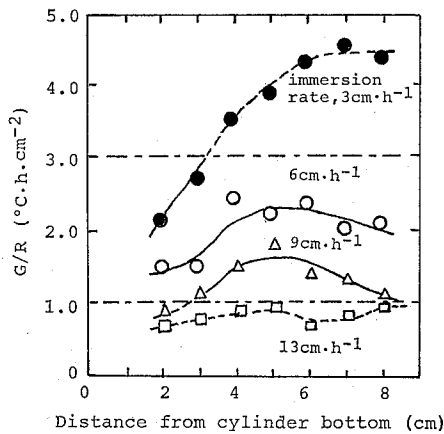

Fig. 7. Ratio of temperature gradient (G) to freezing rate (R) versus distance from cylinder bottom during unidirectional freezing of gel derived from Al_2O_3 sol C2.

Oxide Fibers by Unidirectional Freezing

For too high immersion rates causing very low G/R values, however, the occurrence of large constitutional supercooling causes formation of discrete, particulate ice crystals and no long fibers are formed (Fig. 6 (c)). This explains why no long fibers are formed for immersion rates higher than 10 cm h^{-1} . Fig. 7 shows G/R as a function of the distance from the bottom of the cylinder for various immersion rates. In the figure, two dashed lines indicate the G/R range where continuous fibers can be obtained. It is indicated that long fibers can be obtained for G/R range between 1 and $3^\circ\text{C h cm}^{-2}$.

It should be remarked that similar experimental results have been obtained on the effect of factors governing successful formation of titania⁽⁶⁾ and zirconia⁽⁷⁾ fibers. Starting chemicals and some other important remarks on the formation of alumina, titania and zirconia fibers are given in Table 4. The data on silica fibers obtained by Mahler and Bechtold⁽³⁾ are added.

4. PROPERTIES AND STRUCTURE OF FIBERS

Properties and structure of the alumina, titania and zirconia fibers obtained by the present method are summarized in Table 4. Those of silica fibers shown by Mahler and Bechtold⁽³⁾ are also shown for reference. Changes by heating are also shown.

Table 4. Fibers obtained by the unidirectional freezing of gel

	Alumina	Titania	Zirconia	Silica
Starting chemical	Sol	TiCl ₄	ZrOCl ₂ ·8H ₂ O	Na ₂ O·nSiO ₂ (n≅3) (water glass)
Preparation of sol	—	Hydrolysis	Hydrolysis	Ion exchange
Oxide concentration (Mol l ⁻¹)	1.5	1-2	≥1	1
Gelation	Dialysis with H ₂ O	Dialysis with H ₂ O	Dialysis with H ₂ O	pH adjustment
Rate of immersion into cold medium (cm h ⁻¹)	5-10	2-5	3-6	2-4
Length of fiber (cm)	1-5	≈10	≈10	11
Diameter of fiber (μm)	60-100	30-80	10-60	50
Composition of fiber	Al ₂ O ₃ ·2.3H ₂ O (110°C)	TiO ₂ ·0.3H ₂ O (120°C)	ZrO ₂ ·H ₂ O (290°C)	SiO ₂ ·0.3H ₂ O (150°C)
Specific surface area (m ² g ⁻¹)	240 (110°C)	350 (120°C)	—	900 (150°C)
Tensile strength (MPa)	180 (1000°C)	20 (120°C)	30 (290°C)	510 (925°C)

4.1 Diameter of fibers.

The change of the diameter of the fibers with the position in the gel cylinder is discussed with the data on zirconia fibers. The diameter of fibers thus obtained increases with increasing distance from the bottom. For instance, the diameter was 30 μm at the bottom and 50 μm at the top of the cylinder for the immersion

rate of 4 cm h^{-1} . According to Flemings⁹⁾, the intercellular distance, that is, the fiber diameter linearly increases with increasing $(RG)^{-1}$ in the cellular growth of unidirectional solidification. The above fiber diameter means the diameter of ice crystals. In the present case, it is assumed that the diameter of zirconia fibers may be proportional to the diameter of ice crystals, because the diameter of long spaces between ice fibers increases with that of ice fibers at the same ice content. Accordingly, the diameter of oxide gel fibers linearly increases with the $(RG)^{-1}$. Figure 8 shows that the diameter of zirconia gel fibers follows the above relation.

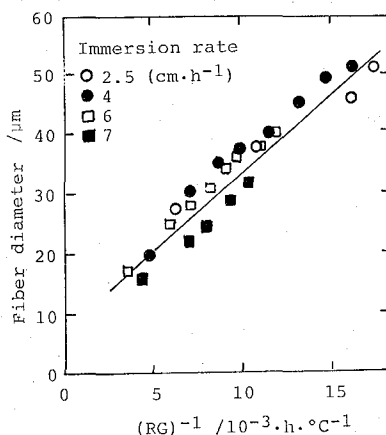

Fig. 8. Relation between the fiber diameter and the reciprocal of the product of the freezing rate (R) and the vertical temperature gradient (G) at the freezing front. The fibers were prepared from the gel derived from 1 M ZrO_2 sol.

The similar linear relation between the diameter of the oxide fiber and $(RG)^{-1}$ has been also obtained for alumina⁴⁾ and titania⁶⁾ fibers.

4.2 Composition and porosity of fibers.

The oxides which constitute fibers prepared in this method are hydrated in the as-prepared state, since the polycondensation occurs in the water environment during processing of sol preparation, gelation and unidirectional freezing. The fibers are also porous, because free water is incorporated in the voids of fiber structure, and goes out of the fiber on drying.

After heating at low temperatures the free water would be released from the fiber. As shown in Table 4, alumina fibers had a composition $\text{Al}_2\text{O}_3 \cdot 2.8\text{H}_2\text{O}$ after vacuum drying at 110°C , titania fiber a composition of $\text{TiO}_2 \cdot 0.3\text{H}_2\text{O}$ after drying at 120°C and zirconia fibers a composition of $\text{ZrO}_2 \cdot \text{H}_2\text{O}$ after heating at 290°C . The high water content of as-prepared alumina fiber might be attributed to the water-absorbing nature of boehmite crystals constituting alumina fibers⁽¹⁰⁾.

As to the micropores found in the fibers, the specific surface area was $240 \text{ m}^2 \text{ g}^{-1}$

for alumina fibers, after heating at 110°C and 350 m²g⁻¹ for titania fibers after heating at 120°C. Zirconia fibers show only a small specific surface area, probably because the pores were filled with water after heating at 290°C.

The water content and pore structure of the fibers changed with heating at higher temperature. As shown by the thermogravimetric analysis (TG) curve in Fig. 9, alumina fibers of the composition Al₂O₃·2.8H₂O starts to lose the hydration water at 120°C and most of the water is gone at about 500°C. Hydrated titania and zirconia fibers also lose the hydration water at higher temperatures.

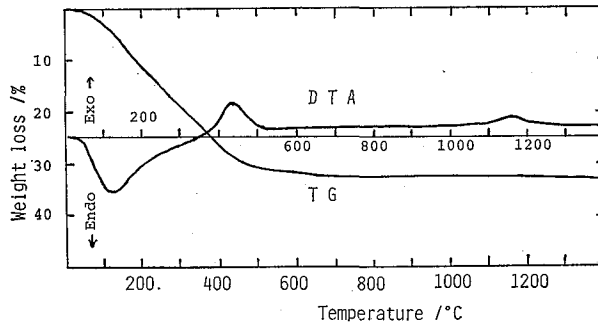

Fig. 9. DTA and TGA curves of freeze-formed alumina fibers preheated at 110°C in vacuum for 2 h.

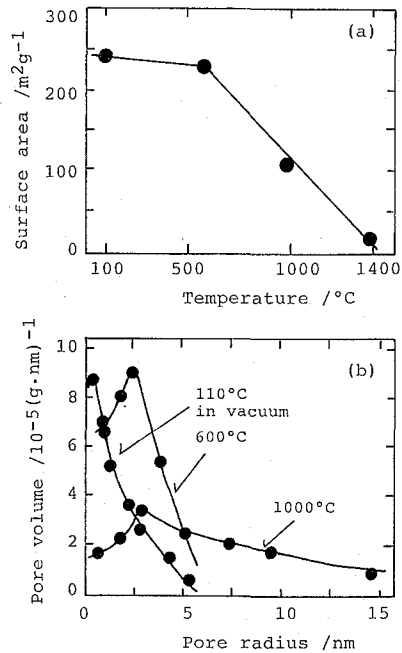

Fig. 10. N₂ BET surface area of freeze-formed alumina fibers as a function of heating temperature (a) and pore distribution of fibers dried at 110°C in vacuum for 2 h and fibers heated at higher temperature (b).

The change of specific surface area and state of micropores of alumina fibers are shown in Fig. 10. It is seen that the specific surface area decreases and average pore volume also decreases with rising heating temperature.

4.3 Structural state of fibers.

It has been found that in the case of alumina, fibers can be formed⁵⁾ only from sols B and C which contain almost amorphous alumina hydrate particles. Other sols which contained boehmite crystals could not be formed into fibers. As shown by X-ray diffraction patterns in Fig. 11, diffuse peaks of boehmite crystal are found

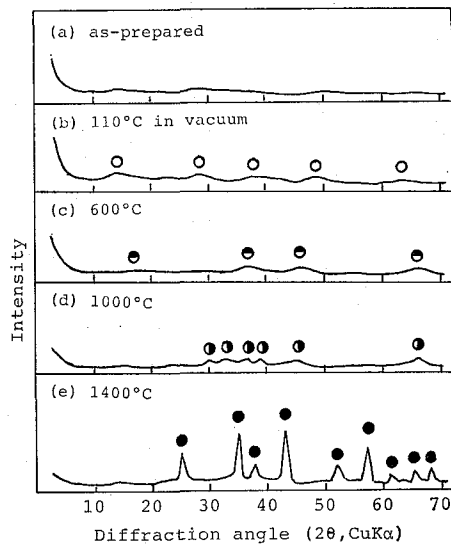

Fig. 11. X-ray diffraction patterns of alumina fibers as-prepared, dried at 110°C in vacuum and heated at higher temperatures. The marks indicate the peaks of alumina crystals.

○ γ -AlOOH (boehmite), ◐ η -Al₂O₃,
◑ θ -Al₂O₃, ● α -Al₂O₃

in the as-prepared fiber, and the diffraction peaks become more distinct when the fibers are heated at 110°C in vacuum. This indicates that the as-prepared fibers are essentially amorphous with fine grained boehmite crystals. Heating at higher temperatures changes the crystalline phase from boehmite to η -Al₂O₃ (near 600°C), θ -Al₂O₃ (near 1000°C), and α -Al₂O₃ (near 1200°C). α -Al₂O₃ is the stable phase of alumina.

Titania fibers contain fine-grained anatase crystals in the samples dried at room temperature or at 120°C. The anatase phase changes to rutile when fibers are heated at higher temperatures than 670°C.

Zirconia fibers are amorphous in the as-prepared state. The amorphous nature is kept even after heating at 290°C. The infrared spectral study shown in Fig. 12 suggests that this amorphous hydrated zirconia contains Zr atoms in eight-coordinated state.⁷⁾ This result is shown in Fig. 12. Heating of the fibers at 400–500°C produces crystals consisting of a mixture of cubic and monoclinic zirconia.

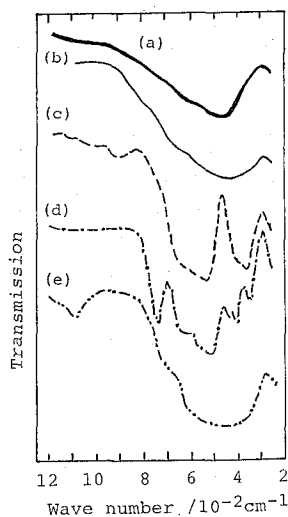

Fig. 12. IR spectra of freeze-formed zirconia fibers as-dried at 25°C (a) and heated at 290°C (b), CaZrO_3 (c), monoclinic ZrO_2 (d) and $(\text{ZrO}_2)_{0.8}(\text{Y}_2\text{O}_3)_{0.2}$ (e) crystals.

Heating at higher temperature makes monoclinic phase dominant.

4.4 Mechanical strength.

As-prepared fibers are in the state of gel and are not mechanically strong. The tensile strength of alumina fibers changes with heating temperature, as shown in

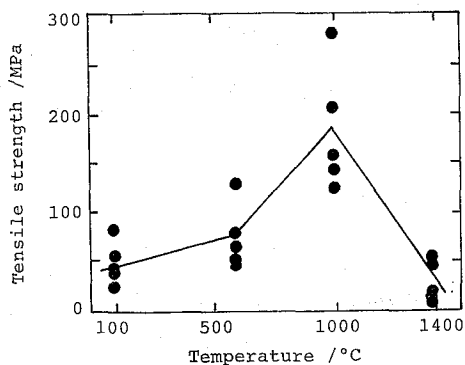

Fig. 13. Tensile strength of freeze-formed alumina fibers as a function of heating temperature.

Fig. 13. It is seen that the strength becomes maximum at 180 MPa in average. The strength decreases again at higher heating temperature. This might be attributed to precipitation of large $\alpha\text{-Al}_2\text{O}_3$ crystals.

Oxide Fibers by Unidirectional Freezing

REFERENCES

- (1) E. Leroy, C. Robin-Brosse and J.P. Torre in "Ultrastructure Processing of Ceramics, Glasses, and Composites", L.L. Hench and D.R. Ulrich Ed., John Wiley and Sons, New York, 1984, P. 218-231.
- (2) S. Horikiri, K. Tsuji, Y. Abe, A. Fukui and E. Ichiki, Japan Patent 49-108325, 1974.
- (3) W. Mahler and M.F. Bechtold, *Nature*, **285**, 27 (1980).
- (4) T. Maki and S. Sakka, *J. Mater. Sci. Lett.*, **5**, 28 (1986).
- (5) T. Maki and S. Sakka, *J. Non-Cryst. Solids*, **82**, 239 (1986).
- (6) T. Maki, Y. Teranishi, T. Kokubo and S. Sakka, *J. Ceram. Soc. Japan*, **93**, 387 (1985).
- (7) T. Kokubo, Y. Teranishi and T. Maki, *J. Non-Cryst. Solids*, **56**, 411 (1983).
- (8) G.A. Parks, *Chem. Rev.*, **65**, 177 (1965).
- (9) M.C. Flemings, "Solidification Processing", McGraw-Hill, New York (1974) P. 58.
- (10) A.F. Wells, "Structural Inorganic Chemistry", 5th Ed., 1984, P. 641.