

Title	Efficiency Calculation and Measurement of Large NE213 Neutron Counter (Commemoration Issue Dedicated to Professor Sakae Shimizu on the Occasion of his Retirement)
Author(s)	Higo, Toshiyasu; Matsuki, Seishi; Iwashita, Yoshihisa; Okihana, Akira; Fujiwara, Noboru; Yanabu, Takuji
Citation	Bulletin of the Institute for Chemical Research, Kyoto University (1979), 57(1): 13-22
Issue Date	1979-03-31
URL	http://hdl.handle.net/2433/76822
Right	
Type	Departmental Bulletin Paper
Textversion	publisher

Efficiency Calculation and Measurement of Large NE213 Neutron Counter

Toshiyasu HIGO, Seishi MATSUKI, Yoshihisa IWASHITA,
Akira OKIHANA[†], Noboru FUJIWARA^{††}, and Takuji YANABU*

Received October 4, 1978

A 14 cm diameter and 19 cm depth counter with liquid scintillator (NE213) was constructed for the fast neutron detection. Design, performance and efficiency calibration are described. Calculated efficiency and experimental efficiency are compared at low energy region. They agree within about 20%.

KEY WORDS Large neutron counter /Its efficiency calibration/

I. INTRODUCTION

Efficiency calibration of a neutron counter is an old and new problem. For thin neutron counters which detect neutrons up to 8 MeV, a simple analytical calculation of total efficiency gives good agreement¹⁾ with the experimental one. However, for thick neutron counters, the effect of multiple scattering dominates and the simple analytical calculation gives poor predictions.²⁾

For small counters, Verbinski *et al.*³⁾ developed a Monte Carlo calculation code to give the response function of a neutron counter with the NE213 liquid scintillator, and the agreement between the prediction and the experimentally determined one was good.⁴⁾

In this paper, we report the neutron efficiency calculated by applying the Verbinski's principle to our counter and also we report the calibration of the counter at low energies. This counter was constructed for the detection of neutrons from the (π^- , n) reactions on various materials. The experiment was performed by using the 500 to 1500 MeV/c π^- beam of the National Laboratory for High Energy Physics (KEK).⁵⁾

II. CONSTRUCTION OF A NEUTRON COUNTER

The design principle of the counter is as follows;

- (1). to discriminate gamma rays from neutrons, the liquid scintillator NE213 should be used.
- (2). to detect neutrons of 100 MeV with 20% efficiency, the depth of the scintillator should be greater than 15 cm.

* 肥後寿泰, 松木征史, 岩下芳久, 沖花 彰, 藤原 昇, 柳父琢治: Institute for Chemical Research, Kyoto University, Kyoto.

[†] Present Address; Kyoto University of Education, Kyoto.

^{††} Present Address; Nara Women's University, Nara.

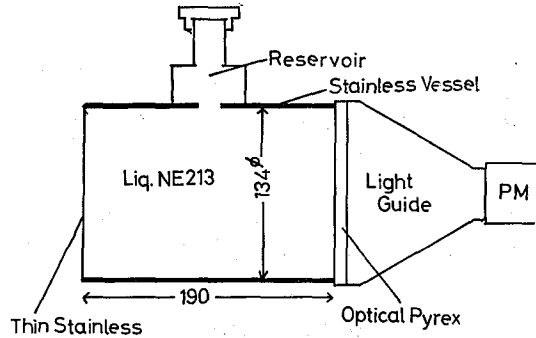

Fig. 1. Cross section and dimensions of the neutron counter.

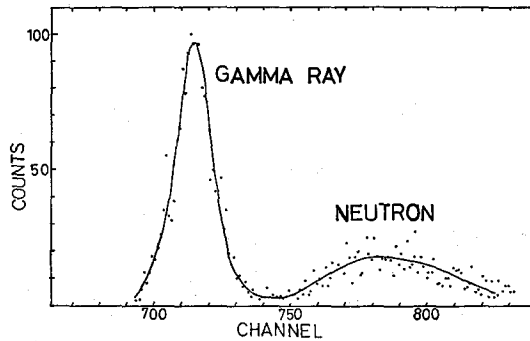

Fig. 2. Zero crossing time distribution of NE213 liquid scintillator with Ra-Be neutron source.

- (3). to construct the counter economically, only one photomultiplier should be used. Therefore, the scintillation light should be led to the photomultiplier via a light guide.
- (4). to make the counter feasible to detect charged particles, window of the counter should be as thin as possible.

Cross section and dimensions are shown in Fig. 1. The liquid scintillator NE213 of 2.7 l was filled in the vessel. Not to degrade the characteristics of neutron-gamma ray discrimination, care was taken to protect the scintillator from oxygen, that is, the vessel was filled with Ar gas and then the NE213 was poured into the vessel. The inside wall of the vessel was coated with TiO_2 paint and the light guide was wrapped with thin Al foil to raise the light collection efficiency. The photomultiplier used is 56DVP. Time resolution was measured to be less than 3.6 ns for gamma rays.

Neutron-gamma ray discrimination was tested with a Ra-Be neutron source. The energy threshold was fixed at 2.3 MeV. The result is shown in Fig. 2. Though the scintillator volume is large, the discrimination is good in this low energy region.

III. EFFICIENCY CALCULATION

The FORTRAN program for the calculation of neutron counter efficiency developed

by Verbinski *et al.* is called O5S.⁶⁾ Yoshida *et al.*⁷⁾ have developed a program for the efficiency calculation based on the algorithm of the program O5S. Some differences exist between the O5S and that of Yoshida, which we call Code 1 hereafter, as the following.

- (1). For the $^{12}\text{C}(n, n)^{12}\text{C}$ elastic scattering, simplified pattern of angular distribution is used in O5S and is parametrised, but in Code 1, Legendre polynomial expansion is applied to express the angular distribution.
- (2). For the reaction $^{12}\text{C}(n, pn)^{11}\text{B}$ and $^{12}\text{C}(n, 2n)^{11}\text{C}$, the distribution of first emitted particle is assumed $p(\theta) = 2 - \theta/\pi$ in the c. m. system in O5S, but in Code 1, isotropic distribution in the c. m. system is assumed.
- (3). The spreading of light output due to the fluctuations of light collection efficiency, photomultiplier gain and so on are taken into account in O5S, and Gaussian distribution of light output is assumed, but in Code 1, no attention is paid to these fluctuations.

We improved further Code 1 and developed a new version, which we call Code 2, to calculate the counter efficiency. The main improvements are as follows;

- (1). Energy spread of the incident neutron beam is taken into account by assuming the Gaussian distribution.
- (2). Finite resolution of the light output is taken into account. The actually observed light output distribution is assumed to be Gaussian. The standard deviation $\sigma^{(2)}$ of light output is given by

$$\sigma = L_0(L/L_0 + 0.5)^{1/2} \quad (1)$$

where L_0 is a parameter determined experimentally, and L is the light output given by the relation between light output and energy loss³⁾ (Fig. 3). Unit of L_0 and L is defined by the 1.28 MeV gamma ray Compton edge of ^{22}Na . The light output is then calculated using the Neumann's method for each incident neutron.

- (3). In Code 1, neutrons are assumed to enter the detector in parallel. In our experiment, the neutron source is defined inside the circle of 1 cm diameter, and the

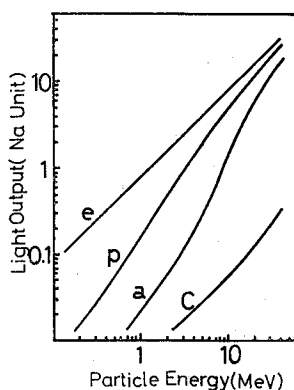

Fig. 3. Relations between light output and charged particle energy loss in scintillator NE213.³⁾ One unit of light output is defined by the light output pulse corresponding to the Compton edge of 1.28 MeV gamma-rays from ^{22}Na source.

neutron counter, of which the diameter is 14 cm, is located at about 1 m apart from the neutron source. Therefore, the divergence of the neutron beam is taken into account in our program.

In Table I are listed the cross sections, light output yield and proton ranges in NE213 which are used in our calculation. These values are almost the same as those in O5S.

An example of efficiency curve of the neutron counter calculated by Code 2 is shown in Fig. 4. In this calculation, the distance between the neutron source and the neutron counter is one meter. Point neutron source is assumed. Time resolution of the time of flight system is 3.6 ns FWHM, so that the neutron beam is assumed to have an energy spread corresponding to this time resolution around the specified value of the

Table I. References of Cross Section Data Used in Code 2

		Reference	Energy MeV	
H	σ	ENDF/B	0~14	
		O5S Library	14~100	
	$d\sigma/d\Omega$	O5S Library	13.7~62.5	
C	σ^{total}	KFK-750	0~10	
		ENDF/B	10~14	
		O5S Library	14~100	
	σ^{el}	KFK-750	0~10	
		ENDF/B	10~14	
		O5S Library	14~100	
	$d\sigma/d\Omega$	O5S Library		
	$\sigma^{in el}$	KFK-750	0~14	
		ENDF/B	10~14	
		O5S Library	14~100	
		$d\sigma/d\Omega$	Isotropic	
		$\sigma_{n,\alpha}$	O5R Library	0~14
			O5S Library	14~
		$d\sigma/d\Omega$	isotropic	
$\sigma_{n,n3\alpha}$		O5R Library	0~14	
	O5S Library	14~		
$\sigma_{n,p}$	O5S Library			
$\sigma_{n,pn}$	O5S Library			
$\sigma_{n,2n}$	O5S Library			

Energy Loss-Light Yield Data	O5S Library
Proton Range Data	O5S Library

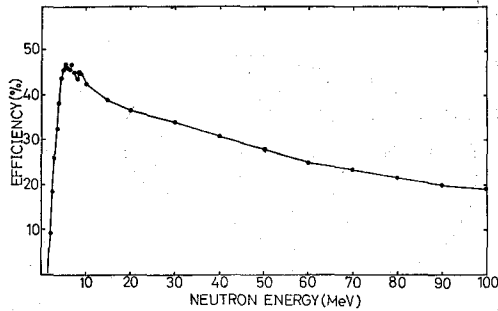

Fig. 4. Efficiency calculated by Code 2 up to 100 MeV.

neutron energy. Parameter L_0 is fixed to 0.1. Neutron threshold energy is 2.35 MeV. Number of trial is 10000 and calculation time for one neutron energy is about 25 seconds using FACOM M190.

IV. EFFICIENCY DETERMINATION

This experiment aims to estimate the efficiency of the neutron counter set at the same geometry as used in the (π^-, n) experiment. Therefore, the neutron counter was set at 1 m apart from the target. Experimental setup is shown in Fig. 5.

The commonly used reaction

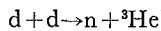

was used to determine the efficiency. Deuteron beams from the Kyoto University Cyclotron ($E_d=14$ MeV), and from the Van de Graaff accelerator ($E_d=4$ MeV) were used. Deuterated polyethylene, $(\text{CD}_2)_n$, was used as a target and its thickness was $400 \mu\text{g}/\text{cm}^2$ or $50 \mu\text{g}/\text{cm}^2$.

${}^3\text{He}$ detector, a 9 mm diameter SSD, was set 45 mm apart from the target. To make sure the neutron- ${}^3\text{He}$ coincidence, ${}^3\text{He}$ detector should cover the angular range of ${}^3\text{He}$ associated with neutrons which enter into the neutron counter. An example of angular range covered by the SSD is shown in Fig. 6. Dotted circle in the figure shows the angular range of the associated ${}^3\text{He}$ and circle of 2, 3, and 4 show the angular range subtended by the SSD. As seen from the figure, the SSD covers the area of ${}^3\text{He}$ even if the deuteron beam changes its position. Experimentally, the neutron counter is set for the moment at some polar angle and then the ${}^3\text{He}$ detection angle is varied to survey the relevant polar angle by observing the variation of the coincidence rate.

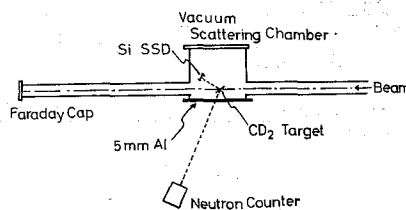

Fig. 5. Experimental setup for efficiency determination.

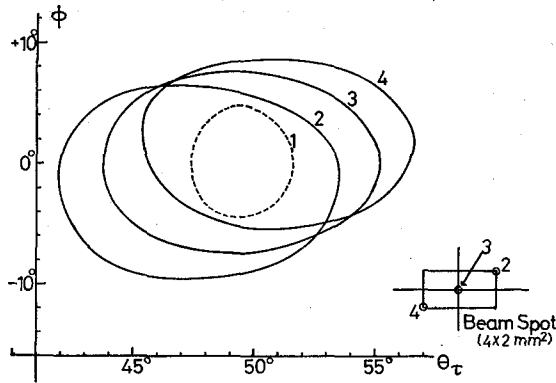

Fig. 6. Area 1 describes the angular range of ^3He associated with neutrons which enter into the neutron counter. Area 2 (or 3, 4) describes the angular range subtended by SSD if beam spot position is at 2 (or 3, 4) in the beam spot.

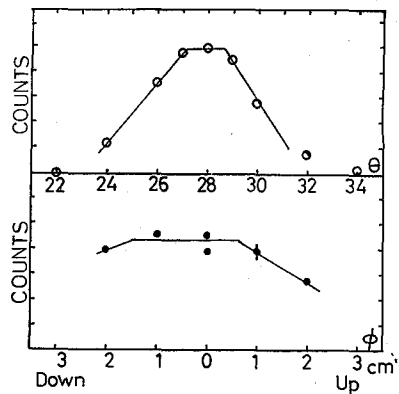

Fig. 7. \circ Coincidence rate as a function of θ , the angle of SSD to the deuteron beam direction.
 \bullet Coincidence rate as a function of azimuthal angle ϕ of the neutron counter.

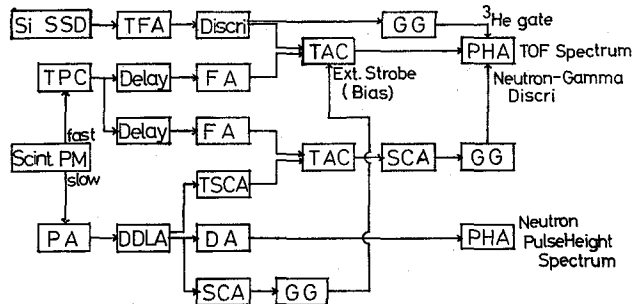

Fig. 8. Block diagram for efficiency determination experiment.

Then the neutron counter is moved azimuthally to fix the position by observing the variation of coincidence rate. These conditions are shown in Fig. 7.

Electronic block diagram is shown in Fig. 8. The detection threshold of the neutron counter was set at 2.35 MeV. For this purpose, we measured first the light output of the neutron counter from the gamma-ray source of ^{60}Co and ^{137}Cs . And then the constant k and α in the following relation was estimated from the light output corresponding to the Compton edge of gamma-rays in these sources.

$$\text{Light output} = k \times (\text{electron energy loss})^\alpha.$$

Second, the experimental relation³⁾ between the proton energy loss and light output for the NE213 was used to determine the bias energy. (see Fig. 3) The light output resolution was determined as shown in Fig. 9 by using the 6 MeV neutron beam. Parameter L_0 in Eq. (1) was determined to be 0.1. The efficiency was determined as follows;

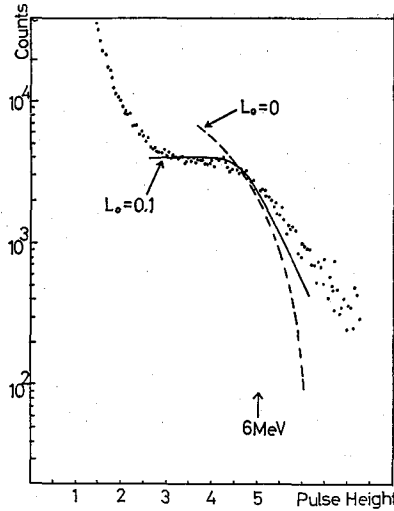

Fig. 9. Dot ; experimental pulse height distribution of 6 MeV neutrons.
 Broken line ; response function calculated by code 2, $L_0=0$.
 Solid line ; response function calculated by code 2, $L_0=0.1$.

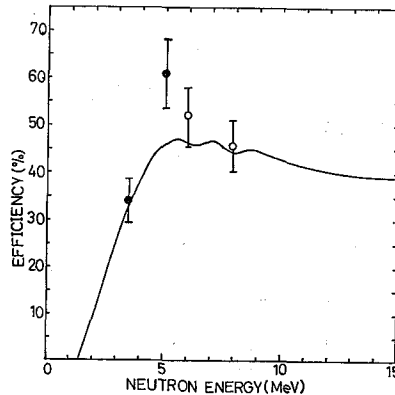

Fig. 10. Total efficiency determined experimentally.
 solid line ; efficiency calculated by Code 2.

Table II. Error Summary of Efficiency Determined Experimentally

$E_d=14$ MeV Cyclotron beam			$E_d=4$ MeV Van de Graaff beam		
E_n (MeV)	θ_n (lab)	ΔE_n (MeV)	E_n (MeV)	θ_n (lab)	ΔE_n (MeV)
5.9	90°	≤ 0.9	3.4	90°	≤ 0.38
7.9	75°	≤ 1.2	5.0	60°	≤ 0.45

%	Considered errors	%
≤ 3	Counting statistics	≤ 3
≤ 3	Target thickness estimation*	≤ 3
≤ 3	D(d, n) ³ He reaction cross section**	≤ 10
≤ 1	Integrated beam charge	≤ 1
≤ 2	Solid angle error	≤ 2
≤ 1	Al absorption error***	≤ 1
≤ 10	Error caused by bias setting error	≤ 5
≤ 12	Estimated total error	≤ 12

* Error in d-d elastic scattering cross section data^{9,10} to estimate target thickness
 ** Error in D(d, n)³He reaction cross section data.¹¹
 For $E_d=4$ MeV, this cross section was estimated using interpolated data of Legendre expansion coefficients for angular distribution of the cross section.
 *** Errors in estimating neutron flux attenuation by Al wall of the chamber. This error arises from neutron total cross section data¹² for Al.

$$\epsilon_{exp} = (\text{number of coincidence counts}) / (\text{neutron flux into the neutron counter})$$

The experimental results of the total efficiency are shown in Fig. 10. Errors and other parameters are listed in Table II.

V. DISCUSSIONS

In Fig. 9 are shown the neutron pulse height spectrum together with the prediction by Code 2. As seen in the figure, light output resolution should be taken into account in the Monte Carlo calculation. The efficiency calculated with and without the light output resolution are shown in Fig. 11. Light output resolution was fixed as $L_0=0.1$

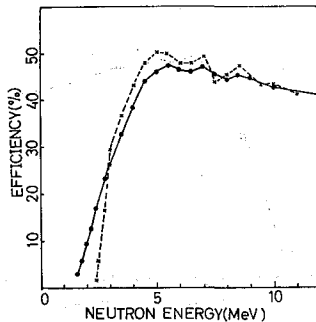

Fig. 11. • (x) Efficiency calculated by Code 2. Finite (infinite) resolution of incident neutron energy and light output is assumed.

Efficiency Calculation and Measurement of Neutron Counter

Table III. Dependence of Efficiency on Neutron Bias Energy. ϵ_{exp} is Efficiency Determined Experimentally and ϵ_{calcul} is the One Calculated by Code 2

En (MeV)	Bias (MeV)	ϵ_{exp} (%)	ϵ_{calcul} (%)
3.44	2.0	49	39
	2.35	32	32
	2.7	28	24
5.0	2.0	59	51
	2.35	58	46
	2.7	48	40

hereafter. Figure 4 shows the efficiency curve in the energy range up to $E_n = 100$ MeV.

Comparison is made in Fig. 10 between the experimentally determined efficiency and calculated one with Code 2. In Table III are shown the dependence of efficiency on neutron bias energy. The experimentally determined efficiency and calculated one are listed. The calculated values are in moderate agreement with those of experimental ones.

Experimental efficiency estimation of such a large counter is rather scarce. At about 76 MeV, Narboni⁸⁾ reported the agreement between calculation and experiment less than 10%. Love *et al.*⁴⁾ reported the comparison of response function between calculation and experiment at about 2.7 MeV and 14 MeV, and got agreement less than 10%. From these results, including our experiment, Monte Carlo calculation can predict neutron efficiencies which agree with experiments less than 20% up to 100 MeV.

ACKNOWLEDGMENTS

We would like to acknowledge Dr. K. Shin and his collaborators for offering us the Monte Carlo program and for kind suggestion. We would like also to thank Professor H. Itoh for the arrangements of this experiment. The (π^-, n) reaction experiment was done with the collaboration of Saga University, Kyushu University and the Institute for Chemical Research, Kyoto University. The authors would like to acknowledge the collaborators for their encouragement of this work. Thanks are also due to the crews of the cyclotron and Van de Graaff accelerator of Kyoto University for their kind cooperation. The calculation was done with FACOM M190 at the Data Processing Center, Kyoto University and with Central Computer HITAC8800 at Data Handling Division of National Laboratory for High Energy Physics (KEK).

REFERENCES

- (1) Eberhard Finckh in "Nuclear Spectroscopy and Reactions (Part B)," J. Cerny Ed., Academic Press, New York and London, 1974, p. 573.
- (2) Noel R. Stanton, COO-1545-92 (1971), unpublished
- (3) V. V. Verbinski, W. R. Burrus, T. A. Love, W. Zobel, N. W. Hill, and R. Textor, *Nucl.*

T. HIGO, S. MATSUKI, Y. IWASHITA, A. OKIHANA, N. FUJIWARA, and T. YANABU

Instr. & Meth. **65**, 8 (1968).

- (4) T. A. Love, R. T. Santoro, R. W. Peele, and N. W. Hill, *Rev. Sci. Instr.* **39**, 541 (1968).
- (5) to be published.
- (6) R. E. Textor and V. V. Verbinski, ORNL-4160, unpublished
- (7) M. Yoshida, master's thesis, Kyoto Univ. (1976), unpublished
- (8) Ph. Narboui, Ph. N. 70-12, ORSAY, unpulished
- (9) A. S. Wilson, M. C. Taylor, J. C. Legg, and G. C. Phillips, *Nucl. Phys.*, **A126**, 193 (1969).
- (10) J. E. Brolley, Jr., T. M. Putman, L. Rosen, and L. Stewart, *Phys. Rev.*, **117**, 1307 (1960).
- (11) J. E. Brolley, Jr., T. M. Putman, and Louis Rosen, *Phys. Rev.*, **107**, 820 (1957).
- (12) BNL325, 3rd ed, Vol II (1976).