

Title	Study on Geometrical Stability of a Multi-Anvil High Pressure Device by Gamma Rays (Special Issue on Physical, Chemical and Biological Effect of Gamma Radiation, XIII)
Author(s)	Nagatomo, Tsuneto; Mazaki, Hiromasa; Shimizu, Sakae
Citation	Bulletin of the Institute for Chemical Research, Kyoto University (1972), 50(1): 1-7
Issue Date	1972-03-31
URL	<a href="http://hdl.handle.net/2433/76404">http://hdl.handle.net/2433/76404</a>
Right	
Type	Departmental Bulletin Paper
Textversion	publisher

## Study on Geometrical Stability of a Multi-Anvil High Pressure Device by Gamma Rays

Tsuneto NAGATOMO, Hiromasa MAZAKI and Sakae SHIMIZU\*

Received December 25, 1971

Geometrical stability of a multi-anvil (eight-anvil) high pressure apparatus has been investigated by the use of  $\gamma$ -ray emitter ( $^{99m}\text{Tc}$ ) embedded at the center of the device. Minute changes in the geometry of the apparatus continued throughout the period of operation. Modifications of the apparatus to improve the stability as well as the detection efficiency for  $\gamma$  rays from the embedded source are described.

### I. INTRODUCTION

There are two kinds of stability which should be considered as important characteristics of a high pressure apparatus used for experimental work in solid state physics or others. One is the stability of a generated hydrostatic pressure and the other the stability of the geometry or construction of the apparatus in operation. Since the stability of generated pressure is naturally essential for investigations under a high pressure, many workers<sup>1)</sup> have focussed their attention on this subject and measured hysteresis of pressure yield versus applied oil pressures. From their results it seems to be plausible to conclude that a hydrostatic pressure generated in a high pressure device is in general quite stable for practical purposes, even if there is some decrease of the oil pressure during operation.

On the contrary, the geometrical stability of a high pressure apparatus has been considered to be of minor importance. For example, in the usual experiment with a pressure generator for measuring phase changes of a metallic sample under a high pressure,<sup>2)</sup> a slight change in the geometry of the apparatus does not cause a significant error in the measurements.

In some cases, however, the geometrical stability becomes the most critical factor and gives rise to crucial effects. To illustrate this situation, let us consider a nuclear decay caused by the interaction between a nucleus and surrounding shell electrons, *i. e.*, either an orbital electron capture decay or a partly converted isomeric transition of a nucleus. The effect of high pressure on this type of nuclear decay can be studied by observing  $\gamma$  rays emitted from a sample embedded in a high pressure device and by analyzing the decay probability which depends on the charge density of shell electrons at the nucleus.<sup>3-6)</sup> In this experiment, the observed counting rates of  $\gamma$  rays depend explicitly on the geometrical detection efficiency. Furthermore, in most cases which have been studied at the present stage, the effect of high pressure on a nuclear decay is quite small, *i. e.*, a relative

\* 長友 恒人, 間崎 啓匡, 清水 榮: Laboratory of Nuclear Radiations, Institute for Chemical Research, Kyoto University, Kyoto.

change in decay probabilities is of the order of  $10^{-3}\sim 10^{-4}$ . To perform reliable measurements, therefore, the geometrical stability of a high pressure apparatus is of particular importance in such a case.

With the use of a multi-anvil (eight-anvil) high pressure device, developed by Kawai<sup>7)</sup> and modified in some details, the geometrical stability of the device has been studied at a pressure of 100 kbar. The main modification of the apparatus made was to improve the geometrical stability and the solid angle for  $\gamma$ -ray detection. In the present paper, we wish to report details of the experiment as well as some characteristics of the multi-anvil high pressure apparatus used.

## II. CONSTRUCTION OF HIGH PRESSURE DEVICE

In Fig. 1 are shown the details of the construction of the present high pressure device. The main construction consists of eight anvils (not shown in the figure), three cylinders, and an iron frame in which the cylinders are contained.

Each of the anvils has two components, a hardened iron section and a well-sintered tungsten carbide section containing a few percent cobalt (Fig. 2). Four anvils compose a cone with small spacers between neighboring anvils, four side boards and a cap (Fig. 3). Since the top of tungsten carbide section of each anvil is truncated so as to have a front face of an equilateral triangle having sides of 1.8 mm, an octahedral hollow space is formed at the center when all anvils are

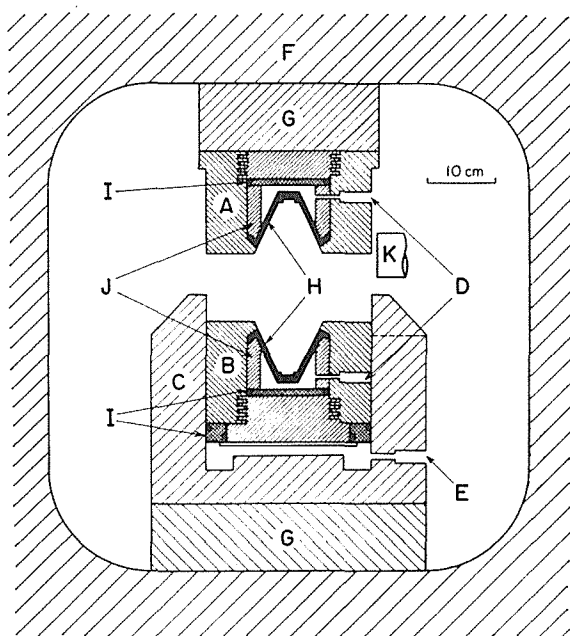

Fig. 1. The construction of the multi-anvil high pressure device: (A and B) inner cylinders; (C) outer cylinder; (D) oil inlets of inner cylinders; (E) oil inlet of outer cylinder; (F) iron frame; (G) iron bases for cylinders; (H) rubber caps which shield the cylinder oil as well as hold the anvils (not shown in the figure); (I) oil shields made of nylon gaskets and rubber O-rings; (J) iron cylinders to hold the rubber caps; (K) probe containing NaI (Tl) scintillator, photomultiplier, and preamplifier.

Geometrical Stability of a Multi-Anvil High Pressure Device

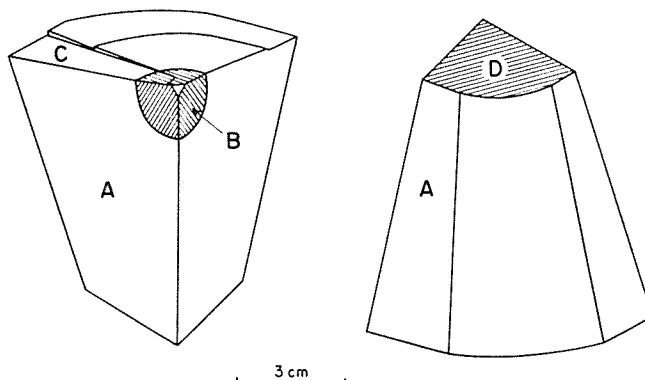

Fig. 2. Anvil: (A) hardened iron section; (B) tungsten carbide section with truncated top; (C) small opening to obtain a larger  $\gamma$ -ray detection efficiency; (D) lead plate of 0.5 mm thickness.

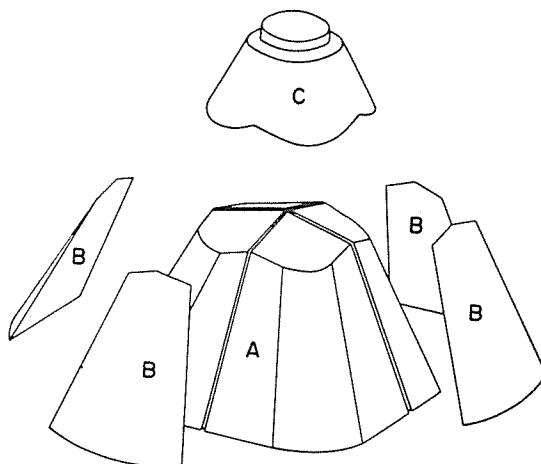

Fig. 3. Cone which consists of four anvils (A), four side boards (B), and a cap (C). Both (B) and (C) are made of iron.

put together. In the hollow space is inserted an octahedron of pyrophyllite (hydrous aluminum silicate) formed from two pieces and containing a radioactive sample at the center. The cones with the octahedral pyrophyllite are then mounted in thick rubber caps which shield the cylinder oil as well as hold the cones at the proper position in the assembly.

As demonstrated in Fig. 1, cylinders A and C are fixed on the iron frame which can withstand a maximum load of 900 tons. For taking in or out the anvils, cylinder B can move upward and downward in cylinder C. There are two independent oil systems, one connected in parallel to the inner cylinders, A and B, and the other to cylinder C. These systems are fitted with pressure-recording units to control and monitor oil pressures. After two cones are mounted in the inner cylinders, cylinder B is elevated until the space between the two inner cylinders becomes 5 mm. The two pumps (maximum available pressure, 700 kg/cm<sup>2</sup>) are operated alternately until a pressure of 100 kbar is generated at

the center of the octahedron. When the cylinder oil pressure is elevated, the cones are squeezed toward the center until the force causing the outward flow of the central pyrophyllite is balanced with the internal shearing stress of the assembly. In this process, the octahedral pyrophyllite at the center is compressed and part of it becomes a gasket between the neighboring anvils preventing out-flow of the inside material. As the formation of the proper gasket is definitely necessary, the size of the pre-compressed central octahedron should be larger than that of the hollow space at the center of the cones. However, a larger octahedron results in a greater loss of hydrostatic pressure. Taking into consideration these facts, it was found that the octahedron with edges of 3.7 mm was suitable for the present device. At the final stage of compression, the slit between two inner cylinders was decreased to about 3.5 mm.

### III. PRESSURE CALIBRATION

The method of pressure calibrations is based on the phase transitions of Bi I-II, Bi III-V, and Sn I-II which correspond to 25.2, 77.0, and 100 kbar, respectively. In an actual procedure of pressure calibration for the present apparatus, a thread of bismuth or tin was sandwiched between two pieces of pyrophyllite which together formed an octahedron and then changes in electrical resistance of the thread caused by the phase transitions were measured. It was found that the oil pressure in the inner cylinders versus the generated hydrostatic pressure has almost a linear relation and that a pressure of 100 kbar is achieved at an oil pressure of  $520 \pm 50$  kg/cm<sup>2</sup>. The reproducibility of measurements is rather poor, but this seems to be unavoidable since in each measurement the anvils are put in place by hand. In the calibration, it was also revealed that the slope of this linear relation is appreciably affected by the size of the spacers placed between neighboring anvils. To obtain maximum reproducibility of pressure generation, therefore, one has to use the same size of spacers in each measurement.

### IV. GEOMETRICAL STABILITY

A conventional and sensitive method for detecting small changes in the geometry of the high pressure apparatus involves measurements of radioactive rays generated from the center of the assembly. Since the observed counting rate of radioactive rays from the central source are crucially affected by the geometrical detection efficiency, the measurement gives direct information on a change in the geometry, if other experimental factors involving the stability of the electronic circuits connected to the detector, are maintained sufficiently stable.

In the present experiment, a point source of <sup>99m</sup>Tc was used as a radioactive source to be embedded in the pressure transmitting medium made of pyrophyllite and mounted at the center of the assembly. The <sup>99m</sup>Tc source emits the 140-keV  $\gamma$  rays immediately following the isomeric transition. The reasons of using <sup>99m</sup>Tc are: (a) the half life of the nucleus is 6.04 hours and consequently permanent contamination of the surroundings will be avoided if there is an accidental "burst" of the compressed sample, and (b) the decay scheme is simple and only

the 140-keV  $\gamma$  rays are emitted.

The  $^{99m}\text{Tc}$  solution was obtained by milking a commercial generator containing the longer lived parent of  $^{99}\text{Mo}$  with an initial intensity of 100 mCi. Technetium as pertechnetate ions was eluted with a solution of NaCl. As the source to be compressed was desired to be essentially weightless, a salt-free solution was prepared by chemical treatments<sup>6)</sup> before the final source preparation. With the condensed radioactive solution of  $^{99m}\text{Tc}$  obtained by evaporating the salt-free solution almost to dryness, a point source of  $^{99m}\text{Tc}$  with an initial intensity of about 10 mCi was prepared at the center of the octahedral pyrophyllite. The octahedron was then inserted to the central hollow space of the anvils and compressed at a pressure of 100 kbar by the process described in Sec. II.

The counting rates of the 140-keV  $\gamma$  rays were measured by a NaI(Tl) scintillation detector (1.5 inch diam by 1 inch thick) set outside the pressure apparatus and connected to a Toshiba 7696 photomultiplier and an ordinary electronic counting system. To achieve good statistics, the counting rate at time  $t$  was obtained as an average value of the total count accumulated for 28 min and this counting procedure was repeated for 15 hours. If there is no geometrical instability in the assembly, the counting rates, corrected for decay and dead time of the counting system, should show a horizontal straight line as a function of time.

At the early stage of the experiment, however, the observed counting rates of the  $^{99m}\text{Tc}$  source versus time showed, after the corrections, no horizontal straight line, but long term instability ranging up to a few percent over the statistical errors. As the stability of the counting system was proved to be stable within the statistical errors of the observed counting rates, the appeared instability was thought to be caused by a change in the geometrical detection efficiency. This view of a geometrical change of the assembly was carefully checked. It was found that the side boards of the anvils shown in Fig. 3 shifted slightly during the course of compression and the resulting asymmetry gave rise to the instability of the whole assembly.

Thus, various modifications of the assembly were attempted in vain. Finally each side board was attached by Araldite to one of the anvils and then a side board-anvil pair was used as a unit component of the cones. By this modification, the shift of the side board during compression was avoided and consequently the geometry of the assembly was found to become satisfactorily stable after several hours of compression. The above mentioned modification required about 20 % more oil pressure than for the original construction of the assembly. For a pressure of 100 kbar, one had to supply an oil pressure of more than 600 kg/cm<sup>2</sup>, which was too high for long term operation of the oil system. In order to compensate the extra oil pressure required by the modification, the spacers between neighboring anvils were made as small as possible to minimize the loss of pressure by the spacers.

In Fig. 4 is illustrated the counting rate of the  $\gamma$  rays from the central source measured using this modified assembly. As seen in the figure, the counting

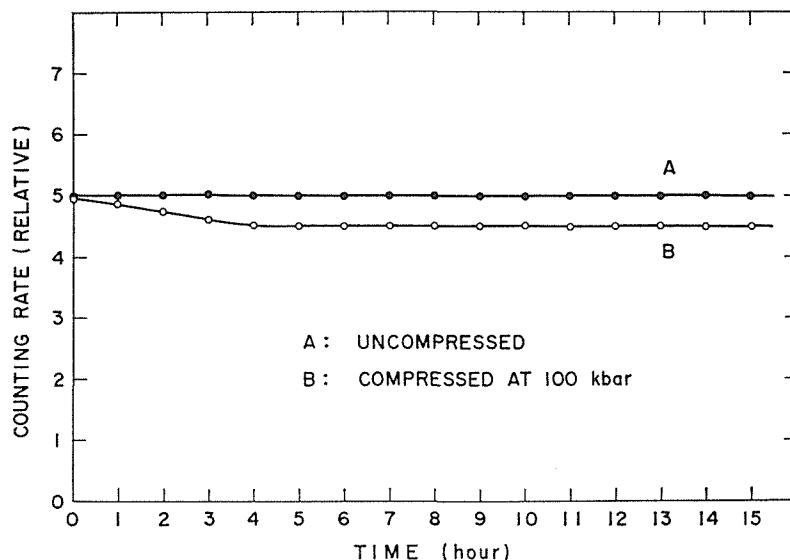

Fig. 4. Geometrical stability of the high pressure device ( $^{99m}\text{Tc}$  source). Data are corrected for decay and dead time of the counting system. For comparison, observed counting rates of the standard uncompressed  $^{99m}\text{Tc}$  source are also shown. Statistical errors are less than 0.02 %.

rate, which in this case corresponds to the geometrical detection efficiency, still decreases over the initial period. This decrease may be due to the essential characteristic of the present type of high pressure device with the thick rubber caps. Regardless it was proved that after several hours the assembly was geometrically stable within the statistical counting error, 0.02 %.

## V. DETECTION EFFICIENCY

When the cones are squeezed toward the center by elevating the oil pressure in the cylinders, the detection efficiency of the NaI(Tl) scintillator set outside the assembly (Fig. 1) is decreased because the slit through which the  $\gamma$  rays can come out becomes narrower as the cones are squeezed.

It is of importance to know the total detection efficiency  $\epsilon$ , involving both geometrical and intrinsic, because in any experiment the intensity of the source to be embedded at the center of the assembly must be determined in compliance with  $\epsilon$ . Determination of the efficiency  $\epsilon$  was performed with  $^{99m}\text{Tc}$  sources (200~300  $\mu\text{Ci}$ ) of which absolute intensities were previously determined by a usual method. It was found that the total detection efficiency was very small and decreased rather rapidly as the hydrostatic pressure increased. At a pressure of 100 kbar the value of  $\epsilon$  is about  $1.2 \times 10^{-5}$ . Such a small value of  $\epsilon$  should place severe limitations on experimental work with the apparatus.

In order to improve the value of  $\epsilon$ , we modified the anvils so as to increase the solid angle for the detector. The small opening (denoted as C in Fig. 2) prepared for this purpose was found to be quite effective in improving  $\epsilon$ . Although this geometrical modification gives only about 1.3 times larger counting rate at

## Geometrical Stability of a Multi-Anvil High Pressure Device

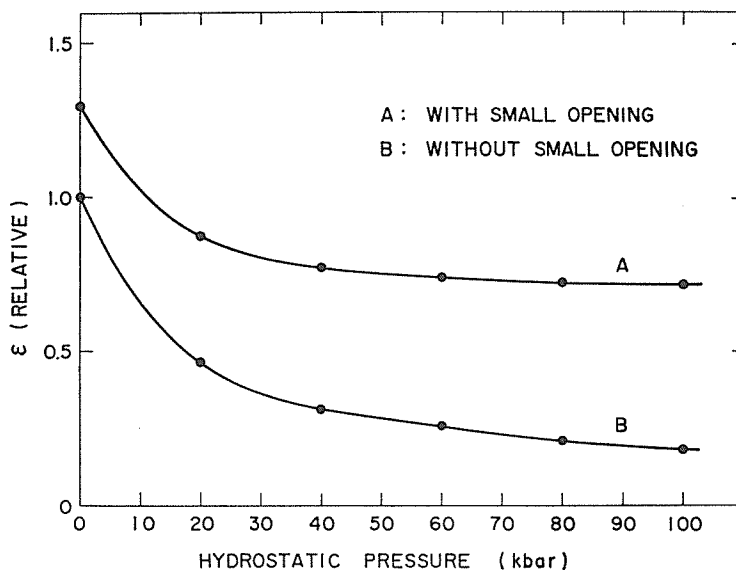

Fig. 5. Relative change of the total detection efficiency,  $\epsilon$ , versus hydrostatic pressure. Statistical errors are less than 1%.

an atmospheric pressure,  $\epsilon$  becomes at 100 kbar about 4 times larger than that for the original anvils without the small opening. Relative changes in  $\epsilon$  versus hydrostatic pressure are shown in Fig. 5 for both cases, with and without the small opening. It should be mentioned that the small opening often causes "burst" of the central material because of the geometrical asymmetry at the center. To prevent an accidental "burst" it is a convenient method to compensate the small opening by incorporating a material of low atomic number, for example Araldite, through which  $\gamma$  rays can easily pass.

### ACKNOWLEDGMENT

The authors wish to express their thanks to Professor N. Kawai for his stimulating discussions on setting up the high pressure device. Thanks are also due to Dr. M. Koyama and M. Nishi for their kind help in preparing  $^{99m}\text{Tc}$  sources.

### REFERENCES

- (1) See, *e. g.*, J. Osugi, K. Shimizu, K. Inoue, and K. Yasunami, *Rev. Phys. Chem. Japan*, **34**, 1 (1964).
- (2) See, *e. g.*, N. Kawai and S. Endo, *Rev. Sci. Inst.*, **41**, 1178 (1970).
- (3) K. T. Bainbridge, *Chem. Eng. News*, **30**, 654 (1952).
- (4) W. B. Gogarty, S. S. Kistler, and E. B. Christiansen, *Office of Naval Research Technical Report VII*, Contract No. 1288 (02), Project No. Nr-052-357 (1963).
- (5) J. A. Cooper, Thesis, University of California, UCRL-16910 (1966) unpublished.
- (6) H. Mazaki, T. Nagatomo, and S. Shimizu, *Phys. Rev. C*, May 1972, in press.
- (7) N. Kawai, *Proc. Japan Acad.*, **42**, 385 (1966).