

Title	Nondestructive Determination of Silicon (Silica) in Marine Sediments by Fast Neutron Activation (Physical and Inorganic Chemistry)
Author(s)	Shigematsu, Tsunenobu; Fujino, Osamu; Honjo, Takaharu
Citation	Bulletin of the Institute for Chemical Research, Kyoto University (1968), 45(4-5): 299-306
Issue Date	1968-01-20
URL	http://hdl.handle.net/2433/76211
Right	
Type	Departmental Bulletin Paper
Textversion	publisher

Nondestructive Determination of Silicon (Silica) in Marine Sediments by Fast Neutron Activation

Tsunenobu SHIGEMATSU, Osamu FUJINO and Takaharu HONJO*

(Shigematsu Laboratory)

Received July 10, 1967

Silica in marine sediment samples were determined by 14 MeV neutron activation. Powdered sample (1 g) was irradiated in the neutron flux of about 2×10^5 n/cm²·sec., gamma-rays spectrum of the 2.27 min. ²⁸Al was measured and the decay of the 1.78 Mev photo-peak was followed. The results agreed with the value colorimetrically obtained, showing error of about 5%.

INTRODUCTION

The thermal neutron activation analysis is a very sensitive method and widely used for the trace analysis. However, it has been recognized that the method is not so suitable for the determination of light elements, because of the remarkably small activation cross sections. Since 14 MeV neutrons were used for the determination of silicon and aluminium¹⁾ in 1956, and of oxygen in beryllium²⁾ in 1958, the fast neutron activation technique was developed rapidly. The reason for this rapid development may be chiefly owing to the facts that 14 MeV neutrons are simply produced by the T-D reaction with a easy-to-operate, inexpensive neutron generator, and the various nuclear reactions such as (n, p), (n, α), (n, 2n) reactions are induced by the fast neutron bombardment.

Although the sensitivities of the 14 MeV neutron activation analysis for various elements were calculated^{3,4)} or experimentally obtained^{5,6)}, and the determination of rare earth metals⁷⁾ was reported, this technique should be more attractive for the analysis of light elements, especially for the determination of oxygen^{8~17)}. Besides the element, nitrogen¹⁸⁾, magnesium¹⁹⁾, aluminium^{1,19)}, and silicon^{1,19~21)} were also analysed.

In this research, the nondestructive determination of silicon (silica) in marine sediment samples were attempted by means of a sealed-off type, low level neutron generator with the flux of about 2×10^5 n/cm²·sec., and the analytical results were compared with the value obtained colorimetrically by the molybdenum yellow method. Silicon can be determined by measuring the 2.27 min. ²⁸Al activities produced by the ²⁸Si (n, p) ²⁸Al reaction. Wing²⁰⁾ proposed two procedures for the simultaneous determination of oxygen and silicon in meteorites. In a procedure, the output signals from a NaI (TI) detector were fed into two single channel analysers, which were set to accept the 6~7 MeV gamma activities of 7.3 sec. ¹⁶N and the 1.78 MeV gamma activities of ²⁹Al, respectively, and the decays were

* 重松恒信, 藤野治, 本浄高治

followed. In the other procedure, the output was fed into a 200 channel analyser and a gamma-rays spectrum was analysed, without the decay following. He mentioned that the former procedure was more accurate than the latter, because various effects of the matrix elements were eliminated by ascertaining the half life. In the authors' experiment, therefore, the gamma-rays spectra were measured at a definite intervals of time, in order to obtain the decay curves.

Low density of the neutron flux is not desirable in the sensitivity of the analysis, but it has some advantages; very simple operation of the generator, comparatively easy shielding of the radiation, much safe handling of the irradiated samples, and almost complete elimination of the interfering nuclear reactions.

EXPERIMENTAL

Neutron Generator. Nearly monoenergetic neutrons with energy of approximate 14.3 MeV, were produced by the T-D reaction with a Picker-Dressen Neutron Generator, a very small sealed-off type generator. The equipment consists of two main units, a Neutron Generator Unit 2920 and a Control Unit 2921; the latter contains all the controls to operate the generator. The Neutron Generator Unit 2921 shapes cylindrically and consists of a stainless steel acceleration tube (198 mm long \times 80 mm in diameter) and an aluminium alloy tank tube (760 mm long \times 100 mm in diameter). Two tubes are tightly connected with a tube locking ring in such a manner that they have the same axis, as shown in Fig. 1. An ion source and a target (thin layer titanium evaporated on a copper backing and impregnated with 5 curies of tritium) are also included in the acceleration tube, which is evacuated to a pressure of about 10^{-3} Hg.

Deutrons which are released from a titanium dispenser by electrical heating

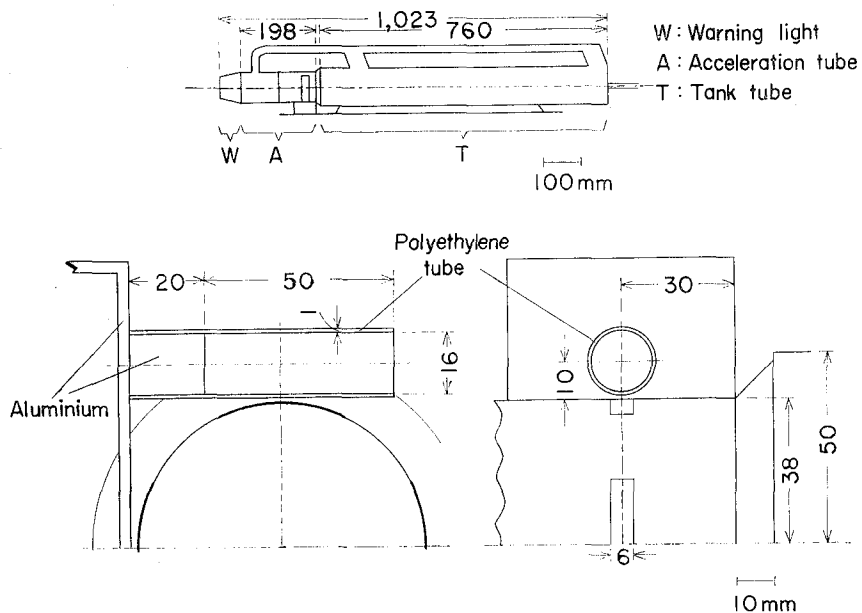

Fig. 1. Schematic diagram of the activation geometry.

and ionized in the ion source by the collisions with electrons, are accelerated by the high potential difference (132 KeV) and then bombard the tritium target. The high potential is supplied by a Van de Graff type electrostatic high voltage machine which operates under about 20 atm. of carbon dioxide in the tank tube.

The maximum output of about 10^8 neutrons per second in 4π solid angle can be attained by rising the belt current up to $12\mu A$. The neutron flux is not radial symmetry around the circumference of the acceleration tube, but there are four high flux areas, ca. 35 mm long along the circumference and 6 mm wide, which are marked on the surface of the tube.

The generator unit was shielded with 300 mm thick paraffin and 300 mm thick concrete, and the control unit was set up at a distance of about 4 m from the target. Thus the radiation did not exceed the weekly maximum permissible dose of 100 millirem, even when a operator worked during 10 hours in a week.

Sample handling. The sample transfer system such as a pneumatic tube was not laid out, but a long handled tongs was used to transfer the samples, because of the relatively low neutron flux.

Radioactivity Measurements. Gamma-rays spectra were obtained with a well-type NaI (Tl) scintillation counter coupled to a TMC Gammascoper, Model 101 (a 100 channel puls height analyser). Two kinds of crystals were used; one, 50.8 mm thick \times 45.5 mm in diameter, was used mainly for the measurements of ^{62}Cu activities induced by the $^{63}\text{Cu}(n, 2n)^{62}\text{Cu}$ reaction in a copper foil employed to estimate the neutron flux; and the other, 78.2 mm thick \times 78.2 mm in diameter, was used for the measurements of the radioactivity induced in silica standards and sediment samples. A endwindow-type GM counter was also used for estimating the neutron flux during the activation of the standards or the samples.

RESULTS

Measurements of the Neutron Flux. In preceding the experiments on the activation analysis of silicon, the neutron flux was measured at some positions. Neutron flux was estimated by activating standard (weighed) copper foil. The positrons emitted from the 9.8 min. ^{62}Cu nuclides were counted in a 2π proportional counter and the same sample foil was used to standardize the well-type NaI (Tl) (50.8 mm \times 45.5 mm in dia.) scintillation counter.

The following relation thus obtained was applied to estimate the neutron flux:

$$\phi = 45.34 \times \frac{A_0^S}{W}$$

where ϕ was the neutron flux ($n/\text{cm}^2 \cdot \text{sec.}$), A_0^S , counting rate (cpm) of the annihilation gamma peak extrapolated to the end of the irradiation, and W , weight of copper foil (g), respectively.

As schematically indicated in Fig. 2, the flux were measured at eight positions, and the values were represented in Table I. The position A is just on the center of a highest flux area: B is the middle point between two highest flux areas; C and D are 10 mm distant from A, towards and off the tank tube, respectively. These positions are in contact with surface of the acceleration tube. A', B', C' and D' are the same positions with A, B, C and D, respectively, but 10 mm outside of the surface.

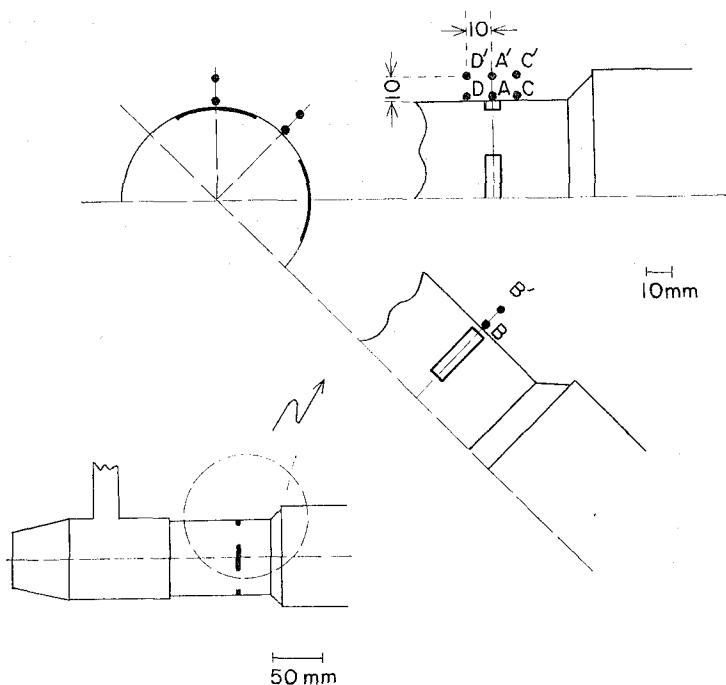

Fig. 2. Schematic diagram of the flux monitoring positions.

Table I.

position	neutron flux (n/cm ² ·sec)*
A	3.41×10 ⁵ , 3.28×10 ⁵
B	2.10×10 ⁵
C	0.96×10 ⁵ , 1.05×10 ⁵
D	0.51×10 ⁵
A'	1.95×10 ⁵ , 2.13×10 ⁵ , 2.33×10 ⁵ , 2.00×10 ⁵
B'	1.61×10 ⁵ , 1.51×10 ⁵
C'	0.84×10 ⁵ , 0.78×10 ⁵
D'	0.41×10 ⁵

* Belt current 10.2~10.4μA

Analysis of Silica in Marine Sediment Samples. Figure 1 shows a schematic diagrams of the activation geometry. Two highest flux areas can be simultaneously employed for the irradiation. Sample holders are made of cylindrical aluminium stick (20 mm long × 18 mm diameter) and thick polyethylene tubing (75 mm long × 18 mm in inside diameter). Each holder is set up at such a position that the axis of the cylindrical holder is just 10 mm distant outside of the vertical tangent line at the central point of the highest flux area.

A marine sediment core analysed was sampled from a station in the Japan

Sea (39°53'N, 133°06'E, depth 3,300 m). The core was 54.5 cm long and consists of eight layers, which were separated and numbered from 1 to 8 in the direction of the depth. Sample No. 1 belonged to a layer having the depth interval from 0 to 5 cm, below the sea bottom; No. 2, from 5 to 10 cm, No. 3, from 10 to 16 cm; No. 4 from 16 to 22.5 cm; No. 5 from 22.5 to 32.5 cm; No. 6 from 32.5 to 35.5 cm; No. 7 from 35.5 to 44.5 cm; and No. 8 from 44.5 to 54.5 cm, respectively.

Standard of silica was prepared by powdering pure quartz, washing with diluted hydrochloric acid and with water, and then drying at 110°C for a few hour.

The procedure for the activation analysis was designed as follows. After drying at 110°C, 1 g of fine powdered sample is weighed into a polyethylene capsule (70 mm long × 16 mm in inside diameter). When the neutron flux becomes constant, small concrete blocks placed above the sample holders are removed, the capsule containing the sample and a copper foil (to correct the neutron flux) are inserted into each of two holders at the same time, and the concrete blocks are placed back. This process must be carried out as quick as possible. At the end of 5.0 minutes of the irradiation, the generator is stopped, and the activated sample capsule is transferred to the NaI scintillation counter and the copper foil to the GM counter*.

Gamma-rays spectrum is obtained and the decay of the 1.78 MeV photo-peak is followed, while the activity of the copper foil is counted during the period from 1 to 6 minutes after the end of the irradiation. The counting rate of the ²⁸Al photo-peak is extrapolated to the end of the irradiation and normalized at the value in the flux of 2.00×10^5 n/cm².sec., by using the ⁶²Cu activities simultaneously irradiated*.

The change in the volume of the sample, in other word, the change in the depth of the sample in a polyethylene capsule gives considerable effect to average neutron flux in the sample, especially when very small volume of sample is irradiated. Therefore, in such a case, the sample powder was diluted with titanium oxide powder to make the depth about 40 mm: Titanium oxide did not show the induced activity, even after 10 minutes irradiation.

Typical gamma-rays spectra of a silica standard and a sediment sample (sample No. 5) are shown in Fig. 3. Both the spectra have the similar shape and give a evident photo-peak of 1.78 MeV gamma-rays. The decay curves of the photo-peak (1.55~2.05 MeV) are shown in Fig. 4: The half-life is in good agreement with the value of 2.27 min. ²⁸Al, produced by the ²⁸Si (n, p) ²⁸Al reaction. Figure 5 indicates the analytical curve for the determination of silica, which was obtained by activating a series of the standards containing 0.2, 0.4, 0.6, 0.8 and 1.0 g of silica, respectively.

Silica content in the samples were determined by using the analytical curve, and the results are summarized in Table II, with the values obtained colorimetri-

* As two scintillation counters could not be used in this research, the ⁶²Cu activities were counted with a GM counter. Under the conditions employed, the neutron flux was calculated by the equation,

$$\phi = 1.64 A^{GM}/W,$$

where A^{GM} was counts obtained during the period from 1 to 6 minutes after the end of the irradiation.

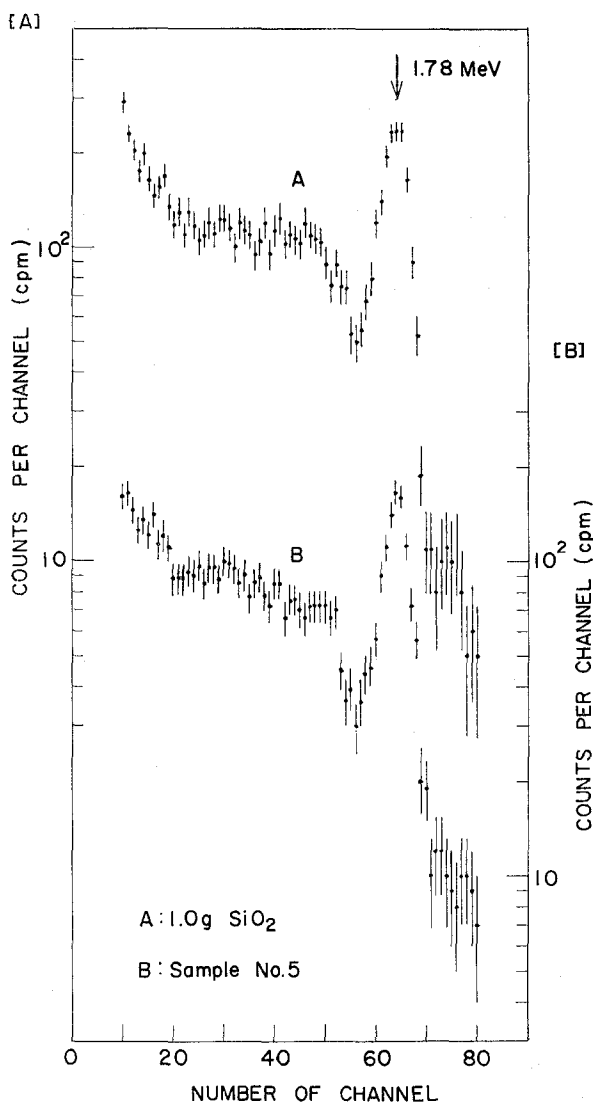

Fig. 3. Gamma-rays spectra of the irradiated silica standard and a marine sediment sample.

cally by the molybdenum yellow method*. Both results agree with each other with the error of about 5%.

From gamma-rays spectra and the decay curves, it can be expected that any interfering activities are not present in the irradiated samples. Actually, gamma-rays spectrum of a synthetic sample excluding silica did not show measurable activities above 1.5 MeV. The shielding effects of the matrix elements

* In a nickel crucible, 0.1 g of the sample is fused with 2 g of sodium hydroxide and 0.2 g of fusing mixture. The melt is leached with hot water and the solution is filtered into a 250 ml. volumetric flask. One milliliter of the solution is pipetted to a 50 ml volumetric flask, and after added 5 ml of 10% ammonium molybdate solution and diluted to the mark, the absorbance is obtained at 360 m μ against the reagent blank.

Determination of Silicon by Neutron Activation

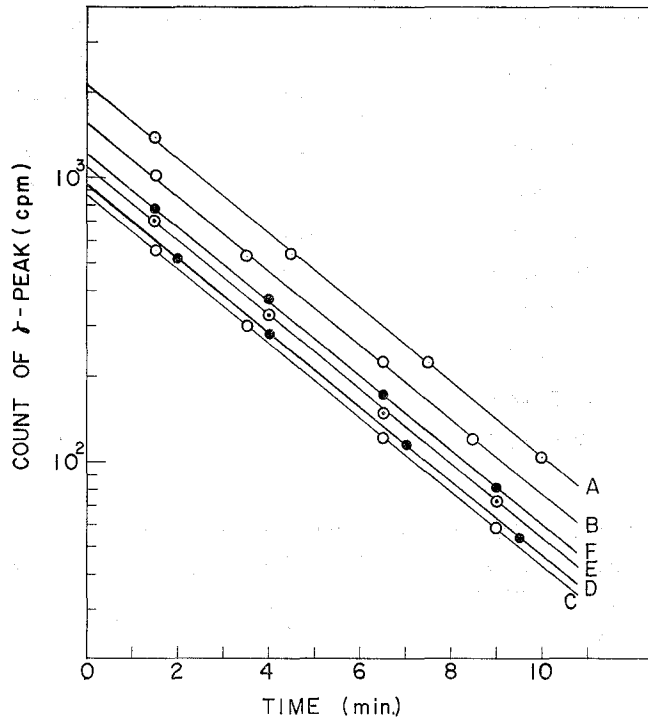

Fig. 4. Decay curves of the 1.78 MeV gamma-rays peak of aluminium-28 in the irradiated silica standards and samples.
 A : 1.0 g SiO₂. B : 0.8 g SiO₂. C : 0.6 g SiO₂.
 D : Sample No. 3. E : sample No. 5. F : Sample No. 7.

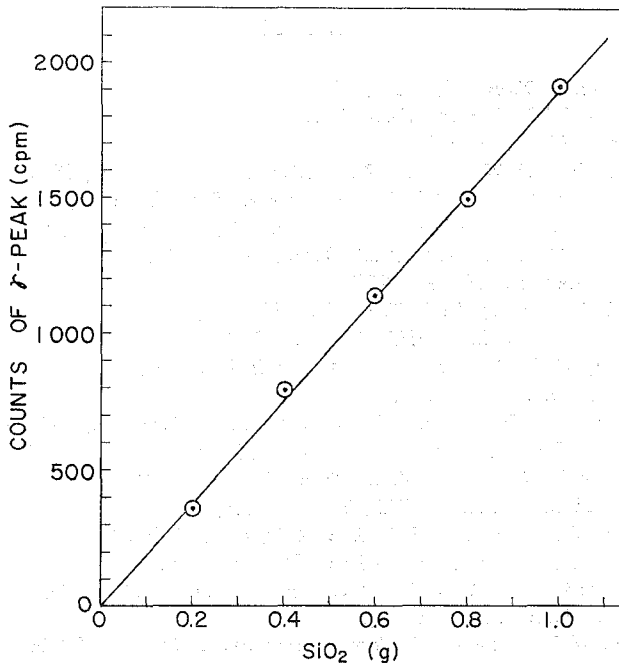

Fig. 5. Analytical curve for the determination of silica.

Table II.

Sampl No.	Depth (cm)	SiO ₂ Content (%)	
		this method	colorimetry
1	0 ~ 5	52.7	55.6
2	5 ~10	52.4	56.7
3	10 ~16	46.2	47.7
4	16 ~22.5	51.2	52.8
5	22.5~32.5	46.5	46.8
6	32.5~35.5	54.8	52.8
7	35.5~44.5	50.1	51.6
8	24.5~54.5	45.2	42.1

were examined by mixing the similar synthetic sample with standard silica. The result indicated the effect was negligible. The ²⁸Al activities are also induced from phosphorus by the ³¹P (n, α) ²⁸Al reaction, but fortunately, the amount of phosphorus in the samples was less than 0.2 %, and therefore the interference can be neglected.

ACKNOWLEDGMENT

The authors are greatly indebted to Mr. Katsumi Yamamoto of Maizuru Marine Observatory, for offering the marine sediment samples.

REFERENCES

- (1) S.E. Turner; *Anal. Chem.*, **28**, 1457 (1956).
- (2) R.F. Coleman and J.L. Perkin; *Analyst*, **84**, 233 (1959).
- (3) R.F. Coleman; *ibid.*, **86**, 39 (1961).
- (4) A.S. Gillespie, Jr. and W.W. Hill; *Nucleonics*, **18**, No. 11, 170 (1961).
- (5) Y. Kusaka, H. Tsuji and T. Adachi; *Bull. Chem. Soc., Japan*, **36**, 1259 (1963).
- (6) Y. Kusaka, H. Tsuji, I. Fujii, H. Muto and K. Miyoshi; *ibid.*, **38**, 616 (1965).
- (7) M.P. Menon and M.Y. Cuypers; *Anal. Chem.*, **37**, 1057 (1965).
- (8) R.E. Coleman; *Analyst.*, **87**, 590 (1962).
- (9) D.J. Veal and C.F. Cook; *Anal. Chem.*, **34**, 178 (1962).
- (10) E.L. Steel and W.W. Meinke; *ibid.*, **34**, 185 (1962).
- (11) R.A. Stallwood, W.E. Mott and D.T. Fanale; *ibid.*, **35**, 6 (1963).
- (12) W.F. Harris; *Talanta*, **11**, 1376 (1964).
- (13) R.W. Benjamin, K.R. Blake, and I.L. Morgan; *Anal. Chem.*, **38**, 947 (1966).
- (14) J.M. Van Wyk, M.Y. Cuypers, L.E. Fite and R.E. Wainerdi; *Analyst*, **91**, 316 (1966).
- (15) O.U. Anders and D.W. Briden; *Anal. Chem.*, **36**, 287 (1964).
- (16) O.U. Anders and D.W. Briden; *ibid.*, **37**, 530 (1965).
- (17) J.R. Vogt and W.D. Ehmann; *Radiochim. Acta*, **4**, 24 (1965).
- (18) J.T. Gilmore and D.E. Hull; *Anal. Chem.*, **34**, 187 (1962).
- (19) R.L. Caldwell and W.R. Mills, Jr.; *Nucl. Instr. Meth.*, **5**, 312 (1959).
- (20) J. Wing; *Anal. Chem.*, **36**, 559 (1964).
- (21) J.R. Vogt and W.D. Ehmann; *Geochim. cosmochim. Acta*, **29**, 373 (1965).