

Title	Tensile Creep Behavior of Monodisperse Poly- - methylstyrene (Special Issue on Polymer Chemistry, IV)
Author(s)	Odani, Hisashi; Kitamura, Shuji; Nemoto, Norio; Kurata, Michio
Citation	Bulletin of the Institute for Chemical Research, Kyoto University (1967), 45(2): 122-131
Issue Date	1967-07-20
URL	<a href="http://hdl.handle.net/2433/76195">http://hdl.handle.net/2433/76195</a>
Right	
Type	Departmental Bulletin Paper
Textversion	publisher

# Tensile Creep Behavior of Monodisperse Poly- $\alpha$ -methylstyrene

Hisashi ODANI, Shuji KITAMURA, Norio NEMOTO,  
and Michio KURATA\*

(Kurata Laboratory)

Received April 27, 1967

Tensile creep measurements were made on five monodisperse polymer samples of poly- $\alpha$ -methylstyrene. The range of molecular weights was from 105,000 to 1,740,000 and that of the temperatures was between 140 and 210°. The temperature dependence of the tensile creep compliance was described by the method of reduced variables. The shift factors were identical for all samples in the temperature region above the reference temperature 172°. The free volume parameters were derived from the WLF parameters: the fractional free volume was  $f_{172}=0.032$  at 172° (or  $f_g=0.028$  at the glass transition point) and the thermal expansion coefficient was  $\alpha_f=6.4 \times 10^{-4}$ . The steady-state compliance  $D_e$  and the tensile viscosity  $\eta_l$  were calculated by using the extrapolation method of Ninomiya. It is shown that the dependence of these quantities on molecular weight is different from that predicted by the Rouse-Bueche theory or by the semiempirical Ferry-Landel-Williams theory. The values of  $D_e$  decreased with increasing molecular weight, and became nearly independent of molecular weight in the range of sufficiently high molecular weights. The values of  $\eta_l$  varied with about 3 power of molecular weight for molecular weights lower than about 200,000. In the range of high molecular weights ( $\sim 10^6$ ) there was a large decrease in the dependence on molecular weight of  $\eta_l$ . The value of the average molecular weight between entanglements,  $M_e$ , was derived, using the theory of rubber elasticity, from plots of tensile creep compliance at a fixed time against temperature. The values of  $M_e$  evaluated decreased with increasing molecular weight up to about 200,000 and then leveled off a certain constant value.

## INTRODUCTION

Recently, Tobolsky *et al.*<sup>1)</sup> have studied the viscoelastic properties of five monodisperse polystyrene samples which ranged in molecular weight between 80,000 and 270,000. They have shown that the dependence on molecular weight of quantities, such as the tensile viscosity  $\eta_l$ , the steady-state shear compliance  $J_e$ , and the maximum relaxation time  $\tau_m$ , was quite different from that predicted by the Rouse-Bueche theory<sup>2,3)</sup> or by the semiempirical Ferry-Landel-Williams theory.<sup>4)</sup> Contrary to these experimental findings, Ninomiya and Ferry<sup>5)</sup> have reported that values of  $\eta$  (shear viscosity) and  $J_e$  of sharp fractions of polyvinyl acetate were near those predicted by the Ferry-Landel-Williams theory in the range of molecular weight from 5,500 to 780,000 as evaluated from creep measure-

\* 小谷 寿, 北村周治, 根本紀夫, 倉田道夫

ments. Thus, at present, it appears that further experimental study is needed for establishing the viscoelastic behavior of bulk polymers.

We here present some measurements of tensile creep of five monodisperse poly- $\alpha$ -methylstyrene samples. These were undertaken to provide more experimental data, especially those of molecular weight dependence of  $\eta_1$  and  $D_e$  (steady-state tensile compliance) to our knowledge on the viscoelastic properties of bulk polymers of which the molecular weight distribution is very sharp.

## EXPERIMENTAL

### Materials

The poly- $\alpha$ -methylstyrene studied was prepared by anionic polymerization *in vacuo* at  $-78^\circ$  with *n*-butyllithium as the initiator and tetrahydrofuran as the solvent. The apparatus and technique used for the preparation were similar to those described by Morton *et al.*<sup>6)</sup> and by Fujimoto *et al.*<sup>7)</sup> A possible tail of the molecular weight distribution in the lowest end was eliminated by fractionation at  $34.5^\circ$  using a large-scale elution column with benzene-ethyl alcohol mixtures. The number-average molecular weight,  $M_n$ , was determined by osmometry in toluene at  $37^\circ$  using a high-speed membrane osmometer (Mechrolab Model 502). The weight-average molecular weight,  $M_w$ , was evaluated from intrinsic viscosity using the empirical relation for the monodisperse polymer,<sup>8)</sup>  $[\eta] = 1.18 \times 10^{-4} M_w^{-0.70}$  (toluene,  $25^\circ$ ). Viscosity measurements were carried out using a dilution viscometer of the Ubbelohde type. The number-average and weight-average molecular weights of samples are given in Table I. The sedimentation boundary curve of each sample was also obtained by a Spinco-E ultracentrifuge at theta point (cyclohexane,  $39^\circ$ ), and the ratio  $M_w/M_n$  was evaluated therefrom. The results are also given in the fourth column of Table I.

Table I Monodisperse Poly- $\alpha$ -methylstyrene

Sample	$M_n^a$	$M_w^a$	$M_w/M_n$
MS-1	...	$1.74 \times 10^6$	1.00
MS-2	$1.87 \times 10^6$	$1.89 \times 10^6$	1.01
MS-3	$2.27 \times 10^6$	$2.29 \times 10^6$	1.01
MS-4	$1.02 \times 10^6$	$1.05 \times 10^6$	1.02
MS-6	$4.03 \times 10^6$	$3.86 \times 10^6$	1.01

<sup>a</sup> Accuracy in determination of  $M_n$  and  $M_w$  was about five percent.

For tensile creep measurements, thin films were obtained by slow evaporation of solvent from a 10% methylene chloride solution on a clean mercury surface. Final traces of the solvent were removed by prolonged drying in a vacuum oven at  $180^\circ$ . The weight of films was checked to insure complete volatilization of methylene chloride. The film thickness was measured by means of a micrometer with a precision of about  $\pm 2 \times 10^{-4}$  cm., and both the length and width were measured with a precision of about  $\pm 0.02$  cm. The films used for tensile creep measurements were about  $3 \times 10^{-2}$  cm. thick, 1 cm. wide, and 2 cm. long.

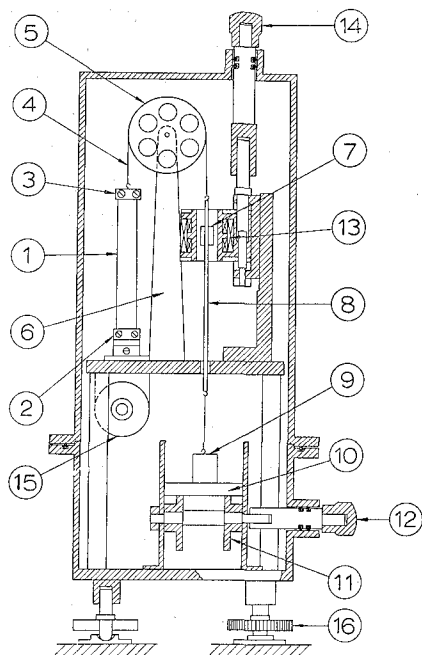

Fig. 1 Schematic diagram of the tensile creep apparatus.

(1) sample film; (2, 3) lower and upper clamps; (4) fine copper wire; (5) aluminium alloy pulley; (6) brass post; (7) iron core; (8) brass rod; (9) loading weight; (10) loading platform; (11) cam; (12) milled knob for lowering or raising the loading platform; (13) differential transformer; (14) milled knob for moving the differential transformer in the vertical direction; (15) second transformer; (16) levelling screw.

## Methods

The tensile creep measurements were made with a creep balance type apparatus. A schematic diagram of the apparatus is shown in Figure 1. The balance consists of a vertical brass post (6), near the top of which is pivoted an aluminium alloy pulley (5). The pulley hangs, with a fine copper wire (4), an upper clamp (3) on one side and an iron core (7), a thin brass rod (8), and a loading weight (9) on the other. A special care was undertaken in the design of the pulley and the pivot for smooth rotation and rigidity. With this balance, loads from 2 g. to 1,000 g. may be applied with a precision of about  $\pm 0.3$  g. In order to avoid being applied any load to the sample film before the start of tensile creep measurements, the weight of the upper clamp was exactly balanced with that of the iron core and the brass thin rod.

A sample film (1) of appropriate size and thickness is mounted between the upper and lower clamps. The lower clamp (2) is fixed to a base plate. The loading weight is applied to the sample film by lowering the loading platform (10). The loading platform can be lowered or raised from outside the apparatus housing by turning the milled knob (12) which is attached to the axis of cam (11). The base plate of the apparatus housing is supported by three levelling screws (16).

The change in length of the sample film is detected by a linear variable

differential transformer, and is amplified and recorded by means of a linear variable differential transformer recorder (Iwamoto Seisakusho Ltd., Kyoto). With these arrangements a change in length of  $5 \times 10^{-4}$  cm. could be measured with a precision of about  $\pm 2 \times 10^{-4}$  cm. By turning a milled knob (14) the differential transformer (13) is moved in the vertical direction from outside, and the null position on the recorder scale may be adjusted. The variation of the characteristics of the differential transformer with temperature is cancelled by the second transformer (15).

Heating is effected by means of six electric heaters arranged at different heights of the apparatus housing. Each heater has its own separate control. The atmosphere within the apparatus housing was stirred by an electric fan which is attached to the top plate of the apparatus housing. The apparatus was mounted in a large air thermostat whose temperature was maintained at about  $80^\circ$ . Due to these arrangements the temperature between  $100^\circ$  and about  $220^\circ$  may be kept constant at any point near the sample film with a precision of about  $\pm 0.1^\circ$ . The temperature was measured by means of a copper-constantan thermocouple placed in quite near to the center of the sample film. The temperature was also monitored using thermometers placed near to the upper and the lower clamps.

The sample films were mounted in the clamps while they were cold and the position of the clamp jaws was used as a reference of length. After mounting the sample film, the apparatus was heated to the desired temperature and allowed to remain unloaded for a period of about an hour. After this time the sample length was measured, and the null position on the recorder scale was adjusted. The apparatus housing is provided with glass windows on front and back so that the sample length may be measured by means of a travelling microscope. The load was then applied to the sample and the subsequent changes in sample length were followed by means of the recorder. With present instrumentation, it was not possible to obtain reliable readings in times shorter than 6 seconds after the initial loading. Measurements were performed from  $140$  to  $210^\circ$ , and the maximum tensile strain did not exceed 20%. Preliminary experiments have revealed that at temperatures higher than about  $240^\circ$  the thermal degradation of poly- $\alpha$ -methylstyrene took place, though in slight extent, during the period of tensile creep measurement. Accordingly, measurements were limited to in the temperature region below  $210^\circ$ .

## RESULTS AND DISCUSSION

The tensile creep compliance,  $D(t)$ , of sample MS-4 is plotted logarithmically against time,  $t$ , in Figure 2 at nine temperatures from  $144$  to  $201^\circ$ . Similar families of creep curves were obtained for other samples.

Figure 3 shows the master curves which were obtained by shifting the experimental curves according to the time temperature superposition principle. Here the subscript  $p$  denotes that the tensile creep compliance has been multiplied by  $T\rho/T_0\rho_0$ , where  $\rho$  and  $\rho_0$  are the densities at temperatures  $T$  and  $T_0$ , respectively, and  $T_0$  is a reference temperature. The reference temperature was chosen as  $172^\circ$  for all samples. The many individual points for all different temperatures,

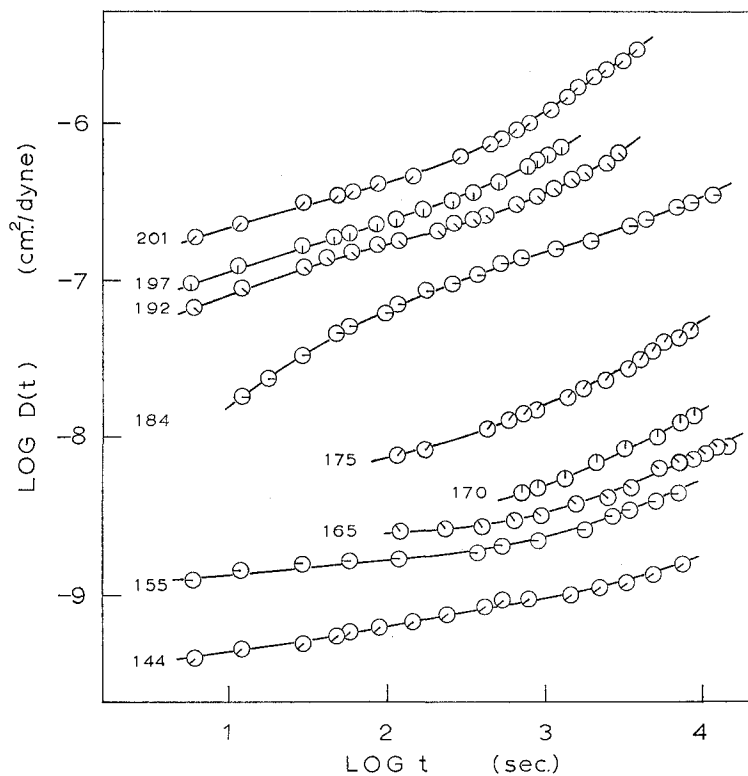

Fig. 2 Tensile creep compliance of sample MS-4, plotted logarithmically against time at nine temperatures as indicated.

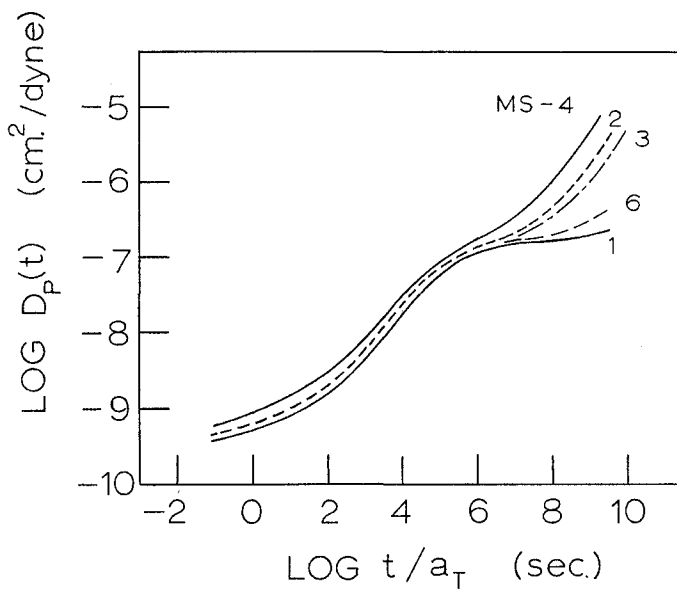

Fig. 3 Tensile creep master curves for five poly- $\alpha$ -methylstyrene samples as indicated at 172°.

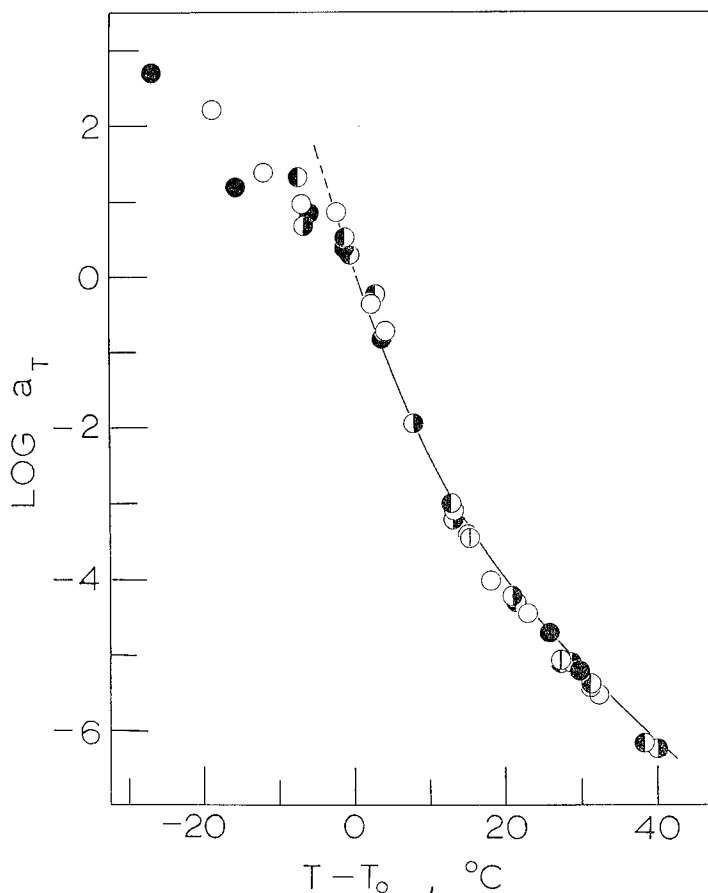

Fig. 4.  $\log a_T$  plotted against  $T-T_0$  for five poly- $\alpha$ -methylstyrene samples.

○, MS-1; ◐, MS-2; ◑, MS-3;  
●, MS-4; ⊙, MS-6.

not shown, lay mostly within 2% of the master curves.

The shift factor,  $a_T$ , used for the reduction is plotted semilogarithmically against  $T-T_0$  in Figure 4. It is seen that values for all samples coincide with one another at temperatures above the reference temperature. In this temperature region the shift factors for all samples followed the WLF equation<sup>9</sup>

$$\log a_T = -\frac{C_1(T-T_0)}{(C_2+T-T_0)} \quad (1)$$

with  $T_0=172^\circ$ ,  $C_1=13.7$ , and  $C_2=49.3$ . The solid curve in Figure 4 corresponds to this equation. From these WLF parameters we obtain  $f_{172}=0.032$  for a fractional free volume at  $172^\circ$  and  $\alpha_f=6.4 \times 10^{-4}$  for a thermal expansion coefficient of the free volume. The corresponding free volume at the glass transition temperature, if  $165^\circ$  is chosen,\* is 0.028.

The steady-state compliance,  $D_e$ , and the tensile viscosity,  $\eta_t$ , were calculated

\* In preliminary volumetric measurements, all the present samples undergo the glass transitions in the vicinity of  $165^\circ$ .

by using the extrapolation method of Ninomiya.<sup>10)</sup> That is, a plot of  $mD(t)/t$  versus  $1/t$  yields a relatively linear extrapolation to the intercept, and this intercept gives the value of  $1/\eta_i$ , where  $m$  denotes  $d \log D(t)/d \log t$ . Alternatively, the reciprocal of  $\eta_i$  may be evaluated from the intercept of a plot of  $D(t)/t$  versus  $1/t$ , and the value of  $D_e$  from the initial tangent of this plot. Figure 5 shows the plots of  $D(t)/t$  and  $mD(t)/t$  versus  $1/t$  for sample MS-2 at 200°. It is seen from the figure that the plot of  $mD(t)/t$  versus  $1/t$  can be approximated by a straight line in fairly a wide region of time. This is also the case in all other samples. The values of  $D_e$  and  $\eta_i$  obtained at 200° by this method are given in Table II.

In the case of a high molecular weight sample such as MS-1 and -6, the determination of  $D_e$  and  $\eta_i$  may be subjected to some uncertainty, because the extrapolation to time infinity is made from the region where the values of  $m$  are about 0.1 to 0.3. In such a region of a relatively small  $m$ , it seems doubtful whether the true steady-state flow is reached or not. However, as seen in Figure 5, the plots of  $mD(t)/t$  versus  $1/t$  for the sample of relatively lower molecular weight are practically linear over the range of  $0.2 < m < 0.9$ , and are nearly parallel to the abscissa. This enables us to estimate the intercept in the  $mD(t)/t$  versus  $1/t$  plot with a reasonable accuracy. Thus, even when the molecular weight of sample is relatively high, it may be anticipated that the extrapolation method would lead to a reliable estimate of  $D_e$  and of  $\eta_i$ , though not very accurate.

In Figure 6 the values of  $D_e$  calculated at 200° are plotted logarithmically

Table II Steady-State Compliances and Tensile Viscosities of Five Monodisperse Poly- $\alpha$ -methylstyrenes at 200°

Sample	$D_e$ cm. <sup>2</sup> /dyne	$\eta_i$ poises
MS-1	$1.65 \times 10^{-7}$	$1.54 \times 10^{11}$
MS-2	$4.20 \times 10^{-7}$	$7.05 \times 10^9$
MS-3	$2.64 \times 10^{-7}$	$1.43 \times 10^{10}$
MS-4	$8.69 \times 10^{-7}$	$1.95 \times 10^9$
MS-6	$2.27 \times 10^{-7}$	$4.17 \times 10^{10}$

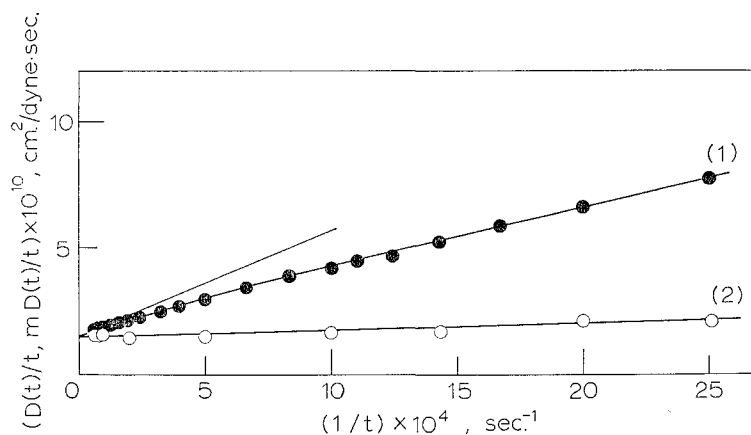

Fig. 5  $D(t)/t$ , (1), or  $mD(t)/t$ , (2), of sample MS-2 plotted against  $1/t$  at 200°.



Tensile Creep Behavior of Monodisperse Poly- $\alpha$ -methylstyrene

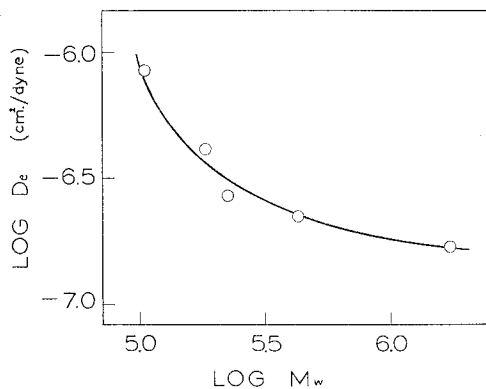

Fig. 6  $D_e$  at 200° plotted logarithmically against  $M_w$  for five poly- $\alpha$ -methylstyrene samples.

against  $M_w$ . It can be seen that the values of  $D_e$  decrease with increase of molecular weight and are nearly independent of molecular weight in the range of higher molecular weights. This is in contrast to the prediction of the Rouse-Bueche theory<sup>2,3)</sup> and also of the Ferry-Landel-Williams theory<sup>4)</sup>: the both predict that the steady-state compliance should be proportional to molecular weight. At present, the molecular mechanism underlying this feature is not known to us, but it is plausible that the feature would arise from the phenomenon of entanglement coupling. In this connection, it may be noted that Tobolsky et al.<sup>1)</sup> have obtained the steady-state shear compliance independent of molecular weight in the case of monodisperse polystyrene. In order to establish the behavior of steady-

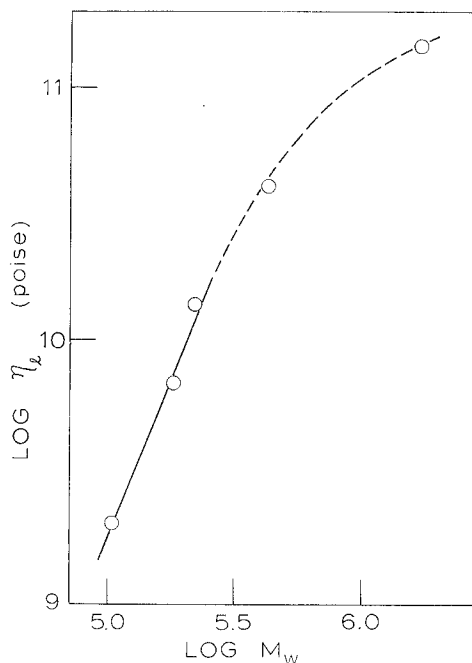

Fig. 7  $\eta_s$  at 200° plotted logarithmically against  $M_w$  for five poly- $\alpha$ -methylstyrene samples.

state compliance more firmly, similar study to the present is now in progress for monodisperse poly-*cis*-1,4-isoprene in our laboratory.

The values of  $\eta_i$  at 200° are plotted logarithmically against  $M_w$  in Figure 7. It is seen that the plot is a straight line for molecular weights smaller than about 200,000. The slope of this straight line is about 3. An interesting and rather surprising consequence is that the plot does not support a straight line for molecular weights greater than about 200,000 but a curve concave to the log  $M_w$  axis. The Rouse-Bueche theory predicts that the viscosity should be proportional to molecular weight, and the Ferry-Landel-Williams theory predicts  $\eta_i$  varies as  $M_w^{3.4}$ . As described before, for higher molecular weight samples, MS-1 and -6, the calculated values of viscosity may be somewhat sceptic. In addition, at temperatures higher than about 200°, it is still not sure that our poly- $\alpha$ -methylstyrene samples were absolutely safe from thermal degradation during the course of the tensile creep measurements.\* Therefore, at the moment, we reserve to conclude that for monodisperse poly- $\alpha$ -methylstyrene the values of  $\eta_i$  vary as smaller power of molecular weight than about 3 in the very high molecular weight range ( $\sim 10^6$ ). More extensive work would be necessary not only for this polymer but also for other monodisperse polymers, such as polyisoprene, before reaching a final conclusion.

Recently Tobolsky and Takahashi<sup>11)</sup> have estimated the value of the average molecular weight between entanglements,  $M_e$ , from shear modulus measurements at a fixed time as a function of temperature. They calculated  $M_e$  from the characteristic parameter  $E_2$  by using the theory of rubber elasticity. Here  $E_2$  is the value of 3 G (10), the rigidity modulus at 10 sec., multiplied by three, which is selected at the point in the rubbery plateau region where the slope of log [3 G (10)] versus temperature is a minimum. In order to estimate the value of  $M_e$  for our monodisperse poly- $\alpha$ -methylstyrenes, we may apply the quite similar procedure to the plots of the 1,000 sec. tensile creep compliance, D (1,000), against temperature. A characteristic parameter  $D_2$  may then be determined as the value of D (1,000) at the inflection in the plateau region of log D (1,000) versus temperature plots. We here chose 1,000 sec. as a fixed time. From the value of  $D_2$  thus obtained, the average molecular weight between entanglements is calculated from the equation

$$M_e = 3d R T_1 D_2. \quad (2)$$

Here  $d$  is the density,  $R$  is the gas constant, and  $T_1$  is the absolute temperature at which  $D_2$  is determined.

Figure 8 gives plots of  $M_e$  versus log  $M_w$ . The shape of the plots closely resembles that of logarithmic plots of  $D_e$  versus  $M_w$  shown in Figure 6. The values of  $M_e$  decrease with increase of  $M_w$  up to about 200,000 and then level off a certain constant value. Since at the lowest molecular weight of the sample is comparable to that between entanglements, the feature may tentatively be interpreted as being due to contribution from free chain ends. For the latter feature, it appears that the formation of entanglement network would be respon-

\* A study of thermal degradation of monodisperse poly- $\alpha$ -methylstyrene in the temperature region near 200° is now in progress in our laboratory.

## Tensile Creep Behavior of Monodisperse Poly- $\alpha$ -methylstyrene

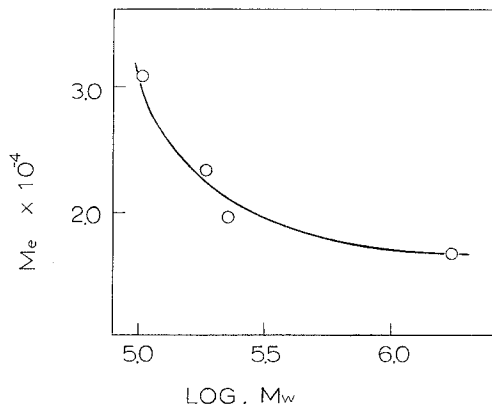

Fig. 8  $M_e$  plotted against  $\log M_w$  for four poly- $\alpha$ -methylstyrene samples.

sible. However, at present, the data obtained are so limited that more experimental material is needed before attempting any theoretical interpretation of the observed facts.

### ACKNOWLEDGEMENTS

The authors wish to thank Professor Mikio Tamura of this University for his encouragement and his continued interest in the course of this study. Sincere thanks are also tendered to late Dr. Masaaki Fukatsu of this Laboratory for many helpful discussions. We are much indebted to Mr. Mitsuo Abe of Japan Synthetic Rubber Co., Ltd., for the measurements of the number average molecular weights, and to Mr. Nobu Kitamura of this Laboratory for his help in the viscosity measurements.

### REFERENCES

- (1) A. V. Tobolsky, J. J. Aklonis, and G. A. Kovali, *J. Chem. Phys.*, **42**, 723 (1965).
- (2) P. E. Rouse, *J. Chem. Phys.*, **21**, 1272 (1953).
- (3) F. Bueche, *J. Chem. Phys.*, **22**, 603 (1954).
- (4) J. D. Ferry, R. L. Landel, and M. L. Williams, *J. Appl. Phys.*, **26**, 359 (1955).
- (5) K. Ninomiya and J. D. Ferry, *J. Phys. Chem.*, **67**, 2292 (1963).
- (6) M. Morton, A. A. Rembaum, and J. L. Hall, *J. Polymer Sci.*, **A1**, 461 (1963).
- (7) T. Fujimoto, N. Ozaki, and M. Nagasawa, *J. Polymer Sci.*, **A3**, 2259 (1965).
- (8) T. Fujimoto and M. Nagasawa, unpublished results.
- (9) M. L. Williams, R. F. Landel, and J. D. Ferry, *J. Am. Chem. Soc.*, **77**, 3701 (1955).
- (10) K. Ninomiya, *J. Phys. Chem.*, **67**, 1152 (1963).
- (11) A. V. Tobolsky and M. Takahashi, *J. Appl. Polymer Sci.*, **7**, 1341 (1963).