

Title	Apparatus for Measurement of Dipole Moments by Heterodyne Beat Method
Author(s)	Koizumi, Naokazu; Tsuji, Fukuju; Okamoto, Hiroyoshi
Citation	Bulletin of the Institute for Chemical Research, Kyoto University (1966), 43(4-5): 388-391
Issue Date	1966-02-28
URL	http://hdl.handle.net/2433/76079
Right	
Type	Departmental Bulletin Paper
Textversion	publisher

Apparatus for Measurement of Dipole Moments by Heterodyne Beat Method

Naokazu KOIZUMI*, Fukuju TSUJI* and Hiroyoshi OKAMOTO**

* (Koizumi Laboratory)

** (Kurata Laboratory)

Received September 30, 1965

An apparatus of the heterodyne beat type for measurement of the dipole moment is described, which consists of a 1 Mc crystal-controlled oscillator, a variable oscillator of the Franklin type, and a mixer and beat indicator. The Franklin oscillator has excellent stability, the frequency variation being within 1 cps for about one hour. Since the signals from the fixed and variable oscillators are pure sine, no spurious beat appears on the beat indicator. The dipole moments measured on nitrobenzene and chlorbenzene in benzene solutions give 3.99 D and 1.59 D respectively, being very consistent with the literature value.

During studies on the conformation of some polar polymers in solutions it became necessary to measure the dipole moment. Although there are several methods for measurement of the dipole moment, an apparatus of the heterodyne beat type was constructed in view of the accuracy¹⁾.

The apparatus consists of three units, a fixed frequency oscillator, a variable frequency oscillator, and a mixer and beat indicator. The fixed oscillator is a crystal-controlled oscillator using a 1 Mc quartz crystal. The circuit diagram is shown in Fig. 1. The output signal is taken from the grid of the 6C4 oscillator tube and coupled to a buffer amplifier. Thus an almost pure sine wave was

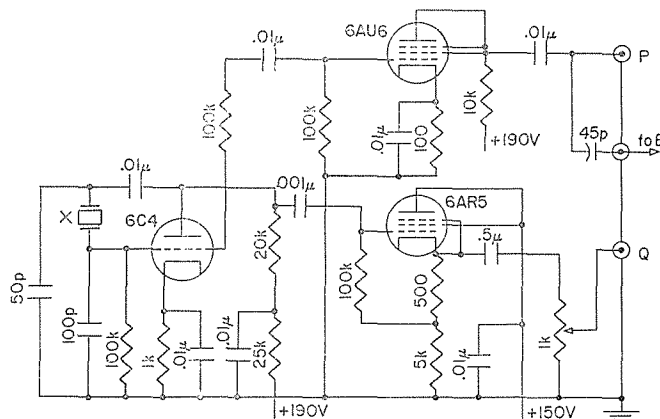

Fig. 1. 1 Mc crystal-controlled oscillator.

* 小泉 直一, 辻 福寿

** 岡本 宏義

Apparatus for Measurement of Dipole Moments by Heterodyne Beat Method

obtained as shown in Fig. 4 (a). The output signal of the amplifier is fed through a capacitor to the grid No. 3 of a 6BE6 converter tube. The input rf voltage at the grid is about 4.5V. The more or less distorted signal at the plate of the oscillator tube (Fig. 4 (b)) is coupled to the cathode follower stage, a 6AR5 tube, and fed to the output jack 'Q' which is useful for comparison of the harmonic frequencies of the crystal oscillator with the standard frequency from JJY.

As a variable frequency oscillator the Franklin type is employed in view of high stability and simple construction, as shown in Fig. 2²⁾. The tuning circuit

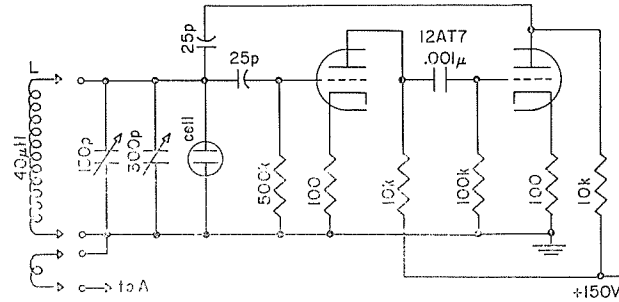

Fig. 2. Franklin oscillator.

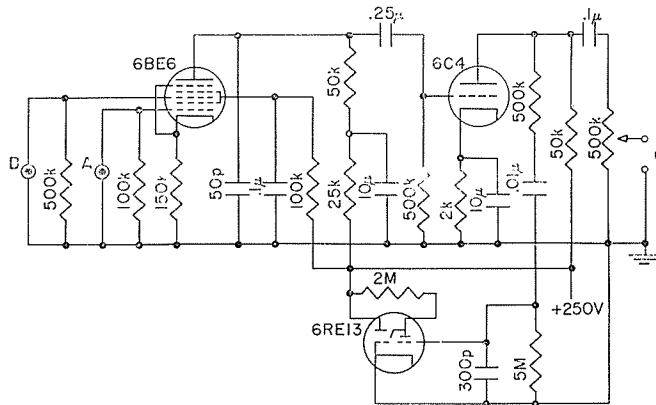
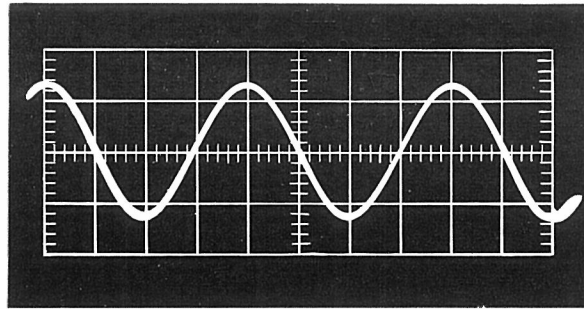

Fig. 3. Mixer and beat indicator.

is composed of a 300 pF precision variable capacitor with the full scale of 50,000 divisions, a 150 pF coarse variable capacitor, a dielectric cell capacitor, and an inductance coil of $40 \mu\text{H}$. The capacitance of the empty cell made up of concentric platinum cylinders is about 30 pF. The oscillator works for any medium having a cell conductance smaller than $0.1 \text{ m}\Omega$.

The output signal that has a high purity (Fig. 4 (c)) was drawn using a coupling coil and fed into the grid No. 1 of the converter tube. The oscillator has an excellent stability. When it runs in a thermostatic air box, the variation of frequency can be kept within ± 1 cps for about a hour.



(a)

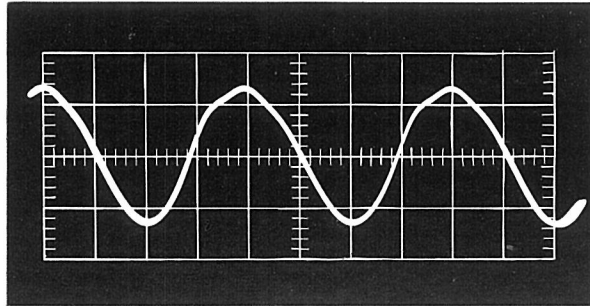

(b)

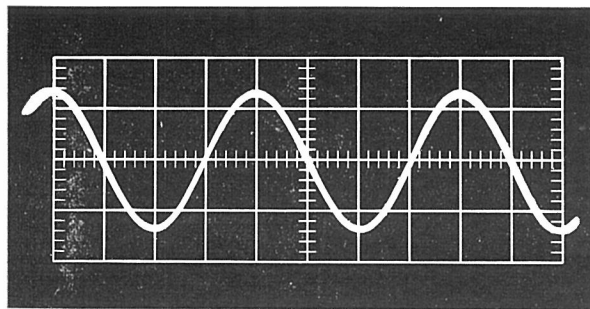

(c)

Fig. 4. Cathode-ray oscillographic patterns of signals : (a) and (b) are wave forms at the output jack 'P' and 'Q', respectively, of the crystal oscillator and (c) the output signal of the Franklin oscillator.

The mixer and beat indicator circuit is essentially the same as that reported by Jen-Yuan Chien³⁾. A conventional 6BE6 penta-grid converter tube is used as the frequency mixer. The beat note produced is displayed on the screen of a 6RE13 electron-ray tube which has a rectangle-shaped pattern instead of a sector shape in an ordinary electron-ray indicator tube. Since the output signals from the crystal and variable oscillators are almost pure sine waves, no spurious beat due to the harmonics is observed. The beat note is also amplified by a 6C4 triode tube and fed to the output terminals for use of an earphone and for cathode-ray oscilloscope measurements. The latter provides most accurate determination of the beat frequency using the Lissajous figure technique when a stable audio-frequency signal like a tuning fork oscillator is

Apparatus for Measurement of Dipole Moments by Heterodyne Beat Method

available. The overall precision in measurements of the cell capacitance is better than one part in 5000.

To check the operation of the apparatus the dielectric constants of nitrobenzen and chlorbenzene in benzene solutions were measured with different concentrations at 20°C. Typical results are shown in Fig. 5. The cell capacitor

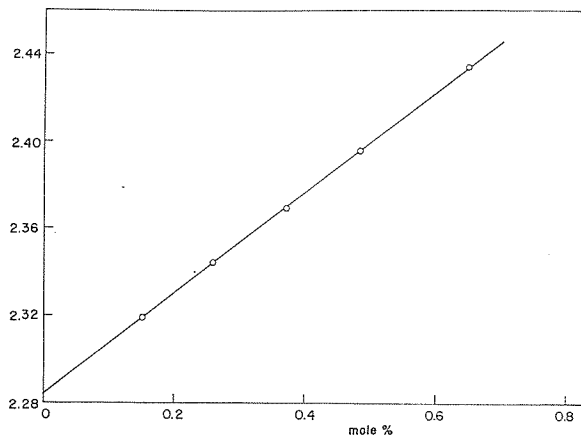

Fig. 5. Plots of dielectric constants ϵ of benzene solutions of nitrobenzene versus molar concentration at 20°C.

was calibrated with the standard liquids⁽¹⁾. The dipole moment obtained by the Halverstadt-Kumler method⁽⁵⁾ was 3.99D and 1.59D for nitrobenzene and chlorbenzene respectively, being in satisfactory agreement with the literature value⁽⁶⁾.

REFERENCES

- (1) C. P. Smyth, "Physical Methods of Organic Chemistry", Part III, Interscience Publishers, Inc., New York (1960), Chap. XXXIX.
- (2) R. J. W. Le Fèvre, I. G. Ross, and B. M. Smythe, *J. Chem. Soc.*, (1950) 276.
- (3) Jen-Yuan Chien, *J. Chem. Educ.*, 24, 494 (1947).
- (4) A. A. Maryott and E. R. Smith, NBS Circular 514, National Bureau of Standards, Washington, D. C. (1951).
- (5) I. F. Halverstadt and W. D. Kumler, *J. Am. Chem. Soc.*, 64, 2988 (1942).
- (6) L. G. Wesson, "Tables of Electric Dipole Moments", Technology Press of M. I. T., Cambridge, Mass., (1948).