

Title	Thermoluminescence from Gamma Irradiated Amino Acids (Special Issue on Physical, Chemical and Biological Effects of Gamma Radiation, IV)
Author(s)	Tahira, Sadamu; Shiomi, Naoko; Higashimura, Takenobu
Citation	Bulletin of the Institute for Chemical Research, Kyoto University (1963), 41(1): 48-54
Issue Date	1963-03-30
URL	http://hdl.handle.net/2433/75945
Right	
Type	Departmental Bulletin Paper
Textversion	publisher

Thermoluminescence from Gamma Irradiated Amino Acids

Sadamu TAHIRA, Naoko SHIOMI and Takenobu HIGASHIMURA*

(Department of Nuclear Science, Faculty of Science, Kyoto University)

Received December 15, 1962

Radiation induced thermoluminescence has been studied for five amino acids. The crystalline samples which are pressed to thin disks were irradiated at liquid nitrogen temperature and subsequently warmed to room temperature. Irradiation was carried out by a Co^{60} γ -rays and electron beams from a Van de Graaff accelerator. From glow curves, three conclusions are drawn. (1) Glow curves for phenylalanine, tryptophan, which contain ring structures, have predominant peaks in temperature range 110°K to 120°K with maximum intensity 12 μA . (2) Cystine has such a characteristics but it shows little dose dependency from 10^3 up to 10^7 r. (3) For amino acids except cystine, saturation occurs at about $10^5 \sim 10^6$ r.

INTRODUCTION

As for the radiation damages of macromolecules and organic crystals, only the final states, that is chemical and biological changes, have been studied, and the process by which the substances reach the final changes following the absorption of radiation energy has been inferred only through the observation of the chemical and biological changes. But, the techniques such as electron spin resonance began to solve the problem of the intermediate paths by direct measurements. Electron spin resonance can detect the free radicals produced by gamma-irradiation at liquid nitrogen temperature, and in many cases the absorbed energy is stored presumably at these free radicals as well as at lattice imperfections, and impurity atoms.

In general such states of energy storage are metastable and temperature-sensitive. They are stable at low temperature, but become unstable with temperature.

The substances which are irradiated at liquid nitrogen temperature emit light by the subsequent heating. In this so-called thermoluminescence the energy which are stored in the metastable species are transferred some distance and converted to the light quantum. From these considerations, thermoluminescence is another powerful method to investigate the intermediate process, that is 1) transfer of the absorbed energy, 2) localization of the energy at the particular site of molecule, and 3) storage of energy.

Amino acids are the constituent materials of protein and its radiation damage is a fundamental problem to be solved in the radiation biology. Augenstine and his collaborators showed the following results observing the γ -induced thermoluminescence of amino acids¹⁾.

* 田平 定, 塩見 直子, 東村 武信

Thermoluminescence from Gamma Irradiated Amino Acids

- A) The number of glow peaks is less than three.
- B) The peak at 165°K appears in all amino acids.
- C) Amino acids with ring structure show a intense peak at 100°K~140°K.

We have also investigated the thermoluminescence of γ -irradiated amino acids, but our main purpose was to see the dose dependency of the glow intensity.

EXPERIMENTAL

Crystalline amino acids were obtained mainly from Nakarai Chemicals. These materials were used without further preparation or purification. A portion of the powdered preparations, 250 mg, was pressed to a disk, 2 cm in diameter. The samples were held at liquid nitrogen temperature while being irradiated with Co^{60} γ -rays, and were heated at a linear rate of 12°K/min from 77°K to about 270°K and the emitted light was measured with a photomultiplier (EMI 9536 B) and a D.C. amplifier. Fig. 1 shows the experimental apparatus. The chromelalumel thermocouple was used to measure the temperature.

The samples were irradiated in the 2000 C Co^{60} γ -rays irradiation facility of the Institute for Chemical Research of Kyoto University. Dose rate was 1.4×10^5 r/h. Irradiation and subsequent heating were made in the atmosphere. In the case of irradiation for the dose above 10^7 r, samples were irradiated by 1.5 Mev electron beam from a Van de Graaff accelerator at Osaka Laboratory of the Japanese Association for Radiation Research on Polymers were used.

Reproducibility of the glow curve was distorted by the several factors, that is, suppliers of the samples, interval between irradiation and warm up, heating rate, the shape of the samples. Data were reproduced better in high intensity group than in low intensity group.

RESULTS AND DISCUSSIONS

The main data are presented in Table 1. Main glow curves are shown in

Table 1.

No. 1

Amino acid	Dose (r)	Temp. (°K)	Intensity (μA)
Phenylalanine	10^4	117	0.15
		131	0.05
	10^5	123	2.0
		3.6×10^5	113
	136		1.4
	133		12.0
	10^7	128	1.3
Tryptophan	10^4	118	0.55
		112	3.4
	3.6×10^5	102	3.2
		144	2.4
		116	8.0
	10^6	116	8.0
	10^7	120	7.0

No. 2

Amino acid	Dose (r)	Temp. (°K)	Intensity (μ A)	
Methionine	10 ⁴	123	0.05	
	10 ⁵	113	0.23	
	10 ⁶	117	0.45	
		128	0.13	
		211	0.038	
	Lysine	10 ⁷	101	0.015
			118	0.19
117			0.0024	
3.6×10 ⁶		185	0.0015	
		112	0.003	
		195	0.005	
		221	0.002	
	10 ⁶	129	0.008	
	186	0.006		
	231	0.003		

No. 3

Amino acid	Dose (r)	Temp. (°K)	Intensity (μ A)	
Lysine	10 ⁷	105	0.0067	
		190	0.013	
		223	0.012	
Cystine	10 ⁵	114	0.013	
	3.6×10 ⁶	109	0.0059	
		10 ⁶	127	0.012
		10 ⁷	108	0.063

Figs. 2~8. There is some inconsistencies between Augenstine's results and ours. For phenylalanine and tryptophan, there is one prominent peaks at 110°K~120°K, but this peak is divided to two peaks at 3.6×10⁶ r. Methionine and lysine have two or three peaks, and cystine has one peaks at 110°K, but its intensity is weaker compared to the amino acids with ring structure. Observations and conclusions are listed in the following.

(1) As mentioned by Augenstine¹⁾, from the peak intensity of glows, we can divide five samples to two groups. Those for phenylalanine, tryptophan, which contain ring structure, have main peaks in temperature range 110°K to 120°K with a maximum intensity of 12 μ A. For another group, which contain lysine, methionine, cystine, maximum intensity is the order of 10⁻¹~10⁻³ μ A. The intense glow of ring structure amino acids presumably corresponds to the high quantum efficiency of the aromatic hydrocarbons in fluorescence or scintillation.

(2) Dose dependency for five amino acids is presented in Fig. 9. From these dose dependency, we can also divide the samples to two groups. For the samples except cystine, saturation occurs at about 10⁵~10⁶ r, but for cystine

Thermoluminescence from Gamma Irradiated Amino Acids

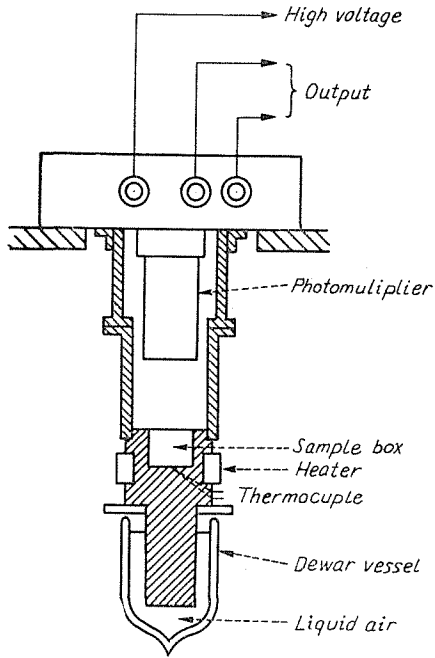

Fig. 1. Experimental apparatus.

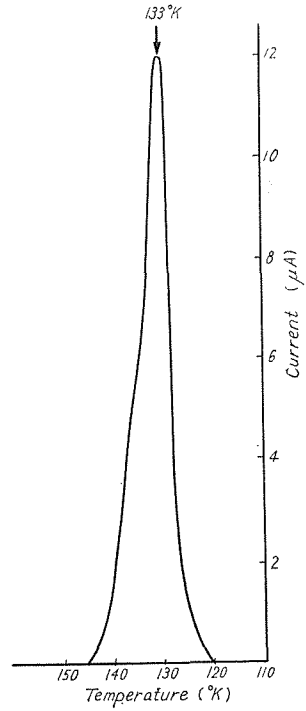

Fig. 2. Phenylalanine, 1×10^6 r.

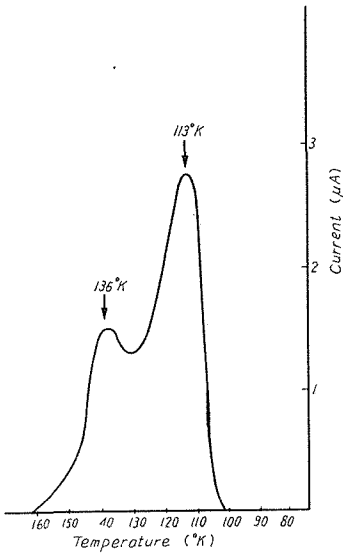

Fig. 3. Phynylalamine, 6×10^5 r.

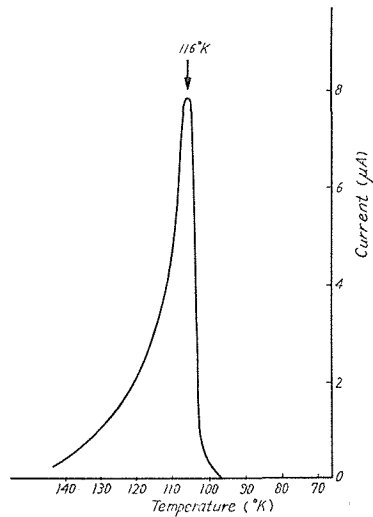

Fig. 4. Tryptophan, 10^6 r.

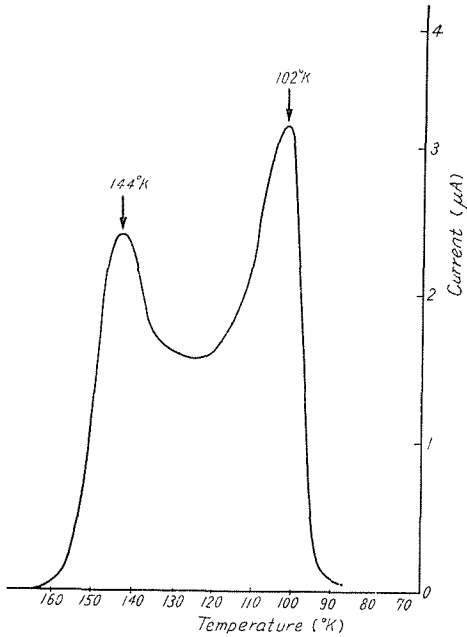

Fig. 5. Tryptophan, 3.6×10^5 r.

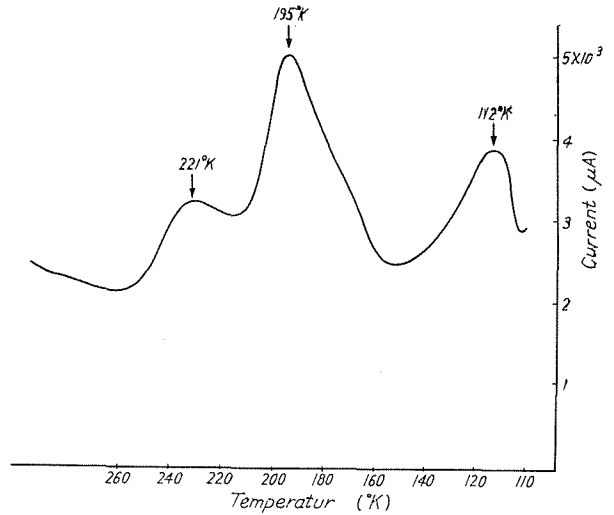

Fig. 6. Lysine, 3.6×10^5 r.

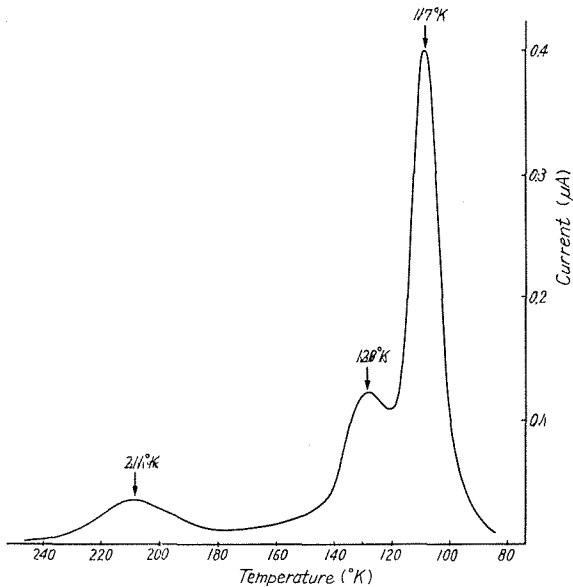

Fig. 7. Methionine, 10^6 r.

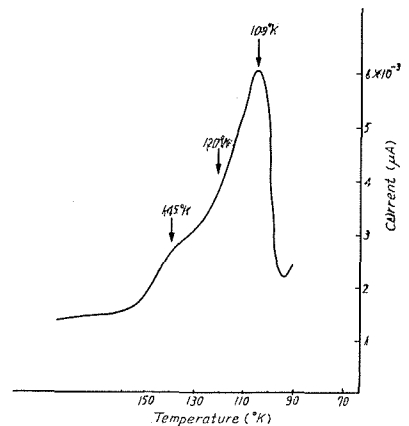

Fig. 8. Cystine, 3.6×10^5 r.

which contains disulphide bonds, prominent dose dependency was not observed within the dose used in this experiment.

The peculiarity of cystine in dose dependency seems to be related to the importance of the disulphide bonds in the inactivation of cystine. Consequently, we can classify five samples to three groups according to the chemical structures.

Thermoluminescence from Gamma Irradiated Amino Acids

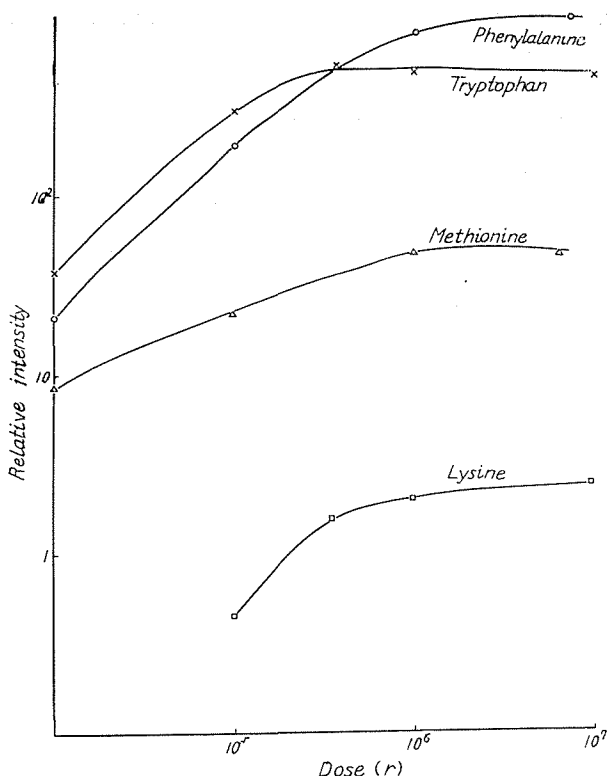

Fig. 9. Dose dependence (amino acids).

This is consistent with the fact²⁾ that the chemical structure is the important factor in glow curves rather than the crystalline structure. For the result about the dose dependency we can apply the one hit theory in radiation biology and make some order estimation. This theory may be interpreted by the target volume which can be destroyed by one ionization in it. The dose which gives in average one ionization per this target can be calculated from the curve of dose dependency as "37% dose". So, we can calculate the target volume from the dose dependency. In our case, adopting 10⁵ r as the 37% dose, the diameter of the target volume is 300 Å. This order of target volume suggests the existence of some lattice imperfections.

We can not yet derive the decisive conclusions from the above experiment. Together with thermoluminescence, the measurement of conductivity glow are under planning, by which more information seems to be obtained on the trapping states, the carriers of energy etc. Further, it seems necessary to measure the absorption spectra of the irradiated samples at liquid nitrogen temperature, for there is a fact that the color of the samples by irradiation disappears after the heating.

ACKNOWLEDGEMENT

The authors are greatly indebted to Mr. R. Katano at the Institute for

Sadamu TAHIRA, Naoko SHIOMI and Takenobu HIGASHIMURA

Chemical Research of Kyoto University and Mr. Y. Nakai and Osaka Laboratories of the Japanese Association for Radiation Research on Polymers, for their cooperation in irradiation procedures.

This study is supported by the research grant of the Ministry of Education.

REFERENCES

- (1) L. G. Augenstine, J. G. Carter, D. R. Nelson and H. P. Yockey, *Radiation Research, Supplement*, 2, 19 (1960).
- (2) L. G. Augenstine, J. G. Carter, D. R. Nelson and H. P. Yockey, "Thermoluminescence of Irradiated Proteins and Amino Acids", edited by M. Blois (Academic Press, New York and London, 1960) p. 149.