

Title	A New Vacuum Disk Valve
Author(s)	Yasumi, Shinjiro; Yuasa, Kazunori; Sakisaka, Masakatsu; Oyama, Yoshito
Citation	Bulletin of the Institute for Chemical Research, Kyoto University (1954), 32(2): 73-74
Issue Date	1954-03-31
URL	<a href="http://hdl.handle.net/2433/75433">http://hdl.handle.net/2433/75433</a>
Right	
Type	Departmental Bulletin Paper
Textversion	publisher

to be obtained with roughly 100 watts of total A. C. power input (including all the oscillator tube and rectifiers) by the use of four permanent magnets arranged as described by Little et al. (*Rev. Sci. Instr.* 23., 768, (1952)).

The relation between the maximum beam output and the gas pressure is shown in Fig. 1. For stronger magnetic field and rf power input, the beam current peak widens and shifts to the region of higher gas pressure. The variation of the beam current with the probe voltage is shown in Fig. 2 for various magnetic field and rf power input.

## 2. A New Vacuum Disk Valve

Shinjiro YASUMI, Kazunori YUASA, Masakatsu SAKISAKA and Yoshito OYAMA

(K. Kimura Laboratory)

A compact and low impedance vacuum valve has been designed and constructed to install in the evacuating system of their 400-keV ion accelerator.

The essential part of this valve is a metal disk D rolling on a seesaw S. The disk is easily positioned at I or II (Fig. 1) through the change of the inclination of S

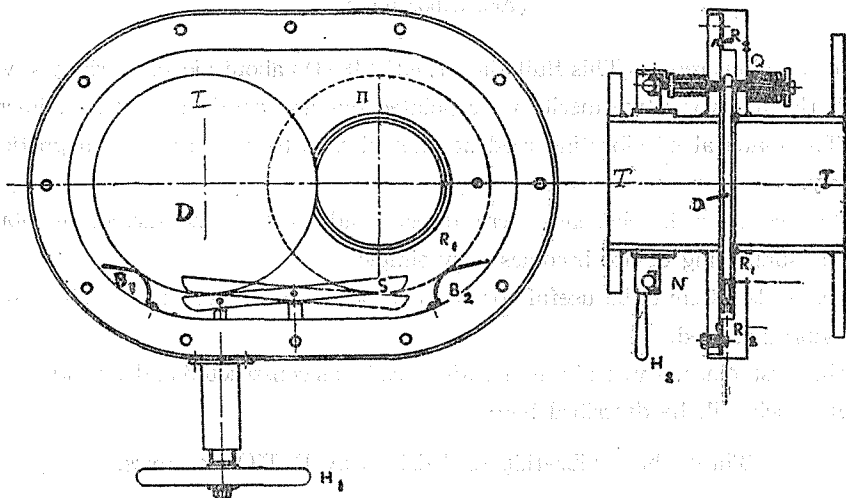

Fig. 1. Schematic diagrams of seesaw disk valve.

$R_1, R_2$ : Rubber gaskets

D: Metal disk

S: Seesaw

$H_1, H_2$ : Handles

P, Q: Pushing rods

N: Screw

$B_1, B_2$ : Springs

T: Tube

which is caused by two or three turnings of the handle  $H_1$ .

To close the valve, the disk is positioned at II by the handle  $H_1$ , and then on turning the handle  $H_2$  it is pressed against the rubber gasket  $R_1$  by the three rods  $P_1, P_2, P_3$ , which move keeping pace with each other.

The valve is opened by the reverse operations.

The remarkable features of this valve are as follows :

- 1) By the utilization of the gravity the mechanism is very simple, and we call it "seesaw" disk valve.
- 2) The necessary strokes of the handle  $H_1$  and pushing rods  $P$ 's are very small, and almost independent of the valve size.
- 3) For the vacuum seals of all the movable part slyphon bellows are used.
- 4) Simple in construction and compact in size.

From these features, this design seems also favourable for extremely large vacuum valves.

---

### 3. Poly-phase Vibrating Reed Driven by Piezoelectric $BaTiO_3$ Ceramics

Kiyoshi ABE, Tetsuro TANAKA, Toshio INOYUCHI and Akira MURATA

(Abe Laboratory)

In the previous report (This Bulletin, **31**, 421 (1953)) about piezoelectric type vibrating reed, the following two merits were pointed out and confirmed by experiments.

- (i) The material of vibrating reed has not always to possess ferromagnetic property.
- (ii) As piezoelectric elements were directly adhered on the surface of vibrating reed, supporting device becomes very simple.

These merits also seem to be useful for the purpose to generate the polyphase oscillation by vibrating reed.

In the first place, three phase vibrating reed was constructed and investigated, the result of which will be described here.

#### Three phase vibrating reed driven by $BaTiO_3$ ceramics.

To produce the polyphase oscillation by mechanical vibrator, it is necessary that the vibrator is axially symmetric, and the most ideal form seems to be lanky column. But since plane surfact is desired to which piezoelectric elements are adhered, a hexagonal prism was adopted in this experiment.

Fig. 1 shows the plane development of hexagonal prism for the sake of explanation. At the nodal position, two groups of piezoelectric elements ( $A_1 B_1 C_1, A_2 B_2 C_2$ ) were adhered and two groups of supporting holes ( $D_1 E_1 F_1, D_2 E_2 F_2$ ) were drill-