

Title	Study on High Dielectric Constant Ceramics. (XXIII) The Modes of Vibration about Langevin Type BaTiO Ceramic Vibrator. (3)
Author(s)	Abe, Kiyoshi; Tanaka, Tetsuro; Inoguchi, Toshio; Murata, Akira
Citation	Bulletin of the Institute for Chemical Research, Kyoto University (1954), 32(2): 78-80
Issue Date	1954-03-31
URL	http://hdl.handle.net/2433/75430
Right	
Type	Departmental Bulletin Paper
Textversion	publisher

Eqs. (3) and (4) give the curves very approximate to that of Fig. 1. Eqs. (5) (6) are inferior to eqs. (3) and (4) in the approximation to the measured curve. Eqs. (5) and (6) were used in calculation, though the degree of approximation are inferior to eqs. (3) and (4), because their integration can not be solved when the eq. (3) or (4) is inserted in eq. (1). When eq. (5) was used, we have with $\alpha = -1.5$, $\beta = 6.5$ and $\gamma = -1$,

$$R = 4.6 \frac{\sin u}{u} + 8.05 \frac{\cos u}{u^2} + 5.80 \frac{\sin u}{u^3} + 41.5 \frac{\cos u}{u^4} - 43.3 \frac{\sin u}{u^5} \quad (7)$$

When the values of R are calculated for every values of δ , the directional characteristic curve is obtained as shown in Fig. 2. When eq. (6) was used, we have with $\beta = 5$ and $\gamma = -1$,

$$R = 6 \frac{\sin u}{u} + 15 \frac{\cos u}{u^2} - 15 \frac{\sin u}{u^3} \quad (8)$$

This result is shown in Fig. 3.

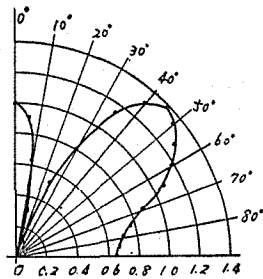

Fig. 2.

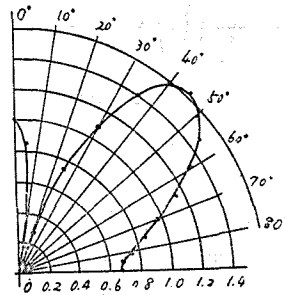

Fig. 3.

It may be said that they coincide qualitatively with the directional characteristics measured really in water.

5. Study on High Dielectric Constant Ceramics. (XXIII)

The Modes of Vibration about Langevin Type BaTiO₃ Ceramic Vibrator. (3)

Kiyoshi ABE, Tetsuro TANAKA, Toshio INOYUCHI and Akira MURATA

(Abe Laboratory)

As a cylindrical Langevin type vibrator has simple construction and is manufactured easily, it has already been practically used as an underwater supersonic transducer. Recently, the rectangular Langevin type vibrator is also required from a view point of the directional characteristics, and so, such vibrator was made and the modes of vibration were inspected.

Rectangular Langevin Type Vibrator

The size of the vibrator is 100 mm. in length and 30 mm. in width and total thickness including piezoelectric material (2 mm. in thickness) is 44 mm. Consequently the thickness of two iron pieces are 21 mm. This vibrator was made for the purpose to utilize the thickness vibration, however, it is presumed that it has at least two resonant frequencies besides the thickness vibration. The measured resonant frequencies were 25.31 kc, 52.78 kc and 97.40 kc and they were called the first, the second and the third resonance respectively. The vibration in the second resonance is strongest among them, and assuming that the vibration has simple longitudinal mode the calculated force factor becomes 16.3×10^7 dynes/e. s. u. volt. In the third resonance, force factor is 9.24×10^7 . The first resonance is very weak.

Generally speaking, the first, the second and the third resonances correspond to the longitudinal vibration of length, thickness and width direction respectively. It is presumed that in the second and the third resonance the modes of vibration are complicated on account of coupled vibration due to the similarity of both size.

Method and Result of Measurement

The amplitude distribution and the phase relation on the vibrator surface are measured by using a pick-up, which consist of a small Langevin type vibrator, as is detailed in the Part 1. (This Bulletin, **31**, 295 (1953)). The results of measurement are shown in Fig. 1 and Fig. 2, which show the modes of vibration in the first and the second resonance respectively. In these figures, the sign of + or - represents the phase relation, that is, all the amplitude distributions are shown by the convex surfaces for the sake of convenience. In the third resonance, the motion has not the same phase on the surface and the figure is omitted because it is too complicated to draw.

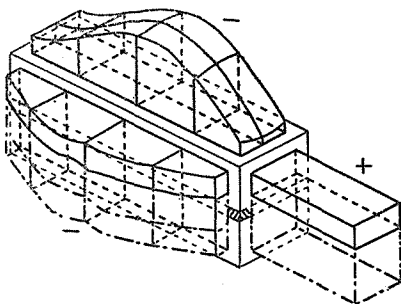

Fig. 1.

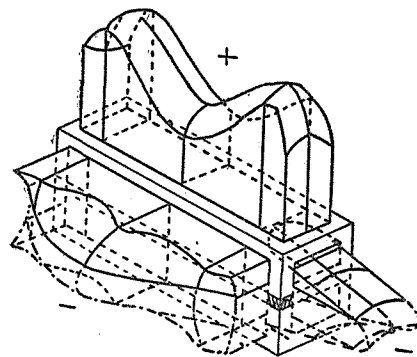

Fig. 2.

Consideration

The vibration in the first resonance is undoubtedly the longitudinal vibration of length direction, as the results of measurement on the amplitude distribution prove it. In the second resonance, it is concluded that this vibration is nearly equal to longitudinal

thickness mode. In the third resonance, although comparatively strong vibration is excited as is presumed from the measurement of motional admittance, it is not desirable to use this resonance for the acoustic purpose, because the amplitude distribution is complicated and the directional characteristics of vibrator suffer harmful influences by the existence of the part of inverse phase on a radiating surface. It is concluded that the second resonance is the most effective among them.

6. Study on Surface Electricity. (XIX)

Capacity Measurement of Dropping Mercury Electrodes by Resonance Method. (1)

Akira WATANABE, Fukuju TSUJI and Shizuo UEDA

(Tachi Laboratory)

As the interfacial phase between mercury and electrolytic solution is considered to be equivalent to an A. C. element containing a capacitance, a resonant circuit is constructed by connecting it with an inductance. This circuit satisfies the resonance condition when the following equation exists,

$$f = 1/(2\pi\sqrt{LC})$$

where f is the frequency, and L and C are the inductance and capacitance, respectively.

The interfacial area of a dropping mercury electrode increases continuously with time, which can be represented by

$$A = 4\pi \left[\frac{3mt}{13.6 \times 4\pi} \right]^{\frac{2}{3}}$$

where A is the interfacial area, m the rate of flow of mercury (g./sec.) and t is time. As the (differential) capacity per unit interfacial area takes its unique value (at a given polarization), the total capacitance of the interface increases with time, i. e.

$$C = C_0 A = C_0 k t^{2/3}$$

where C is the total capacitance, C_0 the specific capacity per unit area and k is constant for a given value of m .

Combining this equation and the above condition for resonance, we can conclude that, by choosing proper A. C. frequency and inductance, the circuit resonates at some instance during the growth of the mercury drop. The resonance curve can be reproduced on the screen of a cathode ray oscilloscope by applying the A.C. voltage occurring at the two terminals of the dropping electrode cell as the vertical axis and a