

Title	Decomposition of t-Butanol Induced by Methyl Radicals
Author(s)	Takezaki, Yoshimasa; Masumoto, Hatsuhiko
Citation	Bulletin of the Institute for Chemical Research, Kyoto University (1953), 31(4): 267-279
Issue Date	1953-07-30
URL	http://hdl.handle.net/2433/75344
Right	
Type	Departmental Bulletin Paper
Textversion	publisher

4. Decomposition of *t*-Butanol Induced by Methyl Radicals

Yoshimasa TAKEZAKI and Hatsuhiko MASUMOTO*

(Kodama Laboratory)

Received May 23, 1953

INTRODUCTION

In the previous report on the methyl-radical-induced decomposition of ethanol^{1,2)} we suggested that the primary attack of free radical occurs almost exclusively at the α C-H bond, not at O-H, and that the next step is the splitting of O-H to form acetaldehyde. As discussed by Phibbs and Darwent³⁾ and by us^{4,5)}, this must also be the case for methanol having only one primary carbon, though we have no conclusive evidence as yet on this matter.

What will happen in *t*-butanol in which all the C-H bonds are of the primary and O-H is bound to the quarternary C, and accordingly the formation of stable molecule by two successive dehydrogenations is impossible structurely ?

The principal object of the present work is to determine the initial attack point of methyl and to elucidate the step next to the first dehydrogenation.

EXPERIMENTAL

Static method was used ; the reaction equipment was the same as illustrated in the previous paper¹⁾ (reaction bulb, 260 cc, surface/volume=1 cm⁻¹ ; constancy of reaction temperature = $\pm 0.2^\circ\text{C}$; accuracy of pressure measurement = 0.1 mm Hg).

A small amount of azomethane was introduced into the butanol kept at the reaction temperature, then the pressure change was pursued ; at the required moment major part (80 %) of the reaction mixture was withdrawn into an evacuated vessel of 260 cc, shaken with 10 cc water, and half of the gaseous products thus collected (in total ca. 15 cc) were analysed by a modified Ambler's apparatus (accuracy in reading = 0.005 cc).

The amount of isobutylene was determined by the absorption with 70 % H₂SO₄ (repeated three times, each with fresh acid; volume contraction between the third and the fourth absorptions was ca. 0.01 cc, and the reading of the third was taken). *N*-butylene+propylene was determined with 88 % H₂SO₄, and ethylene with 104 % H₂SO₄+0.3 % Ag₂SO₄.

Hydrogen was not found by the partial combustion with CuO, and so the total gaseous paraffins were exploded with pure O₂ and the carbon number was assigned to methane and ethane (and hexane) according to the mechanism proposed below.

* 竹崎嘉真・増本巴部彦

The amount of acetone in the aqueous solution was determined by iodoform reaction (aliquot 5 cc; microtitration with 0.1 *N* thiosulfate). As to the other products description will be given later.

Preparation and purification of azomethane were the same as given in the previous paper¹⁾. *T*-butanol of c.p. grade was distilled repeatedly over molten KOH, then frozen at 23°C; the solid portion was used.

RESULTS

In Figure are given the results obtained under the following conditions: the initial pressure of butanol=470±5 mm; the initial pressure of azomethane=23±1 mm; accordingly the ratio of initial pressures=20.5; the reaction temperature=309°C.

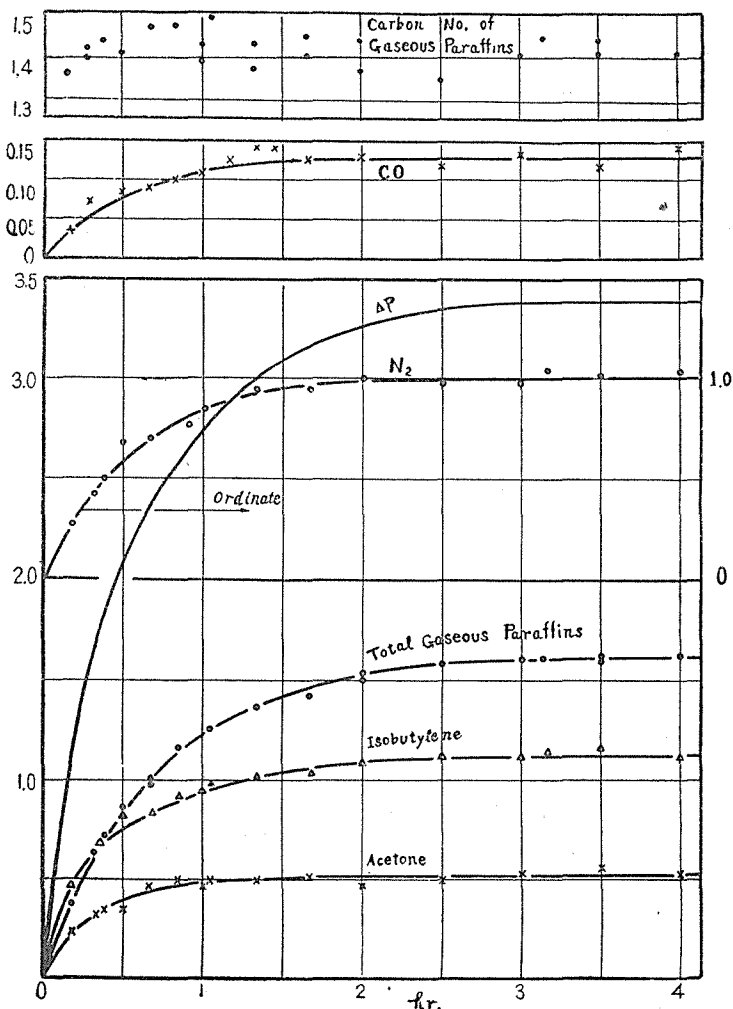

Observed pressure rise and the reaction products.
Ordinate denotes the ratio to the initial pressure of azomethane.

Decomposition of *t*-Butanol Induced by Methyl Radicals

The numerical values concerning the amount of pressure rise or of products are given by the ratio to the initial pressure of azomethane throughout the paper.

No positive evidence of the presence of H₂ was found in the difference of carbon numbers obtained from the explosion which were carried out before and after the CuO treatment at 230°C.

The amounts of *n*-C₄H₈+C₃H₆ and C₂H₄ seem to increase as the reaction proceeds, but they do not exceed 0.05 and 0.03, respectively, at the end of the reaction.

The formation of N₂ agrees with the calculated amount according to the equation CH₃N₂CH₃=2CH₃+N₂ and its rate constant (=5.3×10⁻⁴ sec⁻¹ at 309°C) obtained previously¹⁾.

The sum of formaldehyde and acetaldehyde in the aqueous solution, estimated colorimetrically with Schiff's reagent, did not exceed 0.01 throughout the reaction period.

There is some product which is positive to the iodoform reaction; but since the iodine consumption remained constant after the treatment of the aqueous sample with 0.1 M KMnO₄ and 3% H₂O₂ it is hardly attributed to the presence of ethanol. Hence, to be consistent with the mechanism suggested by other sources of evidence too, it seems best to identify this product with acetone; in Figure are given the amounts of this product calculated as acetone.

Methanol was not detected by Schiff's reagent after the sample was treated with 0.1 M acidic KMnO₄. There existed quite a small amount of some substance in the aqueous products, which produced HCHO by the action of HIO₄. The formation of water in the reaction mixture was confirmed by CoCl₂ paper inserted into the sampling vacuum vessel.

pH of the aqueous solution was 7.2-7.4, and it was slightly turbid in white. The solution did not become clear after standing for many months, and the turbidity did not disappear by boiling or by the action of hypiodite, periodate, or Schiff's reagent. It did not dissolve in ammonia or dil. H₂SO₄; nor in organic solvents such as ether, methanol, chloroform, CCl₄ and benzene. In conc. H₂SO₄ it dissolved in brown color, and by HBr or bromine water it was changed into a substance which was insoluble in water but soluble in ether; the melting point of this derivative was higher than 100°C. On evaporation of water, the aqueous sample left whitish thin film, which, a microscopic inspection disclosed, consisted of amorphous solid and some oily matter; the solid part did not melt at 100°C.

DISCUSSION

The species of the observed products suggest the following mechanism :

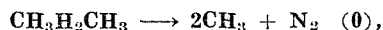

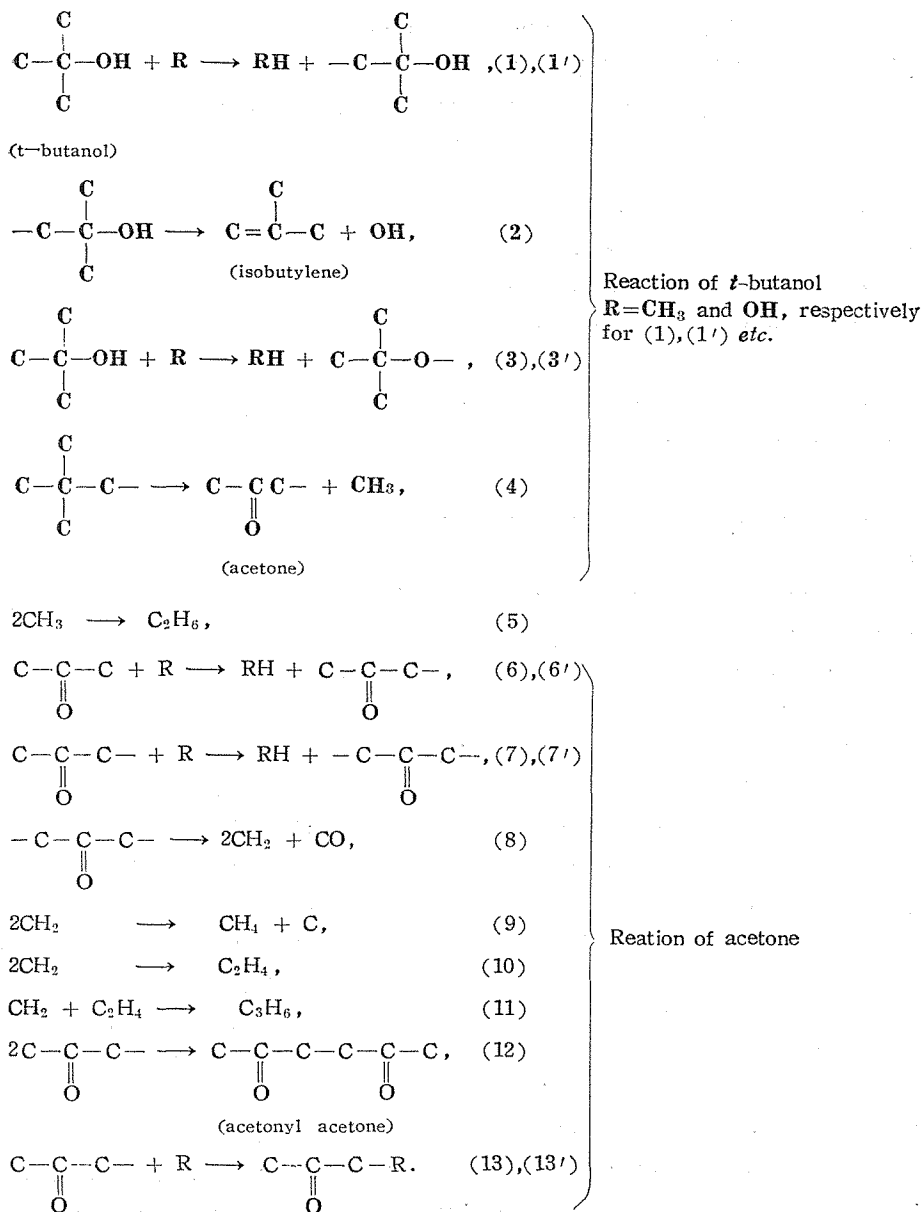

It may be natural to assume the reactions (1), (1') and (2) to explain the formation of water and isobutylene. If the formation of acetone is accepted, we can write (3), (3') (4) as a possibility for this; (4) has been frequently proposed in the thermal decomposition of di-*t*-butyl peroxide. Small amount of CO, C₂H₄ or C₃H₆ (here, absence of *n*-butylene is assumed) is supposed to be derived from the secondary reactions of acetone, (6)-(13'), which were proposed by us in the methyl-radical-induced decomposition of acetone¹⁾⁶⁾.

Decomposition of *t*-Butanol Induced by Methyl Radicals

Besides them, mutual combinations of radicals,

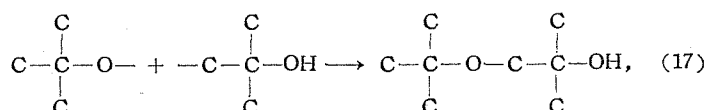
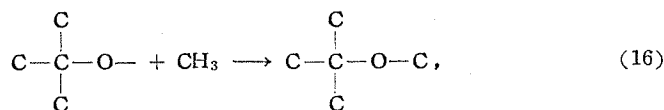
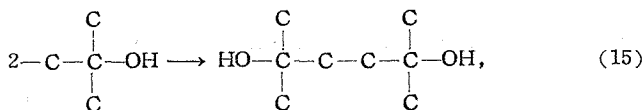
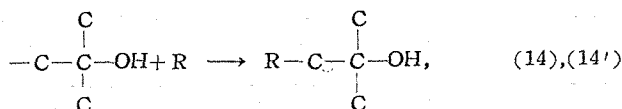

may take place.

However, the formation of the substance which causes turbidity in the aqueous solution (referred to as "X" hereafter) cannot be explained by these elementary reactions because of the properties of X (solubilities, melting point etc.) which cannot be identified with those of these products. Furthermore, we have to consider the subsequent reactions of isobutylene, since, for instance, the reaction $\text{CH}_3 + i\text{C}_4\text{H}_8 \rightarrow \text{CH}_4 + i\text{C}_4\text{H}_7$ is not supposed to be much slower than $\text{CH}_3 + \text{CH}_3\text{COCH}_3 \rightarrow \text{CH}_4 + \text{CH}_3\text{COCH}_2$ (recalculation of the results given by Trotman-Dickenson and Steacie⁷⁾ shows that the former is faster than the latter by a factor of 1.3 at 310°C) and here the steady concentration of isobutylene is higher than that of acetone. (As shown below, these isobutylene reactions do not account for the formation of X.)

Now, if we neglect tentatively these unknown reactions, we have, from the material balance,

$$\Delta p = (\text{C}_2 + \text{C}_4' + \text{AcH} + 4\text{CO} - 0.5\text{C}_3') + \{\text{C}_6\text{OH} + \text{C}_4(\text{OH})_2 + \text{C}_8(\text{OH})_2 + \text{C}_4\text{OC}_1 + \text{C}_4\text{OC}_4\text{OH} + 3\text{AcAc} + 2\text{AcCH}_3 + 2\text{AcOH}\}, \quad (\text{A})$$

$$\Delta p = (\text{C}_1 + \text{C}_2 + \text{C}_2' + \text{C}_3' + \text{C}_4') - \{\text{C}_4(\text{OH})_2 + \text{C}_8(\text{OH})_2 + \text{C}_4\text{OC}_4\text{OH} + \text{AcAc} + \text{AcOH}\}, \quad (\text{B})$$

$$\text{AcH} = (\text{C}_1 + \text{C}_2' + 1.5\text{C}_3' - 4\text{CO}) - \{\text{C}_6\text{OH} + 2\text{C}_4(\text{OH})_2 + 2\text{C}_8(\text{OH})_2 + \text{C}_4\text{OC}_1 + 2\text{C}_4\text{OC}_4\text{OH} + 4\text{AcAc} + 2\text{AcCH}_3 + 3\text{AcOH}\}, \quad (\text{C})$$

$$(\text{Decomposed Azomethane}) = (\text{C}_2 + \text{CO}) + \{\text{C}_6\text{OH} + \text{C}_4(\text{OH})_2 + \text{C}_8(\text{OH})_2 + \text{C}_4\text{OC}_1 + \text{C}_4\text{OC}_4\text{OH} + \text{AcAc} + \text{AcCH}_3 + \text{AcOH}\}, \quad (\text{D})$$

Table of abbreviations, C_1 $\text{C}_4(\text{OH})_2$ etc, is given on the next page.

Introduction of the observed values concerning the products at the end of the reaction, *i.e.*, $\text{C}_1 = 0.96$, $\text{C}_2 = 0.64$ (calculated from total paraffins = 1.60 and C. No. = 1.40 ; C_2 is too much as compared with C_1 !!), $\text{C}_2' = 0.03$, $\text{C}_3' = 0.05$, $\text{C}_4' = 1.10$, $\text{AcH} = 0.54$, $\text{CO} = 0.13$ gives

Table of abbreviations.

C ₁	C ₂	C ₂ '	C ₃ '	C ₄ '	C ₅ OH	C ₄ (OH) ₂	C ₈ (OH) ₂	
					(14)	(14')	(15)	
CH ₄	C ₂ H ₆	C ₂ H ₄	C ₃ H ₆	<i>i</i> C ₄ H ₈	$\begin{array}{c} \text{C} \\ \\ \text{C}-\text{C}-\text{C}-\text{OH} \\ \\ \text{C} \end{array}$	$\begin{array}{c} \text{C} \\ \\ \text{HO}-\text{C}-\text{C}-\text{OH} \\ \\ \text{C} \end{array}$	$\begin{array}{c} \text{C} \\ \\ \text{C}-\text{C}-\text{C}-\text{C}-\text{C} \\ \quad \\ \text{OH} \quad \text{OH} \end{array}$	
C ₄ OC ₁			C ₄ OC ₄ OH		AcH	AcAc	AcCH ₃	AcOH
(16)			(17)		(12)	(13)	(13')	
Me- <i>i</i> Bu- ether			$\begin{array}{c} \text{C} \\ \\ \text{C}-\text{C}-\text{O}-\text{C}-\text{C}-\text{OH} \\ \quad \\ \text{C} \quad \text{C} \end{array}$	Acetone	Acetyl- acetone	Me-Et-ketone	$\begin{array}{c} \text{C}-\text{C}-\text{C}-\text{OH} \\ \\ \text{C} \end{array}$	

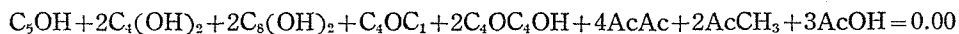

from (C), and then

$$\Delta p_{\text{calc}} = 2.78 < \Delta p_{\text{obs}} = 3.40$$

from (A) or (B), and

$$\text{Decomposed Azomethane calc.} = 0.77 < \text{Introduced Azomethane} = 1.00$$

from (D).

That is, the mechanism based on the identified products only is far from sufficient to explain the observed facts, and we must search the other reactions which consume radicals amounting to 0.46 and cause the pressure rise of 0.62.

Contrary to this, however, if we adopt this mechanism to the reaction of CH₃O (produced by pyrolysis of dimethyl peroxide) with *t*-butanol at 167°C (initial pressures were the same as the present experiment), where no isobutylene was formed, the calculated Δp is in fair agreement with the observed, or at least it does not conflict with the latter.

In this case the final amounts of reaction products were :

$$\text{C}_1 = 0.14, \text{C}_2 = 0.08, \text{CO} = 0.21, \text{C}_2' = 0.02, \text{C}_3' = 0.00, \text{C}_4' = 0.01 \text{ and } \Delta p = 1.09.$$

From the mechanism,

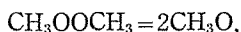

and the reactions (1)-(5) and (14)-(17), where R=CH₃, OH and CH₃O, and

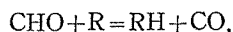
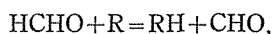

Decomposition of *t*-Butanol Induced by Methyl Radicals

(the last three have been proposed in our another report on the reaction of methoxy radicals with methanol⁷⁾), we have:

$$\Delta p = (\text{Decomposed Peroxide}) + C_1 + C_2 + C_4' - \{C_4(\text{OH})_2 + C_1\text{OC}_4\text{OH} + C_4\text{OC}_4\text{OH} + C_8(\text{OH})_2\} = 1.23 - \{2C_4(\text{OH})_2 \text{ etc.}\}, \quad \Delta p_{\text{obs}} = 1.09.$$

On the other hand, a larger amount of *X* was formed in this reaction; therefore it is supposed that *X* is produced by such reactions that do not affect the pressure rise ultimately, or if they do, they would rather cause a slight increase of Δp , (at most 0.14 even when *X* is produced in a large quantity).

With respect to the formation of *X*, the following facts have been observed: 1) under the same experimental condition as the present, *X* is not formed in the reaction of CH_3 with acetone, or CH_3 with isobutylene or their mixture; 2) as mentioned above, the reaction of CH_3O with *t*-butanol, where no isobutylene is formed, produces a larger amount of *X*. From these observations we can say 1) the radicals derived from acetone and isobutylene are not contained in the structure of the molecule of *X*, 2) at least CH_3O and OH are not the necessary constituent of *X*, and finally 3) *X* is derived from the radicals produced primarily from *t*-butanol by the attack of radicals, but its formation should not be accompanied with pressure decrease, *i.e.*, it can neither be the polymerisation product nor the recombination product of *t*-butanol radical with radicals other than CH_3 .

As stated before, the only possible products in the above mechanism, which do not conflict with these restrictions, C_8OH and C_4OC_1 , cannot be regarded as *X*.

On the other hand, we can suppose the reaction

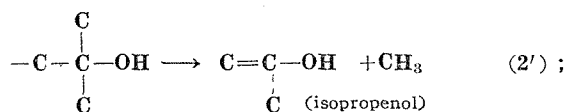

this reaction may occur more easily than (2) since the C-C bond is weaker than C-O. If this reaction is assumed, explanation of the formation of *X* becomes possible under some proper premises.

As is vinyl alcohol, isopropenol is supposed to be far more unstable thermodynamically than its keto-form, acetone, even at 309°C, ($\Delta H \approx +13\text{kcal/mole}^{9)}$; no trace of isopropenol was found in acetone at room temperature (K. H. Meyer⁹⁾) and it is said that acetone is formed in the hydrolysis of isopropenyl ether¹⁰⁾. However, the keto-enol tautomerism has been recognized as an ionic reaction (for instance,

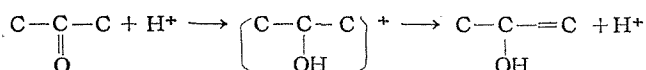

as proposed in the acid accelerated bromination of acetone), and it seems very improbable that the isopropenol produced in the present experiment is readily converted

into acetone in the vapor phase intramolecularly by the transference of H atom to the remote C (cf. J. B. Conant¹¹⁾).

Strictly speaking, the conversion might occur at the wall or by the intervention of, *e.g.* water vapor which may facilitate the migration of H intermolecularly when it collides with isopropenol, but this must not be so under the present experimental condition, *i.e.*, low partial pressures and low S/V ratio of the reactor, because if it occurs with a measurable but slow velocity the acetone curve should not become horizontal in its tail.

Analogously to vinyl alcohol, it seems quite plausible that the formation of polyisopropenol or similar complex high polymer takes place under some proper condition; the properties of X (colloidal suspension, amorphous, film formation, solubilities, high melting point, behaviors against HBr or bromine water) do not seem to contradict the identification of X with such heat-treated high polymer. But no polymerisation is supposed to take place in the reactor, judging from the behavior of polyvinyl alcohol at high temperature, which has been reported to be disintegrated completely into acetaldehyde, water, crotonaldehyde and higher olefins at 250-340°C¹²⁾.

Therefore, to avoid the difficulty that the polymerisation in the reactor reduces Δp in eq. (B) too, we are forced to assume that isopropenol polymerises quickly at a proper temperature between the reaction and the room temperatures while we take out the reaction mixture, so long as X is considered to be the polymer. This assumption may be justified from the analogy of vapor phase polymerisation of vinyl compounds.

The isopropenol may be attacked further by radicals in the reactor; we can write many reactions, *e.g.*,

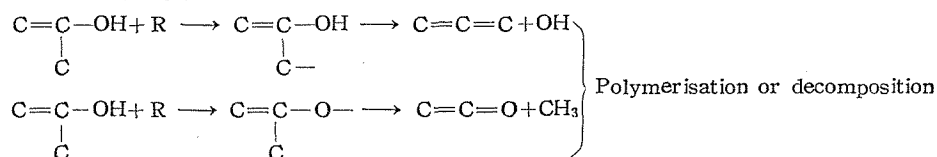

but at the present stage they are too speculative to be assumed.

Thus, as a possible explanation for the formation of X, we are to assume "Isopropenol is produced by (2') and it is stable enough to stay in enol-form in the reactor, and it polymerises during the withdrawal of reaction mixture."

For the reactions of isobutylene we take the following reactions into consideration :

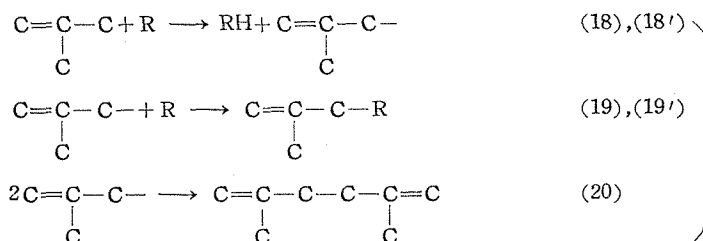

Decomposition of *t*-Butanol Induced by Methyl Radicals

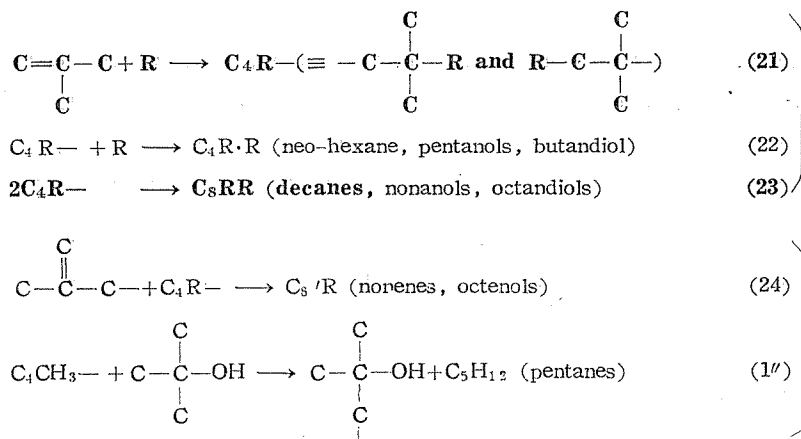

Isobutylene is stated to inhibit the decomposition of hydrocarbons¹⁹; probably its inhibition mechanism is analogous to that of propylene and consequently, in the present case, chain must be terminated by the reaction of isobutylene rather than $2\text{CH}_3 \rightarrow \text{C}_2\text{H}_6$. However, the detail of inhibition mechanism of propylene or isobutylene, it seems, is not yet clear. Especially, as to the relative velocity of the two modes of primary step, (18) and (21), at about 309°C, data so far reported are rather conflicting.

Among them, for instance, the observation* of Rust *et al.*¹⁹ (CH_3 from di-*t*-butyl peroxide at 235°C) suggests 1) the initial addition of CH_3 to the double bond of isobutylene occurs to the extent comparable to the abstraction of H, 2) isopentyl radical (formation of neopentyl radicals is not clear while evidence of the occurrence of the addition of CH_3 to the central carbon of propylene is given in the same paper) converts into isopentane by abstraction of H from molecule, 3) recombination of isobutenyl radicals, (20), does not occur though similar reaction was suggested in propylene by Taylor and Smith¹⁹.

On the other hand, Trotman-Dickenson and Steacie²⁰ stated recently that they observed no evidence of the addition of CH_3 to the double bond or of polymerisation at 170-300°C in the reaction of CH_3 (released from acetone by photolysis) with isobutylene. However, in our preliminary experiment of the similar reaction (CH_3 from azomethane (24 mm.) and isobutylene (410 mm.) at 310°C), no pressure rise was observed (rather, though quite slightly, the pressure decreased). If the primary step (18) stated by Trotman-Dickenson *et al.* occurs, we have to assume at least the simultaneous occurrence of the reactions such as (21) and (23) to account for the

* Their observation is reproduced here :

Product :	<i>t</i> -Amylene	Isopentane	Neohexane	Nonenes	Decanes
Relative amount :	8.5	7.5	6.0	2.0	2.0
Mechanism :	18, 19	21, 1''	21, 22	18, 24	21, 23

constancy of pressure.

Such being the case, we take almost all the possible courses (for the pentane formation, only (1'') is assumed which is considered to be predominant) and try to determine the extents of their contributions from material balance.

The material balance based on the above-mentioned mechanism, (0)-(24), are :

$$\Delta p = (C_2 + C_6 + C_{10}) + C_4' + 2C_6' + 2C_9' + 3C_8'' + P + (AcH + 4CO - 0.5C_3') + x \quad (A')$$

$$x = C_6OH + C_9OH + 2C_4'OH + 2C_8'OH + C_4(OH)_2 + C_8(OH)_2 + C_4OC_1 + C_4OC_4OH + 3AcAc + 2AcCH_3 + 2AcOH$$

$$\Delta p = (C_1 + C_2 + C_5 + C_6 + C_{10}) + (C_2' + C_3' + C_4' + C_6' + C_9') + C_8'' - y \quad (B')$$

$$y = C_4(OH)_2 + C_8(OH)_2 + C_4OC_4OH + AcAc + AcOH$$

$$AcH = (C_1 + C_5) - (C_6' + C_9' + 2C_8'') - P + (C_2' + 1.5C_3' - 4CO) - z \quad (C')$$

$$z = C_6OH + C_9OH + 2C_4'OH + 2C_8'OH + 2C_4(OH)_2 + 2C_8(OH)_2 + C_4OC_1 + 2C_4OC_4OH + 4AcAc + 2AcCH_3 + 3AcOH$$

$$2(\text{Decomposed Azomethane}) + AcH + 2CO - C_2' - 1.5C_3' = (C_1 + C_6 + 2C_6 + 2C_{10})$$

$$+ (C_6' + C_9') - P + u \quad (D')$$

$$u = C_6OH + C_9OH + C_4OC_1 - 2AcAc - AcOH$$

$$(\text{Decomposed Azomethane}) = (C_2 + C_6 + C_{10}) + (C_6' + C_9') + C_8'' + CO + v \quad (E')$$

$$v = C_6OH + C_9OH + C_4'OH + C_8'OH + C_4(OH)_2 + C_8(OH)_2 + C_4OC_1 + C_4OC_4OH + AcAc + AcCH_3 + AcOH.$$

where

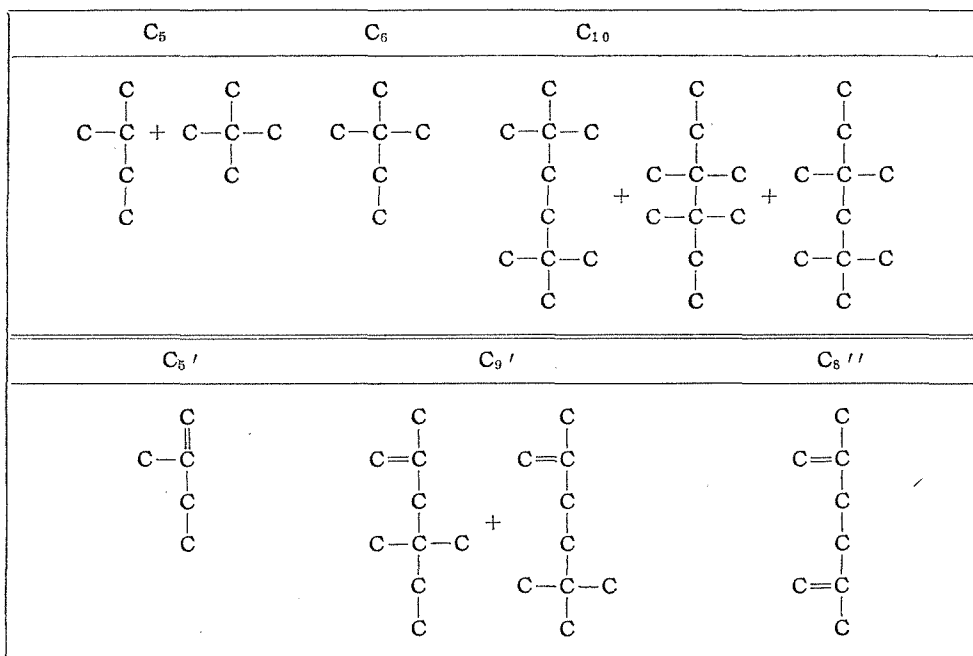

Decomposition of *t*-Butanol Induced by Methyl Radicals

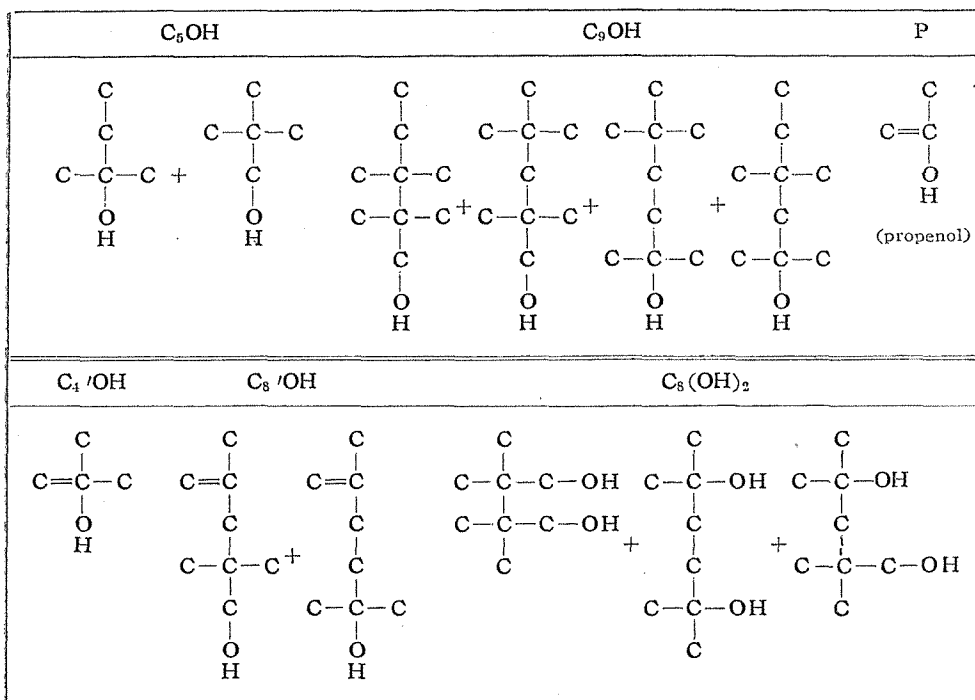

Under the conditions of gas analysis (residual gas volume to be analysed further and temperature), those parts of paraffins and olefins which do not exceed the following amount respectively should come into gaseous phase :

C_5 and C_5'	C_6	C_8''	C_9'	C_{10}
2.2	0.7	0.05	0.01	0.005 .

So, we can safely assume that all the C_5 , C_5' and C_6 produced stay in gaseous phase and all the C_9' and C_{10} are condensed out. As to C_8'' we divide the case into two.

(I) If $C_8'' \leq 0.05$:

At the end of the reaction, we have,

$$C_4' + C_5' + C_8'' = 1.10,$$

$$C_5 + C_9' + C_{10} = 0.62 + y,$$

$$C_8'' + C_9' + P = 0.40 - (x - v), \quad (x - v = C_4'OH + C_8'OH + 2AcAc + AcCH_3 + AcOH > y + v),$$

$$C_1 + C_6 = 1.61 - (y + u/2 + x - v - z/2) = 1.61,$$

$$C_3' + C_8'' + y + v = 0.25 - C_2 - C_6 + C_5, \quad (v = y + C_5OH + C_9OH + C_4'OH + C_8'OH + C_4OC_1 + AcCH_3),$$

$$C_1 + C_2 + C_5 + C_6 = 1.60 \text{ (obs.)},$$

$$C_1 + 2C_2 + 5C_5 + 6C_6 = 2.24 \text{ (C.No.)}.$$

Hence we get,

$$\begin{cases} C_1=1.47, C_2=0.00, C_3=0.00, C_6=0.13 \\ 0.06 \leq C_5' + C_8'' + \Sigma \text{ all oxygen compounds except AcH and P} \leq 0.12; y \leq 0.06 \\ 0.62 \leq C_9' + C_{10} \leq 0.67, \\ 0.40 \geq C_9' + P \geq 0.28, \\ 1.10 \geq C_4' \geq 0.98. \end{cases}$$

(II) If $C_8'' > 0.05$:

$$\begin{aligned} C_4' + C_6' &= 1.05, \\ C_5 + C_9' + C_8'' + C_{10} &= 0.67 + y, \\ 2C_8'' + C_9' + P &= 0.45 - (x - v), \\ C_1 + C_6 &= 1.61 - (y + u/2 + x - v - z/2) = 1.61, \\ C_5' + w &= C_1 + C_5 - 1.41, \quad (w = z - x + v = v + y) \\ &\quad (w > 2y) \end{aligned}$$

Hence,

$$\begin{cases} C_1=1.47, C_2=0.00, C_3=0.00, C_6=0.13, \\ C_5' + \Sigma \text{ all oxygen compounds except AcH and P} \leq 0.06; y \leq 0.03, \\ 0.67 \leq C_8'' + C_9' + C_{10} \leq 0.70, \\ 0.45 \geq 2C_8'' + C_9' + P \geq 0.39, \quad (x - v < w) \\ 1.10 \geq C_4' \geq 0.98. \end{cases}$$

From the above results it is deduced that the main chain terminating steps are the secondary reactions of isobutylene. It seems better to assume $C_9' \approx 0$ and $C_8'' \approx 0$ in the relations $C_9' + P$ and $2C_8'' + C_9' + P$ because of the appreciable formation of X ; then it becomes probable that the reactions which begin with $C_4H_8 + CH_3 \rightarrow C_6H_{11}-$ are predominant (especially formation of C_{10}), and that those which begin with $C_4H_8 + R \rightarrow RH + C_4H_7-$, the addition of OH and the reactions of acetonys take place only slightly. And, the majority of OH radicals which correspond to the amount of those produced by (1) are converted again into CH_3 by (2') and (4). The absence of ethane seems consistent with the results obtained in the reaction of CH_3 with methanol, ethanol, dimethyl ether, formaldehyde, or acetone reported before¹⁾, and the presence of higher paraffin vapors is suggested to some extent from the fairly larger fluctuation of observed carbon numbers as compared with other cases (methanol etc¹⁾).

So far, we have assumed that the formation of acetone is solely due to the reactions (3), (3') and (4). Among other possibilities, the following two may be ruled out: a) the equilibrium between keto-enol form of isopropenol becomes measurable at 310°C and this is attained quickly even in the vapor phase, b) isopropenol does not entirely polymerise when it is taken out and the remaining part is converted into acetone in the aqueous solution. Because, if (a) is true, acetone should produce X when it is heated to 310°C, which is contrary to the observation; and (b) seems improbable since the shape of the acetone curve is regular, and moreover it is impos-

Decomposition of *t*-Butanol Induced by Methyl Radicals

sible to write any rational mechanism in which CO is produced from isopropenol by the attack of radicals (the decomposition of ketene, if it were produced from isopropenol, is negligibly slow at 310°C as calculated from the rate equation given by Williamson¹⁰). Hence, it becomes almost certain that the reactions, (3), (3') and (4), *i.e.*, abstraction of H from the O-H bond, occur to some extent besides that of C-H.

SUMMARY

With azomethane as the source of methyl radicals, induced decomposition of *t*-butanol was studied at 309°C, in which the pressure change and the reaction products were pursued during the reaction period.

Disintegration of butanol proceeds by chain mechanism and the primary products are isobutylene and acetone, being accompanied with the production of OH and CH₃ radicals respectively.

Though the proposed mechanism is somewhat ambiguous and speculative, the primary removal of H atom from the O-H bond of *t*-butanol is likely to occur besides that of C-H to a comparable extent, and also the formation of isopropenol is very probable, which is supposed to be stable in the reactor and to polymerise while it is taken out.

From the material balance it is deduced that methyl radicals are consumed almost exclusively by the reactions of isobutylene, among them the addition of CH₃ to isobutylene followed by the recombination of C₆H₁₁ seems predominant; the greater part of OH is converted again into CH₃ ultimately and only minute amount is lost by the addition to isobutylene or other radicals.

REFERENCES

- (1) Y.Takezaki, *This Bulletin*, **26**, 1 (1951).
- (2) S.Kodama, Y.Takezaki and T.Yamanaka, *J. Chem. Soc., Japan*, **73**, 440 (1952).
- (3) M.K.Phibbs and B.de B.Darwent, *J. Chem. Phys.*, **18**, 495 (1950).
- (4) S.Kodama, Y.Takezaki and J.Yoshida, *J. Chem. Soc., Japan*, **71**, 173 (1950).
- (5) Y.Takezaki and C.Takeuchi, contributed to *J.Chem.Phys.*
- (6) S.Kodama, Y.Takezaki, *J. Chem. Soc., Japan*, **73**, 82 (1952).
- (7) A.F.Trotman-Dickenson and E.W.R.Steacie, *J. Chem. Phys.*, **18**, 1100 (1950); **19**, 171 (1951).
- (8) G.E.K.Branch and M.Calvin, "The Theory of Organic Chemistry" p.289 (1941), PrenticeHall, N.Y.
- (9) K.H.Meyer, *Ber.*, **45**, 2847 (1912).
- (10) "Beilsteins Handbuch d. Org. Chem"., Bd.1, S.435, 4 Aufl. (1918).
- (11) J.B.Conant and A.F.Thompson, *J. Am. Chem.Soc.*, **54**, 4039 (1932).
- (12) K.Noma, *Kobunshi Kagaku* (High Polymer Chem. (Japanese)), **5**, 190 (1948).
- (13) M.P.Esheveskaya, *Refiner* **19** 264 (1940).
- (14) F.F.Rust, F.H.Seubold and W.E.Vaughan, *J. Am. Chem. Soc.*, **70**, 95 (1948).
- (15) H.S.Taylor, and J.O.Smith, *J. Chem. Phys.*, **8**, 543 (1940).
- (16) A.T.Williamson, *J. Am. Chem. Soc.*, **56**, 2216 (1934).