

Title	The Ngandu as Hunters in the Zaire River Basin
Author(s)	TAKEDA, Jun
Citation	African study monographs. Supplementary issue (1996), 23: 1-61
Issue Date	1996-12
URL	http://dx.doi.org/10.14989/68382
Right	
Type	Departmental Bulletin Paper
Textversion	publisher

ABSTRACT	1
INTRODUCTION	1
I. Hunting among the Ngandu	3
II. Hunting Rituals (<i>Bosako</i>)	4
HUNTING ACTIVITIES	6
I. <i>Paho</i> Hunting	6
1. Bow-and-Arrow Hunting	6
(1) <i>Lotongo</i> : Individual bow-and-arrow hunting	7
(2) Bakimano or <i>bakula</i> : Collective bow-and-arrow hunting	9
2. Botai or <i>Mokila</i> : Nets and Net-hunting	11
(1) Botai or <i>mokila</i> : Net-hunting using <i>libanga</i> , <i>bomboloko</i> , and <i>botenga</i> nets	11
(2) <i>Bohonda</i> : Net-hunting for bushpigs	15
(3) <i>Botoke</i> : Monkey hunting	17
3. <i>Paho-ambwa</i> : Hunting with Dogs	18
4. Hunting with the <i>Tombi</i> Shoulder Bag Used by Men	20
5. <i>Losonga</i> : Individual Spear Hunts	20
6. <i>Lingona</i> : Hunting with Guns	20
7. <i>Botoka</i> : Elephant Hunt	21
II. <i>Lilongi</i> or <i>longongo</i> : Trapping	24
1. Spring Traps	24
2. Deadfalls	30
3. Snares	30
4. Spiked Traps	30
5. Bag Nets	33
6. Others	33
THE DISTRIBUTION OF MEAT	34
I. The Distribution of Meat in Collective Bow-and-arrow Hunting, or <i>Bakimano</i>	35
II. The Distribution of Meat in Net-hunting, or <i>Botai</i>	37
III. The Distribution of Meat in <i>Bohonda</i> Net Hunting	39
IV. The Distribution of Meat in <i>Botoke</i> or Monkey Hunting	40
V. The Distribution of Meat in <i>Paho-ambwa</i> Hunting with Dogs	41
VI. The Distribution of Elephant Meat in <i>Elongo</i> Trapping	41
VII. The Distribution of Meat in Trapping in General and in Other Hunting Methods	42
DISCUSSION	44
NOTES	45
ACKNOWLEDGMENTS	47
REFERENCES	48
Appendix 1. Wild animals hunted by the Ngandu	50
Appendix 2. Glossary for the anatomical local terms and related terms used among the Ngandu for fauna	54

THE NGANDU AS HUNTERS IN THE ZAÏRE RIVER BASIN

Jun TAKEDA
Saga University

ABSTRACT This paper provides a detailed description of the hunting activities of the Ngandu, a primarily agricultural people living in the tropical rain forest of the Zaïre River Basin. Four key aspects are presented: types of hunting, hunting rituals, the complex cultural systems surrounding hunting, and the distribution of meat. The extent to which the Ngandu forest people have been and still are concerned with hunting animals that inhabit the forest is also considered. The environmental limitations of tropical rain forests as the context for hunting activities are discussed. It is suggested that such factors have spurred the development of collective hunting, in which unknown numbers of animals are driven to their capture, and have stimulated the development of a variety of effective trapping techniques. Unlike mobile hunter-gatherers, the primarily agricultural Ngandu have to stay in one more or less restricted area to simultaneously maintain their agricultural subsistence activities. It is suggested that the combination of the fact that the Ngandu practice both agricultural and hunting activities within a rain forest environment has largely provided the impetus for the development of a sophisticated hunting technology embedded within a complex cultural system.

Key Words: Bantu-speaking people; Zaïre River Basin; Hunting techniques; Hunting rituals; Distribution of meat; Trapping.

INTRODUCTION

The ecological anthropological field work which is the basis for this report was conducted among the Ngandu, a Bantu people who practice a slash-and-burn agriculture, in Ikela Zone, the state of Equator, the Republic of Zaïre in central Africa. The Ngandu are members of the Mongo peoples who are widely dispersed over the tropical rain forests of the Zaïre Basin (Murdock, 1959). The field work was carried out in two sessions. The first from September 1975 to February 1976, and the second for about five months, from August to December 1977 (Takeda, 1990).

The Ngandu are both agriculturalists and hunters. They clear primary forests to grow cassava as their staple subsistence crop, and also use the natural resources of the rain forest environment as an indispensable source of food. The tropical rain forest supports a wide variety of plant and animal life, and the Ngandu have developed sophisticated subsistence activities to take advantage of this fact.

In this paper I focus on the ecological anthropological aspects of hunting, and provide a detailed description of types of hunting activity, hunting technology, and the complex cultural practices which surround all hunting activities including the distribution of meat. I then proceed to discuss the reasons why such practices might have developed. Refer to Takeda (1990) and Kimura (1991) for details of subsistence activities of the Ngandu.

The Ngandu live in three types of hamlets: *behecha* or permanent forest villages with cassava fields, *kumbo* or temporary hunting hamlets, and *boola*, which are newer

villages established along the highways and secondary roads that were developed under Belgian colonial administration in the 1930s and 1950s. Both *behecha* and *boola* villages are typically composed of extended family groups belonging to the same lineage (*boola* or *losombo*; Takeda, 1991). *Kumbo* hamlets are exclusively for hunting or fishing and are composed of members of one family or, at most, several families, who construct simple temporary dwellings (*lilombe*) using the leaves of the *bombongo* tree (*Gilbertiodendron dewevrei*, Caesalpiniaceae)⁽⁰⁾ for walls and roofs. They live in these dwellings between two to five months. While Ngandu hunters are allowed to hunt in different administrative zones they are not allowed to have fields there, so when hunting they eat cassava (*Manihot esculenta*, Euphorbiaceae) which their women either bring from their *boola* along the road, or buy and barter, from nearby hamlets that do have fields. Such an act is called *beengo*⁽¹⁾.

The Zaïre Basin is remarkably flat. The survey area is about 350 meters above sea level and lies directly on the equator (Fig. 1). There are no clearly defined wet and dry seasons, but the year can be divided into a comparatively dry period *elanga* (January to June) and a wetter period *eula* (July to December). The beginning of the rainy season, from July to September, called *luuma*, is a season when edible insect larvae appear in abundance and the forest is at its richest. According to weather records for Djolu, which is the center of Djolu Zone and located approximately 90 km north of the area of investigation, from the years 1960 to 1967, the average annual rainfall was 2,052 mm and the average annual temperature was 24.3°C (Longman & Jenik, 1974).

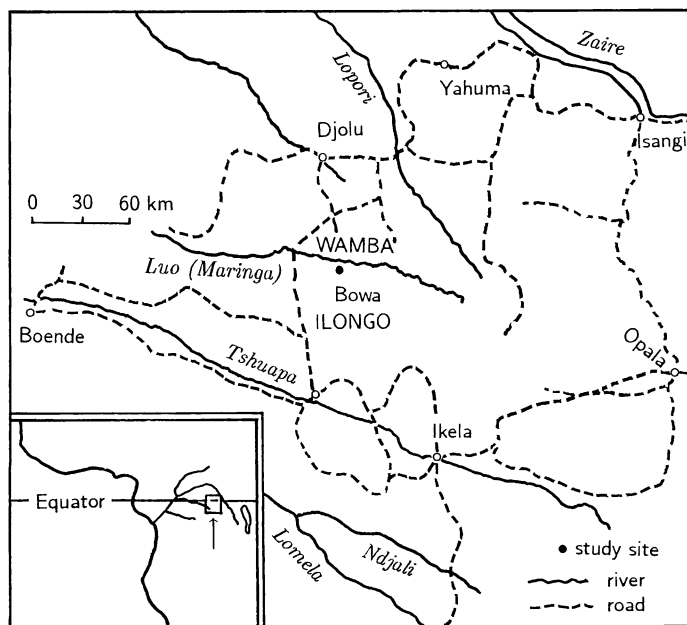

Fig. 1. The study site.

Vegetation in the survey area consists of primary forest (tropical rain forest), secondary forest growth, swamp forest, and cleared fields. The composition of the primary forest is complex, but Caesalpiniaceae trees which include *bofili* (*Scorodophloeus zenkeri*), *botuna* (*Cynometra hankei*) and *bombongo* trees, are plentiful. The Vitaceae and Apocynaceae vines are also common. Secondary forest growth over abandoned fields is recognized by the abundance of the fast-growing *bochumbe* (*Musanga cecropioides*, Moraceae). Swamp forest has developed along the rivers that run like a network through the forest. The swamp forest is composed of *bosenge* (*Uapaca heudelotii*, Euphorbiaceae) and *waaka* (*Guibourtia demeusei*, Caesalpinaceae), as well as *mpeto* (*Sclerosperma mannii*) and *bolilo* (*Raphia* sp.) of the Palmae family.

I augmented the data collected through participant observation during my stay in the survey area with data I obtained from the Ngandu in the Lingala language. The names of plants and animals used in this work, and other names in general, are given in the singular form in the Ngandu language, a language which has some aspects in common with the Mongo language. Where the language undergoes irregular changes between singular and plural in the text, I have included both.

I. Hunting among the Ngandu

The Ngandu have elaborated two basic types of hunting: direct immediate seizure and trapping. Direct immediate seizure of specific animals that have been sighted is called *paho*.⁽²⁾ Bows and arrows, spears, and nets are the primary implements in *paho*. Trapping, called *lilongi* or *longongo*, is the setting of traps which must be left out for a certain length of time before any animals are caught.

Hunting is both an individual and collective activity. Individual hunting includes *lotongo* (usually one hunter, occasionally up to three) hunting with spears or bows and arrows without the use of dogs. The Ngandu very rarely hunt with guns. Collective hunting involves groups of two or three up to ten-odd participants. Types of collective hunting include *paho-ambwa* (in which dogs are used), *botai* (hunting with nets), collective bow-and-arrow hunting called either *bakimano* or *bakula*, and *botoke* (monkey hunting). Sorcerer specialists known as *nkanga*, who have knowledge of traditional hunting techniques and secret rituals, take part in *botai* net hunting, the more traditional *bohonda* net-hunting,⁽³⁾ individual bow-and-arrow hunting, collective bow-and-arrow hunting, elephant hunts, and trapping. The *nkanga* is usually the leader of the hunt.

The Ngandu have developed a wide variety of traps for *lilongi* trapping, which are designed to take advantage of the habits of the specific animal to be trapped. Trapping is practised in every type of environment from the primary forests, secondary forests and swamp forests to the vicinity of cultivated fields. When the hunters go around to check the traps, they repair them and change their location, so the traps are set within an area that is a one- to two-hour walk from the village along animal trails and near watering holes. *Elongo*, or large elephant traps, are set by two helpers under the instruction of a *nkangongala* who has mastered the magic and techniques (*bongala*) associated with elephant hunting. When this technique fails, elephants are hunted individually.

It often happens that hamlets without fields, *kumbo*, (built by those who operate

out of *behecha* hamlets with fields) or *boola* hamlets (built along the road as a base and used solely for mounting hunts), have developed into *behecha* and become long-term residences. There are three kinds of *kumbo* hunting camps: *isowa*, *ihombo*, and *lihana*. *Isowa* are small, comprised of one to four men who form a hunting party mostly for individual bow-and-arrow hunting and trapping. *Ihombo* hunting camps are larger with groups of at least seven to eight men who stay together for three to four months and mount collective bow-and-arrow hunts and hunts with nets. *Lihano* camps consist of a *nkangongola* hunting specialist and two assistants (*ekoho*) who spend two to four months living in the forest setting 10–20 *elongo* elephant traps.

II. Hunting Rituals (*Bosako*)

If a man agrees to go and live in a *kumbo* hunting camp to hunt with others, but then cannot go as promised, the hunting party proceeds without him. If they fail to get an animal after a week or two, they return to the village and urge the man who could not go with them, to go. This is sometimes also done when the hunting party returns to the *boola* village to replenish its supply of cassava through *beengo* (see also Note (1)). If the man agrees there is no difficulty. However, if he still cannot go with the hunters, he takes a leaf from a banana tree and spits into it several times while rubbing it between his palms. The hunting party takes this spit wrapped in leaves (*linuka*) back with them to their *kumbo*, where they fuel a fire with it when they arrive.

The Ngandu believe that ancestral spirits of the forest, *bolimo* are responsible for providing game. Therefore, they practice a number of rituals or *bosako* in order to ensure good hunting. Prayers are offered to the spirits (*bolimo*) on small ledges (*ekoli*), or small models of houses (*iyoma*) holding votive offerings which are especially constructed in remote places in the forest for this purpose. Hunters may also consult a *nkangosako*, (the *nkanga* of a man or woman who has gone through the *bosako*) to determine what offerings they should make to which ancestral spirits in order to propitiate the *bolimo* spirits (Takeda, 1991).

Liyando is a type of *bosako* ritual conducted both for collective hunting and for individual hunting in which various portions of meat are burnt and offered to the *bolimo* by hanging the carcass of a sacrificial animal on the ancestor's grave. When sacrificing, *buusa*⁽⁴⁾ (see also Appendix 2), *lihimo* (the portion which includes the skin of the belly and the meat adhering thereto, but excludes the rib section) and the kidneys (*ilondola*, plural; *tolondola*) are burnt together on a fire, a little is eaten with the fingers, and the offering is then made. For offerings to female *bolimo* spirits, a hen is beheaded and the blood sprinkled on the grave (*ngelo*) of a particular ancestor, after which the carcass is hung from a pole thrust into the ancestor's grave. The same is done in the case of a male spirit but a cock is used instead. If animals other than poultry are used, the animal is not necessarily beheaded, but the complete carcass is hung. Offerings made at the grave and on the *ekoli* ledges include honey, termites, bananas, liquor, wild fruits and nuts that have been gathered. If, after making the offering, a hunt is successful, the spirits are thought to have been satisfied with the offerings. If the hunt continues to be unsuccessful the hunters once again consult the *nkangosako*, present different offerings, and then continue the hunt.

The *lokotelo* ritual is carried out to ensure successful trapping. The wife slashes

the back of the hunter's right wrist in two or three places with a *lokengo* (the traditional Ngandu knife which is long and thin, and used also for dental work, bloodletting, and tattooing). She gets the hunter's blood, and then wipes the wound with the leaf and stem of the *lilanga* herb (*Crinum jagus*), one of the cultivated plants (*bohusi*). For the purpose of successful hunting, a *nkangalikula* or hunting specialist for the rites associated with individual *lotongo* bow and arrow hunting, may also use a *lokengo* knife to slash the skin on the top of his own right hand (i.e., the hand that pulls the string of the bow) from above the tendon to the base of the middle finger at four places perpendicular to the tendon in order to get blood. Usually he has his wife inflict these wounds, instead of inflicting them himself. *Palwa* (singular; *lohalwa*), or shavings from the bark of the *bosole* (*Baphia laurifolia*), together with *longola* (*Rothmannia* sp.), are rubbed into the wounds.

In the *syunu-a-likula* rituals the hunter prays for success in bow-and-arrow hunting. In one of these rites the hunter places the scrapings of the inner side of the bark of the *bokungu* tree (*Piptadeniastrum africanum*)⁽⁵⁾ in *lokokolo* (*Sarcophyllum schweinfurthianum*, Marantaceae) leaves and squeezes out the juice contained in the sap. He then pours the juice into the hollow at the base of the arrowhead (*bolongo*) (into which the tip of the shaft of the arrow is usually inserted) and onto the tip of the shaft (*iende*). In another of the *syunu-a-likula* rites called *bosako-lokambo*, the hunter forms his left hand into a fist and places a leaf over the circular space formed by his thumb and forefinger. He then strikes the palm of his right hand repeatedly⁽⁶⁾ and whispers the name of the animal he wishes to catch in the forest.

There is a special *bosako* ritual, practised to ensure the successful trapping of an elephant in an *elongo* elephant trap, which is orchestrated by the *nkangongala* specialists but the people, women as well as men, have a role to play. In this ritual, a single *lokongo* (*Megaphrynium macrostachyum*) leaf is spread out on the ground. Then branches of *iyamba* shrubs (*Albizia gummifera*) and *loleholeho-isongo* shrubs (*Agelaea* sp.), which have been stripped of their leaves, are placed on the leaf, and water is poured over it.

Women, ritually dressed, go first. They crouch before the leaf, one at a time whispering secret women's words. After the women the men go one by one. They rub their tongues with the cut and slightly split tip of a sugarcane or pineapple leaf blade to release blood, which they then spit into the leaf. The *nkangongala* goes last and wraps up the leaf and its contents. The men then go and sit inside the *losombo* (a structure built separately from their residences which doubles as a gossip hall and/or a workshop), and the women stand outside. Together, they raise their hands as if in celebration of a victory and let out a loud cry. The men take the wrapped *lokongo* leaf and its contents with them when they go to set the *elongo* elephant trap. After the *elongo* has been set, they return to the *losombo* men's house where the *nkangongala* leads them in songs about the *bongala* elephant-trapping rituals with everyone beating two wooden clappers (*likese*). These *likese* clappers will also be used ritually when an elephant, caught in the *elongo* trap, is to be slaughtered.

In the *luuma* ritual the Ngandu go into the forest with gourds of *baana-isongo* (a liquor made from sugarcane) and a kind of steel musical instrument (*elonja*)⁽⁷⁾ in order to propitiate the *bolimo* spirits. They leave the drink as an offering on the *ekoli* shelf, and play the *elonja* but do not sing any songs. If the site is a distant one, only one man will carry out the ritual, but when the *ekoli* shelf is located nearby

the Ngandu turn out in force. When assembled, they raise their voices in a loud cry like in the ritual for the *elongo* elephant trap, described above.

HUNTING ACTIVITIES

I. *Paho* Hunting

1. Bow-and-Arrow Hunting

A *nkanga* specialist who has knowledge of the mysteries of hunting is always present at bow-and-arrow hunting. Sometimes the same person will combine the roles of the *nkanga-likula* of individual bow-and-arrow hunting and the *nkanga-lusala* of collective bow-and-arrow hunting. In bow-and-arrow hunting certain people famed for their prowess may be called *mbengi*, but these individuals are not necessarily *nkanga*.

Three types of bows are used in *paho* bow-and-arrow hunting. The *mongangu-beelele* bow, about one meter long, is made from *lihindo* (*Eremospatha hookeri*), a palm vine, with split *longoli*, and another palm vine (*E. haullevilleona*), for the string. Arrows or *boolele* used with this bow include *boolele-ba-lolengo* [a poisoned arrow in which the arrow tip (*likenyu*) is coated with poison (*lokili*)⁽⁸⁾ and inserted into the shaft of the arrow (*botamba*)], and *boolele-bisanga*, in which the midrib of the oil palm (*Elaeis guineensis*, Palmae) is split and paired to a single slender shaft with its tip sharpened to a point. *Boolele* arrows not tipped with poison are used by children for practice in hitting small mammals and birds. Poison-tipped arrows are used by adults for shooting monkeys in trees, usually with the realization that such arrows will not be retrieved. The shafts of *boolele* arrows are made from *bokau*, a palm (*Ancistrophyllum secundiflorum*). They have a vertical slit near the notch for the arrow, into which are inserted either two leaves of matching size or a single bird feather, to form a sort of weather vane (*lusala*) which resembles the horizontal tail of a plane.

Poison-tipped *boolele* arrows are always carried in a cylindrical case which covers the tips, made from the bark of the *bofumbo* tree (*Grewia pinnatifida*) or the split stem of the *bokau* palm or *bokombe* tree (*Haumania liebrechtsiana*).

Another small bow which resembles the *mongangu-boolele*, is the *bota* bow, made from the *bokenju* tree (*Aidia congolana*), which is used to shoot steel-tipped *likyasa* and *lokati* arrows. Both *likyasa* arrows [without backward-slanting barbs (*litama*)] and *lokati* arrows (with one backward-slanting barb) have the arrowhead thrust tightly into the arrow shaft, and so look very much like a spear. *Bota* bows are also used with poison-tipped arrows, making them fully capable of killing bushpigs and yellow-backed duikers.

The bow most commonly used by the Ngandu today is not a traditional bow but is influenced by the Bosaka people to their southwest, with steel-tipped arrows (*likula*) not coated with poison. This combination is used both for individual hunting and collective hunting. Unlike the two more traditional bows, which are slim, short, and light, the introduced *mongangu* bow is nearly two meters long, and is rigid. The *litsulambwa* tree of the Apocynaceae (*Pleiocarpa pycnantha*) called *eloho* in the Mongo language, is usually selected for this bow. In addition to *litsulambwa* tree,

woods such as *boilu* tree (unidentified) and *bosefe* tree (*Garcinia punctata*) are also used for the bow.

The bark is scraped off and the ends are pared. The skin of the mona monkey (*mbeka*: *Cercopithecus mona*) is often wound around the central grip to keep the hand from sliding. Two red feathers from the green turaco (*loka*; *Tauraco persa*) are sometimes inserted in the space between the monkey pelt and the bow as a decoration (*lohenga*, plural; *penga*). Fibers from the bast of the tree-like vine *lokosa* (*Manniophyton fulvum*)⁽⁹⁾ of the Euphorbiaceae family are twisted together to make the bowstring. One end of the string is left tied to one end of the bow. When the bow is to be used, the end with the string is placed on the ground; the other end is taken in both hands and bent inward, with the right foot placed on the middle of the bow. The free end of the string is then tied to the bow, thus stringing it.

There are 16 types of steel-tipped arrows (*likula*), and these are classified according to the number of barbs on the arrowhead, the presence or absence of notches on the base of the arrowhead, and the length. The single-barbed *lusanga*, *lusenge*, and *lohondi* types are favored for their effectiveness against animals. Traditionally steel-tipped arrows were produced by a blacksmith (*nkangosanda*), but now many hunters are proficient at making and repairing their own arrows. Construction of the *likula* arrows is as follows: the shaft is made of *bolafa* (*Salacia alata*), and the arrowhead and shaft are tied together with the *lokosa* string. This string is longer than required so the excess length can be threaded or stuffed between the back of the arrowhead (*bolongo*) and the tip of the arrow shaft. Unlike the *likyasa* and *lokati* arrowheads which are used with the *bota* bow (see above), the arrowhead of the *likula* arrows is not thrust tightly into the tip of the arrow shaft, so it is possible for the arrowhead to fall off the *likula* arrow. Usually, hunters keep the joint between the arrowhead and shaft firm by winding fresh leaves around the tip of the shaft as a cushion (*jy-ongo*). Any kind of leaves may be used but *londende-isongo* shrub (*Hibiscus* sp.) and *bondendende* shrub (*Cola bruneeli*) leaves are used most common. The Ngandu use the wing or tail feathers of the *bongonde*, a species of hornbill (*yaata*), or the wing feathers of birds such as *eike*, *bowa*, *punungoli*, and *pwa* or the female crested Guinea fowl (*lokanga*) and Congo peafowl (*litundu*) to feather their *likula* arrows. Some people also use duck feathers. The feathers are cut in half along the quill and attached to the cylindrical shaft in three evenly spaced places by coating the area with melted glue (*ilaka*) from the *bolongo* tree (*Symphonia globulifera*). In contrast to the feathers of the poison-tipped *bootele* arrow which are arranged in a kind of horizontal plane, the feathers of the *likula* arrow, when viewed in cross-section, are arranged at regular intervals of 120°. For added strength the feathers are then tied in place with *lokosa* string.

A hunter will carry at least two or three *likula* arrows with him when going hunting, and he will carry these arrows in his hands together with the bow; there is no quiver (*poho*) for *likula* arrows.

(1) *Lotongo*: Individual bow-and-arrow hunting

Lotongo refers to bow-and-arrow hunting by one individual without a dog, but the term can also apply to a group of two or three hunters without a dog.

A *lotongo* hunt begins with either the direct sighting of an animal, the discovery of traces such as faeces, footprints, etc., or by picking up the sounds of game animals.

Sometimes, sounds made by other birds and animals in response to the presence of game animals will initiate a hunt. For example, the hunters may hear the *liseko*, or the alarm calls, made by *poo* (small rodent species) and small flocking birds in response to the presence of forest antelopes, terrestrial tortoises *eulu* (*Kinixys erosa*) or snakes, and follow these calls to their source. If game animals cannot be found, the hunters imitate the game's calls in order to draw the animals closer, by holding their nose closed with their fingers and emitting a high-pitched cry (*lomao*).

This attracts two classes of game: *nyaama-kolomo* (a general term for one of the major animal classifications of the Ngandu, indicating a short-legged carnivore that turns vicious when caught, like the mongoose, golden cat, genet, and civet) and *nyaama-lokolo* (the general term for long-legged, docile antelopes like blue duiker, Peter's duiker, bay duiker, and yellow-backed duiker, as well as the bushpig and the African crowned eagle (*punungoli*: *Stephanoaetus coronatus*). By pursing their lips and holding their hands to their mouths, hunters emit a short *bomwete* burst of sound, resembling a mouse.

They do this in order to call the small rodent, *poo*, and, among the *nyaama-kolomo*, the mongoose, golden cat, genet, and civet. *Bomwete* is so effective that *bokoma* squirrels are brought so close to the hunter that they must be pushed away before they can be shot with arrows. The *lomao* and *bomwete* cries are performed both by individuals on a *lotongo* hunt, and by any Ngandu who can produce these imitations during collective bow-and-arrow hunting.

To make a sound which attracts monkeys (*nkema*: especially mona monkey and black mangabey) the Ngandu use an instrument called a *boswe* which must be prepared beforehand and brought along on the hunt. This attraction is especially good for the mona monkey and black mangabey. It is made by finely cutting and splitting a leaf of the *bokau* palm along the midrib, and folding the leaf in half. A single small cutting of the *lohető* palm leaf (plural; *mpeto*: *Sclerosperma mannii*, Palmae) is then inserted into the folded leaf to function as a vibrator. When the hunt begins, this implement is held with the right hand, placed against the mouth, and blown into to produce a whizzing sound. While noise is made with the *boswe*, a leafed branch (*lunjya*) is whirled through the air or a stick is rubbed against the ground, thus attracting the monkeys. Meanwhile, if this hunt is accompanied by other hunters, hunters hidden in the trees kill the monkeys with their bows and arrows when the monkeys come to investigate the sound. The Ngandu, who traditionally hunted monkeys with poison-tipped *boolele* arrow until they acquired the *likula* arrow from the Bosaka people, used the *boswe* often in the past. However, the introduction of the *likula* arrow has led to the decline of the *boswe* cry.

In order to become a *nkanga-likula* or specialist for the rites associated with individual *lotongo* bow and arrow hunting, one must make an initial payment to a teacher of one pot (*lidasu*) and two plates (*sahani*). The teacher is a publically recognized *nkanga-likula* who has already acquired knowledge of these rites. The second payment consists of one *elembe*-type spear (see Note (14)), one tail feather from an *ekongo* parrot, two *likula* arrows, and one horn (*liseke*) of the bongo (Takeda, 1991). The teacher then pours three liquids in succession into the eyes of the pupil, an act called *boloi*.

The first liquid consists of a little water poured into the pith of the African ginger (*bosomboko*: *Aframomum* sp.), the second, of a little water poured over the

shavings of the root of the *lolohili* tree (*Afrostryax kamerunensis*)⁽¹⁰⁾ and the third, a liquid poured over torn and rubbed pieces of grass called *longengetela* (*Axonopus compressus*). Then, the pupil must drink a potion made by pounding the bark of the *bolanga* (*Bridelia atroviridis*) with about 20 African ginger seeds (*londake*; plural, *ndake*), an act called *likemo*. When a pupil who has carried out both the *boloi* and *likemo* rites fails to catch any game, he must treat his arrows. He makes a potion by mixing the charcoal made by burning the pith from the stem of the *londendeisongo* with mesocarp oil of oil palms. He must rub this on the string (*bosinga*) made from the *lokosa* herb (*Manniophyton fulvum*)⁽⁹⁾ that fastens the arrowhead to the shaft of his arrows.

The role of the hunting specialist is culturally elaborated by various taboos. Women cannot eat the *liho* squirrel caught by the *nkanga-likula* specialist, nor can men or women without children eat the meat of the belly (*lihimo*; see also Appendix 2) of the animals he has caught. The *nkanga-likula* is forbidden to take cassava by thrusting his right hand into the mortar in which women have pounded cassava. The *nkanga-likula*, like the *nkanga-lusala* (the *nkanga* specialist for the *bakimano* collective bow-and-arrow hunt), does not eat the meat of the giant rat (*botomba*); but unlike the *nkanga-lusala*, the *nkanga-likula* does not take the *lusala* (a sitatunga horn, *liseke*, containing *boote*, or hunting medicine) with him when he goes on a hunt.

(2) *Bakimano* or *bakula*: Collective bow-and-arrow hunting

Bakimano is a collective hunting without dogs in which hunters with bows and arrows (*boto-ba-lalo*), two beaters (*imbombo* or *imbombo-la-likula*), and *bototai* or people who carry a kind of net called either *botenga* or *bomboloko*, work together. A minimum of six to seven men are necessary to conduct such a hunt but the group may sometimes number up to twenty. Beaters are usually older men, men who are not good archers, or boys. Occasionally, girls may perform the role of beaters when the hunting party is short of hands.

The *nkanga* specialist of the collective bow-and-arrow hunt (the *nkanga-lusala*) is usually the one who initiates the hunt. The initiator of the hunt is called *bochinja*, so the *nkanga* is also the *bochinja* in most of the *bakimano* hunting. He informs those in the nearby area of the hunt a day or several days beforehand by means of traditional drums (*lokule*)⁽¹¹⁾ and elephant tusk flutes (*bopati*), or by word of mouth. On the day of the hunt the hunting party gathers at a meeting place in the forest (*eombokulu*) to await the arrival of all participants. During this time each hunter strings his bow and tests his arrows. The *nkanga* instructs each one as to his position and course, placing the participants in a single line on either side of himself at intervals of about 10–20 meters. The beaters are positioned at both ends of the line and the line advances at the beaters' voice signal. The beaters, who have round bundles of the *ikokolu* herb in their hands, proceed at a pace of about two kilometers per hour while shouting and beating the trunks of trees they encounter in their path. Animals frightened by the shouts and sounds of the beaters are driven inward toward the archers. Those with nets follow behind the line. An archer who sights an animal informs the others by playing either a hand flute (*ihonge*) or a mouth flute (*iyoli*; plural, *tolî*; see Note (11)). The other archers then form a circle (*elonga*)⁽¹²⁾ around the animal while the net handlers who are following behind spread their nets ready

to catch the animal should it try to escape through the rear of the circle. Whether or not the arrows kill the animal, afterwards each person again assumes his station in the line and they proceed in the same way once more.

If the animal is brought down it is taken to the beaters, where it is placed in a shoulder bag called a *tombi* and carried along. The *tombi* is the traditional shoulder bag of the Ngandu male, which is made by looping (MacKenzie, 1991) string which has been made by twisting together the fibers from the *lokosa* herb (see also Notes (9) and (15)). From the start of the hunt to the finish, the archers carry nothing but their bows and arrows. Usually, game is driven towards a river and the hunt ends there (such a place is called *londo*). Not far from the *londo*, at a resting place, the hunters will slaughter the game and divide the meat; such a place is called *eombo-likolo*.

The hunt is continued without interruption for the entire distance from the starting point *eombo-kulu* to the *londo*. It usually takes about six hours to move out of the forest, slaughter and divide the kill, and return to the village.

During the hunt, participants communicate with each other through use of the *iyoli* whistle and/or by sign language, although sometimes they speak in whispers as well. Unlike in net-hunting, the game in these hunts sometimes escapes because the group forms a single line with men spaced at intervals rather than forming a circle. Nevertheless, such hunts are frequent because no heavy nets need to be carried along.

The *nkanga*, who takes the central position in the line, is flanked (facing forward) on the right (*bendobilome*) and left (*ebendobiyali*) ends of the line by the beaters, with several archers in between. The archers on either side of the *nkanga* are called *boya*; those positioned next to the *boya* are called *sako*. The archers next to the beaters are called *ikocha*. The *ikocha* have the task of keeping the line straight and abreast of the beaters, neither straying ahead nor lagging behind. In between the *ikocha* and the *sako* are several archers collectively called *totopiho*. Behind the line come the *bototai* who have nets across their shoulders and who carry either spears or short swords.

Nkanga who have gone through a collective *bakimano* hunt are called *nkanga-lusala*. In order to become a *nkanga-lusala*, one must make an initial payment (*lunelo*; plural, *baunelo*) to a teacher. Such a *lunelo* payment consists of one *poo* spear [this is an elegant spear sheathed in copper which also forms part of the bridewealth (*ngando* or *yelo*) that the groom's relatives give to the bride's relatives at marriage], one *bolombolombo* [this is the largest copper band (*baango*) which is also used to make up *ngando* bridewealth, in memorial services for the dead, and for the *bongala*], 30 makuta⁽¹³⁾ in cash, five short swords, two cups, three plates, two *bololi* (a type of string women wear around the waist), and one spoon (Takeda, 1991).

This initial payment must usually be followed with a second payment of another *poo* spear,⁽¹⁴⁾ one short sword, and a single *lusanga* arrow which has one backward-slanting barb on its arrowhead and a notch (*latu*) extending all the way to the tip of the arrowhead. After this second installment, a third payment (*bosambo*) is made three months later. It consists of the following: one *bolombolombo* copper band, three short swords which are also used as part of the *ngando* bridewealth, one or two spears, three zaïre; see also Note (13)) in cash, one *iïwu* (a bed mat), one *buhongola* (a woman's backpack frame used in daily life for carrying large quantities

of such things as firewood, cassava, animals, etc.), one plate, one bottle, and one cup.

After a pupil pays the *lunelo* to the teacher, he then accompanies his teacher on a *bakimano* hunt. His first kill is called *botono* and women cannot eat any of it. The men bring cooked cassava and gather together, where they eat the *botono*. The leftover meat is either consigned to the flames or given to the dogs, but in any case it must be entirely consumed on the day it is killed and not left until the next day. If no game is taken that day, the pupil must not eat. He continues the hunt with his teacher the next day.

The game the pupil takes on the second hunt with his teacher is called *lohanjahanja*. Women are allowed to eat this second kill. With a successful *lohanjahanja* the pupil is recognized by his teacher as a full-fledged *nkanga* in his own right. When a *nkanga* leads a collective bow-and-arrow hunt, he either enters the forest with the *lusala* (a *liseke* horn of bongo or sitatunga containing the medicine handed down to him by his teacher) over his shoulder, or leaves it outside his house, hanging from the *ikako*, a hanger made from a Y-shaped *elei* (*Napoleonaea imperialis*) bough with its bark removed and with one end thrust securely into the ground. First, the *lusala* horn is packed with earth from an ancestral grave and shavings (*palwa*) from the bark of the *bolonda* tree (*Xylopia chrysophylla*). Chicken or porcupine blood is then poured into the *lusala* medicine horn. The opening of the horn is then stuffed with bird feathers and then a branch of the *iyele* shrub (*Ocimum bacilicum*), a cultivated plant (*bohushi*) with a distinct smell, is thrust into the opening.

Bird feathers—except for those of the *lokulakoko* birds—can be used for this purpose. It is not necessary to use feathers from the same bird; even chicken feathers can be used. Sometimes different things are stuffed inside the horn such as uprooted *lolohili*, *bokolembé* (*Staudia stipitata*) or *botolambengela* (*Cola griseiflora*) shrubs; an *iyele* branch may be used to fill the opening.

2. *Botai* or *Mokila*: Nets and Net-hunting

The Ngandu use nets made by spinning fibers from the bast of the *lokosa* herb and then looping them together. The word *botai* is the general term for nets and net-hunting, but it usually refers to three types of nets and net-hunting, excluding the large mesh traditional *bohonda* net-hunting for bushpigs. The three *botai* nets are of different mesh sizes and, in order from the largest to the smallest, are called *libanga*, *bomboloko*, and *botenga*. Each is designed to catch different types of animals. Net-hunting involves bringing nets together to form a circular enclosure in which the game animals are trapped. Among the Ngandu, nets may also form part of the *lisongo* bride's dowry (Takeda, 1991). The entire process of manufacturing the *botai* nets, from twisting together the *lokosa* fibers to making the net itself, is done by men; it is a difficult hunting implement to make.

(1) *Botai* or *mokila*: Net-hunting using *libanga*, *bomboloko*, and *botenga* nets

The mesh of the *libanga* net is about ten centimeters in diameter and is used for catching medium-sized antelope. The *bomboloko* net is used to snare small and medium-sized antelope. *Botenga* the net with the finest mesh, is used for catching such *nyaama-kolomo* as mongoose, porcupine, and genet. When fine-meshed nets

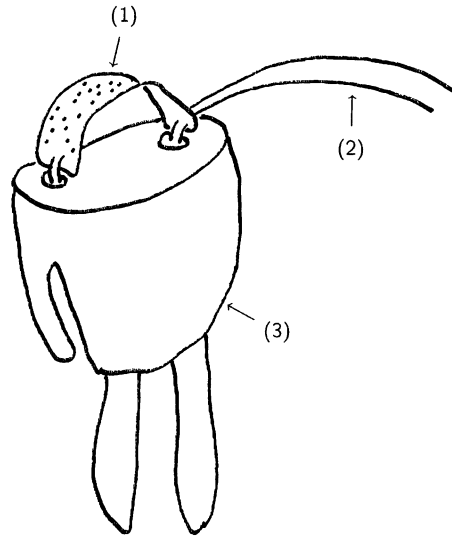

Fig. 2. *Eeleho* or a wooden bell worn around the dogs' neck.

- (1) *loho* (plural; *njoho*) which is worn around the dog's neck. It is usually made of bongo skin, but the skin of Peter's duiker is not used for this purpose, because it is too easily cracked or broken.
- (2) two *besinga* (singular; *bosinga*): strings made of *lokosa* (see the text and Note (9)) which become tightly fastened after loosening the *loho* and letting the dog's head pass through.
- (3) *eeleho*: the main body of the hunting device, which is made of the *busulu* tree (*Pterocarpus soyauxii*). The hollowed out wood vibrates like a resonator. Two slender sticks, made of the *boilu* tree and inserted between the slit, bang together to make loud sounds as the dog runs in the forest. The Bambuti Pygmies also use a similar device, with two or three sticks, for the same purpose (Harako, 1977).

like the *botenga* and the *bomboloko* are used on collective bow-and-arrow hunts such as the *paho-ambwa* and the *bakimano*, the carriers position themselves near each other so that the nets can be effectively combined. Dogs wearing wooden bells (*eeleho*, Fig. 2) around their necks are also used to drive game into the nets.

Net-hunting is usually conducted in groups ranging from five or six people to 10–15 people. The practice of residing for three or four months at a *kumbo* hunting hut for the sole purpose of conducting a *botai* is called *ihombo*. The *nkanga* for the *botai* is called a *nkangotai*. He alone conducts the rites for successful hunting and decides on placement of the nets and positioning of the hunters. When he goes on a *botai*, he hangs a *tombiotai*⁽¹⁵⁾ net bag on the *ikako* hanger (made from the Y-shaped bough built near his house) and takes along two pelt bundles (*likunda*) and horn flutes. One bundle, made from the skin of the *simba* genet, contains tree leaves (the kind of tree does not matter), combined with drops of water which have fallen from trees (*etoitoi*). These leaves, together with *bokasu* leaves (*Rhaphiostylis beninensis*), are dried, crumbled by hand, and mixed with salt (*euki*)⁽¹⁶⁾ made in the traditional way by burning plants to form a mixture called *losondo*.

In former times this mixture was eaten before setting out on a journey as a means of warding off danger along the way (*likoko*) (see also Note (15); Takeda, 1991). The other bundle, made from the skin of the *bolende* genet, contains a mixture of *boyenga-puusa* (*Canavalia ensiformis*) bark which, together with *lilongo* (*Garcinia pynaertii*) bark, is dried and mixed with red paint (*ngola*).

In addition to the *pongo* flute made from *liseke* bongo or sitatunga horns, the *nkanga* also carries an *ilenge*, a flute made from the *nsia* horn of the Peter's duiker or yellow-backed duiker, for the purpose of summoning people, to signal the end of the hunt, and to signal when an animal has been caught in the *botai* net. If it rains while the hunting party is on a *botai*, someone who has remained in the village must take the *tombiotai* shoulder bag which the *nkangotai* specialist left hanging on the *ikako* hanger, and bring it inside the house. The ideology is that the *tombiotai* must not be touched by any women except the specialist's wife. If it has not rained, on his return from the hunt the *nkangotai* or his wife brings the *tombiotai* into the house. All the hunters start from the *eombo* starting point at the sound of the *pongo* flute played by the *nkanga*, and they advance as one towards the *boya* starting point (this action is called *bindi-motai*) where they will set their nets. Members of the group who have started late, or who have strayed from the course also use the sound of the *nkanga*'s flute to guide them to the *boya* starting point.

The *nkanga* sits inside the nets with a branch or branches broken from trees (*lunjya*) in his hands. The men on the left and the right of the *nkanga* set the nets. The *boya* archers on either side of the specialist spreads their nets first, followed by the *sako* next in line. Several more nets (*euna*) are added together until they reach the *liko* hunter whose role is to stretch the end of nets on each side. The hunters use standing poles to support the junctions of the separate smaller nets. Although there is an opening in the completed net between the *liko* hunters on the left and right ends, this almost circular enclosure formed by the *botai* net is also called *elonga*. It is forbidden even to whisper until the net has been spread all the way to the *liko* hunter; communication between members of the hunting party is entirely through sign language. The *nkanga* sits before the starting point from which the net was spread, while those who have brought the nets (*boto-tai*) stand before their own nets with bows and arrows or short swords and spears, waiting for any animals that may be driven into their nets. Those who have brought dogs (such people are called *boto-ambwa*) carry bows and arrows or spears, and they bring their dogs from the *elonga* opening inside the net to drive the animals caught therein (see Fig. 2). The *liko* hunter stationed near the *elonga* carry spears, but, like the *imbombo* (beaters) of the collective bow-and-arrow hunt, they beat trees and shout in order to prevent the animals from escaping through the *elonga*. *Lichindo* or *ichinda* (beaters) who are usually children, are positioned inside the *elonga* in order to try to drive game into their fathers' nets. They hide themselves behind trees and wait for game to pass close by, whereupon they shout and beat the earth with sticks in order to drive the game into the nets by their menacing action. It is believed that bushpigs do not attack the *lichindo*. Children from about the age of eight or nine up to the age of about 15 can perform this task.

Botai usually involves forming and reforming the *elonga* six times a day. The first formation of the *elonga* is called *elongakulu* or just *bokulu*, the fifth is called *sakeliya*, and the sixth and last, *liyako*, but the third and fourth have no special name.

If no game has been taken after two or three formations of the *elonga*, the *nkangotai*, at the *embo* starting point, puts the *losondo* mixture from the *simba* genet bundle into his mouth and then spits it out, whereupon the hunt is resumed. If animals are then caught, the other *bolende* genet bundle remains unopened. If no animals are taken after the fifth formation or *sakeliya*, then the *bolende* bag is opened and the *boote* (hunting medicine) it contains is smeared on the net. After the sixth and final *liyako* the party retires to the *embo* starting point to slaughter the kill. Each animal belongs to the hunter in whose net it was caught. First these owners must distribute the culturally designated portions of the meat to the *nkanga* hunt leader and other hunters who helped significantly. These portions, which are distributed first are called *eyali*, and are discussed in detail below. The owners may then share the remainder with any hunters who were unable to catch anything in their nets.

This shared portion is called the *einda*. It is believed that game will not be caught if the *nkanga* is coated with the scent and blood of the kill, so he remains at a distance from the place of slaughter. Nor does he carry his own portion of meat (*eyali*) home with him; someone else carries it for him.

If no game is caught even after the *nkanga* applies the medicine to the nets, the hunting party simply goes home. If, however, these hunts repeatedly yield no game, the hunting party will have the *nkanga* go to a *nkangosako* magician and consult the ancestral spirits (*bolimo*).

Unlike collective bow-and-arrow hunting, net-hunting has the advantage that animals caught inside the net can be taken practically by hand. However, positioning and taking up the nets and transporting them is hard physical work, and repeating this process half a dozen times in one day makes the Ngandu reluctant to conduct large-scale *botai*.

In order to become a *nkangotai* or head of a *botai* net hunt, one must present one's teacher with gifts (*bosambo*), consisting of one *poo* spear and one *ihaka*-type short sword, both of which are also used as a part of the *ngando* bridewealth (Takeda, 1991). There are ten different types of short swords, each with a different name, in the Ngandu. Three months after the first presentation of gifts, another set of these same gifts must be given to the teacher. The teacher and pupil then go on a *botai* hunt together, but unlike the case of the *nkanga-lusala*, there is no *botono* taboo.

The *nkangotai* cannot eat the following portions of a kill: *litombe* (diaphragm), *leeleme* (spleen), *liko* (liver), *chungu* (buttocks), *liyomo* (the portion around the neck section of the animal which is a taboo applicable to the blue duiker and other *nyaama-kolomo*), *boote* (head), and *lisolo-looloko* (lungs and heart). As to the latter two portions, for some animals there are restrictions, but for others, they may be eaten. Namely, heads of the blue duiker and *nyaama-kolomo* are eaten, but not the head of the buffalo, yellow-backed duiker, Peter's duiker, or bay duiker. The head of the bushpig and water chevrotain is given to women, although men, too, may eat it if they so desire. In addition, the *lisolo-looloko* of the blue duiker, water chevrotain, and *nyaama-kolomo* is eaten, but not the lungs (*lisolo*) of the bay duiker, yellow-backed duiker, and Peter's duiker. These restrictions also apply to the *nkangohonda* or head of a *bohonda* net hunt.

(2) *Bohonda*: Net-hunting for bushpigs

The traditional *bohonda* net is the coarsest net with a mesh size of over 20 cm. The string of the net is about 5 mm thick and the net itself about 1.3 meters high. A net 20 meters in length requires the connection of about 15–20 smaller nets, and it is said that as many as 40 nets have been joined together at one time for a *bohonda*; this larger net forms an enclosure called an *elonga* and is used chiefly in hunting herds of bushpigs (*botonga-bosombo*; plural, *betonga-basombo*), although it is also used to catch buffalo and large antelopes. The *bohonda* net is strung high to catch buffalo and dropped low (in fact touching the ground) to catch bushpigs. It is too big for *nyaama-kolomo* and small antelope like the blue duiker, and even small bushpigs, which can escape by wiggling through the mesh. Sometimes even medium-sized antelope like the Peter's duiker and the bay duiker, too, will wiggle through the mesh of the *bohonda* net and escape.

There are two types of *bohonda* net hunts. One type is directed by a *nkangohonda* (bushpig charmer), a sorcerer hunter who handles bushpigs as easily as if they were dogs, gathering herds of them around him and even holding them by their necks. Another type is conducted without the participation of a *nkangohonda* but instead, under the control of a special hunter, known as an *ichachi*, who is also familiar with the habits of the bushpig.

Scouts (*boluka*) working separately in different directions go into the forest before the hunt begins, traveling up to 8–9 km in their search. The hunt begins when the scouts find either herds of bushpigs at rest (*bobetto*) or on the prowl for food (*buso*). The *boluka* scouts, who have ascertained the place where the herd rests or sleeps, head back to the *eombo* starting point where the *nkangohonda* and the rest of the hunting party (*botohonda*) are waiting with their nets. In order to make sure they do not lead the hunting party astray when they return to the herd, the scouts mark the path by breaking tree branches (*buune*)⁽¹⁷⁾ and play their gourd flutes (*chichi*) on their way back to the *eombo* starting point. The hunting party in turn responds by playing their own *chichi* flutes. Upon the scouts' return to the *eombo*, the *likunda* (the bag made of animal skin which contains the *boote* medicine for the *bohonda*) is thrown by the *nkangohonda* and it must be caught by one of the scouts. It is believed that if the *likunda* is not caught, then the hunters will not catch any animal from the herd the scouts have sighted.

The *botohonda*, or those in charge of nets, also carry spears. The *lichindo* as beaters who are also carrying bows and arrows, hide behind trees inside the *elonga* and wait for bushpigs to pass by. When the pigs appear, the *lichindo* shout and clap their hands in order to frighten the pigs and try to drive them into the nets. The *nkangohonda* hunts along with the *botohonda* net carriers and the *lichindo* beaters, but he is unarmed and carries only a *tombi-ya-baango* (*bolende* genet pelt bag) containing a *pongo* horn flute slung over his shoulder.

In addition to a horn flute, there are also inside his *tombi-ya-baango* bag, the pelt of the *simba* genet, the pelt of the *iyonge* otter, two *bolongo* (steel armbands), and an *iloho* (the *chichi* gourd flute containing the *boote* medicine for the *bohonda*). He alone approaches the herd, drawing the herd around him while snapping his fingers. Such an act is called *lokoko*, and the sound is like that made by pressing the side of the crooked little finger of the left hand with the middle and ring fingers of the right hand. Meanwhile, the rest of the hunting party spread the net and wait at

their stations. The *nkanga* checks to see if the net has been readied by the group by means of his *pongo* flute; when all is ready, he draws the herd into the enclosure formed by the *bohonda* net. After he has sent the herd ahead he leaves the rest to the *lichindo* beaters hiding behind the trees. The *lichindo* frighten the bushpigs that pass nearby and drive them toward the net. The *nkangohonda* does not sit in front of the net (*booya*) as the *nkangotai* does, but instead stands inside the *elonga* net-circle. The frightened herd runs toward the net in an effort to escape, but they are attacked by the spear-wielding *botohonda*. If their spears are not enough they also use their short swords. The *botohonda* stand behind the net when handling large animals such as bongo and buffalo, but they stand in front of the net to kill the smaller animals like bushpigs and sitatunga. It is said that the black-fronted duiker is never caught together with the bushpig in a *bohonda* hunt, and, even if it is, it must be let go after having its ears clipped. The Ngandu believe that if a black-fronted duiker trapped in this way is killed, no more bushpigs will be caught.

Bohonda net-hunting led by *nkangohonda* usually net anywhere from three to 12 bushpigs, with catches of up to 20 being reported.

If the *bohonda* hunt results in the capture of a buffalo or bongo, both the net and the first spear to hit the animal must be given to the *nkangohonda*. Spears used on bay duiker, Peter's duiker or yellow-backed duiker must also be given to the *nkangohonda*.

Bohonda in which the *nkangohonda* does not participate can be conducted with just one *ichachi* hunter specialist for bushpigs, but usually two or three are required. It can be done with just one net. The *ichachi* imitates the sound of the bushpig and brushes the ground with a broken branch to lure the herd into the *elonga* net-circle, whereupon he frightens the herd into the net. Unlike the *nkangohonda*, the *ichachi* is not unarmed; he carries a spear or a short sword.

A *bohonda* led by a *nkangohonda* requires about 15 people, whereas a *bohonda* conducted by *ichachi* can be carried out with just a few people, including women for *botohonda*.

When a *nkangohonda* is invited to conduct a *bohonda* net hunt, he is paid for his services with just two chickens, but the *nkangohonda* must be taken care of (i.e., given room and board) until such time as a herd of bushpigs is discovered by the *boluka* scouts. The people who invite the *nkangohonda* must provide not only him with room and board; they must also provide the same services for the *boluka* scouts and the *botohonda* hunters who accompany the *nkangohonda* and help him. The economic costs to those inviting the *nkangohonda* are therefore quite heavy. *Nkangohonda*, like *nkangotai* and *nkanga-lusala*, are few in number, but there is a fairly large number of people who can assume the role of the *ichachi*. The physically exhausting task of carrying the nets and the substantial material and monetary costs required to become a *nkangohonda* have caused a decline in the incidence of *bohonda* netting.

The sole surviving *nkangohonda* among the Ngandu is an old man born in 1909, who lives in Pombi, a village in the Djolu Zone about 25 km east of Wamba (0°10'N, 23°30'E; refer to Kano, 1987, 1996, for folktales of the Ngandu, and Kimura, 1991 for daily activities and social association of the Ngandu around Wamba in Djolu Zone). He has no pupils. He became a *nkangohonda* in 1945, but a *bohonda* has not been conducted since 1959.

In order to become a *nkangohonda*, one must make an initial payment to a teacher (such payment being called either *bolengo* or *lokenga*) of one steel arm band (*bolongo*), a kind of traditional knife called a *lokenga*, one short sword, one spear, one chicken, and one bunch of bananas. The teacher then uses a *lokenga* knife to make incisions in the pupil's forehead between the eyebrows, wrist, elbow, and along the backbone, into which he rubs medicine associated with the *bohonda*. The content of this medicine is secret and further detailed information cannot be obtained. On this day the pupil is forbidden either to wash or to sleep with a woman. The teacher accompanies his pupil to the pupil's village, and on the evening of a day of rain plays his gourd flute (*chichi*) and announces the initiation of a *bohonda* net hunt the next morning.

Women must not eat of the first bushpig or male bongo caught in this *bohonda*, although they may eat any female bushpigs caught. It is said that those who violate this restriction will be afflicted with diarrhea. The *nkangohonda* carries with him the medicine needed to cure it (Takeda, 1987, 1991). If no bushpigs are caught, the legs of a blue duiker captured alive in the *botai* hunting are tied and the duiker brought back to the village. On the return, the *nkangohonda* is informed by the playing of the *chichi* flute that a blue duiker has been taken in the hunt. The *nkangohonda*, upon hearing this, takes the *tombi-ya-baango* string bag out of his house and awaits the return of the hunting party. He then slits the throat of the duiker and pours the blood into the *pongo* horn. He alone eats the cooked duiker; the remains are not even given to the dogs but are consigned to the fire. Upon payment to his teacher of a second installment (*nyongo*), consisting of 20 chickens, one *botai* net, 50 zaïre in cash and the 40 items of the *bosolo-ya-bakoko* (goods used as bridewealth or dowry) such as short swords, spears, and copper bands of *baango* and *bolombolombo*, the pupil becomes a full-fledged *nkangohonda* in his own right.

A *nkangohonda* never eats the meat of the bushpig, of course, nor of *nyaama-lokolo* animals such as the yellow-backed duiker, black-fronted duiker, sitatunga or bongo, nor of the black mangabey, mona monkey, buffalo or *nchula* (electric catfish; *Maloterurus electricus*). When he eats chicken he must not share it. The children of the *nkangohonda*, however, provided they have learned the medicine of the *bohonda*, may eat the chicken with him. The *nkangohonda* does not eat with children who have not learned this medicine, or with his wife, or with any other people (Takeda, 1984).

Ichachi, unlike *nkangohonda*, are not constrained by such taboos surrounding the consumption of meat.

Bay duiker and Peter's duiker taken in the *bohonda* net hunts must not be eaten by women or childless men (*bolenga*; Takeda, 1990, 1991). It is also stipulated that all women must eat of the male yellow-backed duiker, buffalo, and bushpig.

(3) *Botoke*: Monkey hunting

This type of hunting involves finding a troop of monkeys (principally the red-tailed monkey and black mangabey, which form troops of 20–30 individuals). All the trees near the trees in which the monkeys have been found are cut down. Fine-meshed nets (*bomboloko* or *botenga*) are spread under the remaining trees and the monkeys are then forced into them. A *nkanga* may or may not be present on these hunts. About five to eight nets are needed, requiring about 20 participants, with

the sequence noted above being repeated four or five times a day. Such *botoke* are mainly conducted at Sema and Wamba by the Ngandu in the Djolu Zone.

After the nets have been spread, one or two participants climb the trees which the monkeys are in and bring them to the ground. Members of the hunting party who have brought dogs are stationed inside the enclosure (*iyanjyo*) formed by the nets, and when the monkeys are dropped from the trees, the dogs chase them into the nets. In the case of the *iyanjyo*, the net completely seals the area and there is no exit, although in the case of *botai* or *bohonda* net-hunting, the net enclosure (*elonga*) does have an exit. Hunters stationed both inside and outside the nets kill the monkeys with hatchets or spears.

Ekolo are small-scale versions of the *botoke* monkey hunt, in which monkey troops are discovered by chance and hunting is spontaneous. If troops are discovered in the vicinity of a village, the help of villagers is easily obtained in an attempt to capture a solitary monkey (*etoi*, although a solitary animal living on the ground is called *likkengi*) or small groups of monkeys (*botonga*). In addition to small groups of mona monkeys and Angolan black-and-white colobus, *ekolo* are attempted also with individual red-tailed monkeys and black mangabeys. *Ekolo* are conducted at Ilongo and Pango in the Ikela Zone as well as at Wamba. Unlike a full-scale *botoke*, these smaller hunts are done only once, and can be conducted with about ten people.

Limbimbi, another method of catching monkeys, involves tying ropes to branches across which the monkeys are likely to travel as they move through the trees (such a trail or path on which monkeys walk in the trees is called *bekonongo* or *tange*). The hunters wait below the trees and, calculating the exact moment when the monkeys will cross the junction, give the rope a sharp jerk towards the ground. Monkeys falling to the ground are then killed with hatchets or spears. This method is also tried in conjunction with either the *botoke* or the *ekolo*.

3. *Paho-ambwa*: Hunting with Dogs

Paho-ambwa, which uses dogs wearing wooden bells around their necks (*eelaho*; Fig. 2), are of two types: *beenga*, the chasing of tree-dwelling monkeys, and *lookwa*, the hunting of small ground-dwelling animals. Dogs are essential for driving prey in such hunting methods as the *botai* net hunt and *botoke* monkey hunt, but they perform especially valuable tasks in the *paho-ambwa*. However, not all dogs are suitable for use in hunting.⁽¹⁸⁾ Upon marriage among the Ngandu, dogs form part of the dowry given by the bride's people to the groom's (Takeda, 1984, 1990, 1991). In general, dogs are treated well and even given the same food (cassava: *Manihot esculenta*) that people eat; nevertheless they often go hungry.

In the *beenga* hunt, because monkeys have excellent hearing, leaves (*lilinde*) are inserted between the wooden clappers of the dog's *eelaho* bell to muffle their sound and the dog is carried under the hunter's arm (*shalokangu*) until a monkey troop has been sighted. Then, the *lilinde* leaves are removed, and the dogs are set down to track the monkeys. The hunter, equipped with bow and arrows, follows the sounds of the *eelaho* bell and the dog's barking.

Sometimes the hunter will urge the dog on by shouting, never letting it rest from its pursuit. Tired monkeys making a last stand are then brought down with arrows. The *boswe* used in *lotongo* (individual bow-and-arrow hunting) to draw the monkeys

closer is not used in *beenga* hunt. *Boswe*, essentially a combination of tracking using a dog and bow-and-arrow hunting, can be done with one dog and one man. The running, and sometimes tree-climbing, required to keep up with a dog driving a monkey is exhausting, so *beenga* hunts are no longer frequently conducted.

Usually, *paho-ambwa* hunting with dogs means *lookwa*. *Lookwa* is a form of hunting which relies on the dog's keen sense of smell to discover the nests (*liyoka*) of *nyaama-loshe* such as porcupine, mongoose, genet, water chevrotain, etc., close to rivers or in holes in trees. While it is possible to conduct these hunts with one dog and one man, they are typically conducted with two, three, or at most four people. Up to four dogs are used, but all the dogs always belong to only one of the hunters. The one person who brings the dogs (*mene-ambwa*) also brings one *botenga* net to spread around the nest and one spear. The other hunters usually bring bows and arrows and shoulder bag-like nets called *tombi*, *bopone* or *iteko*, with which to seal any other exits (*bongo*) from the nests. All three are made from *lokosa* string. The *tombi* is a mans' shoulder bag, usually used to transport animals taken in the hunt and, as a rule, carried by the youngest of the hunting party. The latter two, however, are used for hunting only. The *bopone* is a larger bag-net than the *iteko* and is also used in net-hunting.

The dogs use their sense of smell to find the *liyoka* nests. When the dogs start to move ahead rapidly the hunters take no particular precautions, but they move stealthily when the presence or apparent presence of animals is detected. At that point those following the dogs spread their nets around the nest and prepare to seal the exits. The hunters drive the animals from the nest by hitting it with sticks, and set the dogs on any animals that escape prematurely. When hunting brush-tailed porcupine in hollow trees or holes in fallen trees, the hunters use *tombi* bags to seal one exit and drive the animals into the bag by thrusting a stick into the other exit. If the animal remains in the hollow tree after the hunters have sealed it with *tombi* bags, they will cut the tree down. However, if the animal is accidentally injured and starts to bleed, the hunters stare at it in fright; such an animal comes under a type of consumption regulation called *beenga* or *bolenga*. This is mainly a dietary restriction applicable to unmarried men, which forbids them to eat either juvenile or adult brush-tailed porcupines (Takeda, 1984,1990).

Animals caught in the *tombi* bag or *botenga* net which are injured and bleed also fall under this injunction. If the porcupines are seen to be injured, the hunters seize them with both hands around the neck, where the quills are shortest. When animals are in the hollow of an upright tree, the hunters seal the exit with a *tombi* bag and then smoke them out by setting fire to round clumps of oil-rich palm fibers (*likamu*) of the mesocarp of oil palm (*Elaeis guineensis*) from which the oil has been extracted. Since these fibers contain a small amount of oil, they burn easily—they are also used as torches. Tree oleo-resin (*ichuwa*)⁽¹⁹⁾ is also sometimes used in firing the round clumps.

Porcupines taken by cutting down trees are associated with difficult birth, so pregnant women and their husbands are forbidden to eat any part of them. If a women eats food forbidden (*ekila*) to her by mistake, it is believed that the dogs used in the *paho-ambwa* hunting will be stricken with a disease called as *buugano* and be unable to catch game. The Ngandu, however, know how to cure such a disease. The remedy for it consists of placing the sap of the *bolengalenga* vine (*Cissus*

dinklagei, Vitaceae) in a pot where it is combined with boiled and cooled chunks of bark (*ehase*; plural, *bihase*), obtained by beating the *liiye* tree (unidentified) with a machete. The afflicted dog is placed in a *losingi*-type basket and the liquid is poured over it starting from its head.

Those going on a *paho-ambwa* hunt with dogs, take care to avoid being seen entering the forest by their fellow villagers, who in turn must not look on as the hunters enter the forest. Accordingly, when leaving for a *paho-ambwa*, the hunting party usually slips out of the village unseen. The villagers refrain from sticking their heads out of their houses in an attempt to ascertain the direction in which the hunters have gone. Also, when those who have prepared the *botenga* net or *eeleho* dog bell to be carried on the *paho-ambwa* come to the *losombo* (gossip hall), those present in the *losombo* hall who are not going on the *paho-ambwa* will leave the *losombo* hall and return to their homes with their eyes downcast in order to avoid eye contact with those going on the hunt. These people must then return to the *losombo* once those who are going on the *paho-ambwa* are safely out of sight.

4. Hunting with the *Tombi* Shoulder Bag used by Men

The men's *tombi*, or shoulder bag, is used in the *paho-ambwa* both to seal the exits of an animal's lair, and to catch birds, bats, and small rodents living in holes in trees. This method requires at least two people. When an animal is discovered in a hole in a standing tree, one man climbs the tree to cover the hole while a second drives the animal aloft by poking into a stick into the hole from below. Squirrels, flying squirrels, and bats such as *lukio*, *lolema*, *indumba*, *lingwengwe*, and *lokoku* are also hunted.

5. *Losongo*: Individual Spear Hunts

Losongo refers to a traditional nighttime individual hunting technique for bush-pigs, etc., using spears. It has not been carried out recently. Most Ngandu men carry a spear when they go into the forest so they are ready to attack animals they encounter along the way. Spears are also used in other types of hunting. For example: during a *bohonda* hunt, the *botohonda* is poised not with a bow but with a spear; in the *paho-ambwa*, the man who brings the dogs (such a hunter is called the *mene-ambwa*) also brings a spear, spears are used in the *botoka* and with the *esongo* elephant trap as well.

There are 16 different types of spearheads, classified according to differences in shape, number of holes, etc., including six or seven types which are used for killing animals. *Poo* spears, described earlier (see also Note (14)), are of major importance, but have no practical use in hunting.

6. *Lingona*: Hunting with Guns

In 1974, the government confiscated all firearms, but there are some people who can make their own rifles (*karibuule*). One man living at Yalisele near Wamba in the Djolu Zone, who was born in 1935, is the first man among the Ngandu to have made a gun by hand. People who make such guns are also found at Likonda and

Bokumba in the Djolu Zone. It seems that recently men who can make guns have appeared at Yokamba in the Ikela Zone, as well. Homemade guns are mainly used to shoot tree-dwelling monkeys. At a price of 40 zaïre each, they are too expensive to be used in hunting with any frequency. The technique of making bullets⁽²⁰⁾ is unknown among the Ngandu people, so commercial ammunition is used, which is not only expensive but also very difficult to obtain. Guns made in Zaïre are not taxed. Occasionally, men using boats equipped with outboard motors from the area around Mbandaka, capital of the state of Equator, come up the Maringa River to conduct elephant hunts in the forests of the Ngandu with imported high-power rifles (*monje*). Sometimes money is paid and a hunting permit obtained, but poaching for elephant tusks is common, with those living nearby fighting with each other over the meat of the elephant carcasses left behind by the poachers.

In short, hunting with guns has never developed as a form of hunting in the forests of this area.

7. *Botoka*: Elephant Hunt

Elephants are not only frightening to the forest people, they also ravage the cassava,⁽²¹⁾ sugarcane and bananas which the people have planted. If an elephant appears in the vicinity of their homes or fields, the villagers rush out en masse and shout and beat the ground with sticks to frighten it off (an action called *ikongolole*). During a night time *ikongolole*, bundles of bark from the *likoke-ya-bohola* tree (*Macaranga* sp.) are lit as torches to menace the elephants. The villagers also erect defenses around their fields to protect them against damage from elephants (*boote-a-njou*). These defenses consist of the slender trees of *bulutenge* (*Palisota brachythyrsa*) or *bohoholi* (*Ritchiea aprevaliana*), stuck into the fields and *bowe* or *liluku-ya-jamba* (*Sterculia bequaertii*) fruits from the *bowe* tree are buried in the fields.

In the *botoka* type of elephant hunt, the hunters erect a vine platform (*eliko*) in the trees. They wait on the platform until an elephant passes underneath. Then they hurl a heavy pole fitted with a lance called a *bonga* (Fig. 3) at the elephant. There is no *nkanga* present at a *botoka* trap. This kind of hunting is only attempted on bright, moonlit nights. The method requires long waits on the platform in the trees and is physically taxing, and for this reason it is rarely practised nowadays. In this respect, the *elongo* and the *esongo* elephant traps, though dangerous enough to cause harm to the unwary individual who happens to walk into them in the middle of the forest, are a much more advantageous means of hunting elephants.

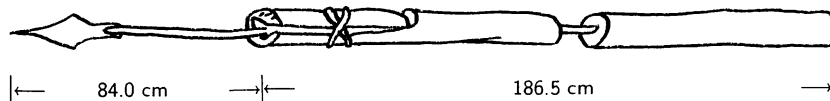

Fig. 3. *Bonga* or a heavy pole with a spearhead for hunting elephant in *botoka*.

A *bonga* pole weighs 4.75 kg. The main wooden body is made from the trunk of the heavy *esekeseke* tree (*Memecylon jasmuncides*). There are 16 types of Ngandu spearheads, and most may be used for this purpose. However, the decorative types of spearheads like *poo*, which are usually exchanged as bride wealth, are not effective in hunting.

Table 1. Traps used by the Ngandu.

Local name	Trap-setting site		Major trapped animals			Materials for traps
	Ground	Tree	Mammals	Birds	Others	
Spring traps						
<i>nilo</i>	x		s, m	tb		nylon string
<i>zekki</i>	x		m			wire
<i>imote</i>	x		s	tb		<i>lokosa</i> (<i>Manniophyton fulvum</i>)
<i>lokinga</i>	x		s	tb		<i>liheke</i> (<i>Raphia gentiliana</i>)
<i>bomboka</i>	x	x	s		rt	wire
<i>bopata</i>	x		s, mk			<i>lihike</i>
<i>imboka</i>	x		s			<i>bokombe</i> (<i>Haumania</i> <i>liebrechtsiana</i>)
						<i>longoli</i> or <i>bokamba</i> vine (<i>Eremospatha</i> <i>haullevilleana</i>)
<i>bohaso</i>	x	x	s	s		<i>longoli</i>
<i>ilongalotomba</i> ⁽¹⁾ (= <i>ilongileleko</i>)	x		s			<i>bokombe</i> , <i>longoli</i>
<i>ilongaliyalitoko</i>	x		s			<i>bokombe</i> , <i>longoli</i>
<i>ilongaliyaekochi</i> ⁽²⁾	x		s			<i>bokombe</i>
<i>ilongaitoli</i> ⁽³⁾	x		s			<i>bokombe</i>
<i>ilongaliyaechichi</i>	x		s			<i>bokombe</i>
<i>italabai</i>	x		s	tb		nylon string, <i>lokosa</i>
<i>inyate</i>		x		s		<i>longoli</i>
<i>bokolo</i>	x		m, l			<i>ntofe-mwindo</i> (<i>Landolphia glabra</i>)
						<i>longoli</i> or <i>bokamba</i>
<i>lipuchu</i> ⁽⁴⁾	x			bp		<i>lokosa</i>
Deadfalls						
<i>botamba</i> ⁽⁵⁾	x		s			heavy pole
<i>ekwata</i> ⁽⁵⁾	x		s			heavy pole
<i>ikuliya</i> ⁽⁵⁾	x		m, mk			heavy pole
<i>lilika</i> ⁽⁵⁾	x		m, mk			heavy pole
Snares						
<i>bopachi</i>	x	x	mk	m		<i>lokosa</i>
<i>boneyi</i> [*]	x		mk	hb		<i>lokosa</i>

Local name	Trap-setting site		Major trapped animals			Materials for traps
	Ground	Tree	Mammals	Birds	Others	
Spiked traps						
<i>elongo</i>	x		k			spear (steel)
<i>bolongo</i> ⁽⁶⁾	x		m, l			spear (wooden)
<i>esongo</i>	x		l			spear (steel)
Bag nets						
<i>iteko</i> (= <i>konongo</i>)*	x	x	s			<i>lokosa</i>
<i>bopone</i> *	x		s			<i>lokosa</i>
<i>bolongwa</i> *		x	mk			<i>lokosa</i>
Other methods						
<i>kombelia</i> (= <i>bompone</i>)* ⁽⁷⁾	x			tb		wooden cage
<i>bokosa</i> (= <i>lopote</i>)	x			s		resin of <i>luna</i> or <i>bese</i> tree (<i>Landolphia</i> <i>congolensis</i>) or <i>bosenda</i> (<i>Saba florida</i>)

For the details of hunting methods, see also Takeda (1978, 1984).

bp: birds of prey like African crowned eagle or African fish eagle; hornbills; k: king sized; like elephant or hippopotamus; l: large-sized; m: middle-sized; mk: monkeys; rt: reptiles; s: small-sized; tb: terrestrial like crested Guinea fowl or Congo peafowl.

*: The trap must be watched by the trapper on the spot where it is set.

- (1) Fruits of *boleko* (*Ongokea gore*, Olacaceae) are used as bait, and the seeds (Irvine, 1961) are also used as bait for small rodents.
- (2) Steamed cassava is used as bait.
- (3) Flowers of *bosomboko* ginger (*Aframomum* sp., Zingiberaceae) which giant rats like, are usually used as bait.
- (4) Skins of monkeys or other animals are used as bait. *Imote*, a kind of spring trap is also set.
- (5) Termite hills or stones are used as a weight for pressing down.
- (6) Pitfall is also dug in the ground.
- (7) Sometimes *imote* is also set in front of the entrance of the nest.

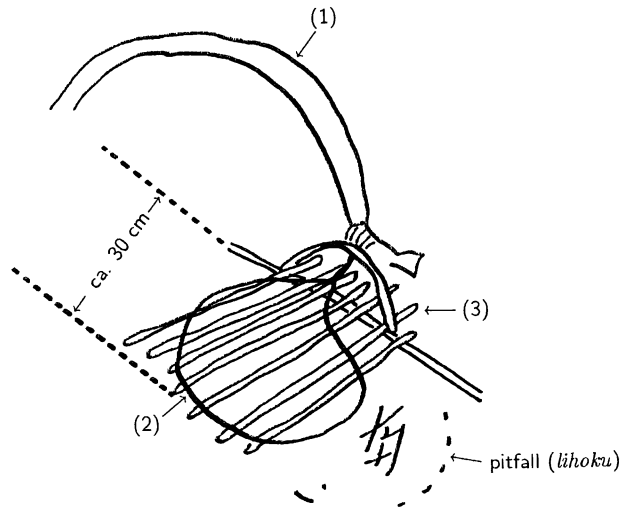

Fig. 4. *Imote* or a spring trap for terrestrial birds like Guinea fowls and Congo peacocks.

- (1) *sumbe* spring pole: made principally from the *elimilimi* tree (*Dialium* sp.). When a bird treads on the *lihoku* pitfall, it releases the *sumbe* and so fastens the victim with the snare of nylon string.
- (2) *lokala*: several twigs of the *bongombigombi* tree (*Scaphopetaluma thonneri*) are bridged across the *lihoku* pitfall.
- (3) snare: made of nylon string attached to the end the *sumbe* spring pole.

II. Lilongi or Longongo: Trapping

The Ngandu presently use or have used in the past some 31 kinds of traps (Table 1). Over half of these are spring traps. The Ngandu closely observe animal trails to determine where to set their traps. They set traps on *bolela* (trails used by small rodents), *boshilo* (trails used by antelopes, bushpig and buffalo), and *busambi* (elephant trails). Traps are also set in the trees on the trails of tree-dwelling monkeys. Such trails are called either *bekonongo* or *tange*.

1. Spring Traps

A spring trap works by using a flexible stick, two to three centimeters in diameter, as a mainspring or brace (*sumbe*), and utilizing the repulsive tension of the stick as it is bent such that animals caught in an attached binding ring are hoisted aloft. *Bowe* tree, *boilu* tree (unidentified) and *elimilimi* shrub (*Dialium pachyphyllum*) are widely used for the main spring *sumbe*, but any saplings growing near trap sites may be used. One end of the brace is anchored deep in the ground and the other is bent.

The Ngandu make four main types of spring trap which are illustrated in Figures 4 to 7. The *imote* trap (Fig. 4) uses a *lusuma* slender vine to attach the *lisili* (or binding ring which closes directly around the animal) to the brace. The *lusuma* may

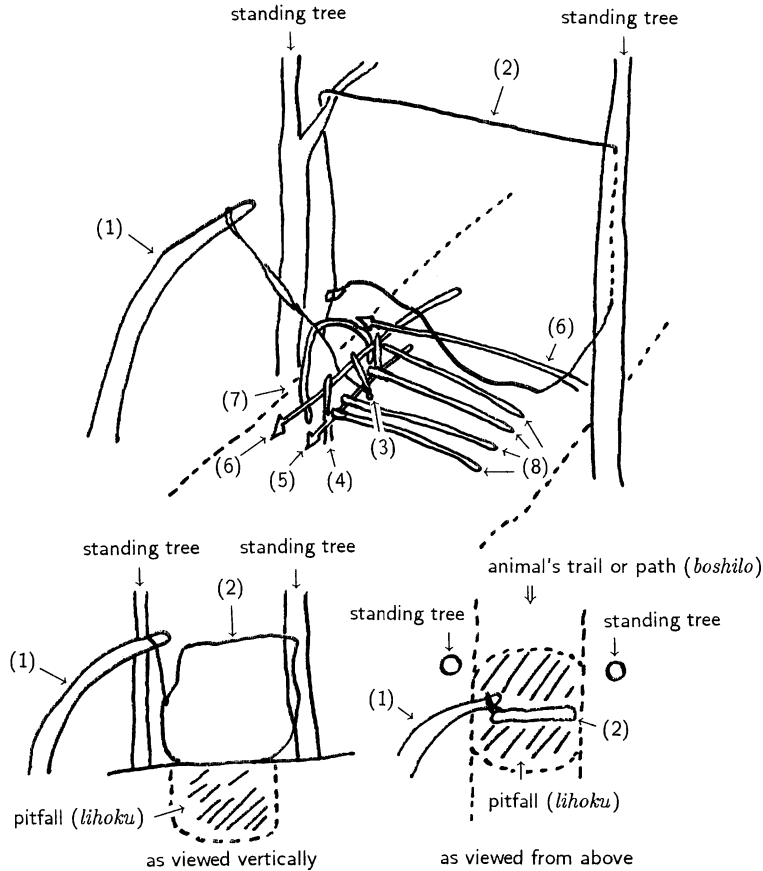

Fig. 5. *Nilo* or a spring trap for trapping terrestrial birds and small-sized mammals such as the blue duiker or brush-tailed porcupine.

The snare of a *nilo* trap is made of nylon string. A nylon string thicker than one centimeter in diameter makes the trap strong enough to catch even a Peter's duiker, yellow-backed duiker, bay duiker or bushpig. However, a *bombombo* vine (*Dalhousiea africana*) of 1.5 to 2 cm in diameter is used for the *lusuma* string when trying to trap these large game animals.

- (1) *sumbe* spring pole: a branch of the *bowo* (*Sterculia bequaertii*), *elimilimi* (*Dialium* sp.), or *boilu* standing tree is usually used, but other species of trees found near the point where a *nilo* trap is set, may also be used.
- (2) *lusuma*: a *bohkehikeki* (*Dioscorea smilacifolia*), *longonge* or *itohe* vine connecting a *nilo* string and a *sumbe* pole.
- (3) *nilo*: a nylon string.
- (4) *boleka*: a trigger twig.
- (5) *ibelelahokitwa* or *ingitwa*.
- (6) *ekoko*: a twig which presses against the *lohakitwa* branch.
- (7) *lohakitwa*: one end of this branch is pressed by two *ekoko* twigs, the other is struck deeply into the ground.
- (8) *lokala*: twigs crossing above the *lihoku* pitfall.
- (9) *lalanga*: a kind of branch fence which guides the prey to the *nilo* trap.

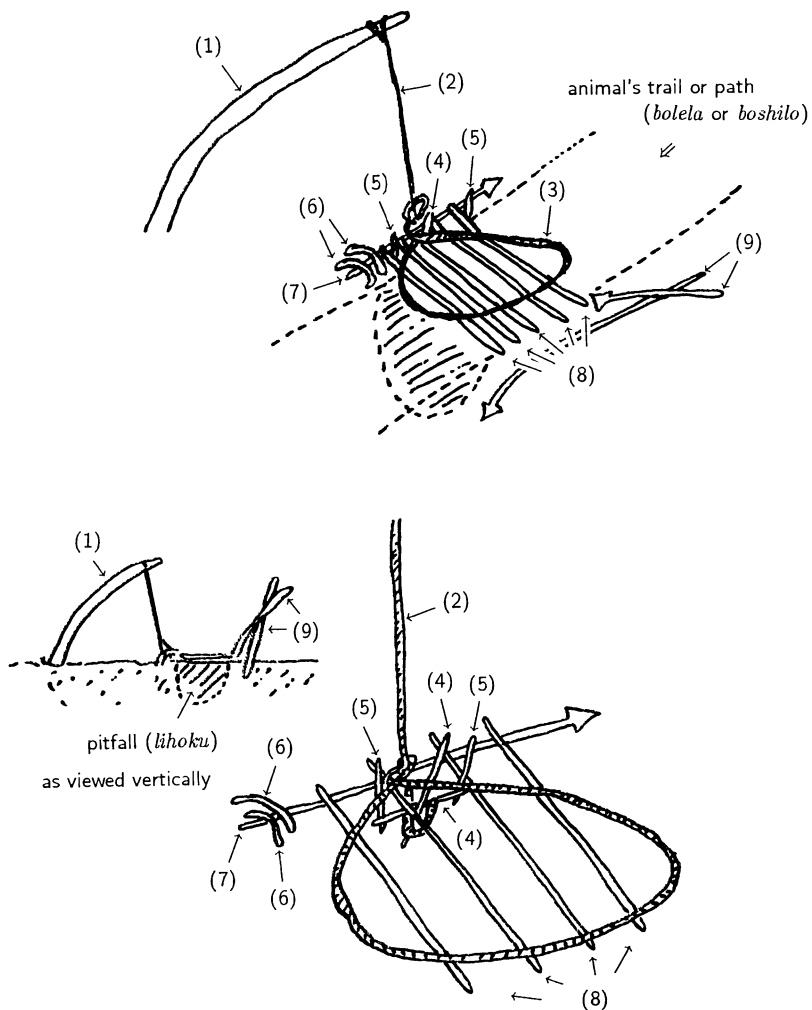

Fig. 6. *Bokolo* or a spring trap for trapping large-sized mammals.

- (1) *sumbe*: a spring pole.
- (2) *lisili*: an *itohe* or *longoli* vine is used for this snare.
- (3) *boleka*: a trigger made of a short twig.
- (4) *ingitwa* or *ibeledalohakitwa*: a twig which supports the *ibebeleka* and *lohakitwa*.
- (5) *ibebeleka*: a branch which supports the *boleka* trigger and the *lokala* cross bars above the pitfall.
- (6) *lohakitwa*: two branches—one presses the *lisoso* branch and presses the first *boleka* and the *ingitwa* twigs, while another one presses against the *lohakitwa* on one end.
- (7) *lisoso*: a bent branch from which the *boleka*, the *ingitwa* twigs and the *lohakitwa* branch rest.
- (8) *lokala*: twigs (*ibeledokala*) crossing above the *lohoku* pitfall. Leaves and soil called *lokumbo* or *lukkundo*, which cover the *ibeledokala* twigs to conceal the pitfall.

be made from *bohekiheki* (*Dioscorea smilacifolia*, Dioscoreaceae), *longonge* (*Baisea leonensis*), *ntohe-mwindo* (*Landolphia glabra*) and *bombombo* (*Dalhousiea africana*) vines. If the *lusuma* is made from rope purchased with cash, the traps are called *nilo* (Fig. 5). Traps in which the binding ring is tied directly to the tip of the *sumbe* brace without the use of the *lisili* are called *bokolo* (Fig. 6). Traps which use a Y-shaped branch from trees such as the *esekeseke* (*Drypetes cinnabaricana*), *bokumbo* (*Leonardoza romii*) and *bongolu* (*Irvingia gradifolia*) between the *lusuma* and *lisili* are called *zekki* (Fig. 7). The binding ring is made from several strands of thin steel wire purchased with cash. *Zekki* traps are used to catch medium-sized mammals such as bushpigs and are constructed so that, even if an animal caught in the trap struggles and the binding ring gets separated from the *sumbe* brace, the animal will not go far because the Y-shaped branch attached to the wire will eventually snag on standing or fallen trees, effectively trapping the animal.

The Ngandu now disdain the use of traditional materials such as tree bark and vines for the *lisili* binding ring, preferring instead semi-indestructible manufactured products such as nylon and wire.

When hunting with spring traps the Ngandu erect stick fences along animal trails as diversions to lead the prey to the areas where the hunters have dug a hole (*lihoku*). The hunters cover the hole with a light screen of several sticks arranged in rows, lay the binding ring over the screen, and camouflage the whole device with dirt and leaves. An animal stepping into the trap instantly releases the binding ring trigger (*boleka*), which in turn releases the bent *sumbe*, that snaps upright, closing the binding ring on the animal and hoisting it into the air. The Ngandu use a different system to snare ground-dwelling birds such as the crested Guinea fowl and *bonjemba* bird (*Himantornis haematopus*) (which, while capable of flight, mostly tend to move along the ground), small ground-dwelling mammals and tree-dwelling animals. The hunters attach the binding ring directly to the brace and do not dig a hole.

The Ngandu have three types of traps in which they use food as bait. The food is specific to the target animal, and is hooked onto the trigger. In all three types, the trigger is released at the moment the bait is taken and the binding ring closes around the animal. The fruit of the *boleko* tree (*Ongokea gore*) is used as bait for the giant rat (*botomba*) trap called the *ilongalotomba* (Fig. 8), while cassava and the flower of the African ginger are utilized to bait traps for other animals.

The trap called *lipuchu* is designed to catch the *punungoli*, a bird of prey that soars through the air. It is constructed by sticking tree branches into the ground at an angle to form a cone-shaped cage open at the top to permit an aerial view of the bait placed inside, the opening is nevertheless too small to permit direct access to the bait. Monkey skin is used to attract the bird and a path leading to the only ground entrance to the cage is formed by two rows of sticks stuck in the ground. The trap is designed to catch birds trying to enter the cage to get at the bait.

While not common to all forms of trapping, hunters using the *zekki* or *nilo* traps may use hunting medicines handed down from a *nkanga-lilongi*, trapping specialist. In the case of the *zekki*, for example, earth in which footprints of the animals remain is placed in the shavings from the bark of such trees as *bokolola* (*Coelocaryon botryoides*), *longwakoin* (*Morinda lucida*), *bombende* (*Artabotrys thomsonii*), *itoto*

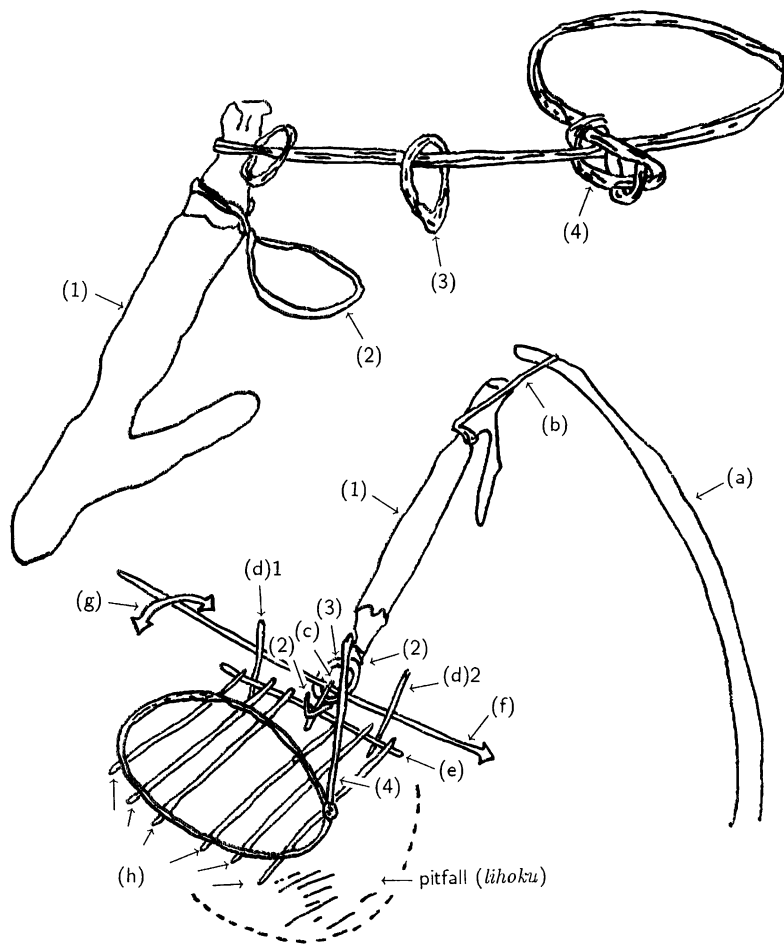

Fig. 7. *Zekki* for trapping large-sized mammals.

- (1) *likoho*: a Y-shaped bough which prevents the prey from running away with the trap by catching in a tree or similar above ground. For this reason, hard trees such as *esekeseke* (*Memecylon jasminoides*), *bokumbo* (*Leonard romii*) or *bongolu* (*Beilschmiedia corbisieri*) are used as a *likoho* bough. The bark from one end of the *likoho* bough is shaved so that the *chunyelo* and *lusuma* wires can be easily fastened.
- (2) *chunyelo*: two strings of wire.
- (3) *lisoso*: three strings of wire.
- (4) *zekki*: the main part of the trap made of 7 to 8 strings of wire.
- (a) *sumbe*: a spring pole.
- (b) *lusuma*: a longongne vine.
- (c) *boleka*: a trigger twig.
- (d) 1—(d)2: *ibelelalahakitwa* or *ingitwa*.
- (e) *ibeleleleka*.
- (f) *lahakitwa*: one end of this branch is pressed by two *ekoko* twigs, while the other is stuck firmly into the ground.
- (g) *ekoko*.
- (h) *lokala*: twigs crossing above the *lihoku* pitfall.

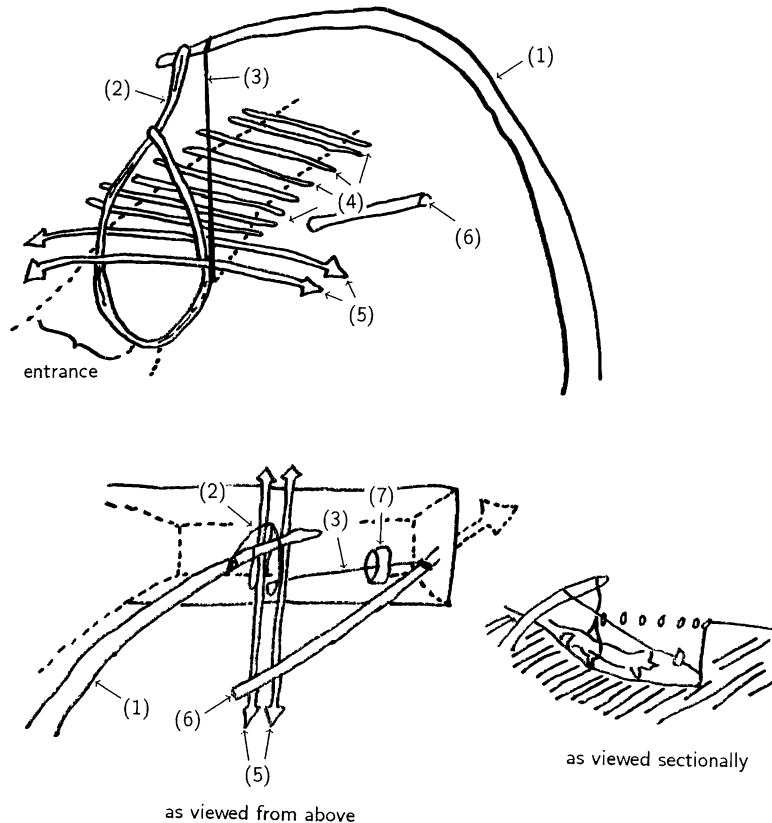

Fig. 8. *llongalotomba* for trapping giant rats (*botomba*).

This trap is set under the ground, disguised as a tunnel. A *boleko* fruit (*Ongokea gore*), which giant rats are fond of, is used as bait. Irvine (1961) records that a similar trap is used in Nigeria, although the fruits of a tree (*Carpolobia lulca*) are used as bait.

- (1) *sumbe*: a spring pole.
- (2) *lisili*: a *longoli* or *bokombe* vine is used for the snare; as *lokosa* strings or nylon are useless for this purpose.
- (3) *bokeswa*: one end of the string is fastened to the *sumbe* spring pole, while the other end is fastened to a *lohakitwa* branch (6) which is firmly stuck into the ground on the side of the hole. The string passes through a *boleko* fruit bait near one end of the string on the side of the tunnel. Once a giant rat bites into the fruit, the *sumbe* springs up and the *lisili* string tightens around the belly of the rat.
- (4) *lokala*: several *lokala* twigs are placed across the tunnel-like hole. Leaves are placed over the *lokala*, and then soil to conceal all but the entrance of the hole.
- (5) *lohakitwa*: both ends of two *lohakitwa* boughs are stuck into the ground cross-sectionally across the hole. These help to fix the *lisili* snare which is hung between the slit of the *lohakitwa* boughs.
- (6) *lohakitwa*: one end of a *lohakitwa* bough is stuck into the ground inside the hole while the other end is afloat in the air.
- (7) *boleko* fruit to lure the rat into this trap.

(*Omphalocarpum injeloense*) and *bolengalenga* vine. Sap from the *bombende* is poured over the earth and the mixture is wrapped in the leaves (*lunjyasou*) of the *ikokolu* or *lokongo* herb of the Marantaceae family. If these leaves are not available, a *lohondo* (gourd or calabash container) will do. The bundle is then carried into the forest and the liquid is poured over the camouflaged location of the *zekki*'s *lisili* through a funnel (*bongolu*) made from the leaves of the *ikokolu* or *lokongo* herb of the Marantaceae family. This procedure is repeated for each of the several *zekki* that may be in place. After the last of the liquid has been poured over the last of the traps, the funnel and the bundle are destroyed and the remaining tree bark discarded in the forest. The traps are then left unexamined for three days. On the fourth day the traps are inspected and the catch is brought home. Sometimes the sap of the *lihuluka* tree (*Celosia trigyna*) is also placed on the *zekki* for the success of the following hunt.

The hunting medicine used in nilo traps is made from the bark of *samba* or *lomba* (*Strychnos icaia*), *lihomahoma* (*Epinetrum villosum*), *lahamela* (unidentified), and *bekolo* (any tree upon which, when walking in the forest, one stubs one's toe). Sometimes the wrist of the right hand of the hunter is slashed and bleeding before he goes out to set a *nilo* trap.

The fee paid to a *nkanga-lilongi* or trapping specialist for tuition is small when compared to that paid for other *paho* or direct seizure hunting methods. For example, the fee for the *nilo* consists only of one elephant tusk flute (*bopati*) and three zaïre in cash while in the case of the *zekki* there is no fee at all if the *nkanga* and the person asking to be taught are *bokilo* relatives (brothers-in-law) (Takeda, 1991).

2. Deadfalls

There are four kinds of deadfalls. Two of them, the *botamba*, which uses a single log for the deadweight, and the *ekwata*, which uses the earth from termite mounds, are designed to crush small mammals. The *lilika* is a large-scale deadfall set near rivers that makes use of a row of several logs to crush whole herds of bushpigs and Angolan black-and-white colobus, that come to watering areas, at one stroke. The *ikuliya* is a smaller version of the *lilika*, designed to catch water chevrotain and monkeys such as Angolan black-and-white colobus and Brazza's monkey.

3. Snares

There are two types of simple snare traps, the *bopachi* and the *boneyi*. Both are designed to close on animals that crawl through the binding ring of the spring trap. The *bopachi* is set on the ground, in trees, and along river banks; the *boneyi*, designed to catch monkeys and hornbills, is set in trees and must be watched.

4. Spiked Traps

There are three types of spiked traps, the *elongo*, the *bolonga* and the *esongo* which are all designed to catch large mammals. The *elongo* is a trap for elephants and hippopotami, usually set beforehand (Fig. 9). A spear, inserted in the end of a log (*botuti*), is hung from a tree. A trip wire (*ihei*) of light rope is strung across an elephant path (*busambi*). When the elephant touches the trip wire the *botuti* pole,

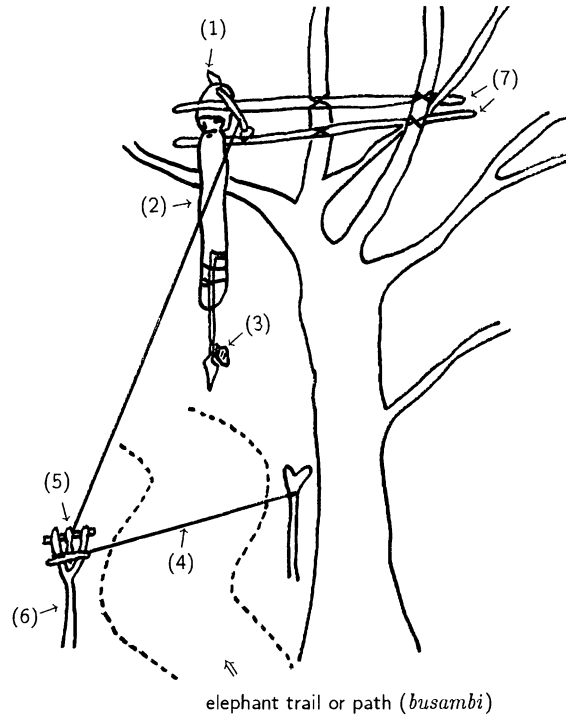

Fig. 9. *Elongo* for trapping elephants (*njou*).

- (1) *ekoho*: one end of an *ekoho* twig is shaved on both sides, and the position for hanging the *botuti* (2) bough with its spearhead, is marked on one side. At the other end of this *ekoho* twig, a *longoli* vine (*Eremospatha haullevilleana*) of approximately 8 meters in length is fastened, which connects the *boleka* (5) trigger on the ground.
- (2) *botuti*: a heavy pole with a spearhead like the *bonga* (see also Fig. 3) and with a water bag *eloi* (3) of leaves.
- (3) *eloi*: a bundle of three leaves of an *ikokolu* herb (*Sarcophyrynium schweinfurthianum*, Marantaceae) which contains soil with dried leaves and roots. The *eloi* bundle is fastened to the shaft of the spearhead. After the *botuti* pole is pulled up above an elephant trail (*busambi*), the position of the *botuti* log is roughly decided. Water, carried all the way from the village, is poured on the *eloi*, and then the *botuti* is pulled up again. The drops of water dripping from this *eloi* onto the *busambi* road, allow the hunters to determine the exact position for the *botuti* log.
- (4) *ihei*: one thin *bohekiheki* vine (*Dioscorea smilacifolia*), tightly stretched at about 30 cm above the elephant path (*busambi*). Once an elephant touches this *ihei* vine, the *boleka* trigger (5) is released on the *iyulu* twig (6) and the *botuti* instantly falls onto the shoulder of the prey. No guiding fences (*lokombo*) made of branches or twigs are set on the *busambi* road to lead the prey to the *ihei* vine.
- (5) *boleka*: a trigger twig, one end of which is fastened by a *longoli* vine to the *ekoho* (1) twig.
- (6) *iyulu*: a Y-shaped branch for supporting the *boleka* twig.
- (7) *kalangu*: two boughs which give the *ekoho* assistants a firm footing to pull the *botuti* log up the tree in which the *elongo* trap is set. The uppermost of the *kalangu* boughs helps to support the *botuti* pole. The meat of the shoulder portion of an elephant is also called *kalangu* (see also the text).

assisted by gravity, spears the animal. Setting the *elongo* trap requires a *nkangongala*, who has knowledge of the secret rites pertaining to the selection of the location of the trap and of elephant hunting in general, and two assistants (*ekoho*; plural: *bikoho*), who help set the trap. Before going into the forest to set this trap the *nkangongala* specialist must make an *ekoho*—a contraption with a stick tied to one end of an 8-meter length of a *longoli* vine (*Eremospatha haullevilleana*)—and sharpen a spear. The water is also carried in a pot and carried to the site of the trap, so that the drops of water that fall on the ground from a bundle of leaves (*eloi*) wrapped around the shaft of the instrument may help determine the exact point of the fall of the *botuti* pole.

Once in the forest the trappers pick out the tree to be used for the *botuti* pole and the two to be used for the *kalangu* logs, then they head for the trap site and begin setting the trap. The *nkangongala* on the ground gives instructions to the two *ekoho* as they climb the tree and pull up the *botuti* pole; he also adjusts the position of the *botuti* pole. The two *ekoho* assistants tie two *kalangu* sticks in place in the upper branches of the tree to support the *botuti* pole and spear (Fig. 9). Interestingly, the two sets of muscles along either side of the elephant's backbone are also called *kalangu*, and, when an elephant is killed, the two *ekoho* assistants receive this part of the meat as their *eyali* portion (see below). The hunters do not build fences (*lokombo*) along the elephant path to coax the elephant into the *ihei* trigger which is tightened above the ground like a goal line tape.

Usually, the erection of the *elongo* is carried out under the auspices of the *nkangongala*, although there are people who know the means by which such traps are set. The first installment a pupil pays to his teacher, the *nkangongala*, in order to learn the *bongala* (such payment is called *iyeecheelo*) consists of the following: one long spear and one short one, eight zaire in cash, one chicken, feathers from an *ekongo* parrot, and one *lisyuwa* (a traditional hatchet). A second installment, called *bosambo*, consists of one spear, one short sword, three arrows, one *iiwu* bed mat, one *buhongola* carrying basket, one *poke* pottery, one elephant tusk (*bopati*), one fork (*ikanga*) and one spoon (*lotoko*), a pack of cigarettes, one oil lamp (*mwinda*), and cash.

After the pupil has become a full-fledged *nkangongala* in his own right, his wife, too, in order to fulfill the requirements for becoming qualified for the *bongala* rites, must return to her father's village and collect a set of the required items to make her payment. The Ngandu are patriarchal, so those of the same lineage will help her to collect the following goods (see also Note (25)): one *bolombolombo* (the largest of the *baango* copper bands), one *iiwu* bed mat, clothes (*bilamba*), chickens, and cash. She then presents these items to the teacher's first wife. If the pupil has a second wife, she, too, in order to become qualified for the *bongala*, presents the second wife of the teacher with spears or copper bands. The *nkangongala*'s first wife, called either *boliko* or *boliko-nyaaki*⁽²²⁾, receives a portion of the *eyali* meat of an elephant caught in an *elongo* trap set by her husband; so does the second wife (*lokoli-lolimba*), if there is one. The *eyali* portion of the meat these women receive must be returned to their respective fathers' villages, unless the villages are too far away. In that case, the promised meat may be delivered on another occasion, although selling the meat for cash and sending the money to their fathers' villages is also acceptable.

The *nkangongala* is allowed to eat any part of the elephant except for the eyeballs

and brain. Nor is the *nkangongala* prohibited from consuming any other animals. When an elephant is slaughtered, the tip (*ikasa*) of its trunk (*beembo*) is cut off first by the *nkangongala* and buried nearby. The Ngandu believe that this part of the elephant's body corresponds to a human being's hands, and so no one may eat it.

A group going out to set an *elongo* trap takes care not to meet other people along the way and they must not shake hands with anyone while they are setting the trap. The *nkangongala* and the two *ekoho* assistants, after having set the trap, must not shake hands on their return to the village but must make do with verbal greetings only. It is believed that shaking hands will cause the elephant to prematurely release, with his trunk, the *ihei* trigger of the slender vine strung across the elephant trail that acts as a trip wire for releasing the trigger of the *botuti* pole hung in the trees above. If an elephant should touch the *ihei* trigger, with his trunk, the *botuti* pole would be released and the elephant would escape (Fig. 9).

The *nkangongala* and the two *ekoho* assistants may spend two to four months in the forest living at a *kumbo* hunting camp called *lihano*, and setting 10–20 *elongo* traps. They may bring their wives and children with them, but they must refrain from sexual intercourse until after an elephant is caught.

Besides the *elongo*, there are two other elephant traps, the *bolonga* and the *esongo*, which both make use of camouflaged pits (*lohoku*). Neither of these pit traps also called *lokombo-bahoku*, involves very refined technology or *bongala*. A fence is simply constructed to keep the elephants confined to the path (*busambi*), thereby forcing the animals toward the pit. In the *bolonga*, sharpened wooden spears are stuck in the bottom of the pit with their sharp ends up whereas in the *esongo* trap several steel-head spears are placed in the pit in a ring of steel. Branches are placed over the mouth of both the pits (*lihoku*) to camouflage them.

5. Bag Nets

The Ngandu use four types of bag nets. The hunters position the nets so that small rodents and monkeys run into them when trying to escape, but at the moment the animal enters, the hunters close the nets behind them. These nets must be watched. All four types of bag nets are looped of string which is made by twisting together strands of fiber from the bast of the *lokosa*. *Iteko* and *bopone* bag nets are brought along for the *lookwa* and *paho-ambwa* (hunting with dogs) hunts as well, and are set at holes in trees and at the exits of nests.

6. Others

The Ngandu hunters take advantage of the fact that the crested Guinea fowl often builds its nest among a grove of trees with several roots or stumps. After the crested Guinea fowl leaves its nest, the hunters build a cage of branches, with just one entrance the *kombelia* around it. When the crested Guinea fowl returns and enters the cage, the hunters either seal the entrance of the cage or set a type of spring trap called an *imote* bag at the entrance.

Children and elderly Ngandu use a simple hunting technique to catch small birds that come to drink at river banks. They cover the bark of trees which are partially submerged in river or which have fallen across the bank with *bokosa* or *lopote*, a sticky gum made from the sap of the *luna* tree (*Landolphia congolensis*) or the

bosenda tree (*Saba florida*), both of which belong to the Apocynaceae family. The resin of trees of *Landolphia comorensis*, which is the most common species of the *Landolphia* genus, is widely used as birdlime in tropical Africa (Irvine, 1961).

THE DISTRIBUTION OF MEAT

Animals taken in collective hunts are slaughtered at places (*eombo*)⁽²³⁾ where the hunters gather to rest after the hunt is over, typically near a river. Animals taken in individual hunts are usually brought back to the village by their captors without being butchered. When one man cannot transport the animal by himself, he returns empty-handed to the village to enlist the aid of helpers. They return to the kill, butcher the animal and each brings back a part. Before leaving the site of a kill to return to the village for help, the hunter usually marks the kill as his possession by making footprints on the ground in a circle around the animal (*bosile*; see also Note (17)). He may also sever a manageable portion of the animal to carry back to the village, thus indicating ownership. In the case of a large animal such as a yellow-backed duiker or bushpig that cannot be carried by one hunter, the kill is also marked as a personal belonging (*mene-tate*) by crumbling tree leaves over it. At the same time, the hunter performs some magical rituals over the kill so that it does not become the prey of other predacious forest animals.

Seesa, or the rough butchering of the catch carried out in the forest with knives or machetes for the purpose of distributing the meat, is done by men. The *seesa* operation involves removing the four legs from the torso, cutting out the backbone, severing the head and neck, and gutting the animal as well. Squeezing the contents from the intestines is also done by men.

Seesa carried out in the village is also the work of men. Animals taken by means of traps are usually butchered by the person who set the trap, although in *paho* hunting, people other than the person who killed the animal may butcher it. In *seesa* carried out in the village, the men use an axe to cut the backbone of the animal. Then the women take over; striking through the bones of the chunks of meat with a hatchet (such an act is called *keeka*) and cutting the meat into small pieces in preparation for cooking with knives (such an act is called *shika*). Women are also in charge of the cooking.

Fixed rules (*lihiko*) govern both the butchering of animals taken by means of collective hunting, whether conducted with or without the direction of a *nkanga* (hunting specialist), and the distribution of meat. The cuts of meat distributed first are called *eyali*. The exact contents of the *eyali* vary, depending on the importance of the role one plays in the collective hunt and on the type of animal taken. The *eyali* must be distributed not only to the person who brought down the animal or captured it in his net, but also to the *nkanga* hunting specialist who managed the hunt, the men who hurled the first and second spears (or arrows) into the animal, and the men who acted as the *boto-ambwa* and *liko* of the *botai* collective net-hunting or the *imbombo* beaters and the *ikocha* of the *bakimano* collective bow-and-arrow hunting.

The meat distributed to the person who butchers the animal (*boto-asesa*) as a fee for his services, as well as the meat distributed to those who simply show up at the place of butcher, is called *lotonya*. The particular portion of the animal to be

distributed in this way is left to the discretion of the person who caught or killed it.

Eyali or *lotonya* meat, given freely at the place of butcher to those who caught or killed nothing in the hunt, is called *einda*. *Eyali*, *lotonya* or *einda* meat brought back to the village and further distributed is called *likaho*.

In addition to the distribution of meat to those involved in the hunt and the butcher, there are additional stipulations, based on considerations of social solidarity, which require the distribution of meat to one's in-laws (e.g., *bokilo* and *bokana*), one's blood relatives, and to those of the same age as oneself (Takeda, 1984, 1991).

Meat from animals taken or trapped in individual hunts, while belonging essentially to the hunter himself, must nevertheless be distributed in accordance with socially accepted rules. Also, *bochungola*, or the man who discovers an animal caught in a trap and either informs the person who set the trap or brings the animal to that person, naturally has a part of the animal reserved for him, which he will receive as *eyali* from the owner of the trap.

I. The Distribution of Meat in Collective Bow-and-arrow Hunting, or *Bakimano*

The person who first shoots an animal with an arrow and hits it is called *lisenga*, the owner of that animal. If the animal escapes and is caught in the nets at the rear, the owner must give the *bohumba* portion of the animal to the person (*bototai*) in whose net it was finally caught. The *bohumba* portion, approximately equivalent to the bones and flesh (including the skin) of the back, contains the breastbone with the attached ribs and the meat adhering to it, so this usually includes the two thoracic vertebrae (*likuleelo*) connected to the cervical vertebrae and the front thoracic vertebrae of the lumbar vertebrae. Fleeing animals caught in the net, or animals which have not been hit by arrows, belong to the person in whose net they are caught. The *bototai* gives the *eyali* portion to the person who actually captures in front of his net an animal previously caught therein. The second person (*iyanda*) to assist in the capture of the animal in this way receives nothing.

The *eyali* for a *lisenga* hunter who first hits the animal with an arrow consists of the following parts of the animal: the meat and bones of both hind legs and the buttocks, the hipbones (*bolembe*) and the bones adhering thereto, *buusa*, the kidneys and liver of the animal, and the head (if the animal is a Peter's duiker, a black-fronted duiker, a female bushpig or a female buffalo).

In the case of a *nyaama-kolomo* animal, the portions are the same through the first four items in the previous list with the addition of the *bolombo*, *buuha* or *buuhala-lihimo* portion which is equivalent to the skin and meat of the belly, including part of the ribs. Butchering of *nyaama-kolomo* animals, however, involves cutting away from the breast, which severs part of the ribs with the belly.

The hunter who first discovers *nyaama-a-bed* antelopes, such as the yellow-backed duiker, the bay duiker, and the water chevrotain (which often lie down to rest in the forest during the day), is called *nzembela*. He either shoots his arrows at once or, if the animals appear ready to flee, alerts the rest of the hunting party by *iyoli* whistling, at which point the hunters try to surround the prey. If the rest of the hunting party, alerted by the sound of the *iyoli*, succeed in catching the animals, the *nzembela* receives the *eyali* portion ordinarily due to the *lisenga* or first archer

to hit the animal with his arrow. He receives the same four portions of the animal mentioned above, as well as the intestines and spleen. An archer hearing the *iyoli* and shooting the animal with his arrow, or a netter in whose net these fleeing animals are caught, are called *lisimbiya*. They are those who cooperate in the hunt as helpers, but are not entitled to receive any meat themselves as *eyali*.

These *lisimbiya* helpers receive the *loola-kingu* portion which contains the bones and meat of the front legs and the neck (minus the head), as *einda* from the *nzembela*. If two hunters shoot their arrows at the same time, these two share the *loola-kingu* portion.

Beaters (*imbombo*) play about the same role as the *liko* hunter in net-hunting. However unlike the *liko* hunter, they receive an *eyali* portion regardless of whether they are on the right or the left side. They receive one of the front limbs (*loo*) of the kill if it is a *nyaama-kolomo* animal or an antelope such as the Peter's duiker, black-fronted duiker, or blue duiker. They receive the *bohumba* portion if it is a *nyaama-a-bed* antelope, bushpig, buffalo, or monkey.

The *eyali* due to the *ikocha* archer positioned just inside the *imbombo* beaters comprises the *lisolo-looloko* portion with the heart and lungs still attached, of the blue duiker, *nyaama-kolomo* animals or monkeys; and the *iseke* portion, which contains the meat of the last of the thoracic vertebrae connected to the lumbar vertebrae, of the bay duiker, Peter's duiker, black-fronted duiker or water chevrotain; or the *losyua* (plural: *jyosyua*) portion, which contains the layer of muscles of the armpit where the front leg meets the torso, of the yellow-backed duiker, bushpig, or buffalo.

If a hunter shoots an animal which then escapes but is taken by someone else, he is the *lisenga* archer and no problem arises provided that he blows his *iyoli*, whistling to alert the rest of the hunting party. If, however, he remains silent (*biisa*), he can receive no *eyali* meat, as the *eyali* portion goes to the person who finally takes the animal. The *lisenga* archer receives one of the front limbs if the animal is a *nyaama-a-bed* antelope, bushpig, or buffalo; the *bohumba* portion if it is a blue duiker, Peter's duiker, or *nyaama-kolomo* animal, one of the legs (*lokolo*) if a bird; together with the *kingu* or neck portion, which in the case of snakes is taken to mean the narrow section between the head and the rest of the body.

The *eyali* of a *nkanga-lusala* who directs a collective bow-and-arrow hunt, also differs depending on the species of animal taken. His *eyali* consists of the *loola-kingu* if the animal is a blue duiker. If the animal is a Peter's duiker or black-fronted duiker, his *eyali* is the *loola-kingu* which, in the case of a male animal, is augmented by the head and the *lisolo-looloko*. In the case of a *nyaama-a-bed* antelope, he receives the head, one of the front legs, the *lisolo-looloko* and the *lihimo*. In the case of bushpigs and buffalo, he receives the *loola-kingu*, the head if it is a male, the *chungu* (meat of the buttocks excluding the hipbone), the breasts or nipples (*iyoka*; plural, *toka*) of the bushpig, part of the liver, part of the stomach, and part of the ribs (*lohanje*; plural, *panje*). If the catch is a *nyaama-kolomo* animal, the *nkanga-lusala* receives the head and neck; if monkeys, he receives the head, one of the hind legs, and the tail (*bokali*). In the case of birds, the *nkanga-lusala* receives either the *lisoko* (the wings and that part of the wing half torn away from the torso) or one of the legs. Small rodents (*poo*), because they are so small, belong to the hunter who catches them; it is not necessary to share them with the *nkanga-lusala*, nor even to inform him of a catch. A terrestrial tortoise (*eulu*), if only one is caught, goes to the *nkanga-lusala*;

if more than one, the *nkanga-lusala* gets the first and the rest go to the hunter who found them. In the case of snakes—specifically, the Gaboon viper (*lichulambwa*) and python (*nkuma*)—the *nkanga-lusala*'s *eyali* meat is the head, one slice of the body (cut in a cross-section, not down the length), and the tail (*iyongo* or *losolongo*). In the case of a python taken by a single individual, however, the skin is not cut in sections but stripped off whole, dried, and either sold or bartered. The rhinoceros viper (*mpele*) is *boto-looto* which means “to each his own,” so distribution varies with the entire catch going to the *nkanga-lusala* at times, or some of it going to the person who discovered it at other times. In the case of other snakes, the *nkanga-lusala* may receive nothing, but the hunters are obliged to inform him that they have caught something; they must not keep silent (*biisa*).

The *eyali* meat, with respect to the capture of an *ikoloaki* (a pygmy elephant) in a *bakimano* hunt, is distributed in the following manner: the *nkanga-lusala* receives the *loola-kingu*, the head, part of the intestines, the *lisolo-looloko*, part of the trunk, and the *boseko*. The *boseko* portion is the top layer of muscles along the side of the neck running from the nape to the shoulder, including the skin. When dissecting *nyaama-kolomo* animals, this *boseko* section is initially cut into left and right halves and removed from the body. In the past only men ate this portion because of the *bilamu* taste (i.e., laced with fat and therefore delicious), but today women and children may eat it, too. The *lisenga* archer receives both hind legs, the spleen, the diaphragm, part of the intestines, the kidneys, the liver, and part of the trunk. The *imbombo* beaters receives one of the front legs. The *ikocha* archers, who are positioned just near the *imbombo* beaters, receive one of the *losyua* portion.

II. The Distribution of Meat in Net-hunting, or *Botai*

The *eyali* of the *nkangotai* who directs a net-hunt, is the neck in the case of the blue duiker. In the case of the Peter's duiker, black-fronted duiker, bay duiker and yellow-backed duiker, the *nkangotai*'s *eyali* meat is one front leg, the head (with the bay duiker and yellow-backed duiker he receives this whether the animal is male or female; with the Peter's duiker and black-fronted duiker he receives this only if the animal is male), the *lisolo-looloko*, the *iseke*, the lower half of the *lihimo* portion which contains the skin and meat of the belly including, if the animal is a male, the scrotum (*lokunjua*) and penis (*nsoka*), or if the animal is female, the breasts or nipples (*eele*) and the neck of both male and female. If the animal is a water chevrotain, he receives the head, one of the front legs, and the *lisolo-looloko*. If the animal is a bushpig or a buffalo, he receives one of the hind legs, the head of the male, the stomach, the *chungu*, the *lisolo-looloko*, the spleen, and part of the intestines. In the case of a *nyaama-kolomo* animal, he receives the head, one of the hind legs, and the *lihimo*. *Poo* rodents are too small to be shared and so belong to the one who catches them, who may or may not inform the *nkangotai* of his catch. If a bird is caught in the hunt, the bird's wing belongs to the *nkangotai*'s *eyali* meat. If an *eulu* land tortoise, Gaboon viper or python is caught, the *nkangotai* takes all. As in the case of the *nkanga-lusala*, there is no obligation to share other snakes taken in the hunt, but one must inform the *nkangotai* of the catch in the hunt.

Animals taken in the net, whether killed by the owner of the net (*bototai*) or by

someone else, belong to the owner of the net, who has the same rights to receive meat as the *lisenga* first archer. The *bototai's eyali* consists of the *lisenga* portion, the *buusa*, the liver, the kidneys, the *buuha* portion (which contains the bones, meat and skin of the breast, including part of the ribs and cervical vertebrae), the head (of the male Peter's duiker and bay duiker only), two *boseko* portions, the *chungu*, stomach, and intestines. However, the *chungu*, stomach and intestines of the bushpig and buffalo, are the *eyali* of the *nkangotai*.

The *liko* hunters who are positioned at either end of the *elonga* net-fence and play an important role preventing the animals from fleeing, have an *eyali* claim on those animals captured on the sides of the net (on the left or right side) to which they belong. The *eyali* is different for the two sides.

As *eyali*, the *liko* receive the entire *lihimo* if the catch is a blue duiker, the *liyomo* portion [which is the upper half of the neck (*kingu*) including the trachea (*bohoho*) and esophagus (*bohoho-ba-toma*)] of *nyaama-a-bed* antelopes and Peter's duiker, and the *bosenge* portion (which contains the skin and meat of the side of the chest or flank i.e., both sides of the *lihimo*) of the bushpig and buffalo. They receive no *eyali* if *nyaama-kolomo* animals, birds or other animals are caught in the hunt.

Bototai are responsible for their own nets and like the *lisenga*, first archer, have the right to receive *eyali* portions from animals caught in them.

However, it sometimes happens that someone else, perhaps assisted by yet another person, kills an animal caught in the net of the *bototai* a little ahead of him. The first person to act in killing the animal is then the *bohumba* hunter (the one who helps by first spearing the animal) while the second hunter to assist becomes the *iyanda* (the one who helps by spearing the animal a second time). Each of these men gets *eyali* from the *bototai* in whose net the animal was caught. If a third person spears the animal he gets nothing. If the animal is a Peter's duiker or a black-fronted duiker, the *bohumba* hunter gets the *bohumba* portion (which is approximately equivalent to the bones and flesh of the back) and the *iyanda* hunter gets the upper half of the *lihimo* as *eyali*. The blue duiker, because it is a small antelope, can be grabbed bare-handed; even so, those who merely run to the net in which it is caught to help take it can have the *bohumba* portion as *eyali*. In this case an *iyanda* or second hunter if present, gets no *eyali*. In the case of the *nyaama-a-bed antelope*, the *bohumba* hunter can have the *bohumba* portion and the *iyanda* can have the *likuleelo* portion (which contains the bones and meat of the two thoracic vertebrae connected to the cervical vertebrae including the attached ribs), part of the lungs (*lisolo*), the diaphragm, part of the intestines, the *lambo-la-lokolo* portion (which contains the top layer of muscles and skin where the hind legs are joined to the torso at the belly, corresponding to the *losyua* of the front leg), and the *litombo* which is equivalent to part of the *buuha* breast. When bushpigs or buffalo are caught, the *bohumba* hunter receives the *buusa*, the neck of the bushpig, one of the front legs, and the heart, while the *iyanda* gets the ribs. In the case of monkeys, the *bohumba* hunter gets the *bohumba* portion. In the case of snakes, such as the Gaboon viper and the python, he can have the *kingu*. Distribution of the rhinoceros viper depends on the *nkangotai's* generosity (*boto-looto*); if the *bohumba* hunter gets anything from the *nkangotai* it is the *kingu* or a cross-sectional slice of the body. Neither the *bohumba* hunter nor the *iyanda* gets any *eyali* from birds, *nyaama-kolomo* animals or other animals.

The *eyali* due a *boto-ambwa* (one who brings dogs to the hunt) consists of one of the front legs in the case of the blue duiker, bushpig, and *nyaama-kolomo* animals; with *nyaama-a-bed* antelopes, he can have the *loola-kingu*. He receives no *eyali* from catches of birds, snakes, and tortoises.

III. The Distribution of Meat in *Bohonda* Net Hunting

The *nkangohonda* eats no meat of the bushpig, of course, nor of such antelope as the yellow-backed duiker, black-fronted duiker, sitatunga and bongo. However, the *eyali* due him as the leader of the hunt must instead be handed over to the family of the *nkangohonda* and the people of his village whenever these animals are taken in the hunt. The *nkangohonda's eyali* also varies depending on the species of animal caught in the hunt which he directs.

In the case of the bushpig, he can have the *lisenga* portion, one of the ribs on the right side of the rib cage, the *lisolo-looloko*, the stomach, the tongue (*lolemu*), the *chungu*, the head of the animal if it is male, the tail, and the *lisungu*. The *lisungu* portion is the tip of the front leg. It is equivalent to the foot, and like the elephant's *lichinji* (the ankle of the hind leg), it is considered to be *bitamu* or fatty and delicious to the taste and so is one of the parts the Ngandu like best. In the case of buffalo and bongo, the *eyali* consists of the *lisenga* portion, the *lisolo-looloko*, the stomach, the *chungu*, the *lihimo*, and the head. In the case of a bay duiker, yellow-backed duiker, or Peter's duiker, the entire animal goes to the *nkangohonda*. However, should a Peter's duiker or bay duiker be caught together with a bushpig, if the *botohonda* demands the meat of the Peter's duiker or bay duiker instead of that of the bushpig, he then can have meat from the bay duiker or Peter's duiker only after meat has been distributed to the first three *botohonda* who have a claim on it. These *botohonda*, however, then lose their right to get the meat of the bushpig instead. If a black-fronted duiker is caught in the net it must not be killed. Instead the animal must have its ears clipped and then be released. The blue duiker, tortoise or all birds caught in the hunt go to the *nkangohonda*. As in the case of the *nkanga-lusala* and *nkangotai*, the *nkangohonda* must give a person who catches a Gaboon viper or python the *kingu*, a cross-sectional slice of the body, and the tail as *eyali* portion. All other snakes belong to the *nkangohonda*, so a person catching one of these other snakes in the hunt is obliged to inform the *nkangohonda*.

The *eyali* of the *botohonda* in whose net a bushpig is caught (equivalent to that of the *lisenga* hunter in a *bakimano* hunt) consists of the *lingongo* (which is equivalent to the bones, meat, and skin of both front legs, the head, and the neck), the intestines, the *lihimo*, the kidneys, one of the *lisungu*, the liver, the *bokongo* portion (which includes the entire backbone or spine, specifically the bones and flesh minus the ribs), and the head if it is a female.

The *boluka*, who scout ahead for herds of bushpigs, can have an *eyali* portion if three or more bushpigs are taken. In that case, their *eyali* consists of the *lisenga* portion, the *lisungu*, and one rib each, though they get the tongues of every bushpig which they themselves catch. If seven or more bushpigs are caught, the *boluka* can have the *lisenga* portion, the *lisungu*, and three ribs each, as well as the tongues of those bushpigs they themselves catch in the hunt.

A man who helps kill an animal at a net other than his own by being the first

(*panga*) to thrust a spear into it gets the *bokongo*; the second man (*koeola*) to help in this way gets the left side of the rib cage.

IV. The Distribution of Meat in *Botoke* or Monkey Hunting

A hunter who brings a net to the hunt, the *bototai*, receives the head, one leg, the *bolembe* portion (which contains the hipbone without the *chungu* or the meat of the buttocks) and the *lihimo* of any monkeys killed in his net.

However, a hunter who aids the *bototai* in the kill gets the head as his *eyali*; a second helper, if there is one, gets the *bohumba* portion.

The man who first cuts or stabs a monkey that has come down from the trees gets the head of that monkey; the second person in the attack can have the *bohumba* portion.

Those whose task is to climb the trees and get the monkeys to the ground receive the *buusa* of only those monkeys they themselves catch. Those who have brought dogs similarly receive one of the arms of only those monkeys they themselves assist in taking.

A leg from each monkey taken is given to the hunter who first discovers a monkey or a troop of monkeys and informs the rest of the hunting party, even if that person takes no direct part in their seizure.

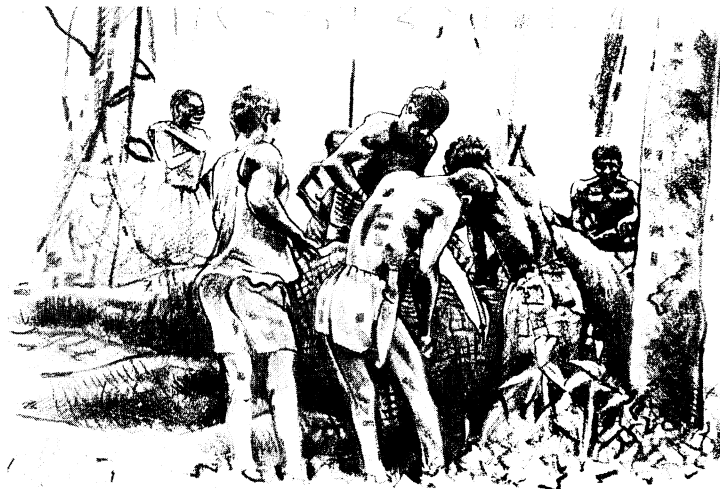

Fig.10. Butchering of a male elephant trapped in *elongo* (sketch drawn by Mr. Seiichiro Nakamura, painter in Amakusa, Kumamoto, Japan, based on a photo taken in 1976 by the author).

V. The Distribution of Meat in *Paho-ambwa* Hunting with Dogs

If two men go on a *lookwa* hunt (hunting of small ground-dwelling animals) the one who brings the dogs (this person is the *mene-ambwa*) receives as his *eyali* portion the *lisenga* portion, the *buusa*, the *chungu*, one of the front legs, the head, the *lihimo*, the kidneys and liver of any animals they may catch.

A person without dogs occupies a position similar to that of the *lisimbiya* helper in a *bakimano* hunt; his *eyali* consists of the *loola-kingu*, the *bohumba* portion, and the *buuha*. If he is the one who dissects the animal after it has been caught and killed he also receives the *lotonya* portion for this service. This *lotonya* consists of the *lisolo-looloko*, the intestines as in the *likunju-limbombo* portion (which includes the main stomach itself or *likunju* together with the part of the stomach [*imbombo*] where it is connected to the esophagus), the *linene* portion (part of the muscles adhering to the *chungu*), the *bosenge*, the *lambo-la-lokolo* and the *isambu* (part of the *linene*).

If the *lookwa* is conducted by three people, the *mene-ambwa* receives the *lokolo-lolembe* portion (which is equivalent to one of the hind legs and the meat and bones of the hipbone: if both hind legs are included this portion becomes the *lisenga* portion), the head, the neck, the liver, the kidneys, and the *buuha* of any animals caught. One of the other two persons receives one of the hind legs, the *buusa*, and half of one of the front legs; the other receives one of the front legs, the *bohumba* portion, and half of the other front leg. Beside these *eyali* portions, the intestines, stomach, and *lisolo-looloko* are given to the hunter as *lotonya* for the butchering service if he butchers the animals.

VI. The Distribution of Elephant Meat in *Elongo* Trapping

When elephants are speared by the *elongo* trap they do not die immediately. The place where it finally does fall becomes the place of slaughter (*lisaki-la-njou*) (Fig. 10). The elephant meat is boiled and then placed on a wooden shelf (*boliko*) built nearby and dried by a fire underneath. Thereafter the meat is stored on another *boliko* shelf in the house and consumed little by little (Takeda, 1984, 1990). Usually, the butchering is carried out not only by the *nkangongala* who directs *elongo* traps and the two *ekoho* assistants, but also by relatives of both sexes. Before butchering, as mentioned above, the *nkangongala* cuts off the tip (*ikasa*) of the trunk, buries it nearby and places hunting medicine connected with the *bongala* rituals on the elephant. The people gather in front of the elephant to beat their *likese* (wooden clappers) and sing. Then, the *nkangongala* inserts two of these *likese* into the dead elephant's anus and two more into its mouth. The butchering of an elephant involves not only the removal of just the *chungu* from the hipbone, but also the removal of a portion that corresponds to the *chungu* from the hind legs. The skin of the elephant, unlike the skin of other animals, is not consumed because of its hardness, and is therefore abandoned at the slaughtering place. However, the end of the tail with thick black hairs is cut off and stored for another use (see also *bokalu* in Appendix 2).

The *nkangongala's eyali* consists of both hind legs, the neck, the *bonyuwa-lisoko* portion which is the equivalent of the *chungu*, one front leg, both tusks (*bopati*), the

kidneys, part of the intestines, part of the *lisolo-looloko*, part of the liver, part of the trunk, the tongue, part of the brain (*boongo*), one *boseke*, and the *pungu-soho* portion (which usually means just the large intestine, but on occasion includes also the stomach), the colon, small intestine and rectum which are collectively called *besoho* (singular; *bosoho*). Although, as mentioned above, it is a food taboo for the *nkangongala* to eat either the brain or the eyeballs of the elephant, he nevertheless receives the brain as *eyali*, which may later be given to others.

The two *ekoho* assistants receive a front leg, two of the muscles along the backbone (*kalangu*), one *bonyuwa-lisoko*, part of the intestines, part of the liver, part of the *lisolo-looloko*, one *boseko*, part of the brain, and both eyeballs.

The first wife (*boliko-anyaaiki*) of the *nkangongala* receives the *kingu* as her *eyali* meat. The *nkangongala*'s second wife (*lokoli-lolimba*) — provided he has one — can have the meat of that part of the backbone which is not connected to the ribs, called the *buusa*.

Those helping with the work of dissecting the elephant can have the remaining meat as their *lotonya* for the butchering service.

VII. The Distribution of Meat in Trapping in General and in Other Hunting Methods

Animals caught in traps are usually collected by the hunter who set the traps as he goes around checking them, so these animals are his. In spring traps, the mainspring or support (*sumbe*) of the trap is usually left in place and only the binding ring (*lisili*) that directly closes on the animal is brought back to the village with the animal. Occasionally, a passer-by who notices a small or medium-sized animal caught in a trap, will either bring the animal back to the person who set the trap or, as most animals are slaughtered near rivers, carry the animal to the riverside and then go to inform the trapper. If the trapped animal is a large one, or if the trap is in a remote area, the discoverer will inform the trapper of his catch verbally, without carrying it anywhere. In either case, this person, called a *bochungola* (which corresponds to the Lingala word *kolungola* which means to remove) will receive an *eyali* meat of one of the front legs of the animal from the trapper.

When someone discovers an animal by chance which he then catches, or notices a *liseko* (the alarm calls uttered by small rodents) leading to a catch, the animal belongs essentially to him. If accompanied, he must give the animal's neck to those people who are with him. If the animal is a blue duiker or Peter's duiker, they get the neck and one of the front legs, if a snake they get a *likaho* portion of the neck and a cross-sectional portion. These portions are not prescribed by custom and so are not *eyali* but *likaho*, a kind of donation freely given by the person who catches the animal.

Kinship affects the distribution of meat, particularly in the context of relationships traced through marriage on the mother's side. If a mother's brother or *nyango-paami*⁽²⁴⁾ catches an animal, he must give his *kaali* or sister's child the *buuha* portion of the kill when he returns to the village or temporary forest hamlet. Conversely, when a *kaali* (mostly male children of the sister) catches some animal, he must give the *lihimo* portion to his mother's brother or *nyango-paami*. If the animal happens to be an elephant, however, the portion that must be given as the *eyali* is neither

the *buuha* nor *lihimo* but one of the *lichinji* portions which includes the ankle of the hind leg of the elephant.

Bokana is the general term for relationships formed between the children of one's father's brothers, the children of one's mother's sisters, and grandparents and grandchildren. It is rare for women to participate in hunting although girls may act as beaters in the *bakimano* hunt (collective bow-and-arrow hunting) when there is a shortage of helpers. But otherwise there are few occasions when men receive meat from women via the *bokana* relationship, so it is the animals caught by men that are subject to social customs (*lihiko*); the stomachs of animals caught by any of these men must be given to those *bokana* who happen to be present.

In relations between *nyango-paami* and *kaali* or between *bokana* and *bokana*, the meat of animals of the size of *nyaama-kolomo* animals or blue duiker are not subject to distribution; the Peter's duiker is the smallest of the antelopes for which such distribution of meat is required. Moreover, a single distribution of meat does not suffice for these relationships, but meat must be shared whenever these relations or any of their lineage (*losombo*) are present on a successful hunt. For example, if the lineage of person A is the lineage of his mother, and the lineage of person B is the lineage of someone else, and if these lineages are in a relationship of *nyango-paami* and *kaali*, a due portion of meat must be given between A and B, too. Moreover, if these same people are *bokana* as well as *nyango-paami*, then the portions of meat due to both relationships must be distributed.

Bokilo relationships which arise through marriage also require the presentation of meat. This kind of distribution is a *lihiko* custom—i.e., a rule, stipulated or required—it does not constitute an *eyali*. *Bokilo* relationships are those in which dowry and bride price items are exchanged⁽²⁵⁾ (see also Takeda, 1991, and Note (26)). They arise between persons of the opposite sex, as for example, between one's brother's wife and oneself (if one is a male) and one's sister's husband and oneself (if one is a female), and also between persons of the same sex,⁽²⁶⁾ for example, between a father-in-law and his son-in-law (Takeda, 1991). If a person catches an animal, and another person who is that man's *bokilo* is there or is just passing by, the latter can demand of the former the *chungu-solosolo* (the buttocks of the animal minus the *linene* portion (which is part of the muscles adhering to the *chungu* buttocks), one front leg, and both kidneys of the animal. This applies to all animals taken in the hunt, although if an elephant is caught, the *bokilo* may ask only for one of the hind legs.

Another type of exchange different from the relations stated above exists between those of the same age (*indongo-moko*) (Takeda, 1991). The distribution of meat among this group is not so much *eyali* as it is a social *lihiko* custom. Among the Ngandu, those born in a given year (though it is not always the same year) are called *lotoelo*, or more commonly, *indongo* in Mongo. For example, *indongo* born in the years 1933–35 are called *kake-na-benja*; *indongo* born in the years 1936–37 are called *bomalinapopo*. Those of the same *indongo* render each other mutual aid and assistance. If a man catches an animal, and if one of his *indongo* is with him, then that man will give his *indongo* the *buuha* portion of the animal (which contains the bones, meat and skin of the breast); if there is a second *indongo* with him, he gives this second *indongo* one of the hind legs of the animal. In the case of an elephant he must give his *indongo* one *lichinji* portion of the hind legs.

DISCUSSION

Hunters in the tropical rain forest, like those in the open savanna or wooded savanna where visibility is good, need to rely on sight, on direct discovery and on tracking the visible signs of the prey animal's presence such as its form, footprints, faeces, or territory markings. However, the forest is a natural environment that limits the hunter's vision and interferes with his ability to discover the prey animal.

There are many instances in which the hunter of the forest must rely on his sense of hearing in order to stalk an animal he cannot see; he must hear the animal's cries, the faint sound of its footfalls over the fallen leaves that carpet the forest floor, or on the equally slight sounds it makes as it feeds on leaves and grass. No doubt this condition was one thing that spurred the development of collective hunting, in which unspecified numbers of unseen animals are driven to their capture. The tropical rain forest has an abundance of plant and animal life. Given this fact, it is interesting to compare the hunting techniques of the Ngandu with those of the hunter-gatherer Bambuti Pygmies who inhabit the Ituri Forest in the tropical rain forests of northeastern Zaïre.

The primary vegetation of the Ituri Forest, which is the transitional ecotone zone between a tropical rain forest and a woodland savanna (Itani, 1984) is predominantly the Caesalpinioideae trees such as genera of *Brachystegia*, *Julbernardia* and *Isobertinia*. The Ngandu use all the same techniques as the Bambuti Pygmies, but they have also developed a rich trapping technology as well. The development of effective trapping techniques is a common and widespread result of an agricultural people who, unlike mobile hunter-gatherers, have to stay in one more or less restricted area to grow their crops. However, in the Ngandu case development of traps may be the result of a major difference in subsistence strategies between the Bambuti Pygmies and the Ngandu. Namely, the Bambuti Pygmies' subsistence relies greatly on the socio-economic symbiosis with the agriculturalists around them: they barter the meat from the animals they hunt for the cassava, bananas and other agricultural products cultivated by the agricultural peoples living nearby (Ichikawa, 1976). Ngandu, by contrast are virtually self-sufficient in food and have had to develop strategies for both hunting and horticultural subsistence. The wide range and rich variety of foods which are characteristic of the Ngandu diet (a diet also quite rich in animal protein; Takeda & Sato, 1993, 1996), is hedged about by dietary restrictions based on sex and age; nevertheless there seems to be a positive attitude, a willingness, to make use of the supply of game available to them, which itself no doubt provided a large impetus for the development of a sophisticated trapping technology (Takeda, 1984, 1990).

Herskovits (1926) discusses hunting guilds, and the ascendancy of hunting connected with the remarkable hunting rituals that characterize Congo cultures. Such hunting guilds developed around "magician specialists" who appear to be equivalent to the sorcerer-like hunter specialists called *nkanga* by the Ngandu. Such magician specialists are also known to exist among the Bemba of northeast Zambia (Richards, 1969) who inhabit a very different natural environment (i.e., open lands). This account of the hunting of the Ngandu suggests that the hunting rituals and cultural systems surrounding hunting increase in complexity as one moves west from Lake Leopold to the forests settled by the Bantu-speaking peoples.

NOTES

- (0) The identification of plants in the text is based on the flora list compiled by R. Asato, T. Kano, S. Kuroda, S. Uehara, J. Takeda, G. Itani and M. Mbangi (unpublished) and on Idani et al. (1994), although there are some local variations in the plant names used and spoken at Bowa in Ikela Zone and at Wamba in Djolu Zone, even among the Ngandu people.
- (1) *Beengo* is the collection of either the root stalks of the cassava or the stems of cassava seedlings for the purpose of creating new fields, obtained either by cash purchase, through barter, or as a gift. The woman who manages the fields decides whether to buy or to barter.
- (2) The word *paho* is also used for *puha-nse* fishing, a term for the raking up of river fish with baskets or vessels by women and children (Takeda, 1987, 1990).
- (3) The *bohonda*, a net-hunt for bushpigs conducted by a *nkangohonda* (a bushpig charmer) is no longer done. It was last carried out in 1959.
- (4) *Buusa* refer to the lumbar vertebrae and the meat adhering thereto (i.e. the meat and bones of the lower back). Some of the names the Ngandu give the various cuts of meat pertain only to a particular ligament or bone, but usually these names refer also to the bones, meat and skin sections cut from the animal as a whole.
- (5) The *bokungu* tree (*Piptadeniastrum africanum*) is also used to expedite successful hunting. When someone shoots at an animal but fails to bring it down, he thrusts this tree into the ground in the expectation of better hunting the next time.
- (6) Slapping the fist of the left hand with the palm of the right hand is an action the Ngandu use when indicating an abundance of something.
- (7) The *elonja* is a flat, pipe-shaped musical instrument, played by striking it with the hand at the same time as beating time by alternately touching the open end of the instrument to the thigh and removing it again.
- (8) Poisoned arrows are made as follows: *lolengo* (*Parquetina nigrescens*) sap, *lilanga* (*Crinum jugus*), *kafo* (*Pentadisplandra brazzeana*), and red pepper (*Capsicum frutescens*) are ground in a mortar made of *bokakate* (*Morinda lucida*). The arrowhead is then dipped into the liquid extracted from this mixture by means of a kind of juicer (*lounjya*). The Bambuti Pygmies also use *lolengo* sap as a poison for their arrows, such poisoned arrows being used chiefly for hunting monkeys (Harako, 1977, 1981).
- (9) *Lokosa* vine (*Manniophyton fulvum*, Euphorbiaceae) is one of the most important materials collected by the net-hunters of the Bambuti Pygmies in the Ituri Forest (Tanno, 1977), and it is universally grown in the tropical rain forest in Zaïre. The Ngandu also take the inner bark, shave fibers from this plant, and loop them into string to make nets (see *botai* hunting), *tombi* or *tombi-otai* shoulder bags (see also Note (15)) carried in hunting and in daily life, fishing hand-nets for fishing in rivers (*lisangi*; used by women), and bag-nets for fishing (*liheta*; used by men) (Takeda, 1987, 1990). The men carry out the work of making these nets, from gathering the bark to shaving the fibers, looping them into string, and then looping the nets from the string.
- (10) The *lolohili* tree (*Afrostryax kamerunensis*) is also put in the horn for the *nkangalusalu* (the *nkanga* specialist for the collective bow-and-arrow hunt).
- (11) *Lokule* (wooden drums), *bopati* (elephant tusk flutes), *chichi* (gourd flutes) and *ihonge* (hand flutes) are also used to produce coded messages by modulating the sound and tone (*nkombona-lokule*), in order to alert the rest of the hunting party. A certain modulation is assigned to each kind of animal and its characteristic movement, thus constituting a type of code expressed in the Bosaka language:
- [1] *boloko* (blue duiker): *bokolobokoyoto* (meaning an intelligent animal or an old man or woman)
- [2] *mbengela* (Peter's duiker): *bohala* (Bosaka language meaning Peter's duiker)
- [3] *kuluha* (bay duiker): *bombende* (Bosaka language meaning bay duiker)

- [4] *mbende* (yellow-backed duiker): *lisokolasokolakibekili* (meaning “to walk about or range widely”); *lisoko* meaning yellow-backed duiker in the Bosaka language)
- [5] *iiiko* (brush-tailed porcupine): *iiiko-a-litakalaka* (meaning “fruit of the tree”)
- [6] *ekanda* (dark mongoose): *botongo-o-panja* (meaning “to move in a herd”; *epanja* meaning dark mongoose in the Bosaka language)
- [7] *buunju* (marsh mongoose): *buunju-a-akikilakiki* (*likiki* meaning “the specific smell of the mongoose”)
- [8] *mbolo* (forest buffalo): *bokanakanabambolo-a-kanakolo-nkotinelina* (meaning “to fill oneself with anger”)
- [9] *njou* (elephant): *bombongobolukanjou* (meaning “to walk all over the fields and forest”; *lohoko* meaning elephants’ paths in the Bosaka language while *busambi* in the Ngandu words)
- [10] *nkoi* (leopard), *lowa* (golden cat), *simba* (genet), and *yoo* (African civet): *bokoikoi-bohalangelika-sambeke* (meaning unspecified)
- [11] *nkema* (monkeys); *bohuluhulu-bolumiya-kema* (meaning “to excel at walking among the tree tops”)
- (12) Such a circle spatially surrounded by the hunting party is called *elonga*, just as in *botai* net-hunting or in any other net-hunting which actually forms an almost circular enclosure of nets strung together.
- (13) The currency of the Republic of Zaïre is the zaïre. One zaïre equals 100 makuta (lower monetary unit of Zaïre), equivalent to US\$ 0.05 at 1975 rates of exchange.
- (14) This *elembe* spear is not a *poo* spear. The shaft of the *poo* type is sheathed in copper and it is included in the bridewealth given to the bride’s people by the groom’s on marriage.
- (15) The *tombi-otai*, shoulder bag used by men, is made of looped *lokosa* string (*Manniophyton fulvum*, Euphorbiaceae) (see also Note (9)). It is also used to hold and transport animals caught in the hunt. The *tombi-otai* (also called *tombi-ya-baango*) is made of a finer mesh than *tombi* shoulder bags used in daily life. Formerly, a pelt packed in *losondo* (a mixture specially made for *botai* net hunts) was put inside this *tombi-otai* used in the hunting, which was then carried as an amulet or proof (*likoko*) against danger and misfortune (e.g., to ward off hunger and danger on the way) (Takeda, 1991). *Boote*, or medicine for the *botai* net-hunting, was placed in the *tombi-otai* and on top of the *boote* was placed a *baango* (one type of copper band). *Boote* medicine is made by combining bark shavings from seven different trees with gum-like clumps of roots found in soil where a species of mushroom called *lolungolu* (unidentified) grows. These seven trees are:
- [1] *likoko* (*Antiaris welwitschii*)
- [2] *bosenge-ya-jamba* (*Uapaca guineensis*)
- [3] *botongo* (*Xylopia phloiodoru*)
- [4] *itoto* (*Omphalocarpum injeloense*)
- [5] *bosemu* (*Chytranthus carneus*)
- [6] *lihomahoma* (*Trichlisia dictyophylla*)
- [7] *bombende* (*Artabotrys thomsonii*)
- (16) *Euki* is a mixture of banana skins (*Musa* spp.), the stems and leaves of *liloko*, a riverine herb (*Ranalisma humile*), and the male spadix of the oil palm (*Elaeis guineensis*) which is burned to ash and used for salt (Takeda, 1987, 1990).
- (17) Other *buune* signs to help one find one’s way and to inform those coming behind are made by dragging one’s foot across the ground to leave a long footprint (*buluchuchu*), or simply by leaving single footprints at key points on the ground (*bosile*). *Buune* made by breaking twigs and branches or leaves are also used to indicate personal possession (*mene-tate*). For

- example, one might mark a tree with a beehive one has found with a *buune*. A person found violating someone else's *buune* will be judged by the local council (*losambo*) and subject to various kinds of punishment (*etumbo*) (Takeda, 1991).
- (18) The Bambuti Pygmies train puppies to be hunting dogs by injecting juice from the leaves of Loganiaceae trees (*Strychnos* sp.) into their nostrils as a stimulant (Harako, 1977, 1981), but apparently the Ngandu do not use this method either to give the dogs the courage to face wild animals or to train them to be hunters.
 - (19) In the past *ichuwa* tree resin was also used for light. The cultivation of *ichuwa*, along with coffee and oil palms was promoted for cash crops during the period of Belgian colonial rule (Takeda, 1990).
 - (20) The Tongwe living in the wooded savannas of western Tanzania are a Bantu people who practice slash-and-burn agriculture and excel at hunting with guns (Nishida, 1973; Kakeya, 1974; Itani, 1977b; Takeda, 1984, 1992). They conduct big game hunts using a variety of muskets and homemade bullets.
 - (21) Most of the cassava cultivated by the Ngandu is the bitter cassava containing large concentrations of cyanic acid (Takeda, 1987, 1990). While bitter cassava crop yields are large, the cassava must be soaked in water for 3–4 days and be pounded to detoxify it. Elephants, however, can and do eat it raw.
 - (22) The Ngandu are polygamous. Wealthy Ngandu may have several wives, but the vast majority of men dislike both the discord (*luwa*; plural, *buwua*) common between wives, and the burden of bridewealth, and so have only one wife. As the first wife is generally called *booli-angolu* and the second and all subsequent wives are called *booli-anbuusa*, the names for the first or second wife of the *nkangongala* are specially entitled ones. Consent-based levirate (*lisango*) is generally recognized in the Ngandu (Takeda, 1991).
 - (23) *Eombo-likulo* (meaning “the gathering place at dusk”) or *eombo-a-shesa-nyaama* (meaning “the gathering place where the catch is butchered”). The initial meeting place of a collective hunt is called *eombo-kulu*, “the morning gathering place.”
 - (24) Maes (1934) emphasizes the importance of the political and social organizational functions of *nyango-paami* and *kaali* relationships among the Boyela (refer to Sato, 1983 for the ecological anthropological aspects of the Boyela), who are another Mongo tribe like the Ngandu. However, he limits *kaali* to the male children of sisters, whereas with Ngandu kinship terminology *kaali* includes sisters' children of either sex (Takeda, 1991).
 - (25) An exchange of goods (*bosolo*) takes place on the occasion of a marriage among the Ngandu. Bridewealth paid by the groom's family to the bride's is called *ngando* or *yelo*, while dowry from the bride's family to the groom's is called *lisongo*. This exchange of goods and money is not a one-time affair but continues for as long as the two are married. Also, those belonging to the bride's lineage are entitled to receive goods and money from members of the groom's lineage; the reverse is also true (Takeda, 1991).
 - (26) The relationship between ego (male) and sisters' husbands, and between ego (female) and brothers' wives, is called *bokoi*. Male ego's older brother's wife is called ego's *booli* (wife); female ego's older sister's husband is called ego's *boome* (husband). None of these relationships is an avoidance relationship as is the case in relationships of the opposite-sex *bokilo* (Takeda, 1991).

ACKNOWLEDGMENTS This research was financially supported by a grant under the International Scientific Research Program of the Japanese Ministry of Education, Science, and Culture (#7532 of 1975 and #7733 of 1977). I am greatly indebted to the CRSN (Centre de Recherche en Sciences Naturelles) of Zaïre, under whose auspices I carried out the field study in Zaïre.

I wish to express my gratitude to all those who supported me in conducting this study: to Professors Junichiro Itani, Kobe Gakuin University (emeritus Professor of Kyoto University) and

Takayoshi Kano, Primate Research Institute, Kyoto University for their critical readings of the manuscript, their valuable suggestions, and their continuous support; to Mrs. Maxine Randall, University of the Ryukyus and Mrs. Maureen MacKenzie-Taylor of the Communication Research Institute, Australia, for checking my English paper and giving me valuable comments; to Dr. Hiroyuki Takasaki, Okayama University of Science, for his help in the laborious \TeX typesetting of this manuscript; to Mrs. Sanae Nitta, University of the Ryukyus for typewriting the manuscript and drawing the figures; and to Mr. Seiichiro Nakamura for drawing a sketch for this text.

I am also indebted to the hospitality of all the kind people in Zaïre who received me just as a friend in the villages of Bowa and Wamba. Without their warm-hearted help and friendship this study would not have been possible.

REFERENCES

- Asato, L., T. Kano, S. Kuroda, S. Uehara, J. Takeda, G. Itani & M. Mbangi (unpublished). Flora list in Zaïre.
- Furuichi, T. (unpublished). New findings on witches and sorcery as directly observed among the Ngandu people, Zaïre. Paper presented at a seminar meeting for ecological anthropology held in Arima, Kobe in 1988. (in Japanese).
- Harako, R. 1977. Ecological-anthropological study on the Mbuti Pygmy. In (J. Itani & R. Harako, eds.) *The Natural History of Man*, pp. 29–95, Yūzankaku, Tokyo (in Japanese).
- 1981. The cultural ecology of hunting behavior among Mbuti Pygmies in the Ituri Forest, Zaïre. In (R.S.O. Harding & G. Teleki, eds.) *Omnivorous Primates: Gathering and Hunting in Human Evolution*, pp. 499–555, Columbia University Press, New York.
- Herskovits, M. J. 1926. The cattle-complex in East Africa. *American Anthropologist*, N.S., Vol. 28, pp. 633–664.
- Ichikawa, M. 1976. Hunting life of the Bambuti Pygmies. *Shizen*, 4: 26–40 (in Japanese).
- 1977. On “kuweri” and “ekoni”: Food taboo observed by the Bambuti Pygmies. In (J. Itani & R. Harako, eds.) *The Natural History of Man*, pp. 135–166, Yūzankaku, Tokyo (in Japanese).
- 1987. Food restrictions of the Mbuti Pygmies, Eastern Zaïre. *African Study Monographs*, 6: 97–121.
- Idani, G., S. Kuroda, T. Kano & L. Asato. 1994. Flora and vegetation of Wamba forest, central Zaïre with reference to bonobo (*Pan paniscus*) foods. *Tropics*, 3: 309–332.
- Irvine, F. R. 1961. *Woody Plants of Ghana with Special Reference to Their Uses*. Oxford University Press, London.
- Itani, J. 1977a. *Chimpanzee's Field: In Search for the Logic of Wild Life*. Heibonsha, Tokyo (in Japanese).
- 1977b. Ethnozoology of the Tongwe. In (J. Itani & R. Harako, eds.) *The Natural History of Man*, pp. 441–537, Yūzankaku, Tokyo (in Japanese).
- 1984. *Africa Voyage: Beyond the “Miombo” Forest*. Kōdansha, Tokyo (in Japanese).
- Takeya, M. 1974. The maintenance structure of the livelihood of the Tongwe. *Kikan Jinrui-gaku*, 5(3): 3–90 (in Japanese).
- 1976. Subsistence ecology of the Tongwe, Tanzania. *Kyoto University African Studies*, 10: 143–212.
- Kano, T. 1987. *Eliya no Hi (Pygmy Chimpanzee's Fire: Mysterious Tales of African Forest)*. Dōbutusha, Tokyo (in Japanese).
- 1996. *One Man's Tales of the Forest*. University of Tokyo Press, Tokyo (in Japanese).
- Kimura, D. 1991. Daily activities and social association of the *Bongando* in central Zaïre. *African Study Monographs*, 13: 1–33.
- Kuroda, S., T. Kano & K. Muhindo, 1985. Further information on the new monkey species, *Cercocebus salongo* THYS VAN DEN AUDENARE, 1977. *Primates*, 26: 325–333.

- Longan, K. A. & L. Jenik, 1974. *Tropical Forest and its Environment*. Longman, London.
- MacKenzie, M. A. 1991. *Androgynous Objects: String Bags and Gender in Central New Guinea*. Hardwood Academic Press, New York.
- Maes, J. 1924. Notes sur les populations des bassins du Kasai. *Mus. Congo Belge*, 1: 74–82.
- 1934. Notes sur les populations Lalia et Yasayama du territoire des Dzalia-Boyela. *Congo*, 15 (Part 1): 172–179.
- Murdock, G. P. 1959. *Africa: Its People and Their Culture History*. McGraw-Hill, New York, Tronto, London.
- Nishida, T. 1973. *The Children of Mountain Spirits*. Chikumashobou, Tokyo (in Japanese).
- Richards, A. I. 1969. *Land, Labour and Diet in Northern Rhodesia*. Oxford University Press, London.
- Sato, H. 1983. Hunting of the Boyela, slash-and-burn agriculturalists in the central Zaïre forest. *African Study Monographs*, 4: 1–54.
- Takeda, J. 1976. An ecological study of the honey-collecting activities of the Tongwe, western Tanzania, East Africa. *Kyoto University African Studies*, 10: 213–247.
- 1984. Hunting, hunting rituals and the distribution of meat of the Ngandu forest people. In (J. Itani & T. Yoneyama, eds.) *The Study of African Culture*, pp. 227–280, Akademia, Kyoto (in Japanese).
- 1987. Food ecology of the Ngandu forest people: Their subsistence and food intake-pattern. In (S. Wada, ed.) *Africa: Its Ethnological Study*, pp. 1071–1137, Dôhsha, Kyoto (in Japanese).
- 1990. The dietary repertory of the Ngandu people of the tropical rain forest: An ecological and anthropological study of the subsistence activities and food procurement technology of a slash-and-burn agriculturist in the Zaïre River Basin. *African Study Monographs*, Supplementary Issue, 11: 1–79.
- 1991. Life of the Ngandu as viewed from their rituals observed in birth, marriage and death. In (J. Tanaka & M. Kakeya, eds.) *Natural History of Mankind*, pp. 323–337, Heibonsha, Tokyo (in Japanese).
- 1992. People and life in Africa with special reference to their food procuremnt strategies. *Liberal Arts*, 6: 3–20 (in Japanese).
- Takeda, J. & H. Sato, 1993. Multiple subsistence strategies and protein resources of horticulturalists in the Zaïre Basin: The Ngandu and the Boyela. In (C. M. Hladik, A. Hladik, O.F. Linares, H. Pagezy, A. Semple & M. Hadley, eds.) *Tropical Forests, People and Food: Biocultural Interactions and Applications to Development*, pp. 497–504, UNESCO and The Parthenon Publishing Group, Paris.
- 1996. Stratégies de subsistance et apports en protéines du régime alimentaire des cultivateurs Ngandu et Boyela dela cuvette centrale du Zaïre. In (C. M. Hladik, A. Hladik, H. Pagezy, O.F. Linares, G. J. A. Koppert & A. Froment, eds.) *L'Alimentation en forêt tropicale: Interactions bioculturelles et perspectives de developpement*, pp. 771–780, Editions UNESCO, Paris.
- Tanno, T. 1977. Hunting and the composition among the Mbuti net-hunters. In (J. Itani & R. Harako, eds.) *The Natural History of Man*, pp. 97–134, Yûzankaku, Tokyo (in Japanese).

——— Accepted February 24, 1996

Author's Name and Address: Jun TAKEDA, *Department of Resource Management and Social Sciences, Faculty of Agriculture, Saga University, Saga, 840 Japan.*

Appendix 1. Wild animals hunted by the Ngandu.

Animals listed in this table are principally hunted for food and medicine. Some are not eaten because of food restrictions while others are not hunted because of traditional restrictions (Takeda, 1990). As the tropical rain forest is ecologically species-diverse, there are many unidentified or unknown species in the forest. For example, a new species of monkey (*Cercopithecus salongo*) has been recently discovered through Japanese research on the ecology of the pygmy chimpanzees (bonobo: *Pan paniscus*) in Zaïre (Kuroda et al., 1983).

Family name	Scientific name	Common name	Local name(1)
MAMMALS (<i>nyaama</i>)			
Macroscelididae			
	<i>Petrodromus tetradactylus</i>	Four-toed elephant-shrew	<i>litoko</i>
Mustelidae			
	<i>Mellivora capensis</i>	Ratel	<i>lopoko</i>
Potamogalidae			
	<i>Potamogale velox</i>	Otter shrew	<i>iyonge</i>
Pteropidae			
	<i>Eidolon helvum</i>	African fruit bat	<i>lolema</i>
Sciuridae			
	<i>Heliosciurus rufobrachium</i>	Red-legged sun squirrel	<i>bokoma</i>
	<i>Pumisciurus pyrrhopus</i>	Red-footed squirrel	<i>epehe</i>
	<i>F. lemniscatus</i>	Four-striped squirrel	<i>embonje</i>
	<i>Idiurus zenkeri</i>	Pygmy flying squirrel	<i>indumba</i>
	?	Flying squirrel	<i>bukio</i>
	<i>Aethosciurus poenis</i>	Green squirrel	<i>ekochi</i>
	<i>Protoxerus stangeri</i>	Giant forest squirrel	<i>lifo</i>
Cricetidae			
	<i>Cricetomys emini</i>	Giant rat	<i>botomba</i>
Thryonomyidae			
	<i>Thryonomys</i> sp.	Cane rat	<i>ichichi</i>
Hystricidae			
	<i>Atherurus africanus</i>	Brush-tailed porcupine	<i>iiko</i>
Manidae			
	<i>Manis tricupsis</i>	Tree pangolin	<i>ngaa</i>
	<i>Manis gigantea</i>	Giant pangolin	<i>ikanga</i>
Viverridae			
	<i>Nandinia binotata</i>	Two-spotted palm civet	<i>mbio</i>
	<i>Genetta sevalina</i>	Small-spotted genet	<i>simba</i>
	<i>G. tigrina</i>	Large-spotted genet	<i>simba</i>
	<i>G. victoriae</i>	Giant genet	<i>simba</i> or <i>bokondo</i>
	<i>Herpestes sanguineus</i>	Slender mongoose	<i>bongeemu</i>
	<i>Atilax paludinus</i>	Marsh mongoose	<i>bunju</i>
	<i>Crossarchus obscurus</i>	Dark mongoose	<i>ekanda</i>
	<i>Viverra civetta</i>	African civet	<i>yoo</i>
	<i>Viverra</i> sp.	African civet	<i>imongone</i>
	<i>Poiana richardsoni</i>	African linsang	<i>iyeni</i> (plural; <i>teeni</i>)

(1): Local names are shown in the singular forms of the Ngandu. The irregular plural form is shown in parentheses, while the words in brackets show the terms in the language of the neighboring Mongo.

Family name	Common name	Local name
Scientific name		
Hippopotamidae		
<i>Hippopotamus amphibius</i>	Hippopotamus	<i>nguo</i>
Suidae		
<i>Potamochoerus porcus porcus</i>	Western bushpig	<i>nsombo</i>
<i>Hylochoerus meinertzhageni</i>	Giant forest hog	<i>nsomboyaikanga</i>
Orycteropodidae		
<i>Orycteropus afer</i>	Aardvark	<i>lilukuma</i> or <i>iluo</i>
Bovinae		
<i>Syncerus caffer</i>	Dwarf forest buffalo	<i>mbolo</i>
<i>Boocercus euryceros</i>	Bongo	<i>nkenge</i>
<i>Tragelaphus spekei</i>	Sitatunga	<i>mbuli</i> (2)
Cephalophinae		
<i>Cephalophus monticola</i>	Blue duiker	<i>boloko</i>
<i>C. callipygus</i>	Peter's duiker	<i>mbengela</i>
<i>C. nigrifrons</i>	Black-fronted duiker	<i>mpambi</i>
<i>C. dorsalis</i>	Bay duiker	<i>kuluha</i>
<i>C. sylvicultor</i>	Yellow-backed duiker	<i>mbende</i>
Tragulidae		
<i>Hyemoschus aquaticus</i>	Water chevortain	<i>lukulukya</i> [etambi]
Galagidae		
<i>Galago demidovi</i>	Dwarf galago	<i>lisile</i>
Lorisidae		
<i>Perodicticus potto</i>	Bosman's potto	<i>kachu</i>
Cercopithecidae		
<i>Cercopithecus mona</i>	Mona monkey	<i>mbeka</i>
<i>C. neglectus</i>	Brazza's monkey	<i>mpunga</i>
<i>C. ascanius</i>	Red-tailed monkey	<i>nsoli</i>
<i>C. salongo</i>	Salongo monkey	<i>ekele</i>
<i>C. ?hamlyni</i> (3)	?Hamlyn's monkey	<i>ikese</i>
<i>C. ?dryas</i> (3)	?Dryas guenon	<i>tolu</i>
<i>Allenopithecus nigroviridis</i>	Allen's monkey	<i>elenga</i>
<i>Cercocebus aterrimus</i>	Black managabey	<i>ngila</i>
Colobidae		
<i>Colobus angolensis</i>	Black-and-white colobus	<i>luka</i>
<i>C. badius</i>	Red colobus	<i>yemba</i>
Pongidae		
<i>Pan. paniscus</i>	Pygmy chimpanzee (Bonobo)	<i>eelia</i>
Procaviidae		
<i>Dendrohyrax arboreus</i>	Tree dassie	<i>eeleku</i> [bombo]]
Elephantidae		
<i>Loxodonta africana</i>	African elephant	<i>njou</i>
<i>L. ?pumilio</i> (3)	?Pygmy elephant	<i>ikoloaki</i>
Felidae		
<i>Felis aurata</i>	Golden cat	<i>lowa</i> [londo]
<i>Panthera pardus</i>	Leopard	<i>nkoi</i>
? ?	?	<i>bolende</i>

(2): The female sitatunga with black skin is called *mbuli-lolika*.

(3): The identification is accurate at least to the genus level.

Family name	Scientific name	Common name	Local name
BIRDS (<i>pulu</i>)			
Alcedinidae	<i>Megaceryle maxima</i>	Giant fisher	<i>bondongidongi</i>
Bucerotidae	<i>Tropicranus albocristatus</i>	White-crested hornbill	<i>lochumba</i>
	<i>Ceratogymna atrata</i>	Black-casqued hornbill	<i>mpwa</i> ⁽⁴⁾
	<i>Bycanistes albotibialis</i>	Brown-cheeked hornbill	<i>yaata</i>
	<i>Tocus fasciatus</i>	Black-and-white-tailed hornbill	<i>bokonga</i>
Accipitridae	<i>Stephanoaetus coronatus</i>	African crowned eagle	<i>purungoli</i>
	<i>Pernis apivorus</i>	Honey buzzard	<i>ikolikoli</i>
	<i>Cuncuma vocifer</i>	African fish eagle	<i>eikei</i>
	<i>Accipiter toussenelii</i>	West African goshawk	<i>kombe</i>
Phasianidae	<i>Guttera edouardi</i>	Crested Guineafowl	<i>lokanga</i>
	<i>Afropavo congensis</i>	Congo peafowl	<i>litundu</i> ⁽⁵⁾
	<i>Afrancolinus squamatus</i>	Scaly francolin	<i>lohehelet</i>
	?	Quail	<i>bongongo</i>
	?	Quail	<i>isenjuli</i>
Picidae	?	Woodpecker	<i>lyondooko</i>
	?	Woodpecker	<i>lingwele</i>
	?	Woodpecker	<i>yolo</i>
Rallidae	<i>Himantornis haematopus</i>	Nkulengu rail	<i>bonjemba</i>
Strigidae	<i>Glaucidium perlatum</i>	Pearl-spotted owlet	<i>eteketeke</i>
Anatidae	<i>Pteronetta hartlaubii</i>	Hartlaub's duck	<i>bowa</i>
Psittacidae	<i>Psittacula krameri</i>	Senegal long-tailed parrot	<i>ekongo</i>
Musophagidae	<i>Corythaeola cristata</i>	Blue plantain-eater	<i>lokulakoko</i>
	<i>Tauraco persa</i>	Green turaco	<i>loka</i>
Columbidae	<i>Turtur afer</i>	Red-billed wood-dove	<i>echuha</i>
	?	Dove	<i>bokoko</i>
	?	Dove	<i>bototone</i>
	?	?	<i>bofofoa</i>
	?	?	<i>ihukihuki</i>

(4): The small-sized bird of this species is called *bolongo*, while the large-sized one is *bongonde*.

(5): The female of this bird is called *boksukulu*, while the male is *mbeka*.

Family name	Common name	Local name
Scientific name		
REPTILES		
Elapidae		
<i>Naja melanoleuca</i>	Black cobra	<i>biilimi</i>
<i>N. nigricollis</i>	Black-necked cobra	<i>bongeema</i>
<i>Dendroaspis jamesoni</i>	Green Congo mamba	<i>lokonga</i>
<i>Elapsoidea sundevallii</i>	De Coster's garter snake	<i>ibohui</i>
<i>Dendroaspis jamesoni</i>	Green Congo mamba	<i>lokonga</i>
Viperidae		
<i>Bitis gabonica</i>	Gaboon viper	<i>lichulambwa [liate]</i>
<i>Bitis nasicornis</i>	Rhinoceros viper	<i>mpele [ichuha]</i>
Boidae		
<i>Python sebae</i>	Common African python	<i>nkuma</i>
Colubridae		
<i>Natrix anoscopus</i>	Brown water snake	<i>liyoi</i>
Squamata ⁽⁶⁾	Snake	<i>lilembe</i>
Testudinidae		
<i>Kinixys erosa</i>	Hinge-backed tortoise	<i>eulu</i>
Chelonia ⁽⁶⁾	Tortoise (water-living)	<i>eyale</i>
Crocodylidae		
<i>Osteolaemus tetraspis</i>	Dwarf crocodile	<i>lokokwele [lokesa]</i>
<i>Crocodilus niloticus</i>	Nile crocodile	<i>nkoli</i>
Varanidae		
<i>Varanus niloticus</i>	Nile monitor	<i>lombe</i> (plural; <i>iyombe</i>)

(6): These names are the order names, not the family names.

Appendix 2. Glossary for the anatomical local terms and related terms used among the Ngandu for fauna.

Some of the names the Ngandu give the various cuts of meat pertain only to a particular ligament or bone, but usually these names refer also to the bones, meat and skin sections cut from the animal as a whole. Accordingly, their system of classification, as observed in the butchering of hunted animals and dead animal bodies or in the terms they use in daily life, is different from that based on our anatomical classification. However, it is fundamental to know the folk taxonomy for their faunal environment and the extent to which they are familiar with the animal world.

The names are given in the singular form in the Ngandu language, which has some aspects in common with the neighboring Mongo language. The Mongo words are given in brackets [] where there is an equivalent term to the Ngandu. At the same time, both singular and plural forms are given where there are irregular changes between them.

bainye (plural; = [*masapo*]): urine.

cf. *toi* (plural; =): droppings or dung.

bamba (plural; =): an oblique tooth or a double tooth.

basebalielle: milk or mother's milk: *base* (water) + *liele* (breast). When an infant animal is killed it may have something like curdled milk in the stomach. The Ngandu are very fond of this portion and call it *matala-nyaama*, which means "steamed cassava like meat."

cf. *liyele* (plural; *baye*le): women's breast.

bauli: cf. *luuli*: birds' feathers.

beembo (plural; =): elephants' trunk.

cf. *ikasa*: the end of the elephant's trunk; eating this portion is prohibited, because it acts like human hands. An *nkangongala* (elephant magician hunter) cuts off this portion first and digs a hole in the ground nearby to bury it before the carcass is dismembered. This burial is called *kunja*.

cf. *kunja*.

cf. *boolu*: nose or snout.

cf. *likasa*: hand.

besoho: cf. *bosoho*: intestines.

beuwa-ba-laanga (plural; =): bone of the lower jaw.

cf. *beuwa* (plural; *buuwa*): bone.

cf. *biyo* (plural; *tou*): finger or toe.

cf. *iyolachindo*: little finger or toe; *chindo* meaning the end.

cf. *iyolatoto*: fingers or toes except the little fingers.

cf. *iyolomi*: thumb or big toe.

bohehehohe (plural; *behehehohe*): nerve.

cf. *lihohe*: spider's web.

bohoho (plural; *behoho*): trachea; also called *bohoho-ya-kongoli*, because of a similarity in shape to a species of centipede *kongoli*. The *bohoho* portion of a Guinea fowl is usu-

ally discarded in the kill.

cf. *bohoho-ikologongo*: the portion where the bronchus branches off or attaches to the lungs.

bohoho-ba-toma or *bohoho-a-toi*: esophagus.

cf. *toma*: things.

cf. *toi*: droppings or dung.

bohongo: bushpig's tail.

bohuhu: tails of terrestrial *eulu* or water dwelling *eyale* turtles.

bohumba: the portion, approximately equivalent to the bones and flesh including the skin of the back, which contains the breastbone with the attached ribs and the meat adhering to it; so this usually includes the two thoracic vertebrae (*likuleelo*) connected to the cervical vertebrae and the front thoracic vertebrae of the lumbar vertebrae.

cf. *buusa*.

cf. *likuleelo*.

bokalaku: half of the body when the body is cross-sectionally cut off along the midline.

bokali: tails of crocodiles or *nyaama-kolomo* such as mongooses, dogs or monkeys, but it does not include the *chungu* portion buttocks.

cf. *eeese*: tails of elephants, bushpigs or *nyaamalokolo*.

cf. *iyongo* or *losolongo*: tails of snakes (*njua*).

bokalu: thick black hairs on the end of an elephant tail *eeese*; when used, the hairs are usually woven into a wrist band called *lusimbo* which is worn on the left wrist. However, they are not worn so often. The Tongwe, who live on the eastern side of Lake Tanganyika (Nishida, 1973; Kakeya, 1974; Itani, 1977b; Takeda; 1984, 1992) weave these hairs very elaborately for wrist-

- bands while those worn by the Ngandu are very simple with only one knot.
- bokeke*: one portion of the belly, which is between the *lingongo* and *lisenga* portion.
- bokila*: blood. *Bokila mabe* means unfortunate ([*mabe*] meaning bad in Lingala).
- bokoke*: spines of animals like the brush-tailed porcupine (*iiko*) or short, stout spines.
cf. *iuka*.
cf. *jenje*.
- bokoli-ya-chungu*: anus.
cf. *bokoli*: mouth or opening.
cf. *likuchu*.
- bokolo*: lower part of the fore limbs or hind legs.
cf. *likaka*.
cf. *lichinji*.
cf. *lokolo*.
cf. *loo* (plural; *beo*).
- bokolo*: claws of crabs like *likachu* crab. The crabs are not so common in rivers.
- bokolokolo*: skull excluding the jaw bone.
cf. *boote*: head.
cf. *ehokoso*.
- bokondo*: a skin or pelt of the bongo (*nkenge*), sitatunga (*mbuli*) or Congo clawless otter (*liyololo*: plural; *baololo*)* which is cut off in a width of several-centimeters from the head to the joint of the tail along the midline, and is used for a special use in a *likita* ceremony for *taata-na-mwana*. The *bokongo* is used as a waist band *bokoli* [*kamba*] in the ceremony.
cf. *ekoto*: waist band.
cf. *bokondo*: waist band.
- bokongo*: shoulder.
cf. *bokongo-bokungu*: female genital organs.
cf. *bokongoloko*: backbone.
- bokongo* or *bokungu*: female genital organs
cf. *boleka*.
- bokongoloko*: backbone.
cf. *liyoko* or *liyoko-lokongo* (plural; *baokobokongo*): one vertebra.
cf. *yongo* (plural; *baongo*): intervertebra.
- bokungu*
cf. *bokongo*.
- boleka*: female genital organs; unmentionable words¹ in the presence of women.
cf. *bokongo*.
cf. *lambo*.
cf. *lokunjua*: testicle.
cf. *nsoka*: penis.
- bolembe*: the portion contains the hipbone, from which the meat of the buttocks (*chungu*) has been removed, and the meat adhering thereto.
- bolenge*: horn of a snake like single-horned adder (*mpele*).
cf. *bangua*: a snake fang.
cf. *binu* (plural; *bainu*): tooth in general.
cf. *bopati*: elephant tusk.
cf. *liseke*: antelope horn.
- boliyo*: animal hair.[‡]
cf. *bosha*.
- boloko* [*motema*]: heart; usually used as *lisololooko* (lungs and heart), because this portion is removed together in the butchering. Also means the spiritual heart although *botema* is usually used, the core of the heart and the pith of a plant; while kidneys (*ilondoola*) are, for short, called *boloko* as well.
cf. *botema*: center of a matter or thing.
cf. *ilondoola* (plural; *tolondoola*): kidney.
- bolombo* or *buuha-la-lihimo*: portion around the pit of the stomach; the lateral belly and lower belly; along the lower edge of the lower rib.
cf. *buuha*: the portion which consists of the bones and meat including the skin of the breast including part of the ribs and cervical vertebrae.
cf. *lihimo*: the portion which contains the skin and meat of the belly including (if the animal is a male) the scrotum (*lokunjua*) and penis (*nsoka*).
cf. *jemmi* [*lihimo*]: belly, which may also mean pregnancy.
- bolonge*: incisor tooth of the upper and the lower jaws.
cf. *ekeku*: teeth other than the incisors.
- bolongo*: longest feather of the tail of a bird.

* A kind of *nyaama-kolomo*, which lives in the water, but differs from an *iyonge* otter; the blackish skin (*ekoto* or *bokongo*) is also used in the *likita* ceremony.

¹ These terms are called *bitoi* (singular; *etoi*). Instead of this unmentionable word, *bokongo*, *lambo* or *lokunjua* are spoken in daily life.

[‡] When a child or infant suffers from the *beeko* disease, induced by eating the meat of a black-and-white colobus (*luka*) (Takeda, 1990, 1991), the parent prescribes a medicine (*boote*) made by mixing the shavings of three different trees with the burnt hairs (*boliyo*) of a black-and-white colobus. The liquid from this mixture is warmed in a leaf wrapping (*liboke*) and then inserted into the anus of the child as an enema (*lichule*) (Takeda, 1991).

- bomwe* (plural; *beimwe*): barbel of fish such as cat fish or electric cat fish (*nchula*), and the whiskers of some *nyaama-kolomo* prey such as the brush-tailed porcupine.
cf. *bokoke*.
cf. *iuka*.
- bongolo*: stripes on the skin of the flank of some antelopes such as sitatunga (*mbuli*), bongo (*nkenge*) or *ilangambuli* (a species of sitatunga).
cf. *liyanda* (plural; *baanda*): spots on an animal hide.
- bongongo*: bill or beak of birds.
- bonyuwa-liosko* (plural; *benyuwa-soko*): the portion is equivalent to the *chungu* meat of the buttocks excluding the hipbone.
- boolu*: nose or snout.
cf. *engongo*: snivel.
cf. *iyoko*: tip end of the nose or snout.
cf. *beembo*: elephant's trunk.
- boona*: uterus or child.
- boongo*: brains.
cf. *pongo*: marrow.
- boote* [*butu*]: head which is composed of both the *ehokoso* portion and the *laanga* portion; *ehokoso*; head without skull (*bokolokolo-boote*).
- boseko*: the top layer of muscles along the side of the neck running from the nape to the shoulder, including the skin. When dissecting *nyaama-kolomo*, this section of the animal is first cut into left and right halves for removal. In the past, only men ate this portion because of the *bitamu* taste (i.e., laced with fat and therefore delicious), but today women and children eat it, too.
- bosenge*: the portion which contains the skin and meat of the side of the chest (the flank; i.e., both sides of the *lihimo* portion).
- bosha* or *boshe* (plural, *beisha* or *beshe*): hair or pubic hair of mammals.
cf. *beshekolu*: hair of hands or legs.
cf. *besheolu*: hairs inside the nostrils.
cf. *boliyo*: hairs of animal skin.
cf. *liho*: hairs of the head.
cf. *likele*: sidelocks.
cf. *lipinga*: hairs on the belly.
cf. *lokiki*: eyebrows.
cf. *lokongi*: eyelashes.
cf. *lolelu* (plural; *detu*): mustache, beard or the comb of a cock.
cf. *lwali* (plural; *bawli*): bird's feather.
cf. *shalokangu*: hairs of the armpit.
- bosisa* (plural; *besisa*): a blood vessel.
- bosoho* (plural; *besoho*): the colon, small intestine and rectum (*buneo*) are collectively called *besoho* with no special name for the intestinal membrane, and is ordinarily used in the plural form. This portion is called *bitamu* (fatty and delicious), and so is liked best by the Ngandu.
- bosombu*: crocodile's snout.
- botema* [*motema*]: center of a matter or thing, or pith of a plant.
cf. *boloko*: heart.
cf. *botema-a-likasa*: palm.
- bouwa*: cf. *buuwa*: bone.
- buuha*: the portion which contains the bones, meat and skin of the breast including part of the ribs and cervical vertebrae.
cf. *bolombo*
- buuha-la-lihimo*: cf. *bolombo*.
- buneo*: rectum.
- buusa*: lumbar vertebrae and the meat adhering thereto (i.e., the meat and bones of the lower back); under the *iseke* portion and above the *bolembe* portion.
- buuwa* (plural; *beuwa*): bone.
cf. *buuwa-belama*: thighbone.
cf. *buuwa-bokolo*: lower leg bone.
cf. *beuwa-byalikaka* (plural): foot and toe bones.
- chungu*: the meat of the buttocks excluding the hipbone (*bolembe*).
cf. *chungu-solosolo*: the buttocks of the animal minus the *linene*.
cf. *linene*.
- eele* (plural; *biyele*): breast of animals in general.
cf. *liyele* (plural; *bayele*): woman's breast.
- eese*: tails of elephants, bushpigs or *nyaama-lokolo* such as antelopes; the tail belongs to the *chungu* portion buttocks.
cf. *bokali*: tails of crocodiles or *nyaama-kolomo*.
- ehagasu* or *ehangaswa* (plural; *biyangaswa*): gills of a fish.
cf. *liyangayanga*.
cf. *ntonga*: pectoral fin.
- eilu* (plural; *biila*) [*elongi*]: face.
- einyele*: bladder.
- ekakela-na-besoho*: pancreas.
cf. *lichina-losoho*.
- ekeku*: any tooth except the incisor (*bolonge*).
- ekila*: the vital part the hunted animal which is the target of a hunter; meaning the food

taboo or social regulation in ordinary usage (Takeda, 1987, 1990, 1991). The *ekila* portions are considered among the Ngandu as follows:

- [1] *buusa-kingu*: joint of the occipital region.
- [2] *shalokangu*: near the armpit rather than the heart.
- [3] *lihimo*: belly, but the outer part outside the liver.
- [4] *pengele*: interior part of the upper forelimbs. Incidentally the same part of the hind legs is not culturally significant.
- [5] *bochichi-anbuusa*: upper part on the buttocks near the backbone.
- [6] *nse-laanga*: joint part of the jaws.
- [7] *likwalokiki*: protuberance part above the eyes.
- [8] *ihangahanga*: the pit of the stomach.

ekolokolo: coccyx.

ekombo: crown feathers on the top of a hen's head.

cf. *imbombo*: hairs which become erect on the crest of an animal such as black mangabey (*ngila*).

ekoto (plural; *bikoto*): flayed skin, cut in a width of several centimeters along the midline from the head to the joint part of the tail, called *bokondo* and used as a waist band in some ceremonies. The skin of golden cats (*lowa*), which have spots (*lirono*) on the belly, are also used as *ekoto*; *simba* and *bolende* genets' *ekoto* is a *lisondo* bridewealth which is given from the bride's family to the bridegroom's side (Takeda, 1991).

cf. *bokondo*.

elama: thigh portion.

cf. *buuwa-belama*: thighbone.

elungi: forehead or temple part in the face.

ikasa: the end of the elephant's trunk (*beembo*).

cf. *beembo*.

cf. *likasa*: hand.

ikengo (plural; *tokengo*): collarbone.

ilangambuli: a *sitatunga* (*mbuli*) which has stripes on the flanks with the same body color as the Peter's duiker (*mbengela*).

ilondoola (plural; *tolondoola*): the kidney (*boloko-bokongo*) and the meat adhering

thereto (*bochichi-anbuusa*: inside the muscles along the backbone and above the iliacus muscle).

imbombo: ruminoreticulum.

isambu: a part of the *linene* muscles adhering to the buttocks *chungu* opposite the tail side; the underneath part when the *chungu* portion is hanging down.

cf. *chungu-solosolo*: buttocks minus the *linene* portion.

cf. *linene*: front part adhering to the buttocks.

iseke: the last of the thoracic vertebrae connected to the lumbar vertebrae, and the meat adhering thereto; muscles and spine between the *bohumba* portion upper side and the *buusa* portion lower side.

isolì (plural; *baisolì*): tear.

iuka: thin, long spines of a brush-tailed porcupine (*iiko*).

cf. *bokoke*.

cf. *jenje*.

iyango: a site dug by animals in the forest in search of something underground such as a salt lick; bay duikers (*ku-luha*), Peter's duikers (*mbengela*), blue duikers (*boloko*) or pygmy chimpanzees (bonobo; *eelia*: *Pan paniscus*) also search for things such as a kind of yam (*ehusu*: *Dioscorea minutiflora*), *lokaso* (fruits of *bokaso* trees: *Tetracarpidium conophorum*, Euphorbiaceae), and such under the ground.

iyehu (plural; *baehu*): navel.

cf. *bongolu*: protruding navel.

cf. *kohi*: umbilical cord (for detailed medical treatment in a childbirth, see Takeda, 1991).

iyele (plural; *tele*): the gland on the face of antelopes.

cf. *liyele*: milk.

iyembu (plural; *baemu*): fetus, any kind of animal is eaten by the Ngandu whether or not it has hairs on the body (Takeda, 1990).

iyoka (plural; *took*): bushpig's breast or nipples.

iyoko: end of rabbits' nose.

cf. *chimbi* (plural; *limbi*): rabbit's tail.

iyonge [*nzoto monene*]: large-sized body or round body.

iyongo: waist or portion around the waist of the shoulder side.

iyongo: tail of a snake (*njua*).

cf. *bokali*.

cf. *losolongo*.

jemmi [*libumu*]: belly or abdomen; sometimes meaning pregnancy in ordinary usage.

cf. *bolombo*.

cf. *lihimo*: skin and meat of the belly.

jenje: *iiko* or brush-tailed porcupine's tail; it rattles when the animal is moving, and so is sometimes a good means for a hunter to locate the prey in the forest.

cf. *boko*.

cf. *iese*.

cf. *iuka*.

cf. *lisanga*: the end of the *jenje* tail which has thick whitish hairs that make such a sound.

kalangu: muscles along either side of the backbone; the two sets of boughs set in the *elongo* elephant trap are also called *kalangu* (see the text and Fig. 9).

kingu: the *kingu* portion is usually equivalent to the neck, but in the case of snakes where the neck area is not always clearly demarcated, the *kingu* consists of the section between the head and the rest of the body; situated below the head *boote* and above the *likuleelo* portion; it is composed of the following three portions:

[1] *liyomo*: the *liyomo* portion which is the upper half of the neck (*kingu*) including the trachea (*bohoho*) and esophagus (*bohoho-ba-toma*).

[2] *gomo*: portion between *liyomo* and *buuha*.

[3] *buuha*: the *buuha* portion, which is equivalent to the skin and meat of the belly, including part of the ribs and cervical vertebrae, and so contains the bones and meat including the skin of the breast; containing *litombo* a part of *buuha* portion.

cf. *bohumba*.

cf. *kako-la-kingu*: throat-clearing.

cf. *likuleelo*.

kohi: umbilical cord (refer to Takeda, 1991, for traditional medical treatment of the Ngandu).

cf. *iyehu*: navel.

*kuta*³: circumcision (Takeda, 1991) or meaning to bend the hoofs of the hind legs and push them between the skin cut around the *lambo-la-lokolo* portion; after the *kuta* is done, butchering of the carcass begins. cf. *nsoka* (plural; =): penis.

lambo (plural; *bambo*): testicles or plants' fruits.

cf. *boleko*.

cf. *lambo-la-lokolo*: anterior muscles of the waist and hipbone or superior muscles anterior to the joint of the hind leg.

lambo-la-lokolo (plural; *bambo-lekolo*): the *lambo-la-lokolo* portion contains the top layer of muscles where the hind legs are joined to the torso at the belly including the skin corresponding to the *losyua* of the front leg; muscles situated anterior to the waist and hipbone or superior muscles anterior to the joint of the hind leg, which are situated near the quadriceps femoris muscle; only muscles of this portion are cut off in the butchering, while the *boseko* portion is removed with the skin.

cf. *lambo*.

cf. *losyua*: muscles around the joint of the foreleg.

leeleme: spleen.

leeo (plural; *jeeo*): shoulder blade or scapula.

cf. *lokole*: scapula of a hinge-backed tortoise (*euhu*; terrestrial) which is used as an amulet against evil (*likoko*) (Takeda, 1991).

lichina-losoho: pancreas; portion composed of the *lichina* (joint or estuary) and the *besoho* (intestines).

cf. *ekakela-na-besoho*.

lihimo: skin and meat of the belly, including the scrotum (*lokunjua*) and penis (*nsoka*) if the animal is a male, and also including the rib section.

cf. *bosenge*: portion on both sides of the *lihimo*.

cf. *jemmi* [*libumu*]: belly or abdomen.

liho: hair of the head.

cf. *bosha* or *boshe*: hair.

likaka: foot.

cf. *beuwa-bya-likaka* (plural): bones of foot and toes.

³The butchering of most *nyaama-lokolo* antelopes or dwarf forest buffalo (*mbolo*) begins after the *kuta*; however, blue duiker (*boloko*), which belongs in the category of small-sized antelopes, has no *kuta*. When the animal carcass must be carried within a man's shoulder bag (*tombi*), *kuta* is done, if possible, before rigor mortis sets in. This also makes it easy for a man to walk through the forest because of the smaller bulk. Moreover, when *kuta* has been done, the carcass is easier to put into the boiling vessel, for cooking meat which is to be dried.

- cf. *ikolu*: toe; the finger is called *iyó*.
 cf. *ikololomi*: big toe; composed of *ikolo* and *boomi* (mother).
- likasa*: hand.
 cf. *botema-a-likasa*: palm.
 cf. *buusa-a-likasa*: back of the hand.
 cf. *ikasa*: tip of the elephant trunk (*beembo*).
 cf. *ilome*: right hand or right side.
 cf. *iyali*: left hand or left side.
 cf. *iyó*: finger; the toe is called *ikolu*.
 cf. *iyó-la-chindo*: little finger.
- likele*: sidelocks.
- liko*: liver.
- likuchu*: anus; usually the little protruding anus of *nyaama-kolomo* (plural; *nyaama-la-kolomo*), although the ordinary non-protruding anus is called *bokoli-ya-chungu*; discarded in the forest at the time of the kill, but this portion of a brush-tailed porcupine (*iiko*) is eaten, although it is classified as *nyaama-kolomo* by the Ngandu because it does not protrude.
- likuleelo*: the bones and meat of the two thoracic vertebrae connected to the cervical vertebrae including the two pairs of ribs attached thereto; situated below the kingu, but above the *bohumba* portion i.e., below the neck and throat.
- likungu-leiko*: the skin along the spinal column above the waist which has a small amount of meat adhering to it, such as for a brush-tailed porcupine (*iiko*); composed of *likungu* and *iiko*.
 cf. *bokongo*: shoulder.
- likunju*: stomach; situated below the *imbombo* portion, but dealt with as one *likunju-imbombo* portion which includes the main stomach itself (*likunju*) together with the part of the stomach (*imbombo*) which connects to the esophagus (*bohoho-ba-toma*); the portion below the *likunju* belongs to the *bosoho* portion while the large intestine and colon are largely called *pungusoho*[¶] which is composed of the *pungu* and *bosoho*.
- liloka*: gall bladder. According to folk zoology, there is a *liloka* organ in such animals as the black-fronted duiker (*mpambi*), yellow-backed duiker (*mbende*), bay duiker (*kuhu*), blue duiker (*boloko*), Peter's duiker (*mbengela*), bongo (*nkenge*) or bushpig (*nsombo*), *nyaama-kolomo* or *eulu* land tortoise, while the organ is lacking in animals such as a water chevrotain (*lukulukya*), sitatunga (*mbuli*) or elephants (*njou*). The organ is generally discarded in the forest; this may be connected with their belief that this organ is used by sorcerers (*boloki* [*ndoki*]) to induce illness and sometimes death (Takeda, 1991).
- limate*: hoof of ungulates; not eaten by the people, but a hollow *limate* is used as an amulet against evil (*likoko*); the inner part of the hoof is burned after the hoof is left for three days or so, the inner part is pulled out with a *bokombe* vine (*Haumania liebrechtsiana*, Marantaceae) set between the slit of a cloven hoof.
- limbombo*: erect hairs on the crest of a black mangabey (*ngila*).
 cf. *ekondo*.
- lindomba*: hairy tails of small rodents (*poo*).
- linene*: part of the muscles adhering to the *chungu* buttocks.
- lingongo*: head (*boote*) and front limbs (*loo*; singular) which contain the neck, both hands, breast, the *liyomo* portion (upper part of shoulder) and internal organs such as stomach or lungs; above the position of a waist band (*bokondo*), called *lokondo*, which is the boundary between *lingongo* and *lisenga*.
 cf. *lisenga*: portion below the navel, which contains both hind legs, etc.
- linu* (plural; *bainu*): tooth.
- liseke*: horn of an ungulate; horns of bongo, dwarf forest buffaloes (*mbolo*) or sometimes goats (*ntaba*) used for making sounds, although sitatunga's horns are preferred as materials for making *pongo* with low tone. These horns are used not only in the hunt (see Note (11)), but also in village life for coded messages such as in a talking drum (*lokule* [*ngoma*]). It is possible for the messages sounded by the *bopati* horn to reach a distance from several hundreds to one thousand meters. The talking drums in Nigeria, West Africa, however, are used as a means to send messages for a short distance.

[¶] Like the *lisolo-looloko* portion, which is not cut off in the kill and is dealt with as one portion.

^{¶¶} The Ngandu people say elephants have no *likunju*, but instead, have *pungusoho*; this idea may be connected with the fact that elephants have no ruminant stomach.

- cf. *bopati*: elephant's tusk.
 cf. *ilenge*.
 cf. *losia*.
- lisele*: female genital organs which are swollen in estrus, especially for pygmy chimpanzees (*eelia*).**
- lisenga*: *bolembe* portion (which contains the hipbone, from which the meat of the buttocks *chungu* has been removed, and the meat adhering thereto) and the hind legs; situated below the navel.
 cf. *bolembe*.
 cf. *chungu*.
 cf. *lingongo*.
- lishoko*: shoulder or wing of a bird.
 cf. *bonyuwa-lishoko*.
- lisolo*: lung, situated above the *lihimo* portion and above the *litombe* (diaphragm); *nkangohonda* (bushpig magician hunter) gets this portion as *eyali* in the *bohonda* hunting (see the text).
- litombe*: bat's wing or diaphragm.
litombo: a part of the breast portion *buuha*.
litono: spots on the skin of an animal.
 cf. *liyanda*.
 cf. *bongolo*: stripes on the skin of an animal.
- liyanda* (plural; *baanda*): spots on the skin of an animal.
liyanggo (plural; *baango*): knee.
liyele (plural; *bayeleye*): breasts or nipples of a female.
- liyoko*: a backbone.
lohanji (plural; *panji*): rib; a stick (*lohoho-la-lombo* or *lohoho-la-njou*) made of an elephant's rib, is used by women to harden the soil-floor of a termite hill.
- lohuku* (plural; *puku*): froth coming from the mouth.
lokola (plural; *kola*): nail; nails cut from a child are used as an amulet against evil (*likoko*) (Takeda, 1991).
- lokolo*: hind leg.
 cf. *chungu*.
 cf. *loo* (plural; *beo*): front limb.
- lokondo*: the boundary between the upper and lower halves of the body; approximately equivalent to the position where a waist band (*bokondo*) is fastened.
lokunjua (plural; *kunjua*): scrotum. See also the footnote for *lisele*.
- cf. *boleka*
lolehu (plural; *dehu*): mustache, beard or watle.
lolemu: tongue.
loo (plural; *beo*): front limb which is composed of *lichinaloo* (upper limb), *bokolo* (lower limb) and *limate* (hoof); this portion includes the three thoracic vertebrae outside the *buuha* portion.
 cf. *lokolo*: hind leg.
loo (plural; *beo*): leg.
losala (plural; *sala*): plume or tail feather.
 cf. *luuli* (plural; *bauli*): feather of a bird.
losia (plural; *sia*): short horn of male Peter's duiker (*mbengela*), blue duiker (*boloko*), bay duiker (*kuluha*), yellow-backed duiker (*mbende*) and black-fronted duiker (*mpambi*); horns made of *losia* are called *ilenge* (plural; *tolenge*) and have a high-pitched tone rather than *pongo* horns of *liseke* with low tone; usually carried by the *nkangotai* (magician hunter in the *baki-mano* collective net-hunting).
 cf. *liseke*.
losyua (plural; *jyosyua*): the portion which contains the layer of muscles underneath the front leg where it meets the torso; i.e. approximately equivalent to the armpit (*shalokangu*) in humans (also see the text).
 cf. *lambo-la-lokolo*: the hind leg portion equivalent to the *losyua*.
losolongo: snake's tail.
 cf. *bokali*
 cf. *iyongo*.
luuli (plural; *bauli*): bird feather.
 cf. *losala* (plural; *sala*): plume or tail feather.
njua (plural; =): snake.
nsoka (plural; =) [*isatu* or *losonge*]: penis.
 cf. *bokongo*
 cf. *boleka*
 cf. *etoi*
 cf. *kuta*: circumcision (Takeda, 1991).
pongo (plural; =): bone marrow; liked by the Ngandu and is termed tasty (*bolochi*); it is considered similar to the taste of brain (*boongo-na-nyaama*).
pungusoho: large intestine including the colon, but there is no special vernacular word for caecum; it is believed that the elephant has

** A swollen genital organ of a woman which has been caused by some disease like elephantiasis is also termed *lisele*, although a man's swollen scrotum (*lokunjua*) caused by the same disease, is called *lingunju* which is a quite different name.

this portion, but not the *likunju* portion.
cf. *bosoho* (plural; *besoho*): intestines.
putu (plural; =) [*ndeke*]: bird.
shalokangu (plural; =): armpit or hairs of the

armpit.
cf. *losyua* (plural; *iyosyua*).
toi (plural; =): droppings or dung.