

Title	Where Do Constructional Meanings Come From? --But They Will Come From Nowhere If They Are Mere "Form/Meaning Pairs"?--
Author(s)	KURODA, Kow
Citation	言語科学論集 = Papers in linguistic science (1997), 3: 17-44
Issue Date	1997-12
URL	<a href="http://dx.doi.org/10.14989/66939">http://dx.doi.org/10.14989/66939</a>
Right	
Type	Departmental Bulletin Paper
Textversion	publisher

## Where Do Constructional Meanings Come From? (But They Will Come From Nowhere If Constructions Are Mere "Form/Meaning Pairs")

Kow Kuroda  
Kyoto University  
e-mail: kuroda@hi.h.kyoto-u.ac.jp

### 1 Introduction

The aim of this paper is twofold: it is intended as a critical assessment of Goldberg's (1995) construction grammar account of argument structure phenomena, on the one hand,<sup>1</sup> and as a brief sketch of my alternative to it, with minimum introduction to the framework, which I call pattern matching analysis, that serves as, on the other.

My arguments go as follows. I start by pointing out that while Goldberg's construction grammar account is interesting as far as the following points are concerned: (i) the existence proof of constructional meanings (and constructions), (ii) her proposal of the characterization of constructions, and (iii) the elaboration of her hypothesis about how constructions are organized in grammar (of English). These are important groundworks, but there is a question that is not answered or even addressed. It is the question of emergence, or of "where constructional meanings come from". When we state, like Goldberg does, that form  $F = X V Y (P) Z$  has a constructional meaning  $M$ , which Goldberg claims can be approximated by  $M = X \text{ CAUSES } Y \text{ TO RECEIVE } Z \text{ BY } V\text{-ING } Z$ , for example, nothing interesting is specified unless it is already accounted for why  $M$  should have such specification, or, in other words, why  $F$  is unlikely to have "other" meanings like  $X V Z \text{ SO THAT } Y \text{ RECEIVE } Z$ , on the one hand, in addition to stating that  $F$  is more unlikely to have such strange meanings as  $X \text{ ASKS WHETHER } Y \text{ RECEIVES } Z \text{ OR NOT BY } V\text{-ING } Z$ , on the other. I will suggest that this is a serious gap in all accounts which make a crucial assumption that grammatical construction is "pairing of form and meaning", because the assumption precludes the question of emergence, or where such meanings like  $M$  above come from, even if it is possible to question how form/meaning pairs are "organized" in grammar.

On account of my question of emergence, I claim that argument structure constructions in the sense of Goldberg are exactly schematization of syntactic contexts into which some special, very frequently and productively used verbs like *give*, *put*, *get*, *make* fit best. The intuitive idea is very simple:  $F = X V Y Z$  (e.g., *Ann faxed Bill the memo*) is categorized as Goldberg's Ditransitive Construction, for example, only if  $F$  is a "blend" of two patterns (= form/meaning pairs),  $D = X V Z$  (e.g., *Ann faxed the memo*) and  $E = X W Y Z$  (e.g., *Ann sent Bill the memo*), assuming that the syntactic-semantic operation of "pattern blending" (my extension of Fauconnier's (1997) notion of "conceptual blending") is a pairwise unification of partial (mis)matches between  $D$  and  $E$ , on the one hand, and "override" of  $V$  over  $W$  is permitted. From this blending perspective, construction effect is characterized as syntactic/semantic override of  $D$  over  $E$ . This characterization, I want to claim, can improve and enrich Goldberg's account in terms of grammatical constructions on the following grounds: (i) it is of no use to represent so-called constructional meanings of  $E = X V Y (P) Z$  in abstract terms as  $X \text{ CAUSES } Y \text{ TO RECEIVE } Z \text{ BY (MEANS OF) } V\text{-ING } Z$ ; (ii) such constructional meanings are ambiguous because of the ambiguous meaning of the host pattern  $E = X W Y (P) Z$  (where only  $X$ ,  $Y$  and  $(P) Z$  are lexically present, but  $W$  is absent), provided that the ambiguity of the pattern stems exactly from the ambiguity of  $W$ , which is absent and can, at best, be approximated by a verb depending on the combination of  $X$ ,  $Y$ ,  $(P)$ , and  $Z$ .

This line of claims are admittedly controversial, or at least not so well established that they can go without justification (at least within the circle of cognitive linguistics). It is likely, I guess, that my alternative account will be accused for its treatment of semantics. Indeed, it accurate to say that my account more makes implicit (or transparent, in other words) than makes explicit the semantic contribution of pattern  $E$ . But this is itself one of my points. Even if constructional meaning of  $E$

1. For other aspects of construction grammar, see Fillmore, et al. (1988) and Kay (1997).

exist, which I hold with Goldberg, it is not guaranteed at all that it is possible to represent them. I claim that it is inappropriate to assume that forms and their meanings are separable. I rather claim that if sentences have meanings at all, then forms are themselves meanings, rather than they are (mere) expressions of them. For this purpose, I will sketch a theoretical framework, pattern matching analysis, that gives conceptual and technical foundations to my claims.

## 2 Review of Goldberg's Construction Grammar Account of Argument Structure

According to Goldberg (1995), three groups of sentences in (1), (2), and (3) illustrate what she calls Ditransitive Construction, Caused Motion Construction, and Resultative Construction, which in turn are special cases of Argument Structure Construction.

- (1) a. Joe kicked Bill the ball. (p. 54)  
 b. Pat faxed Bill the letter. (p. 3)  
 c. Chris baked Pat a cake. (p. 34)
- (2) a. Pat sneezed the napkin off the table. (p. 3)  
 b. They laughed the poor guy out of the door. (p. 152)  
 c. Sam helped him into the car. (p. 152)
- (3) a. Pat hammered the metal flat. (p. 81)  
 b. He ate himself sick. (p. 192)  
 c. She kissed him unconscious. (p. 3)

Goldberg's claim is that, under the general definition of constructions as "pairings of syntax and semantics that can impose particular interpretations on expressions containing verbs which do not themselves entail the given interpretations" (p. 220), the three cases of the argument structure construction, illustrated above, are such pairings of form  $F$  and meaning  $M$ , denoted by  $C = \langle F, M \rangle$ , as specified in (4), where all occurrences of  $BY V\text{-ING } (Z)$  are my extrapolation.<sup>2</sup>

- (4)  $C_1 = \langle F = X V Y Z; M_1 = X \text{ CAUSES } Y \text{ TO RECEIVE } Z \text{ BY } V\text{-ING } (Z) \rangle$   
 $C_2 = \langle F = X V Y Z; M_2 = X \text{ CAUSES } Y \text{ TO MOVE } Z \text{ BY } V\text{-ING } (Y) \rangle$   
 $C_3 = \langle F = X V Y Z; M_3 = X \text{ CAUSES } Y \text{ TO BECOME } Z \text{ BY } V\text{-ING } (Y) \rangle$

where  $C_1$ ,  $C_2$ , and  $C_3$  are Ditransitive, Caused Motion, and Resultative Constructions, respectively.

### 2.1 How constructions work to derive "emergent" meanings

Let us see how constructions work by taking *Joe kicked Bill the ball* [= (1)a], for example, which instantiates Ditransitive Construction. According to Goldberg (p. 54), the meaning of this sentence is constructed in the way that the following diagram is a schematization of it.

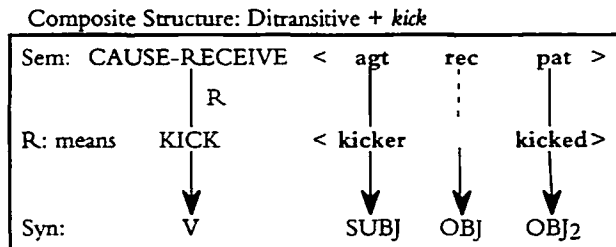

To annotate, the first row, Sem(antics), specifies the "constructional" meaning (ambiguously) assigned to  $F = X V Y Z$ . The meaning can be encoded by  $X \text{ CAUSES } Y \text{ TO RECEIVE } Z \text{ BY } R$ , or

2. For relevant definitions of (grammatical) construction, see Lakoff (1987), Langacker (1987, 1991a, 1991b) in addition to Fillmore *et al.* (1988) and Kay (1995).

approximated by translating it as “*X causes Y to receive Z by (means) of R*”, where *X* = agent, *V* = cause-receive, *Y* = recipient, and *Z* = patient. On the other hand, *kick* has semantics of its own, as the second row, *R*: means, specifies: its semantics is given as *X KICK Y*, where *X* = kicker, and *Y* = kicked. Integration of all of these specifications leads to the meaning, at Syn(tax), of *X kick Y Z* so constructed that “*Joe causes Bill to receive the ball (by means of kicking it (= the ball))*” is a close approximation of it.

## 2.2 Conceptual problems with Goldberg’s account

Goldberg is right, I presume, in claiming that the semantics (and the argument structure in the sense of Grimshaw 1990) of sentences in (1), (2), and (3) are not exhaustively determined by semantics of main verbs, and therefore there must be some other source which is responsible for the meaning constructed. For example, the meaning of *Joe kicked Bill the ball* (= (1)a) is approximated by translation “*Joe causes Bill to receive the ball by kicking it*”.

I am willing to agree with Goldberg (and disagree with lexical semanticists that she criticizes) in stressing that constructional meanings under discussion cannot be reduced to meanings of certain lexical items, e.g., *kick*, *fax*. But I disagree with her that there is nothing explanatory in stating, or stipulating that constructional meanings for Ditransitive, Caused Motion, and Resultative Constructions can be approximated by such schemas as  $M_1$ ,  $M_2$ , and  $M_3$  defined in (4) above. When we state, like Goldberg does, that form  $F = X V Y (P) Z$  has a constructional meaning  $M$ , which he claims can be approximated by  $M_1 = X \text{ CAUSES } Y \text{ TO RECEIVE } Z \text{ BY } V\text{-ING } Z$ , for example, nothing interesting is specified unless it is already accounted for why  $M$  should have such specification. This is the question of emergence, or of where constructional meanings come from, which I claim is unquestioned in assuming that grammatical construction is “pairing of form and meaning”, because the assumption precludes the question of emergence, or where such meanings like  $M$  above come from.

### 2.2.2 Arbitrariness in semantic representation

The last question sets up for my first conceptual objection to Goldberg’s construction grammar account. I, for one, find it “gratuitous” to assume meaning schemes like  $M_1$ ,  $M_2$ , and  $M_3$  in (4).<sup>3</sup> This is a (passable) convention that has a relatively long tradition, which we will have a chance to discuss afterwards, but this is also a good place to hide undesirable things, I suspect. To reveal this (rather controversial) point, let me ask a simple question, Is there any “independently motivated” reason to prefer (5) (=  $M_1$  in (4)) over other candidates in (5), on the one hand, and in (6)-(8)?

(5) 1.  $X \text{ CAUSES } Y \text{ TO RECEIVE } Z \text{ BY } V\text{-ING } Z (= M_1 \text{ in (4)})$

1'.  $X \text{ GETS } Y \text{ TO RECEIVE } Z \text{ BY } V\text{-ING } Z$

1''.  $X \text{ MAKES } Y \text{ RECEIVE } Z \text{ BY } V\text{-ING } Z$

(6) 1.  $X V Z \text{ AND } (X) \text{ CAUSES } Y \text{ TO RECEIVE } Z$

1'.  $X V Z \text{ AND } (X) \text{ GETS } Y \text{ TO RECEIVE } Z$

1''.  $X V Z \text{ AND } (X) \text{ MAKES } Y \text{ RECEIVE } Z$

(7) 1.  $X V Z \text{ TO CAUSE } Y \text{ TO RECEIVE } Z$

1'.  $X V Z \text{ TO GET } Y \text{ TO RECEIVE } Z$

1''.  $X V Z \text{ TO MAKE } Y \text{ RECEIVE } Z$

(8) 1.  $X V Z \text{ SO THAT } Y \text{ RECEIVE } Z$

I am very aware that it is possible to justify this position probably by appealing to so-called “semantic primitives”, but I claim that such justification is itself spurious: it is possible to postulate that CAUSE is a semantic primitive that GET, MAKE, and many others related concepts are possibly composed of. But the postulation is, as far as I can tell, more harmful than useful. Note, first of all, that the argument is double-edged: it may defend the attacked position, but it also attacks the reason why RECEIVE should

<sup>3</sup> This does never mean, I want to remark here, that diagrammatically account (using image-schemas) is superior, because it has as much gratuitous basis as this.

be preferred over HAVE ( $X$  CAUSES  $Y$  TO HAVE  $Z$  BY  $V$ -ING  $Z$ ), since it is likely that the concept RECEIVE is composed of HAVE. So, there is a contradiction to semantic primitive.

But, of course, it is of no use to replace  $M_1$  by  $X$  CAUSES  $Y$  TO HAVE  $Z$  BY  $V$ -ING  $Z$ . What to do when asked, Is HAVE primitive enough? Or, Is CAUSE primitive enough? Or, more seriously, why is CAUSE a primitive? Plainly, if they are primitives, they are so merely by definition.

Note that what crucially matters is not any use of such primitives, or simply concepts, but the way they are used. To reveal this, let me ask, What allows us to put such primitives as CAUSE, RECEIVE into sentence-like forms like  $X$  CAUSES  $Y$  TO RECEIVE  $Z$  BY  $V$ -ING  $Z$ , on the one hand, and predicate-like forms like CAUSE-RECEIVE< $X$ ,  $Y$ ,  $Z$ >, on the other? Or more adequately, why is it that they have such "syntax"? Is it a claim for "syntax of semantics", or "semotactics", if I could say so, to assume that semantic primitives "must" be arranged in such and such way? I will return to this issue later.

In any case, Goldberg's construction grammar account assumes, I claim gratuitously, that formats in small capitals like  $M_1$ ,  $M_2$ , and  $M_3$  "represent" (or at least "characterize") a way  $F = X V Y Z$  means something. But the conventionalized use of small capitals, I claim, is a mere "notational trick", though it has a long tradition which dates back to Generative Semantics.<sup>4</sup> In my opinion, the convention is so dangerously misleading that we should stop assuming as soon as possible, since its careless use inevitably leads to the absurdity that I specify below.

Think of what the semantics of (9)a will be (represented or approximated) in terms of small capitalization under discussion. According to Goldberg's account, it is (10)b, isn't it? But, if (10)b is to represent the meaning of (9)a, then what would the semantic representation of (9)b be given as?

- (9) a. Joe kicked Bill the ball.  
 b. Joe caused Bill to receive the ball (by kicking it).  
 (10) a. JOE KICKED BILL THE BALL  
 b. JOE CAUSED BILL TO RECEIVE THE BALL BY KICKING IT;

I believe that it is obviously (10)b. Here begins the absurdity. It follows that (9)a and b have the same meaning. But note that it also follows (10)a = (10)b, because if (10)b represents the meaning of (9)b, (10)a must represent the meaning of (9)a in the same way. As a consequence, there is no difference in meaning between (9)a and (9)b. Is this really what we have wanted to show? I believe not.

Do semantic forms like (10)a, b, or more generally,  $X$  CAUSES  $Y$  TO RECEIVE  $Z$  BY  $V$ -ING IT really "represent" one of the meanings that  $X V Y Z$  have ambiguously? I think not. The reason is almost obvious: paraphrases, or more adequately translations, are not representations.<sup>5</sup>

Once it turns out that what is encoded by  $M_1 = X$  CAUSES  $Y$  TO RECEIVE  $Z$  BY  $V$ -ING  $Z$  is not anything but the meaning of sentence  $G = "X$  causes  $Y$  to receive  $Z$  by  $V$ -ing  $Z"$ , a question immediately arises: Why the meaning of  $F = X V Y (P) Z$ , if categorized as Ditransitive Construction, can be translated by such  $G$ ? **This is exactly the question that we have first to account for.**

Most contemporary analyses of syntactic phenomena are victims of this trick of small capital notation, which seems to have begun since Lakoff (1970) through partial success of generative semantics in late 60's and early 70's. To cheat this trick, a quite sticking one, I want to remark as follows: the meanings of (9)a and b are not represented by (10)a and b, which are at best awkward translations of what (9)a and b mean, though almost virtually nothing is known about "how" they mean what they mean.

By this remark, I am trying to confirm, or reconfirm, a simple fact of trivial sort: forms, surface

4. According to Harris (1993), this notational convention began when Lakoff, motivated by the vexing fact that English has no verb *aggress*, at least as a surface form, while it has *aggression*, proposed, in *Irregularity in Syntax* (his Ph.D. dissertation, published later as Lakoff (1970) under the same title), an abstract, "underlying" verb denoted by chance by AGGRESS.

5. I suspect this is also true of the status of "image-schemas" in the sense of Lakoff (1987), and "imagery" in the sense of Langacker (1987, 1991a, b). I agree that what is called meaning is usually accompanied by imagery, if not images, of various sorts. But this does not entail that image schemas, or imagery, "constitute" meaning, even if they may "guide" meaning construction, by "monitoring" it. It seems very likely to me that image-schemas do not represent meanings of linguistic expressions. Rather, they have meanings of their own, and they happen to "translate" the meanings of linguistic expressions.

or deep, are themselves expressions of meanings. My real intent is more than this, however: more radically put, I suggest that **forms are themselves meanings** rather than mere expressions of them.

Examined from this point of view, it is clear that Goldberg's account fails to provide account of an important point: Why is it that the meaning of  $F = X \ V \ Y \ (P) \ Z$ , or more adequately the "interpretation of  $F$ ", denoted by  $\mathcal{I}(F)$  hereafter, is so approximated that the meaning of another form  $G = X \ \text{causes } Y \ \text{to receive } Z \ \text{by } V\text{-ing } Z'$  (where  $Z'$  is usually realized as *it*) is an "awkward translation" of  $\mathcal{I}(F)$ ? There is circularity in Goldberg's account here. Note that it is circular to answer the question by saying that  $M_1 = X \ \text{CAUSES } Y \ \text{TO RECEIVE } Z \ \text{BY } V\text{-ING } Z'$  is the meaning of  $G$ . Note that  $M_1$  is the meaning of  $G$  only by the notational convention assumed. So, there is nothing accounted for in small capitalizing it.

It is clear that Goldberg's construction grammar account no longer says anything about the semantics of syntactic form(ation)  $F = X \ V \ Y \ Z$  once it is disallowed to make reference to such constructs  $M_1 = X \ \text{CAUSES } Y \ \text{TO RECEIVE } Z \ \text{BY } V\text{-ING } Z$ . But this is not a good reason to assume one. There is indeed a better way to specify constructional meanings. To anticipate, let me sketch it briefly here. Take  $F = X \ \text{fax } Y \ (\text{to}) \ Z$  for example. Such stipulated forms like  $M_1$  are dispensable only if we are entitled to say that the  $\mathcal{I}(F)$  is "based on"  $G' = X \ \text{send } Y \ \text{to } Z$ , on the one hand, and on  $G'' = X \ \text{give } Y \ \text{to } Z$ , on the other, assuming that  $G'$  is itself based on  $G''$ . To put schematically (and somewhat misleadingly), the problem of constructional meanings of  $F$  will be solved only if it is allowed to replace *send* by *fax* in the context  $F = X \ \text{send } Y \ \text{to } Z$ , though this "transformational" rule explains nothing but a simple fact that there exists a class of grammatical phenomena which the transformational rule may describe with certain adequacy. Of course, our interest is the question of why there is, or should be, such class of phenomena in grammar.

### 3 Brief Introduction to Pattern Matching Analysis

We have seen so far that Goldberg's account explains nothing about the origin of constructional meanings, mainly because constructions are defined as pairs of forms and meanings, because her account is not an account of the reason why  $X \ V \ Y \ Z$  is associated to some meaning  $M$  approximated by translating it by " $X$  causes  $Y$  to receive  $Y$  by  $V$ -ing  $Z$ ".

It is unreasonable and irresponsible, however, to merely note that construction-based account like Goldberg's is inadequate on this ground. Indeed, her study reveals a lot of interesting things about construction effect, especially their network. I merely note here that there are still a lot of other things to be done, especially about what she takes for granted. We need alternative accounts for such matters.

Our problem is thus whether we can provide an alternative account better than, or as good as Goldberg's account without relying on spurious translations like  $X \ \text{CAUSES } Y \ \text{TO RECEIVE } Z \ \text{BY } V\text{-ING } Z$ . I believe this is possible, but let me remark that it is hardly possible unless we give up the idea of representing meanings of sentences in terms forms other than themselves, let alone such spurious translations.

This requirement, which we may dub **no deep(er) representation requirement**, may seem somewhat too severely restrictive, though, because what it requires is to regard and treat surface forms as direct (expressions of) meanings by themselves, without appealing to abstract structures, semantic or no, behind them. What we are entitled to do is make generalizations from surface distribution of forms, investigate relationships among surface forms, not relationship between forms and their meanings, actual or potential. This requirement is apparently incompatible with definition of constructions as form-meaning pairs, because, even if we want to generalize over meanings, it is not allowed to talk about meanings without reference to surface forms. But there is a simple solution. It is sufficient to think that what we call constructions are not really form-meaning correspondences, but rather higher order properties of form-form correlations correlating with meaning-meaning correspondences, which the distribution of surface forms is a manifestation or symbolization of.

But it turns out that any attempt at elaboration of even such a fairly simple idea demands much, if not too much, groundwork. Indeed, we need a conceptual tool that is powerful enough to dispense with constructions as form-meaning pairs altogether. We need thus a tool to facilitate us to analyze such form-form correspondences as manifestations of meaning-meaning correspondences. The analysis of this kind of relationships is what a method that I have been developing under the

name of **pattern matching analysis** (Kuroda 1996, in preparation), which was inspired largely by Lakoff's (1993) "cognitive phonology", a construction-based approach to phonological phenomena, though I have to admit that I do not adopt Lakoff's original idea of (phonological) constructions as "two-level rules" (in the sense of Karttunen 1993) which associate representations at different "levels". This is because I think it is possible to dispense with the idea of "underlying" representation, even for phonological/morphological phenomena, for the same reason that (grammatical) constructions in the sense of Goldberg are, as I have argued, not association of surface forms to underlying meanings at all. More deeply, I think that it is possible to dispense with the idea that there is a level of representation that is responsible for "pure" representation of meanings, or semantic representation. Such a view of forms/meaning relation smells is quite problematic. Rather, I want to hold, every linguistic units are form-meaning associations since the deepest level, if any. So, it is conceptually vacuous to assume that there is a single level that pure meanings exist without being put in certain forms. No such "transcendental", "impenetrable" level of representation is necessary. Indeed, such an idea is already contradiction with cognitive credo that meaning is based on bodily experiences (Lakoff 1987, Johnson 1987). Bodily experiences, linguistic or not, are themselves certain sort of forms, I hold. So, pure representation of linguistic meaning without being put into linguistic form is unthinkable; it is as unthinkable and as absurd as the library in Babel. There are a lot of meanings that linguistic forms cannot, or hardly can, express. But, my point is that if some meaning is not in linguistic form, it is no longer linguistic meaning, either. See Kuroda (in preparation) for more detailed discussion.

In any way, pattern matching analysis is designed to serve as a good method to do with correlations among surface forms as reflections of hidden meaning-meaning correlations. The following discussion in this section is devoted to a short introduction to the method that I propose.

### 3.1 Relevant details of pattern matching

As we will see below, pattern matching analysis is so-called because it crucially relies on the notions "patterns" and their "matching". As noted above, it provides a useful method to explore into correspondences among surface forms (with implicit semantics) under some crucial assumptions that I specify in the following.

In this analysis, surface forms are everything we are entitled to talk about. This is because, somewhat controversially, linguistic forms and their meanings are not distinguished. It tries to cleanse linguistic analysis of as many gratuitously "abstract" representations, semantic or syntactic, formal or conceptual, as possible. Such abstract representations may not be exploited for "explanatory" purposes, though they are likely to be utilized for "descriptive" purposes. From this comes a principle: no "underlying" forms are posited for syntactic or semantic or any other kinds of representation. In pattern matching view, if there are something like underlying forms, they are merely special kind of surface forms, or more exactly "potential components" of them. Roughly, the notion of linguistic "levels" is replaced by that of "scales", or "size".

Given a rather loose idea of syntactic patterns as being something like complex associations of a variety of properties, formal and conceptual, we need furthermore the notions of "(partial) matches and mismatches" between patterns to state form-form correspondences in terms of pattern matching.

Given two patterns  $F$  and  $G$  such that  $F = ABCD$  and  $G = ACBD$ . The correspondence between  $F$  and  $G$  is described (rather than accounted for) in terms of pattern matching under "optimization of partial mismatches". A pair of patterns match exactly if and only if all parts of them match with each other. So, quite trivially, a pattern exactly matches only with itself. Virtually all correspondences involve at least one partial mismatches, since they are relations between "different" patterns. Such mismatches need be "optimized". We assume two (and presumably only two) principles of optimization, specified as follows.

#### (11) Principles of Pattern Matching Optimization:

- A. Maximize the number of partial matches
- B. Minimize the number of partial mismatches

Under these assumptions, the correspondence between  $F = ABCD$  and  $G = ACBD$  has two ways of optimization of partial mismatches, as illustrated as follows. (12) illustrates one way of optimizing partial mismatches, relative to subpattern  $B$ , whereas (13) illustrates another, relative to

subpattern C.

(12) F: A • B C D

× ×

G: A C B • D

(13) F: A B C • D

× ×

G: A • C B D

where only partial mismatches are indicated by inserting “×” between them, assuming that partial matches are default.

A special kind of subpatterns, called “phantoms”, symbolized by “•”, plays a crucial role in optimization of mismatch resolution. We assume that phantoms match any subpattern. For more details of pattern matching, especially as to optimization procedure, phantoms, see Kuroda (1996, in preparation).

What pattern matching analysis assigns to sentences are not “constituent structures”, or “phrase markers”. For one thing, trees, in mathematical sense, are not powerful enough to characterize properties of syntactic structures properly. Syntactic structure, if anything, is a “web” of units, in which units communicate with each other. Hierarchical structure is apparent, and more appropriately an “emergent” property out of the complex interactions among units. For another, we do not need, at least for practical purposes, any constructs but sequences of units of arbitrary sizes, as far as they can be composed by “superposition”. In this crucial respect, pattern matching analysis can share insights with (somewhat misleadingly called) “autosegmental”, or more appropriately “multiplanar” theory of representation.<sup>6</sup> In agreement with the autosegmental view, I contend that a well-designed system of syntactic and semantic operations on strings can handle as successfully as systems of operations on phrase-marker trees, and whatever looks like them. Syntactic patterns, which we understand are form-meaning pairs, are sequences of certain units on different “planes”. Superposition, based on principles of matching, of such patterns over each other results in complex structures. On this view, we can dispense with trees altogether. I will return to this issue in the last section.

### 3.2 Illustrating pattern matching

For illustration, let us consider the correspondence between (14)a and b.

(14) a. They loaded bricks in(to) the truck.

b. They loaded the truck with bricks.

Incidentally, (14)a meets Goldberg’s definition of caused motion construction. The status of (14)b in Goldberg’s account is unclear, however. As far as semantics is concerned, it is analogous to ditransitive construction, but its syntax is different. The following variation is deviant.

(14) b’. \*They loaded the truck bricks.

Interestingly, verbs like *provide*, *supply* began to allow both patterns, as illustrated below, at least in recent usage.

(15) a. I can’t *provided* you ?(with) everything.

b. He *supplied* the people ?(with) food and drink.

This fact suggests that there is a super class of ditransitive construction, which I suspect is of the form  $F = X V Y (P) Z$ , where  $P$  may be null. If  $P = with$ , it sanctions (14)b. Additionally, if  $P = of$ , it sanctions the following patterns.

(16) a. The accident *deprived* him *of* all of his fortune.

6. For autosegmental phonology, see Goldsmith (1979) and subsequent works. For autosegmental morphology, which is more relevant, see McCarthy (1981) and subsequent works.



- b. You must *divest* yourself of pride. (LDCE, *divest*)<sup>7</sup>
- c. God *deanse* me of my wickedness. (LDCE, *deanse*)
- d. The robbers *stripped* him of all he possessed. (LDCE, *strip*)

Surely, this pattern is deviant; but note that the act of depriving is the reverse of that of giving. In other words, they have something in common: in some abstract level, and I suspect that such commonality is symbolized by this class of constructions.

Let us return to the original problem. Our concern is with the form-form correspondence (with implicit meaning-meaning correspondence) of (14)a and b. How can it be characterized? My proposal is given in (17) and (18), where partial mismatches are optimized, in two ways, to meet the two principles stated in (11).

(17)	F:	they	loaded	bricks	in	the truck	•	•
				×	×		×	×
	G:	they	loaded	•	•	the truck	with	bricks
(18)	F:	they	loaded	•	•	bricks	in	the truck
				×	×		×	×
	G:	they	loaded	the truck	with	bricks	•	•

Here, I want to reserve myself from claiming which is the correct one, alluding that it is possible that both are correct. What I can suggest here is simply that if *F* is deemed basis, *G* manifests, in both (17) and (18), relative “advancement” of *the truck*, a “container” to be filled.

What the optimized pattern matching in (17) embodies are: there are partial mismatches between *F* and *G* with respect to *bricks*, *in*, *with*, and there are partial exact matches with respect to all other pairs.

A few remarks are in order. Correspondences like the last one claim no “derivation” from one form to the other, since in (17) and other cases, none of *F* and *G* is the “underlying” form of the other. Furthermore, correspondences like this by no means claim that *F* and *G* are synonymous sentences. The contrary is true: since *F* and *G* are different forms, they can never be identical in meaning, either. This is exactly because forms, we assume, are themselves meanings, rather than imprecise “expressions” of them.

Under those assumptions made so far, the remainder of this section is devoted to a preliminary discussion of my alternative analysis of the construction effect.

### 3.3 Constructions from the perspective of pattern matching: A preliminary analysis

As noted above, one of our questions is this: How to limit on the proliferation of formats like those in (4), and (5)-(7), which are proposed one after another to represent meanings of sentences? This is a serious problem that deserves intensive exploration, I believe.

To achieve this, I claim that what we really need is to investigate form-form correspondences (ff correspondence for short) aiming at probing the hidden meaning-meaning correspondences (mm correspondence for short) rather than the notion of construction as form-meaning correspondence. We will see that the form-form correspondence could be successfully handled in terms of pattern matching, described in some detail below.

With this question in mind, let us compare (19), (20), and (21). In (19) alone, pattern matching is subject to Goldberg's format, where *M* replaces Goldberg's Sem, and *F*, her Syn, where CAUSE and TO RECEIVE are replaced by MADE and HAVE, respectively.

(19)	M:	X	MADE	•		Y	HAVE	Z	BY	V-ING	Z
		×	×			×		×	×	×	×
	F:	Joe	•	kicked		Bill	•	the ball	•	•	•

7. Here and elsewhere, LDCE abbreviates *Lodman Dictionary of Contemporary English* (1978).

(20)	M:	X	V	Z	AND (X')	MADE	Y	HAVE	Z
				×	×	×	×	×	
	F:	Joe	kicked	•	•	•	•	Bill	• the ball
(21)	M:	X	V	Z		TO MAKE	Y	HAVE	Z
				×		×		×	
	F:	Joe	kicked	•		•	Bill	•	the ball

It is important to note first that in the three *M-F* pairs, *M*'s are virtually equivalent to (5), (6), and (7).

Note next that forms at *M* (= Sem), in terms of pattern matching, can (and in my opinion should) be regarded as surface forms (or rather formations) rather than abstract formats of semantic representation, which Goldberg and many other "conceptualist" linguists have in their minds. I provided above a few arguments against such a view of linguistic form and meaning, based on the fact that translations are not representations. A view of language is a "simplistic" view if it takes it for granted that forms and their meanings are separable. Careless adoption of such a view was a greatest error of generative semantics, I suspect. Language is so complex a system that such an intuition leads us to unexpected errors.

So, more appropriately, what we investigate here is rather the comparison among such "form-form correspondences" as illustrated in (22), (23), and (24), each of which is a description of partial matches and mismatches between two surface patterns *G* (e.g., *Joe made Bill have the ball by kicking it*) and *F* (e.g., *Joe kicked Bill the ball*), where only partial mismatches are marked by inserting "×".

(22)	G:	X	made	•			Y	have	Z	by V-ing	Z'	
			×	×				×		×	×	×
	F:	X	•	V			Y	•	Z	•	•	•
(23)	G:	X	V	Z	and (X')	made	Y	have	Z			
				×	×	×	×	×				
	F:	X	V	•	•	(•)	•	Y	•	Z		
(24)	G:	X	V	Z		to make	Y	have	Z			
				×		×		×				
	F:	X	V	•		•	Y	•	Z			

This difference between the two descriptions embodied by (19), (20), and (21), on the one hand, and by (22), (23), and (24), on the other, is not notational but conceptual. To see this, let me point out that Goldberg's conception and our alternative are crucially different in the following respect.

- (25)
- i. (19), (20), and (21) claim that interpretation of surface forms is a "mapping" from the domain of forms, *F*'s, onto that of meanings, *M*'s, on the one hand, whereas:
  - ii. (22), (23), and (24) claim that the interpretation of surface forms is not such a mapping at all; rather, it is a mental process that could not be equated with "translation", assuming that the possibility of translation should be accounted for in terms of "spreading activation" theory.

It will be relevant here to note that schemes of the first sort presuppose a theory of "cognitive mapping" in the sense of Fauconnier (1995, 1997), on the one hand, and Lakoff (1990), on the other. To see this, observe that Goldberg's construction grammar account in fact embodies a mapping theory in which elements at Sem(antics), or in the domain of meanings are mapped to elements at Syn(tax), or in the domain of forms.

Of course, whether there is or is not such mapping is not a real problem, because mathematical concept of mapping is so powerful to be able to formulate any complex aspect of anything which

exhibits regularity. What really matters is an ontological claim accompanied with it: Are there really “domains” exclusively of forms and of meanings, which, by definition, are independent of each other? In my view, postulation of such domains is itself a convenient fiction, which is too powerful to lead to some empirically inadequate consequences.

### 3.4 What the distribution of phantoms suggests

Let us introduce the notion of “fusion of phantoms”, which we may believe reflects, or even symbolizes (in the sense of Langacker 1991a, b), the “fusion of acts/actions” occurring in semantic dimension. Several phantoms “fuse” themselves into a single phantom on the following condition.

- (26) Phantoms can fuse into one when they cluster, or in other words, constitute a continuous (and probably coherent) grammatical unit.

Based on this condition, we arrive at the correspondences in (27), (28), and (29), where respective phantoms in (22), (23), and (24) are fused.

(27)	G:	X	made	•		Y	have	Z	by	V-ing	Z
			×	×			×			×	
	F:	X	•	V		Y	•	Z			•
(28)	G:	X		V	Z	and	(X)	made	Y	have	Z
							×		×		
	F:	X		V			•	Y	•	Z	
(29)	G:	X		V	Z		to	make	Y	have	Z
							×		×		
	F:	X		V			•	Y	•	Z	

Here, phantom fusion increases “matching index  $M$ ”, defined as the ratio of “number of matches/number of units” so that  $M(22) = 2/9 \approx 0.222$ ,  $M(23) = 4/9 = 0.444$  (or  $4/8 \approx 0.5$ ), and  $M(24) = 4/7 = 0.571$  (or  $4/8 = 0.5$ ), whereas  $M(27) = 3/7 \approx 0.428$ ,  $M(28) = 3/5 \approx 0.6$ , and  $M(29) = 3/5 = 0.6$ .

### 3.5 Measuring the strength of similarity by means of “matching index”

As we have seen just above, pattern matching analysis provides “matching index”  $M$  defined as the ratio of “number of matches/number of units” (depending on scales) as a useful method to measure the “cost” in matching. Indeed,  $F$ - $G$  matching is more “costly” in (27) than in (28) and (29), since there is no reason not to assume that each partial mismatch costs the same.

This statement can be justified on a quantitative basis, not on a intuitive, qualitative one, for we have a quantitative method to evaluate the “strength” of correspondence by using Pearson’s correlation coefficient on the assumption that syntactic patterns can be so encoded that they have unique vectorial representations in an  $n$ -dimensional space. What we have to do is calculate inner products of two vectors indexing syntactic patterns. This procedure is sure to result in making a “map” of patterns.

Under this provision, we can observe that  $F$ - $G$  matching in (27) contains 4 partial mismatches, namely (*made*, •), (•, *V*), (*have*, •), and (*by V-ing Z*, •), whereas (28) and (29) contain 2 mismatches, namely (*Z and (X) made*, •) and (*have*, •), and (*to make*, •) and (*have*, •), respectively. What is implied by this is that, of the three correspondences, (28) $G$  and (29) $G$  are more “similar” to  $F = X V Y Z$  than (27) $G$ . Furthermore, this property can be translated in terms of “motivation”. On this ground, we may hypothesize that this implies that (28) $G$  and (29) $G$  are more strongly “motivated” than (27) $G$ .<sup>8</sup>

8. This can be seen as the distribution of phantom clusters. In  $F$ -form, phantoms cluster two locations, namely  $V\_Y$  and  $Y\_Z$ , whereas in  $G$ -form, they cluster three locations:  $X\_V$ ,  $Y\_Z$ , and  $Z\_•$ . Generally speaking, pattern matching is less costly when phantoms are localized and clustered.

3.6 Fusion of causally chained units

The notion of phantom fusion gives us a hint to figure out why constructions under discussion take the very form  $X V Y Z$ , which is a question that is not even addressed in Goldberg's construction grammar account. With this point in mind, let us look closely at (6) and (7), repeated here for convenience, but without small capitalization, since they are no longer intended as semantic contents.

- (6) 1.  $X V Z$  and (X) made Y have Z
- 2.  $X V$  and (X) made Y move Z
- 3.  $X V$  and (X) made Y become Z
- (7) 1.  $X V Z$  to make Y have Z
- 2.  $X V$  to make Y move Z
- 3.  $X V$  to make Y become Z

It is interesting to note that, given that the sequences " $Z$  to make/ $X V Z \_ Y \dots$ " and " $Z$  and (X) made/ $X V \_ Y \dots$ " are reducible, we have at least four reasons, A-E, not to have Goldberg's formats as ones to specifying the meaning of relevant constructions.

A. (6) is preferable when we take into serious consideration the possibility of "reference transfer", by which that  $X$  refers metonymically to the preceding clause,  $X V$ , rather than the usual antecedent  $X$ . By contrast, why  $X$  disappears hardly matters. This transfer naturally corresponds to the notion of **clause fusion**, perhaps "symbolizing" **event fusion**, which takes place when phantoms are reducible, and plausibly they are reducible only when they are causally "amalgamated" rather than "chained". Two events,  $E_1$  and  $E_2$ , are causally "chained" if and only if we interpret that  $E_1$  caused  $E_2$ , but not vice versa. Events  $E_1$  and  $E_2$  are amalgamated if and only if they are mutually causally chained, and they are conceived of as happening simultaneously (at least in the relevant construal).

B. The remaining problem in A is why  $Z$  is reduced in (6)1 (and (7)1). But this could be accounted for when we take into consideration the possibility that the disappearance of  $Z$  is the effect of what is called "right-node raising" (RNR) of  $Z$  in generative tradition.<sup>9</sup> So, (6) is preferable also in this respect. RNR is the kind of syntactic phenomena illustrated as follows.

- (30) a. Ann is a sister of, and Bill denies that he is a brother of, *Cynthia*.
- b. Andy likes, and Bill dislikes, *all songs by Sex Pistols*.

But it is also necessary to note that phantom fusion is not subject to the exact form of RNR, because the exact form of RNR would be (31)G, as matched against (31)F, where  $C_1$  is "fused" into  $C_2$  in G.<sup>10</sup>

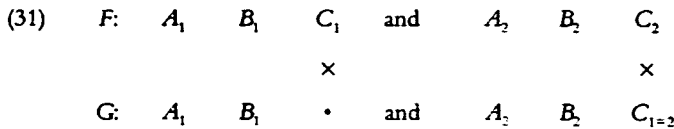

If RNR-like analysis of ditransitive construction is correct, then we may arrive at the pattern matching illustrated as follows.

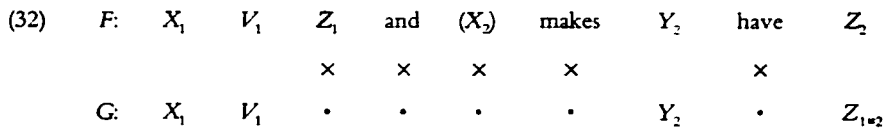

where phantoms are not fused. Crucial in ditransitive, caused-motion, and resultative constructions are: (i)  $A_2$ , coreferential with  $A_1$ , cannot be overt (or obligatorily null); (ii)  $Y_2$  is such anomalous constituents as *makes Y have*, *makes Y be*, and *makes Y become*; and finally, (iii) *and* is absent.

C. Furthermore, pattern matching based account of emergent senses can avoid the implausibility

9. For more information about right node raising, see McCawley (1988) and references cited therein.  
 10. The analysis here is conceptually compatible with McCawley's (1988) analysis of RNR in terms of fusion.

that Goldberg's account of ditransitive construction, for example, is not free from. Her account does not provide, in a real sense, the motivation for  $X V Y Z$  to have the meaning obviously related to  $X$  give  $Y Z$ , since the sense of *give* is decomposed into parts, namely  $X$  CAUSE  $Y$ , and  $Y$  (TO) RECEIVE  $Z$ . Pattern matching analysis, however, is even able to provide motivation for it, because it is exclusively based on relations among surface forms. Note that there is no difficulty in replacing (28) and (29) by the following correspondences.

(33)	G:	$X$	$V$	$Z$	and	$(X')$	gave	$Y$	$Z$
							×		
	F:	$X$	$V$				•	$Y$	$Z$
(34)	G:	$X$	$V$	$Z$			to give	$Y$	$Z$
							×		
	F:	$X$	$V$				•	$Y$	$Z$

where there is only one occurrence of partial mismatch between  $F$ - and  $G$ -forms. This is a result far from trivial, I believe.

Moreover, (6), and (7) as well, is preferable when we take into serious consideration the problem of why "*have/... Y \_\_\_ Z*" does not appear at surface. It is interesting to note, in this respect, that, in 2 and 3, *move* and *become* are prevented from freely surfacing. This feature is only expectable to verbs that take bare infinitive as  $W$  of  $X V Y W$ , and is not expectable for formats like " $X$  causes  $Y W$ " because *cause* requires *to*-infinitive as  $W$ .

D. Admittedly, (6) is preferable also when we take into serious consideration the position of tense-bearing elements ( $-s$ ,  $-ed$ ), albeit a morphological matter, since we can resegment and recategorize the result of right-node raising of  $Z$  to the end of sentence, as what (35)G and  $G'$  specify, by postulating that matching scale has shifted.

(35)	G:	$X$	[ $V$	$Z$	and (X) give	] +T	$Y$	$Z$
	$G'$ :	$X$	[ $V$	•	to give	] +T	$Y$	$Z$
						×		
	F:	$X$	[ $V$	•	]	+T	$Y$	$Z$

where T stands for the element (or feature) to be realized as  $-s$ , or  $-(e)d$ , for example.

Note that most of the properties used in A-D to argue for (6) (and (7)) are "surface" constraints, and therefore we cannot expect them to be true of such seemingly "abstract" semantic forms as Goldberg's  $X$  CAUSES  $Y$  TO RECEIVE  $Z$  BY  $V$ -ING  $Z$  (especially when they are "(small) capitalized").

The last point forms, I argue, one of the strongest arguments against the notion of constructions as form-meaning pairs. Constructions have still crucial properties as form-form correspondences. So, I rather claim that constructional "effects" emerge when meanings of surface forms are correlated through the hidden channel of meaning. Based on these, I believe it is not an exaggeration to say that pattern matching analysis is a method to analyze a network of linguistic form(ation)s rather than linguistic forms, or formations, *per se*. This is because it makes use of, in a very sophisticated and principled way, direct or indirect "based on" relations among form(ation)s.

#### 4 Pattern Blending Account of Constructional Meanings

By discussions so far, I do not intend to revive a version of "transformational" account of the construction effect. What I have done so far are merely a preparation for a better analysis of the construction effect that follows. So, the analysis with reference to right-node raising is not what I am trying to replace the Goldberg's (1995) construction grammar account by, partly because right-node raising is itself a questionable phenomenon, and partly because I have no intention to propose a transformational account. My real attempt is to replace accounts like Goldberg's on which the existence of constructions in a grammar is taken for granted by alternative accounts on which the existence of them is also accounted for rather than stipulated. My alternative is, roughly, based on the notion of **pattern blending**, through which two patterns and are blended into one. This is a

revision of the “transformational” account that I have noted above. Recall that constructional meaning of  $F = \textit{Joe faxed Bill the letter}$ , for example, could be described, rather than accounted for, only if a set of transformations is posited such that one of them operate on another form  $G = \textit{Joe sent Bill the letter}$  to derive  $F$  by replacing *sent* by *fax*. I admit that this is fairly good as a first approximation, but it is also clear that it accounts for nothing fundamental, since the motivation of such transformation, or the reason why such transformations exist, is not accounted for at all. I will not deny that my account in terms of pattern blending is, in a sense, a mere sophistication of such transformational account, but such effort of sophistication can, or should, be free from any accuse, I claim, as far as it provides insight. Roughly, my account goes as follows:  $F = \textit{Joe faxed Bill the letter}$  is a “blend” of two patterns,  $D = \textit{Joe faxed the letter}$  and  $E = \textit{Joe sent Bill the letter}$ , in that  $F$  “inherits” the syntax and semantics of both of them, though partially and selectively: *sent* is “overridden” by *fax*, *Bill* has no counterpart in  $D$ . Despite these peculiarities, pattern blending, I want to stress, can be understood as a process of “symbolization”, at least in the sense of Langacker (1987, 1991a, b), of a causal unity between the two events that  $D$  and  $E$  denote. More explicitly, such a conceptual unity is symbolized by syntactic and semantic “fusion” of  $D$  and  $E$  into one  $F$ .

This is a rough sketch of what I will provide as a final version is my analysis. I believe this is already clear enough, at least conceptually, but it will also be more appropriate to touch on Fauconnier’s (1997) discussion of the relevant phenomena in terms of “conceptual blending”, since it is fair to state that my idea of pattern blending is partly a reinterpretation of Fauconnier’s version of blending. So, let me begin by reviewing Fauconnier’s proposal.

#### 4.1 Fauconnier’s alternative account

Fauconnier’s (1997) attempts to provide an alternative account of the construction effect in terms of “conceptual blending”, which he claims serves as “one important cognitive process that drives some of this creativity [in producing new meaning and novel conceptualization] and depends crucially on cognitive mappings between mental spaces” (p. 149).<sup>11</sup> For definition of blending, let us cite from Fauconnier (1997, p. 149). He states as follows:

Blending is in principle a simple operation, but in practice gives rise to myriad possibilities. It operates on two input mental spaces to yield a third space, the *blend*. The blend inherits partial structure from the input spaces and has emergent structure of its own.

Under this informal definition, Fauconnier points out that “grammatical constructions [interpreted as pairings of forms and meanings] are blends, which are entrenched but evolve diachronically. The general driving force behind this phenomenon is the linguistic pressure to represent complex interactions of events by making maximum use of existing grammatical constructions” (p. 173).

Fauconnier analyzes, for example, Goldberg’s caused motion construction, exemplified by (36), as a pairing of the form “NP V NP PP” and the schematic meaning “*a* causes *b* to move to *c* by doing *d*” as specified in (37).

(36) The sergeant *waved* the tanks into the compound.

(37) NP V NP PP  
       *a* *d* *b* *c*

In (36), in fact, *wave* is used so that it is associated with emergent meaning: *wave* is inherently an intransitive verb which does not take object, though *wave at Y*, *wave for Y*, or *wave against Y* may be possible.

As a preliminary, Fauconnier suggests that the pairing of the form  $F = \textit{NP V NP PP}$  and the constructional meaning  $M = \textit{“a causes b to move c by doing d”}$  can be construed as an interconnection between two “mental spaces”, namely  $I_1$  and  $I_2$ , as illustrated in Figure 8.2

11. See also Fauconnier (1994) for more information of mental spaces theory.

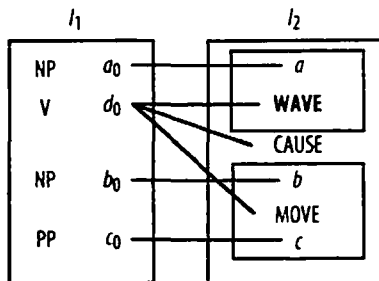

Figure 8.2

[Fauconnier's Figure 6.13 with slight modification of mine]

To  $I_1$  and  $I_2$ , Fauconnier gives the following definitions (p. 173).

(38)  $I_1$ : Input 1: the basic construction, found in many languages,  $[a_0 d_0 b_0 c_0]$ <sup>12</sup> where  $d_0$  is an action (e.g., throwing, putting) that causes motion and transfer of  $b_0$  from the agent  $a_0$  to some location  $c_0$ . It is expressed in English through the syntactic form: NP V NP PP [as in *John throws the ball to Susan*].

$I_2$ : Input 2: a causal sequence of the form:  $[[a \text{ ACTS}] \text{ CAUSES } [b \text{ MOVE } c]]$ .

It is noticeable that in Figure 8.2, multiple correspondences are treated as multiple connections. For example,  $d_0$  in  $I_1$  is connected to WAVE, CAUSE, and MOVE in  $I_2$ . This is a mental space theoretical way of stating that *wave* in (36) corresponds to complex predicate CAUSE-MOVE in Goldberg's caused motion construction, on the one hand, and the means of realization, R, on the other.

After this preliminary sketch, Fauconnier goes on to revise the interconnection illustrated in Figure 8.2. He replaces the figure by the interconnection illustrated as in Figure 8.3.

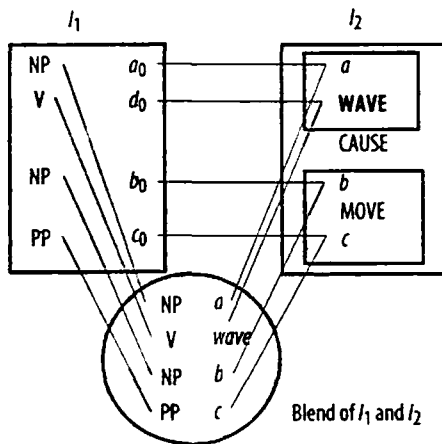

Figure 8.3

[Fauconnier's Figure 6.14, p. 174, with slight modification of mine]

where a new space, Blend (call this  $B$ ), is created, which is a space whose elements are (selective) blending of input spaces  $I_1$  and  $I_2$ .

#### 4.2 Conceptual problems with Fauconnier's account in terms of conceptual blending

Having seen some details of Fauconnier's blending account of construction effect, I want to make some remarks on his account.

It is clear that Fauconnier defines blending as an operation which is first and foremost "conceptually driven", and for this reason his blending account no more takes surface syntax seriously than Goldberg's account does. To witness, his  $I_2$ , which specifies the schematic meaning of the construction,

12. Fauconnier originally writes here  $a_n, b_n, c_n, d_n$ , which seems inconsistent.

is associated to no syntactic information. There is a complication, however: Is conceptual blending exclusively conceptual? Or, more specifically, Is formation of spaces like  $I_2$  independent of surface syntax?

Fauconnier talks as if “concept formation” that results in space construction of  $I_2 = [[a\ d]\ \text{CAUSE}\ [b\ \text{MOVE}\ c]]$  has nothing to do with syntactic formation. This is partly because abstract semantics like  $I_2$  have no faithful realizations at surface syntax. Witness the impossibility of the following sentence.

(39) \*The sergeant wave(d) caused the tanks move(d) into the compound.

Despite this fact, however, it is taken for granted that abstract semantics like  $I_2$  “approximate” meanings of sentences like (36). But why?

The fact that  $I_2$  has no faithful surface form is even utilized to argue for “pure” mental spaces like  $I_2$ , which, unlike  $I_1$ , lack syntactic information altogether. But what is it that guarantees that  $I_2$  approximates the exact meaning of (36), for example?

The assumption that  $I_2$  approximates the meaning of (36) is itself question-begging, and, I argue, as gratuitous as Goldberg’s assumption that meaning schemas like  $X\ \text{CAUSES}\ Y\ \text{TO}\ \text{RECEIVE}\ Z\ \text{BY}\ V\text{-ING}\ Z (= M_1)$  approximate meanings of sentences like *Ann faxed Bill the letter*.

If  $I_2$  approximates the meaning of (36), it is equally certain that other forms like the following should do.

(40)  $I'_2$ :  $[[a\ d]]\ \text{TO}\ \text{CAUSE}\ [b\ \text{TO}\ \text{MOVE}\ c]]$

$I''_2$ :  $[[a\ d]]\ \text{SO}\ \text{THAT}\ [b\ \text{MOVE}\ c]]$

But the status of  $I'_2$  and  $I''_2$  is different from Fauconnier’s  $I_2$  in one crucial point. These have respective faithful surface realizations because they are, by definition, meanings of the following sentences.

(41) a.  $X\ V\ \text{to}\ \text{cause}\ Y\ \text{to}\ \text{move}\ Z$

b.  $X\ V\ \text{so}\ \text{that}\ Y\ \text{move}\ Z$

This clarifies that the stipulation of abstract semantics  $[[a\ d]\ \text{CAUSE}\ [b\ \text{MOVE}\ c]]$  to account for blending is vacuous for the same reason that Goldberg’s abstract semantics like  $X\ \text{CAUSES}\ Y\ \text{TO}\ \text{RECEIVE}\ Z\ \text{BY}\ V\text{-ING}\ Z (= M_1)$  is vacuous.

To see how arbitrarily  $I_2$  is determined, it will suffice to look at the following diagram, which illustrates the “multiplicity” of conceptual linkage to  $I_2$ .

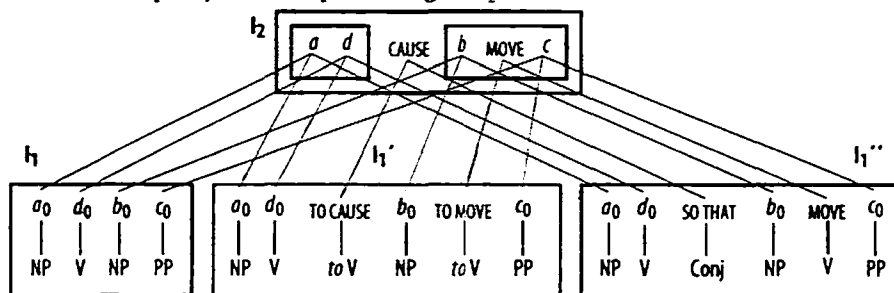

Figure 8.4

As we have seen, Fauconnier’s blending account crucially relies on the link between  $I_1$  and  $I_2$ , but, as this diagram reveals, there are many other form/meaning pairs, e.g.,  $I'_1, I''_2$ , that may play the same role as  $I_1$  does. It is trivial to note that (vacuously) blending  $I'_1$  and  $I_2$ , for example, never yields the blend that is in need. But this triviality should be contrasted with the effectiveness of blending  $I_1$  and  $I_2$ . Thus, if caused motion construction, for example, is indeed a blend of  $I_1$  and  $I_2$ , then it must be explained why  $I_1$  is selected, in exclusion of other form/meaning pairs, to mean  $I_2$ . This raises a serious problem, What makes  $[a\ d\ b\ c]$  the blend of  $I_1$  and  $I_2$ ? Or, in other words, why is it that  $[a\ d\ b\ c]$  is not a blend of  $I'_1$  and  $I_2$ , for example?

But it will be of no use to try to find the kind of answer that we are eager to know in Fauconnier’s account which ignores surface syntax altogether. The reason is simple: the real motivation for a specialized surface syntactic formation that we are looking for is lost as soon as the meaning of



$I_1$  is “translated into”  $I_2$ . If syntactic motivation is not accounted for, it is hardly true that construction effect is accounted for.

To summarize, Fauconnier’s blending account may be interesting as an “application” of mental spaces theory to syntactic phenomena, but it is by no means so much revealing in itself. This is partly because it is almost trivial that such powerful mechanism as mapping, unless restricted in some interesting way, can handle relevant phenomena. Even ignoring such triviality, Fauconnier’s blending account is no more explanatory than Goldberg’s construction account, at least as it stands, because it separates syntax and semantics rather than integrating them. In Fauconnier’s mental spaces theory, as well as in Goldberg’s construction grammar approach, constructions are considered as pairings between syntactic forms and semantic contents. But this idea is already a contradiction, since it fallaciously presupposes two impossible objects: one is syntactic forms without semantic contents, and another is semantic contents without syntactic forms. But we have already been led to realize that this makes no sense. Pairings between forms like *X waved Y Z* with semantics *X CAUSES Y TO MOVE Z BY WAVING AT Z* are, as noted above, really relations between two surface forms, namely *X waved Y Z* and *X causes Y to move Z by waving at Z*.

### 4.3 Alternative conception of blending

Considerations so far motivate alternative conception of blending. But the revision we need is not difficult to work out. Let me ask simply, What prevents us from conceiving of blending as one of surface forms and their meanings at the same time? This is exactly what I want to argue for in what follows under the rubric of **pattern blending**, in terms of which we can now attempt to account for how construction effects emerge from it.<sup>13</sup>

Our alternative tries to keep faithful to surface syntax by assuming that the emergent use of verbs like *wave* in examples like (36) is still a (unusual) way of realizing the relation *R* between  $S_1$  and  $S_2$ .

- (42)  $S_1$ : The sergeant *waved*  
       *R*: ...  
        $S_2$ : *X W* the tanks into the compound.

where *X* is the subject and *W* is the verb of  $S_2$ . Since *X*, *W*, and *R* are underspecified, a variety of expressions can realize them. Putting aside for the moment the realization of *W*, it is easy to see that such noun phrases as *the sergeant*, *he* (coreferential with “the sergeant”), and, importantly, *it*, *that* (taking  $S_1$  as a whole (or even its action component) as antecedent) may realize *X*. For *R*, we will have:

- (43) i. *R* = *and (as a result) he got, and (accordingly) he lead,*  
       ii. *R* = *(in order) to get, (in order) to lead, ...*  
       iii. *R* = *so that, ...*

But we may take steps further and conceive of pattern blending as a special means for realizing *R*. as a higher order symbolization in the sense of Langacker (1991a, b), which has, among other, the following properties.

Pattern blending is a special case of composition, in which two (or more) “overlapping” syntactic patterns are combined into one. More specifically, we conceive, for expository purposes, of *F* = (36) is a **blended pattern**, rather than a blended space, of patterns (44)*D* and *E*, the latter of which is schematization of more specific patterns like *E'* and *E''*.

- (36) *F*: The sergeant *waved* the tanks into the compound.  
 (44) *D*: The sergeant *waved*  
       *E*: The sergeant *W* the tanks into the compound  
       *E'*: The sergeant *got* the tanks into the compound  
       *E''*: The sergeant *led* the tanks into the compound

13. In some respects, my conception of pattern blending is also inspired by D. Bolinger’s syntactic blends (1961, 1967, 1977), though did not propose a mechanism explicit enough to carry out blending of patterns, or syntactic forms.

where we assume that *W* in (44)*E* is an abstract unit that need not (and probably cannot) be overt. We will see the exact reason later.

Our syntactically based alternative to Fauconnier's (gratuitously) conceptualist version of blending can be illustrated by the following diagram, as opposed to Fauconnier's Figure 8.3.

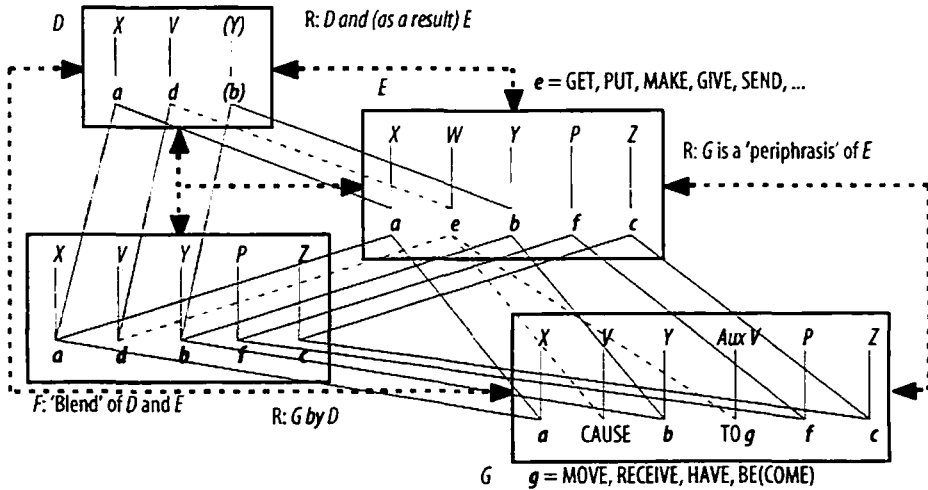

Figure 8.5

where *D*, *E*, *F*, and *G* are form-meaning pairs (and spaces of certain sort). This network claims that *F* is a "blend" of *D* and *E*, given  $D = X V (Y)$ ,  $E = X V Y (P) Z$ .

But specification in this diagram is insignificantly (and probably dubiously) redundant, since syntactic forms and their semantic contents are separated. Alternatively, we can make such form-meaning correspondences "implicit" by diagramming instead as follows.

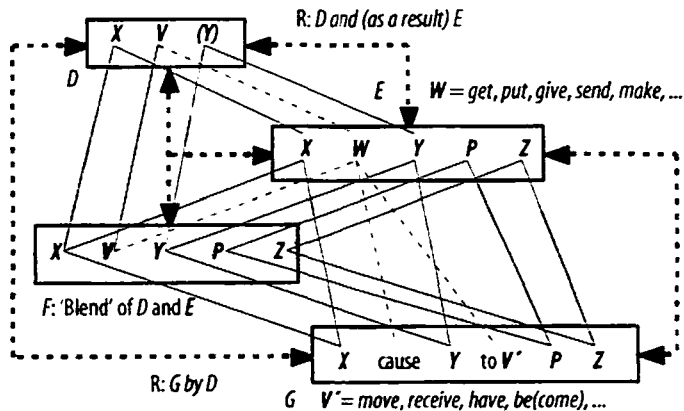

Figure 8.6

But even this diagram is less revealing, since it is still possible to reduce irrelevant informations.

#### 4.4 A note on the connection to "multiplanar" theories of representation

In this regard, it is helpful to relate the structure diagrammed in Figure 8.6 to what is called "multiplanar" representation in the literature of "autosegmental" morphology/phonology. Note that the relation of *F* to *D* and *E* in Figure 8.6 can be boiled down to a triadic relation, as diagrammed in Figure 8.7.

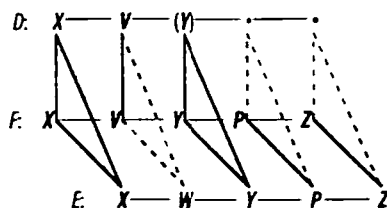

Figure 8.7

where solid lines indicate matching associations, and dashed lines mismatching associations. As illustrated, solid lines connect  $V$ ,  $P$ , and  $Z$  of  $F$  to  $D$ , on the one hand, and to  $E$ , on the other.

In diagrams like the one in Figure 8.7, the affinity between the two representational systems is obvious. If we follow the terminology in the literature of autosegmental phonology/morphology,  $D$  and  $E$  are “autosegments” located on different “tiers” or “planes”. Despite this affinity, the exact status of  $F$  is unclear. It is analogous, in some interesting respects, to what is called “skeleton”, but it also has properties as a result of “plane conflation”. I do not think that the affinity in question is superficial, but the last point may suggest an incompatibility between them.

#### 4.5 Construction effect emerges when syntactic/semantic override takes place

Operation of pattern blending, diagrammed in Figure 8.7, is made simpler and easier to handle, both conceptually and technically, than Fauconnier’s version of blending. But this is not the more interesting. Note that what is diagrammed in Figure 8.7 is exactly what the vertical composition of subpatterns,  $D$  and  $E$  into  $F$ , as illustrated in (45).

(45)	$D:$	$X$	$V$	$(Y)$	$\cdot$	$\cdot$
	$E:$	$X$	$W$	$Y$	$P$	$Z$
		$\Downarrow$	$\Downarrow$	$\Downarrow$	$\Downarrow$	$\Downarrow$
	$F:$	$X$	$V$	$Y$	$P$	$Z$

where “ $\Downarrow$ ” symbolizes the operator of “unification”.

(45) describes schematically how two patterns  $D = X V (Y)$  and  $E = X W Y P Z$  are blended into pattern  $F = X V Y P Z$ . We assume here that blending is a pairwise unification of all partial (mis)matches between  $D$  and  $E$ .

As is evident in this table, what makes blending different from simple composition is that “overrides” (e.g., of  $V$  over  $W$ ) are permitted. More specifically, blending (45) $D$  and  $E$  involves resolution of the following pairs of (mis)matches:  $\langle X, X \rangle$ ,  $\langle V, W \rangle$ ,  $\langle (Y), Y \rangle$ ,  $\langle \cdot, P \rangle$ , and  $\langle \cdot, Z \rangle$ . What is problematic is of course,  $\langle V, W \rangle$ , because other (mis)matches can be unified in usual way. It follows that blending is possible only if overriding  $V$  over  $W$  is successful. This necessitates that  $\mathcal{A}(V)$  is intensionally extended to include  $\mathcal{A}(W)$ .

It is important to note that we should have another blending scheme, as illustrated in (46), in addition to (45), because (45) is responsible for Caused Motion and Resultative Constructions, while (46) is responsible for Ditransitive Construction.

(46)	$D:$	$X$	$V$	$\cdot$	$Z$
	$E:$	$X$	$W$	$Y$	$Z$
		$\Downarrow$	$\Downarrow$	$\Downarrow$	$\Downarrow$
	$F:$	$X$	$V$	$Y$	$Z$

I want to note here that it is probably an overgeneralization to conflate (46) into (45), or alternatively conflate (45) into (46), the latter of which is what Goldberg does. She does so by cunningly relaxing the specification for  $Z$ : it may be either PP (in Caused Motion and Resultative) or PP (in Ditransitive). But I find her generalization spurious, because the more exact form of (46) is the following, where  $p$  is a “missing” preposition which contrasts with *with* in *Joe provided Bill (with) the information*, and  $Z$  is

no longer the same as Goldberg's scheme in that it is exclusively NP.

(47)	<i>D:</i>	<i>X</i>	<i>V</i>	•	•	<i>Z</i>
	<i>E:</i>	<i>X</i>	<i>W</i>	<i>Y</i>	<i>p</i>	<i>Z</i>
	↓	↓	↓	↓	↓	
	<i>F:</i>	<i>X</i>	<i>V</i>	<i>Y</i>	<i>p</i>	<i>Z</i>

Putting aside the overtness of *p* in *E* (and *F*), there is an overlooked difference between (45) and (47). It is the position of the unit in *D*, which is shared with *E* (and is to be apparently “right-node raised”). While *Y*, if present, is the shared unit in (45), *Z* is the shared unit in (47).

Is *Z* obligatorily present in (47)*D*? No, not at all. Consider the following possibility of blending, though, as far as I can see, Goldberg's account misses it.

(48)	<i>D:</i>	<i>X</i>	<i>V</i>	<i>Y</i>	•	•
	<i>E:</i>	<i>X</i>	<i>W</i>	<i>Y</i>	<i>p</i>	<i>Z</i>
	↓	↓	↓	↓	↓	↓
	<i>F:</i>	<i>X</i>	<i>V</i>	<i>Y</i>	<i>p</i>	<i>Z</i>

This pattern is responsible for the following expressions, I guess.

- (49)
- a. Joe calls his bicycle *Rolling Thunder II*.
  - b. We name the ship *Queen Elizabeth*.
  - c. Jim regards his way of thinking (to be) out of fashion.

This is a point that Goldberg's account misses, if not dismisses.

#### 4.6 Reinterpreting Goldberg's account in terms of pattern blending

Putting aside those problems of how patterns are “represented” (in mind and grammar), let us now concentrate on the exploration into construction effect. Given (45) and (46) as general schemes for pattern blending, we can claim that Goldberg's argument structure construction is reinterpreted in a straightforward way. Goldberg's Caused Motion Construction and Resultative Construction are, respectively cases where *W* in (45)*E* is likened to verbs like *put*, *get*, one the one hand, and to verbs like *make* or *get*, on the other. Likewise, her Ditransitive Construction corresponds to the case where *W* in (46)*E* is likened to a class of verbs which are direct and indirect syntactic/semantic variants of *give*. To see this, let us consider again groups (50)–(52). As we have seen above, sentences in (50)–(52) are respective instantiations of ditransitive, caused motion, and resultative constructions in the sense of Goldberg (1995).

- (50)
- a. Joe kicked Bill the ball.
  - b. Pat faxed Bill the letter.
- (51)
- a. Pat sneezed the napkin off the table.
  - b. The sergeant waved the tank into the compound.
  - c. Joe kicked the ball to Bill.
  - d. Pat faxed the letter to Bill.
- (52)
- a. Bill hammered the metal flat.
  - b. Bill ate himself sick.

It is almost trivial to see that all sentences in (50)–(52) are blended patterns in the sense defined above.

##### 4.6.6 Blending analysis of Ditransitive Construction

Let us examine first the case of ditransitive construction, of which (50)a is an instance. This is a blend such as characterized in (53).

(53)	<i>D:</i>	Joe	kicked	•	•	the ball
	<i>E:</i>	Joe	<i>W</i>	Bill	∅	the ball
	⇓	⇓	⇓	⇓	⇓	⇓
	<i>F:</i>	Joe	kicked	Bill	∅	the ball

where patterns *D* and *E* are blended into *F* (by unification with permission of overriding *kicked* over *W*).

But the status of *E* is somewhat unclear, especially regarding *W*. My best guess is that *W* may not be occupied by any overt verb. If so, it will be inadequate to write, for *E*, *Joe send Bill the ball*, or *Joe gave Bill the ball*, which I reserve myself from doing so. This is because, in my opinion, *E* is best understood as a **schematized context** of *W*, which emerges as mental operation of abstraction applies to syntactic contexts for special verbs such as *give*, *get*, *make*, and their syntactic/semantic derivatives such as *send* (< *give*). To put it somewhat differently, construction effect is such that particular contexts of lexical units, such as *Ann* — *Bill the letter* (or possibly — *Bill the letter*), *Ann* — *the letter to Bill* (or also possibly — *the letter to Bill*) “induce” the special verbs to fill it.

It should be remarked that the our view of construction effect is virtually the same as identification of “prototypical” or “typical” contexts relative to certain verbs. I am aware that the notion that I advocate here is different from usual prototypes. In most discussions of prototype theory, prototypicality is deemed as a property of items. But I advocate the notion of prototypicality of “configurations”. This is undoubtedly a controversial view, but this view, in a sense, embodies a highly “interactionist” and “emergentist” view of meaning in that it assumes a highly “associative” theory of memory, which is motivated by “connectionist” theorizing.<sup>14</sup> Since this is an issue hard to discuss concisely, I will return to it in Concluding Remarks.

Putting aside technical issues, let us compare immediately our analysis given in (53) with Goldberg’s composition illustrated in Figure 8.1, repeated here for convenience.

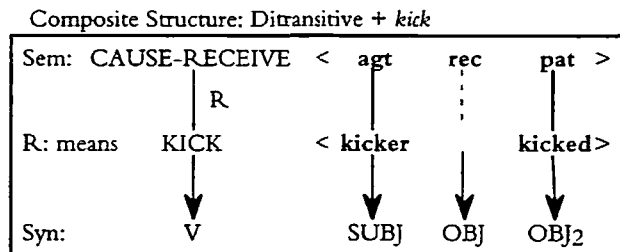

Figure 8.1 [cf. Goldberg’s Figure 2.9, 1995, p. 54]

Ignoring irrelevant details, we may say: (i) the specification CAUSE-RECEIVE<agt, rec, pat> in the first row, Sem, corresponds to that of (53)*E*; (ii) KICK<kicker, —, kicked> in the second row, R: means, corresponds to that of (53)*D*; and (iii) the result of semantic composition in the third row, Syn, corresponds to that of (53)*F*. Despite this obvious compatibility, there is still a crucial conceptual difference. Goldberg’s construction account is primarily responsible for the semantics of sentences, where surface syntax is of secondary importance (to witness, *V* is the leftmost in all component structures), whereas our account is responsible for both syntactic and semantics. This makes a great difference.

The last point suggests that pattern blending analysis is superior to Goldberg’s not only because it is capable of taking care of the semantics as successfully as Goldberg’s construction grammar account, but also because it is capable of taking care of the syntax as well. On these grounds, we may claim, I believe, that pattern blending account is more elegant and even more natural than Goldberg’s, though the notion “natural” may depend crucially on one’s previously formed system of assumptions. It is unfortunately possible that my account looks like less natural than Goldberg’s since it smells

14. Bates and Elman (1993) is a best introduction to connectionism: it is concise, precise, and witty, but very informative. For more technical aspects, see Rumelhart, *et al.* (1986), McClelland, *et al.* (1986). For fuller, but less technical, details, see Bechtel and Abrahamsen (1990), Elman, *et al.* (1996).

“transformationalist” to some of cognitive linguists who tend to think that devices necessary for meaning construction are given as they are, and who do never ask for the reason of their existence. I have nothing more to say to them.

#### 4.6.6 Blending analysis of Caused Motion Construction

Now, let us turn to the case of caused motion construction. We can provide analyses as follows.

(54)	<i>D</i> :	Joe	kicked	the ball	•	•
	<i>E</i> :	Joe	$W_1$	the ball	to	Bill
		⇓	⇓	⇓	⇓	⇓
	<i>F</i> :	Joe	kicked	the ball	to	Bill
(55)	<i>D</i> :	Pat	sneezed	•	•	•
	<i>E</i> :	Pat	$W_{II}$	the napkin	off	the table
		⇓	⇓	⇓	⇓	⇓
	<i>F</i> :	Pat	sneezed	the napkin	off	the table

As illustrated, there are two major subclasses of this construction, depending on whether *V* in *D* is transitive or intransitive verb (or equivalently *Y* is present or not). But this is not all of their differences; their syntactic/semantic models are different, too.  $W_1$  is most likely to be tailored to *send* (and indirectly to *give*), whereas  $W_{II}$  is likened to *put*, *get*, never *send*. Of course, it is hardly possible to determine which verb of this class is the exact model of *E*. In my view, we may give up the idea altogether that *W* must be determined, especially relying on the notion of “undespecification”. *W* is merely a union of all of such verbs.

#### 4.6.6 A note on the relation of Caused Motion Construction

Goldberg’s caused motion construction is an undergeneralization of the relevant facts. Note that the following patterns, which meet formal criterion  $F = X \ V \ Y \ (P) \ Z$ , as well as caused motion construction, exhibit the opposite sort of construction effect, at least originally.

- (56) a. She *waked* her husband with her kick.  
 b. He *revived* the sleeping beauty with his kiss.

Admittedly, the semantic contribution of *with Z* in these examples is more subtle than other cases, but it is still likely that even these patterns are blends of  $D = X \ wake \ Y$  and  $D' = X \ revived \ Y$  with (57)*E* and *E'*, respectively.

- (57) *E*:  $X \ provide \ Y \ with \ Z$   
*E'*:  $X \ supply \ Y \ with \ Z$

Interestingly, also in this class, abstract motion (of *Y*) is “caused” by an act of *X*, but not in the way that Caused Motion Construction specifies. Despite the formal similarity to Caused Motion Construction, patterns of this class behave more like Ditransitive, since causation is conceived of as a sort of “gift”, or “supply” of cause/energy. But this fact is puzzling as far as English lacks  $X \ give \ Y \ with \ Z$ , at least overtly. I suspect that this argues for the existence of missing *p* in (47), which may realize as with in other contexts like (57)*E* and *E'*.

Another possibility is that patterns like (57)*E* and *E'* are semantically tailored to more basic pattern  $X \ given \ Y \ Z$ , which accidentally misses preposition before *Z*.

#### 4.6.6 Blending analysis of Resultative Construction

Let us turn to resultative construction. The construction can be analyzed in the following way. Like in caused motion construction, *V* is either transitive or intransitive.

(58)	<i>D:</i>	Bill	hammered	the metal	•
	<i>E:</i>	Bill	<i>W</i>	the metal	flat
	⇓	⇓	⇓	⇓	⇓
	<i>F:</i>	Bill	hammered	the metal	flat
(59)	<i>D:</i>	Bill	ate	•	•
	<i>E:</i>	Bill	<i>W</i>	himself	sick
	⇓	⇓	⇓	⇓	⇓
	<i>F:</i>	Bill	ate	himself	sick

I guess that *W* is similar to *get*, or *made*, since *E* is probably the (parsimoniously determined) union of their syntactic contexts.

#### 4.7 Constructional meanings are meanings of syntactic contexts

Discussions so far are substantial enough to prepare for a reinterpretation of Goldberg's work on derived argument structures. Let me summarize as briefly as possible.

I am willing to hold that Goldberg's account is more appealing than accounts based on lexical semantics of verbs. But I want to claim that it is still less appealing than pattern blending account that I have provided in his paper. Let me specify a few reasons.

The notion of constructions, defined as "form/meaning pairs", is in need for solving the problem of "emergent" senses. As Goldberg correctly points out, if the meaning of *Pat faxed Bill the letter* [= (50)b], for example, is determined exclusively by meanings of lexical items that compose it, then it follows that there is at least one lexical item that is responsible for the emergent sense of "benefaction" observable in the sentence. It is usual that, based on the logic of exclusion, the sense in question is usually attributed to the "lexical meaning" of main verbs, e.g., *fax* in (50)b, which, Goldberg claims, is implausible.

There are gaps to be filled in this argument. Indeed, whether this account is or is not implausible crucially depends on the assumed mechanism of meaning construction. Even if there is emergent meaning (e.g., of benefaction) in sentences like (50)b, this by no means implies that there must exist one and only one lexical item that is exclusively responsible for the emergent sense in question. The emergent sense need not be attributed to none of lexical items, especially verbs. This is what Goldberg argues for in terms of constructions, which exist in the grammar of English, independently of lexical meanings. But Goldberg's account seems to me an understatement, and there is another direction to pursue. It is possible not to attribute the emergence of constructional meanings to constructions *per se*, but to the interaction of the component meanings of lexical items (except verb). This is what I suggested above: if the interaction of lexical items is so effective that certain "missing" verb are recalled, by context induction, to fit into syntactic contexts like *Ann \_\_\_ Bill the letter*, it is harder to simply assert that there are such and such constructions. This is to say that the emergent senses may be an emergent property of a specific kind of formation, not of any forms. Some of the formations seem to be so much "conventionalized" to be used very productively.<sup>15</sup>

To my best knowledge, construction effects, if anything, are the other side of lexical meaning. Constructional and lexical meanings are probably the yin and yang of verb senses. If verb senses are positives, constructional meanings are negatives of them. Or more explicitly, constructions are abstracted contexts into which some special, frequently used, basic-level verbs such as *give*, *get*, *make* are used. They are implicit, "ghost" verbs in such abstract units. Ditransitive construction, for example, can be reinterpreted context schema made available for other verbs, which we may denote by *X \_ Y Z / \_ V \_*. This schemas is abstracted out of an large number of instances of *X give Y Z*. In this sense, they are also emergent forms out of the complex interaction between surface forms (with implicit meanings).

#### 4.8 Where does polysemy come from? (or, Why so many constructions?)

15. This intends that the problem of productivity is a matter different from emergence.

Pattern blending analysis not only provides a sophisticated analysis of construction effect, but also provides a natural solution to the problem of “polysemy”, at whose solution Goldberg’s account is usually deemed to be most successful. Let us discuss this issue in some detail.

Goldberg states (p. 75) that  $F = X V Y Z$  (where  $Z$  is NP) instantiates ditransitive construction if  $F$ , as a whole, is associated to the class of interpretations specified below (see also Figure 2.2 p. 38), where I removed small capitalization.

- (60)
1. “ $X$  causes  $Y$  to receive  $Z$ ” (central sense; e.g., *Joe gave Sally the ball*)
  2. Conditions of satisfaction imply “ $X$  CAUSES  $Y$  TO RECEIVE  $Z$ ” (e.g., *Joe promised Bob a car*)
  3. “ $X$  enables  $Y$  to receive  $Z$ ” (e.g., *Joe permitted Chris an apple*)
  4. “ $X$  causes  $Y$  not to receive  $Z$ ” (e.g., *Joe refused Bob a cookie*)
  5. “ $X$  intends to cause  $Y$  to receive  $Z$ ” (e.g., *Joe baked Bob a cake*)
  6. “ $X$  acts to cause  $Y$  to receive  $Z$  at some future point in time” (e.g., *Joe bequeathed Bob a fortune*)

Furthermore, Goldberg states (p. 76) that  $F = X V Y Z$  (where  $Z$  is directional PP) instantiates caused motion construction if  $F$ , as a whole, is associated to the class of interpretations specified below (see also pp. 161-162).

- (61)
1. “ $X$  causes  $Y$  to move  $Z$ ” (e.g., *Pat pushed the piano into the room*)
  2. Conditions of satisfaction imply “ $X$  causes  $Y$  to move  $Z$ ” (e.g., *Pat ordered him into the room*)
  3. “ $X$  enables  $Y$  to move  $Z$ ” (e.g., *Pat allowed Chris into the room*)
  4. “ $X$  causes  $Y$  not to move from  $Z$ ” (e.g., *Pat locked Chris into the room*)
  5. “ $X$  helps  $Y$  to move  $Z$ ” (e.g., *Pat assisted Chris into the room*)

The problem of polysemy is real, and really complex, but I suspect it is not so complex as Goldberg argues. In my view, her account uselessly complicates the problem which is less complex, if my contention is true that pattern blending serves as a simpler and superior mechanism, not necessarily generative, to account for such proliferation of senses. To substantiate this claim, let us look more closely at the problem by analyzing some examples.

Take for example  $F = \textit{Joe promised Bob a car}$ , an instance of Goldberg’s (60)2. If our blending analysis is correct,  $F$  is a blend of  $D$  and  $E$ , such as specified below.

- (62)
- |       |     |          |     |   |     |
|-------|-----|----------|-----|---|-----|
| $D$ : | Joe | promised | •   | a | car |
| $E$ : | Joe | $W$      | Bob | a | car |
|       | ⇓   | ⇓        | ⇓   | ⇓ | ⇓   |
| $F$ : | Joe | promised | Bob | a | car |

We may reasonably assume that  $F$  inherits the semantics of  $D$ , as well as that of  $E$ .

$W$  in  $E$  can be approximated by an appropriate verb (e.g., *give*), assuming a mechanism for the semantic approximation of  $W$ , which I presume is essentially pragmatic and associative. Note, however, that the assumed mechanism of  $W$ -approximation cannot be economically accounted for by the notion of construction. In construction grammar accounts like Goldberg’s, a decision must be arbitrarily made as to how many constructions are posited, since there is no limit on it.

In pattern blending account, however, *give* is merely a typical, or rather a “fail-safe” approximation of  $W$ . Indeed,  $W$  may be more specific, depending on assumptions usually formed conversationally. Consider the following case.

- (63) In his last will, *Joe promised Bob his Rolls Royce* (but, he was mistaken; it was sold to someone long before).

If  $W$  exists in this example, it should be *bequeath* rather than *give*. Of course, this does not mean that  $W$  may not be *give*: the alleged inappropriateness of *give* for  $W$  here is probably due to the fact that it is an “understatement”, since more information is inferable even from this short context. But such



complication happens merely because the act of bequeathing is a special case of promising.

There is nothing complicated in the semantics of *F*, as far as *F* is regarded as a blend, or a special case of composition of *D* and *E*. Specifically, the special sense that Goldberg attributed to (60)2 is a simple consequence of a simple fact: the semantics of *F* is composition of those of *D* and *E*. So, it is redundant to specify, like Goldberg does, that there is a specialized construction which assigns to  $F = X \vee Y Z$  meaning *M* such as in (60)2, because, if pattern blending is assumed, additional sense 'Conditions of satisfaction imply ...' is inherited from *D* which consists of a verb, *promise*, whose semantics is responsible for the added sense, if it is not inherited from *E*. I suspect that Goldberg is mistakenly trying to account for conditions by their effects.

Admittedly, whether such senses are conditions or effects of pattern blending is itself debatable. To be fair, I admit that it is needed to specify certain independently motivated conditions for pattern blending. I am willing to admit that the way to specify them is implicitly incorporated in Goldberg's work. Crucial mechanism must be "chained" relaxation of selectional restrictions for *W* to yield "radial" structure in the sense of Lakoff (1987). Abstractly, the story goes like this. Given blending of  $D = X \text{ promise } Z$  and  $E = X \text{ } W \text{ } Y \text{ } Z$  (where *W* is semantically approximated by *give*<sub>0</sub>) is sanctioned. This internally prepares a chain of relaxations one of which is blending of  $D' = X \text{ bequeath } Z$  and *E*. The basic mechanism of this is a variety sorts of "inheritance" in the sense of Goldberg, one of which is such a relation that  $D'$  is a special case of *D*. Grammar in action is full of such preparations. Metaphorically, these preparations are guns loaded with bullets. Those guns may not or need not fire, since discharge of such potential is highly contingent: there are a number of "blocking" factors to prevent actual firings. Admittedly, preparation of potentials is not a sufficient condition, or even not a necessary condition, but this does not really matters, I believe, because it works as a rough characterization of the basic mechanism. More than this is a tall story.

We are talking now about the "extension" of existing constructions, and self-changing of grammar. This process could be best understood in terms of "self-organization" of grammar, which I contend is a "chaotic" process that highly complex interactions of "internal" and "external" conditions bring about. With the distinction of the two kinds of conditions, what I have sketched above, together with Goldberg at least in spirit, is at best sketch out a hypothesis about the relevant internal conditions. Plainly, external conditions are out of scope, since I am rather skeptical that they can be usefully specified and exploited in linguistic explanation, at least without quantitative basis. For this specific reason, I am satisfied that conditions for pattern blending cannot be explained away.

But, if the internal conditions are the same as what Goldberg specifies in (60), and (61), under polysemous senses of *F*, circularity is sure to begin. In (60) and (61), conditions are stated in terms of effects. By doing this, Goldberg is caught in the same kind of trap that generative grammarians are in, who claim, quite fallaciously, that grammatical rules "account for" grammatical phenomena that are "described by" them. This manifests "first order isomorphism fallacy" in the sense of Kugler, *et al.* (1982).

To add evidence, let us take for example *Pat locked Chris into the room*. Blending analysis of this expression is either (64) or (65) below, depending on whether *lock* semantically selects as primary object *Chris* (affected object) or *the room* (location).

(64)	D:	Pat	locked	Chris	•	•
	E:	Pat	<i>W</i>	Chris	into	the room
	↓	↓	↓	↓	↓	↓
	F:	Pat	locked	Chris	into	the room
(65)	D:	Pat	locked	•	•	the room
	E:	Pat	<i>W</i>	Chris	into	the room
	↓	↓	↓	↓	↓	↓
	F:	Pat	locked	Chris	into	the room

My best guess is that *W* is approximated by *put*, especially when motional preposition *into* is present. Pragmatics should play a crucial role here again. Note that the induced sense of *put* is not simple; it is better approximated by *put back*, since it is "reagentive" against *Chris's* effort to go out the room.

Again, the elaborated sense "X causes Y not to move from Z" partly comes from the semantics

of *lock*. From the statement "Pat locked Bob", for example, one can easily infer that "Pat made Bob stay somewhere". The implied place can be denoted by *in the room*. This reveals that what gives constructional effect to this example is the use of *into the room* instead of *in the room*. Consider the following case, where *into* is replaced by stative prepositions *in* or *inside*. We may reasonably assume that (66)a is the blend of b and c (or c'), whether c or c' is irrelevant here.

- (66) a. Pat *locked* Chris *in(side)* the room.  
 b. Pat *W* Chris *in(side)* the room.  
 c. Pat *locked* Chris.  
 c'. Pat *locked* the room.

In this case, *W* could be best approximated by *keep*: *W = put* is an understatement in this case, since "put *Y* *in(side)* *Z*" does not entail "keep *Y* *in(side)* *Z*". On this ground, I claim that there is nothing mysterious in  $F = \text{Pat locked Chris into the room}$  if it is recognized that  $F$  is a pragmatically augmented version of  $F' = \text{Pat locked Chris in(side) the room}$  in that the sense of potential verb *keep* in  $F'$  undergoes accommodation based on such inference that "X's putting *Y* back into *Z*" (where  $Z = \text{the room}$ ) is a special case of "X's keeping *Y* *in(side)* *Z*" as far as there is "Y's attempt to go out *Z*". We may be sure that humans can reason quite "heuristically" like this.

Discussions so far suggest that pattern blending provides a better account of the "network" of polysemy, of ditransitive construction in (60), and of caused motion construction in (61), which Goldberg takes great pains to enumerate one by one. On our view, polysemous senses in question are fairly straightforward "side-effects" of pattern blending. To put more adequately, this is because the semantics of  $F$ , a blend of  $D$  and  $E$ , is semantic composition of what are meant by  $D = X V (Y)$  (or  $X V Z$ ) and  $E = X W Y (P) Z$  on their own grounds. In my view, Goldberg is right in emphasizing the role of  $E$ , from which constructional meanings are partly derived, but she is nevertheless wrong in overestimating the role of  $E$ , and underestimating the role of  $D$ .

What is at issue is the problem of compositionality, especially the nature of it, I suspect. Goldberg indeed takes great pains to convince us that constructional meanings assigned to  $F = X V Y Z$  are not, and even cannot be, specified compositionally. But her effort seems to me pointless and unrewarding, partly because whether meaning construction is compositional or not is itself a matter of definition, and partly because this effort itself deprives her account of explanatory power. It is clear that she mistakes effects for conditions of them. By this misconception, she is forced to preposterously claim that what are "described by" constructions are "accounted for" by them.

## 5 Concluding Remarks

I showed in this paper that Goldberg's construction grammar account of argument structure phenomena can be enriched under reinterpretation that I proposed. But I know my own work owes greatly to her work, so I am somewhat afraid that I might have misrepresented her account and approach. I want to add a few remarks that will remedy them, if any.

### 5.1 What are "accounted for" in Goldberg's account?

It may be argued that the view that I advocate here is, in the end, equivalent to construction accounts like Goldberg's. This is not really the case, I believe. In construction accounts, the existence of constructions is the reason for the emergent meanings of sentences; in other words, it predicts, fallaciously I think, that the sense of, say, benefaction can emerge as far as ditransitive construction exists. But it is clear that this account obscures the very reason why such constructions can ever exist in a grammar. At worst, constructions are merely stipulated for explanation of relevant facts, and justified by (usually partial) success of intended explanation. In this regard, the status of constructions is not so different from that of generative rules (e.g., linking rules, lexical redundancy rules), which constructions are intended to replace. At worst, this is merely a translation of one mystery into another, though the degree of implausibility decreases a little. In interactionist view, constructions are no more reasons than generative rules are: they are merely effects of ill known causes that lead, in combination, to a variety of emergent properties one of which is the existence of so-called constructional meanings, not necessarily of constructions *per se*.

It is likely that the essence of Goldberg's claim is that even abstract forms such as  $F = S V O_1 (P) O_2$  are "gestalts" in that they have meanings of their own, which cannot be reduced to the meanings of their parts. This forms a basic claim of cognitive linguistics against formalist linguistics which holds strict compositionality. If strict compositionality is assumed, then it makes no sense to claim that  $F$  has meaning irreducible to the meanings of its parts.

Goldberg starts her argument by noting that sentences of the form have specifiable range of meanings which are not predictable from the lexical meanings of their components, but become predictable if forms themselves have meanings of their own. But her argument is false, at least literally. Construction meanings, if they are real, are still meanings that are determined by their component meanings, though interactively, because, if my analysis is correct, the inherently under-specified meaning of  $W$  becomes identifiable, or at least so significantly narrowed to be identifiable, only with the semantic construction of  $X$ ,  $Y$ , and  $(P) Z$ .

Goldberg's is still right, I want to hold, in arguing that argument structure is an "emergent" property, and I am willing to agree with her on this point. So, what really matters is not whether constructional meaning is or is not reducible to lexical meanings, or even whether it is reducible to the meaning of main verbs; but what really matters is the way that meaning construction is "compositional", or the way the meanings of parts contribute to the meaning of the whole.

## 5.2 Toward a new conception of "compositionality"

The cognitivist ban on the compositionality in favor of gestalt-like property is a bad idea, I suspect. Compositionality is preserved, or rather it is "overly" preserved. Note that construction effect is better characterized by the "excess" of meaning composition rather than the "lack" of it; for, in my view, constructional meaning of  $F = X V Y P Z$  emerges when "background" patterns like  $D = X V Y$  and  $E = X \_ Y P Z$ , among others, are interpreted. Why is there such apparently "superfluous", if not unnecessary, construction of meaning? In my view, what is really at issue is the notion of "proper analysis", accordingly to which analysis of patterns may not be overlapping and tangling.

But there is another point of view that seems fully compatible with the puzzling fact: it is to view grammar as a "performance system", where robustness and conciseness need be well balanced. It is easy to note that, generally, simpler systems are faster but more fragile. Redundancy is a virtue to lead to robustness of a system. If robustness is taken into account, it is less mysterious if meaning construction relies on crucial use of overlapping.

Perhaps, we have been misguided for a long time by a "bad" picture of meaning construction, which I claim fails to draw essential properties of meaning construction. In this picture, structure of a sentence is a "tree" with many branches (though this tree grows downward), whose leaves are (possibly null) lexical items. Meaning of this sentence is so constructed that meanings of the lexical items are "composed" as they "climb up" the tree.

If this popular picture depicts the reality correctly, there should be no chance for background patterns like  $X \_ Y P Z$  to be associated to some meaning. But it is sure that this is a bad picture that distorts much of reality, and we may reject it all together with those "connectionists", or cognitive scientists working in the framework of "parallel distributed processing" (PDP). It is remarked that in connectionist conception, it is more likely that proper analysis is not guaranteed. Processes in connectionist networks are massively parallel to be capable of successfully handle such notorious problems of overlapping and discontinuous constituents. To illustrate, I present below a diagram which illustrates required handling of discontinuity and overlapping in meaning construction of  $F = \text{Joe faxed Bill the memo}$ , where lexical units, namely  $X = \text{Joe}$ ,  $V = \text{fax}$ ,  $Y = \text{Bill}$ ,  $P = \emptyset$ , and  $Z = \text{the memo}$ , are arranged at the bottom, and the result of composition,  $F$ , is at the top. Between them are "incomplete" composite units like  $A = \text{Joe kicked } O$ ,  $B = \text{S faxed the memo}$ , and  $C = \text{S } W \text{ Bill } \emptyset \text{ the memo}$  (where  $S$  is for subject,  $O$  for object, and  $W$  for implicit verb) are arranged.

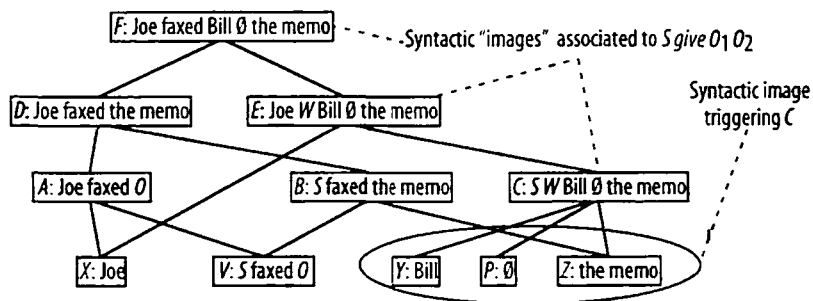

Figure 8.8

This diagram no longer illustrates a constituent structure. Not only discontinuous constituents are permitted (e.g.,  $B = \text{Joe faxed the memo}$ ), but multiplicity of constituents is permitted so that some units, *Joe* and *the memo*, are composed twice. My reason for preferring diagrams like this is deeper, however. I hold that this unusual sort of diagrams indeed characterize more adequately the overall computation responsible for pattern blending of  $F$ , though I unfortunately can offer, in this paper, no detailed arguments or pieces of evidence. But I have good evidence, as well as reason, to believe that so-called “phrase structures” or “constituent structure” are poor devices to represent syntactic structure of sentences. I will discuss this point in enough detail in my Ph.D. dissertation (Kuroda in preparation). In this work, I will argue more thoroughly that syntactic structures, if any, are not trees but “webs” of connections among words through which words communicate with each other. Under this provisional note, I claim that pattern matching analysis is coming to provide you with a new view of meaning construction based on a new conception of syntactic structures.

## References

- Bates, Elizabeth A., and Jeffrey L. Elman.  
 1993 Connectionism and the study of change. In *Brain Development and Cognition: A Reader*, edited by Mark H. Johnson. Oxford, UK: Basil Blackwell.
- Bechtel, William and Adele Abrahamsen  
 1990 *Connectionism and the Mind: An Introduction to Parallel Processing in Networks*. Oxford: Blackwell.
- Bolinger, Dwight L.  
 1961 Syntactic blends and other matters. *Language*, 37: 366-381.  
 1967 Apparent constituents in surface structure. *Word*, 23: 47-56.  
 1977 *Meaning and Form*. London: Longman.
- Elman, Jeffrey L., Elizabeth A. Bates, Mark H. Johnson, Annette Karmiloff-Smith, Domenico Parisi, and Kim Plunkett  
 1996 *Rethinking Innateness: A Connectionist Perspective on Development*. Cambridge: MIT Press.
- Fauconnier, Gilles R.  
 1994 *Mental Spaces: Aspects of Meaning Construction in Natural Language*. Cambridge University Press.  
 1997 *Mappings in Thought and Language*. Cambridge, UK/New York, NY: Cambridge University Press.
- Fillmore, Charles J., Paul Kay, and Catherine O'Connor  
 1988 Regularity and idiomatity in grammatical constructions: The case of *let alone*. *Language*, 64 (3): 501-538.
- Goldberg, Adele E.  
 1995 *Constructions: A Construction Grammar Approach to Argument Structure*. Chicago/London: University of Chicago Press.
- Goldsmith, John  
 1979 *Autosegmental Phonology*. New York: Garland Press.  
 1990 *Autosegmental and Metrical Phonology*.
- Goldsmith, John, ed.  
 1993 *The Last Phonological Rule: Reflections on Constraints and Derivations*. Chicago: University of Chicago Press.
- Grimshaw, Jane

- 1990 *Argument Structure*. Cambridge, MA: MIT Press.
- Harris, Randy Allen  
1993 *The Linguistics Wars*. New York: Oxford University Press.
- Kay, Paul  
1997 *Words and the Grammar of Context*. Stanford, CA: CSLI Publications.
- Karttunen, Lauri  
1993 Finite-state constraints. In Goldsmith, *ed.* (1993, pp. 173-94).
- Kugler, P., M. Turvey, and R. Shaw  
1982 Is the cognitive penetrability criterion invalidated by contemporary physics? *Behavioral Brain Science*, 5, 303-306.
- Kuroda, Kow  
1996 Pattern matching analysis: Toward cognitive syntax. In *Papers in Linguistic Science*, 2, pp. 87-117. Kyoto: Kyoto University.  
in prep Foundations of Pattern Matching Analysis. Ph.D. dissertation. Kyoto: Kyoto University.
- Lakoff, George  
1970 *Irregularity in Syntax*. New York: Holt, Rinehart & Winston. [Publication of the author's Ph. D. dissertation submitted to Indiana University]  
1987 *Women, Fire, and Dangerous Things: What Categories Reveal about the Mind*. Chicago: University of Chicago Press.  
1990 The Invariance hypothesis: Is abstract reason based on image-schemas? *Cognitive Linguistics*, 1 (1): 39-74.  
1993 Cognitive phonology. In J. Goldsmith, *ed.* (1993, pp.117-145 ).
- Langacker, Ronald W.  
1987 *Foundations of Cognitive Grammar, Vol. 1: Theoretical Prerequisites*. Stanford, CA: Stanford University Press.  
1991a *Concept, Image, and Symbol: The Basis of Cognitive Grammar*. Berlin/Mouton de Gruyter.  
1991b *Foundations of Cognitive Grammar, Vol. 2*. Stanford, CA: Stanford University Press.
- McCarthy, John  
1981 A prosodic theory of nonconcatenative morphology. *Linguistic Inquiry*, 12 (373-418).
- McCawley, James D.  
1988 *The Syntactic Phenomena of English, Vols. I and II*. Chicago/London: University of Chicago Press.
- McClelland, James L., David E. Rumelhart, and The PDP Research Group  
1986 *Parallel Distributed Processing—Explorations in the Microstructure of Cognition, Vol. 2: Psychological and Biological Models*. Cambridge, MA: MIT Press.
- Rumelhart, David E., James L. McClelland, and The PDP Research Group  
1986 *Parallel Distributed Processing — Explorations in the Microstructure of Cognition, Vol. 1: Foundations*. Cambridge, MA: MIT Press.