

Title	Electric Resistance of Magnetic Domain Wall in NiFe Wires with CoSm Pinning Pads (SOLID STATE CHEMISTRY-Artificial Lattice Alloys)
Author(s)	Nagahama, Taro; Mibu, Ko; Shinjo, Teruya
Citation	ICR annual report (2000), 6: 16-17
Issue Date	2000-03
URL	<a href="http://hdl.handle.net/2433/65241">http://hdl.handle.net/2433/65241</a>
Right	
Type	Article
Textversion	publisher

# Electric Resistance of Magnetic Domain Wall in NiFe Wires with CoSm Pinning Pads

Taro Nagahama, Ko Mibu and Teruya Shinjo

A NiFe wire of 1 $\mu$ m width with hard magnetic CoSm pinning pads and Cu electrodes was prepared by electron-beam lithography and lift-off technique. Using the exchange interaction between the NiFe wire and CoSm pads, magnetic structures with and without magnetic domain walls were realized at zero external field. The electric resistance of the wall state was smaller than that of the no-wall state. The difference of the resistance can be explained by the anisotropic magnetoresistance effect in the domain walls.

*keywords:* Submicron magnetic wire/ Exchange-spring bilayer/ Magnetic domain wall/ Hysteresis curve/ Anisotropic magnetoresistance

Recently electric transport properties through magnetic domain walls have been attracting much attention. Here we report an experiment using NiFe wires partially pinned by hard magnetic CoSm pads. The wire is magnetically composed of two parts; one is magnetically free areas that have a small coercive field and the other is pinned areas that have a large coercive field. In a weak magnetic field, only the magnetization in the free parts changes the direction, and therefore  $2N$  magnetic domain walls are nucleated at the boundary between two different areas (Here,  $N$  is the number of pinning pads). The resistance was compared for the no-wall state and  $2N$ -wall state at zero external field.

The sample was composed of a NiFe wire (thickness : 200 Å, width : 1  $\mu$ m, length : 300  $\mu$ m) and CoSm pinning pads. A schematic image of the sample is shown in Fig.1(a). Every part, i.e., a NiFe wire, CoSm pads, and Cu electrodes, was prepared by a lift-off technique. The deposition and lift-off processes were repeated three times to prepare the sample.

Figure 2 shows a minor hysteresis loop of the MR curve for a NiFe wire with three CoSm pinning pads. The starting point was the magnetically saturated state in a negative applied field (Fig.1(b)). When a magnetic field was applied to the opposite direction, the resistance decreased abruptly at a certain magnetic field ( $H_n$ ). Then,

## SOLID STATE CHEMISTRY — Artificial Lattice Alloys —

### Scope of research

*By using vacuum deposition method, artificial multilayers have been prepared by combining various metallic elements. The recent major subject is an interplay of magnetism and electric transport phenomena such as the giant magnetoresistance effect. Fundamental magnetic properties of metallic multilayers have been studied by various techniques including Mössbauer spectroscopy using Fe-57, Sn-119, Eu-151 and Au-197 as microprobes, and neutron diffraction. Microstructured films such as wires and dots were successfully prepared by electron-beam lithography and novel magnetic and transport properties are investigated.*



Prof  
SHINJO, Teruya  
(D Sc)



Assoc Prof  
HOSOITO, Nobuyoshi  
(D Sc)



Techn  
KUSUDA, Toshiyuki

**Guest Research Associate:**  
BACZEWSKI, L. Tomasz(D Sc)  
HASSDORF, Ralf (D Sc)  
**Students:**  
NAGAHAMA, Taro (DC)  
SHIGETO, Kunji (DC)  
ALMOKHTAR, A. M. M. (DC)  
FUJIMOTO, Tatsuya (MC)  
OKUNO, Takuya(MC)  
**Research Fellow:**  
HAMADA, Sunao

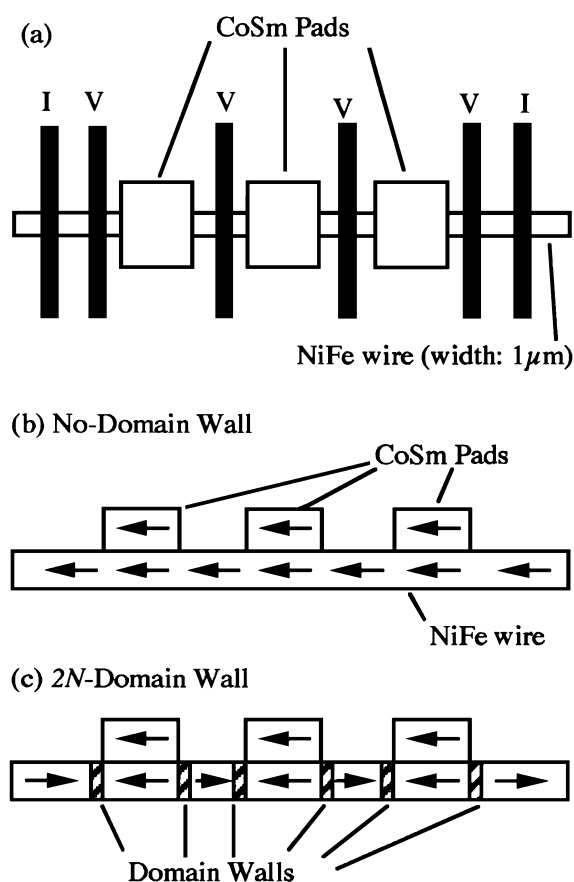

**Figure 1.** The schematic image of (a) a typical sample (top view), (b) no-wall state (magnetically saturated state)(side view), and (c)  $2N$ -wall state (side view).

the resistance slightly increased, and started to decrease again at  $H_b$ . When the magnetic field was decreased from 800 Oe, the resistance first changed almost reversibly down to  $H_n$ . The resistance decreased slightly until the magnetic field went across zero, and returned to the saturated value abruptly at  $H_r$ . This change in MR curve is understood as follows: At  $H_n$ , antiparallel magnetic domains were nucleated in the NiFe wire, with the magnetic domain walls situated at the boundary between the pinned area and the free area (Fig.1 (c)). When the magnetic field exceeded  $H_b$ , the magnetic moments of the NiFe layer in the pinned area started to rotate gradually like soft magnetic layers in exchange-spring bilayers [1]. When the magnetic field was reversed, the magnetization returned reversibly down to  $H_b$ . The magnetic domain walls remained down to  $H_r$ , and at  $H_r$  they were annihilated. The reason why the resistance decreases from  $H_b$  to  $H_r$  is not clear, but that can be concerned with the magnetic structure of domain walls

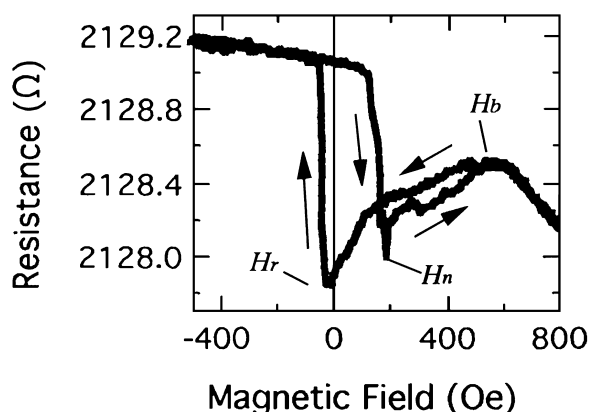

**Figure 2.** The minor loop of the magnetoresistance of a NiFe(200Å) wire with three CoSm(400Å) pads at 5 K.

that changes slightly in this field range. If the magnetic structure does not change, the resistance should be kept constant.

Obviously there is a difference of resistance ( $\Delta R$ ) between the  $2N$ -wall state and the no-wall state; the  $2N$ -wall state has a smaller resistance than the no-wall state. This result shows that the domain wall contributes to negative magnetoresistance. We calculated the length of the domain wall under the assumption that  $\Delta R$  is totally due to anisotropic magnetoresistance (AMR) originating from the magnetic moments that make certain angles with the electric current direction. For simplicity, the angle of the magnetic moment in the wall was assumed to change linearly. Then the length of the domain wall was estimated to be about 1  $\mu\text{m}$ . This value seems too long because usually the width of a domain wall is several hundreds Å. However, in a head-on-head wall in a nanowire, a longer and complex domain wall structure was observed by MFM measurement [2]. In this way, the observed decrease in magnetoresistance can be explained by the AMR effect in the domain walls.

## References

1. T.Nagahama, K.Mibu and T.Shinjo, J. Phys. D: Appl. Phys. 31(1998)43.
2. Y.Nozaki, K.Matsuyama, T.Ono and H.Miyajima, Jpn. J. Appl. Phys. 38(1999)6282.