

Title	Migration of Unstable Vacuum for Dissipative Systems (Development of Infinite-Dimensional Noncommutative Analysis)
Author(s)	Arimitsu, Toshihico
Citation	数理解析研究所講究録 (1999), 1099: 70-95
Issue Date	1999-06
URL	<a href="http://hdl.handle.net/2433/63042">http://hdl.handle.net/2433/63042</a>
Right	
Type	Departmental Bulletin Paper
Textversion	publisher

## Migration of Unstable Vacuum for Dissipative Systems

筑波大物理\* 有光敏彦 (Toshihico Arimitsu)

*arimitsu@cm.ph.tsukuba.ac.jp*

### I. INTRODUCTION

Quantum field theory is constructed upon a basic assumption of stability: the stabilities of vacuum and one-particle state. These stabilities are essential for perturbational calculations where physical particles are specified by asymptotic fields with renormalized masses. The vacuum, therefore the representation space, is specified by the annihilation and creation operators of the asymptotic field. For finite temperature, vacuum keeps its stability but one-particle state loses the stability because of thermal fluctuations. In this case, we do not have an asymptotic field. We cannot find it out by going back to infinite past nor going forward to infinite future. The concept of the *dynamical mapping* [1,2] was introduced to secure this situation, where the mapping of Heisenberg operators is not necessarily performed by means of asymptotic fields. In non-equilibrium and dissipative systems, the situation becomes much worse, where both vacuum and one-particle states are unstable. We do not know how one can extend the concept of the dynamical mapping to this challenging situation.

Within Thermo Field Dynamics (TFD) [1-4], two vacuums representing thermal equilibrium states of different temperatures are mutually unitary-inequivalent. We can calculate thermodynamic quantities by representing corresponding observable operators by means of the Fock space constructed on the thermal vacuum specified by temperature  $T$ . Therefore, it is interpreted that the quasi-static process induces a change of system among these unitary inequivalent representation spaces.

On the other hand, for realistic dynamical processes, how can we interpret this migration in the set consisting of the orthogonal (inequivalent) representation spaces? The situation may become more vivid when one remembers the process of the vacuum expansion in terms of thermodynamics. In this paper, by making use of Non-Equilibrium Thermo Field Dynamics (NETFD) [5-32], we will propose a possibility how one can deal

---

\*Institute of Physics, University of Tsukuba, Ibaraki 305-8571, Japan.

with the migration of a vacuum among the mutually inequivalent representation spaces. The time-evolution of a thermal vacuum (equivalently the time-evolution of a representation space) is controlled by dissipative thermal processes, and the dynamics of fields are specified by mechanical rules. The former may be described by a macroscopic time scale, whereas the latter by a microscopic one.

NETFD is a *canonical operator formalism* of quantum systems in far-from-equilibrium state which provides us with a unified formulation for dissipative systems (covering whole the aspects in non-equilibrium statistical mechanics, represented by the Boltzmann, the Fokker-Planck, the Langevin and the stochastic Liouville equations) by the method similar to the usual quantum field theory that accommodates the concept of the dual structure in the interpretation of nature, i.e. in terms of the *operator algebra* and the *representation space* (Fig. 1). The representation space of NETFD (named *thermal space*) is composed of the direct product of two Hilbert spaces, the one for *non-tilde* fields and the other for *tilde* fields.

The infinitesimal time-evolution generator (hat-Hamiltonian) of the quantum master equation within NETFD was discovered first [5,6] for the cases corresponding to stationary processes by, so to speak, a *principle of correspondence* which makes the connection between NETFD and the density operator formalism [33–35]. Then, it was found [7] that the time-evolution generator can be also derived upon several axioms such as (2) and (8) below. The renormalized time-evolution generator in the interaction representation (the semi-free hat-Hamiltonian) corresponding to non-stationary processes was derived together with an equation for the one-particle distribution function [8,9]. Within these aspects, the canonical formalism of dissipative quantum fields in NETFD was formulated, and the close structural resemblance between NETFD and usual quantum field theories was revealed [10,11]. The generating functional within NETFD was derived [12]. Furthermore, the kinetic equation was derived within NETFD [13], and the relation between NETFD and the closed time-path methods [36–38] was shown (see Appendix A for the relation of NETFD to the path integral method). The extension of NETFD to the hydrodynamical region, as well as the kinetic region, was started [14,15,39].

The framework of NETFD was extended further to take account of the quantum stochastic processes [16–21]. Here again NETFD allowed us to construct a unified canonical theory of quantum stochastic operators. The stochastic Liouville equations both of the Ito and of the Stratonovich types were introduced in the Schrödinger representa-

tion. Whereas, the Langevin equations both of the Ito and of the Stratonovich types were constructed as the Heisenberg equation of motion with the help of the time-evolution generator of corresponding stochastic Liouville equations. The Ito formula was generalized for quantum systems.

NETFD has been applied to various systems, e.g. the dynamical rearrangement of thermal vacuum in superconductor [23], spin relaxation [24], various transient phenomena in quantum optics [25–29], non-linear damped harmonic oscillator [30], the tracks in the cloud chamber (a non-demolition continuous measurement) [31], microscopic derivation of the quantum Kramers equation [32].

## II. FRAMEWORK OF NETFD

The dynamics of physical systems is described, within NETFD, by the Schrödinger equation for the thermal ket-vacuum  $|0(t)\rangle$ :

$$\frac{\partial}{\partial t}|0(t)\rangle = -i\hat{H}|0(t)\rangle. \quad (1)$$

The time-evolution generator  $\hat{H}$  is an tildian operator satisfying

$$(i\hat{H})^\sim = i\hat{H}. \quad (2)$$

The *tilde conjugation*  $\sim$  is defined by [3,4]:

$$(A_1 A_2)^\sim = \tilde{A}_1 \tilde{A}_2, \quad (3)$$

$$(c_1 A_1 + c_2 A_2)^\sim = c_1^* \tilde{A}_1 + c_2^* \tilde{A}_2, \quad (4)$$

$$(\tilde{A})^\sim = A, \quad (5)$$

$$(A^\dagger)^\sim = \tilde{A}^\dagger, \quad (6)$$

where  $c_1$  and  $c_2$  are  $c$ -numbers. The tilde and non-tilde operators at an equal time are mutually commutative:

$$[A, \tilde{B}] = 0. \quad (7)$$

The thermal bra-vacuum  $\langle 1|$  is the eigen-vector of the hat-Hamiltonian  $\hat{H}$  with zero eigen-value:

$$\langle 1 | \hat{H} = 0. \quad (8)$$

This guarantees the conservation of the inner product between the bra and ket vacuums in time:

$$\langle 1 | 0(t) \rangle = 1. \quad (9)$$

Let us assume that the thermal vacuums satisfy

$$\langle 1 | \sim = \langle 1 |, \quad |0(t_0)\rangle \sim = |0(t_0)\rangle, \quad (10)$$

at a certain time  $t = t_0$ . Then, (2) guarantees that they are satisfied for all the time:

$$\langle 1 | \sim = \langle 1 |, \quad |0(t)\rangle \sim = |0(t)\rangle. \quad (11)$$

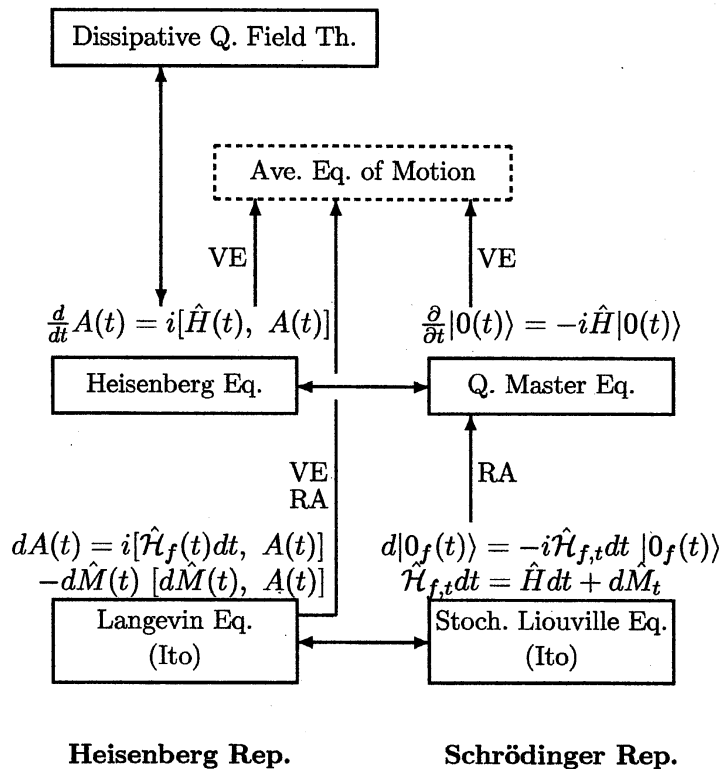

FIG. 1. System of the Stochastic Differential Equations within Non-Equilibrium Thermo Field Dynamics. RA stands for the random average. VE stands for the vacuum expectation.

The observable operator  $A$  should be an Hermitian operator consisting only of non-tilde operators. Its expectation value is real as can be proven as follows.

$$\begin{aligned}
 \langle A \rangle_t^* &= \langle A \rangle_t^\sim \\
 &= \{ \langle 1 | A | 0(t) \rangle \}^\sim \\
 &= \{ \langle 1 \rangle^\sim \tilde{A} \{ | 0(t) \rangle \}^\sim \\
 &= \langle 1 | \tilde{A} | 0(t) \rangle \\
 &= \langle 1 | A^\dagger | 0(t) \rangle \\
 &= \langle 1 | A | 0(t) \rangle \\
 &= \langle A \rangle_t.
 \end{aligned} \tag{12}$$

### An Example – Quantum Kramers Equation

Let us find out the general structure of hat-Hamiltonian which is bilinear in  $(x, p, \tilde{x}, \tilde{p})$ .  $x$  and  $p$  satisfies the canonical commutation relation

$$[x, p] = i. \tag{13}$$

Accordingly,  $\tilde{x}$  and  $\tilde{p}$  satisfies

$$[\tilde{x}, \tilde{p}] = -i. \tag{14}$$

The conditions,  $(i\hat{H})^\sim = i\hat{H}$ , and  $\langle 1 | \hat{H} = 0$  give us the general expression

$$\hat{H} = \hat{H}_0 + i\hat{\Pi}, \tag{15}$$

where

$$\hat{H}_0 = H_0 - \tilde{H}_0, \quad H_0 = \frac{1}{2m}p^2 + \frac{m\omega^2}{2}x^2, \tag{16}$$

$$\hat{\Pi} = \hat{\Pi}_R + \hat{\Pi}_D, \tag{17}$$

with

$$\begin{aligned}\hat{\Pi}_R &= -i\frac{1}{2}\kappa(x - \tilde{x})(p + \tilde{p}), \\ \hat{\Pi}_D &= -\frac{1}{2}\kappa m\omega(1 + 2\bar{n})(x - \tilde{x})^2.\end{aligned}\quad (18)$$

Here, we neglected the diffusion in  $x$ -space. The Schrödinger equation

$$\frac{\partial}{\partial t}|0(t)\rangle = -i\hat{H}|0(t)\rangle, \quad (19)$$

gives the *quantum Kramers equation*.

The Heisenberg equation for the dissipative system is given by

$$\begin{aligned}\frac{d}{dt}x(t) &= i[\hat{H}(t), x(t)] \\ &= \frac{1}{m}p(t) + \frac{1}{2}\kappa\{x(t) - \tilde{x}(t)\},\end{aligned}\quad (20)$$

$$\begin{aligned}\frac{d}{dt}p(t) &= i[\hat{H}(t), p(t)] \\ &= -m\omega^2x(t) - \frac{1}{2}\kappa\{p(t) + \tilde{p}(t)\} \\ &\quad + i\kappa m\omega(1 + 2\bar{n})\{x(t) - \tilde{x}(t)\}.\end{aligned}\quad (21)$$

Applying the bra-vacuum  $\langle 1|$  of the relevant system, we have the equations for the vectors:

$$\begin{aligned}\frac{d}{dt}\langle 1|x(t) &= \frac{1}{m}\langle 1|p(t), \\ \frac{d}{dt}\langle 1|p(t) &= -m\omega^2\langle 1|x(t) - \kappa\langle 1|p(t).\end{aligned}\quad (22)$$

The stochastic Liouville equation within the Ito calculus becomes

$$d|0_f(t)\rangle\rangle = -i\hat{\mathcal{H}}_{f,t}dt|0_f(t)\rangle\rangle, \quad (23)$$

with the stochastic hat-Hamiltonian

$$\hat{\mathcal{H}}_{f,t}dt = \hat{H}dt + d\hat{M}_t. \quad (24)$$

Here, the martingale operator  $d\hat{M}_t$  is defined by

$$d\hat{M}_t = \frac{\sqrt{\kappa m\omega}}{2}(x - \tilde{x})(dX_t + d\tilde{X}_t), \quad (25)$$

with

$$dX_t = dB_t + dB_t^\dagger, \quad (26)$$

where  $dB$ ,  $dB^\dagger$  and their tilde conjugates are the operators representing quantum Brownian motion (see Appendix B). The generalized fluctuation-dissipation theorem is given by

$$d\hat{M}_t d\hat{M}_t = -2\hat{I}_D dt. \quad (27)$$

Taking a random average, the stochastic Liouville equation (23) reduces to the quantum master equation (19) with

$$|0(t)\rangle = \langle |0_f(t)\rangle\rangle. \quad (28)$$

The stochastic Heisenberg equation (the Langevin equation) for this hat-Hamiltonian is given by

$$\begin{aligned} dx(t) &= i[\hat{\mathcal{H}}_f(t)dt, x(t)] - d\hat{M}(t) [d\hat{M}(t), x(t)] \\ &= \frac{1}{m}p(t)dt + \frac{1}{2}\kappa \{x(t) - \tilde{x}(t)\} dt, \end{aligned} \quad (29)$$

$$\begin{aligned} dp(t) &= -m\omega^2 x(t)dt - \frac{1}{2}\kappa \{p(t) + \tilde{p}(t)\} dt \\ &\quad - \frac{\sqrt{\kappa m \omega}}{2} \{dX(t) + d\tilde{X}(t)\}. \end{aligned} \quad (30)$$

The averaged equation of motion is given by

$$\frac{d}{dt} \langle\langle x(t) \rangle\rangle = \frac{1}{m} \langle\langle p(t) \rangle\rangle, \quad (31)$$

$$\frac{d}{dt} \langle\langle p(t) \rangle\rangle = -m\omega^2 \langle\langle x(t) \rangle\rangle - \kappa \langle\langle p(t) \rangle\rangle, \quad (32)$$

where  $\langle\langle \dots \rangle\rangle = \langle 1 | \langle | \dots | \rangle | 1 \rangle$ . The vacuums  $\langle |$  and  $| \rangle$  are introduced in Appendix B. These averaged equations can be also derived from (20) and (21) by taking the average  $\langle\langle \dots \rangle\rangle$ .

### III. STATIONARY STATE

Let us assume the existence of the eigen-equation

$$\hat{H}|0_E\rangle = \hat{E}|0_E\rangle, \quad (33)$$



where the eigen-value  $\hat{E}$  is a complex c-number called hat-energy.

Applying  $\langle 1|$  to (33) and making use of (8) and (9), we see that

$$0 = \langle 1|\hat{H}|0_E\rangle = \hat{E} \langle 1|0_E\rangle = \hat{E}. \quad (34)$$

Therefore, if there exists the eigen-vector satisfying (33), its eigen-value  $\hat{E}$  is equal to zero. The Schrödinger equation (1) tells us that the eigen-vector  $|0_E\rangle$  is a stationary state.

If we assume that there is only one equilibrium state, the stationary eigen-vector represents the thermal equilibrium state which will be referred to as  $|0_{eq}\rangle$ .

#### IV. VACUUM FOR CANONICAL ENSEMBLE (TFD)

Let us consider two sets of boson operators  $(a, a^\dagger)$  and  $(\tilde{a}, \tilde{a}^\dagger)$  which satisfy the commutation relation:

$$[a^\mu, \bar{a}^\nu] = \delta^{\mu,\nu}, \quad (35)$$

where we introduced the thermal doublet notation defined by

$$a^{\mu=1} = a, \quad a^{\mu=2} = \tilde{a}^\dagger, \quad (36)$$

$$\bar{a}^{\mu=1} = a^\dagger, \quad \bar{a}^{\mu=2} = -\tilde{a}, \quad (37)$$

and the Kronecker delta  $\delta^{\mu\nu}$ . These operators satisfy the thermal state conditions

$$a|0_{eq}(\theta)\rangle = e^{-\omega/T(\theta)}\tilde{a}^\dagger|0_{eq}(\theta)\rangle, \quad (38)$$

$$\langle 1(\theta)|a^\dagger = \langle 1(\theta)|\tilde{a}. \quad (39)$$

The thermal vacuums  $\langle 1(\theta)|$  and  $|0_{eq}(\theta)\rangle$  are tilde-invariant:

$$\langle 1(\theta)|\sim = \langle 1(\theta)|, \quad |0_{eq}(\theta)\rangle\sim = |0_{eq}(\theta)\rangle. \quad (40)$$

For simplicity, we will confine the discussion to the case of Boson fields, which can be easily extended to Fermion fields.

The vacuums  $\langle 1(\theta)|$  and  $|0_{eq}(\theta)\rangle$  representing the canonical ensemble are defined by

$$\langle 1(\theta)|\tilde{\gamma}_\theta^\dagger = 0, \quad \gamma_\theta|0_{eq}(\theta)\rangle = 0, \quad (41)$$

with the creation operator  $\tilde{\gamma}_\theta^\dagger$  and the annihilation operator  $\gamma_\theta$  which are defined through the Bogoliubov transformation [1]- [4]

$$\gamma_\theta^\mu = B(\theta)^{\mu\nu} a^\nu, \quad \tilde{\gamma}_\theta^\mu = \bar{a}^\nu B^{-1}(\theta)^{\nu\mu}. \quad (42)$$

Here, we introduced the thermal doublet notations

$$\gamma_\theta^{\mu=1} = \gamma_\theta, \quad \gamma_\theta^{\mu=2} = \tilde{\gamma}_\theta^\dagger, \quad (43)$$

$$\tilde{\gamma}_\theta^{\mu=1} = \gamma_\theta^\dagger, \quad \tilde{\gamma}_\theta^{\mu=2} = -\tilde{\gamma}_\theta, \quad (44)$$

and the matrix

$$B(\theta)^{\mu\nu} = \begin{pmatrix} 1 + \bar{n}(\theta) & -\bar{n}(\theta) \\ -1 & 1 \end{pmatrix}. \quad (45)$$

Representing, for example, the number operators  $a^\dagger a$  with respect to this vacuum, we obtain

$$\langle 1(\theta) | a^\dagger a | 0_{eq}(\theta) \rangle = \bar{n}(\theta). \quad (46)$$

Using the thermal state conditions (38) and (39), we see that

$$\bar{n}(\theta) = \left( e^{\omega/T(\theta)} - 1 \right)^{-1}, \quad (47)$$

which is the thermal vacuums representing the canonical ensemble with temperature  $T(\theta)$ . Note that two representation spaces belonging to different parameter  $\theta$  are unitary-inequivalent [1-4].

Imagine a space constituted by the set of mutually inequivalent degenerate thermal vacuums  $|0_{eq}(\theta)\rangle$  specified by  $\bar{n}(T(\theta))$  having zero hat-energy, i.e.,  $\hat{E} = 0$ . The adiabatic change of the thermal equilibrium state specified by temperature  $T(\theta)$  to the one by  $T(\theta')$  can be interpreted as the change of the parameter  $\theta$  to  $\theta'$  in this space.

For non-equilibrium cases, thermal vacuum, which is not the zero hat-energy vacuum in general, is specified by the one-particle distribution function  $n_k(t)$ . Its different dependence in  $k$  gives mutually inequivalent vacuums. A participation of certain dissipative process makes it possible to connect these inequivalent vacuums in time as will be shown in the following.

## V. SEMI-FREE OPERATORS

Now, we consider, for simplicity, the case of a semi-free field

$$\varphi(x)^\mu = \int \frac{d^3k}{(2\pi)^{3/2}} e^{ik \cdot x} a_k(t)^\mu, \quad (48)$$

$$\bar{\varphi}(x)^\mu = \int \frac{d^3k}{(2\pi)^{3/2}} e^{-ik \cdot x} \bar{a}_k(t)^\mu, \quad (49)$$

accompanied by the equal-time commutation relation

$$[a_k(t)^\mu, \bar{a}_\ell(t)^\nu] = \delta^{\mu\nu} \delta(\mathbf{k} - \ell). \quad (50)$$

Here, we introduced the thermal doublet notation for the semi-free operators by

$$a_k(t)^{\mu=1} = a_k(t), \quad a_k(t)^{\mu=2} = \tilde{a}_k^\ddagger(t), \quad (51)$$

$$\bar{a}_k(t)^{\mu=1} = a_k^\ddagger(t), \quad \bar{a}_k(t)^{\mu=2} = -\tilde{a}_k(t). \quad (52)$$

The Heisenberg operators  $a_k(t)^\mu$  and  $\bar{a}_k(t)^\nu$  are defined by

$$a_k(t)^\mu = \hat{V}^{-1}(t) a_k^\mu \hat{V}(t), \quad \bar{a}_k(t)^\mu = \hat{V}^{-1}(t) \bar{a}_k^\mu \hat{V}(t), \quad (53)$$

where  $\hat{V}(t)$  satisfies

$$\frac{d}{dt} \hat{V}(t) = -i \hat{H}_t \hat{V}(t), \quad (i \hat{H}_t)^\sim = i \hat{H}_t, \quad (54)$$

with  $\hat{V}(0) = 1$ , i.e.,

$$a_k(t) = \hat{V}^{-1}(t) a_k \hat{V}(t), \quad \tilde{a}_k^\ddagger(t) = \hat{V}^{-1}(t) \tilde{a}_k^\dagger \hat{V}(t). \quad (55)$$

Note that  $a_k$  and  $\tilde{a}_k^\dagger$  do not depend on time. Since the semi-free hat-Hamiltonian  $\hat{H}_t$  is not necessarily Hermite, we introduced the symbol  $\ddagger$  in order to distinguish it from the Hermite conjugation  $\dagger$ . However in the following, we will use  $\dagger$  instead of  $\ddagger$ , for simplicity, unless it is confusing. We also drop the subscript representing momentum unless it is necessary.

It is known that the hat-Hamiltonian for the renormalized semi-free field is given by [8,9]

$$\hat{H}_t = \hat{H}_{0,t} + i \hat{\Pi}_t, \quad (56)$$

with

$$\hat{H}_{0,t} = \omega(t)\bar{a}^\mu a^\mu + \omega(t), \quad (57)$$

$$\hat{H}_t = -\bar{a}^\mu \left[ \kappa(t)A(t)^{\mu\nu} + \frac{dn(t)}{dt}\tau^{\mu\nu} \right] a^\nu + \kappa(t), \quad (58)$$

where the integration with respect to the momentum  $k$  is implicit. We introduced two matrices

$$A(t)^{\mu\nu} = \begin{pmatrix} 1 + 2n(t) & -2n(t) \\ 2(1 + n(t)) & -(1 + 2n(t)) \end{pmatrix}, \quad (59)$$

and,  $\tau^{11} = \tau^{21} = 1$ ,  $\tau^{12} = \tau^{22} = -1$ . Here,  $n(t)$  represents the one-particle distribution function which should be specified by the kinetic equation

$$\frac{d}{dt}n(t) = -2\kappa(t)n(t) + i\Sigma^<(t), \quad (60)$$

where the functions  $\kappa(t)$  and  $\Sigma^<(t)$  ( $\omega(t)$  also) are determined self-consistently when an interaction Hamiltonian is specified.

The equation of motion for the field is given by the Heisenberg equation

$$\frac{d}{dt}\varphi(x)^\mu = i[\hat{H}(t), \varphi(x)^\mu], \quad (61)$$

with

$$\hat{H}(t) = \hat{V}^{-1}(t)\hat{H}_t\hat{V}(t). \quad (62)$$

Then, the equation of motion for the semi-free operator  $a(t)^\mu$  becomes

$$\begin{aligned} \frac{d}{dt}a(t)^\mu &= -i[\omega(t)\delta^{\mu\nu} - i\kappa(t)A(t)^{\mu\nu}]a(t)^\nu \\ &\quad - \frac{dn(t)}{dt}\tau^{\mu\nu}a(t)^\nu. \end{aligned} \quad (63)$$

Introducing annihilation and creation operators

$$\gamma_t^{\mu=1} = \gamma_t, \quad \gamma_t^{\mu=2} = \tilde{\gamma}_t^\dagger, \quad (64)$$

$$\tilde{\gamma}_t^{\mu=1} = \gamma_t^\dagger, \quad \tilde{\gamma}_t^{\mu=2} = -\tilde{\gamma}_t, \quad (65)$$

in the Schrödinger representation through

$$\gamma_t^\mu = B(t)^{\mu\nu} a^\nu, \quad \tilde{\gamma}_t^\mu = \bar{a}^\nu B^{-1}(t)^{\nu\mu}, \quad (66)$$

with the *time-dependent Bogoliubov transformation*

$$B(t)^{\mu\nu} = \begin{pmatrix} 1 + n(t) & -n(t) \\ -1 & 1 \end{pmatrix}, \quad (67)$$

the hat-Hamiltonians (57) and (58) reduce, respectively, to [8,9]

$$\hat{H}_{0,t} = \int d^3k \omega_k(t) \left( \gamma_k^\dagger \gamma_{k,t} - \tilde{\gamma}_k^\dagger \tilde{\gamma}_{k,t} \right), \quad (68)$$

$$\hat{\Pi}_t = - \int d^3k \left[ \kappa_k(t) \left( \gamma_k^\dagger \gamma_{k,t} + \tilde{\gamma}_k^\dagger \tilde{\gamma}_{k,t} \right) - \frac{dn_k(t)}{dt} \gamma_k^\dagger \tilde{\gamma}_k^\dagger \right]. \quad (69)$$

The new operators annihilate the thermal vacuums  $|0(t)\rangle$  and  $\langle 1|$  as

$$\gamma_{k,t}|0(t)\rangle = 0, \quad \langle 1|\tilde{\gamma}_k^\dagger = 0, \quad (70)$$

respectively. The time-dependence of  $\gamma_t$  and  $\tilde{\gamma}_t$  comes from that of the one-particle distribution function  $n(t)$ :

$$\gamma_t = \gamma_{t=0} - [n(t) - n(0)] \tilde{\gamma}^\dagger. \quad (71)$$

Substituting the normal ordered expression of the hat-Hamiltonian (68) and (69) into the Schrödinger equation (1), we can obtain its solution as

$$\begin{aligned} |0(t)\rangle &= \hat{V}(t)|0\rangle \\ &= \exp \left\{ \int d^3k [n_k(t) - n_k(0)] \gamma_k^\dagger \tilde{\gamma}_k^\dagger \right\} |0\rangle. \end{aligned} \quad (72)$$

This expression tells us that the time-evolution of the unstable vacuum is realized by the condensation of  $\gamma_k^\dagger \tilde{\gamma}_k^\dagger$ -pairs into the vacuum. It also shows that the vacuum is the functional of the one-particle distribution function  $n_k(t)$ . The dependence of the thermal vacuum on  $n_k(t)$  is given by

$$\frac{\delta}{\delta n_k(t)} |0(t)\rangle = \gamma_k^\dagger \tilde{\gamma}_k^\dagger |0(t)\rangle. \quad (73)$$

We see that the vacuum  $|0(t)\rangle$  represents the state where exists the macroscopic object described by the one-particle distribution function  $n_k(t)$ .

The operators

$$\gamma(t)^\mu = \hat{V}^{-1}(t)\gamma_t^\mu\hat{V}(t), \quad \bar{\gamma}(t)^\mu = \hat{V}^{-1}(t)\bar{\gamma}_t^\mu\hat{V}(t), \quad (74)$$

in the Heisenberg representation with the thermal doublets,

$$\gamma(t)^{\mu=1} = \gamma(t), \gamma(t)^{\mu=2} = \tilde{\gamma}^\dagger(t), \quad (75)$$

$$\bar{\gamma}(t)^{\mu=1} = \gamma^\dagger(t), \bar{\gamma}(t)^{\mu=2} = -\tilde{\gamma}(t), \quad (76)$$

satisfy the equal-time commutation relation:

$$[\gamma(t)^\mu, \bar{\gamma}(t)^\nu] = \delta^{\mu\nu}, \quad (77)$$

and have the properties

$$\gamma(t)|0\rangle = 0, \quad \langle 1|\tilde{\gamma}^\dagger(t) = 0. \quad (78)$$

Note that the thermal vacuums are tilde invariant (see (40)).

The quasi-particle operators  $\gamma(t)^\mu$  satisfy the equation of motion

$$\frac{d}{dt}\gamma(t)^\mu = -i[\omega(t)\delta^{\mu\nu} - i\kappa(t)\tau_3^{\mu\nu}]\gamma(t)^\nu, \quad (79)$$

where the matrix  $\tau_3^{\mu\nu}$  is defined by  $\tau_3^{11} = -\tau_3^{22} = 1$ ,  $\tau_3^{12} = \tau_3^{21} = 0$ . The equation of motion (79) is solved to give

$$\gamma(t)^\mu = \exp\left\{\int_0^t ds [-i\omega(s)\delta^{\mu\nu} - \kappa(s)\tau_3^{\mu\nu}]\right\}\gamma(0)^\nu. \quad (80)$$

## VI. REFERENCE VACUUM

In order to put the part relating to the non-equilibrium and dissipative time-evolution into vacuum, we divide  $\hat{V}(t)$  into two parts:

$$\hat{V}(t) = \hat{V}_0(t)\hat{W}(t), \quad (81)$$

where  $\hat{V}_0(t)$  satisfies

$$\frac{d}{dt}\hat{V}_0(t) = -i\hat{H}_{0,t}\hat{V}_0(t). \quad (82)$$

Then, we see that  $\hat{W}(t)$  obeys

$$\frac{d}{dt}\hat{W}(t) = \hat{\Pi}(t)\hat{W}(t), \quad (83)$$

with

$$\hat{\Pi}(t) = \hat{V}_0^{-1}(t)\hat{\Pi}_t\hat{V}_0(t) = \hat{\Pi}_t, \quad (84)$$

where we used the commutativity

$$[\hat{H}_{0,t}, \hat{\Pi}_t] = 0. \quad (85)$$

Operators in this representation evolves in time as

$$a(t)^\mu = \hat{V}_0^{-1}(t)a^\mu\hat{V}_0(t) = a^\mu e^{-i\int_0^t ds \omega(s)}, \quad (86)$$

$$\gamma(t)^\mu = \hat{V}_0^{-1}(t)\gamma_t^\mu\hat{V}_0(t) = \gamma_t^\mu e^{-i\int_0^t ds \omega(s)}. \quad (87)$$

Here, we are using the same notation  $a(t)^\mu$  and  $\gamma(t)^\mu$  for the quasi-particle operators as those for the semi-free particle operators introduced in the previous section. We hope that they are not confusing.

We call the vacuum

$$\begin{aligned} |0(t)\rangle_{\text{ref}} &= \hat{W}(t)|0\rangle \\ &= \exp\left\{\int d^3k [n_k(t) - n_k(0)] \gamma_k^\dagger \tilde{\gamma}_k^\dagger\right\} |0\rangle, \end{aligned} \quad (88)$$

$${}_{\text{ref}}\langle 1| = \langle 1|\hat{V}_0(t) = \langle 1|, \quad (89)$$

the *reference vacuum* [22]. For the latter equation, we used the fact that

$$\langle 1|\hat{H}_{0,t} = 0. \quad (90)$$

The Schrödinger equation for the former vacuum  $|0(t)\rangle_{\text{ref}}$  can be rewritten as

$$\left\{\frac{\partial}{\partial t} + \int d^3k \frac{dn_k(t)}{dt} \frac{\delta}{\delta n_k(t)}\right\} |0(t)\rangle_{\text{ref}} = 0. \quad (91)$$

This shows that the reference vacuum, in this case, is migrating in the super-representation space spanned by the one-particle distribution function  $\{n_k(t)\}$  with the *velocity*  $\{dn_k(t)/dt\}$  as a conserved quantity. These vacuums satisfy

$$\text{ref}\langle 1|\tilde{\gamma}^\dagger(t) = 0, \quad \gamma(t)|0(t)\rangle_{\text{ref}} = 0. \quad (92)$$

For the case of a semi-free particle corresponding to a *stationary process* [5,6] where

$$i\Sigma^<(t) = 2\kappa\bar{n}, \quad \omega(t) = \omega, \quad \kappa(t) = \kappa, \quad (93)$$

the kinetic equation becomes

$$\frac{dn(t)}{dt} = 2\kappa [n(t) - \bar{n}]. \quad (94)$$

Then, the hat-Hamiltonian (56) reduces to

$$\hat{H} = \hat{H}_0 + i\hat{\Pi}, \quad (95)$$

with

$$\hat{H}_0 = H_0 - \tilde{H}_0, \quad H_0 = \omega a^\dagger a, \quad (96)$$

$$\begin{aligned} \hat{\Pi} = & -\kappa \left[ (1 + 2\bar{n}) (a^\dagger a + \tilde{a}^\dagger \tilde{a}) \right. \\ & \left. - 2(1 + \bar{n}) a\tilde{a} - 2\bar{n}a^\dagger\tilde{a}^\dagger \right] - 2\kappa\bar{n}. \end{aligned} \quad (97)$$

The time-dependence of the reference vacuum is given by

$$|0(t)\rangle_{\text{ref}} = \exp \left\{ [\bar{n} - n(0)] (1 - e^{-2\kappa t}) \gamma^\dagger \tilde{\gamma}^\dagger \right\} |0\rangle, \quad (98)$$

where  $\bar{n}$  is the one-particle distribution function of the final equilibrium state, say  $n(\theta)$  in section IV. For this simple case,  $|0(t)\rangle$  is determined by  $\bar{n}$ ,  $n(0)$  and  $\kappa$ . It is interesting if we put  $n(0) = n(\theta_0)$  and  $\bar{n} = n(\theta)$ , and remember that, in non-equilibrium thermodynamics, the thermodynamical states are specified only by its initial and final states.

The representation space (the thermal space) of NETFD is the vector space spanned by the set of bra and ket state vectors which are generated, respectively, by cyclic operations



of the annihilation operators  $\gamma(t)$  and  $\tilde{\gamma}(t)$  on  ${}_{\text{ref}}\langle 1|$ , and of the creation operators  $\gamma^\dagger(t)$  and  $\tilde{\gamma}^\dagger(t)$  on  $|0(t)\rangle_{\text{ref}}$ .

The normal product is defined by means of the annihilation and the creation operators, i.e.  $\gamma^\dagger(t)$ ,  $\tilde{\gamma}^\dagger(t)$  stand to the left of  $\gamma(t)$ ,  $\tilde{\gamma}(t)$ . The process, rewriting physical operators in terms of the annihilation and creation operators, leads to a Wick-type formula, which in turn leads to Feynman-type diagrams for multi-point functions in the renormalized interaction representation. The internal line in the Feynman-type diagrams is the unperturbed two-point function (the propagator):

$$\begin{aligned} G(t, t')^{\mu\nu} &= -i\langle 1|T [a(t)^\mu \bar{a}(t')^\nu \hat{W}(\bullet)] |0\rangle_{\text{ref}} \\ &= [B^{-1}(t)\mathcal{G}(t, t')B(t')]^{\mu\nu}, \end{aligned} \quad (99)$$

where

$$\begin{aligned} \mathcal{G}(t, t')^{\mu\nu} &= -i\langle 1|T [\gamma(t)^\mu \tilde{\gamma}(t')^\nu \hat{W}(\bullet)] |0\rangle_{\text{ref}} \\ &= \begin{pmatrix} G^R(t, t') & 0 \\ 0 & G^A(t, t') \end{pmatrix}, \end{aligned} \quad (100)$$

with

$$\begin{aligned} G^R(t, t') &= -i\theta(t - t') \exp \left\{ \int_{t'}^t ds [-i\omega(s) - \kappa(s)] \right\}, \end{aligned} \quad (101)$$

$$\begin{aligned} G^A(t, t') &= i\theta(t' - t) \exp \left\{ \int_{t'}^t ds [-i\omega(s) + \kappa(s)] \right\}. \end{aligned} \quad (102)$$

Here, the time argument  $\bullet$  represents a time which is larger than  $t$  and  $t'$ .

## VII. DYNAMICAL MAPPING

Within the reference vacuum representation, we have

$$a(t) = \gamma(t) + n(t)\tilde{\gamma}^\dagger(t), \quad (103)$$

$$\bar{a}^\dagger(t) = \{1 + n(t)\}\tilde{\gamma}^\dagger(t) + \gamma(t), \quad (104)$$

which can be interpreted as the dynamical mapping of the operators of  $a(t)$  and  $\tilde{a}^\dagger(t)$  with respect to the reference vacuum  ${}_{\text{ref}}\langle 1|$  and  $|0(t)\rangle_{\text{ref}}$ . The fact that the reference vacuum is specified by the one-particle distribution function  $n(t)$  is shown in the dynamical mapping

$$\begin{aligned} a^\dagger(t)a(t) &= n(t) + \{1 + n(t)\} \gamma^\ddagger(t)\gamma(t) \\ &\quad + n(t)\tilde{\gamma}^\ddagger(t)\tilde{\gamma}(t) \\ &\quad + n(t) \{1 + n(t)\} \gamma^\ddagger(t)\tilde{\gamma}^\ddagger(t) + \gamma(t)\tilde{\gamma}(t). \end{aligned} \quad (105)$$

The dynamical mapping of the fluctuation is given by

$$\begin{aligned} a^\dagger(t)a(t)a^\dagger(t)a(t) - {}_{\text{ref}}\langle 1|a^\dagger(t)a(t)|0(t)\rangle_{\text{ref}}^2 \\ = n(t) \{1 + n(t)\} + [\text{normal ordered series}]. \end{aligned} \quad (106)$$

## VIII. AN INTERPRETATION OF THE REFERENCE VACUUM REPRESENTATION

In order to understand the physical meaning of the reference vacuum, we will consider, for a moment, the Schrödinger equation

$$\frac{\partial}{\partial t}|0(t)\rangle = -i(\hat{H}_0 + \epsilon\hat{H}_1)|0(t)\rangle, \quad (107)$$

with  $\epsilon \ll 1$ .

Let us suppose that the vacuum  $|0(t)\rangle$  depends on two *independent* time variables  $t_0$  and  $t_1$ :

$$|0(t)\rangle \rightarrow |0(t_0, t_1)\rangle, \quad (108)$$

where  $t_0$  represents a fast (or microscopic) time scale and  $t_1$  a slow (or macroscopic) time scale. The *slow* and *fast* in time scale is introduced with respect to the small parameter  $\epsilon$ . Then, the time derivative will be given by

$$\frac{\partial}{\partial t} = \frac{\partial}{\partial t_0} + \epsilon \frac{\partial}{\partial t_1}. \quad (109)$$

Physical axis can be provided by putting  $t_0 = t$  and  $t_1 = \epsilon t$  at an appropriate stage.

Expanding the vacuum with respect to  $\epsilon$ :

$$|0(t_0, t_1)\rangle = |0(t_0, t_1)\rangle_0 + \epsilon|0(t_0, t_1)\rangle_1, \quad (110)$$

we obtain the equations of order of  $\epsilon^0$  and of  $\epsilon^1$ , respectively, in the forms

$$\frac{\partial}{\partial t_0}|0(t_0, t_1)\rangle_0 = -i\hat{H}_0|0(t_0, t_1)\rangle_0, \quad (111)$$

$$\begin{aligned} \frac{\partial}{\partial t_0}|0(t_0, t_1)\rangle_1 + i\hat{H}_0|0(t_0, t_1)\rangle_1 \\ = -\frac{\partial}{\partial t_1}|0(t_0, t_1)\rangle_0 - i\hat{H}_1|0(t_0, t_1)\rangle_0. \end{aligned} \quad (112)$$

The solution of (111) is given by

$$|0(t_0, t_1)\rangle_0 = e^{-i\hat{H}_0 t_0}|0(t_1)\rangle_0. \quad (113)$$

Note that the vacuum  $|0(t_1)\rangle_0$  appeared on the right-hand side depends only on the slow time  $t_1$ .

Substituting (113) into the right-hand side of (112), we have inhomogeneous terms which should be vanished unless they give rise to secular divergence. Then, we obtain the equation which determines the  $t_1$ -dependence of  $|0(t_1)\rangle_0$  in the form

$$\frac{\partial}{\partial t_1}|0(t_1)\rangle_0 = -i\hat{H}_1(t_0)|0(t_1)\rangle_0, \quad (114)$$

with

$$\hat{H}_1(t_0) = e^{i\hat{H}_0 t_0} \hat{H}_1 e^{-i\hat{H}_0 t_0}. \quad (115)$$

The solution

$$|0(t_1)\rangle_0 = e^{-i\hat{H}_1(t_0)t_1}|0\rangle_0, \quad (116)$$

of (114) gives the time-dependence of the reference vacuum. This slow time-dependence may be related to that of macroscopic (or semi-macroscopic) objects. The point is that we put this slow time-dependent part into one of the characteristics of the reference vacuum.

Since the inhomogeneous terms in (112) has been taken out, the equation for  $|0(t_0, t_1)\rangle_1$  reduces to

$$\frac{\partial}{\partial t_0} |0(t_0, t_1)\rangle_1 = -i\hat{H}_0 |0(t_0, t_1)\rangle_1. \quad (117)$$

The vacuum  $|0(t_1)\rangle_1$  which appears in the solution of this equation is determined by the secular terms in the equation of order of  $\epsilon^2$ .

It is necessary to determine the dynamics with respect to the fast time variable  $t_0$  and the one with respect to the slow time variable  $t_1$  self-consistently in the sense that the thermalization of the reference vacuum and the microscopic time-evolution become mutually consistent on the physical axis. There are similar interpretations supporting this point of view. The time-evolution of a vacuum specified by the stochastic Liouville equation is controlled by a random process whose time index is semi-macroscopic [17–19].

Note that the separation of time scale into two is intimately related to the Boltzmann equation limit. If this limit is not appropriate, as in the hydrodynamical regime, one needs to introduce more independent time variables which may leads to multiple time-scale analysis [42,43]. In the hydrodynamical regime, the vacuum describing non-equilibrium thermodynamic processes is a functional of the space and time dependent thermodynamic quantities, e.g., the local temperature, the local pressure, the local chemical potential, the local fluid velocity and so on [15]. The space and time indices of these quantities are macroscopic.

## IX. COMMENTS AND FUTURE PROBLEMS

We introduced in this paper one of the new concepts revealed by the development of NETFD, the concept of migration of unstable vacuum, which is inevitable for the dissipative quantum systems in far-from equilibrium states. The concept was clearly stated by the expression (91) which shows that in the kinetic regime the reference vacuum migrates with the velocity  $dn_k(t)/dt$  as a conserved quantity in the super-representation space spanned by the one-particle distribution function  $n_k(t)$ . In order to understand the migration among inequivalent representation spaces, it is required to extend the concept of dynamical mapping for dissipative non-equilibrium systems, which was initiated in this paper. In this respect, an extension of the mechanism and of the concept in the appearance of macroscopic objects due to the Boson transformation to non-equilibrium dissipative situations is one of the attractive future problems. It is also necessary to extend the present approach to cope with phenomena in the hydrodynamical regime [15],

such as dense fluid, dense nuclear matter, dense plasma and so on.

The formulation of NETFD has a wide potentiality in the sense that it may provide us with a technical tool telling how to extend the concepts revealed in the usual quantum field theory to dissipative non-equilibrium cases. The discovery that the time-evolution of unstable vacuum is realized by the condensation of  $\gamma_k^{\pm} \tilde{\gamma}_k^{\pm}$ -pairs into the vacuum is one of the examples. We hope that with the help of NETFD we can find out a breakthrough to realize Boltzmann's original dream, i.e., the essential understanding of irreversibility. The notion of the dual structure in quantum field theory, the operator algebra and the representation space, was not recognized in Boltzmann's days.

### ACKNOWLEDGMENTS

The authors would like to thank Dr. N. Arimitsu, Dr. T. Saito, Dr. A. Tanaka, Mr. T. Imagire, Mr. T. Indei and Mr. Y. Endo for their collaboration with fruitful discussions.

### APPENDIX A: RELATION TO PATH INTEGRAL

The kernel

$$K(\alpha, \beta, t; \alpha', \beta', t') = (\alpha, \beta | e^{-i\hat{H}(t-t')} | \alpha', \beta'). \quad (\text{A1})$$

defined by

$$\begin{aligned} & (\alpha, \beta | 0(t)) \\ &= \int \frac{d^2\alpha'}{\pi} \int \frac{d^2\beta'}{\pi} K(\alpha, \beta, t; \alpha', \beta', 0) (\alpha', \beta' | 0) \end{aligned} \quad (\text{A2})$$

can be expressed in terms of path integral. Here, we introduced the coherent state by

$$|\alpha, \beta\rangle = e^{\alpha a^\dagger - \alpha^* a} e^{\beta^* \tilde{a}^\dagger - \beta \tilde{a}} |0, \tilde{0}\rangle, \quad (\text{A3})$$

with

$$a|\alpha, \beta\rangle = \alpha|\alpha, \beta\rangle, \quad \tilde{a}|\alpha, \beta\rangle = \beta^*|\alpha, \beta\rangle \quad (\text{A4})$$

$$(\alpha, \beta | a^\dagger = (\alpha, \beta | \alpha^*, \quad (\alpha, \beta | \tilde{a}^\dagger = (\alpha, \beta | \beta. \quad (\text{A5})$$

By making use of

$$\begin{aligned} & (\alpha_n, \beta_n | \alpha_{n-1}, \beta_{n-1}) \\ &= e^{-\frac{1}{2}|\alpha_n|^2 - \frac{1}{2}|\alpha_{n-1}|^2 + \alpha_n^* \alpha_{n-1}} \\ & \quad \times e^{-\frac{1}{2}|\beta_{n-1}|^2 - \frac{1}{2}|\beta_n|^2 + \beta_{n-1}^* \beta_n} \end{aligned} \quad (\text{A6})$$

and

$$\begin{aligned} & h_{n,n-1}(\alpha_n, \beta_n | \alpha_{n-1}, \beta_{n-1}) \\ &= (\alpha_n, \beta_n | \hat{H} | \alpha_{n-1}, \beta_{n-1}) \\ &= \left\{ \omega \alpha_n^* \alpha_{n-1} - \omega \beta_n \beta_{n-1}^* \right. \\ & \quad \left. - i\kappa \left[ (1 + 2\bar{n})(\alpha_n^* \alpha_{n-1} + \beta_n \beta_{n-1}^*) \right. \right. \\ & \quad \left. \left. - 2(1 + \bar{n})\alpha_{n-1} \beta_{n-1}^* - 2\bar{n}\alpha_n^* \beta_n \right] - 2i\kappa\bar{n} \right\} \\ & \quad \times (\alpha_n, \beta_n | \alpha_{n-1}, \beta_{n-1}) \end{aligned} \quad (\text{A7})$$

the path integral

$$\begin{aligned} & K(\alpha, \beta, t; \alpha', \beta', t') \\ &= \lim_{N \rightarrow \infty} \left( \prod_{i=1}^{N-1} \int \frac{d^2 \alpha_i}{\pi} \right) \left( \prod_{j=1}^{N-1} \int \frac{d^2 \beta_j}{\pi} \right) \\ & \quad \times (\alpha_N, \beta_N | \alpha_{N-1}, \beta_{N-1}) \cdots (\alpha_1, \beta_1 | \alpha_0, \beta_0) \\ & \quad \times \exp \left[ -i\Delta t \sum_{n=1}^{N-1} h_{n,n-1} \right] \\ &= e^{-\frac{1}{2}|\alpha|^2 - \frac{1}{2}|\alpha'|^2 - \frac{1}{2}|\beta|^2 + \frac{1}{2}|\beta'|^2} \int \mathcal{D}^2 \alpha \int \mathcal{D}^2 \beta \\ & \quad \times \exp \left[ i \int_{t'}^t dt \left[ i\alpha^*(t) \dot{\alpha}(t) - i\beta^*(t) \dot{\beta}(t) \right. \right. \\ & \quad \left. \left. - \alpha(t) \{ \omega \alpha^*(t) - i\kappa(1 + 2\bar{n})\alpha^*(t) + 2i\kappa(1 + \bar{n})\beta^*(t) \} \right. \right. \\ & \quad \left. \left. - \beta(t) \{ -\omega \beta^*(t) - i\kappa(1 + 2\bar{n})\beta^*(t) + 2i\kappa\bar{n}\alpha^*(t) \} \right. \right. \\ & \quad \left. \left. - 2\kappa\bar{n} \right] \right]. \end{aligned} \quad (\text{A8})$$

can be solved with the help of the equations of motion

$$\frac{d}{dt} \begin{pmatrix} \alpha^*(t) \\ \beta^*(t) \end{pmatrix} = \Omega \begin{pmatrix} \alpha^*(t) \\ \beta^*(t) \end{pmatrix}. \quad (\text{A9})$$

$$\Omega = \begin{pmatrix} \omega - i\kappa(1 + 2\bar{n}) & 2i\kappa(1 + \bar{n}) \\ -2i\kappa\bar{n} & \omega + i\kappa(1 + 2\bar{n}) \end{pmatrix} \quad (\text{A10})$$

with the boundary conditions

$$\begin{aligned} \alpha^*(t) &= \alpha^*, & \alpha(t') &= \alpha' \\ \beta^*(t') &= \beta^*, & \beta(t) &= \beta. \end{aligned} \quad (\text{A11})$$

The result is

$$\begin{aligned} K(\alpha, \beta, t; \alpha', \beta', t') &= \nu(t - t') \exp \left[ -\frac{1}{2}|\alpha|^2 - \frac{1}{2}|\alpha'|^2 - \frac{1}{2}|\beta|^2 - \frac{1}{2}|\beta'|^2 \right. \\ &\quad \left. + k_i(t - t') \beta'^* \alpha' + k_f(t - t') \alpha^* \beta \right. \\ &\quad \left. + \ell(t - t') \alpha^* \alpha' + \ell^*(t - t') \beta'^* \beta \right] \end{aligned} \quad (\text{A12})$$

where

$$k_i(t) = (1 + \bar{n})\nu(t) (1 - e^{-2\kappa t}) \quad (\text{A13})$$

$$k_f(t) = \bar{n}\nu(t) (1 - e^{-2\kappa t}) \quad (\text{A14})$$

$$\ell(t) = \nu(t) e^{-i\omega t - \kappa t} \quad (\text{A15})$$

$$\nu(t) = \frac{1}{(1 + \bar{n}) - \bar{n}e^{-2\kappa t}}. \quad (\text{A16})$$

Then, we finally obtain

$$\begin{aligned} &\langle \alpha, \beta | 0(t) \rangle \\ &= \int \frac{d^2\alpha'}{\pi} \int \frac{d^2\beta'}{\pi} K(\alpha, \beta, t; \alpha', \beta', 0) \langle \alpha', \beta' | 0 \rangle \\ &= \frac{1}{1 + n(t)} e^{-\frac{1}{2}|\alpha|^2 - \frac{1}{2}|\beta|^2 + \frac{n(t)}{1+n(t)}\alpha^*\beta} \end{aligned} \quad (\text{A17})$$

## APPENDIX B: QUANTUM BROWNIAN MOTION

Let us introduce the annihilation and creation operators  $b_t, b_t^\dagger$  and their tilde conjugates satisfying the canonical commutation relation:

$$[b_t, b_{t'}^\dagger] = \delta(t - t'), \quad [\tilde{b}_t, \tilde{b}_{t'}^\dagger] = \delta(t - t'). \quad (\text{B1})$$

The vacuums ( $|$  and  $\tilde{|}$ ) are defined by

$$b_t| = 0, \quad \tilde{b}_t\tilde{|} = 0, \quad (|b_t^\dagger = \langle\tilde{b}_t. \quad (\text{B2})$$

The argument  $t$  represents time.

Introducing the operators

$$B_t = \int_0^{t-dt} dB_{t'} = \int_0^t dt' b_{t'}, \quad (\text{B3})$$

$$B_t^\dagger = \int_0^{t-dt} dB_{t'}^\dagger = \int_0^t dt' b_{t'}^\dagger, \quad (\text{B4})$$

and their tilde conjugates for  $t \geq 0$ , we see that they satisfy  $B(0) = 0$ ,  $B^\dagger(0) = 0$ ,

$$[B_s, B_t^\dagger] = \min(s, t), \quad (\text{B5})$$

and their tilde conjugates, and that they annihilate the vacuum  $\tilde{|}$  with the thermal state condition for  $\langle|$ :

$$dB_t\tilde{|} = 0, \quad d\tilde{B}_t\tilde{|} = 0, \quad \langle|dB_t^\dagger = \langle|d\tilde{B}_t. \quad (\text{B6})$$

These operators represent the quantum Brownian motion.

Let us introduce a set of new operators by the relation

$$dC_t^\mu = \mathcal{B}^{\mu\nu} dB_t^\nu, \quad (\text{B7})$$

with the Bogoliubov transformation defined by

$$\mathcal{B}^{\mu\nu} = \begin{pmatrix} 1 + \bar{n} & -\bar{n} \\ -1 & 1 \end{pmatrix}, \quad (\text{B8})$$

where  $\bar{n}$  is the Planck distribution function. We introduced the thermal doublet:

$$dB_t^{\mu=1} = dB_t, \quad dB_t^{\mu=2} = d\tilde{B}_t^\dagger, \quad (\text{B9})$$

$$d\tilde{B}_t^{\mu=1} = dB_t^\dagger, \quad d\tilde{B}_t^{\mu=2} = -d\tilde{B}_t, \quad (\text{B10})$$

and the similar doublet notations for  $dC_t^\mu$  and  $d\tilde{C}_t^\mu$ . The new operators annihilate the new vacuum  $\langle|$ , and have the thermal state condition for  $\tilde{|}$ :



$$dC_t|\rangle = 0, \quad d\tilde{C}_t|\rangle = 0, \quad \langle|dC_t^\dagger = \langle|d\tilde{C}_t. \quad (\text{B11})$$

We will use the representation space constructed on the vacuums  $\langle|$  and  $|\rangle$ . Then, we have, for example,

$$\langle|dB_t|\rangle = \langle|dB_t^\dagger|\rangle = 0, \quad (\text{B12})$$

$$\langle|dB_t^\dagger dB_t|\rangle = \bar{n}dt, \quad \langle|dB_t dB_t^\dagger|\rangle = (\bar{n} + 1)dt. \quad (\text{B13})$$

- [1] H. Umezawa, H. Matsumoto and M. Tachiki, *Thermo Field Dynamics and Condensed States* (North-Holland 1982).
- [2] H. Umezawa, *Advanced Field Theory — Micro, Macro, and Thermal Physics* — (American Institute of Physics 1993), and the references therein.
- [3] L. Leplae, H. Umezawa and F. Mancini, *Physics Reports* **10C**, 153 (1974).
- [4] Y. Takahashi and H. Umezawa, *Collect. Phenom.* **2**, 55 (1975).
- [5] T. Arimitsu and H. Umezawa, *Prog. Theor. Phys.* **74**, 429 (1985).
- [6] T. Arimitsu and H. Umezawa, *Prog. Theor. Phys.* **77**, 32 (1987).
- [7] T. Arimitsu and H. Umezawa, *Prog. Theor. Phys.* **77**, 53 (1987).
- [8] T. Arimitsu, M. Guida and H. Umezawa, *Europhys. Lett.* **3**, 277 (1987).
- [9] T. Arimitsu, M. Guida and H. Umezawa, *Physica* **A148**, 1 (1988).
- [10] T. Arimitsu and H. Umezawa, *J. Phys. Soc. Japan* **55**, 1475 (1986).
- [11] T. Arimitsu, H. Umezawa and Y. Yamanaka, *J. Math. Phys.* **28**, 2741 (1987).
- [12] T. Arimitsu, J. Pradko and H. Umezawa, *Physica* **A135**, 487 (1986).
- [13] T. Arimitsu, *Physica* **A148**, 427 (1988).

- [14] T. Arimitsu, *Physica* **A158** (1989) 317.
- [15] T. Arimitsu, *J. Phys. A: Math. Gen.* **24**, L1415 (1991).
- [16] T. Arimitsu, *Thermal Field Theories*, eds. H. Ezawa, T. Arimitsu and Y. Hashimoto (North-Holland, 1991) 207.
- [17] T. Arimitsu, *Phys. Lett.* **A153**, 163 (1991).
- [18] T. Saito and T. Arimitsu, *Modern Phys. Lett. B* **6**, 1319 (1992).
- [19] T. Arimitsu, *Condensed Matter Physics (Lviv, Ukraine)* **4** (1994) 26, and the references therein.
- [20] T. Saito and T. Arimitsu, *J. Phys. A: Math. Gen.* **30**, 7573 (1997). T. Saito and T. Arimitsu.
- [21] T. Imagire, T. Saito, K. Nemoto and T. Arimitsu, *Physica A* **256**, 129 (1997).
- [22] T. Arimitsu, *Physics Essays* **9**, 591 (1996).
- [23] T. Arimitsu, Y. Sudo and H. Umezawa, *Physica* **146A**, 433 (1987).
- [24] T. Tominaga, M. Ban, T. Arimitsu, J. Pradko and H. Umezawa. *Physica* **149A**, 26 (1988).
- [25] M. Ban and T. Arimitsu, *Physica* **146A**, 89 (1987).
- [26] T. Tominaga, T. Arimitsu, J. Pradko and H. Umezawa, *Physica* **A150**, 97 (1988).
- [27] T. Iwasaki, T. Arimitsu and F.H. Willeboordse, *Thermal Field Theories*, ed. H. Ezawa, T. Arimitsu and Y. Hashimoto (North-Holland 1991) 459.
- [28] T. Arimitsu, F.H. Willeboordse and T. Iwasaki, *Physica A* **182**, 214 (1992).
- [29] T. Arimitsu and N. Arimitsu, *Phys. Rev. E* **50**, 121 (1994).
- [30] T. Saito and T. Arimitsu, *Mod. Phys. Lett. B* **7**, 623 (1993).
- [31] T. Arimitsu, Proceedings of the *International Conference on Stochastic Processes and Their Applications* at Chennai (Madras) in India, (1998) in press.

- [32] T. Satio and T. Arimitsu, Proceedings of the *International Conference on Stochastic Processes and Their Applications at Chennai (Madras) in India*, (1998) in press.
- [33] F. Haake, *Springer Tracts in Modern Physics*, vol. 66 (Springer-Verlag, 1973) 98.
- [34] F. Shibata and T. Arimitsu, *J. Phys. Soc. Japan* **49**, 891 (1980).
- [35] T. Arimitsu, *J. Phys. Soc. Japan* **51**, 1720 (1982).
- [36] J. Schwinger, *J. Math. Phys.* **2**, 407 (1961).
- [37] L. V. Keldysh, *Sov. Phys. JETP* **20**, 1018 (1965).
- [38] K. Chou, Z. Su, B. Hao and L. Yu, *Phys. Rep.* **118**, 1 (1985).
- [39] Zubarev and Tokarchuk admired the method of NETFD, and they also started to use it for the investigation of these regions [40] (see also [41] for the application to the problem of the quark-gluon plasma).
- [40] D. N. Zubarev and M. V. Tokarchuk, *Theor. Math. Phys.* **88**, 876 (1991).
- [41] M. V. Tokarchuk, (1993) Lviv, preprint (ICMP-93-7E).
- [42] L. Bocquet, J. Piasecki and J-P. Hansen, *J. Stat. Phys.* **76**, 505 (1994).
- [43] L. Bocquet, J-P. Hansen and J. Piasecki, *J. Stat. Phys.* **76**, 527 (1994).