

Title	<Original>Studies on the Autecology of <i>Lyctus brunneus</i> (STEPHENS) (Coleoptera, Lyctidae) : VI. Larval Development and Instars with Special Reference to an Individual Rearing Method
Author(s)	IWATA, Ryutarō; NISHIMOTO, Koichi
Citation	Wood research : bulletin of the Wood Research Institute Kyoto University (1985), 71: 32-45
Issue Date	1985-02-28
URL	<a href="http://hdl.handle.net/2433/53319">http://hdl.handle.net/2433/53319</a>
Right	
Type	Departmental Bulletin Paper
Textversion	publisher

# Studies on the Autecology of *Lyctus brunneus* (STEPHENS) (Coleoptera, Lyctidae)

## VI. Larval Development and Instars with Special Reference to an Individual Rearing Method\*

Ryûtarô IWATA\*\* and Koichi NISHIMOTO\*\*

(Received November 5, 1984)

**Abstract**—The larval development and instar number of the powder-post beetle, *Lyctus brunneus* (STEPHENS) were investigated mainly by the “individual rearing method” with powder-state diet and a gelatin capsule.

Most of the larvae reared by this method passed through 4–6 instars under constant conditions of 24.5°C and 70% R.H. though a few exceptionally had much more instars. In general, larval instar number varied among individuals, and tended to increase with the prolonged larval period.

When larvae were in starving condition and/or in want of support for boring action, they showed supernumerary molts and weight decrease, resulting in death. Prepupa could pupate readily even without the support. The pupal duration in the present condition was ca. 10–12 days.

SEM observation showed morphological changes of palpi, antennae and legs in the course of larval development with succeeding instars.

### 1. Introduction

In order to develop the control method of the most important dry-wood boring beetle in Japan, *Lyctus brunneus* (STEPHENS), many kinds of control bioassays have been carried out. As only larvae of the lyctid species cause damage to timber, the bioassay with larvae is one of the most important test methods for developing potential chemicals.

In the laboratory tests of chemicals using larvae of *Lyctus brunneus*, however, sufficiently satisfactory results seem to have been unobtainable<sup>1)</sup>, and the same inconvenience was encountered in the test of artificial diet suitability<sup>2)</sup>. This is presumably due to diversities of age, activity and adaptability of the larvae prepared for the experiments. Precise knowledge of larval development, particularly the larval instar, therefore, is indispensable for minimizing the variance or diversity among larvae.

\* Presented at the 43rd Annual Meeting of the Entomological Society of Japan in Hirosaki, Sept., 1983.

\*\* Research Section of High Performance Wood Products, Wood Research Institute, Kyoto University, Uji, Kyôto, Japan.

Information so far obtained still seems very insufficient and improper to resolve this problem. Lyctid larvae show a kind of “polymetaboly”<sup>3)</sup>, a slight change of body shape<sup>4-6)</sup> between the 1st and 2nd instars. Regardless of this XAMBEU<sup>7)</sup> stated that larva of *Lyctus linearis* (GOEZE) (as *L. canaliculatus* FABRICIUS) molted 3 to 4 times by the end of winter though he did not describe the research method. TSCHOLL<sup>8)</sup> stated *L. brunneus* larva molted 5 to 8 times in the course of its development. He later classified *L. brunneus* larvae, reared with an artificial diet and under constant climatic condition, into 6 instars, and showed leaps in body weight increase at molts<sup>9)</sup> though it is doubtful that molt could cause such a leap. Finally, SUZUKI<sup>10)</sup> tried to investigate the larval instar number of *L. brunneus*, reared with buckwheat cake<sup>11)</sup>, and estimated the final stage to be the 4th instar although this estimation seems to include some improper points as regard to the interpretation of the data and the citation of our paper<sup>2)</sup>.

For the study of the larval instar of coleopterous species in general, grouping the dimensions of head capsules or exuvial mandibles of the larvae seems to have been a common method for this purpose, as was adopted by SUZUKI<sup>10)</sup> for *Lyctus* and by Keizô KOJIMA and his co-workers<sup>12-26)</sup> for Japanese cerambycid species. In some cases<sup>13,22,23,26)</sup>, however, a difficulty was encountered in grouping the larvae due to the individual variation, which may be mostly ascribed to the variance of moisture or nutritional conditions of food<sup>27)</sup>.

Therefore, in conducting the research on larval instars of *Lyctus brunneus*, a species that is expected to show a wide variation<sup>3)</sup>, the larval development should be followed individually and closely, where pairs of exuvial mandibles, which are mostly preserved in perfect form, enables an estimation of the larval instar. For easier inspection of the larvae, rearing method with powder-state matrix seems ideal, and in combination with it, a narrow-spaced container is needed because rearing with powder-state matrix in a voluminous container resulted in failure of development. As a container a small gelatin capsule, rather than a narrow glass tube<sup>28)</sup>, was adopted because the former was more suitable for isolation of each individual larva, and thus exuviae derived from a single larva could be collected. Here we call it an “individual rearing method”.

As the powder material buckwheat flour, which was already introduced by SUZUKI<sup>10,11)</sup>, preliminarily proved to be efficient, enabling larvae to develop and to pupate within the capsule, while trials of some other powder compositions, which were utilized to form solid artificial diets of *L. brunneus*, resulted in failure of development.

The present paper reports the results of the investigation on instars, weight change and morphological changes in the course of larval development of *L. brunneus*, with reference to the individual rearing method with gelatin capsules and buckwheat flour.

In the morphological investigation SEM was used to obtain more detailed information.

## 2. Materials and Methods

### 2.1 Experiment with wood blocks

Test blocks, measuring ca. 1.0–1.5 × ca. 10 × ca. 4 cm, were cut from oak (*Quercus serrata* MURRAY) sapwood. Holes of ca. 2.0–2.5 mm diameter and ca. 2.0 cm depth were bored on the selected blocks as shown in Fig.1-a. Larvae of various developmental stages were taken out from the mass culture<sup>29)</sup>, and each was accommodated in a hole of wood blocks, with no stuffing material used. The holes were sealed with cellophane adhesive tapes, to which a small circle of transparent vinyl sheet was attached to avoid sticking of the larvae on the tape (Fig. 1-b).

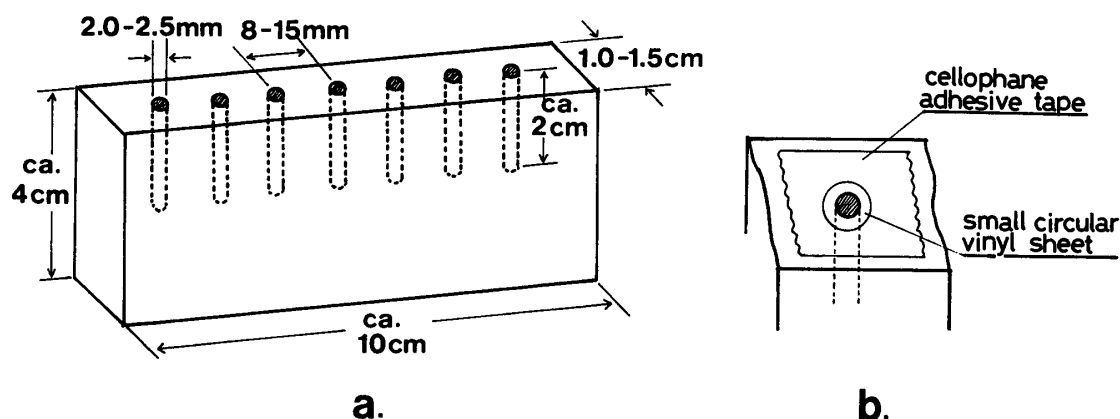

Fig. 1. Wood blocks with holes accommodating the larvae.

The blocks were kept in the mass culture chamber<sup>29)</sup> (24.5°C, 70% R.H.). Larvae and their exuviae were examined mostly at 2–5 days' interval, and each insect was weighed with the chemical balance.

### 2.2 Experiment with capsule and buckwheat flour (Individual rearing method)

#### 2.2.1. Capsules and buckwheat flour

Gelatin capsule used as a container in the individual rearing method is shown in Fig. 2.

Buckwheat (*Fagopyrum*) flour used was identical with that described in the previous report<sup>30)</sup>. The powder lot was passed through a mesh No. 200 (passing particles of less than 150  $\mu$  diameter) and was sufficiently homogenized. About 0.19 g of flour could be stuffed in an above capsule (ca. 0.21 cm<sup>3</sup> in volume), thus resulting in ca. 0.90 g/cm<sup>3</sup> of density of the powder.

#### 2.2.2. Insect supply

Parent beetles of the larvae were obtained from the mass culture<sup>29)</sup> with the new standard diet cake for the rearing of this species<sup>30)</sup>.

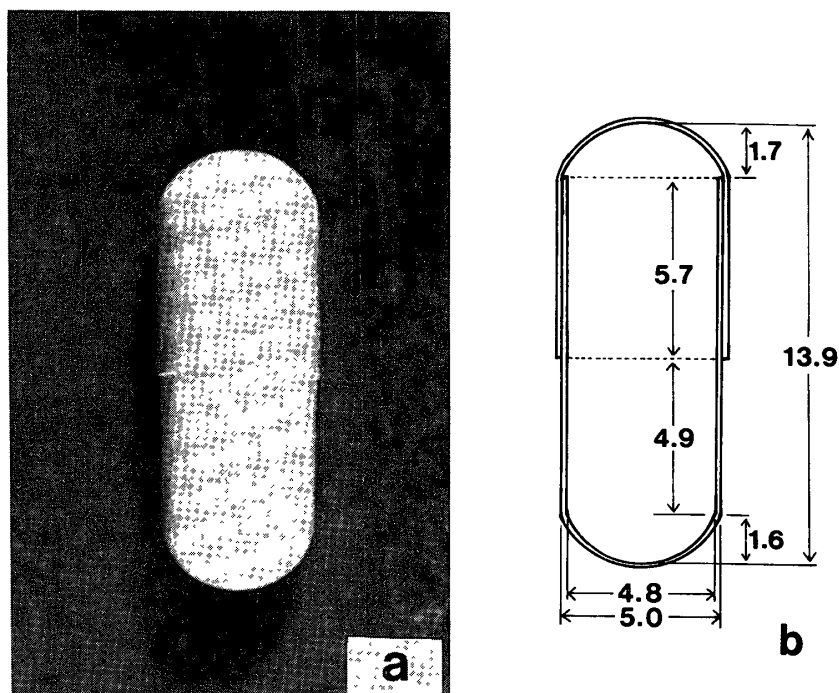

Fig. 2. Gelatin capsule used in the "individual rearing method". a, photograph of a capsule in rearing situation: stuffed with buckwheat flour; b, schematic diagram of a capsule with minimum volume of content, dimensions in mm.

Larvae were collected with the aid of "veneer technique"<sup>31)</sup> as was practically utilized previously<sup>32)</sup>. In consideration of the developmental periods of eggs<sup>33)</sup> and 1st instar larvae<sup>4)</sup>, the veneers were opened up to collect the 1st instar larvae 12–13 days after the parent beetles were released. The veneers also produced 2nd instar larvae at that time, which were excluded by distinguishing them from the 1st instar ones by the curled body shape\* and the absence of the "egg-tooth" on the 9th abdominal segment<sup>3)</sup>.

These young larvae, weighing less than 0.1 mg, were carefully removed with a specially devised pincette made of an animal hair, and a single larva was confined into each capsule stuffed densely with buckwheat flour.

### 2.2.3. Rearing and inspection methods

Every capsule with buckwheat flour and a single larva was mounted in a depression of a styro-foam piece in a mass culture chamber<sup>29)</sup> at 24.5°C and 70% R.H. It was occasionally opened up and its content was sieved through a mesh No. 200. The remainder on the mesh, as well as the powder passing the mesh, was carefully examined under binoculars to detect all the larval exuviae, especially the exuvial mandibles. In several cases the smallest exuvial mandibles detected did not appear to be those of the

\* The body sizes of the 1st and the early 2nd instar larva are almost identical. In our previous paper (IWATA and NISHIMOTO, 1981<sup>3)</sup>), the scale "5  $\mu$ " of the Fig. 2 (1st instar larva) should be read "50  $\mu$ ".

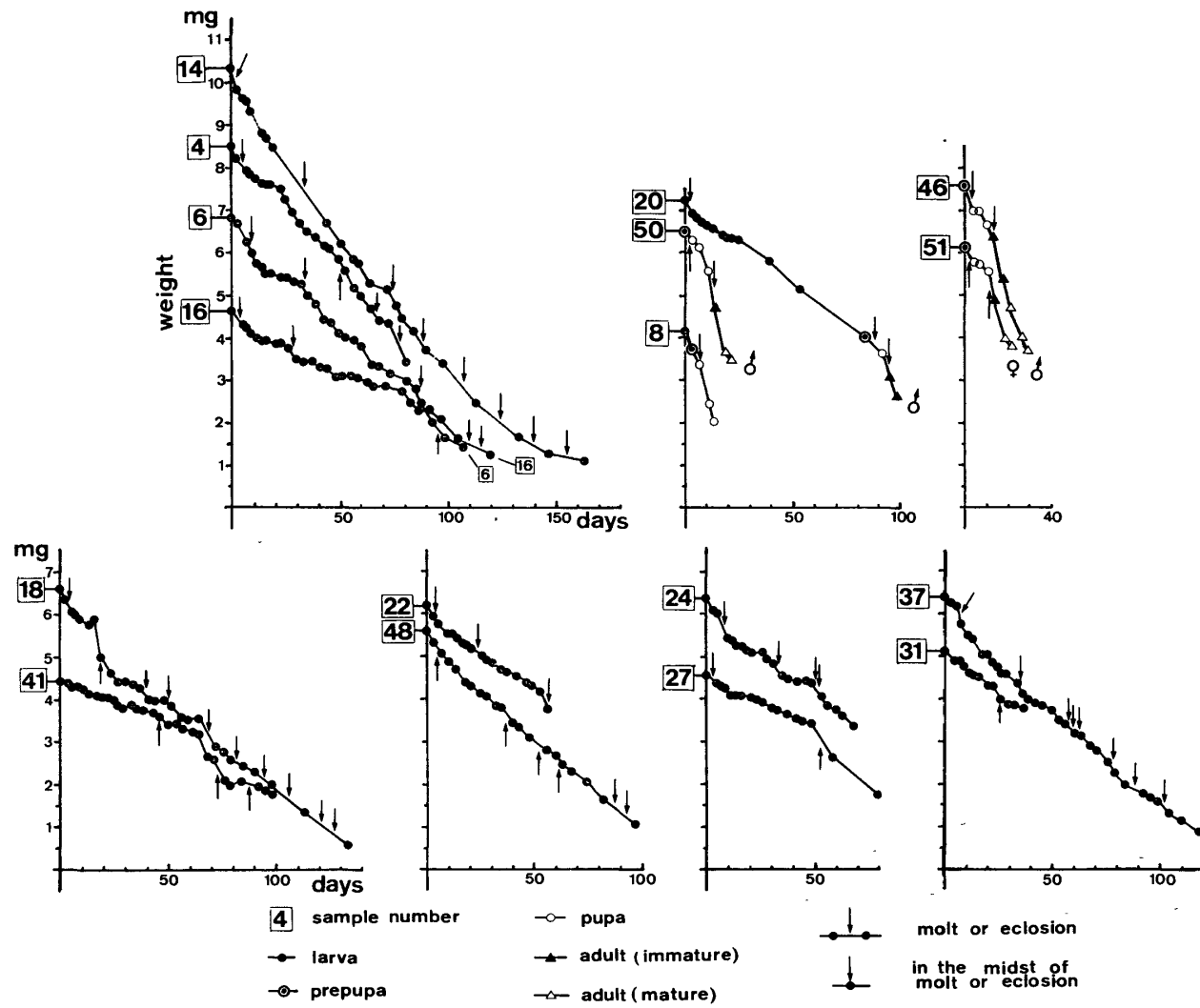

Fig. 3. Weight changes of larvae and the later developmental stages of *Lyctus brunneus* in the experiment with wood blocks. Abscissa represents the time in days after the supply of the larvae.

molt from 1st to 2nd instar because they were not so minute as were in most cases. In such cases the exuviae from 1st to 2nd instar were regarded as lost.

At every inspection insects were weighed with the chemical balance, and all the powder-state diet was renewed for the larvae. When a larva had metamorphosed to prepupa or the later stages, no powder was supplied to it.

#### 2.2.4. SEM observation

Several instar-known larvae were subjected to SEM observation in the same manner as before<sup>3)</sup>.

### 3. Results

#### 3.1. Experiment with wood blocks

Several examples of weight changes of the larvae and the later developmental stages are presented in Fig. 3. This wood block method was very unsuccessful in rearing larvae as demonstrated by their weight decrease. That might be due to the lack of support for boring and the poor nutritional condition of the wood substrate, and the subsequent starvation and death of the larvae occurred as briefly reported before<sup>3)</sup>. However, the individuals Nos. 8 and 20 were found exceptionally to succeed in pupation.

The result that most of the larvae molted supernumerarily presented a very interesting aspect. The maximum number of molts was 10 in individual No. 18. The heaviest larva (No. 14) molted 8 times until its death.

Additional experiments with prepupa (Nos. 46, 50 and 51) yielded successful pupation with a steep decrease in weight in the course of the metamorphoses. The pupal duration, as seen in Fig. 3, was 10–12 days in the present condition.

#### 3.2. Experiment with capsule and buckwheat flour

Of the 45 1st instar larvae employed, 20 individuals succeeded in pupation, 6

Table 1. Numbers of the larvae of *Lyctus brunneus* that succeeded in pupation in the "individual rearing method" with various instar numbers and various larval durations (males/females)

Instar number	Larval duration				Total
	40–60 days	60–100 days	100–140 days	More than 140 days	
4	5/1	0/1	1/0	0/0	6/2
5	0/0	1/2	0/4	0/0	1/6
6	0/0	2/0	0/2	0/0	2/2
7	0/0	1/0	0/0	0/0	1/0
More than 8	0/0	0/0	0/0	0/0 <sup>a)</sup>	0/0
Total	5/1	4/3	1/6	0/0	10/10

a) The individual No. 118 in the Fig. 4 (sex unknown) is possibly included here.

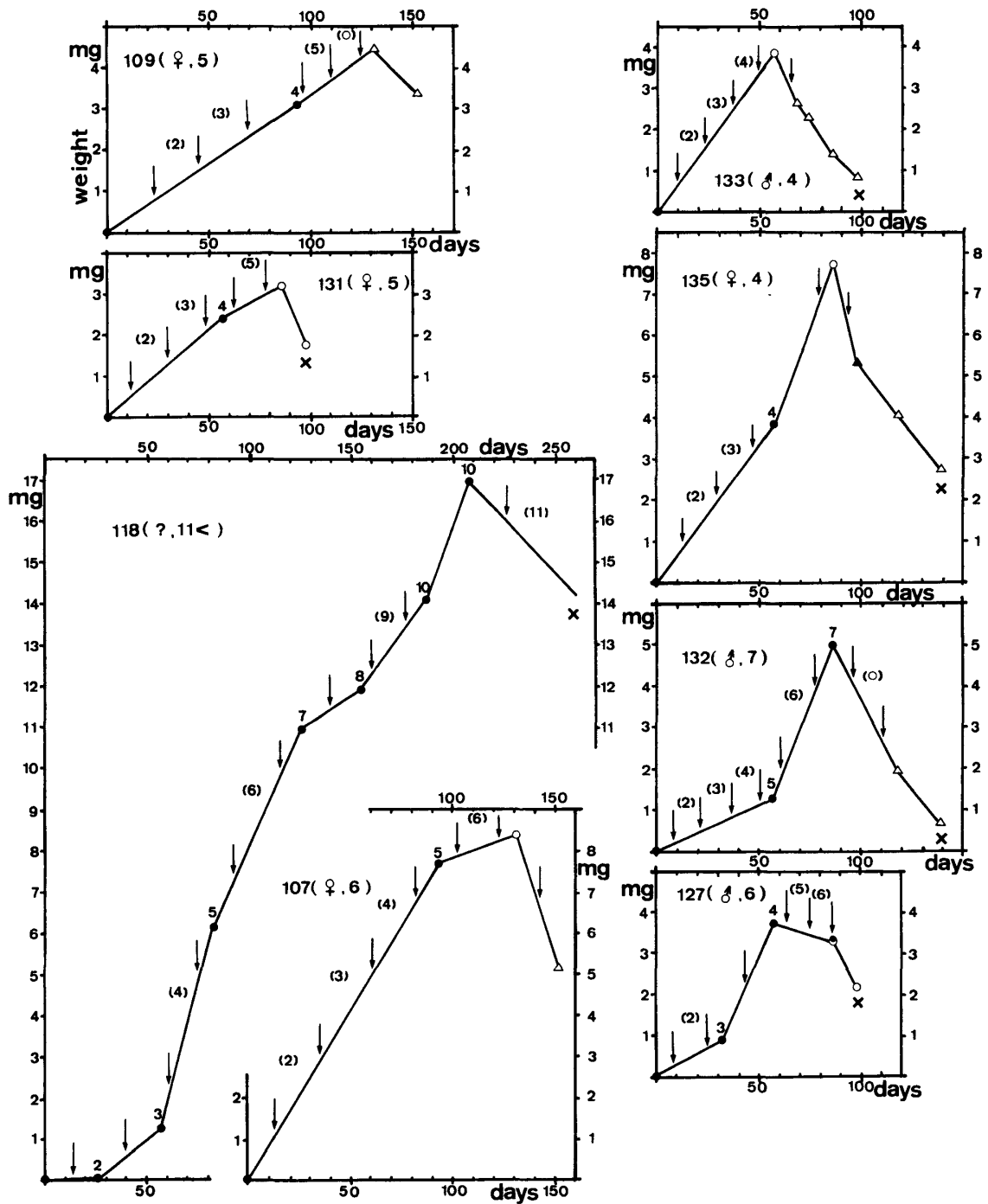

107 (♀, 6) : sample number with its sex and instar number  
 n : "n"th instar larva (n=2, 3, ..., 11)  
 ○ : pupa  
 ● : adult (immature)  
 ▲ : adult (mature)  
 X : dead  
 (3) : larval stage not inspected  
 (○) : pupa not inspected  
 ● : molt or eclosion  
 ○ : in the midst of pupation

Fig. 4. Several examples of the weight changes and metamorphoses of *Lyctus brunneus* reared with a capsule and buckwheat flour ("individual rearing method"). Abscissa represents the time in days after the collection and supply of the 1st instar larvae.



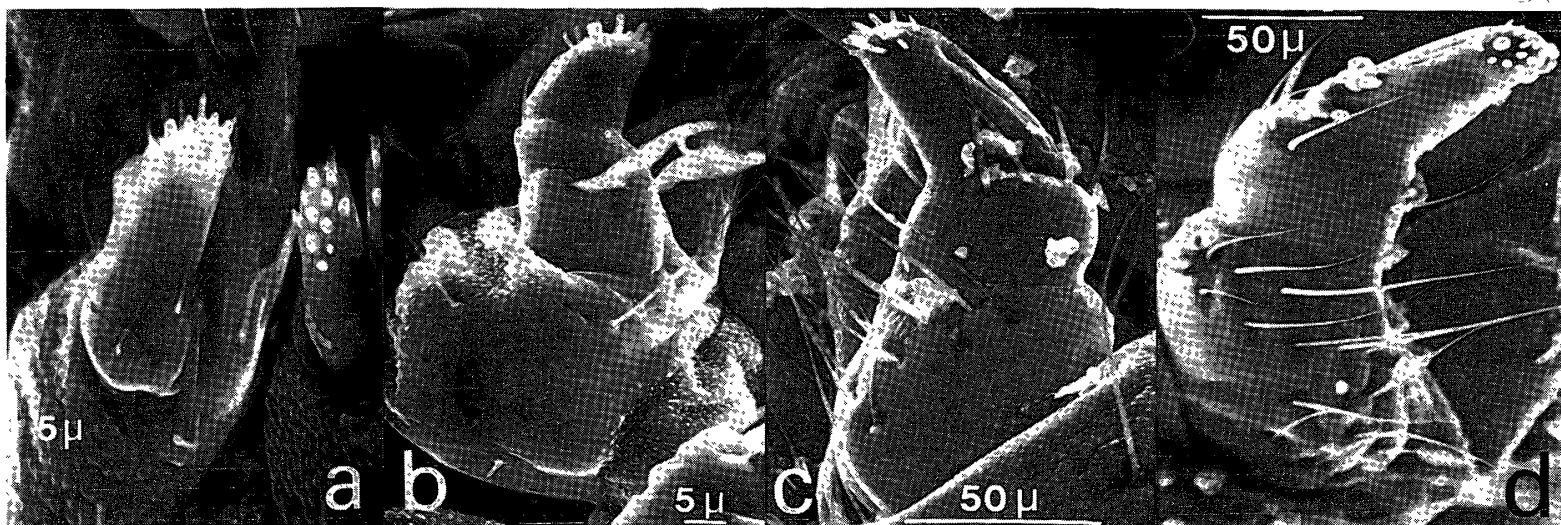

Fig. 5. Change of maxillary palpi in the course of larval development. a, 1st instar; b, 2nd instar; c, 4th instar; d, 5th instar.

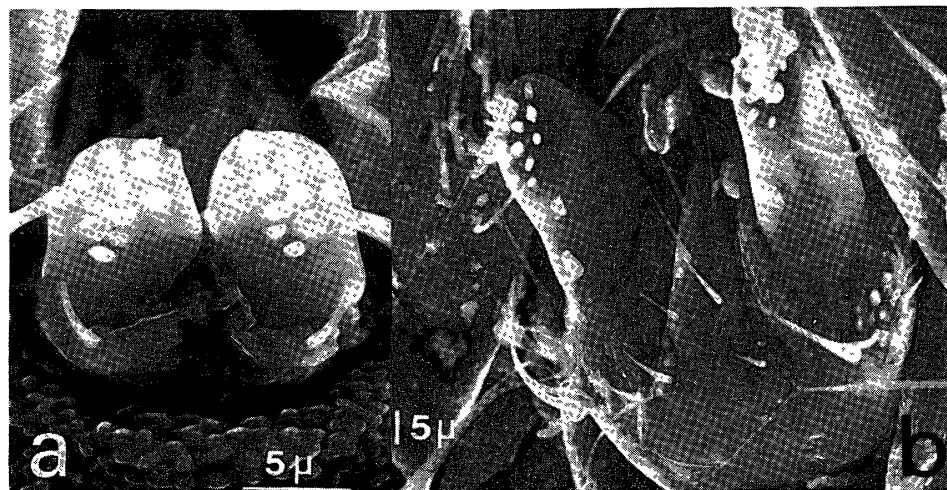

Fig. 6. Change of labial palpi in the course of larval development. a, 1st instar; b, 4th instar.

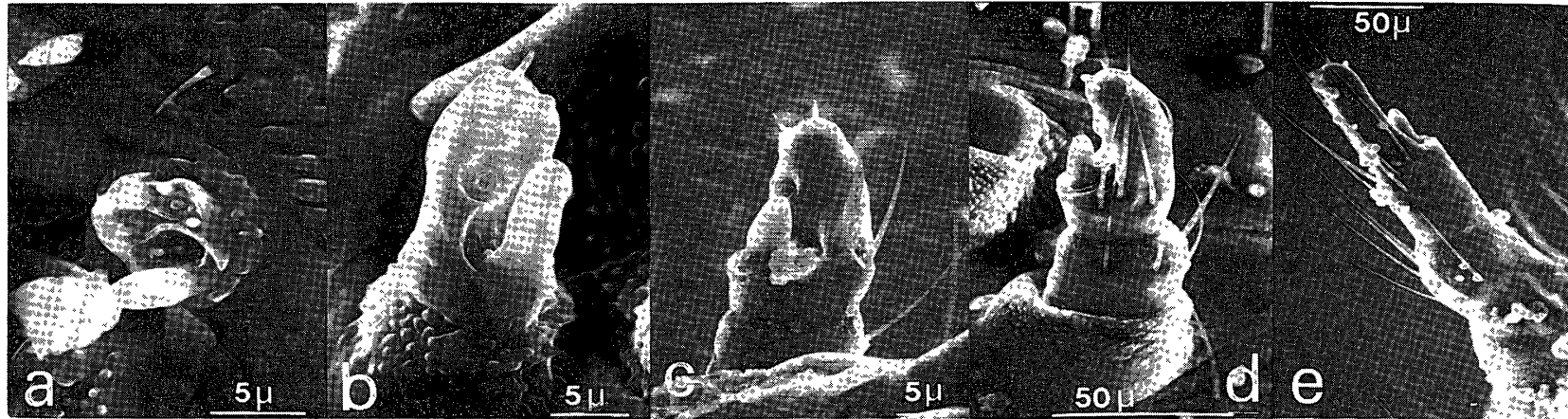

Fig. 7. Change of antennae in the course of larval development. a, 1st instar; b, 2nd instar; c, 3rd instar; d, 4th instar; e, 5th instar.

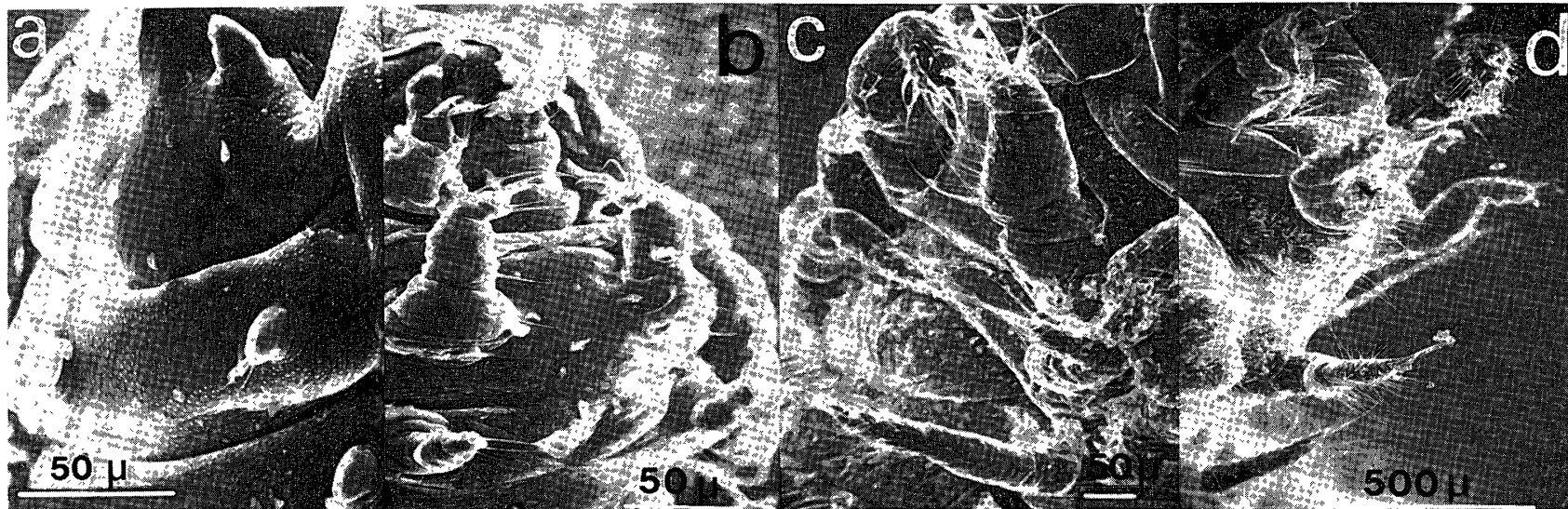

Fig. 8. Change of legs in the course of larval development. a, 1st instar; b, 2nd instar; c, 4th instar; d, 5th instar.

were victimized to SEM and other 19 individuals died before they pupated; about half of the larvae reared with this method succeeded in pupation. Table 1 summarizes the results with regard to the instar number and larval duration, where the larval duration was regarded as being as long as the period from the introduction of 1st instar larvae to the capsule up to the estimated pupation time. The pupation time was estimated from the information on the pupal duration as mentioned above. Figure 4 presents the metamorphoses and weight changes in several examples.

The number of larval instars between hatching and pupation generally ranged from 4 to 7 under the present condition, with an exception of the individual No. 118 having at least 11 instars. There seems to be a tendency of positive correlation between the instar number and the larval duration. Sexual difference of larval instar number was not clear insofar as the present results showed. In general, the variation of the larval instar number among individuals was observed.

### 3.3 SEM observation

The larva of *L. brunneus* naturally shows several morphological changes with succeeding instars. Of these, the changes of maxillary palpi (Fig. 5), labial palpi (Fig. 6), antennae (Fig. 7) and legs (Fig. 8) were shown by scanning electron microscopy (SEM) as it was comparatively facile to detect changings of these four parts. The maxillary and labial palpi became longer and more cylindrical in later instars as shown before<sup>3)</sup>, while the antennae and legs became comparatively longer and more slender in later stages; development of the appendices in general was usually observed. The fine changes of the larval antennal parts, as reported before<sup>3)</sup>, were confirmed again.

## 4. Discussion

From the results in Table 1 it can be thought that most of *Lyctus brunneus* larvae reared with the present method pass through 4–6 instars in the course of development. However, there was an exceptional case where the larva continued its growth up to the 11th instar as represented by the individual No. 118 in Fig. 4. Such an exception is not attributed to the variations of environmental and nutritional factors because the larvae were kept under constant and identical condition. Only hereditary or endocrinological factor would be its cause. Larval instar number tended to increase when the life cycle is prolonged, as is inferred from Table 1. The cause of this variation in life cycle duration is not known yet.

By general inference larvae designated as “middle instar” in our previous report<sup>3)</sup> are thought to correspond to the 3rd and 4th instar larvae if the final instar is 5th or 6th, or to the 3rd if the final is 4th.

Sexual difference in the larval instar number was not clearly observed in this species though KREYENBERG<sup>34)</sup> reported it in *Dermestes* in the order Coleoptera.

As seen in Fig. 3, if the larvae are placed in starving and/or exposed situation, they show "supernumerary molts" in response to the unfavorable conditions. Judging from the other results in Fig. 4, most of the larvae employed here (Fig. 3) undoubtedly had developed into 4th or the later instar(s) when they were heavier than 5 mg at the beginning of the test. The larva (No. 18 in Fig. 3) with the greatest number (10) of molts thus proved to have died at the time of at least the 14th instar. Supernumerary molts seem to occur more frequently and irregularly toward the death of the larva, as often occur in many other insect species. In contrast, the individual No. 118 in Fig. 4 shows that supernumerary molts may occur even under the nutritionally rich condition.

The larva of this species does not seem able to become the "prepupa", the final phase of the final instar larva, unless it is in "boring situation". On the other hand, prepupa can metamorphose very readily, as is seen in the cases of the individuals Nos. 46, 50 and 51 in Fig. 3. The "boring situation" or, in another term, the "tightness" seems prerequisite to "prepupation" (change into the prepupal form). Contrary to the case of this species, an anobiid, *Lasioderma serricornis* (FABRICIUS), belonging to Bostrychoidea as well, often makes a cocoon at pupation<sup>35</sup>, which may ensure the "tightness" for the larva to pupate and the subsequent sound emergence of the adult. This seems more advanced manner of pupation in comparison with *Lyctus*.

There were two exceptional cases with successful pupation of the larvae: No. 8 in Fig. 3, though not in the prepupal form, might be a full-grown larva in the course of "prepupation", and No. 20 seems a rare case where the larva happened to achieve the "boring situation".

As was stated before<sup>2)</sup>, the body weight of this species throughout the whole life cycle has its maximum in the stage of the full-grown larva or the prepupa. Molting is a factor of decreasing the body weight, as well as pupation, adult sclerotization, energy consumption and genital activities in this species. Results presented in Figs. 3 and 4 are compatible with these facts: larval molts cause weight decreases for a short time in the course of development, and the body weight always diminishes monotonously after the prepupal stage, as represented by the individuals Nos. 8, 20, 46, 50 and 51.

From the information obtained this time and before<sup>2)</sup> the gross weight change of this species throughout its life cycle is summarized schematically in Fig. 9, where the broken curves mean wide variations of molt number and growth rate according to the nutritional and environmental conditions. Under the condition of lower temperature and/or lower R.H., the broken part of the curve may become easier and longer, resulting in prolongation of life cycle duration<sup>33,36)</sup>. On the other hand, under the poorer nutritional condition, the curve may become easier, longer and more variable in length with greater and more variable number of moltings occurring, resulting in prolongation

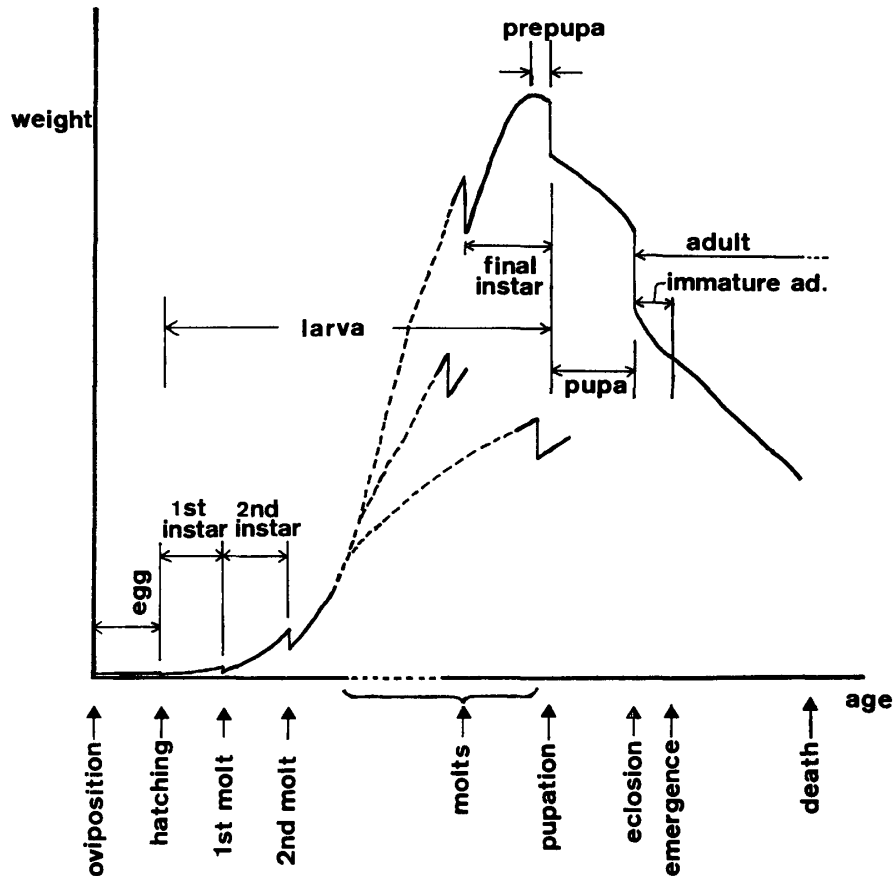

Fig. 9. Schematic diagram showing the weight change of *Lyctus brunneus* throughout the life cycle.

of life cycle duration as well. As was observed in other Coleoptera species<sup>34,37</sup>, shifting of molt number may well occur in this species when the temperature changes though the shifting of molt number in the present data seems to be related only to the variable life cycle duration at the same temperature. The hereditary, physiological, ecological, physical, and some other factors may also influence the larval growth and instar number to some extent, but most of them are beyond the scope of the present investigation.

Though the SEM observation showed several morphological changes in the course of larval development, they were not conspicuous enough between succeeding instars, especially in the later stages, to distinguish the larvae according to their instars. However, the 2nd instar larva seems rather stable in its morphology, and conveniently the characteristics of antennae (Fig. 7-b) would make it distinguishable from the 3rd instar.

Figure 8-d also shows a very distinct feature of the possible final instar larva, or the final stage of larval development, on its legs. This feature may be utilized in separating it from the penultimate stage, which is approximately identical with the

“ middle instar larva”<sup>3)</sup>.

Utilizing these morphological characteristics in selecting a certain stage or instar from a lot of larvae requires some kinds of optical devices with which to observe the fine morphology of living larvae without affecting them.

### 5. Conclusions

(1) A rearing method of the powder-post beetle, *L. brunneus*, with buckwheat flour and a small gelatin capsule enabled a single 1st instar larva to develop. It is also applicable to demonstrate the larval instar number by examining the number of exuviae.

(2) Under a good climate condition most of the larvae showed 3–5 molts before pupation, thus the final instar being 4th–6th though there were a few cases with more than 7 instars. The larval instar number seemed to be positively correlated with the larval duration.

(3) Larva shows supernumerary molts when placed in a poor nutrition or starvation condition. Once it had become a prepupa, it could pupate easily even without the support for boring.

(4) Though SEM revealed the larval fine morphological changes among the succeeding instars, their utilization for distinguishing instars still remains unavailable practically.

### References

- 1) J.E. CUMMINS and H.B. WILSON: J. Council Sci. Industr. Res. Austr., **9**, 37–56 (1936).
- 2) R. IWATA and K. NISHIMOTO: Mater. Organ., **17**, 51–66 (1982).
- 3) R. IWATA and K. NISHIMOTO: Kontyû, Tôkyô, **49**, 542–557 (1981).
- 4) A.M. ALTSON: Ann. Appl. Biol., **9**, 187–196 (1922).
- 5) A.G. BÖVING and F.C. CRAIGHEAD: Entom. Amer. (N.S.), **11**, 62–63, 288–291 (1930/1931).
- 6) T. KOJIMA: Ztschr. Angew. Entom., **19**, 325–356 (1932).
- 7) [V.] XAMBEU: Bull. Soc. Sci. Natur. Ouest Fr., Nantes, **8**, 69–72 (1898).
- 8) H.P. TSCHOLL: SAH Bull., Zürich, **3**(2), 20–32 (1975).
- 9) H.P. TSCHOLL: EMPA-Bericht, St. Gallen, (195), 1–108, Tab. 1–26, Abb. 1–46 (1977).
- 10) K. SUZUKI: Appl. Entom. Zool., **18**, 308–314 (1983).
- 11) K. SUZUKI: 17th IUFRO World Congr. (Japan, 1981), Proc. Div. 5, 404 (1981).
- 12) K. KOJIMA: Kôchi Daigaku Gakujutsu Kenkyû Hôkoku (Res. Rep. Kôchi Univ.), **3**(33), 1–6 (1954). (Japanese)
- 13) H. WATANABE and K. KOJIMA: Gensei, Kôchi, (8), 15–16 (1958). (Japanese)
- 14) K. KOJIMA, H. WATANABE and S. NAKAMURA: Nippon Ringakkaishi (J. Jap. Forestry Soc.), **41**, 175–177 (1959). (Japanese)
- 15) K. KOJIMA, H. WATANABE and S. NAKAMURA: *ibid.*, **42**, 18–21 (1960). (Japanese)
- 16) K. KOJIMA and H. WATANABE: *ibid.*, **42**, 359–362 (1960). (Japanese)
- 17) K. KOJIMA, H. WATANABE and S. NAKAMURA: *ibid.*, **43**, 245–250 (1961). (Japanese)
- 18) S. NAKAMURA, K. KOJIMA and M. YAMAOKA: Hiwa Kagaku Hakubutsukan Kenkyû Hôkoku (Misc. Rep. Hiwa Mus. Natur. Hist.), (5), 3–7 (1962). (Japanese)
- 19) M. YAMAOKA, K. KOJIMA and S. NAKAMURA: *ibid.*, (6), 26–29 (1963). (Japanese)

- 20) M. YAMAOKA, K. KOJIMA and S. NAKAMURA: *ibid.*, (7), 3-6 (1964). (Japanese)
- 21) S. NAKAMURA, K. KOJIMA and M. YAMAOKA: *ibid.*, (7), 7-10, pl. 1 (1964). (Japanese)
- 22) K. KOJIMA, H. WATANABE and S. KUNIYOSHI: *Nippon Ōyō Dōbutsu Konchū Gakkaishi* (Jap. J. Appl. Entom. Zool.), **8**, 76-78 (1964). (Japanese)
- 23) H. NAKASONE, K. KOJIMA and H. ICHIKI: *Ryūkyū Daigaku Nō-, Kasei-, Kō-gakubu Gakujutsu Hōkoku* (Sci. Bull. Div. Agric., Home Econ. and Engin., Univ. Ryukyus), (11), 121-127 (1964). (Japanese)
- 24) K. KOJIMA and K. KATAGIRI: *Nippon Ringakkaishi* (J. Jap. Forestry Soc.), **46**, 307-310 (1964). (Japanese)
- 25) K. KOJIMA, A. UCHIKOSHI and M. TERAŌ: *Gensei, Kōchi*, (15), 11-14 (1965). (Japanese)
- 26) K. KOJIMA, T. TATSUMI and A. UCHIKOSHI: *ibid.*, (18), 5-8 (1968). (Japanese)
- 27) K. MANSOUR and J.J. MANSOUR-BEK: *Biol. Rev.*, **9**, 363-382 (1934).
- 28) E.A. PARKIN: *Ann. Appl. Biol.*, **23**, 369-400, pl. 16 (1936).
- 29) R. IWATA and K. NISHIMOTO: *Mokuzai Kenkyū, Shiryō* (Wood Res. Technic. Notes), Kyōto, (15), 34-44 (1980). (Japanese)
- 30) R. IWATA and K. NISHIMOTO: *Mokuzai Gakkaishi* (J. Jap. Wood Res. Soc.), **29**, 336-343 (1983).
- 31) J.D. BLETCHLY: *Timber Technol.*, **68**, 29, 31 (1960).
- 32) R. IWATA and K. NISHIMOTO: *Kontyū, Tōkyō*, **50**, 10-22 (1982).
- 33) F.J. GAY: *Austr. J. Zool.*, **1**, 102-110 (1953).
- 34) J. KREYENBERG: *Ztschr. Angew. Entom.*, **14**, 140-188 (1929).
- 35) C. NIHO: *Iden (The Heredity), Tōkyō*, **37**, 69-71 (1983). (Japanese)
- 36) H. KÜHNE: *Proc. 4th Int'l. Biodeterior. Symp. (Berlin, 1978)*, 71-78, 367 (1980).
- 37) D. LUDWIG: *Ann. Entom. Soc. Amer.*, **49**, 12-15 (1956).