

Title	<Original>Permanent Fixation of Bending Deformation in Wood by Heat Treatment
Author(s)	NORIMOTO, Misato; OTA, Chiharu; AKITSU, Hiroshi; YAMADA, Tadashi
Citation	Wood research : bulletin of the Wood Research Institute Kyoto University (1993), 79: 23-33
Issue Date	1993-02-26
URL	http://hdl.handle.net/2433/53264
Right	
Type	Departmental Bulletin Paper
Textversion	publisher

Permanent Fixation of Bending Deformation in Wood by Heat Treatment

Misato NORIMOTO*¹, Chiharu OTA*²,
Hiroshi AKITSU*¹ and Tadashi YAMADA*²

(Received October 31, 1992)

Abstract—This article deals with the effect of heat on the fixation of bending set in wood. The wet specimen irradiated with microwave was bent around a form by using a metal strap. The bent specimen was oven-dried under restraint to fix its deformation, then heat-treated. The recovery tests by wetting, oven-drying and boiling for the bent specimens were conducted. With increasing heating temperature and time, the recovery of bending set diminished. There was an excellent linear relationship between the recovery of radius of curvature and the recovery of strain in the concave face. Almost complete fixation of set was achieved by the heat treatment above 30 hr. at 160°C and at around 12 hr. at 180°C.

Keywords: wood bending, drying set, heat treatment, fixation of deformation, recovery of set, microwave.

1. Introduction

Wood bending is an effective technique for bending wood where hygrothermal softening and drying set of wood are utilized. Bent wood has been widely used as various curved parts and members required for wood-made products such as furnitures, toys, musical instruments, barrels, etc. Among the several methods used to produce curved parts of wood, bending is the most economical of material and the most productive of members of high strength. However, the deformation is not stable and is recovered almost to its original state through re-moistening and heating. This recovery tendency of the bent wood has a practical consequence: both ends of the bent wood should be kept fixed to preserve the shape obtained after bending. If the bending deformation can be permanently fixed by appropriate treatments, the utilization of bent wood can be greatly expanded. Recently, it was reported that almost complete fixation of bent state could be achieved by the maleic acid-glycerol treatment of wood¹⁾. On the other hand, our previous studies indicated that almost complete fixation of compression set in wood could be achieved not only by either steaming²⁾ or heating^{2,3)} while under compression, but also by using water-soluble low molecular weights resins⁴⁾ that could be polymerized during the compression stage. The

*¹ Laboratory of Property Enhancement.

*² Fukui Institute of Technology, Fukui 910.

purpose of the study reported here was to investigate the permanent fixation of bending deformation in wood by heat treatment.

2. Experimental

Specimens of mizunara (*Quercus mongolica* Fisch var. *grosseserrata* Rehd. et Wils) wood, 40 by 2 by 1 cm (longitudinal by tangential by radial), were cut from heartwood portion of one log. After saturated with water, the specimens were boiled in water for an hour to remove growth stress remained in them. Then, they were cut to 34.5 cm length and dried at 105°C for 24 hr. in a dry oven. After cooling, lines were drawn on their surfaces at intervals of 10 cm from the central position to calculate the strains of the convex and concave faces as well as the radius of curvature of the bend.

A three-point bending test (span : 20 cm) of the specimens was conducted in the air-dried condition at room temperature . A sufficiently small load of 14.7 N within the elastic limit was applied to the specimen and its deflection was measured. The values of modulus of elasticity for the specimens were in the range from 3.65×10^2 to 10.33×10^2 MPa. The specimens having the values above 7.06×10^2 or below 3.87×10^2 MPa were excluded from the experiment.

After the specimens were dried at 105°C and cooled, the lengths between the lines were measured. Then, they were saturated through immersion in water. Microwave

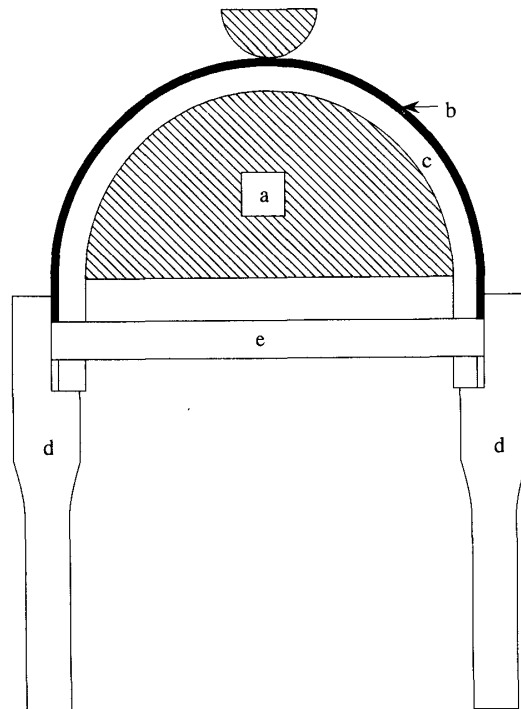

Fig. 1. The jig used for the bending operation.
a : wooden form, b : iron strap, c : wood specimen, d : wooden handle, e : metal piece.

irradiation (frequency 2.45 GHz, output power 500 W) was used to heat and soften the water-saturated specimen. A jig and a semi-circular wooden form shown in Fig. 1 were used for the bending operation. The jig was made of an iron strap (0.82 mm in thickness, 30 mm in width and 350 mm in length) with wood handles at both ends. The radius of the form was 65 mm. When a wood piece is bent, the convex side of the bend is stretched while the concave side is compressed. Softened wood can be compressed considerably, but it can be stretched very little. Accordingly, the failure will be governed by the tensile breaking strain and will occur mainly on the convex face. As a practical consequence, the objective in bending is to compress the wood while restraining the stretching along the convex side. This objective may be achieved by fixing the wood piece on a metal strap in such a way that the strap absorbs most of the tensile stress during the bending operation. By using such a device, most of the wood will be stressed in compression.

The water-saturated specimen was wrapped in a vinylidene chloride film. In addition to limiting the superficial temperature decrease due to water evaporation during the microwave irradiation, the film helps to keep the specimen hot and, at the same time, avoids metallic stain resulting from contact with the iron strap. After the microwave irradiation for 90 sec., hot water and vapor blew off from the transverse section of the specimen, so that it was assured that a drastic temperature increase of the specimen was induced. Our previous paper showed that temperature reached 90 to 110°C on the surface⁵⁾ and 100 to 130°C inside⁶⁾ the mizunara wood specimen after microwave irradiation for 1 to 3 min. The softened specimen was bent in one single operation around the form. Next, the bend was held in restraint by using a metal piece, and then separated from the jig after cooling. After the film was taken off, the bent specimen was dried at room temperature for 24 hr. using an electric fan, and then at 105°C so as to fix the deformation. Finally, the shape of the bend as well as the positions of the lines were traced on paper.

The bent specimens under restraint with a metal piece were heated in a dry oven at 140°C for 2, 4, 8, 16, or 64 hr., at 160°C for 2, 4, 8, 16, 32, or 64 hr., and at 180°C for 2, 4, 8, 16, or 32 hr. Three specimens at each heating condition were used. After the heat treatment, the metal piece holding the bent specimen to shape was removed, and then the shape of the bend as well as the positions of the lines were traced on paper. Then, the specimens were soaked in water until saturated and oven-dried at 105°C. This procedure was repeated four times. After the fourth cycle, the specimens were saturated in water, followed by boiling in water for an hour and drying at 105°C. At each stage, both the shape of the bend and the positions of the lines were traced on paper. Fig. 2 shows an example of the traced shape of the bend. The radius of curvature r , the length of the arc between the lines l and the surface strain ϵ of the bend were calculated by

$$r = \frac{(a^2 + b^2)}{2b} \quad (1)$$

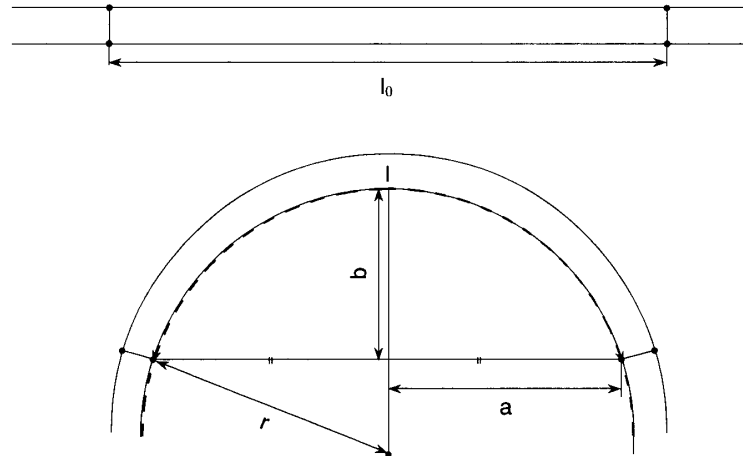

Fig. 2. An example of the traced shape of a bend.
The broken line is the arc calculated by equation (2).

$$l = 2r \sin^{-1} \left(\frac{a}{r} \right) \quad (2)$$

$$\epsilon (\%) = \frac{(l - l_0)}{l_0} \times 100 \quad (3)$$

where l_0 is the length between the lines before bending.

The broken line in Fig. 2 shows the arc calculated, which coincided well with the traced shape of the bend. Therefore, the radius of curvature and the strains of the bend were calculated using above equations.

3. Results and Discussin

The r value of the concave face for the untreated bend was 6.38 cm in the dry condition. Fig. 3 shows the changes in r of both the concave and convex faces after the wetting (W), ovdrying (D), and boiling (B) cyclic test. The value increased during the first three wetting and drying cycles, then remained almost unchanged at the forth cycle. But, the value increased again after boiling. The values of the concave and convex faces at the last drying reached 33.02 and 33.92 cm, respectively.

Figs. 4 to 6 show the results of the wetting, ovdrying, boiling cyclic tests for r of the concave face of the bend heated at 140, 160 and 180°C, respectively. The r values of the bends heated at 140°C for 2 hr. and at 180°C for 32 hr. were 6.42 and 6.43 cm at the initial dry state (D_0), respectively, which were almost the same values. In the treatment at 140°C for 2 hr. shown in Fig. 4, the recovery of set was remarkable and the r value at the last drying was slightly smaller than that of the untreated. With increasing treating time, the value decreased. For example, the values before and after the recovery test for the bend heated for 64 hr. were 6.43 and 10.33 cm, respectively. In the case of the treatment at 160°C shown in Fig. 5, the effect of the fixation of deformation occurred considerably even at 2 hr. With increasing treating time, the value decreased, especially above 16 hr. For example,

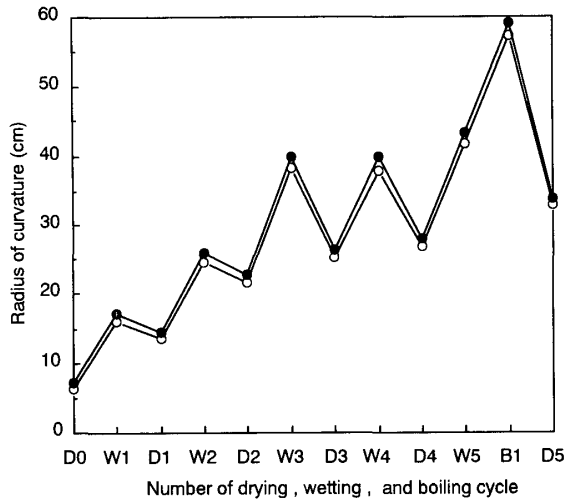

Fig. 3. The recovery of radius of curvature of the convex (●) and concave (○) faces for the untreated bend after the wetting (W), oven-drying (D) and boiling (B) test.

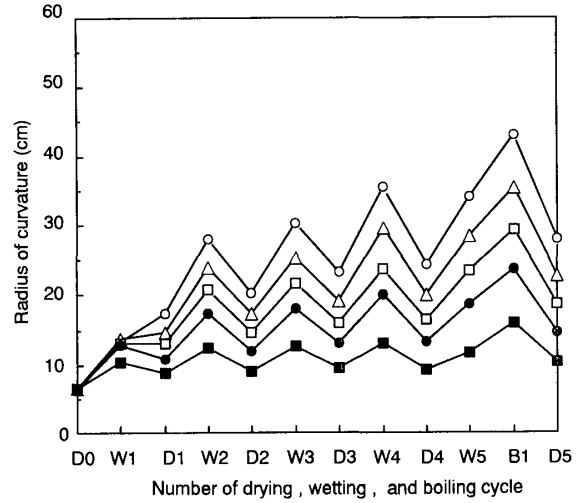

Fig. 4. The recovery of radius of curvature of the concave face for the bends treated at 140°C after wetting (W), oven-drying (D) and boiling (B) test. Treating time ○ : 2 hr, △ : 4 hr, □ : 8 hr, ● : 16 hr, ■ : 64 hr.

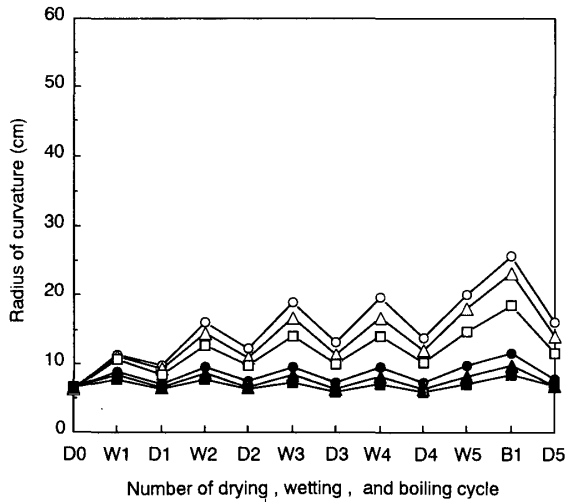

Fig. 5. The recovery of radius of curvature of the concave face for the bends treated at 160°C after wetting (W), oven-drying (D) and boiling (B) test. Treating time ○ : 2 hr, △ : 4 hr, □ : 8 hr, ● : 16 hr, ▲ : 32 hr, ■ : 64 hr.

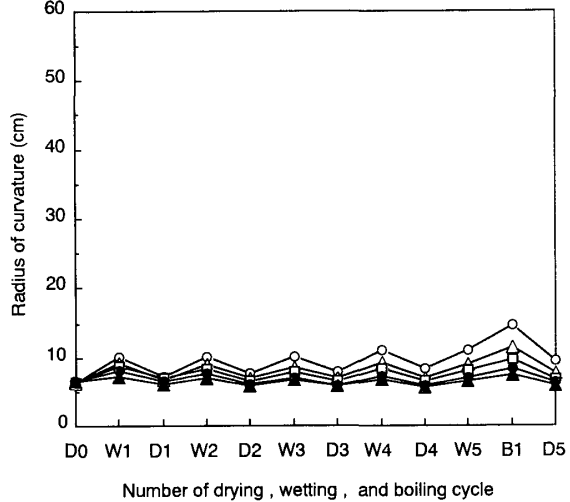

Fig. 6. The recovery of radius of curvature of the concave face for the bends treated at 180°C after wetting (W), oven-drying (D) and boiling (B) test. Treating time ○ : 2 hr, △ : 4 hr, □ : 8 hr, ● : 16 hr, ▲ : 32 hr.

the values at 64 hr. were 6.44 and 6.69 cm before and after the recovery test, respectively. In the case of the treatment at 180°C shown in Fig. 6, a remarkable effect of the fixation occurred at 2 hr. and the complete fixation was achieved between 8 and 16 hr.

For quantitative comparison of the fixation, the recovery of curvature of the bend is defined by

$$\text{Recovery of Curvature (\%)} = \frac{\Delta\rho}{\rho_0} \times 100 \quad (4)$$

where ρ_0 is the curvature before the recovery test and $\Delta\rho$ is the curvature difference before and after the recovery test. When the value is 100 %, complete recovery occurs, while when 0 %, complete fixation does. As the curvature after the recovery test can become smaller than that before the recovery test, the value can be a negative quantity. Fig. 7 shows the relationship between the recovery of curvature and the heating time at respective temperatures. The value of the recovery of curvature for the untreated bend was 81%. In the treatment at 140°C, the value decreased to about 40 % at 64 hr. In the treatment at 160°C, the value decreased drastically with increasing treating time and the deformation was almost fixed above 30 hr. In the treatment at 180°C, the deformation was completely fixed at about 12 hr. Above 12 hr. the value took the negative sign. Within 20 hr. at 140 and 160°C and within 10 hr. at 180°C, the recovery of curvature Y at time t could be represented approximately by an equation of the form

$$Y = Y_0 e^{-t/\tau} \quad (5)$$

where Y_0 is Y at $t=0$ and τ is the time at which Y becomes Y_0/e . When 41.2 hr. at 140°C, 10.5 hr. at 160°C or 3.11 hr. at 180°C as τ and 81% as Y_0 are substituted in the equation, respectively, the calculated Y values are shown by the solid lines in Fig. 7. If the fixation of deformation can be regarded as a rate process, the rate constant $k=1/\tau$ may be written in the form

$$k = \frac{1}{\tau} \propto e^{-E/RT} \quad (6)$$

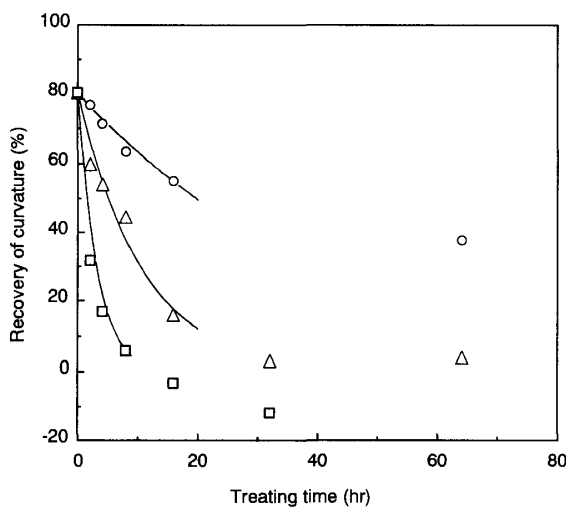

Fig. 7. The relationship between the recovery of curvature and the treating time at respective temperatures. The solid lines represent the values calculated by equation (5). ○: 140°C, △: 160°C, □: 180°C.

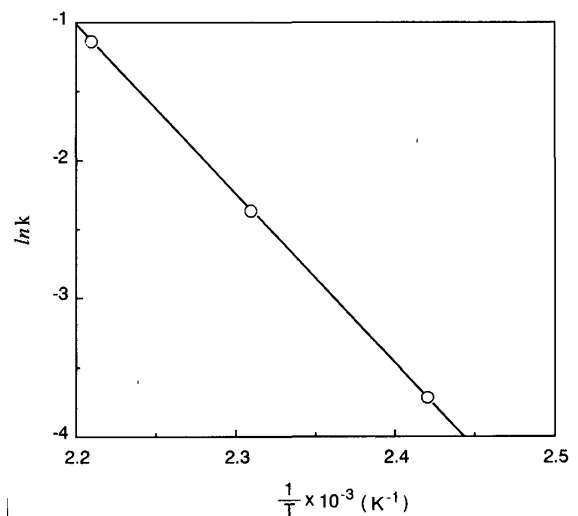

Fig. 8. The relationship between logarithm of the rate constant $\ln k$ and reciprocal of the absolute temperature $1/T$.

where $R(=1.986 \text{ cal/mol})$ is the gas constant, T is the absolute temperature and E is the apparent energy of activation. From this equation, $\ln k$ should be a linear function of $1/T$. The relationship between $\ln k$ and $1/T$ was expressed by a linear equation as shown in Fig. 8. The value of E calculated from the slope of the equation was about 24 kcal/mol. This value was comparable to the value of 23 kcal/mol obtained from the weight loss of wood by heat treatment below $200^\circ\text{C}^{7)}$. Thus, it may be speculated that the process between the two includes the same chemical changes in the cell wall constituents.

The ϵ values of the convex and concave faces in the longitudinal direction for the untreated bend in the dry condition after bending were 1.27 and -11.30% , respectively. Here, positive and negative signs represent tension and compression, respectively. The absolute value $|\epsilon|$ of the convex face is much smaller than that of the concave face. This is due to the fact that the end pressure to prevent tensile failure was applied in the bending operation by means of a metal strap which was placed against the convex face of the specimen. Although the $|\epsilon|$ values in the concave side were beyond 10%, any failures such as wrinkle and lateral buckling did not occur. Fig. 9 shows the changes in ϵ of the convex and concave faces for the untreated bend by the drying, wetting and boiling cyclic tests. The tensile strain decreased gradually without going up and down. On the other hand, the compressive strain tended to disappear with increasing in wetting and with decreasing in drying. The values of the residual strains of the concave and convex faces were -2.36 and 0.12% , respectively.

Figs. 10 to 12 represent the changes in ϵ of the bends heated at 140, 160 and 180°C ,

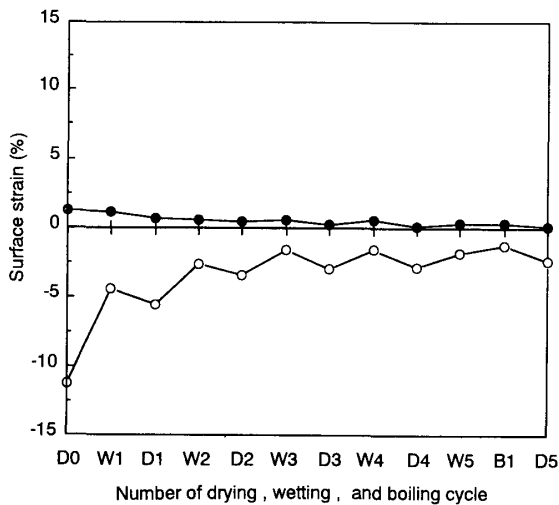

Fig. 9. The recovery of the strains of the convex (●) and concave (○) faces for the untreated bend after the wetting (W), overdrying (D) and boiling (B) test.

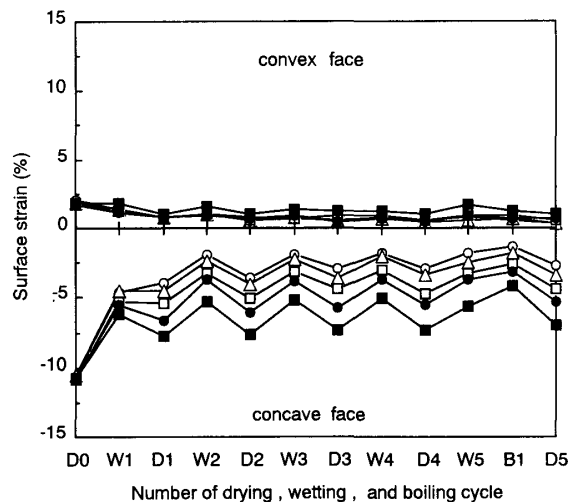

Fig. 10. The recovery of strain of the convex and concave faces for the bends treated at 140°C after wetting (W), overdrying (D) and boiling (B) test. Treating time ○ : 2 hr, △ : 4 hr, □ : 8 hr, ● : 16 hr, ■ : 64 hr.

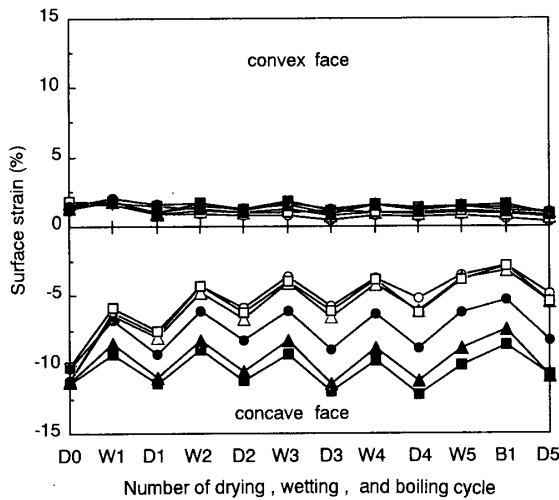

Fig. 11. The recovery of strain of the convex and concave faces for the bends treated at 160°C after wetting (W), ovendrying (D) and boiling (B) test. Treating time ○ : 2 hr, △ : 4 hr, □ : 8 hr, ● : 16 hr, ▲ : 32 hr, ■ : 64 hr.

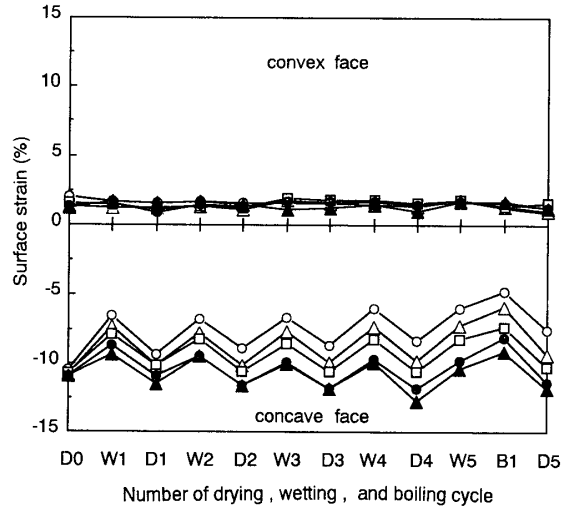

Fig. 12. The recovery of strain of the convex and concave faces for the bends treated at 180°C after wetting (W), ovendrying (D) and boiling (B) test. Treating time ○ : 2 hr, △ : 4 hr, □ : 8 hr, ● : 16 hr, ▲ : 32 hr.

respectively. The ϵ values of the convex and concave faces after bending were 1 to 2 % and -10 to -11 %, irrespective of heating temperature and time, respectively. Generally, the $|\epsilon|$ values of both the faces became small with increasing temperature and time. In some treatments at 160 and 180°C, the ϵ value of the concave face in the drying stage of the recovery test became smaller than that before the recovery test. This is attributed to the fact that a part of hemicelluloses degraded by heat treatment was removed from the specimen in the wetting stage of the recovery test and the cell walls shrank largely in the successive drying stage.

The recovery of strain was defined by

$$\text{Recovery of Strain (\%)} = \frac{\Delta\epsilon}{|\epsilon_0|} \times 100 \quad (7)$$

where ϵ_0 is the strain before the recovery test and $\Delta\epsilon$ is the difference in the absolute values of the strains before and after the recovery test.

Fig. 13 and 14 show the relationships between the recovery of strain of the convex and concave faces and the time at respective temperatures. The recovery of strain of the untreated bend was about 91% in the convex face and about 79% in the concave face. With increasing temperature and time, both the recovery of strain decreased. The recovery of the convex face was larger than that of the concave face within the time examined at 140 and 160°C. When compared the results in Fig. 7 with those in Fig. 13 and 14, the recovery of curvature corresponded well to the recovery of strain of the concave face. Fig. 15 shows the relationship between the recovery of curvature and the recovery of strain of the concave

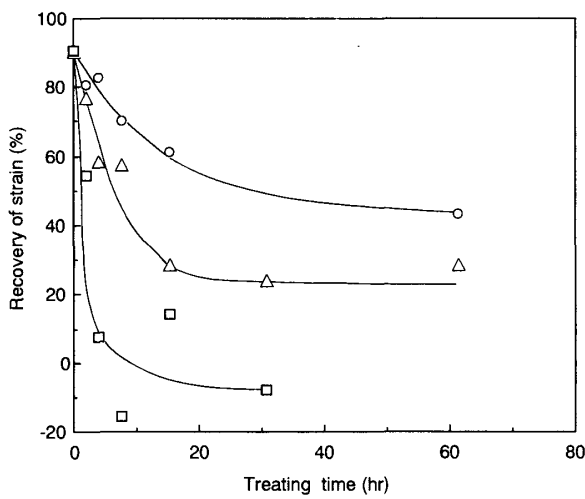

Fig. 13. The relationship between the recovery of strain of the convex face and the treating time at respective temperatures.
 ○ : 140°C, △ : 160°C, □ : 180°C.

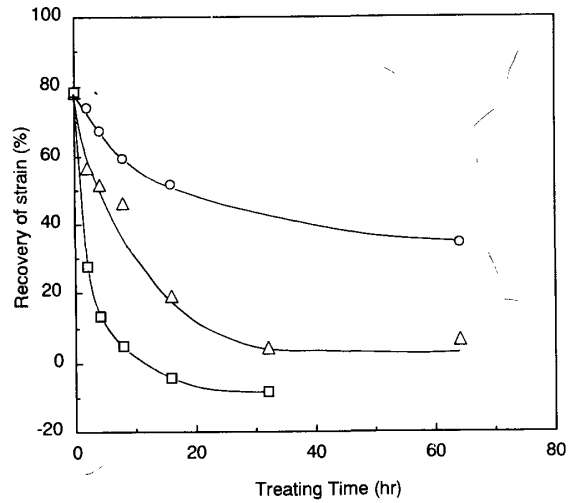

Fig. 14. The relationship between the recovery of strain of the concave face and the treating time at respective temperatures.
 ○ : 140°C, △ : 160°C, □ : 180°C.

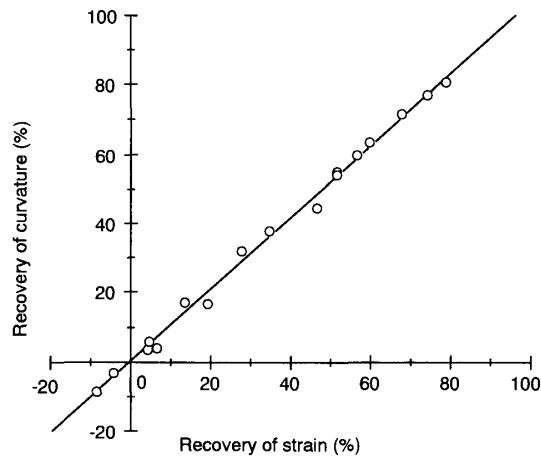

Fig. 15. The relationship between the recovery of curvature and recovery of strain of the concave face.

face. The regression line was represented by a following linear equation.

$$y = 1.04x + 0.17 \quad (8)$$

where y is the recovery of curvature and x is the recovery of strain of the concave face. The correlation coefficient of the regression line was 0.998.

In discussing the mechanism of the heat fixation of bending deformation, it is important to clarify the relationship between the changes in chemical constituents of the cell wall and the heating temperature and time. In the treatment of cellulose below 180°C, β -cellulose decreases, while α - and γ -celluloses increase⁸⁾. This results show that β -cellulose changes partly to α -cellulose by polymerization and partly to γ -cellulose by decomposition. The

same reaction may also occur in hemicelluloses. On the other hand, the results on X-ray diffraction of wood treated in the temperature range from 100 to 250°C showed an increase in crystallinity in the early stage of the treatment⁹⁾. The results of IR-spectra in the short time treatment of wood below 180°C showed no occurrence of COO and C=O bands due to degradation of the constituents⁸⁾. On the other hand, in the long time treatment below 180°C, the changes in wood color due to degradation of the constituents are recognized. The results on chemical analysis of oak wood⁸⁾ treated at 150 and 180°C for 24 hr. showed that α -cellulose, hemicelluloses and pentosan decreased from 40.5 to 38.9 and 29.2%, from 23.3 to 14.4 and 13.6% and from 17.5 to 15.0 and 4.9%, respectively. Furthermore, the results on chemical analysis of beech wood⁸⁾ treated at 160°C for 1 to 2 days showed that considerable decreases in the constituents, especially in pentosan and lignin, were recognized.

As stated in the previous papers^{10,11)}, the mechanism of drying set can be considered as follows. The cell wall is a fiber-reinforced composite with a complex multi-layered structure. In each layer, cellulose molecules are grouped together in long filaments called microfibrils, separated by a matrix containing hemicelluloses and lignin. Both moisture and temperature act differently on matrix and microfibrils. The elevation of temperature in the wet condition softens the matrix, and its two main constituents, hemicelluloses and lignin, shift from the glassy state to something near the rubbery state. On the other hand, cellulosic microfibrils because of the crystalline nature remain in the glassy state and are almost unaffected by moisture and heat. When a load is applied to the material, most of it is supported by the microfibrils at the local level. Softening of the matrix enables the relative displacement of the microfibrils in order that their whole framework deforms elastically to adjust to the local loading. As lignin is a slightly cross-linked high polymer, its deformation should be viewed as increased viscoelastic strain rather than plastic flow. The departure of the water molecules due to drying induces the reformation of hydrogen bonds between the molecules of the matrix constituents. Together with the temperature decrease, this process leads to the return to the glassy state, where the elastic deformation of the microfibrils and the matrix are frozen. Accordingly, the set will not be recovered provided no re-softening of the matrix occur. However, as soon as the matrix is softened again through re-moistening and heating, most of the set is recovered due to the libration of the energy-elastic strain stored in the microfibrils and the entropy-elastic molecular movements in the matrix.

Taking account of the mechanism on drying set mentioned above, any of the following three mechanisms is considered to be essential to fix it permanently.

- 1) The formation of cross-linkages between molecules of the matrix constituents to prevent the relative displacement of microfibrils.
- 2) The relaxation of the stresses stored in the microfibrils and the matrix.
- 3) The formation of the polymers inaccessible to water from hydrophilic cell wall

constituents, especially hemicelluloses, to prevent their re-softening by moisture and heat.

Hemicelluloses, cellulose in non-crystalline region, and probably even lignin degrade in the temperature range from 140 to 180°C, so that the network-structure may be loosened. Consequently, the stresses stored in the matrix and the microfibrils may be released. At the same time, cross-linking reactions may also be possible, which is speculated from the increases in crystallinity and modulus of elasticity⁹⁾ of wood. The formation of cross-linkages acts to fix the deformation. However, this cross-linking reaction accompanied by heat treatment is now disproved¹²⁾. On the other hand, the hygroscopicity of wood decreases, which is considered to result in the formation of furfural polymers from hemicelluloses¹²⁾. It is believed that the dimensional stabilization with heat results from these structural changes in hemicelluloses. From these results, it seems reasonable to suppose that the fixation of bending deformation by heat results mostly from the release of the stresses stored in the microfibrils and the matrix as well as the decrease in the hygroscopicity of wood.

References

- 1) H. FUJIMOTO, T. ANAZAWA and K. YAMAGISHI : *Proc. Internatl. Symposium on Chemical Modification of Wood*, Kyoto, Japan, 83–91 (1991).
- 2) M. INOUE *et al.* : *Wood and Fiber Sci.*, in press.
- 3) M. INOUE and M. NORIMOTO : *Wood Research and Technical Notes*, No.27, 31–40 (1991).
- 4) M. INOUE *et al.* : *Mokuzai Gakkaishi*, **37**, 227–233 (1991).
- 5) M. MORI, M. NORIMOTO and Y. WAKITA : *Wood Industry*, **38**, 229–234 (1983).
- 6) M. MORI *et al.* : *Wood Industry*, **39**, 600–603 (1984).
- 7) A. KURIYAMA : *J. Soc. Material Sci., Japan*, **16**, 772–776 (1967).
- 8) H. IMAMURA *et al.* : “Chemistry of Wood Utilization”, Kyoritsu Shuppan, 23–40 (1983).
- 9) N. HIRAI, N. SOBUE and I. ASANO : *Mokuzai Gakkaishi*, **18**, 535–542 (1972).
- 10) M. NORIMOTO and J. GRIL : *J. Microwave Power and Electromagnetic Energy*, **24**, 203–212 (1989).
- 11) M. NORIMOTO : *Chemical Education*, **39**, 170–174 (1991).
- 12) A. J. STAMM : “Wood & Cellulose Science”, The Ronald Press Company, 317–320 (1964).