

Title	<Note>Observation of Feeding Behavior of Termite Using CCD Camera and Its Relation to the Generation of Acoustic Emission (AE)
Author(s)	FUJII, Yoshihisa; IMAMURA, Yuji; YOSHIMURA, Tsuyoshi
Citation	Wood research : bulletin of the Wood Research Institute Kyoto University (1995), 82: 47-53
Issue Date	1995-09-30
URL	http://hdl.handle.net/2433/53233
Right	
Type	Departmental Bulletin Paper
Textversion	publisher

Observation of Feeding Behavior of Termite Using CCD Camera and Its Relation to the Generation of Acoustic Emission (AE)*¹

Yoshihisa FUJII*², Yuji IMAMURA*³
and Tsuyoshi YOSHIMURA*⁴

(Received May 31, 1995)

Abstract—The feeding behavior of a worker of *Coptotermes formosanus* Shiraki was observed with CCD camera under AE monitoring. Two types of feeding behavior, biting and nibbling using the mandible, were observed. AEs were detected only when the termites bited or nibbled at the wood surface.

Keywords: termite, feeding behavior, CCD camera, acoustic emission

1. Introduction

Non-destructive detection of termite activities in wood is a technique of great importance to protect wooden houses from attacking of termite and keep them safe. Although the realization of the technique has been long desired, no method has been ever developed of real feasibility for the detection and of practical use.

Fujii *et al.* have clarified experimentally the feasibility of acoustic emission (AE) monitoring for detecting the feeding activity of workers of *Coptotermes formosanus* Shiraki¹. This feasibility was also supported by the following studies^{2,3}. Noguchi *et al.* confirmed the feasibility in the AE monitoring tests using wooden posts and commercial dimensions³. Recently AE monitoring apparatus for commercial uses to detect termite activities in wood were developed^{4,5}. In these studies it was clarified, AEs were detected from the wood inhabited by workers, no AEs were detected from the wood inhabited only by soldiers, more AEs generate according to the number of workers inhabited, the more AEs of large amplitude were detected, the nearer to the inhabiting area the AE sensor was positioned, and so on.

These studies resulted in the conclusion from some points of view, that the AE

*¹ This work was mainly conducted at Wood Research Institute, and presented at the 43rd Annual Meeting of Japan Wood Research Society in Iwate, August, 1993.

*² Laboratory of Woodworking Machinery, Department of Wood Science and Technology, Faculty of Agriculture, Kyoto University.

*³ Laboratory of Wood Composite.

*⁴ Laboratory of Deterioration Control.

generation in the wood inhabited by termites could be attributed to the micro fracture at the site of attacking by the workers. Imamura *et al.* have investigated the feeding behavior of the Japanese economically important rhinotermitids, *Coptotermes formosanus* Shiraki and *Reticulitermes speratus* Kolbe by AE monitoring and clarified not only the cyclic changes of the feeding activities, but also its relations to the wood species fed, the temperature change and the disturbances of light scattering or vibration^{6,7}.

However, no one has ever described the relationships between the feeding behavior and the AE generation directly, or the mechanism of AE generation due to the feeding behavior. In this experiment, the feeding behavior of a worker was observed directly using CCD camera under AE monitoring, and the relationships between the feeding behavior, and the AE generation, and the mechanism of AE generation were discussed.

2. Materials and Methods

The experimental set-up used is shown in both Figures 1 and 2.

2.1 CCD camera

For the observation of the feeding behavior of the termite, a small color CCD (Charge Coupled Device) camera (ELMO, MN401) was employed. The picture of about 768×494 pixels taken by the CCD device (half inch in nominal size) through an optical lens of 17 mm in diameter, a focal distance 7.5 mm and an aperture value 1:1.6 were transferred to CRT

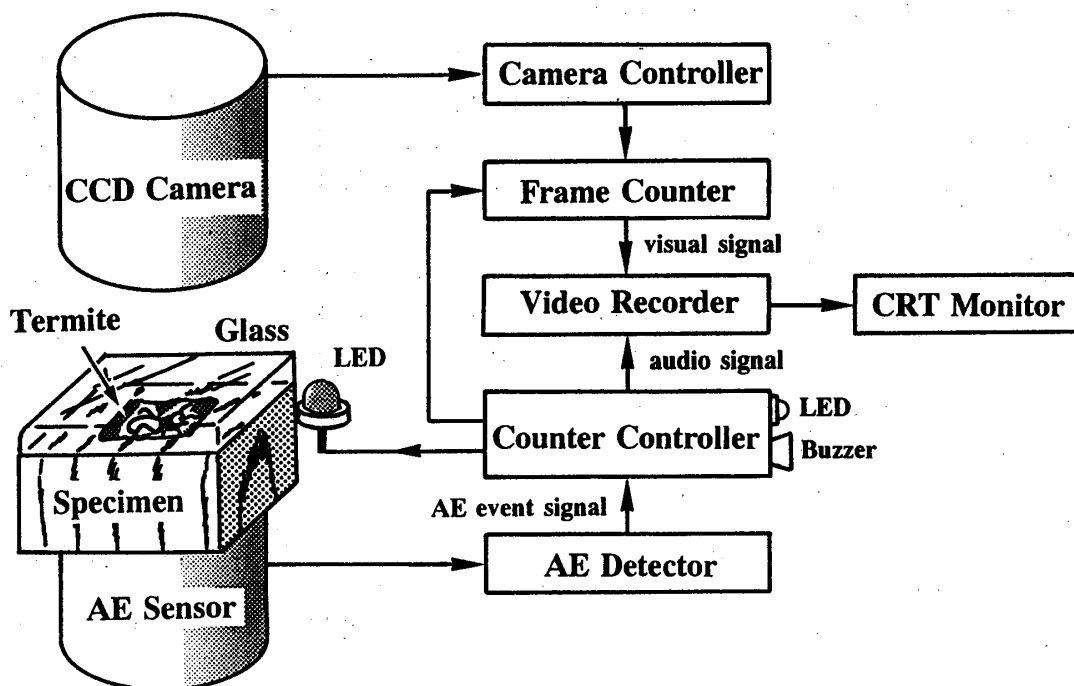

Fig. 1. Schema of the experimental set-up.

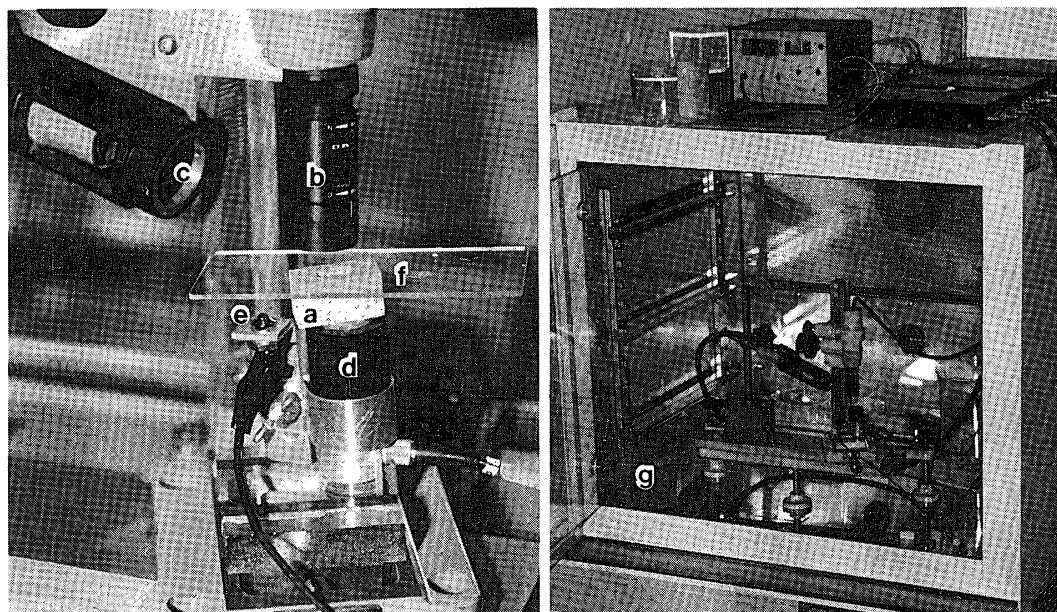

Fig. 2. Observation of feeding behavior of termite.
a: Wood specimen loaded by a worker, b: CCD camera head, c: Lighting, d: AE sensor, e: LED, f: Glass, g: Air-conditioned chamber.

monitor and recorded with a video recorder.

2.2 Termite and wood specimen

A rectangular hole of about 3 mm wide, 6 mm long and 3 mm deep was made in a longitudinal surface of an air-dried small specimen of western hemlock (*Thuja heterophylla* Sarg.) of 10 mm by 10 mm in square and 20 mm long in the longitudinal direction. A worker of *Coptotermes formosanus* Shiraki was loaded in the hole and the hole was covered with transparent glass. Both the specimen and the camera head together with a lighting apparatus made of optical fibers were put in a dark chamber whose temperature was conditioned at 27°C.

2.3 AE Monitoring

A piezoelectric AE sensor of resonant frequency 140 kHz (NF, AE-901U) was attached on the opposite surface to the hole with hot-melt adhesive. The signal from the sensor was amplified by about 66 dB, filtered by a high-pass filter of cut-off frequency 100 kHz and discriminated at a threshold voltage of 0.1 V with the AE apparatus (NF, AE-9501).

2.4 Recording of AE generation on the picture

Using a “frame counter”, two kinds of number can be overlapped on the picture taken by the camera as shown in the upper left corner of the monitored picture in Figure 4. The later number of five figures denotes the frame number of the video apparatus that increases every one-sixtieth second automatically. The former number of two figures denotes the

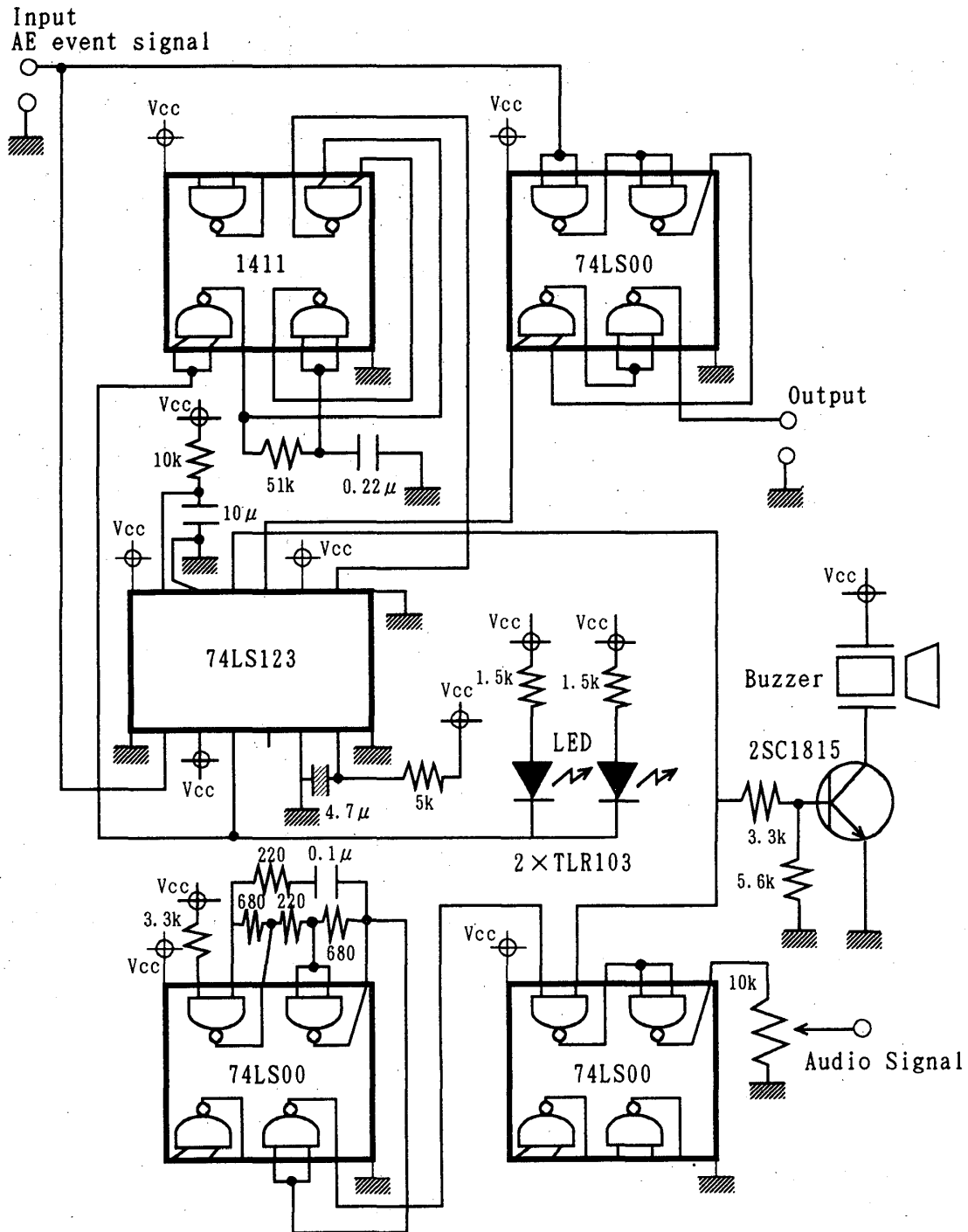

Fig. 3. Schema of counter controller.

“scene number” which increases at each resetting of the frame number. Using an another “counter controller” (Figure 3), these numbers are so controlled that frame counter should be reset by the AE event signal (TTL negative logic) from the AE-9501, and restarts counting just after the resetting. With this function of the counter controller, the scene

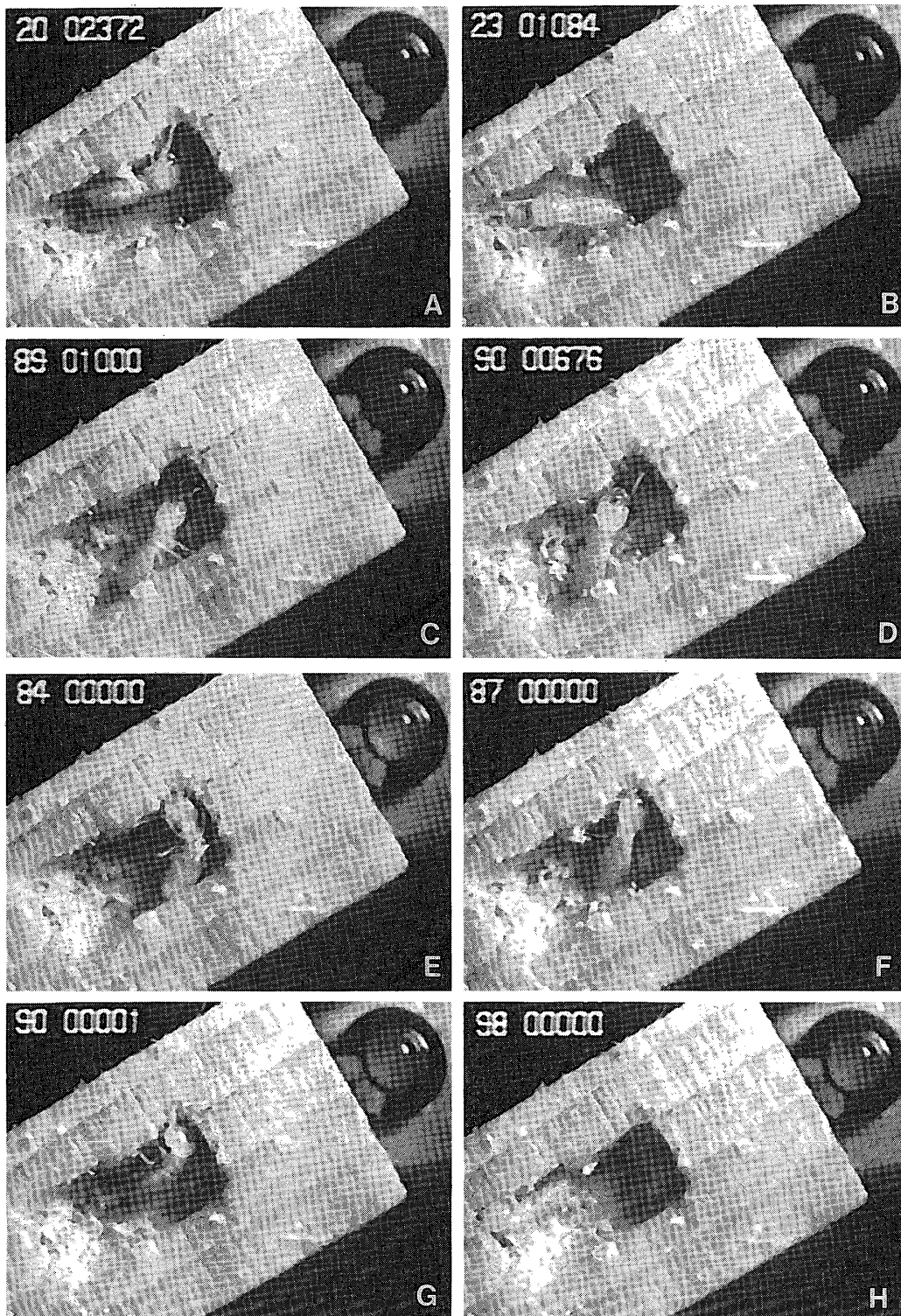

Fig. 4. Feeding behavior of termite observed. The upper four pictures (A–D) are scenes when no feeding behavior was observed, nor AE was detected. The lower four (E–H) are scenes when the termite bites or nibbles the wood surface generating AEs. The LED blinks and the number is reset at the moment that AE generates.

number in the picture increases according to the AE generation and the time (the number of video frames run) between two successive AE events can be recorded. In addition a small LED and a buzzer controlled also by the counter controller were employed, which trinkled and beeped, respectively according to the AE generation. The beep signal was sent to the video recorder. The LED was set near the specimen so that both of them came into same pictures. By the functions both of LED and buzzer, the AE generation was recorded visually and audibly on the video system.

Results and Discussions

The behavior of the termite (worker) was observed and recorded for about two hours after it was loaded in the hole. This observation was repeated several times. During the experiment, the termite was exposed to the light, which was just intensive enough to take pictures. For about an hour from the start of the observation, the termite was just moving around inside the hole, touching sometimes the wood surface with its antennae. No AE event was recorded during this period. The upper four pictures in Figure 4 (A-D) show the example snapshots printed by a video printer from the record during this period.

After that, the termite began to bite or nibble at the wood surface repeatedly with its mandible, and according to this feeding activity AE was detected interruptedly. Two types of the feeding behaviors were observed. The one is that the termite bites the wood sticking its mandible deep into the wood (Fig. 4 E). Being anchored to the wood at its mandible, the termite sometimes bowed or twisted its body trying to pull the mandible out. The other is that the termite nibbles the wood surface rubbing its head on the wood surface (Fig. 4 F-H). More AE events due to the nibbling were detected, however the monitoring of AE waves by an oscilloscope showed that AEs due to the biting were sometimes of larger amplitude than those of nibbling. The lower four snapshots in Figure 4 showed the feeding behavior of the termite, appearing also the frame number was reset to "00000" and the LED turned on at the time when AE generated due to the feeding behavior. It was confirmed that AEs were detected only when the termites bited or nibbled at the wood.

Due to the limited ability of the optical systems, it was unable in this experiment to take pictures of more magnification. However, the AEs detected from the wood infested by the termites could be attributed to the feeding behavior of the termite, such as biting or nibbling at the wood in this investigation.

The study using direct observation of the termite behavior under AE monitoring is still in the beginning stage, that it would give us in the near future more detailed and useful information not only about the relationships between the behavior of the termite and the AE generation, but also about the mechanism and the characteristics of AEs generated due to the micro fracture in wood.

Acknowledgements

This work was supported in part by a Grant-in-Aid from the Ministry of Education, Science and Culture of Japan (No. 04660188-1993).

References

- 1) Y. FUJII, M. NOGUCHI, Y. IMAMURA and M. TOKORO: *For. Prod. J.*, **40**(1), 34–36 (1990).
- 2) V.R. LEWIS, R.L. LEMASTER, F.C. BEALL and D.L. WOOD: *The Int. Res. Group on Wood Preserv.* Document No. IRG/WP/2375 (1991).
- 3) M. NOGUCHI, Y. FUJII, M. OWADA, Y. IMAMURA and M. TOKORO: *For. Prod. J.*, **41**(9), 32–36 (1990).
- 4) M. NOGUCHI, M. OWADA, Y. IMAMURA, Y. SAWADA, Y. FUJII and M. TOKORO: 22nd Annual Meeting of the Int. Res. Group of Wood Preserv. (Poster) (1991).
- 5) R.H. SHEFFRAIN, W.P. ROBBIMS, P.B. NAN-YAO SU and R.K. MUELLER: *J. Econ. Entomol.*, **86**(6), 1720–1729 (1993).
- 6) Y. IMAMURA, M. TOKORO, M. OWADA, Y. FUJII and M. NOGUCHI: *The Int. Res. Group on Wood Preserv.* Document No. IRG/WP/1514 (1991).
- 7) Y. IMAMURA and Y. FUJII: *Wood Preservation*, **21**(2), 11–19 (1995).