

Title	Studies on Speech Perception by Multiple Cochlear Implant.
Author(s)	Ito, Juichi; Tsuji, Jun; Sakakibara, Junji; Takeuchi, Mariko; Honjo, Iwao
Citation	音声科学研究 = Studia phonologica (1988), 22: 50-55
Issue Date	1988
URL	<a href="http://hdl.handle.net/2433/52500">http://hdl.handle.net/2433/52500</a>
Right	
Type	Departmental Bulletin Paper
Textversion	publisher

## Studies on Speech Perception by Multiple Cochlear Implant

Juichi ITO, Jun TSUJI, Junji SAKAKIBARA,  
Mariko TAKEUCHI and Iwao HONJO

### I. INTRODUCTION

Most patients with profound or total hearing loss cannot hear even with powerful hearing aids. Over the last two decades a number of medical centers have attempted to implant one or more electrodes in the cochlea of deaf patients to stimulate electrically the residual auditory nerve<sup>1)2)</sup>.

We have implanted Australian 22-channel implantable electrode<sup>3)</sup> into the cochleas of five total deaf patients. Three weeks after surgery rehabilitation was started. The vowel and consonant confusion tests were used to assess the recovery of hearing ability. Most patients showed good vowel confusion test results, whereas the results of consonant confusion test were insufficient. The speech discrimination abilities, that were estimated by speech tracking test, were good levels inspite of insufficient consonant recognition results. It is considered that although there have been many advantages by using cochlear implant, it has still not fully established. The purpose of the present paper is to show the results of a series of speech perception abilities conducted both our first and second cochlear implant patients and to indicate the shortcomings of the present implantable device and to think about the possibility of the improvement of future cochlear implantation.

### II. CLINICAL HISTOTY OF COCHLEAR IMPLANT PATIENTS

The first patient was a 55-year-old man who lost hearing completely following a head injury 19 months prior to the cochlear implant operation. Audiological tests under head-phones established that there was no hearing up to the limits of the audiometer for both ears. Electrical stimulation of the promontory indicated that some auditory nerve fibers were intact as the patient could perceive a tonal sensation with stimulation of the promontory at rates of 50, 100, 200, 400, and 800 pulses/second.

The second patient was a 50-year old man who lost hearing completely ten years prior to operation by unknown disease, probably labyrinthitis. Audiological tests and other tests results were almost same as the first case.

---

Juichi ITO (伊藤壽一), Jun TSUJI (辻 純), Junji SAKAKIBARA (榑原淳二), Mariko TAKEUCHI (竹内真理子), Iwao HONJI (本庄 巖): Department of Otolaryngology, Faculty of Medicine, Kyoto University.

### III. SPEECH DISCRIMINATION TESTS

#### 1) Method

Five Japanese vowels ; /a/, /i/, /u/, /e/ and /o/ ; were used for vowel confusion test. The test materials were presented with or without lipreading being involved. As for the consonant confusion test, thirteen consonants /D/, /B/, /G/, /Z/, /J/, /N/, /M/, /R/, /P/, /T/, /K/, /S/, /H/ were used as VCV structure such as /ADA/, /ABA/, etc.

In order to study the pattern of voicing confusions, the consonant stimuli were, according to the articulation process for speech production, classified into three groups ; voiced (/D/, /B/, /G/, /Z/, /J/, /N/, /M/, /R/), short unvoiced (/P/, /T/, /K/) and long unvoiced (/S/, /H/).

The performance with running speech and sentence were estimated by the speech tracking test and through several simple question and answer system.

#### 2) Results

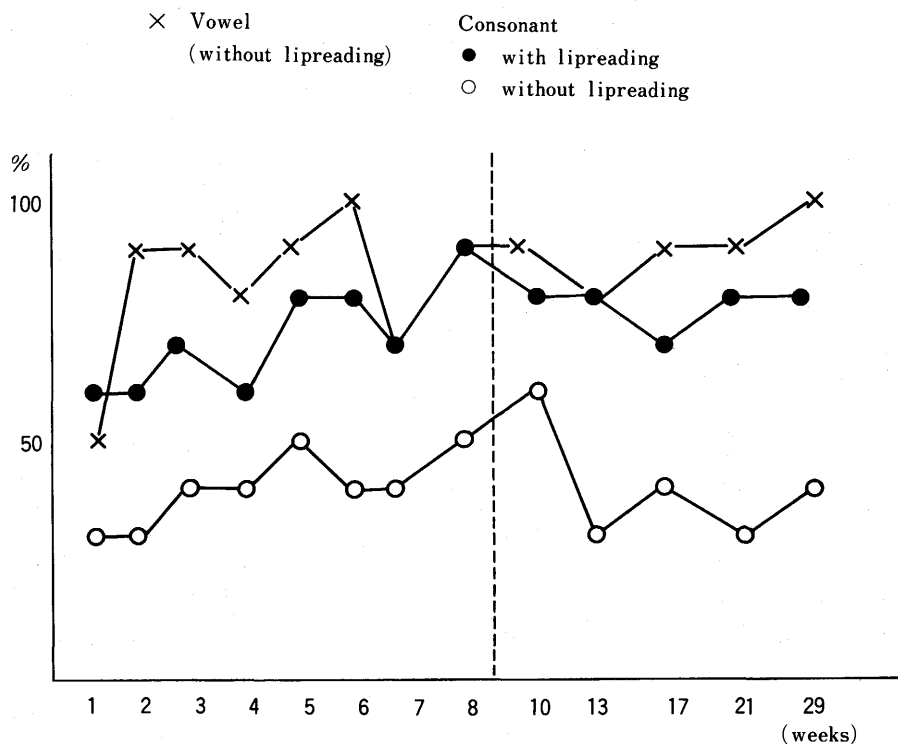

Fig. 1. Vowel and consonant recognition results.

The percentage correct scores for vowel and consonant confusion studies for the first patient are illustrated in Figure 1. The examples of vowel and consonant confusion matrix are shown in Table 1 and 2. The general patterns of vowel and consonant confusions generated by two patients were similar. They showed good

Table 1. Vowel Confusion Study

PATIENT : N. O.

Test Conditions :  
STIMULISpeech Processor alone  
RESPONSES

	A	I	U	E	O
A	5				
I		5			
U			4	1	
E				5	
O			2		3
TOTAL	5	5	5	5	5

NUMBER CORRECT=22 Out of 25=88%

Table 2. Consonant Confusion Study

PATIENT : N. O.

Test Conditions :  
STIMULISpeech Processor alone  
RESPONSES

	A	A	A	A	A	A	A	A	A	A	A	A	A
	M	P	B	N	T	D	S	Z	R	J	K	G	H
	A	A	A	A	A	A	A	A	A	A	A	A	A
AMA				2	1	1							
APA		1			1						2		
ABA	2	1	1										
ANA				3					1				
ATA		1			2						1		
ADA	1		3										
ASA							4						
AZA						2	1	1					
ARA					1			1	2				
AJA										4			
AKA					1						2		1
AGA			3									1	
AHA												1	3
TOTAL	3	3	7	5	6	3	5	2	3	4	5	2	4

NUMBER CORRECT=24 Out of 52=46%

vowel confusion test results whereas the consonants recognition abilities of both patients appeared to be equally insufficient. Voicing confusions among three groups (voiced, short unvoiced, long unvoiced) are given in Table 3. Data for one patient was pooled and the results from 273 presentations are summarized in the confusion matrix. The overall correct percentage for the consonants was 49 per cent. The individual correct percentage was 34 per cent for short unvoiced group, 71 per cent for the long unvoiced group and 52 per cent for the voiced group.

The ability of patients to identify some vowel and consonant features suggested that they should be able to comprehend some running speech without lipreading. Our observations with these patients have shown that they could comprehend without lip reading some sentences and phrases that were used every-

Table 3. Consonant confusions

Stimulus		Response													
		A D A	A B A	A G A	A Z A	A J A	A N A	A M A	A R A	A P A	A T A	A K A	A S A	A H A	
Voiced	ADA	7	4	2			1	4			3				
	ABA	5	5	6			1	2			2				
	AGA	1	9	3	4	1				2		1			
	AZA		3	1	11	4					1		1		
	AJA					21									
	ANA		1	2			10	3	5						
	AMA						8	9	4						
	ARA						3		18						
Short-unvoiced	APA	2		1						3	7	6	1	1	
	ATA	1		1						4	10	4		1	
	AKA	1		1							6	8		5	
Long-unvoiced	ASA		1							2	2	1	14	1	
	AHA	1		1							2		1	16	

day in the testing situation, for example “What TV program did you watch last night?”, “How old are you?”. Our study have shown that both first and second patients could identify ten sentences from a closed set with an accuracy of almost 100 per cent using cochlear implant alone.

#### IV. DISCUSSION

Australian 22-channel cochlear implant system is as follows<sup>3)</sup>. A pocket size speech-processor extracts formant signals (F0, F1, F2) and amplitudes of the first and second formants (A1, A2) are extracted and converted to current level. The estimated fundamental frequency is converted to electrical pulse rate and formant frequency to electrode position. These electrical parameters are fed into output and configured to transmission at radio frequencies to the implanted receiver-stimulator. This is illustrated in the block diagram in Figure .2.

In this system vowel descrimations are thought to be good, because the electrodes are selected by the first and second formant (F1, F2). On the other hand in terms of the strategy adopted in the speech processor design, consonant confusions can be analysed on the basis of the following two patterns : voicing confusions and transition confusions. The former refers to the voiced/unvoiced distinction, the latter to consonant identification based on the transitional characteristics of the second formant frequency.

In articulatory terms, the voiced consonants are produced by vocal cord

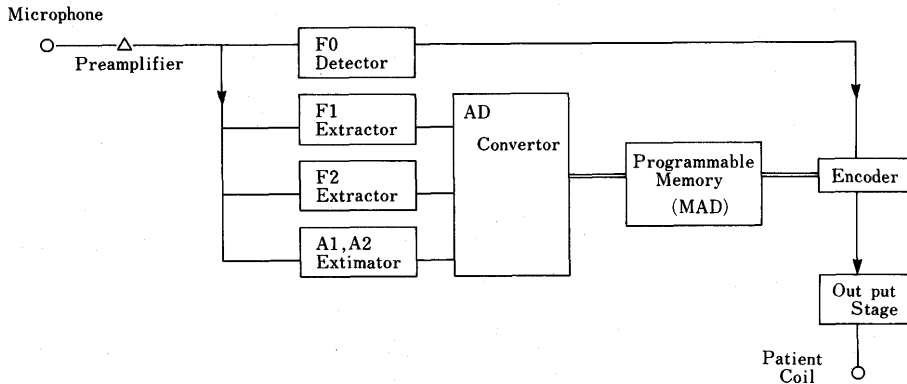

Fig. 2. A block diagram of the overall structure of the prosthesis.

excitation of the vocal tract, while the unvoiced consonants are produced from the excitation of the tract by noise which is generated by air flow at some point of constriction. Acoustically, voiced consonants correspond to periodic signals, while unvoiced consonants are noisy in character. The high percentage correct score for the long unvoiced group (71%) and the voiced group (52%) indicated that the patients were able to distinguish between voiced and unvoiced speech segments by paying attention to the roughness of the hearing sensation produced by electrical stimulation.

The present speech processor codes unvoiced segments as electrical stimuli at a low pulse rate, and codes voiced segments as stimuli with higher pulse rate. The present results suggested that this pulse rate differential is indeed an effective strategy for voiced/unvoiced encoding.

On the other hand the low percentage correct score in the short unvoiced group(34%) was the result of incorrect answer among the unvoiced group themselves.

The discrimination of consonants is more difficult than that of vowels, because the consonants involve much noise components and wider frequency components. And the limitation to discriminate consonants using this Australian formant-extract system is thought to be something around the results of our patients. To discriminate consonants more clearly, more detailed information should be demanded.

In spite of the insufficient consonant discrimination score, the patients' speech comprehension abilities are fairly good. This is presumed that once they have got speech discrimination network in their higher central nervous system, this network remains for a long period, even after they have lost their hearing sensation. And even with insufficient signals such as poor consonant discrimination signals that network may be activated again and patients might obtain speech comprehension ability.

As shown by many investigators cochlear implant is helpful for communication in real life situations. The observations that the patients' correct percentage

scores in the vowel and consonant studies are likely to be related to the amount of exposure to electrical stimuli, and the patients' ability to learn sentences encourage us to believe that the abilities of the patients to communicate by audition alone will be improved with further training.

However, the low percentage correct scores for the consonants and the restrictiveness of the vowel and consonant test materials indicated room for improvement, both in terms of the present speech processor design and the basic speech coding scheme. As far as the speech processor design is concerned, the estimation techniques employed in the speech parameter (F0, F1, F2,) extraction section are known to be inaccurate. New techniques, such as to use simultaneous stimulation system<sup>4)</sup> for consonant recognition and formant extraction system for vowel, are expected to improve their accuracy.

#### REFERENCES

- 1) Djourno A, Eyries C and Vallancien B : Premiers essais d'excitation électrique du nerf auditif chez l'homme ; par microappareils inclus à demeure. Bull Franc Nat Acad Med 141 : 481-483, 1957.
- 2) House WF and Urban J : Long term results of electrode implantation and electronic stimulation of the cochlea in man. Ann Otol Rhinol Laryngol 82 : 504-517, 1973.
- 3) Clark GM, Tong YC, et al : A multiple-electrode cochlear implant. J Otolaryngol Soc Aust 4 : 208-212, 1978.
- 4) Schindler RA, Kessler DK, et al : The UCSF/Storz multichannel cochlear implant ; patients results. Laryngoscope 96 : 597-603, 1986.

(Received Oct. 31, 1988)