

Title	Studies on regional differences in pre-inspiratory lung volume and pre-inspiratory alveolar N ₂ concentration by a single breath method
Author(s)	FUJITA, Masanori
Citation	京都大学結核胸部疾患研究所紀要 (1980), 13(1/2): 7-18
Issue Date	1980-03-31
URL	http://hdl.handle.net/2433/52184
Right	
Type	Departmental Bulletin Paper
Textversion	publisher

Studies on regional differences in pre-inspiratory lung volume and pre-inspiratory alveolar N₂ concentration by a single breath method

Masanori FUJITA

Department of Clinical Pulmonary Physiology, Chest Disease Research Institute, Kyoto University

An essential function of the lung is to exchange gas between venous blood and air, so that gas distribution is important only in relation to blood distribution. Yet, no simple method of measuring regional differences in \dot{V}_A/\dot{Q} without employing radioactive gases has been introduced after West reported his method in 1957¹⁾. Even though the measurement of uneven ventilation in the lung by a single breath O₂ method has come into routine use since Fowler's report²⁾ and it can provide an acceptable index of the presence of regional differences, this method cannot give any index corresponding to a particular region.

By the analysis of both Ar and N₂ measured after a single inspiration of Ar-O₂ mixture, we constructed a single compartment model in order to calculate pre-inspiratory lung volume ($V_{L\phi}$) and pre-inspiratory alveolar N₂ concentration ($F_A\phi_{N_2}$), and we evaluated the changes in $V_{L\phi}$ and $F_A\phi_{N_2}$ during the test expiration, as indices of regional differences in the ventilation and in the gas-exchange, respectively. Numerical values of $V_{L\phi}$ and $F_A\phi_{N_2}$ could be also assigned to a series of functional units having regional differences.

Symbols and nomenclature

- CO₂, Ar, N₂, O₂ : carbon dioxide, argon, nitrogen and oxygen
V_I, V_E : inspired and expired volume
V_{Da} : apparatus dead space
V_D : series dead space
V_L ϕ : pre-inspiratory lung volume
V_L : post-inspiratory lung volume
IT : inspiratory time
F_I : concentration in inspired gas
F_E : concentration in expired gas
F_A : post-inspiratory alveolar concentration
F_A ϕ_{N_2} : pre-inspiratory alveolar N₂ concentration

- mean F_A : mean alveolar concentration calculated by Cumming's method³⁾
- FRC-FRC+1L-RV : inspiration from FRC to 1 liter above FRC, then expiration to RV
- FRC-TLC-RV, RV-TLC-RV : inspirations from FRC and from RV, to TLC, then expiration to RV
- R.Q. : respiratory quotient
- \dot{V}_A/\dot{Q} : ventilation-perfusion ratio

MATERIALS AND METHOD

Measurements were done on nine spirometrically normal adults in the sitting position.

1) Equipments and procedures (Fig. 1)

After the preliminary period of resting tidal breathing through the mouthpiece, subjects were instructed to exhale to either FRC or RV, and then connected to Ar-O₂ mixture ($F_{IAr}=78.6\%$, $F_{IO_2}=21.4\%$) for an inspiration to the predetermined lung volume. The rotary solenoid 6-way valve was used and turned electrically. In the case of FRC-FRC+1L-RV maneuver, 1 liter inspired from FRC was recognized by the volume monitor fed by the electric out-put from the box spirometer (Ohio medical boxspirometer 840). Both inspiratory and expiratory flow rates were displayed on the oscilloscope and both kept below 0.5 liter/sec by subject's self-control. In FRC-FRC+1L-RV and FRC-TLC-RV maneuvers, Ar-O₂ mixture was inspired from FRC to 1 liter above FRC and to TLC, respectively, while it was inspired from RV to TLC in RV-TLC-RV maneuver. Then, full expiration was done to RV in all these maneuvers.

Four channels of a mass spectrometer (Varian M3) were selected at $m/e=28, 32, 40$ and 44 , and all the out-puts were processed through the electric data converter as fractional concentrations to avoid the effect of water vapor. The sampling capillary was heated up to about 50°C and placed within 7 cm of the subject's lips. The dead time, the response time for 90% of a deflection and the gas consumption were measured daily: 175-319 ms, 50-60 ms and 11 ml/min, respectively.

A digital computer (Nihon Kodan ATAC 2300) was used for all calculations including compensations for the dead time and major "cross-talk" from N₂O and CO as well as for the residual N₂ in the inspired gas (not more than 2% in this study) and the small constituent of expired Ar

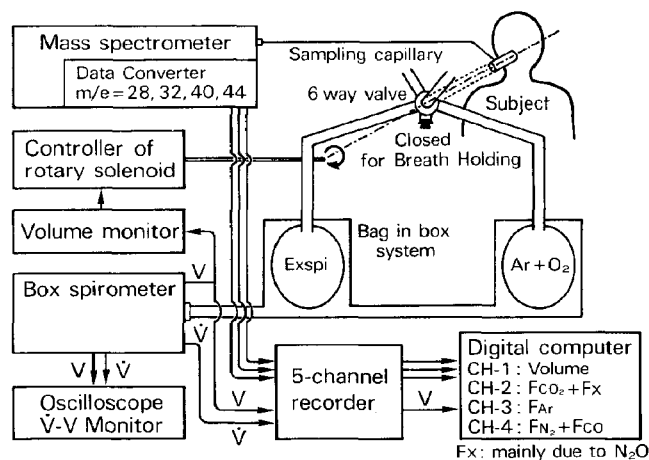

Fig. 1 Diagram of experimental arrangement

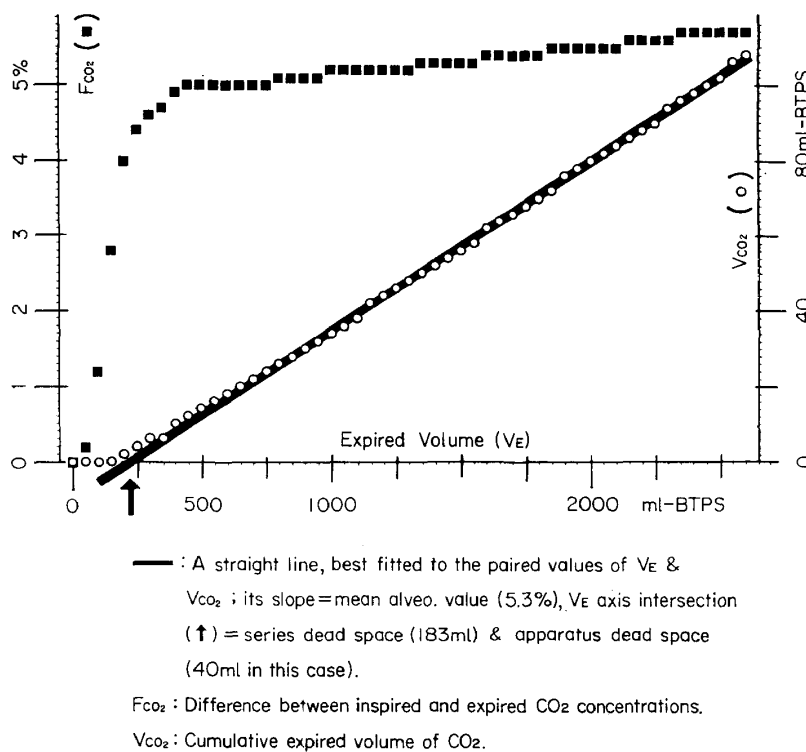

Fig. 2 Series dead space & Mean alveolar concentration, proposed by G. Cumming

derived from air on the assumption that their concentrations in the test expirate were proportional to F_{EAr} and to F_{EN_2} , respectively.

2) Definition of mean alveolar concentration (mean F_A), and series dead space (V_D) (Fig. 2)

G. Cumming³⁾ has found that there is a nearly linear relation between the whole expired volume and the cumulative expired volume for any particular gas components, i.e., the integrated product of the expiratory flow and the difference between concentrations in inspired and in expired gas, as shown in Fig. 2. Then, he applied this linearity to define the mean alveolar concentration which was necessarily accompanied by a new definition of a series dead space (V_D).

In the present study, a straight line was fitted to the paired values over the entire expiration in the first place, then the line was repeatedly re-calculated only beyond the V_E axis intersection of the previous line, until the line remained fixed.

The slope of this line gives the mean alveolar concentration and the point intersecting abscissa indicates the sum of the series dead space (V_D) and the apparatus dead space (V_{Da}).

3) Assumptions

When a single compartment model is assumed to include instantaneous complete gas mixing within the alveolar region, equations 1 and 2 can be given by the law of mass balance during the inspiration of Ar-O₂ mixture which is free from N₂ (Fig. 3). Subtraction of equation 2 from F_{IAr} gives equation 3, while dividing equation 1 by equation 3 and equation 3 by equation 2 give equations 4 and 5, respectively.

In the present study, the wash-out volume was assumed to be 3 times the series dead space, and the expirate beyond this wash-out volume was assumed to have the alveolar gas composition without inspired gas contamination.

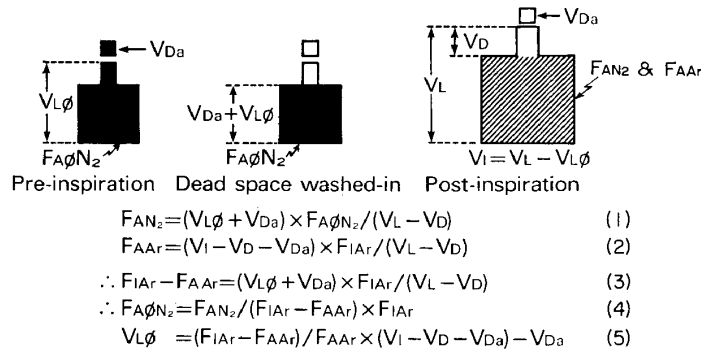

Fig. 3 Single compartment model

The pre-inspiratory alveolar N_2 concentration ($F_{A\phi}N_2$) and the pre-inspiratory lung volume ($V_L\phi$) were calculated by substitution of F_{EAR} and/or F_{EN_2} for F_{AAr} and/or F_{AN_2} , respectively in equations 4 and 5, continuously over the entire expiration. However, the changes were evaluated only in the range beyond the wash-out volume, and were assumed to reflect sequential emptying and varied contributions of various lung regions having regional differences, while the phase 3 was defined to begin just after the wash-out volume. Mean $F_{A\phi}N_2$ and mean $V_L\phi$ were calculated by substitution of mean F_{AAr} and/or mean F_{AN_2} for F_{AAr} and/or F_{AN_2} , respectively in equations 4 and 5.

In appendix we refer to the critique of these calculations in the presence of continued gas exchange and the stratification in addition to the sequential emptying, because we neglected the former two factors and used F_{EAR} and F_{EN_2} in the place of F_{AAr} and F_{AN_2} .

4) Discrimination of the phase 4 by the computer

This was done by using West's method⁴⁾ with a slight modification: calculation of a straight line best fitted to the phase 3 was started from the wash-out volume in the place of 30% VC, because we defined the phase 3 to begin just after the wash-out volume.

RESULTS

1) Series dead space (V_D) (Table 1)

In Table 1, the average V_D values obtained by Cumming's method are presented to compare them with Fowler's V_D values⁵⁾ predicted from Hart's formula⁶⁾ and to find possible differences in those values among various gases.

In the procedures FRC-FRC+1L-FRC (a) and FRC-TLC-FRC (b), calculations were based on the data only between postinspiratory volumes (FRC+1 liter (a), TLC (b)) and FRC, though the actual test expiration was stopped not at FRC, but at RV.

In the case of FRC-FRC+1L-FRC procedure, V_D for N_2 was smaller than that predicted by Hart in 3 out of 9 subjects, and V_D for CO_2 was always found larger than those for Ar and for N_2 , both of which were comparable.

On the contrary, V_D for N_2 obtained by FRC-TLC-FRC procedure exceeded the predicted value in 3 out of 9 subjects. In FRC-TLC-FRC procedure, V_D was generally increased for all

Table 1 Comparison of series dead space with predicted values from Hart's formula, and among various gases.

Subject	AF	WS	KS	MF	YL	MO	MM	TL	KO	
Age & Sex	24·F	29·F	31·M	30·M	39·M	29·M	25·M	29·M	38·M	
Weight (kg)	42	57	56	75	80	57	75	78	85	
Height (cm)	158	163	160	170	174	174	179	180	182	
Prediction of V _D (ml)	(1)	118±20	122±20	128±21	141±23	149±25	149±25	159±26	161±27	166±28
	(2)	103±21	131±27	129±27	164±34	173±36	131±27	164±34	169±35	182±38
a) FRC—FRC+1L—FRC procedure										
IT (sec)	9	1.8	5.6	5.8	2.8	5.4	4.4	4.2	3.7	
V _D (ml-BTPS)	CO ₂	95	116	120	121	158	136	157	126↓	136↓
	Ar	90	111	115	108↓	141	123	154	120↓	125↓
	N ₂	90	111	114	108↓	141	123	154	121↓	126↓
b) FRC-TLC-FRC procedure										
IT (sec)	14.5	8.7	19.1	14.2	13.6	8.8	11.4	14.7	21.4	
V _D (ml-BTPS)	CO ₂	104	134	201↑	225↑	184	259↑	273↑	228↑	191
	Ar	93	118	189↑	180	148	225↑	233↑	179	156
	N ₂	95	118	189↑	187	158	227↑	234↑	182	161

(1) = $7.585 \times \text{Ht}^{2.363} \times 10^{-4} \pm 16.9\%$, (2) = $1.835 \times \text{Wt} + 26.59 \pm 21.2\%$ by Hart et al.

↑: higher, ↓: lower value than the predicted from whichever formula.

IT: Inspiratory time. V_D: Series dead space. IT & V_D are presented as average values for each subject.

gases and in all subjects. However, V_D for CO₂ was always larger than V_D for Ar or N₂, while the latter two remaining comparable to each other, as was the case in the former procedure.

Since the accuracy of Fowler's method was confirmed in tests on the actual model with a known dead space⁷⁾, Cumming's method may systematically underestimate the actual anatomical geometry and dimension. However, Fowler's method is difficult to define the alveolar gas and deals with only the expirate of wash-out volume, forming the contrast with Cumming's method which can define the alveolar gas appropriately through the entire expiration. But, increase in V_D due to the increased post-inspiratory lung volume, i.e., from FRC+1 liter up to TLC, was observed also in the present study as was found in studies using Fowler's method.^{5), 6)} Consistently observed difference in V_D between CO₂ and Ar or N₂ may be ascribed to the difference in alveolar plateaus, because Fowler's V_D is believed to have practically no significant difference among various gases.^{8), 9)}

2) FRC/TLC, RV/TLC and their regional differences detected during the phases 3 and 4 (Table 2)

In FRC-TLC-RV maneuver, V_Lφ and (V_Lφ+V_i) correspond to FRC and TLC, respectively while V_Lφ corresponds to RV in the case of RV-TLC-RV maneuver.

Since at TLC the volume of the lung units should be uniform throughout the lung, regional V_Lφ/TLC is always proportional to the corresponding V_Lφ in spite of the presence of regional difference in V_Lφ. Thus, changes of V_Lφ/(mean V_Lφ+V_i) during the phases 3 and 4 indicate

Table. 2 FRC/TLC, RV/TLC and their regional differences detected during the phases 3 and 4.

$V_L\phi/(V_L\phi+V_I)$	Mean	Maximum	Minimum
a) FRC/TLC %	50.8±6.8	66.1±8.5	44.9±5.7
b) RV/TLC %	22.2±3.9	30.8±6.3	19.9±3.3

The values of a and b were obtained by FRC-TLC-RV and RV-TLC-RV maneuvers, respectively.

All figures are expressed as mean±SD.

$V_L\phi$: Pre-inspiratory lung volume. V_I : Inspired volume.

Table. 3 Mean $FA\phi N_2$, regional difference in $FA\phi N_2$ detected during the phases 3 and 4, and mean R.Q.

	Mean $FA\phi N_2$	Maximum $FA\phi N_2$	Minimum $FA\phi N_2$	$FA\phi N_2$ gradient	Mean R.Q.
FRC-FRC+1L-RV	80.8±1.8 %	81.2±1.9 %	79.0±1.2 %	2.1±1.1 %	0.80±0.18
FRC-TLC-RV	80.5±2.4 %	82.6±3.0 %	79.2±1.9 %	3.4±1.3 %	0.79±0.26
t-test	NS	P<0.05	NS	P<0.05	NS

$FA\phi N_2$ gradient indicates the difference between maximum $FA\phi N_2$ and minimum $FA\phi N_2$.

All figures are expressed as mean±SD.

the regional difference in FRC/TLC or RV/TLC, only disclosed by any existent sequential emptying. The changes were expressed as its maximum and minimum during the phases 3 and 4. FRC/TLC and RV/TLC were calculated and gave acceptable mean values of 50.8 and 22.2% with maxima of 66.1 and 30.8%, and minima of 44.9 and 19.9%, respectively.

$V_L\phi$ can be underestimated in the presence of a breath holding effect and unduly influenced by the gas from regions having larger contribution to the expirate, as discussed later. But, maximal and minimal values during the phases 3 and 4 were strikingly in accord with topographical data reported by Sutherland et al.¹⁰⁾ who also controlled the inspiratory flow rate not to exceed 0.5 liter/sec, since the inspiratory flow rate has been shown to affect the ventilation distribution.¹¹⁾

3) Mean $FA\phi N_2$, regional difference in $FA\phi N_2$ detected during the phases 3 and 4, and mean R.Q. (Table 3)

Acceptable mean $FA\phi N_2$ values of 80.0% and 80.5% were obtained in FRC-FRC+1L-RV and FRC-TLC-RV maneuvers, respectively. The same as in the case of $V_L\phi$, $FA\phi N_2$ change during expiration was thought to reflect its regional difference and was expressed as maximum and minimum during the phases 3 and 4. Then, the difference between the maximum and minimum was defined to be $FA\phi N_2$ gradient.

The difference between $FA\phi N_2$ gradient in FRC-FRC+1L-RV maneuver and that in FRC-TLC-RV maneuver, i.e., 2.1±1.1% and 3.4±1.3%, respectively, was of statistical significance probably because of the increased maximum $FA\phi N_2$ in the case of full inspiration to TLC (FRC-TLC-RV maneuver), during which the regions having lower R.Q. and resultant higher $FA\phi N_2$ were recruited for ventilation, making more contribution to the expirate than in FRC-FRC+1L-RV maneuver. Maximum $FA\phi N_2$ of 81.2% in FRC-FRC+1L-RV maneuver which approximated a tidal breath, was in concordance with topographical data from West's model.^{12),13)}

Other numerical values of $FA\phi N_2$ in Table 3 are also compatible with West's data, when

it is taken into account that the present method can be unduly influenced by the gas from well-ventilated regions and sensitive to intraregional inequalities. Calculations of mean R.Q. were made by substitution of mean FAO₂ and mean FACO₂ into the general alveolar gas equation. Acceptable values of 0.80 and 0.79 were obtained from FRC-FRC+1L-RV and FRC-TLC-RV maneuvers, respectively.

4) Changes in FE_{CO}₂, FEN₂, FAφN₂, R.Q. and VLφ during expiration (Fig. 4, Fig. 5)

A representative case without discernible phase 4 was shown in Fig. 4a. Pre-inspiratory FAN₂ (FAφN₂) made a gradually rising plateau until RV. But, FAφN₂ deflected downwards in agreement with FE_{CO}₂ deflection at systole of cardiogenic oscillations, where both FEN₂ and R.Q. had upward deflections. These oscillations were all reversed at diastole.

When the same maneuver developed the phase 4 in another subject (Fig. 4b), FAφN₂ and FE_{CO}₂ curves were deflected downwards there, corresponding with the abrupt upward deflection of FEN₂.

For detailed study on the phase 4, the case with clearly discernible phase 4 was presented in Fig. 4c, which revealed recognizable upward deflection of R.Q. curve also. Thus, both phase 4 and systolic oscillations imposed downward deflections to FAφN₂ and FE_{CO}₂, and upward deflections to FEN₂ and R.Q.

Additional remarks must be made here about the terminal stage of an apparent phase 3. At this stage, there were found striking rises in FAφN₂ and FE_{CO}₂ and striking falls of FEN₂ and R.Q. These changes were comparable to those found in the phase 4 though in the reciprocal way. This phenomenon is clearly visualized in Fig. 5b, which discloses a striking fall in VLφ in addition. This phenomenon can be best explained by the assumption that there may be considerable exaggeration of sequential emptying (and/or closure) well before the start of the phase 4,

Fig. 4 Changes in FE_{CO}₂, FEN₂, pre-inspiratory alveolar N₂ concentration (FAφN₂), and R. Q., during expiration.

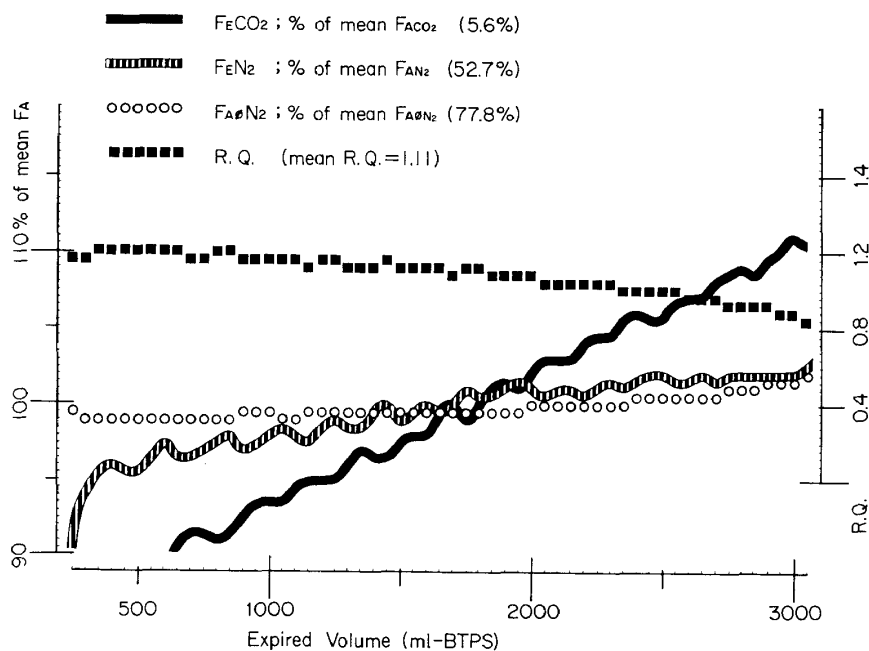

Fig. 4a Subject WS; FRC-FRC+1L-RV maneuver

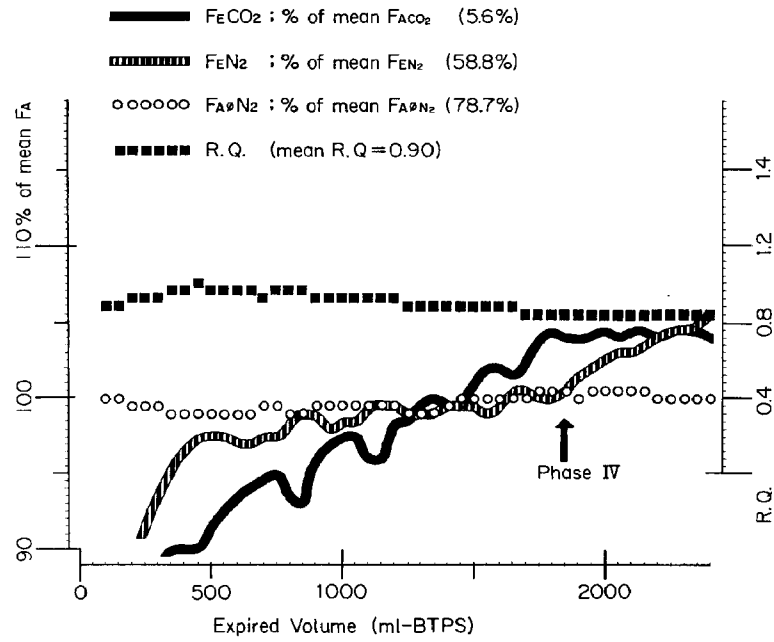

Fig. 4b Subject KS; FRC-FRC+1L-RV maneuver

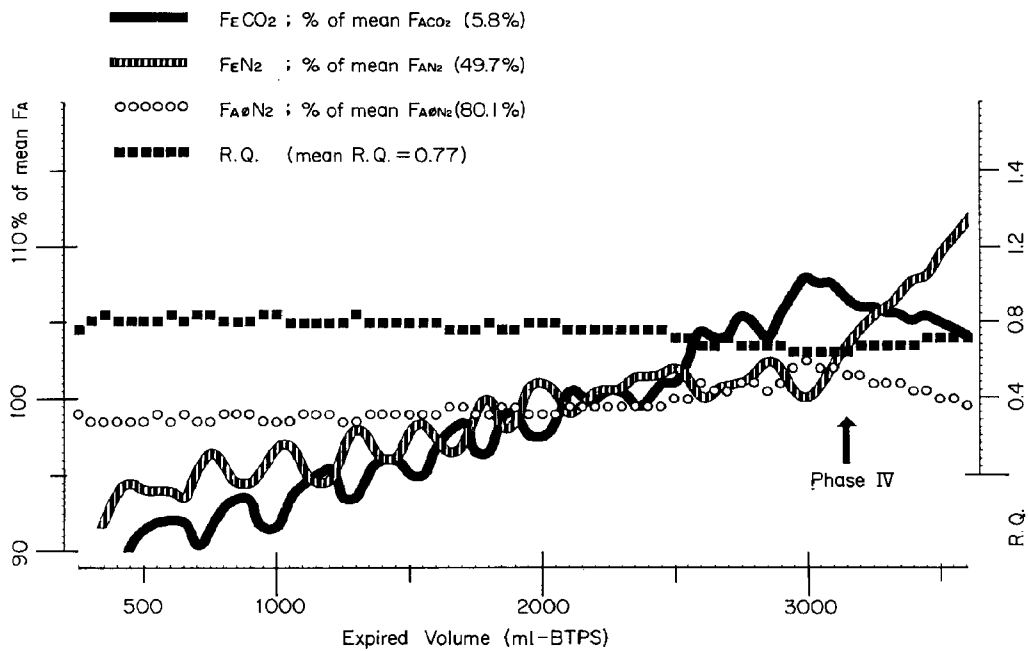

Fig. 4c Subject KS; FRC-TLC-RV maneuver

and that the deflections of curves, in the opposite way to those in the phase 4, were caused by decreased contribution of lung regions having higher RV/TLC (or FRC/TLC) ratio, higher R.Q. with lower $F_{A}\phi N_2$ and higher $F_{A}N_2$, all of which are characteristics of the upper regions in the erect healthy human lung. And, this is the usual explanation also for the diastolic oscillations.¹⁴⁾ Even if the phase 3 of $F_{E}N_2$ record only made a slightly rising plateau as in the case of Fig. 5a, both $F_{A}\phi N_2$ and $V_L\phi$ showed the same trend as in Fig. 5b.

Fig. 5 is presented to investigate which of the two factors, i.e., the regional RV/TLC and regional $F_{A}\phi N_2$ differences, can be the principal determinant of the constitution of $F_{E}N_2$ recorded

Fig. 5 Changes in pre-inspiratory lung volume ($V_L\phi$), F_{EN_2} and pre-inspiratory alveolar N₂ concentration ($F_{A\phi N_2}$), during expiration.

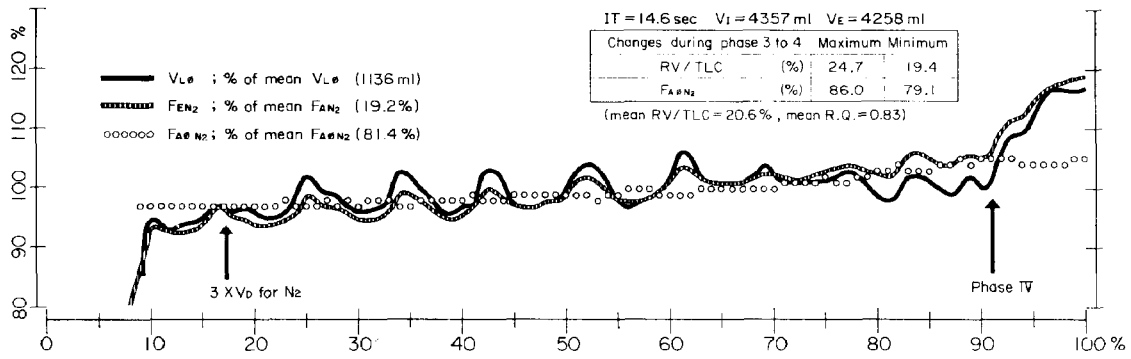

Fig. 5a Subject MO; RV-TLC-RV maneuver

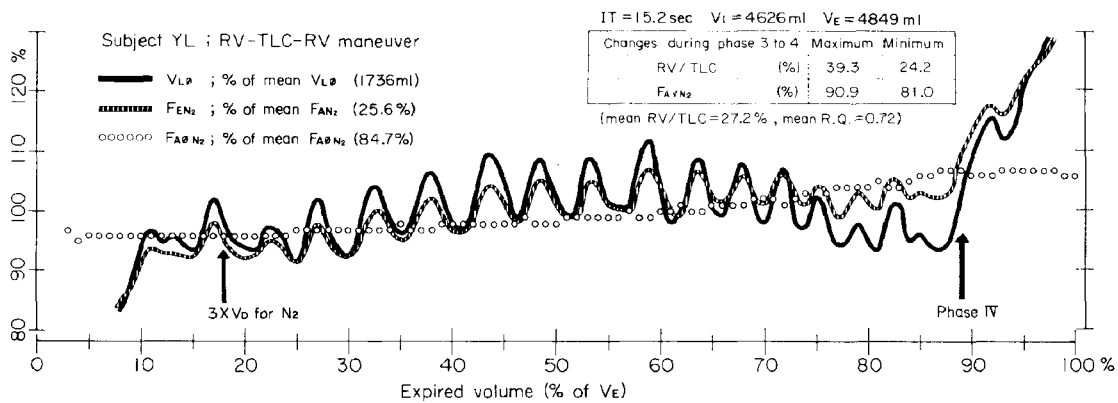

Fig. 5b Subject YL; RV-TLC-RV maneuver

by either O₂ or Ar-O₂ single breath method.

Since the breath holding effect during the test expiration makes $V_L\phi$ falsely smaller and $F_{A\phi N_2}$ falsely larger than those obtained in the absence of this effect as discussed in appendix, general upward sloping of $V_L\phi$ can be underestimated, and that of $F_{A\phi N_2}$ overestimated. On the other hand, relative changes in cardiogenic oscillations, terminal phase 3 and phase 4 are reasonably assumed to remain free from the breath holding effect because these changes take place rapidly.

Thus, F_{EN_2} changes in general sloping and in cardiogenic oscillations, terminal phase 3 and phase 4 can be concluded to reflect the regional difference of RV/TLC ratios rather than the difference in pre-inspiratory F_{AN_2} ($F_{A\phi N_2}$); the latter has less general sloping and shows relative change in the opposite way to F_{EN_2} , dampening the changes in F_{EN_2} .

DISCUSSION AND CONCLUSION

Mixed alveolar gas is difficult to define because of contamination with gas from the anatomical dead space; the latter is usually estimated in practice by Fowler's method based on the arbitrarily adopted alveolar gas composition.

G. Cumming has proposed a new method³⁾ to obtain mixed alveolar gas composition (called

mean alveolar concentration in the present study), by means of which calculations of mean values were made possible for pre-inspiratory lung volume ($V_L\phi$), pre-inspiratory alveolar N_2 ($F_A\phi_{N_2}$) and respiratory quotient (R.Q.), although what was actually defined by this method remains to be appreciated.

Since the maximum exchange across the alveolar membrane is negligible for both N_2 and Ar because of their low solubility¹⁵⁾, this exchange is assumed to introduce no significant error in this study including measurement of R.Q. following inspiration of Ar- O_2 mixture in the place of N_2 - O_2 mixture, i.e., air.

The re-distribution of a dead space at the beginning of inspiration will affect $F_A\phi_{N_2}$ and make its regional difference underestimated in the healthy lung, but was not taken into account in this paper.

It should be pointed out that the present study was concerned about the regional differences in R.Q. that could be produced by the inspired gas to give any particular alveolar gas compositions, as was the case in West's report.¹⁾ Therefore, R.Q. in the present study is entirely different from the instantaneous R ¹⁶⁾ that could be produced by any particular alveolar gas compositions in a homogeneous alveolar gas phase and in the absence of sequential emptying.

In the present study, the direction of R.Q. deflection during expiration apparently corresponded with $F_A\phi_{N_2}$ deflection though in a reciprocal manner. However, allowance should be made for some fall in R.Q. due to gas exchange continuing during expiration in order to derive accurate index of \dot{V}_A/\dot{Q} inequality from R.Q. or its substitutes. This gas exchange effect was reported by Meade et al.¹⁷⁾ to account for 2/3 of the apparent % change in \dot{V}_A/\dot{Q} between 750 ml and 1250 ml samples.

In appendix, we discuss this breath holding effect of continued gas exchange as well as of decaying stratification during the time lapse between early and late expirate though only in the qualitative way.

Nevertheless, such relative changes within a short time as cardiogenic oscillations and striking deflections in terminal phase 3 and phase 4 are reasonably assumed to be produced not by this breath holding effect, but by accentuated sequential emptying and/or air way closure. The apparent decrease in F_{EN_2} in the terminal phase 3 also contradicts the effects of continued gas exchange.

When changes in $F_A\phi_{N_2}$ and $V_L\phi$ were compared with the topographical differences found in the erect healthy human lung, it was assured that both systolic cardiogenic oscillations and the phase 4 deflection were related with markedly increased contribution of the upper lung regions. On the other hand, the deflection in the terminal phase 3 that has been neglected so far, as well as diastolic oscillations was concluded to reflect the decreased contribution of upper lung regions, forming the contrast to the phase 4 and systolic oscillations.

As for F_{EN_2} record on a conventional single breath O_2 method, F_{EN_2} was found to be governed by regional ventilation distribution, as has been advocated since Fowler's report was published.²⁾

On the contrary, $F_A\phi_{N_2}$ change was directed to dampen F_{EN_2} change.

In conclusion, it was suggested that though without direct topographical informations, the present method could provide measurements for regional differences and mean overall values of both ventilation and pre-existing alveolar N_2 concentration reflected in the test expirate. More-

over, we have afforded a new insight into the mechanism that underlies the conventional FEN₂ record.

APPENDIX

Rearranging equation 5 in Fig. 3 gives

$$V_L\phi = (F_{IAr}/F_{AAR} - 1) \times (V_I - V_D - V_{Da}) - V_{Da} \quad (6)$$

Dividing equation 1 by equation 2 gives

$$F_{AN_2}/F_{AAR} = (V_L\phi + V_{Da}) \times F_A\phi_{N_2} / (V_I - V_D - V_{Da}) / F_{IAr} \quad (7)$$

If a breath holding effect is taken into account during a test expiration, then continued gas exchange should be associated with an increase in F_{AAR} because of less dilution or more concentration due to lowering of R.Q. induced by it. Thus, F_{IAr}/F_{AAR} in equation 6 becomes smaller with falsely smaller V_Lφ, while F_Aφ_{N₂} will be calculated falsely larger, because F_{AN₂}/F_{AAR} in equation 7 is believed to be constant, though each gas is affected in the same way by continued gas exchange.¹⁵⁾

In the second place, since stratification, if any, will be reduced by a breath holding effect, F_{AAR} will become larger in the later expirate with the axial gradient for Ar, i.e. (F_{IAr} - F_{AAR}), reduced, leading to falsely smaller V_Lφ in this time also. But, because decaying of stratification is proportional to the axial concentration gradient, i.e., (F_{AN₂} - F_{IN₂}) for N₂ and (F_{IAr} - F_{AAR}) for Ar, (F_{AN₂} - F_{IN₂}) / (F_{IAr} - F_{AAR}) remains constant. When F_{IN₂} = 0 as in the present study, F_{AN₂} / (F_{IAr} - F_{AAR}) in equation 4 in Fig. 3 becomes also constant and thus, F_Aφ_{N₂} is not affected by the presence of stratification.

In summary, a breath holding effect, whether by means of continued gas exchange or of decaying stratification, is expected to make the calculated V_Lφ falsely smaller, but F_Aφ_{N₂} will become falsely larger only in the presence of continued gas exchange.

REFERENCES

- 1) West, J. B., Fowler, K. T., Hugh-Jones, P. and O'Donnell, T. V.: Measurement of the ventilation-perfusion ratio inequality in the lung by the analysis of a single expirate. *Clin. Sci.*, 16: 529, 1957.
- 2) Fowler, W. S.: Lung function studies. III. Uneven pulmonary ventilation in normal subjects and in patients with pulmonary disease. *J. Appl. Physiol.*, 2: 283, 1949.
- 3) Cumming, G.: Personal communication.
- 4) West, J. B., Guy, H. J., Gaines, R. A., Hill, P. M. and Wagner P. D.: Battery of single-breath tests for rapid measurement of pulmonary function using a respiratory mass spectrometer. *Pneumologie*, 151: 258, 1975.
- 5) Fowler, W. S.: Lung function studies. II. The respiratory dead space. *Am. J. Physiol.*, 154: 405, 1948.
- 6) Hart, M. C., Orzalesi, M. M. and Cook, C. D.: Relation between anatomic respiratory dead space and body size and lung volume. *J. Appl. Physiol.*, 18: 519, 1963.
- 7) Birath, G.: Respiratory dead space measurements in a model lung and healthy human subjects according to the single breath method. *J. Appl. Physiol.*, 14: 517, 1959.
- 8) Bartels, J., Severinghaus, J. W., Forster, R. E., Briscoe, W. A. and Bates, D. V.: The respiratory dead space measured by single breath analysis of oxygen, carbon dioxide, nitrogen or helium. *J. Clin. Invest.*, 33: 41, 1954.

- 9) Wagner, P. D., Gaines, R. A., Mazzone, R. W. and West, J. B.: Mechanism of intrapulmonary gas mixing during breathholding in man (Abstract). *Physiologist*, 15: 295, 1972.
- 10) Sutherland, P. W., Katsura, T. and Milic-Emili, J.: Previous volume history of the lung and regional distribution of gas. *J. Appl. Physiol.*, 25: 566, 1968.
- 11) Robertson, P. C., Anthonisen, N. R. and Ross, D.: Effect of inspiratory flow rate on regional distribution of inspired gas. *J. Appl. Physiol.*, 26: 438, 1969.
- 12) West, J. B.: Regional differences in gas exchange in the lung of erect man. *J. Appl. Physiol.*, 17: 893, 1962.
- 13) West, J. B.: Regional differences in the lung. Academic Press, New York. 1977. P210.
- 14) Fowler, K. T. and Read, J.: Cardiac oscillations in expired gas tensions, and regional pulmonary blood flow. *J. Appl. Physiol.*, 16: 863, 1961.
- 15) Sikand, R., Cerretelli, P. and Farhi, L. E.: Effect of \dot{V}_A and \dot{V}_A/\dot{Q} distribution and of time on the alveolar plateau. *J. Appl. Physiol.*, 21: 1331, 1966.
- 16) Kim, T. S., Rahn, H. and Farhi, L. E.: Estimation of true venous and arterial PCO_2 by gas analysis of a single breath. *J. Appl. Physiol.* 21: 1338, 1966.
- 17) Meade, F., Pearl, N. and Saunders, M. J.: Distribution of lung function (\dot{V}_A/\dot{Q}) in normal subjects deduced from changes in alveolar gas tensions during expiration. *Scand. J. Resp. Dis.*, 48: 354, 1967.