

Title	Preliminary studies on diffusion coefficients of gases at pressures
Author(s)	Osugi, Jiro; Hiraoka, Hiroyuki; Shinoda, Daizaburo
Citation	The Review of Physical Chemistry of Japan (1958), 28(1): 36-41
Issue Date	1958
URL	<a href="http://hdl.handle.net/2433/46761">http://hdl.handle.net/2433/46761</a>
Right	
Type	Departmental Bulletin Paper
Textversion	publisher

## PRELIMINARY STUDIES ON DIFFUSION COEFFICIENTS OF GASES AT PRESSURES

BY JIRO OSUGI, HIROYUKI HIRAOKA AND DAIZABURO SHINODA

### Introduction

The transport of matter takes place by the process due to molecular diffusion. Lately, chemical engineering having been highly developed, informations on diffusion at high pressures are indispensable for handling high pressure plants.

When there is a concentration gradient in a mixture at constant temperature and pressure, molecules come repeatedly into collision due to thermal motion and finally the concentration gradient disappears.

As a result of kinetic theory and a number of many experimental investigations, the laws governing the diffusion of gases at low pressures have been well elucidated. On the other hand, comparatively little is known about the diffusion of gases at elevated pressures. The dense gas theory of D. Enskog<sup>1)</sup> based on the hard sphere molecular model is at present the most useful theoretical treatment. Pioneering experimental work in the field of diffusion at elevated pressures has been reported by H. G. Drickamer and his coworkers. W. L. Robb and H. G. Drickamer<sup>2)</sup> and K. D. Timmerhans and H. G. Drickamer<sup>3)</sup> measured the diffusion rates in the system  $C^{14}O_2-C^{12}O_2$  at temperatures from 0°C to 50°C and at pressures up to 1000 atm. A similar measurement has been reported by H. A. O'Hern and J. J. Martin<sup>4)</sup> who measured by the different method. Those were performed to 25 atm at 0°C, to 98 atm at 35°C and to 205 atm at 100°C. Measurements on systems,  $CH_4-TCH_3$  and  $CH_4-CO_2$ , at pressures up to 300 atm, have been reported by Q. R. Jeffries and H. G. Drickamer<sup>5)</sup>. The results obtained by H. G. Drickamer and his coworkers agree with D. Enskog's theory within experimental errors, but H. A. O'Hern and J. J. Martin reported the different results.

In the present experiment, the authors measured diffusion rates in the system  $CO_2-O_2$  at pressures up to 30 kg/cm<sup>2</sup> and the temperature range 5°~45°C as a preliminary study on high pressure diffusion.

### Experimentals

The diffusion cell used is similar to the Loschmidt type<sup>6)</sup> and is shown in Fig. 1. The

1) S. Chapman and T. C. Cowling, *The Mathematical Theory of Non-uniform Gases*, Cambridge University Press, London (1939)

2) W. I. Robb and H. G. Drickamer, *J. Chem. Phys.*, **19**, 1504 (1951)

3) K. D. Timmerhans and H. G. Drickamer, *ibid.*, **19**, 1242 (1951)

4) H. A. O'Hern and J. J. Martin, *Ind. Eng. Chem.*, **47**, 2081 (1955)

5) Q. R. Jeffries and H. G. Drickamer, *J. Chem. Phys.*, **21**, 1358 (1953)

6) Q. R. Jeffries and H. G. Drickamer, *ibid.*, **22**, 436 (1954)

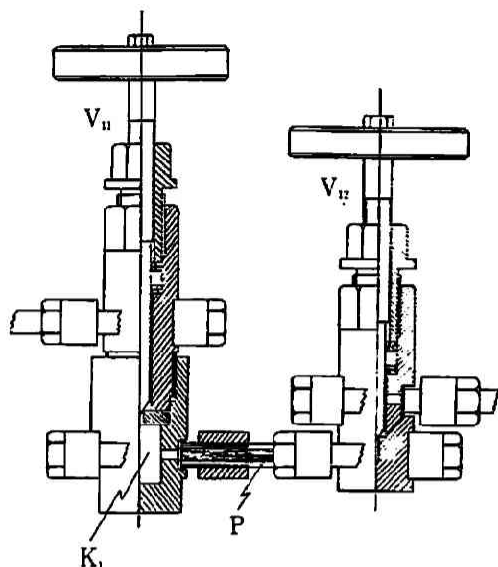

Fig. 1 Diffusion cell

K<sub>1</sub>: chamber

P: diffusion path

chambers K<sub>1</sub> and K<sub>2</sub> are about 3 cm<sup>3</sup> in capacity. P is a diffusion path made of a steel pipe which is filled with copper wire to slow down a diffusion rate.

The layout of the apparatus is shown in Fig. 2. The other auxiliary apparatus consist of a

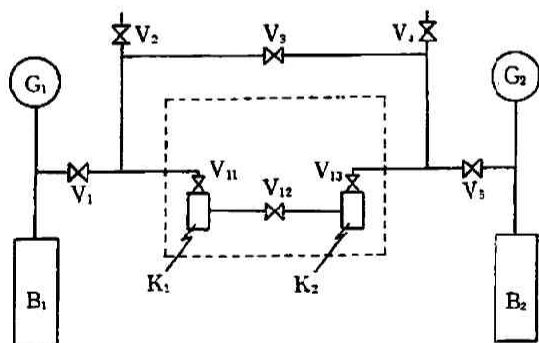

Fig. 2 Layout of the equipment

vacuum pump, thermostat and gas analytical device. The temperature of the diffusion cell is kept constant within  $\pm 0.02^\circ\text{C}$  and the pressure within  $\pm 0.1\text{atm}$  throughout the experiments of diffusing runs.

The experimental procedure is as follows. At the beginning, all the system except the reservoirs B<sub>1</sub> and B<sub>2</sub> is evacuated through the valves V<sub>2</sub> and V<sub>4</sub> and then V<sub>2</sub>, V<sub>3</sub>, V<sub>4</sub> and V<sub>12</sub> are closed. Next, gases 1 and 2 in the reservoirs B<sub>1</sub> and B<sub>2</sub> are poured into the chambers K<sub>1</sub> and K<sub>2</sub> up to a given pressure and the valves V<sub>1</sub> and V<sub>5</sub> are immediately closed. In order to balance the pressures of the chambers K<sub>1</sub> and K<sub>2</sub>, valve V<sub>3</sub> is opened for a short time. After that V<sub>11</sub> and V<sub>13</sub> are closed. Then the diffusion runs are started by the opening of the valve V<sub>12</sub>. After a given time, the valve V<sub>12</sub> is closed. The gas contained in the chamber K<sub>1</sub> or K<sub>2</sub> is measured with a gas burette and the concentration of each component of the gas mixture is analysed by Hempel's method.

## Results

To obtain experimental diffusion coefficients, it is necessary to solve the diffusion equation taking into consideration of the geometry of the system. F. Hutchinson<sup>7)</sup> and W. Jost have given the following derivation of the relation for the two-chamber diffusion cell, from the assumption of an essentially linear concentration gradient in the diffusion path. Let  $C_1$  and  $C_2$  be the concentrations of a diffusing component in the chambers  $K_1$  and  $K_2$ , and  $L$  be the length of the path connecting  $K_1$  with  $K_2$ . Assuming the concentration in each chamber as uniform, the linear concentration gradient in the path is

$$\frac{dC}{dx} = \frac{(C_1 - C_2)}{L} \dots\dots\dots(1)$$

The expressions for the rates of change of concentrations in the two chambers can be written, using Fick's law

$$\frac{dC_1}{dt} = - \frac{Da}{V_1} \frac{(C_1 - C_2)}{L} \dots\dots\dots(2)$$

and

$$\frac{dC_2}{dt} = \frac{Da}{V_2} \frac{(C_1 - C_2)}{L}, \dots\dots\dots(3)$$

where  $V_1$  and  $V_2$  are the chamber volumes,  $D$  is the diffusion coefficient and  $a$  is the cross-sectional area of the path.

Subtracting Eq. (3) from Eq. (2), Eq. (4) is obtained :

$$\frac{d(C_1 - C_2)}{dt} = - \frac{Da}{L} \left( \frac{1}{V_1} + \frac{1}{V_2} \right) (C_1 - C_2). \dots\dots\dots(4)$$

Eq. (4) is readily integrated to

$$\ln(C_1 - C_2) = - KDt + Const., \dots\dots\dots(5)$$

where

$$K = \frac{a}{L} \left( \frac{1}{V_1} + \frac{1}{V_2} \right).$$

From the experimental data,  $\ln(C_1 - C_2)$  against time,  $t$ , can be plotted for each experimental diffusion run. If such a plot is linear, the slope must represent the product of a diffusion coefficient and a cell constant. If the cell constant  $K$  is known, the diffusion coefficient can be obtained from the slope. At the present investigation, it is necessary to determine the constant  $K$  experimentally using the data of low pressure measurement already published, since the path is packed with copper wire to slow down the diffusion rate. Typical plots of  $\log(C_1 - C_2)$  versus time at 25°C and 5kg/cm<sup>2</sup> used to determine the cell constant is shown in Fig. 3.

**Effect of pressure on the diffusion coefficient at constant temperature** The diffusion coefficient for the CO<sub>2</sub>-O<sub>2</sub> system at temperature 25°C and at pressures, 5, 10 and 20kg/cm<sup>2</sup> are:

7) F. Hutchinson *J. Chem. Phys.*, 17, 1081 (1949)

8) *Int. Crit. Tables*, 5, 62

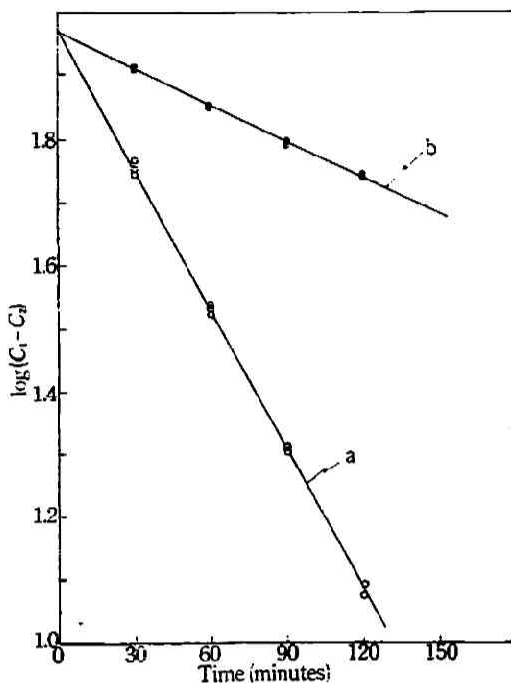

Fig. 3  $\log(C_1 - C_2)$  plotted against time at 25°C  
 a: CO<sub>2</sub>-H<sub>2</sub> system at 5 kg/cm<sup>2</sup>  
 b: CO<sub>2</sub>-O<sub>2</sub> system at 5 kg/cm<sup>2</sup>

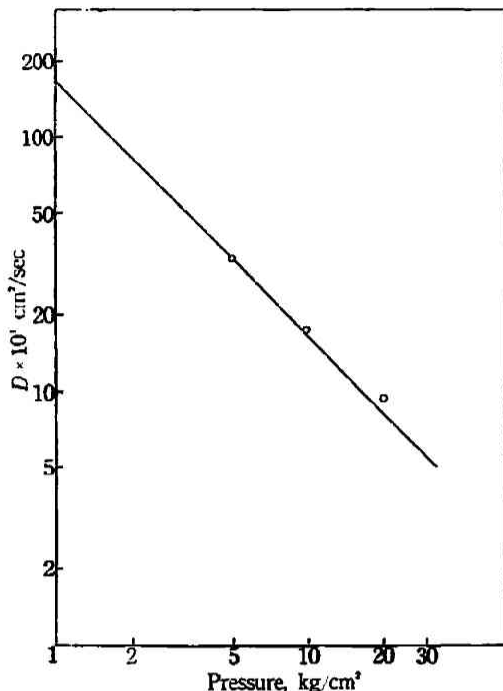

Fig. 4 Diffusion coefficient of CO<sub>2</sub>-O<sub>2</sub> system at 25°C plotted against pressure

Table 1 Diffusion coefficient of CO<sub>2</sub>-O<sub>2</sub> system  
 (cm<sup>2</sup>/sec × 10<sup>-2</sup>)

Pressure, kg/cm <sup>2</sup>	Temperature, °C		
	5	25	45
5	...	3.31	...
10	1.75	1.76	1.92
20	0.886	0.957	1.01

shown in Table 1.

In Fig. 4 the diffusion coefficient is plotted against pressure, where the solid line is theoretical and points are experimental. The plots, as shown in Fig. 5, of diffusion run at 30 kg/cm<sup>2</sup> show a curvature, so that the diffusion coefficient can not be obtained from the experiment.

**Effect of temperature on the diffusion coefficient at constant pressure** In order to study the effect of temperature on the diffusion coefficient, runs are performed under the conditions of 10 and 20 kg/cm<sup>2</sup> at 5°, 25°, and 45°C respectively. The results are presented in Table 1.

In Fig. 6, the values of logarithm of the diffusion coefficients are plotted against the reciprocal of the absolute temperature, which form nearly straight lines. The apparent temperature coefficients calculated from the slope of these straight lines, plotted  $\log D$  against  $1/T$  at 10 and 20 kg/cm<sup>2</sup>, are 890 cal/mole and 570 cal/mole respectively.

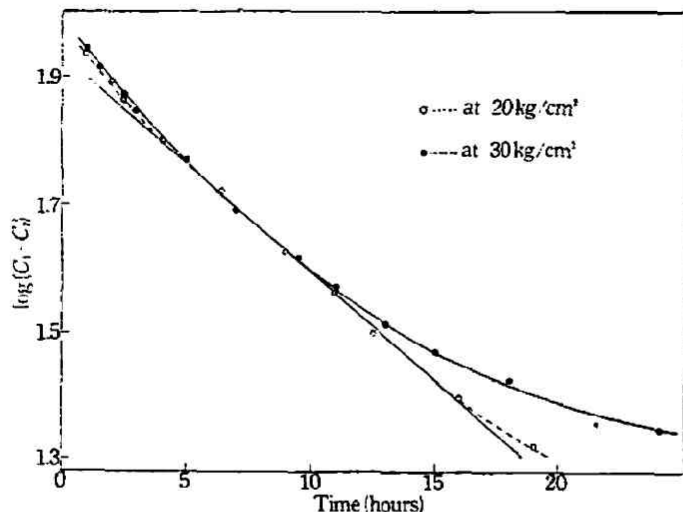

Fig. 5  $\log(C_1 - C_2)$  plotted against time at 25°C; System  $\text{CO}_2\text{-O}_2$

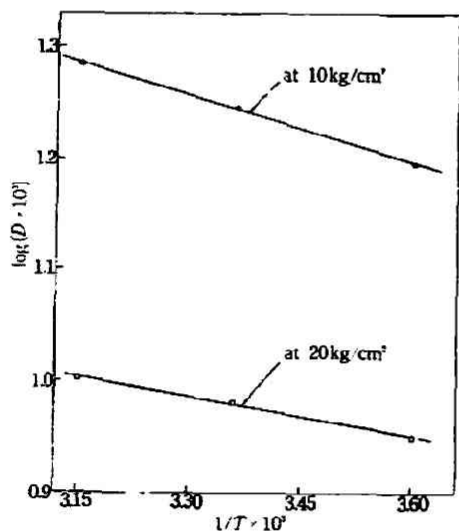

Fig. 6  $\log(D \times 10^3)$  plotted against  $1/T$  at constant pressures

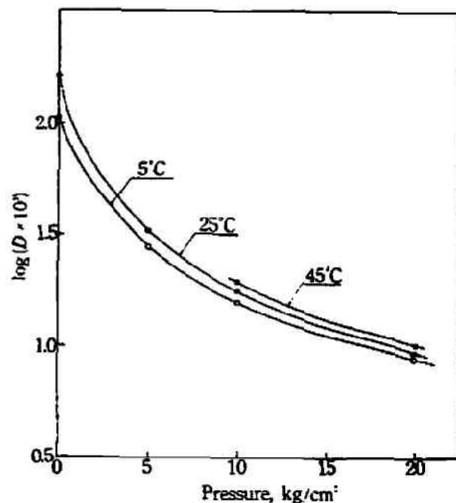

Fig. 7  $\log(D \times 10^3)$  plotted against pressure at constant temperatures

### Considerations

On the construction of diffusion cell The diffusion cell employed in the present investigation is of the same type as that used previously by H. G. Drickamer and his coworker. Their investigation show that the diffusion coefficient at above 28.6 atm can not be obtained because the plots of  $\log(C_1 - C_2)$  against time do not show a linear relation. In Fig. 5, the similar deviation from linearity is found in the present experiment and so the estimation of the slope is difficult to make above 30 kg/cm<sup>2</sup>. The reason for the deviation is not established, but as H. G. Drickamer's view the convection effects of opening the valve at the beginning of the experiment may lead to accelerate the diffusion rate. H. A. O'Hern and J. J. Martin reported the similar

tendency due to the diffusion path made of porous metal. When one of the cells having four drilled holes is used, the plots from the experiment show the deviation from linearity at above 25 atm, but in the case of the other cells the plots give straight lines at the same pressure. The reason is not elucidated either, but the same tendency is observed in the present experiment.

**On the effect of mixture composition** On this effect there are two opinions controverted by O. E. Meyer and by J. C. Maxwell. The first approximation given by D. Enskog for the diffusion coefficient is independent of composition, but this is no longer true in the second approximation.

J. O. Hirschfelder<sup>9)</sup> showed the following equation for the second approximation,

$$(D_{21}) = \frac{(D_{12})}{(1 - \Delta)} \dots\dots\dots(7)$$

where  $\Delta$  is a small quantity usually less than 0.03. This effect was examined in the experiment by H. G. Drickamer and his coworker.<sup>5)</sup> In the present experiment, the effect of composition can not be considered. On this respect, the investigation using radioisotope technique should be done in more details.

**On the effect of pressure** In order to elucidate the effect of pressure, the variation of temperature coefficient with pressure is considered. As mentioned above, the values of temperature coefficients decrease with pressure, and in this very respect the values of diffusion coefficients should increase with pressure. But, in fact, the diffusion coefficients decrease remarkably with pressure, being contrary to the effect of the change of the temperature coefficient. So it is considered that the pressure chiefly has effect upon the frequency term.

The authors have great pleasures in expressing their sincere thanks to the late Prof. R. Kiyama and Dr. H. Kinoshita for this investigation.

*The Laboratory of Physical Chemistry,  
Kyoto University*

9) J. O. Hirschfelder, *Chem. Rev.*, **44**, 205 (1949)