

Helen Slater Stokes

**Exploring the Optical Perception of Image
Within Glass**

A thesis submitted in partial fulfilment of the requirements of the Royal
College of Art for the degree of Doctor of Philosophy

Date: 1st February 2020



Helen Slater Stokes

**Exploring the Optical Perception of Image
Within Glass**

A thesis submitted in partial fulfilment of the requirements of the Royal College of Art
for the degree of Doctor of Philosophy

Date: 1st February 2020

Copyright Statement

This text represents the submission for the degree of Doctor of Philosophy at the Royal College of Art, London. This copy has been supplied for the purpose of research for private study on the understanding that it is copyright material and that no quotation from the thesis may be published without proper acknowledgment.

Abstract

Exploring the optical perception of image within glass

Within the contemporary world, 3D film and television imagery is at the cutting edge of visual technology, but for centuries we have been captivated by the creation of visual illusions/allusions that play with our perception of the world, from the auto-stereoscopic barrier methods pioneered in the late 17th century by the French painter G. A. Bois-Clair to the 'Op' art movement of the 1960s and, more recently, Patrick Hughes' 'reverse perspective' paintings.

By building on these new and old technologies I have extended my own practice, which engages with the 2D image as a 3D allusion/illusion in glass, by examining how this type of image can be created and perceived within glass. I have explored theories of optical perception in connection with the binocular recognition of depth and space, as well as kinetic clues to distance through motion parallax monitoring and assumptions about default linear perspective, light and inference within our personal schemata.

- 'Optical illusion' is used to mean an instance of a wrong or misinterpreted perception of a sensory experience; the distortion of senses revealing how the brain organises and interprets visual information; an individual's ability to perceive depth, 3D form and motion.
- 'Allusion' is used to imply a symbolic or covert reference.

My practical research focuses on the perceived creation of the 3D image within glass and explores the notion of glass as a facilitator in working with and challenging the themes of 3D image perception. I have particularly addressed artistic spatial illusionary methods, reverse perspective techniques, auto-stereoscopic image-based systems, parallax stereograms and lenticular print and lens technology.

Through building on my previous practice of working with multiple-layered images within cast glass, combined with more complex and scientific optical methods, I have explored the perception of the image by working with new and old 3D technologies in order to produce a body of work which examines this perception within glass.

During my research I have developed an original casting process, a vacuum-casting lost wax process for glass, in addition to producing an accurate industry standard lenticular glass lens. This research intends to provide a theoretical basis for new glass

Exploring the Optical Perception of Image Within Glass

working techniques, both within the glass artist's studio and in the commercial world of print, towards applications within architectural design, installation art and image-based artwork in general.

This thesis is therefore a summation of the research that I have undertaken over the past six years and an attempt to give substance to the ideas and references that have preoccupied my own investigations over that period.

I have structured the thesis into three themes: perspective; perception; and process but those three elements were never separate from each other and not only do they depend on each other, their purpose is, in some way, to combine in the creation of my finished pieces.

Contents

Copyright Statement.....	iv
Abstract	v
Acknowledgements	xiv
Author’s Declaration	xv
1. Introduction	1
1.1. Motivation	3
1.2. Aims	8
1.3. The Studio Glass Community	10
1.4. Research within The Kiln Formed Studio Glass Community	11
1.5. Research Methods	13
1.6. Overview of the Thesis.....	14
2. The Visual Perception of Objects and Space	16
2.1. The Human Eye.....	16
2.2. Perceived Vision.....	17
2.3. Monocular Optical Cues and Their Interpretation in Art.....	20
Light and Shadow.....	20
Atmospheric Perspective and Textural Gradient.....	22
Visual Interposition or Overlapping Cues.....	27
Relative Scale.....	29
Linear or Convergent Perspective	31
2.4. Gestalt Theory	38
Similarity Principle	40
Proximity Principle.....	40
Continuity or Continuation Principle.....	40
Figure and Ground Principle	41
Common Fate Principle.....	44
Closure Principle.....	44
2.5. Optical Art and Illusion	47
Trompe l’oeil	47
Anamorphosis	49
2.6. Optical Depth Perception	52
Accommodation	52
Convergence.....	52
Binocular Parallax	52
Monocular Movement Parallax.....	52
Double Vision in Art.....	53

3. Glass Artwork and Optical Perception	60
3.1. The Visual Characteristics of Glass.....	60
3.2. Transparency and the Image	63
3.3. Translucency and Abstraction	75
3.4. Geometric Perspective.....	80
3.5. Between Two and Three Dimensions.....	84
4. Technological Development of the Image	95
4.1. History of Multi-dimensional Imagery.....	95
4.2. Strand One - Stereoscopic - Two Dissimilar Images.....	98
4.3. Strand Two - Parallax Barrier Methods	100
4.4. Strand Three - Integral Images	103
4.5. The Holographic Image.....	106
5. Material Process.....	110
5.1. Introduction.....	110
5.2. The Image and Glass	111
Sandblasting.....	112
Underglaze Enamels	113
Silkscreen Printing	114
Digital Ceramic Transfer.....	115
Image Intensity and Transparency.....	118
5.3. The Reverse Perspective Illusion.....	119
5.4. The Commercial Lenticular Lens.....	125
Lens Types	126
The Industry-standard Acrylic Lenticular Lens.....	128
Lens Manufacture	128
The Focal Point of the Lens.....	130
5.5. Commercial Lenticular Image Printing.....	131
5.6. Interlacing an Image	131
5.7. Casting Techniques Towards Lenticular Lens Production.....	134
Vacuum Casting Glass	135
Kiln formed Lenticular Lens Tests	143
5.8. The Lenticular Image	145
6. The Work.....	147
6.1. Creating a Foreground Plane	147
6.2. Exploiting Perspective.....	149
6.3. Lenticular Artworks	152
6.4. More than the Sum of the Two Parts.....	158
7. Conclusion.....	163
7.1. Contribution to the Advancement of Knowledge	166
7.2. Areas for Further Development.....	167

Appendices.....	169
Appendix 1: Plates.....	169
Plate 1. Helen Slater Stokes <i>Treeline</i> (2016).....	169
Plate 2. Helen Slater Stokes <i>Geometric Perspective</i> (2017).....	170
Plate 3. Helen Slater Stokes <i>Focus</i> (2018).....	171
Plate 4. Helen Slater Stokes <i>Spheres I</i> (2015).....	172
Plate 5. Helen Slater Stokes <i>Virtual Landscape</i> (2018).....	173
Plate 6. Helen Slater Stokes <i>Blueprint</i> (2018).....	174
Plate 7. Helen Slater Stokes <i>Oculus</i> (2018).....	175
Plate 8. Helen Slater Stokes <i>Acuity</i> (2018).....	176
Plate 9. Helen Slater Stokes <i>Asymmetric Cone</i> (2019).....	177
Plate 10. Helen Slater Stokes <i>Symmetric Cone</i> (2019).....	178
Plate 11. Helen Slater Stokes <i>Asymmetric Vortex</i> (2019).....	179
Plate 12. Helen Slater Stokes <i>Breaking Ground</i> (2019).....	180
Appendix II: Practical Testing.....	181
A. The Image in Glass.....	181
A.1. Sandblasting.....	181
A.2. Painted Underglaze Enamel.....	181
A.3. Screen Printed Underglaze Enamel.....	182
A.4. Fusing Ceramic Transfers.....	182
A.5. Table of Result for Initial Image Testing.....	183
B. Ceramic Transfer Within Glass.....	184
B.1. Test firing 1.....	184
B.2. Test Firing 2.....	185
B.3. Test Firing 3.....	186
B.4. Double layer of Decal to intensify colour.....	188
B.5. Test Firing 5.....	189
B.6. Test Firing 6.....	190
B.7. Test Firing 7.....	191
B.8. Test Firing 8.....	192
C. Reverse Perspective Castings.....	193
C.1. Reverse Perspective Casting -Treeline.....	193
C.2. Reverse Perspective Casting - Geometric Perspective.....	194
D. Further Testing of Complex Ceramic Transfer Images in Glass.....	196
D.1. Sea Scapes - Photographic Decals.....	196
D.2. Photographic Decals - layered into castings – Test 1.....	197
D.3. Photographic Decals – layered into castings – Test 2.....	198
D.4. Screen Printed Image Within Fused Glass.....	199
D.5. Fusing Large Ceramic Transfers – Test 1.....	200
D.6. Fusing Large Ceramic Transfers - Test 2.....	201
D.7. Fusing Large Ceramic Transfers - Test 3.....	202
E. Lenticular Lens Fabrication.....	203
E.1. Lenticular Lens – Kiln Firing 1.....	203
E.2. Lenticular Lens – Kiln Firing 2.....	204
E.3. Lenticular Lens – Kiln Firing 3.....	205
E.4. Lenticular Lens – Kiln Firing 4.....	206
E.5. Lenticular Lens - Kiln Firing 5.....	207
E.6. Industry Standard Lenticular Lens Calibration Test Sheet.....	208
F. Vacuum Casting Tests.....	209
F.1. Priory Casting Ltd - Metal Casting Equipment.....	209
F.2. Mould Preparation.....	213
F.3. Glass Flow Testing.....	214
F.4. Vacuum Cast Glass Excavation and Results.....	215
F.5. Burnout, Melt and Annealing Firings for Vacuum Casting.....	218
Casting Using Gaffer Glass.....	218
Casting Using Bullseye Casting Crystals.....	219
Casting Using Glasma - Furnace Glass.....	219

Exploring the Optical Perception of Image Within Glass

G. The Lenticular Interlacing of an Image	220
Bibliography	224
Text Sources.....	224
Films.....	231

Figures

Figure 1. Gaspar Antoine de Bois-Clair Double Portrait of King Frederick IV and Queen Louise of Mecklenburg-Güstow of Denmark (c. 1654)..... 1

Figure 2. Bridget Riley *Movement in Squares* (1961) 1

Figure 3. Tim Tate *Vitruvian Visions* (2016) 2

Figure 4. Reinoud Oudshoorn *B-16* (2016) 2

Figure 5. Blog Post: Chemical Garden 4

Figure 6. Helen Slater Stokes *Journey* (2007)..... 5

Figure 7. Helen Slater Stokes *Winter's Evening* (2017) 6

Figure 8. Helen Slater Stokes *Winter's Evening* (Detail) (2017)..... 7

Figure 9. Diagram of the Eye 16

Figure 10. Depth from Shading..... 21

Figure 11. M. C. Escher *Convex and Concave* (1955) 21

Figure 12. Stan Prokopenko Example Images, The Illusion of depth, Contrast, Aerial Perspective and Form (April 2013)..... 22

Figure 13. Caspar David Friedrich *The Watzmann* (1824–25) 24

Figure 14. M. C. Escher *Waterfall* (1961)..... 25

Figure 15. Joseph Mallord William Turner *Distant View of Coblenz and Ehrenbreitstein* (c. 1839)..... 26

Figure 16. Mariele Neudecker *I Don't Know How I Resisted the Urge to Run* (1998) 26

Figure 17. Overlapping Principle Diagram 28

Figure 18. Chauvet Cave (c. 30,000 B.C.)..... 28

Figure 19. Sandro Botticelli *Madonna of the Magnificat* (1481) 29

Figure 20. Gustave Caillebotte *Paris Street: A Rainy Day* (1877) 30

Figure 21. René Magritte *Personal Values* (1952) 30

Figure 22. Mario Ponzo *A version of the Ponzo Illusion* (originated in 1911) 32

Figure 23. Vintage *Ames Room Illusion* 32

Figure 24. Diagram of the True and Apparent Position of a Person in an *Ames Room* and the Shape of That Room..... 32

Figure 25. Josef Albers *Structural Constellation* (c. 1950)..... 33

Figure 26. Pompeian Mural of the Pageant of Orestes, 2nd century A.D..... 34

Figure 27. Diagram Demonstrating Filippo Brunelleschi's Perspective Technique from a Lost Painting of the Battistero di San Giovanni. 35

Figure 28. Piero della Francesca *The Flagellation of Christ* (late 1450s) 36

Figure 29. Patrick Hughes *Superduperperspective* (2002) 37

Figure 30. James Turrell *Afrum I (White)* (1966)..... 38

Figure 31. Ronald C. James *Dalmatian Dog*..... 39

Figure 32. James' Photograph..... 39

Figure 33. The Principle of Similarity 40

Figure 34. The Gestalt Principle of Proximity 40

Figure 35. Steve Bradley *Continuity Principle Diagram* (2010)..... 41

Figure 36. Good *Continuation Principle Diagram* 41

Figure 37. Edgar John Rubin *Rubin's Vase* (1915)..... 42

Figure 38. Esther Stocker *O.T* (2016)..... 42

Figure 39. M. C. Escher *Angel-Devil (No. 45)* (1941)..... 43

Figure 40. M. C. Escher *Lizard (No. 25)* (1939)..... 43

Figure 41. M. C. Escher *Sky and Water I* (1938)..... 44

Figure 42. Common Fate Diagram 44

Figure 43. Closure Principle Diagram..... 45

Figure 44. *Necker Cube* 45

Figure 45. *Necker Cube* 45

Figure 46. Jane Harris *Study for Moment of Alignment* (2014)..... 46

Figure 47. Redacted -Victor Vasarely *Gestalt 4* (1970) 47

Figure 48. Flemish School *A Boy Looking through a Casement* (c. 1550–60) 48

Figure 49. Samuel van Hoogstraten *A Peep Show with Views of the Interior of a Dutch House* (c. 1650s)..... 49

Figure 50. Hans Holbein the Younger *The Ambassadors* (1533) 49

Figure 51. Thomas Shashan Photograph of The Ambassadors: 50

Figure 52. Victor Vasarely *0519-Bayna* (1964)..... 51

Figure 53. Helen Slater Stokes *Field View* (2019) 54

Figure 54. Paul Cézanne *Still Life With Apples* (c. 1878)..... 55

Figure 55. Michelangelo Merisi da Caravaggio *Basket of Fruit* (1597–1602) 56

Figure 56. Pablo Picasso *Portrait of Ambroise Vollard* (1910)..... 57

Figure 57. Evan Walters *Stout Man with Jug* (c. 1936) 58

Figure 58. Jeffrey Sarmiento *Natives* (2002)..... 64

Figure 59. Jeffrey Sarmiento *Triple Self Portrait* (2007)..... 66

Figure 60. Jeffrey Sarmiento *Encyclopedia (Volumes)* (2010–13) 67

Figure 61. Jeremy Lepisto *Building Up* (2008)..... 68

Figure 62. Antony Gormley *Matrix V* (2017)..... 69

Exploring the Optical Perception of Image Within Glass

Figure 63. Jeremy Lepisto <i>Reach</i> (2011).....	70
Figure 64. Wilfried Grootens <i>Anemon</i> (2015).....	71
Figure 65. Wilfried Grootens <i>Where the Shark Bubbles Blow</i> (Detail) (2012).....	73
Figure 66. Wilfried Grootens <i>Dream Carrier</i> (2017).....	73
Figure 67. Wilfried Grootens <i>Small Cosmic Efflorescence 1</i> (2016).....	74
Figure 68. Karlyn Sutherland <i>Latheron House, Caithness</i> (2016).....	75
Figure 69. Karlyn Sutherland <i>Latheron House, Caithness</i> (2016) (Detail).....	76
Figure 70. Jessica Loughlin <i>Unfolding Continuum</i> (2012).....	77
Figure 71. Jessica Loughlin <i>Receptor of Light Opera Unica, Adelaide</i> (2016).....	79
Figure 72. Jeffery Sarmiento <i>Estate</i> (2012).....	81
Figure 73. Jeffery Sarmiento <i>Estate</i> (Detail) (2012).....	82
Figure 74. Jeffery Sarmiento <i>Centre</i> (2012).....	82
Figure 75. Karlyn Sutherland <i>Scrabster, Caithness (2)</i> (2017).....	83
Figure 76. Reinoud Oudshoorn <i>B-10</i> (2010).....	85
Figure 77. Reinoud Oudshoorn <i>B-11</i> (2011).....	86
Figure 78. Anna Gay <i>Abstract-art-blur</i> (2011).....	87
Figure 79. Reinoud Oudshoorn <i>B-14</i> (2014).....	88
Figure 80. Olafur Eliasson <i>Orbit 2</i> (2017).....	89
Figure 81. Olafur Eliasson <i>Orbit 2</i> (2017).....	90
Figure 82. Olafur Eliasson <i>Your Trust</i> (2014).....	92
Figure 83. Olafur Eliasson <i>Your Fading Self (West)</i> (2013).....	93
Figure 84. Larry Bell <i>First & Las'</i> , installation view (1989).....	94
Figure 85. Gaspar Antoine de Bois-Clair <i>Double Portrait of King Frederick IV and Queen Louise of Mecklenburg-Güstow of Denmark</i> (c. 1654).....	96
Figure 86. Diagram of Charles Wheatstone's Stereoscope (1838).....	97
Figure 87. Louis J. M. Daguerre.....	97
Figure 88. Examples of Sir David Brewster's Stereoscopes (1849).....	98
Figure 89. Example of an Oliver Wendell Homes-type, Stereoscopic Viewer (c. 1905).....	99
Figure 90. 3D Film Footage Still (1954) <i>The Creature from the Black Lagoon in 3D</i>	99
Figure 91. Paul Bourke <i>Autostereoscopic Lenticular Images</i> (1999).....	100
Figure 92. Clarence W. Kanolt <i>Parallax Panoramagram Camera</i> (1918).....	102
Figure 93. Herbert Ives <i>Drawing of Large Lens camera Method</i> (1930).....	103
Figure 94. <i>An Integral Fly's-eye Lens Array Greatly Enlarged</i> (2003).....	104
Figure 95. <i>Look Magazine</i> featured <i>Parallax Panoramagram</i> (1964).....	105
Figure 96. <i>Look Magazine 2nd</i> featured <i>Parallax Panoramagram</i> (1964).....	105
Figure 97. Lannes de Montebello <i>Possibly the First Integram Taken Integram photo of Baby Alice Globus</i> (c. 1985-86).....	106
Figure 98. Lannes de Montebello <i>with the CrystalChrome Camera</i> (c. 1985).....	106
Figure 99. <i>Holographic Setup Diagram</i>	107
Figure 100. <i>Kate Moss Hologram</i> (August 2011).....	108
Figure 101. <i>Princess Leia Hologram Could Be a Reality</i>	108
Figure 102. <i>Test image 1</i>	112
Figure 103. <i>Fused digital transfer sandwiched between 2 sheets of glass</i>	116
Figure 104. <i>Front face view of a test casting</i>	116
Figure 105. <i>Firing Schedule 1</i>	117
Figure 106. <i>Firing Schedule 2</i>	117
Figure 107. <i>Firing Schedule 3</i>	117
Figure 108. <i>Laminated glass test with digital decal transfer</i>	119
Figure 109. Helen Slater Stokes <i>Treeline</i> (2017).....	120
Figure 110. <i>Digital design from the internal form</i>	120
Figure 111. Helen Slater Stokes <i>Treeline</i> (2016).....	121
Figure 112. Helen Slater Stokes <i>Geometric Perspective</i> (2017).....	122
Figure 113. Helen Slater Stokes <i>Geometric Perspective</i> (Detail) (2017).....	123
Figure 114. Helen Slater Stokes <i>Geometric Perspective</i> (2017).....	124
Figure 115. Rufus Butler Seder <i>Large Galloping Horse</i>	125
Figure 116. Zsuzsanna Korodi <i>Grid III</i> (2017).....	126
Figure 117. <i>Diagram of a triangular formation lenticular</i>	126
Figure 118. Jeffrey Sarmiento <i>Confluence</i> (2016) & Figure 119. Jeffrey Sarmiento <i>Confluence</i> (2016).....	127
Figure 120. <i>Lenstar Lenticular Ltd Diagram explaining the angle of view for 3D and animation lenticular lenses</i>	129
Figure 121. Jee Hoon Sim et al <i>Schematic diagram showing the relationship between the focal length and crosstalk</i> (2018).....	130
Figure 122. <i>Lenticular lens and image interlace diagram</i>	133
Figure 123. <i>Shetara Edden Ring waxes setup on a wax tree ready for casting</i>	136
Figure 124. <i>Base board with wax reservoir (a) and casting flask in position (b)</i>	137
Figure 125. <i>Mould, post investment pour</i>	137
Figure 126. <i>Furnace crucible or Salamander and the crucible being heated in the furnace</i>	138
Figure 127. <i>Industrial vacuum chamber</i>	139
Figure 128. <i>Casting mould slotted into vacuum chamber and sealed with fire putty</i>	139
Figure 129. <i>Molten metal being drawn into the mould under vacuum</i>	140

Exploring the Optical Perception of Image Within Glass

Figure 130. Vacuum cast moulds	140
Figure 131. Vacuum chamber.....	141
Figure 132. Vacuum cast soda-lime glass tests.....	142
Figure 133. Helen Slater Stokes <i>Focus</i> (2018).....	148
Figure 134. Andrei Rublev <i>Annunciation</i> (1405).....	149
Figure 135. Helen Slater Stokes <i>Treeline</i> (2016).....	151
Figure 136. Spheres rendered in Rhino 3D software.....	152
Figure 137. Spheres image after digital interlacing.....	153
Figure 138. Helen Slater Stokes <i>Oculus</i>	153
Figure 139. Helen Slater Stokes <i>Acuity</i>	154
Figure 140. Landscape pen drawing.....	157
Figure 141. Digitally interlaced version of this landscape composition.....	157
Figure 142. <i>Grid Series: Asymmetric Cone and Asymmetric Vortex</i> (2019).....	158
Figure 143. Asymmetric design.....	159
Figure 144. Symmetric design.....	159
Figure 145. Helen Slater Stokes <i>Asymmetric Vortex</i> (2019).....	160
Figure 146. Helen Slater Stokes <i>Asymmetric Cone</i> (2019).....	161
Figure 147. Helen Slater Stokes <i>Symmetric Cone</i> (2019).....	161
Figure 148. Helen Slater Stokes <i>Breaking Ground</i> (2019).....	162
Plate 1.....	169
Helen Slater Stokes <i>Treeline</i> (2016).....	169
Plate 2.....	170
Helen Slater Stokes <i>Geometric Perspective</i> (2017).....	170
Plate 3.....	171
Helen Slater Stokes <i>Focus</i> (2018).....	171
Plate 4.....	172
Helen Slater Stokes <i>Spheres I</i> (2015).....	172
Plate 5.....	173
Helen Slater Stokes <i>Virtual Landscape</i> (2018).....	173
Plate 6.....	174
Helen Slater Stokes <i>Blueprint</i> (2018).....	174
Plate 7.....	175
Helen Slater Stokes <i>Oculus</i> (2018).....	175
Plate 8.....	176
Helen Slater Stokes <i>Acuity</i> (2018).....	176
Plate 9.....	177
Helen Slater Stokes <i>Asymmetric Cone</i> (2019).....	177
Kiln formed glass, ceramic transfer, steel. 41 x 41 x 6.5cm.....	177
Plate 10.....	178
Helen Slater Stokes <i>Symmetric Cone</i> (2019).....	178
Plate 11.....	179
Helen Slater Stokes <i>Asymmetric Vortex</i> (2019).....	179
Plate 12.....	180
Helen Slater Stokes <i>Breaking Ground</i> (2019).....	180

Acknowledgements

This thesis has been produced with the support of a large number of people. I would like to thank them all for their generosity with their time and help, without which I could not even have contemplated, let alone completed, this research.

Firstly, I must thank my husband Neil, without whom I would never have had the confidence to consider this research. His constant support and positivity has allowed me to pursue my passion and to immerse myself within my work. And also my twin sister Ann, who has always convinced me that anything is possible, with application and hard work.

I am very grateful to my supervisors Martin Smith and Heike Brachlow at the Royal College of Art, who have guided me through both the academic and conceptual aspects of this research, providing enthusiastic expert advice, motivation and inspiration over the last six years.

Thanks also goes to Mark Taylor, Sales Manager at Tribal 3D, for many insightful practical discussions and an unsurpassable wealth of lenticular knowledge and advice. I must also thank Richard Henshaw, from Priory Castings Ltd, and Clive Payne, from Clive Payne Antiques and Restoration, for all their ingenious practical support regarding the project.

And finally, I'd like to thank Trev and Drisc Wardle, at Two Faces Design, for their help in pulling the thesis together.

Thank you

Author's Declaration

1. During the period of registered study in which this thesis was prepared the author has not been registered for any other academic award or qualification.
2. The material included in this thesis has not been submitted wholly or in part for any academic award or qualification other than that for which it is now submitted.

Helen Stokes 2020

1. Introduction

Within the contemporary world of 3D film and television, virtual imagery is at the cutting edge of visual technology, but for centuries we have been captivated by the creation of visual illusions that play with our perception of the world, from the auto-stereoscopic barrier methods (Figure 1) pioneered in the late 17th century by French painter G. A. Bois-Clair to the 'Op' art movement of the 1960s (Figure 2), and more recently Tim Tate's glass sculptures (Figure 3) and the glass perspective works of Reinoud Oudshoorn (Figure 4). Throughout history we have been intrigued by these challenges to our perception of an image. This interest is particularly relevant in contemporary society. Today we have become captivated by rapid technological developments and there is heightened interest in the 'virtual' world, 3D film, 3D television technology, 3D gaming experiences and augmented reality.¹ These complex optical illusions² bring a spatial, three-dimensional element to what were previously two-dimensional media; making film, television and the virtual rendering of this fabricated world more immersive.



Figure 1.
Gaspar Antoine de Bois-Clair Double
Portrait of King Frederick IV and
Queen Louise of Mecklenburg-Güstow
of Denmark (c. 1654)
Oil on wood strips. 39.4 x 32.4cm

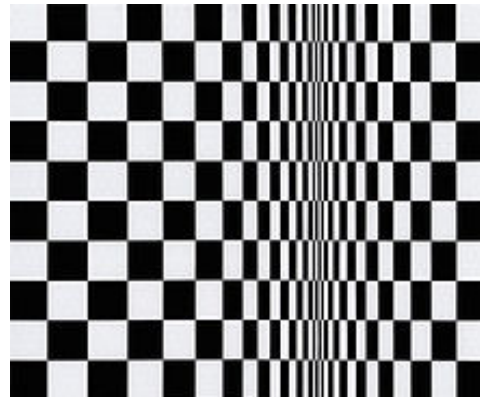

Figure 2.
Bridget Riley *Movement in Squares* (1961)
Tempera on hardboard. 123.2 x 121.2cm
© Bridget Riley 2020. All rights reserved

¹ Virtual (within computing) – Not physically existing as such but made by software to appear to exist. ('Virtual', Lexico <https://www.lexico.com/en/definition/virtual>)

² 'Optical illusion' - something that tricks your eyes and makes you think you see something that is not really there or see it differently from how it really is. ('Optical illusion', *Cambridge Dictionary* <https://dictionary.cambridge.org/dictionary/english/optical-illusion>)

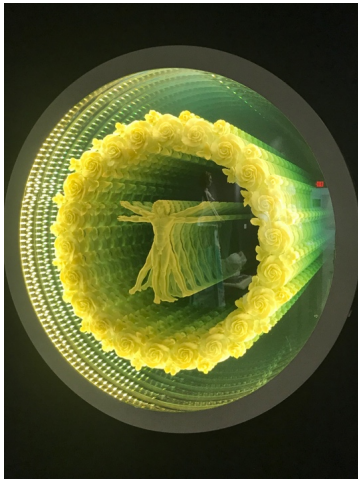

Figure 3.
Tim Tate *Vitruvian Visions* (2016)
Cast glass, plate glass, mirror, steel,
LED lighting. 70 x 70 x 10.2cm.
By kind permission of the artist

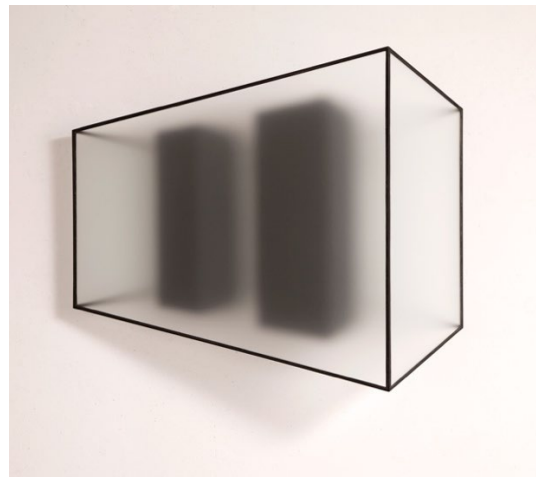

Figure 4.
Reinoud Oudshoorn *B-16* (2016)
Frosted glass and iron glass, 64 x 77 x 25cm.
By kind permission of the artist

The understanding of how we perceive three-dimensional depth, via our binocular vision, is not new. As early as the 4th century BC Greek mathematician Euclid was credited by some with the discovery of the principles of binocular vision. But today, with the interest in 3D virtual technology, the launch of glasses-free 3D televisions, virtual reality headsets and now augmented reality, the process of working with binocular vision, imagery and kinetics to create the illusion of 3D depth is being explored further than ever before. It is also important to note that this is a phenomenon which isn't restricted to the entertainment and leisure industry, but is technology that is reaching into research, surveillance, inspection, process control and a wide variety of medical applications.³

Within this research into perceived three-dimensional depth, the image is only half the story. The other element is glass and its optical properties.

Glass as a material has a wealth of illusionistic qualities. It has the ability to reflect,⁴ transmit and refract⁵ light and, within the context of the image, the visual qualities of glass enable images to become magnified, reduced, inverted and diffused in appearance. Most people are familiar with some of the optical characteristics of

³ Paul Dempster. 3D Imaging Technology Changing the Way We Look at Things. (Nov 1st 2011) <https://www.techbriefs.com/component/content/article/tb/features/articles/11932> [Accessed 29/03/19].

⁴ Reflection – The return of light, heat, sound or energy. A reflection is also an image seen in a mirror or other shiny surface. ('Reflection', *Cambridge Dictionary*, <https://dictionary.cambridge.org/dictionary/english/reflection>)

⁵ Refraction –The fact of light or sound being caused to change direction or to separate when it travels through water, glass etc. ('Refraction', *Cambridge Dictionary*, <https://dictionary.cambridge.org/dictionary/english/refraction>)

glass, as listed above, but it is its transparency which enables us to view framed imagery within our homes or look out of windows to view the outdoor world which is most familiar to us. This symbiotic relationship between glass and a captured image or scene, as a device to view something through, allowing us to look into a space, has existed for centuries; records evidence the existence of Roman cast glass picture windows as early as 100 A.D. Initially, however, this kind of glass was not created for its ability to allow the viewer to see through it, but more as a defence to protect the interior from the elements. The transparency of glass, through the refinement of manufacturing and production processes, has now become its most recognisable quality.

This connection between glass and the capturing of scenes, landscape and spaces which gives the viewer the sense of looking into or out at another world is something that has always fascinated me. Glass allows the framing of views via windows and the capturing of scenes or spaces within paperweights, snow globes and digital technology.

1.1. Motivation

I have been a kiln formed glass practitioner for the last twenty-three years, since completing my Master's degree at the Royal College of Art. Part of this practice has been making and selling glasswork, via galleries, and working to public and private commission. It has been a varied practice, and this knowledge, in addition to teaching, has informed this body of research.

Whilst making glasswork over the last ten years I had begun to focus on drawings in glass and how these could start to communicate spatial depth. This notion of capturing perceived spatial depth within glass has always interested me, ever since I gazed into crystal gardens grown in glass jam jars as a child. (see Figure 5)



Figure 5.
Blog Post: Chemical Garden
Posted 1/27/2018, <https://busy.org/@aliabdullahsaleh/chemical-garden>

I had been fascinated by watching these miniature worlds grow behind the distortion and magnification of the glass, and it was these forms or images behind or within glass that have always captured my imagination and interest. These surreal, watery worlds held a reference to artefact and capture, through subconscious associations to conservation and preservation. They were also ethereal and dreamlike, appearing otherworldly and poetic. This visual reference to glass as a preservative material encasing moments, colour, movement, bubbles and imagery is something I have drawn upon within my work in my attempt to recreate remembered places from my past via virtual spaces within the glass. This PhD research has given me the opportunity to investigate new technical possibilities and to examine how we perceive an image within this optical material.

Initial iterative techniques, which created the impetus for this research, were based on the overlapping of similar images. This effect of creating essentially 'double vision', or what is known medically as diplopia,⁶ was simply the result of overlaying images which had been fired onto glass. I didn't know at that point why these pieces started to be effective optically in conveying a sense of depth, but I became intrigued by this effect. After extensive systematic ocular testing, I began to make outdoor pieces using this process. (See Figure 6)

⁶ Double vision (diplopia) is when you look at one object but can see two images. It may affect one eye or both eyes. ('Double vision', Conditions, NHS, <https://www.nhs.uk/conditions/double-vision/> [Accessed 21/06/18])



Figure 6.
Helen Slater Stokes *Journey* (2007)
Toughened and laminated float glass. 230cm diameter x 145cm high. Commissioned by the
Oxford Radcliffe Hospitals Trust for The Churchill Hospital, Oxford

These life-sized outdoor pieces, commissioned by the Oxford Radcliffe Hospitals NHS Trust in 2007 for the Churchill Hospital, Oxford, exploited the overlapping of different images to create what is perceived as a partially animated three-dimensional drawing. As mentioned above, at the time I didn't know why this slight disparity of image managed to communicate a sense of depth, but I assumed it was related to our binocular vision - in which each eye takes in a different viewpoint and these are then fused together and rationalised by the brain to create one perceived image of our surroundings.

Binocular disparity⁷ is one of the cues that allow the brain to calculate depth and distance. In very simple terms, if the images taken in by each eye are very different, the object is close to the viewer, and if they are almost the same, the object is further away.

⁷ 'Binocular Disparity' – The slight difference between the right and left retinal images. When both eyes focus on an object, the different position of the eyes produces a disparity of visual angle and a slightly different image is received by each retina. The two images are automatically compared and, if sufficiently similar, are fused, providing an important cue to depth perception.

Exploring the Optical Perception of Image Within Glass

It is only through this research that I now have a greater understanding of how this very basic approach to the creation of an image works optically.

Within my studio practice, in parallel with making the outdoor works, I was also using drawn imagery in cast glass pieces for a gallery context. My smaller-scale, kiln formed designs utilised a sgraffito⁸ glass frit technique, and within these I also began to exploit this 'double image' effect. These works were further refined by removing the direct drawing, initiated in the sgraffito process, and replacing it with individually altered silkscreen prints of the drawings to increase accuracy.

This work was well received by galleries and public alike, and this is a methodology that I have been working with over the last ten years. (See Figure 7)

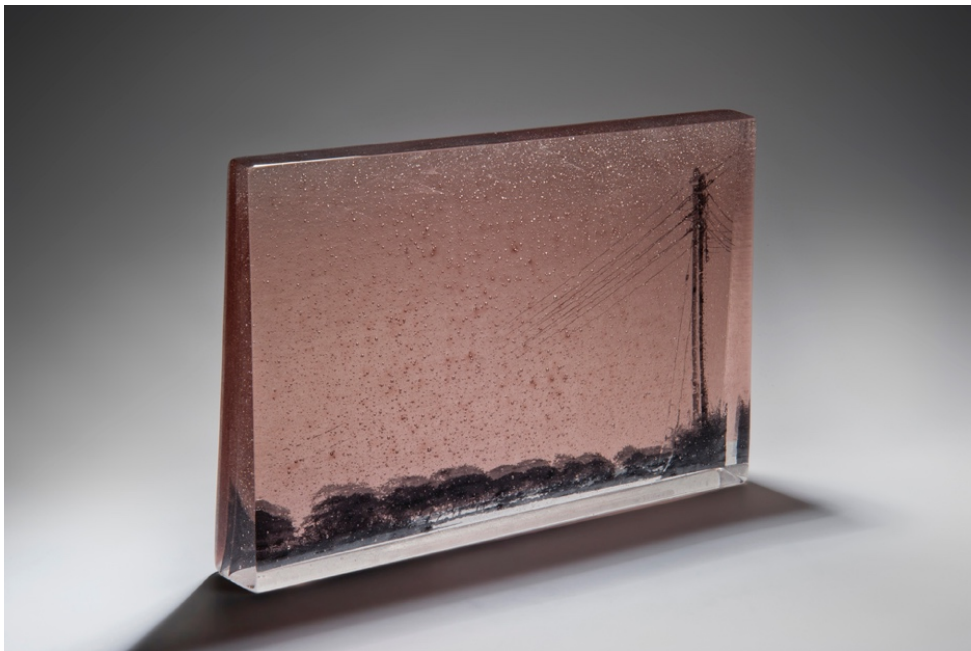

Figure 7.
Helen Slater Stokes *Winter's Evening* (2017)
Cast glass, glass frit and under glaze.
42 x 30 x 5cm. Photography by Ester Segarra

For example, the image within *Winter's Evening* is made up of two different drawings that are floated within the casting. (Figure 8). This use of a double image, which has slight variations and additions, allows the viewer to look around the flat illustration whilst also emphasising binocular disparity.

⁸ *Sgraffito*, (Italian: 'scratched'), in visual arts, a technique used in painting, pottery and glass which consists of putting down a preliminary surface, covering it with another, and then scratching the top layer in such a way that the pattern or shape that emerges is of the colour beneath it. .



Figure 8.
Helen Slater Stokes *Winter's Evening (Detail)* (2017)
Cast glass, under glaze. 35 x 25 x 5cm

This cast glass piece offers the viewer two almost identical images, which the brain recognises as a subtle reference to the two images recorded by the eyes. Although not a punchy three-dimensional illusion, it does give a subtle animation and three-dimensional depth to the image within the glass casting. The optical properties of the polished glass surface also add confusion to the perceived depth, as the positioning of the images within the glass is ambiguous when viewing the piece from the front.

As I created these two-dimensional drawings I was aware that they could only offer one view, one image, which both eyes recorded identically. So here, if traditional illustrative methods were adopted, the illusionistic devices of shadow, various types of perspective, relative size, tonality and texture would have to be used to communicate visual depth. This was something that I had been teaching about in my role as a Foundation Art & Design tutor for 10 years. But looking at my own work, I realised that something different was happening. These works had very little tonal gradation; in fact, the images are solid flat silhouettes, perspective is hardly employed and the relative scale of familiar objects was only adopted in order to create a convincing composition. In fact, none of the prerequisite techniques used to communicate spatial depth on the pictorial plane were being exploited.

At this point I realised that this technique could be pushed further, and I wanted to understand what was happening optically so that this could inform the extension of my practice. It was this notion, and the apparent possibilities within depth perception, that created the agency for this body of research.

1.2. Aims

The fundamental aim of this research was to push the boundaries of how a single or multiple image could be perceived in glass. In doing so I created a spatial reference within the glass that increased the perceived visual depth and three-dimensional intensity of the two-dimensional image by extending the image beyond the physical boundaries of the glass form. But rather than exploring moving image technology or the digital screen-generated hologram, my parameters were to create this illusionistic image using an analogue approach. The premise for the success of this illusion had to reside with the viewer and their personal perception of the space within. As the production of this research was carried out within the studio glass environment, not in an industrial context, I also wanted the resulting works, in their final incarnation, to be non-digital. Specifically, these glass pieces should be objects

rather than video, projections or light illusions. This creates clear synergies with my own practice, positioning the work within the tradition of studio glass art.⁹

With this in mind, it is important to establish that my aim was to devise a new methodology that specifically addressed how a two-dimensional image can be understood as a three-dimensional space in glass, rather than focusing predominantly on the content of that image. It is for this reason that, although initial testing required the use of geometric and mimetically-based images, the imagery adopted for the purposes of this research serves the function of illustrating the spatial capabilities of the process, rather than conveying its own conceptual language.

Key aims for this research were as follows:

- To analyse the mechanics of visual perception, data intake and processing, in order to gain a further understanding of optical perception.
- To investigate contemporary and historical visual techniques which use the image to create three-dimensional spatial illusions. Then to explore and extend their application in glass.
- To use the creative aims of the research to provide a context for further testing and the development of glasswork which pushes the perceived visual capabilities of the image combined with glass, thus facilitating an expansion of the perceived depth and three-dimensional intensity of the image.
- The development of a glass process to fabricate a lenticular lens, based within a studio glass environment.
- The development of a process to create and calibrate an image to this glass lens which allows the viewer to perceive a greater spatial reference within this image when both lens and image are combined.

The initial impetus for this research was a desire to expand the visual language of an image in glass, to allow the optical qualities of this material to do more than simply provide a window on the image.- to impact and supercharge its three-dimensional

⁹ Studio Glass Art: art glass produced by an independent artisan in the studio. ('Studio glass', *Dictionary.com*
<https://www.dictionary.com/browse/studio-glass> [accessed 21/10/2017])

perception. The context for this research was the glass studio environment, in order to offer an original contribution of knowledge to the wider community of glass artists.

1.3. The Studio Glass Community

To give context to this research it is important to recognise the setting for this new contribution to knowledge and the criteria which this backdrop affords.

The studio glass community as we know it today was founded in what became known as the Studio Glass Movement. The definition of studio glass is as follows:

Studio glass is art glass produced by an independent artisan in the studio.¹⁰ Within contemporary studio glass, the range of practices and approaches can also be expanded into functional design, installation and architectural applications.

As early as the 1870s Émile Gallé (1846-1904), a French glass designer, had started to change the perception of glass as a creative medium. Following fine art painters and sculptors he began to sign his works. Along with Gallé, factories such as Orrefors in Sweden, Lalique in France and Tiffany in the United States began producing one-off pieces, although they continued to be better known for their production wares. Finally, in the 1960s, two Americans, the glass artist Harvey Littleton and the glass research scientist Dominick Labino, designed a small, inexpensive furnace for blowing glass, and this allowed artists to begin to work with this material for the first time outside a factory setting¹¹.

In the UK, Samuel J Herman (b.1936), whilst working at the Royal College of Art, was quoted to have [...] not only facilitated and developed the revolutionary techniques pioneered by Littleton and Labino but also brought about a new aesthetic approach.

This new accessibility to the material allowed a more experimental and creative approach to working with the medium and the adoption of varied technical processes which were not the premise of factory production.¹²

¹⁰ 'Studio Glass', Dictionary. Com, available at: <https://www.dictionary.com/browse/studio-glass>, [Accessed 25/11/19]

¹¹ 'Met Museum Bulletin, Modern Art', *Metropolitan Museum of Art, New York* <https://www.metmuseum.org/pubs/bulletins/1/pdf/3269174.pdf.bannered.pdf> [Accessed 20/07/19]

¹² Corning Museum of Glass, *The American Studio Glass Movement*, Published on October 5, 2011. Published on October 5, 2011. <https://www.cmog.org/article/american-studio-glass-movement> [Accessed 10/03/19]

Studio glass is a material-based practice which involves an iterative development of work using tacit knowledge. This movement was founded as a departure from the industrial manufacture of glass and its processes and is heavily based on the individual studio. As a result, small studios and workshops create glass pieces by using adapted industrial processes. The types of techniques that can be used within a studio glass practice range from blown and flame-worked glass to kiln formed, cast, slumped and fused glass, with the addition of cold working and finishing and engraving. These are unique artisan glassworks, which celebrate the artists' subjective creativity and draw on an intuitive and tacit working knowledge of the material. Within the context of this research the intention was to employ processes common to these small studio-based practices and, in doing so, to work in an intuitive way with the material whilst drawing upon empirical knowledge. This methodology allows for the cyclical iterative evaluation and development of work which is reflective and adaptable, a core principle within this community of studio glass practitioners.

1.4. Research within The Kiln Formed Studio Glass Community

All forms of art and design now yield strong research possibilities and the kiln formed area within Studio Glass is no exception. Here the material, techniques and concepts continue to move creative outputs forward, building upon previous knowledge and research, to create innovative new outcomes.

Therefore, in order to reference the context in which my own research sits, I aim to illustrate this innovation by briefly discussing the work of five contemporary researchers within kiln formed glass.

The material qualities of glass are often what captivate an artist, motivating them to pursue research, as in my own project. The first of this type of research that I came across was research by Shelley James, which exploited the material characteristics of glass in order to examine spatial interpretation within the material. This was research that resonated with my interest in glass's ability to confuse and confound our spatial expectations. But, unlike this project, James's work focused on the intangible interpretation of space within glass. The lack of internal edges, texture or shadows within glass creates incomprehensible illusions of space within the mind of the viewer, as the conventions used by the brain to perceive and interpret what we see are suddenly absent. On hearing about this research, at *Parallels and Connections*, a Sunderland Universities Glass conference in 2012, I began to review my practice and formulate my own notions relating to perception and glass.

The material characteristics of glass are also analysed in Heike Bracklow's research entitled *Shaping Colour: Density, Light and Form in Solid Glass Sculpture*. Examining the material's ability to transmit and absorb light, she investigates the relationship between transparent colour and volume. Within this body of work Bracklow originated methods to produce transparent coloured glass in a kiln, creating bespoke transparent coloured glasses, whilst examining how these colours translated through a range of formal distortions. Interestingly, as in my project, this research was firmly set within the studio glass environment, offering alternatives to industrially manufactured coloured glasses through techniques and equipment accessible to a kiln formed studio glass maker.

As happened during the inception of the Studio Glass movement, other researchers have looked beyond the glass studio, towards new innovations within industrial manufacturing and technology, to investigate how these processes could be incorporated into glass studio practice. Clear examples of this are the research projects of Angela Thwaites and Shelley Doolan. Both of these kiln formed glass artists chose to research how they could incorporate new technology into their practices. Thwaites explored how 3D printing could inform contemporary kiln formed glass and Doolan examined the role of technology within craft practice. Both adopted digital techniques and manufacturing tools in order to create works which, although firmly grounded within the process, asked questions about the limits and extensions these new innovations could offer to a kiln formed glass artist.

Both of these research projects begin to question the notion of craft in relation to the hand of the maker, the authenticity of the works produced and technologies' impact on the significance of the act of making. These innovations certainly lead us 'towards making the unmakeable', to quote the title of Thwaites's thesis. These are works which were digitally accurate and formally complex.

Artistic concerns that designing with a separation from the tacit understanding of a material, enforced by working solely on a digital platform, can create a lack of spontaneity and physical intuition within the final works are addressed. Here no such disconnect occurs as both Thwaites and Doolan are combining this new computer-based tool with their own empirical knowledge of the material, permitting them to work hand-in-hand with these computerised innovations to create technically accurate, multifaceted and unique works in glass.

My last researcher's interest has not been in pushing glass's formal possibilities or accurately controlling how to create intricate forms but in gaining a spontaneity and fluidity within the material. Sheila Labatt's research, entitled *Glass as Ink: Seeking Spontaneity from the Casting Process*, aims to emulate ink-like marks, as found in

Chinese brush painting and calligraphy, exploring the 'interface between control and chance where the artistic process ends and the unique properties of glass take over and are governed by heat, time and gravity.'

Here knowledge of technique and materiality are a necessity, unlike the examples previously mentioned and the elusive concept of spontaneity is examined. Although Labatt's project is not focused on the necessity for strict formal and image-based accuracy, it does have synergies with this project as it also references the transformation of a two-dimensional drawing/image/mark into a three-dimensional context or dimension.

As you can see from the examples discussed, the quality and diversity of research within kiln formed studio glass offers a rich context to which this thesis can contribute. Innovations are ongoing within glass working, as a relatively young artistic material is explored and exploited creatively.

Stefano Catalani, Director of Gage Academy of Art Seattle, noted in the 2015 study on the state of American Glass, carried out by the Glass Art Society and Chihuly Garden and Glass

It feels to me that in the last few years there's been an infusion of new perspectives, especially when it comes to technologies and the cross pollination between the glass world. . . and other technologies.

Dale Chihuly added.

.....we are in the age of transparency.

1.5. Research Methods

I undertook an extensive scholarly review of both lenticular lens production and lenticular print, focusing particularly on the technology and relationship between these two elements. Historical developments and references have informed an understanding of contemporary practices by breaking down these complex methodologies into basic forms. The observation of historical mechanisms and objects has taken place at the V&A Museum and Science Museum, London, the objective being to gain insight into the history of this field from its infancy as illusionistic optical devices and applications. Precedents within art which employ the miscomprehension of an image, confused perception or visual paradox were surveyed, notably through works within collections at the National Gallery, Tate Modern, Birmingham City Museum and the Imagine Museum, Florida.

The studio-based research worked through a series of phases, beginning with the evaluation of processes to place an image within glass through iterative and systematic testing. Here, digital ceramic transfer was identified as the appropriate technique for this research into the production of an illusionistic image. This was based on my tacit knowledge of the technique and its use in glass, in addition to an understanding of the precision needed to create a lenticular image.

Lens production also drew on empirical knowledge and methodical approaches to perfect casting. Collaboration with Tribal 3D Ltd, industrial holographic and lenticular printers proved invaluable in testing and problem-solving technical issues with both glass lens production and the calibration of an image. Digital working to create a successful lenticular image which meshed to the glass lens involved rigorous testing and the development of a methodology that spanned four different software packages, ensuring the project's cost-effectiveness and accessibility. Research here tapped into online resources, tutorials and assistance from US software developer Useful Byte (UB)¹³.

Dissemination of this research has so far taken place via the presentations of papers and talks at three different conferences, the most notable being the Glass Art Society Conference 2019, in Florida, United States. These provided opportunities for peer feedback, discussion and review, whilst exhibition of these final works at venues such as the British Glass Biennale 2017 and 2019 and the Royal College of Art Show 2019 have facilitated public response and feedback on the perception of the work. This feedback afforded a high degree of reflection and further analysis of the work, which has fed into amendments within draft versions and the final version of this thesis.

1.6. Overview of the Thesis

This PhD project has produced a body of glasswork and a written thesis. The structure of the written thesis is as follows.

[Chapter 2](#) discusses human visual perception, with particular focus on how we optically perceive and interpret three-dimensional space: this section explores the optical cues that inform our perception, and how these cognitive and physiological signals are decoded to make intellectual judgements about objects and positioning within a given environment. This includes a discourse on how these optical cues have been used by artists to capture the three-dimensional world. By analysing historical and contemporary references it discusses how we have been able to depict the

¹³ Useful Byte Software Ltd, <http://www.usefulbyte.com> .

natural world around us within the two-dimensional pictorial plane. This plotting of developments in mimetic illustrations, which adhere to Gestalt principles and the use of mathematical perspective, enables the association of a pictorial reference to the use of these optical cues.

Further examination, in [Chapter 2.5](#), considers more recent works of art that exploit this assimilated knowledge to create visual paradoxes. This, in addition to surveying the work of selected artists and their attempts to capture perceived depth, also highlights the agency that we as humans apply to recording our surroundings and the fascination that this illusionistic translation, from three dimensions to two, holds.

[Chapter 3](#) examines the optical properties of glass and how these have been used. Specific artworks are discussed in this section, exploring how artists working with glass have exploited these visual properties to create works that fascinate and confuse the observer. Here the visual characteristics of glass are discussed and applied to particular artworks.

[Chapter 4](#) provides further context by surveying the technological developments surrounding the image and the illusion of three dimensions. From early lens-based plotting devices that facilitated the translation of the world into a graphic reference, to scientific stereoscopic apparatus and early 3D technology, this chapter contextualises the image and our desire to capture realism through illusion. It charts the scientific endeavours that have led to today's convincing parallax-based 3D virtual realisations of real and imaginary worlds.

The [fifth chapter](#) discusses the practical aspect of this research, explaining the material processes and their use within the project. Set within the context of a studio glass practice, this section explains the decision making, analysis, reflection and practical techniques adopted. It methodically lays out the stages of systematic and iterative testing and evaluates each work as part of an ongoing empirical process.

[Chapter 6](#) analyses the practical outcomes of the project: the glassworks produced. Here the perceived illusion is discussed, in order to assess and reflect upon the issues and successes within this new body of work. As has been stated from the outset of this project, the imagery adopted within these works is not appraised for its conceptual integrity but simply its success in enabling the communication of enhanced depth, or three-dimensionality, when sited with the glass.

Finally, [the conclusion](#) gives an overview of the project's successes and suggests future applications and research synergies.

2. The Visual Perception of Objects and Space

My first area of exploration was to investigate how we visually perceive images and interpret three-dimensional space. It should be noted that this is a basic overview of the biological and psychological processes, the inclusion of which I feel is necessary in order to give a full understanding of the research subject matter.

In order to comprehend the world, the brain rationalises the information collected from our senses. It is important to note that only part of this perception comes directly from the eyes: this information, in conjunction with an intellectual response, forms our interpretation of what we see. The processes of receiving and analysing visual information allows us to perceive.

2.1. The Human Eye

Initially, our eyes gather visual data. (See Figure 9)

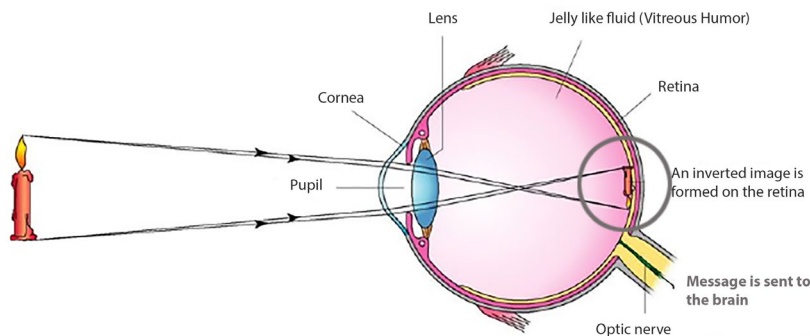

Figure 9.
Diagram of the Eye

This data is in the form of light. Humans have the ability to recognise red, green and blue light waves. The iris controls the amount of light data that the eye takes in by contracting and relaxing to increase or decrease the size of the pupil. This light passes through the cornea, a protective sheet, and then into the lens. Using muscles attached to the lens, it is able to adjust and bend the light, focusing it on the retina at the back of the eye. Here millions of light sensitive receptors, called rods and cones, change shape when in contact with the light, triggering an electrical message via the optic nerve to the brain. The area at the back of the eye has between six and seven million cone cells. These cells contain one of three colour-sensitive proteins, which can react to either red, green or blue light waves. Over half of our cones respond to red light, one third to green and just two per cent to blue, situating our vision within a yellow-green spectrum. A further 120 million rod cells are also located on the

retina. These detect light, but not colour. Although we only detect three different light waves, these combine to allow the brain to perceive millions of shades.¹⁴

What we see via a retinal projection from the eyes is crucially then translated and rationalised into something different. The eye enables the creation of an image on the retina: this message is carried to the brain and certain physical and chemical effects vibrate the muscles and nerve endings. As we develop from childhood, these basic directions become subordinate to more sophisticated cognitive processes within higher levels of the cerebral cortex. What we perceive that we see is a combination of complex visual judgements that are then combined with erudite intellectual decisions. Thus our basic sense of sight starts this chain of analysis by providing the raw data, but it is then the learnt judgements that form our perception of the world around us.

2.2. Perceived Vision

This rudimentary summary of perception is presented in order to create a basic and fundamental understanding of the principal considerations addressed in this research.

As explained in [Section 2](#), the eyes take in data, which our brain interprets. Although gathered by both eyes simultaneously, the images/schemata can be organised into monocular¹⁵ and binocular cues.¹⁶ Monocular visual cues allow us to perceive depth using just one eye, whilst binocular ones require both eyes to gather information simultaneously. Crucially, visual stimuli are not the only references that the brain uses in order to form a perceived understanding of our environment. Ongoing research within neuroscience, psychology and biology continues to link the use of our other senses to the refined judgements which take place as we rationalise the world around us. This essential combination of cognitive processes and visual information is something that has long been acknowledged.

¹⁴ Jodie Tyley, *The Science of vision: How do our eyes see?* September 2015, <https://www.independent.co.uk/life-style/health-and-families/features/the-science-of-vision-how-do-our-eyes-see-10513902.html> (Accessed 15/01/16)

¹⁵ These are clues that can be used for depth perception that involves using only one eye. Kendra Cherry, 'Monocular Cues for Depth Perception', *Verywellmind* (Nov 2019) [Accessed 1/12/19] <https://www.verywellmind.com/what-are-monocular-cues-2795829>

¹⁶ Binocular cues are visual information taken in by two eyes that enable us a sense of depth perception, or stereopsis.

Sarah Phoenix, 'Binocular Cues: Definitions and Example', *Study.com*, <https://study.com/academy/lesson/binocular-cues-definition-examples.html>. [Accessed 12/10/19]

Exploring the Optical Perception of Image Within Glass

Immanuel Kant (1724-1804) proposed that the mind could be divided into two elements, one of sensibility, which processes the basic data feed, and an active element regarding the intellectual understanding of that data.¹⁷

‘intellect’ - the faculty of reasoning and understanding objectively, especially with regard to abstract matters.¹⁸

As Rudolf Arnheim (1904-2007) describes in his book *Visual Thinking* (1969), ‘intellect’ in this instance relates to a series of mental operations which occur to manufacture the perception of an image. These involve receiving, storing and identifying the visual information and therefore are significantly linked to memory, thinking and learning.¹⁹

In reference to art, Arnheim states:

If one wishes to be admitted to the presence of a work of art, one must, first of all, face it as a whole. What is it that comes across? What is the mood of the colours, the dynamics of the shapes? Before we identify any one element, the total composition makes a statement that we must not lose. We look for a theme, a key to which everything relates. If there is a subject matter, we learn as much about it as we can, for nothing an artist puts in his work can be neglected by the viewer with impunity. Safely guided by the structure of the whole, we then try to recognize the principal features and explore their dominion over dependent details. Gradually, the entire wealth of the work reveals itself and falls into place, and as we perceive it correctly it begins to engage all the powers of the mind with its message.²⁰

John Locke (1632-1704) also suggested that our knowledge of reality is constructed through experience derived from our senses.

¹⁷ Andrew Stephenson, *Kant's Theory of Experience*, Merton College University of Oxford.p.11-12. https://ora.ox.ac.uk/objects/uuid:12e951eb-8eef-4112-b90d-52e7d4fe6251/download_file?file_format=pdf&safe_filename=THESIS01&type_of_work=Thesis Accessed 21/12.18]

¹⁸ ‘Intellect’, *Lexico*. <https://www.lexico.com/en/definition/intellect>

¹⁹ Rudolf Arnheim, *Art and Visual Perception: A Psychology of the Creative Eye*, University of California Press, Revised addition 1974, p.8.

²⁰ *Ibid*, p. 8.

In the second edition of his essay *Concerning Human Understanding* (1694), he discusses a question posed to him by his close friend the philosopher William Molyneux (1656-1698).

Suppose a Man born blind, and now adult, and taught by his touch to distinguish between a Cube, and a Sphere of the same metal, and nighly of the same bigness, so as to tell, when he felt one and t'other; which is the Cube, which the Sphere. Suppose then the Cube and Sphere be placed on a Table, and the Blind Man to be made to see: query. Whether by his sight, before he touch'd them, he could now distinguish, and tell, which is the Globe, which the Cube? I answer, not. For, though he has obtained the experience of how a globe, how a cube affects his touch, yet he has not yet obtained the experience, that what affects his touch so or so, must affect his sight so or so; or that a protuberant angle in the cube, that pressed his hand unequally, shall appear to his eye as it does in the cube.²¹

This link between the conscious mind and reality is illustrated in the work of early twentieth-century French surgeon, Moreau. In 1913 Moreau removed cataracts from an eight-year-old boy, with the anticipation that he would regain his vision. Moreau then documented how the patient was unable to recognise anything by sight, though his optical system was fully functioning. It took many months of training before the boy could recognise a small number of simple objects. As Semir Zeki notes, Moreau stated:

It would be an error to suppose that a patient whose sight has been restored to him by surgical intervention can thereafter see the external world. The eyes have certainly obtained the power to see, but the employment of this power still has to be acquired from the very beginning. The operation itself is of no more value than that of preparing the eye to see; education is the most important factor. The [visual cortex] can only register and preserve the visual impressions after a process of learning [...] To give back his sight to a congenitally blind patient is more the work of an educationalist than that of a surgeon.²²

²¹ John Locke, *An Essay concerning Human Understanding* are from the P. H. Nidditch edition (Oxford: Clarendon Press, 1975). II.ix.vii, p. 146.

²² Semir Zeki, *Inner Vision: An Exploration of Art and the Brain* Oxford: Oxford University Press, 2000, p.224 .

2.3. Monocular Optical Cues and Their Interpretation in Art

As stated in the previous section, the raw data delivered to the brain via the eyes is not sufficient for us to construct an understanding of the world around us. Evidently it is necessary to draw on our cognitive processes and sensibilities in order for the brain to build a reasonable assumption of what we are looking at.

This section discusses the various learnt monocular visual cues we take on board in order to construct a perception of objects and space and examines artworks which adopt these assumed realities in order to convey or confuse the illusion of spatial stability.

It is important to note at this stage that within the context of this research I will be focusing predominantly on Western philosophies and developments within art that attempt to communicate three-dimensional depth within the two-dimensional pictorial plane. This is not to say that these were the only approaches taken and developments made, but in order to present a concise reference I felt it necessary to focus specifically on the depictions of three-dimensional space within Western art.²³

Light and Shadow

From birth, a baby can distinguish movement and light, and can make out large shapes and facial forms. This is then thought to develop, at between three to four months, into the ability to detect and distinguish colours.²⁴ It is from birth that an infant begins to gather information that will inform their ability to perceive their surroundings throughout life. The cognitive rationalisation of this data allows the brain to begin to make assumptions and build formulas for interpreting this information. This is the beginning of our visual cerebral default condition, constructed formulae that allow us to build a feasible spatial understanding of our world. A key example of this is the assumption we make about light and shadow. In our world, the sun, our main source of light, is always above us, casting light down onto objects. This conditioning leads the brain to assume by default that light usually comes from above, and it employs this default to interpret shapes. The image below (Figure 10) demonstrates this learnt form of visual interpretation.

²³ The term 'Western art' largely describes the art of Western Europe but is also used as a general category for forms of art that are now geographically widespread but that have their roots in Europe. 'Western Art', Discover Art, Art Gallery of New South Wales, <https://www.artgallery.nsw.gov.au/discover-art/learn-more/western-art/> [Accessed 10/03/19]

²⁴ Jessica Timmons, When do newborn babies start to see? *Healthline* (August 2016), <https://www.healthline.com/health/parenting/when-do-newborns-start-to-see#Your-babys-sight:-newborn-to-4-months> [Accessed 21/09/18]

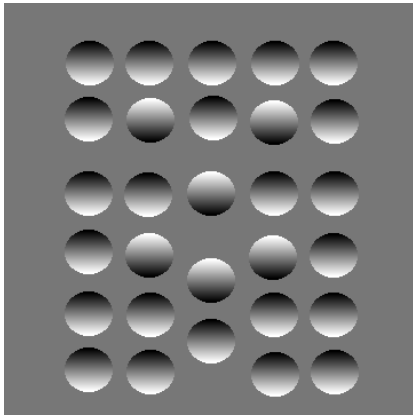

Figure 10.
Depth from Shading
(with Organisation Using Gestalt Principles) [Monocular Cue],
<http://www.skidmore.edu/~hfoley/PerCLabs/Distance.htm>

Here we read the image as showing mainly concave circular forms, with light highlighting the base of the dish-like forms. There are also six convex disc shapes: these have light hitting the top edge. It is the brain's assumption that light comes from above, which dictates our recognition and perception of these forms. As a result, concave or convex forms can be read in reverse, depending upon how we perceive the light source. Within these principles and conventions the brain assumes that objects that are brighter are closer to the viewer than darker ones.

In art, one can see these instinctual cerebral assumptions being manipulated, in particular, in the work of Maurits Cornelis Escher (1898-1972), for example in his lithograph *Convex and Concave* (Figure 11)



Figure 11.
M. C. Escher *Convex and Concave* (1955)
Lithograph. 33.5 x 27.5cm
© 2017 The M. C. Escher Company

The illusion created in this lithographic rendering manipulates our assumptions about light. Here, Escher creates a situation in which our understanding of perception and form is challenged by the tonal palette or shadows applied to these forms. This is known as a dichotomous perceptual decision in the brain, as essentially the brain can interpret what it is seeing in two different ways. Here the viewer's vision intermittently shifts from one interpretation of the image to the other.

Atmospheric Perspective and Textural Gradient

As mentioned, light direction is only one of the learnt modes that our brain defaults to when trying to decipher what we are seeing. Atmospheric perspective also forms a cognitive default.

The observed atmospheric changes, referenced within this visual cue in relation to distance, are a result of the scattering of light by tiny particles in the air; these dust and vapour particles cause the light to bend, creating a haze which softens colours and narrows tonal contrast. It can also cause a blue or purple hue to appear in the distance, as short-wavelength blue light is scattered furthest by these particles.²⁵ For example, distant mountains can be perceived to have a blue hue and hazy appearance, whilst closer elements have a greater range of contrast. The images below, which have been edited digitally in Photoshop, demonstrate this phenomenon. (Figure.12)

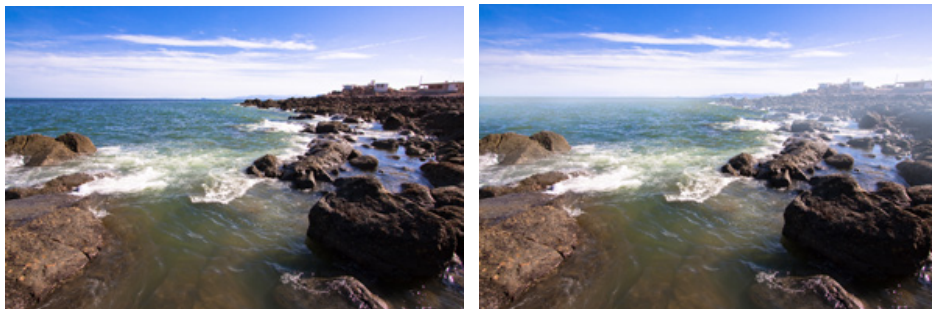

Figure 12.
Stan Prokopenko Example Images, The Illusion of depth, Contrast, Aerial Perspective and Form (April 2013).
By kind permission of the artist

The foreground and background of the image on the left are equally sharp and have a high range of contrast. Now consider the edited image on the right. The background has become less sharply in focus and gradually hazy, and the tonal contrast has been narrowed to a palette of pastel mid-tones. The scene now

²⁵ Stan Prokopenko, (2013), *The Illusion of depth, Contrast, Aerial Perspective and Form*, (April 2013) online https://www.proko.com/illusion-of-depth-contrast-aerial-perspective-form/#.XePFmC2cb_Q. [Accessed 20/04/17]

gradually transitions from a sharply focused foreground with a wide tonal range to a hazy background with minimal contrast, and in doing so generates a stronger sense of spatial depth and distance within the composition.

When applying these principles and an understanding of aerial or atmospheric perspective, this visual cue can be used to create the illusion of depth or recession within the pictorial image.

Leonardo da Vinci (1452-1519) was the first to use the term 'aerial perspective' in his treatise on painting. In this he stated:

If in your picture you want to have one appear more distant than another, you must first suppose that air is somewhat thick, because, as we have said before, in such a kind of air the objects seen at a great distance, as mountains are, appear blueish like the air, by means of the great quality of air that interposes between the eye and such mountains.²⁶

Texture gradient is also a recognised learnt cue that we use in order to calculate spatial depth and distance. Just as we have learnt through observation that the atmospheric effect of light on dust and vapour particles has a direct visual reference to distance, the brain has also formed assumptions about texture and gradient. Here we accept that the nearer we are to an object the more detail and texture we are able to see. So smoother forms can be perceived as further away and objects with more textural detail as closer.

This painting by Caspar David Friedrich (1774-1840), entitled *The Watzmann* (Figure 13), illustrates this notion of atmospheric interference with regard to the colours and tonal intensity used to communicate distance within a composition.

²⁶ Leonardo Da Vinci, A treatise on painting [ca. 1540], trans. by John Francis Rigaud, 1742-1810; (London, J.B Nichols and son, Published 1835). p.180.



Figure 13.
Caspar David Friedrich *The Watzmann* (1824–25)
Oil on canvas. 135 x 170 cm National Gallery Berlin, Germany. © bpk /
Nationalgalerie

Here we get a real sense of the distance from the foreground to the top of the snow-covered mountains in the background. Friedrich has also employed texture gradient rules within this composition to make the depth of the composition more convincing.

As mentioned, the optical cue of texture gradient, in order to convey depth within a two-dimensional depiction, relies on the fact that we focus on the object/s close to us. In a single-viewpoint composition, the objects that are not the main focus are less detailed, rendered almost as peripheral vision. Thus in this work the foreground of rocks and heathland is detailed, and crisply in focus. However, as the suggested distance from the viewer increases the detail is decreased, so that the mountains in the distance are more simplistic, a more suggestive rendering than a detailed one.



Figure 14.
M. C. Escher *Waterfall* (1961)
Lithograph. 30 x 38cm
© 2017 The M.C. Escher Company

In terms of art that explores and exploits the optical cues, some of the best-known modern examples are those by M.C. Escher. (Figure14).

Here in *Waterfall*, Escher is manipulating our assumption of what we are seeing by using a range of cues. He utilises aerial perspective to add depth of field and tonal contrast, challenging our understanding of the foreground and background, and of how light falls.

Escher has used aerial perspective cues by adopting a lighter tone for the surrounding terraces to add depth, but this is not the primary illusion. The tonal contrast used to depict the building and waterways also seems a convincing construct. This technique offers the viewer a familiar scene and ensures that they focus on the main element, the central watermill. It is only when trying to follow the flow of the water that the instability of this constructed scene is revealed.

In the nineteenth century, British painter J.M.W. Turner (1775-1851) pushed aerial perspective rules to their limit, creating great drama and atmosphere. This work, entitled *Distant View of Coblenz and Ehrenbreitstein* (Figure 15), created during his second Meuse-Moselle Tour of 1839, uses aerial perspective's gradation of colour and tone to emphasise spatial depth. It captures a sense of the time of day and the atmospheric conditions present during the making of the work.



Figure 15.
Joseph Mallord William Turner *Distant View of Coblenz and Ehrenbreitstein*
(c. 1839)
Gouache and watercolour on blue wove. 13.9 x 19cm
© Tate 2020

Within this semi-abstract work there is no reference to texture gradient, as the detail has given way to the atmospheric gestural reference to the landscape. This work is about capturing the depth and emotional atmosphere within the scene.

Finally, in this section on aerial perspective, I wish to look at the work of contemporary artist Mariele Neudecker. Neudecker has created three-dimensional works which capture a reference to emotion and atmosphere, like Turner, by using the notion of aerial perspective.



Figure 16.
Mariele Neudecker *I Don't Know How I Resisted the Urge to Run* (1998)
Mixed media including water, acrylic medium, salt, fibreglass. 75 x 90 x 61cm
By kind permission of the artist

This piece, entitled *I Don't Know How I Resisted the Urge to Run* (Figure 16), created in 1998, consists of a glass vitrine filled with water, acrylic medium, fibreglass models and other components to frame our view of a misty forest. As part of the illusion, we are made to feel that the forest is deeper or larger than the tank within which it is encapsulated. The heavy density of the liquid within the vitrine creates a visual aerial perspective effect, in conjunction with the dramatic lighting, as trees fade into the distance and light bleeds through the fog. The atmosphere is an eerie one, but is this because we are led by the title, referencing the creator's need to escape from a virtual bogeyman?

Neudecker's vitrine works, unsurprisingly, are often inspired by the Romantic paintings of [Caspar David Friedrich](#), discussed above. Like Friedrich's paintings these three-dimensional worlds have a dramatic, Gothic feel and great sense of spatial distance.

Adrian Searle mentions this in his review of Neudecker's 2000 exhibition at the Ikon Gallery in Birmingham.

She re-creates misty forests, mountainscapes, tumbles of rock and scree, peaks and valleys in miniature. All that's missing is the pondering subject, the figure in the painting to witness the scene and give it its sense of scale, immeasurable distance and magnitude. We wonder, too, at the artifice with which Neudecker creates an illusory geography as much as we do at the meaning of them.²⁷

Visual Interposition or Overlapping Cues

Intuitively, through our observed cumulative knowledge, we perceive things with a complete outline as being in front of objects with a broken outline. (See Figure 17)

²⁷ Adrian Searle. (2000), *The Guardian*, Art & Design: If you go down to the woods today, (2000).<https://www.theguardian.com/culture/2000/oct/03/artsfeatures> , [Accessed 13/04/17]

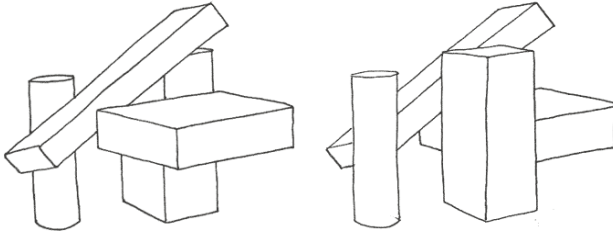

Figure 17.
Overlapping Principle Diagram

Again, this is something that we identify in reality and apply as a default when rationalising or attempting to depict two-dimensionally what is in front of us. As a species, we have always striven to capture a likeness of our natural world, and this is documented very early in art history by the prehistoric paintings at sites such as the Chauvet Cave, France (c. 30,000 BC) (Figure 18). Although theorists do not agree on why these paintings were made - whether for religious ceremonies, hunting rituals or simply as creative expression - what they do agree on is that in these paintings and engravings the artist has clearly and reasonably accurately depicted elements in the natural world around them.

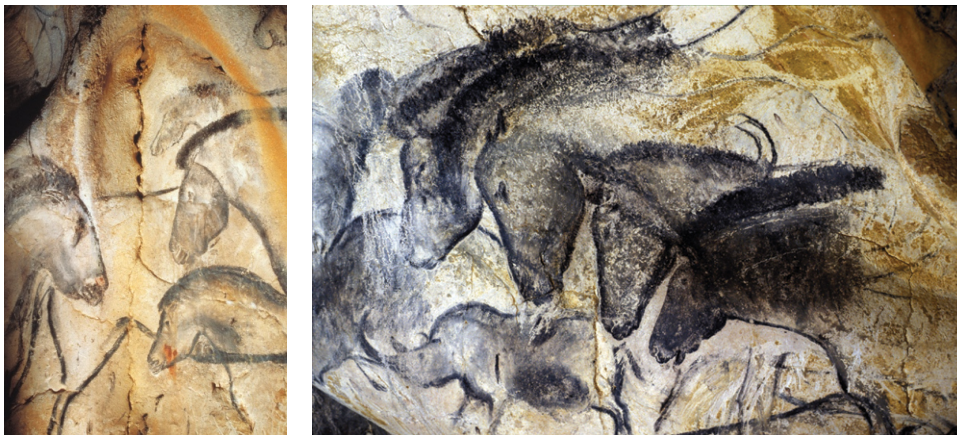

Figure 18.
Chauvet Cave (c. 30,000 B.C.)

These early depictions address monocular cues. Here we see an understanding of proportion, brought about through cognitive study of these animals, but also the use of interposition or overlap to create the illusion that one horse is in front of the other in the herd, creating a shallow depth within the composition. It is also clear from the images above that elements of the animals depicted are not complete. Whether this is due to patches of the illustrations being worn away over time or the quick sketchy nature of the marks made intentionally by the artist is impossible to say but it is obvious that subconsciously we, as viewers, are able to 'fill in the gaps' to make the animal complete.

Of course, within contemporary art the interposition of figures or objects within a scene is commonplace and enables us to view the image as a reality, a believable composition.



Figure 19.
Sandro Botticelli *Madonna of the Magnificat* (1481)
Tempera on panel. Diameter 118cm
By kind permission of the Uffizi Gallery, Italy

The early Renaissance painting *Madonna of the Magnificat* by Botticelli (Figure 19) uses interposition to create depth within this group scene. Proportionally we read each figure as being correct in relation to their assumed age; again, optically we can use the fact that we recognise these objects as figures to give a relative scale to each element, allowing the landscape behind to be read as distant. Shadows also play a major role, not only in giving each figure a three-dimensionality but predominantly in convincing the viewer of the positioning of each figure and their spatial relationship.

Relative Scale

Relative scale, seen in the example above, is another visual cue that we have learnt to apply when assessing our surroundings. This occurs when we recognise an object and are already aware of its size, such as a house, car, figure etc. With this learnt data our brain is able to compare the size of the recognised object in comparison with its surroundings and roughly calculate the space between the viewer and the object.

For example, in the painting below (Figure 20), *Paris Street: A Rainy Day* (1877) by Gustave Caillebotte (1848-1894), we recognise figures in the street which recede in scale depending on how far back within the composition they are placed. We are also familiar with the paving stones that, in addition to working in perspective, also decrease in size from foreground to background. The carriage to the left of the composition, which is only partially in view, also gives the viewer a sense of scale. Caillebotte has used familiar forms to create a convincing view of this street scene. Aerial perspective has also been used to add to the perception of depth. The distant buildings show less tonal contrast: a softening of the colour of the brick, in addition

Exploring the Optical Perception of Image Within Glass

to a looser application of the paint, makes the distant figures and buildings mere suggestions, rather than detailed renderings of these familiar forms.

Caillebotte's recognisable scene has been composed to create a very convincing visual account of a Parisian boulevard; the Surrealist painter René Magritte (1898-1967), on the other hand, used the visual cue of relative size to produce perceptual confusion in his work.



Figure 20.
Gustave Caillebotte *Paris Street: A Rainy Day* (1877)
Art Institute of Chicago. Oil on canvas. 212.2 x 276.2cm
By kind permission of the Art Institute, Chicago



Figure 21.
René Magritte *Personal Values* (1952)
Oil on canvas. 80.01 x 100.01cm
San Francisco Museum of Modern Art, purchase through a
gift of Phyllis C. Wattis Charly Herscovici, Brussels / Artists Rights
Society (ARS), New York photograph: Katherine Du Tiel

Magritte's 1928 work *Personal Values* (Figure 21) presents the viewer with what appears to be a room crammed with familiar objects, but the proportion of these objects is almost figuratively human. This creates a sense of incongruity and disorientation. Then we notice that the room is inverted, with the sky internal to the walls. We are left wondering why these normally innocuous objects, with their change of scale, appear threatening and unnerving. The observer is left to question what the artist is trying to say.

As Magritte is said to have stated:

My painting is visible images which conceal nothing; they evoke mystery and, indeed, when ones sees one of my pictures, one asks oneself this simple question, 'What does that mean?' It does not mean anything, because mystery means nothing, it is unknowable.²⁸

Magritte created a paradoxical world that is intriguing and unnerving, a visual contradiction of normality and one that confuses the viewer, as recognisable forms are taken out of context, jarring our assumed perception of the world.

Linear or Convergent Perspective

The final example of a learnt or cognitive cue that the brain uses to decipher visual data is linear or convergent perspective. This relates to horizons and vanishing points that we experience in day-to-day environments. These cues allow us to use our cognitive knowledge to perceive distance. These visual assumptions are clearly demonstrated in the so-called 'Ponzo' illusion²⁹ (See Figure 22). Because the brain assumes that the two yellow lines within this diagram sit on tracks in linear perspective, it perceives the yellow line at the top of the track to be longer than the one at the bottom. Of course, both lines are exactly the same size; but because this vanishing point perspective is familiar to us, we assume that foreshortening will occur. Here the top line is perceived to be in the distance, and if this is the case, if it is the same size as the lower line it would get shorter as it moved further away; therefore it must be longer within this context.

²⁸ Magritte Foundation, <https://www.renemagritte.org> [Accessed 20/09/19]

²⁹ The Ponzo Illusion was discovered by Mario Ponzo (1882 - 1960), an Italian psychologist. The Ponzo Illusion is one among a number of illusions where a central aspect of a simple line image—e.g. the length, straightness, or parallelism of lines—appears distorted by other aspects of the image—e.g. other background/foreground lines, or other intersecting shapes. ('The Ponzo Illusion', *illusions index*, <https://www.illusionsindex.org/i/ponzo-illusion> [Accessed 25/01/20])

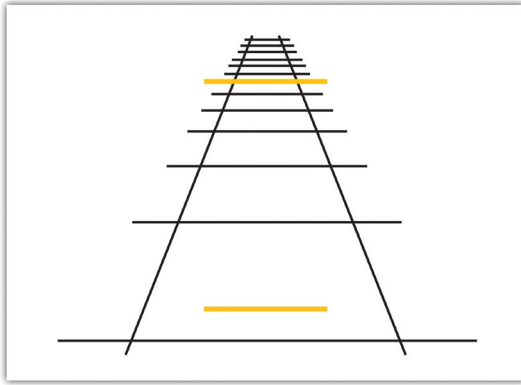

Figure 22.
Mario Ponzo A version of the Ponzo Illusion (originated in 1911)

This reliance on our cognitive understanding of perspective is also demonstrated in the Ames Room illusion (Figure 23), that creates a Magritte-like take on scale.



Figure 23.
Vintage Ames Room Illusion
<http://www.anopticalillusion.com/page/74/>,
posted 3rd July 2012.

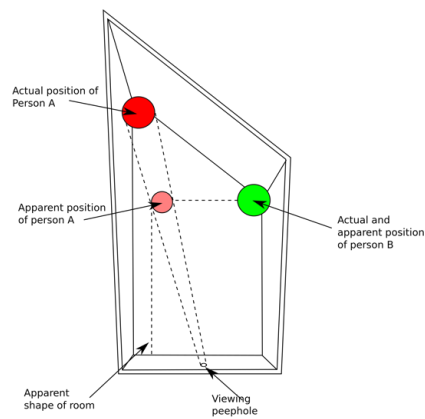

Figure 24.
Diagram of the True and Apparent Position of a Person in an Ames Room and the Shape of That Room
https://en.wikipedia.org/wiki/Ames_room

In this 'forced perspective'³⁰ illusion, devised by Adelbert Ames Jr (1880-1955) in 1946, the right corner of this specially designed room is nearer to the viewer than the left. This creates the illusion that the man standing on the right-hand side is much larger than the man on the left. The diagram (Figure24) illustrates the true shape of the room and positioning of the figures in order to construct this sophisticated visual illusion.

Within contemporary art the use of perspective is commonplace. In drawing or painting, this is referred to as linear perspective. In linear perspective, all lines that

³⁰ The use of objects or images that are larger or smaller than they should be to suggest that they are nearer or further away than they really are. ('Forced perspective', *Collins Dictionary*, <https://www.collinsdictionary.com/dictionary/english/forced-perspective> [Accessed 12/10/19])

are parallel converge as they run along to a point at a person's eye level (known as the horizon line) in the picture. This phenomenon is known as 'convergence'.

Josef Albers exploits the optical cues of convergence perspective and interposition in his work *Structural Constellation*, (ca.1950) (Figure 25). The optical illusion within this piece plays with our perception of space by using simple lines which exploit our visually learnt understanding of perspective and overlap to create confusion which disorientates the viewer's understanding of what is in the foreground and what sits behind. Although these simple lines are stylistically rendered, the viewer interprets an unstable dimension.

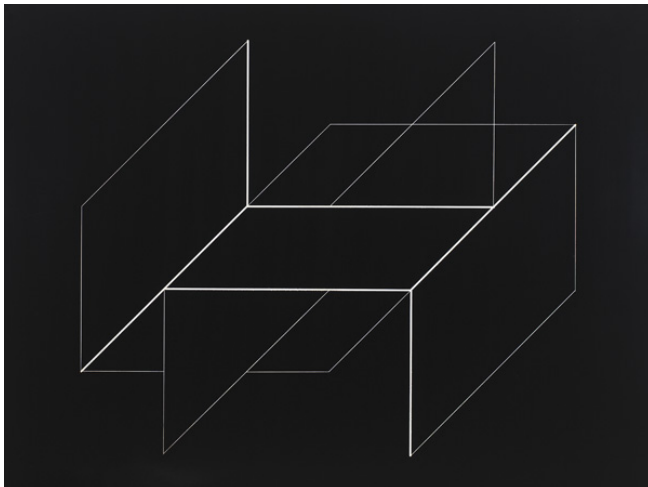

Figure 25.
Josef Albers *Structural Constellation* (c. 1950)
Machine engraving on black laminated plastic. 43.2 x 57.2cm
2020 The Josef and Anni Albers Foundation/ARSNY/DACS

The foundation of these principles of perspective can be found within the history of art. From the 5th century BC there is evidence of depth representation in art in both geometric and more figurative forms. Ancient Greek philosopher Plato and his contemporaries in their writing mention the dramatic use of perspective related effects in the scenery for plays by Aeschylus and Sophocles. Agatharchus, commonly acknowledged as the first theatrical scene-painter, is credited with a written commentary on 'his use of convergent perspective', and it is this work that is said to have inspired several Greek geometers of the period to analyse the 'projective transformation' mathematically.³¹

Geometric perspective occurs when all straight lines in space project to points in the picture plane. It is at its most extreme when head-on in the composition: when a projection line will contract to a point in the picture plane. So, when using

³¹ Jeremy Killian, *That Deceptive Line: Plato, Linear Perspective, Visual Perception and Tragedy*. *The Journal of Aesthetic Education*, 46 (2), 89-99, May 2012. p.89 Line 5-12

perspective to depict space it is crucial to identify all parallel elements within the scene and ensure that their projections are drawn to a common vanishing point.

Sadly, no examples of this type of perspective has survived from Ancient Greek painting, but Roman works from the 1st century AD found in the ruins of Pompeii depict a dynamic three-dimensional portico as a stage backdrop to a production of *The Myth of Orestes*.³² (Figure 26.)

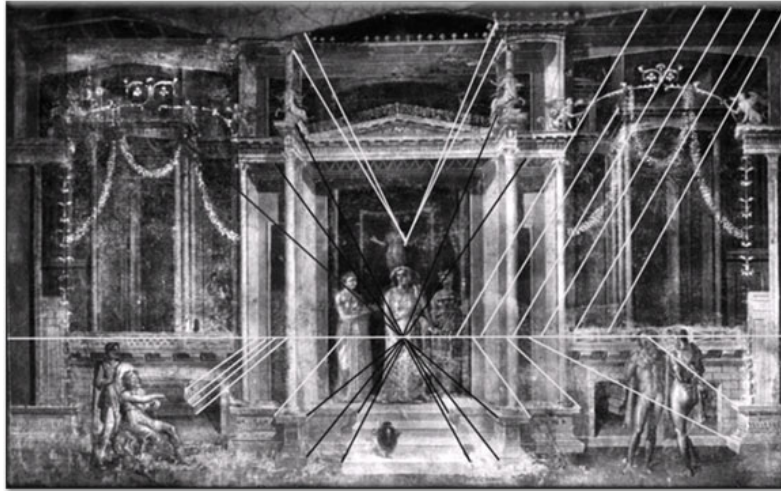

Figure 26.
Pompeian Mural of the Pageant of Orestes, 2nd century A.D.
2020 Christopher W. Tyler

In this image the backdrop shows evidence of the use of light and shadow to create form, surface and depth, in conjunction with interposition and linear perspective. That said, it can clearly be seen, via the addition of white lines that track angles within the composition (the orthogonals) that this configuration does not work using contemporary principles of perspective, as the lines do not all converge to a single central vanishing point.

This part-calculated, part-intuitive rendering does give some suggestion of appropriate perspective but indicates a deficiency of understanding with regard to the core geometric principles. In this period this seemingly intuitive grasp of the convergence concept in perspective did enable Roman painters to create a high degree of perceived three-dimensionality in murals and scenery, but at this stage did not create a totally accurate visual construction.

³² Christopher Tyler. Perspective as a geometric tool that launched the Renaissance, June 2000, Proceedings of SPIE – The International Society for Optical Engineering.
https://www.researchgate.net/publication/252564519_Perspective_as_a_geometric_tool_that_launched_the_Renaissance [Accessed 12/01/19]

These early examples of the use of perspective in Western art were developed further during the Renaissance. European artists from Giotto (c.1267–1337) onwards, were clearly working toward this goal of rendering a likeness of the world around them in paint. Building on this knowledge, the first known painting to use linear perspective, as we know it today, was by Filippo Brunelleschi, a Florentine architect (1377-1446). Credited with the discovery of linear perspective, his depiction of the Florence Baptistery was said to use a linear system of perspective to project the illusion of depth onto the pictorial two-dimensional plane by using a horizon line and vanishing points.³³ Sadly this pictorial evidence of the use of linear perspective is now lost, but written descriptions of the public perspective experiments that Brunelleschi carried out c.1425 are given in Brunelleschi's biography, *Vita di Brunelleschi*, thought to have been written in the 1840s by mathematician and scholar Antonio di Tuccio Manetti.³⁴ (See Figure 27).

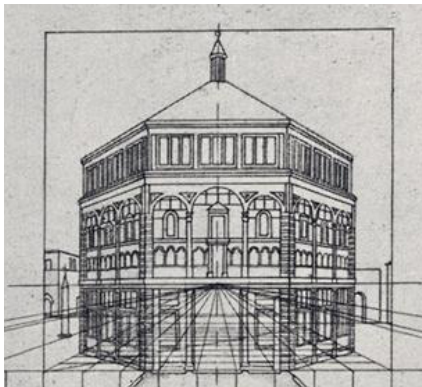

Figure 27.
Diagram Demonstrating Filippo Brunelleschi's Perspective Technique from a Lost Painting of the Battistero di San Giovanni.
Kunsthistorisches Institut in Florenz Max-Planck-Institut. © 2006, Scala, Florence / Art Resource,

Later in the 15th century this departure from stylisation towards the mathematical plotting of space upon a two-dimensional plane can clearly be seen in Piero della Francesca's *The Flagellation of Christ* c.1460. (Figure 28)

³³ Blumberg, N. Encyclopaedia Britannica Online (2016). "Linear perspective", [online]. Available at : www.britannica.com/art/linear-perspective. [Accessed 22/04/16].

³⁴ Anonio Di Tuccio quoted in Samuel Y, Edgerton, Jr, *Brunelleschi's First Perspective*, Art Lombarda, Vol. 18, No. 38/39, IL FILARETE (Italy: Published by: Vita e Pensiero – Pubblicazioni dell'Università Cattolica del Sacro Cuore, 1973). <https://www.jstor.org/stable/43133328>. [Accessed 10/12/19]. p172.



Figure 28.
Piero della Francesca *The Flagellation of Christ* (late 1450s)
Oil Paint and tempera on panel. 58.4 x 81.5cm © Galleria Nazionale delle Marche, Italy

This small panel, measuring only 58.4 x 81.5cm, has long intrigued scholars and academics due to its spatial accuracy and mathematical precision. This painting is believed to be so accurate that scholars have been able to deduce, from its proportion and detail, the size of the spaces being depicted, the height of walls and the scale of the figures after foreshortening, in the composition. This work has been analysed in detail and acclaimed for its mathematical correctness with regard to contemporary rules on perspective.³⁵

A particular emphasis has been placed on accuracy in the extreme foreshortening illustrated by the decorative floor tile arrangement. In addition to using contemporary perspectival cues, this small image also uses aerial perspective, as the scene recedes backwards, using interposition and texture gradient to add a further level of sophistication to a convincing scene.

The construction of the painting has also been analysed, and it is felt by many that this too has been mathematically laid out to add significance to the characters portrayed: 'No picture could exude a more pronounced air of geometric control and no painting was ever more sumptuously planned.'³⁶

Piero della Francesca's treatise *De Perspectiva Pingendi*, (On Perspective for Painting), written between 1472 and 1475, clearly cites the arithmetical progression for the diminishing size of columns and the figures within a two-dimensional

³⁵ Wittkower, R & Carter, A.R. *The Perspective of Piero della Francesca's Flagellation*, *Journal of the Warburg and Courtauld Institutes*, 16. 3/4 (1953), 292–302

³⁶ Martin Kemp, *The Science of Art: Optical Themes in Western Art from Brunelleschi to Seurat* (New Haven, CT: Yale University Press, 1992), p.30

rendering. It is thought to have been written possibly thirty-nine years after Alberti's first written account of the theory of linear perspective.³⁷ Piero's treatise is considered to contain the basis of the new Renaissance geometric perspective. Theorists agree that his work extends Alberti's theories in a more explicit way, so enhancing the knowledge of how to create illusionistic and geometric spatial rendering within painting.

Patrick Hughes is a contemporary artist whose work captivates viewers: in this case, he manipulates our visual understanding of perspective and creates dichotomous perceptual paradoxes within the brain.



Figure 29.
Patrick Hughes *Superdupersperspective* (2002)
Birmingham Museum and Art Gallery
By kind permission of the artist

In Hughes' 'reverse perspective' painting *Superdupersperspective* (Figure 29), we are initially seduced into recognising what we are seeing. The perspective appears correct, and the optical cues relating to light, aerial perspective and textural gradient or detail all appear to be faithful to our understanding of the scene. But it is only when the viewer starts to move around in front of the work that a sense of uncertainty and instability is provoked. Hughes' work adopts what the artist calls 'reverse perspective' - the areas in the composition that appear to be at the front, or closest to the viewer, are in fact at the back; it is only the clever use of perspectival lines and high detail on these virtual foreground images that leads us to believe that they are closer to us. So once we start to move, ideally in an arc around the piece, we start to get a greater exaggeration of the composition's perspective and then the perceived image starts to bend in on itself, eventually leading to a moment of paradox before the shape of the canvas reveals how the illusion is created and the viewer can rationalise just what they are seeing.

³⁷ Ibid.

Finally, in this section on the use and exploitation of perspective cues, I discuss the work of James Turrell. On a different level, Turrell, too, is playing with the science of how we perceive the world. Having studied Perceptual Psychology at Pomona College in 1965, Turrell completed a master's degree in Art in 1973. Turrell carefully explores and manipulates how our optical systems work, to remind us at a fundamental level that what we see is an illusion.



Figure 30.
James Turrell *Afrum I (White)* (1966)
Cross corner projection.
© Guggenheim Museum, New York Panza Collection

He too exploits the paradoxes of visual perception, and this phenomenon is explored through his work *Afrum I (White)* (Figure 30). Here a very bright light in the corner of a dark space gives the appearance of a floating white cube hovering in front of the back wall. Within this paradox the viewer's brain shifts between seeing this work as a solid white cube, as described, and a flat beam of light, as your brain can technically see this image/object either way.

2.4. Gestalt Theory

During the 1920s the Gestalt theorists were the first group of psychologists to analyse how we perceptually organise and rationalise the optical raw data provided via the eyes. This rationalisation holds no apparent basis within learnt visual cues but indicates intuitive tendencies in terms of how visual information is systemised. The theory was rooted in the thinking of Johann Wolfgang von Goethe (1749-1832), Ernst Mach (1838-1916), and Christian von Ehrenfels (1859-1932), and it was this

work, that informed the research by Max Wertheimer, Wolfgang Köhler, Kurt Koffka and Kurt Lewin that led to the Gestalt principles of visual organisation.³⁸

One of the theorists involved with Gestaltism, Kurt Koffka, made the following famous statement 'The whole is other than the sum of its parts'.³⁹ In other words, the brain is able to analyse an image and fill in the gaps to recognise the objects and spatial dimensions. This is illustrated by R. C. James' well-known photograph of a Dalmatian dog.⁴⁰ (Figures 31 and 32).



Figure 31.
Ronald C. James *Dalmatian Dog*
Photograph, First published in *Life*
Magazine:58; 7 1965-02-19, p 120



Figure 32.
James' Photograph
edited by Tong-Yee Lee *Innovative Research*
for Illustrative Rendering and Visualization
Techniques Vol 16 issue 5, published:
10/12/2010
By kind permission of the artist

Gestalt principles reveal how we organise visual prompts to recognise objects. Unlike the previous optical cues discussed, Gestalt theory documented cerebral tendencies in the grouping and ordering of objects or forms. The six principles are as follows:

- Similarity
- Proximity
- Continuity
- 'Common Fate'
- Figure and Ground
- Closure

³⁸ Gestalt' something such as a structure or experience that, when considered as a whole , has qualities that are more than the total of all its parts, 'Gestalt', Cambridge Dictionary, <https://dictionary.cambridge.org/dictionary/english/gestalt>, [Accessed 3/01/14]

³⁹ Grace. M. Heider, G.M. (1977). More about Hull and Koffka in *American Psychologist Journal*, vol 32 (5), p 383.

⁴⁰ Ronald. C. James, *Dalmatian dog*, Photograph, *Life magazine*: 58;7 (19 February 1965), p 120.

Similarity Principle

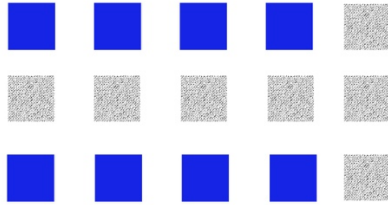

Figure 33.
The Principle of Similarity

The principle of similarity states that things which share visual characteristics, such as shape, size, colour, texture, value or orientation, will be seen as belonging together. The pattern of squares (Figure 33), documents our tendency to put together the blue squares to form two blue groups or strips either side of a sideways grey 'T' shape.

Proximity Principle

The principle of proximity recognises that we group forms or objects together when they are perceived to be close to one another. They are seen to belong together. The image below (Figure 34) illustrates that we see the dots that are closer together as part of one group and the others as in different groups.

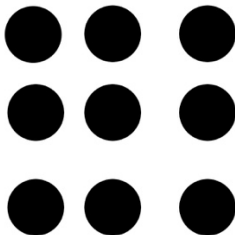

Figure 34.
The Gestalt Principle of Proximity Suggests That You See One Block of Dots on the Right Side and Two Columns on the Left Side

Continuity or Continuation Principle

Continuity works in tandem with the principle of closure, as it recognises that we are more likely to perceive smooth flowing lines and forms than jagged ones. So again, we attempt to link up lines to allow an image to flow, whilst also grouping like forms based on their proximity to one another.

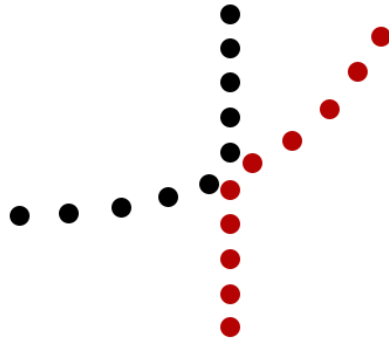

Figure 35.
Steve Bradley *Continuity Principle Diagram* (2010)
Vanseco Design. <https://vanseodesign.com/web-design/gestalt-principles-of-perception>, Accessed 3/03/2014

In Figure 35, due to the colour and grouping of the dots, we see two lines, one black and one red, that bend to touch one another at the centre, as opposed to a straight line down the centre of the group and a curved line which runs through the centre of this.

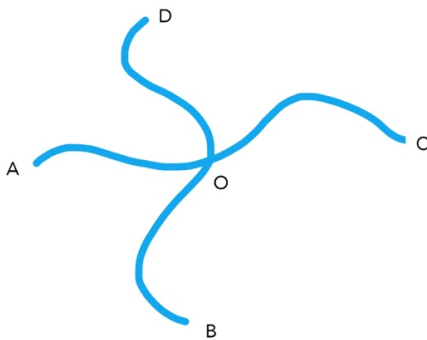

Figure 36.
Good Continuation Principle Diagram

Within Figure 36, the principle of continuity predicts the preference for continuous figures. But here, in what is known as 'good continuation', we perceive the figure as two crossed lines instead of four lines meeting at the centre.

Figure and Ground Principle

Within this principle we find that the brain tends to rationalise our visual world into two parts, the first element being the figure - that is, the object or person that is the focus of the visual field. Next, this is separated from the ground - what is considered the background to this main focal point.



Figure 37.
Edgar John Rubin *Rubin's Vase* (1915)
First published in Rubin's doctoral thesis, *Synsoplevede Figurer*

As *Rubin's Vase* (Figure 37) illustrates, the viewer interprets each image based on their assumptions about what the focus of the image is. The solid nature of the yellow vase form ensures that we consider this as the focus and disregard the background. In the next image, when this background becomes solid through the use of black pigment, this becomes the dominant focus and we see the two figurative profiles clearly.

Esther Stocker's contemporary paintings play with the Gestalt theory of closure in addition to proximity, continuity and figure and ground.

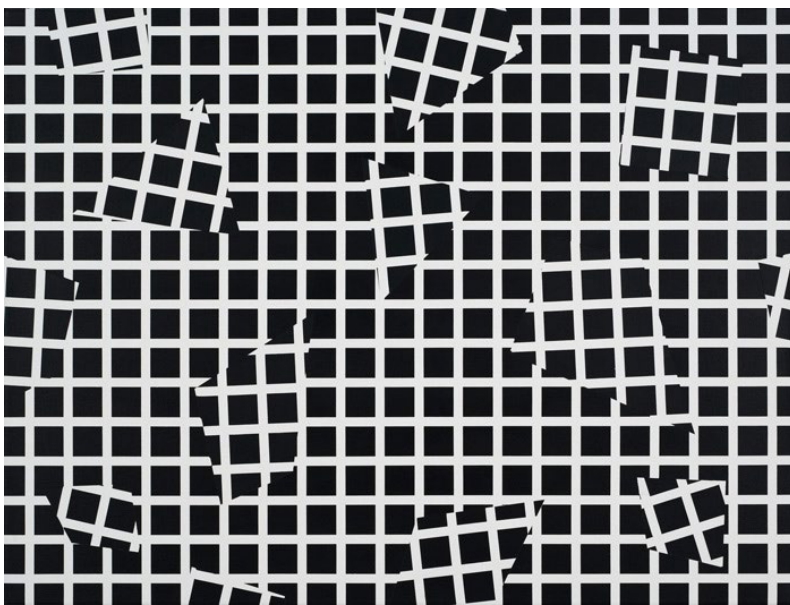

Figure 38.
Esther Stocker *O.T* (2016)
Acrylic on cotton. 60 x 80cm Photography: Meinrad Hofer
By kind permission of the artist

When viewing Stocker's *O.T* (Figure 38), we analyse the main grid using the principle of proximity, grouping all visually similar sections to create a background grid. Then we interpret the non-uniform patterns, which don't conform to this grid, as additional objects on a different plane which sits in front of the base grid, so creating a spatial reference.

This idea that we quickly group and rationalise what we see is adopted in Escher's early watercolours (1898-1972). Here the Gestalt principle of similarity and figure and ground are exploited. Both *Angel-Devil* (No.45), (Figure 39), and *Lizard* (No.25), (Figure 40), create a visual paradox for the viewer. Our brain attempts to group the forms that are similar to enable us to see either one thing or another, i.e. angels, in the case of *Angel-Devil*. Then, as we recognise the alternative space as holding another form, our brain momentarily flicks to interpret the image in a different way, i.e. seeing the devils and losing the recognition of the initial angel form.

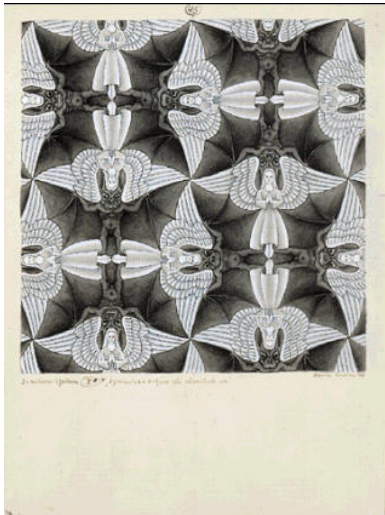

Figure 39.
M. C. Escher *Angel-Devil* (No.45) (1941)
India ink, coloured pencil, white paint. 30
x 22cm
© 2017 The M.C. Escher Company



Figure 40.
M. C. Escher *Lizard* (No.25) (1939)
India ink, pencil, watercolour. 30 x 22cm
© 2017 The M.C. Escher Company

As can be seen in Figure 40, this principle of grouping similar shapes together can be further refined when a change of colour is applied, as here the viewer groups the images together based on colour, even when the shape of the lizard is the same.

This visual paradox is illustrated clearly in Escher's 1938 *Sky and Water I* (Figure 41), which transitions the brain's interpretation gradually from one perception through to the next, from fish to birds. This in particular addresses the Gestalt principle of figure and ground. As with previous Escher works in this chapter, our brain flicks from one recognised grouping to the next as it transitions from its interpretation of the foreground and background of the image to the reverse.

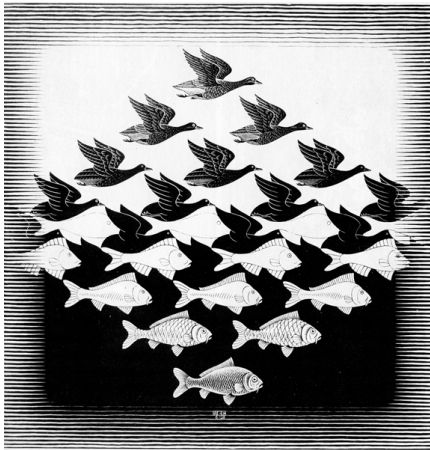

Figure 41.
M. C. Escher *Sky and Water I* (1938)
Woodcut 43.9 x 43.5cm
© 2017 The M.C. Escher Company

Other Gestalt principles build on these starting points.

Common Fate Principle

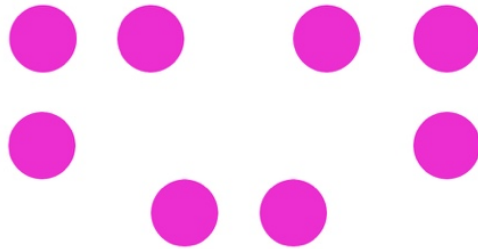

Figure 42.
Common Fate Diagram

In Figure 42 above, imagine the principles of proximity and similarity are in place and then a movement takes place - i.e., the dots begin to move down the page. Now they appear to change groupings.

Closure Principle

The principle which specifies that we are able to complete imagery to make an image whole is known as 'closure'.

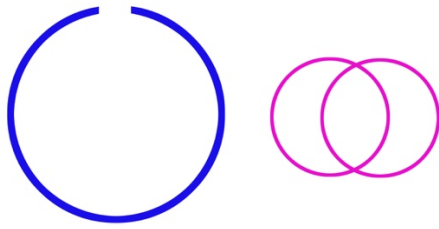

Figure 43.
Closure Principle Diagram

Related to the principle of continuation, there is a tendency to close simple figures, independent of continuity or similarity. This results in an effect of filling in missing information or organising information that is present to make a whole. (Figure 43)

The image below is called a Necker Cube (Figure 44), named after Swiss crystallographer Louis Albert Necker (1786-1861) and first published as a rhomboid in 1832.⁴¹ This simple wire frame rendering of a cube has no visual cues as to its orientation, so can be perceived to have either the lower right or upper left square in its foreground, making it spatially ambiguous. This type of cube is used in visual perception studies. When viewing this image our brain cannot fix on one final interpretation, creating a visual paradox. Next to this image is another version of a Necker Cube, (Figure 45) but this version employs the Gestalt closure principle. Here the viewer fills in the gaps to make the cube whole and places it in front of the black disc-covered background.

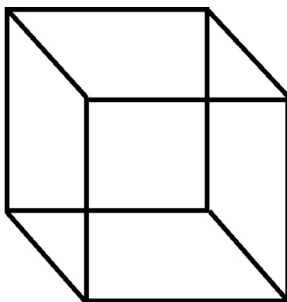

Figure 44.
Necker Cube
School of Computer Science Birmingham
University Website

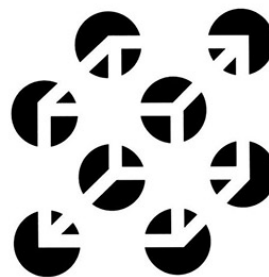

Figure 45.
Necker Cube
UCI, University of California, Irvine

⁴¹ Necker Cube, *The Illusion Index*, <https://www.illusionsindex.org/ir/necker-cube> [Accessed 03/12/15]

The Necker Cube presents the viewer with a familiar, but ambiguous, form which offers object reversibility. That is, it can perceptively shift as the brain attempts to construct a viewing angle, creating a dichotomous paradox and shifting spatial stability.

The Gestalt principle of closure is illustrated in the recent work of contemporary painter Jane Harris. (See Figure 46.)

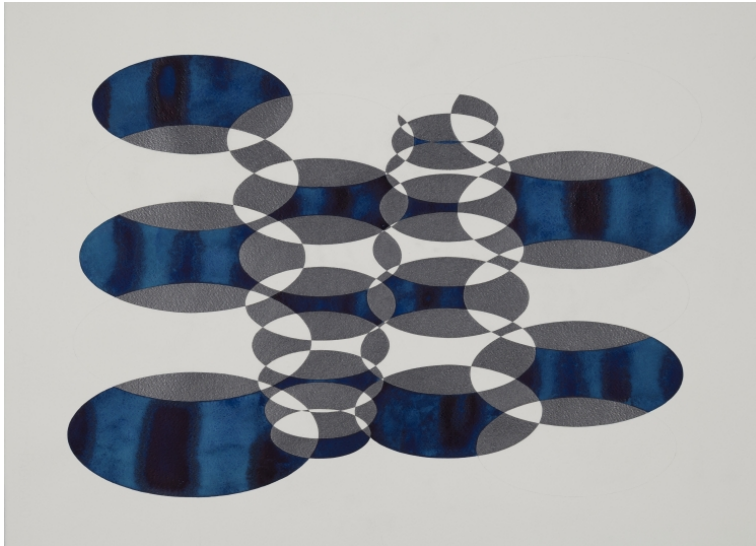

Figure 46.
Jane Harris *Study for Moment of Alignment* (2014)
Watercolour. 56 x 76cm
By kind permission of the artist

Although the imagery used in this composition is neither naturalistic nor representational, it does hold a formal reference, that of an ellipse or circle, and as such is recognisable by our brain, allowing us to complete elements that are absent. This abstract composition also starts to challenge depth perception, as grey overlapping elements sit in front of the blue ovals and the white/plain ground is viewed as background, leading to an optical confusion. Within this work several possible levels can be interpreted, and all overlap, resulting in perceptually indistinct spatial positioning. Tonal reference also adds to the confusion, as darker areas, such as the dense blue colour, are perceived as deeper within the pictorial plane.

These core visual principles indicate how the human brain rationalises optical data in order to make sense of it. As a species which evolved with known predators it is likely that many of these rationalisations are vestiges from our past which created the need to understand the whole, rather than the sum of the parts, when surveying our surroundings. They are a kind of visual short cut, and these, combined with the cognitive visual cues, allow us to create an explanation of what we see before us.

2.5. Optical Art and Illusion

Many artists have exploited the visual cues discussed so far in order to capture a realistic rendering of a scene. In this section I will discuss artworks which purposely exploit all the optical cues discussed above. Here, manipulation of these perceptive cues has led to the creation of works to challenge perception rather than to simply document reality. Pioneered by artists such as Victor Vasarely (1906-1997) and Bridget Riley (b.1931), the 'Optical art' or Op Art movement of the 1960s was driven by a creative interest in exploring perceptual effects.

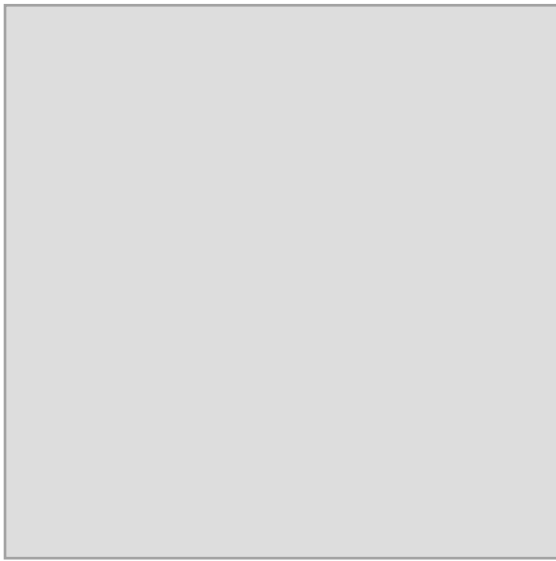

Figure 47.
Victor Vasarely *Gestalt 4* (1970) Silkscreen print. 80 x 80cm

Victor Vasarely, a Hungarian Op Art painter, was an important exponent of this movement, and used geometric forms to create optical effects that challenged the viewer's perception of what they believed they were seeing. In Figure 47 we can see how he has used an understanding of perspective, light and shadow, and interposition to create what on closer inspection is a seemingly impossible form.

Op Art is seen as the successor to Geometric Abstraction, but its investigation into illusion and perception could also indicate that it descended from artistic effects being used as early as 800BC, or 16th-century trompe l'oeil and anamorphosis imagery.

Trompe l'oeil

Trompe l'oeil (French, 'deceive the eye'), aims to convince the viewer that they are looking at reality. As Mari Griffith notes in her 2015 publication, '*trompe l'oeil* makes

us question the boundary between the painted world and ours'.⁴² The earliest reference to this type of work comes from ancient Greece and is a narrative about two well-known artists of the time.

The story goes that Zeuxis painted grapes with such skill that birds flew down to peck at them. Not wanting to be outdone, Parrhasius painted an illusionistic curtain that fooled even the discerning eye of his fellow-painter, who tried to draw it to one side. This famous anecdote was repeated in later art treatises, encouraging artists to emulate their classical predecessors.⁴³

A famous example of this type of illusionistic painting is simply entitled *A Boy Looking through a Casement*, c.1550–60 (Figure 48). Painted by an unknown Flemish artist, the boy appears to be standing behind a leaded window and tapping it to gain our attention. The trompe l'oeil effect here is remarkable, as the figure of the boy sits visually behind an apparent layer of glass. This composition employs a range of optical cues, including interposition, light and shadow and perspective.



Figure 48.
Flemish School *A Boy Looking through a Casement* (c. 1550–60)
Oil on panel. 73.8 x 61.6cm.
Royal Collection Trust/© Her Majesty Queen Elizabeth II 2020

⁴² Mari Griffith. (2015) The Royal Academy of Art, 'Art History 101: What is trompe l'oeil?' <https://www.royalacademy.org.uk/article/art-history-101-trompe-loeil>. [Accessed 18/04/17].Line 7.

⁴³ Ibid

Anamorphosis

Another early illusionistic effect is known as anamorphosis. This is a different perceptual effect by which renderings are abstracted and contorted, making them only recognisable when viewed in a particular way or by using a curved mirror. These images were designed to amaze the viewer whilst showing off the skills of the artist and their understanding of the rules of perspective.

Below are two different examples of this type of anamorphic work. The piece by Samuel van Hoogstraten (1627-1678), a perspective box (Figure 49), plays with our understanding of perspective by creating the illusion of an interior space. To do this he uses anamorphic perspective that, when viewed through the peep-holes provided in the box, enables the viewer to see a much larger and more detailed space than could fit within the box. This 'Tardis'-like effect, which applies rules much like the forced perspective of an Ames Room (pg. 52), leaves the observer confused and enchanted by the work.

In the well-known work by Hans Holbein the younger (1497-1543), *The Ambassadors*, 1533, (Figure 50), the artist has created an extreme perspective image of a skull between the two figures. This can only be viewed as a recognisable skull when the viewer approaches the work from either high on the right side, or low on the left side. (Figure 51).



Figure 49.
Samuel van Hoogstraten *A Peep Show with Views of the Interior of a Dutch House* (c. 1650s)
Oil and egg on wood. 58 x 88 x 60.5cm. © The National Gallery, London



Figure 50.
Hans Holbein the Younger *The Ambassadors* (1533)
Oil on oak. 207 x 209.5cm. © The National Gallery, London

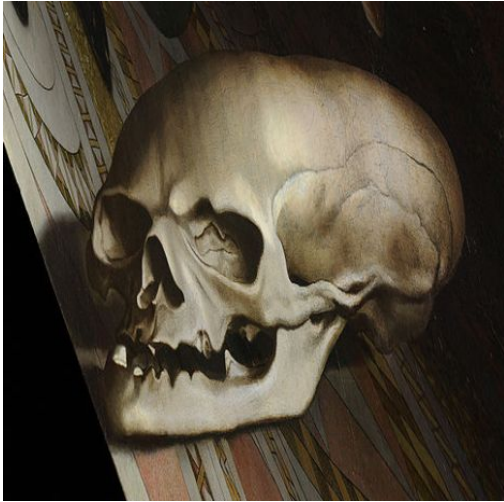

Figure 51.
Thomas Shashan Photograph of The Ambassadors:
High resolution image of the skull, when viewed from the left of the painting
(1953) https://commons.wikimedia.org/wiki/File:Holbein_Skull.jpg

As mentioned above, the techniques of trompe l'oeil and anamorphic perspective were created in order to illustrate the skills and competency of the artist. They can therefore be seen as explorations that analysed and exploited the visual understanding of their time. With this in mind, one can also view the Op art practitioners in this way, as they exploited known physiological and psychological visual cues to create illusionistic works that play with our perception of the pictorial image.

Op Art worked mainly by using purely geometric forms as the basis of its illusionary qualities. It also employed colour theory in addition to the physiology and psychology of perception, creating effects that confuse and disorientate the viewer.⁴⁴ Concerned with how the human eye behaves, as it interprets our perception of an image, the Op Art painters worked with optical phenomena like moiré effects, dazzling and after-images. Initially the use of black and white was dominant. This produced great contrast in the designs, which confused the viewer as they offered no perception of context for the forms by not indicating foreground or background within the composition. As colour was introduced, it gave rise to a play on spatial reference, as, using colour theory, the artists started to bring areas of the composition forward and back, creating further visual contradictions and paradoxes for the brain to attempt to rationalise. Spatial suggestion created by colour was

⁴⁴ Colour theory is both the science and art of using colour. It explains how humans perceive colour; and the visual effects of how colours mix, match or contrast with each other. Colour theory also involves the messages colours communicate; and the methods used to replicate colour. (Kris Decker, 'The Fundamentals of Understanding Colour Theory', *99 Designs*, (2016), <https://99designs.co.uk/blog/tips/the-7-step-guide-to-understanding-color-theory/> [Accessed 12/10/19])

exploited widely in works painted by Vasarely between 1960-1980. See *0519-Bayna* (Figure 52), which uses colour to create spatial levels within the image.

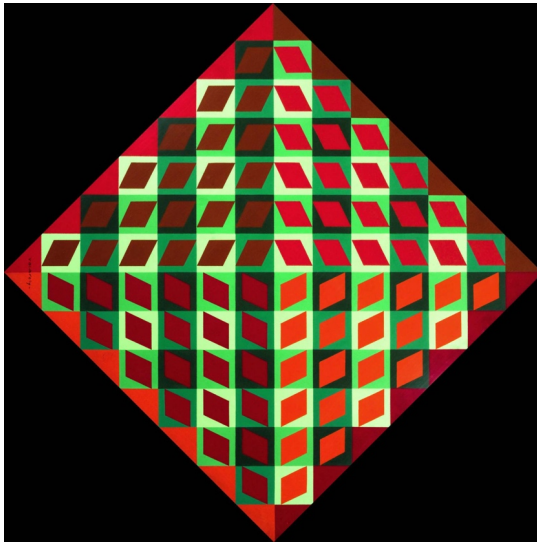

Figure 52.
Victor Vasarely *0519-Bayna* (1964)
Gouache on hardboard. 59.7 x 59.7cm
© ADAGP, Paris and DACS, London 2020

Our understanding of how light falls is played upon here, making the viewer read the images as faceted, with a strong light source directed onto the ridges from the right side of the painting. The direction and hues of orange/red given to the rhomboid shapes also create confusion, suggesting an additional pyramid-like form to the perceived faceted surface. These shapes sit visually on top of the green cubes below, producing a reference to depth which enables the rhomboid forms to float holographically. This work appears to be quite three-dimensional but is in fact a flat two-dimensional painting.

The term 'Op art' may have been first used by the artist and writer Donald Judd (1928-1994), It was first mentioned by Judd in a review he wrote of an exhibition of paintings by Julian Stanczak ('The Art Story', 2017) but for many this term was popularised by an article in *Time* magazine in 1964. This movement came to prominence within the public realm after the exhibition entitled 'The Responsive Eye', at the Museum of Modern Art in New York in 1965. The exhibition consisted of 123 works by artists including Victor Vasarely, Bridget Riley, Frank Stella, Carlos Cruz-Diez, Jesús Rafael Soto, and Josef Albers.

Some art critics also felt that the work from this movement was just a gimmick, and that the phenomenon would be of fleeting interest to the art-buying public. In fact, the commerciality of the images may have led to the movement's demise, as designs were copied and applied to clothing and books. But, although the Op Art movement

had lost mainstream popularity by the late 1960s, the systematic optical effects they worked with are still being explored by artists today.

Even now, long after the Op Art movement's prominence, it is still of interest to contemporary artists who continue to build on the perceptual paradoxes created between the visual data we take in and our perceptual intuition and cognition.

2.6. Optical Depth Perception

Within the human visual system this research is particularly focused on our perception of spatial depth. As mentioned above, the cues that we use to interpret depth and construct our spatial perception are both psychological and physiological. In order to gather the required data to inform these assessments of our surroundings, visual cues are taken which require one eye (monocular vision) or both eyes (binocular vision). The key visual depth perception cues, collated by the eyes, are accommodation, convergence, binocular parallax and monocular movement parallax.

Accommodation - This is the tension of the muscle that changes the focal length of the lens of the eye. As a result, this action brings objects into focus from different distances. This registration is a weak cue given to the brain regarding the distance the viewer is from an object. In terms of my research, this does not give a sufficiently strong reference to allow its manipulation and exploitation via an image, and as such will simply be an additional effect in some cases.

Convergence - Focusing on an object close to us makes our eyes point slightly inwards, so converging. This difference in direction is registered as an effective depth cue for the brain when analysing short distances.

Binocular Parallax - Each of our eyes sees a slightly different view of the world. This difference is called the binocular parallax. The sensitivity of the human visual system recognises these differences, giving the brain its strongest depth cue for medium-distance viewing.

Monocular Movement Parallax - This works using just one open eye and enables us to perceive depth by simply moving our head from side to side. It is thought that this movement of the head enables the capture of images which disclose the larger displacement of nearby objects and smaller displacement of distant objects, facilitating the assessment of spatial depth and distance.

Having examined the depth cues used by the human visual system, for the purposes of my research I chose to work with the stronger depth cues of binocular parallax,

linear perspective and aerial perspective to create optical illusions that challenge the viewer's perception of the image and space within glass.

It is important to point out that the nature and understanding of the mechanisms used in order for us to process and construct our perception is still not totally understood.

...but the process of perception seems to involve at least two inversions: one (optical) inversion of the image on the retina and another (perceptual) inversion that is associated with nerve impulses in the visual tissues of the brain.⁴⁵

Double Vision in Art

In addition, at this stage it is also pertinent to point out another as yet unrecognised depth cue, which I had inadvertently already started to explore in my work prior to this project. This is 'double vision' or 'binocular diplopia'.⁴⁶ ([See Chapter 1.1.](#))

Double vision: The simultaneous perception of two images, usually overlapping, of a single scene or object.⁴⁷

Interestingly I realised that double vision, which was what I was creating, is not recognised by the medical fraternity as an optical cue for depth. (Figure 53)

⁴⁵ E Jaakko Jarvinen, Pekka Yrjo Korkala and others, 'Space Perception', in *Encyclopedia Britannica*, (May 22nd, 2017.) <https://www.britannica.com/science/space-perception/Visual-factors-in-space-perception> [Accessed 05/04/19]

⁴⁶ 'Double Vision', Conditions, NHS, September 2017, <https://www.nhs.uk/conditions/double-vision/> [Accessed 06/01/18]

⁴⁷ Ashleigh McGorlick, 'Double Vision (Diplopia): Causes, Symptoms and Treatment'. *Eye5*, 23 Oct 2015. (online). <https://eye5.com.au/eye-care/diplopia-double-vision/> [Accessed 15/10/18]



Figure 53.
Helen Slater Stokes *Field View* (2019)
Cast glass and enamel. Dimensions: 13cm diameter x 4cm deep

In fact, this is known as an optical condition, or defect, as it is not the visual norm. Further research into double vision as a depth cue revealed David Hockney's theory articulated in his book *Secret Knowledge: Rediscovering the Lost Techniques of the Old Masters*.⁴⁸

Hockney believed that Paul Cézanne (1839-1906) was the first artist to recognise that, as humans with binocular vision, we actually see two different aspects of an object or scene. He was intrigued by the fact that when attempting to capture an object or scene in art we only convey the resolved singular image created by our brain, the perceived image. Hockney suggests that this led to Cézanne's experimentation with methods to visually capture the world as we 'naturally' see it, natural vision being two disparate monocularly gathered images that combine or fuse to create one picture, conveying a sense of spatial depth. (See Figure 54)

⁴⁸ David Hockney, *Secret Knowledge: Rediscovering the lost techniques of the Old Masters*, (2006), New and Expanded edition, (London: Thames & Hudson, 2006)

Hockney argues that 'Cézanne's innovation was that he put into his pictures his own doubts about how the objects related to himself, recognising that viewpoints are in flux, that we always see things from multiple, sometimes contradictory, positions'.⁴⁹



Figure 54.
Paul Cézanne *Still Life With Apples* (c. 1878)
Oil on canvas. 19 x 27cm © Fitzwilliam Museum, Cambridge

It is clear, as Hockney suggests, that Cézanne's use of mark and paint application begins to suggest form and depth by almost carving out the objects depicted. This approach challenges the earlier more photographic depictions, such as *Basket of Fruit*, (Figure 55), by Michelangelo Merisi da Caravaggio (1571-1610), which by comparison appears to be fixed on one plane within the composition, very much as a detailed two-dimensional illustration, rather than moving spatially between the foreground and background of the work.

⁴⁹ Ibid. p190-191.



Figure 55.
Michelangelo Merisi da Caravaggio *Basket of Fruit* (1597–1602)
Oil on canvas. 31 x 47cm
© Biblioteca Ambrosiana, Milan

There is no doubt that this is an accomplished illustration of a basket of fruit by Caravaggio, but spatially its head-on, eye-level composition and lack of background gradation creates the illusion of a single plane. The basket appears collaged onto the background and has a minimal depth, as each piece of fruit or foliage appears equally sharp and in focus.

Other artists have certainly looked at the use of multiple imagery to convey the facets of an image. Pablo Picasso (1881-1973), in his Analytical Cubist⁵⁰ period, was said to have studied Cézanne's later paintings, which shifted perspective seemingly in an attempt to mimic the artist's investigation of the objects from differing angles. Picasso's *Portrait of Ambroise Vollard* illustrates this interplay between viewpoints. (See Figure 56)

⁵⁰ The term analytical cubism describes the early phase of cubism, generally considered to run from 1908–12, characterised by a fragmentary appearance of multiple viewpoints and overlapping planes. ('Analytical Cubism', Tate Gallery, <https://www.tate.org.uk/art/art-terms/a/analytical-cubism> [Accessed 19/01/19])



Figure 56.
Pablo Picasso *Portrait of Ambroise Vollard* (1910)
Oil on canvas. 92 x 65cm
By permission of the Pushkin State Museum, Russia

Although Picasso's Cubist approach certainly gives the viewer various angles of a scene or object, this work doesn't necessarily create, or engage in, a visual dialogue around depth perception. Here the tonal reference of the work is more effective in creating a central depth in the composition, as lighter tones gradually transition to a darker central area around the face.

Ongoing investigations into the use of double imagery to create depth unearthed the work of the little-known Welsh artist Evan John Walters (1893-1951), and it is his research that resonates mostly closely with my own investigations.

Walters was known for his traditional and proficient paintings of Welsh life.⁵¹ But, whilst sitting by the fire one evening, he is said to have had a visual revelation. As he stared vacantly into the flames, he became aware of perceiving a double representation of his shoe in front of him. Walters realised then that if painting was to compete with photographic developments of the time it must depict a natural vision of what, as humans, we see. Through his experiments and research, he acknowledged that these renderings, created by painting individually what each of the eyes see on the same canvas, created a sense of three-dimensional depth and space. (See Figure 57)

⁵¹ Barry Plummer, *Evan Walters: Moments of Vision*. (Wales: Seren publishing, 2011)



Figure 57.
Evan Walters *Stout Man with Jug* (c. 1936)
Oil on canvas. 76 cm x 92.1cm Glynn Vivian Art Gallery, Swansea ©The
artist's estate By permission of Bridgeman Images Ltd

Scientists Pepperell and Ruschkowski⁵² explain this phenomenon as follows:

In normal vision, the fused images contribute to the phenomenon of stereopsis, which is often described in terms of enhanced sensation of depth. In fact, only 5% of the total visual field is fused (Agrwal and Blake, 2010⁵³). Objects seen outside this point of fusion, and beyond a zone of tolerance known as Panum's fusional area,⁵⁴ will appear doubled due to the images being located at different points on the retinae of each eye. Double images will also generally appear less distinct as they are seen in the peripheral field or outside the point of focus (Ogle 1964).⁵⁵

Pepperell and Ruschkowski's 2013 paper *Double Vision as a Pictorial Depth Cue* is one of few texts addressing this phenomenon within optical perception. Their conclusion neatly sums up this concern:

⁵² Pepperell, Robert & Ruschkowski, Anja, 'Double Vision as a Pictorial Depth Cue', *Art & Perception* 1.1 (Feb 2013), 49-64 h. p.54

⁵³ Agarwal, A. and Blake, A. (2010). Dense stereo matching over the Panum Band, *IEEE T. Pattern Anal.* 32, 416-430

⁵⁴ Panum's fusional area is the area on one retina such that any point in it will fuse with a single point on the other retina.

⁵⁵ Ogle, K. N. (1964). *Researches in Binocular Vision*. (New York: Hafner Publishing Company, 1964)

The use of double vision as a pictorial depth cue has received very little attention in art or science. Yet the results obtained here suggest that under certain conditions double images may have significant impact on perceived depth in pictures. Much further work is needed to replicate these results, to determine the possible impact of other variables, and better understand the perceptual phenomenon itself.⁵⁶

Interestingly, this principle, of fusing together a combination of images around a key focal point, is one which is utilised when creating three-dimensional lenticular images. When originating a three-dimensional lenticular image using a photographic or digital medium, one must decide on a focal point within the three-dimensional composition and use this to anchor the images which are taken from a range of angles/viewpoints, together. This focal point is set in the middle ground of the three-dimensional design and remains visually static once the images are interlaced and meshed to a lenticular lens. This is something that I will discuss in further detail in [Chapter 5.6](#).

⁵⁶ Robert Pepperell & Anja Ruschkowski, Double Vision as a Pictorial Depth Cue, *Art & Perception* 1(1):49-64, Feb 2013, https://www.researchgate.net/publication/267097579_Double_Vision_as_a_Pictorial_Depth_Cue [Accessed 03/04/14]. p 62.

3. Glass Artwork and Optical Perception

Thus far I have addressed the use of optical cues within selected historical and contemporary artworks, excluding artists working in glass. This chapter aims to analyse this specialist area and the variety of additional illusionistic qualities that this material offers.

It is important to emphasise that, with regard to the artworks discussed previously, these artists were predominantly working on the perceived translation of a two-dimensional surface-based image or pattern into three dimensions.

All visual art is illusory in that it involves a departure from reality, a filtering through the mind of the artist. This subjectivity applies not only to abstract works but also to representational art, in which the artist translates his or her perception into a physical object capable of inducing a similar perception in the viewer.

Painters render the three-dimensional world on a flat surface. These representations are enough to suspend our visual system's disbelief and trigger barrages of neuronal firing that become visions of bathers, bridges and water lilies. It is never about reality but about how the artist sees and wants to portray it. This artistic vision is a mishmash of expectations, memories, assumptions, imagination and intent. It is also, in a sense, a reflection of neural shortcuts and basic visual processes.⁵⁷

When analysing the use of these optical triggers and other techniques to create three-dimensional or spatial references in glass artworks, it is important to recognise the additional attributes and qualities this material affords.

3.1. The Visual Characteristics of Glass

Glass as a material has key characteristics which can be exploited to create spatially, optically challenging and illusionistic work. First, it is a solid transparent material. Glass is a special type of solid, known scientifically as an amorphous solid. This means that within this material the atoms and molecules are locked into place,

⁵⁷ Stephen Macknik & Susana Martinez-Conde, *Sights of Mind: What the Neuroscience of Magic Reveals about Our Everyday Deceptions* (New York: Henry Holt and Co., 2010). p2.

Exploring the Optical Perception of Image Within Glass

creating a solid, but these do not form methodical crystal patterns. Within glass these molecules and atoms are randomly arranged, and this results in a material that is rigid, but which has an atomic and molecular structure more closely related to a liquid.

Glass is transparent in what is termed as visible light. This is light that is visible to the human eye.

...our eyes are sensitive to a very narrow band of frequencies within the enormous range of frequencies of the electromagnetic spectrum. This narrow band of frequencies is referred to as the visible light spectrum. Visible light - that which is detectable by the human eye - consists of wavelengths ranging from approximately 780 nanometres (7.80×10^{-7} m) down to 390 nanometres (3.90×10^{-7} m).⁵⁸

When the smallest particles of visible light, photons, interact with the atomic and molecular configuration of glass, the electrons which are attached to the atoms can vibrate.

It is often useful to think of these electrons as being attached to the atoms by springs. The electrons and their attached springs have a tendency to vibrate at specific frequencies. Similar to a tuning fork or even a musical instrument, the electrons of atoms have a natural frequency at which they tend to vibrate. When a light wave with that same natural frequency impinges upon an atom, then the electrons of that atom will be set into vibrational motion. During its vibration, the electrons interact with neighbouring atoms in such a manner as to convert its vibrational energy into thermal energy. Subsequently, the light wave with that given frequency is absorbed by the object, never again to be released in the form of light. So, the selective absorption of light by a particular material occurs because the selected frequency of the light wave

⁵⁸ Tom Henderson, 'Visible Light and the Eye's Response', <http://www.physicsclassroom.com/class/light/Lesson-2/Visible-Light-and-the-Eye-s-Response>, [Accessed 27/04/18].

matches the frequency at which electrons in the atoms of that material vibrate.⁵⁹

Artistically the notion of light passing through glass allows a further visual dimension. As Caitlin Hyde, glass designer and lecturer at Corning Museum of Glass, writes:⁶⁰

This characteristic creates...
...an enhanced relationship with light because of the range of transparency to opacity that is potential in the material.

The translucency of glass, allowing more or less light to pass through it, creates the possibility of intriguing works, mysterious depths and illusionistic focal points.

Varying the levels of translucency in glass allows an artist to modulate the viewer's experience of light in relationship to form in an object, evoking emotional response through the material.⁶¹

It is important to note that not all glass is transparent. Opaque glass does not allow light to pass through it: this can be due to a variety of additions to a base transparent glass recipe; the addition of impurities, ingredients such as metallic oxides or melt contamination.

For example, '[...]"black bottle glass" was a dark brown or green glass, first produced in 17th-century England. This glass was dark due to the effects of the iron impurities in the sand used to make the glass and the sulphur from the smoke of the burning coal used to melt the glass.'⁶²

Also, the intentional colouration of what is known as 'milk glass', a semi-transparent or translucent glass, and manufactured smoked glass is achieved by adding tin oxide to a base of clear glass. These accidental impurities or intentional additives change the structure of the electrons within the opaque material. In this instance, when visible light waves with the same frequency as the material's electrons enter the

⁵⁹ Tom Henderson. 'Visible Light and the Eye's Response', <http://www.physicsclassroom.com/class/light/Lesson-2/Visible-Light-and-the-Eye-s-Response>, [Accessed 16/04/18].

⁶⁰ Caitlin Hyde, 'Transparency & Light in Glass & Art', *Corning Museum of Glass* [blog post], (Feb 2015), <https://blog.cmog.org/2015/02/18/transparency-light-in-glass-art/> [Accessed 21/04/17].

⁶¹ Ibid.

⁶² Anne Marie Helmenstine, *The Chemistry of Coloured Glass*, 2017. <https://www.thoughtco.com/the-chemistry-of-colored-glass-602252> [Accessed 4/12/18]

material, they cause the electrons to vibrate rapidly and absorb the light as it is converted into thermal energy.

In addition to transparency and translucency, glass is refractive. As a light ray passes through the material the ray deviates slightly from its original path. This effect is known as refraction.⁶³ All materials can be measured in terms of the degree of deviation the trajectory of a light ray has when it passes through. This is called the material's refractive index.

The refractive index of glass also offers more creative possibilities, as its surface can be polished and reshaped to generate lenses and surface angles which distort the light passing through and the perceived images, colours and angles within it.

Finally, glass is reflective. Highly polished surfaces allow the reflection of the object's surroundings within the object. When considering reflection in glass, it is important to note that although visible light is transmitted through glass, a small proportion of this is also reflected. The degree of reflection depends upon the angle at which the light enters the glass. Internal reflection can also be produced in glass, so that internal colour or image can be projected or bounced internally within the form of the glass.

Because of its transparency, high refractive index and reflective qualities, glass offers a myriad of illusionistic possibilities, but within this thesis I am particularly interested in spatial and depth perception. Throughout this chapter the works I will be discussing utilise and manipulate these characteristics, adding further dimensions to the optical cues and geometric illusions analysed earlier. These works create a discourse that supersedes the boundaries of simple optical cues and illusionist trickery, as emotive response and physical interaction push the observer's concept of spatial perception.

3.2. Transparency and the Image

The first attribute which makes glass unique as a material is how light reacts with it, giving it the ability to be transparent, translucent or opaque. The infinite nuances of these material characteristics enable artists to develop their own unique visual language whilst exploring and communicating their personal conceptual interests.

⁶³ Refraction -The fact or phenomenon of light, radio waves, etc. being deflected in passing obliquely through the interface between one medium and another or through a medium of varying density. ('Refraction', *Oxford Dictionaries*, <https://en.oxforddictionaries.com/definition/refraction>. [Accessed 19/04/18])

Exploring the Optical Perception of Image Within Glass

The first artist whose work is of interest in this context is Jeffrey Sarmiento. Sarmiento produces glass works employing a purist understanding of the perception of the image in glass. In a wide range of sculptural works Sarmiento has exploited the optical qualities of glass, playing with subtleties of distortion, magnification, refraction and focus when incorporating imagery within the glass. These pieces use the vehicle of glass to impart Sarmiento's personal approach to ethnicity and belonging.

In his early work *Natives* (Figure 58), Sarmiento overlays photographic imagery on opaque glass, creating a ghosted image similar to a double exposure on photographic film. Optically this poor-quality photographic image, based on off-white opaque glass, communicates an archive-like reference. The visual condition and overlaying of this double image leads to confusion within this small work: nevertheless, we understand that this is a family group photograph. As in many of Sarmiento's pieces he relies on our ability to recognise the imagery before us and bring with this cognition our own associations.

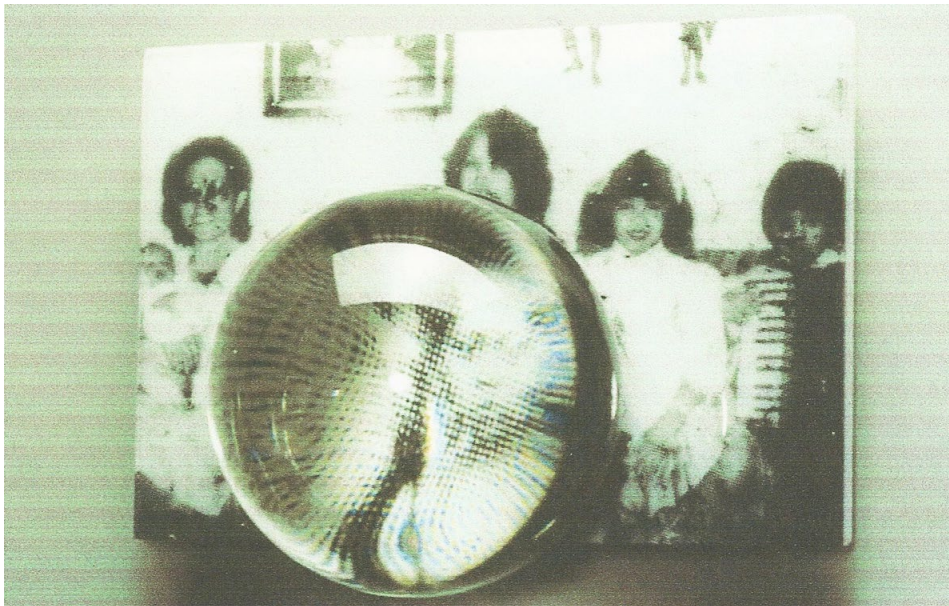

Figure 58.
Jeffrey Sarmiento *Natives* (2002)
Enamelled and kiln formed glass with hot-formed sphere. 21 x 13 x 8cm
By kind permission of the artist

Visually the sandwiching of these two images behind clear glass appears to bind them together, almost as if in a traditional pictorial frame, creating the impression that this unity of image was captured at the time the portrait was taken. To this imagery Sarmiento adds a glass half-dome, creating a magnification point on the image and drawing the viewers' attention to this area. The depth in this work is

generated by this glass half-sphere, which creates a convex⁶⁴ lens. 'A convex lens is also called a converging lens because it makes parallel light rays passing through it bend inward and meet (converge) at a spot just beyond the lens, known as the focal point.'⁶⁵

Light rays from the object enter the glass in parallel but are refracted by the lens so that they converge as they exit and create a 'virtual image' on the retina of your eye. This image appears to be larger than the object itself because of simple geometry: Your eyes trace the light rays back in straight lines to the virtual image, which is further from your eyes than the object is and thus appears bigger.⁶⁶

The imagery is taken from one of Sarmiento's own family photographs and is combined with imagery of what he describes as 'Filipino savages'. It speaks of the enduring prejudice of racial stereotyping and Sarmiento's own perception of his ethnicity as a Filipino immigrant in America.

The subject of the imagery is intriguing, and as Sarmiento stated in 2011:

My early artworks were a deliberate attempt to expose negative perceptions of my ethnicity. [...] *Natives* uses a glass sphere as a lens to interrupt an old family snapshot of my Filipino immigrant family with a historical image of Filipino 'savages'.⁶⁷

Conceptually, the use of the glass lens in this work, in addition to interrupting the imagery, magnifies a focus on the pixelated portrait of Sarmiento within the group, reflecting his own deep self-analysis within the work.

⁶⁴ 'Convex' – Having a surface this is curved or rounded outwards. 'Convex', Dictionary.com. <http://www.dictionary.com/browse/convex>, [Accessed 20/04/18]

⁶⁵ Chris Woodford, 'Lenses', *Explain that stuff*, <https://www.explainthatstuff.com/lenses.html> [Accessed 25/04/19]

⁶⁶ Mike Crystal, 'How do Magnifying Glasses Work?' *Sciencing*, (April 24th, 2017), <https://sciencing.com/magnifying-glasses-work-4567139.html> [Accessed 12/10/18]

⁶⁷ Jeffrey Sarmiento, *Graphic Glass: Development of Creative Approaches to Expressions of Ethnicity*. (Unpublished PhD thesis, University of Sunderland, 2011), p.16



Figure 59.
Jeffrey Sarmiento *Triple Self Portrait* (2007)
Screen-printed, cut and fused glass. 42 x 30 x 1 cm
By kind permission of the artist

Triple Self Portrait (Figure 59) is an intriguing piece which clearly explores the generational heritage of Sarmiento's family roots.

Once again, using photographic imagery Sarmiento takes halftone portrait images of his grandfather, his father and himself (the artist) and slices these into strips, interweaving them to create an image that we recognise as a portrait but which from certain angles begins to distort as features disappear and appear. There is a perceived shallow spatial depth to this work, but it is an unstable one that jars the eye as the viewer attempts to find a focus on the imagery.

The quality of the photographic schemata adds a 'vintage' feel to the work and echoes past references with its language of nostalgia. But this is not a comfortable nostalgia. Through the power of suggestion, we read the piece as a traditional portrait. We recognise the image as a portrait, but the refractive qualities of the glass add a visual confusion and negative ambiguity to the perceived image. This disturbing conflict shifts as glimpses of one image are seen and then lost, and then elements of another re-emerge. Visually this work seems to act as a metaphor for Sarmiento's struggle to find his personal identity amongst the complex dynamics of being a second-generation Asian immigrant.

Multiple physical layers of depth, created by screen-printing images onto sheets of glass, is something that Sarmiento employs regularly. In his *Encyclopedia* series (Figure 60) he lays images upon one another, creating linear references to a collage of found imagery, iconography and text. Again, optically we are visually confused,

bamboozled by a barrage of overlaid images. The depth within these works is a physical one, that doesn't rely on illusions of space but on our perception of the image-based metaphors encased.



Figure 60.
Jeffrey Sarmiento *Encyclopedia (Volumes)* (2010–13)
Printed and kiln formed glass. 21 x 15 x 5cm each
By kind permission of the artist

These blocks each appear to convey a reference to personal identity, knowledge and ethnicity. The glass, as a material, references the fragile nature of this busy marriage whilst allowing the viewer to clearly see each layer of imagery and pattern. Here the viewer is left to attempt to connect the visual synergies between the different kinds of subject matter. Of course, it could be argued that this work could have been carried out in resin, but the weight of these combined pieces and the optical quality of the glass adds a clarity and gravitas to the work, hinting at the complexity and physical weight of knowledge.

Unlike Sarmiento's ethnographic⁶⁸ approach, working with photography and found imagery, Jeremy Lepisto employs a more illustrative, hand-drawn style in his work.

Lepisto has worked in glass since his graduation from Alfred University, New York, in 1997, and during that time has gained experience working with both the technical and artistic sides of glass production. His pieces are again produced using layered imagery, allowing the communication of a physical and conceptual depth, but his clever use of the material's colour, transparency and translucency enables him to allude to objects and particular places within an almost melancholic language.

⁶⁸ 'Ethnographic' – relating to the scientific description of peoples and cultures with their customs, habits, and mutual differences.

Building Up (Figure 61), in Lepisto's *Watertower* series, utilises the colour of the blown glass to suggest evening sunset. This evokes feelings of nostalgic reflection, perhaps as a reference to the wane of heavy industry in this part of America, or, as the title suggests, to the start of regeneration. Observed in either way, the viewer gains a warm feeling about the location, a positive, optimistic yet wistful association.



Figure 61.
Jeremy Lepisto *Building Up* (2008)
Blown and enameled glass with metal
43.2 x 16.2 x 16.2cm By kind permission of the artist

The imagery, preserved within a form which physically references a water tower, allows the viewer to survey the industrial landscape through 360 degrees, looking through and past foreground buildings or everyday objects and generating a stage set or tunnel book-like optical effect.⁶⁹ Our eyes register the recognisable urban landscape and instinctively assimilate visual interposition cues to set these engineered schemata within a spatial context.

The detail, and gradation of tone and texture, draws one visually into this captured world. Lepisto's clever use of layered, fired and cold-worked painted imagery produces tonal variations, when looking through the front wall of the cylinder, that add aerial perspective-based depth to the vignette. In a similar way to Antony Gormley's aquatint *Matrix V*, (Figure 62), the tonal transparency of Lepisto's images

⁶⁹ Tunnel books are made up of a series of pages that are held together by folded strips of paper on each side. The overall effect of a tunnel book is to create the illusion of depth and perspective. ('What Is a Tunnel Book? *Wonderopolis*, <https://wonderopolis.org/wonder/what-is-a-tunnel-book>. [Accessed 19/05/18])

builds up as you look through the surfaces, allowing the brain to construct a recognised space and context.

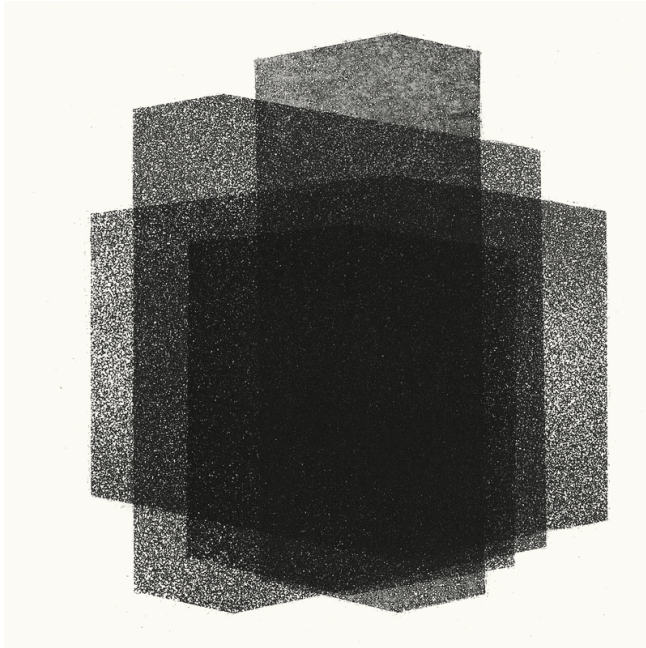

Figure 62.
Antony Gormley *Matrix V* (2017)
Aquatint. 32.2 x 32.2cm
© Antony Gormley. All Rights Reserved.

The eye is not at all confused, but rather convinced by what it is seeing. There is a comprehension of a foreground, middle and background that communicates depth as one moves around the object's imagery. Its tonality, texture and scale are as convincing as a two-dimensional illustrative sketch or charcoal drawing. This is a familiar pictorial illusion, but what is added to this understanding and exploitation of the optical cues is the preserving quality of the glass and the form in which these principles have been adopted. The archive-like preservation of particular places and the capturing of a given moment in time are obviously central to these works.

As Lepisto states on his website, 'The works in the *Watertower* Series contain and preserve the idea of the environments from where they could be found.'⁷⁰

In 2009 Lepisto relocated to Australia, and perhaps the transience and recollection communicated within these pieces relate to memories of his life in America. Certainly, the relationship that Lepisto's piece *Reach* (Figure 63), has with this dislocation is instantly recognisable. This work, one of the *Crate* series, offers a

⁷⁰ 'Selected Works for the *Watertower* series', *Jeremy Lepisto*, <https://www.jeremylepisto.com/watertower-series.html>, [accessed 15/10/2015]]

discourse on 'the want for goods that are un-order-able, un-receivable and/or undeliverable.'⁷¹



Figure 63.
Jeremy Lepisto *Reach* (2011)
Kiln formed and assembled glass with enclosed found object.
63.5 x 42 x 60cm By kind permission of the artist

Here the constructed glass crate has been frosted, giving it a soft translucency and creating a diffused perception of the object within. Out of focus, as though out of reach, what appears to be a ladder is unobtainable but present. Again, this tonal softening adds mystery and gives the object and space an intangible physicality. It is not just one area of the piece which is blurred, allowing the artist to control the viewer's focus: it is the entirety of the work.

As mentioned previously, artists have frequently used a soft focus or a blurring of the image to construct associations for the viewer. In relation to his blurred 'photopainting'.series, Gerhard Richter stated '[...] I blur to make everything equal, everything equally important and equally unimportant.'⁷²

In Lepisto's work, this ensures that the specifics of the black form drop away, and one starts to think about the work as a whole, rather than what it optically depicts. It also begins to make the observer aware of the act of looking, by momentarily straining to perceive the object within.

The ladder is also contained within the crate, trapped, inaccessible, 'out of stock'. Once again it appears that this crate is a metaphor for travel. The preservation of

⁷¹ Jeremy Lepisto, <https://www.jeremylepisto.com/crate-series.html>, [accessed 15/10/2015]

⁷² Tom McCarthy, 'Blurred Visionary: Gerhard Richter's Photo-paintings', *Guardian* (22 Sep 2011), <https://www.theguardian.com/artanddesign/2011/sep/22/gerhard-richter-tate-retrospective-panorama> [Accessed 10/02/15]

something now unobtainable within communicates feelings of dislocation and transition. That said, these works are seemingly a calm and considered synopsis of Lepisto's life. They offer an elegance and accuracy that visually reference logical, methodical approaches to imparting these psychological concerns.

Wilfried Grootens is a contemporary German glass artist who also works with layers of glass to produce complex imagery, but this time the layers, rather than imposing themselves upon one another, work in harmony to convey a solid form encased within the glass. In Grootens' creations the imagery is painstakingly hand-painted onto each individual sheet of glass. This approach is founded in his initial training with glass as a restorer of antique painted stained glass windows. Unlike Lepisto's illustrative work, with its delicately tonal floated images and soft visual transitions, Grootens creates an unyielding solid space within the glass. His opaque abstract forms have a denseness and substantial presence. These suspended three-dimensional illustrations are, perhaps as some of the titles imply, reminiscent of as yet undiscovered marine life or preserved biological specimens. (Figure 64)

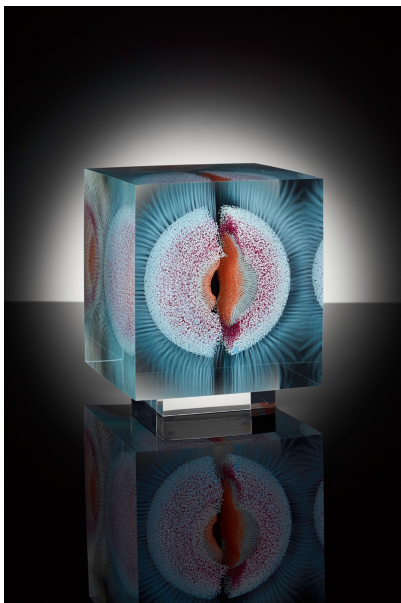

Figure 64.
Wilfried Grootens *Anemon* (2015)
Optical glass, painted, laminated, polished. 22 x 22 x 22cm
By kind permission of the artist

These otherworldly depictions are visually compact but incredibly delicately painted. And, unlike Sarmiento and Lepisto, Grootens chooses to glue this work rather than kiln-fire it as an assembly process. All of this ensures that the absolute precision adopted in the painting of these works by hand is unaffected as the work is constructed.

Thin clear sheets of glass have very fine brushwork added to them, giving a variety of tone, size and colour to each layer. To create the illusion of a consistent form, each of these circles must expand or reduce in scale gradually to gently convey the illusion smoothly. Here Grootens is working as if this specimen has been biologically sliced into thin layers, giving the work an almost scientific feel but one which is visually disguised on construction by the organic, free-flowing brushmarks.

Because of what appears to be a very strict attention to detail in these works, one could imagine that they might appear sterile, but these pieces are anything but. The fine brushstrokes add finesse and an animation to the painted forms that allude to captured specimens in liquid-filled jars or a medical depiction of the inner workings of the eye.

Here the glass allows the viewer to look through the layers, perceptually assembling these individual two-dimensional illustrations into three-dimensional forms. When looking at the front face of the block we are convinced of the solid form within, and cognitive resemblances to a sea urchin and anemone enhance this belief. The depth created by this imagery is not illusionary, as the layers of glass amount to the optical thickness of the work itself. But the illusion is in our understanding of what is within, what this imagery is. The brushmarks aren't read as such: independent, illustrative and graphic, they are a credible unified mass. They have become three dimensional. Ocular perception cues of closure,⁷³ proximity⁷⁴ and continuation,⁷⁵ part of the Gestalt theory, are employed by the brain to assemble this convincing argument.

But there is one optical surprise to come. As the observer walks around the piece, due to the construction methods the thickness of the assembled float glass is now on show and when the viewer stands square on to the side of the work the mesmerising imagery disappears in a flash, as if by magic, leaving no trace, turning from a dense substantial depiction of a three-dimensional form to a void. (Figure 65)

⁷³ The principle of closure applies when we tend to see complete figures even when part of the information is missing. Our minds react to patterns that are familiar, even though we often receive incomplete information. It is speculated this is a survival instinct, allowing us to complete the form of a predator even with incomplete information. (Bonnie Skaalid, 'Gestalt Principles: Closure, Area and Symmetry', *University of Saskatchewan*, <https://etad.usask.ca/skaalid/theory/gestalt/closure.htm>) [Accessed 19/01/18].

⁷⁴ The principle of proximity describes how the human eye perceives connections between visual elements. Elements that are close to each other are perceived to be related when compared with elements that are separate from each other. (Mads Soegaard, 'Laws of Proximity, Uniform Connectedness and Continuation: Gestalt Principles 2', *Interaction Design Foundation*, <https://www.interaction-design.org/literature/article/laws-of-proximity-uniform-connectedness-and-continuation-gestalt-principles-2>) [Accessed 19/01/18].

⁷⁵ The law of continuity holds that points that are connected by straight or curving lines are seen in a way that follows the smoothest path. Rather than seeing separate lines and angles, lines are seen as belonging together. ('Gestalt Laws of Perception', *Verywellmind*, <https://www.verywellmind.com/gestalt-laws-of-perceptual-organization-2795835>) [Accessed 19/04/18]]

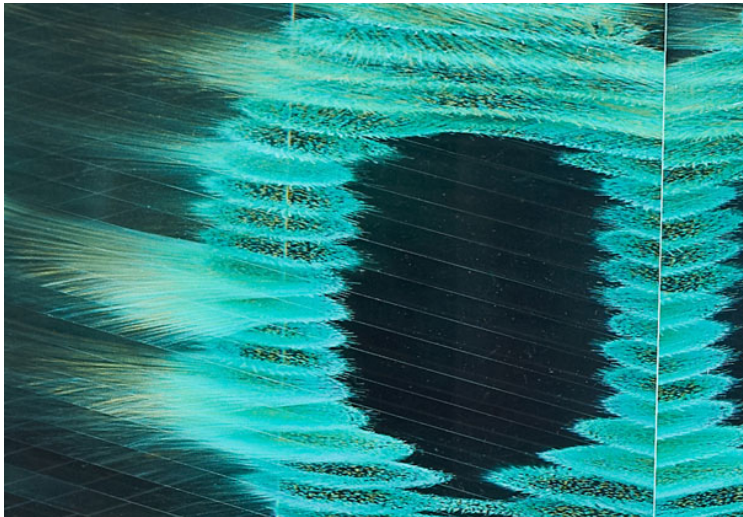

Figure 65.
Wilfried Grootens *Where the Shark Bubbles Blow* (Detail) (2012)
Optical float glass, painted, laminated, polished. 24 x 22 x 22cm
By kind permission of the artist

In the 'in between', as the piece is observed at an asymmetric angle, the painted form is internally reflected within the highly polished planes of the cube, partially duplicating the image and showing reflections of the back and side of the form.

Grootens' *Dream Carrier* (Figure 66) captures these reflective illusionary qualities, as the glass internally reflects differing viewpoints of the painting onto its internal walls, creating a separation of the constructed image and playing with the familiarity of glass as a mirror, reflecting the darker underside of the form in the segments below. This dissection of the complete form proves more challenging to the viewer than the seemingly solid suspended organism within the block in the earlier works. Here the viewer sees combined viewpoints simultaneously reflected within the highly polished optical glass, resulting in a struggle to determine what they are looking at.



Figure 66.
Wilfried Grootens *Dream Carrier* (2017)
Painted, glued, polished glass. 50 x 22 x 22cm
By kind permission of the artist

Exploring the Optical Perception of Image Within Glass

The final work by Grootens that is of interest here moves away from his familiar cube forms to a more organic pod-like shape. (Figure 67)



Figure 67.
Wilfried Grootens *Small Cosmic Efflorescence 1* (2016)
Painted, laminated and polished glass. 30 x 30 x 48cm
29.85 x 29.85 x 47.63cm
By kind permission of the artist



This piece is constructed in the same way as the cube pieces, but here the imagery is painted onto discs of glass cut precisely to allow the form to narrow and widen, creating a pod-like shape when assembled. As a result of the transition of the length and form, from a narrow state to a bulbous middle and back, this work creates a new visual surprise.

The gradual approach of the viewer along the length of the work allows the painted image to appear and disappear in sequence, creating an animated rippling of colour down the length of the glass. Once again, when absolutely square on to the side of the work the image disappears, but then on moving it reappears and begins to be animated again - the work comes to life, like a medical cardiograph or electrical pulses through a liquid, making it an interactive experience for the observer.

Optically these works are captivating and intriguing, as they mesh cognitive visual references to biological documentation with optical cues and geometry. They are also escapist and meditative, instilling a sense of calm interest within the viewer.

3.3. Translucency and Abstraction

Now I will turn from the geometric, figurative and semi-representational in glass towards a much more intuitive and abstract way of forming a spatial reference.

The work of Karlyn Sutherland examines the emotional power of place, using fused glass to create installations and wall pieces. This autobiographical work addresses significant moments and associations in memory, in addition to discussing the architectural and atmospheric aspects of space. Sutherland's research, carried out whilst undertaking a PhD in architecture at Edinburgh University, looked into the bond between people and places explored in the installation work she produced in 2016 at Latheron House, Caithness. (Figure 68)

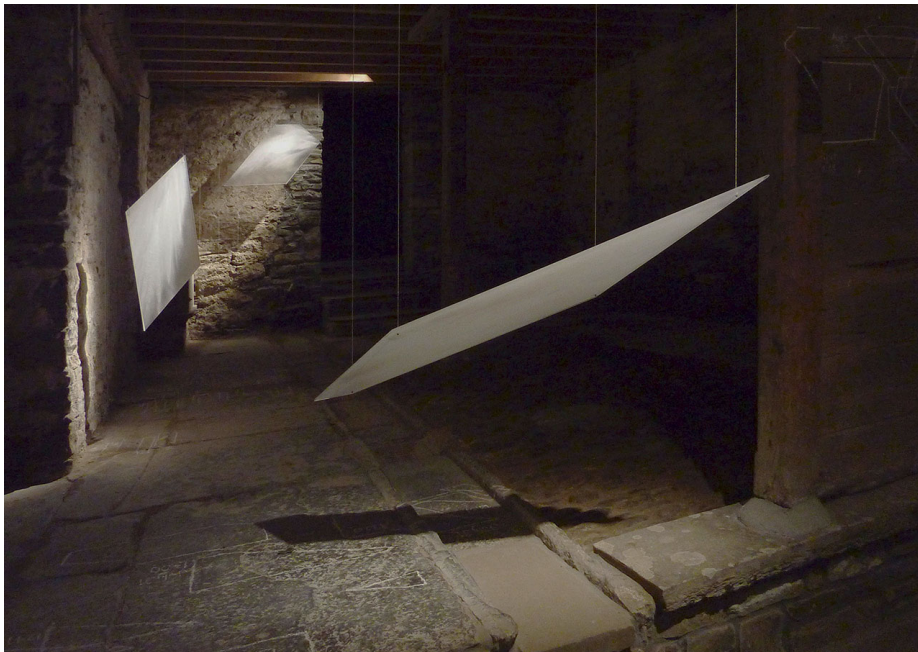

Figure 68.
Karlyn Sutherland *Latheron House, Caithness* (2016)
(Overall view of installation), fused and cold-worked glass. Dimensions variable
By kind permission of the artist

When discussing this work Sutherland explains:

Glass is an evocative material, able to readily convey atmosphere, emotion, and narrative. It has the ability to reveal memories, generate associations, and encourage the imagination in ways that other mediums often cannot. The haptic, hands-on act of making is contemplative - a tool which allows me to

explore and strengthen my own relationship with (and understanding of) place.⁷⁶

This work is site specific and takes as a starting point a description of the spatial qualities of its surroundings, at the same time as adding a ghostly animation and play of light to the environment. These suspended glass planes pass seamlessly through space and guide the viewer towards the light, much as a traditional stained-glass window did. The translucent surface quality of the glass, in places a solid white opaque and in others a more diffused semi-transparent, creates a visual puzzle for the eyes and brain regarding where in space these surfaces sit. The event of light passing through a frosted clear area pushes the glass pane backwards and allows the white opaque surface, and transitions from there, to sit in the foreground. The varying translucent quality of these pieces, created by fusing opaque white powdered glass onto sheet glass, gives the work an ethereal quality. They are a solid material but as light hits the surfaces the sense of mass fades and undulates, allowing the glass pieces to float and twist within the space. The planes of glass plot light and hold it, tracking and creating shadows in a dance towards the light. The fluctuating translucency of the glass intensifies the viewer's experience of light in relation to the space, evoking an uplifting spirituality and an emotive response.

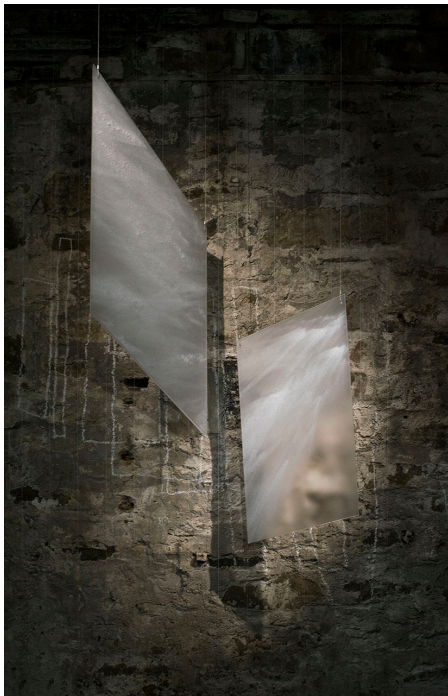

Figure 69.
Karlyn Sutherland *Latheron House, Caithness* (2016) (Detail)
Fused and cold-worked glass. Dimensions variable
By kind permission of the artist

⁷⁶ 'Artist Karlyn Sutherland', *Bullseye Projects*, <https://www.bullseyeprojects.com/artists/419-karlyn-sutherland/overview/> [accessed 15/10/17]

Exploring the Optical Perception of Image Within Glass

Jessica Loughlin is another glass artist who, like Sutherland, explores and exploits the translucent qualities of the medium. Her work also has a delicacy and sophistication of mark that enables her to communicate spatial references.

Loughlin's work explores her interest in landscape, and in particular the point within this where references to reality, object and scale disappear and space is not defined by the cognitive recognition of a form. At these points space appears infinite, calm and meditative.

Using the Australian landscape as inspiration, Loughlin adopts an abstract, minimalist approach to her depictions. These compositions, referencing specific places that are personal to Loughlin, appear beautifully simple but are technically challenging to create. It is always difficult to intentionally create harmony and simplicity. (Figure 70).

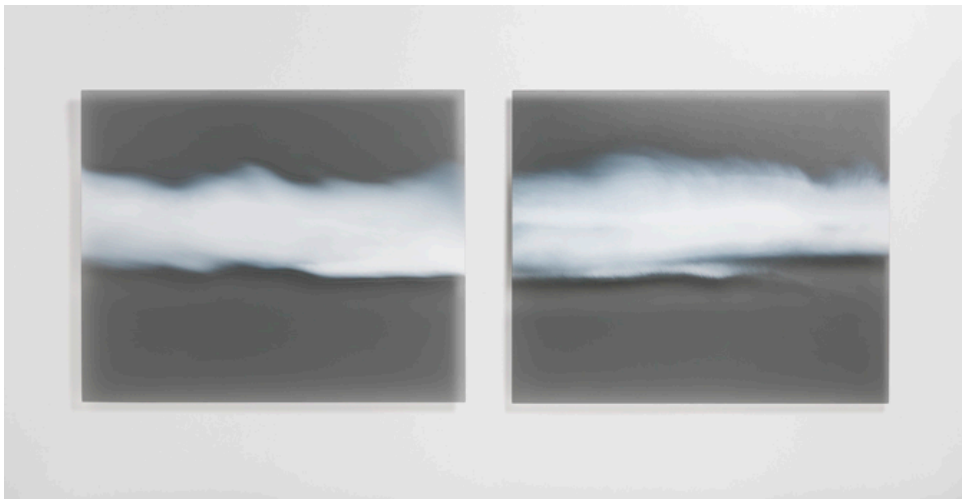

Figure 70.
Jessica Loughlin *Unfolding Continuum* (2012)
Kiln formed glass, 84 x 103 x 4cm
By kind permission of the artist

In these pieces Loughlin works meticulously, adding powdered glass, cold finishing and layering the surface of the glass sheet via multiple firings until she is satisfied with the resulting surface. The landscapes that she references are salt lakes and great expanses within South Australia, and it is there that, as a lone individual, she draws upon the sensation of being unable to gain a visual anchor. Here the horizon runs off into infinity and haze: hitting the ground creates an almost mirage effect. Our normal visual cues for scale and distance are not apparent, and the perception of space and time becomes no longer moored in reality.

As Ptolemy⁷⁷ suggests, this leaves the observer in what can be considered a no-man's land in imagining what is ahead.

The sense of sight discerns the difference of shapes, wherever they are [...] without delay or interruption, employing careful calculations with almost incredible skill, yet acting unnoticed because of its speed [...] When the sense cannot see the object through its own mode of action, it recognizes it through the manifestation of other differences, sometimes perceiving truly and sometimes imagining incorrectly [...] ⁷⁸

In addition, Gombrich notes

Unless we know the conventions, we have no means of guessing which aspect is presented to us. Even the famous glass models of flowers in the Harvard University museum would not tell a visitor from Mars very much about plants if he had never touched any. There is nothing paradoxical about this assertion. A picture of an unknown animal, or an unknown building, will tell us nothing of its size, for instance, unless some familiar object allows us to estimate the scale. ⁷⁹

Loughlin's wall pieces exploit both the translucency and opaque uniqueness of glass. Set just away from the wall, the imagery, due to the soft working of the surface of the glass, holds the light, adding further depth and tonality within these cloud-like apparitions. Here the artist also utilises the shadows, created by the semi-permeability of the glass, to add further ambiguity and breadth. The surface of the glass is indefinite and changeable as light moves over the face and new shadows form. White animated floating clouds or haze drift across, apparently constantly moving as the light changes.

⁷⁷ Claudius Ptolemy, (born c. 100 CE–died c. 170 CE), an Egyptian astronomer, mathematician, and geographer of Greek descent. In several fields his writings represent the culminating achievement of Greco-Roman science, particularly his geocentric (Earth-centred) model of the universe now known as the Ptolemaic system. ('Ptolemy', *Encyclopedia Britannica*, <https://www.britannica.com/biography/Ptolemy> [Accessed 06/12/19])

⁷⁸ Ernst Hans J. Gombrich, *Art & Illusion, A Study in the Psychology of Pictorial Representation*, Sixth edition, (London: Phaidon Press Ltd, 2002). p204

⁷⁹ *Ibid.* pp.204-205.

Exploring the Optical Perception of Image Within Glass

These compositions now become meditative, as the subtle colour and surface changes, orchestrated by light to create a graceful contemplative tranquillity for the viewer.

Loughlin's fascination with space and light is clear in her work *Receptor of Light*, Opera Unica, Adelaide, 2016. (Figure 71). This freestanding piece is created using a semi-translucent white opal glass which diffuses light. It also has the ability to change its perceived colour, projecting blue when reflecting light and warm pink to orange when transmitting light.

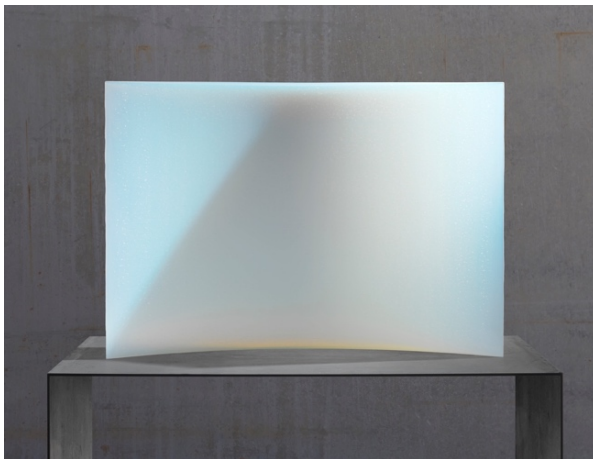

Figure 71.
Jessica Loughlin *Receptor of Light* Opera Unica, Adelaide (2016)
Kiln formed and cold-worked glass. 46 x 57 x 9cm
By kind permission of the artist



As Loughlin states in an interview for Venice Glass Week in 2017, 'My material is both glass and light. I use the glass to sculpt light and shadow.'⁸⁰

This work has an elegance and an impermanent depth and beauty that could only be realised by using this type of Opaline glass which strikes⁸¹ during the firing. This chemical process initiates a range of visual effects, from translucency to dense opacity, whilst also generating transitional effects based on light transmission, absorption and reflection. The ethereal depth of this work, I feel, recalls Mark Rothko's (1903-1970) abstract paintings in creating a sense of space and place and instilling a spiritual, emotive quality in the viewer. When first viewing Rothko's paintings at Tate Modern in London, I was struck by the depth created on this flat canvas. There was a loss of surface when gazing into the image, and a disorientating lack of recognised surface depth within the work. The paintings seemed to consist of multiple layers, none of which seemed concrete or tangible within the pictorial plane.

Loughlin's work explores the notion and perception of horizontal horizons. The viewer loses the frontal surface of the glass, as it melts away into the distance. In this work the spectator is drawn into the created space. The calm and meditative state that the limited palette and subtle colour transitions evoke bring an intimacy to the work, a communication with the viewer, which counteracts the abstract absence within the casting and captivates the observer.

3.4. Geometric Perspective

Interestingly, both Sarmiento and Sutherland have also created works that apply the geometric rules of perspective. Here, in works that differ from the pieces discussed earlier, we are presented with recognisable substantial forms that play on our understanding of mathematical perspective theory and flatten our perception of three dimensions. (See Figure 72).

⁸⁰ Contessanally, 'The Venice Glass Week: Caterina Tognon Gallery, Jessica Loughlin', September 2017, <http://contessanally.blogspot.com/2017/09/the-venice-glass-week-caterina-tognon.html> [Accessed 15/8/18]

⁸¹ Glass that changes colour when re-heated is said to 'strike'. The most dramatic example of this are ... colours in the ruby family that strike from a clear to deep red simply upon reheating. ('Glossary of Terms', Northstar Glass, <http://northstarglass.com/users-manual/glossary-terms/>. [Accessed 19/04/18])



Figure 72.
Jeffery Sarmiento *Estate* (2012)
Waterjet cut, printed, fused and polished glass. 140 x 63 x 4cm
By kind permission of the artist

Sarmiento, in this piece from his series *Buildings*, combines inspirations from the social history of the North-East of England with the notion of the urban. Initially the geometry and mass within these dark and solid glass wall pieces alludes to a sinister and looming monumental scale. The sections are placed just off the wall, allowing the shadows created to evoke a third dimension of depth and form. These are CAD-designed and waterjet-cut black glass frames which have a precise, machined feel, suggesting emotions of coldness and containment.

The architectural reference to space is obvious here, but it is only when you look more closely that the necessity to create this work in glass, as opposed to wood, is apparent. (Figure 73).



Figure 73.
Jeffery Sarmiento *Estate* (Detail).(2012)
Waterjet cut, printed, fused and polished glass. 140 x 63 x 4 cm
By kind permission of the artist

On closer inspection, Sarmiento has added a personal association to this work by depicting, within the architectural form, portraits of sixty people from the local area, creating a work that echoes the human urban experience. The layering and careful positioning of these portraits within the glass, at an angle, allows the viewer to only see the individual's faces from a certain vantage point. This viewing angle optically suggests a depth greater than that of the black glass casing and opens up a discourse around notions of hidden societies and the isolation associated with this type of brutalist social housing. With this humanistic metaphor Sarmiento begins to construct a contemporary depiction of this urban edifice.



Figure 74.
Jeffery Sarmiento *Centre* (2012)
Waterjet cut, printed, fused and polished glass. 200 x 104 x 5cm
By kind permission of the artist

Exploring the Optical Perception of Image Within Glass

In Sarmiento's work *Centre* (Figure 74), also produced in 2012, he attempts to convey this further, presenting a façade based on the principles of London high-rise flats from the 1960s and 70s.

The use of exaggerated three-point perspective makes this already large work appear to tower over the viewer.

With both of these pieces Sarmiento employs the identifiable visual vehicle of perspective but chooses to graphically abstract this to a simplified but readable form. The viewer is instantly able to reference the shape as architectural and, on further inspection, comprehends the human societal overtones related to the work.

As mentioned earlier, Karlyn Sutherland has also adopted the geometric rules of perspective in her more recent works. Like Sarmiento's, these works have a precise digital approach, which can be seen as visually juxtaposed to the installation piece discussed above. This work, still interested in the qualification and realisation of a given space, has become wall based. Rather than impacting on the space, using a visually translucent or opaque language, this work, like [Grootens'](#) painted forms, creates a clearly defined notion of contained space. It discusses a pure graphical perception of an enclosed space embedded within contemporary digital language. Interestingly this work, like Sarmiento's, also talks about a place: '*Scrabster, Caithness* (2)'. (Figure 75).

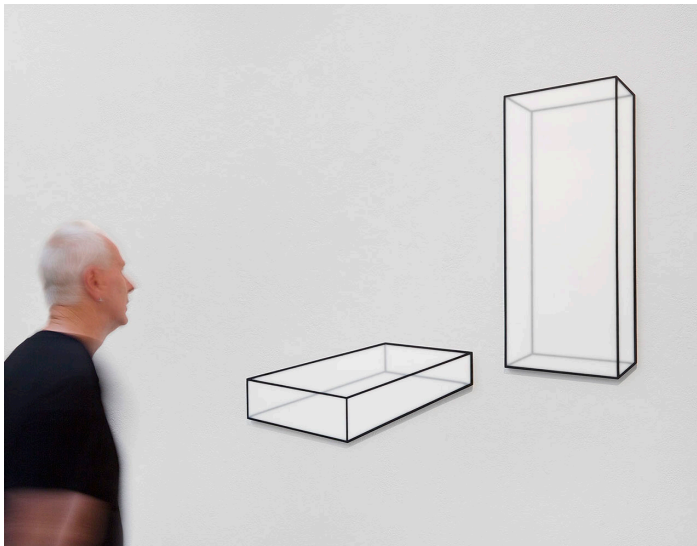

Figure 75.
Karlyn Sutherland *Scrabster, Caithness* (2) (2017)
Fused sheet glass. 89 x 103 x 0.6cm
By kind permission of the artist

Here, the abstraction of a place into rectangular boxed units that simply mathematically quantify the space, and it is the weight of linear tone which starts to convey a spatial reference. Shadows, created by setting the works slightly away from

the wall, now add an additional sense of depth, giving an optical illusion of floating forms. The conventions of perspective are played out in this work: optically we understand this language and what it attempts to portray. It is a familiar vehicle which we acknowledge as a two-dimensional rendering to create the illusion of three dimensions. But now the shadows, which the works generate, form part of an ocular ambiguity, as the familiar language of two dimensions gains depth.

This diagrammatical, arithmetical language, which lacks gradation and lends itself to digitally created imagery, is clinical. One can only think that the rationalisation of this place into precise geometric forms is a metaphor for the stripping of personal associations from the community associated with these spaces, whether stereotypical or perceived. Given Sutherland's previous work and her background within architectural design, one assumes that these graphic illustrations have been fabricated to ask the reader to question the associations borne by the title.

These glass works are recognisable, logical, calm and precise. They offer the viewer a Zen-like space to get lost within, again drawing you in, the comfortable and familiar forms perhaps seducing the viewer with their simplicity. Or is it that the minimal existence of these almost architectural drawings, with no fussy façade details or motifs, pare down the human content of these spaces to simple spatial ratios?

3.5. Between Two and Three Dimensions

Three-dimensional artworks that are attached in some way to a flat wall are said to be in relief or a relief element. The next works I discuss belong to this artistic category, neither totally two dimensional nor totally three dimensional.

Reinoud Oudshoorn works in a range of materials, including glass, creating sculptural spatial illusions. These works consider the perspective of the viewer, working in tandem with the psychology of the [Gestalt principles](#) discussed in the previous chapter. That is, depending on the viewing position of the observer, these works can be perceived in an infinite number of ways, as the visual solutions are provided by cognitive and optical assumptions.

Oudshoorn unpicks our understanding of how space and the rules of optical perspective work. In a similar way to the works of [Jane Harris](#) and [Ester Stocker](#), mentioned earlier in the thesis, these sculptural forms challenge our optical understanding of the spatial reference before us and create an unstable 'in between' that intrigues.

Oudshoorn's piece *B-10* (Figure 76) is a wall-mounted work in glass and metal composed of three overlapping circles in space. The combination of these forms

creates an optical illusion of shapes in perspective. It uses the Gestalt overlapping principle visually, enabling the viewer to set the circles in order and in receding space.



Figure 76.
Reinoud Oudshoorn *B-10* (2010)
Iron and frosted glass. 70 x 70 x 7cm
By kind permission of the artist

But here the frosted glass circle at the front, edged with iron, appears to reduce the size of the underlapping portion of the circle behind. This plays with our understanding of overlap, perspective, transparency, opacity and linear forms. At first the viewer believes that they understand what is happening within the work, but the semi-transparent frosted glass, with the disproportionately smaller section of the solid black circle behind, creates the sense of even further depth. Due to our understanding that objects get smaller as they recede into space, we start to question where the edge of this circle sits. This optically jarring, destabilising element alludes to a circle which is much further back and could even be embedded in the wall. The diffused softness of this receding circular edge created by the frosted glass also suggests images of shadow and eclipse, perhaps a planetary orbit or telescopic misfire.

This same suggestion of space, in this case using a softened linear pattern, is evident in the piece entitled *B-11*. (Figure 77)

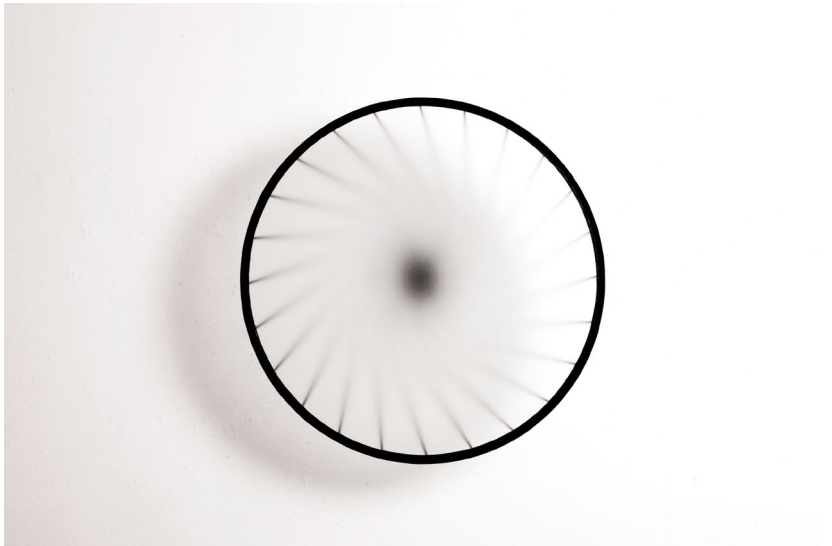

Figure 77.
Reinoud Oudshoorn *B-11* (2011)
Iron and frosted glass. 70 x 70 x 13cm
By kind permission of the artist

Again, the frosted glass surface is exploited to create such an extreme softness of focus in the work that the lines, which initially are seen clearly, start to disappear into a blurred black hole. Once again we are intrigued by the depth this creates, as the lines become more and more out of focus until they disappear into a misty depth. For the observer this generates a spatial quandary, as the brain and eye are unable to locate this black hole in a spatial reference.

Interestingly, optically this attempts to mimic how we as humans initially focus in on an area of an object or plane whilst all peripheral visual information is out of focus. As our eyes instinctively flit around an image, object or space, gathering information, the process of accommodation allows the eye's focus to adjust as objects come forward and recede. During this reflex action of the eye, the lens is adjusted in shape and curvature to allow images to focus onto our retina from near and distant points.

In reality we are unaware of this process, as it happens at speed and we recall the object or space as a whole image.

As we have seen, the artist's decision to soften or blur areas of an image is widely exploited. This intentional manipulation of focus is a technique used particularly in the field of photography, where it is known as Bokeh.

Bokeh, also known as 'boke', is one of the most commonly employed techniques in photography. The reason for this is that bokeh makes photographs visually

appealing, forcing us to focus our attention on a particular area of the image. The term comes from the Japanese word for 'blur'.⁸²

In this technique, blur, or bokeh, is used to exaggerate depth or draw the viewer to a particular focus: see Anna Gay's *Abstract-art-blur*, 2011 (Figure 78). When painting or drawing an image, artists are able to render everything sharply, with clarity. As mentioned, our eyes almost instantaneously find a focus while they dart across a scene: by focusing on several areas to construct a realistic image of the space or object as a whole. In photography it is rarely possible to focus crisply on everything within a shot and it is this blurring that distinguishes photography from human vision.



Figure 78.
Anna Gay *Abstract-art-blur* (2011)
Photograph. (dimensions not provided)
By kind permission of the artist

⁸² Nasim Mansurov, 'What is Bokeh and How it Affects Your Images', *Photography Life* (11 July 2019), <https://photographylife.com/what-is-bokeh>, [Accessed 05/08/19].



Figure 79.
Reinoud Oudshoorn *B-14* (2014)
Frosted glass and iron. 72 x 66 x 21 cm
By kind permission of the artist

In *B-14* (Figure 79) Oudshoorn is using what is termed in photography 'transitional bokeh'. This technique involves controlling the transition of crisp sharp photographic areas to areas that are out of focus. This is an exaggeration of what happens optically if we were able to capture the gathered image from just one of our eyes as it instantaneously flicks across a view gathering data. This captures a sharp focus on the area of interest and then the gradual blurring as peripheral vision tails off.

Although derived and constructed using Western mathematical principles, these works, through their materials, surface and physicality, are overtly contemplative, captivating and illusionary. Exuding a sense of calm, Oudshoorn's pieces create what is perceived as a mysterious depth, which is incomprehensible for the viewer.

In the catalogue for Oudshoorn's 2012 solo exhibition 'Dimensions', Wonseok Koh states:

This is an action that deletes any prior prejudice upon every subject and contemplates the surface itself. At the same time, it is a process of meditation to establish an order that exists beyond its surface. Therefore, it could be considered as very eastern. As the rules of perspective that led the age of Renaissance in west were derived from the artistic will to defeat the limits of two dimensions, all the processes of making complicated calculations and drawings, choosing materials and producing the art works structure

Oudshoorn's artistic actions in order to create three dimensional space within the limited surface.⁸³

These works are restrained and work within a limited space, curated and controlled by the surface physically and the outer boundaries of each form. That said, to the viewer they offer a contemplative perceived depth far beyond that of the physical world.

As Reinoud Oudshoorn has commented when talking about his artistic approach, he feels that [...] 'Sculpture should create a bigger space than its occupied space.'

Another sculptor who works with glass to create illusions exploring light and visual perception is Olafur Eliasson. This Copenhagen-born artist grew up in both Iceland and Denmark and his work reflects his connection with spatial environments and the natural world.

Eliasson relies on the interaction of the observer in order to generate the desired emotive and aesthetic experience of the work. This work, titled *The Listening Dimension (orbit 1, orbit 2, orbit 3)*, 2017 (Figure 80), was installed at the Tanya Bonakdar Gallery for Eliasson's first solo show in New York since 2012.



Figure 80.
Olafur Eliasson *Orbit 2* (2017)
Stainless steel, brass, paint (black), mirror foil, aluminium. 280 x 712 x 315cm
By kind permission of the artist

On entering the installation, this expansive work, incorporating vast mirrors and metal, makes the viewer instantly start to question what they are seeing. Large rings appear to hover in the room, seemingly unattached, whilst repeated virtual ring

⁸³ Wonseok Koh, 'Dimensions', Reinoud Oudshoorn, [exh.cat] (Korea: Arko Art Centre, 2012).

Exploring the Optical Perception of Image Within Glass

forms echo through what is perceived to be infinite space, only differentiated by colour; some black, some brass. It appears that the reader is initially totally immersed within an unreality. We rely implicitly on our understanding of our world; the psychology of the Gestalt principles convinces us of what we think we are seeing. Notions of closure, proximity and continuity complete our visual picture, assuming that all is as it first appears. But here perceptual references quickly disappear out of reach and, like [Loughlin](#)'s mirage-like horizons, the viewer has no point of anchor. That is until they start to move within the space. This tentative action then starts to activate disclosures on how the space operates and where within it you are located. (Figure 81)



Figure 81.
Olafur Eliasson *Orbit 2* (2017)
Stainless steel, brass, paint (black), mirror foil, aluminium. 280 x 712 x 315cm
By kind permission of the artist

First, the observer becomes part of the work, reflected repeatedly within the mirrors. Eliasson has constructed a large-scale infinity mirror within this space. This effect works on the principle that when two mirrors are placed parallel to one another the light waves caught between them bounce repeatedly off the two surfaces, backwards and forwards. The reflections captured by each mirror are then bounced off one mirror and onto the opposite, creating a series of smaller reflections which recede into an infinite distance.

This immersive visual reference triggers a more intent questioning of the optical data, as the brain tries to comprehend the unstable space it is in. Through closer scrutiny, the poetic reflective action of the mirror yields its secret connection with the metal rings and the viewer gains a realisation that these are half rings or semi-circular tubes of metal, which appear whole through their reflection in the mirrored surface.

The huge seven-metre-long mirrors do not totally cover the gallery walls: this allows human cognition to recognise the room's edge and beyond that edge are the familiar architectural structures that form a white-walled room. This illusion is not seamless, nor is it meant to be, but it does create convincing optical paradoxes for the brain, a confused spatial orientation. This constructs a dialogue which transverses our visual assumptions of what actual space is and what reflected space is. Here, as in [Oudshoorn's work](#), we are asked to interrogate our own perception and encouraged to reflect on how we look at and question things.

Interestingly, when talking about this work Eliasson stated that:

The listening dimension emerged against the backdrop of the 2016 US elections. At a time when oversimplification is everywhere, I believe that art can play an important role in creating aesthetic experiences that are both open and complex. Today, in politics, we are bombarded with emotional appeals, often linked to simplistic, polarizing, populist ideas. The arts and culture, on the other hand, provide spaces in which people can disagree and still be together, where they can share individual and collective experiences that are ambiguous and negotiable. At its best, art is an exercise in democracy; it trains our critical capacities for perceiving and interpreting the world. Yet art does not tell us what to do or how to feel but rather empowers us to find out for ourselves.⁸⁴

Eliasson's work *Your Trust*, 2014, (Figure 82) also appears to address our ability to interpret or believe in what we are seeing by employing the combinations of light, form and colour to confuse and intrigue.

⁸⁴ Olafur Eliasson, quoted in a press release by The Tanya Bonakdar Gallery, *Artsy.net* (March 2017) <https://www.artsy.net/show/tanya-bonakdar-gallery-olafur-eliasson-the-listening-dimension> [Accessed 15/08/18]



Figure 82.
Olafur Eliasson *Your Trust* (2014)
Coloured glass (green, light blue, blue, pink, orange, yellow), stainless steel, paint
(anthracite). 190 x 60 x 60cm
By kind permission of the artist

In this work, six sheets of colour-tinted glass, with differing elliptical cut sections, are stacked one in front of the other. Notably, this assemblage is displayed at eye level, constructing a head-on viewpoint which ensures that the six glass elements are not viewed individually but as one, each impacting on the other as filters to the next. Again, this work requires the observer's interaction, which allows the shapes and colours to move and emerge. Viewed almost holographically these transitioning perspectival ellipses intriguingly blend and fade from warm to cold, full circle to shallow ellipse. The reader's curiosity, on approaching the piece, facilitates the need for movement, to see into the box, to understand what colour each glass sheet is and analyse how these semi-animated forms are generated. Closure and interposition cues trigger a spatial confusion. Where do these familiar graphic forms sit? Which one is at the front and which is at the back?

The shapes seemingly document the movement of the same disc form, from upright to flat in a gradual sequence, perhaps familiar in their reference to sunrise or sunset. Colour also impacts on the spatial ambiguity: warm colours are perceived as coming forward whilst cool colours recede.

As the title suggests, the piece questions the trust we have in what we assume we are seeing and the complexity of the components that engineer this illusion, each impacting on the next to create an invented whole.



Figure 83.
Olafur Eliasson *Your Fading Self (West)* (2013)
Partially silvered glass, wood, concrete, rubber. 221.8 x 119.5 x 36.5cm
By kind permission of the artist

Finally, in Eliasson's work *Your Fading Self (West)*, 2013 (Figure 83), the observer, on entering the gallery, has their view into the space thwarted by a black darkness, fading from solid black to transparent, from one edge of a large sheet of glass placed upright within a wood and concrete block. On entering the space and then turning back to comprehend the obstruction, the observer finds a corresponding mirrored finish. This also fades to transparency but now the reflection afforded by the mirrored surface, in combination with reality viewed through the glass, creates a spatial juxtaposition. Made up of tiny pixels of mirrored finish, the graduation of reflection to reality confuses and captivates, inviting the viewer once again to investigate in order to make sense of what they are seeing. Again, our visual understanding of the space has been disturbed, destabilised: we mistrust it. And as the reader moves, they too appear to gradually fade as reality takes charge.

Finally, I mention here the work of Larry Bell. Creating works which predominantly explore light on surface, since 1959 Bell has examined spatial ambiguity and visual perception. Principally employing glass as a facilitator, with a myriad of surface treatments and finishes, these spatial installations question our visual understanding of space and our environment. Cubes have been an ongoing interest for Bell in his exploration of volume and mass, in addition to challenging the conventions of seeing. I had the experience of viewing one of these works in Venice, at the exhibition 'Furnace in Marseille. Cirva'. The piece on display, *First & Last*, 2018 (Figure 84), deployed the formal structure of a cube, giving it mass and organised volume.



Figure 84.
Larry Bell *First & Last*, installation view (1989)
Variable dimensions: from 183 x 244 x 244cm to 183 x 548 x 732cm.
Photography by Helen Slater Stokes

But this semi-transparent blue/grey form paradoxically altered on examination, as triangular internal and external forms appeared to transition between solid existence, with a physical mass, to ghostly echoes on the reflective surface of the glass. Here again, as in Eliasson's work [Orbit 2](#), the observer is left questioning the reality of this constructed space. On entering the cube, the perception of both the interactor and the onlooker changes, as these viewers determine an unstable construct of what they are perceiving, as wall and human forms fade in and out of being. Reflection obscures transparency, as in [Your Fading Self](#) (west), and the onlooker peering in is met with their own reflection. Interaction with the work changes the formal reference again, as figures within the work appear and transition back towards the reflected self. Our perception of mass, structure and reality are all questioned in this work.

As has been documented in this chapter, glass as a material not only offers a transparent window on the image but is able to circumvent our perceived understanding of the image and our spatial constructs. Surface treatments which diffuse light, or add reflection, create miscomprehensions whilst lenses and colour magnify and exploit our reading of spatial reference.

This led me to consider what glass, with its capability to exercise all these visual contradictions, could bring to a multi-dimensional image.

4. Technological Development of the Image

4.1. History of Multi-dimensional Imagery

Having proposed this research based on the links it has to the current development of 3D and multi-dimensional imagery within film and television, it was necessary to research into the historic development of this contemporary technology in order to create a context, whilst also uncovering possible physical solutions to the technical problems involved.

Throughout history, humans have attempted to define and record the world around them. Even as early as 280 A.D, it is believed that Greek mathematician Euclid (mid-4th century to mid-3rd century BC), had begun to understand how we make sense of the 3D world around us. Some scientists now believe he was able to describe depth perception as our ability to receive the simultaneous impression of two disparate images of the same object by means of each eye. However, it should be noted that many researchers have dismissed this suggestion as factually incorrect.

The theory Euclid adhered to seems to follow from a number of phrases. In one postulate he says, 'those things upon which the vision falls are seen'. And the first theorem states: 'nothing is seen at once in its entirety' and he explains that his rays of vision diverge and are not contiguous, but '(the object) seems to be seen all at once because the rays of vision shift rapidly'.⁸⁵

Interestingly, at this time Euclid writes as though rays are emitted from the eyes, which is understandable when we consider that Plato (c. 428–347 BC) had earlier advocated that rays from the eyes mixed 'with luminous rays from the sun (or other sources) and gave the visual sensation.'⁸⁶

From the 14th to the 16th century, European Renaissance artists brought the notion of perspective into their work. But artist Giovanni Battista della Porta (1538–1615) expanded upon Euclid's unresolved assumptions regarding binocular vision and developed stereoscopic drawings. Della Porta devised the technique of drawing two

⁸⁵ Michael Lahanas, 'Ancient Greek Optics', *Hellenica World*, <http://www.hellenicaworld.com/Greece/Science/en/Optics.html> [accessed 21/05/15]

⁸⁶ Ibid.

precise images of an object, each of which was observed from a different viewpoint.⁸⁷

Sadly, none of these drawings survive, but the interest in multi-dimensional effects grew. In 1692, French Painter Gaspar Antoine de Bois-Clair developed a technique using a grid of vertical laths, between the viewer and the painting, that allowed the observer to see two different images depending upon which side they viewed the painting from. (See Figure 85)



Figure 85.
Gaspar Antoine de Bois-Clair Double Portrait of King Frederick IV and Queen Louise of Mecklenburg-Güstow of Denmark (c. 1654)
39.4 x 32.4cm

At this stage multi-dimensional effects were being created based on one finding, that fundamentally we are able to see in three dimensions because we have two eyes. With each eye seeing the world from slightly different viewpoints our brain is able to combine the information from both eyes in order to work out the distance of an object from us, or the depth of field.

Although evidence of this knowledge seemed to be readily available, it was not until the 1830s that Charles Wheatstone became the first to describe a mechanism to display 'stereoscopic imagery'⁸⁸, (Figure 86)

⁸⁷ Barry Blundell, *An Introduction to Computer Graphic and Creative 3-D Environments* (London: Springer-Verlag, 2008)

⁸⁸ Stereoscopic Imaging is a technique used for creating or enhancing the illusion that an image has depth by showing two slightly offset images separately to each eye of the viewer. ('Stereoscopic Imaging', Techopedia, <https://www.techopedia.com/definition/91/stereoscopic-imaging> [Accessed 19/12/17])

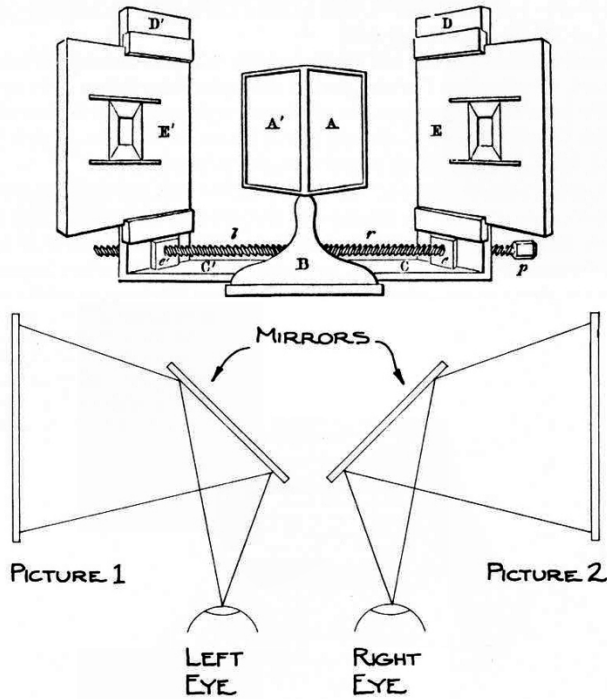

Figure 86.
Diagram of Charles Wheatstone's Stereoscope (1838)

At this point the initial imagery used was drawings, as these designs preceded both photography and film. But with the development of the daguerreotype in 1839, invented by Louis-Jacques-Mandé Daguerre, the new photographic medium enabled the creation of permanent images with a camera, and the depictions became more complex. Unfortunately, this led to its own complications as the daguerreotype proved difficult to light evenly, and due to long exposure times was very difficult to accurately match up to give a clear 3D effect. (See examples in Figure 87).



Figure 87.
Louis J. M. Daguerre
Daguerreotype – original version and as restored (c 1840)

New developments in photography meant that the methodology of multi-dimensional imagery split into three separate strands. The first was those working with the notion of two independent, dissimilar images to create the illusion of depth; second those working with the barrier method (using a barrier in front of the image to separate and hide sections) and the third those attempting to integrate the image and viewing mechanism together. These three strands are discussed in the following sections

4.2. Strand One - Stereoscopic - Two Dissimilar Images

The British physicist and inventor David Brewster took Wheatstone's stereoscope viewer, as mentioned above, and improved the effect by using prisms instead of mirrors. This made the viewer smaller and more convenient to use, as the details of images could be positioned directly to each eye. (Figure 88)



Figure 88.
Examples of Sir David Brewster's Stereoscopes (1849)

Oliver Wendell Holmes developed this further by adding convex lenses as eyepieces for the prisms, and as photographic technology developed, 'stereo' photographs were taken with stereo cameras, and these devices became popular parlour and amusement arcade entertainment. (Figure 89)



Figure 89.
Example of an Oliver Wendell Homes-type, Stereoscopic Viewer (c. 1905)

After the introduction of the commercial hand-held stereoscopic viewer in the 1950s, 'scenes from around the world, as well as images from movie studios, such as Walt Disney Studios, were brought into homes as "stereoscope images"'.⁸⁹

The late 1950s saw advances of this nature within the film industry, and the popular technology known as, 'anaglyph'⁹⁰ produced polarized spectacles for the viewer that enabled the creation of multi-dimensional films, such as *Creature from The Black Lagoon* in 3D (1954). (Figure 90). These glasses proved extremely popular, and cartoon books included specially printed artworks using this technology, creating a video-like experience for the viewer.



Figure 90.
3D Film Footage Still (1954) The Creature from the Black Lagoon in 3D

⁸⁹ Dr R. Barry. Johnson, Gary A. Jacobsen, *Advances in Lenticular Arrays for Visual Display*, 25th August 2005, <https://www.spiedigitallibrary.org/conference-proceedings-of-spie/5874/587406/Advances-in-lenticular-lens-arrays-for-visual-display/10.1117/12.618082.short> [Accessed 20/10/15] pp2

⁹⁰ Anaglyph is a type of stereo 3D image created from two photographs taken approximately 2.5 inches apart, the distance typically between human eyes. The red colour field of the left photo is combined with that of the right photo in such a way as to create the illusion of depth. In America, usually the RED, BLUE lens glasses are worn to view the effect, in Europe the RED, GREEN combination is common (Fred Wilder, 'Anaglyph 3D Know How, *Fred Wilder Studios*, <http://stcroixstudios.com/wilder/anaglyph/whatsanaglyph.html>)

4.3. Strand Two - Parallax Barrier Methods

At this stage, photographic developments began to take place in tandem with the advances in viewing mechanisms, and the development of these photographic techniques became paramount.

The barrier technique, used in a basic form by Bois-Clair, as seen above (Figure 85), was developed using photographic methods by both John Jacobson and Auguste Berthier, independently, around 1896, and was finally applied fully by Frederick E. Ives (1856-1937), an American scientist, in 1903. Called the 'parallax stereogram' by Ives, it was essentially a stereo viewing aid placed on the picture instead of the eyes.⁹¹ (Figure 91)

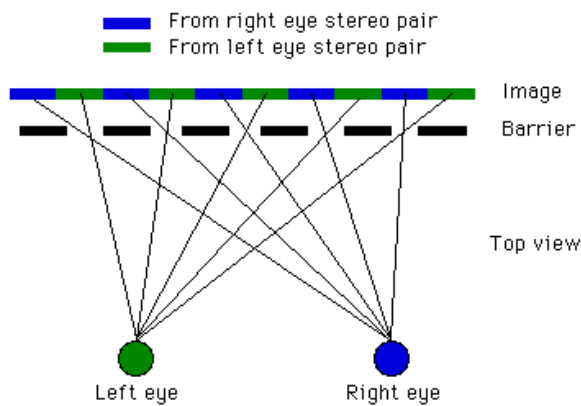
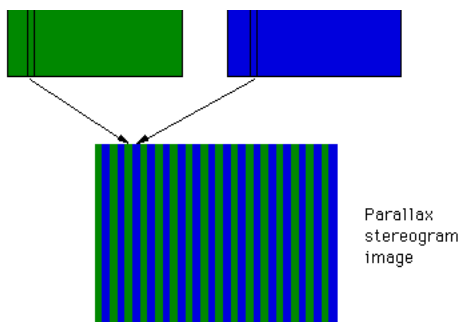

Figure 91.
Paul Bourke Autostereoscopic Lenticular Images (1999)



The parallax stereogram system involved a barrier screen which 'consisted of vertical opaque lines, separated by clear slits of lesser width. A transparent glass plate behind the barrier screen which created spacing between it and the photographic emulsion that consisted of the picture information divided into fine mosaic image stripes aligned behind each clear aperture.'⁹² It created images from both left and

⁹¹David E Roberts, Lenstar Lenticular: History of Lenticular, <https://www.lenstarlenticular.com/history-of-lenticular> [Accessed 06/09/2015]

⁹² Ibid.

right eye perspectives on strips, and these were placed alternately at the same pitch as the barrier slits in the plate. This gave the viewer the two disparate views of one object needed to realise a three-dimensional impression. This development greatly informs the lenticular technology of today.

Although this barrier-based method used a parallax stereogram image for binocular viewing, it had limited effectiveness with regard to its viewing position due to the narrow slits that had to be employed. Of course, this is still true of today's lenticular postcards and pictures, with viewing angle and distance still an issue.

Incredibly, despite these issues the Soviet Motion Picture and Photography Research Institute took this approach a stage further by starting to project parallax stereogram motion pictures onto a large non-parallel-type barrier screen.⁹³ Interestingly, Russia are still the world leaders in current lenticular print technology, with closely guarded processes used to create crisp and accurate three-dimensional imagery. Despite improvements, again the viewing range was limited, as the stereo image could only be viewed from a small number of seating positions. In addition, as mentioned previously, any side-to-side movement of the head whilst viewing would result in left and right views switching, thus creating what was termed a 'pseudoscopic image'.⁹⁴ Here the image's depth of field was inverted, giving the illusion that the foreground was in the background spatially and the background at the front.

This problem of pseudoscopic zones was resolved for the most part by adding multiple views beyond the two stereo views for a wider range of viewing. This adds a 'look around' capability, where the picture moves through a sequence of stereo views as the viewer moves from side to side, revealing different aspects of an object or scene.⁹⁵

Essentially this was no longer a binary image production method, as multiple viewpoints were captured. The 'parallax stereogram' approach was developed further by American physicist Clarence W. Kanolt, in 1915, 'who proposed the first method that allowed for multiple views behind the barrier screen. Kanolt used various 'scanning' type cameras that moved horizontally in front of a subject, or in a

⁹³ David E. Roberts. *History of Lenticular and related Autostereoscopic Methods* (Hillsboro, WI: Leap Technologies, 2003),

http://archiviostereoscopicoitaliano.it/documenti/history_of_lenticular.pdf. [Accessed 10/09/15]

⁹⁴ As it pertains to aerial photography, stereo viewing in which the normal impression of relief is reversed. ('Pseudoscopic Image', *The Free Dictionary*, <https://encyclopedia2.thefreedictionary.com/pseudoscopic+image>)

⁹⁵ David E Roberts, *Lenstar Lenticular: History of Lenticular*, <https://www.lenstarlenticular.com/history-of-lenticular> [Accessed 06/09/2015]

horizontal arc around them'.⁹⁶ This allowed a wider viewing angle for audiences. This was known as the parallax panoramagram process.⁹⁷ (Figure 92).

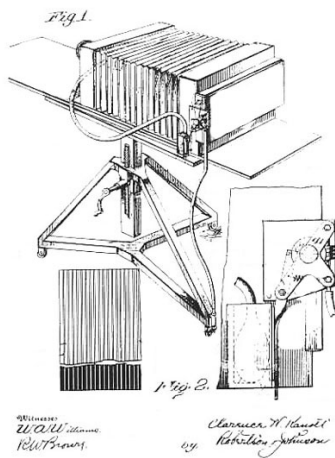

Figure 92.
Clarence W. Kanolt Parallax Panoramagram Camera (1918)

Herbert E. Ives (1882-1953), son of Fredrick E. Ives, made great advances with this 'parallax panoramagram' technique. Ives began to work with a large aperture camera lens, the diameter of which was wider than the 'interocular distance'.⁹⁸ This created continuous sets of views, and the barrier screen ensured that a clear line of image was created as the image was photographed, thus allowing a clear capture of moving subjects or group photographs. (Figure 93) Ives also refined this 'look around' process further by changing the large round lens for a small lens which was scanned from left to right in front of the barrier to create the required image.⁹⁹

⁹⁶ Walter Funk, History of Stereoscopic, (2010)

Cinema http://www.hologlyphics.com/Autostereoscopic_Cinema_History.pdf [Accessed 12/8/17]

⁹⁷ Takanori Okoshi. *Three Dimensional Imaging Techniques*. (New York: Academic Press, 1976). p17.

⁹⁸

Interocular distance the distance between the eyes, usually used in reference to the interpupillary distance (the distance between the two pupils when the visual axes are parallel). ('Interocular Distance', Medical Dictionary, *The Free Dictionary*)

<https://medical-dictionary.thefreedictionary.com/interocular+distance>

⁹⁹ David E Roberts, Lenstar Lenticular: History of Lenticular, <https://www.lenstarlenticular.com/history-of-lenticular> [Accessed 06/09/15]

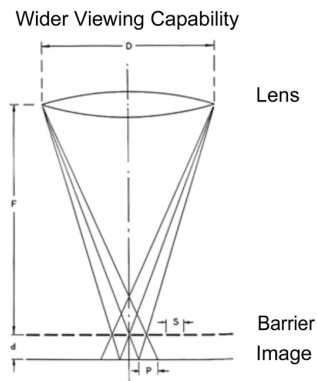

Figure 93.
Herbert Ives *Drawing of Large Lens camera Method* (1930)

This development introduced research into a range of camera systems, known as 'scanning' cameras, contemporary versions of which are used in today's film industry. Herbert Ives later went on to pioneer work in the early development of television, and 'by his retirement in 1947, Ives had published more than 200 papers, and secured more than 100 patents'.¹⁰⁰

4.4. Strand Three - Integral Images

This new strand of research began with Gabriel M. Lippmann,(1845–1921), a French optics investigator, who discovered 'integral photography'.¹⁰¹ This was a process that enabled the recording of a complete spatial image on a single flat photo plate. He did this by using a series of lenses on the surface of a picture instead of using a barrier of opaque lines, as Ives's had done. Using a series of small spherical lenses, a 'fly's-eye lens array' he was able to record and play back spatial images with parallax in all directions. (Figure 94).

¹⁰⁰ David E. Roberts, D. E. History of Lenticular and related Autostereoscopic Methods, (2003) Leap Technologies, LLC. PDF. pp4 http://archivostereoscopicoitaliano.it/documenti/history_of_lenticular.pdf [Accessed 21/11/15]

¹⁰¹ The term 'integral' comes from the integration of all the micro images into a complete three-dimensional image through the lens array. David. E. Roberts, Lens Array Print Techniques: The History of Integral Print Methods. <http://lenticulartechology.com/files/2014/02/Integral-History.pdf> [Accessed 20/10/15]

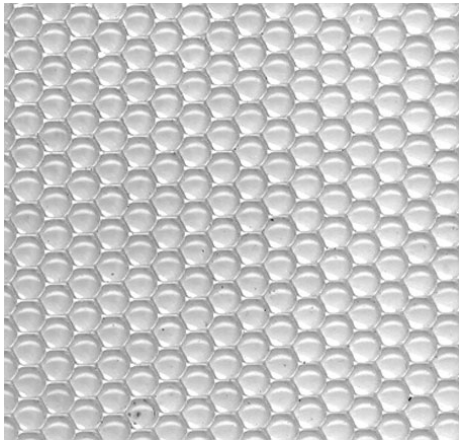

Figure 94.
An Integral *Fly's-eye* Lens Array Greatly Enlarged (2003)

Late in the 1920s scientists, including Herbert Ives, revisited Lippmann's integral image design and altered his 'fly's-eye' lens array to a linear array, known as 'lenticules'. This sheet was transparent, as was Lippmann's, with a flat back face which referenced the focal plane, but its great advantage was the links it shared with the earlier barrier screen methods, which employ strips of the image.

The 1930s saw advances in lenticular lens array, and this lens system was thrust into the commercial arena, not as a tool for 3D photography but combined with the process for producing colour films, by Kodak in 1928. Now individual strips of image referencing the red, green and blue content of a single viewpoint could be recorded and meshed through a unique projection system into a full-colour image, whilst using only black and white emulsion.¹⁰²

During the 1960s lenticular processes rapidly progressed, as commercial companies exploited the advertising potential of lenticular promotional materials such as postcards. Mass production became a reality on February 25th 1964, when an issue of *Look* magazine featured the 'first ink-printed postcard sized "parallax panoramagram"'.¹⁰³ (Figure 95) The subject of this image was a black-and-white still life of a bust of Thomas Edison surrounded by some of his best-known inventions

¹⁰² David E Roberts, Lenstar Lenticular: History of Lenticular, <https://www.lenstarlenticular.com/history-of-lenticular> [accessed 06/09/2015]

¹⁰³ Ibid.

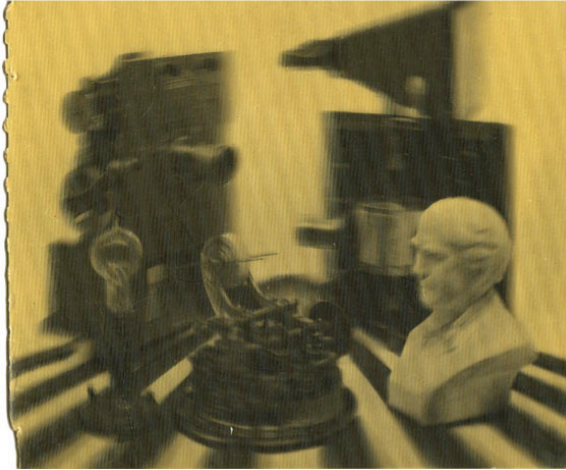

Figure 95.
Look Magazine featured Parallax Panoramagram (1964)
17.78 x 17.78cm

This feature was followed by a colour parallax panoramagram in the magazine in April 1964 (Figure 96)

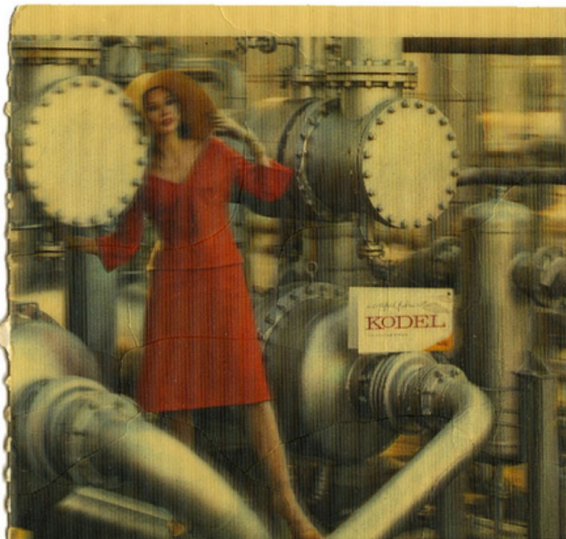

Figure 96.
Look Magazine 2nd featured Parallax Panoramagram (1964)
17.78 x 17.78cm

Research has now advanced within the field of 'integral photography' and the development of lenticular lenses with inventions like the Integram, by Lannes de Montebello (1908-1986). (Figure 97). Lannes de Montebello developed the CrystalChrome camera (Figure 98), which used a lens in front of the camera in order to capture visual depth. Prompted by advances in the digital interlacing of computer-generated stereoscopic imagery, high-resolution colour and developments within lenticular lens manufacture, the accuracy and complexity of lenticular imagery has grown apace. This knowledge now feeds into a wide range of applications, from 3D television technology and gaming to medical research.



Figure 97.
Lannes de Montebello Possibly the First
Integram Taken Integram photo of Baby Alice
Globus (c. 1985–86)
20.32 x 25.4cm



Figure 98.
Lannes de Montebello with the
CrystalChrome Camera (c. 1985)

4.5. The Holographic Image

The final field for discussion within this section on the technical development of the image is holography. This method, although born of some of the technological advances already discussed, is very different to stereoscopic and lenticular approaches, as it can use laser light wave interference patterns to capture a complete three-dimensional image in one exposure. In basic terms, a laser light source sends coherent light waves onto an object from two or multiple angles, whilst the same beam is refracted, directed onto the emulsion plate, as a reference to the light scattered from the illuminated object. These pure *coherent light waves*¹⁰⁴ are reflected off points on the object and create interference wave patterns which are picked up by the high-resolution emulsion on the plate. Essentially, like ripples in water created by a rock breaking the surface, these patterns, once frozen, describe the form that created them, without the need for the object to be present. (Figure 99)

¹⁰⁴ 'Coherent light waves'- Two beams of light are coherent when the phase difference between their waves is constant ('Coherence', *Encyclopedia Britannica*, <https://www.britannica.com/science/coherence> [Accessed 24/10/19])_

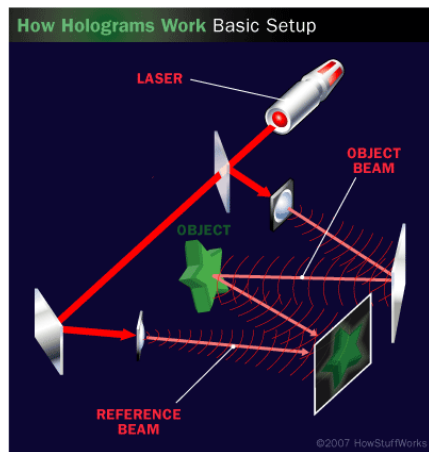

Figure 99.
Holographic Setup Diagram.
<https://science.howstuffworks.com/hologram1.htm>

As the term hologram, derived from the Greek *holos*, 'whole' and *gramma*, 'message' and suggests that this, like a photograph, records these disrupted wave patterns on a high-resolution photographic plate or film. This development draws on advances in photography and scientific microscopy, but its reference to light waves holds links to optical data gathering.

Based on principles of light interference and diffraction, research in this field of physical optics grew during the late 20th century, after World War 2.

It was only in 1948 that Dennis Gabor (1900-1979), a Hungarian-British electrical engineer working on first generation electron microscopes, devised a process to improve the quality of the image produced. This experimentation with the way a specimen scattered the light from the electron beam allowed Gabor to develop a process of recording this inference light wave pattern. He dubbed this 'holography'.¹⁰⁵

It is important to point out, however, that although many images are called holographic, not all are actually holographic. Some rely on lenticular and stereoscopic processes and others on historical theatrical techniques like the so-called 'Pepper's ghost' effect.¹⁰⁶ An example is the projection of the image of the model Kate Moss in the fashion designer Alexander McQueen's 2006 *Widows of Culloden* catwalk show in Paris, which was later shown as part of the V&A's *Savage Beauty* exhibition. (Figure 100)

¹⁰⁵ Sean F Johnston, *Holographic Visions: A history of new science*, (Oxford: Oxford University Press, 2006) p.16

¹⁰⁶ Peppers Ghost: Optical trick used to make a ghost appear on stage next to an actor. A sheet of glass is hung across the front of the stage so that the image of an actor standing in the orchestra pit appears to float on stage. 'More about Peppers Ghost', *Theatrecrafts.com*, <http://www.theatrecrafts.com/pages/home/glossary-of-technical-theatre-terms/more-about-peppers-ghost/> [Accessed 20/01/20]



Figure. 100.
Kate Moss Hologram (August 2011)
<https://www.flickr.com/photos/emiya/6020239684>

As production design Joseph Bennett states:

The Kate Moss hologram was a dramatic and emotional finale to the Paris show, with the ethereal figure of Moss shown floating inside a giant pyramid, set to the poignant soundtrack from *Schindler's List*.¹⁰⁷

On closer inspection and further reading it is clear that this is a contemporary take on a very effective Victorian parlour trick. Similar instances of misuse of the term 'holographic' have been applied to the projection of Princess Leia in the first of the *Star Wars* films and many others. (Figure 101)



Figure 101.
Princess Leia Hologram Could Be a Reality
The Guardian Newspaper, Science, Written by Ian Sample
(March 2013)

¹⁰⁷ Joseph Bennett, How we made Alexander McQueen's Kate Moss Hologram, *Creative Review* (13th March 2015), <http://josephbennett.co.uk/press/creative-review-how-we-made-alexander-mcqueen-s-kate-moss-hologram> [Accessed 10/9/19]

As Johnson points out in a 2011 article, holography, although seemingly out of fashion in the commercial and public arena, was very much at the forefront of scientific developments of the 19th and early 20th century .

Security holograms continue to evolve rapidly to keep one step ahead of counterfeiters. Holographic elements can combine optical properties such as reflection, focusing and magnifying and they have become an important feature of increasingly sophisticated aircraft visual displays, automotive lighting and laser barcode scanners. Holograms can also serve as key components in detection instruments by interacting with chemicals that alter their optical properties.¹⁰⁸

At this point it is important to briefly reference contemporary advancements in multi-dimensional imagery, as virtual headsets, 3D gaming and augmented reality¹⁰⁹ have become commonplace. We now have the ability to create totally immersive and interactive experiences, all constructed around exploiting our physiological and psychological spatial evaluation. We are no longer manipulating the margins between perceived structural reality and illusion, but have fabricated a parallel virtual reality to step into.

¹⁰⁸ Sean F Johnson, What Became of Holography? The Once-futuristic technology has less public glamour nowadays, but it still plays a current role in science. *American Scientist*: Vol 9. No.6, Published November – (December 2011). <https://www.americanscientist.org/article/whatever-became-of-holography> [Accessed 6/10/19]

¹⁰⁹ 'Augmented reality' – The result of using technology to superimpose information — sounds, images and text — on the world we see. (Jesse Emspak, 'What is Augmented Reality?' *Live Science*: (June 2018), <https://www.livescience.com/34843-augmented-reality.html> [Accessed 10/11/19])

5. Material Process

5.1. Introduction

As has been discussed, glass as a material has its own optical qualities, but can the use of glass facilitate an expansion of the visual depth and three-dimensional intensity we perceive from a two-dimensional image?

Is it possible to mesh contemporary 3D image technology within the techniques of studio glass practice?

The intention of this practical research is to focus on the creation of a spatial image in glass, to challenge the viewer's perceived understanding of the image and, through perceptual illusion, extend the image beyond the physical boundaries of the glass form. This almost holographic notion of the image is something that exists within modern technology but has not yet been fully examined and exploited using the medium of glass. It should be noted that the objective for this new conception of an image in glass was to create imagery which functions from an analogue standpoint rather than the employment of moving image, LED or digital screen-generated holography. That is, these works should communicate and engender observed depth or spatial reference solely through a combination of two-dimensional imagery and the viewer's interaction with the works by locating the generation of this illusionistic or 'virtual space' in the onlooker.

With this in mind, it is important to establish that my aim is to devise a new methodology that specifically addresses how a two-dimensional image can be understood as a three-dimensional perception in glass, rather than focusing predominantly on the context of that image.

Technically, the aims for this research are as follows:

- To ascertain how a two-dimensional image could successfully be suspended within glass. Examination of the various techniques and media to be employed.
- To assess the approaches that could be adopted in order to create an illusion of increased space, using a two-dimensional image that extends beyond traditional pictorial and illustrative paradigms.

- To examine stereoscopic and lenticular knowledge to establish whether the methodology of this relatively contemporary technology could be applied to studio glass applications.

Within this strand of the research, the importance of creating an accurate, industry-standard lenticular lens in glass cannot be understated. This is something that, at the start of this research, had not yet been achieved with this substrate. The creation of such a glass lens would be an original and significant development which could form synergies across art, design, architectural practice and commercial print systems.

First, it is important to note that this research is set in both a studio and digital context. Within the studio, testing was carried out using accessible art glass techniques and equipment. All production processes were kiln based: for example, fusing, slumping and casting glass, in addition to cold grinding and polishing processes undertaken using a combination of hand lapping and machine-orientated practices. Although workshop set-ups do vary depending on the techniques used, this equipment is generally present in a typical studio glass workshop, and so techniques developed through this research project are accessible to the wider glass community.

The digital aspect of this research was limited to basic equipment such as a generic laptop resource and inkjet printer. The software employed was predominantly basic design software with the addition of one specialist lenticular program which is readily available as a download for anyone interested in this field. I should also mention that my digital capabilities in operating this software at the start of this research were modest, and specialist knowledge has been self-taught over the duration of the project. Again, all of the digital applications and processes are accessible to the glass art practitioner, making this research viable and pertinent.

5.2. The Image and Glass

As indicated in the previous section, initial tests set out to explore the ways in which an image can be created in glass.

Drawing on over twenty-five years of knowledge and material understanding in my own work and lecturing practice enabled the selection of the most appropriate techniques and materials for the task. The medium used had to withstand firing onto and between glass sheet at temperatures of up to 810° C, without movement or loss of detail. A general monochrome image was created digitally for the purpose of this test. (Figure.102)

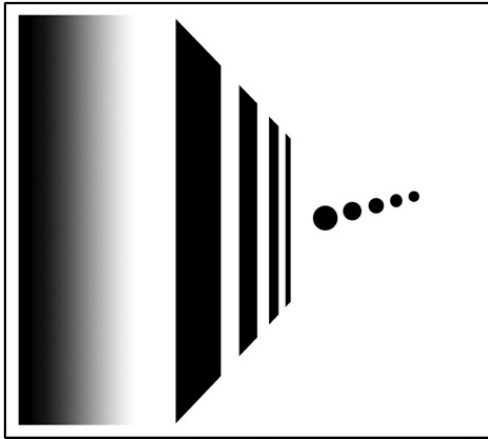

Figure 102.
Test image 1
Digitally produced. 8cm x 9cm

The design of the test image allowed for a graduation of tone, fading from dark to light, and a range of linear widths and precise marks, all elemental tools in creating traditional tonal depictions of three-dimensional space on a pictorial plane. The effectiveness of the chosen material and process was then tested with regard to embedding a precise and comprehensible pictographic reference within the glass.

It should be observed that in studio glass, artists are aware that not all glass types are compatible with one another, and issues of incompatibility will create stress within the glass, causing the work to crack either during or after firing¹¹⁰. This knowledge dictates that makers choose their glass type based on the process and effect they wish to achieve; many artists work with the glass of one or perhaps two particular companies. It is for this reason that these first tests were carried out using Bullseye glass, a soda-lime glass, which I use in my own practice for fused glass projects.

The techniques implemented to create this test image consisted of sandblasting, hand-applied ceramic underglaze enamels, silkscreen printing and ceramic digital transfer or decal.

Sandblasting

For the sandblasted sample a digital resist was created, employing the test image and adhered to a sheet of glass. This was then sandblasted to create a frosted, or engraved, reference of the image on the surface of the sheet of glass. The resist was

¹¹⁰ Daniel W. Schwoere, 'Compatibility of Glasses, COE Does Not Equal Compatibility', *Bullseye Glass Co.*
https://www.bullseyeglass.com/images/stories/bullseye/PDF/TechNotes/technotes_03.pdf
[Accessed 1/04/19]

Exploring the Optical Perception of Image Within Glass

then cleaned off and the sample topped with a clear sheet of glass, sandwiching the image within it, ready for firing.

Results

Image/Pigment	Technique	Effect	Effectiveness
Sandblasting	Sandblasted image onto a sheet using a digital resist. Fused between two sheets of glass	A very faint image created due to the trapping of small bubbles in the pattern of the sandblasted image.	<ul style="list-style-type: none">- Image very faint and in parts unreadable- No tonal graduation- No ability to add colour

[See Appendix II: A. 1.](#) for further details of the firing process.

Underglaze Enamels

The next sample application and technique was painted ceramic underglaze. Having trained in both ceramics and glass, at degree and master's degree level, I had empirical knowledge of the basic chemical properties of both ceramic glaze technology and glass. This combined knowledge is crucial in order to gain a holistic understanding of glass and glaze, essentially the same substrate. Ceramic underglaze enamels are used widely within a ceramic process to add additional colour or illustrative reference to clay forms: as the name suggests, these sit happily under a glaze, and because of this, with the odd exception, these enamels are able to be fired to high temperatures without burnout. As this substrate is designed to be covered in a glass, it will generally fire in a low oxygenated environment, making it a suitable choice of medium for this test. My stained-glass training, using tracery paints for glass window panels, allowed instinctive decisions regarding the use of a water-based suspension, a product known as Universal Medium. This, mixed with the powdered enamel pigment, facilitates a solution which adheres to the surface of the glass.

The mixture was produced to a consistency similar to gouache paint and was brush-painted by hand directly onto sheet glass, using the test image as a guide beneath. Then the enamel was left to dry before the addition of a top sheet of glass.

Results

Image/Pigment	Technique	Effect	Effectiveness
Ceramic underglaze Enamels	Hand painted onto sheet glass. Fused between two sheets of glass	Pigment varies in weight from black to grey, with brush marks apparent. As this is hand painted it also lacks precision.	-No tonal graduation -Weight of line varies -Lacks precision

[See Appendix II: A. 2.](#) For further details of the firing process.

Silkscreen Printing

The silkscreen printing process is one which is used on a wide range of materials, from paper to fabric, metal, ceramic and glass. Production of an image on a silkscreen is very similar regardless of the material on which it is intended to be printed. Decisions do, however, need to be made concerning the gauge of the screen and its overall size, to ensure the print medium will pass through the screen cleanly without a bleed or blockage, and that the image required fits comfortably within the boundaries of the screen, to enable the snap-off and fabrication of a crisp image when printing.

Having made my silkscreen using the specified test image, I proceeded to print this directly onto sheet glass using the same ceramic underglaze used in the previous test. This powder pigment was mixed once again with a water-based suspension medium, but the consistency was made thicker to reduce the possibility of image bleed through the screen. With this process I prefer to pre-load my screen: that is, to apply the print medium directly to cover the image on the screen, making the consistency of the mix crucial in avoiding the image bleeding onto the glass below. Once printed, the image is left to dry on the base glass before adding the top sheet.

Results

Image/Pigment	Technique	Effect	Effectiveness
Silkscreen Print	Ceramic underglaze silkscreen printed directly on to sheet glass. Fused between two sheets of glass	Pigment is consistently even and precise. Black colouration is strong, almost opaque.	-Good strength of colour -Precise mark capability -No tonal graduation

[See Appendix II: A. 3.](#) for further details of the firing process.

Digital Ceramic Transfer

Transfer print onto ceramic, as a decorative process, was established within the ceramics industry in the mid-18th century.¹¹¹ Contemporary digital ceramic transfers offer a wider range of colours, the design versatility of a digital image and a high level of detail if needed. They can be made to be printed as desired from very small-scale imagery up to an A3 scale and applied onto glazed ceramic or glass substrates. As these are printed on digital laser printers using ceramic toner, the test image, once emailed to the print bureau, Fotoceramic Ltd, was posted back as a transfer. These were applied onto the glass surface using the water-slide method,¹¹² excess water and any air bubbles removed and allowed to dry before putting the top sheet of glass in place.

All the image samples were then placed into the kiln on a bed of ceramic fibre paper, to act as a separator, and fuse-fired together. (Figure 103)

Results

Image/Pigment	Technique	Effect	Effectiveness
Digital Ceramic Transfer (Decal)	Ceramic digital transfer applied to sheet glass. Fused between two sheets of glass	Pigment is consistently even and precise. Black colouration is slightly transparent.	-Good strength of colour (using black) -Precise mark capability -Tonal graduation

[See Appendix II: A. 4.](#) For further details of the firing process.

From these basic tests it was concluded that the digital ceramic transfer, or decal process, offered the most potential. Not only did it deliver a consistently even and precise mark; it also offered the flexibility of tonal graduation.

(See Appendix II:B1-8, for detailed results & firing schedules)

¹¹¹ Paul Scott, *Ceramics and Print: Historical and Industrial Background*, 2nd. ed. (London: A&C Black, 2002), Chapter 1, pg19.

¹¹² 'How to apply transfers', *Fotoceramic*, https://www.fotoceramic.com/p/how_to_apply_transfers.php [Accessed 12/4/19]

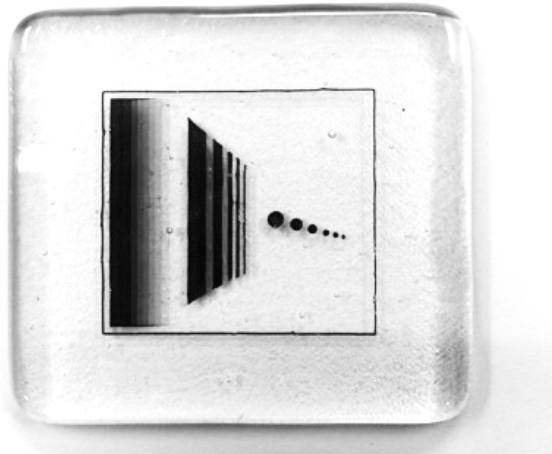

Figure 103.
Fused digital transfer sandwiched between 2 sheets of glass.
8 x 9 x 0.6cm

The fusing process had allowed the creation of an image within a thin envelope of glass, but the next step was to encapsulate that image within a larger volume of glass. Once again the image had to remain static, without distortion or loss of detail.

(See examples below in Figure.104-106).

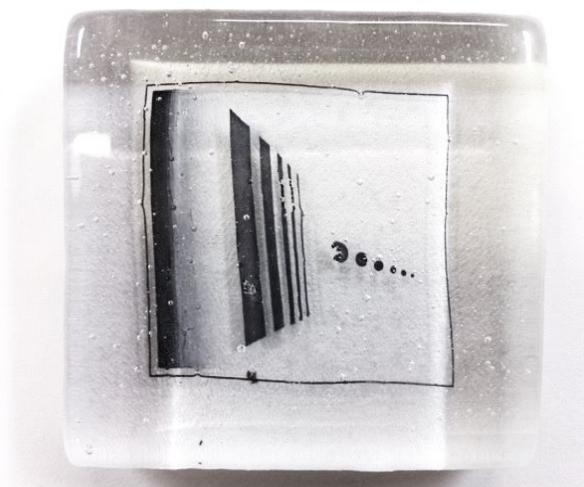

Figure 104.
Front face view of a test casting
8cm x 9 x 1.8 cm With a pre-fused transfer image set within a
block of glass. Here, visible flexing of the image is apparent.

Top to bottom movement of the image over three different casting firings (Edge-on view)



Figure 105.
Firing Schedule 1



Figure 106.
Firing Schedule 2
Top Temp down from 810 to 805°C. Hold/soak reduced from 1.5hr to 1hr



Figure 107.
Firing Schedule 3
Top Temp down from 805 to 800°C. Hold/soak reduced from 1hr to 45mins

As a result of the iterative approach, in order to produce a flat static image, the glass type used during testing was changed from Bullseye to Spectrum 96, another soda-lime glass. Spectrum 96 is supplied in very flat, untextured, bubble-free sheets, and was found to be more successful in limiting the distortion of the image in both the first fuse and second lamination firing due to its unaerated structure and consistency.

Further systematic testing regarding the development of a firing schedule allowed the pre-fused glass element, with the image captured internally, to be suspended within a cast block of glass without distortion or movement on either axis.

In order to maintain a static, precise image, this became a kiln-fused lamination process,¹¹³ rather than a liquid casting of the glass. ([See Appendix II:B1-8](#), for detailed results and firing schedules)

Image Intensity and Transparency

The lamination of this image within a thicker block revealed a weakness in the depth of the black pigment of the ceramic transfers. Its slight transparency created a loss of tonal range and depth, impacting on the perceptual intensity for the viewer.

Obviously ceramic transfers are designed to be applied to a glazed clay body. This is an opaque material, and so there is no necessity for transfers to print in a consistent opaque pigment, as on a white or solid ground they have sufficient strength. Analysis of this trait prompted a broader questioning of how the intensity of other colours would perform when fired in this way.

It is widely documented that when coloured pigment is used in the ceramic transfer process on or in glass it can cause anomalies. Colours can fade, burn out totally or appear as a muddy version of the original desired colour. Within the ceramics world it is accepted that red and yellow colours in glazes are oxygen sensitive and require sufficient levels to be present during the firing to reach a good intensity of colour.¹¹⁴ Also, the top firing temperature of a transfer can impact on the colour strength, and even its transition to full concentration, as noted by Digital Ceramics Ltd on their website: vivid reds and greens are achieved by firing to a top temperature of 780-800° C.¹¹⁵ However, as digital ceramic transfer manufacturers are guarded when asked about the oxides etc that are used within their print pigment, it is difficult to test this with any accuracy. Printer toner in general can vary between the two colour sets CMYK and CRYK and whether the toner is fluxed or unfluxed. Also, a significant consideration is any effect initiated by the glass type within which the image is fused. The chemical composition of the glass can similarly impact on the colour and intensity achieved, in addition to its softening and melt properties affecting the oxygen levels available. Although this was of great interest I did feel that, at this stage, it was important to remain focused on the main aim of this element of the investigation, to successfully place a static image within glass. And I recognised that, within this wider enquiry, there would be too many variables and unknowns to sustain accurate testing.

¹¹³ Manufacture (something) by bonding layers of material together. (‘Animate’, *Oxford Dictionaries*, <https://en.oxforddictionaries.com/definition/laminate> [Accessed 16/05/19])

¹¹⁴ Edward Orton Jr, ‘Orton Firing Tip: Firing Red Glazes’, *Laguna Clay*, <http://www.lagunaclay.com/support/orton-firing-redglazes.php> . [Accessed 12/04/19]

¹¹⁵ ‘Ceramic Transfer’, *Digital Ceramics Ltd*, <http://www.digitalceramics.com/sections/ceramic-transfer.php> [Accessed 10/04/19]

I took the decision to maintain fixed parameters, using Spectrum 96 glass and the digital ceramic transfer bureau Fotoceramic Ltd. I was able to ask for the decals to have a higher quantity of toners applied. I subsequently perfected the firing schedule to perceptually strengthen the colour intensity within the glass. (Figure 108)

(See [Appendix II: B.5-8](#), for detailed results & firing schedules)

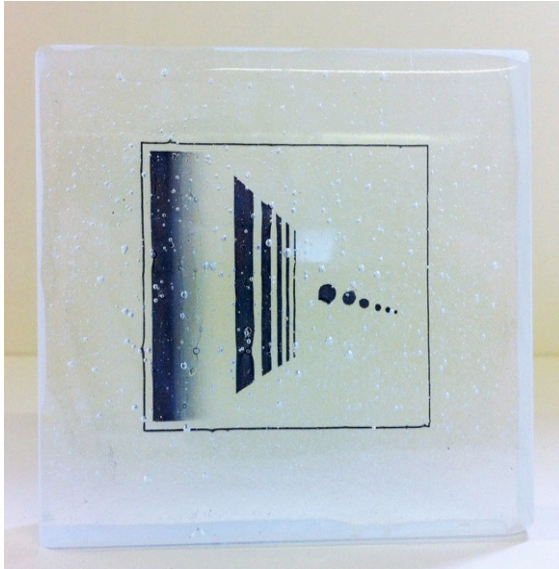

Figure108. Laminated glass test with digital decal transfer

The utilisation of a monochrome palette, as one of the set parameters for testing, facilitated pragmatic analysis of both the ceramic transfer material and glass firing schedule.

5.3. The Reverse Perspective Illusion

Resolution of the first technical aim, to create and capture a 2D image which would remain inert within a glass block, allowed an exploration of the way this ceramic transfer image could be used to create perceived additional depth in a glass form.

As discussed in the previous chapter, glass has a wide range of optical properties, such as magnification, diffusion of light and lens capabilities, all of which have been exploited within contemporary works of art. This project's intention is to use specifically the image and its composition and/or position within the glass to construct an optical illusion of depth.

In developing my first practical work addressing the potential fabrication of this illusion, I referenced the work of contemporary painter [Patrick Hughes](#) and his signature 'reverse perspective' technique. As mentioned in a previous chapter, [\(2.3\)](#), this misapprehension of his paintings permits the viewer to feel as though they are

Exploring the Optical Perception of Image Within Glass

almost standing within the composition as they move around the work. My objective was to start with a vocabulary of perspective-based imagery applied to a form, as seen in Hughes' work. But in addition, I aimed to preclude the viewer's understanding of this technique further by casting the image and form within a solid block of glass with a smooth outer surface, so that no understanding of the illusion was immediately offered. I found the application of this illusionistic technique in glass intriguing, as it created an original work which pushed the exploitation of this visual misconception to produce an optical paradox. (Figure 109).



Figure 109.
Helen Slater Stokes *Treeline* (2017)
Cast glass with digital decal transfer. 48.5 x 25.5 x 11 cm

An internal form similar to the canvas shapes adopted by Patrick Hughes was designed and produced using investment material. (Figure 110).

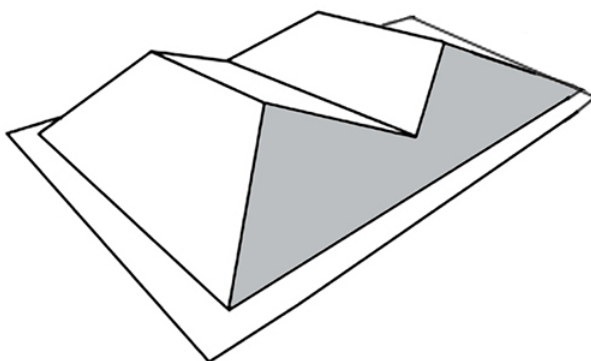

Figure 110.
Digital design from the internal form

Exploring the Optical Perception of Image Within Glass

This was then set into the back of a rectangular glass casting mould. The illustration of two rows of trees receding into perspective was designed in Photoshop and produced as a digital ceramic transfer. This image was then fired between two sheets of glass.

As in the previous tests, this fuse-fired element was positioned on the internal form, within the investment mould, and the mould packed with further sheet glass and casting cullet.¹¹⁶

([See Appendix II: C 1](#) for detailed results and firing schedules)

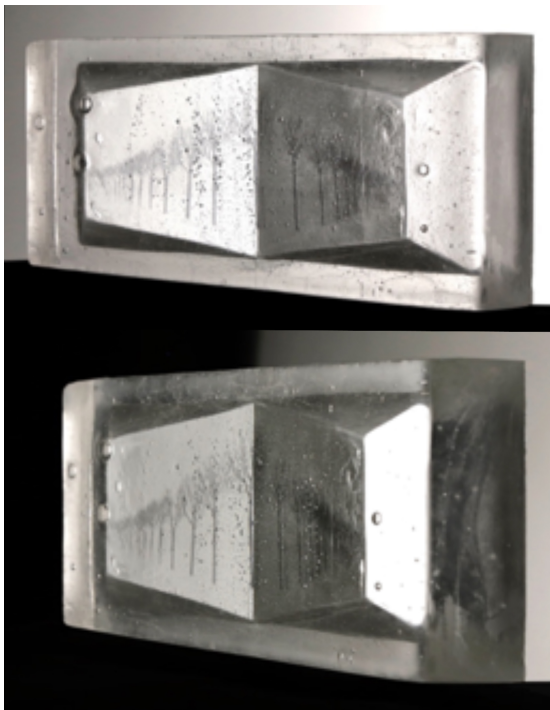

Figure 111.
Helen Slater Stokes *Treeline* (2016)
Cast glass with ceramic transfer. 28.5 x 25.5 x 11cm

The images above show the phases of the illusion as the viewer moves around the work. When viewed square on, the observer is able to quickly comprehend the perspectival image they are looking at, but as they move this becomes less certain and more equivocal. The two lower images illustrate how the internal form, which the image is placed upon, begins to shift and flex from a certain viewing angle and in doing so creates a confused sense of the space within. (Figure.111.)

¹¹⁶ Casting “cullet,” the industry term for furnace-ready recycled glass. Supplied as random glass rocks, chunks or crystals.

Treeline illustrates how this manipulation of perspective and form can start to perplex the onlooker and play with their reading of an image, inventing an obscured and ambiguous space within the glass.

The second piece in this series, focusing on reverse perspective, aimed to address linear tonality and visual interposition in addition to the previously tested cognitive cues regarding perspective. (Figure.112). By applying these additional perspectival tools, it aimed to enhance the perceived spatial qualities of the image, by reinforcing the reader's comprehension of the pictograph with overlapping tonal references. Tonal graduation is a recognised and learnt optical cue for the brain when analysing depth. Exploitation of our intellectual understanding of visual perspective was applied, sending the onlooker strong optical cues which enhance the effect of depth.

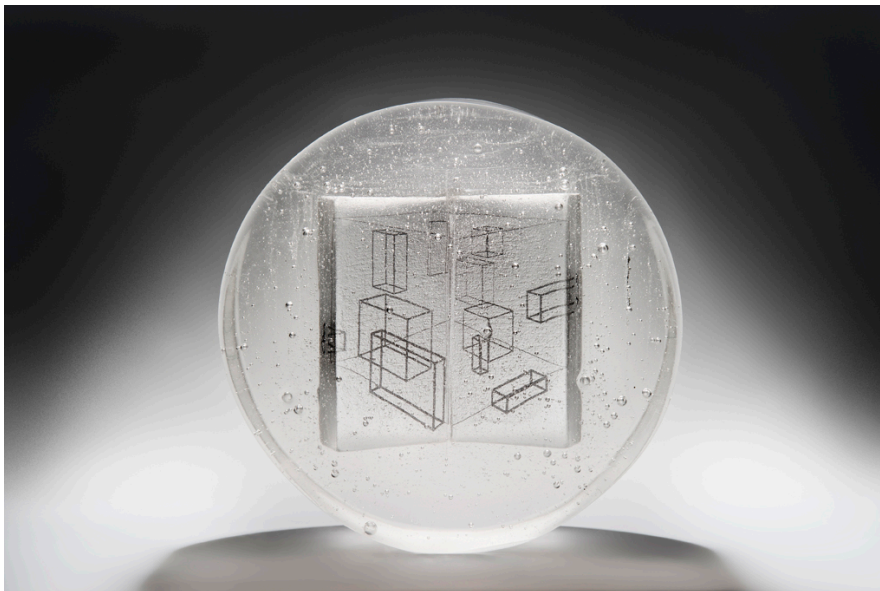

Figure 112.
Helen Slater Stokes *Geometric Perspective* (2017)
Cast glass and ceramic transfer.42 cm diameter x 12 cm deep. Photography by Ester Segarra

The technical processes used in creating this work, although almost identical to *Treeline*. (Figure 111), were not without issues. Here complications regarding formal *residual stress*¹¹⁷ hampered the production of this work. These internal stresses were created on cooling and manifested as internal cracking across the piece. It was determined after extensive testing that these were due to the steep angle of the internal investment form and the distance of this form from the bottom edge of the

¹¹⁷ Internal residual stresses arise in glass-ceramics upon cooling down from the crystallisation temperature. These stresses are due to the thermal expansion and the elastic mismatch between the crystalline and glassy phases.(Francesca Serbena, Edgar D. Zanotto, 'Internal Residual Stresses in Glass-ceramics: a Review', *Journal of Non-crystalline Solids*, 358.6-7 (April 2012), 975-984 <https://www.sciencedirect.com/science/article/pii/S0022309312000555> [Accessed 12/04/19]

Exploring the Optical Perception of Image Within Glass

casting. Once adjustments were made to the internal form this piece could be successfully fired. (See Appendix II: [C.1](#) and [C.2](#), detailed results and firing schedules).

Within the casting the images of cuboids sit in what we recognise as three-dimensional perspective. This is reinforced by linear tonality, offering cues to distance through strength and width of line and the overlapping of the wire frame forms fortifying these depth references for the viewer. (Figure 113.)

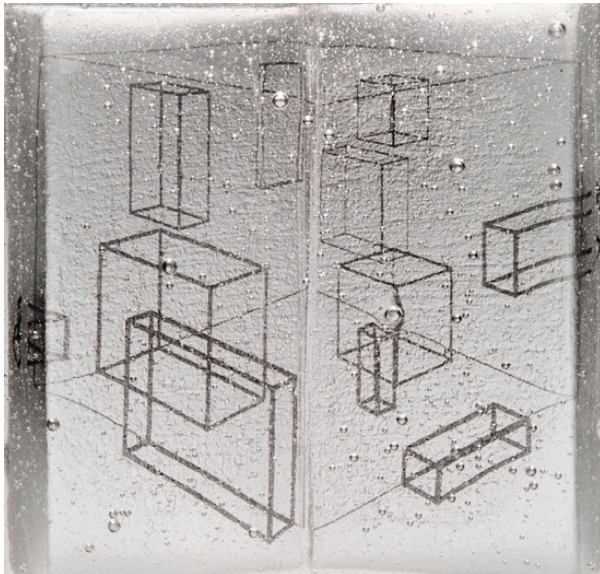

Figure 113.
Helen Slater Stokes *Geometric Perspective* (Detail) (2017)
Cast glass and ceramic transfer. 42cm diameter x 12cm deep

Here the images, instead of coming towards us, sit on a form that reverses their position as we perceive it. They are at an angle away from the front of the piece towards the back of the casting, like text on the pages of a book, and move away from, rather than towards, the viewer. Here, it is the difference in tonality, via the linear weight, the overlapping of shapes and the familiar nature of a cube in perspective, that tricks the observer into this three-dimensional visual interpretation.

Optically, as in the previous work, *Treeline*, (Fig.111), this piece starts to create the notion of confused space within the glass when viewed from a narrow side angle. (Fig.114).



Figure 114.
Helen Slater Stokes *Geometric Perspective* (2017)
Cast glass with ceramic transfer. 42cm diameter x 12cm deep
Photography by Ester Segarra

Of course, the moment of paradox, this shift in perception, can be altered by modifying the angle of the internal form on which the image sits. A more severe or sharper internal angle will trigger a contradiction in spatial perception earlier in the viewer's movement around the work.

The role of the observer in this work is something also to be considered, as they become the dynamic stimulus for the work, as opposed to a passive onlooker. The perceptive illusion is centred on the spectator, as the work no longer functions if not viewed or interacted with. Here, unlike pictorial renderings of landscape or environment, these schemata correspond to a virtual optical location whilst applying an analogue methodology. The work is perceived and interpreted individually. This revelation becomes apparent when trying to document the 'reverse perspective' works. Photographic documentations proved inadequate, reproducing only, via one camera lens, a monocular view of the works, a flat image of one eye's perspective. Video became the main vehicle to capture works from then on, but even this struggled to grasp the depth I perceived whilst analysing the pieces.

Subsequent design work initiated the study of other ocular illusionistic techniques.

5.4. The Commercial Lenticular Lens

As explained in [Chapter 4](#), stereoscopic and lenticular technology works on the premise of creating one image, fabricated using strips from multiple images of the same composition, taken from differing angles. These strips of image are aligned with the strips of cylindrical lenses, or lenticules, when placed under the lens. The reflective qualities of the lens enable the viewer to optically receive, to each eye, a differing perspective on the scene and the brain then uses biological and psychological cognitive processes to create a three-dimensional perception of the image.

Within this context, my technical research attempts to ask a much more specific and original question; can stereoscopic and lenticular technologies be utilised in order to create glass pieces with an enhanced virtual sense of space and depth? Can an accurate lenticular lens be made in glass?

The rudiments of this idea have previously been delivered by contemporary artists such as Rufus Butler Seder, in his glass lenticular tile murals (Figure 115) which animate. Drawing upon his previous career in film-making, Seder created an effective lenticular effect from a production line tile, produced using press-moulding techniques; he went on to develop this into what he calls 'Lifetiles'.¹¹⁸ Although very coarse, with a low lenticules-per-inch relation, this eight-inch tile, when assembled, can effectively convey animated imagery in a mural. Zsuzsanna Korodi, a Hungarian glass artist, has also explored ideas around the optical lenticular lens. Korodi uses halved glass rods, which are ground and fixed to printed or painted coloured patterns, replicating lenticular lens strips (Figure 116). These again allow an abstract animation of the pattern. Notably, prior to this research, no one has created an accurate industry-standard lens in glass.

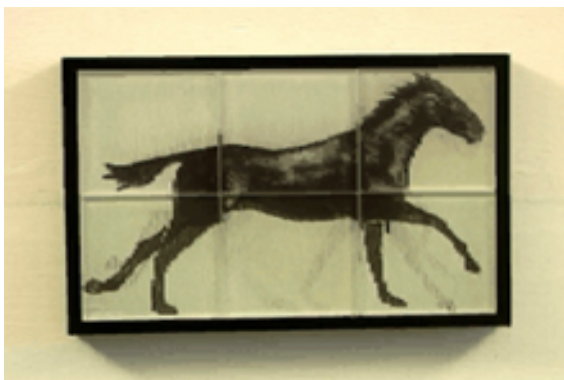

Figure 115.
Rufus Butler Seder *Large Galloping Horse*
– 6 tiles, (Made to order). 40.6 x 61cm

¹¹⁸ Lifetiles', *Rufus Lifetiles*, <http://www.rufuslifetiles.com/about.html> [Accessed 10/08/14]

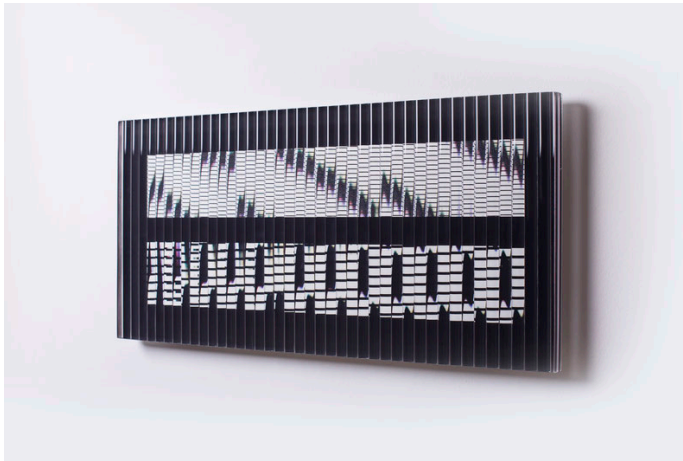

Figure 116.
Zsuzsanna Korodi *Grid III* (2017)
Cut, glued, polished glass and uv paint. 30 x 60 cm
By kind permission of the artist

Technically the testing and development of this aspect of the research needed to be carried out in two ways: first, the development of an accurate kiln formed glass lenticular lens and second the creation of a precise lenticular image calibrated to match this lens.

Lens Types

As seen in the Bois-Clair *Double Portrait of King Frederick IV and Queen Louise of Mecklenburg Gustow of Denmark* (1692), mentioned in [Chapter 4.1](#), lenticular lenses can be very basic, relying on a simple triangular formation. (Fig.117).

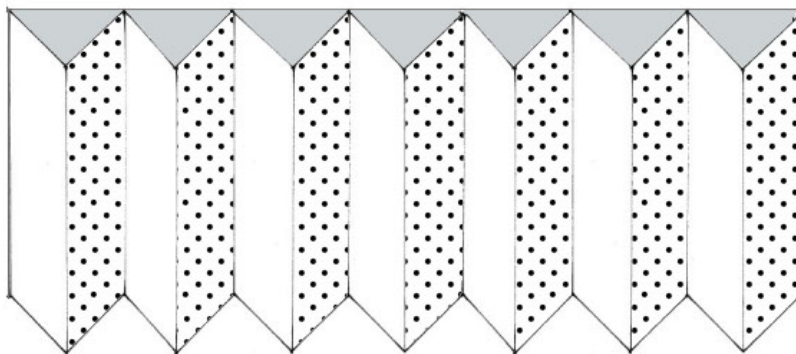

Figure 117.
Diagram of a triangular formation lenticular

In this example the observer can see either a white panel with black dots, when standing to the right of the lenticular, or simply a white panel, when standing to the

Exploring the Optical Perception of Image Within Glass

left. It relies on rudimentary vision: no illusion is created here, the eyes simply see either one image (a dotted or a white surface), depending upon from where the panel is viewed. Also, when not in the correct position – that is, standing square on or slightly off centre, a confused view of both surfaces is seen. This methodology has been used for centuries to generate a lenticular image and is an extremely simplified version of current lenticular practices. A recent example of this type of lenticular approach is *Confluence* (Figure 118 and 119), by Jeffrey Sarmiento, created in 2016 using screen-printed and kiln formed glass. As in the illustration above, this work allows the observer to see two differing images when viewing the work from each end.

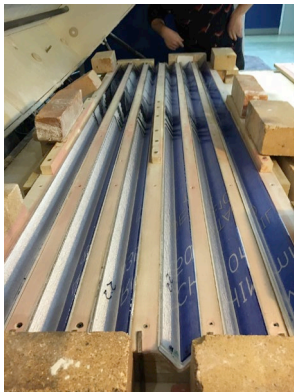

Figure 118.
Jeffrey Sarmiento
Confluence (2016)
Kiln set up image

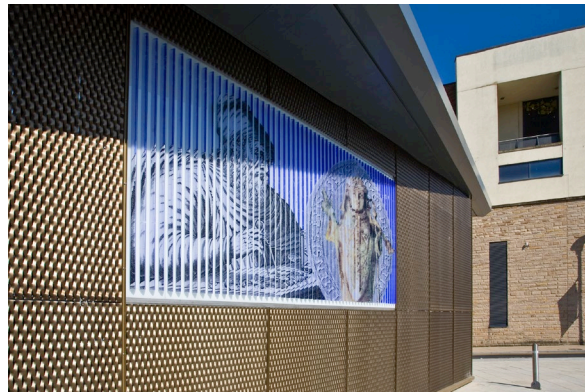

Figure 119.
Jeffrey Sarmiento *Confluence* (2016)
Screen-printed and kiln formed glass, Bishop's Mill at
Freemans Reach, Durham, UK
By kind permission of the artist

However, current commercial lens technology is far more sophisticated than this. It employs curved lenses and applies subtle changes in the angle of this curve to affect how the image is perceived, either as a flip image¹¹⁹, static 3D image¹²⁰, animation¹²¹ or morph¹²². These lenticulars use an array of magnifying lenses, calculated to magnify different images when viewed from slightly different angles. This contemporary type of stereoscopic approach has more in common with [Charles Wheatstone's stereoscope](#), (1838), as it exploits our binocular capability to receive two images simultaneously. And here, rather than the viewer having to move to each

¹¹⁹ 'Flip Lenticular Printing' - A technology where lenticular lens are used to produce printed images which flip from one image to another. 'Lenticular Printing', MJCP, . <https://www.mjcp.co.uk/lenticular-printing> [Accessed 1/04/19]

¹²⁰3D lenticular is the illusion of depth on a normally flat surface. ('What is Lenticular?' *Virtual Images*, <http://www.virtual-images.com/what-is-lenticular> [Accessed 1/04/19]).

¹²¹ Animation Lenticular – A series of images coming together to create an animation much like a short movie clip.'Animation Effect', VICGI, <http://www.vicgi.com/animation-effect.html> [Accessed 1/04/19]

¹²² The conversion of one image into another gradually is used to create the illusion of transformation. 'Morph Effect', VICGI, <http://www.vicgi.com/morph-effect.html> [Accessed 1/04/19]

end of the lenticular to view each image, the ocular parallax¹²³ created by the space between our eyes, combined with cognitive and biological processes, create the perception of three-dimensional depth, and, once tilted, on either axis, the image can flip, animate or morph. The effects achieved with contemporary lenses and printed imagery are stunning and far exceed the illusions perceived using triangular or corrugated style lenses.

With this in mind, my tests in glass started by using the model of the contemporary curved lenticular lens.

The Industry-standard Acrylic Lenticular Lens

It is important here to reference the nature and sophistication of contemporary lenticular lens and print practice. In order to create a methodology regarding the production of a lens and a lenticular image it was crucial to align myself with current commercial practices and to collaborate with industrial manufacturers.

For these purposes, I was fortunate to be able to work in collaboration with an industrial caster, Priory Castings Ltd, in addition to working with the holographic and lenticular print company Tribal 3D Ltd, during this project.

Lens Manufacture

Lenses are formed from a variety of plastic resins: Acrylic (PMMA), APET, PETG, Polycarbonate, Polypropylene, PVC and Styrene. Manufacturing processes can vary from sheet-fed presses to extrusion techniques. In general, most lenses are manufactured from Acrylic or PETG. PETG stands for Polyethylene Terephthalate Glycol and is a water clear material designed for a range of applications.¹²⁴ This enables a flexibility in the material when either printing directly on to the back of the lens or adhering an image via lamination in a roller system.

Commercial lenticulars are classified within four different categories: flip, 3D, animation and morph images. As the groupings suggest, they refer to the function of the image and lens. That said, the standard lens sheets conform to just two main types, 3D and flip. These can have either vertical or horizontal lenticules - the name for the individual strips that make up a lens - and the direction of these is determined by how the final lenticular image will be viewed. For example, an animated lenticular

¹²³ Parallax- The effect whereby the position or direction of an object appears to differ when viewed from different positions, e.g. through the viewfinder and the lens of a camera. ('Parallax', *Oxford Dictionaries*, <https://en.oxforddictionaries.com/definition/parallax> [Accessed: 12/04/19])

¹²⁴ Lenticular Lenses, *Humaneyes* (2015) <http://ga.humaneyes.com/learn/lenticular-lenses> [Accessed 15/10/16]

image, positioned to be viewed whilst the viewer is on an escalator, might have horizontal lenses to allow the imagery to transition as the observer travels from the bottom of the image to its top. A lenticular poster that the viewer walks past in a shop window, on the other hand, would have vertical lenticules, as it is read from either direction, as if a landscape, across from one edge to the other.

The crucial difference between a flip and a 3D lens is the viewing angle. Here the viewing angle references the range of angles within which the viewer can see the entire lenticular image. This angle is calculated based on the maximum angle at which an idealised ray of light can leave the image through the correct lenticule. (Fig.120).

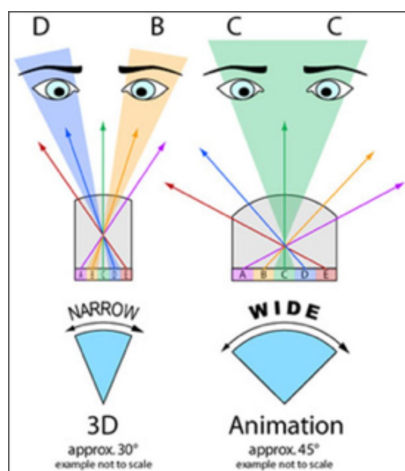

Figure 120. Lenstar Lenticular Ltd Diagram explaining the angle of view for 3D and animation lenticular lenses

As the diagram illustrates, a lenticular sheet produced to mesh with a 3D designed image has a narrow viewing angle, typically less than 30 degrees. When viewing this type of image, optical movement is required across the image, a rocking motion or movement of the image itself, to accommodate this small viewing angle. Flip or animation image sheets, on the other hand, have a wider viewing angle, generally higher than 40 degrees, with morph and animation images, regarded as an advanced form of flip, also benefitting from this wider viewing angle.

One must also consider the size of the final image being created when selecting a lenticular lens with which to work. In general, the LPI (lenticules per inch) of the lens sheet decreases as the image size increases, so a coarser lens, such as 10lpi, would be used on a large A0 poster whereas a small postcard or business card would require a very fine lens of perhaps 60 – 80lpi. In commercial printing, this is dictated by meshing or accurate aligning of the image. A large lenticular image proves difficult to align perfectly with a large fine lens. So here, due to the increased width of

the lens lenticules, a low LPI sheet is easier to align to the image than a high LPI sheet¹²⁵.

Next the viewing distance of the lenticular must be taken into account. This is inversely proportional to the LPI of the lens sheet. A closer viewing distance would typically necessitate a higher LPI than a longer viewing distance¹²⁶. This need for a finer lens when closer to the viewer not only aids the precision and effectiveness of the lenticular but avoids the observer being distracted by the obvious wide lenticules on the lens. Unsurprisingly, with a large-scale lenticular at a distance, optically the individual wide lenticules are not seen in detail and do not interfere with the perception of the image.

The Focal Point of the Lens

As discussed earlier, a lenticular lens has a front surface, which is determined by a series of semi-cylindrical lenses, and a flat rear surface. The back flat surface, on which the prepared image is located, must be consistently equally distant from the top lens surface in order to achieve the correct focal length. As the diagrams below explain, if this distance is too great or too small the image will appear confused, with ghosting¹²⁷ evident, as the viewer interprets a mix of left and right eye images. (Figure 121). This confusion of an image reading, due to a lens fault, is known in the industry as 'cross talk'.

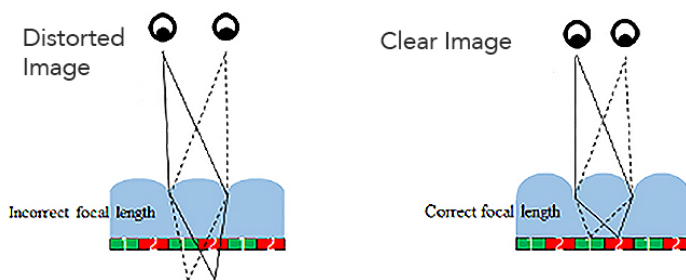

Figure 121.

Jee Hoon Sim et al Schematic diagram showing the relationship between the focal length and crosstalk (2018)

By kind permission of the artist

So, as you can see, the thickness and consistency of the lens is also crucial in ensuring an accurate meshing of interlaced lenticular image to lens.

¹²⁵'Choosing the Correct Lenticular Lens Sheet', *Micro Lens Technology, Inc.*
http://www.microlens.com/pages/choosing_right_lens.htm. [Accessed 12/04/19]

¹²⁶ Ibid.

¹²⁷ Ghosting – An undesirable result of lenticular printing which happens when more than one image is visible at certain viewing angles ('How to Prevent Ghosting', *VICGI*,

http://www.vicgi.com/How_to_Prevent_Ghosting_20120113.pdf [Accessed 1/04/19]

]

5.5. Commercial Lenticular Image Printing

Another factor in selecting which lenticular sheet to use is the print process. Inkjet printers specify a lens which is 60lpi or less, due to the relatively low resolution of these printers. Most of these printers also have a thickness limitation ranging from 15 – 20mm, and their inks do not adhere to plastic sheets without having a receptive coating added to the sheet. As a result, with this print method images are printed onto a photopaper or film and then laminated to the back of the lens sheet.

Flatbed printers are much more versatile and can print onto media that is up to 2.5cm thick. This greater thickness capability, combined with UV curable inks, allows this printer to apply the image directly onto the lenticular lens. Resolution quality here is crucial, as fine lenses and complex images can be used. The resolution of flatbed printers in general allows an acceptable print quality for up to 30 or 40lpi designs depending on the system, but offset printing, as an alternative, offers a much higher resolution. An industrial offset system can print directly onto the lens sheet but has no limitations regarding the size or thickness of the sheet. The commercial norm for these printers is lens sheets of 60lpi or finer and a typical thickness of 35mm and 70cm in width¹²⁸.

5.6. Interlacing an Image

The interlacing of a digital image for a lenticular output is based on the combination of several images into a single image. This image must mesh, or marry up, perfectly with the lenses of the selected lenticular lens in order to create the illusion of three-dimensional depth. These multiple images can be produced in a number of ways: photography, digital images, hand drawn images or film stills, but it is essential that these images must be digitally compatible for interlacing. For this they need to be all the same size dimensionally (actual printable size), have the same resolution (dots per Inch), use the same file type (i.e. Jpeg, TIFF, PSD) and adopt the same colour system (RGB, CMYK, Grayscale). These images must gather different views of the scene intended to be captured as a lenticular image, in order to allow the viewer to seemingly see around the object in space.¹²⁹

As we know, 3D lenticular images are created based on the principles of binocular disparity. That is, when we see an object our right eye sees a slightly different image to that seen by our left. Simply put, this disparity between the two images allows our brain to calculate and perceive 3D depth. So, when creating an interlaced image, the

¹²⁸ 'Choosing the Correct Lenticular Lens Sheet', *Micro Lens Technology, Inc*
http://www.microlens.com/pages/choosing_right_lens.htm. [Accessed 12/04/19]

¹²⁹ Isaac Cheung, 3D Lenticular Printing Algorithm Illustrated Using Photoshop.
<http://www.vicgi.com/lenticular-interlacing-algorithm.html> [Accessed 21/10/15]

lens and image combined has to be able to clearly offer two different images, and these must be directed to and viewed by the correct eye.

The creation of this illusion requires the gathering of multiple images of the subject. Let's say a ceramic mug is our subject: allowing for disparity and viewing angle we need to take multiple images of the mug using a photographic slider bar. This enables us to capture several equally spaced shots of the mug, which are incremental along the slider and ensure that the camera is level at all times.

The number of images needed for this type of image is determined by the type of lens one plans to use - let's say a 20lpi lens and the print resolution one is able to print to. The higher the resolution the better, especially if one is working with very fine lenses, so for this example we will work with a 720dpi print quality. Using this information, the following algorithm can be used to calculate the number of images or frames needed.

$$N = R_{PR} / R_L$$

Where N = Number of consecutive pictures to be taken

R_{PR} = Resolution of the inkjet or colour laser printer

R_L = Number of lenticules per inch of the lenticular sheet that will be used

Using our example Number of images = 720/20

Therefore, the example would need 36 images taken of the mug. As specified, the printer can print 720 lines per inch (resolution) and we have selected a 20lpi lens to use for this image. Consequently, there will be 36 lines under each lenticular lens strip: these will contribute one pixel of their image to this lens group. See diagram Figure 125 for further clarity.

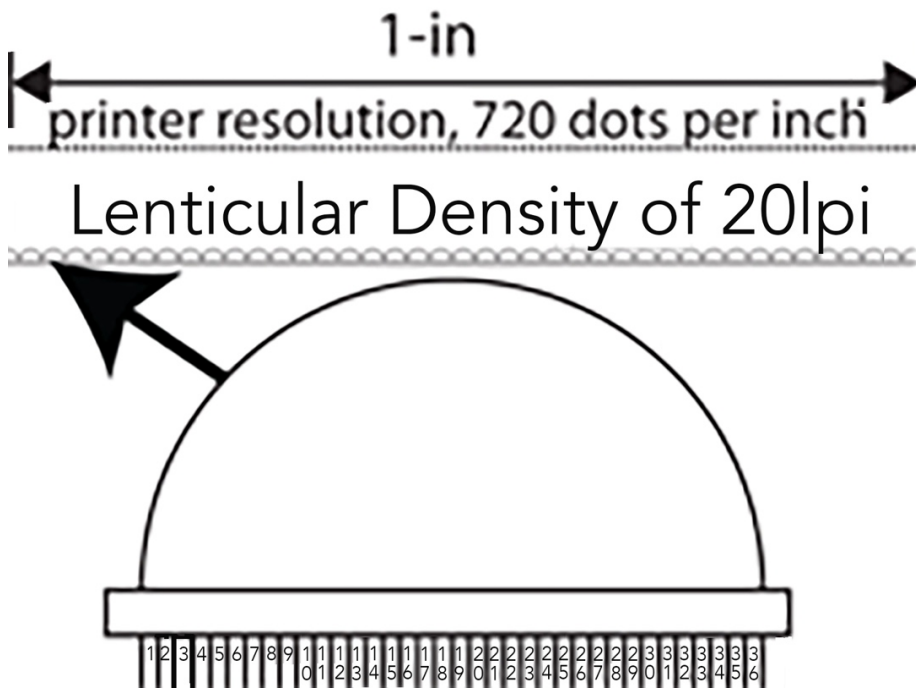

Figure 122.
Lenticular lens and image interlace diagram

The image above (Figure 122) clearly illustrates that the one-pixel strips of image 1 will be used sequentially for strip 1, 37, 74 and regularly thereafter. The second image will be cut into strips used sequentially in strip 2, 38, 75 etc.

Once this calculation is made, the only decision left is how this formula is applied to the images collated. In other words, which software one wishes to use in order to accurately cut and interlace these images. For this research I have worked with three different methods. Initial basic testing was carried out using Photoshop to create one-pixel wide cropping masks for each of the images on individual layers and combining these to achieve the final image. Although effective, this proved incredibly time consuming and open to human error when moving masks on each of the images in sequence. Next I used HumanEyes¹³⁰ software which, although very precise and quick, did not allow me to change the scale of the image output or the lens resolution. Many software companies sell more basic versions of their industrial software at a cheaper rate but limit the functionality of the software package and its output capabilities. I felt that in order to have full control over the effects and be able to design my own imagery I need to find a software with more expansive capabilities. Eventually, I discovered Useful Bytes Ltd., a very small lenticular software company based in the United States, from whom I bought a basic package. This also proved to

¹³⁰ Humaneyes Creative 3D software - <http://ga.humaneyes.com>

have limitations, but on corresponding with the designer and explaining what I was attempting to do he offered me a version of their industrial package at a very reduced rate, as it was a new departure and very 'buggy'. This could then be used for the interlacing element of the work.

I should point out at this stage that this is only a small part of the process when attempting to create a 3D glass lenticular, as of course I wasn't satisfied with creating 3D images from photographs of mugs and plant pots, so I began to learn how to design digital 3D forms in Rhino and Illustrator, which I could then capture images/viewpoints from, and take these into my interlacing software.

5.7. Casting Techniques Towards Lenticular Lens Production

As discussed, the commercial context for the production of lenticular lenses and corresponding imagery is highly developed and exact. For the purposes of this research, my initial aim to create an accurate lenticular lens in glass was further complicated by the physical properties of the materials and the necessity to produce this lens within a studio environment.

To ratify what was achievable, in terms of the precision obtained via a kiln formed process, I began working with samples of commercial, coarse, medium and fine acrylic lenses. These were Industry-standard lenses with the following specifications: 10 lenticules per inch, 20 lenticules per inch and 30 lenticules per inch. Practical restrictions in the working thickness of glass meant that acrylic industry 3D lenses of below 2mm in thickness were not attempted. So, my 10lpi, 20lpi and 30lpi lenses all needed to be at least 2mm thick to ensure that I could, in mimicking the acrylic versions, cold-work the glass pieces safely and accurately. In fact, the lenses that I selected all varied from 3mm to 1.9mm.

To collate samples of these lenses I contacted the American lenticular lens fabricator Pacur. This company has been manufacturing lenticular lenses and plastic sheet resin since 1992 and are world leaders in the field.¹³¹ Using a sample folder of Pacur lenses, I selected from these the specific lenses for testing.

The complexities of lens types and the accuracy needed to gain the correct viewing angle and focal point when attempting to produce a glass lens led me to consider new production techniques. These techniques, as explained below, were explored

¹³¹ 'Lenticular Print', *Pacur*, <https://www.pacur.com/markets/lenticular-print>, (on-line) [Accessed 28/04/19].

concurrently, due to time restraints and necessary waiting times, such as moulds drying and steaming, within each of the methods explored.

Vacuum Casting Glass

Having examined industry lenses, I realised that the formal aspects of the lens required a technique that could capture small detail accurately, in the case of the curve of the lens surface, and also capture a consistent thickness of the glass object produced to ensure a crisp focal point when viewing. In order to maintain both the top lens surface and the thickness I deduced that a 'closed mould' might be required. That is, a 'lost wax'¹³² glass casting process, to allow control of all aspects of the three-dimensional form.

This process in glass uses gravity in the kiln to run the molten glass into the cavity within the investment mould. Here the fluidity of the glass and elimination of possible air traps is fundamental. Glass does not have the viscosity to consume air, in its liquid state, within the material. As a result, air pockets in a casting mould will impede the glass flow into that section of the mould, creating great difficulty when attempting to cast very thin or narrow shapes.

Through my research I looked outside of conventional glass casting techniques to consider the metal casting version of this lost wax process. Instead of a gravity feed, this production method employs a vacuum to pull the molten metal, once it is poured, into the detail of the mould. This enables these metal pieces to be extremely intricate and thin. The vacuum casting of metal is a process predominantly adopted when reproducing small-scale pieces, in particular the translation of precious metals into jewellery objects; so is a technique that effectively navigates the casting of very fine forms. Interestingly, this practice is much quicker than the gravity-fed glass method, allowing the casting of forms to take place within seconds of the vacuum being activated. The vacuum method, as an industrial standard, also has a high commercial success rate in comparison to the gravity-fed glass process. Excited by the possibilities, I approached a small-scale metals casting foundry, Priory Castings Ltd, with whom I worked in collaboration for this aspect of the research.

To begin with, a cold silicon mould was taken from a sample acrylic lens. This allowed for a wax version of the lens to be poured and be put aside to set in a fridge.

¹³² Lost wax kiln casting is a versatile method for making glass pieces in almost any form imaginable. The process involves creating a refractory mould around a wax model. The wax is then removed—or 'lost'—creating a cavity. Glass is cast into the cavity, resulting in a fully sculptural finished piece. 'Lost Wax Kilncasting', *Bulls Eye Glass*, <https://www.bullseyeglass.com/methods-ideas/tipsheet-8-basic-lost-wax-kilncasting.html> [Accessed 1/04/19]

The wax was then attached, using a blow torch, to a casting sprig or tree with additional wax objects. See example below. (Figure 123).



Figure 123.
Shetara Edden Ring waxes setup on a wax tree ready for casting
Makers Row: Five Steps to Casting.
<https://makersrow.com/blog/2016/06/5-steps-to-jewelry-casting/>

The additional waxes, indicated here, were used to gauge the accuracy and detail of the casting in addition to the amount of pull the vacuum was able to achieve when casting in glass. These sprue¹³³ waxes were next fixed to a wax dome on a base board, to provide a reservoir once steamed out, and covered with the metal casting flask. (Figure.124).

¹³³ Sprues and runners are some of the largest pieces of excess material that we remove from moulded parts. They are created deliberately during the moulding process as the method in which the molten material enters the mould cavity. 'Sprues, flash and runners explained', *MRT Castings*
<https://blog.mrt-castings.co.uk/blog/sprues-flash-and-runners-explained>
[Accessed 1/04/19]

Figure 124.
Base board with wax reservoir (a) and casting flask in position (b)



Having fixed the tree of waxes to the wax base and secured plastic cottling¹³⁴ around the flask using elastic bands, string and clay, an investment mix of Crystalcast¹³⁵ was mixed. This mix was vacuumed, to remove air bubbles, and finally poured over the waxes in the flask. (Figure 125)



Figure 125.
Mould, post investment pour

Once set, the plastic cottling was removed and the mould steamed, to allow the wax to run out, for approximately two hours. It was then dried for three days and finally

¹³⁴ A plastic or vinyl sheet used as a barrier to encase liquid investment when mould making. Notably used in ceramic slip casting processes.

¹³⁵ Gold Star Crystalcast is a plaster-bonded investment powder specifically designed for casting glass. Produced by Goodwin Refractory Services Ltd (formally Goldstar Powders).

Exploring the Optical Perception of Image Within Glass

placed in a warming kiln ready for casting. In this casting process, prepared moulds need to be heated so that the casting material, in this case molten glass, remains fluid on contact with the mould surface. If the mould is not heated prior to casting, the molten glass or metal would almost instantly stop, due to chilling through contact with the cold surface.

In this metal working process, the viscosity of the casting material is crucial, and even more so when casting glass, so every effort has to be made to maintain its flow during casting in order to achieve the required detail and depth of pull into the casting flask.

Whilst the moulds were heated up in a kiln a crucible, or salamander, of glass was heated up in a furnace to a liquid state. (Figure 126). Again, this temperature is crucial in order to get the material to a fluid state, enabling it to be drawn into the mould via the vacuum.



Figure 126.
Furnace crucible or Salamander and the crucible being heated in the furnace



The warmed casting flasks are then taken out of the kiln using large metal tongs and slotted into the head of the vacuum chamber. (Figure 127).



Figure 127.
Industrial vacuum chamber
Priory Casting Ltd

Now a seal around the top of the flask is quickly created using fire putty, and the molten material is poured into the reservoir on the top of the mould. (Figure 128). On pouring, almost instantaneously the vacuum is switched on and, due to the porous nature of the dry mould material, the molten material is drawn or pulled down through the opening, via the vacuum, and into the mould cavity below. (Figure 129).



Figure 128.
Casting mould slotted into vacuum chamber and sealed with fire putty



Figure 129
Molten metal being drawn into the mould under vacuum

At this stage within the metal casting process, the metal-filled flasks are set aside and approximately thirty minutes later plunged into large troughs of cold water. (Figure 130)



Figure 130.
Vacuum cast moulds
being quenched in cold water in order to cool and de-mould the metal cast within

Of course, metal and glass are both materials that can transition from a liquid to a solid state but on cooling the similarities change, as the glass would shatter if rapidly cooled. The moulds omit steam due to the insulated heat of the metal and warmth of the investment and begin to disintegrate and dissolve. The metal casts are then removed from the flask, washed and ready for finishing. Glass, however, once

vacuum cast, then needs to be annealed,¹³⁶ to negate the internal stresses being created. So, the intact glass casting flask, once vacuum cast, is placed in a pre-heated kiln. The temperature within the kiln is evened out and then gradually cooled via an annealing cycle.

Having followed this casting procedure at Priory Castings prior to attempting a glass vacuum casting, it was necessary for me to have my own casting flask, flask tongs, salamander crucible and, to fabricate, a small-scale vacuum chamber. (Figure 131)



Figure 131.
Vacuum chamber
with pressure gauge, steel casting head and vacuum pump attached

As previously mentioned, the viscosity of the glass for this process is crucial, and determines the detail captured and depth of pull into the mould the vacuum can command. At this stage I was intrigued to test a range of glass types, to ascertain which chemical recipe would be most effective when using this technique. With this process the fluidity and heat held in order to create a continued flow is crucial: different glass compositions could therefore impact on this fluidity.

By creating my own set-up I was able to test different glass types, from specialist casting glasses to furnace glass. In order to achieve this, I used a smaller kiln to melt my glass batch, in a crucible and my larger kiln for the annealing stage of the

¹³⁶ Glass annealing is a controlled process of slowly cooling glass to relieve these internal stresses. Basics: Glass Annealing', *Kopp Glass*, <http://www.koppglass.com/blog/basics-glass-annealing/> [Accessed 5/4/19]

Exploring the Optical Perception of Image Within Glass

process. (See [Appendix II: F](#), for information on the process, firing schedules and results).

After testing it was clear that lead crystal, with its low liquid temperature and fluidity, was the most effective glass for this process, closely followed by Bullseye soda-lime glass. (Figure 132) Testing was carried out using Gaffer lead crystal, Bullseye soda-lime glass and Glasma furnace glass. The full results of this vacuum casting process can be found in [Appendices F](#).



De-moulding the castings

Glass castings on the casting tree



Original and cast glass version of the object, 4cm high x 2cm wide.

Figure 132.

Vacuum cast soda-lime glass tests

When examining initial castings using this vacuum process it was clear that the glass was filled with bubbles. On further research I realised that this was due to a lack of fining¹³⁷ within the glass melt process. I approached Richard Golding of Station Glass, who very kindly offered the following advice.

¹³⁷ The fining of glass involves the removal of gaseous inclusions. H.N. Mills, 'Use of Fining Agents', in: William J. Smothers, *Ceramic Engineering and Science Proceedings* (American Ceramic Society, 1986) <https://ceramics.onlinelibrary.wiley.com/doi/10.1002/9780470320327.ch7> [Accessed 25/09/18]

Most glass manufactures use antimony tri-oxide as the refining agent. This produces a lot of oxygen to be released at about 1200c and above. The oxygen then sweeps the other seed out of the glass (CO₂). Then as the glass cools to gathering temp the antimony re-absorbs the oxygen and the seeds disappear. Reheating the glass above 1,200°C will start the release of oxygen again, thus producing seed.

Once analysed, I started to test at what temperature the glass melt began to produce oxygen. By observing and documenting at what temperature bubbles became apparent in the melt I was able to lower the top melt temperature. This ensured I was able to produce a highly viscous glass but one which did not contain bubbles when being poured into the casting mould. This resulted in the subsequent castings being almost bubble free.

As mentioned in the introduction to this research, this lost wax vacuum glass casting process, despite being very effective and time-efficient, in comparison to the traditional gravity fed lost wax casting process, did not prove the most effective technique for producing accurate glass lenticular lenses. The narrowness of a lens, just 3mm thick evenly across a large surface, became unfeasible with this process. Here, within the studio environment, the vacuum capacity and mould size also limits the scale of the potential glass casting, and so whilst working on this aspect of my research I began to test other possible techniques to fabricate lenses.

Kiln formed Lenticular Lens Tests

[Chapter 5.4](#) discusses commercial lenticular lenses and the technical specifications which are particular to each lens type. As stated, my interest lay in creating a 3D lens, resulting in my decision to use 10lpi, 20lpi and 30lpi 3D acrylic lenses as my starting point. In parallel with research into the vacuum casting process I also began to take open Crystalcast investment moulds from these acrylic lenses. As accuracy was of paramount concern, the investment mix was prepared, as per the manufacturer's instructions, and vacuumed prior to pouring, to remove air bubbles. With initial small tests, once poured, the moulds were then placed into the chamber and once again vacuumed. Double vacuuming ensured that there were no bubbles present in the mix that could attach themselves to the acrylic form and create surface pimples on the final glass version. These moulds, once dry, were placed into the kiln and glass melted into them.

There were several issues with this process. The moulds had to be evenly dried to stop trapped moisture, in the form of steam, from creating eruptive cavities within the glass lenses. This I resolved by using a damp meter, testing the edge and back of the mould, to ensure an even dryness throughout.

The next issue was the quantity of glass. I began by weighing out glass calculated by measuring the area of the mould but noticed that this didn't always result in an evenly thick casting, despite the kiln shelves and mould being calibrated by a spirit level. This resulted in my moving away from cullet and using 3mm sheet glass. The sheets ensured that the glass was evenly distributed, and that the quantity of glass required was accurate.

Of course, this initial testing only resulted in a relatively consistent thickness across the glass piece and replication of the detail of the acrylic lens. In order for this glass lens to function as a lens the surface of the glass needed to be highly polished, negating any noticeable contact with the mould. Contact during the kiln forming process resulted in a dull, unpolished surface on the glass. This slightly matt surface rendered it useless as an optical lens, and due to the fineness and detail of the lenticules it wasn't a form that could be hand polished. Even if the lens had been made from a lead crystal glass, enabling it to be acid polished, I knew that the process of the acid biting into the surface of the glass could change the precise curvature of the lenticules, potentially making the lens uneven or flattening the angles. So, having created a mould and decided on a glass type, I now sought to develop a firing schedule that allowed the glass to sit into the mould, capturing sufficient detail without coming into contact with the investment. After extensive systematic testing, a perfect firing range was calculated and I began to test two types of 3D lenticular lens produced in glass for accuracy. (See [Appendix II: E1 – 9](#), for firing schedules and test results)

Lens testing was carried out using a laser light to assess the focal length of each lens. Very simply, by applying collimated light - that is, light which runs parallel - from the laser onto the surface of the lens and moving the lens back and forth, closer to and away from the light source, the distance at which the projected light can be seen becomes focused. When focused, the refracted light appears as a consistent white dot rather than appearing as a dot with an aura or haze of different-coloured light. Of course, with a standard concave or convex lens this process is sufficient to determine the focal point, but with a lenticular lens one must also consider the calibration of the lenticular image to that of the lens, enabling a perfect match. Here it was necessary to allow the lens to focus on the plane which the image occupies. Then, once it was possible to calibrate the size and width of strips of lenticular image, it was possible to

give the observer two complete distinct images, one to each eye, via the refraction of the lens.

Having realised the optimum focal distance of the lens from the image plane, I began to examine how to create lenticular images.

5.8. The Lenticular Image

Working in collaboration with Tribal 3D holographic and lenticular commercial print services, I was able to gain expert insight into the glass lenses I had produced. Initial testing looked unpromising, and only through playing with the lenses on a light box and moving the glass further away from one of their standard lenticular images did we make a breakthrough. Of course, glass as a material has a different refractive index to acrylic and it was this that was creating the massive mismatch between the lens and the image. Once the lens was moved a specified distance from the image and held exactly parallel, the lens started to work.

This was the start of a very steep learning curve for me in assessing the calibration of each lens and then creating a 3D image which could be cut into strips and calibrated to match the individual lens. Initially Tribal 3D very kindly took my 3D images and interlaced these to my specified calibration. But gradually, as I began to understand the complexities of this process, I was able to fabricate a masking technique in Photoshop which went some way towards producing lenticular images, although these were very basic. Finally, through online research I discovered the small lenticular software company Useful Byte (UB). They currently offer off-the-peg lenticular software for the amateur lenticular enthusiast, but this very basic software only allows for the printing of postcard-sized lenticular images, which then have to be meshed with standard 40lpi acrylic lenses. On approaching this company, they were really interested in my research and very kindly offered to sell me their professional software at a huge discount. This then allowed me to more accurately interlace 3D images created in Rhino 3D and/or Photoshop to bespoke calibrations which match my glass lenses. Hours of systematic testing resulted in the creation of images which appear three dimensional or animate when the glass lenticular lens is applied. (See [Appendix II: G](#) for the stages of lenticular image creation)

As mentioned, when researching the focal length of these glass lenses, these images, once they are created as digital ceramic transfers and applied onto or within the glass, have to be placed at the correct distance from the lens for the image and lens to mesh. Whilst designing pieces I was able to embed these into cast blocks at the correct focal distance.

Exploring the Optical Perception of Image Within Glass

In order to move away from the familiar edge to edge of the lenticular postcard I also started to explore the possibility of making works which were part lens and part flat glass-based, playing with lens shapes within the surface of the glass. Much the same as grinding out a polished lens within a block of glass, this had the effect of expanding the visual language possibilities and within that the ocular perplexity of the work.

Practically, the works created using glass lenticular lenses and purpose-designed 3D lenticular images proved complex. Multiple firings allowed for the gradual assembly of each element and a clear methodology to make these works within the studio was established. It should be said that although a basic fabrication method for these initial lenticular works was determined, each work thereafter presented new challenges.

6. The Work

As discussed within the technical section of this thesis, the resulting body of work has emerged gradually through continued systematic empirical testing. The combination of these practical discoveries and innovations, in conjunction with subjective observational examination, has formed the direction and to some extent the visual aesthetic of the pieces.

Although this research set out very clearly to explore how glass as a material could be used to challenge the optical perception of an image, with particular focus on psychological spatial reference, the formal and aesthetic language within this work has evolved an extension of this notion of 'space'. By examining how we relate to spaces, and how different responses can be attached to a given space or environment, personal schemata and preferences, which build upon my own artistic practice, were used in determining the visual semantics adopted.

For example, within the primary work, [Treeline](#), the imagery utilised to test the practical application of reverse perspective principles was taken from my own photographic library of landscape references.

Here it is important to once again note that throughout this project personal images have been taken up but for the purposes of this research question these only serve to exploit the optical cues under analysis, and within this context they are a subtext.

6.1. Creating a Foreground Plane

Observing a view through a window sets an image in a context and enables the framing of the scene. It creates an unseen foreground, a positioning of the viewer to look into the scene, whilst investigations into the soft focus, or [bokeh](#), of an image allow the artist to dictate the point of interest and draws the onlooker in. Drawing upon these strands of thought and working with my, image-led glass casting practice, as discussed in [Chapter 1.1](#), I began to test theories on the positioning of the viewer. (Figure 133.)



Figure 133.
Helen Slater Stokes *Focus* (2018)
Cast glass. 42 x 29 x 6cm

By adopting bokeh effects the peripheral vision of an image becomes muted, faint and diffused, and the visual focus is clearly defined. Interestingly, by guiding the spectator's focus and softening the outlying imagery one is also creating a framing of that point of interest and visually fabricating another solid plane on the surface of the glass, like the metaphorical pane of glass in front of the observer when looking out at a countryside view. This intriguing visual stratagem allows a suggestion of the complete scene. Through the partially softened graphic, the gathering of sufficient peripheral data ensures that the image is comprehended. Then, working as the eye might, a clear point of focus draws the reader in, past the frosted surface and into the image's depth. This simple manipulation of the previously glossy surface of the glass sets a marker for the outer edge of the viewing space, locating the observer outside of the scene and fabricating a frame or window which invites them to peer in. This very effective visual device is then enhanced by the layered versions of the pictorial scene within. These appear animated, allowing the comprehension of layers and depth. Finally, the slight magnification of the section of imagery under the highly polished focal point draws the spectator in to what is perceived as a three-dimensional scene.

6.2. Exploiting Perspective

The term 'reverse perspective' has been widely used by scholars, notably when describing Christian iconography from the 3rd century AD onwards.

...throughout the history of Christian icon painting, several recurrent features indicate a tendency of reversing the rules of linear perspective rather than ignoring them. This unconventional rendering technique directly questions the unique viewpoint principle and is manifested by supposedly parallel lines converging towards the viewer, instead of converging towards a vanishing point at infinity away from the viewer.¹³⁸



Figure 134.
Andrei Rublev *Annunciation* (1405)
Tempera on Wood. 81 x 60cm
The Cathedral of the Annunciation, Moscow

This approach of reversing what we would now recognise as the conventions of pictorial perspective is illustrated in Figure 134. In this work by Andrei Rublev (1360–1430), entitled *Annunciation* and painted in 1405, the Western viewpoint principle is questioned, as parallel lines within the work converge towards the viewer, as opposed to a virtual vanishing point at infinite distance from the viewer.

¹³⁸ Theodor, 'Reverse Perspective in Christian Iconography', *The Peacocks Tail: Essays on Mathematics and Culture* [blog] (April 27th 2011), <https://pavlopoulos.wordpress.com/2011/04/27/reverse-perspective-in-christian-iconography/>, Online, [Accessed 10/08/19].

Geometrically the viewer is placed at the centre of a vanishing point which, instead of receding into infinity within the composition, supersedes the pictorial plane pointing out towards the observer. This take on the onlookers' position within the composition also owes something to Euclid's 'Optics' (c. 300 B.C.), one of the first writings bringing mathematics and visual perception together. In this text, Euclid acknowledges that, due to our binocular vision, when viewing a cube, for instance, we gather two images and combine these, technically allowing us to see more than half of that form.¹³⁹ This contradicts the principles of linear perspective originated by Leon Battista Alberti in the 15th century, but perhaps this approach speaks more to the religious subject and its priority in these works or the simple need for the artist to create a pleasing composition, despite its now obvious inaccuracies.

This notion of the positioning and interaction with the observer is intriguing when discussing perception; perhaps this non-conventional take on perspective is intentional.

The two works created during this research which address ideas of reverse perspective, [Geometric Perspective](#) (Figure 112) and [Treeline](#) (Figure 135), rely on the viewer's understanding of the familiar perspectival construct. Here, as in the early Christian iconographic works, the vanishing point has moved. Consistency, within this contradiction of Western perspective, positions the spectator within the rendered space, rather than allowing them to be an onlooker peering into the pictorial plane. To add to the illusion, the cognitive assessment of what we are seeing is confused by the visual paradox created. For an example of this, click the link below Figure 135 to see a video which illustrates how this optical contradiction is created in the piece entitled *Treeline*.

¹³⁹ Translation by Harry Edwin Burton, The Optics of Euclid, Journal of the Optical Society of America, May 1943. <http://philomatica.org/wp-content/uploads/2013/01/Optics-of-Euclid.pdf> p362.[Accessed 20/12/18]

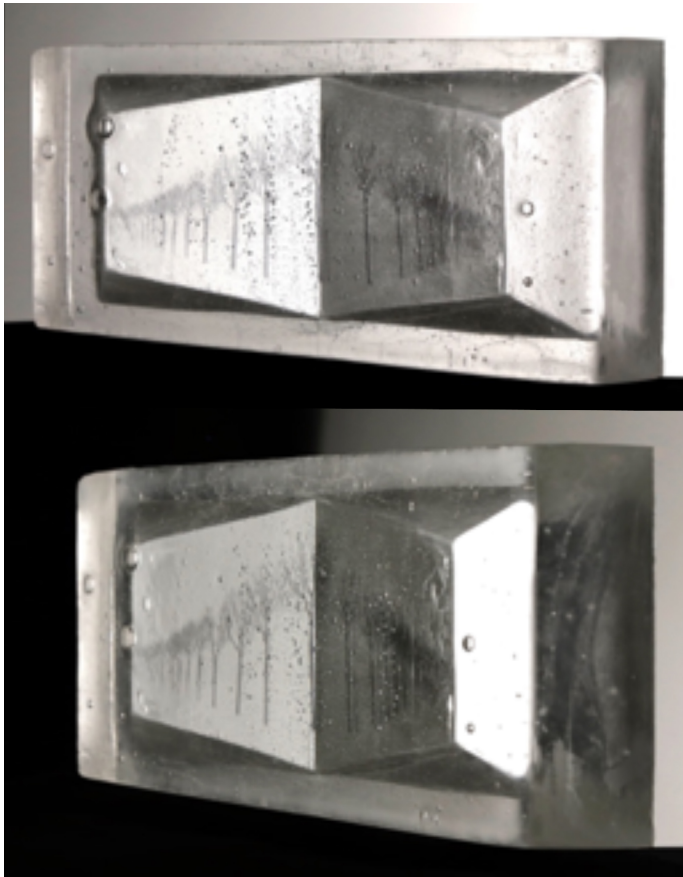

Figure 135.
Helen Slater Stokes *Treeline* (2016)
Cast glass and ceramic transfer. 48.5 x 25.5 x 11 cm

<https://vimeo.com/user26710662/treeline>

Although effective at a given viewing angle, like the Patrick Hughes paintings which work on the same principle, the flip between understanding the pictorial image, and then not, is momentary. While intriguing, further work is needed with this approach to image perception in order to replicate a convincing initial view. Image complexity must be enhanced, as in [Hughes' paintings](#), in order for a subtle drawing-in of the viewer to take place. Only when totally immersed and convinced by the scene can the impossibility of its comprehension come into play.

Overall, although effective at the point of paradox, these pieces still need work in order to hide the practical mechanism of this illusion. Forms evident in the internal casting need to be further refined and seamlessly incorporated in order to create a convincing visual subterfuge. These works allow the viewer to initially assume a perceived understanding of the image within. Here it is not a short step to confusion, as happens in a work by [Escher](#), as the image itself only gradually gives up its incomprehensible logic when analysed.

To perplex the observer, the image needs interaction: that is, the piece or the viewer must move and interact in order for the illusion to occur. Again, the role of the

observer, and their cognitive perception and interaction, is crucial in effecting a change in how the image within the glass is perceived. This methodology is conceptually and optically thought provoking and something which I plan to explore further.

6.3. Lenticular Artworks

Parallel to the practical testing of reverse perspective principles, I began exploring lenticular possibilities. This was a much more extensive element of my research and one which prompted the necessity for a steep learning curve, in both my glass fabrication techniques and computer design knowledge and skills.

Technical methodologies had to be refined through iterative studio experimentation and a tacit understanding of the material, gained from experiential knowledge, in order to create an accurate marriage between image and lens. As touched upon previously, the use of geometric forms enabled the testing of lenticular techniques by employing recognisable shapes. These were able to exploit our intrinsic cognitive understanding of three-dimensional space and allow analysis of the effectiveness of the illusion without the necessity for a more conceptual approach.

Spheres created in Rhino 3D software and rendered as virtual solid forms permitted the interplay of three dimensions and spatial positioning, through scale reference and by adopting interposition or overlapping principles. (Figure 136)

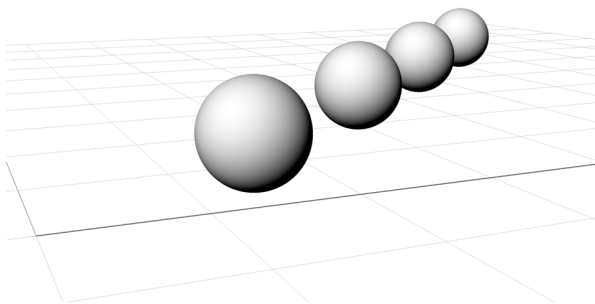

Figure 136.
Spheres rendered in Rhino 3D software

Next, these designs were digitally interlaced to match with the glass lenticular lenses. (Figure 137) See [Chapter 5.6](#) for details on the interlacing process.

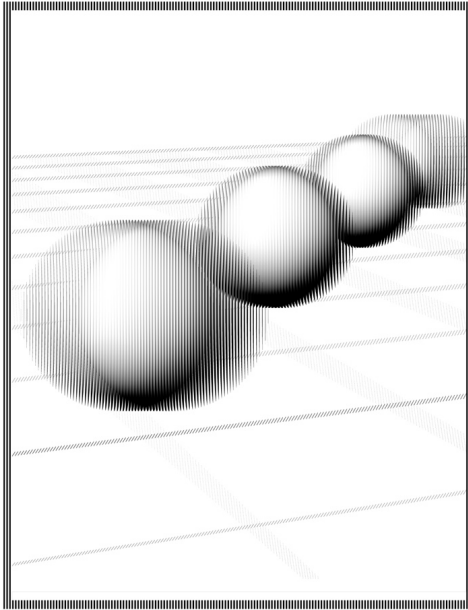

Figure 137.
Spheres image after digital interlacing
dimensions 28 x 21cm

Interestingly, due to the process used in creating the interlaced image involving the repeat of formal information across the lens, these spheres not only appear to be three dimensional but also appear to visually bounce or roll when the viewer moves past. (See Figure 138)



Figure 138.
Helen Slater Stokes *Oculus*
Kiln formed glass, ceramic transfer, Hxtal. 27 x 24 x 5cm.
Photography by Ester Segarra.

Here is a link to a video of the optical effect created by Oculus

<https://vimeo.com/385790490>

Exploring the Optical Perception of Image Within Glass

The second work in this series was developed by exploiting what happens if a lens is mis-matched to an image. With the lens applied at 15-degrees from vertical (lenticulars rather than being vertical run to one o'clock, if viewed as a clock face) to the image, the spheres now become cog- or blade-like, as the registry is broken. (Figure 139)



Figure 139.
Helen Slater Stokes *Acuity*
Kiln formed glass Ceramic transfer, Hxtal. 27 x 24 x 6cm

Follow this link to see a video of the optical effect created by *Acuity*:

<https://vimeo.com/385789725>

Now, as the observer interacts with the work, instead of rolling, the shapes within the glass start to spin. What I enjoyed most about showing these pieces was the audience reaction. Whilst passing the works, within their peripheral vision viewers caught a glimpse of the animated forms. This caused them to do a double-take. Once noticed, the animated qualities in the works captivated them, forcing them to adopt a rocking dance in front of the piece. The side-to-side motion was closely followed by peering around the work, in an attempt to figure out where the image was located spatially and how this effect was achieved.

Again, these glass lenticular pieces focus predominantly on the principles of binocular disparity in perceiving three-dimensional depth. But it is crucial to note that this is an oversimplified way of looking at how our complex brain works in calculating

distance or depth. Monocular cues, like relative distance and other cognitive schemata, play a role but scientists are still discovering new processes in the brain.

For example, on discussing these works with the viewing public I was interested to discover that one particular viewer had only one functioning eye - the other was a very convincing replica. On further questioning she explained that, after losing her left eye in an accident, it had taken her brain only a few months to adapt. Although she wasn't aware of how she was now able to comprehend depth, it was clear that she understood exactly what the work was doing visually and interpreted the different notions of perceived depth involved. I considered the possibility that through her movement the gathered images, as with binocular vision, were processed by the brain and their disparity assessed to establish depth perception. On further reading, my layperson's knowledge of visual depth perception, although acceptable, proved limiting. There is no doubt that the brain can adapt to enable it to rationalise the data taken in by the eyes.

Research suggests that the individual can adapt to a new set of visual stimulus cues that deviate considerably from those previously learned. Experiments have been carried out with people who have been given spectacles that reverse the right-left or up-down dimensions of images. At first the subjects become disoriented, but, after wearing the distorting glasses for a considerable period of time, they learn to cope with space correctly by reorienting to the environment until objects are perceived as right side up again. The process changes direction when the spectacles are removed. At first the basic visual dimensions appear reversed to the subject but within a short time another adaptation occurs and the subject reorients to the earlier, well learned, normal visual cues and perceives the environment as normal once more.¹⁴⁰

Recent research into monocular spatial perception, by a team led by Greg DeAngelis from the University of Rochester, suggests that, motion is indeed involved, but this is seemingly based in the ears, within the vestibular system of the inner canal. This fluid-based system is linked to the brain, telling us whether we are in motion or still,

¹⁴⁰ Louise Jolyon West, Kai V. J. von Fieandt, et al, 'Visual Factors in Space Perception', *Encyclopedia Britannica*, (May 2017)
<https://www.britannica.com/science/space-perception/Visual-factors-in-space-perception> [Accessed 10/09/19]

and how we are positioned in relation to gravity. As Steven Novella, in his 2008 article *Monocular Depth Perception*, states.

What DeAngelis and his colleagues have discovered is a brain region (the middle temporal region) that combines visual information and vestibular information to produce an independent estimate of distance. The brain is combining parallax from the visual system with an estimate of how much we or our heads move or rotates from the vestibular system - movement and parallax = distance.¹⁴¹

That said, I later spoke to a fellow researcher who also had lost an eye, and he thought that he had developed a slight tick or twitch, enabling him to gather two images, via his good eye, for the brain to use to create ocular disparity and so calculate visual depth.

What is certain is that we are still discovering exactly how the brain functions in constructing a convincing image of our surroundings.

After testing with simple sphere designs, I began to develop more complex designs, based on landscape. These challenged my ability to create virtual three-dimensional spaces digitally and offered different conceptual possibilities. The landscape imagery allowed for a different type of recognisable form, a figurative reference rather than a geometric or abstract one. Here, the employment of cognitive references for relative scale and the textural gradient of recognised forms suggested a greater spatial illusion within the composition, even before lenticular conversion. (Figure 140.)

¹⁴¹ Steven Novella, 'Monocular Depth Perception' (March 2008) <https://theness.com/neurologicablog/index.php/monocular-depth-perception/> [Accessed 25/08/2019]



Figure 140.
Landscape pen drawing



Figure 141.
Digitally interlaced version of this
landscape composition
30 x 21 cm

In the drawing above (Figure 140) the tree that is closest to the viewer appears larger than those in the distance, and there is much more detail on this tree than those depicted as across the field, which are made up of much more gestural marks. Simply, through the drawn mark and composition, the image suggests a familiar spatial depth. The exploitation of these optical cues when combined with lenticular interlacing adds a further dimension, as the reader perceives the movement of the foreground tree. See the digitally interlaced image of this drawing in Figure 141; an Mp4 of how this work functions optically can be seen using the link below:

<https://vimeo.com/385792065>

Now, on viewing, you are able to look around the tree, which appears to be located in front of the rest of the image. When moving from the centre to the extreme edges of the work, one appears to be able to see further down the field behind and into the distance.

This work was a real turning point in terms of the realisation that, with supplementary development, figurative renderings of a virtual three-dimensional space were possible and effective. And I was delighted that, when showing this work for the first time at the RCA show 2019, it was purchased by the co-owner and designer of Rockstar Games, a company dedicated to digitally realising a virtual three-dimensional world.

6.4. More than the Sum of the Two Parts

At this stage I took time to reflect on the works so far and concluded two things. Firstly, I felt there was a need to move away from the edge-to-edge lens. Although created in glass, there was a danger that the works could be trivialised by their association with the novelty postcard references that most people think of in relation to lenticular imagery. As I was able to create the lens in any shape or size, could I also create the lens at any point on the surface of the glass? This would then add further spatial ambiguity and optical confusion and would enable sections of work to be transparent and static, whilst others were prompted to become more three-dimensional and animated.

Secondly, if trying to convey additional depth within a work, why make pieces that had a depth? Why not make very thin works that once again added to the reader's miscomprehension of what was visualised?

The resulting works, part of the *Grid Drawing* series, enabled a central circular lens within a square form to be used, with the pieces taking on a total thickness of only 6mm. (Figure 142)

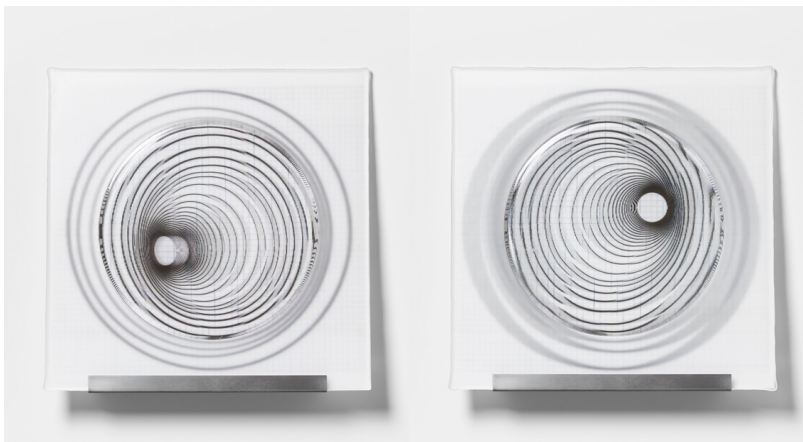

Figure 142
Grid Series: Asymmetric Cone and Asymmetric Vortex (2019)
Kiln formed glass, ceramic transfer, stainless steel. 41 x 41 x 6.5cm.
Photography by Alick Cotterill.

In addition to this I decided these would not be hung on the wall but be leaned against it, whilst sitting on a ledge. By doing this I felt the series moved away from the tradition of pictorial wall-hung art, allowing them to sit between hung images and three-dimensional works. It was also important, in stepping away from the pictorial, that each piece began to allude to its simple integral parts. The works were made up of a metal ledge and two pieces of glass. Here the frontal glass element includes the central circular lens and the rear glass houses the lenticular image. I enjoyed the simplicity of this system of two parts aligned on a ledge. These pieces were able to

Exploring the Optical Perception of Image Within Glass

convey that the sum of the two parts created a whole, with neither element able to convey depth without the other. They clarified the visual sensory experience, as each part could be examined independently, with the work only coming to life the instant the two pieces interacted. Materially the two elements, lens and image, become one and the manifestation of the image sits within the perception of the onlooker, producing an interactive virtual form. This reference to an almost holographic expression enables a change in the creative dialogue that an image in glass holds.

Visually this series addresses two compositions, asymmetric concentric circles and symmetric concentric circles. (Figures 143 and 144)

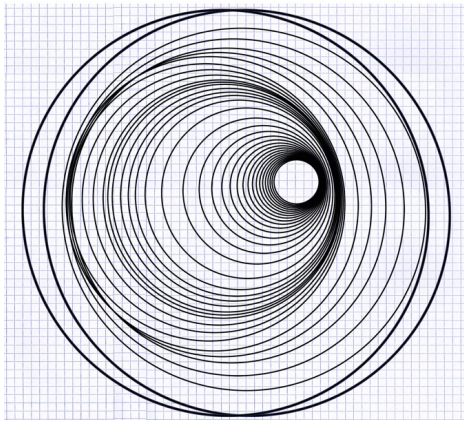

Figure 143.
Asymmetric design
41 x 41cm

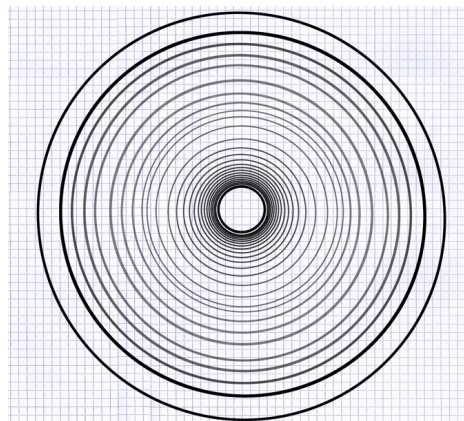

Figure 144.
Symmetric design
41 x 41cm

Of course, these elementary compositions can be viewed in opposing ways, seen either as circles receding, creating a tunnel effect, or as circles moving forward, building a cone-like form. Designed in such a way that these opposing visual interpretations could be applied, they were created in digital three-dimensional space, as receding or protruding forms, and converted into lenticular images.

As you can see from the link under Figure 145, with the tunnel, or *Vortex*, versions of the composition the outer rings spin and animate whilst the plane central circle remains static.

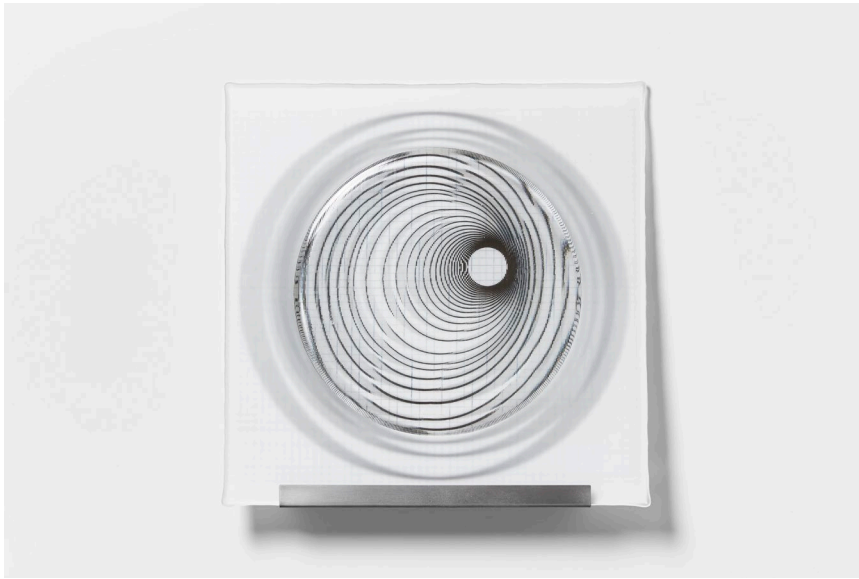

Figure 145.
Helen Slater Stokes *Asymmetric Vortex* (2019)
Kiln formed glass, ceramic transfer and steel. 41 x 41 x 6cm Photography by Alick Cotterill

This motion draws the viewer in, as the walls of the tunnel almost ripple and pulsate when the viewer moves around the work. It is notable, when watching how this work animates, that like the spheres the images trip slightly as it repeats, creating a wave of movement. Also, the application of a frosted surface surrounding the lens, as in previously discussed works, fabricates an additional visual plane within the composition, asking the viewer to look past this outer surface and into the pool of the polished lens. This satin surface orchestrates the diffusion of the lenticular image behind, suggesting there is more below the surface whilst alluding to the two-dimensional nature of the flat image behind

Asymmetric Cone, the formal reverse of *Asymmetric Vortex*, acts in a similar way. See Figure 146 and follow the link to view an mp4 of how this piece works optically. In this work the central circle is highly animated, as it is perceived to protrude out of the glass's surface, and the outer rings are animated less the larger they become. This optical disparity is what causes the animation of the central circle, like the rolling spheres in 'Oculus'.

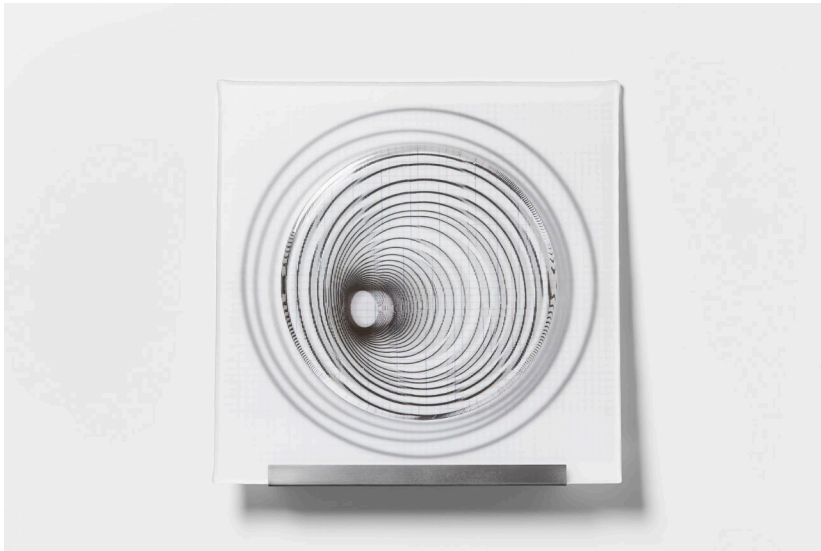

Figure 146.
Helen Slater Stokes *Asymmetric Cone* (2019)
Kiln formed glass, ceramic transfer and steel. 41 x 41 x 6cm
Photography by Alick Cotterill

<https://vimeo.com/382436134>

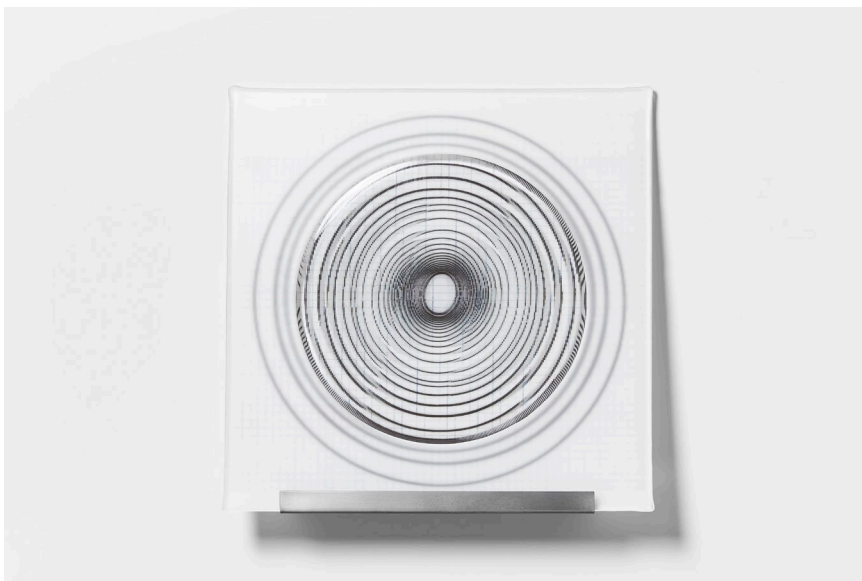

Figure 147
Helen Slater Stokes *Symmetric Cone* (2019)
Kiln formed glass, ceramic transfer and steel. 41 x 41 x 6cm
Photography by Alick Cotterill

<https://vimeo.com/382430300>

Within this series I also designed a symmetrical version, which begins to perceptively curve the face of the surface of the glass. A link to view the visual effect is underneath Figure 147.

The final work I wish to discuss is a piece entitled *Breaking Ground*. (Figure 148). This work started a discourse around subjects addressed within my glass practice and geometric spatial references explored within the research-based *Grid* series

Exploring the Optical Perception of Image Within Glass

mentioned above. Here I wanted to use notions of an emotive landscape, which I regularly work with. These are spaces or places that no longer exist, as I remember them from childhood. Fields and woodlands that have been re-purposed, built upon, felled, impacted by human development. I was interested in merging this poetic pictorial reference, which I adopted in the piece entitled *Virtual Landscape*, with the sterile and mathematical notion of space, the concern of works in the *Grid* series in an attempt to communicate the two differing perspectives on a given space, those of the emotive and those of the quantifiable.



Figure 148
Helen Slater Stokes *Breaking Ground* (2019)
Kiln formed glass, ceramic transfer and steel. 47 x 38 x 6.5cm
Photography by Alick Cotterill

<https://vimeo.com/372678157>

In this work the perspectival coloured frames float out of the piece and create a semi-automated mapping of the depth across the field. The diffused landscape image holds a wistful melancholy notion of a place which gradually fades away as the bright, sharp planes settle within the field. See the link below Figure 148 to view how this piece functions optically. Whilst working on this idea I also started to look into creating a lenticular animation that followed the viewer across a ploughed field, playfully skipping along as it plots the posts laid out to measure the space for a building project. This is something that is currently in development but I am hopeful that a gradual fading in and out of the animated lenticular image, in combination with the more historic and emotive reference to place will lead to a poetic combination of both a minimal geometric aesthetic and personal nostalgia.

7. Conclusion

In conclusion I would like to return to the aims of this project as discussed in [Chapter 1.2](#) and compare these with the results achieved, after which aspects or areas of further research will be discussed.

The key aims were as follows:

- To analyse the mechanics of visual perception, data intake and processing, in order to gain a further understanding of optical perception.
- To investigate contemporary and historical visual techniques which use the image to create three-dimensional spatial illusions, and then to explore and extend their application in glass.

Practical aims:

- Development of a glass process to fabricate a lenticular lens, based within a studio glass environment.
- Development of a process to create and calibrate an image to this glass lens, which allows the viewer to perceive a greater spatial reference within this image when both lens and image are combined.
- To use the creative aims of the research to provide a context for further testing and the development of glasswork which pushes the perceived visual capabilities of the image combined with glass, facilitating an expansion of the perceived depth and three-dimensional intensity of the image.

Firstly, an analysis of the mechanics of visual perception, data intake and processing took place in order to gain a further understanding of optical perception. As discussed in [Chapter 2](#), an accepted understanding of optical visual perception has been conveyed within this project, but wider research within the specialist fields of medicine, biology and neuroscience is still needed to holistically comprehend our sensory perception of spatial depth, the development of which I am keen to follow.

Next was an investigation into contemporary and historical visual techniques which use the image to create three-dimensional spatial illusions. This was carried out using a wide range of resources and, although selective, allowed for a synopsis of the

development of the mimetic and illusionistic image in Western art. By contextualising the research within historical and contemporary image-rendering techniques, this project has benefited from a full understanding of these visual practices, in particular how they employ optical and cognitive cues in order to produce a convincing, comprehensible depth image. (See [Chapters 2.3 to 2.6](#))

This starting point was then expanded to produce imagery that does more than simply illustrate a sense of space. This image, when combined with a glass lens, is perceived to supersede the surface of the object or deeply recede into a fabricated space greater than the depth of the form which contains it. Here glass acts as a facilitator, a catalyst, in transforming the pictorial two-dimensional into the perceived three-dimensional. The glass lens is now the active agent in enabling the perceived transition of the image from two to three dimensions. A virtual sense of space and time is also fabricated, as the image animates and changes, in harmony with the viewer's movement around the work.

As noted in the practical aims, the technical research spans both the production of the glass lenticular lens and the creation of a lenticular image which meshes exactly to this glass lens.

The successful manufacture of an original, accurate 20lpi 3D lens in glass, using studio-based kiln-forming techniques, was achieved via extensive practical empirical testing. A range of possible lenses were surveyed, and although seemingly accurate these lenses, when tested using an industry standard lenticular calibration sheet (see [Appendix II: E6](#)), appeared blurred, distorted and non-functioning. Here the refractive index of the glass was key. It was only when this was realised that testing could continue to ensure that the focal point for the lens was measured and the image fixed strictly at that distance from the lens to enable the confluence of each element.

The establishment of a precise lens enabled the development of a methodology for creating an image which was exactly calibrated to the lens. As explained in [Chapter 6.3](#), the production of the image as a three-dimensional composition in Rhino 3D Software and then its translation into Adobe Illustrator and Photoshop enabled the final file to be digitally interlaced using the Power Illusion software. The model for this translation process, from initial image to its final lenticular form, was developed by firstly drawing on prior research into pictorial optical cues. This knowledge, in addition to the extensive ocular testing of the digital three-dimensional form once interlaced, allowed for the distillation of each image. At this stage, specific lenses were allocated to particular images and the images recalibrated to individually

match each distinctive lens, generating a crisp, credible, mesmeric, animation of the three-dimensional composition.

A by-product of the initial practical testing to produce an accurate lens, was the realisation of a technique to vacuum cast glass within the studio environment. (See [Chapter 5.7](#)) Although this process was not adopted for the production of final works, within this research, it is none the less a methodology which allows for the lost wax casting of glass under vacuum, within the studio glass context. This process facilitates the creation of a detailed lost wax glass casting via a substantially quicker and more reliable procedure than the gravity fed method. Casting are quickly filled under vacuum, removing any possible air traps and then annealed in the kiln. The only limitation at this stage is the scale of works produced. Casting flasks range in size up to approx. 22 cm in depth, by 15 cm wide and the draw applied via the vacuum pump is determined by the machine's specification. Despite restrictions, this is a process that I will continue to use and explore within my own studio practice and one which is perfect for small to medium scale detailed lost wax glass castings and for digitally printed waxes.

This practical research to mesh image and glass lens creates synergies across the two separate fields of kiln formed glass and commercial lenticular image production. By achieving the final aim, to develop a process to produce glass lenticular lenses and an image that is accurately calibrated to that lens, a new three-dimensional visual language for the image behind or within glass has been realised.

It is important to note that all of this research has been carried out within the parameters of a studio glass practice, [as examined in Chapter 1.3](#), and as such it offers new methodologies and technical approaches in glass production to this community. In addition, it also begins to consider the perceived spatial reference within a two-dimensional image in glass as an experience, an entity in its own right, which is generated by the two separate elements of the lens and the image. Within this project, glass, as an analogue component, has become more than a viewing screen between spaces. This image is no longer a static rendering but an active and experiential entity.

This research project has empowered me to create a new body of work which expands and builds upon the spatial concerns I had previously addressed in my practice. It has enabled me to focus on the conceptual references and theoretical approaches I adopt and allowed me to reflect on my practice as a studio-based glass maker.

Interestingly, what has become apparent through this research is that we are a society which is almost totally visually orientated. This visual predilection has led to new technological and scientific developments orchestrated around this sense, perhaps to the detriment of others. We are drawn to the visual as it is the most dominant of our senses in the modern world. The seductive image has always been enticing, but as technology rapidly moves forward, led by a response to our sensual obsession with the visual, this notion of the image is now tied to a spatial reference. A new virtual reality, or augmented reality,¹⁴² has been created where the image can do more than momentarily whisk us away to another world, as it would perhaps in a painting. The ocular image is now interlaced with issues of space, time and physical interaction, opening up new artistic horizons and sensual realities.

7.1. Contribution to the Advancement of Knowledge

As this is a project that has been based within the glass studio, the methodologies and strategies that have resulted are beneficial to the wider glass community. It presents a new visual language for the image, creating a synergy between glass as a viewing mechanism and the image. Here we observe more than a rendering of an image behind the glass. When encountering these works the viewer perceives the appearance of a new image which transcends the two-dimensional plane into the virtual. Materially the two elements, lens and image become one and the manifestation of the image sits within the perception of the onlooker, producing an interactive virtual form. This reference to an almost holographic expression enables a change in the creative dialogue that an image in glass holds.

Crucially, technical research within this study spans both the production of the glass lenticular lens and creation of a lenticular image which meshes exactly to the glass lens. It creates synergies across these two fields which had previously been separate.

The key contributions to knowledge are numerous and include the development of a studio-based glass vacuum casting process, for lost wax casting, and the production of an accurate glass lenticular 3D lens which meets a 20 lenticules per inch industry standard.

It should be noted that the vacuum casting technique, which was developed as part of this research, proved to be impractical in the production of lenses. Nonetheless, it offers a substantially quicker and more accurate technique for this type of casting

¹⁴² 'Augmented reality' – The result of using technology to superimpose information — sounds, images and text — on the world we see. Jesse Emspak, 'What is augmented reality?', *Live Science* (June 2018). <https://www.livescience.com/34843-augmented-reality.html> [Accessed 10/11/19]

within a kiln formed studio glass practice and, as such, is still relevant in contributing to knowledge in this specialist field.

Within the context of commercial lenticular lens manufacture, an accurate glass 20lpi lens does not scratch as easily as acrylic or resin versions, is not affected by UV deterioration and offers structurally architectural and three-dimensional applications.

Testing with float glass approved by the Royal Institute of British Architects (RIBA) has also proved successful, giving the project a relevance within this specialist context. This is something that I plan to explore further, in response to interest shown by the architectural and engineering firm Foster and Partners, in developing glass effects that can offer decorative optical solutions for builds.

With regard to the creation of a lenticular image calibrated to the glass lens, this research approach holds potential for lenticular printers who need a lens which avoids the issues with resin lenses mentioned above. It also offers a solution to those working with artists to create limited edition artworks. Here the production of a lens in glass, rather than resin, raises the perceived 'integrity' and value of a work, elevating the artwork through the use of quality constituents, as perceived within our subconscious hierarchy of materials.

In summary, findings within this research contribute to knowledge centres within the glass studio, in particular within kiln formed glass practices, with regard to providing a new visual language for the image when combined with glass.

The project also offers industrial potential: in particular for the commercial lenticular print community in their attempt to heighten the perception of lenticular imagery within the materially conscious art world. Lenticular lens producers could also consider glass when designing for specific jobs which require UV resistance and structural strength. And finally, as has already been mentioned, there is further potential if the process is scaled up industrially, to installation-based artworks and relevant architectural build applications.

7.2. Areas for Further Development

The development of technical processes and design decisions, based on observational analysis of the outcomes, has been an ongoing process throughout this research. These will continue in this way in my own practice.

Key areas for further development within my practice involve addressing the scale of the lens and image. The area of most interest would be the industrial scaling of elements of this project for architectural and art installation-based applications. This

will involve industrial collaboration, something which, as previously mentioned, I have begun to explore in particular the ability, on large sheets of float glass, to position lenses creating visual transitions from transparent clarity to lensed distortion or perceived three-dimensional imagery. Architecturally this could be adopted to hide visual eyesores, incorporate new interest within plain office views, or to introduce a decorative motif or animation on a building, or to aid signage and wayfinding. The selective positioning of imagery or distortion, imposed onto a view, creates an augmented reality, one that appears subjectively for the individual, transforming and animating as they visually interact with the plane. Site-specific art installation is another area of interest, allowing the expansion of this research into augmented realities which question the observer's ability to distinguish between what is physically present and what is illusory.

I am excited by the prospect of once again working with Tribal 3D Ltd, on scaling up the interlaced image, both in physical scale and file size, to achieve clear resolution and accuracy on a larger scale. Also, with the creation of the image in mind, I have been working, and will continue to work, on a three-dimensional animated image: one which appears and disappears following the observer across the surface of the glass as they walk by. This is something that I have, up until now, struggled with, but hope to resolve over the coming year. The requirements of this new and specific lenticular lens type necessitate a very accurate lens and image alignment in order to avoid the ghosting of images. Artistically I feel this offers great possibilities, on all scales, with regard to the creation of work which is interactive and visually poetic.

During this project I have gained the necessary knowledge, both practical, technical and theoretical, to continue an informed investigation into lenticular imagery and glass lens production, and I am excited by the future possibilities that this research has generated.

Appendices

Appendix 1: Plates

These are images of the works produced as part of this research which have been shown at the Royal College of Art in their Work in Progress Show 2018, the Royal College of Art Graduation Show 2019, the British Glass Biennale 2019 and Decorex 2019.

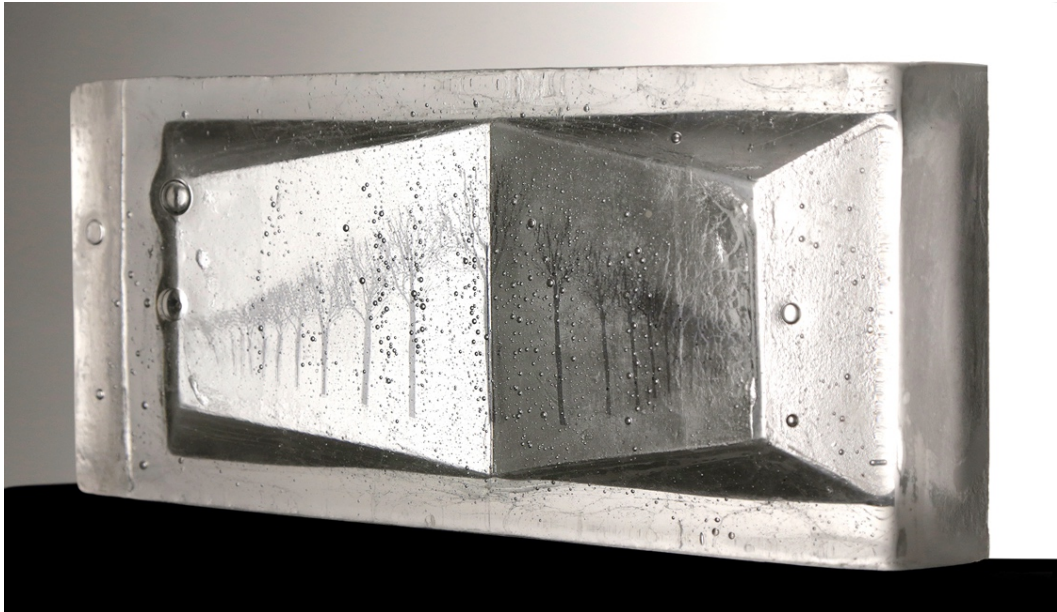

Plate 1.
Helen Slater Stokes Treeline (2016)
Cast glass and ceramic transfer. 48.5 x 25.5 x 11cm

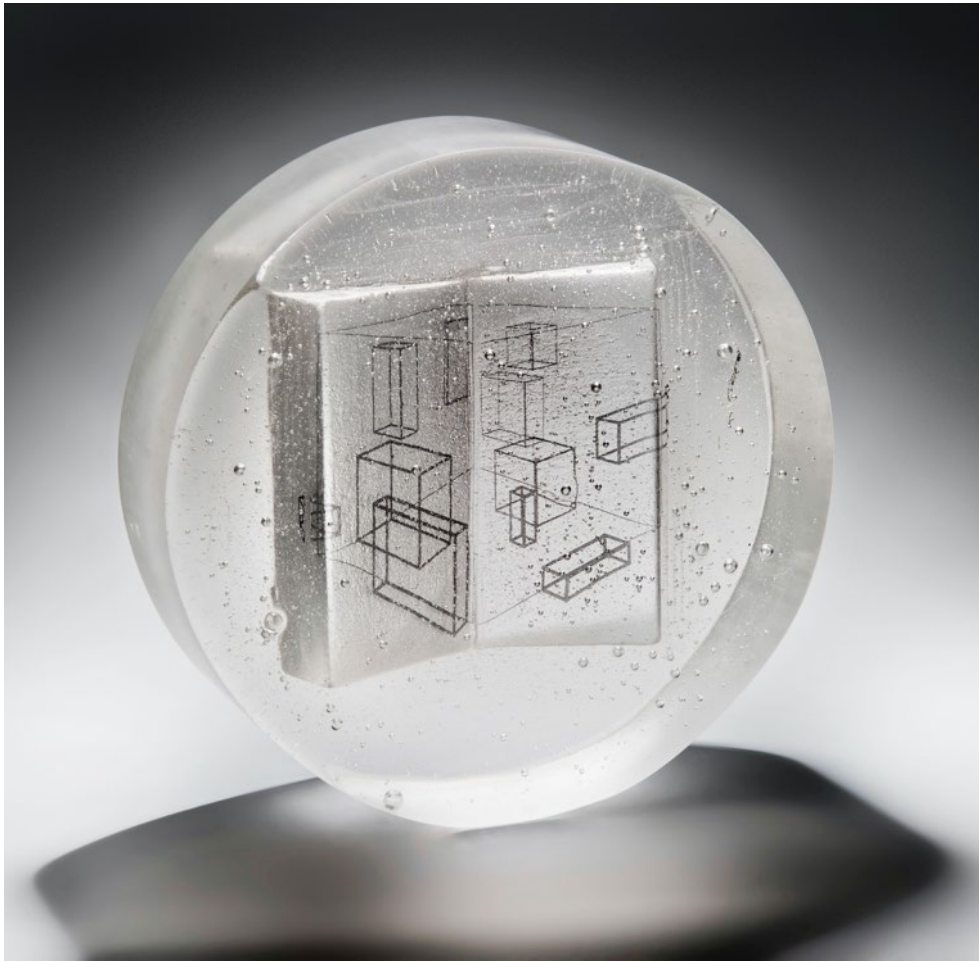

Plate 2.
Helen Slater Stokes *Geometric Perspective* (2017)
Cast glass and ceramic transfer. 42cm diameter x 12cm Photography by Ester Segarra



Plate 3.
Helen Slater Stokes *Focus* (2018)
Cast glass and enamel 42 x 29 x 6cm
Photography by Helen Slater Stokes

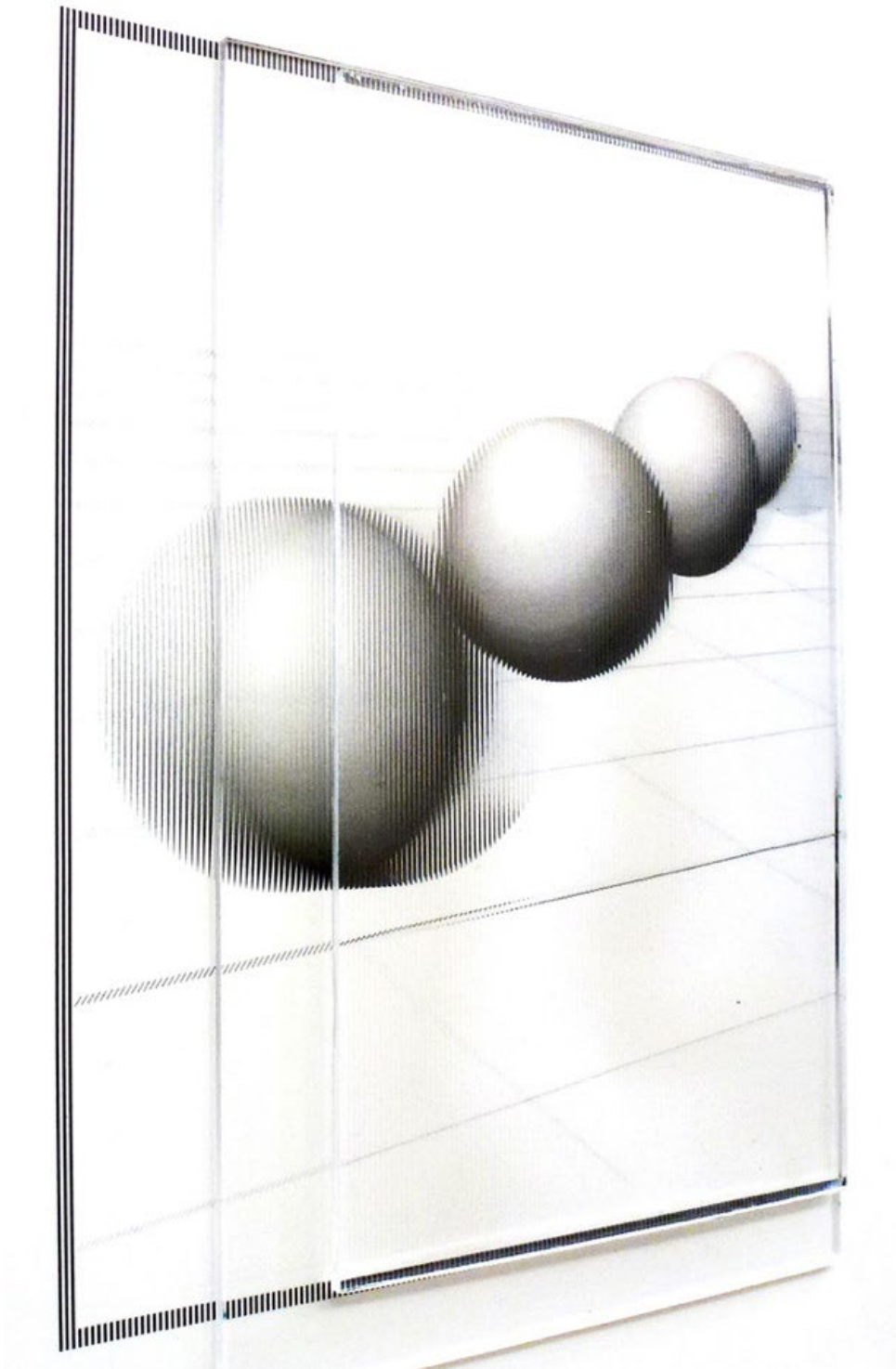

Plate 4.
Helen Slater Stokes *Spheres I* (2015)
Kiln formed glass and paper. 30 x 21 x 0.3cm
Photography by Helen Slater Stokes



Plate 5.
Helen Slater Stokes *Virtual Landscape* (2018)
Kiln formed glass and ceramic transfer. 29 x 24 x 5cm
Photography by Ester Segarra.



Plate 6.
Helen Slater Stokes *Blueprint* (2018)
Kiln formed glass and ceramic transfer. 29 x 24 x 5cm
Photography by Ester Segarra



Plate 7.
Helen Slater Stokes *Oculus* (2018)
Kiln formed glass and ceramic transfer. 27 x 24 x 4cm
Photography by Ester Segarra



Plate 8.
Helen Slater Stokes *Acuity* (2018)
Kiln formed glass and ceramic transfer. 27 x 24 x 4cm
Photography by Helen Slater Stokes

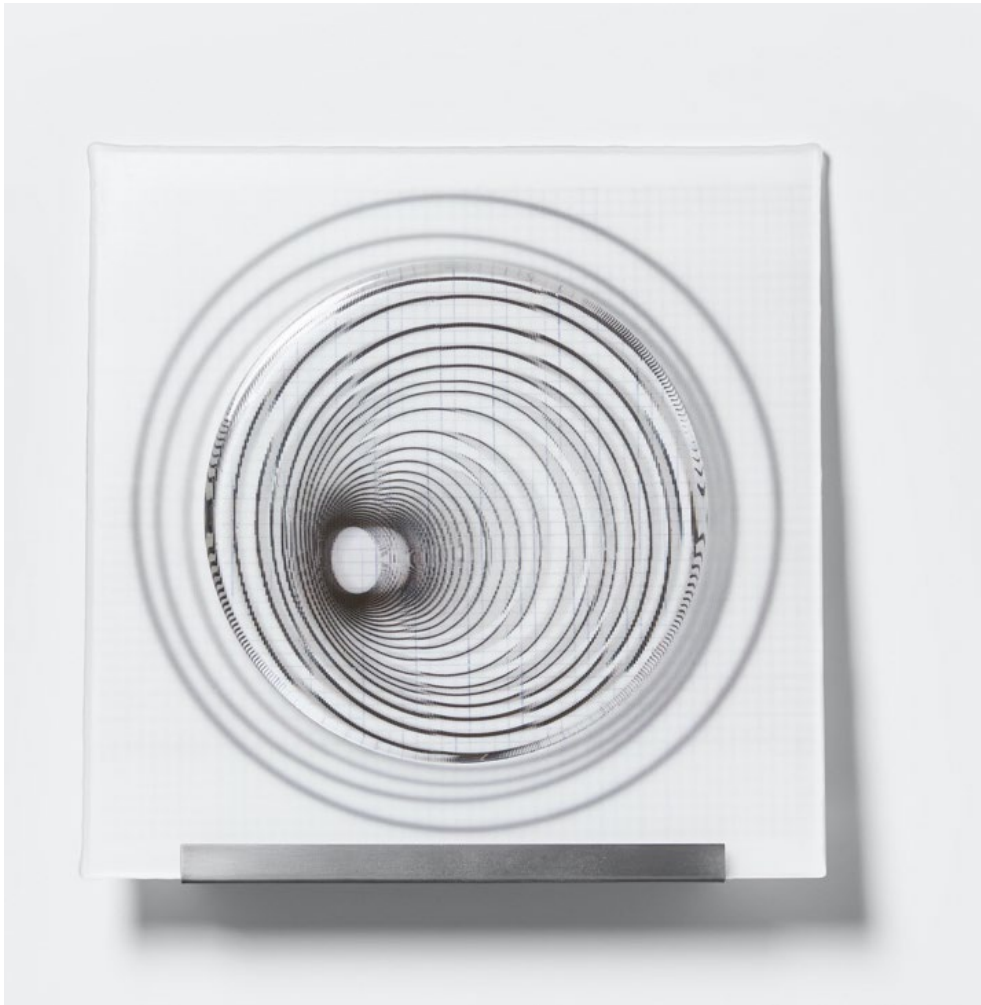

Plate 9.
Helen Slater Stokes Asymmetric Cone (2019)
Kiln formed glass, ceramic transfer, steel. 41 x 41 x 6.5cm
Photography by Alick Cotterill

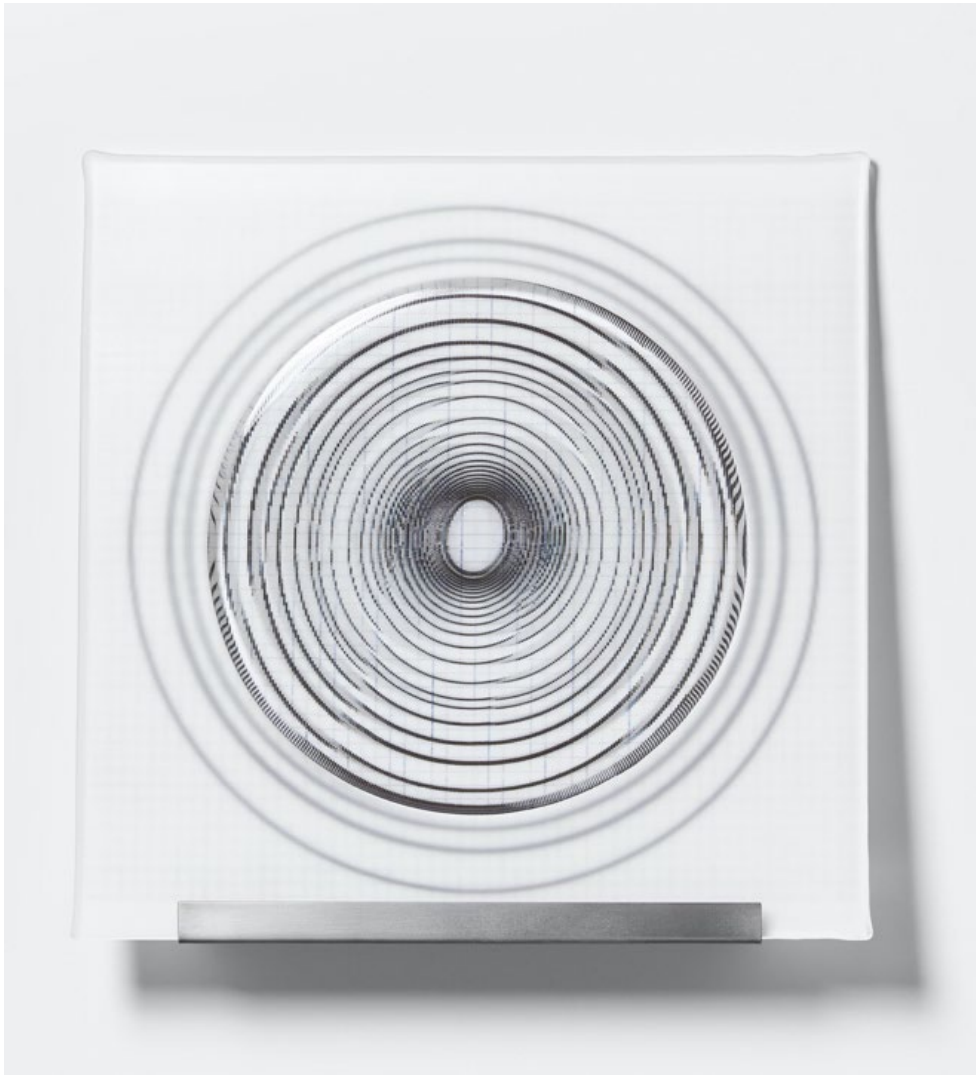

Plate 10.
Helen Slater Stokes Symmetric Cone (2019)
Kiln formed glass, ceramic transfer and steel. 41 x 41 x 6.5cm
Photography by Alick Cotterill



Plate 11.
Helen Slater Stokes *Asymmetric Vortex* (2019)
Kiln formed glass, ceramic transfer and steel. 41 x 41 x 6.5cm
Photography by Alick Cotterill



Plate 12.
Helen Slater Stokes *Breaking Ground* (2019)
Kiln formed glass, screen print enamels, ceramic transfer and steel. 48 x 38 x 6.5cm
Photography by Alick Cotterill

Appendix II: Practical Testing

A. The Image in Glass

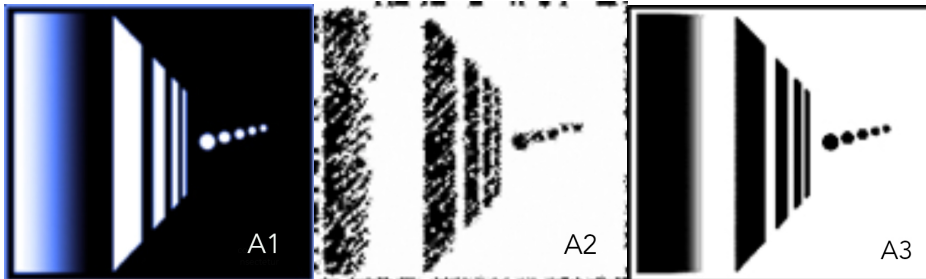

A.1. Sandblasting

Fusing a clear top sheet onto a sandblasted sheet of glass

Set up	Firing	Temp rate	Optical Result	Issues
Sandblasted sheet fused below clear Bullseye Tekta Scale: 9 x 8 x 0.3 cm	0-538	100	Sandblasted Design - Design almost totally lost - Only a few faint bubbles left where the sandblasted design was.	Sandblasted image - Image lost. - Possibly testing with a coarser sandblasting grit would create greater distinction.
	538-780	1000		
	780	HOLD 15 mins		
	Switch Off			

A.2. Painted Underglaze Enamel

Painting Underglaze Enamel onto sheet glass

Set up	Firing	Temp rate	Optical Result	Issues
Clear Bullseye Tekta fired onto an underglaze enamel painted sheet of Tekta glass. Scale: 9 x 8 x 0.3cm	0-538	100	Underglaze enamel - Smooth surface. - One consistent tone apparent. - opaque - Density of pigment good. - Crisp image, no blur - Fine line and detail very difficult due to application method.	Underglaze enamel - No movement of image. - Strong black opaque. - Lack of fine line and detail due to hand application method. - No ability to translate tonal gradation.
	538-780	1000		
	780	HOLD 15 mins		
	Switch Off			

A.3. Screen Printed Underglaze Enamel

Screen-printed Underglaze Enamel on sheet glass

Set up	Firing	Temp rate	Optical Result	Issues
Screen-printed underglaze between 2 x Bullseye Tekta sheet glass Scale: 9 x 8 x 0.3cm	0-538	100	Screen-printed design - Smooth surface. - No ability to translate tonal graduation. - Density of pigment good - opaque - Crisp image, no blur - A few bubbles around the design. - Fine line and detail quite good. But limited by the print process.	Screen Print - No movement of image. - Density of pigment good. - Bubbles apparent around the pigment, which create some distortion of image. Fine detail limited by the print process - No ability to translate tonal graduation.
	538-780	1000		
	780	HOLD 15 mins		
	Switch Off			

A.4. Fusing Ceramic Transfers

Fusing Ceramic Transfers onto sheet glass

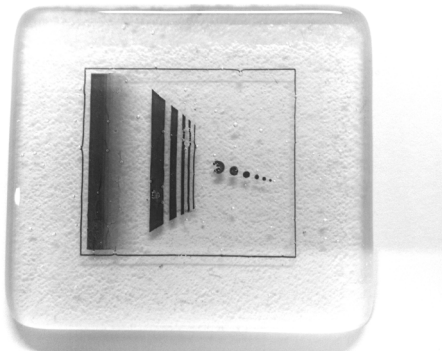

Decal fused onto Bullseye Tekta sheet glass

Scale: 9 x 8 x 0.3cm

Layers:
1 x Tekta
1 x Decal Transfer

Firing	Temp rate	Optical Result	Issues
0-538	100	Digital Decal - Smooth surface. - Ability to translate tonal graduation. - Less density of pigment. - Blacks transparent. - Crisp image, no blur - Fine line and detail very good.	Digital Decal - No movement of image. - Paler translation of image on firing.
538-780	1000		
780	HOLD 15 mins		
Switch Off			

A.5. Table of Result for Initial Image Testing
 – Images fused between sheets of 3mm Bullseye Tekta

Image/Pigment	Technique	Effect	Effectiveness
Sandblasting	Sandblasted image onto a sheet using a digital resist. Fused between 2 sheets of glass	A very faint image created due to the trapping of small bubbles in the pattern of the sandblasted image.	<ul style="list-style-type: none"> - Image very faint and in parts unreadable - No tonal graduation - No ability to add colour
Ceramic underglaze enamel	Hand painted onto sheet glass. Fused between 2 sheets of glass	Pigment varies in weight from black to grey, with brush marks apparent. As this is hand painted it also lacks precision.	<ul style="list-style-type: none"> - No tonal graduation - Weight of line varies - Lacks precision
Silkscreen Print	Ceramic Under Glaze Silkscreen printed directly on to sheet glass. Fused between 2 sheets of glass	Pigment is consistently even and precise. Black colouration is strong, almost opaque.	<ul style="list-style-type: none"> - Good strength of colour - Precise mark capability - No tonal graduation
Digital Ceramic Transfer (Decal)	Ceramic digital transfer applied to sheet glass. Fused between 2 sheets of glass	Pigment is consistently even and precise. Black colouration is slightly transparent.	<ul style="list-style-type: none"> - Good strength of colour (using black) - Precise mark capability - Tonal graduation

At this stage it was necessary to begin testing ceramic transfers, as the most accurate and versatile medium, when fired within glass block. This was done to assess if they could be successfully suspended without movement or distortion with these blocks.

B. Ceramic Transfer Within Glass

B.1. Test firing 1

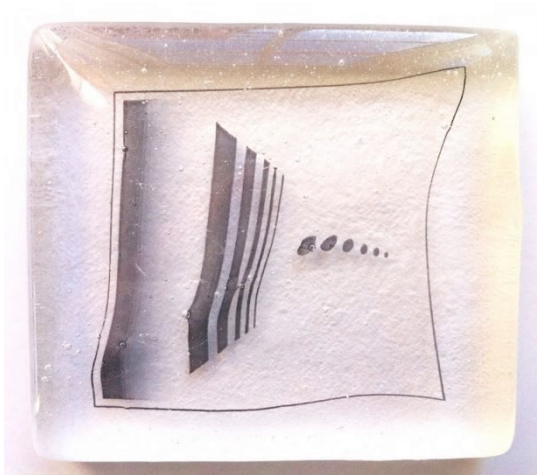

Casting using pre-fused decal transfers

Layers:
 1 x Tekta
 1 x Tekta with pre-fused decal Transfer
 2 x Tekta sheets on top

Pre-fusing of the transfer onto the sheet glass

Initial Fuse Firing 1	Temp rate	Optical Result	Issues
0-538	80	- Very little movement of image - Good fusing - No devitrification - Minimal bubbles	Issues None
538-677	50		
677	HOLD 1hr		
677-770	1000		
770	HOLD 20 min		
Switch Off			

Casting into blocks

Casting Firing 1	Temp rate	Optical Result	Issues
0-538	100	Digital Decal - Smooth - Ability to translate tonal graduation - Less density of pigment. - Blacks more washed out. - Crisp image, no blur - Fine line and detail very good	Digital Decal - The movement of image - in different directions - Paler translation of image on firing.
538-810	1000		
810	HOLD 1.5hrs.		
810-500	1000		
500-482	50		
482	HOLD 2hrs		
Switch Off			

B.2. Test Firing 2

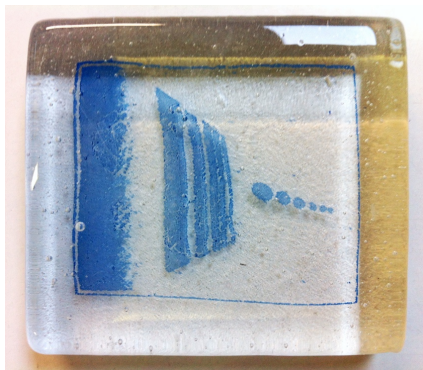

Casting using Decals

Layers:
 1 x Tekta
 1 x Decal Transfer on Tekta
 2 x Tekta
 Glass sheet on top

Pre-fusing of the transfer onto the sheet glass

For fuse firing – see initial fuse firing 1

Casting Firing 2	Temp rate	Optical Result	Issues
0–538	100	Digital Decal- - Smooth - Less density of pigment. - Decal image good - Possibly slightly less movement	Issues - Movement of image – less top to bottom - Still Pale image colour
538–805	1000		
805	HOLD 1hr		
810–500	1000		
500–482	50		
482	HOLD 2hrs		
Switch Off			

B.3. Test Firing 3

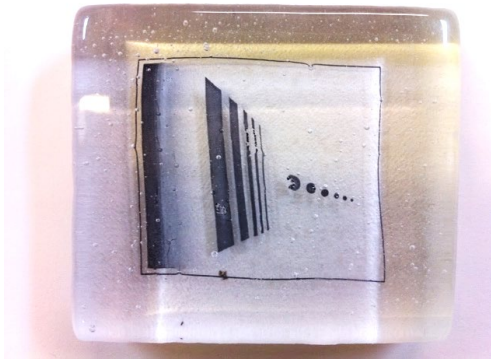

Casting using pre-fused ceramic transfers

Layers:
 1 x Tekta
 1 x Fused Decal
 2 x Tekta
 Glass Sheet

For fuse firing – see initial fuse firing 1

Casting Firing 3	Temp rate	Optical Result	Issues
0–538	80	Casting - Good cast - Less top to bottom movement of decal - Much more intense colour with 2 x decal overlay.	Movement from side to side – almost stretching of the image during firing as glass moves.
538–677	50		
677	HOLD 1hr		
677–800	1000		
800	HOLD 45 mins		
810–500	1000		
500–482	150		
482	HOLD 2hrs		
Switch Off			

Results

Top to Bottom Movement over three different casting firings

(Edge-on view)

Firing Schedule 1

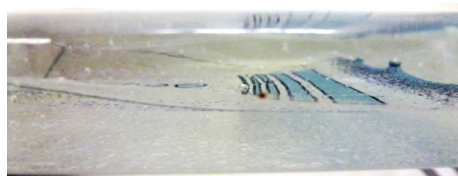

Exploring the Optical Perception of Image Within Glass

Firing Schedule 2- Top Temp down from 810 to 805°C.

Hold/soak reduced from 1.5hr to 1hr.

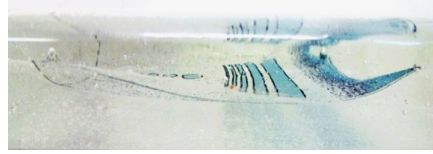
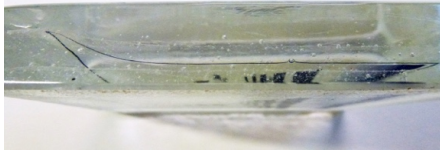

Firing Schedule 3- Top Temp down from 805 to 800°C.

Hold/soak reduced from 1hr to 45mins.

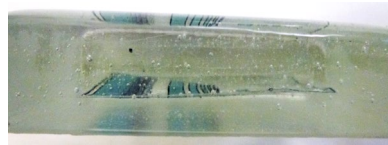
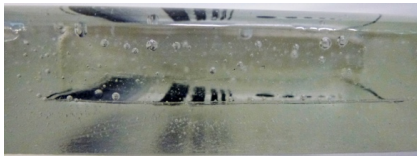

B.4. Double layer of Decal to intensify colour

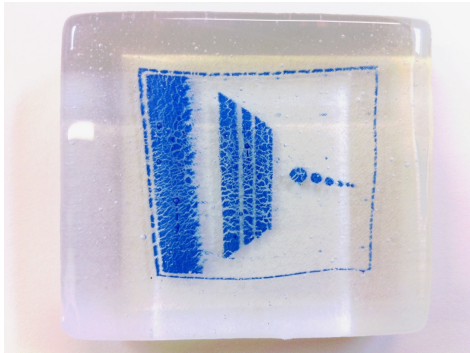

Casting using pre-fused ceramic transfers

Layers:
 1 x Tekta
 1 x Fused Decal (x2)
 2 x Tekta
 Glass Sheet

For fuse firing – see initial fuse firing 1

Set up	Casting Firing 3	Temp rate	Optical Result	Issues
Double layer of decal fused onto 1 sheet of Tekta – then cast into a block	0-538	80	<ul style="list-style-type: none"> - Good cast - Less top to bottom movement of decal - Much more intense colour with 2 x decal overlay. 	<ul style="list-style-type: none"> - Movement from side to side- almost stretching of the image during firing as glass moves. - Double layer of decal creates a cracking on the surface of the image, due to the covercoat. This is more apparent in the casting stage than the fusing.
	538-677	50		
	677	HOLD 1hr		
	677-810	1000		
	800	HOLD 45mins		
	810-500	1000		
	500-482	150		
	482	HOLD 2hrs		
Switch Off				

B.5. Test Firing 5

Intensified Colour Decals

- Note - Additional application of pigment by the print bureau to add pigment and colour intensity

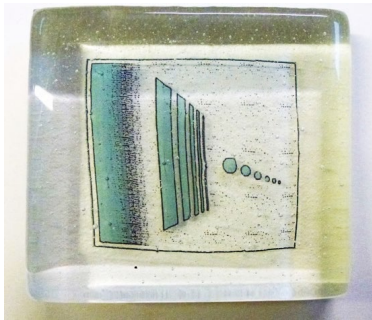

Casting using Fused Decals

Layers:
 1 x Tekta
 Fused decal
 3 x Tekta
 Glass sheet

For fuse firing – see initial fuse firing 1

Casting Firing 5	Temp rate	Optical Result	Issues
0-538	60	- Good cast - Less top to bottom movement of decal - Much more intense colour	- Movement less. - Colour intensity good - Pigment appears almost opaque.
538-677	50		
677	HOLD 1hr		
677-800	1000		
800	HOLD 45mins		
800-500	1000		
500-482	150		
482	HOLD 2hrs		
Switch Off			

B.6. Test Firing 6

Intensified Colour Decals

Fused Pieces Ground to original size

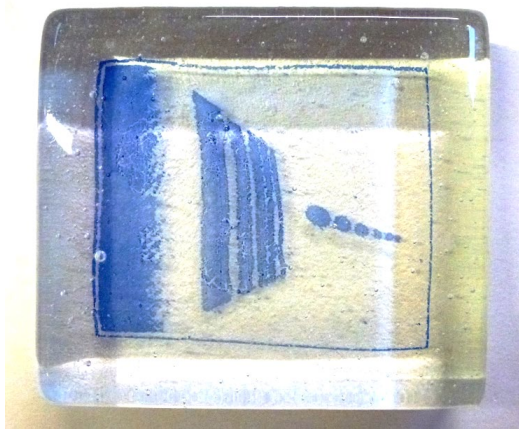

Casting using Fused Decals

Layers:
 1 x Tekta - base
 Fused decal
 3 x Tekta glass sheet – on top

For fuse Firing – see initial fuse firing 1

Casting Firing 6	Temp rate	Optical Result	Issues
0-538	60	<ul style="list-style-type: none"> - Good cast - Less top to bottom movement of decal - Much more intense colour 	<ul style="list-style-type: none"> - Slight movement of image - Colour intensity good - Pigment appears almost opaque.
538-677	50		
677	HOLD 1hr		
677-800	1000		
800	HOLD 45mins		
800-500	1000		
500-482	150		
482	HOLD 2hrs		
Switch Off			

B.7. Test Firing 7

Reduced Top Temperature and hold.

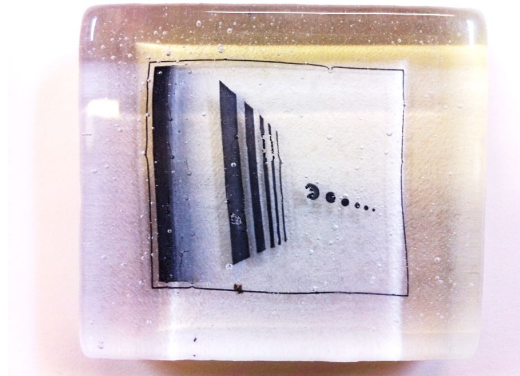

Casting using Fused Decals

Layers:
 1 x Tekta at base
 1 x pre-fused decal on Tekta
 3 x Tekta glass sheet on top

For fuse firing - see initial fuse firing 1

Casting Firing 7	Temp rate	Optical Result	Issues
0-538	60	<ul style="list-style-type: none"> - Good cast - Intensity of colour not clearly marked. 	<ul style="list-style-type: none"> - Movement from side to side still apparent – almost stretching of the image during firing as glass moves.
538-677	50		
677	HOLD 1hr		
677-780	1000		
780	30mins		
780-500	1000		
500-482	150		
482	HOLD 2hrs		
Switch Off			

B.8. Test Firing 8

Reduction in top temperature and hold

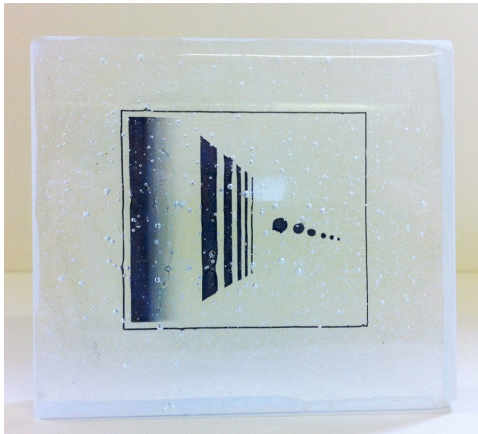

Casting using Fused Decals

Layers:
 1 x Tekta
 1 x Pre-fused decal on Tekta
 3 x Tekta on top

For fuse firing - see initial fuse firing 1

Casting Firing 8	Temp rate	Optical Result	Issues
0-538	60	-	No movement of image
538-677	50	- Good cast	
677	HOLD 1hr	- Intensity of colour good.	
677-770	1000		
770	10 mins		
770-500	1000		
500-482	150		
482	HOLD 2hrs		
Switch Off			

C. Reverse Perspective Castings

C.1. Reverse Perspective Casting –Treeline



Glass Type: Bullseye Glass
 Dimensions: 48.5 x 25.5 x 9.5 cm
 Image: Ceramic Transfer

C1. Decal Firing	Temp Rate	Optical Result	Issues
0–538	60	- Image fired on to sheet glass. Some evidence of cover coat marks. But all burned off	- None - Decal good
500–650	100		
650	Hold 20 mins		
650–770	Full		
770	Hold 6mins		

C1. Casting	Temp Rate	Optical Result	Issues
0–538	80	- Clear Casts - A few bubbles within the casting. - Decal images show only slight movement.	- A good casting. - Few Bubbles - Tonal strength appears to have faded slightly, as expected with deal transfer.
538–677	150		
677	Hold 3hrs		
677–780	Full		
780	Hold 45min		
780–500	Full		
500–482	150		
482	Hold 12hrs		
482–425	2		
425–371	3		
371–200	10		
Switch off			

C.2. Reverse Perspective Casting – Geometric Perspective

Packing the mould



Glass Type: Bullseye Glass
 Dimensions: 42cm diameter x 12cm
 Image: Ceramic Transfer

C2. Decal Firing	Temp Rate	Optical Result	Issues
0–538	60	- Image fired on to sheet glass. Some evidence of cover coat marks. But all burned off	None Decal good
500–650	100		
650	Hold 20mins		
650–770	Full		
770	Hold 6mins		

C2. Casting	Temp Rate	Optical Result	Issues
0–538	80	- Clear Casts - Cracking apparent. See image below.	Major cracking to edges of casting
538–677	150		
677	Hold 3hrs		
677–780	Full		
780	Hold 45min		
780–500	Full		
500–482	150		
482	Hold 12hrs		
482–425	2		
425–371	3		
371–200	10		
Switch off			

Exploring the Optical Perception of Image Within Glass

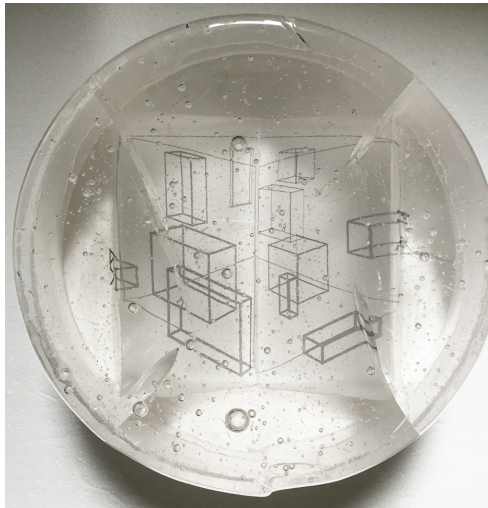

Cracking Issues – notes

Re-firing the casting – Kiln shelf placed above the casting in the kiln to maintain insulating heat.

An extended annealing schedule applied as below.

C2. Casting – 2	Temp Rate	Optical Result	Issues
0–100	10	<ul style="list-style-type: none"> - Clear Casts - Cracking apparent. As before 	Still cracking to edges of casting
100–538	25		
538–677	150		
677	Hold 1hr		
677–800	Full		
800	Hold 45min		
800–500	300		
500–482	150		
482	Hold 12hrs		
482–425	1		
425–371	2		
371–200	5		
Switch off			

Finally, it was recognised that this was formal stress, having removed the mould. This was at the central point of the internal core. The mould was remade with a shallower central angle and cast using firing schedule below.

C2. Casting – 5	Temp Rate	Optical Result	Issues
0–200	50	<ul style="list-style-type: none"> - Clear Casts - Cracking apparent. As before 	Still cracking to edges of casting
200–677	100		
677	Hold 30mins		
677–780	Full		
780	Hold 30mins		
780–500	Full		
500–482	80		
482	Hold 16hrs		
482–425	1		
425–371	2		
371–200	6		
Switch off			

D. Further Testing of Complex Ceramic Transfer Images in Glass

D.1. Sea Scapes – Photographic Decals

Firing ceramic transfers onto Spectrum 96 glass



Applied Decal

Layers:

1 x Spectrum 96 sheet
1 x Decal Transfer

Dimensions: 13cm
diameter x 3mm

Kiln Firing 1 – Fusing	Temp Rate	Optical Result	Issues
0–500	60	- Image fired on to sheet glass. Some evidence of cover coat marks.	Possibly water traps under decal – some slightly brown in centre. Cover coat should have burnt off. (Recommended firing 800–860°C).
500–624	150		
624	Hold 1hr		
624–734	95		
770	Hold 30mins		
			Firing adopted for both Spectrum and Bullseye glass.

D.2. Photographic Decals – layered into castings – Test 1
 Pre-fired decal images in open casting of Spectrum 96 glass



Pre-Fired decals layered into a mould.

Layers:
 15 x Spectrum 96 sheet
 2 x Decal Transfers (9th & 12th layers)

Dimensions: 13cm diameter x 11cm deep

Kiln Firing 2 – Casting 6cm deep bowl shape	Temp Rate	Optical Result	Issues
0–624	150	<ul style="list-style-type: none"> - Clear Casts - A few bubbles within the casting. - Decal images show only slight movement. 	<ul style="list-style-type: none"> - A good casting. - Large bubble central to the cast. - Tonal strength appears to have faded slightly.
624	Hold 2hrs		
624–743	93		
743	Hold 1hr		
743–806	@ Full		
806	Hold 30mins		
806–510	@ Full		
510	Hold 3hrs		
510–425	2		
425	Hold 2hrs		
425–370	3		
370–200	28		
Switch off			

D.3. Photographic Decals – layered into castings – Test 2

Pre-fired on decal images in open casting using Bullseye Tekta glass



Pre-Fired decals layered into a mould.

Layers:
15 x Bullseye Tekta sheet
2 x Decal Transfers (9th & 12th layers)

Dimensions: 13cm diameter x 11cm deep

Kiln Firing 2 – Casting 6cm deep bowl shape	Temp Rate	Optical Result	Issues
0–538	80	<ul style="list-style-type: none"> - Clear Casts - Very few bubbles within the casting. - Decal images show only slight movement. - No loss of tone - Very little polishing and finishing needed 	None Slight flex of image
538–677	150		
677	Hold 3hrs		
677–780	@ Full		
780	Hold 45mins		
780–500	@ Full		
500–482	150		
482	Hold 8hrs		
482–427	4		
427–371	7		
371–200	22		
Switch off			

D.4. Screen Printed Image Within Fused Glass

Using Bullseye glass

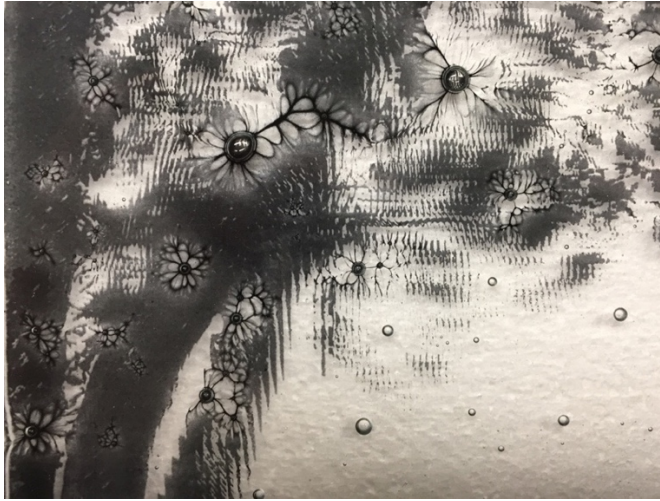

Screen-printed
Lenticular image

Layers:
1 x Bullseye Crystal
Clear plus Screen
Printed Image
1 x Bullseye Crystal
Clear

Dimensions: 30cm x
21cm x 6mm

Kiln Firing 2	Temp rate	Optical Result – Approx. 3mm lens	Issues
0–500	60	<ul style="list-style-type: none"> - Clear fusing - Good intensity of pigment - bubbles within the casting. - Bubbles particularly on the screen-printed image. 	Too many bubbles on and around the image These distort the image dramatically and negate the registry of image to lens.
500–677	40		
677 Hold	1hr		
677–780	Full		
780 Hold	30mins		
780–510	Full		
510	Hold 1.5hrs		
510–425	60		

Exploring the Optical Perception of Image Within Glass

D.5. Fusing Large Ceramic Transfers – Test 1

Firing A4 Lenticular Ceramic Transfer between two sheets of Spectrum 96 glass

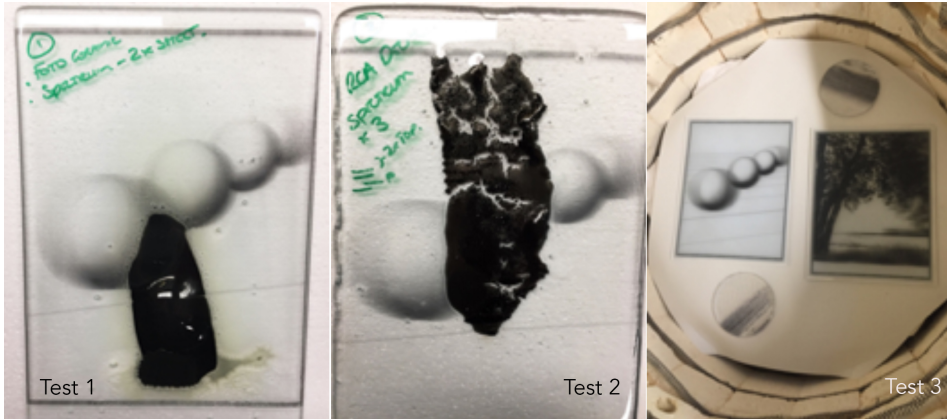

Set up – Test 1	Kiln Firing	Temp rate	Optical Result	Issues
Applied Decal Layers: 1 x Spectrum 96 clear sheet 1 x Decal Transfer on Spectrum 96 clear sheet 1 x Spectrum 96 clear sheet Dimensions: 30cm x 21cm x 6mm	0–500	60	- Large bubble and burnout ash within the fusing	<ul style="list-style-type: none"> - Burnout of the cover coat. - Need to try to re-fine firing, to allow the burn off of the cover coat. - Possible water trap – again refine firing.
	500–624	150		
	624 Hold	1hr		
	624–734	95		
	734–770	Full		
	770 Hold	10mins		
	Switch off			

D.6. Fusing Large Ceramic Transfers – Test 2

Firing A4 Lenticular Ceramic Transfer between Spectrum 96 glass. This time more glass is fired on top of the transfer layer in an attempt to squeeze the trapped air out.

Firing altered to a decal manufacturer’s recommendation

Set up – Test 2	Kiln Firing	Temp rate	Optical Result	Issues
Applied Decal Layers: 1 x Spectrum 96 1x Decal Transfer 2 x Spectrum 96 glass – to add weight. Dimensions: 30cm x 21cm x 6mm	0–85	10	<ul style="list-style-type: none"> - Still a large bubble and burnout ash within the fusing - Visibly less air trapped 	Burnout of the cover coat. Need to try to refine firing, to allow the burn off of the cover coat. Decided to pre-fire the decal on to the surface of the sheet glass to burn off the cover coat. Then fuse between sheets as a secondary firing.
	85	Hold 20mins		
	85–175	65		
	175	Hold 15mins		
	175–260	120		
	260	Hold 15mins		
	260–535	315		
	535	Hold 10mins		
	535–624	300		
	624	Hold 1hr		
	624–743	@ Full		
	743	Hold 30mins		
	743–800	@ Full		
800	Hold 10mins			

D.7. Fusing Large Ceramic Transfers – Test 3

Firing A4 Lenticular Ceramic Transfer on top of Spectrum 96 glass. To allow for the burn off of the decal cover coat.

Set up – Test 3	Kiln Firing	Temp rate	Optical Result	Issues
Applied Decal Layers: 1 x Spectrum 96 1 x Decal Transfer Dimensions: 30cm x 21cm x 6mm	0–500	60	<ul style="list-style-type: none"> - Strong images - No distortion of image - No bubbles or air traps - Image fixed onto the sheet glass 	Burnout of the cover coat successful Images fired onto the surface of the sheet glass.
	500–650	100		
	650–770	@ Full		
	770	Hold 6mins		
	Switch off			

E. Lenticular Lens Fabrication

E.1. Lenticular Lens – Kiln Firing 1

Using Spectrum Glass - Crystal Clear

A4 size 3D lens -.Firing used for both. (2.8-3.mm) 20lpi and (1.8mm-2.mm) 20lpi.

Using 2mm and 3mm sheet glass.



Kiln Firing 1	Temp rate	Result 3mm lens	Result 2mm lens
0-500	60	<ul style="list-style-type: none"> - Clear Casts - Very few bubbles within the casting. - Lens detailing seams good - Relatively even thickness - Slightly thicker around the edges – approx. 1.5cm all around. 	Clear Casts <ul style="list-style-type: none"> - Very few bubbles within the casting. - Lens detailing patchy - Uneven thickness–rippled. - Slightly thicker around the edges – approx. 1.5cm all around.
500-677	40		
677 Hold	1hr		
677-780	Full		
780 Hold	10mins		
780-425	Full		
425 Hold	1hr		
Switch off			

E.2. Lenticular Lens – Kiln Firing 2

Using Spectrum Glass - Crystal Clear for a 3D lens

A4 size lens - (2.8-3.1mm) 20lpi and (1.8mm-2.1mm) 20lpi.

Using 2mm and 3mm sheet glass.

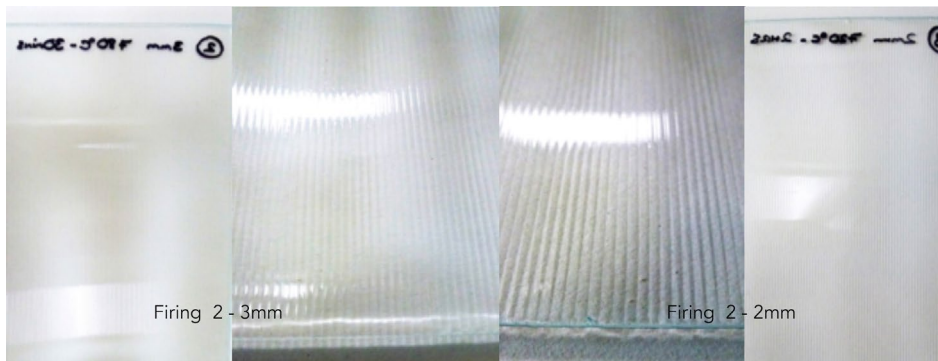

Kiln Firing 2	Temp rate	Result 3mm lens	Result 2mm lens
0-500	60	- Clear Casts	- Clear Casts
500-677	40	- Very few bubbles within the casting.	- Very few bubbles within the casting.
677 Hold	1hr	- Lens detailing seams good	- Lens detailing seams good
677-780	Full	- Relatively even thickness	- Lens thickness very uneven
780 Hold	30mins	- Slightly thicker around the edges – approx. 1.5cm all around.	- Ridge on top of the lens
780-510	Full		
510	Hold 1.5hrs		
510-425	60		
425	Hold 1 hr		
Switch off			

After extensive testing this firing proved the most effective in forming a lenticular lens

E.3. Lenticular Lens – Kiln Firing 3

Using Spectrum Glass - Crystal Clear for a 3D lens

A4 size lens - (2.8-3.1mm) 20lpi and (1.8mm-2.1mm) 20lpi.

Using 2mm and 3mm sheet glass.

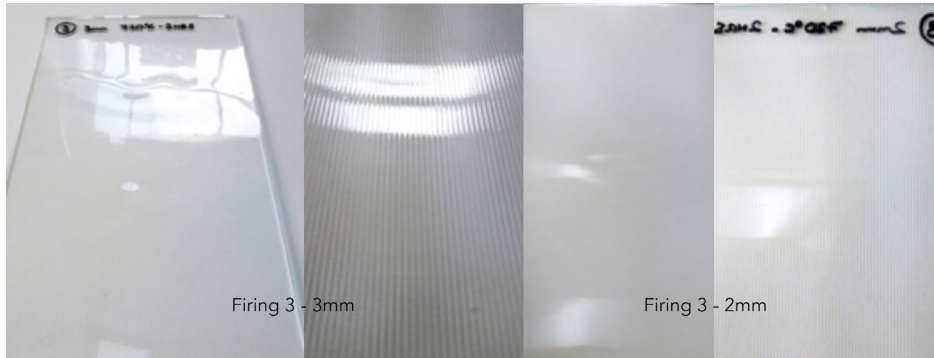

Kiln Firing 3	Temp rate	Results 3mm lens	Result 2mm lens
0-500	70	<ul style="list-style-type: none"> - Clear Casts - Very few bubbles within the casting. - Lens detail not captured. - Lens thickness very uneven - Ridge on top of the lens –Lens seems to have contracted in centre and bending up to the edges. 	<ul style="list-style-type: none"> - Clear Casts - Very few bubbles within the casting. - Lens detailing seams good - Lens thickness very uneven - Ridge on top of the lens
500-677	40		
677 Hold	1hr		
677-720	Full		
720 Hold	2hours		
720-510	Full		
510	Hold 1.5hrs		
510-425	60		
425	Hold 1hr		
Switch off			

E.4. Lenticular Lens – Kiln Firing 4

Using Spectrum Glass - Crystal Clear for a thinner 3D lens

A4 size lens - (2.8 - 3.1mm) 20lpi and (1.8mm - 2.1mm) 20lpi.

Using 2mm and 3mm sheet glass.

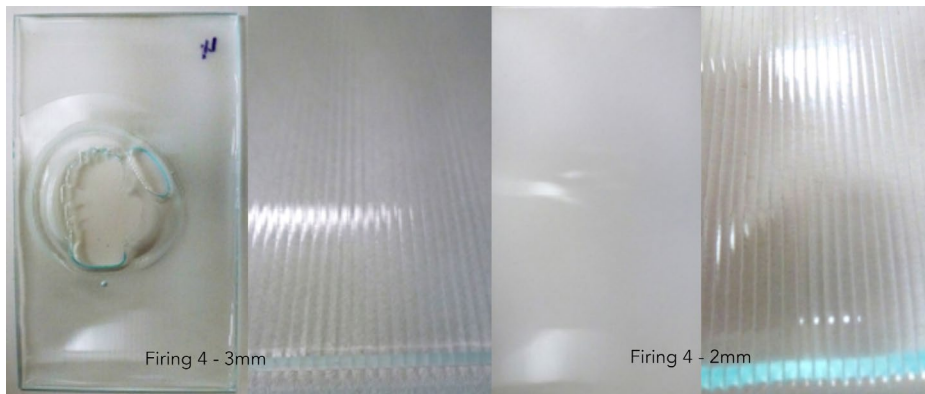

Kiln Firing 4	Temp rate	Results 3mm lens	Result 2mm lens
0-500	60	Terrible casting - Bubbles within cast and large split in lens – in centre - Mould rep-dried – so no moisture present.	Clear Casts - Very few bubbles within the casting. - Lens detail good. - Lens thickness good
500-800	Full		
800 Hold	30mins		
800-510	Full		
510-425	60		
425	Hold 1hr		
Switch off			

E.5. Lenticular Lens – Kiln Firing 5

Using Spectrum Glass - Crystal Clear for a thinner 3D lens

A4 size lens - (2.8 - 3.1mm) 20lpi and (1.8mm - 2.1mm) 20lpi.

Using 2mm and 3mm sheet glass.

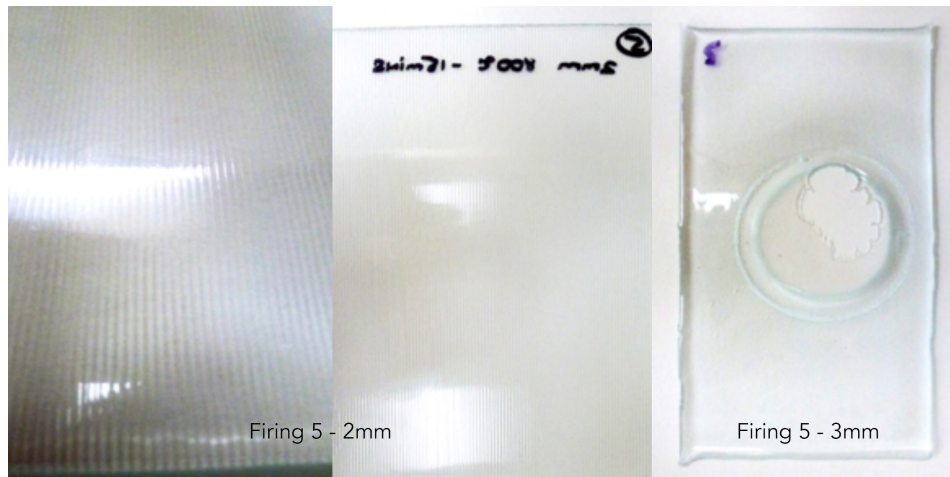

Kiln Firing 5	Temp rate	Result 3mm lens	Result 2mm lens
0-500	60	<ul style="list-style-type: none"> - Moulds dry and moisture tested. - Terrible cast – again bubbled in centre to split the casting - Splitting in the same place as the last firing with 3mm lens. 	Moulds dry <ul style="list-style-type: none"> - Lens cast well - Detail looks very good - Lots of drag at edges – shrinkage – feathered edges.
500-800	Full		
800 Hold	15 mins		
800-510	Full		
510-425	60		
425	Hold 1hr		
Switch off			

E.6. Industry Standard Lenticular Lens Calibration Test Sheet

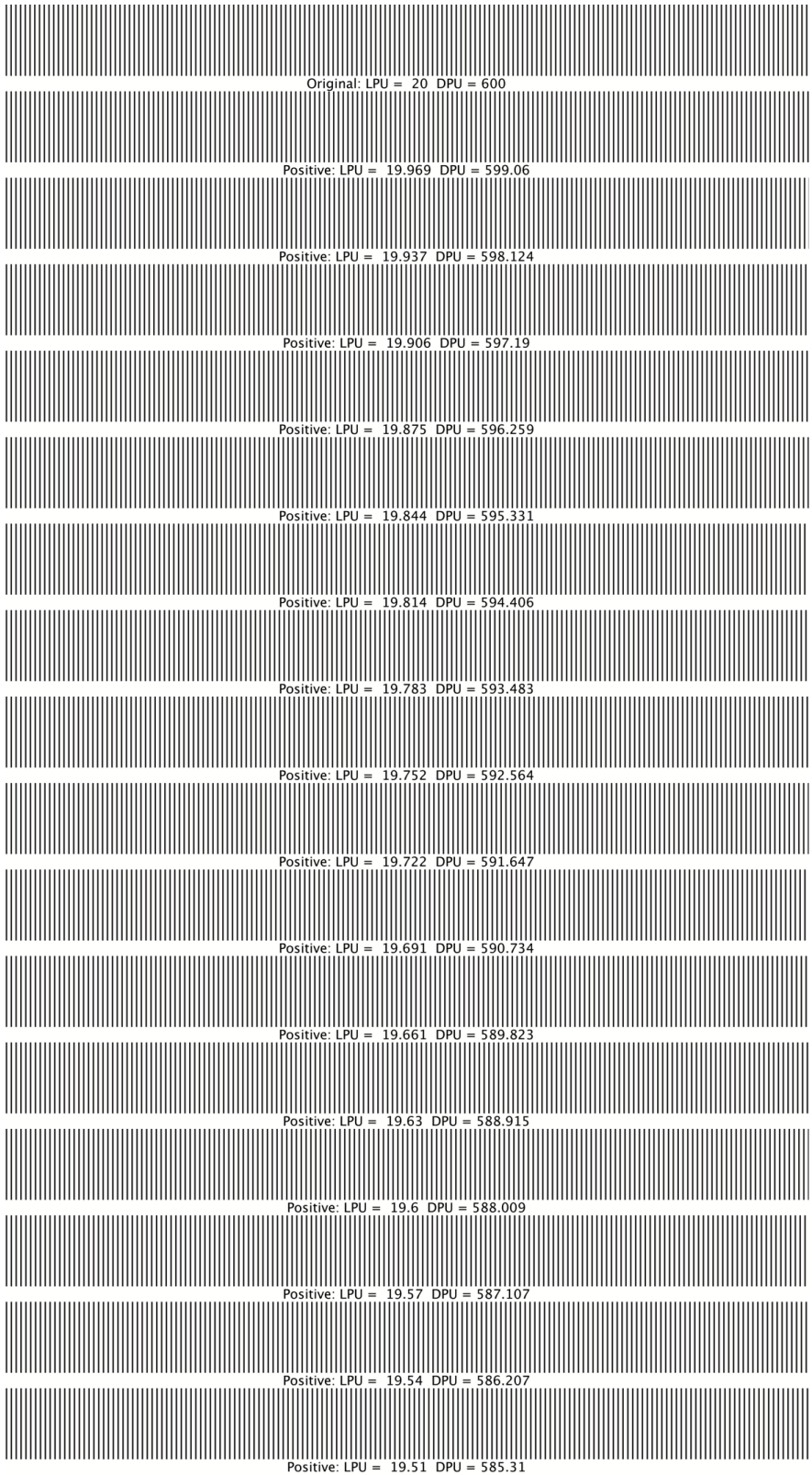

F. Vacuum Casting Tests

F.1. Priory Casting Ltd – Metal Casting Equipment.



Melt furnace at Priory Castings Ltd

A gas-fired furnace, used to melt metals from Pewter to brass/bronze, working with temperatures from 538 to 1,232°C.

With Gold casting at 1,010°C, Silver– 962 and Platinum melting at 1,773°C.



Detail of the furnace during a brass melt

- Cover removed to view the crucible.
- Crucible of Brass at top temperature of 1,232°C
- Metal glowing prior to pour.



Vacuum chamber – before the next mould is fixed in place

- Pipe to the right-hand side links the chamber to the vacuum pressure pump, where the correct pounds per square inch are applied dependant on the metal type being cast.
- The top rim shows putty applied to the edge of the previous casting to ensure an airtight fit to the top edge of the mould once dropped into the chamber.



Vacuum pressure gauge and pump system to create the vacuum

- Pump on the right-hand side with central pressure gauge.
- Heat resistant gauntlet on top of the second chamber used to handle hot moulds once cast into, as the steel outer casing to the investment remains hot during the casting process. This should help with glass flow, as it does with metal, but also ensure the mould can be moved to a kiln quickly, without losing too much heat, ready to anneal the cast glass.

Exploring the Optical Perception of Image Within Glass

- Moulds at this stage have been de-waxed using a steaming box and pre-fired in a small kiln to burnout any last residue and dry the moulds out thoroughly.
- During the casting pour, the moulds are taken warm from the kiln, to alleviate chill marks on the casting metal and help metal flow. This is something that will be maintained within the glass casting tests, but the glass casting moulds will be held at a higher temperature to try to get the maximum flow from the glass melt into the mould, as glass has a lower level of liquidity than the majority of molten metal pours.



Mould prior to casting

- The putty seal around the metal mould casing ensures a sound air-seal to the vacuum.
- Top holes act as reservoirs to the casting forms below.
- With the glass casting tests these will be of varying gauges to see how well the glass will flow into the mould. To assess the fineness of sprig that can be used.
- The shallow curve to the top of the pre-cast mould acts as crucible for the casting medium once poured, before the vacuum is switched on. Pre-pouring the material into this settling area ensures that all reservoir holes are covered by the casting material prior to the vacuum being turned on. If this methodology is not used, and the vacuum is switch on as the molten casting material is pour onto the mould, the vacuum would start to suck air into the

casting mould instead of the casting material and this trapped air would limit flow of the material into the mould.



Molten brass sitting on the top of the mould - having been poured from the crucible

- Pre-pouring the material into this settling area ensures that all reservoir holes are covered by the casting material prior to the vacuum being turned on.
- This is particularly important when testing glass casting, as the glass is not dense enough to push the air out of the mould, so creating areas where the glass doesn't fill, i.e. missing sections of the casting. Also it is important to point out that this air would be cold air, so cooling the casting mould and making the glass set too quickly, before it has chance to fill the detail of the casts below.



Brass casting mould taken off the vacuum chamber and put to one side once poured to cool

F.2. Mould Preparation

Outer Steel Casting Flask

- This has to be placed on a coated board, which is as close as possible to the diameter of the casing.
- The baseboard then needs a wax hump reservoir fixed to it. This will form the top reservoir on the mould, once ready for casting, and enables the casting material to settle above the sprigs/reservoir channels before the vacuum is switched on.



Wax reservoir on the baseboard

- This wax hump/disc is now ready for the casting waxes and their sprigs to be fixed onto, as channels to run the casting material down into the mould detail.



Morganite Clay Graphite Salamander

Exploring the Optical Perception of Image Within Glass

Casting crucible suitable for temperatures up to 1600 degrees C. to be used for the glass test castings.

This crucible has to be warmed in order to check for stress before it is used for casting. The crucible this has been placed on the furnace for 1 week to ensure it won't crack under the stress of the pouring temperatures, prior to the casting.

As it is part ceramic it can be prone to faults in production, so this is done to check it is fault free before the pour.

F.3. Glass Flow Testing

Furnace heated crucible glass pour.



Crucible heated to 1,200 degrees. Glass pour to test liquidity onto ceramic fibre paper.

Continued glass movement as crucible starts to visibly cool.

F.4. Vacuum Cast Glass Excavation and Results



The glass now needs to be carefully excavated from the investment.

Within the metal casting process this would be done by plunging the warm, post casting, mould into a large butt of cold water.

Then by vigorously shaking the mould within the water the metal would be cooled and investment washed away from the castings.

This was excavated, whilst wearing an industrial mask, using wooden modelling tools, so not to damage the glass casts within.



Here you can see the failed casting of the doll's house picture frame, as the furthest flow point of the glass and narrowest form in the mould.



Flecks of black within the cast are metal elements from the casting furnace.

A lid will be needed for the crucible during the next casting to keep any metal traces out.



Shrinkage evident from original to glass cast version

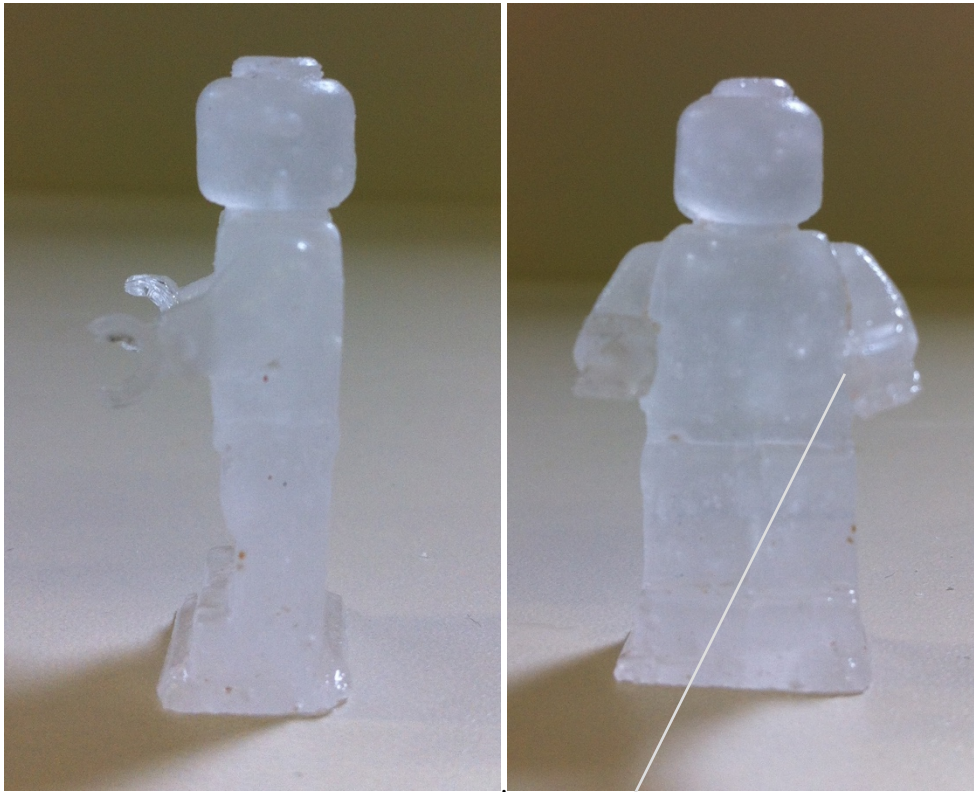

Great casting surface on the glass casts - Bubbles/seed within the casting glass evident in the light.

If this process is to be used to produce detailed lenticular lenses then further temperature testing is required with the lead crystal to determine the 'gassing - off' temperature to remove bubbles within the casts.

F.5. Burnout, Melt and Annealing Firings for Vacuum Casting

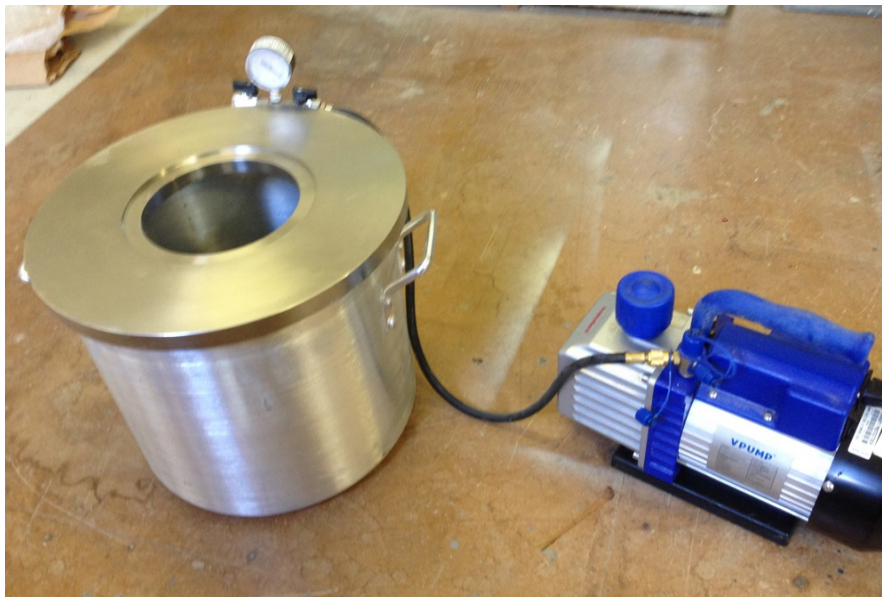

Casting Using Gaffer Glass

Burnout Kiln		Vacuum Chamber	Optical Result
0-200	70	<ul style="list-style-type: none"> - Mould taken out of kiln at approx. 600°. - Vacuum on full once the casting chamber is in place and the rim sealed. 	<ul style="list-style-type: none"> - Glass appeared to draw into the mould from the reservoir.
200	Hold 2hrs		
200-750	Full		
750	Hold 2.5hrs		
750-600	Full		
600	Hold 2hrs		

Crucible Melt		Appearance	Result
0.500	100	Glass has a good level of viscosity Pours well into mould	Low bubble ratio in final casting
500-1100	Full		
1100	Hold 30mins		

Kiln Annealing Firing	Temp rate	Optical Result	Issues
0-810	Full	<ul style="list-style-type: none"> - Clear Casts - Very few bubbles within the casting - Very good draw of glass into the mould 	None
810	HOLD 10mins		
810-500	Full		
500-482	150		
482	HOLD 2hrs		
Switch Off			

Casting Using Bullseye Casting Crystals

Burnout Kiln		Vacuum Chamber	Optical Result
0-200	70	Mould taken out of kiln at approx. 600 degrees.	Glass appears less fluid. Less drawn into the mould from the reservoir.
200	Hold 2hrs		
200-750	Full	Vacuum on full once the casting chamber is in place and the rim sealed.	
750	Hold 2.5hrs		
750-600	Full		
600	Hold 2hrs		

Kiln Annealing Firing	Temp rate	Optical Result	Issues
0-810	Full	<ul style="list-style-type: none"> - Clear Casts - Very few bubbles within the casting - Very good draw of glass into the mould - ¾ of the depth of branch cast – approx.20cm 	Not quite as big a draw into the mould, as with the Gaffer lead crystal glass.
810	HOLD 10mins		
810-500	Full		
500-482	150		Perhaps a hotter pour temperature needed for this soda-lime glass.
482	HOLD 2hrs		
Switch Off			

Casting Using Glasma – Furnace Glass

Burnout Kiln		Vacuum Chamber	Optical Result
0-200	70	Mould taken out of kiln at approx. 600 degrees.	Glass appears less fluid. Less drawn into the mould from the reservoir.
200	Hold 2hrs		
200-750	Full	Vacuum on full once the casting chamber is in place and the rim sealed.	
750	Hold 2.5hrs		
750-600	Full		
600	Hold 2hrs		

Furnace glass used - no crucible melt schedule required

Kiln Annealing Firing	Temp rate	Optical Result	Issues
0-810	Full	<ul style="list-style-type: none"> - Draw good - Glass clear - Very few bubbles within the casting - Only a small amount of the casts reached. 	Insufficient draw of the material into the mould. Glass less fluid when poured.
810	Hold10 min		
810-500	Full		
500-482	150		
482	HOLD 2hrs		
Switch Off			

G. The Lenticular Interlacing of an Image

Firstly, the image is generated in Rhino, Photoshop or Illustrator

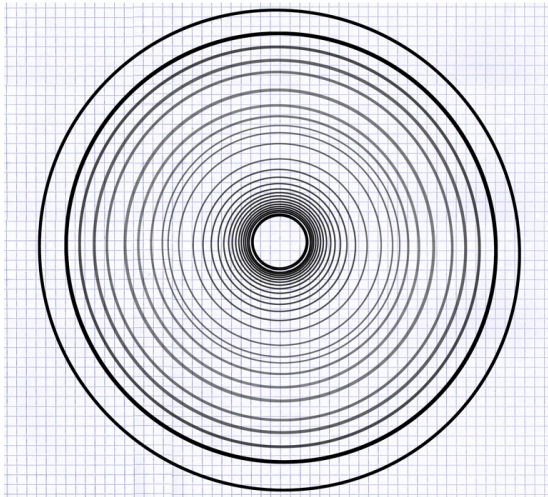

Next this image is separated into multiple layers - in this case each circle is placed on an individual layer in Photoshop.

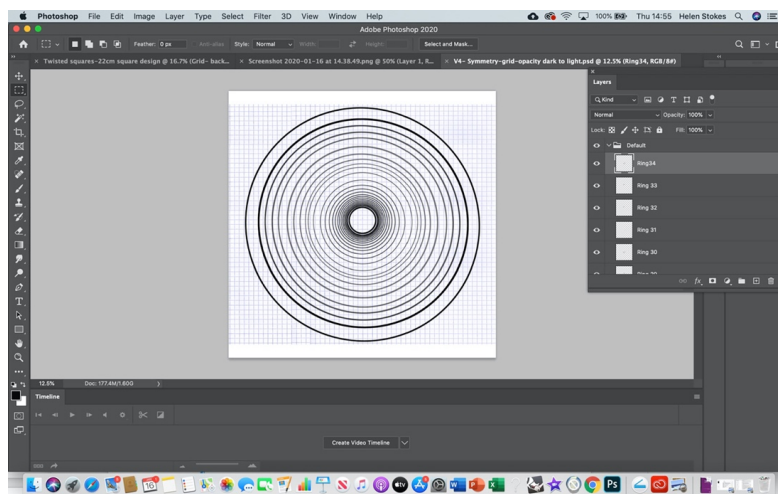

Once saved as a Photoshop file this can now be opened in Power illusion (interlacing software).

To interlace you firstly need to select the type of lens you are working to - i.e.20|pi.
Then the number of frames.

Exploring the Optical Perception of Image Within Glass

To calculate the frames use the formula below

$$N = R_{PR} / R_L$$

Where N = Number of consecutive pictures to be taken

R_{PR} = Resolution of your inkjet or colour laser printer

R_L = Number of lenticules per inch of the lenticular sheet you are going to use

i.e. For a 600dpi print resolution and meshing with a 20lpi lens

$$600/20 = 30 \text{ frames}$$

Then you can open your Photoshop image in the Power illusion software

This image is currently flat, so must be manipulated using the various features of the software to make it three-dimensional in space. (See below).

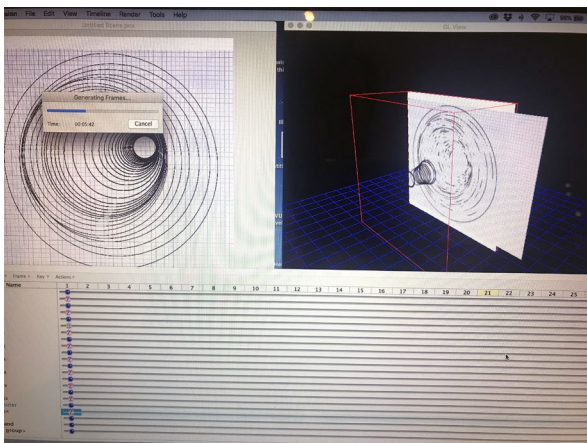
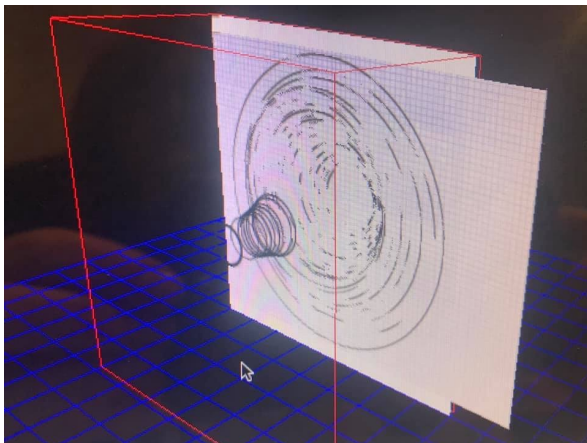

This image once converted into a three-dimensional layered image as above, can now be interlaced to the specifications set. (20lpi, print 600dpi, 30 frames)

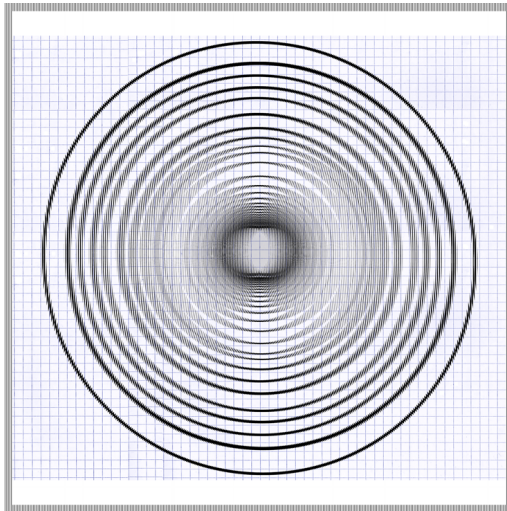

Next this interlaced image must be calibrated to the glass lens. As mentioned a glass lens has a different refractive index and so the accuracy of the interlace must be altered.

Initially the glass lens is measured using a calibration sheet (see Appendix II: E10).

For this the lens is placed on this printed calibration sheet and the line of strips on the sheet that matched the lens noted - this determines how the image must be calibrated to match this individual lens.

Once this calibration measurement is known the now interlaced image can be calibrated and re-interlaced in the software.

For this piece the calibration from the sheet was 19.78. This was the resulting interlaced image.

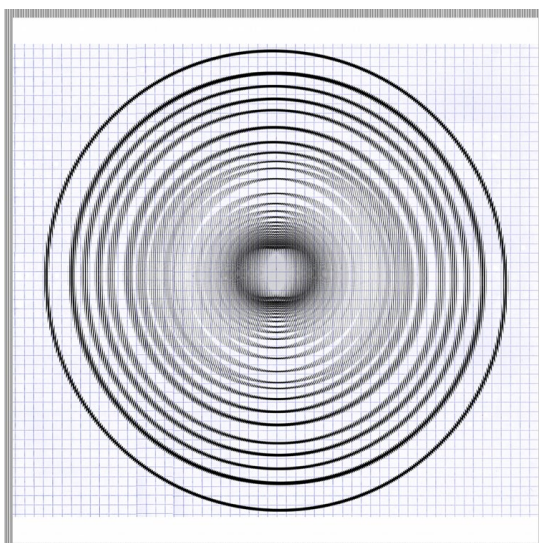

Although to the human eye this image appears identical to the previous one only the calibrated image will match the glass lens and function accurately. A lack of calibration would result in an image compatible with an acrylic lens, but one which is blurred and ineffective with this particular glass lens. This image is now ready to be printed out and tested with the glass lens.

Bibliography

Text Sources

Agarwal, A. and Blake, A. (2010). *Dense stereo matching over the Panum Band*, IEEE T. Pattern Anal.32.4,16–430

Alberti, Leon Battista, *On Painting* [1435–36], trans. with notes by John R. Spencer [1956] (New Haven, CT: Yale University Press, 1970)

The American Studio Glass Movement, Corning Museum of Glass (October 5th2011), available at: <https://www.cmog.org/article/american-studio-glass-movement> [Accessed 10/07/18]

Analytical Cubism, Tate Gallery, <https://www.tate.org.uk/art/art-terms/a/nalytical-cubism> [Accessed 19/011/19]

Animate, Oxford Dictionaries, <https://en.oxforddictionaries.com/definition/laminate> [Accessed 16/05/19]

Animation Effect, VICGI, <http://www.vicgi.com/animation-effect.html> [Accessed 1/04/19]

Antonova, Clemena, *On the Problem of ‘Reverse Perspective: Definitions East and West*, Leonardo, 43.5 (2010), 464–469

Aristotle, Encyclopedia Britannica Online, available at: <http://www.britannica.com/biography/Aristotle>. [Accessed 22/04/16]

Arnheim, Rudolf, *Visual Thinking* (Berkeley, CA: University of California Press, 1969)

Arnheim, Rudolf, *Art and Visual Perception: a Psychology of the Creative Eye*, rev. ed. (Berkeley, CA: University of California Press, 1974).

Artist Karlyn Sutherland, Bullseye Projects, <https://www.bullseyeprojects.com/artists/419-karlyn-sutherland/overview/> [Accessed 15/10/17]

Aumont, Jacques, *The Image* (London: BFI Publishing, 1997)

Basics: Glass Annealing, Kopp Glass, <http://www.koppglass.com/blog/basics-glass-annealing/> [Accessed 5/4/19]

Bennett, Joseph, *How we made Alexander McQueen’s Kate Moss Hologram*, *Creative Review* (13 March 2015). <https://www.creativereview.co.uk/alexander-mcqueens-kate-moss-hologram/>. [Accessed 10/9/2019]

Berger, John, *Ways of Seeing* (London: Penguin Classics, 1972)

Blumberg, Naomi, *Linear perspective*, Encyclopaedia Britannica Online (2016), available at: www.britannica.com/art/linear-perspective [Accessed 23/05/2016].

Blundell, Barry, *An Introduction to Computer Graphic and Creative 3-D Environments* (London: Springer-Verlag, 2008)

Bourke, Paul, *Autostereoscopic lenticular images*, Paul Bourke (2014), available at: <http://paulbourke.net/stereographics/lenticular/>. [Accessed 7/04/15]

Brewster, David, *The Stereoscope: its History, Theory and Construction* (London: John Murray, 1856)

Exploring the Optical Perception of Image Within Glass

Burckhardt, Christopher, Optimum Parameters and Resolution Limitation of Integral Photography, *Journal of the Optical Society of America*, 58 (January 1968), 71–76

Burton, Harry E., Translation of the Optics of Euclid, *Journal of the Optical Society of America*, 35.5 (May 1943)

Ceramic Transfer, Digital Ceramics Ltd, <http://www.digitalceramics.com/sections/ceramic-transfer.php> [Accessed 10/04/19]

Cheung, Isaac *Lenticular Printing 101: 3D Lenticular Printing Interlacing Algorithm Illustrated Using Photoshop*, ViCGI Lenticular Printing 101, available at: <http://www.vicgi.com/lenticular-interlacing-algorithm.html> [Accessed 6/10/15]

Cherry, Kendra, *Monocular Cues for Depth Perception*, Verywellmind (Nov 2019) <https://www.verywellmind.com/what-are-monocular-cues-2795829>. [Accessed 1/12/19]

Choosing the Correct Lenticular Lens Sheet, Micro Lens Technology, Inc. http://www.microlens.com/pages/choosing_right_lens.htm. [Accessed 12/04/19]

Christensen, Ruth, *Mark Rothko: Art as an Experience: The Significance of Interaction Between Painting and Viewer in the Rothko Chapel*, RIHA Journal 0183 (15 December 2017), available at: <http://www.riha-journal.org/articles/2017/0183-christensen> [Accessed 27/01/20]

Coherence, Encyclopedia Britannica, <https://www.britannica.com/science/coherence> [Accessed 24/10/19]

Convex, Dictionary.com. <http://www.dictionary.com/browse/convex>, [Accessed 20/04/18]

Contessanally, *The Venice Glass Week: Caterina Tognon Gallery*, Jessica Loughlin, September 2017, <http://contessanally.blogspot.com/2017/09/the-venice-glass-week-caterina-tognon.html> [Accessed 15/8/18]

Corning Museum of Glass, *The American Studio Glass Movement*, Published on October 5, 2011. Published on October 5, 2011. <https://www.cmog.org/article/american-studio-glass-movement> [Accessed 10/03/19]

Crystal, Mike, How do Magnifying Glasses Work? *Sciencing*, (April 24th2017), <https://sciencing.com/magnifying-glasses-work-4567139.html> [Accessed 12/10/18]

Da Vinci, Leonardo, *A Treatise on Painting* [c. 1540], trans. John Francis Rigaud, 1742–1810; (London: J.B Nichols and son, 1835)

Decker, Kris, *The Fundamentals of Understanding Colour Theory*, 99 Designs, (2016), <https://99designs.co.uk/blog/tips/the-7-step-guide-to-understanding-color-theory/> [Accessed 12/10/19]

Dempster, Paul, 3D Imaging Technology Changing the Way We Look at Things, *Tech Briefs: Engineering Solutions for Design and Engineering* (Nov 1st2011), available at: <https://www.techbriefs.com/component/content/article/tb/features/articles/11932>. [Accessed 29/03/19].

De Palma, B., *The Responsive Eye* [exh. cat.], (New York: Museum of Modern Art, 1965)

Western Art, Discover Art, Art Gallery of New South Wales, <https://www.artgallery.nsw.gov.au/discover-art/learn-more/western-art/> [Accessed 10/03/19]

Dorland's Medical Dictionary (Philadelphia, PA: Saunders, 2007)

Double vision, *Conditions*, NHS, <https://www.nhs.uk/conditions/double-vision/> [Accessed 21/06/18]

Exploring the Optical Perception of Image Within Glass

Edgerton, Samuel Y. Jr, *Brunelleschi's First Perspective*, *Arte Lombarda* 18. 38/39, 172–195.(1973)

Eliasson, Olafur, quoted in a press release by The Tanya Bonakdar Gallery, *Artsy.net* (March 2017) <https://www.artsy.net/show/tanya-bonakdar-gallery-olafur-eliasson-the-listening-dimension> [accessed 15/08/18]

Empak, Jesse, What is Augmented Reality? *Live Science*: (June 2018), <https://www.livescience.com/34843-augmented-reality.html> [Accessed 10/11/19]

Euclid, Encyclopedia Britannica Online, available at: <http://www.britannica.com/biography/Euclid-Greek-mathematician>. [Accessed 25/05/17]

Florensky, Pavel, *Beyond Vision: Essays on the Perception of Art*, (London: Reaktion Books Ltd, 2002).

Forced perspective, Collins Dictionary, <https://www.collinsdictionary.com/dictionary/english/forced-perspective> [Accessed 12/10/19]

Fry, Roger, *Reflections on British Painting* (London: Ayer,1934).

Funk, Walter, History of Autostereoscopic Cinema, *Proceedings of the SPIE, IS&T Electronic Imaging, Stereoscopic Displays and Applications, XXIII 8288*, (2012), available at: http://www.hologlyphics.com/Autostereoscopic_Cinema_History.pdf. [Accessed 12/8/17]

Garcia, Pablo, *The Lenticular Legacy*, Kickstarter (2013), available at: <http://www.kickstarter.com/projects/sha/gifpop-custom-gif-cards-for-everyone/posts/689960> [Accessed 14/01/14]

Gestalt Laws of Perception, *Verywellmind*, <https://www.verywellmind.com/gestalt-laws-of-perceptual-organization-2795835> [Accessed 19/04/18]

Glossary of Terms, Northstar Glass, <http://northstarglass.com/users-manual/glossary-terms/>. [Accessed 19/04/18]

Gombrich, Ernst Hans, *Art and Illusion: a Study in the Psychology of Pictorial Representation*, 6th ed., (London: Phaidon, 2002).

Gregory, Richard L., *The Medawar Lecture 2001: Knowledge for Vision: Vision for Knowledge*, *Philosophical Transactions: Biological Sciences*, 360. 1458, (2005), 1231–125

Griffith. Mari, *Art History 101: What is Trompe l'oeil?*, Royal Academy of Art (2015), available at: <https://www.royalacademy.org.uk/article/art-history-101-trompe-loeil>. [Accessed 18/04/17].

Hayes, Robert. M, *3-D Movies: History and Filmography of Stereoscopic Cinema* (Jefferson, NC: McFarland & Co, 1989)

Helmenstine, Anne Marie, *Colored Glass Chemistry: How Does it Work?* ThoughtCo. (2017), available at <https://www.thoughtco.com/the-chemistry-of-colored-glass-602252> [Accessed 21/04/18]

Henderson, Tom, Visible Light and the Eye's Response, *Physics Classroom*, available at: <http://www.physicsclassroom.com/class/light/Lesson-2/Visible-Light-and-the-Eye-s-Response>, [Accessed 16/04/18].

Heider, Grace M. More about Hull and Koffka, *American Psychologist*, 32.5 (1977), 383

Hockney, David, *Secret Knowledge: Rediscovering the Lost Techniques of the Old Masters*, new and expanded ed., (London: Thames & Hudson, 2006).

How to apply transfers, *Fotoceramic*, https://www.fotoceramic.com/p/how_to_apply_transfers.php [Accessed 12/4/19]

Exploring the Optical Perception of Image Within Glass

How to Prevent Ghosting, VICGI,

http://www.vicgi.com/How_to_Prevent_Ghosting_20120113.pdf [Accessed 1/04/19]

Hyde, Caitlin, *Transparency & Light in Glass & Art*, Corning Museum of Glass [blog post], (Feb 2015), available at: <https://blog.cmog.org/2015/02/18/transparency-light-in-glass-art/> [Accessed 21/04/17].

Intellect, Lexico. <https://www.lexico.com/en/definition/intellect>. [Accessed 10/8/18]

Interocular Distance, Medical Dictionary, The Free Dictionary,

<https://medical-dictionary.thefreedictionary.com/interocular+distance>

James, Ronald, C. Dalmatian dog, Photograph, *Life magazine*:58;7 (19 February 1965), p 120.

Jarvinen, Jaako.E, Korkala, Pekka Yrjo and others, *Space Perception*, in Encyclopedia Britannica, (May 22nd, 2017.) <https://www.britannica.com/science/space-perception/Visual-factors-in-space-perception> [Accessed 05/04/19]

Jeremy Lepisto, <https://www.jeremylepisto.com/crate-series.html>, [Accessed 15/10/2015]

Johnson, Barry R. and Jacobsen, Garry A. Advances in Lenticular lens arrays for visual display, *Proceedings of SPIE Conference*, Vol. 5874, San Diego (2005), available at: <https://www.spiedigitallibrary.org/conference-proceedings-of-spie/5874/587406/Advances-in-lenticular-lens-arrays-for-visual-display/10.1117/12.618082.short>. [Accessed 5/05/16]

Johnston, Sean. F, *Holographic Visions: A history of new science*, (Oxford: Oxford University Press, 2006)

Johnson, Sean. F., What became of Holography? The Once-futuristic Technology has Less Public Glamour Nowadays, but it Still Plays a Current Role in Science, *American Scientist*, 99.6 (November 2011), 482, available at: <https://www.americanscientist.org/article/whatever-became-of-holography> [Accessed 21/10/19]

Kemp, Martin, *The Science of Art: Optical Themes in Western Art from Brunelleschi to Seurat* (New Haven, CT: Yale University Press, 1992)

Kemp, Martin. *Visualizations: The Nature Book of Art and Science*, (Berkeley, CA; Los Angeles, CA: University of California Press, 2000)

Killian, Jeremy, That Deceptive Line: Plato, Linear Perspective, Visual Perception and Tragedy, *Journal of Aesthetic Education*, 46.2, 89–99, (May 2012)

Koffka, Kurt, *Principles of Gestalt Psychology* (New York: Harcourt Brace, 1935)

Lahanas, Michael, Ancient Greece: Optics, *Hellenica World* (n.d.), available at: <http://www.hellenicaworld.com/Greece/Science/en/Optics.html> [accessed 21/05/15]

Layer, Harold. A. Stereoscopy: Where did it come from? Where will it lead?, *EXPOSURE*, 17.3 (Fall 1979), 34–48, and presented at The National Conference for the Society of Photographic Education, 1979, Fort Worth, Texas, available at: <http://userwww.sfsu.edu/hl/stereo.html> [Accessed 10/5/18]

Lenticular Lenses, Humaneyes (2015) <http://ga.humaneyes.com/learn/lenticular-lenses> [Accessed 15/10/16]

Lenticular Print, Pacur, <https://www.pacur.com/markets/lenticular-print>, (on-line) [Accessed 28/04/19].

Lenticular Printing, MJCP, <https://www.mjcp.co.uk/lenticular-printing>. [Accessed 1/04/19]

Exploring the Optical Perception of Image Within Glass

Lifetiles, Rufus Lifetiles, <http://www.rufuslifetiles.com/about.html> [Accessed 10/08/14]

Linear perspective, [online]. Available at : www.britannica.com/art/linear-perspective. [Accessed 22/04/16].

Locke, John, *An Essay Concerning Human Understanding*, ed. by P. H. Nidditch (Oxford: Clarendon Press, 1975)

Lost Wax Kiln Casting, Bulls Eye Glass, <https://www.bullseyeglass.com/methods-ideas/tipsheet-8-basic-lost-wax-kilncasting.html> [Accessed 1/04/19]

McCarthy, Tom, *Blurred visionary: Gerhard Richter's photo-paintings*, *The Guardian*, 22nd Sep 2011, available at: <https://www.theguardian.com/artanddesign/2011/sep/22/gerhard-richter-tate-retrospective-panorama> [Accessed 10/02/15]

McGorlick, Ashleigh, *Double Vision (Diplopia): Causes, Symptoms and Treatment*. *Eye5*, 23 Oct 2015. (online). <https://eye5.com.au/eye-care/diplopia-double-vision/> [Accessed 15/10/18]

Macknik, Stephen, and Martinez-Conde, Susan, *Sights of Mind: What the Neuroscience of Magic Reveals about Our Everyday Deceptions* (New York: Henry Holt and Co., 2010)

Magritte Foundation, <https://www.renemagritte.org> [Accessed 20/09/19]

Mannoni, Laurent, *Eyes, Lies and Illusions: The Art of Deception* [exh. cat.] (London: Hayward Gallery, 2004).

Mansurov, Nasim, *What is Bokeh? Photography Life* (11th July 2018), available at: <https://photographylife.com/what-is-bokeh> [Accessed 19/04/17].

Martin, J., *The Renaissance World* (Abingdon: Routledge, 2007).

McCormick, Malcolm. and Yang, Li. Three-dimensional Imaging Systems: a New Development, *Applied Optics*, 27, 4520–4528 (1988)

Met Museum Bulletin, *Modern Art*, Metropolitan Museum of Art, New York <https://www.metmuseum.org/pubs/bulletins/1/pdf/3269174.pdf.bannered.pdf> [Accessed 20/07/19]

Mills, H.N, Use of Fining Agents, in :William J. Smothers, *Ceramic Engineering and Science Proceedings* (American Ceramic Society, 1986) <https://ceramics.onlinelibrary.wiley.com/doi/10.1002/9780470320327.ch7> [Accessed 25/09/18]

More about Peppers Ghost, *TheatreCrafts.com*, <http://www.theatrecrafts.com/pages/home/glossary-of-technical-theatre-terms/more-about-peppers-ghost/> [Accessed 20/01/20]

Morph Effect, *VICGI*, <http://www.vicgi.com/morph-effect.html> [Accessed 1/04/19]

Neate, Hannah, and Joanna Pready, *Space, Place and Landscape*, workshop, Nottingham University (July 2007), available at: <https://www.nottingham.ac.uk/cas/documents/landscapes/onlineintrofinalversion.pdf> [Accessed 3/02/18]

Necker Cube, *The Illusion Index*, <https://www.illusionsindex.org/ir/necker-cube> [Accessed 03/12/15]

Novella, Stephen, *Monocular Depth Perception*, *Neurologica* [blog](March 2008), available at: <https://theness.com/neurologicablog/index.php/monocular-depth-perception/> [Accessed 25/08/19]

Ogle, K. N. *Researches in Binocular Vision*. (New York: Hafner Publishing Company, 1964)

Exploring the Optical Perception of Image Within Glass

Okoshi, Takanori. *Three-Dimensional Imaging Techniques* (New York: Academic Press, 1976)

Op Art Movement Overview and Analysis, The Art Story (2017), available at: <http://www.theartstory.org/movement-op-art.htm> [Accessed 18/04/17]

Orton, Edward. Jr, *Orton Firing Tip: Firing Red Glazes*, Laguna Clay, <http://www.lagunaclay.com/support/orton-firing-redglazes.php> . [Accessed 12/04/19]

Optical illusion, Cambridge Dictionary, <https://dictionary.cambridge.org/dictionary/english/optical-illusion>)

Parallax, Oxford Dictionaries, <https://en.oxforddictionaries.com/definition/parallax> [Accessed: 12/04/19]

Pepperell, Robert and Anja Ruschkowski, *Double Vision as a Pictorial Depth Cue*, *Art & Perception* 1.1 (Feb 2013), 49–64

Phoenix, Sarah, *Binocular Cues: Definitions and Example*, Study.com, <https://study.com/academy/lesson/binocular-cues-definition-examples.html>. [Accessed 12/10/19]

Plato, Encyclopedia Britannica Online, available at: <http://www.britannica.com/biography/Plato>. [Accessed 22/04/16].

Pliny (the Elder), *The Natural History, Book XI* (Cambridge, MA: Harvard University Press, 1975)

Plummer, Barry, *Evan Walters: Moments of Vision*. (Wales: Seren publishing, 2011)

Proffitt, Dennis. R. and Corrado Caudek, *Depth Perception and the Perception of Events*, in *The Handbook of Psychology*, ed. by Irving Weiner (Hoboken, NJ: John Wiley & Sons, 2003)

Prokopenko, Stan, *The Illusion of Depth, Contrast, Aerial Perspective and Form*, *Proko* (April 6 , 2013), available at: https://www.proko.com/illusion-of-depth-contrast-aerial-perspective-form/#.XePFmC2cb_Q. [Accessed 20/04/17]

Pseudoscopic Image, The Free Dictionary, <https://encyclopedia2.thefreedictionary.com/pseudoscopic+image>

Ptolemy, Encyclopaedia Britannica, <https://www.britannica.com/biography/Ptolemy> [Accessed 06/12/19]

Reflection, Cambridge Dictionary, <https://dictionary.cambridge.org/dictionary/english/reflection>

Refraction, Oxford Dictionaries, <https://en.oxforddictionaries.com/definition/refraction>. [Accessed 19/04/18]

Roberts, David E., *History of Lenticular and related Autostereoscopic Methods* (Hillsboro, WI: Leap Technologies, 2003), available at: http://archiviostereoscopicoitaliano.it/documenti/history_of_lenticular.pdf. [Accessed 10/09/15]

Roberts, David. E., *History of Lenticular, Lenstar Lenticular* (n.d.), available at: <https://www.lenstarlenticular.com/history-of-lenticular> [Accessed 06/09/2015]

Rouse, Margaret, *Stereoscopy (stereoscopic Imaging) Whatis* (2013), available at: <http://whatis.techtarget.com/definition/stereoscopy-stereoscopic-imaging> [Accessed: 10/12/2013]

Sarmiento, Jeffrey, *Graphic Glass: Development of Creative Approaches to Expressions of Ethnicity*. (Unpublished PhD thesis, University of Sunderland, 2011)

Exploring the Optical Perception of Image Within Glass

Schwoere, Daniel. W, *Compatibility of Glasses, COE Does Not Equal Compatibility*, Bullseye Glass Co.
https://www.bullseyeglass.com/images/stories/bullseye/PDF/TechNotes/technotes_03.pdf.
[Accessed 1/04/19]

Scott, Paul, *Ceramics and Print: Historical and Industrial Background*, 2nd. ed. (London:A&C Black, 2002)

Searle, Adrian, If you go down to the woods today, *The Guardian* (3 October 2000)
<https://www.theguardian.com/culture/2000/oct/03/artsfeatures>,
[Accessed 13/04/17]

Selected Works for the Watertower series, Jeremy Lepisto,
<https://www.jeremylepisto.com/watertower-series.html>, [Accessed 15/10/2015]

Serbena, Francesca, Zanotto, Edgar. D, Internal Residual Stresses in Glass-ceramics: a Review, *Journal of Non-crystalline Solids*, 358.6–7 (April 2012), 975–984.
<https://www.sciencedirect.com/science/article/pii/S0022309312000555>. [Accessed 12/04/19]

Skaalid, Bonnie, *Gestalt Principles: Closure, Area and Symmetry*, University of Saskatchewan,
<https://etad.usask.ca/skaalid/theory/gestalt/closure.htm>. [Accessed 19/01/18].

Soegaard, Mads, *Laws of Proximity, Uniform Connectedness and Continuation: Gestalt Principles 2*, Interaction Design Foundation, <https://www.interaction-design.org/literature/article/laws-of-proximity-uniform-connectedness-and-continuation-gestalt-principles-2>
[Accessed 19/01/18]].

Solso, Robert and Judith E. McCarthy, Prototype formation of faces: A case of pseudomemory, *British Journal of Psychology*, 72.4 (1981), 499–503

Sprues, flash and runners explained, MRT Castings, <https://blog.mrt-castings.co.uk/blog/sprues-flash-and-runners-explained>. [Accessed 1/04/19]

Steinmeyer, Jim, *Two Lectures on Theatrical Illusion* (Burbank, CA: Hahne 2001)

Stephenson, Andrew, *Kant's Theory of Experience* (Unpublished PhD thesis, University of Oxford, 2013), available at:https://ora.ox.ac.uk/objects/uuid:12e951eb-8eef-4112-b90d-52e7d4fe6251/download_file?file_format=pdf&safe_filename=THESIS01&type_of_work=Thesis [Accessed 21/12/18].

Stereoscopic Imaging, Techopedia,
<https://www.techopedia.com/definition/91/stereoscopic-imaging> [Accessed 19/12/17]

Studio glass, Dictionary.com. <https://www.dictionary.com/browse/studio-glass> [Accessed 21/10/2017]

Tatarchuk, Natalya, Visual Indeterminacy: Art, Science, Philosophy, based on Robert Pepperell, *Seeing Without Objects: Visual Indeterminacy and Art*, Leonardo, 39.5 (October 2006), 394–400

Theodor, *Reverse Perspective in Christian Iconography*, The Peacocks Tail: Essays on Mathematics and Culture.[blog] (April 27th2011),
<https://pavlopoulos.wordpress.com/2011/04/27/reverse-perspective-in-christian-iconography/>, Online, [Accessed 10/08/19].

The Ponzo Illusion, *Illusions index*, <https://www.illusionsindex.org/i/ponzo-illusion> [Accessed 25/01/20]

Exploring the Optical Perception of Image Within Glass

Timmons, Jessica, *When do newborn babies start to see?* Healthline (August 2016), <https://www.healthline.com/health/parenting/when-do-newborns-start-to-see#Your-babys-sight:-newborn-to-4-months> [Accessed 21/09/18]

Tyler, Christopher, *Perspective as a geometric tool that launched the Renaissance*, in Proceedings of SPIE – The International Society for Optical Engineering (June 2000), 10.1117/12.3872092000

Tyley, Jodie, *The Science of Vision: How do our Eyes See?* *Independent*, 23 September 2015, available at: <https://www.independent.co.uk/life-style/health-and-families/features/the-science-of-vision-how-do-our-eyes-see-10513902.html> (Accessed 15/01/16)

Vernon, Michael D., *Perception Through Experience* (London: Routledge, 1970)

Virtual – (Within Computing), <https://www.lexico.com/en/definition/virtual> [Accessed 1/04/19]

Wade, Nicolas. J. (ed.) *Brewster and Wheatstone on Vision* (London: Academic Press, 1984)

West, Louise J, von Fieandt, Kai V.J, et al, *Visual Factors in Space Perception*, Encyclopedia Britannica, (May 2017)
<https://www.britannica.com/science/space-perception/Visual-factors-in-space-perception> [Accessed 10/09/19]

What Is a Tunnel Book?, Wonderopolis, <https://wonderopolis.org/wonder/what-is-a-tunnel-book>. [Accessed 19/05/18]

What is Lenticular? Virtual Images, <http://www.virtual-images.com/what-is-lenticular> [Accessed 1/04/19]

Western Art, Discover Art, Art Gallery of New South Wales, <https://www.artgallery.nsw.gov.au/discover-art/learn-more/western-art/> [Accessed 10/03/19]

Wilder, Fred, *Anaglyph 3D Know How*, Fred Wilder Studios, <http://stcroixstudios.com/wilder/anaglyph/whatsanaglyph.html>. [Accessed 10/03/19]

What Is a Tunnel Book?, Wonderopolis, <https://wonderopolis.org/wonder/what-is-a-tunnel-book>. [Accessed 19/05/18]

Wittkower, Rudolf, and B.A.R. Carter, *The Perspective of Piero della Francesca's Flagellation*, *Journal of the Warburg and Courtauld Institutes*, 16. 3/4 (1953), 292–302

Wonseok Koh, *Dimensions, Reinoud Oudshoorn*, [exh.cat] (Korea: Arko Art Centre, 2012).

Woodford, Chris, *Lenses*, *Explainthatstuff!*, <https://www.explainthatstuff.com/lenses.html> [Accessed 25/04/19]

Zeki, Semir, *Art and the Brain*, *Daedalus*, 127.2 (1998), 71–103
<http://www.vislab.ucl.ac.uk/pdf/Daedalus.pdf> [Accessed 21/09/14]

Zeki, Semir, *Inner Vision: An Exploration of Art and the Brain*, (Oxford: Oxford University Press, 2000)

Films

Reverspective [Video], dir. by Jake Auerbach and Michael Houldey (1997)
VHS, England. (1997)

