

## Life-cycle analysis of the total danish energy system

Kuemmel, Bernd; Sørensen, Bent; Nielsen, S

*Publication date:*  
1997

*Document Version*  
Publisher's PDF, also known as Version of record

*Citation for published version (APA):*  
Kuemmel, B., Sørensen, B., & Nielsen, S. (1997). *Life-cycle analysis of the total danish energy system*. Roskilde Universitet. Tekster fra IMFUFA No. 334 <http://milne.ruc.dk/lmfufaTekster/>

### General rights

Copyright and moral rights for the publications made accessible in the public portal are retained by the authors and/or other copyright owners and it is a condition of accessing publications that users recognise and abide by the legal requirements associated with these rights.

- Users may download and print one copy of any publication from the public portal for the purpose of private study or research.
- You may not further distribute the material or use it for any profit-making activity or commercial gain.
- You may freely distribute the URL identifying the publication in the public portal.

### Take down policy

If you believe that this document breaches copyright please contact [rucforsk@ruc.dk](mailto:rucforsk@ruc.dk) providing details, and we will remove access to the work immediately and investigate your claim.

## LIFE-CYCLE ANALYSIS OF THE TOTAL DANISH ENERGY SYSTEM

An assessment of the present Danish energy system and selected future scenarios

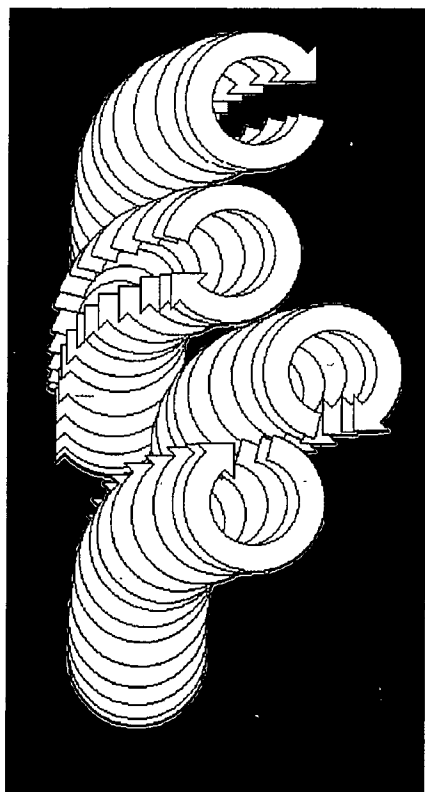

**Bernd Kuemmel and Bent Sørensen**

INSTITUTE 2  
ENERGY & ENVIRONMENT GROUP

with a contribution from Stefan Krüger Nielsen

31. January 1997

Final report for a project in the Danish Energy Research Programme EFP-94,  
funded by the Danish Energy Agency under contract no. 1753/04-0001

**TEKSTER fra**

**IMFUFA**

**ROSKILDE UNIVERSITETSCENTER**  
INSTITUT FOR STUDIET AF MATEMATIK OG FYSIK SAMT DERES  
FUNKTIONER I UNDERVISNING, FORSKNING OG ANVENDELSER

ROSKILDE UNIVERSITY, P.O.BOX 260, DK-4000 ROSKILDE, DENMARK.  
TEL: (+45) 4675 7711, FAX: (+45) 4675 5065, EMAIL: BES@RUC.DK  
INSTITUTE OF STUDIES IN MATHEMATICS AND PHYSICS, AND THEIR FUNCTIONS  
IN EDUCATION, RESEARCH AND APPLICATION.

31. January 1997

LIFE-CYCLE ANALYSIS OF THE TOTAL DANISH ENERGY SYSTEM

by Bernd Kuemmel, Bent Sørensen, with a contribution by Stefan Krüger Nielsen

IMFUFA text no. 334, 213 pp

ISSN0106 6242

**Abstract** - The present report discusses the methodology for performing system-wide life-cycle analyses in the energy field, and applies the selected methodology to the current Danish system as well as to two scenarios that have been proposed for a possible development during the next century, aimed at removing any Danish contribution to additional greenhouse warming.

On the methodology issue, we present two major findings: One is that the conventional chain analysis used in product life-cycle analysis causes a serious risk of double counting. One may say that including indirect impacts is fine as long as they come from activities outside the limits of the analysis, but if they are taken into account elsewhere in the analysis, one should add direct impacts on a component-by-component basis, and omit indirect contributions. In practice there may be compromises to be made, as the system-wide analysis may include all components of the energy system, but not other parts of the economic system (e.g. agriculture delivering manure to biogas plants). The only clear cases are that of a single product or that of the entire economy. Anything "in-between" calls for careful removal of double counting, often on a process by process basis.

The other methodology issue is that we have identified two accounting principles, which from a technical point of view are equally justified: One is the economy point of view, where all impacts produced by activities within the Danish economy are enumerated, but where impacts incurred by production of materials imported into the Danish economy are omitted (and considered part of the impacts from the total economy of the exporting country). The other is the product point of view, where impacts from imported goods are included in the Danish load, but impacts associated with our exports not. We think these two views are already underlying some of the discussions in the international greenhouse debate. From practical considerations, the calculations for the economy point of view can be performed with much higher accuracy than the other kind, because it is difficult for us to access the environmental impacts from mining or the work environment issues for distant countries lacking proper statistics. We are able to give numbers evaluated according to both principles and offer them as input to further discussion of this point.

The total impacts of the present Danish energy system has been calculated in what we believe is the first consistent national evaluation, where in contrast to earlier work by e.g. the European Commission, we use Danish emission data, dispersion conditions, population densities and take into account the specificities of the Danish energy system, such as the high degree of combined heat and power production.

As regards the future scenarios, there is more uncertainty because many of the assumed technologies are at present emerging, and it is difficult to estimate impacts what would be valid for the mature technology finally used. We have probably been too conservative in our technology forecasts, but even so, it is clear that both the renewable energy based scenarios lead to substantially lower impacts than the present system - which is of course in line with the very reasons for suggesting these scenarios.

# **LIFE-CYCLE ANALYSIS OF THE TOTAL DANISH ENERGY SYSTEM**

**An assessment of the present Danish energy system and selected future scenarios,  
based on methods developed in several international projects:**

Organisation for Economic Co-operation and Development (Life-cycle Methodology workshop)  
International Energy Agency (Scoping study and comparative assessment study)  
Japanese Ministry of Industry, Trade and Innovation (Energy technology assessment study)  
European Commission (JOULE II project Externalities of Energy)  
Danish Technology Council (Energy futures project)  
European Commission (RENA project Long-term Integration of Renewable Energy)  
Intergovernmental Panel of Climate Change (Second Assessment Report on Mitigation)

**Bernd Kuemmel and Bent Sørensen**  
with a contribution from Stefan Krüger Nielsen

Roskilde University, Institute 2 (IMFUFA), Energy & Environment Group  
P. O. Box 260, DK-4000 Roskilde, Denmark

**FINAL REPORT**  
for a project in the Danish Energy Research Programme EFP-94,  
funded by the Danish Energy Agency under contract no. 1753/94-0001



# LYFE-CYCLE ANALYSIS OF THE TOTAL DANISH ENERGY SYSTEM

BERND KUEMMEL and BENT SØRENSEN

with a contribution from Stefan Krüger Nielsen

## TABLE OF CONTENTS

<b>Preface.....</b>	<b>2</b>
<b>1. Introduction.....</b>	<b>3</b>
<b>2. LCA methodology.....</b>	<b>7</b>
<b>3. Scenario choices.....</b>	<b>16</b>
<b>3.1 Present energy system.....</b>	<b>16</b>
<b>3.2 The ecologically sustainable scenario.....</b>	<b>20</b>
<b>3.3 The fair market scenario.....</b>	<b>26</b>
<b>4. Selecting data for the life-cycle analysis.....</b>	<b>41</b>
<b>4.1 Impact types included.....</b>	<b>42</b>
<b>4.2 Pathway calculations.....</b>	<b>46</b>
<b>4.3 Monetising the impacts.....</b>	<b>47</b>
<b>4.4 Specific LCA data used.....</b>	<b>49</b>
<b>4.5 Chain analysis of selected energy supply options.....</b>	<b>62</b>
<b>5. Model results.....</b>	<b>73</b>
<b>5.1 Overall results of LCA model calculations.....</b>	<b>74</b>
<b>5.2 Discussion of detailed results.....</b>	<b>76</b>
<b>6. Conclusions.....</b>	<b>82</b>
<b>Literature.....</b>	<b>84</b>
<b>List of units and conversion factors.....</b>	<b>105</b>
<b>Appendix A: Technology descriptions.....</b>	<b>107</b>
<b>Appendix A: Table of contents.....</b>	<b>185</b>
<b>Appendix B: Efficiency of energy use for transportation of persons in Denmark.....</b>	<b>188</b>
<b>Appendix B. Literature.....</b>	<b>208</b>

## Preface

The project described in this report has been performed within the Danish Energy Agency Research Programme. It is partly an implementation of the European Commission JOULE project, partly a further development of methodology and assessment. The project period has been from early 1994 to end of 1996, which has made it possible to utilise all the other projects listed, as their final report dates range from 1992 (OECD project) to mid-1996 (RENA project). Bent Sørensen has been a lead author in all the projects listed, and Bernd Kuemmel and Stefan Krüger Nielsen has similarly worked on the RENA project. The scenarios of two future examples of possible Danish energy systems used in the present work are taken from a Danish Technology Council project and from the RENA project, where they are one of several scenarios considered. The Technology Council scenario used was in the original report called the "dark green scenario", reflecting its underlying ecological value system. We shall refer to it as the "ecologically sustainable scenario". It considers Denmark in isolation, with full self-sufficiency of energy supply. The other scenario based on the RENA project is called the "fair market scenario", as it assumes market mechanisms to determine the development, except that current externality costs are to be included in any technology choices (hence a "fair" market). The RENA project constructs a scenario for the 15 current EU member states, and the Danish part of the scenario is characterised by substantial amounts of energy exchange and trade with neighbouring countries.

All the other projects have been contributing to life-cycle methodology and assessment, from the early LCA for energy systems methodology paper written for the OECD to recent work for UN's Climate Panel. Central among the externality studies is the JOULE II ExternE study, which is the most recent detailed bottom-up study of energy-cycle externalities for selected energy chains, and focusing on health and pollution impacts. In the case of externalities for fossil energy systems, the greenhouse warming impacts are expected to be very important, but ExternE only contains a literature review. More may be forthcoming in phase 3 of ExternE (due late 1997, with Bernd Kuemmel and Bent Sørensen participating), but for the purpose of the present study, a dedicated externality evaluation of the greenhouse warming impacts has been independently performed, based on the IPCC Second Assessment identification of physical impacts. The combination of insights obtained in a large number of independent studies have allowed the present work to attain a state-of-the-art level. That could not have been achieved at the present time where reports from the various projects are first appearing, without our actual involvement in the projects and access to working material. We want to express our appreciation of many good discussions with partners in the projects mentioned.

file: [TT]d:projekter\EFP-94\final\EFPch1.doc

## 1. INTRODUCTION

The promise of life-cycle analysis (LCA) is to enable the incorporation of environmental and social impacts into decision-making processes. The challenge is to do it on the basis of the always incomplete and uncertain data available, in a way that is sufficiently transparent to avoid that the modeller introduces any particular bias into the decision process, by the way of selecting and treating the incomplete data.

The use of LCA for decision-making implies that the object of investigation is not yet implemented, but that more than one option appear to be possible, either with differences in technology used or differences in the way a given technology is produced and used. The life-cycle analysis of the currently existing system - which we will do for a start - is thus to be seen as a reference, against which alternative solutions to the same problem is weighed. However, as it takes time to introduce new systems, the alternative scenarios are for a future situation, which is chosen as the middle of the 21st century. The reason for using a 30-50 year period is a reflection on the time needed for a smooth transition to an energy system based on sources different from the ones used today, with implied differences all the way through the conversion and end-use system. This takes time not only due to the requirements of the physical implementation, but also because we assume that no component of the existing system is prematurely scrapped. By "prematurely" we mean that a component should normally not be discarded at a time where the capital cost outlays have not been recuperated. More specifically, it should not be scrapped, unless there is a clear economical advantage in doing so. This could happen at an early stage, if the cost of operating the system were very high as compared to the initial capital cost, but unless fuel prices are to jump up (as they did in 1973/4 and 1979), most equipment is better left operating until the end of its economic depreciation period, and in some cases to the (likely longer) physical life time is exhausted. Typical lifetimes of currently used energy conversion equipment is 10-15 years for some industrial equipment, cars, electronics and appliances, 25-30 years for power plants and certain other industrial equipment, and 50-100 years for basic building structures (although renovation will take place during the lifetime). The choice of a 30-50 year scenario horizon thus ensures that most energy handling equipment can be assumed to be replaced (with what the scenario prefers) in a natural process, that is without additional retirement costs. Only certain buildings will have to be treated separately, with premature retirement or acceptance of sub-standard performance (despite retrofits) as a choice depending on a weighing of other (non-energy) qualities of the building.

The use of future scenarios is likely to yield a more interesting input to the political energy debate than considering only those changes that may evolve by successive, marginal changes of the present system. In fact, it is by no means certain that marginal optimisation (which may

be performed by using the product-LCA method as opposed to the system-LCA) will ever lead to the solutions, that are optimal in the long run. But strictly speaking, there is no guarantee that the scenario method will do this either, because in principle there are infinitely many possible future scenarios, and we select to analyse just a selected few. Our reply would be that the scenarios selected for closer inspection should not just be based on the preferences of the researcher, but should reflect trends visible in the social debates of the society in question, and if the scenario work includes the main visions held by a given society, then it is also relevant to assess the impacts of this limited set of scenarios. A scenario will only be selected if it has been identified and if there is social support for it, so construction of more exotic scenarios by the researcher would only be meaningful, if its advantages are so convincing that an interest can be created and the necessary social support be forthcoming. One may say that the energy scenarios based on renewable energy sources are in this category, as they were identified by a minority group (of scientists and other individuals) and successfully brought to the attention of the public debate during the 1970ies, notably in connection with the anti-nuclear sentiment (see e.g. Sørensen, 1975, 1981 and 1995). In any case it should be kept in mind, that no claim of having identified the optimum solution can be made after assessing a finite number of scenarios.

We start our presentation by giving in Chapter 2 a few highlights of the history of LCA. This will include a discussion of some caveats in applying the methodology, highlighted by outlining the differences between product-LCA and system-LCA. Product-LCA originated in the soft-drink industry and has later been taken up by the chemical industry, recently with detailed guidelines mapped out by the organisation SETAC (Society of Environmental Toxicology and Chemistry; Consoli et al. 1993). A different development has been taking place within the field of energy system analysis, but in most cases using a primary chain of transformation (production steps) similar to that employed in product LCA, including side-line processes of producing equipment and materials for the main chain of conversions. Many of the early studies considered the end-product of "electricity" and its associated fuel chain, and no attempts were made to study the impacts on a system level, incorporating both impacts from manufacture and primary conversion steps but also in subsequent steps all the way to the final consumer's use of the energy for manufacturing a product or performing an activity. Including the end-user in the system allows substitution of different solutions (both as regards energy use and non-energy related processes, cf. Sørensen 1982, 1996) and thus a more relevant type of optimisation than the mere choice of conversion equipment, but it also introduces problems of double-counting, if the system impacts are summed up without regard to the loop effects of end-uses being inputs to previous conversion steps.

A very important issue discussed in Chapter 2 is the handling of import and export of energy and other commodities. Here are really two radically different ways of proceeding: Either all impacts due to activities outside the study area (e.g. country) are ignored, and all inside the study area included, or the impacts of imported goods are calculated at their place of origin,

and the impacts of goods exported are ignored. Both procedures are consistent but are shaped to answer different questions: Are we interested in the impacts of running our country in an environmentally acceptable way (with an export industry to earn foreign currency for imports considered necessary), or are we back at the product level trying to fairly enumerate all the impacts associated with producing a given commodity, thus identifying a "moral commitment" to be considered by the user of the product in question.

In section 3, the selection of future scenarios are presented, along with a discussion of the way to conveniently represent energy use data. Current statistical sources often divide the energy uses on the economic sectors of society, where we need a more specific description of the end-use, in order to be able to assess the possible improvements in conversion efficiency, or the substitution of alternative ways of satisfying the same demand. For some sectors, we have been able to rearrange the data in this way, exhibiting energy form and type of equipment for the final use, but for other sectors, this has involved fairly uncertain estimates of the current distribution. For the future scenarios, the demand development may be simply described in the "right" terms from the beginning, so that the scenario assumptions about future economic activity directly translates into the corresponding energy demand. This method is used in the ecologically sustainable scenario, whereas for the fair market scenario, we have had to go deeper into the scenario description in order to extract the relevant information.

The technologies in use in the scenario futures are described in Chapter 4 and in appendices. Each technology is only discussed briefly, with emphasis on assumed improvements over present state of the art, as there are many detailed technology descriptions available in the literature. However, the description of the technology has to include a listing of the main materials used in manufacture and use, as well as energy inputs for these steps, in order to enable a LCA of the environmental and social impacts. We present the assumed impacts and their causes for each technology, being careful to state the choice made in cases, where different LCA data are found in the literature, and to mark those technologies, for which we think that no proper LCA data exist. This is then a reminder for further need for performing bottom-up LCA's in the future. At the same time, we may be able to estimate the uncertainty associated with our top-down approach, which substitutes average values for impacts from material's provision and usage steps in cases where precise data are not available.

Chapter 5 combines the data presented in Chapter 4 for the present Danish energy system and the two future scenarios, including a discussion of an effort to avoid possible double counting arising from the different levels of indirect impacts included in the literature LCA data for individual processes. Our primary method has been to initiate the conversion chains at the end-user, and to work backwards from there. The possible double counting thus arises when some of the end-use activities have been included as indirect activities at an earlier step. To avoid including impacts twice, we then exclude from the end-uses those associated with the energy sector (refineries, wind turbine manufacturers etc.), in order to reflect the explicit

treatment of this sector and retain the indirect impacts associated with other sectors of the economy not modelled explicitly.

Finally, in Chapter 6 we draw some conclusions, point out where we think current data are insufficient, and discuss how the decision-maker may best use our results. It is clear that the study of a future as distant as fifty years ahead is not to be regarded as a prognosis, but is aimed at influencing the decisions taken today. Because of the inertia of the energy system, decisions about change of direction must be taken many years before the new system will be in place. This emphasises the need for system solutions to be resilient towards changes in future conditions relative to those assumed in the scenarios, or to technology developments differing from those assumed, which are clearly much more likely than the technology assumptions based on present knowledge.

## 2. LCA METHODOLOGY

The first consideration in formulating a life-cycle assessment strategy is to formulate the purpose of the analysis. Several uses may be contemplated:

- a: to determine impacts from different ways of producing the same product.
- b: to determine impacts from different products serving the same purpose.
- c: to determine all impacts from a sector of the economy, such as the energy sector.
- d: to determine all impacts from the entire social system and its activities.

The present investigation aims at item c. The course of the actual investigation may employ different types of analysis:

- A: Chain analysis (with side chains).
- B: System level analysis (each device treated separately).
- C: Partial system analysis (e.g. confined to energy sector).

In a chain analysis (A), impacts caused by provision of sideline inputs (cf. Figure 1) are allocated to the chain investigated by the fraction of production entering the chain. For example, if the equipment used in a chain step such as an oil refinery is provided by a manufacturer, which sells 20% of his production to the oil refinery, then 20% of each of his impacts (environmental, social) are allocated to the oil refinery.

In the system level analysis (B), the impacts from each device in the system is calculated separately and summed up in the end. For example, the direct impacts from running the oil refinery is calculated, and the direct impacts of the equipment manufacturer likewise, as well as any inputs he may receive from other actors. At the end, summing up all the calculated impacts will provide a true total without double counting.

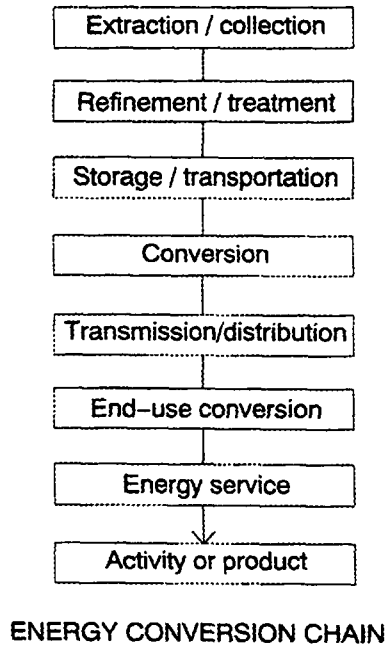

Figure 1a. Generic energy chain

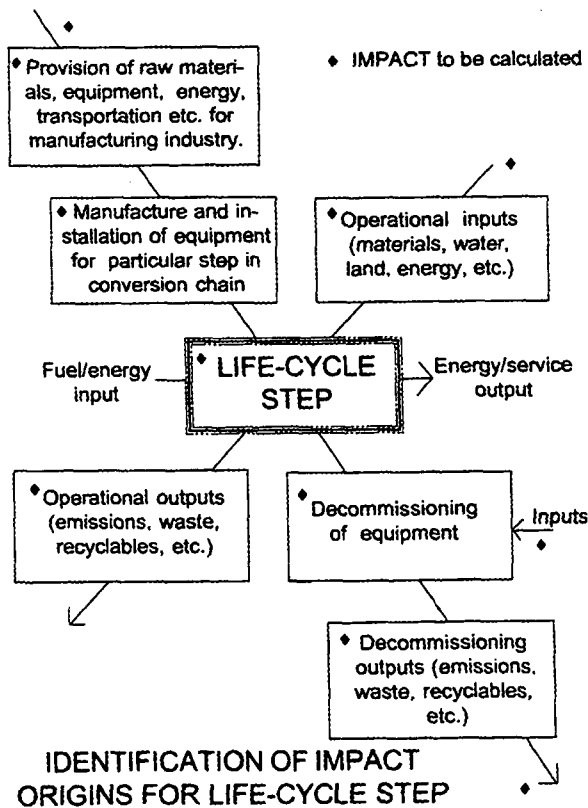

Figure 1b. Input and output streams for a particular life-cycle step.



Our analysis is a partial system analysis (C), in which the energy sector is treated directly, but other sectors of the economy indirectly. Therefore, we must calculate impacts individually according to the system level scheme B for the components of the energy system itself, whereas input of equipment from other sectors are to be evaluated as products, with their imbedded impacts from other actors included. A double counting problem arises, when the imbedded impacts include energy use by one of the manufacturers or other actors not treated explicitly. Since we are treating all steps of the energy conversion chain directly, the impacts from such inputs should be excluded from the indirect side-chains outside the energy sector. In many cases, this distinction is easy to make, because the impacts found in the literature are normally divided into direct and indirect, and the indirect ones distributed over their origin, such as from energy use or other materials use. There are, however, cases in which the data do not allow a precise splitting of the energy and non-energy inputs. In such cases we have had to estimate this split.

An alternative would be to accept the indirect inputs, whether they are energy-related or not. In that case, one would instead have to exclude those energy uses from the end-use list, which have already been included as indirect energy inputs at an earlier stage. This would normally involve more work and a higher uncertainty, because each industry and activity in society would have to be analysed in a depth not normally supported by current statistics, in order to determine the fraction of industrial products and social activities that have been counted at an earlier stage. We have not systematically followed this road, but have in specific cases omitted double counting by excluding end-use impacts when energy input impacts were already included. In other cases the effect of double counting was deemed so small that no corrections were made. More discussion of these cases may be found in Chapter 5.

Many of the available data sources include indirect impacts based on an assumed mix of materials and labour input, taking into account the specific location of production units, mines, refineries etc. This means that an attempt has been made to trace back the origin of all ingredients in a specific product (such as electricity) in a bottom-up approach, which is suited for comparison of different ways of furnishing the product in question (e.g. comparing wind, coal and nuclear electricity).

In our case of an analysis of an entire energy system, the data for specific sites and technology, as well as specific countries from which to import, are not the best suited. Especially for the future scenarios, it seems improper to use data based on the current location of mines, refineries and other installations. One may of course average over many different sets of data, in order to obtain average or "generic" data, but the selection of future energy systems should not depend sensitively on where our utilities choose to purchase their coal this particular year, and therefore a different approach has to be found.

One consistent methodology is to consider the energy system of e.g. Denmark a part of the national economy, such that if we choose to produce more energy than needed domestically in order to export it, this constitutes an economic activity no different from producing more Lego blocks than can be used by Danish children. The exports are an integral part of the

economy of a small country such as Denmark, because we cannot and do not produce every item needed in our society, and thus must export some goods in order to be able to import other ones that we need. Seen in this way, if it is "our own fault", if our exports turn out to have more environmental side-effects than our imports have in their country of origin, and the total evaluation of impacts should simply include those generated as part of the Danish economy, whether for domestic consumption or export. Likewise, the impacts of goods imported should be excluded from the Danish evaluation, except of course for impacts incurred during the operation or use of the imported items in Denmark (such as burning of imported coal)\*.

A consistent methodology is thus to include all impacts of energy production and use in Denmark, but to exclude impacts inherent in imported energy. Since Denmark is about neutral with respect to energy imports and exports (this varies from year to year, but currently, oil and gas exports roughly balance coal imports), the impact calculation for the present system may not turn out so differently from one based on the impacts at the place of production. However, for future systems, this could be very different, because the impacts of renewable systems are chiefly through the conversion equipment, which consists of concrete, metals and other materials, of which 30-50% may be imported. The arguments against confining externality calculations to impacts originating within the country is, that this could lead to purchase of the most environmentally problematic parts of the system from countries paying less attention to the environment than we claim to do. Countries in the early stages of industrial development have a tendency to pay less attention to environmental degradation, making room for what is negatively termed "export of polluting activities to the third world". The counter argument is that this may be better for the countries involved than no development, and that when they reach a certain level of industrialisation, they will start to concern themselves with the environmental impacts (examples Singapore, Hong Kong). Unfortunately, this does not seem universally valid, and the implication of environmental neglect in countries like China, India and South American nations extend outside their borders, as e.g. is the case for global warming, which is not confined to the country of origin or its close regional neighbours. Still, from a methodological point of view, the confinement of LCA impacts to those associated with activities in one country does provide a fair picture of the cost of any chosen path of development, for industrialising as well as for highly industrialised countries.

The problem is that a large volume of existing data is based on the other methodology, where each energy form is viewed as a product, and impacts are included for the actual pathway from mining over refining and transformation to conversion, transmission and use, with the indirect impacts calculated where they occur, that is in different countries. In actuality, the difficulty in obtaining data from some of the countries involved in the early stages of the energy pathway has forced many externality studies to use data "as if" the mining and refining stages had occurred in the country of use. E.g. the ExternE study (European Commission, 1995c) uses coal mined in Germany or England, based on the impacts of mining in these countries, rather than the less known impacts associated with coal mining in the major mining

---

\* The current energy statistics used include energy used by export industries except the oil and gas extraction industries.

countries. Thus the transfer of existing data with specific mining sites to our system or future scenario assessment will also involve serious problems and inaccuracy. It has been pointed out, that this approach to energy externalities usually makes the LCA too uncertain to meaningfully use in decision processes (Schmidt et al., 1994). Recent product-LCA's in Denmark, looking at soft-drink bottles and cans, clearly suffer from this deficiency, making very specific assumptions of the place of production of aluminium and glass, and of the type of energy inputs to these processes. If the can manufacturer chooses to import aluminium from Tasmania or the USA instead of from Norway, the balance between the two types of packing may tip the other way (UMIP, 1996)

In practice, we shall follow the full economy approach of excluding imbedded impacts in imported goods as far as possible, but in cases where data are available only in ways that do not allow this way of splitting the impacts, we shall use our judgement to adjust the data. In cases such as the example from ExterneE mentioned above, the calculated impacts are in a developed country similar to Denmark, and we shall assume that they are similar to what they would have been if produced in Denmark. If they are not produced in Denmark but imported, we shall simply omit the impact. For countries where imports and exports are a small fraction of the GNP (e.g. USA), the problem is of much smaller proportions than for Denmark. As many previous studies attempt to include impacts from imports, we are able to compare the two approaches in Chapter 5, by estimating both impacts in Denmark including those of goods produced for export, and impacts excluding goods for export but including imbedded impacts in imports.

However, to sum up, we believe that the method in common use for product LCA, where imbedded impacts are traced through the economies of different countries, is not only very difficult to use in any practical example, but is also unsuited for the system analysis that we aim to do. In contrast, we suggest the use of a conventional economic approach, where import and export are specific features of a given economy, deliberately chosen in consideration of the assets of the country, and that LCA impacts should be calculated only for the economy in question, in order to be consistent.

The history of LCA has taken two distinct paths. One is associated with the energy LCAs, being developed from chain analysis without imbedded impacts to analysis including such impacts, both as regards environmental and social impacts. The history and state-of-the-art of energy LCA is described in Sørensen (1993 and 1996). The main ingredients of an energy LCA is listed below, at the end of this Chapter. The other path is associated with product-LCA and has been pushed by the food and chemical industries, particularly through the association SETAC (Consoli et al., 1993). SETAC tends to consider only environmental impacts, neglecting most social impacts. Both types of LCA were methodologically discussed around 1970, but only recently have they been transferred to credible calculations, because of the deficiencies in available data. Many absurd LCA conclusions have been published from the late 1960ies to the late 1980ies. The present stance is much more careful, realising that LCA is not and cannot be made a routine screening method for products or energy systems, but has to remain an attempt to furnish more information to the political decision-maker, than

has previously been available. The decision process will be of a higher quality, if these broader impacts are considered, but the technique is never going to be a computerised decision tool capable of replacing political debate before decisions are made. This is also evident from the incommensurability of different impacts, which cannot always be meaningfully brought to a common scale of units: To emphasise this view on the scope of LCA, we give a list of impacts to consider, without claiming it to be inclusive or complete:

**TABLE 1. IMPACTS TO BE CONSIDERED IN LIFE-CYCLE ANALYSIS OF ENERGY SYSTEMS**

- a. Economic impacts such as impacts on owners economy and on national economy, including questions of foreign payments balance and employment.
- b. Environmental impacts, e.g. land use, noise, visual impact, local, regional and global pollution of soil, water, air and biota, impacts on climate.
- c. Social impacts, related to satisfaction of needs, impacts on health and work environment, risk, impact of large accidents.
- d. Security and resilience, including supply security, safety against misuse, terror actions as well as sensitivity to system failures, planning uncertainties and changes in future criteria for impact assessment.
- e. Development and political impacts, such as degree of consistency with goals of a given society, impacts of control requirements and institutions, openness to decentralization and democratic participation.

The types of impacts that may be contemplated for assessment reflect to some extent the issues that at a given moment in time have been identified as important in a given society. It is therefore possible, that the list will be modified with time, and that some societies will add new concerns to the list. However, the following groups of impacts, a summary of which are listed in Table 1, constitute a fairly comprehensive list of impacts considered in most studies made to date (Sørensen, 1993):

**\* Economic impacts such as impacts on owners economy and on national economy, including questions of foreign payments balance and employment.**

This group of impacts aim at the direct economy reflected in market prices and costs. All other impacts can be said to constitute indirect costs or externalities, the latter if they are not included in prices through e.g. environmental taxes. Economy is basically a way of allocating scarce resources. Applying economic assessment to an energy system, the different payment times of different expenses have to be taken into account, e.g. by discounting individual costs to present values. This again gives rise to different economic evaluations for an individual, an enterprise, a nation, and some imaginary global stake holder. One possible way of dealing with these issues is to apply different sets of interest rates for the above types of actors, and in

some cases even a different interest rate for short-term costs and for long-term, inter-generational costs, for the same actor. Ingredients in these kinds of economic evaluation are the separate private economy and national economy accounts often made in the past. The national economy evaluation includes such factors as import fraction (balance of foreign payments), employment impact (i.e. distribution between labour and non-labour costs), and more subtle components such as regional economic impacts. Impact evaluations must pay particular attention to imports and exports, as many of the indirect impacts will often not be included in trade prices, or their presence or absence will be unknown.

**\* Environmental impacts, e.g. land use, noise, visual impact, local pollution of soil, water, air and biota, regional and global pollution and other impacts on the Earth-atmosphere system, such as climatic change.**

Environmental impacts include a very wide range of impacts on the natural environment, including both atmosphere, hydrosphere, lithosphere and biosphere, but usually with the human society left out (but to be included under the heading social impacts below). Impacts may be classified as local, regional and global. At the resource extraction stage, in addition to the impacts associated with extraction, there is the impact of resource depletion. In many evaluations, the resource efficiency issue of energy use in resource extraction is treated in conjunction with energy use further along the energy conversion chain, including energy used to manufacture and operate production equipment. The resulting figure is often expressed as an energy pay-back time, which is reasonable because the sole purpose of the system is to produce energy, and thus it would be unacceptable if energy inputs exceeded outputs. In practise, the level of energy input over output that is acceptable depends on the overall cost, and should be adequately represented by the other impacts, which presumably would become large compared with the benefits, if energy inputs approached outputs. In other words, energy pay-back time is a secondary indicator, which should not itself be included in the assessment, when the primary indicators of positive and negative impacts are sufficiently well estimated. Also issues of the quality of the environment, as seen from an anthropogenic point of view, should be included here. They include noise, smell and visual impacts associated with the cycles in the energy activity. Other concerns could be the preservation of natural flora and fauna. It is normally necessary to distinguish between impacts on the natural ecosystems and those affecting human well-being or health. Although human societies are of course part of the natural ecosystem, it is convenient and often necessary to treat some impacts on human societies separately, which will be done in the following group. However, the situation is often, that a pollutant is first injected into the natural environment, and later finds its way to humans, e.g. by inhalation or through food and water. In such cases the evaluation of health impacts involves a number of calculation steps (dispersal, dose-response relation) that naturally have to be carried out in order.

**\* Social impacts, related to satisfaction of needs, impacts on health and work environment, risks, impact of large accidents.**

Social impacts include the impacts from using the energy provided, which means the positive

impacts derived from services and products arising from the energy use (usually with other inputs as well), and the negative impacts associated with the energy end-use conversion. Furthermore, social impacts derive from each step in the energy production, conversion and transmission chain. Examples are health impacts, work environment, job satisfaction, and risk, including the risk of large accidents. It is often useful to distinguish between occupational impacts and impacts to the general public. Many of these impacts involve transfer of pollutants first to the general environment and then to human society, where each transfer requires separate investigation as stated above. This is true both for releases during normal operation of the facilities in question, and for accidents. Clearly, the accident part is a basic risk problem that involves estimating probabilities of accidental events of increasing magnitude.

**\* Security impacts, including both supply security and also safety against misuse, terror actions, etc.**

Security can be understood in different ways. One is supply security, and another the security of energy installations and materials, against theft, sabotage and hostage situations. Both are relevant in a life-cycle analysis of an energy system. Supply security is a very important issue, e.g. for energy systems depending on fuels unevenly spread over the planet. Indeed, some of the most threatening crises in energy supply have been related to supply security (1973/74 oil supply withdrawal, 1991 Gulf War).

**\* Resilience, i.e. sensitivity to system failures, planning uncertainties and future changes in criteria for impact assessment.**

Resilience is also a concept with two interpretations: One is the technical resilience, including fault resistance and parallelism, e.g. in providing more than one transmission route between important energy supply and use locations. Another is a more broadly defined resilience against planning errors (e.g. resulting from a misjudgement of resources, fuel price developments, or future demand development). A more tricky, self-referencing issue is resilience against errors in impact assessment, assuming that the impact assessment is used to make energy policy choices. All the resilience issues are connected to certain features of the system choice and layout, including modularity, unit size, and transmission strategy. The resilience questions may well be formulated in terms of risk.

**\* Development impacts (e.g. consistency of a product or a technology with the goals of a given society).**

Energy systems may exert an influence on the direction of development, a society will take, or rather may be compatible with one development goal and not with another goal. These could be goals of decentralisation, goals of concentration on knowledge business rather than heavy industry, etc. For so-called developing countries, clear goals usually include satisfying basic needs, furthering education, and raising standards. Goals of industrialised nations are often more difficult to identify.

**\* Political impacts include e.g. impacts of control requirements, and on openness to decentralisation in both physical and decision-making terms.**

There is a geopolitical dimension to the above issues: Development or political goals calling for import of fuels for energy may imply increased competition for scarce resources, an impact which may be evaluated in terms of increasing cost expectations, or in terms of increasing political unrest (more "energy wars"). The political issue also has a local component, pertaining to the freedom or lack of freedom of local societies to choose their own solutions, possibly different from the one selected by the neighbouring local areas.

### 3. SCENARIO CHOICES

The LCA methodology will be applied to three energy systems, of which one represents the present system (using 1992-1995 data) and the two other ones are future scenarios for the middle of the 21st century, both with strong penetration of renewable energy sources and the assumption of no come-back for nuclear power. Otherwise the scenarios are very different, as they represent two extreme views of social development, which are penetrating current political debates and represent value systems held by large groups in society:

One is an ecologically driven scenario, assuming a majority of the Danish population to prefer a strict environmental policy, where decision involving potentially large but uncertain dangers to the environment are not taken, even if they appear economically attractive. The other scenario is market driven, but assumes externalities to be considered explicitly, either by including their monetised value in costs, or by implementing taxes and regulations that will limit the use of the undesirable products or practices. This scenario is called a "fair market scenario", as it tries to correct the omission of environmental and social costs from free market economies, by some average or agreed value of the known impacts. This is in opposition to the "precautionary principle" built into the ecologically driven scenario, which may turn out to overestimate externalities, by effectively excluding options that are too uncertain. The fair market proponents would argue, that it is worth taking the chance, as the uncertain impacts in the future may turn out to be overestimated, or even if they are not, a future society with a higher technological level may better be able to repair any damage incurred, and at a lower cost than we would think today.

From a methodological point of view, the ecological scenario is the simplest, as one just has to calculate the LCA impacts of a prescribed system. For the fair market scenario, there is a coupling from the scenario choices back to the LCA calculation, which in principle has to be made first, in order to select the precise scenario assumptions regarding the use of different technologies. This could invite an iterative optimisation procedure, but we shall just make one pass through the system, as our point of view is that we select scenarios used elsewhere chosen because they represent interesting futures, and then calculate the LCA impacts of these without altering the scenarios. The sections below give a more detailed description of the data assumptions of the three systems analysed.

#### 3.1 Present energy system

The current demand is shown in Table 2 and the energy system in Figures 2 and 3. These are based on 1992 data, because these were used as starting point in the ecologically sustainable scenario, including the attempt to distribute the end-uses on categories of energy quality. From 1992 to 1996, the Danish oil and gas production in the North Sea increased although this is not expected to continue to 2030, because of the limited resources expected in the North Sea. Coal



is still the major source of electric power production, and renewable energy use is increasing although still modest.

**Table 2. Danish energy demand 1992 in PJ (Sørensen et al., 1994)**

Sector	Delivered energy	Net energy	End-use energy	Energy quality
Electric heating	9	9	70	Space heating
Fuels for heating	190	153	25	Stationary mechanical energy
Electrical appliances	44	44	10	Electrical appliances
Cooling and refrigeration	15	15	5	Cooling and refrigeration
Electricity for process heat	41	41	18	Process heat under 100°C
Fuels for process heat	111	91	4	Process heat 100-500°C
Electricity for transportation	1	1	3	Process heat over 500°C
Fuels for transportation	173	173	26	Transport work
			20	Energy in food
<b>Total</b>	<b>584</b>	<b>527</b>	<b>181</b>	<b>Total</b>

The delivered energy in Table 2 is the energy delivered to the end users. The net energy subtracts conversion losses in local boilers and furnaces, but does not correct for conversion losses in the transport sector. The estimated end-use energy is the true net energy needed to deliver the services of the actual system, had all been delivered by the most efficient devices available today. The net energy for heating includes hot water used in the domestic and service sectors, whereas this has been listed as low-temperature process heat in the end-use column. The net energy for electrical appliances includes heating of water and low-temperature cooking, which in the end-use column is included under process heat under 100°C, and some stationary mechanical energy used in the service industry. The net process energy includes not only true process heat used in agriculture and industry, but also space heating, hot water, stationary mechanical energy and energy for electric appliances used in these sectors. In the end-use columns, an attempt has been made to categorise these correctly, and again to adjust to the efficiency of the best conversion equipment. For the transportation sector, the end-use energy is obtained by applying an average conversion efficiency of current vehicles.

Figures 2 and 3 gives a picture of the 1992 conversions between the primary and end-use energy in the Danish system, starting in Figure 2 with a picture of the agricultural sector in

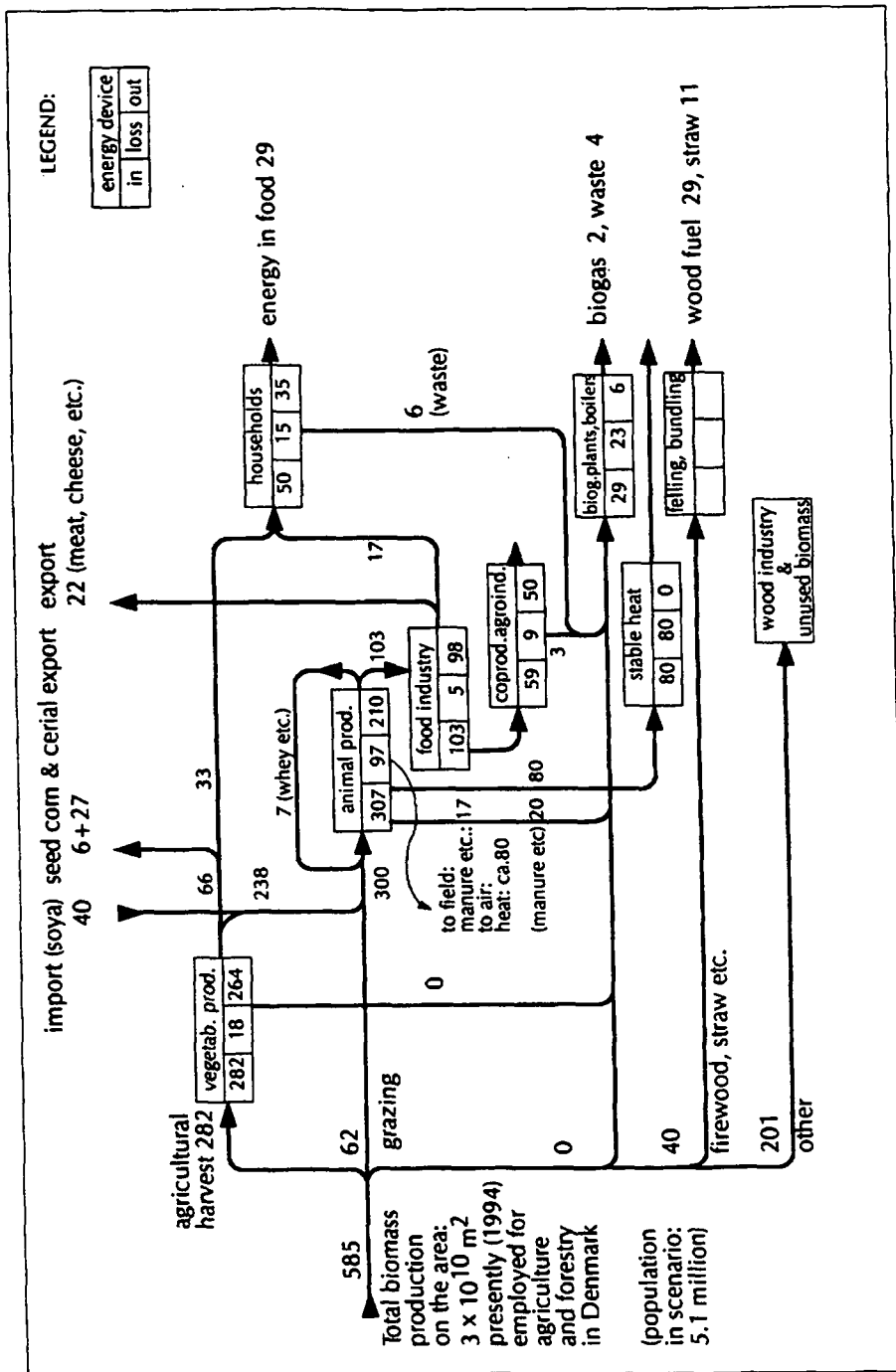

Figure 2. Danish 1992 biomass sector (excluding indirect energy inputs for fertilisers, machinery etc. Units: PJ/y (Sørensen et al., 1994).

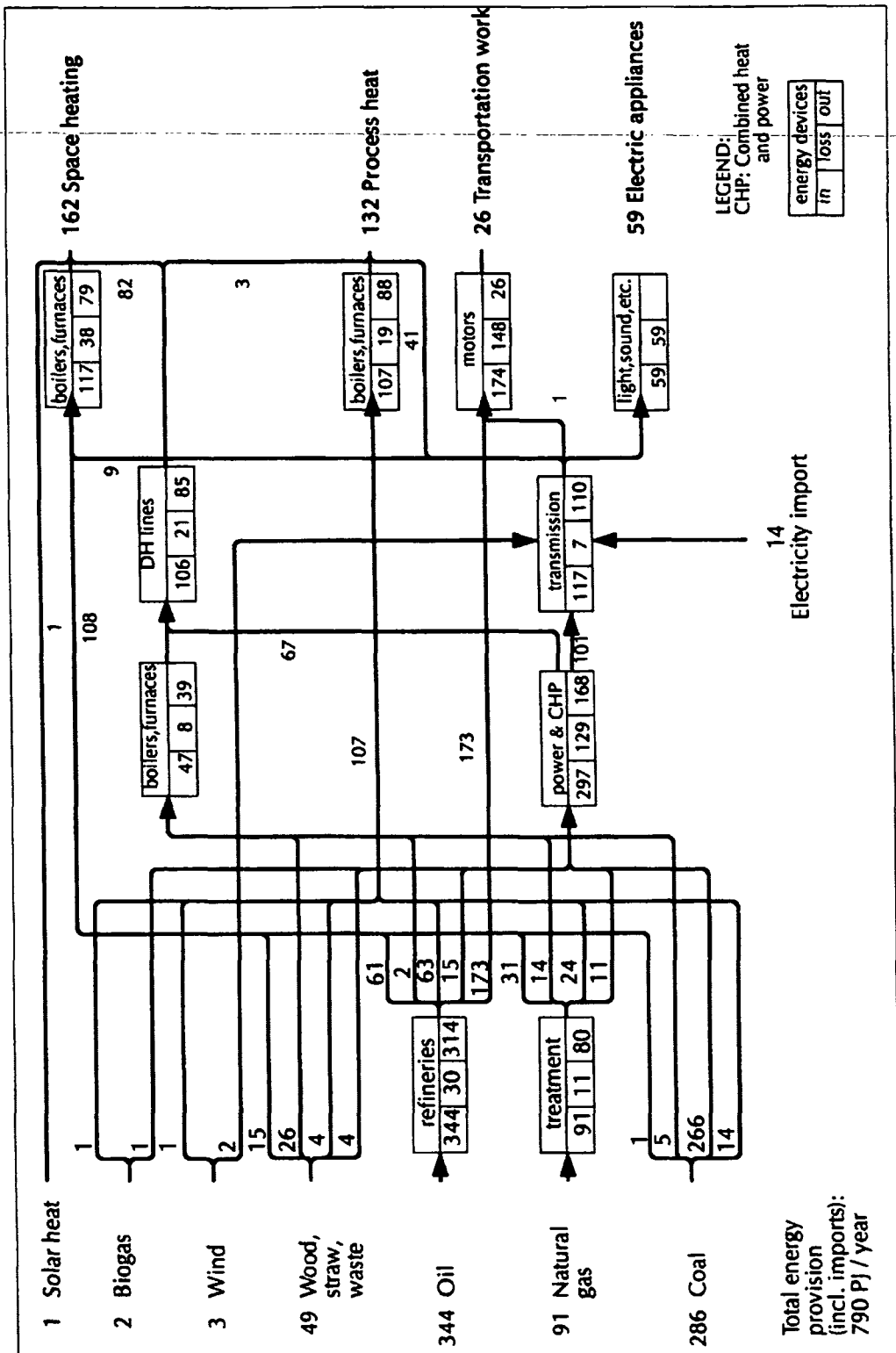

Figure 3. Danish energy system 1992. Units: PJ/y. (Sørensen et al., 1994).

energy units. This illustrates the large magnitude of agricultural energy manipulations and the small fraction of these presently contributing to energy supply. The energy conversions illustrated in Figure 3 indicates a fairly efficient range of intermediate conversions, followed - however - by a relatively inefficient range of end-use conversions, particularly as regards the combustion motors used in the transportation sector. Efficiencies of electrical appliances have not been estimated here, but may be found together with efficiency analyses of other conversion equipment in Sørensen (1991), and in a condensed form in Sørensen (1992).

### 3.2 The ecologically sustainable scenario

The ecologically driven scenario was constructed in 1994 by a working group of the Danish Technology Council (Sørensen et al., 1994), as one of two scenarios considered for the year 2030. It is a normative scenario, assuming broad concern in the Danish population over issues such as greenhouse warming. The preamble to the scenario describes the sudden onset of grave consequences of the greenhouse warming, such as failure of harvests in the US and European cereal belts and flooding of lowlands in Bangladesh and elsewhere. These events, occurring shortly before the year 2010, convince a majority of the Danish population that a concerted effort must be made to change the energy system away from reliance on fossil fuels. The study first defines the energy demand at the end user, by analysing all activities of society, starting from coverage of basic needs for food, shelter and human relations, and continuing into a range of secondary needs, that are left open ended in realisation of the futility of trying to guess what possibilities will be explored 35 years from now. However, they are broadly characterised by energy requirements based on the trend of increased introduction of devices using electric energy, as well as increased efficiency of any energy form used. The assumed energy demand is shown in Table 3, distributed on energy qualities.

In order to satisfy this energy need, the energy system layout shown in Figure 5 was constructed, with an agricultural sector providing biomass energy as shown in Figure 4. The primary side of the Danish energy scenario has a large proportion of electric power, primarily due to abundant wind resources, and therefore electricity is supplied to uses of other energy qualities, such as high-temperature process heat as well as low temperature heat, but in that case using heat pumps to ensure efficient use of the electricity. The cold reservoirs of the heat pumps may under Danish conditions be the ground or aquifers storing absorbed solar heat. The intermittent supply of wind power and solar heat and power is dealt with in the following ways: For electricity, the use of reversible fuel cells (centrally or dispersed into buildings) allows surplus electricity to be converted into gas, that is stored (Denmark has identified a number of underground caverns and aquifers suitable for this purpose), and later reused for generating electricity and associated heat (distributed through already existing district heating lines). In the case of solar heat, the strong seasonality is dealt with by intelligent use of heat storage and the existing district heating lines: These lines, distributing low-temperature heat, will accept solar heat collected during the sunny months of March to October, but will make use of co-produced heat from fuel cells and combined heat and power plants during winter

	1. Cooling & refrigeration	2. Space heating	3. Process heat under 100°C	4. Process heat 100-500°C	5. Process heat over 500°C	6. Stationary mechanical energy	7. Electric appliances	8. Transportation work	9. Food energy	TOTAL
A. Biologically acceptable surroundings	0	258	0	0	0	0	0	0	0	258
B. Food and water	18	0	3	6	0	0	0	0	120	147
C. Security	0	1	0	0	0	0	0	1	0	2
D. Health	0	0	129	0	0	0	0	0	0	129
E. Relations, leisure	0	0	0	0	0	0	48	36	0	84
F. Activities:	0	0	0	0	0	60	0	9	0	69
Construction	12	120	12	0	0	6	24	27	0	201
Trade, service and distribution	0	0	12	0	0	6	0	3	0	21
Agriculture	9	102	12	12	6	60	24	9	0	234
Manufacturing industry	0	0	12	12	12	30	12	9	0	87
Raw Materials and energy industry	0	24	0	0	0	0	2	0	0	26
Education	0	0	0	0	0	0	0	9	0	9
Commuting	0	0	0	0	0	0	0	0	0	0
TOTAL	39	505	180	30	18	162	110	103	120	1267

Table 3. The energy demand of the ecologically sustainable scenario for Denmark in year 2030, assuming high efficiency and environmental concern to be driving the demand. Units: W per capita, 1267 W/cap. equals 211 PJ/y. (Sørensen et al., 1994).

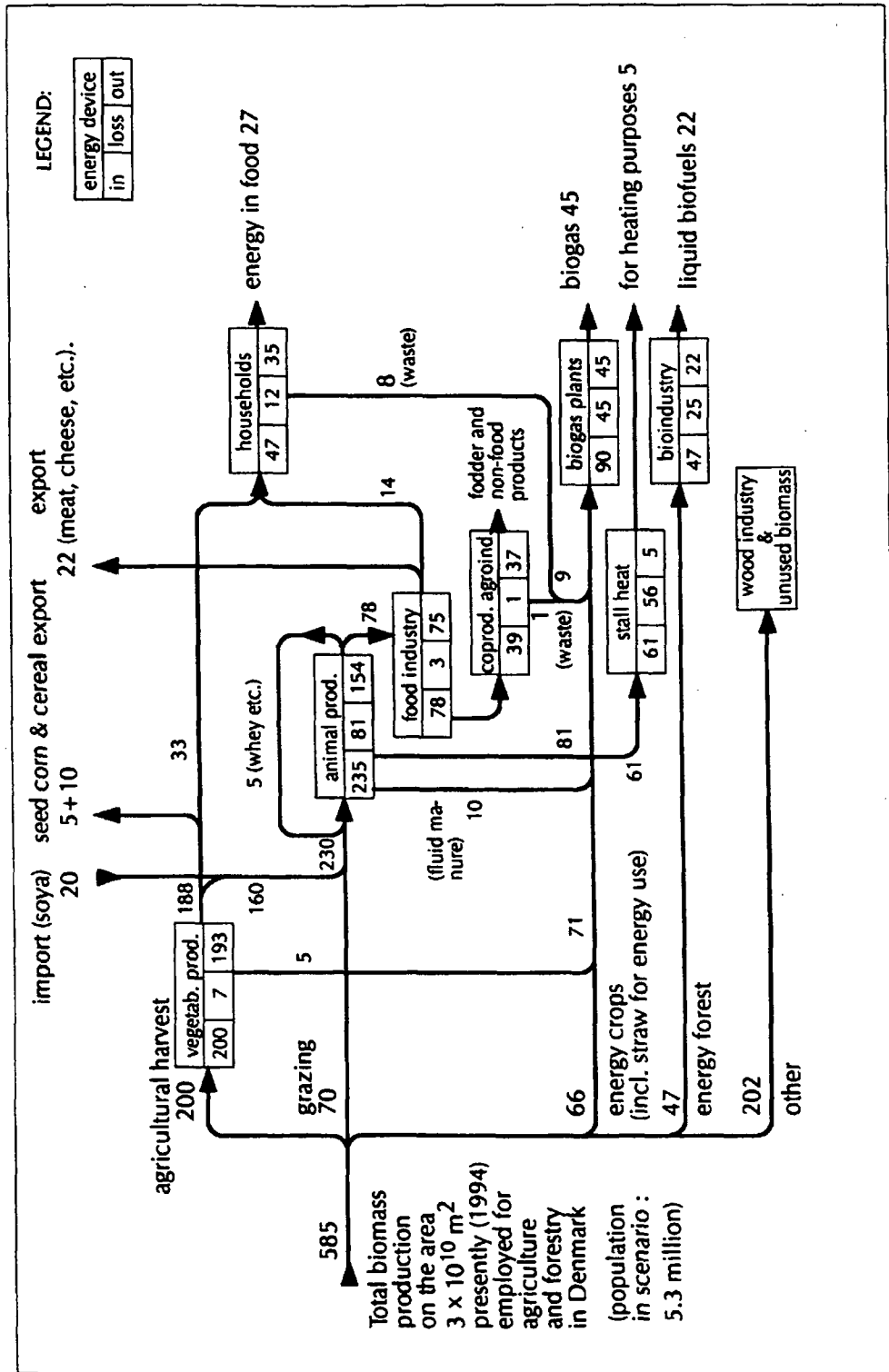

Figure 4. Ecologically sustainable scenario for the Danish agricultural sector in 2030. Units: PJ/y. (Sørensen et al., 1994).

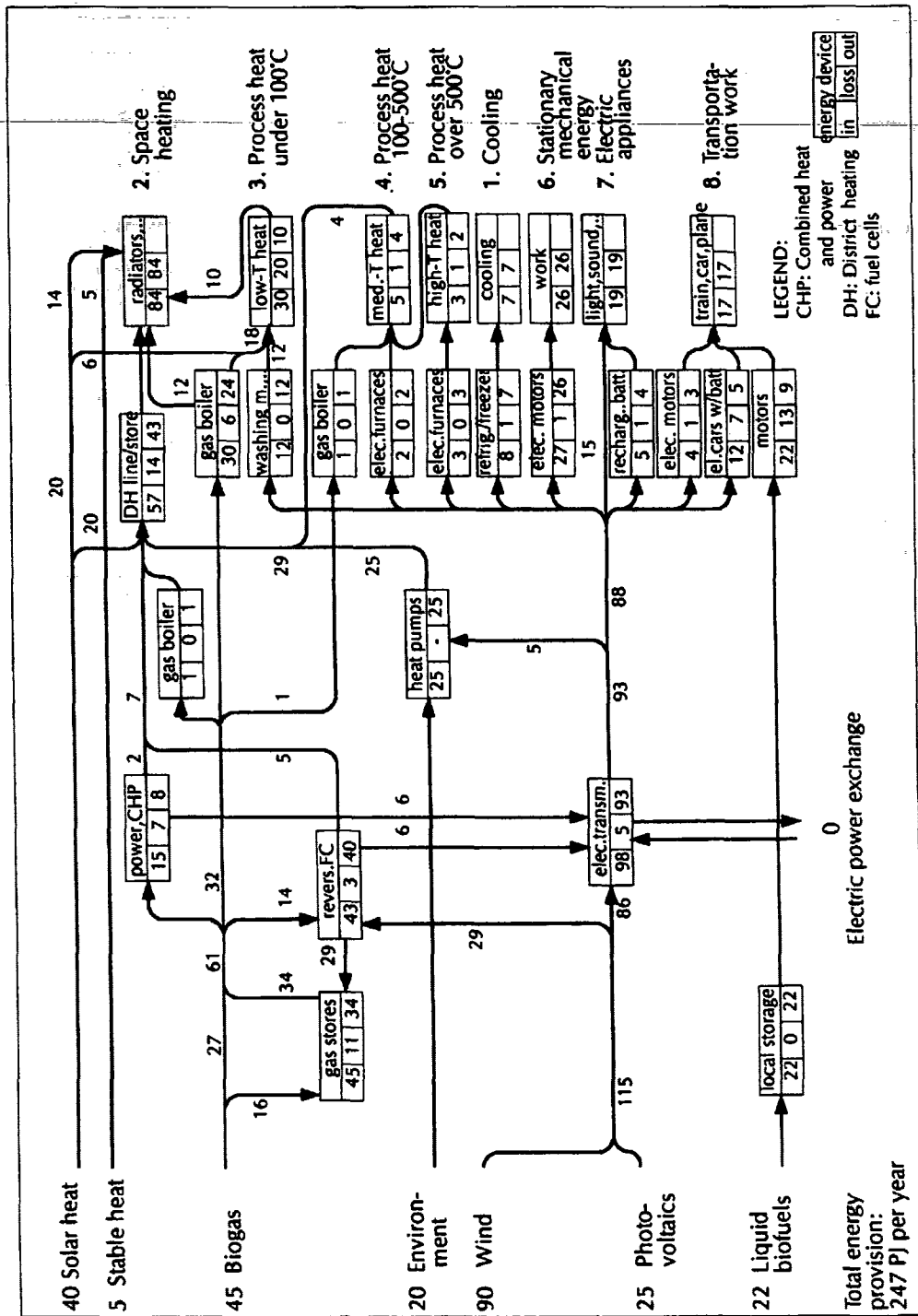

Figure 5. Ecologically sustainable scenario for the Danish energy system in 2030. Units: PJ/y (Sørensen et al., 1994).

and in case of insufficient solar heat supply. The source of the alternative heat (except from the surplus power mentioned above) is biogas, which again can be stored. Large biogas plants are already operating in Denmark.

Figures 6 and 7 show the overall change in Danish energy demand and supply between 1992 and 2030, for the environmentally sustainable scenario. The 2030 end-use demand has in Figure 6 been divided according to the same sectors as used in 1992 official statistics (Danish Energy Agency, 1995).

The scenario construction for the Technology Council was based on average supplies and no detailed investigation of energy storage requirements were made. It was assumed that for electricity, the international grid connections would take care of any mismatch, which is supported by the existence of large quantities of reservoir-based hydro power in the region (an investigation by Meibom et al. (1997) of these matters by hourly simulation is underway).

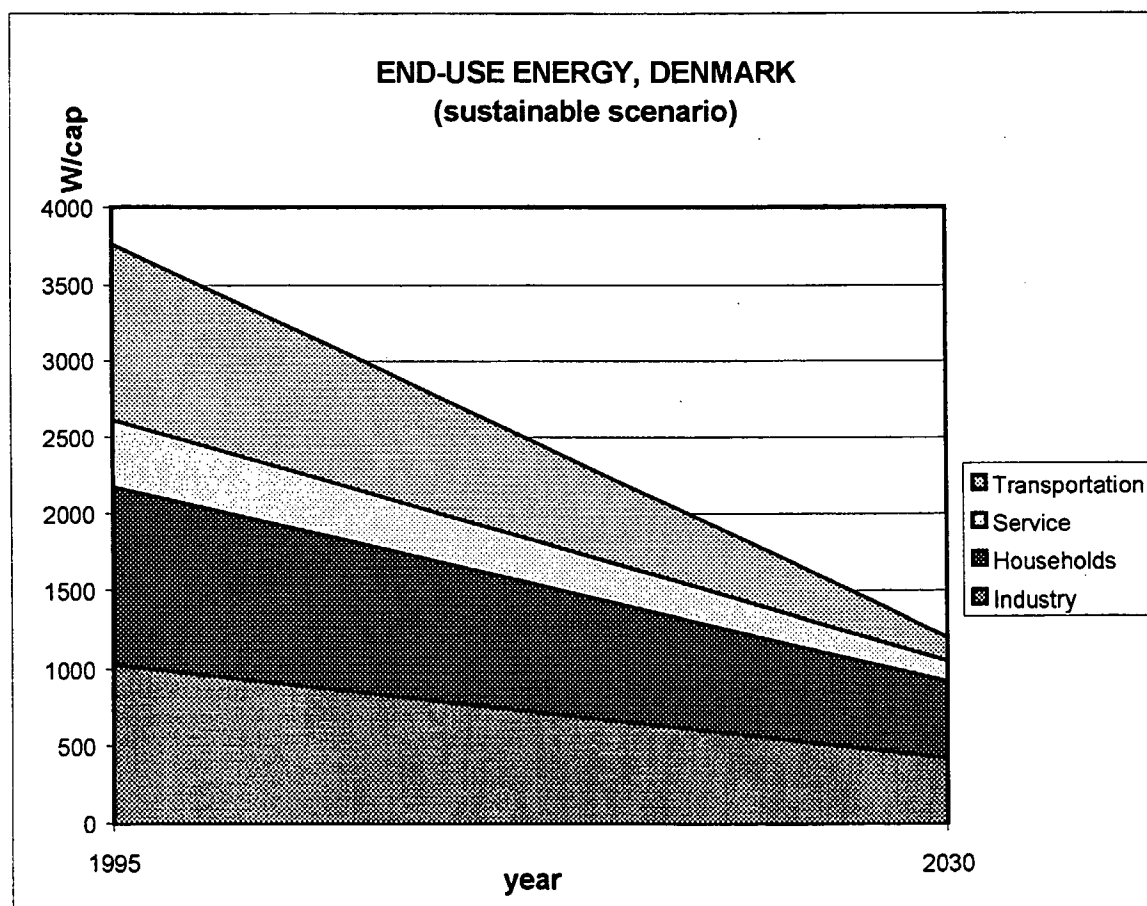

Figure 6. Development in end-use energy demand in the ecologically sustainable scenario.



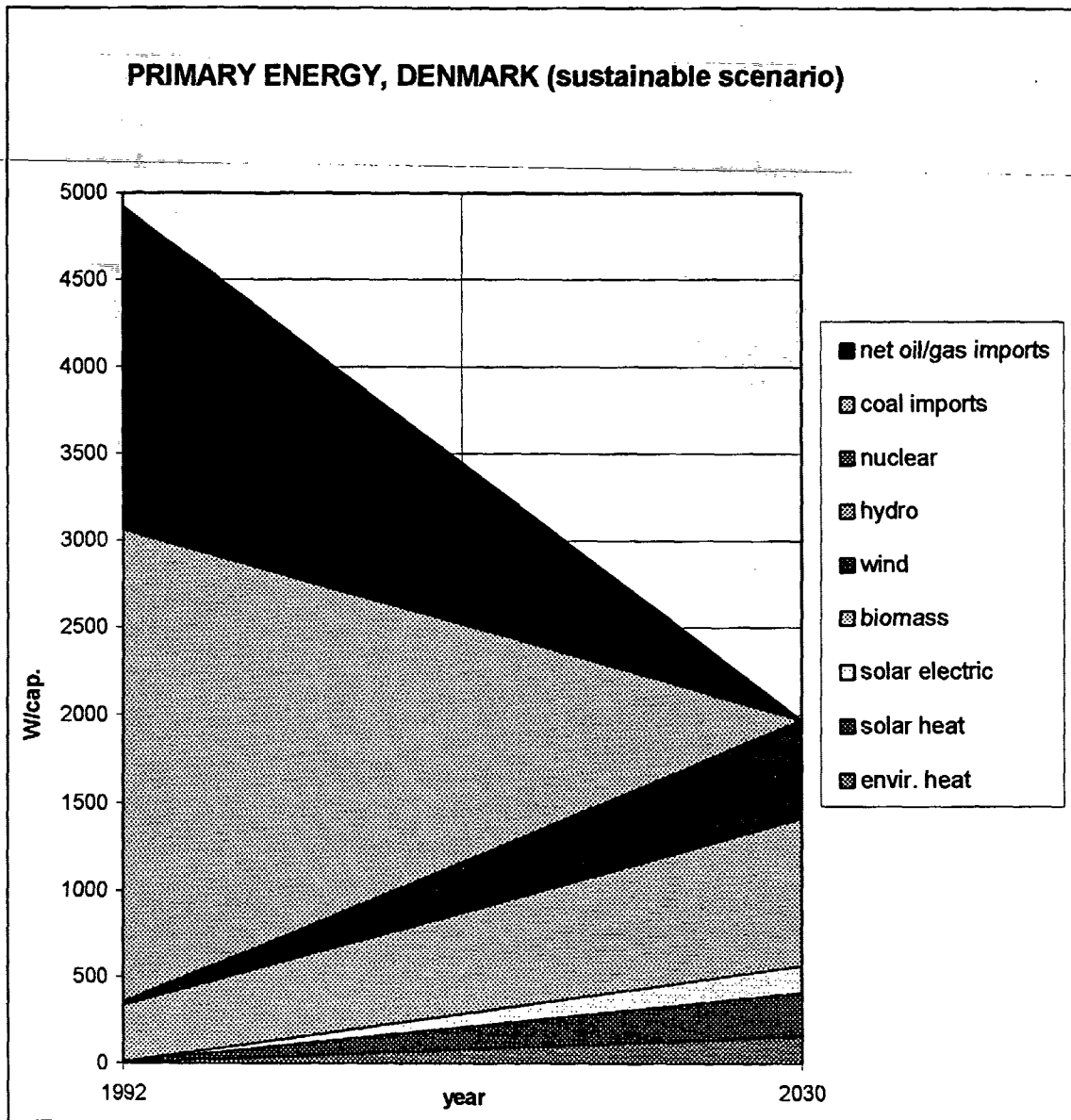

Figure 7. Primary energy supply development in the ecologically sustainable scenario.

### 3.3 The fair market scenario

The idea behind the fair market scenario is not to assume any abrupt change in values and preferences of the population, but to assume the current trends of a higher consideration for the environment to continue and lead to acceptance of the inclusion of environmental externalities into the prices of energy goods and services. This is what makes the market "fair". As in one interpretation of the current situation, the market is allowed to operate freely as long as this does not lead to severe distortions of that same market (e.g. by formation of monopolies), but with a number of rules defined by society. These rules may be building codes that prevent the market operators from building houses below a certain standard, as regards safety and recently also energy use. It is only a small step from building codes to considering e.g. the cost of polluting emissions from burning fossil fuels. However, there are two ways of dealing with such issues in a market economy. One is by legislation and regulation, the other by incorporating externalities into the prices, which typically implies adding an environmental tax. The legislative way is certain to work, and it leaves a market free to compete under the given constraints, but may in some cases be seen as interfering too strongly with the freedom of choice. On the other hand, the taxation method makes it possible for people that are willing to pay the price to continue "bad" habits, and it generally involves the subtle question of the size of price signals needed to alter behaviour. It also assumes that the market will develop alternatives, as otherwise there would be no choice but to accept the higher prices. Finally, the tax method does in contrast to the regulative method lead to accumulation of funds by the state, which in our mixed economy may be seen as a good thing, whereas in straight market systems with no social security arrangements there is no point in collecting money at the state level. In the mixed economies, the notion of environmental taxation is even seen as positive as compared with indiscriminate taxation, because citizens may easier understand a tax that is serving a definite environmental purpose. Still, also the need for social security should be well understood by members of a country having a mixed economy, and the question arises, if the revenues from an environmental tax should be used freely for any purpose, or should rather be ear-marked for use in speeding up the transition to a less polluting energy system (in our case). In the latter case, the level of taxation may be lower, as it would count twice, first by influencing people's choices of energy purchase, and secondly by contributing to the development of better and cheaper low-polluting energy technology. All these issues depend rather sensitively on the actual size of the fair environmental taxes, i.e. on the difficult evaluation of environmental impacts in monetary terms.

Central in the fair market scenario is thus the choice of environmental "adders" (a common word for either taxes or fictive cost supplements used only in decision-making), i.e. the size of externalities that the model will assume to be internalised in the future. The original fair market scenario was constructed for the 15 members of the European Union (Nielsen and Sørensen, 1996) and based on externality estimates derived from the Second IPCC Assessment Report (IPCC II, 1996). A key parameter, the monetary loss to society of an extra death occurring in the society, was taken as 2.6 million ECU as estimated in a recent EC project (European Commission, 1995a-g). Figures 8-11 gives the development during the scenario period 1990-2050 in the cost of energy from different sources, with the externalities assumed to drive the fair market scenario. In chapter 4 we shall look further into the derivation of life-cycle costs for the technologies entering in the scenario. The fair market scenario requires a self-consistency between its input assumptions and the social costs that are calculated from the scenario.

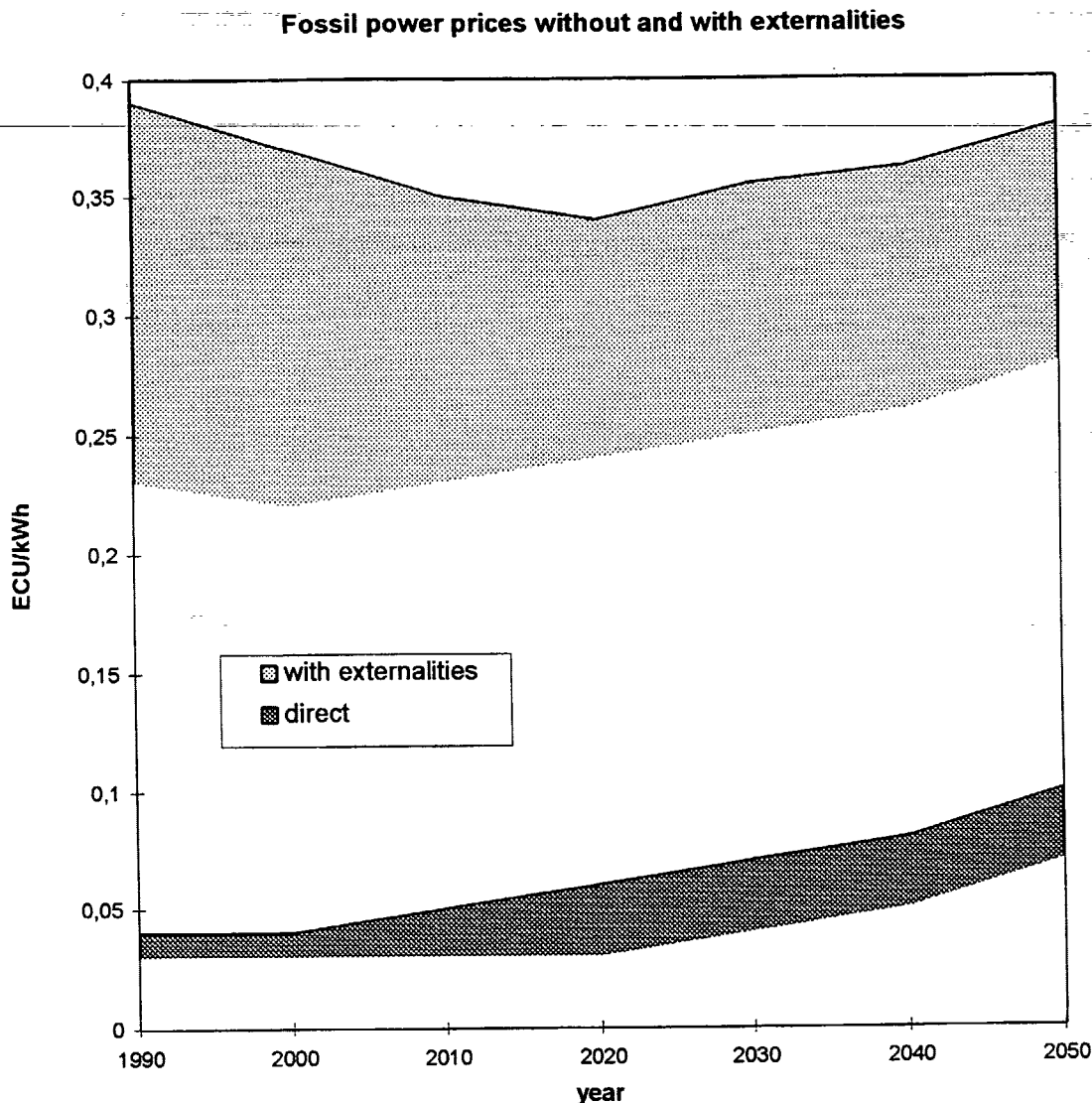

Figure 8. Prices of fossil power assumed in the fair market scenario, with and without externalities. The higher values are for coal fired power stations, the lower ones for natural gas fired stations. The most significant contribution to the externality cost is the greenhouse warming impacts, but in the early period there is a contribution from SO<sub>2</sub> and NO<sub>x</sub> emissions, particularly from older, existing power plants (Nielsen and Sørensen, 1996).

Cost of wind power (externalities within uncertainty)

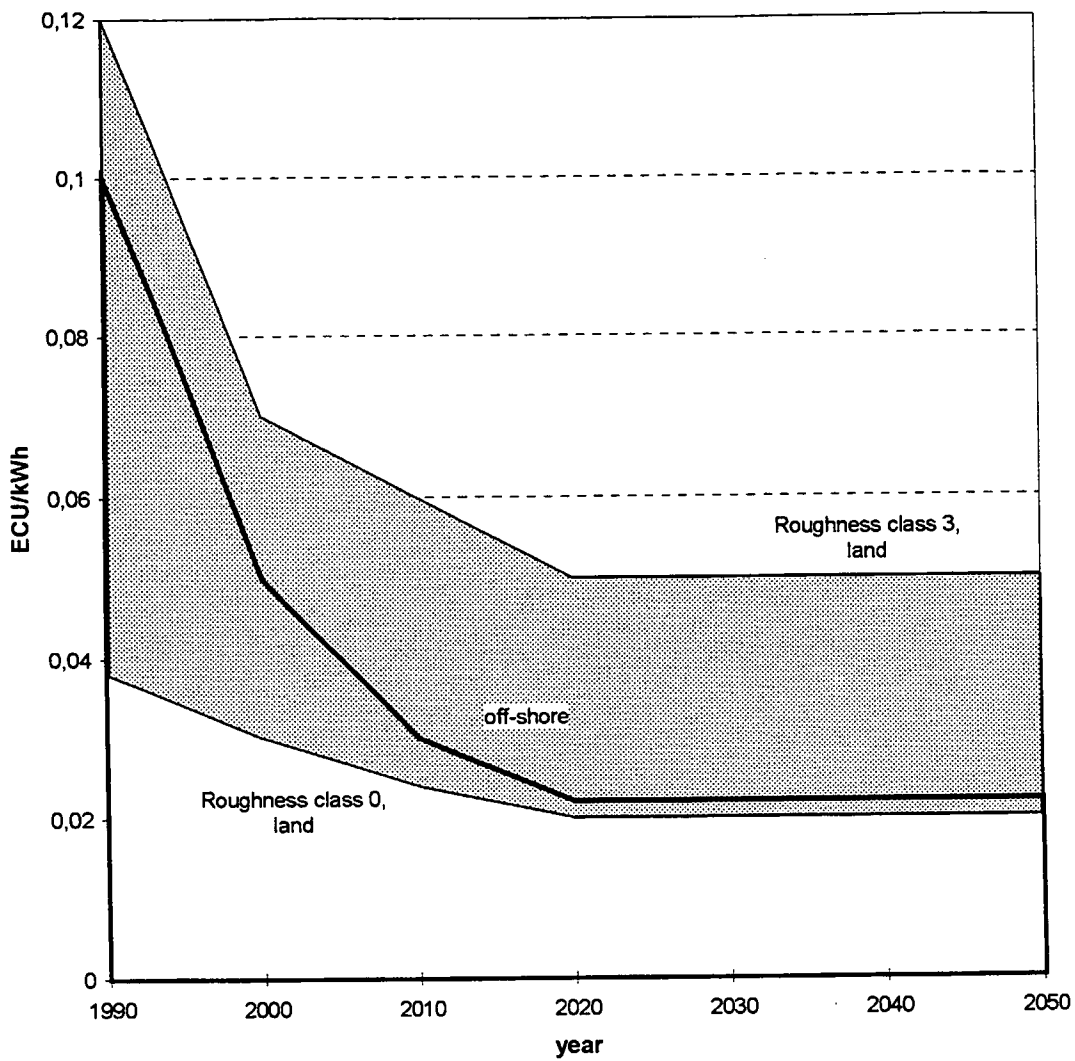

Figure 9. Cost of wind power (including externalities calculated to be only about 10% of the total cost), assumed in the fair market scenario (Nielsen and Sørensen, 1996).

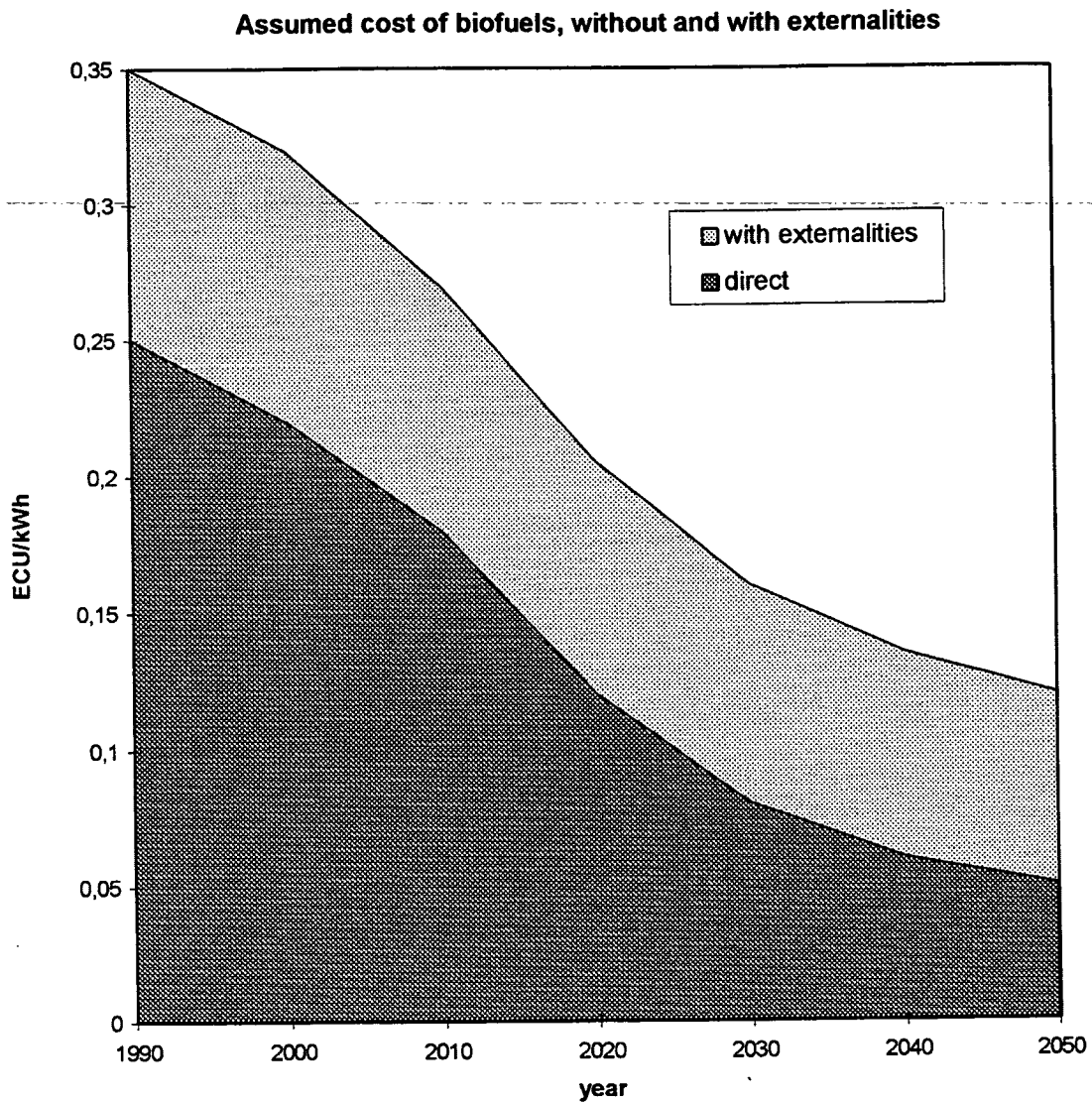

Figure 10. Costs assumed in the fair market scenario, for biofuels such as methanol for the transportation sector. The costs are gross estimates based upon qualitative externality estimations and very rough monetising efforts (Nielsen and Sørensen, 1996).

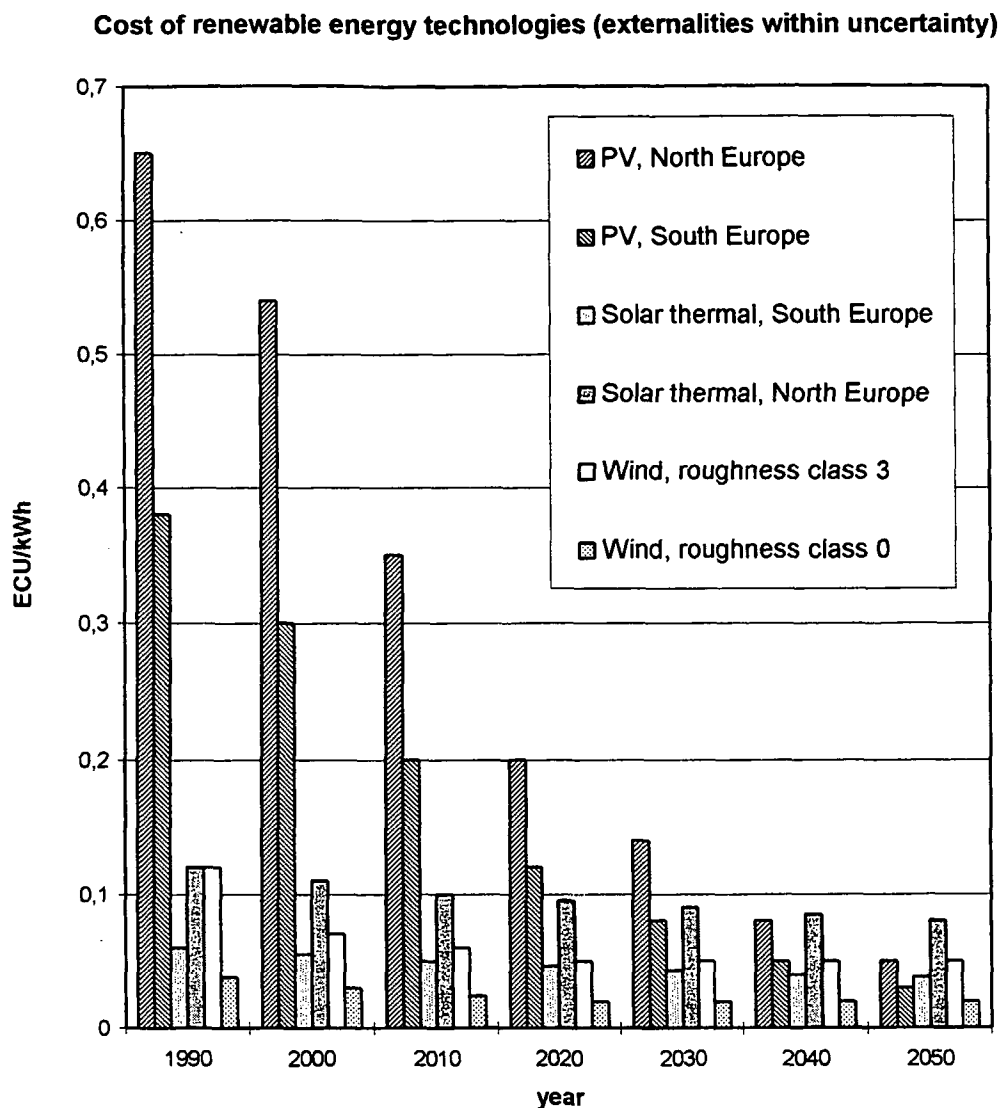

Figure 11. Summary of some renewable energy costs including externalities from life-cycle assessment, that have been used in the fair market scenario. As the externalities are modest, the trend is mostly indicating an expected cost reduction due to technology progress and mass production, that has been identified in the technology analysis of the European project (LTI Project Group, 1996; Nielsen and Sørensen, 1996).

In Tables 4, 5 and Figure 12, the Danish energy demand assumed to emerge from the assumptions made above in a market driven development, is shown. It is seen, that it is assumed that new, untraditional industry types will dominate by the mid-21<sup>st</sup> century. They are in the fair market scenario assumed to be information-based technologies, with less energy demand than heavy industry. The decrease in energy for space heating in buildings experienced over the last decades is assumed to continue and accelerate, due to inclusion of externalities in the cost of fossil fuels, which is the driving force in the fair market scenario. The heated area per person is assumed to increase, and the energy use for heating is stabilising in the early 21<sup>st</sup> century. For the transportation energy use, it is assumed that person-kilometres travelled will continue to increase, particularly for air travel. This is in strong contrast to the ecologically

sustainable scenario, where actual travel is assumed to decrease with time, due to the replacement by advanced telecommunication options available in the information society, reserving physical travel to personal contacts, particularly between friends and relatives.

**Table 4. Danish energy demand development in fair market scenario (Nielsen and Sørensen, 1994).**

Fair market scenario	unit: PJ/y				
Denmark	1990	2000	2010	2030	2050
<b>all sectors</b>	<b>514</b>	<b>522</b>	<b>426</b>	<b>348</b>	<b>252</b>
<b>households</b>	<b>171</b>	<b>153</b>	<b>127</b>	<b>97</b>	<b>61</b>
electricity	33	19	13	16	18
space heat	113	109	95	69	36
hot water	25	26	19	13	6
fuel for cooking	0	0	0	0	0
<b>service</b>	<b>40</b>	<b>30</b>	<b>22</b>	<b>24</b>	<b>25</b>
electricity	28	19	12	17	21
fuels	11	11	10	7	4
<b>industry</b>	<b>116</b>	<b>107</b>	<b>98</b>	<b>76</b>	<b>48</b>
electricity	31	30	28	28	30
fuels	84	77	70	58	48
<b>transport</b>	<b>188</b>	<b>231</b>	<b>178</b>	<b>150</b>	<b>119</b>
road	134	164	98	72	49
rail	5	5	5	5	4
air	29	40	50	52	43
waterway	20	23	25	21	22

**Table 5. Fair market scenario. Details of industry energy demand**

Sectorial distribution of total Danish industry energy use:			
percentage	1990	2020	2050
iron & steel	6	5	3
chemical, petrochem.	14	12	7
non-ferrous metals	0	0	0
non-metallic minerals	19	16	9
food & tobacco	26	21	12
paper, pulp & printing	5	5	3
textiles & leather	3	2	1
other	27	39	65

### DANISH END-USE ENERGY IN FAIR MARKET SCENARIO

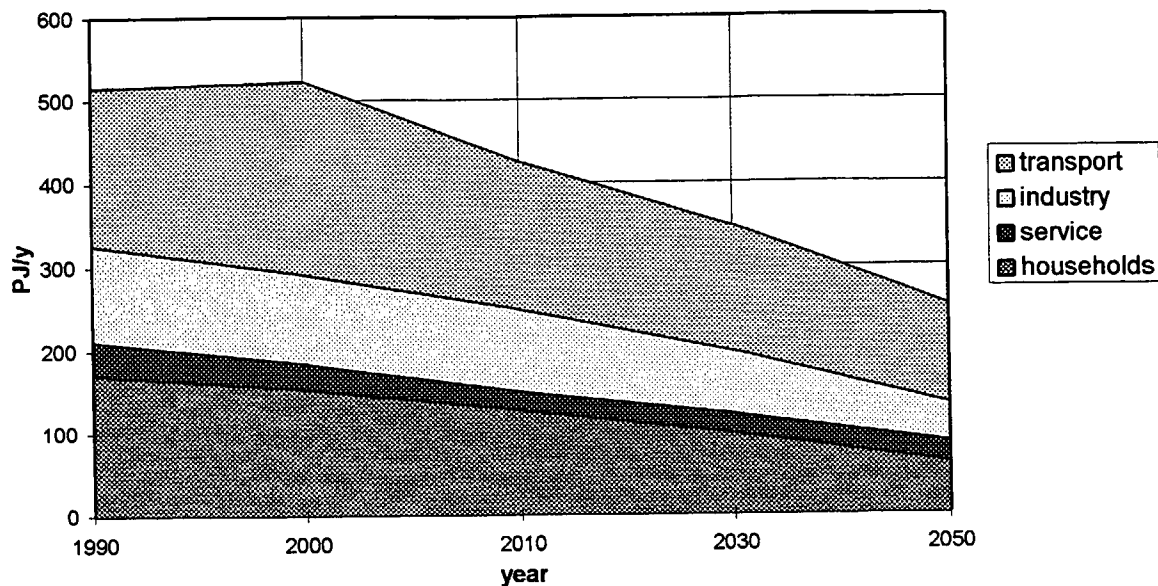

Figure 12. Development in Danish end-use in the fair market scenario.

The primary energy input for the Danish part of the fair market scenario is shown in Figure 13 (without giving the structure of intermediate years, because it is not evaluated for each country in the project), and the total primary energy development for the 15 EU countries is shown in Figure 14. Nuclear energy is phased out (one of the conditions of the LTI project (1996) that the fair market scenario is part of), and the fossil energy use is reduced so that an 80% reduction in greenhouse gas emissions is met. In the fair market scenario, this goal is more than reached as a consequence of including the greenhouse externalities in the fair process. As expected, wind reaches a higher proportion in Denmark than in the Southern European countries, end solar energy (heat or electricity) a lower proportion.

Figure 15 gives the a more detailed picture of the key features of the fair market scenario for Denmark in the year 2050, while Figure 16 gives the overall European picture. A simplified version of the European 1990 and 2050 energy systems is shown on a per capita basis in Figure 17. Imports and exports are outlined in Figure 18, indicating considerable trade among the countries, as well as with countries outside the EU, notable Norway, the Middle East and North Africa. The option of a substantial trade in energy among the European countries has had a profound influence on the set-up of renewable energy systems in the different countries. Countries with good solar conditions (Portugal, Spain, Italy, Southern France and Greece) produce more photovoltaic power than they can use internally, and countries located in good wind conditions (Denmark, UK etc.) similarly enhance their production of wind power in the interest of neighbouring countries with smaller renewable energy assets. Biomass surpluses (plantations of residues) that may be used for energy purposes are found in agricultural export countries such as France, Denmark, and possibly more Mediterranean countries that currently are characterised by fairly low photo-synthesis efficiency. The Danish scenario thus differs from that of the sustainable scenario by having substantial renewable energy production for export, just as the domestic demand is higher, e.g. in the transportation sector, due to the market driven development.



### DANISH PRIMARY ENERGY IN FAIR MARKET SCENARIO

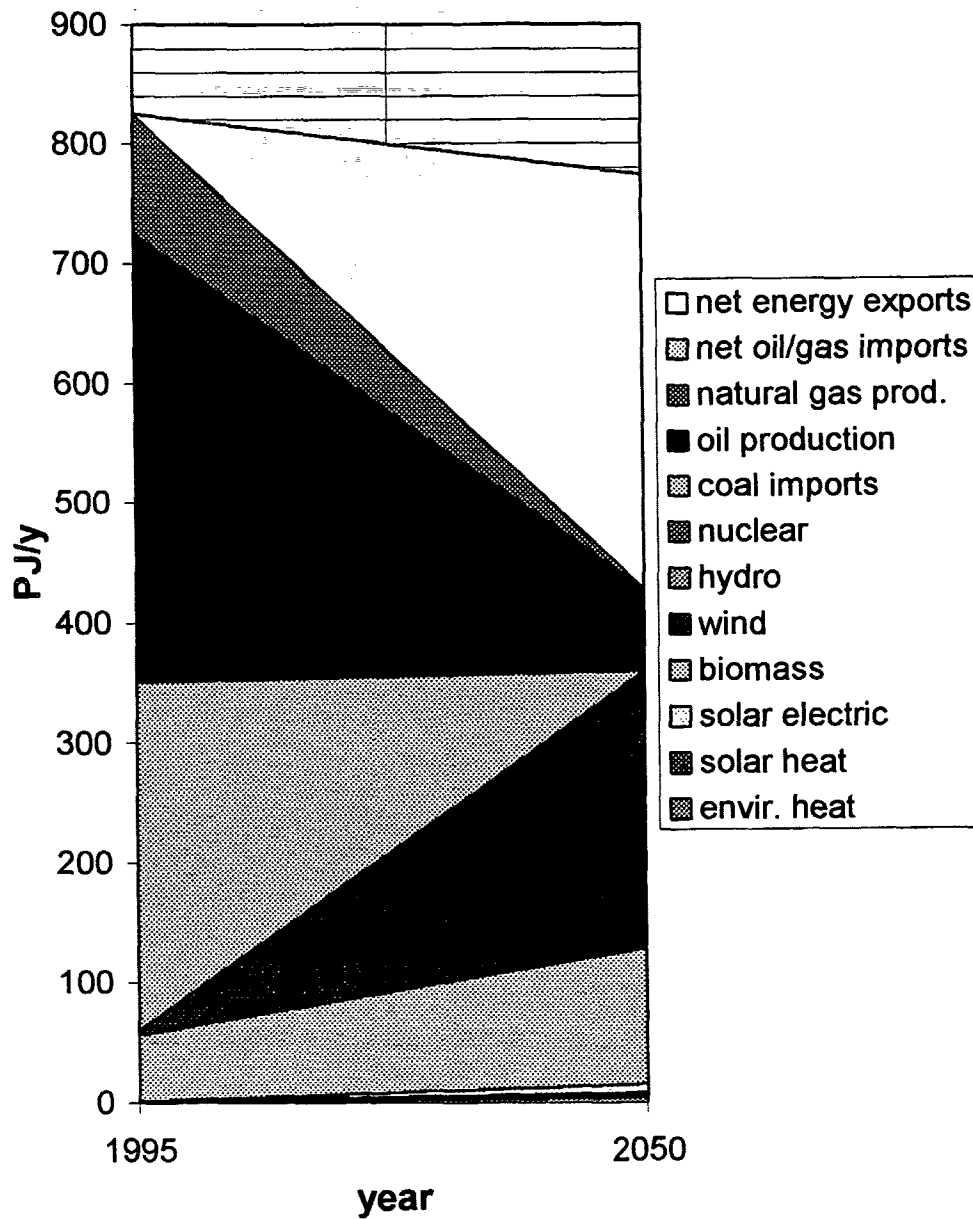

Figure 13. Primary energy end-points of Danish part of the Fair market scenario.

### PRIMARY ENERGY IN EUROPEAN UNION FAIR MARKET SCENARIO

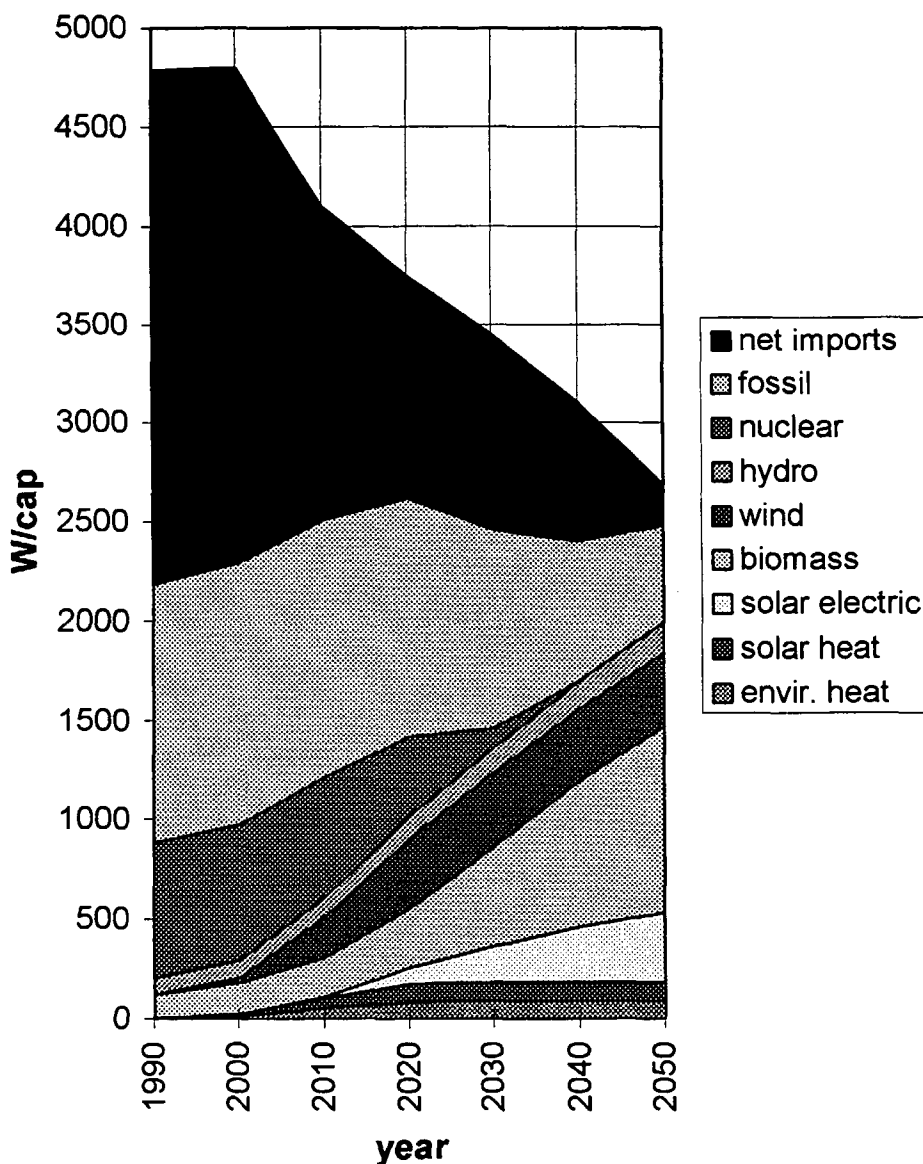

Figure 14. Primary energy supply of the Fair market scenario for the current 15 European Union member countries (Nielsen and Sørensen, 1996).

In order to verify, that the selection of energy storage facilities and import/export options is sufficient to accommodate the intermittent renewable energy generators into the system and still meet demand at all times, an hourly simulation of the system was performed for the 2050 fair market scenario. It shows, as indicated in Table 6 and Figure 19, that there is an electricity deficit (that can be taken care of by import as indicated in Figure 18) and also a heat deficit, which as shown in the hourly simulations (Figure 20 and 21) occurs in winter. The problem is no greater than it can be taken care of by using oil-fired boilers during the heat deficit hours,

mainly feeding into district heating lines. The amount of fossil fuel needed for this is still within the limit that allows greenhouse emissions to decrease to 20% of the present ones, as indicated in Table 7 based on an alternative simulation adding 500 W/cap. of oil to the scenario, Alternatively, additional biomass may be used in boilers.

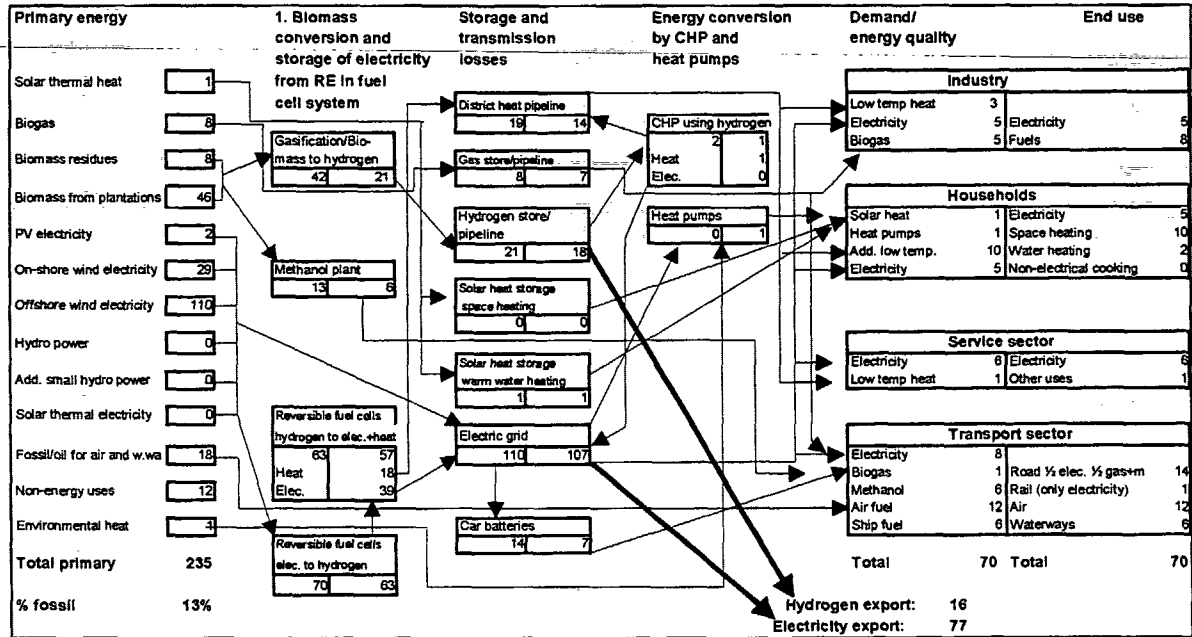

Figure 15. Conversion system of the Danish part of the fair market scenario for year 2050. The unit is TWh/y (Nielsen and Sørensen, 1996).

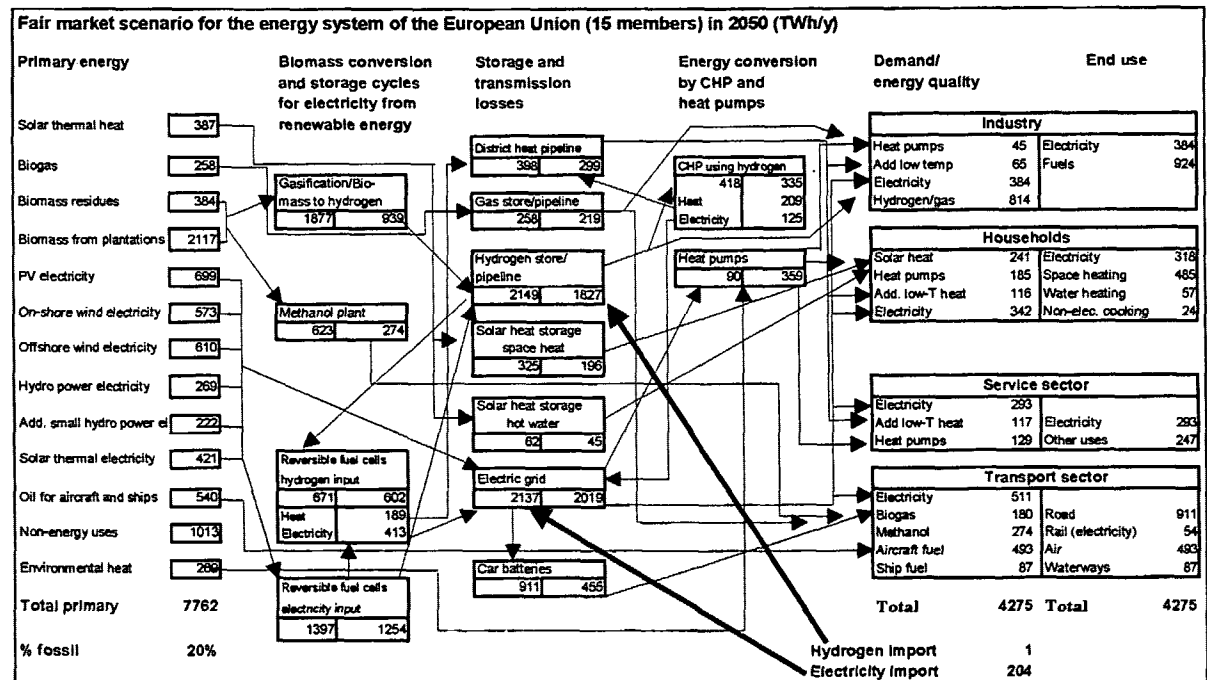
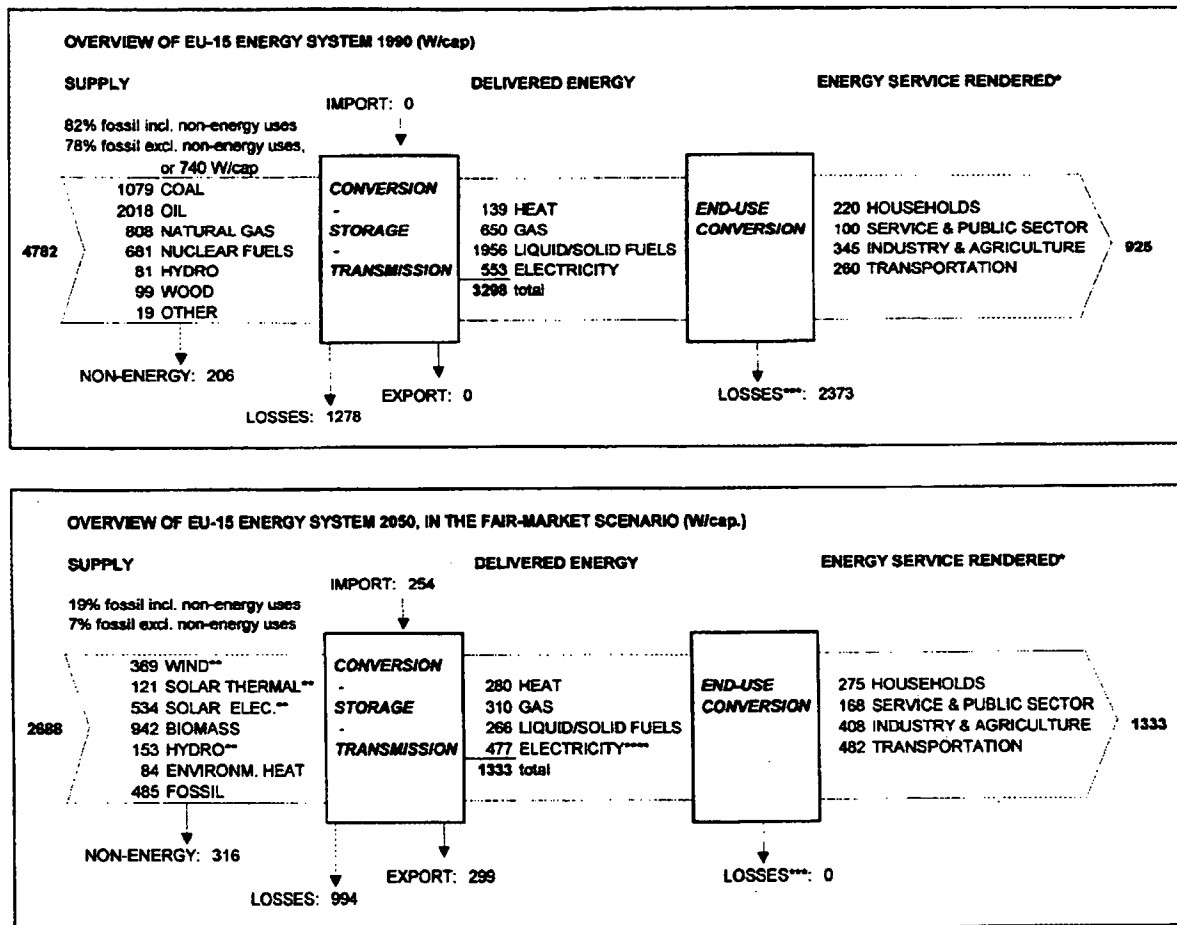

Figure 16. Summary of conversion system for the 2050 fair market scenario of the 15 current European Union member countries. Unit: TWh/y. (Nielsen and Sørensen, 1996).



\* Defined as delivered energy, had the best currently known technology been used (as it is assumed to be in 2050). This makes the 1990 and 2050 service levels directly comparable.  
 \*\* Hydro, solar and wind energy is counted as heat or electricity produced.  
 \*\*\* Losses in end-use conversion are counted relative to a given technology level (see note \* above).

Figure 17. Overview of the EU-15 fair market scenario in 1990 and 2050 (W/cap.)

The fair market scenario is thus a fairly thoroughly checked worked though picture of a future, that may come true provided that the prices of energy commodities are made to include externalities to the extend assumed in the underlying estimate of monetised LCA impacts, and provided that customers on the energy market behave “rationally”, an assumption underlying any conventional market theory. In this case “rationality” means that the actors in the marketplace has both enough knowledge and will to select the most cost-effective solutions. In the past, this has not always been the case, particularly as regards implementing energy efficiency measures that were cheaper than continuing ongoing practices. The possible reason for this may be non-economic barriers facing the actors, and the realisation of the fair market scenario may thus require government action to ensure, that the optimum economic solutions are indeed chosen.

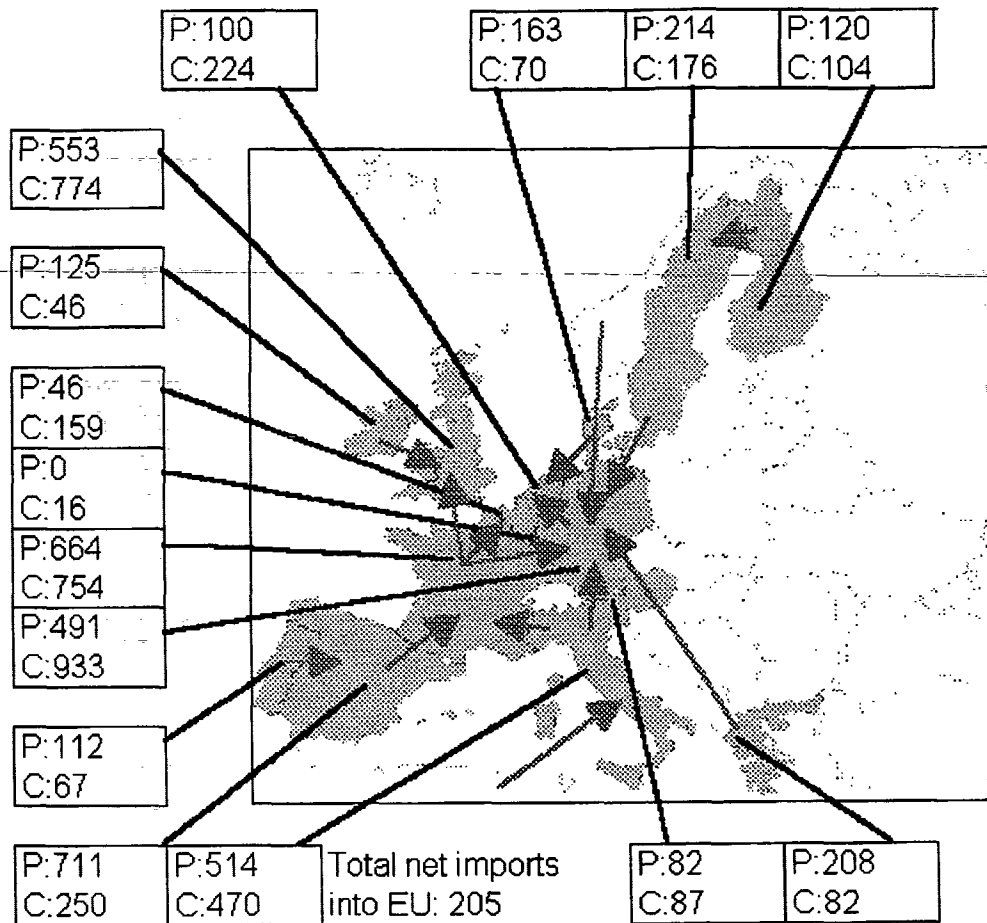

**OVERVIEW OF 2050 FAIR MARKET SCENARIO FOR EU15**

Net production (P) and end-use consumption (C) in TWh/y

Figure 18. Overview of 2050 fair market scenario and indication of major import and export energy trade. The import from regions outside EU-15 include partners such as Norway, North Africa and the Middle East (Nielsen and Sørensen, 1997).

Another factor is that the LCA costs associated with the fair market scenario are based on certain assumptions, especially regarding the monetising procedure used. These will be examined further in the following chapter.

E.form	deficit	surplus	min.prod.	max. prod.	ctual prod.	load	fuel cell	CHP	furnace	boiler	heat pump
low-T heat	169	16	69	196	121	382	0	0	0	0	0
high-T heat	0	0	0	0	0	0	0	0	0	0	0
electricity	85	283	793	944	860	652	15	0	0	0	17
gaseous fuels	2	0	113	410	385	367	24	0	0	9	0
liquid fuels	0	0	0	339	293	266	0	21	0	6	0

Table 6. Annual summary of fair market scenario 2050 hourly simulation runs (Sørensen, 1996).

E.form	deficit	surplus	min.prod.	max. prod.	actual prod.	load	fuel cell	CHP	furnace	boiler	heat pump
low-T heat	3	41	69	196	121	382	0	0	0	0	0
high-T heat	0	0	0	0	0	0	0	0	0	0	0
electricity	23	283	793	944	860	652	15	0	0	0	17
gaseous fuels	2	0	113	410	385	367	24	0	0	9	0
liquid fuels	0	0	0	1515	596	266	0	229	0	101	0

Table 7. Annual summary of a special fair market scenario 2050 hourly simulation run with extra fossil fuel used e.g. in CHP plants (Sørensen, 1996).

Annual summary

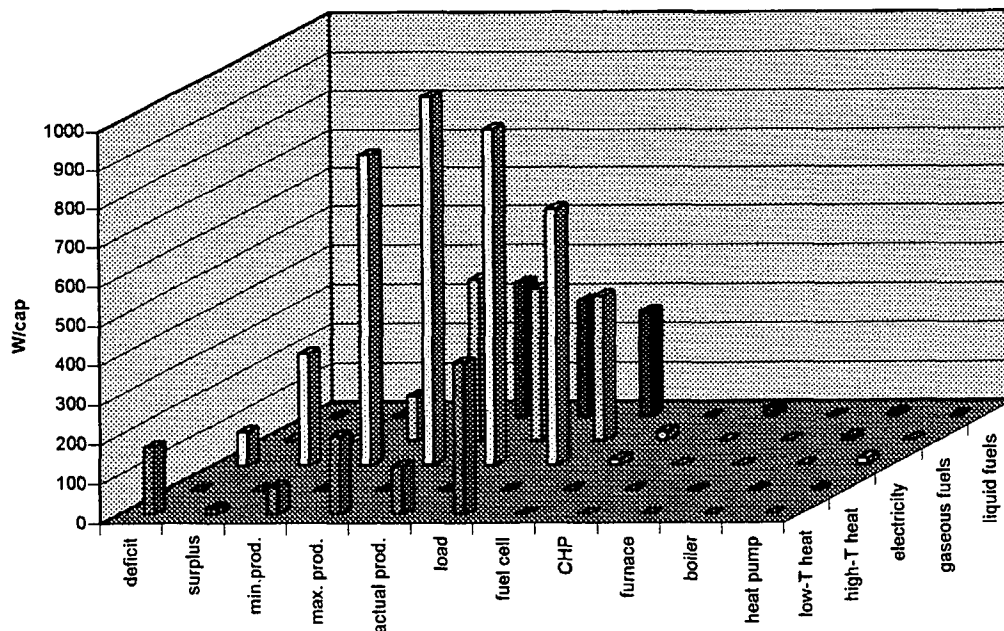

Figure 19. Summary of hourly simulations throughout one year for the 2050 fair market scenario (numbers given in Table 6). The 5 rightmost columns represent conversions to the energy form mentioned, whereas the column labelled "actual production" is representing direct production of the energy form in question. The minimum and maximum production possible by the system is also indicated. The columns labelled "deficit" and "surplus" are needs for import or export options, as counted after all energy conversion has taken place (Sørensen, 1997).

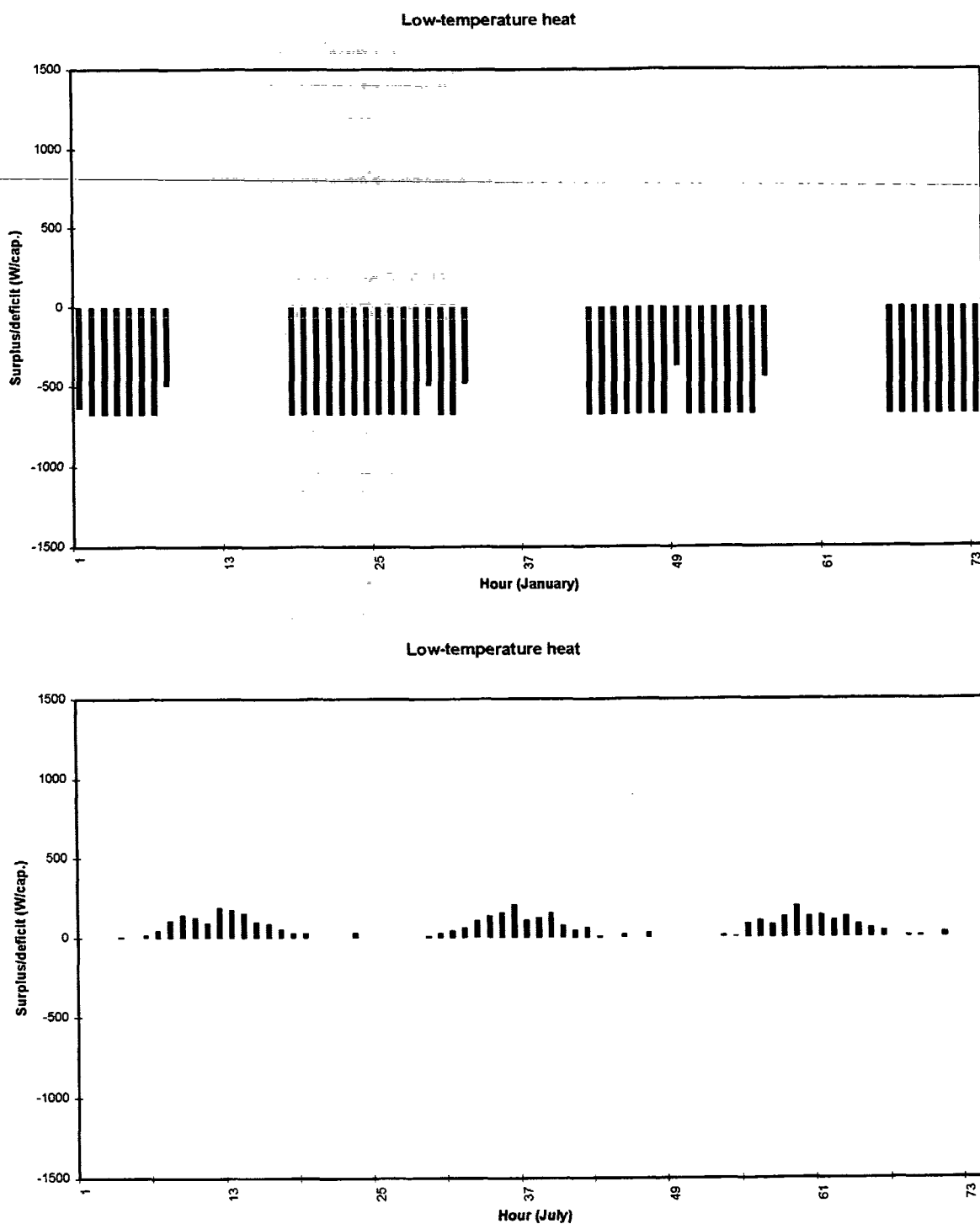

Figure 20. Simulation results for the 2050 fair market scenario heat balance during some winter and summer hours (Sørensen, 1997).

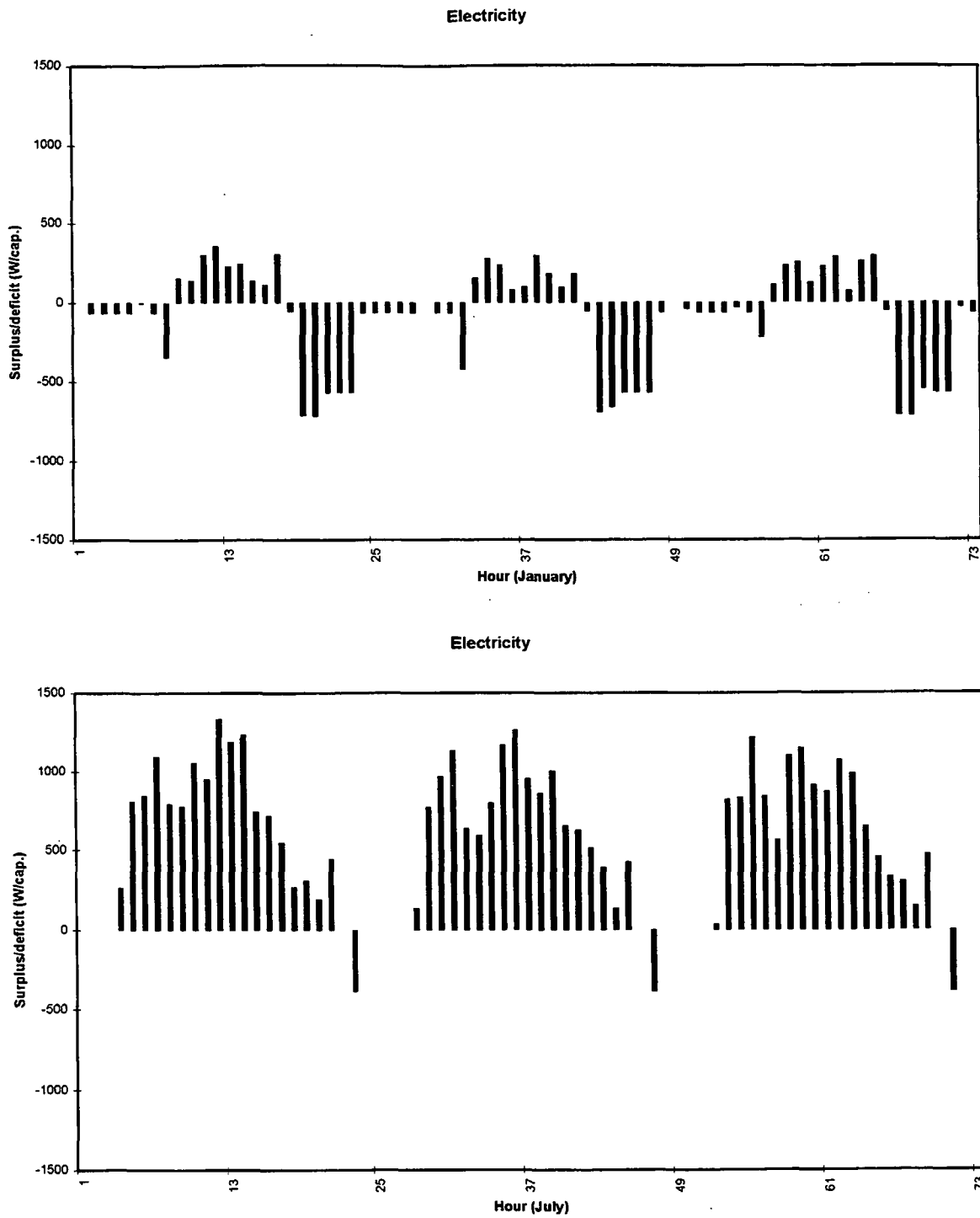

Figure 21. Simulation results for the 2050 fair market scenario electricity balance during some winter and summer hours (Sørensen, 1997).



#### 4. SELECTING DATA FOR THE LIFE-CYCLE ANALYSIS

The energy system components to consider in the LCA comprise extraction of energy, transport of fuels to the first conversion step, then possibly further transport or transmission to any following conversion steps, and so on, until the final energy form is reaching a consumer, be it a household, a service provider or an industry, for the end-use transformation into a demanded good or service.

For keeping track of all the LCA impacts within the energy system LCA impacts, we use a simple housekeeping computer program TEMIS (GEMIS, 1992; TEMIS, 1993; Fritsche *et al.*, 1989), capable of including the indirect LCA in what resembles the input-output models used in conventional economic analysis. The reason that this needs a special program rather than just a spreadsheet is, that there are circular calculations, when the indirect inputs to a particular life-cycle step include e.g. electricity deriving from another component of the energy system, that again may be linked to the first one. Such loop calculations are not allowed in spreadsheets. However, we do use a small spreadsheet program with the TEMIS output as input to investigate the double-counting and import-export issues raised in Chapter 2.

Because we are dealing with energy system LCA and not product LCA we ideally have, in order to avoid double counting, to reduce the total final end-use energy by the energy consumed for manufacturing the products used along the energy chains. However, as the energy used for producing energy equipment such as wind turbines is a small fraction of the total Danish energy use, we have not done this. Instead, we assume that the impacts from materials and parts used to produce wind turbines, power plants etc. take place outside Denmark. As we are going to calculate impacts both with and without those associated with imported goods, we therefore obtain an indication of the importance of such indirect impacts. The actual import fraction of equipment produced in Denmark is slightly over 50%.

The following subsections give a survey of impacts included, the data used for LCA impacts and their monetarisation, including an important discussion of the selected numerical value of the important parameter called the "Statistical value of life" (SVL). We follow the usual practice of restricting ourselves to what is believed to be the most important impacts. This means that a full LCA including indirect impacts is performed only where such impacts are believed to dominate, e.g. for most renewable energy conversion systems. For conventional fuel based systems such as those for electricity production, the indirect impacts are believed to be orders of magnitude smaller than the dominating ones from greenhouse gases and pollutants, and therefore we do a conventional chain analysis, neglecting impacts occurring during the manufacture of equipment and inputs of materials. In studies such as the ExternE, these are being referred to as "externalities", although no serious attempt is being made to find out, if part of them may be reflected in prices (e.g. by coal miners receiving higher salaries due to the risk of the profession or by current taxation of fuels). Our point of view is to attempt to determine all important impacts, without discussing at this stage their incorporation in prices. This issue is pursued in the fair market scenario. The figures given in this chapter are meant to represent full impacts of the types considered. They would in this context have to be supplemented with positive impacts, such as the benefits derived from using energy. This point of view is further elaborated in other connections (Sørensen, 1996).

#### 4.1 Impact types included

Several impacts were identified in chapter 2 as possibly arising from the life-cycle analysis of an energy system. In this study we concentrate on impacts that we feel confident about quantifying, as a basis for translating into monetary impacts. They are the well-mapped direct emissions to the air, like of SO<sub>2</sub>, NO<sub>x</sub> and CO<sub>2</sub>, and impacts from activities (e.g. work accidents occurring during construction of equipment, or transportation of goods and personnel). These impacts are fairly well described today, and they occur for all the technologies that we have considered (however, for renewable energy technologies the emissions are mainly from fossil fuels presently used in construction - these will diminish as the energy supply system acquires a higher percentage of renewables).

A few impacts are specific to certain technologies. One is the release of ozone-destructive substances, which at least in the past have occurred during production of electronics compounds, and thus may apply to PV cell production, unless new techniques are employed.

We first give an overview of all the types of impacts included:

##### Greenhouse warming impacts

Our main sources of data, such as the ExternE project, do not estimate greenhouse warming impacts, but only quotes some older literature estimates. Because of the increased insight into the nature of impacts obtained during the recent work in the Intergovernmental Climate Panel, we are able to evaluate impacts specifically for this study that we believe are of a better quality than any data found in the earlier literature. Emissions are characterised by their global warming potential (GWP) (IPCC I, 1996). The individual sources are the following:

**CO<sub>2</sub>**: Carbon dioxide is the most important greenhouse gas, currently contributing more than half to the enhanced greenhouse effect. We differentiate between CO<sub>2</sub> emitted from biogenic and fossil sources. For the former, emissions are not counted, as they are assumed to belong to a closed, sustainable loop, from the assimilation by plants to the release by combustion or other use. This is an approximation, as there may be considerable delays between assimilation and release, causing temporal impact fluctuations. However, our CO<sub>2</sub> impact calculations are limited to the contributions from fossil fuels.

**CH<sub>4</sub>**: Like CO<sub>2</sub>, methane is also part of the biological cycle. There are large differences, though. First the major source of CH<sub>4</sub> is not the burning of fossil fuels, although some of it may be liberated during such processes, or in upstream stages, like from the production of coal. The most significant current sources of CH<sub>4</sub> in the energy sector are leaks from natural gas pipelines, gas extraction and treatment plants, coal mining and biogas plants, and emissions from the decomposition of organic material in hydropower reservoirs. Especially for tropical hydropower installations this is the case, but also for the Scandinavian hydro power reservoirs there is an impact. Outside the energy sector, animal husbandry is the major cause of CH<sub>4</sub> emissions. In the future, the integrated use of animal raising for food and energy needs (e.g. through the use of manure or other wastes for energy purposes) would require some kind of division of the impacts between the food and energy sectors. We divide this according to the revenue derived by the farmer from selling food and energy products. A simple estimate of the CH<sub>4</sub> emissions from animal husbandry was made. Although the biogenic CH<sub>4</sub> emissions is a neutral part of the biological carbon cycle, the fact that methane has a much higher global warming potential (21 times higher for a 100 year horizon, according to IPCC I (1995)) than carbon dioxide potentially makes it more important to consider the time variations in

greenhouse impacts caused by methane than for CO<sub>2</sub>. We have not been able to do this, because we consider only integrated greenhouse impacts over the next century.

*N<sub>2</sub>O*: Nitrous oxide, N<sub>2</sub>O, is a greenhouse precursor gas. This gas is emitted when burning fossil fuels and may also play a role for biomass plantations, as a result of the nitrification of nitrogen fertiliser. Again the whole nitrogen cycle should be considered, and the contributions that are not part of a sustainable cycle be included as impacts. We do this in the same way as for CH<sub>4</sub>.

*CO*: The health impacts of the emissions of carbon monoxide are not treated explicitly in this study, but its global warming impacts has been included.

The contributions of greenhouse gases other than CO<sub>2</sub> can be expressed as an equivalent amount of CO<sub>2</sub>. The differences in lifetime in the atmosphere and in warming potential makes this possible only for overall estimations of the greenhouse impacts over a long period of time, such as the hundred year period used in this study. To compute the CO<sub>2</sub> equivalents we have used the relative GWP factors given in Table 8, taken from IPCC I (1996), but for NMVOC the value is from GEMIS (1992).

We have not assessed any negative GWP value that may pertain to particle emissions and SO<sub>2</sub> emissions (subsequently being transformed into sulphate aerosols), as we think that such emissions are being and will be strongly reduced over a much shorter time frame than our scenario considers, due to their other environmental impacts (acid rain). If we should take this development into consideration, the expected effect of SO<sub>2</sub> would be a near-term *positive* impact on regional warming.

We have not included any greenhouse impacts from HCl or HF emissions associated with current fossil fuel or waste burning, because we have no data on their possible GWP's,

**Table 8. GWP factors for different greenhouse gases considered in this study**

substance	relative GWP factor
SO <sub>2</sub>	0
CH <sub>4</sub>	27
CO	3
NO <sub>x</sub>	8
Particles.	-
HCl	-
HF	-
NMVOC	11
N <sub>2</sub> O	350

### Impacts from air pollution

**NM VOC:** Non-methane volatile organic compounds (VOC), also called non-methane hydrocarbons (NMHC), are of importance together with nitrogen oxides (see below) in the formation of low tropospheric ozone. Their emissions are included for several fossil technologies, and as an incremental effect from biomass plantations (using Meyer *et al.*, 1994, p. 103; cf. our discussion of biomass in the technology appendix). Organic compounds are being used in several industries, as solvents or for a series of other purposes. They are subsequently emitted either during production (e.g. of blades for wind turbines), where today they are normally vented. In some cases, they stay in the product and evaporate during its use. In both cases they can impact on the outside environment or people. In the atmosphere they can lead to increased ozone creation, and if ingested by people to physiological damages. We include these impacts according to the TEMIS estimate of the impact (TEMIS, 1993).

**SO<sub>2</sub> :** Sulphur dioxide, SO<sub>2</sub>, is an important contributor to acidification of the environment. Its emissions are already regulated and down-going, and further emission reductions are planned. Still, the acidity of precipitation in Europe is only changing slowly, as a consequence of another effect: the decline of cations that oppose the acidifying actions of SO<sub>2</sub> and NO<sub>x</sub> emissions (Hedin *et al.*, 1994). The ExternE project (European Commission, 1995a) describes the impacts from SO<sub>2</sub> directly, and indirectly following the creation of particles<sup>1</sup>, on local (up to about 50 kilometres from the emitter) and regional scale (several hundreds of kilometres). For power stations with their high stacks it was found that the most important impacts actually occur on the regional scale, where concentrations are much smaller but the impacted population size much larger than nearer to the source.

This is very much a result of the linear dose-response relationships that have been applied in the ExternE project. Calculation of SO<sub>2</sub> oxidation and the creation of sulphate particles is rather straightforward, and concentrations of e.g. PM<sub>10</sub> depend linearly on the emissions. Therefore we argue that we can scale the effects calculated by the ExternE study on public morbidity and mortality from sulphur particles simply by the differences in actual emissions between the sites used in the ExternE study and Denmark, but we do correct for differences in population density between Western Europe, where most of the emissions from the investigated power stations of Lauffen and West Burton would fall down, and Northern Europe, where the emissions from Danish sources would primarily impact.

The emissions from fossil fuel sources such as oil fired heat boilers or automobile exhausts comprise roughly the same substances as the emissions from large power plants, and we simply adjust the effects by the amounts of emissions. This, however, does not capture all the differences, and particularly the fact that these other emissions occur at much lower heights may imply additional health effects.

---

<sup>1</sup> Those particles are called PM<sub>10</sub> and PM<sub>2.5</sub> depending on their aerodynamic diameter of up to 10 or 2.5 micro-metres (10<sup>-6</sup> m). It has recently been found that PM<sub>2.5</sub> actually are the most important and dangerous ones (Anonymous, 1996), but the ExternE work concentrated on PM<sub>10</sub>. It is possible to estimate the concentration of PM<sub>2.5</sub> by multiplying the PM<sub>10</sub> concentration with a constant factor.

We have not monetised agricultural and forestry damages from the above emissions explicitly. This may soon be possible using the program *EcoSense* developed as part of the ExternE project, but as yet not completed. The preliminary expectation is that the monetised costs of damages to agriculture and natural ecosystems will be much smaller than the public health that we include.

**NO<sub>x</sub>:** Nitrogen oxides play a role in both acidification and ozone chemistry in the lower atmosphere. With respect to the first its impacts have been described, and plans to reduce its emissions have been proposed. With regard to the latter we refer to the paragraph on ozone below. We do include the public health impacts from NO<sub>x</sub> arising from the creation of suspended particles and their impact on the pulmonary respiratory system of humans, using the dose-response function estimated by the ExternE study (European Commission, 1995c, p. 104).

**O<sub>3</sub>:** Ozone is normally not emitted in major amounts by human activities. NO<sub>x</sub> and VOC play a role in ozone chemistry in the lower atmosphere, and the dose-response relationship with regard to the latter is non-linear. Primary emissions of NO get oxidised to NO<sub>2</sub> some hours after the release. This process actually consumes some of the ozone that is found in the air, therefore in power station plumes near to the source the concentrations of O<sub>3</sub> are lower than in the surrounding air (European Commission 1995c, p. 117). Ozone concentrations also very much depend on emissions of VOC, including those from natural sources, and no simple relationships can be given.

Bastrup-Birk *et al.* (private communication) have described a series of model experiments with changing NO<sub>x</sub> and VOC emissions. It was found that ozone concentrations over Europe depend very non-linearly on emissions and that therefore no simple advice can be given on ways to reduce the general ozone load of the lower atmosphere. We have therefore not been able to include a description of this substance and its impacts in our study. The US counterpart of the ExternE study looks at ozone and find very large externality contributions, but with equally large uncertainties (USDOE, 1994).

### Land use impacts

The area demand of energy systems is an impact that we have been able to include. Area demands of technologies such as open coal mines and biomass plantation can be very large. Compared to the current fossil technologies we do expect the area demand to grow in the future energy systems, for the same amount of primary energy. On the other hand we know that the two future scenarios considered are implying much more efficient energy chains, and that therefore they will be needing much less primary energy than the present system, for the same end-use energy services.

Still, the area demand will be important for two reasons: One is that Denmark's physical area is fairly limited and has to be shared between habitation, traditional agricultural and other activities. The alternative of importing more biomass, should it be feasible, might increase global problems. Increased area use for agriculture will reduce natural vegetation, which among other effects may reduce biodiversity.

We have investigated the literature on biodiversity (Pearce and Puroshothaman, 1995; Marjorie *et al.*, 1996) but find the impact estimates too uncertain to include in a quantitative way.

## Impact on groundwater resources

Water is becoming a scarce resource all over the World. In some places there is already insufficient supply, leading to restrictions on economic development, and more such cases are expected to emerge. In our analysis of energy systems, we have tried to estimate the consequences of upstream activities such as minerals extraction on groundwater use or spills.

For open coal mining, groundwater is being extracted as a part of the process, in order to diminish the water content of the extracted coal. This water in many cases is polluted with salts or cannot be made useful due to lack of potential consumers near the production site. The groundwater extracted thus represents an impact on the environment caused by the energy extraction activity, and we have associated it with an "equivalent groundwater emission" factor. The purpose of this indicator is mainly to indicate the size of the problem.

## 4.2 Pathway calculations

In order to translate the emissions into health effects, most LCA and externality studies make use of the pathway method (see e.g. European Commission, 1995b), as illustrated in Figure 22. The first step consists of running a dispersion model that uses emissions from point sources or area sources as input, and calculates air concentration and land deposition as function of place and time. An example is the RAINS model used to calculate SO<sub>2</sub> dispersal on the basis of long-term average meteorological data, aggregated with the help of a large number of trajectory calculations (Alcamo, Shaw and Hordijk, 1990; Hordijk, 1991; Amann and Dhoondia, 1994). In the ExternE project, a range of models were used, ranging from simple Gaussian plume models to trajectory models based on a standard European grid approximation (European Commission, 1995b-e), with different choices of maximum distance.

Based on the output from the dispersion model, ingestion rates and other uptake routes are used to calculate human intake of pollutants through breathing air, skin etc. The next pathway step is a model of disposition in the human body, with emphasis of accumulating organs and rates of excretion. The result is a concentration for each substance and its relevant depository organs. Finally, a dose-response function is used to calculate the morbidity and mortality arising from the human uptake of pollution. It is customary to use a linear dose-response function extending down to (0,0), in cases where measurements only give information on the effects for high doses. This has been done in the ExternE study, based on a precautionary point of view as well as theoretical considerations supporting the linear relation (European Commission, 1995b,c and e). The alternative of assuming a lower threshold, below which there is no effect, is often used in regulatory schemes, usually as a result of industry pressure rather than scientific evidence.

We have not performed independent pathway calculations in this project, but rely on results taken from the literature, and particularly the ExternE study. These results are typically expressed as number of cases (of a health problem or death) per unit of energy produced by a particular installation, and therefore, they make further assumptions regarding the technology used for energy conversion and on the population distribution around the energy facility. For example, the ExternE coal-fired power plants are at two specific locations in the UK and Germany (West Burton and Lauffen), using local coal and representing particular stack cleaning technology. For Denmark, most coal-fired power stations are co-producing heat for

district heating lines, they use coal from other parts of the world, and finally the population density at various distances around the Danish CHP plants is different from those used in the ExternE study. We have therefore employed a Danish adaptation of the ExternE calculation, where emission factors were adjusted to the Danish situation and dispersion calculations were remade for the meteorological conditions in and around Denmark (Warming, 1996). Also adjustments for the lower population density in Northern Europe as compared to Central Europe were made.

### 4.3 Monetising the impacts

The translation of impacts from physical terms (number of health effects, amount of building damage, number of people affected by noise, etc.) to monetary terms (DKr/PJ, ECU/kWh, etc.) is in the ExternE project proposed to be carried out by a study of the affected population's willingness to pay (WTP) for avoiding the impacts. This means that ExternE does not aim at estimating the cost to society, but rather the sum of costs afflicted on individual citizens. The WTP concept has a number of inherent problems:

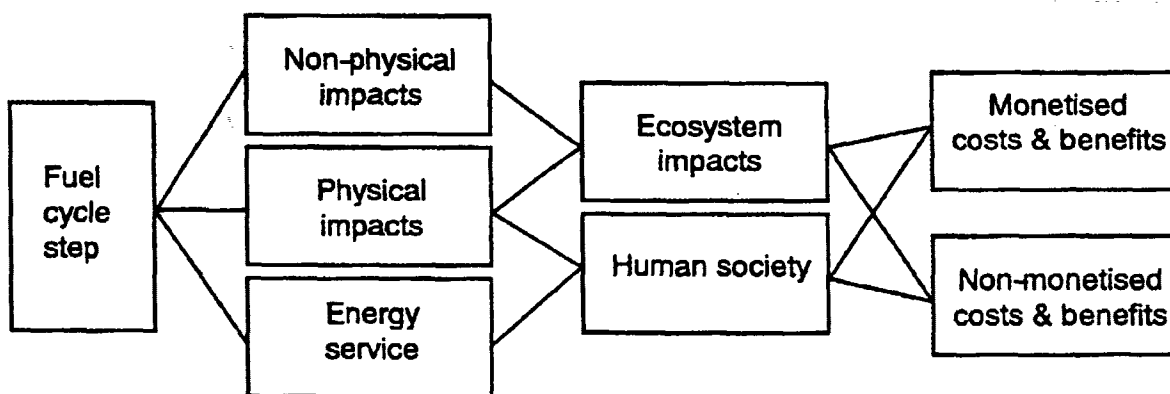

E.g.:

emissions → dispersal → level/concentration → dose-response → valuation → cost

Figure 22. Illustration of pathway method for evaluating externalities (Sørensen, 1996d).

- Interview studies may lead people to quote higher amounts than they would pay in an actual case.
- The resulting WTP's will depend on disposable income.
- The resulting WTP's will depend on the level of knowledge of the workings of the impacts in question.

The outcome of an actual development governed by the WTP principle may be inconsistent with agreed social goals of equity and fairness, as it may lead to polluting installations being built in the socially poorest areas.

The accidental deaths associated with energy provision turns out to be the most significant impact, fairly independent of details in the monetising procedure selected. We shall therefore deal with choice of the monetised value of an additional death caused by the energy system in a

little more detail below. At this point it should only be said, that our aim is to work with a monetised damage reflecting the full LCA cost of energy to society, rather than the cost to individual citizens with different outlooks. The next sub-sections will state the monetised damage figures that we actually use and our evaluation of the uncertainties involved in using these values.

### Statistical value of life

In calculating externalities, the ExternE project uses the value of 2.6 MECU to monetise the loss of a life. This value is based on a survey of three types of data:

- Willingness to accept a higher risk of death, as revealed by salary increases in risky jobs as compared with similar jobs with small risk.
- Contingency valuation studies, i.e. interviews aimed at getting statements of WTP for risks of death.
- Actual expenditures paid to reduce risk of loss of life (e.g. purchase of automobile air bags, anti-smoking medication, etc.).

Compensations paid by European governments to families of civil servants dying in connection with their job were also considered by the ExternE group. The scatter in data reviewed ranged from 0.3 to 16 MECU per death.

A feeling for the statistical value of life (SVL) can be obtained by considering the salary lost by accidental death. If we assume that the death on average occurs at the middle of working life and calculate the total salary that would have been earned during the remaining time to retirement, one would in Denmark get a little over 20 years multiplied by the average salary for the high seniority part of a work career, amounting to between 300000 and 400000 DKr per year, or around 8 MDKr (1.14 MECU). If this was paid to an individual, it should be corrected for interest earning by giving the corresponding present value of annual payments of about 60 kECU/y over 20 years. However, as a cost to society, it may be argued that no discounting should take place, because society does not set money aside for future salary payments.

Two other arguments might be considered. One is that in times of unemployment, the social value of a person fit to work may be less than the potential salary. The other is that the members of a society have a value to that society above their ability to work. If this was not the case, a society would not provide health services that prolong people's lives beyond retirement age. The judgement on the merits of these arguments would lead us to conclude, that the SVL for society is more than 8 MDKr, but not how much more. One could say that the ExternE value of 2.6 MECU represents a fairly generous estimate of non-tangible values to society of its members, and that half that value may be easier to defend. However, as stated above, the ExternE estimate has an entirely different basis, representing an individual SVL rather than one seen from the point of view of society.

One further consideration is that not all deaths associated with say Danish use of energy take place in Denmark. If coal are imported from Bolivia, coal mining deaths would occur there, and the question arises if a smaller value of life should be used in that case, reflecting the lower salary earnings in Bolivia (and perhaps a smaller concern by society). This would easily be stamped as a colonial view, and ExternE has clearly opted to use the same SVL no matter where in the World the death occurs. This is one reason that the concept of SVL has been



attacked. Another is the ethical problem of putting a value on a human life. The reply to the latter should be that SVL may just be a poorly chosen name selected for the attempt to give the political decision-process a clear signal (read: in monetary units) regarding the importance of considering accidental death. This debate over the use of SVL was recently exhibited in the journal *Nature*, in connection with the greenhouse warming issue (Grubb, 1996).

We have chosen in this study to use the ExternE SVL monetised value of 2.6 MECU/death, in order to make our results comparable with those of the ExternE work, as the most recent and most detailed effort in the field. The discussion above leads us to believe that if this SVL is on the high side, it is so by at most a factor of two.

### Morbidity and other impacts

ExternE differentiates between occupational and public mortality and morbidity. Data for occupational morbidity are available, e.g. for coal miners. The health impacts from solvents (as e.g. used in the photovoltaic industry) and work environment are factors that might become dominant in future energy systems, but are difficult to quantify today. Also dust from the handling of straw bales in energy installations or the transport of dust releasing biomass could have impacts on occupational morbidity. These contributions are not included in the ExternE data, and only rough estimates obtained from broad current industry groups may be substituted, as they have been e.g. in the wind energy study (European Commission, 1995f).

The impacts on public morbidity have in ExternE been derived from measured dose response relationships published in several clinical studies (European Commission, 1995c, pp. 107 ff.) by taking the endpoints and interpolating linearly between them. For the different impacts the values given in Table 9 are used:

**Table 9. Monetary valuation of different health damages (European Commission, 1995b)**

Health effect	ECU per case
Mortality	2600000
Respiratory hospital admissions, including treatment for respiratory infections, chronic pulmonary diseases and asthma	6600
Emergency room visit, including treatment for chronic obstructive pulmonary diseases, asthma and childhood croup	186
Bronchitis	138
Days of restricted activity	62
Asthma attacks	31
Symptom days	6

#### 4.4 Specific LCA data used.

##### Greenhouse warming impacts

Several studies have tried to estimate the damages that may occur as a consequence of the enhanced greenhouse effect. Most existing studies have concentrated on the damage that may occur in industrialised countries or even specifically in North America (Cline, 1992;

Fankhauser, 1995; Tol, 1995 and Nordhaus 1994; summaries may be found in IPCC III, 1995). Exceptions are the top-down studies of Hohmeyer (1989) and Ottinger (1994), using rather uninformed guesses regarding starvation deaths from climate change.

We shall take advantage of the recent IPCC work (IPCC II, 1995), which gives much more precise information on the expected physical damage caused by global warming. Based on this work we shall make a monetary evaluation using assumptions similar to those of the ExternE study (cf. Sørensen, 1996a). One simplification of this assessment is that the emissions are considered to disperse globally, so that no detailed transport modelling is required. However, the impacts on climate are the results of quite complex climate model calculations, and the geographical distribution of climatic changes is at present considered quite uncertain (say expressed in terms of the localisation of concrete effect such as change in natural vegetation zones or local temperature changes, cf. IPCC I, 1995). Still, the types of impacts that will turn out most important are not strongly dependent on the precise location within some hundreds of kilometres, so as a result the confidence in the impacts that we predict will be fairly high. In addition to the factor two uncertainty in the SVL used, there may be a similar uncertainty in the impacts predicted, provided that the assumptions of the estimate are valid: the estimates are based on business as usual energy use and no specific mitigation responses being made, translating into a doubling of CO<sub>2</sub> by the mid-21<sup>st</sup> century.

One point in making these assumptions is precisely to argue, that the mitigation or avoidance costs are lower than the trend-based damage costs, and this is precisely the basis upon which the alternative scenarios that we are considering is formulated.

The current greenhouse forcing, i.e. the excess flow of energy into the atmosphere, is estimated at 2.5 Wm<sup>-2</sup> (IPCC I, 1995, p. 117), and a doubling of the CO<sub>2</sub> concentration together with a reduction in sulphate aerosols, emerging with the IPCC business as usual scenario (IS92a), is estimated to raise the radiative forcing by 6 Wm<sup>-2</sup> (IPCC I, 1995, p. 320). This is the basis for the evaluation of physical impacts considered by the IPCC impacts and mitigation working group (IPCC II, 1995), that again is the basis for our monetised costs. Impacts are considered as averaged over the 21<sup>st</sup> century and thus assumes that the conceivable variations in greenhouse forcing during the century on average gives the same impacts as a flat doubling of CO<sub>2</sub>.

Table 10 gives a list of impacts identified by the IPCC (IPCC II, 1995), in terms of the additional number of people exposed to a range of risks, due to the average warming, sea level rise and additional extreme events predicted by the climate studies reviewed by the IPCC. As many impacts involve human deaths, the results scale practically linearly with the value of a statistical life used. This means that a choice of a value different from the chosen 3 M US\$ (which is close to the 2.6 MECU used by the ExternE study) can be accommodated as an overall factor.

The individual entries in Table 10 are based on the sources indicated, with magnetization of impacts evaluated in two different ways. The first valuation column uses the high SVL value of 3 M US\$ globally, while the second takes the SVL to be zero for developing countries, in order to display the geographical differences of impacts. Here follows a brief explanation of the impacts included:

Heat-wave deaths occur in major cities due to the heat island effect, possibly combined with urban pollution. The doubling estimated by Kalkstein and Smoyer (1993) is mostly due to

increased occurrence at mid-latitudes (city temperature rise  $2.5^{\circ}$  assumed), and thus two-thirds are assumed to happen in industrialized countries. A case study in New York City (Kalkstein, 1993) finds an increased mortality of  $4 \times 10^{-5}$  over a 5-10 day period. The present annual New York rate of heat wave deaths is 320, and Kalkstein has collected similar numbers for a number of large cities around the world, experiencing days with temperatures above  $33^{\circ}\text{C}$ . The estimated doubling of incidence will thus imply an additional order of magnitude of  $10^5$  heat-wave deaths, annually and globally, valued at 30 T\$ over the 100 year period. Uncertainties come from possible acclimatization effects, and from increased populations in large cities expected over the 21st century.

The doubling of fires causes mainly economic loss, assumed to be evenly distributed between developed and developing countries, whereas the 20% losses of hardwood and fuelwood yields is predicted to follow a complex geographical pattern (Kirschbaum et al, IPCC II, 1995, chapter 1), but with the highest losses occurring in tropical regions (Solomon et al., IPCC II, 1995, chapter 15). It is here assumed that 75% of the economic losses pertains to developing countries. The increased number of skin cancer cases due to an assumed 10% loss of ozone is mainly occurring at higher latitudes (IPCC II, 1995, chapter 18).

Additional allergy cases would be associated with increased levels of pollen and air pollution due to heating and would occur predominantly at lower latitudes, whereas asthma incidence is highest in humid climates, expected to be enhanced at higher latitudes (IPCC II, 1995, chapter 18). The impacts are assumed to be equally divided between developed and developing regions. Due to expected shortfall of hardwood supply relative to demand during the 21st century, the actual economic value may be considerably higher than the estimate given in Table 10. The financial loss associated with a predicted doubling of extreme events (draughts and floods, IPCC II, 1995, chapter 18) is assumed to occur 75% in developing countries. The predicted incidence of insect bites is not valued, but could have an economic impacts, e.g. on livestock production.

One major issue is the impact of climate change on agricultural production. Earlier evaluations (e.g. Hohmeyer, 1988) found food shortage to be the greenhouse impact of highest importance. However, the 1995 IPCC assessment suggests that in developed countries, farmers will be able to adapt crop choices to the slowly changing climate, such that the impacts will be entirely from Third World farmers lacking the skills to adapt. The estimated production loss amounts to 10-30% of current global production (Reilly et al., IPCC II, 1995, chapter 13), increasing the number of people exposed to risk of hunger from the present 640 million to somewhere between 700 and 1000 million (Parry and Rosenzweig, 1993). There are also unexploited possibilities for increasing crop yields in the developing countries, so the outcome will depend on many factors, including speed of technology transfer and development. Assuming a lower estimate of 100 million additional starvation deaths during the 21st century, one arrives at the 300 T\$ figure given in Table 10, all occurring in the Third World. This is also the case for deaths associated with migration induced by extreme events, estimated at 50 million.

The other major impact area is death from diseases transmitted by insect vectors influenced by climatic factors, such as mosquitoes. For Malaria, there are presently 2400 million people at risk (McMichael et al., IPCC II, 1995, chapter 18), and an additional 400 million expected due to greenhouse warming and its implied expansion of the geographical area suited as habitat for

the malaria-carrying mosquitoes (Martens et al, 1994). This will involve subtropical and even some temperate regions, but also in tropical regions, the incidence of malaria is predicted to increase. Assuming 100 million additional deaths from malaria during the 21st century, of which 75% in the tropics, one arrives at the figures given in Table 10. Large uncertainties are associated with the possibilities of mitigating actions in the subtropical and temperate regions. Also for onchocerciasis, vector populations are expected to both increase by 25% at current sites (Mills, 1995) and to spread to new sites (Walsh et al., 1981), leading to 10 million

**Table 10. Estimated global warming impacts during 21st century, for IPCC reference case (CO<sub>2</sub> doubling) (US\$). H: high SVL of 3 M\$ used throughout. L: SVL put at zero for Third World.**

Impact description:	Ref.	Valuation	
		H (T\$)	L (T\$)
Additional heat-wave deaths (doubling, additional 0.1M/y, valued at 3 M\$ each)	a	30	20
Fires due to additional dryspells (doubling)	b	1	0.5
Loss of hardwood- and fuelwood-yields (20% relative to 1980 production)	cde	4	1
Increase in skin-cancer due to UV radiation	b	3	3
Additional asthma and allergy cases (increase in pollen and air pollution due to warming)	b	3	1.5
Financial impact of increase in extreme events (doubling)	b	3	0.8
Increase in insect attacks on livestock and humans	b	?	?
Food production (failure to adopt new crops, increased pests and insect attacks, production loss 10-30%), (population at risk increasing from present 640M to 700-1000M), additional deaths from starvation due to crop loss (100M additional deaths, chiefly in developing countries)	f g	300	0
Deaths connected with migration caused by additional droughts or floods (50M deaths, the affected population being over 300M)	b	150	0
Increased mortality and morbidity due to malaria (presently 2400M at risk and 400M affected, increase due to warming 100M cases, in tropical and partly in subtropical regions, a 7- fold increase potentially possible in temperate regions assumed to be curbed)	b h	300	75
Increased mortality and morbidity due to onchocerciasis (presently 120M at risk and 17.5M affected, increase and spread due to warming 10M additional cases, primarily in developing countries)	b b,i	30	5
Increased mortality and morbidity due to schistosomiasis (presently 600M at risk and 200M cases, increase due to warming 25%, in dev. countries)	b	150	20
Increased mortality and morbidity due to dengue (presently 1800M at risk and 20M cases, increase due to warming 25%, in developing countries)	b b	15	0
Other effects of sanitation and freshwater problems connected with salt water intrusion, droughts, floods and migration (developing countries)	b	50	0
Loss of tourism, socioeconomic problems, loss of species, ecosystem damage, etc.	b	?	?
<b>Total of valued impacts (order of magnitude)</b>		<b>1000</b>	<b>100</b>

Based on discussions in IPCC Working Group II, IPCC II (1995) and on other sources as follows:

- a. Kalkstein and Smoyer (1993)
- b. McMichael et al., in IPCC II (1995), chapter 18.
- c. Zuidema et al. (1994)
- d. Kirschbaum et al., in IPCC II (1995), chapter 1.
- e. Solomon et al., in IPCC II (1995), chapter 15.
- f. Reilly et al., in IPCC II (1995), chapter 13 and Summary for Policymakers
- g. Rosenzweig et al. (1993); Parry and Rosenzweig (1993)
- h. Martens et al. (1994)
- i. Walsh et al. (1981); Mills (1995)

The valuations involve further estimates and should be regarded as very uncertain.

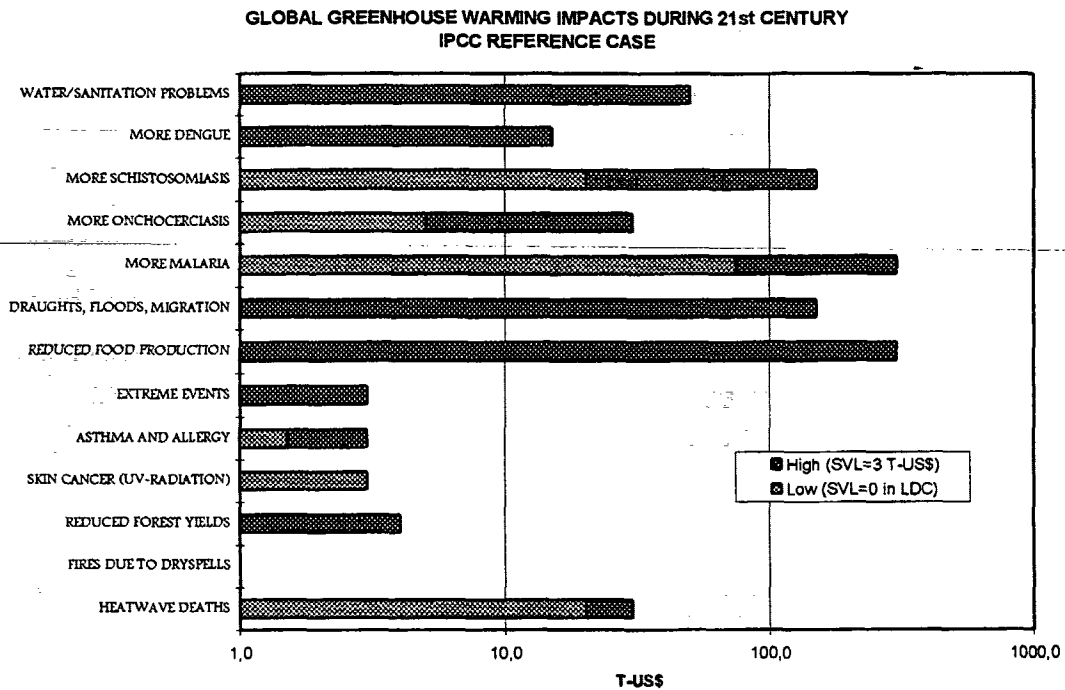

Figure 23. Impacts of global warming, on a logarithmic scale (cf. Table 10).

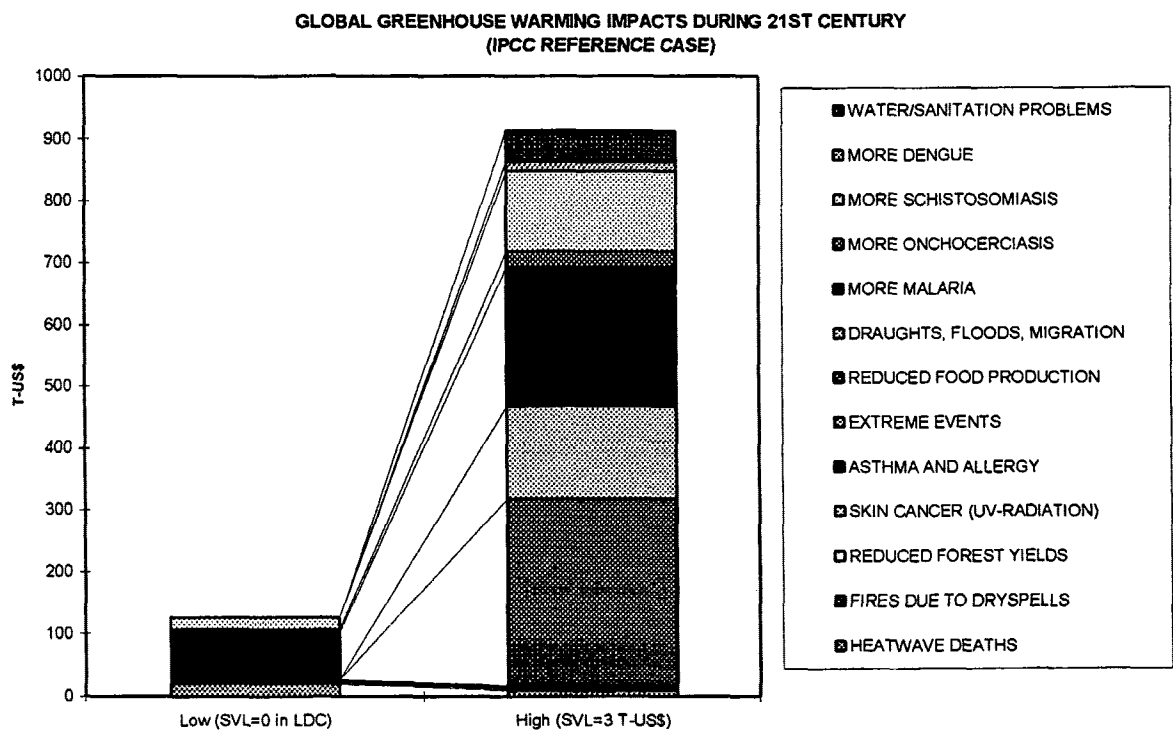

Figure 24. Impacts of global warming, on a linear scale (cf. Table 10).

additional cases. Schistosomiasis may also spread in the subtropical regions, whereas dengue and yellow fever is expected to remain in the tropics. Table 10 reflects these expectations, through its distribution of impacts between developed and developing regions, and it also gives an estimate of deaths occurring due to sanitation problems connected with salt water intrusion into drinking water (due to sea-level rise) and larger migrating populations, mainly in the developing countries (assuming that immigration into industrialized countries continues to be controlled). The economic consequences of other identified impacts, such as loss of species, effect on tourism, etc., have not been estimated.

The overall impacts are of the order of magnitude  $10^{15}$  US \$, when using the SVL of industrialized countries, and one order of magnitude lower, if Third World impacts are valued at or near zero. This spells out the greenhouse impact dilemma, that 90% of the damage is in the Third World, much higher than their share in causing the problem. The IPCC Working Group II identification of a number of impacts specifically occurring in the low-latitude regions explains why the impact estimates are so much higher than those of early work based upon and extrapolated from industrialized regions (Cline, 1992; Frankhauser, 1990; Nordhaus, 1990). Other factors contributing to this result include the high SVL, and the assumptions of less ability to mitigate impacts in the Third World (by switching food crops, building dikes to avoid floods, and so on). If the impacts of the present study, evaluated with the uniform high SVL, are distributed equally over the 100-year period, the annual cost of greenhouse warming is found to be roughly 40% of the current global GNP. Figures 23 and 24 shows the total impacts and the fraction of them occurring outside the Third World.

### **Pollution from power plants**

The results of ExternE for the eight site and technology specific energy chains studied in detail are in aggregated form as shown in Table 11. The areas included in the dispersion calculations of the UK and German studies are different. Due to the use of a linear dose-response function the regional impacts are very important, and the different integration distance explains the higher public health effects found in the German study, which includes regional impacts more than 100 km away from the source.

For the purpose of our study we need to adapt the ExternE results to the conditions set by the Danish energy system, and if possible to supplement by data on those components of the system not investigated in the ExternE project. We use the bottom-up analysis of the electricity producing power plants performed by ExternE as a basis for re-analysing the corresponding Danish facilities. This in part entail correcting for differences in emissions and in population density (which we do by linear scaling, in consideration of the linear dose-response functions assumed), and in part by using a Danish dispersion calculation performed using the ExternE method (ELSAM, 1996). The outcome of this comparison is presented in Table 12.

Table 12 presents the aggregated values for public health and damages on agriculture and natural ecosystems from the Danish study (ELSAM, 1996), according to Varming (1996) based upon a calculation using the *EcoSense* code. It also shows an overview of the public health damages from the emissions for some ExternE calculations. As can be seen, it is impossible to derive the Danish figures from a simple scaling of the values given in the ExternE reports.

**Table 11. Monetised damage estimates from the ExterneE project for the site and technology specific examples of main fuel cycles investigated (mECU/kWh).**

Power chain:	Coal		Lignite	Oil		Gas	Wind	Hydro
Damage Category	UK	DE	DE	DE	DE	UK	UK	NO
Technology				gas turbine	combined cycle			
Public health	4.0*	13.0	10.0	11.0	10.0	0.5*	0.09	NQ
Occupational health – diseases	0.1	0.3	neg.	neg.	neg.	neg.	NQ	neg.
Occupational health – accidents	0.8	2.0	0.1	0.5	0.3	0.1	0.26	3.24E-2
Visual amenity							0.1	
Acid emissions							0.7	
Agriculture	0.03	0.04	0.02	0.04	0.03	NQ		5.45E-2
Forestry	0.004	NQ	0.004	0.013	0.009	neg.		2.5E-4
Water Supply								8.45E-3
Marine Ecosystems	NQ	NQ	NQ	0.2	0.2	0.001		NQ
Materials	1.3	0.1	0.1	0.2	0.1	0.1		NQ
Noise	0.2	NQ	NQ	NQ	NQ	0.03	0.59	neg.
Other Impacts	NQ	NQ	NQ	NQ	NQ	NQ	0.15	
Ferry Traffic								-4.6E-3
Recreational								3.33
Sub-Total	6	15	10	12	11	0.8	1.9	3.42

NQ = not quantified within this report, though some discussion of effects is given.

neg. = negligible.

\*The public health impacts have only been assessed within the UK.

**Table 12. Externality costs evaluated for NO<sub>x</sub>, SO<sub>2</sub> and particulates emissions from a Danish coal-fired power plant (Fynsværket), compared with the selected ExterneE results. (ECU per kg).**

Power chain:	Coal		Coal		Oil		Gas
Emissions	DK	DE	UK	DE	gas turbine-DE	combined cycle-DE	UK
SO <sub>2</sub>	<b>2.29</b>	3.25	1.00	3.00	3.13	3.13	0.28
NO <sub>x</sub>	<b>3.18</b>	9.38	2.99	8.97	9.39	9.40	0.85
Particulates	<b>3.82</b>	12.88	2.90	12.78	15.28	18.44	

Sources: ELSAM (1996), European Commission (1995c,d), supplemented with own calculations.

**Bold frame numbers** are the values given by ELSAM (1996) on the total quantified damages, the figures for the other technologies are computed from the data given in the ExterneE reports.

There are several reasons for this. The Danish valuations for NO<sub>x</sub> and particles emissions are about a third of the German ones, only for SO<sub>2</sub> there is less difference. This is mainly a consequence of the difference in population density in the two regions, but also receives a contribution from the fact, that the German study includes the effect of ozone creation, where NO<sub>x</sub> plays a strong role. Varming (1996) indicates that this is partly included in a 3 to 1 rule of thumb that the German partner of the ExternE project, IER in Stuttgart, uses for evaluating damage potentials from NO<sub>x</sub>, relative to SO<sub>2</sub>, emissions.

Following this argument we use the data published in the ELSAM note for estimating the costs of emitting SO<sub>2</sub>, NO<sub>x</sub> and particulates from Danish power sources. This can also be defended by the quality of the original ExternE data, that themselves are uncertain within a factor of about two (Varming, 1996). This figures already include the damages occurring in agriculture and forestry.

### **Pollution outside the power utility sector**

The externality values given above for the emissions from Danish power stations in principle only apply to large power plants using techniques similar to those used as examples in the study. Because of their high stacks, the emissions are dispersed over a larger area. However, due to the linear dose-response relation assumed, the stack height is of lesser importance, as long as the population density is relatively constant (high doses over a smaller area or lower doses over a larger area).

We would like to use the power station results for other emissions of the same substances, e.g. by industrial or household boilers, and for internal combustion engines used in the transport sector. Typically, these emissions take place at low height, and so the local impact on the environment nearby the source is very important, but the regional impacts may be correspondingly less important. We expect additional health effects to be associated with the nearness of exposure, as also indicated e.g. by Det Økonomiske Råd (1996), but since we have little relevant data to go by, we use the emission-adjusted power plant figures as a first approximation for these other sectors. For the transport sector, there are specific air pollution health impact studies (e.g. Danish Transport Council, 1993), that we have used, as indicated in the special sub-section on transport below. For SO<sub>2</sub>, NO<sub>x</sub> and particles emissions from fossil fuelled district heating plants and furnaces in industry we use the dose-response ratios (damages in mECU per g) for power stations from the Danish ExternE-type investigation (ELSAM, 1996).

District heating lines, power transmission lines as well as end-use conversion equipment involve manufacturing processes and input of materials produced with a range of LCA impacts. In most cases (the personal transportation being an exception) we have not found comprehensive data to use for an impact assessment, although scattered pieces of information (usually deriving from product LCA's, e.g. of insulation materials) do exist. It has therefore not been possible to give a full LCA treatment of this part of the Danish energy system.

### **Greenhouse warming externalities of fossil fuel combustion**

The translation of the 10<sup>15</sup> US\$ impact from greenhouse emissions into externalities for specific energy activities may be done in the following way: It is assumed that about 75% of the forcing comes from energy-related emissions, and of these 17.5% are from natural gas, 40% from coal and 42.5% from oil. Present power stations typically emit 0.27 kgC/kWh<sub>elec</sub> if



coal-fired, 0.16 kgC/kWh<sub>elec</sub> if gas-fired and 0.21 kgC/kWh<sub>elec</sub> if oil-fired. The transportation sector mainly uses oil products and is responsible for 19.4% of the energy-related carbon emissions or 1.12 TkgC/y, which for gasoline driven automobiles corresponds to 659 gC/liter or about 49 gC per vehicle-km at an average of 13.5 km per litre of gasoline. The doubling of atmospheric greenhouse gases is now assumed to be due to 50 year's of emission at an average level 50% above the present one (corresponding to a doubling of fuel usage during the period). Using this assumption to distribute the total greenhouse externality cost on the carbon emissions over the next 50 years, one obtains a cost of 1.7 US\$/kgC or 0.46 US\$/kgCO<sub>2</sub>. This method of assigning all the impacts to future emissions is usually called the "grandfathering" approach. It addresses the costs of not acting now or in the future, rather than trying to determine who was responsible in the past.

According to the IPCC business-as-usual scenario IS92a, the additional greenhouse forcing associated with the business-as-usual scenario will be 2.3 W/m<sup>2</sup> by year 2050 as compared with around 2.5 W/m<sup>2</sup> from year 1765 to 1990 (IPCC I, 1995, p. 320-321). This is more than the 4 W/m<sup>2</sup> estimated to cause a doubling. Yet the IPCC working group II did estimate the impacts given in Table 10 under the assumption that IS92a would lead to a doubling of CO<sub>2</sub> sometime near the middle of the 21<sup>st</sup> century. This is still within the uncertainty of 0.5 W/m<sup>2</sup> estimated for the total radiative forcing from greenhouse gas emissions. If one considers that about half the forcing needed for the impacts considered has already been committed, then dispensing of the grandfathering principle and distributing the externality costs on all emissions since year 1765 would lead to half the cost figures quoted above. We mention this as a component in the discussion of distributing costs between early industrialised countries and developing nations, but shall in the following use the costs derived using the grandfathering principle.

Using 0.46 US\$/CO<sub>2</sub> or about 0.38 ECU/kgCO<sub>2</sub>, the greenhouse warming externality costs for coal-fired power stations become 0.40 US\$/kWh<sub>elec</sub> (0.31 ECU/kWh<sub>elec</sub>) and for gasoline-driven cars 0.072 US\$/vehicle-km (0.056 ECU/vehicle-km).

For biofuels, like biogas or methanol from biomass we do not count the CO<sub>2</sub> emissions, but the emissions of other greenhouse gases like N<sub>2</sub>O or CH<sub>4</sub> have been included in the data that we have used in the TEMIS calculations.

### **International ship and air transport**

Especially the fair market scenario has a considerable amount of international ship and air transportation, and we do include the greenhouse gas emissions associated with such activities. However, we do not include other emissions, as they occur outside Denmark, and for sea transport in maritime environments, for which we have not been able to find literature quantifying damage. In the sustainable scenario, only the use of energy within Denmark has been considered, and although international transport of goods and persons presumably do take place, this is not included in the scenario model.

### **LCA impacts of passenger transportation by road**

While impacts associated with electric vehicles have already been taken into account in connection with the electricity production, most of the impacts associated with fuel based vehicles (using fossil or bio-fuels) occur during use of the vehicle. In addition to the fuel-related impacts, the transport sector gives rise to a number of other externalities, that have recently been reviewed (Sørensen, 1996a), as regards the present situation. Table 13 and

Table 13. Impact from average Danish passenger car (1990).

Environmental impacts	type of impact: emissions (g per kWh of fuel)	monetised value (mECU per vehicle-km)	monetised value (mECU per kWh of fuel)	uncer- tainty & ranges
<i>Environmental emissions:</i>				
Car manufacture and decommissioning	average industry	15	23	H
Car maintenance	NQ			
Road construction and maintenance	NQ			
Operation:				
CO <sub>2</sub>	277			L
NO <sub>x</sub> (may form aerosols)	2.9			M
CO	17			M
HC	3.0			M
particles	0.06			M
Health effects from air pollutants		32	49	H,l,n
Greenhouse warming (cf. Table 9.3)	mainly from CO <sub>2</sub>	56	85	H,g,m
Noise	av. increase 1.5 dB, variations are large	25	38	H,l,n
Environmental & visual degradation (from roads, signs, filling stations, etc.)		107	162	H,l,m
<b>Health and injury</b>				
Occupational (car/road construction and maintenance)	cases: NQ			
Traffic accidents (incl. material damage, hospital and rescue costs): Based on deaths (SVL=2.6 Mecu) heavy injury light injury (when reported)	2.4x10 <sup>-8</sup> per kWh-fuel 24x10 <sup>-8</sup> per kWh-fuel 16x10 <sup>-8</sup> per kWh-fuel	83	125	M,l,n
Stress and inconvenience (e.g. to pedestrian passage)		26	39	H,l,n
<b>Economic impacts</b>				
Direct economy (cars, roads, gasoline, service and maintenance)	taxes excluded	215	327	L,l,n
Resource use	significant		NQ	
Labour requirements and import fraction (Denmark)	about 50% of direct costs are local		NQ	
Benefits (valued at cost of public transportation)		278	422	M,l,n
Time use (contingency valuation)		121	184	H,l,n
<b>Other impacts</b>	NA			

Sources: Danish Technology Council (1993), Danish Road Directorate (1981), Danish Statistical Office (1993), Danish Department of Public Works (1987), Christensen and Gudmundsen (1993), and own estimates. NA= not analysed, NQ= not quantified. Values are aggregated and rounded (to zero if below 0.1 mUS\$/kWh). (L,M,H): low, medium and high uncertainty. (l,r,g): local, regional and global impact. (n,m,d): near, medium and distant time frame.

Figure 25 summarise these findings, that use a value for the SVL of US\$ 3 million, close to the 2.6 MECU used in the ExternE study and here (1 ECU currently equals 1.20 US\$). Details of the assumptions are as follows:

The evaluation uses an average-size car, assumed to drive 200000 km in 10 years with an average efficiency of 13.5 km per liter of gasoline (corresponding to mixed urban and highway driving). The greenhouse warming externality of 7.2 US\$/km comes from the evaluation made

above. The health effect caused by air pollution from car exhaust is taken as 4.1 US\$/km, a number arrived at in several of the Scandinavian studies quoted below Table 13. Also the accident statistics gives a firm basis for estimation (although the rate of accidents varies considerably between countries - the value used here corresponds to Denmark), but the value of police and rescue team efforts, hospital treatment, lost workdays and lives all have to be chosen. As mentioned above, the SVL underlying Table 13 was assumed to be 3 M\$, and for time loss a figure of 9.4 \$/h is used (based on an interview study on perceived values of waiting time; Danish Technology Council, 1993). This is a "recreational" value in the sense that it rather corresponds to unemployment compensation than to average salary. The "stress and inconvenience" line takes into account the barrier effect of roads with traffic, causing e.g. pedestrians to have to wait (e.g. at red lights) or to walk a larger distance to circumvent the road barrier. This may again be valued as time lost.

The noise impact is estimated at 3.2 US\$/km based on hedonic pricing (i.e. the reduction in the value of property exposed to noise (e.g. houses along major highways as compared to those in secluded suburban locations) (Danish Transport Council, 1993). A similar approach is taken to estimate the visual degradation of the environment due to roads, signs, filling stations, parking lots and so on. Property values have been collected in 1996 (from newspaper advertisements), for detached houses of similar standard, located at the same distances from the Copenhagen city centre (but outside the high rise area, at distances of 10 to 25 km from the centre), but exposed to different levels of visual and noise impact from traffic. The externality is then taken as the number of people exposed times the sum of property losses. The property loss found is 25-45%, and the total damage for 0.5 million people with 0.2 million houses and cars is 20.5 G\$ or 54 US\$/km, of which half is assumed to derive from visual impacts. A further reduction by a factor two is introduced by going from a suburban environment near Copenhagen to a country average<sup>0</sup>. The value arrived at (for Denmark) is the 13.8 US\$/km given in Table 13.

The direct economic impacts include capital expenses and operation for cars and roads, as well as property value of parking space in garages, carports or open parking space, but omitting any taxes and duties, and the benefits from driving are taken at the value of public transport (considering that differences in convenience and inconveniences such as not being able to read when driving even out). Time use is as mentioned above derived from a contingency valuation (i.e. interviews). The "fairly calculated" cost of driving a passenger car, i.e. all direct costs and indirect LCA impact items except benefits and time use, add up to 0.65 US\$/km, of which 0.07 are related to owning the car (purchase price without taxes plus environmental impacts of car manufacture), and the remaining 0.58 US\$/km are related to driving the car. A fair tax level, reflecting external costs, would then be divided into a vehicle tax of around 4100 US\$, and a kilometers-driven component, that levied onto the fuel would amount to about 5 US\$ per litre. Figure 25 shows this division between ownership and usage impacts, and compares the "fair" taxation with the current Danish tax levels for car ownership and gasoline purchase.

In line with this study of current LCA impacts of passenger transportation and car ownership, the following impacts have been included in the present analysis of the current and the two future energy systems:

- health effects from pollutants
- traffic accidents
- contributions to enhance the greenhouse effect

- noise
- visual aspects
- barrier effects and inconvenience from road installations
- road construction
- car manufacture and decommissioning

The energy efficiency in the transport sector has been assumed to increase by a factor of three in the environmentally sustainable scenario and by a factor of four in the fair market scenario. This means that impacts proportional to the number of kilometres driven appear correspondingly larger when expressed per unit of fuel energy. This will apply to almost all impacts, save the public health impacts that stem from emissions of SO<sub>2</sub>, NO<sub>x</sub>, and particles. For these impact we assume that emissions will stay about the same as today, which may be conservative assumption. Our reason for this assumptions is, that although SO<sub>2</sub> emissions are likely to go down, this may not be the case for particles and NO<sub>x</sub>, derived from biomass in the future scenarios. Table 14 shows the assumed social costs, for the current Danish system and the two future scenarios. As the environmentally sustainable scenario (ESS) has no use of fossil fuels, the greenhouse impacts are zero except for car-related goods that are imported. For the fair market scenario (FMS), fossil fuels are only used in ship and air traffic, so the same applies here. The cost of road construction and maintenance is taken as an externality, in line with the reference given. This assumes that roads are only needed for automobile traffic, which may be only partially true (although the infrastructure solutions would certainly be different if other modes of transportation were introduced).

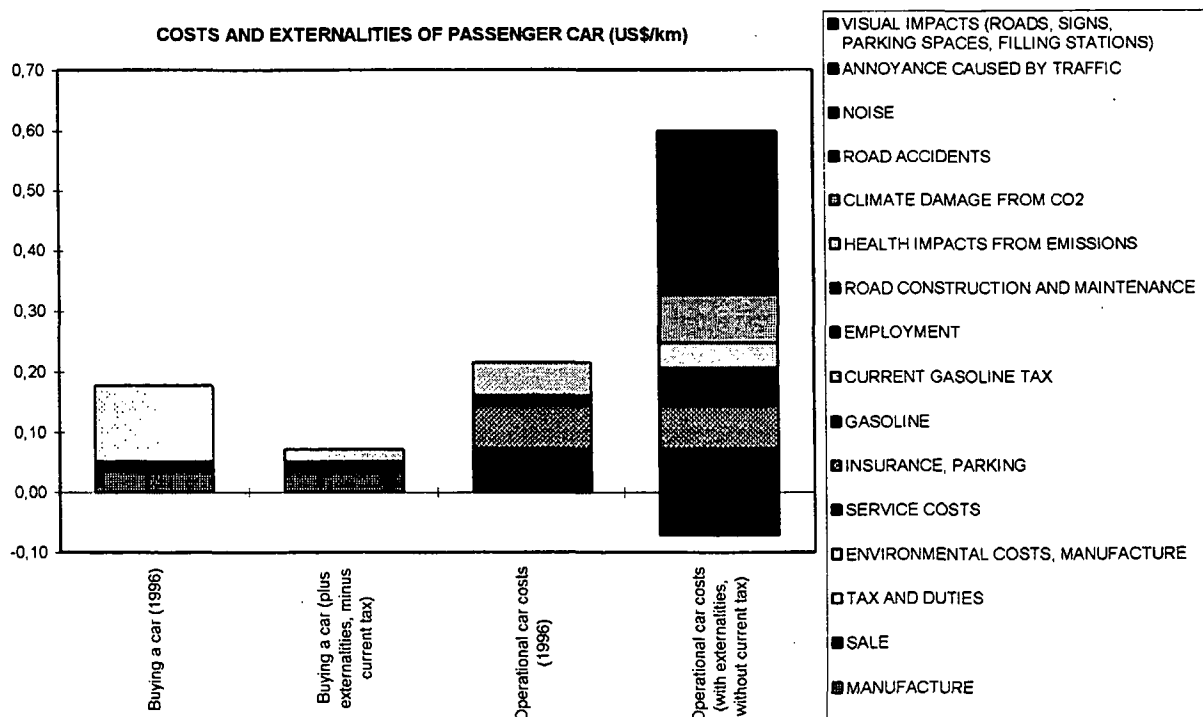

Figure 25. Components of costs and externalities for privately owned motor car (1 US\$=0.83 ECU).

**Table 14. Monetised social costs of passenger transport by road (ECU/MWh<sub>fuel</sub> or elec. from renewables)**

	Current	ESS	FMS
	ECU <sub>1990</sub> /MWh		
car manufacture	22,0	75,7	97,0
road construction	32,5	111,7	143,2
traffic accidents*	126,4	435,2	557,8
noise	38,5	132,4	169,8
envir. & visual impacts	163,3	562,2	720,6
emission impacts on public health	44,0	21,9	20,7
greenhouse warming impacts	85,6	27,6	37,8
barriere effects	39,3	135,2	173,2
<b>total</b>	<b>551,6</b>	<b>1.501,9</b>	<b>1.920,1</b>
rel. energy use (domestic transport)	1,00	0,19	0,34
rel. intensity of passenger transport	1,00	0,65	1,50

Source: Danish Transport Council (1993) for road construction; Sørensen (1996a) for other present data, with adjustments for the future scenarios ESS (environmentally sustainable) and FMS (fair market). Greenhouse warming impacts for the future scenarios make conservative assumptions on transport of biomass to fuel-production plants and on releases of e.g. methane in those plants.

\* The figures on traffic accidents are recalculated from the Danish investigation quoted, using now the SVL of 2.6 MECU.

We have not taken into account the direct impacts of public transportation. Presently, these impacts are small compared to those of private road transport. The impacts from freight transport sector are included in the overview of the total energy system, for example transportation of liquid manure for biogas installations.

Contrary to power generation the global impacts from greenhouse gases are evidently not the most important ones but rather the impacts on the visual environment and accidents.

### Summary of impact areas covered

Table 15 indicates the areas where we have been able to find emission data for the current system, in the energy statistics and background reports to the Energy 21 planning work of the Danish Energy Agency, in reports from the Danish Transport Council, and the extent to which we have felt confident about monetising the corresponding impacts.

**Table 15. Data availability for the present Danish energy system**

Sector / Emission	Power stations	District heating	Industry	Passenger transportation	Domestic & service sectors
Greenhouse gases	yes	yes	yes	yes	yes
SO <sub>2</sub>	yes	yes	yes	yes	-
NO <sub>x</sub>	yes	yes	yes	yes	-
particles	yes	yes	yes	yes	-
land use	yes	yes	yes	-	-

Notes: "-" means no data on damage response functions available.

Lack of adequate data occurs in several end-use applications, where we have only sporadic data, e.g. for impacts from producing insulation material for district heating lines and buildings and for emissions from passenger cars. The transfer of power plant impacts to industrial and domestic boilers is considered a fair approximation for the current energy system, provided that impacts are calculated per unit of emission, but for future energy system components, such as fuel cells, only gross estimates are available. Generally decentralisation of energy conversion processes will lead to lower emission heights and for that reason likely larger specific impacts.

**Table 16. Data availability for the future Danish energy systems.**

Sector / Emission	Power generation	District heating	Industry	Private Transport	Households & Service Sectors
GHE	yes	yes	yes	yes	yes
SO <sub>2</sub>	some uncertainty	some uncertainty	some uncertainty	yes	-
NO <sub>x</sub>	some uncertainty	some uncertainty	some uncertainty	yes	-
particles	some uncertainty	some uncertainty	some uncertainty	yes	-
land use	some uncertainty	some uncertainty	some uncertainty	-	-

Notes: "-" means no data on damage response functions available.

Table 16 gives our views concerning the solidity of data used for the future scenarios. As we have had to extrapolate knowledge on production techniques we estimate that particularly for the emerging technologies assumed in the scenarios, the change predicted for the impact changes relative to current technology has some element of uncertainty. On the other hand, it would of course have been more unrealistic, if we had assumed no improvements over a period of 30-50 years. The scenarios represent an attempt to distinguish between a large number of optional technologies emerging on the horizon today, using as guidelines the observed trends in attitudes and preferences within at least the Danish population. No excuse is made for not foreseeing the advent of entirely new technologies appearing and coming to dominate the market. We shall simply assume that if such technologies do energy (as history indicates that they certainly will!), then they will be more benign than the ones we have assumed, because if not, they would not be consistent with the value basis of our future society. What can and should be discussed, of course, is the validity appropriateness of our analysis of the trends in value shifts.

#### 4.5 Chain analysis of selected energy supply options

Although we are going to use of LCA and externality data on total energy systems according to the scheme called "B" in Chapter 2, it is useful to look at the simple chain calculations going through the cradle to grave impacts of a given technology (called "A" in Chapter 2), because this allows us to compare our calculations with earlier studies of this type, such as ExternE, and exhibit the differences found.

Tables 17-21 gives LCA impacts for the coal power, wind power, photovoltaic power, biogas and methanol energy chains according to our data selection, and Tables 22-25 gives the corresponding results from the ExternE project for coal and natural gas based power, wind power, and from an earlier study of photovoltaic power, with more details than the summary in Table 11 (Sørensen, 1995d). The steps included in the coal, gas and photovoltaics energy chains are indicated in Figures 26-28.

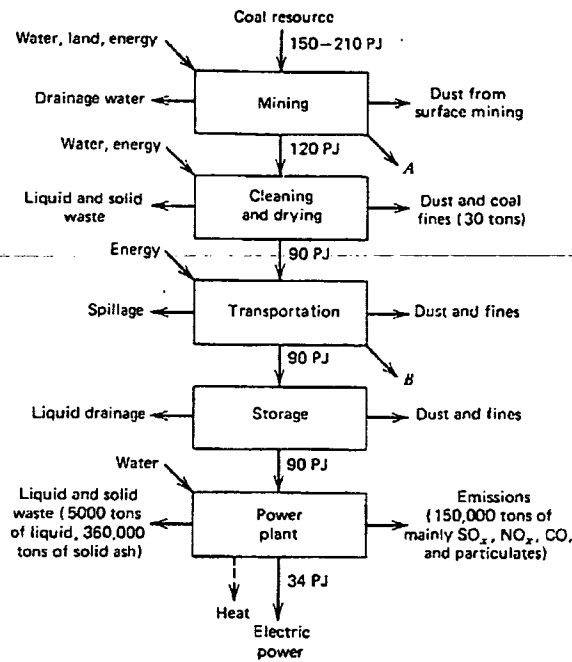

Figure 26. Coal-based electricity chain (Sørensen, 1993).

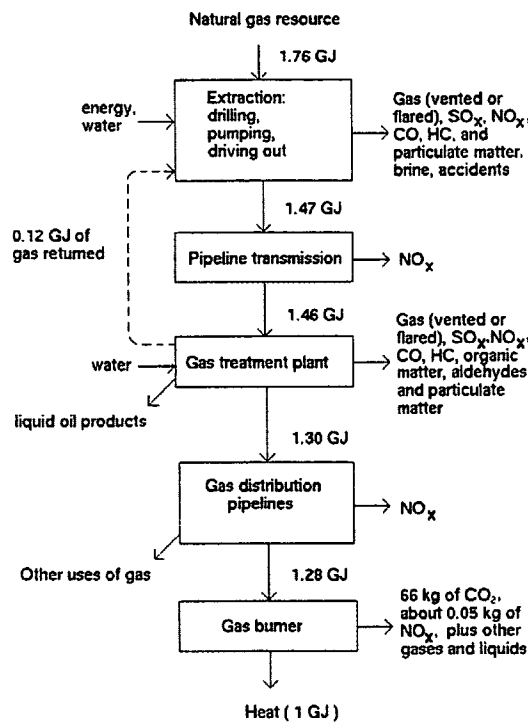

Figure 27. Natural gas based domestic heating chain (Sørensen, 1993).

The numbers in Table 17 differ somewhat from the ExternE figures given in Table 22. For air pollution the impacts are as mentioned earlier different due to both emission differences and particularly differences in population densities in typical stack wake areas for Denmark and

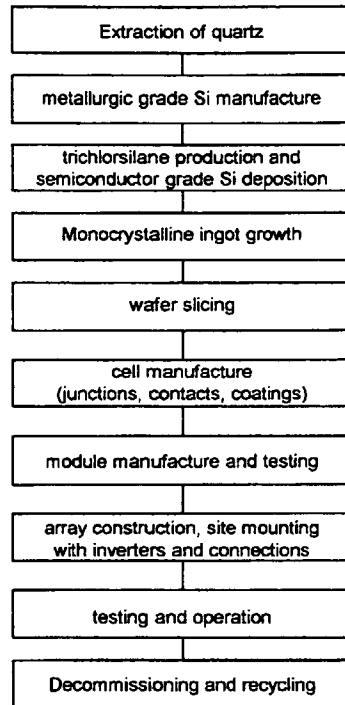

Figure 28. Photovoltaic power chain (Sørensen, 1995d)

central Germany. The higher greenhouse gas externality is due to the lower efficiency of electricity production at the Danish CHP plant as compared with a pure electricity producing plant. It will have to be distributed on electricity and heat users, and a "fair" distribution will lead to a lower Danish electricity impact than the German one.

For wind power the emissions given in Table 18a are basically from turbine manufacture and for the future column assumes a mix of 1 MW turbines on land and 3 MW turbines off-shore. The concrete content is larger for off-shore turbines (foundations), leading to the larger industrial particle emissions. The occupational health data used in Table 18a are from the ExternE study and very much reflect the road accidents associated with construction and maintenance crews travelling to and from the turbines. We think the number of visits for maintenance is exaggerated compared to Danish experience, and Table 24 reflects the estimated Danish amount of transport work (industry interviews). Also the visual impact valuation given in Table 18a is an average of ExternE estimations for British wind farms, very much influenced by a single wind farm (Delabole) located near a national park. Table 24 reflects the value for the other, more suitable sited parks.

Several alternative calculations of life-cycle impacts from wind turbines were presented at the recent European Wind Energy Conference (Wiese and Kaltschmitt, 1996; Hinch, 1996; Kehrbaum, 1996), the two latter studies with particular emphasis on the impacts from decommissioning and possibly recycling wind turbines. The emissions and energy pay-back times found are very similar to ours, as seen from Table 18b. The decommissioning emissions are found to be about three orders of magnitude lower than those arising during manufacture and operation/maintenance.



Table 17. Full chain analysis of Danish coal power station.

Coal power plant			
	current	future	
	impact	impact	current future monetised value
			(mECU/kWh-elec.)
	(g/kWh-elec.)		
SO <sub>2</sub>	1,21		2,76
NO <sub>x</sub>	1,26		2,89
Particles	0,30		0,69
CO <sub>2</sub>	1104		414,0
CO <sub>2</sub> equivalent	1183		443,6
	(months)		
Energy payback time	3,5		
<b>Occupational Health Impacts from manufacture and O&amp;M</b>			
	(cases per kWh elec.)		
Deaths	2,8E-10		0,73
Major injuries	6,9E-09		0,54
Minor injuries	5,1E-08		0,061
Work hours lost	??		??
Years of life lost	6,8E-09		17,7
	(g/kWh-elec.)		
groundwater used	2129		
open mining residue heaps	3193		
flue-gas desulph. residues	16		
Power plant ashes/residues	121		

The emissions are based on Fynsværket (ELSAM, 1996). Both impacts and monetised values are given per kWh of electricity produced, although a distribution on heat and power would be needed in a sectorial distribution of social costs. The basis for evaluating occupational and other impacts is given in Appendix A.

The photovoltaics industry emission data used in Table 19 are from Phylipsen and Alsema (1995) and pertain to multicrystalline silicon based systems. The "future" column represent their "best case", which is very similar to the future case of Table 25, based on Australian and Japanese work. For the current situation, Table 25 uses a state-of-the-art manufacturing plant (with reference to the BP-solar plant near Madrid, cf. Sørensen and Watt, 1993), while the Dutch study uses a more conventional plant built some years ago, which is also seen by the 30 year energy payback time estimated. The large occupational impact comes from providing this energy, assumed to be coal. Another difference is that Table 25 is for a southern European location, whereas Table 19 assumes the production expected at a Danish location. Because the same panel will produce considerably less energy over the year in Denmark, the per kWh impacts are correspondingly greater. The "future" energy payback time of 8 years found in the Dutch study is for a multicrystalline technology emerging from the one used today. The alternative values of 3 years today and 6 months by year 2010 given in Table 25 pertain to amorphous silicon technologies, and are estimated by Yamada et al. (1995). There is clearly considerable uncertainty regarding the characteristics of future PV technology.

**Table 18a. Full chain analysis of present and future wind power facilities.**

<b>wind</b>				
	current impact	future	current	future
			monetised value	
			(mECU/kWh)	
	(g/kWh)			
SO <sub>2</sub>	0,02	0,00	0,05	0,00
NO <sub>x</sub>	0,03	0,02	0,10	0,07
Particles	0,00	0,01	0,02	0,03
CO <sub>2</sub>	11	5	4,0	1,7
CO <sub>2</sub> equivalent	12	5	4,6	1,9
	(months)			
Energy payback time	9,9	7,7		
<b>Occupational Health Impacts from manufacture and O&amp;M</b>				
	(cases per kWh)			
Deaths	3,6E-11		0,09	
Major injuries	4,0E-09		0,31	
Minor injuries	8,7E-09		0,01	
Work hours lost	??		??	
Years of life lost	9,8E-11		0,25	
Visual Intrusion			0,59	
Noise			0,10	

Emission data from TEMIS (1993), occupational and other impacts from European Commission (1996f), cf. Appendix A.

**Table 18b. German study of wind power life-cycle impacts, for three different wind regimes (Wiese and Kaltschmitt, 1996).**

	4.5 m/s <sup>4</sup>	5.5 m/s <sup>4</sup>	6.5 m/s <sup>4</sup>
<b>material balances<sup>1</sup></b>			
steel in kg/GWh	2,740 - 3,710	1,880 - 2,360	1,450 - 1,890
non-ferrous-metals in kg/GWh <sup>2</sup>	90 - 140	60 - 90	50 - 70
cement in kg/GWh	1,610 - 3,460	1,100 - 2,200	850 - 1,760
plastics in kg/GWh	340 - 610	230 - 390	180 - 310
<b>energy balances</b>			
KEA <sub>prim</sub> <sup>3</sup> in kWh <sub>prim</sub> /MWh <sup>1</sup>	70 - 230	50 - 150	35 - 120
energy harvest factor	44 - 12	64 - 19	82 - 24
energy amortisation time in months	6 - 20	4 - 13	2 - 8
<b>emission balances<sup>1</sup></b>			
SO <sub>2</sub> in kg/GWh	18 - 32	13 - 20	10 - 16
NO <sub>x</sub> in kg/GWh	26 - 43	18 - 27	14 - 22
CO <sub>2</sub> in t/GWh	19 - 34	13 - 22	10 - 17

<sup>1</sup> Related to the entire electrical energy produced during the lifetime of the wind converter; <sup>2</sup> Copper; <sup>3</sup> Cumulated energy consumption; <sup>4</sup> Annual mean wind velocity in 10 m above ground.

Table 19. Full chain analysis of photovoltaic power systems.

<b>PV</b>				
	current future impact		current future monetised value	
	(g/kWh)		(mECU/kWh)	
SO <sub>2</sub>	0,30	0,01	0,68	0,03
NO <sub>x</sub>	0,40	0,09	1,28	0,30
Particles	0,06	0,01	0,22	0,04
CO <sub>2</sub>	258	3	96,7	1,1
CO <sub>2</sub> equivalent	286	9	107,2	3,5
(months)				
Energy payback time	365,0	85,0		
<b>Occupational Health Impacts from manufacture and O&amp;M</b>				
(cases per kWh)				
Deaths	7,1E-11		0,19	
Major injuries	1,6E-09		0,13	
Minor injuries	6,4E-09		0,008	
Work hours lost	1,5E-06		??	
Years of life lost	2,3E-08		59,6	

Based on Philipsen and Alsema (1995), cf. Appendix A.

Table 20. Full chain analysis of biogas plant.

<b>biogas</b>				
	current future impact		current future monetised value	
	(g/kWh)		(mECU/kWh)	
SO <sub>2</sub>	0,25	0,01	0,58	0,02
NO <sub>x</sub>	0,36	0,06	1,15	0,19
Particles	0,03	0,00	0,10	0,00
CO <sub>2</sub>	61	0	22,8	0,1
CO <sub>2</sub> equivalent	74	54	27,9	20,2
(months)				
Energy payback time	25,0	6,9		
<b>Occupational Health Impacts from manufacture and O&amp;M</b>				
(cases per kWh)				
Deaths	1,7E-09		4,42	
Major injuries	2,2E-09		0,17	
Minor injuries	7,0E-08		0,083	
Work hours lost	??		??	
Years of life lost	6,0E-09		15,6	

Based on TEMIS (1993), cf. Appendix A. Most of the occupational impacts come from transport of biomass.

The biogas chain impacts shown in Table 20 are estimated on the basis of emissions and energy production for the Ribe plant (Danish Energy Agency, 1996a) for the current technology. The future technology differs primarily by the type of energy used in manufacture and for transport of biomass. The fact that greenhouse externalities remain about the same is that they mostly derive from heat use within the plant - using some of the biogas produced - and also methane escaping to the environment. Methane emissions from the cattle itself are not counted, as they are considered to be the same as without the diversion of manure to the biogas plants.

**Table 21. Full chain analysis of methanol plant, based on woody biomass.**

<b>methanol</b>				
	current	future	current	future
	impact		monetised value	
			(mECU/kWh)	
	(g/kWh)			
SO <sub>2</sub>	0,22	0,07	0,50	0,16
NO <sub>x</sub>	1,39	0,22	4,41	0,69
Particles	0,10	0,00	0,38	0,02
CO <sub>2</sub>	109	1	41,0	0,6
CO <sub>2</sub> equivalent	214	69	80,3	25,9
	(months)			
Energy payback time	50,8	24,7		
<b>Occupational Health Impacts from manufacture and O&amp;M</b>				
	(cases per kWh)			
Deaths	3,1E-09		7,94	
Major injuries	1,5E-08		1,19	
Minor injuries	3,6E-08		0,043	
Work hours lost	??		??	
Years of life lost	2,2E-09		5,7	
Area Use	0,4	m <sup>2</sup> /kWh		
	(g/kWh)			
Biocides application	40			
Fertiliser application	2038			

See Appendix A for assumptions for bio-plantations and gasification. Forestry impacts are from Meyer et al. (1994). Occupational impacts are mostly from forestry and transport of woodfuel to the gasification plant.

The methanol chain impacts shown in Table 21 are uncertain because no large-scale production takes place today. The emissions are based upon high-temperature gasification using as fuel wood or some of the gas produced (Jensen and Sørensen, 1984; European Commission, 1994). Occupational impacts are mostly from transportation of biomass, assumed to involve longer distances than the transport of material for biogas plants, because methanol production is a large-scale industrial process taking place in centralised plants similar to refineries. The other impacts are related to energy plantations and are taken from Meyer et al. (1994). For the future situation, we have not found any useful data, but would assume that less biocides and fertiliser is applied, in something like what is called "integrated agriculture" (Danish Technology Council, 1994).

**Table 22. Impacts from coal fuel chain (state-of-the-art technology, power station location: West Burton, UK, European Commission, 1995c; greenhouse warming impacts, economic and other impacts from Sørensen, 1996c)**

Environmental impacts	type of impact: emissions (g/kWh)	uncertainty	monetised value mECU/kWh	uncertainty & ranges*
1. Plant construction/decommissioning	NA		NA	
2. Plant operation		L		
CO <sub>2</sub>	880	M		
SO <sub>2</sub> (may form aerosols)	1.1	M		
NO <sub>x</sub> (may form aerosols)	2.2	M		
particulates	0.16	M		
CH <sub>4</sub>	3	H		
N <sub>2</sub> O	0.5			
Greenhouse warming (cf. Table 10)	from CO <sub>2</sub> , CH <sub>4</sub> ,...		310	H,g,m
Degradation of building materials	from acid rain		0.8	H,r,n
Reduced crop yields	from acid rain		NQ	
Forest and ecosystem impacts			NQ	
Ozone impacts			NQ	
	cases:	H		
Mortality from particles (PM <sub>10</sub> )	1 per TWh		2.7	H,r,n
from aerosols	0.2 per TWh		0.5	H,r,n
from chronic effects	7 per Twh		NQ	
Morbidity from dust and aerosols,				
major acute	0.4 per Twh		0	M,r,n
minor acute	40000 work days lost/TWh		0.6	M,r,n
chronic cases	150 per TWh		0	M,r,m
Noise (from power plant)			0.1	M,l,n
Occupational health and injury				
1. Mining diseases			0.1	M,l,m
Mining accidents, death	0.1 per TWh		0.2	L,l,n
major injury	3.1 per TWh		0.4	L,l,n
minor injury	27 per TWh		0.1	H,l,n
2. Transport, death	0.02 per Twh		0.1	L,l,n
major injury	0.15 per Twh		0	M,l,n
minor injury	0.69 per TWh		0	H,l,n
3. Construction/decommissioning	0 per TWh		0	M,l,n
4. Operation	0 per TWh		0	L,l,n
Economic impacts				
Direct economy			25-45	
Resource use	low but finite		NQ	
Labour requirements			NQ	
Import fraction (UK plant)	local coal assumed		NQ	
Benefits from power			50-150	
Other impacts				
Supply security	many import options		NQ	
Robustness (against technical error, planning errors, assessment changes)	fairly low for large plants		NQ	
Global issues	competition		NQ	
Decentralisation and consumer choice	not possible		NQ	
Institution building	modest		NQ	

NA= not analysed, NQ= not quantified. Values are aggregated and rounded (to zero if below 0.1 mECU/kWh).

\* (L,M,H): low, medium and high uncertainty. (l,r,g): local, regional and global impact. (n,m,d): near, medium and distant time frame.

**Table 23. Impacts from new natural gas fired power chain (power station location: West Burton, UK, European Commission, 1995d; greenhouse warming impacts, economic and other impacts from Sørensen, 1996c)**

Enviromental impacts	type of impact: emissions (g/kWh)	uncer- tainty	monetised value mECU/kWh	uncer- tainty & ranges*
Main emissions:		L		
CO <sub>2</sub>	520	M		
NO <sub>x</sub> (may form aerosols)	0.71	M		
CH <sub>4</sub>	0.28	M		
N <sub>2</sub> O	0.014			
Greenhouse warming (cf. Table 10)	from CO <sub>2</sub> ,CH <sub>4</sub> ,...	M	190	H,g,m
Degradation of steel, painted surfaces	from acid rain		0.11	H,r,n
Mortality from acid aerosols	cases: 0.16 per TWh	M	0.43	M,r,n
Morbidity from acid aerosols	6200 symptom days, 520 with problems, per TWh	M	0.08	H,r,n
Noise (from power station)	regulatory maximum		0.03	M,l,n
<b>Occupational health and injury</b>				
Accidents:				
Major off-shore platform accidents	0.016 per TWh		0.04	H,l,n
Other off-shore platform accidents	0.005 per TWh		0.01	H,l,n
Injury:				
Off-shore platform construction	0.07 per Twh		0.01	H,l,n
<b>Economic impacts</b>				
Direct economy			40-50	
Resource use	low but finite		NQ	
Labour requirements			NQ	
Import fraction (UK plant)	British gas assumed		NQ	
Benefits from power			50-150	
<b>Other impacts</b>				
Supply security	depends on pipeline integrity		NQ	
Robustness (against technical error, planning errors, assessment changes)	fairly low for large plants		NQ	
Global issues	competition		NQ	
Decentralisation and consumer choice	not possible		NQ	
Institution building	modest		NQ	

NA= not analysed, NQ= not quantified. Other impacts were estimated but found below 0.01 mECU/kWh. See notes to Figure 22.

**Table 24. Impacts from wind energy systems (locations: Typical Danish land site , Meyer et al., 1994; Penrhyddlan/Llidiartywaun, UK, European Commission, 1995f; greenhouse warming impacts, economic and other impacts from Sørensen, 1996c)**

<b>Environmental impacts</b>	<b>impact type: emissions (g/kWh)</b>	<b>un- cer- tainty</b>	<b>monetised value mECU/kWh</b>	<b>uncer- tainty &amp; ranges</b>
<b>Releases from fossil energy used:</b>				
1. Turbine manufacture (6.6 GJ/kW rated)				
CO <sub>2</sub> (leading to greenhouse effect)	12.1	L	4.3	H,g,m
SO <sub>2</sub> (leading to acid rain and aerosols)	0.05	L	0.1	H,r,n
NO <sub>x</sub> (possibly aerosols and health impacts)	0.04	L	0	H,r,n
particulates (lung diseases)	0.002	L	0.1	H,r,n
2. Operation (2.2 GJ/kW over 20 year lifetime)				
CO <sub>2</sub> (leading to greenhouse effect)	3.8	L	1.3	H,g,m
SO <sub>2</sub> (leading to acid rain and aerosols)	0.01	L	0	
NO <sub>x</sub> (possibly aerosols and health impacts)	0.02	L	0	
particulates (lung diseases)	0	L	0	
other:				
Noise from gearbox at inhabited areas	<1 dB(A)		0.1	H,l,n
from wind-blade interaction	<3 dB(A)		total	
Land use	10m <sup>2</sup> /kW		NQ	
<b>Social impacts</b>				
Occupational injuries (manuf. & materials):				
1. Turbine manufacture, death				
major injury	0.03/Twh	L	0	L,l,n
minor injury	0.9/TWh	L	0.1	L,l,n
	5/TWh	M	0	M,l,n
2. Operation (same categories combined)				
			0	M,l,n
<b>Economic impacts</b>				
Direct costs				
Ressource use (energy payback time given)	1.1 y	L	40-90	
Labour requirements (manufacture)	9man y/MW	L	NQ	
Import fraction (for Denmark)	0.28	L	NQ	
Benefits from power sold (penetration < 30%)			40-120	
<b>Other impacts</b>				
Supply security (variability in wind is high, entry based on plant availability)	high		NQ	
Robustness (up-front investment binds, entry based on technical reliability)	high		NQ	
Global issues (non-exploiting)	compatible		NQ	
Decentralisation & choice (less with large size)	good		NQ	
Institution building (grid required)	modest		NQ	

See notes to Table 22.

**Table 25. Impacts from rooftop photovoltaic energy systems based on polycrystalline (p-Si) or amorphous (a-Si) Silicon cells, placed at average European locations (Sørensen, 1996c and references quoted below).**

Environmental impacts	impact type: emissions (g/kWh)	uncertainty	monetised value mECU/kWh	uncertainty & ranges
Releases from fossil energy if used in the steps of the PV conversion cycle:				
CO <sub>2</sub> (p-Si now and around 2010)	75, 30	L		H,g,m
(a-Si now and around 2010)	44, 11	L		H,r,n
SO <sub>2</sub> and NO <sub>x</sub> (p-Si now and around 2010)	0.3, 0.1	L		H,r,n
(a-Si now and around 2010)	0.2, <b>0.04</b>	L		H,r,n
Greenhouse effect from fossil emissions (p-Si)			26, 11	H,g,m
(a-Si, both either now or in 2010)			16, <b>3.8</b>	H,g,m
(if PV production energy use around 2010 is primarily from non-fossil sources)			<b>0</b>	
Mortality and morbidity from fossil air pollution described above (p-Si, now and 2010)			0.4, 0.1	H,r,n
(a-Si, now and 2010)			0.2, <b>0</b>	H,r,n
Land use	<b>0</b>		<b>0</b>	L,l,n
Visual intrusion			NQ	
<b>Social impacts</b>				
Occupational injuries:				
1. From fossil fuel use(p-Si now and 2010)			0.1, 0.03	L,l,n
(a-Si now and 2010)			0.05, <b>0.01</b>	L,l,n
2. From panel manufacture			NA	
3. From construction and decommissioning (differential from using other building materials)				
4. From operation			<b>0</b>	L,l,n
			<b>0</b>	L,l,n
<b>Economic impacts</b>				
Direct costs (at present)			300-600	
(around 2010)			<b>30-90</b>	H
Energy payback time (now and 2010, a-Si)	3y, 0.5y		NQ	
Labour requirements (now and 2010)	40, 4 man y/MW		NQ	
Benefits from power sold (penetration < 20%)			<b>40-120</b>	H
<b>Other impacts</b>				
Supply security (variability in solar radiation is high, entry based on plant availability)	high		NQ	
Robustness (up-front investment binds, entry based on technical reliability)	high		NQ	
Global issues (non-exploiting)	compatible		NQ	
Decentralisation & choice	good		NQ	
Institution building (grid required)	modest		NQ	

Based on Sørensen & Watt, 1993, Sørensen, 1994, Yamada et al. 1995. See also notes to Table 22. Solid figures assume that renewable energy is used in manufacture of solar cells.



## 5. MODEL RESULTS

In this chapter we present the overall results for the current (1992) Danish energy system and the two future scenarios, the ecologically sustainable scenario (ESS) for 2030 and the fair market scenario (FMS) for 2050. As discussed in Chapter 2 there are two alternative ways of treating import and export: either to include impacts from imported goods, e.g. energy, materials or equipment, and neglect impacts associated with goods to be exported ("product view") or vice versa ("economy view"). We shall label these two views with the endings "-P" and "-E". The Danish 1992 system had a little import of electricity from Norway and no export. The ESS does not assume any import or export of energy, whereas the FMS includes large amounts of wind-produced electricity and hydrogen exported to Germany. The way in which we have been able to explore the two views is to do the LCA calculations in two ways:

- include impacts along the entire chains of energy conversions, whether they occur in Denmark or abroad, usually called "full energy chain" or FENCH analysis (Dones *et al.*, 1994, Hirschberg *et al.*, 1994), we shall use the suffix "-F".
- only include impacts occurring as a result of activities within Denmark or from Danish off-shore activities (which we shall denote "domestic" analysis and describe by the suffix "-D").

The full energy chain analysis is equivalent to the product view, provided that energy and other goods produced for export are omitted from the impact analysis, and the domestic analysis is in principle identical to the economy view, but in our treatment not in practice, because we assume that all equipment and non-energy materials used in the Danish energy sector are imported (in this way, we avoid having to reduce industrial energy demand by what is used to service the energy industry, for reasons of not double counting - cf. chapter 2). It should be noted, that impacts from domestic activities may impact on foreign countries, e.g. through transboundary pollution transport or global dispersion of greenhouse gases.

Available data make it simple to exclude energy produced in Denmark for export from a P-type analysis, but we are unable to exclude the impacts from other products exported, since their production uses the Danish energy system (for which we include impacts) and statistical data does not allow the energy content of exported non-energy products to be determined in any simple way. This is the reason that do not do a P-type calculation, but replace it by the F-type full energy chain analysis. *The results of our F-type analysis will thus be an upper bound for the correct product view analysis.* It makes no difference that we have assumed equipment and non-energy materials for the energy sector to be imported, as their impacts should be, and are, included no matter whether produced in Denmark or abroad.

This is also the reason, why we have to make a distinction between the D-type analysis, which we are able to make, and the E-type calculation, which should have included the fraction of impacts from equipment and materials produced within Denmark for use in the energy sector. *The results of our D-type analysis will thus be a lower bound for the correct economy view analysis.* In this way we are able to state a set of lower and upper bounds for the LCA impacts of the energy system, that spans and perhaps exaggerate the difference between the two ways of accounting. If the two resulting values are not too far apart, we have done a good job at quantifying the life-cycle impacts and exhibiting their uncertainty. It should be noted, that with some additional work, the D-type analysis could be transformed into a proper E-type analysis, whereas the upgrading of an F-type calculation to a P-type would require collection of data not presently available.

Table 26 summarises what is included in the cases that we are going to present.

**Table 26. Characteristics of the cases considered.**

Acronym	energy produced for export included	energy import impacts considered
1992-F	no	yes
1992-D	yes	no
2030 ESS-F	no	yes
2030 ESS-D	yes	no
2050 FMS-F	no	yes
2050 FMS-D	yes	no

### 5.1 Overall results of LCA model calculations

We present the monetised value of all the impacts quantified in Table 27. As there are impacts not evaluated, we have not summed up the impacts to a total, but regard the monetised social costs as subtotals representing currently known costs. However, we have been able to estimate impacts for a number of areas presently identified and considered important, and so the externalities found do have a concrete role to play in energy policy debates.

Occupational health impacts from the energy sector are modest today and are not expected to increase, despite the introduction of new technologies associated with e.g. wind and biofuel use. Occupational hazards have been identified in connection with these new production technologies, but also ways of limiting the associated risks.

The public health costs are seen to be significant today, but playing a modest role for the future scenarios. The dominating social cost is due to greenhouse warming, and as we have seen most of the damage actually occurs far from Denmark, in developing nations closer to the Equator. The total greenhouse warming impacts of the future scenarios are estimated as 5-10% of the present impacts. The origin of these externalities is chiefly the production, transportation and combustion of biomass for the bio-energy sector, and they may well be reduced, if e.g. agricultural practices are altered in the direction of ecological agriculture, such as the suggested integrated agricultural production (Danish Technology Council, 1994). The emissions associated with conversion of biomass may theoretically become zero, and our estimates are based mainly on existing or short-term foreseeable practices (European Commission, 1994), which should be improved in a future society placing emphasis on greenhouse warming limitation. It is a clear political message, that large-scale reliance of biofuel technologies must be accompanied by very strict environmental control.

The transport sector is characterised by large impacts today, and the projection is that the future scenarios considered will not limit this externality cost, although it diminishes for the low traffic-intensity ecologically sustainable scenario and increases for the transport-intensive fair market scenario (where, additionally, we have not been able to include the impacts associated with steeply increasing international transport). Again, the policies and regulations applied to the development of domestic and international transport should be a policy item of dominating importance.

The uncertainty of both physical damage estimates and monetarisation is considerable. However, the nature of the uncertainty is different for the dominating greenhouse warming

impacts and the air pollution, work and traffic impacts. The uncertainty of the greenhouse warming externality is dominated by the political issue of whether or not to value lives in the Third World - where most of the damage occurs - similar to lives lost in our own society, whereas the valuation of other impacts is a matter for local or regional political debate. Table 28 gives uncertainty estimates for a few selected impact categories, where we were able to find data. The issue of developing nations is, however, exhibited by the two columns presented in Table 10.

**Table 27. Central values of the results of the monetarisation approach**

Scenario	Impacts identified outside transport sector (but including the production of fuels for transport) (MECU/y)							Impacts from domestic transport sector (MECU/y)		
	Occupational health		Public health		Noise	Greenh.	Greenh. war- ming related	other		
Fatalities	Injuries		Emission-caused damage		&	impacts				
	major	minor	SO <sub>2</sub>	NO <sub>x</sub>	Part.	visual	CO <sub>2</sub> -eq.			
1992-F	28.6	23.5	2.1	246.0	635.0	48.3	0.6	32381.4	3405	18536
1992-D	5.2	14.0	0.5	206.1	577.1	33.8	0.6	30469.5		
2030 ESS-F	10.4	12.6	0.5	24.6	31.3	3.1	17.5	1699.2	120	12900
2030 ESS-D	10.4	12.3	0.5	19.7	15.1	1.9	17.5	956.6		
2050 FMS-F	7.8	12.6	0.5	18.6	23.1	1.9	31.2	3762.5	143	27669
2050 FMS-D	23.4	40.4	1.4	10.5	29.1	0.7	99.1	1406.5		

**Table 28 Some externality range estimates (MECU/y)**

Scenario	deaths	major injuries	minor injuries	SO <sub>2</sub>	NO <sub>x</sub>
1992-F	8.3-65.6	0.7-5.9	107.4-349.1	597.0-1873.0	36.7-162.8
1992-D	5.0-38.9	0.2-1.3	90.0-292.6	542.6-1702.3	25.7-113.9
2030 ESS-F	4.5-35.2	0.2-1.4	10.7-34.9	29.4-92.2	2.3-10.4
2030 ESS-D	4.4-34.3	0.2-1.4	8.6-27.9	14.2-44.5	1.5-6.5
2050 FMS-F	4.5-35.0	0.2-1.4	8.1-26.4	21.7-68.2	1.4-6.4
2050 FMS-D	14.3-112.6	0.5-4.1	4.6-14.9	27.4-85.9	0.5-2.3

Source of uncertainty estimates: European Commission (1996a-f). Estimates pertain to the energy system outside the transport sector (cf. Table 27).

## 5.2 Discussion of detailed results

This section provides details of the collection of partial results for the LCA impact assessment underlying Table 27.

### Greenhouse gas emissions

Table 29 shows the total greenhouse gas emissions for the current energy system and the future scenarios, including those of the transport sector. For the rows giving emissions in Denmark only, the rightmost column adds the expected contribution from materials and international transport. The reason for this method of evaluation is, that our programs allow us to distinguish between emissions in Denmark and abroad, and we have just artificially assumed that all materials and equipment are imported, in order to obtain their contribution separately.

**Table 29. Greenhouse gas emissions of the scenarios (tons per year)**

Scenario	CO <sub>2</sub>	CH <sub>4</sub>	NMVOC	N <sub>2</sub> O	CO	CO <sub>2</sub> -eq.	ext. CO <sub>2</sub> -eq.
1992-F	6.16E+07	1.10E+05	3.98E+04	3.48E+02	7.58E+04	<b>6.59E+07</b>	
1992-D	5.52E+07	5.14E+04	2.84E+04	3.22E+02	4.00E+04	<b>5.61E+07</b>	1.08E+07
2030 ESS-F	4.55E+05	2.97E+04	1.43E+04	2.30E+03	5.76E+04	<b>3.35E+06</b>	
2030 ESS-D	0.00	2.81E+04	1.34E+04	1.93E+03	4.77E+04	<b>1.76E+06</b>	1.59E+06
2050 FMS-F	5.97E+06	1.86E+04	1.79E+04	1.46E+03	1.07E+04	<b>7.19E+06</b>	
2050 FMS-D	3.85E+04	1.80E+04	3.00E+04	4.71E+03	3.78E+03	<b>2.59E+06</b>	6.77E+06
<i>HYPO</i>	1.17E+07	1.62E+04	6.82E+03	6.70E+01	1.16E+04	<b>1.22E+07</b>	

Source: Own calculations, based on TEMIS and spreadsheet calculations.

*HYPO*: this row shows the maximum greenhouse gas emissions permitted, if reduction targets of 80 per cent were to apply for all gases (relative to an average of the two 1992 cases). The assumption underlying the FMS is to achieve a 80% reduction for CO<sub>2</sub> - the other gases are not considered.

The extreme right-hand column "ext. CO<sub>2</sub>-eq." shows, for the three scenarios where only domestic impacts are considered, the CO<sub>2</sub> equivalent emissions from material production and international transport that are not included in the domestic Danish emissions.

Our values for the 1992 system are slightly lower than the official statistics, that estimates about 60 million tons CO<sub>2</sub> emissions for 1992. However, we have not included any corrections for the import of about 14 PJ electricity that took place in 1992. This would translate to an extra amount of about 3 million tons of carbon dioxide.

The last row in Table 29 gives the 80% CO<sub>2</sub> emission reduction, that was the stated goal of the fair market scenario (LTI project group, 1996). It is seen, that both the "F" and the "D" method of evaluating the CO<sub>2</sub> emissions do reach this reduction goal.

It is also seen, that the difference between the two ways of evaluating the emissions (including imports and excluding exports or vice versa) is modest for the current situation, but decisive for the future scenarios. This is because the emission of greenhouse gases (as well as the majority of other impacts) for renewable energy systems is primarily associated with equipment manufacture and not with running the system.

Figure 29 summarises the results of Table 29. The rationale for comparing to a goal of 80% CO<sub>2</sub> emission by year 2050 (a goal that is consistent with the Danish aim to reduce by 20% by 2005 and by 2030 a further reduction of 25% alone in the transportation sector, according to "Energy 21" by the Danish Department of Environment and Energy (1996)) is, that this has been identified by the LTI-group (1996) as necessary for industrialised countries, in order to allow for growth in activities in the developing countries, so that the overall reduction exceeds 50%. Note that we consider the scenario emissions of CO<sub>2</sub>-equivalents, which include other greenhouse gases than CO<sub>2</sub>.

The environmentally sustainable scenario is well below the greenhouse emission goals, whereas the fair market is closer to the limit, considering that some additional use of fossil fuels for backup during winter is required (Sørensen, 1996b).

**Figure 29. Greenhouse emissions of the current system and future scenarios, evaluated with inclusion of imports and exclusion of exports, or vice versa.**

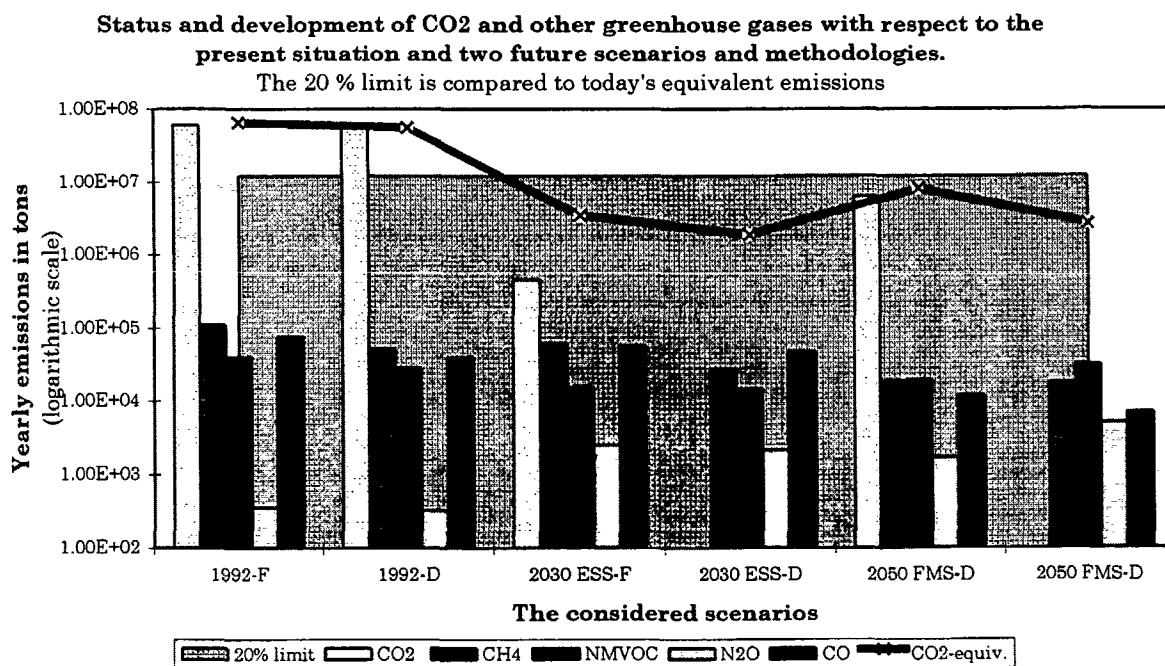

### Air pollution

The emissions of polluting substances like SO<sub>2</sub>, NO<sub>x</sub> and particles are shown in Table 30, for the present case and future scenarios according to the two ways of evaluating. In all cases, there are substantial reductions, typically by more than a factor of ten.

The emission figures are not strictly comparable to official figures. For instance, the results we calculate on the basis of the ExternE project consider specific *state-of-the-art* technology characterised by significantly lower emissions than average technologies used in the present European and Danish energy systems. For example, Fenhann and Kilde (1994, 34) give the current SO<sub>2</sub> emissions as 130,000 t/y for an electricity production of 101 PJ from the Danish

mix of a few pure power stations and many CHP<sup>1</sup> installations (Sørensen *et al.*, 1994, 48). This is equivalent to an SO<sub>2</sub> emission of 4.6 kg/MWh-elec, as compared with the figure of 0.8 kg/MWh-elec used by ExternE for the German Lauffen plant (EC, 1995/3, 84). Taking into account that the Danish plants also produce heat, the average Danish emissions per MWh of energy come down to about two times the ones used by ExternE.

The Lauffen plant is equipped with *state-of-the-art* flue gas desulphurisation (FGD) and NO<sub>x</sub>-reducing de-NOX technologies. A Table in Fenhann and Kilde (1994, 34) indicates a rapid reduction of the Danish SO<sub>2</sub> emissions taking place over the recent years, due to the implementation of cleaning technologies and the substitution of older plants with newer capacity. This is corroborated by data from the technical reports underlying the Danish energy plan Energy 21 (Danish Energy Agency, 1995), showing that total Danish SO<sub>2</sub> emissions have decreased from 350 kt by the mid-1980's to 230 kt at the beginning of the 1990's - the latest figure pertaining to 1994 being 150 kt.

**Table 30. SO<sub>2</sub>, NO<sub>x</sub>, HF, HCl and particles emissions to the air (t/year)**

t/y	Scenario	SO <sub>2</sub>	NO <sub>x</sub>	Particles	HCl	HF
total	1992-F	107416	199676	12638	3789	228
local	1992-D	90016	181486	8845	3583	213
total	2030 ESS-F	10735	9833	807	4	5
local	2030 ESS-D	8590	4743	508	0	0
total	2050 FMS-F	8127	7266	499	2	0
local	2050 FMS-D	4570	9154	178	0	0

Thus, even though our total chain analysis of the 1992 energy system might give too low SO<sub>2</sub> and NO<sub>x</sub> emissions as compared to actual figures for that year, the ongoing development towards cleaner technologies may already have changed the situation to what we have indicated.

Hydrogen production via biomass gasification contributes some SO<sub>2</sub> emissions in the future scenarios, but the highest emissions are caused by the use of fossil fuels for international maritime and air transport.

Table 30 also gives primary particle emissions from combustion processes outside the transport sector. These emissions will be strongly reduced in both scenarios. Reasons for this are the introduction of newer technologies, like fuel cells that liberate very small amounts of particles and the substitution of fossil electricity generating capacity by wind turbines, PV cells and biomass gasification units, where both the process and the end product emit very low amounts of particles.

A large source of particles will still in the future scenarios be both the domestic and the international transport sectors, and particularly in case of the transport-intensive fair market scenario.

<sup>1</sup> CHP: combined heat and power.

### Occupational health and accidents

This section discusses occupational health impacts from accidents occurring in the energy industry. Accidents during transport is treated in the transport sector below. There are relatively few data for the emerging energy sectors associated with the use of renewable energy. In some cases one can exploit similarity to other sectors, such as microelectronics industry for photovoltaic and scaffold work for erection of wind turbines. We have used this method, as illustrated in Figures 24 and 25, but have not extended the approach to morbidity.

Table 31 summarises our findings. For 1992, six people died in connection with coal mining and transport, and three from transport of materials, most of them outside Denmark. The last two occupational deaths were difficult to categorise. Within Denmark there is one industrial accident and one accident during freight transport.

For the future scenarios, a dominating contribution is road accident while travelling to maintain e.g. wind turbines. The number of maintenance trips is taken from the ExternE study, and the figure is higher than customary in Denmark. For the fair market scenario, there is export of hydrogen produced by gasification of biomass, and the relatively high accident figures are related to handling of wood during forestry and conversion.

**Table 31. Accident figures for the scenarios**

Scenario	lives	major	minor
1992-F	11	298	1728
1992-D	2	177	380
2030 ESS-F	4	160	424
2030 ESS-D	4	156	420
2050 FMS-F	3	159	412
2050 FMS-D	9	512	1205

Data in accidents per year

**Table 32. Hydrogen production in fair market scenario**

Scenario	Source	Value
including exports	hydrogen generation from biomass, MJ/y	7.52E+10
excluding exports	hydrogen generation from biomass, MJ/y	6.76E+09

### Exchange of hydropower with Norway.

Despite the fact that both the ecologically sustainable and the fair market scenario contains implicitly some exchange of electricity between e.g. Norway and Denmark, we have not considered this. All in all the effect should be small, but will mean that our values are slightly lower than the real ones for an energy system that takes into account all impacts. Table 33 gives the impacts estimated for the 1992 hydro import, based on ExternE.

**Table 33. Externality costs of hydropower exchange**

	MECU/y	
1992-F	13.30	
1992-D	13.30	
2030 ESS	NQ	
2050 FMS	NQ	NQ = not quantified.

### Wind turbine impacts

Indirect impacts from manufacture of wind turbines are included in the overview in Table 27, where we look at total emissions of *e.g.* SO<sub>2</sub>, NO<sub>x</sub> and the greenhouse effect. However, there are additional direct impacts such as noise and visual intrusion. The data from the European Commission (1995f) have been slightly modified by disregarding the site near a national part (cf. Chapter 4), and the scenario impacts come out as shown in Table 35, with the scenario wind power penetration given in Table 34.

**Table 34. Wind power generation (TWh in scenario year)**

Scenario	off-shore	on-shore	total
1992-F	0.0	0.8	0.8
1992-D	0.0	0.8	0.8
2030 ESS-D	16.9	8.4	25.3
2050 FMS-F	35.8	9.4	45.3
2050 FMS-D	113.6	30.0	143.6

We use the ExternE value of 0.1 mECU/kWh for visual amenity loss from wind turbines but we impose a 0.59 mECU/kWh externality for noise only in connection with on-shore wind turbines. The results are given in Table 35. The dominating noise impacts may go down as a result of technology improvement (in fact the current experience support that) (European Commission 1995f, 53). Other impacts have been identified but are not included here (*e.g.* infra-sound, telecommunication interference, cf. Sørensen, 1981b).

**Table 35. Environmental externality costs of wind turbine electricity (MECU/y)**

scenario	visual impact		noise	sum
	off-shore	on-shore	on-shore	
1992-F	0.00	0.08	0.48	0.56
1992-D	0.00	0.08	0.48	0.56
2030 ESS-D	1.69	0.84	14.93	17.46
2050 FMS-F	3.58	0.94	26.71	31.24
2050 FMS-D	11.36	3.00	84.73	99.09

### Land use and groundwater consumption

Issues of land and groundwater use are chiefly associated with the agricultural sector and the modifications implied by transforming it to a food-and-energy sector. In recent years, a considerable amount of literature on issues of biodiversity have appeared. However, little of it is relevant for Danish conditions, due to both vegetation zone differences and the long tradition for "managed" nature in our country. We have thus judged any attempt in quantifying this impact as premature. As regards groundwater, the physical amounts needed for *e.g.* coal mining activities are well known.

### Transport sector

Our treatment of the transport sector is based on the analysis of road transportation of persons, presented in Chapter 4. We have used simple scaling to include freight transportation, and as regards international traffic by air or sea, we have excluded it because available data on visual impacts, noise and other inconvenience cannot be transferred to open sea or air areas, and the



air pollution impacts are similarly difficult to determine, because of low and altered population densities. The global impact from greenhouse warming is, on the other hand, easy to include. The results for the entire domestic transport sector are given in Table 36, and energy use data and CO<sub>2</sub>-equivalent emissions are given in Table 37.

**Table 36. Identified and quantified impacts of the domestic transport sector.**

Impact type \ scenario	Current	ESS		FMS			
	gasoline	methanol	electricity	methano	biogas	electricity	oil products
car manufacture	875	329	333	534	136	757	
road construction	1291	486	492	788	201	1117	
traffic accidents	5029	1893	1915	3068	781	4351	
noise	1531	576	583	934	238	1324	
envir. & visual impacts	6497	2446	2474	3963	1009	5621	
emission impacts on public health*	1752	192	0	242	62	0	
greenhouse warming impacts	3405	76	44	95	25	23	
barriere effects	1562	588	595	953	243	1351	
Column sum	21941	6586	6435	10576	2692	14543	
<b>Total for scenario</b>	<b>21.941</b>		<b>13.021</b>				<b>27.812</b>

\* for methanol and biogas driven vehicles, air pollution is considered at the same level as for gasoline driven vehicles.

**Table 37. Scenario energy use and greenhouse gas emissions for transport sector**

	Current	ESS		FMS			
	gasoline	methanol	electricity	methanol	biogas	electricity	oil products
<b>Energy use in transport sector</b>							
Total (TWh/y)	48,3	6,1	4,4	5,5	1,4	7,8	17
road	37,4	3,7	3,5	5,5	1,4	5,8	0
dom.rail/air/sea	2,4	0,6	0,9	0,0	0,0	2,0	2
internat.air/sea	8,5	0,8	0,0	0,0	0,0	0,0	15
<b>Greenhouse gas emissions</b>							
t CO <sub>2</sub> -eq/y (road or other domestic)	1,44E+07	3,22E+05	1,87E+05	4,03E+05	1,04E+05	9,66E+04	
t CO <sub>2</sub> -eq/y (all transport)	1,75E+07	4,53E+05	1,89E+05	4,03E+05	1,04E+05	9,66E+04	

## 6. CONCLUSIONS

We have gone through all sectors of the current Danish energy system, plus several new sectors that play a role in the future energy scenarios that we are analysing. With the purpose of determining if there is enough data available to make a meaningful life-cycle analysis of the direct and indirect impacts of the different systems. The data gaps found are easiest to discuss on a component by component basis, because the chains of conversion processes that would be considered in a product LCA would double count the same components over and over.

For end-use conversion processes there is only limited data. These may come from industrial activities where an LCA for a specific product happens to have been made (e.g. insulation material). The situation is similar for electric appliances. For boilers and furnaces the emissions of pollutants and greenhouse gases are well known, and we have used a standard translation of these into impacts, based on power plants, but knowing that this is at best a lower limit estimate, because the emission height is typically smaller than for power plants. For the transport sector, there are a number of LCA's available, and these confirm the dependence on emission height, giving higher damage estimates per unit of emitted substance than the power plant estimations. Impacts from road accidents are well mapped, and also as regards impacts associated with noise and social inconveniences (e.g. barrier effects, visual impacts), there is a considerable volume of data for the transport sector.

For power plants and other intermediate conversion there is a substantial amount of data, both for current technology (usually taken as state-of-the-art) but also for emerging technologies. This is only natural, as the emerging renewable energy technologies must prove the gut-feeling that they are environmentally benign. Particularly for some of the biofuel technologies there is still considerable scientific debate on these issues, due to the intertwining of the energy issues with general questions of sustainable agriculture and forestry. Most of the data for conventional technologies are not LCA data, but this is defended by arguing that the most important impacts are included, and they occur during actual combustion and not indirectly. For renewable energy systems, indirect impacts - e.g. occurring during manufacture of photovoltaic cells or wind turbines - are often the most important ones.

Impacts occurring during transport (of materials, fuels and maintenance crews) can be estimated using the data from the transport sector. For pipeline and cable transmission, we have found only sporadic data.

For primary energy extraction (mining or other fossil extraction techniques, and biomass harvesting), we have found relatively good data for specific fossil fuel mines, but little for agriculture. To this comes the impacts during refining, treatment or similar "initial" processes, where again we have not found much data on emerging technologies, except energy pay-back times.

We have then quantified and monetised all system-wide impacts for which we had data, obtaining what clearly must be considered a sub-total of the real impacts. It is still our belief that we have caught the most important impacts throughout the energy system, with the exception of end-use impacts outside the transport sector, where impacts (like for the transport sector) are as much impacts from our life-style *per se*, than specifically for the energy system.

There are two major methodological lessons of the present work: one is that a system-wide LCA cannot be performed by use of the chain calculations customary in conventional product LCA's, without double counting. Exchange of energy or other products between the facilities in the energy system has to be corrected for in order to avoid double counting, and particularly if end-use impacts are studied, any energy use by industry, households or commerce would lead to double-counting of those impacts already calculated for energy production. Because many of our sources used the chain point of view, we had to deal with these issues by special corrections, being helped by the fact that a full analysis of end-user impacts was anyway not possible. In the future, we would recommend data-collection (energy and materials/effluents input and output) on a facility by facility basis. In fact much data is already collected in this form, but is aggregated before publication or database release.

The other methodological lesson pertains to the difference between the product and the economy view of impacts. Both can be consistently calculated, the product view including impacts from imported goods, but excluding those of exported goods, and the economy view *vice versa*. There is an ongoing discussion of these issues in connection with the proposed CO<sub>2</sub> emission permits, where e.g. Norway would like not to bear the burden of the emissions occurring during the oil and gas (for export) extraction processes. A piece in this discussion is also that it will presumably never be possible to determine the impacts associated with imports from countries lacking in environmental and safety statistics. We would like - perhaps a little controversially - to propose that future assessments are done from the domestic economy point of view. This is a natural transition towards making LCA assessment of all activities within our economy, not just energy activities, and it could well be accompanied by giving results of the product point of view during a transition period. In our chosen cases, the difference between the two methods of calculations, calculated with slight modifications explained in chapter 5, is that the product view externalities are 20% higher than the Danish economy figures for the current energy system, 100% higher for the 2030 ecologically sustainable scenario, and 280% higher for the 2050 fair market scenario.

However, by both methods of calculation, the expected outcome is confirmed: that the impacts from the future renewable energy intensive scenarios are more than an order of magnitude lower than those of the current system, even in the product view. We are quite certain of this conclusion, as we have taken a conservative view throughout, in estimating impacts from renewable energy technologies. Many of these technologies are not mature yet, and we have been cautious in extrapolating current development trends. Any breakthrough in technology, e.g. for PV-cells, would most likely go in the direction of lowering environmental impacts.

The recent Energy 21 plan from the Danish government came too late for us to include in the calculations. However, as it goes about half as far in the renewable energy transition as the ESS-scenario, we would expect a similar LCA externality reduction, or a factor of about 0.65 in the economy view. In closing this line of argument, we would once more like to point the attention to the statistical value of life, 2.6 MECU, taken from the European Commission's ExternE study and used in our calculation. A discussion of its uncertainty is given in chapter 4, where we estimate the maximum plausible downward correction as a factor of two.

## Literature

- Arbejderbevægelsens Erhvervsråd: 1995, *Grøn Vækst*, Clemmesen, F. (ed.), AER, København, 162 pp.
- Arbejdstilsynet: 1992, *Anmeldte arbejdsulykker. Årsopgørelse 1991 foreløbig Udgave*, København
- Ahrentzen, P.: 1974, *Jordartsbeskrivelse*, SV interne notater 32, Statens Vejlaboratorium, Roskilde, 10 pp. (+app.).
- Alcamo, J., Shaw, R., and Hordijk, L. (eds.): 1990, *The RAINS model of acidification: science and strategies in Europe*, Kluwer Academic Publ., Dordrecht.
- Alexandersson, A., Flodström, E., Öberg, R., and Stålberg, P.: 1991, *Sjöfartens utsläp av avgaser*, TFB-Report 1991:18, Swedish Transport Reserach Board, Stockholm, 237 pp.+ 5p appendixes.
- Almeida, A.T. de, Rosenfeld, A.H., Roturier, J., and Nørgård, J. (eds.): 1994, *Integrated Resource Planning. Proceedings of the NATO Advanced Research Workshop on Models for Integrated Electricity Resource Planning*. Espinho, Portugal, June 28-July 2, 1993, Kluwer Academic Publishers, Dordrecht, 528 +8 pp.
- Amann, M. and Dhoondia, J.: Regional Air Pollution Information and Simulation (RAINS-Asia), User's manual, 34 pp. World Bank and IIASA, Laxenburg.
- Andersen, F.M., and Trier, P.: 1995, 'Environmental satellite models for ADAM. CO<sub>2</sub>, SO<sub>2</sub>, and NO<sub>x</sub> emissions', *NERI Technical Report No. 148*, National Environmental Research Institute, Risø, 200 pp.
- Andersen, P., Bidstrup, C., Djernis, H.G., Hjorth-Caspersen, O., Jeppesen, R., Nielsen, P., Palludan-Müller, G., and Zeuther, J.: 1990, *Miljø og energi i Polen*, LFM, København, 97 pp.
- Anonymous: 1996, 'Smog "kills 60,000 a year"', *Nature* **381**, 185.
- Ashley, H., Rudman, R.L., and Whipple, C. (eds.): 1976, *Energy and the Environment: A Risk Benefit Approach*, Pergamon Press, New York, 305 pp.
- Asman, W.A.H., Brown, N., Runge, E.H., Tekiela, M., Eriksen, P.B., Christiansen, M.: 1995, *MeMos. Udvikling af en konsekvensmodel for svovldeposition for Sydkandinavien*, Faglig Rapport fra DMU, nr. 149, Danmarks Miljøundersøgelser, 57 pp.
- Atlung, G.: 1980, 'Sundhedsfarer ved plastforarbejdning. En vejledning til sikrere materialehåndtering og procesgennemførelse. Del I: to-komponent hærdeplast, Del II: termoplast', *Rapport Nr. P.80.27*, Laboratoriet for plastteknologi, DTH, Lyngby, 132 pp.
- Auken, S.: 1996, 'Energiafgifter har fordele', *Kristeligt Dagblad*, 14. mar. 1996, p 4.
- Automobilimportøren: 1992, *Vejtransporten i tal og tekst 1992*, Automobilimportørenes Sammenlutning, København.
- Aylward, B.: 1995, 'The role of plant screening and plant supply in biodiversity conservation, drug development and health care', in Swanson (1995a) *Intellectual Property Rights and Biodiversity Conservation*, pp. 93-126.
- Baisnée, P.-F.: 1993, 'Life Cycle Assessment of energy systems, and energy in Life Cycle Assessment. Some methodological problems', in *OECD 1993a*, pp. 182-186.
- Bannister, D., and Button, K. (eds.): 1993, *Transport, the Environment and Sustainable Development*, E&FN Spon, London, 275 pp..
- Baratta, M. von.: 1995, *Der Fischer Weltalmanach '96*, Fischer, Frankfurt am Main, 1280 columns.
- Basis: 1993, *BASIS Emneleksikon*, Høst & Søns Forlag, København, 792 pp.
- Bygge-, Anlægs- og Trækartellet: 1996, *Alternativ Isolering. Papiruld, perlite, polystyren ja tak!*, BAT, København, 68 pp.
- Baumann, A.E., and Hill, R.: 1993, 'Quantification of external costs of energy technologies applied to photovoltaic life-cycle analysis', in *OECD 1993*, 143-150.
- Baumbach, G.: 1994, *Luftreinhaltung*, Springer, Berlin, 461 pp.

- Benestad, O., Kristiansen, A., Selvig, E., Westskog, H., Emborg, L., Meyer, N.I. and Brinck, L., 1991: *Energi 2030. Lavnergiscenarier for Danmark, Norge og Sverige*, Alternativ Framtid, Oslo, pp. 87 (+94 pp. notes).
- Biesiot, W., and Moll, H.C. (eds.): 1995, *Reduction of CO<sub>2</sub> emissions by lifestyle changes. Final report to the NRP Global Air Pollution and Climate Change*, IVEM research report nr. 80 (revised), Groningen-Utrecht, 113 pp.
- Bindner, H., and Søndergaard, L.: 1995, 'Undersøgelse af generatorkoncepter til vindmøller - opsummeringsrapport', *Risø-R-857*, Risø National Laboratory, Roskilde, 15 pp.
- Bond, M.: 1996, 'Dirty ships evade acid rain controls', *New Scientist*, 22 June 1996, p. 4.
- Brinck, L., Emborg, L., Juul-Kristensen, B., Kristiansen, A., Pulliainen, K., Selvig, E., Vaittinen, A., and Benestad, O.: 1991, 'Miljö och energi i Norden. energiscenarier för år 2010', *NORD 1992: 548*, Nordisk Ministerråd, København/DK, pp. 167+app..
- Brockhoff, L., Jørgensen, N.O., Styhr Petersen, H.J., and Wiuff, R.: 1994, 'Transport af farligt gods i Danmark', *Notat 94-01*, Transportrådet, København, 41 pp.
- Buck Jr., D.E., and Rabchevsky, G.A.: 1988, *The Mineral Industries of Belgium, Luxembourg, And The Netherlands. 1988 International Review*, U.S. Department of the Interior, Bureau of Mines, Washington 35 pp.
- Bunker, S.G.: 1995, 'Flimsy joint ventures in fragile environments', in Barham, B., Bunker, S.G., and O'Hearn, D. (eds.): 1995, *States, Firms, and Raw Materials. The World Economy and Ecology of Aluminium*, The University of Wisconsin Press, Madison 341 pp.
- Bureau of Land Management: 1980, *Department of the Interior Draft. Environmental Impact Statement of the Energy Transportation Systems Inc. Coal Slurry Pipeline Transportation Projekt. Prepared by BLM (Lead Agency) and Woodward-Clyde Consultants*, Traylor, R.E. (ETSI EIS Project Leader), 409 pp. (+appendix 170 pp.).
- Børgeson, C.D., Christensen, F., Damgaard, T.A., Dreyer, R., Grenzlikowski, J., Højer, M., and Jacobsen, N.B.: 1992, *Bæredygtighed og biogas i energiforsyningen - Kan det bære, eller er det bare gas? En føljeton i 3 dele*, april 1992, Vejleder: Karen Eberhardt Henriksen, KVL, Lærestalernes Fælles Miljøkursus, København, 98 pp + app.
- Börjesson, P.I.I., and Gustavsson, L.: 1996b, 'Regional production and utilization of biomass in Sweden', *Energy* 21 (9), 747-764.
- Börjesson, P.I.I.: 1996, 'Emissions of CO<sub>2</sub> from biomass production and transportation in agriculture and forestry', *Energy Convers. Mgmt.* 37 (6-8), 1235-1240.
- Börjesson, P.I.I.: 1996a, 'Energy analysis of biomass production and transportation', accepted in *Biomass and Energy*, 18 pp.
- Caldeira, K., and Kasting, J.F.: 1993, 'Insensitivity of Global Warming Potentials to Carbon Dioxide Emission Scenarios', *Nature* 366, 251-3.
- Caldeira, K.: 1996, 'IPCC report, chapter and verse', *Nature* 383, 214.
- Charlson, R. J., Langner, J., Rodhe, H., Leovy, C. B. and Warren, S. G.: 1991, 'Perturbation of the Northern Hemisphere Radiative Balance by Backscattering from Anthropogenic Sulphate Aerosols', *Tellus* 43 AB, 152-163.
- Christensen, L and Gudmundsen, H (1993). *Bilismens fremtid*. Danish Technology Council Report 93/3, Copenhagen
- Clements, J.R.: 1994, 'Coalbed methane - The cleanest coal utilization yet', in *IEA 1994e*, 487-494.
- Cline, W. 1992. *Global Warming: the Economic Stakes*. Inst. Int. Economics. Washington DC., 399 pp.
- Coker, A., and Richards, C. (eds.): 1992, *Valuing the Environment. Economic Approaches to Environmental Evaluation. Proceedings of a Workshop held at Ludgrove Hall, Middlesex Polytechnic on 13 and 14 June 1990*, Belhaven Press, London, 183 pp.

- Commission of the European Communities: 1986, *Organo-chlorine solvents. Health risks to workers*, Luxembourg, 252 pp.
- Commission of the European Communities: 1988, *Solvents in common use. Health risks to workers*, Luxembourg, 308 pp.
- Commission of the European Communities: 1990, *Long-term neurotoxic effects of paint solvents*, Luxembourg, 35 pp.
- Commission of the European Communities: 1992, *Green Paper on The Impact of Transport on the Environment. A Community strategy for "sustainable mobility"*, KOM(92) 46, Communication from the Commission, Brussel, 73 pp.
- Commoner, B., Boksenbaum, H., and Corr, M.: 1975a, *The Social Costs of Power Production, Energy and Human Welfare – A Critical Analysis, Volume I*, Scientists Institute for Public Information, Macmillan Information, New York, 217 pp.
- Commoner, B., Boksenbaum, H., and Corr, M.: 1975c, *Human Welfare: The End Use for Power, Energy and Human Welfare – A Critical Analysis, Volume III*, Scientists Institute for Public Information, Macmillan Information, New York, 185 pp.
- Connor-Lajambe, H., Kuemmel, B., Nielsen, S.K., and Sørensen, B.: 1996, '2nd Annual report from the project Life-cycle analysis of the total danish energy system. Assessment of the present Danish energy system and selected future scenarios, using methods developed in international projects to which this project, performed for the Danish Energy Agency, is linked', *Tekster fra IMFUFA Nr. 311*, Roskilde Universitetscenter, 276 pp.
- Consoli, F. et al. (eds.), 1993, *Guidelines for Life-cycle Assessment: A code of Practice*. Society of Environmental Toxicology and Chemistry (SETAC).
- Consroe, T.J., Glaser, F.M., and Shaw Jr., R.W.: 1976, 'Potential Environmental Impacts of Solar Heating and Cooling Systems', *EPA 600/7-76-014*, U.S.-EPA, Office of Research and Development, Washington D.C., 111 pp.
- Costanza, R., Kemp, M., and Boynton, W.: 1995, 'Scale and biodiversity in coastal and estuarine ecosystems', in Perrings *et al.*, *Biodiversity loss*, pp. 84-125.
- COWI: 1988a, *Dansk Transport 2010. Energiforbrug af miljøforhold. Sammenfattende rapport. Energiministeriets Forskningsprogram 87. Energianvendelse i transportsektoren*, COWIconsult, Lyngby, 112 pp.
- COWI: 1988b, *Dansk Transport 2010. Energiforbrug af miljøforhold. Bilag. Energiministeriets Forskningsprogram 87. Energianvendelse i transportsektoren*, COWIconsult, Lyngby/DK, pp. 126.
- CRU/WWF/SMA: 1992, *Climate Change due to the Greenhouse Effect and its Implications for China*, Hulme, M., Wigley, T., and Jiang, T. (Climate Research Unit), Zhao, Z.-ci, Wang, F., and Ding, Y. (Chinese Academy of Meteorological Sciences), Leemans, R. (National Institute for Public Health and Environmental Protection), Markham, A. (WWF International), World Wildlife Fund, Gland/CH, pp. 56.
- Damlund, M., Gøth, S., Hasle, P., and Munk, K.: 1983, *Nedslidning i jord- og betonarbejdet - et frit men hårt erhverv*, Arbejdsmiljøfondets forskningsrapporter, Arbejdsmiljøfondet, Copenhagen/DK, pp. 214.
- Danish Department of Environment and Energy: 1996, *Energy 21, the Danish Government's action plan for energy*, Copenhagen.
- Danish Department of Public Works (1987). *Trafikundersøgelse 1986*. Copenhagen
- Danish Energy Agency, 1995: *Energistatistik 1994*, Energistyrelsen (ed.), København, 31 pp.
- Danish Energy Agency 1995a: *Technology Data for Power and Heat Production Systems* (in Danish), Energistyrelsen, Copenhagen, May 1995, pp. 88.
- Danish Energy Agency: 1995b, *Progress Report on The Economy of Centralized Biogas Plants*, Energistyrelsen, Copenhagen, pp. 34.

- Danish Energy Agency: 1996, *Energistatistik 1995*, Energistyrelsen (ed.), København, pp. 24.
- Danish Energy Agency: 1996a, *Biomass for energy - Danish solutions*, Energistyrelsen, June 1996, København, pp. 34.
- Danish Environmental Protection Agency: 1992, 'Forstudie til livcyklusanalyse inden for transportsektoren', *Arbejdsrapport fra Miljøstyrelsen Nr. 47 1992*, COWIconsult A/S, Miljøministeriet, Miljøstyrelsen, København, pp. 15.
- Danish Environmental Protection Agency: 1995, 'Eco-Labeling and Transportation', *Arbejdsrapport fra Miljøstyrelsen Nr. 12. 1995*, COWIconsult A/S, Planners AS, Miljøstyrelsen, København, pp. 15.
- Danish Geological Surveys: 1994, *Grundvandsovervågning 1994*, Miljø- og Energiministeriet, Danmarks Geologiske Undersøgelser (eds.), Geografforlaget Aps, Brendstrup, pp.59 (+5 app.).
- Danish Road Directorate (1981). *Trafikulykker 1980*. Copenhagen
- Danish Statistical Office (1993). *Miljø Report 93/1*, Copenhagen
- Danmarks Statistik: 1992, *Statistisk Årbog*, København, 566 pp.
- Danmarks Statistik: 1993, 'Industriens omsætning 4. kvartal 1992', *Industri og Energi*, 1993:5, København
- Danish Technology Council: see also "Teknologinævnet"
- Danish Technology Council: 1993. *Trafikkens Pris*. Copenhagen.
- Danish Technology Council, 1994: see Sørensen et al., 1994.
- Danish Transport Council (1993). *Externaliteter i transportsektoren*. Report 93-01, Copenhagen
- Danske Elværkers Forening: 1993, *Dansk Elforsyning. Statistik 1992. Elsparevaner*, DEF, Frederiksberg, 52 pp.
- Danske Elværkers Forening: 1996, *Dansk Elforsyning. Statistik 1995*, DEF, Frederiksberg, 68 pp.
- Davison, W., George, D.G., and Edwards, N.J.A.: 1995, 'Controlled reversal of lake acidification by treatment with phosphate fertilizer', *Nature* 377, 504-507.
- Det Økonomiske Råd: 1996, *Dansk Økonomi. Forår 1996*, Det Økonomiske Råd, København/DK, chapter on the transport sector, 93-161.
- Diercke: 1988, *DIERCKE Weltatlas. 1. Auflage der Neubearbeitung*, U. Zahn (Leitung), Westermann Kartographie, Westermann Schulbuchverlag, Braunschweig/DE, pp. 275.
- Doan, D.B., Chin, E., Kinney, G.L., and Yen, D.: 1988, *The Mineral Industries of South Asia. 1988 International Review*, U.S. Department of the Interior, Bureau of Mines, Washington/US, pp. 50.
- Dogniaux, R. (ed.): 1994, *Prediction of Solar Radiation in Areas with a Specific Microclimate*, Commission of the European Communities, Kluwer Academic Publishers, Dordrecht/NL, pp. 107.
- Dolley, T.P., and Michalski, B.: 1988, *The Mineral Industries of North Africa. 1988 International Review*, U.S. Department of the Interior, Bureau of Mines, Washington/US, pp. 37.
- DONG: 1994, 'Energi i tal og figurer. Bilag til Redegørelse til Folketinget', Dansk Olie og Naturgas' informationsafdeling (ed.), Hørsholm, 36 pp.
- Dones, R., Hirschberg, S., and Knoepfel, I.: 1994, *Greenhouse gas emissions inventory based on full energy chain analysis*, Paper presented at IAEA Workshop/Advisory Group Meeting on: 'Full energy-chain Assessment for Nuclear and other energy sources' Beijing, China, 4-7 October 1994, Paul Scherrer Institut, Villingen, 23 pp.
- Dybdedal, P.: 1992, *Godstransport og miljø - drivkrefter og udviklingsbaner*, TØI Rapport 0107/1992, Transportøkonomisk institutt, Oslo/NO, pp. 60.
- E&M: 1991, *Energi og Miljødata*, Energi og Miljødata, Aalborg/DK, pp. 11.
- Edens, J., Vendrup, M., and Simonsen, N.: 1993, 'Elimination of Water Pollution from Desulfurization', in *IEA 1993a*, pp. 131-142.

- Egglestone, H.S., Gorissen, N., Jourmard, R., Rijkeboer, R.C., Samaras, Z., and Zierock, K.H.: 1989, *CORINAIR working group on emission factors for calculating 1985 emissions from road traffic. Volume 1: Methodology and emission factors. Environment and quality of life. Final report EUR 12260 EN*. Commissions of the European Communities. Brussel/BE, Luxembourg/LU.
- Ekelund, M.: 1994, 'The Co-Nordic natural gas bus project', in *IEA 1994a Natural Gas Technologies*, 353-361.
- Eketorp, S.: 1976, 'Energy Considerations in Reduction Processes', in Szekely, J. (ed.) *The Future of the World's Steel Industry*, Marcel Dekker, Inc, New York/US and Basel/CH, pp. 139, 23-43.
- Ell, R.: 1996, 'Kälte aus der Luft. FCKW-freie Klimaanlage finden immer mehr Abnehmer', *Süddeutsche Zeitung*, 11. april 1996.
- ELSAM: 1995, *Miljøberetning 1995*, ELSAM-fællesskabets miljøpolitik, ELSAM, Planlægningsafdelingen, Fredericia/DK, pp. 23.
- ELSAM: 1996, *Prissætning af miljøeffekter ved kulfyret elproduktion*, NOTAT SP96-477a, Fredericia, 17 pp.
- Energiministeriet: 1990, *Energi 2000. Handlingsplan for en bæredygtig udvikling. Bilag*, Energiministeriet, København/DK, pp. 68.
- Energistyrelsen: 1992, *Statusrapport for Biogasfællesanlæg*, Energistyrelsen, København/DK, pp. 31.
- Energistyrelsen: 1995, *Danmarks Energifremtider*, Miljø og Energiministeriet, Energistyrelsen, København/DK, pp. 215.
- Energistyrelsen: 1995a, *Teknologidata for el- og varmeproduktionsanlæg*, Energistyrelsen, København/DK, pp. 77.
- Englund, A., Ringen, K., and Mehlman, M.A.: 1986, *Advances in modern environmental toxicology. Volume II. Occupational health hazards of solvents. Revised edition*, Princeton Scientific Publishing Co. Inc, Princeton/US, pp. 259.
- Enting, I.G., and Pearman, G.I.: 1987, 'Description of a One-Dimensional Carbon Cycle Model Calibrated Using Techniques of Constrained Inversion', *Tellus* **39B**, 459-76.
- European Commission: 1994, *Biofuels*, DG XII, Report EUR 15647 EN, Brussels.
- European Commission: 1995, *Europe's environment: Statistical compendium for the Dobris assessment*, Office for Official Publications of the European Communities, Luxembourg, 455 pp.
- European Commission: 1995a, *ExternE: Externalities of Energy, Vol. 1: Summary*, prepared by ETSU for DGXII: Science, Research & Development, Study EUR 16520 EN, Luxembourg, 179 pp.
- European Commission: 1995b, *ExternE: Externalities of Energy, Vol. 2: Methodology*, prepared by ETSU and Metronomica for DGXII: Science, Research & Development, Study EUR 16521 EN, Luxembourg, 571 pp.
- European Commission: 1995c, *ExternE: Externalities of Energy, Vol. 3: Coal and lignite*, prepared by ETSU and IER for DGXII: Science, Research & Development, Study EUR 16522 EN, Luxembourg, 571 pp.
- European Commission: 1995d, *ExternE: Externalities of Energy, Vol. 4: Oil and gas*, prepared by ETSU and IER for DGXII: Science, Research & Development, Study EUR 16523 EN, Luxembourg, 426 pp.
- European Commission: 1995e, *ExternE: Externalities of Energy, Vol. 5: Nuclear*, prepared by CEPN for DGXII: Science, Research & Development, Study EUR 16524 EN, Luxembourg, 337 pp.
- European Commission: 1995f, *ExternE: Externalities of Energy, Vol. 6: Wind and hydro*, prepared by EEE and ENCO for DGXII: Science, Research & Development, Study EUR 16525 EN, Luxembourg, 249 pp.
- Eurostat: 1995, *Europe's Environment. Statistical Compendium for the Dobris Assessment*, Eurostat, European Commission, European Environment Agency Task Force, DG XI and PHARE European Commission, UN-ECE, OECD, WHO, Luxembourg/LU and Brussel/BE, pp. 455.



- Fankhauser, S.: 1995, *Valuing Climate Change. The economics of the greenhouse*, Earthscan, London/UK, pp. 180.
- Feldmeier, H.: 1996, 'Seuchen durch Menschenhand. Solange das Ebolavirus in seiner ökologischen Nische bleibt, ist es relativ ungefährlich', *Süddeutsche Zeitung* (176), 1. august 1996, p. 20.
- Fenger, J., Fenhan, J., and Kilde, N.: 1990, 'Danish Budget for Greenhouse Gases', *NORD 1990:97*, Nordic Council of Ministers, Copenhagen, 116 pp.
- Fenhan, J., and Kilde, N.: 1994, 'Inventory of Emissions to the Air from Danish Sources', Systems Analysis Department, Risø National Laboratory, Roskilde 111 pp.
- Fischer, B., Herken-Krauer, J.-C., Lücke, M., and Nunnenkamp, P.: 1988, *Capital-intensive industries in newly industrializing countries: the case of the Brazilian automobile and steel industries*, J.C.B. Mohr, Tübingen/DE, pp. 325.
- Formidlingsrådet: 1989, *Forbehandling af biobrændsel. Decentrale kraftvarmeværker. Udarbejdet for Formidlingsrådet af Krüger A/S*, Industriministeriet, Industri- og Handelsstyrelsen, Formidlingsrådet, København/DK, pp. 93+diverse maps.
- Frankhauser, S. 1990. *Global warming damage costs - some monetary estimates*. CSERGE GEC Working paper 92/29. Univ. East Anglia
- Fritsche, U., Rausch, L., and Simon, K.-H.: 1989, 'GEMIS: Konzeptionen und Ergebnisse', *Öko-Mitteilungen* 2/89, Öko-Institut, Darmstadt/DE, 35-38.
- Fritsche, U.: 1990, 'GEMIS: wie weiter?', *Öko-Mitteilungen* 1/90, Öko-Institut, Darmstadt, 22-23.
- Füleki, S.: 1993, 'Experiences with the Energy Production in Hungary, Based on Low-Rank Coal', in *IEA 1993a*, pp. 351-367.
- Ganey, P.W., and Reynolds, J.E.: 1988, *Reed's marine distance tables*, Thomas Reed Printers Ltd, Sutherland/UK, pp. 203.
- Garen: 1988, cited in Oak Ridge National Laboratory and Resources for the Future, 1992, *Damages and benefits of the coal fuel cycle: estimation methods, impacts, and values. Draft. Prepared for the U.S. Department of Energy and the European Commission. August 1992*, p. 5-7.
- Gates, D.M.: 1993, *Climate Change and Its Biological Consequences*, Sinauer Associates Inc., Sunderland, MS/US, pp. 280.
- GEMIS: 1992, *Gesamt-Emissions-Modell Integrierter Systeme (GEMIS) Version 2.1, Erweiterter Endbericht im Auftrag des Hessischen Ministeriums für Umwelt, Energie und Bundesangelegenheiten*, Öko-Institut Darmstadt/DE, and GH Kassel/DE, pp. 226.
- Giæver Tande, J.O., and Hansen, J.C.: 1991, *The Economics of Wind Power in Local Power Systems. General framework, fuel savings and capacity values*, RISØ-M-2928, Risø National Laboratory, Roskilde/DK, pp. 20.
- Global: 2000, *Global 2000. Der Bericht an den Präsidenten*, Reinhard Kaiser (ed.), [Original titel: The Global 2000 Report to the President, Council on Environmental Quality and the U.S. Department of State, Gerald O. Barney, (study director)], Zweitausendeins, Frankfurt /Main/DE, pp. 1508.
- Gosk, E., Nygaard, E., and Lundsgaard, A.: 1990, 'Status for grundvand og drikkevand i Danmark 1990. Vandmiljøplanens overvågningsprogram.', DGU, Intern rapport nr 45, 1990, København/DK, pp. 127.
- Gottinger, H.W.: 1991, *Uncertainty, Value of Information and Greenhouse Gas Emissions*, Oxford Institute for Energy Studies, Oxford/UK, pp. 44.
- Gransell, H. and Ekelund, M.: 1992, *The Life of Fuels. Motor Fuels from Source to End Use. An energy and emissions systems study of conventional and future options*, Ecotrafic, Stockholm/SE, pp. 179.
- Grill, A.: 1996, 'Edler Dreck aus dem Auspuff. Platin gilt inzwischen als ungefährlich, doch für Katalysatoren wird zunehmend allergie-auslösendes Palladium eingesetzt', *Süddeutsche Zeitung*, 24. October 1996, p. V.

- Grossling, B.: 1979, *World Coal Resources*, The Financial Times Ltd, London/UK, pp. 164.
- Grubb, M.: 1996, Purpose and function of IPCC, *Nature*, **379**, p. 108; response to news items in *Nature*, **378**, p. 322 (1995) and *Nature*, **378**, p. 119 (1995).
- Guderian, R. (ed.): 1985, *Air Pollution by Photochemical Oxidants. Formation, Transport, Control, and Effects on Plants*, Ecological Studies 52, Springer, Berlin/DE, pp. 346.
- Gustavsson, L., and Johansson, B.: 1994, 'Cogeneration: one way to use biomass efficiently', *Heat Recovery Systems & CHP* **14** (2), 117-124.
- Gustavsson, L., Börjesson, P.I.I., Johansson, B., and Svenningsson, P.: 1995, 'Reducing CO<sub>2</sub> emissions by substituting biomass for fossil fuels', *Energy* **20** (11), 1097-1113.
- Hahne, E., Kübler, R., and Kallweit, J.: 1989, 'The evaluation of thermal stratification by exergy', in Kilkis and Kakac (eds.) *Energy storage systems*, Kluwer, 465-485.
- Hall, D.: 1994 'Biomass energy options in Western Europe (OECD) to 2050', in *OECD 1994a, Energy Technologies to reduce CO<sub>2</sub> emissions in Europe*, pp. 159-193.
- Halsnæs, K., and Meyer, H.: 1994, 'Samfundsøkonomiske omkostninger ved reduceret drivhusgasudslip. Sammenligning af investeringer i reduceret drivhusgasudslip i energisektoren, landbruget, transportsektoren og andre væsentlige drivhusgaskilder', Forskningscenter Risø, Danmarks Miljøundersøgelser, Afdeling for Systemanalyse, *Arbejdsrapport fra Miljøstyrelsen Nr. 49 1995*, Miljø- og Energiministeriet, Miljøstyrelsen, pp. 172.
- Hammit, J.K., Jain, A.K., Adams, J.L., and Wuebbles, D.J.: 1996, 'A welfare-based index for assessing environmental effects of greenhouse-gas emissions', *Nature* **381**, 301-303.
- Hammit, J.K., Jain, A.K., Wuebbles, D.J., and Adams, J.L.: 1996a, 'Costing the Earth', *Nature* **383**, 571.
- Hansen, P.H.: 1996, 'Vandværker vil have støtte til økobønder', *Information*, 4. okt. 1996, p. 4.
- Harral, C.G. (ed.), Cook, P. and Holland, E.: 1992, 'Transport Development in Southern China', *World Bank Discussion Papers*, 151, New York/US, pp. 196.
- Havnearbejdere: 1980, *Arbejds miljø og sundhed på Århus Havn*, "Denne rapport er udarbejdet af havnearbejdere fra Århus i samarbejde med en gruppe medicinstuderende fra Århus Universitet og en gruppe arbejdsmiljøstuderende fra Roskilde Universitetscenter", pp. 64.
- Hayes, P. and Smith, K. (eds.): 1993, *The global greenhouse regime. Who pays?*, The United Nations Library, Earthscan, London/UK, pp. 382.
- Hedin, L.O., Granat, L., Likens, G.E., Buishand, T.A., Galloway, J.N., Butler, T.J. and Rodhe, H.: 1994, 'Steep Declines in atmospheric Base Cations in Regions of Europe and North America', *Nature* **367**, 351-4.
- Hegerl, G.C., Storch, H. von, Hasselmann, K., Santer, B.D., Cubasch, U., and Jones, P. D.: 1994, 'Detecting Anthropogenic Climate Change with an Optimal Fingerprint Method', *Max-Planck-Institut für Meteorologie Report No. 142*, Hamburg/DE, pp. 59.
- Hendriks, C.A., Blok, K., and Turkenburg, W.C.: 1989, 'The recovery of carbon dioxide from power plants', in Okken *et al.* (eds.), *Climate and Energy*, 125-142.
- Herrstedt Jensen, A.H., Winge, U., and Broberg, O.: 1992, 'Miljø- og arbejdsmiljøvurdering af materialer', *Miljøprojekt nr. 204*, Miljøministeriet, Miljøstyrelsen, København/DK, pp. 158.
- Hertel, O., and Hovmand, M.F.: 1991, 'Rural Ozone measurements in Denmark, 1985-1989', *NERI Technical Report No. 35*, National Environmental Research Institute, Risø/DK, pp. 23.
- Hertel, O.: 1991, 'Kemiske reaktioner i atmosfærens grænselag. Modeller for afsætningen af kvælstofforbindelser ved jordoverfladen. Rapporten for studieophold ved Universitetet i Bergen, Geofysisk Institutt, afd. for Meteorologi', *Faglig rapport fra DMU, nr. 34*, Danmarks Miljøundersøgelser, Roskilde/DK, pp. 27.
- Hinsch, C.: 1996, The disposal of wind energy converters and its influence on the life-cycle phases, pp. 173-176 in *1996 European Union Wind Energy Conference*, Stephens & Assoc., Bedford.

- Hirschberg, S., Dones, R., and Kypreos, S.: 1994, *Comprehensive assessment of energy systems: approach and current results of the Swiss activities*, Invited paper presented at Jahrestagung Kerntechnik '94 17-19 May 1994, Stuttgart, Paul Scherrer Institut, Villingen, 30 pp.
- Hjelmer, O., Aagaard Hansen, E., Larsen, F., and Thomassen, H.: 1991, *Leaching and Soil/ Ground-water Transport of Contaminants from Coal Combustion Residues*, Vandkvalitetsinstitut, Hørsholm/DK, pp. 176.
- Hoeller, P. and Coppel, J.: 1992, 'Energy Taxation and Price Distortions in Fossil Fuel Markets: Some Implications for Climate Change Policy', *Economics Department Working Papers No. 110*, OECD, Paris/FR, pp. 25.
- Hoften, S. van: 1994, 'Low-Grade Coal Upgrading: Application of the Liquids from Coal (LFC) Technology to Coals in the Pacific Rim', in *IEA 1994e*, pp. 577-598.
- Hogan, W.T.: 1984, *Steel in the United States: Restructuring to Compete*, Lexington Books, Lexington, MS/US, pp. 157.
- Hohmeyer, O., and Ottinger, R.L. (eds.): 1994, *Social Costs of Energy. Present Status and Future Trends*, Proceedings of an International Conference, Held at Racine, Wisconsin, September 8-11, 1992, Springer, Berlin/DE, pp. 436.
- Hohmeyer, O.: 1988, *Social Costs of Energy Consumption*, Springer, Berlin, 126 pp.; 1989 in German.
- Holling, C.S., Schindler, D.W., Walker, B.W., and Roughgarden, J.: 1995, 'Biodiversity in the functioning of ecosystems: an ecological synthesis', in Perrings, C. et al. (eds.) *Biodiversity Loss. Economic and Ecological Issues*, pp. 44-83.
- Holmegaard Hansen, J., and COWIconsult.: 1995, 'Nationale og industrielle emissioner af 38 stoffer. Overblikrapport', *Arbejdsrapport fra Miljøstyrelsen Nr. 64 1995*, Miljø- og Energiministeriet, Miljøstyrelsen, Copenhagen/DK, pp. 154.
- Hordijk, L.: 1991, Use of the RAINS models in acid rain negotiations in Europe, *Environmental Science Technology*, 25, pp. 596-603.
- Hovmand, M.F., Andersen, H.V., Bille-Hansen, J., Ro-Poulsen, H.: 1994a, 'Atmosfærens stoftilførsel til danske skovøkosystemer', *Faglig rapport fra DMU*, nr. 98, Danmarks Miljøundersøgelser, Roskilde/DK, pp. 59.
- Hovmand, M.F., Grundahl, L., Mancher, O.H., Egeløv, A. and Andersen, H.V.: 1994b, 'Atmosfærisk deposition på danske skove. Datarapport 1992/93', *Faglig rapport fra DMU*, nr. 122, Danmarks Miljøundersøgelser, Roskilde/DK, pp. 63.
- Hovmand, M.F.: 1990, 'Vandmiljøplanens Overvågningsprogram 1989. Atmosfæren. Nedfald af kvælstofforbindelser', *Faglig rapport fra DMU*, nr. 7, Miljøministeriet, Danmarks Miljøundersøgelser, Roskilde /DK, pp. 39.
- Hvid, E., and Jensen, S.S.: 1995, *Miljømærkning og transport*, Arbejdsrapport fra Miljøstyrelsen Nr. 9, 1995, COWIconsult, Miljøstyrelsen, København/DK, pp. 54.
- IEA: 1982, *Natural Gas. Prospects to 2000*, OECD/IEA, Paris Cedex/ FR, pp. 173.
- IEA: 1987, *Renewable sources of energy*, OECD/IEA, Paris Cedex/ FR, pp. 334.
- IEA: 1992b, *Global Energy. The Changing Outlook*, IEA, Paris Cedex/FR, pp. 204.
- IEA: 1993b, *Cars and Climate Change*, Steeg, H. (exec. director), IEA, Paris Cedex/FR, pp. 236.
- IEA: 1994a, *Natural Gas Technologies: Energy Security, Environment and Economic Development. Kyoto/JP, 31st October - 3rd November 1993. Conference Proceedings*, OECD /IEA, Paris Cedex/FR, pp.1131.
- IEA: 1994b, *Natural Gas Transportation. Organisation and Regularion*, Steeg, H. (exec. director), OECD/IEA, Paris Cedex/FR, pp. 344.
- IEA: 1994c, *Global Methane and the Coal Industry*, Steeg, H. (exec. director), OECD/IEA, Paris Cedex/FR, pp. 67.

- IEA: 1994d, *Technology Responses to Global Environmental Challenges: Energy Collaboration for the 21st Century*. Kyoto, 6th-8th November 1991, Garriba, S.F. (director), OECD/IEA, Paris Cedex/FR, pp. 971.
- IEA: 1994f, *Industrial Energy Efficiency Policies and Programmes. Conference Proceedings*. Washington, D.C., United States. 26-27 May 1994, Skinner, R.G. (director), IEA Paris Cedex/FR, pp. 335.
- IEA: 1994w, *Russian Energy Prices, Taxes and Costs 1993*, Steeg, H. (exec. director), IEA, Paris Cedex/FR, pp. 99.
- IEA: 1995, *Stockdraw and emergency response policies and management*. Kagoshima, Japan. 22-24 february 1994. *Conference Proceedings*, International Energy Agency, Government of Japan, Japan National Oil Corporation, OECD/IEA, Paris-Cedex 16/FR, pp. 316.
- IIASA: 1991, *Life-Cycle Analysis. IDEA. An International Database for Ecoprofile Analysis. A Tool for Decision Makers*, Lübker, B., Virtanen, Y., Mühlberger, M., Ingman, J., Vallance, B. and Alber, S., WP-91-30, Laxenburg/AT, pp. 174.
- IMAGE-Project: 1994, *Image 2.0: Integrated Modeling of Global Climate Change*, Alcamo, J. (ed.) with papers by the IMAGE Project, RIVM and NOP, Reprinted from *Water, Air, and Soil Pollution* 76, Nos. 1-2, 1994, pp. 318.
- Imamura, M.S., Helm, P., and Palz, W.: 1992, *Photovoltaic System Technology. A European handbook*, H S Stephens & Associates on behalf of the European Communities, Felmersham /UK, pp. 566.
- IMechE: 1994, 'Combined Heat and Power. International Conference. 11-12 October 1994, London', *IMechE 1994-8*, Mechanical Engineering Publications Limited, Bury St. Edmunds /UK, pp. 214.
- IP: 1974, *Marine Pollution by Oil, Characterization of Pollutants, Sampling, Analysis, and Interpretation*, Institute of Petroleum Oil Pollution Analysis Committee, Whitham, B.T. (chairman), Applied Science Publishers Ltd, Barking, Essex/UK, 198 pp.
- IPCC: 1995, *Climate Change 1994. Radiative Forcing of Climate Change and An Evaluation of the IPCC IS92 Emission Scenarios*, Houghton, J. T., Meira Filho, L.G., Bruce, J., Hoesung Lee, Callander, B.A., Haites, E., Harris, N. and K. Maskell (eds.), Cambridge University Press, Cambridge/UK, 339 pp.
- IPCC I: 1996, *Climate Change 1995. The Science of Climate Change*. Contribution of Working Group I to the Second Assessment Report of the Intergovernmental Panel on Climate Change, Houghton, J.T., Meira Filho, L.G., Callander, B.A., Harris, N., Kattenberg, A., and Maskell, K. (eds.), Cambridge University Press, Cambridge/UK, 572 pp.
- IPCC I: 1996a, *Climate Change 1995. The Science of Climate Change. Summary for Policymakers* (Approved by Working Group I of the IPCC and accepted by the IPCC) and *Technical Summary of the Working Group I Report* (Accepted by the IPCC), Part of the Working Group I contribution to the Second Assessment Report of the Intergovernmental Panel on Climate Change (IPCC I, 1996), WMO, Genève/CH, UNEP, Nairobi/KN, 56 pp.
- IPCC II: 1996, *Climate Change 1995. Impacts, Adaptation and mitigation of Climate Change: Scientific-technical analyses*. Contribution of Working Group II to the Second Assessment Report of the Intergovernmental Panel on Climate Change, Watson, R.T., Zinyowera, M.C., Moss, R.H., and Dokken, D.J. (eds.), Cambridge University Press, Cambridge, 878 pp.
- IPCC III: 1996, *Climate Change 1995. Economic and Social Dimensions of Climate Change*. Contribution of Working Group III to the Second Assessment Report. Bruce, J., Lee, H. and Haites, E. (eds.), Cambridge University Press, 448 pp.
- Isaksen, I.S.A., and Roland, K.: 1990, *Metanutslipp fra Naturgasskjeden. Om metan som klimagass*, NORD 1990:23, Nordisk Ministerråd, København/DK, pp. 70.
- Iyengar, V.A., and Iyengar, M.S.: 1994, 'Clean and Efficient Use of Coal with CO<sub>2</sub> Stabiliza

- Jensen, B.H.: 1983, 'En energianalyse af landbrug. økologisk contra traditionelt', *Tekster fra IMFUFA Nr. 73*, Vejleder, B. Sørensen, Roskilde Universitetscenter/DK, 97 pp.+app.
- Jensen, H.: 1993, *Sustainable Development in Transportation- preperation for the 21 century*, NORD 1993:25, Nordic Council of Ministers, København/DK, pp. 49.
- Jepsersen, J.: 1995, 'Grøn vækst, en selvmodsigtelse', *Dagbladet Information* 51, nr. 231, 4. okt. 1995, p. 10.
- Johansson, B.: 1995, 'Biomassebaserade energibärare för transportsektorn', *KFB-rapport 1995:11*, Kommunikations Forsknings Beredningen, Stockholm/SE, pp. 81.
- Johansson, P.-O.: 1993, *Cost-Benefit Analysis of Environmental Change*, Cambridge University Press, Cambridge/UK, pp. 232.
- Jørgensen, K.: 1991, *Energi, trafik og miljø - en sammenhængende teknologivurdering*, Teknologinævnets rapporter 1993/3, Teknologinævnet, København/DK, pp. 138.
- Jørgensen, P., Christensen, J.S., Vikkelsø, A., Tande, J.O., and Nørgård, P.: 1996, 'Elkvalitet ved nettilslutning af vindmøller. Del 1: Stationære Spændingsforhold', *Risø-R-853(Pt.1)(DA)*, DEFU, Lyngby/DK, Risø National Laboratory, Roskilde/DK, pp. 118.
- Kakaç, S., Paykoç, E., and Yener, Y.: 1989, 'Storage of solar thermal energy', in Kilkis and Kakac (eds.) *Energy storage systems*, Kluwer, 129-161.
- Kalkstein, L (1993). Health and climate change: direct impacts in cities. *The Lancet*, 342, 1397-1399.
- Kalkstein, L and Smoyer, K (1993). The impact of climate change on human health: some international implications. *Experientia*, 49, 969-979.
- Karl, T.R., Knight, R.W., Kukla, G., and Gavin, J.: 1995b, 'Evidence for Radiative Effects of Anthropogenic Sulfate Aerosols in the Observed Climate Record', pp. 363- 384, in Charlson, R.J., and Heintzenberg, J., 1995, *Aerosol Forcing of Climate. Report of the Dahlem Workshop on Aerosol Forcing of Climate. Berlin 1994, April 24-29*, Wiley & Sons, Chichester/UK, pp. 416.
- Katic, I, Sørensen, B, and Windeleff, J: 1995, Danish national photovoltaic programme, pp. 2302-2305 in *Proc. First World Conference on Photovoltaic Energy Conversion*, IEEE, New Jersey.
- Kehrbaum, R.: 1996, Disposal of wind turbines: technical, economic and environmental considerations, pp. 177-180 in *1996 European Union Wind Energy Conference*, Stephens & Assoc., Bedford.
- Keiderling, S.: 1990, 'Simulation und Optimierung von kombinierten Wind- und Solaranlagen zur Stromversorgung', *Fortschritt-Berichte VDI Reihe 6: Energieerzeugung Nr. 246*, VDI-Verlag, Düsseldorf/DE, pp. 183.
- Kemp, K., Palmgren, F., and Manscher, O.H.: 1994, 'Danish Air Quality Monitoring Program. Annual Data Report 1993', *NERI Technical Report No. 113*, National Environmental Research Institute, Risø/DKpp. 79.
- Kendrick, D.A., Meeraus, A., and Alatorre, J. (eds.): 1984, *The Planning of Investment Programs in the Steel Industry*, The John Hopkins University Press, Baltimore/US and London/UK, pp. 310.
- Keoleian, G. and Menerey, D.: 1993, 'Life Cycle Design Guidance Manual. Environmental Requirements and The Product System', *EPA/600/R-92/226*, U.S. Environmental Protection Agency, Cincinnati/US, pp. 181.
- Kilkis, B., and Kakac, S. (eds.): 1989, *Energy Storage Systems*, Kluwer Academic Publishers, Dordrecht/NL, pp. 746.
- Kobayasi, S.: 1994, 'In Harmony with the Global Environment — Development of Integrated Gasification Combined Cycle', in IEA 1994d, pp. 306-14.
- Krane, R.J.: 1989, 'Second law optimization of thermal energy storage systems: latent heat systems', in Kilkis and Kakac (eds.) *Energy storage systems*, Kluwer, 69-88.
- Kuemmel, B.: 1996b, 'Calculating Fuel Import Emissions', *Tekster fra IMFUFA nr. 328*, Roskilde University, Roskilde/DK, pp. 25.

- Kågeson, P.: 1993, *Getting the prices right: A European scheme for making transport pay its true costs*. European Federation for Transport and Environment, Stockholm.
- Lama, R.D. 1992: 'Methane gas emission from coal mining in Australia: Estimates and control strategies', in *IEA 1992a*, 255-266.
- Latta, A.F., Bowyer, J.M., Fujita, T., and Richter, R.H.: 1979 'The Effects of Regional Insolation Differences Upon Advanced Solar Thermal Electric Power Plant Performance and Energy Costs', *DOE/JPL-1060-17*, U.S. Department of Energy, Washington D.C./US, Jet Propulsion Laboratory, Pasadena/US, *JPL Publication 79-39*, pp. 24+85 (app.).
- Lauenroth, W.K., and Preston, E.M.(eds.): 1984, *The Effects of SO<sub>2</sub> on a Grassland. A Case Study in the Northern Great Plains of the United States*, Ecological Studies 45, Springer, New York, pp. 207.
- Lawaetz, H.: 1993, *Sæsonvarmelagring i store ståltanke*, Prøvestationen for Solenergi, DTI, Taastrup/DK, pp. 13 + appendix.
- Lawrence, G.B., David, M.B., and Shortle, W.C.: 1995, 'A new mechanism for calcium loss in forest-floor soils', *Nature* **378**, 162-165.
- Levine, R.M.: 1988, *The Mineral Industries of The U.S.S.R. 1988 International Review*, U.S. Department of the Interior, Bureau of Mines, Washington/US, pp. 30.
- Libicki, J.: 1993, 'The Impact of Lignite Surface Mining on the Environment in Poland: Facts and Social Perception', in *IEA 1993a*, pp. 577-584.
- Lownie Jr, H.W.: 1973, 'Potential for energy conservation in the steel industry', in Szekely, J. (ed.) *Alternative Energy Sources for the Steel Industry*, Marcel Dekker, Inc, New York/US and Basel/CH, pp. 119, 99-105.
- LTI project group: 1996, *Long Term Integration of Renewables into the European Energy System Project*, EC project RENA-CT94-0041, ZEW, Mannheim, 451 pp.
- Lübker, B., Virtanen, Y., Mühlberger, M., Ingman, J., Vallance, B. and Alber, S.: 1991, *Life-Cycle Analysis. IDEA. An International Database for Ecoprofile Analysis. A Tool for Decision Makers*, WP-91-30, Laxenburg/AT, pp. 174.
- Lyman, W.J., Noonan, D.C., and Reidy, P.J.: 1990, 'Cleanup of Petroleum Contaminated Soils at Underground Storage', *Pollution Technology Review No. 195*, Noyes Data Corporation, Park Ridge/US, pp. 216.
- Lövblad, G., Erisman, J.W., and Fowler, D.: 1993, *Models and Methods for the Quantification of Atmospheric Input to Ecosystems*, Nordiske Seminar- og Arbejdsrapporter, NORD 1993:573, Nordic Council of Ministers, Copenhagen /DK, pp. 221.
- Makrogiannis, T.J., Sahsamanoglou, H.S., Flocas, A.A., and Bloutsos, A.A.: 1991, 'Analysis of the monthly zonal index values and long-term changes of circulation over the North Atlantic and Europe', *Int. J. Climatol.* **11** (5), 493-503.
- Manne, A.S., and Richels, R.G.: 1992, *Buying Greenhouse Insurance: The Economic Costs of Carbon Dioxide Emission Limits*, The MIT Press, Cambridge, MS/US, pp. 182.
- Marfelt, B.: 1995, 'Trafikken trækker hårdt på kreditten', *Ingeniøren* **21**, 1. sektion, p. 6.
- Martens, W., Rotmans, J, Niessen, L (1994). *Climate change and malaria risk*. GLOBO Report 3-461502003. Global Dynamics & Sustainable Development Programme, RIVM, Bilthoven, NL.
- Masood, E.: 1996b, 'Once upon a smoggy day in London town...', *Nature* **381**, 181.
- McKinney, M.L., and Schoch, R.K.: 1996, *Environmental Science. Systems and solutions*, West Publishing Company, Minneapolis/St. Paul/US, pp. 888.
- Meibom, P, Svendsen, T. and Sørensen, B.: 1997, *Import/export policy as a tool for optimising the utilisation of electricity produced using renewable energy*. (report in progress).
- Meyer, A.: 1995, 'Economics of Climate Change', *Nature* **378**, 433.

- Meyer, H., Morthorst, P.E., Schleisner, L., Meyer, N.I., Nielsen, P.S. and Nielsen, V.: 1994, 'Om-kostningsopgørelse for miljøksternaliteter i forbindelse med energiproduktion', *Risø-R-770(DA)*, Forskningscenter Risø, Roskilde/DK, 180 pp.
- Mez, L., Jänicke, M., Pöschk, J., and Wanke, A.: 1990, *Zur Energiesituation in der vormaligen DDR. Darstellung, Kritik und Perspektiven der Elektrizitätsversorgung. Erweitertes und aktualisiertes Gutachten im Auftrag der Partei Die GRÜNEN, Fraktion Die GRÜNEN im Bundestag und Fraktion der Alternativen Liste Berlin*, FU Berlin, Fachbereich Politische Wissenschaft, Berlin/DE, pp. 231.
- Michalski, B., Antonides, L.E., and Morgan, G.A.: 1988, *The Mineral Industries of The Arabian Peninsula and Persian Gulf Countries. 1988 International Review*, U.S. Department of the Interior, Bureau of Mines, Washington/US, pp. 36.
- Miettinen, I.T., Vartiainen, T., and Martikainen, P.J.: 1996, 'Contamination of drinking water', *Nature* **381**, 654-655.
- Mills, D (1995). A climate water budget approach to blackfly population dynamics. *Publications in Climatology*, **48**, 1-84
- Mittermaier, R.A.: 1988, 'Primate diversity and the tropical forest. Case studies from Brazil and Madagascar and the importance of the megadiversity countries', in Wilson, E.O., and Peter, F.M. (eds.), *Biodiversity*, 145-154.
- Mooney, H.A.: 1988, 'Lessons from Mediterranean-climate regions' in Wilson, E.O., and Peter, F.M. (eds.), *Biodiversity*, 157-165.
- Morthorst, P.E., Nielsen, L.H., and Schleisner, L.: 1993, 'Hydrogen as an energy carrier', *Risø-R-694(EN)*, Risø National Laboratory, Roskilde/DK, pp. 40.
- Mrasek, V.: 1996, 'Experimente im gläsernen Motor. Wie sich Schadstoff-Emissionen bereits an der Quelle verringern lassen', *Süddeutsche Zeitung*, 11. april 1996.
- Müller, M., and Gregersen, J.C.: 1995, 'Ståls livscyklus i forskellige anvendelsessituationer', *Arbejdsrapport fra Miljøstyrelsen Nr. 14*, 1995, Miljøstyrelsen, København/DK, pp. 106.
- Møller Andersen, F., Kilde, N.A., Nielsen, L.H., and Præstegaard, S.: 1991, 'En teknisk-økonomisk prognosemodel for industriens energiforbrug samt energirelaterede CO<sub>2</sub>- SO<sub>2</sub>- og NO<sub>x</sub>-emissioner. INDUS - version 2 EMIS', *Risø-M-2920*, Risø National Laboratory, Roskilde/DK, pp. 157.
- Møller-Holst, G., Johannessen, M., Nielsen, B., and Sørensen, B.: 1995, 'TOK. Modellering af træers vækst under påvirkning af ozon', Vejleder J. Larsen, *Tekster fra IMFUFA Nr. 301*, Roskilde Universitetscenter/DK, pp. 186.
- Nagato, S., Miyoshi, N., Satoh, Y., Toyoda, S., Ohshita, T.: 1993, 'Research into a Low-Polluting, Compact, High-Efficiency, Internally Circulating Fluidized Bed Boiler, Capable of Handling Different Coals', in *IEA 1993a*, pp. 691-697.
- National Swedish Board for Energy Source Development: 1983, *The status of forest energy plantation mechanization*, K.C. Jones & Associates (eds.), NE 1983:4, Stockholm, 49 pp.+ app.
- Neumann, H.-J., Paczynska-Lahme, B. and Severin, D.: 1981, 'Composition and Properties of Petroleum', *Geology of Petroleum Vol. 5*, Beckmann, H. (ed.), Ferdinand Enke Verlag, Stuttgart/DE, pp. 137.
- Nielsen, J.S.: 1994, 'Noget er ved at ske – måske...', *Dagbladet Information* **50**, nr. 305, 31. dec. 1994 - 1. jan. 1995, pp. 10-11.
- Nielsen, L.H.: 1994, 'Vedvarende energi i stor skala til el- og varmeproduktion. Indpasning i elsystemet af vedvarende energi i stor skala i en usikker fremtid', *Risø-R-784(DA)*, Hovedrapport, Forskningscenter Risø, Roskilde/DK, ELKRAFT, Ballerup/DK, ELSAM, Fredericia /DK, pp. 114.
- Nielsen, P.S., and Holm-Nielsen, J.B.: 1996, 'CO<sub>2</sub> balance in production of energy based on biogas', poster presented at the European conference: *Environmental Impact of Biomass for Energy*, 4-5 November 1996, Nordwijkerhout/NL.

- Nielsen, S.K., and Sørensen, B.: 1996, 'The Fair Market Scenario', *Long term integration of renewable energy sources into the european energy system, and its potential economic and environmental impacts*, Final report of EC APAS/RENA project CT94-0041, 30. june 1996, Energy & Environment Group, IMFUFA, Roskilde University, 128 pp.
- Nielsen, S.K., and Sørensen, B.: 1997, 'Long-term planning for energy efficiency and renewable energy', in *Proceedings of renewable energy conference, Cairo, April 1996*, forthcoming.
- Nisbet, E.G., and Ingham, B.: 1995, 'Methane Output from Natural and Quasinatural Sources: A review of the Potential for Change and for Biotic and Abiotic Feedbacks', in *Woodwell and Mackenzie, 1995*, pp. 188-218.
- NOH: 1992, *Environmental life cycle assessment of products. Guide-October 1992*, Heijungs, R. (final ed.), Guinée, J.B., Huppes, G., Lankreijer, R.M., Haes, H.A. Udo de, Wegener Sleewijk, A., Ansems, A.M.M., Eggels, P.G., Duin, R. van, and Goede, H.P. de, Centrum coor Milieukunde, Leiden/NL, pp. 96.
- Nonhebel, I.S.: 1994, 'Comment on "Biomass energy options in Western Europe (OECD) to 2050"', in OECD 1994a, *Energy technologies to reduce CO<sub>2</sub> emissions in Europe*, 195-197.
- Nonhebel, I.S.: 1995, *Harvesting the sun's energy using agro-ecosystems*, Report NOP-MLK, project 853117, Vakgroep Theoretische Productie Ecologie, Wageningen/NL, pp. 57 + 1.
- Norby, R.J.: 1996, 'Forest canopy productivity index', *Nature* **381**, 564.
- NORD: 1986, 'Critical Loads for Sulphur and Nitrogen, Report from a Nordic working group', Nilsson, J. (ed.), Andersen, B., Dickson, W., Eriksson, E., Henriksen, A., Kämäri, J., Nilsson, I. and Nilsson, J., *NORD 1986:11*, Nordiska Ministerrådet, København/DK, pp. 232.
- NORD: 1987, 'Atmospheric Chemistry, Transport and Deposition of Nitrogen Oxides. Status report prepared for the working group on nitrogen oxides within ECE's Convention On Long-Range Tranboundary Air Pollution, Grennfelt, P. (ed.), Eliassen, A., Hov, Ø., Berkowicz, R. and Nordlund, G., *NORD 1987:1*, Nordisk Ministerråd, København/DK, pp. 89.
- NORD: 1989, 'Energi och Miljö i Norden. På väg mot en bärkraftig utveckling?', Magnussen, J., *NORD: 56*, Nordiska Ministerrådet, København/DK, pp. 159.
- NORD: 1990, 'Typiske Utslippsgrænse til luft i Danmark, Finland, Norge og Sverige', Thomsen, E., Abrahamson, U., Hietamäki, M. and Borgström, B., *NORD 1990:41, Miljørapport 1990:7* Nordiska Ministerrådet, København/DK, pp. 159.
- NORD: 1992, 'Product Life Cycle Assessment - Principles and Methodology', *NORD 1992:9*, Nordic Council of Ministers, Copenhagen/DK, pp. 288.
- NORD: 1993, 'Transport og miljø - nordiske data', *NORD 1993:620*, Nordisk Seminar-og Arbejdsrapport, Nordisk Ministerråd, København/DK, pp. 24.
- Nordhaus, W. 1990. *To slow or not to slow: the Economics of the Greenhouse Effect*. Yale Univ.
- Nordhaus, W.D.: 1994, *Managing the Global Commons: the economics of climate change*, MIT Press, Massachusetts/US, pp. 213.
- Nordström, R., and Henriksson, A.: 1991, *Unit Loads. Arguments and Preconditions for the Choice of Dimensions*, TFB-Report 1991:20, Swedish Transport Reserach Board, Stockholm/SE, pp. 40.
- NRC: 1993, 'Environmental Information for Outer Continental Shelf Oil and Gas Decisions', Committee to Review Alaskan Outer Continental Shelf Environmental Information, Groat, C.G. (chair), Board on Environmental Studies and Toxicology, Risser, P.G. (chair), Board on Earth Sciences and Resources, Fisher, W.L. (chair), Commission on Geosciences, Resources and the Environment, Wolman, M.G. (chair), National Research Council 1994, National Academy Press, Washington/US, pp. 254.
- OECD: 1988, *Environmental Impacts of Renewable Energy. The OECD Compass Project*, OECD, Paris/FR, pp. 93.



- OECD: 1989, *Renewable Natural Resources. Economic Incentives for improved Management*, reprinted, 1991, OECD, Paris/FR, pp. 157.
- OECD: 1989a, *The Role of Technology in Iron and Steel Developments*, OECD, Paris Cedex 16/FR, pp. 69.
- OECD: 1991, *Responding to Climate Change: Selected Economic Issues*, OECD, Paris Cedex/FR, pp. 149.
- OECD: 1993, *Expert Workshop on Life-Cycle Analysis of Energy Systems, Methods and Experiences. Proceedings. Paris, France, 21st-22nd May 1992*, S.F. Garriba and B.L. Long (directors), OECD/IEA, Paris Cedex 16/FR, pp. 359.
- OECD: 1994, *The Economics of Climate Change. Proceedings of an OECD/IEA Conference*, OECD, Paris Cedex/FR, pp. 155.
- OECD: 1994a, *Energy Technologies to reduce CO<sub>2</sub> emissions in Europe: Prospects, competition, synergy. Petten, The Netherlands. 11-12 april 1994. Conference Proceedings*, International Energy Agency, Netherlands Ministry of Economic Affairs, Netherlands National Research Programme on Global Air Pollution and Climate Change, Netherlands Energy Research Foundation, European Commission Research Directorate (DG XII), International Panel on Climate Change Mitigation Options Working Group, OECD/IEA, Paris-Cedex 16/FR, pp. 328.
- OECD: 1995, *Global Warming. Economic Dimensions and Policy Responses*, OECD, Paris Cedex 16/FR, pp. 155.
- Okken, P.A., Swart, R.J., and Zwerver, S. (eds.): 1989, *Climate and Energy. The feasibility of controlling CO<sub>2</sub> emissions*, Kluwer Academic Publishers, Dordrecht/NL, pp. 267.
- ORNL and RFTF: 1992, *Damages and benefits of the hydroelectric fuel cycle: estimation methods, impacts, and values. Draft. Prepared for the U.S. Department of Energy and the Commission of the European Communities. Revision 1; 30. dec. 1992*, Oak Ridge National Laboratory and Resources for the Future, pp. c. 200.
- ORNL and RFTF: 1992a, *Damages and benefits of the coal fuel cycle: estimation methods, impacts, and values. Draft. Prepared for the U.S. Department of Energy and the European Commission. August 1992*, Oak Ridge National Laboratory and Resources for the Future, pp. c. 500.
- ORNL and RFTF: 1992b, *Damages and benefits of the biomass-to-electricity fuel cycle: estimation methods, impacts, and values. Draft. Prepared for the U.S. Department of Energy and the European Commission. August 1992*, Oak Ridge National Laboratory and Resources for the Future, pp. c. 500.
- Oss, H.G. van, and Michalski, B.: 1988, *The Mineral Industries of West Africa. 1988 International Review*, U.S. Department of the Interior, Bureau of Mines, Washington/US, pp. 33.
- Ottinger, R. (ed.), 1990. *Environmental costs of electricity*, Pace University.
- Palz, W., Chartier, P. and Hall, D.O. (eds.): 1981, *Energy from Biomass. 1st E.C. Conference*, Applied Science Publishers Ltd, London/UK, pp. 982.
- Parry, M and Rosenzweig, C (1993). Food supply and the risk of hunger. *The Lancet*, **342**, 1345-7
- Patterson, W.C.: 1987, *Advanced Coal-Use Technology*, FT Business Information Ltd, London/UK, pp. 124.
- Patterson, W.: 1994, *Power from Plants. The global implication of new technologies for electricity from biomass*, Earthscan, London/UK, pp. 102.
- Peake, S: 1994, *Transport in transition. Lessons from the history of energy. The Royal Institute of International Affairs. Energy and Environmental Programme*, Earthscan Publications Ltd, London/UK, pp. 113.
- Pearce, D., and Moran, D.: 1994, *The Economic Value of Biodiversity*, IUCN, The World Conservation Union, Earthscan Publications Limited, London/UK, pp. 172.
- Pearce, D., and Puroshothaman, S.: 1995, 'The economic value of plant-based pharmaceuticals', in Swanson, T. (ed.), *Intellectual property rights and biodiversity conservation*, pp. 127-138.

- Pearce, D.W., and Nash, C.A.: 1981, *The social appraisal of projects. A text in cost-benefit analysis*, MacMillan Press Ltd., London and Basingstoke/UK, pp. 225.
- Pedersen, S.L.: 1981, *En Analyse af det Danske Energisystem*, Master's Thesis, Niels Bohr Institutet, København/DK, cols. 131.
- Petersen, I.K.: 1995, 'Vandfugles antal og fordeling i Det Sydfynske Øhav og Helnæs Bugt 1991-1992. Et samarbejdsprojekt mellem Skov- og Naturstyrelsen, Fyns Amt og DMU', *Faglig rapport fra DMU, nr. 130*, Danmarks Miljøundersøgelser, Roskilde/DK, pp. 63.
- Petäjä, J.: 1992, 'Probabilistic Production Cost Simulation of the Nordic Electricity Scenarios', *NORD 1992: 551*, Nordisk Ministerråd, København/DK, pp. 14.
- Phylipsen, G.J.M., and Alsem, E.A.: 1995, 'Environmental life-cycle assessment of multicrystalline silicon solar cell modules', *Report no. 95057*, Vakgrope Natuurwetenschap en samenleving, Universiteit Utrecht/NL, pp. 65.
- Pickel, M.B. (ed.): 1983, *Pipelines In Adverse Environments II. Proceedings of the Conference on Pipelines In Adverse Environments II*, American Society of Civil Engineers, New York/US, pp. 740.
- Plotkin, K.J.: 1988, 'The Outlook for New Agricultural and Industrial Products from the Tropics', in Wilson and Peter (eds.) *Biodiversity*, 106-116.
- Poulsen, M.E., Grundahl, L., and Palmgren, F.: 1995, 'Atmospheric PAH in Denmark', *NERI Technical Report No. 124*, Ministry of Environment and Energy, Copenhagen/DK, National Environmental Research Institute, Risø/DK, pp. 73.
- Prather, M., Bidgley, P., Sherwood Rowland, F., Stolarski, R.: 1996, 'The ozone layer: the road not taken', *Nature* **381**, 551-554.
- Priemé, A. and Christensen, S.: 1991a, 'Emission of Nitrous Oxide in Denmark. Natural and Agricultural related Sources', *NERI Technical Report No. 18*, National Environmental Research Institute, Risø/DK, pp. 45.
- Priemé, A. and Christensen, S.: 1991b, 'Emission of methane and nonmethane volatile organic compounds in Denmark. Sources related to Agriculture and natural ecosystems', *NERI Technical Report No. 19*, National Environmental Research Institute, Risø/DK, pp. 74.
- Radgen, P., and Tönsing, E.: 1995, *Energieeinsparmöglichkeiten im Industriebereich in Europa bis zum Jahr 2050. Untersuchungen für das Zentrum für Europäische Wirtschaftsforschung (ZEW), Mannheim. Endbericht*, Fraunhofer-Institut für Systemtechnik und Innovationsforschung (ISI), Karlsruhe/DE, pp. 79.
- Rasmussen, L.: 1988, *Sur Nedbørs Effekt på Ionbalancen og Udvaskningen af Metaller og Anioner i Danske Nåleskovøkosystemer i Perioden 1983-1987*, Laboratoriet for økologi og miljølære, DTU, Lyngby, EM-Journal nr.: 1323/86-16, pp. 74.
- Rasmussen, T., Makies, A., and Ohde, J.: 1991, *Umweltverschmutzungsbedingte Einkommensverluste der Fischwirtschaft in der Bundesrepublik Deutschland*, Umweltbundesamt, Berlin/DE, pp. 449.
- Rastogi, S.C. and Jensen, G.H.: 1995, 'Analytisk-kemisk kontrol af kemiske stoffer og produkter. Undersøgelse af 1,1,1-trichlorethan i lim og slipmidler', *Faglig rapport fra DMU, nr. 128*, Danmarks Miljøundersøgelser, Roskilde/DK, pp. 27.
- Rawson, K.: 1994, *The Carriage of Bulk Oil and Chemicals at Sea*, Institution of Chemical Engineers, Rugby/UK, pp. 105.
- Reichhardt, T.: 1996, 'Quantifying risk can be easier said than done', *Nature* **380**, 12.
- Reid, W.V., and Miller, K.R.: 1989, *Keeping options alive: The scientific basis for conserving biodiversity*, World Resources Institute Report, Washington/US, pp. 128.
- Rexen, F.P.: 1981, 'Straw and animal residues available for energy', in Palz et al., *Energy from biomass*, 50-58.
- Rosa, L.P., and Schaeffer, R.: 1994, 'Greenhouse emissions from hydroelectric reservoirs', *Ambio* **23**, 164-165.

- Rosenzweig, C., Parry, M., Fischer, G., Froberg, K. (1993). *Climate change and world food supply*. Report 3, Environmental Change Unit, Oxford University, UK
- Royal Society: 1977, *Long-term hazards from environmental chemicals. A Royal Society Discussion. Organized by Sir Richard Doll, F.R.S., and A.E.M. Mclean for the Royal Society's study group on long-term toxic effects. Held on 13 and 14 december 1977*, The Royal Society, London/UK, pp. 197.
- Rudd, J.W.M., Reed, H., Kelly, C.A., and Hecky, R.E.: 1993, 'Are hydroelectric reservoirs significant sources of greenhouse gases?', *Ambio* 22, 246-248.
- Runge, E.H., Asman, W.A.H. and Kilde, N.A.: 1991, 'A detailed Emission Inventory of Nitrogen Oxides for Denmark', *RISØ-M-2929*, DMU, Risø Library, Risø/DK, pp. 68.
- Runge, E.H., Asman, W.A.H. and Kilde, N.A.: 1992, 'A detailed Emission Inventory of SO<sub>2</sub> for Denmark', *NERI Technical Report No. 45*, National Environmental Research Institute, Risø /DK, pp. 38.
- Rybner, K., and Folmer Hansen, P.: 1995, 'Quality control of crude oil and product stocks. Some technical considerations. The solution of product obsolescence problem in Denmark', in *IEA 1995*, 89-92.
- Rybner, K.: 1995, 'Structure of emergency stocks. Balance between emergency stocks of individual products: A case study of Denmark', in *IEA 1995*, 51-55.
- Saatgut: 1996, *saatgut. Dokumentation zur Ausstellung Forschung und Züchtung in der biologisch-dynamischen Landwirtschaft. Dokumentation zur Ausstellung*, Beringer, E., and Heyden, B. (eds.), J. u. C. Graf Keyserlingk-Institut, Salem, pp. 30.
- Sander Nielsen, B., Espersen, S., Holm-Nielsen, J.B., Ravnsbæk, P., Parsby, M., and Boldt, J.: 1994, *Biomasse til energiformål - et strategisk oplæg*, Teknologinævnets rapporter 1994/4, Teknologinævnet, København/DK, pp. 115.
- Santer, B.D., Taylor, K.E., Wigley, T.M.L., Johns, T.C., Jones, P.D., Karoly, D.J., Mitchell, J.F.B., Oort, A.H., Penner, J.E., Ramaswamy, V., Schwarzkopf, M.D., Stouffer, R.J., and Tett, S.F.B.: 1996, 'A search for human influences on the thermal structure of the atmosphere', *Nature* 382, 39-46.
- Schauer, T., and Caspari, C.: 1993, *Der große BLV Pflanzenführer. Über 1500 Blütenpflanzen Deutschlands und der Nachbarländer*, BLV, München/DE, pp. 463.
- Schliephake, K.: 1977, *Oil and Regional Development. Examples from Algeria and Tunisia. Praeger Special Studies in International Economics and Development*, Praeger, New York/US, pp. 203.
- Schmidt, A., Christiansen, K., and Pommer, K.: 1994, *Livscyklusmodel til vurdering af nye materialer - Metoder, vurdering og fremgangsmåde*, dk-TEKNIK, Søborg/DK, 148+54 pp.
- Schmidt, A., Drabæk, I., and Christiansen, K.: 1994, *Livscyklusmodel til vurdering af nye materialer - Baggrund, principper og anvendelse*, dk-TEKNIK, Søborg/DK, 33 pp.
- Schneider, M., Berger, X., Bourdeau, L., Jaffrin, A., and Sylvain, J.D.: 1977 'Conception de chauffage solaire en domaine mediterraneen', Journées Internationales d'Etude "Le Chauffage Solaire dans L'habitat", Liège, 12-14 Septembre 1977, Observatoire de Nice, Nice Cedex/FR, 20 pp.
- Seip, H.M., Andersen, B., Andersson, G., Hov, Ø., Kucera, V., Lessmark, O. and Moseholm, L.: 1987, 'Acid Precipitation, Literature Review', *NORD 1987:48, Miljørapport 1987:5*, Nordisk Ministerråd, København/DK, pp. 215.
- Selvig, E., and Hov, Ø.: 1991, 'Miljö och energi i Norden - energiscenarier för år 2010, Bilag 1', *NORD 1992:549*, Nordisk Ministerråd, København/DK, pp. 41.
- Sens, P.F., McMullan, J.T., and Williams, B.C.: 1994, 'Prospects for Zero Emission Coal Fired Power Plants', in *IEA 1994d*, pp. 271-297.
- Shen, S.: 1988, 'Biological engineering for sustainable biomass production', in Wilson and Peter (eds.) *Biodiversity*, 377-389.
- Simeons, C.: 1978, *Coal. Its Role in Tomorrow's Technology. A Sourcebook on Global Coal Reserves*, Pergamon Press, Oxford/UK, pp. 313.

- Skov, H., Hovmand, M.F., Grundahl, L., Runge, E.H., Kemp, K., Austrup, W. and Heidam, N.Z.: 1994, 'Atmosfærisk deposition af kvælstof', Vandmiljøplanens Overvågningsprogram 1993, *Faglig rapport fra DMU, nr. 123*, Danmarks Miljøundersøgelser, Roskilde/DK, pp. 61.
- Skowrya, R.: 1994, 'Design Considerations for Utility Size CFB Steam Generators', in *IEA 1994e*, pp. 957-970.
- Smith, I.M. and Thambimuthu, K.V.: 1991, 'Greenhouse gases, abatement and control: the role of coal', IEA Coal Research, London/UK, pp. 88.
- Spoelstra, R.W., Schreurs, H.C.E., and Tummers, P.J.: 1993, 'Technologies for Waste Management and Utilization: State-of-the-Art of Coal Combustion Residues Applications', in *IEA 1993a*, pp. 207-230.
- Starr, C.: 1976, 'General Philosophy of Risk-Benefit Analysis', in Ashley *et al.* (1976), *Energy and the Environment*, 1-30.
- Statistisches Bundesamt: 1996, *Statistisches Jahrbuch 1996*, Bundesamt für Statistik, Wiesbaden/DE.
- Stimming, U., Biedermann, P., and Fedders M.: 1992, 'Perspektiven und Technik der Brennstoffzelle', in *VDI 1992*, 203-221.
- Stjernquist, I.: 1986, 'Miljøkonsekvenser av Energiformer Baserade på förnubara Energikällor', *NORD 1986:5*, nordisk ministerråd, København/DK, pp. 264.
- Storr-Hansen, E. and Wrang, P.: 1990, 'Læsø-Projektet. Nedbrydningsstudier af ilanddrevet olie. Kemiske analyser', *Faglig rapport fra DMU, nr. 13*, Danmarks Miljøundersøgelser, Roskilde/DK, pp. 29.
- Stratmann, E., Teubner, L., Busch, M., and Damm, W. (eds.): 1989, *Das grüne Energiewende-Szenario 2010. Sonne. Wind und Wasser*, elaborated of: Fritsche, U., Kohler, S., Viefhues, D., Leprich, U., 2. Korrig. u. erw. Auflage, 1991, Kölner Volksblatt Verlag, Köln/DE, pp. 273.
- Styhr Petersen, H.J., and Rømer, H.G.: 1994, 'Skibs- og rørtransport af farligt gods i Danmark', *Notat 94-03*, Transportrådet, København/DK, pp. 48+appendix.
- Svensson, T.: 1990, *Miljøkonsekvenser Av Ny Energiteknik. Solvärme, Värmelager, Värmepumper*, Byggeforskningsrådet, Stockholm/SE, pp. 82.
- Swanson, Pearce, D., and Cervigni, R.: 1994, *The Appropriation of Plant Genetic Resources for Agriculture: an Economic Analysis of the Alternative Mechanisms for Biodiversity Conservation*. Commission on Plant Genetic Resources, Background Study, Paper no. 1, FAO, Rome
- Swanson, T.: 1994b, 'The nature of the Global Biodiversity Problem in Relation to PGRFA', in Swanson, Pearce, and Cervigni
- SZ-stw: 1996, 'Bahn, Lkw und Billig-Anbieter zehren die Binnenschiffer aus. Flotte schrumpft rasant. Kritik an Dumpingpreisen der Bahn. Hilfsprogramme ein Flop', *Süddeutsche Zeitung* (179), 5. august 1996, p. 17.
- Søndergaard, L., and Bindner, H.: 1995, 'Undersøgelse af generatorkoncepter til vindmøller - Direkte drevet generator til gearløs vindmølle', *Risø-R-801*, Risø National Laboratory, Roskilde, pp. 52.
- Sørensen, B.: 1975, Energy and resources, *Science* **189**, pp. 255-260
- Sørensen, B.: 1979, *Renewable Energy*, Energy Science and Engineering: Resources, Technology, Management. An International Series, Denton, J. (ed.), Academic Press, London/UK, pp. 683.
- Sørensen, B.: 1981, Renewable energy planning for Denmark and other countries, *Energy*, **5**, pp. 293-303
- Sørensen, B.: 1981b, Wind energy, pp. 97-116 in *Renewable energy sources and the environment* (E. El-Hinnawi and A. Biswas, eds.), Tycooli Int. Press, Dublin.
- Sørensen, B.: 1982, Comparative risk assessment of total energy systems, in *Health Impacts of different sources of energy*, IAEA Publ. SM-254/105, Vienna, pp. 455-471
- Sørensen, B.: 1989, *Blegdamsvej 17* (in Danish). Munksgård, Copenhagen.

- Sørensen, B.: 1991, Energy conservation and efficiency measures in other countries. *Greenhouse Studies No. 8*. Australian Department of the Arts, Sport, the Environment, Tourism and Territories, Canberra, 118 pp.
- Sørensen, B.: 1992, The impact of energy efficiency on renewable energy options. *Renewable Energy Technology and the Environment* (A. Sayigh, ed.), Pergamon Press, London, pp. 2654-2664.
- Sørensen, B.: 1993, 'What is Life-Cycle-Analysis?', in *Life-Cycle Analysis of Energy Systems*, Expert Workshop Proceedings, OECD Publications, Paris, pp. 21-53.
- Sørensen, B.: 1993a, 'Fotovoltaisk Statusnotat 2', *Tekster fra IMFUFA* Nr. 264, Roskilde Universitetscenter, 94 pp.
- Sørensen, B.: 1995, Strategy for a rich, fulfilling and sustainable society, in *Expanding environmental perspectives* (Lundgren, Nilsson and Schlyter, eds.), pp. 83-101; also *Int. Journal of Solar Energy*, 17, pp. 83-100
- Sørensen, B.: 1995a, *Tekster fra IMFUFA* Nr. 300, Roskilde Universitetscenter, see 1996e.
- Sørensen, B.: 1995b, '1st Annual report from the project Life-cycle analysis of the total danish energy system. An example of using methods developed for the OECD/IEA and the US/EC fuel cycle externality study', *Tekster fra IMFUFA* Nr. 291, Roskilde Universitetscenter, 90 pp.
- Sørensen, B.: 1995c, 'Aggregation and Life-Cycle Extension of Externality Studies, Final Report within the Joule Programme ExternE-Project', Roskilde University, Institute 2, Roskilde, 51 pp.
- Sørensen, B.: 1995d, Life-cycle approach to assessing environmental and social costs of photovoltaics, *Applied Energy* 52 (supp.), 357-374.
- Sørensen, B.: 1995e, Life-cycle analysis, pp. 413-415 in *Conservation and environmentalism - an encyclopedia*, Garland Publishers, New York.
- Sørensen, B.: 1995f, History of, and recent progress in, wind energy utilisation, *Annual Review of Energy and the Environment*, 20, pp. 387-424.
- Sørensen, B.: 1996, 'Life-cycle approach to assessing environmental and social costs', in *Comparing energy technologies*, OECD/IEA, Paris, pp. 197-231
- Sørensen, B.: 1996a, Externality estimation of greenhouse warming impacts, *Tekster fra IMFUFA*, Nr. 319, Roskilde Universitetscenter, 6 pp.; *Energy Conversion and Management* (forthcoming)
- Sørensen, B.: 1996b, Technical consistency of scenarios, Contribution to Final report of EC APAS/RENA project CT94-0041, 30. june 1996, NOVATOR, Allerød, 33 pp.
- Sørensen, B.: 1996c, 'Environmental and health impacts of energy production and use', in Diesendorf and Hamilton (eds.), *Towards an ecologically sustainable society*, forthcoming, Allen and Unwin, 14 pp.
- Sørensen, B.: 1996d, The role of life-cycle analysis in risk assessment, *Int. Journal of Environment and Pollution*, 6, pp. 729-746.
- Sørensen, B.: 1996e, 'Scenarios for greenhouse warming mitigation', *Energy Conservation and Management*, 37, 693-698.
- Sørensen, B.: 1997, Non-linear modelling of integrated energy supply and demand matching systems, *Tekster fra IMFUFA*, Nr. 327, Roskilde Universitetscenter, 12 pp.; *Journal of Global Energy Issues*, (forthcoming)
- Sørensen, B. and Watt, M.: 1993, Life cycle analysis in the energy field, *Proc. 5<sup>th</sup> International Energy Conference "Energex '93"*, 6, pp. 66-80, Korea Inst. of Energy Research, Seoul.
- Sørensen, B., Henrik Nielsen, L., Lauge Pedersen, S., Illum, K., and Mortholst, P.E.: 1994, *Fremtidens vedvarende energisystem - et lysegrønt og et mørkegrønt scenarie*, Teknologinævnets rapporter 1994/3, Teknologinævnet, København, pp. 1-68.
- Tafdrup, S.: 1993, *Environmental impact of biogas production from Danish centralized plants*, presentation at the IEA Bioenergy Environmental Impact Seminar, September 20-21, 1993, Elsinore/DK.

- Tamburrano, F.: 1995, 'Quality control of crude oil and product stocks. Issues resulting from deterioration of oil products in long term storage', in *IEA 1995*, 93-98.
- Tande, J.O., Nørgård, P., Sørensen, P., Søndergård, L., Jørgensen, P., Vikkelsø, A., Dyring Kledal, J., and Christensen, J.S.: 1996, 'Elkvalitet ved nettilslutning af vindmøller. Oversigtsrapport', *Risø-R-853(Summ.)(DA)*, DEFU, Lyngby/DK, Risø National Laboratory, Roskilde /DK, pp. 37.
- Tavoulaareas, E.S., and J.-P. Charpentier: 1995, 'Clean Coal Technologies for Developing Countries', *World Bank Technical Paper Number 286*, The World Bank, New York/US, pp. 83.
- Taylor, J.R.: 1994, *Risk Analysis for Process Plant, Pipelines and Transport*, E & FN Spon, London/UK, pp. 449.
- Teknologinævnet: 1993, *Bilismens fremtid. Slutdokument og scenarier fra konsensuskonferencen 11.-14. juni på Christiansborg*, Danish Technology Council report 1993/3, København 89 pp.
- Teknologinævnet: 1994, *Det lysegrønne landbrug*, Rapport fra koncensuskonference, 1994/5.
- TemaNord: 1995, 'LCA-NORDIC. Technical Reports No 1-9' (Vol. 1), Lindfors, L.-G. *et al.*, *TemaNord 1995:502*, Nordic Council of Ministers, København/DK, pp. 171 + app..
- TemaNord: 1995a, 'LCA-NORDIC. Technical Reports No 10 and Special Reports No 1-2', Lindfors, L.-G. *et al.*, *TemaNord 1995:503*, Nordic Council of Ministers, København/DK, pp. 141 + app. (Vol. 2).
- TEMIS: 1993, *Total Emission Model for Integrated Systems, User's guide for version 2.0* (U. Fritsche, L. Rausch), Oeko-Institute, Darmstadt
- Tivy, J.: 1990, *Agricultural Ecology*, Longman Scientific & Technical, Harlow, Essex/UK, pp. 288.
- Tobin, R.: 1990, *The expendable future: U.S. Policies and the protection of Biological Diversity*, Duke University Press, Durham and London.
- Torres, I.E., Gurmendi, A.C., and Velasco, P.: 1988, *The Mineral Industries of Bolivia, Ecuador, And Peru. 1988 International Review*, U.S. Department of the Interior, Bureau of Mines, Washington/US, pp. 21.
- Trafikministeriet: 1994, *Transportsektorens miljøbelastning*, COWIconsult, Trafikministeriet, København/DK, pp. 86.
- Trafikministeriet: 1995, *Transport, energi og CO<sub>2</sub>-emissioner - debatoplæg*, Trafikministeriet, København/DK, 82 pp.
- Transportrådet: 1993, 'Transportsektorens eksterne effekter', *Notat nr 93.01*, Danmarks Miljøundersøgelser, Transportrådet, København, pp. 73.
- Tsonis, A.A.: 1996, 'Widespread increases in low-frequency variability of precipitation over the past century', *Nature* **382**, 700-702.
- UK-DOE, 1990: 'An Evaluation of Energy Related Greenhouse Gas Emissions and Measures to Ameliorate Them. UK Country Study for the Intergovernmental Panel on Climate Change Response Strategies Working Group. Energy and Industry Sub Group, October 1989', *Energy Paper Number 58*, Librarian, Department of Energy, London/UK, pp. 91.
- UMIP: 1996, *Miljøvurdering af produkter, Projekt vedr. Udvikling af miljøvenlige industriprodukter* (Wenzel *et al.*), Institut for produktudvikling, Danish Technical University
- UN: 1996, *1994 Demographic Yearbook. Annuaire démographique. Forty-sixth issue/Quarante-sixième édition*, United Nations, New York/US, pp. 1131.
- UNEP: 1992, *United Nations Framework Convention on Climate Change*, Genève/CH, pp. 29.
- US Congress: 1992, *Managing industrial solid wastes from manufacturing, mining, oil and gas production, and utility coal combustion-Background paper*, OTA-BP-O-82, Office of Technology Assessment, Washington D.C./US, U.S. Government Printing Office, pp.130.
- US Department of Energy: 1993, *Estimating Externalities of Coal Fuel Cycles*, Oak Ridge Nat. Lab. and Resources for the Future, vol. 3 of *External costs and benefits of fuel cycles*. Oak Ridge, Tennessee

- US Navy: 1940, 'Table of Distances between Ports', *H.O. No. 117*, Hydrographic Office U.S. Navy Department, U.S. Government Printing Office, Washington/US, pp. 443.
- Valasek, V., Roucek, V., Titl, F., Meyers, R.A., Hardgrove, J.M., McClanathan, L., Storsul, S., and Meland, P.: 1993, 'Gravimelt Coal Refinery Project in Czechoslovakia', in *IEA 1993a*, 685-90.
- Vandplan Sjælland: 1995, *Vandplan Sjælland, Hovedrapport 2. fase, 1995*, Frederiksborg Amt, Københavns Amt, Københavns Kommune, Frederiksberg Kommune, Roskilde Amt, Vestsjællands Amt, Storstrøms Amt (eds.), Roskilde Amt/DK, pp. 56 (+32 app.).
- VDI 1992: 'Energiehaushalten und CO<sub>2</sub>-Minderung: Einsparpotentiale im Sektor Stromversorgung, Tagung Würzburg, 25-26.3. 1992', *VDI Berichte 941*, VDI-Verlag, Düsseldorf/DE, 1992 pp. 221.
- VDI: 1991c, 'Soziale Kosten der Energienutzung. Externe Kosten heute – Betriebskosten morgen. Tagung Mannheim/DE, 5. und 6. November 1991, VDI-Gesellschaft Energietechnik', *VDI Berichte 927*, VDI-Verlag, Düsseldorf/DE, pp. 260.
- Vedenik-Novak, M.: 1994, 'Indonesian Coal for Environmental Value in Slovenia Cogeneration Plants', in *IEA 1994e*, pp. 697-703.
- Vesselbo, E.: 1994, *Tal om natur og Miljø*, Danmarks Statistik, Miljøstyrelsen, Skov- og Naturstyrelsen, København/DK, pp. 200.
- Vestergaard, F.: 1996, 'Strategi. Trafikminister Jan Trøjborg vil lade konkurrence og nye materialinvesteringer sikre jernbanes fremtid som transportsystem. Store personalenedskæringer uundgåelige', *Weekendavisen*, 19. sept. 1996.
- Veziroglu, T.N.: 1989, 'Comparison of solar-hydrogen with synthetic fossil fuels', in Kilis and Kakac (eds.) *Energy storage systems*, Kluwer, 431-447.
- Vigon, B.W., Tolle, D.A., Cornaby, B.W., Latham, H.C., Harrison, C.L., Boguski, T.L., Hunt, R.G. and Sellers, J.D.: 1993, 'Life Cycle Assessment: Inventory Guidelines and Principles', Battelle, Franklin Associates Ltd, *EPA/600/R-92/245*, U.S. Environmental Protection Agency, Cincinnati/US, pp. 181.
- Walsh, J., Davis, J., Garms, R (1981). Further studies on the reinvasion of the onchocerciasis control programme by *simulus damnosum* s.l. *Tropical Medicine & Parasitology*, 32, No. 4, 269-273.
- Watson, R.T., Heywood, V.H., Baste, I., Dias, B., Janetos, T., Reid, W., and Ruark, G.: 1995, *Global Biodiversity Assessment. Summary for Policy-Makers*, Cambridge University Press, Cambridge/UK, pp. 46.
- Webster, I.: 1994, 'Carbon Dioxide Capture and Disposal as a Greenhouse Gas Abatement', in *IEA 1994e*, pp. 497-504.
- WEC: 1994, *New Renewable Energy Resources. A Guide to the Future*, World Energy Council, Kogan Page Ltd., London/UK, 391 pp.
- Weiner, J.: 1996, 'Problems in predicting the ecological effects of elevated CO<sub>2</sub>', in Körner, C., and Bazzaz, F.A. (eds.) *Carbon Dioxide, Populations and Communities*, Academic Press, San Diego/US, 432-441.
- Weinreich, S.: 1996, 'Technology description and costs analysis of photovoltaics', in *LTI-project group*, ZEW, Mannheim/DE.
- Werhane, J., Sopocy, D., Stenzel, W., Kalanik, J.B. Tokarski, T.A., and Pace, S.: 1993, 'State-Of-The-Art Power Plant Model (SOAPP)', in *IEA 1993a*, pp. 261-288.
- Wesenberg, C., Bliksted, T., Olesen, O. and Sørensen, P.A.: 1991, *Store Lagre 2. Slutrapport fra projekt lertætnet damvarmelager til solvarmeanlæg, for Energistyrelsen, København, ved Styregruppen for Udvikling af Vedvarende energi*, Copenhagen/DK, pp. 91.
- WHO and NORD: 1985, *Chronic effects of organic solvents on the central nervous system and diagnostic criteria*, World Health Organization, Regional Office for Europe, Copenhagen/DK and Nordic Council for Ministers, Oslo/NO, pp. 273.

- Wiese, A, and Kaltschmitt, M.: 1996, Comparison of wind energy technology with other electricity generation systems - a life-cycle analysis, pp. 169-172 in *1996 European Union Wind Energy Conference*, Stephens & Assoc., Bedford.
- Wigley, T.M.L., Richels, R., and Edmonds, J.A.: 1996, 'Economic and Environmental Choices in the Stabilization of Atmospheric CO<sub>2</sub> Concentrations', *Nature* **379**, 240-243.
- Wittingham, H., and King, C.T.: 1920, *Reed's marine distance tables*, Thomas Reed Printers Ltd, Sutherland/UK, pp. 188.
- Yamada, K., Komiyama, H., Kato, K. and Inabe, A.: 1995, Evaluation of photovoltaic energy systems in terms of economic, energy and CO<sub>2</sub> emissions. University of Tokyo (preprint).
- Zuidema, G, v.d.Born, J, Alcoma, J, Kreileman, G (1994). Simulating changes in global land cover as affected by economic and climatic factors, *Water, Air and Soil Pollution*, **76**, 163-198.



# List of Units and Conversion Factors

## A. Nomenclature for Powers of 10

Prefix	Symbol	Prefix	Symbol
$10^{-18}$	atto	$10^3$	kilo
$10^{-15}$	femto	$10^6$	mega
$10^{-12}$	pico	$10^9$	giga
$10^{-9}$	nano	$10^{12}$	tera
$10^{-6}$	micro	$10^{15}$	peta
$10^{-3}$	milli	$10^{18}$	exa

## B. SI Unit System

Basic Unit	Name	Symbol
length	metre	m
mass	kilogram	kg
time	second	s
electric current	ampere	A
thermodynamical temperature	degree Kelvin	K
luminous intensity	candela	cd
plane angle	radian	rad
solid angle	steradian	sr

Derived Unit	Name	Symbol	Definition
energy	joule	J	$\text{kg m}^2 \text{s}^{-2}$
power	watt	W	$\text{J s}^{-1}$
force	newton	N	$\text{J m}^{-1}$
electric charge	coulomb	C	A s
electric potential difference	volt	V	$\text{J A}^{-1} \text{s}^{-1}$
electric resistance	ohm	$\Omega$	$\text{V A}^{-1}$
electric capacitance	farad	F	$\text{A s V}^{-1}$

Derived Unit	Name	Symbol	Definition
magnetic flux	weber	Wb	V s
inductance	henry	H	V s A <sup>-1</sup>
magnetic flux density	tesla	T	V s m <sup>-2</sup>
luminous flux	lumen	lm	cd sr
illumination	lux	lx	cd sr m <sup>-2</sup>
frequency	hertz	Hz	cycle s <sup>-1</sup>

### C. Conversion Factors

Other Unit	Name	Symbol	Approximate Value
energy	electron volt	eV	$1.6021 \times 10^{-19}$ J
energy	erg	erg	$10^{-7}$ J (exact)
energy	calorie (thermochemical)	cal	4.184 J
energy	British thermal unit	Btu	1055.06 J
energy	Q	Q	$10^{18}$ Btu (exact)
energy	quad	q	$10^{15}$ Btu (exact)
energy	tons oil equiv.	toe	$4.19 \times 10^{10}$ J
energy	barrels oil equiv.	bbl	$5.74 \times 10^9$ J
energy	tons coal equiv.	tce	$2.93 \times 10^{10}$ J
energy	m <sup>3</sup> natural gas		$3.4 \times 10^7$ J
energy	m <sup>3</sup> gasoline		$3.2 \times 10^{10}$ J
energy	kilowatthour	(kWh)	$3.6 \times 10^6$ J
power	horsepower	hp	745.7 W
power	kWh per year	kWh/y	0.114 W
radioactivity	curie	Ci	$3.7 \times 10^8$ s <sup>-1</sup>
temperature	degree Celsius	°C	K - 273.15
temperature	degree Fahrenheit	°F	$\frac{5}{9}^\circ$ C + 32
time	hour	h	3600 s (exact)
time	year	y	8760 h
pressure	atmosphere	atm	$1.013 \times 10^5$ N m <sup>-2</sup>
mass	pound	lb	0.4536 kg
length	foot	ft	0.3048 m

## APPENDIX A: TECHNOLOGY DESCRIPTIONS

### Energy Transformation Chains

#### *Analysis of different energy conversion processes*

In this Appendix we give an overview of the current energy transformation technologies that are being used actively in Denmark, and we shall try to give an outlook into the future of conceivable technologies that could be prevalent and widely used around about the middle of the next century, restricting ourselves to those technologies that are used in the two scenarios considered. Our descriptions of possible future alternatives are based on already published studies, but we aim to extend them with calculations for the externalities. To be able to do this we start with a presentation of the relevant technologies and an analysis of their direct and indirect emissions. Direct means from the very use of the technology, for example smells from a biomass fired power station, indirect means from upstream or downstream activities, for example the leaching of ashes from coal fuelled steel mills.

**Figure A.1 Illustration of direct and indirect impacts**

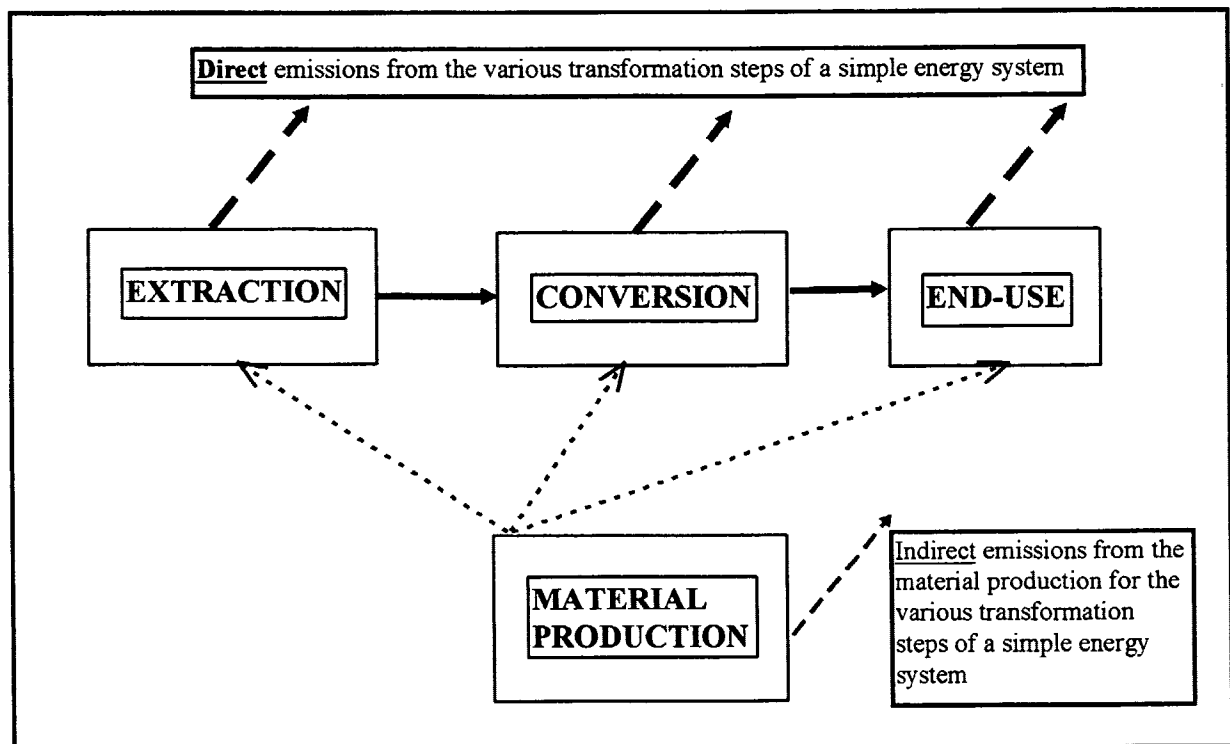

In Figure A.1 an illustration is given of the meaning of direct and indirect impacts from a very simple energy system that only consists of an energy carrier extraction, like a coal mine, one conversion step, like a power station, and one end-use application, like a TV-set. Along the energy chain itself the direct impacts occur. On the other hand, the material production, like a steel mill; producing the machinery used in the mine, or the generator in the power station, or the frame of the TV-set; causes some indirect impacts. These are themselves dependent on the energy system that provides for example the process heat used in the milling process.

*Technology lists (as subsection headers throughout this appendix, we give the acronyms used in the Temis\* database*

The following list is on the technologies considered in our analysis of the present Danish energy system:

### Currently Used Energy Technologies

Technology:	short description of technology
<b>ST-fossil</b>	mostly fossil (coal) fuel fired steam turbines
<b>boilers</b>	mostly waste and natural gas fuelled boilers for district heating
<b>furnace</b>	mostly oil, natural gas and coal fuelled furnaces for process heat
<b>residential</b>	mostly light fuel oil natural gas and wood fired residential heating boilers
<b>hydropower</b>	hydropower installations in Norway or Sweden
<b>onshore</b>	on shore wind turbines
<b>diesLorry</b>	diesel fuelled lorries and heavy purpose vehicles
<b>petrCars</b>	private transportation in gasoline or diesel fuelled cars
<b>diesBuses</b>	public service buses or long range buses
<b>localPT</b>	trains or metros for local public transport
<b>regioPT</b>	trains for regional and international public transport
<b>plane</b>	planes for (inter)national passenger or freight transport
<b>DH&amp;storage</b>	storage and transmission of heat in district heating systems
<b>transmission</b>	transmission of electrical power
<b>pipeline</b>	transmission of either natural gas, biogas or hydrogen via pipes
<b>ratio</b>	rational energy use, energy conservation, difficult to generalise

List of included technologies currently being used in the Danish energy system.

With regards the possible future energy systems, we have to have an idea of what technologies will be being used in the energy conversion processes. Of course we cannot know the future, and therefore our outlooks are not necessarily the right descriptions of what will happen, but rather a description of what is thinkable for the future given the current developments and trends in technology and society.

Certainly the development has been towards a more efficient private sector where the same services as in the past are being performed more rationally, or where new processes and technologies substitute for older, material- and energy intensive ones. This trend will certainly go on in the future, too; it would be futile to assume the opposite, especially in light of a steady sharpening of national and cross-boundary economic competition in effect demanding the most efficient technology to minimise costs.

This trend is included in the description of the chosen energy conversion processes in our future scenarios, as well as we have included new technologies to substitute existing ones. We can, therefore, assume that electricity generation in the future will be much more based on renewable energy technologies. This simply also is a consequence of the public awareness with regards environmental stresses caused by emissions from the current energy system.

The list below shows the perceivable elements of possible future energy systems. We shall in this section describe all those technologies as good as we can and will also give an overview of the materials that are being used. Their production will therefore be an important factor in the estimation of indirect effects and impacts.

### Conversion Technologies Descriptions

In the following we give short technology descriptions and describe the primary energy and material demands for a number of energy conversion technologies used in the scenarios and at present.

\* In the following we use interchangeably the names TEMIS and GEMIS, which are English and German acronyms for "Total Emission Model for Integrated Systems".

## Future Energy Technologies

Technology:	short description
H2mot	hydrogen or biogas fired engines (decentralised heat and power)
HPs	electrically driven heat pumps
onshore	on shore wind turbines
offshore	off shore wind turbines
PV	photovoltaic panels
bioest	biomass residues from agricultural and provisionals production
bioplant	biomass from biomass plantations
biogas	biogas generation from biomass residues or waste
SOFC	biogas or hydrogen fuelled solid oxide fuel cells
liquid	production of liquid biofuels
bioCars	private transportation in biomass fuelled cars
bioBuses	biomass fuelled public service buses or long range buses
localPT	trains or metros for local public transport
regioPT	trains for regional and international public transport
plane	planes for (inter)national passenger transport
bioLorry	liquid biomass fuelled lorries or heavy purpose vehicles
industry	various industrial energy conversion processes, difficult to generalise
DH&storage	storage and transmission of heat in district heating systems
transmission	transmission of electrical power
pipeline	transmission of either natural gas, biogas or hydrogen via pipes
ratio	rational energy use, difficult to generalise

List of technologies that can be perceived to be used in the future Danish energy system.

We do not include a separate description of the various end-use energy technologies because they are not very well investigated, with a few exceptions. Nevertheless we do mention here that they should be included in a complete analysis of the energy system. This is a task for further studies. We give one example of the problems related to end-use technologies in the sections on rational energy use on insulation materials.

We also do not look at the effects of the so-called non-energy uses of fossil fuels, *i.e.* as raw material for plastic production, solvents or as lubricants. Depending on what assumptions are made with regard the disposal or possible recycling of such products they might end up as energy carriers. One example would be old car tires that are being hydrolysed to feed power stations. In that case we ought to include this amount of non-energy fossils as a contribution to emissions into the air of *e.g.* CO<sub>2</sub>.

The physical outputs described in this chapter are being used in a full scale life cycle analysis (LCA) of the products and services.

Please note: For the energy conversion technologies described in the following paragraphs only the direct emissions are shown. Indirect emissions from upstream activities are being integrated by the TEMIS program and are included in the data given in the results and analysis sections.

### *ST-fossil*

Steam turbines are in widespread use and continuously being built. Their use in power plants involves electrical efficiencies that now range from about 40 to 45 per cent<sup>1</sup>. If the exhaust heat is used in a district heating (DH) system, the total efficiency of the systems can be as high as 80 to 95 per cent.

<sup>1</sup> For a comparison combined cycle gas turbines have electrical efficiencies of about 55 per cent.

Table A.1 Lauffen coal power station data sheet

parameter	value	source	remarks
<b>Technical data</b>			
	per unit		
spec. invest.	1308 ε/kW <sup>2</sup>	EC 1995/3, 154	1575 M-DEM <sub>1987</sub>
O&M	3 % pa	DK-DEA 1995a, 9	
capacity	627 MW	EC 1995/3, 84	
annual load	4010 h	EC 1995/3, 84	
lifetime	37 y	EC 1995/3, 84	150 000 h drift
overall net efficiency	37.6 %	EC 1995/3, 84	
<b>Material demand</b>			
	per unit		spec. energy demand
Steel	63 000 t	EC 1995/3, 90	@ 22.2 GJ/t
Concrete (Cement)	175 000 t	EC 1995/3, 90	@ 4.6 GJ/t
Others	2200 t	EC 1995/3, 90	@ 4.6 GJ/t
<b>Material transport</b>			
	per unit		
steel-truck	150 km	EC 1995/3, 90	
steel-railway	50 km	EC 1995/3, 90	
concrete-truck	50 km	EC 1995/3, 90	
others-truck	150 km	EC 1995/3, 90	
others-railway	50 km	EC 1995/3, 90	
<b>Emissions</b>			
	per MWh <sub>d</sub>		
SO <sub>2</sub>	800 g	EC 1995/3, 84	
NO <sub>x</sub>	800 g	EC 1995/3, 84	
particulates	200 g	EC 1995/3, 84	
ash output	35.4 kg	EC 1995/3, 86	
gypsum output	16.8 kg	EC 1995/3, 86	
waste water from FGD	15 kg	EC 1995/3, 86	
waste water from cooling	930 kg	EC 1995/3, 86	
<b>Process demands</b>			
	per MWh <sub>d</sub>		
Lime demand	10 kg	EC 1995/3, 84	
NH <sub>3</sub> demand	1.11 kg	EC 1995/3, 84	
Process water demand	60 kg	EC 1995/3, 84	
<b>Miscellaneous</b>			
Area demand	20 ha	EC 1995/3, 84	
Flue gas volume	2400000 Nm <sup>3</sup> h <sup>-1</sup>	EC 1995/3, 84	
Flue gas temperature	130 C	EC 1995/3, 84	
Stack height	240 m	EC 1995/3, 84	

O&M: yearly operation and maintenance is given as a percentage of the investment throughout this text

Due to basic thermodynamic rules the electricity generation efficiency will be slightly lower for such DH power stations than for pure electricity power stations, as the temperature difference before and after the steam turbine is reduced. Despite this fact the incremental fuel consumption is low so that the extra DH heat can be produced at very favourable costs.

Steam turbine power stations have been undergoing some development in the last decades, they have been equipped with exhaust cleaning, and achievements have been made in raising the thermal efficiencies of today's systems. Nevertheless, because of basic physical laws they can not be improved much more. This technology also is work intensive as it is a mechanical system that needs proper maintenance. It will experience pressure in the coming decades due to both

<sup>2</sup> According to recent rumours the European currency unit, ECU or Euro, shall be denoted by the Greek letter: ε (epsilon), or perhaps rather the Commission's version with a bar in the middle. We are only happy to add to the confusion.

environmental considerations and the upcoming of new, economically promising generation technologies, *e.g.* fuel cells (see SOFC below).

In the present Danish energy system steam turbines are nearly exclusively fuelled with coal. Oil and natural gas are minor fuels. We can use data from the ExternE scenario for these three technologies. To a very low degree these stations are fed with biomass or biogas.

We use the technology described in European Commission (1995c, 84ff.) for a German power station near Lauffen as representative in this respect.

The data for this technology is very abundant, and we can also include a short investigation of the metal content of the ash fractions that, however, only originates from the coal being used in the German power station, and that might not necessarily be representative for the Danish conditions:

**Table A.2 Mass Balance (in weight %) of Trace Elements in Ash Fractions**

Species	Bottom ash	Fly ash	Gypsum/waste water	stack output
As	1.6	88	0.4	-
Cd	1.8	95	3.5	-
Hg	-	17	28	56
Pb	3.1	102	0.9	-

Source: EC (1995/3, 93 f). "-" means: not detectable.

The high concentration of Arsenic, Cadmium and Lead in fly ash is a result of the behaviour of these substances following variations in temperatures during their path through the system (EC 199c, 92). They evaporate easily and condense easily at the small fly ash particles, so they fall out with the fly ash. Quicksilver is depleted in all ashes, as it is very volatile, and so a large part of is released into the environment when it leaves the power station stack as a gas.

#### *Efficiencies of Used Technologies in Denmark Today*

But in fact the Lauffen technology is not representative of the current Danish energy sector except maybe with respect to emission control technology, because Lauffen is a condensing power station that only is used to generate electricity. Following Sørensen *et al.* (1994, 48) the current electricity generation in Denmark is based on combined heat and power plants. This means that we have to extend the principal Lauffen data with an investigation of the energetic efficiencies of such plants (Table A.3).

**Table A.3 Danish power and heat allocation today**

Fuel used	electrical efficiency	thermal efficiency	electrical output	thermal output	$C_m$	source
coal	0.345		91.8			
natural gas	0.320		3.5			DK-DEA 1995a
oil	0.320		4.8			DK-DEA 1995a
biomass	0.23		0.9			DK-DEA 1995a
coal		0.191		50.8	1.806	
natural gas		0.530		5.8	0.604	DK-DEA 1995a
oil		0.530		8.0	0.604	DK-DEA 1995a
biomass		0.610		2.4	0.377	DK-DEA 1995a
total	0.340	0.226	101.0	67.0	1.507	Sørensen <i>et al.</i> 1994

Taking the data from DK-DEA (1995a) and Sørensen *et al.* (1994) we have recalculated the efficiencies of CHP installations in the present Danish energy system.

Output: annual production in PJ.

$C_m$ : is defined by the electrical effect divided by the heat effect (DK-DEA 1995a, 4).

Table A.4 Current power station and CHP plant technological data

fuel	parameter	value	source	remarks	
COAL	<b>Technical data</b>		<b>per unit</b>		
	spec. invest.	908 €/kW	DK-DEA 1995a, 9	7.7 M-DKR <sub>1994</sub>	
	O&M	3 % pa	DK-DEA 1995a, 9		
	capacity	100 MW	GENERIC.PRC	hcoal-cogen-el-HE	
	annual load	5000 h	GENERIC.PRC		
	lifetime	25 y	GENERIC.PRC		
	lifetime generation	12.5 TWh			
	electrical efficiency	34.5 %	own calculations		
	thermal efficiency	19.1 %	own calculations		
	<b>Material demand</b>		<b>per unit</b>		<b>spec. energy demand</b>
	Steel	9000 t	GENERIC.PRC	@ 22.2 GJ/t	
	Concrete (Cement)	10400 t	GENERIC.PRC	@ 4.6 GJ/t	
	<b>Miscellaneous</b>		<b>per unit</b>		
	space demand	10 ha			
	<b>Process demands</b>		<b>per MWh<sub>el</sub></b>		
	Lime demand	10 kg	EC 1995/3, 84	90 % SO <sub>2</sub> abatement	
	NH <sub>3</sub> demand	1.11 kg	EC 1995/3, 84	70 % NO <sub>x</sub> abatement	
Process water demand	60 kg	EC 1995/3, 84	95 % part. abatement		
OIL	<b>Technical data</b>		<b>per unit</b>		
	spec. invest.	590 €/kW	DK-DEA 1995a, 13	5.0 M-DKR <sub>1994</sub>	
	O&M	1.5 % pa	DK-DEA 1995a, 13		
	capacity	385 MW	DK-DEA 1995a, 13		
	annual load	5000 h	GENERIC.PRC	gas-PP-ST-G	
	lifetime	30 y	DK-DEA 1995a, 13		
	lifetime generation	37.75 TWh			
	electrical efficiency	32.0 %	DK-DEA 1995a, 13		
	thermal efficiency	53.0 %	DK-DEA 1995a, 13		
	<b>Material demand</b>		<b>per unit</b>		<b>spec. energy demand</b>
	Steel	25000 t	GENERIC.PRC	@ 22.2 GJ/t	
	Concrete (Cement)	15000 t	GENERIC.PRC	@ 4.6 GJ/t	
	<b>Miscellaneous</b>		<b>per unit</b>		
	space demand	24 ha	Meyer <i>et al.</i> 1994, 97		
	<b>Process demands</b>		<b>per MWh<sub>el</sub></b>		
	Lime demand	10 kg	EC 1995/3, 84	90 % SO <sub>2</sub> abatement	
	NH <sub>3</sub> demand	1.11 kg	EC 1995/3, 84	70 % NO <sub>x</sub> abatement	
NAT. GAS	<b>Technical data</b>		<b>per unit</b>		
	spec. invest.	590 €/kW	DK-DEA 1995a, 22	4.0-6.0 M-DKR <sub>1994</sub>	
	O&M	3 % pa	DK-DEA 1995a, 22	range: 2-4	
	capacity	10 MW	DK-DEA 1995a, 22	range: 5-15	
	annual load	5000 h	GENERIC.PRC	gas-PP-GT-G	
	lifetime	25 y	DK-DEA 1995a, 22		
	lifetime generation	1.25 TWh			
	electrical efficiency	32.0 %	DK-DEA 1995a, 22		
	thermal efficiency	53.0 %	DK-DEA 1995a, 22		
	<b>Material demand</b>		<b>per unit</b>		<b>spec. energy demand</b>
	Steel	7500 t	GENERIC.PRC	@ 22.2 GJ/t	
	Concrete (Cement)	2500 t	GENERIC.PRC	@ 4.6 GJ/t	
	<b>Process demands</b>		<b>per MWh<sub>el</sub></b>		
	NH <sub>3</sub> demand	1.11 kg	EC 1995/3, 84	50 % NO <sub>x</sub> abatement	
	<b>Miscellaneous</b>		<b>per unit</b>		
	Space demand	1 ha			



As can be seen the resultant efficiency of the coal power generation is somewhat lower than that given by the Lauffen data<sup>3</sup>. On the other hand we can now allocate the costs and emissions both to the electricity and heat production and to the various fuel types, as is necessary for a proper calculation. This scheme might seem peculiar, as it would not take into consideration the fact that the different fuels can be burnt in the same kind of power station if it is equipped with a multi-fuel installation. It is an artefact of our representation of the current energy system that is not so "well behaved" as the two for the scenarios, where the process chains have been constructed from the end-use demand upwards and with top-of-the-range technologies for the different energy conversions.

One short remark on the chosen technologies for the oil and natural gas fuel chains. We are aware of the fact that the data, we have given for those technology, are not representative of *e.g.* the Skærbæk power station that is currently under construction. And for natural gas one would probably choose a similar technology or even a gas fired combined cycle power station (DK-DEA, 1995a, 16ff.). In Table A.5 we give representative data for these two technologies.

**Table A.5 Technical data for modern Danish oil and natural gas power stations**

fuel	parameter	value	source	remarks
common data	spec. invest.	590 €/kW	DK-DEA 1995a, 20	4.5-5.0 M-DKR <sub>1994</sub>
	O&M	2.5 % pa	DK-DEA 1995a, 20	range: 2-3
	capacity	400 MW	DK-DEA 1995a, 20	range: 75-400
	annual load	5000 h	GENERIC.PRC	gas-PP-CC-G
	lifetime	30 y	DK-DEA 1995a, 20	
	lifetime generation	60.0 TWh		
	Space demand	1 ha		
<b>OIL</b>	<b>Technical data</b>	<b>per unit</b>		
	electrical efficiency	49.5 %	DK-DEA 1995a, 13	
	thermal efficiency	43.5 %	DK-DEA 1995a, 13	
<b>NAT. GAS</b>	<b>Technical data</b>	<b>per unit</b>		
	electrical efficiency	55.0 %	DK-DEA 1995a, 20	
	thermal efficiency	33.0 %	DK-DEA 1995a, 20	

common data: DK-DEA 1995a gives on page 12 and 13 values that apply for oil or natural gas fuelled advanced steam technology power stations of about 400 MW electrical capacity, and therefore the basic technical figures are comparable.

Modern steam turbines with steam extraction<sup>4</sup> offer good efficiency in the part load operation regime. For capacities smaller than about 75 megawatt new high-efficient non-aeroderivative gas turbines with exhaust steam recovery exhaust boilers might offer advantages compared to aeroderivative gas turbines<sup>5</sup>, especially as the latter only are manufactured in standard sizes (DK-DEA, 1995a, 17ff.), so that it might be difficult to establish a good economy at generation capacities that are not provided for by the manufacturers.

#### *Occupational Health Impacts of the Utility Sector*

We try here to estimate the occupational impacts of the current Danish utility sector. For this purpose we have to have an estimate of the transport work related to the employees' travel to and from work. We can restrict this to the accident rates for private car traffic, as the number of accidents and its share in the total transport work are insignificant from public transport.

<sup>3</sup> Our heat production is very small, and so the  $C_m$  value is too large compared to real installations. This is an artefact of our inclusion of the technical data from DK-DEA (1995a) and our averaging based on data from Sørensen *et al.* (1994).

<sup>4</sup> Called KAD systems in Danish: boilers with advanced steam technology.

<sup>5</sup> They are called aeroderivative gas turbines, as they stem from the gas turbines that are used in aviation.

Trafikministeriet (1995, 16) mentions that in the year 1994 about 31 per cent of the total travels are work related. The total transport work performed by cars was about 56 billion persons kilometres (do, p. 13). This leaves an amount of about 17 billion work-related persons kilometres performed by car, which with 2.66 (=5.15-2.24-0.25; see DS, 1992, 165) million Danes working gives an average transport length of 6,526 kilometres per Dane and year.

Now according to DEF (1993, 38) in the Danish utilities there were 11,767 employees in the year 1992. And in that year those utilities produced 101 petajoule of electricity and 67 petajoule heat (Sørensen *et al.*, 1994, 48). If we set the two energy forms to be of the same energy quality, even though this is not the optimal choice, then the total production of this energy, 168 PJ, is related to a transport work of 76.8 million persons kilometres per year of that part of the total energy sector. This figure has to be corrected for the average occupancy of cars, which is 1.7 (Trafikministeriet, 1994, 76).

According to this data, and using the accident rates from data given in EC (1995/6, 102), we have calculated the accident rates from occupational transport in the present Danish utility sector, Table A.6.

**Table A.6 Danish utility transport accident rates**

accident type	accident rates per mn veh.km	total number of cases	cases per MWh
deaths	0.013	0.587	1.258E-8
major	0.147	6.641	1.423E-7
minor	0.669	30.221	6.476E-7

Sources: EC 1995f, 102; DEF 1993, 38; DS 1992, 165.

Total number of vehicle kilometres: 45.2 million. Total production: 46.67 million MWh.

In comparison the data from occupational accidents from the current utility and energy sector lead to the following figures. We had to add the production figures from district heating and the power sector which gives a yearly net production of 253 PJ. Data from (At, 1992, 13) has been used and aggregated to gain values for deaths, and minor and major accidents, as described in the methodology chapter. It was found that in this sector there were 2 deaths in 1992, 172 major and 344 minor accidents. Table A.7 shows the results.

**Table A.7 Occupational accident rates in Danish utilities**

accident type	total number of cases	cases per MWh
deaths	2	2.85E-08
major	172	2.45E-06
minor	344	4.89E-06

Sources: At 1993, 13.

Total production: 253 PJ

This would be equivalent to total accident rates for the current Danish utilities as given in Table A.8.

**Table A.8 Total Danish utilities' accident rates**

accident type	cases per MWh occup. risks	cases per MWh transport risks	cases per MWh
deaths	2.85E-08	1.258E-8	4.11E-08
major	2.45E-06	1.423E-7	2.59E-06
minor	4.89E-06	6.476E-7	5.54E-06

### Boilers

Today in Denmark boilers are mostly waste or biomass and natural gas fired and they are being used in DH plants. For the representative technology of biomass fired DH boilers we have used data from DK-DEA (1995a, 45 ff.), for waste and natural gas fired installations we used data from GEMIS<sup>6</sup> (1992, 113 ff.).

With regard to straw fired boilers there are corrosion problems, and problems with the Cadmium content of the ashes. They should otherwise be recirculated to prevent losses of potassium and phosphorus in the soils. This problem is especially severe with the fly ash (El'Kholy, 1996), as Cadmium and a series of other heavy metals get concentrated in this fraction which makes up about 30 per cent of the total ash amount (DK-DEA 1995a, 43). It stems from the application of industrial fertiliser containing Cadmium, which is concentrated in the ash.

A possible solution could be better logistics with regard to the recirculation of the ash content, so that different fields will be used each time, and of course the change of the agricultural system to an ecological one, which might reduce the availability of such residues, as there have been arguments on the necessity of keeping a steady supply of carbonaceous matter to the soil.

**Table A.9 Straw fired DH boilers**

parameter	value	source	remarks
<b>Technical data</b>		<b>per unit</b>	
spec. invest.	355 ε/kW	DK-DEA 1995a, 44	3 Mkr <sub>1994</sub> /MJ <sub>s</sub>
O&M	7 % pa	DK-DEA 1995a, 44	range: 6-8
capacity	5 MW <sub>th</sub>	DK-DEA 1995a, 44	range: 1-50 MW <sub>th</sub>
annual load	2500 h	GENERIC.PRC	straw-boiler-DH
lifetime	20 y	DK-DEA 1995a, 44	
lifetime generation	0.25 TWh		
thermal efficiency	82.9 %	Sørensen <i>et al.</i> 1994, 48	
<b>Material demand</b>		<b>per unit</b>	
Steel	10 t	gas-boiler-DH-big	spec. energy demand @ 22.2 GJ/t
<b>Material transport</b>		<b>per unit</b>	
steel-truck	200 km	EC 1995/3, 90	
<b>Emissions</b>		<b>per MWh<sub>th</sub></b>	
SO <sub>2</sub>	391 g	GEMIS 1992, 111	recalculated
NO <sub>x</sub>	1086 g	GEMIS 1992, 111	recalculated
particulates	10857 g	GEMIS 1992, 111	recalculated
<b>Miscellaneous</b>			
Area demand	1 ha		

**recalculated:** as GEMIS gives data in kg per Terajoule fuel we had to calculate the emissions for the thermal output.

For waste incineration plants we have used data from Nielsen (1994) and DK-DEA (1995a). According to the latter source there are problems with corrosion, the falling demand for this kind of technology during the introduction of biogas production, and with the reuse of the ashes and slags that result after incineration. The last point is related to the chlorine content of household wastes from various sorts of plastics. We may also mention the creation of dioxins that are produced in rather small amounts, and so may only pose minor environmental or health problems.

<sup>6</sup> The GEMIS program was first produced for a German regional government (described in GEMIS (1992), and later translated into English. We have used the English version, called TEMIS v2.0 (TEMIS, 1993).

Approaches to reduce *e.g.* the use of PVC<sup>7</sup> as packing material are taking place, its use is being scrutinised, and for parts of the detail chain, like IRMA supermarkets, a trend towards abolition of its use is going on. At the same time environmental organisations as NOAH and GREEN-PEACE put pressure on the political system to acknowledge and eventually avoid the consequences the production of chlorinated organic substances brings about with respect to direct and indirect effects<sup>8</sup>. Therefore we assume that this problem will be solved in the long run.

Table A.10 Natural gas fired boilers

parameter	value	source	remarks
<b>Technical data</b>			
<b>per unit</b>			
spec. invest.	295 €/kW	DK-DEA 1995a, 41	2-3 Mkr <sub>1994</sub> /MJ.s
O&M	3 % pa	DK-DEA 1995a, 41	range: 2-5
capacity	10 MW <sub>th</sub>	DK-DEA 1995a, 41	range: 0.5-20 MW <sub>th</sub>
annual load	2500 h	GENERIC.PRC	gas-boiler-DH-big
lifetime	20 y	DK-DEA 1995a, 41	
lifetime generation	0.5 TWh		
thermal efficiency	82.9 %	Sørensen <i>et al.</i> 1994, 48	
<b>Material demand</b>			
<b>per unit</b>			
Steel	20 t	GENERIC.PRC	spec. energy demand @ 22.2 GJ/t
<b>Material transport</b>			
<b>per unit</b>			
steel-truck	200 km	EC 1995/3, 90	
<b>Emissions</b>			
<b>per MWh<sub>th</sub></b>			
SO <sub>2</sub>	1.7 g	GEMIS 1992, 111	recalculated
NO <sub>x</sub>	122 g	GEMIS 1992, 111	recalculated
particulates	0.4 g	GEMIS 1992, 111	recalculated
<b>Miscellaneous</b>			
Area demand	1 ha		

recalculated: as GEMIS gives data in kg per Terajoule fuel we had to calculate the emissions for the thermal output.

Table A.11 Waste incineration DH boilers

parameter	value	source	remarks
<b>Technical data</b>			
<b>per unit</b>			
spec. invest.	3650 €/kW	Nielsen 1994, 113	2005-value used
O&M	3.5 % pa	Nielsen 1994, 113	
capacity	25 MW <sub>th</sub>	DK-DEA 1995a, 26	range: 13-53 MW <sub>th</sub>
annual load	6600 h	GENERIC.PRC	waste-PP-ST
lifetime	20 y	DK-DEA 1995a, 26	
lifetime generation	3.3 TWh		
thermal efficiency	82.9 %	Sørensen <i>et al.</i> 1994, 48	
<b>Material demand</b>			
<b>per unit</b>			
Steel	5000 t	GENERIC.PRC	@ 22.2 GJ/t
Concrete (Cement)	10000 t	GENERIC.PRC	@ 4.6 GJ/t
<b>Material transport</b>			
<b>per unit</b>			
steel-truck	200 km	EC 1995/3, 90	
concrete-truck	50 km	EC 1995/3, 90	
<b>Emissions</b>			
<b>per MWh<sub>th</sub></b>			
SO <sub>2</sub>	126 g	GEMIS 1992, 117	recalculated
NO <sub>x</sub>	760 g	GEMIS 1992, 117	recalculated
particulates	53 g	GEMIS 1992, 117	recalculated
<b>Miscellaneous</b>			
Area demand	1 ha		

recalculated: as TEMIS gives data in kg per Terajoule fuel we had to calculate the emissions for the thermal output.

<sup>7</sup> Polychlorinated vinyl.

<sup>8</sup> direct here means high energy demand during production, and indirect episodes such as the Bhopal incident.

At the same time our future scenarios rely on the implementation of biogasification as a means to recycle the energy content of household and parts of the industrial wastes. This means that we only have to describe the current impacts from this technology, and so do not have to define them for any future situation.

### Furnace

Presently the Danish energy system employs furnaces in the industry sector to generate process heat mostly as fuel oil, natural gas and coal fired. In the ecologically sustainable and the fair market scenario furnaces are biogas fired. In the fair market scenario we do not have explicitly stated the use of biogas fuelled furnaces, but we can conclude that a large share of the biogas in that scenario in fact will be used to generate medium to high temperature process heat.

**Table A.12 Data on oil fired industrial furnaces**

parameter	value	source	remarks
<b>Technical data</b>		<b>per unit</b>	
spec. invest.	295 €/kW	DK-DEA 1995a, 41	2-3 Mkr <sub>1994</sub> /MJ.s
O&M	3 % pa	DK-DEA 1995a, 41	range: 2-5
capacity	100 MW <sub>th</sub>	GEMIS 1992, 101	range: 50-300
annual load	4000 h	GENERIC.PRC	oil-H-boiler-ind-G
lifetime	20 y	GENERIC.PRC	
lifetime generation	8.0 TWh		
thermal efficiency	82.2 %	Sørensen <i>et al.</i> 1994, 48	
<b>Material demand</b>		<b>per unit</b>	
Steel	150 t	GENERIC.PRC	spec. energy demand @ 22.2 GJ/t
<b>Material transport</b>		<b>per unit</b>	
steel-truck	200 km	EC 1995/3, 90	
<b>Emissions</b>		<b>per MWh<sub>th</sub></b>	
SO <sub>2</sub>	2150 g	GEMIS 1992, 101	recalculated
NO <sub>x</sub>	502 g	GEMIS 1992, 101	recalculated
particulates	50 g	GEMIS 1992, 101	recalculated
<b>Miscellaneous</b>			
Area demand	1 ha		

recalculated: as TEMIS gives data in kg per Terajoule fuel we had to calculate the emissions for the thermal output.

**Table A.13 Data for natural gas fired industrial furnaces**

parameter	value	source	remarks
<b>Technical data</b>		<b>per unit</b>	
spec. invest.	295 €/kW	DK-DEA 1995a, 41	2-3 Mkr <sub>1994</sub> /MJ.s
O&M	3 % pa	DK-DEA 1995a, 41	range: 2-5
capacity	10 MW <sub>th</sub>	GEMIS 1992, 103	
annual load	2500 h	GENERIC.PRC	gas-boiler-ind-NL
lifetime	20 y	DK-DEA 1995a, 41	
lifetime generation	0.5 TWh		
thermal efficiency	82.2 %	Sørensen <i>et al.</i> 1994, 48	
<b>Material demand</b>		<b>per unit</b>	
Steel	150 t	GENERIC.PRC	spec. energy demand @ 22.2 GJ/t
<b>Material transport</b>		<b>per unit</b>	
steel-truck	200 km	EC 1995/3, 90	
<b>Emissions</b>		<b>per MWh<sub>th</sub></b>	
SO <sub>2</sub>	1.8 g	GEMIS 1992, 103	recalculated
NO <sub>x</sub>	123 g	GEMIS 1992, 103	recalculated
particulates	0.4 g	GEMIS 1992, 103	recalculated
<b>Miscellaneous</b>			
Area demand	1 ha		

recalculated: as TEMIS gives data in kg per Terajoule fuel we had to calculate the emissions for the thermal output.

We will use the data from DK-DEA (1996a) and DK-DEA (1995a) for the economic and environmental assessments of these technologies.

Also for coal fired industrial furnaces we have relied on the TEMIS database, where we have assumed a circulating fluidised bed combustion technique:

**Table A.14 Data on coal fired industrial furnace**

parameter	value	source	remarks
<b>Technical data</b>			
	<b>per unit</b>		
spec. invest.	930 ε/kW	DK-DEA 1995a, 97	7.9 Mkr <sub>1994</sub> /MJ.s
O&M	4 % pa	DK-DEA 1995a, 41	
capacity	50 MW <sub>th</sub>	GEMIS 1992, 96	range: 5-50 MW <sub>th</sub>
annual load	4500 h	GENERIC.PRC	hcoal-boiler-FBC-ind
lifetime	25 y	GENERIC.PRC	
lifetime generation	5.6 TWh		
thermal efficiency	82.2 %	Sørensen <i>et al.</i> 1994, 48	
<b>Material demand</b>			
	<b>per unit</b>		
Steel	60 t	GENERIC.PRC	
Concrete (Cement)	5 t	GENERIC.PRC	
<b>Material transport</b>			
	<b>per unit</b>		
steel-truck	200 km	EC 1995/3, 90	
concrete-truck	50 km	EC 1995/3, 90	
<b>Emissions</b>			
	<b>per MWh<sub>th</sub></b>		
SO <sub>2</sub>	536 g	GEMIS 1992, 96	recalculated
NO <sub>x</sub>	495 g	GEMIS 1992, 96	recalculated
particulates	67 g	GEMIS 1992, 96	recalculated
<b>Miscellaneous</b>			
Area demand	1 ha		

recalculated: as GEMIS gives data in kg per Terajoule fuel we had to calculate the emissions for the thermal output.

**Table A.15 Data on oil fired residential heating**

parameter	value	source	remarks
<b>Technical data</b>			
	<b>per unit</b>		
spec. invest.	420 ε/kW	GENERIC.PRC	oil-L-heating-atmo
O&M	2.0 % pa	GENERIC.PRC	
capacity	10 kW	GENERIC.PRC	
annual load	1600 h	GENERIC.PRC	
lifetime	15 y	GENERIC.PRC	
lifetime generation	240 MWh		
thermal efficiency	64.8 %	Sørensen <i>et al.</i> 1994, 48	
<b>Material demand</b>			
	<b>per unit</b>		
Steel	500 kg	GENERIC.PRC	spec. energy demand
Concrete (Cement)	100 kg	GENERIC.PRC	@ 22.2 GJ/t
			@ 4.6 GJ/t
<b>Material transport</b>			
	<b>per unit</b>		
steel-truck	200 km	EC 1995/3, 90	
concrete-truck	50 km	EC 1995/3, 90	
<b>Emissions</b>			
	<b>per MWh<sub>th</sub></b>		
SO <sub>2</sub>	316 g	GENERIC.PRC	
NO <sub>x</sub>	169 g	GENERIC.PRC	
particulates	20 g	GENERIC.PRC	
<b>Process demands</b>			
	<b>per MWh<sub>th</sub></b>		
local electricity	0.01	GENERIC.PRC	
light fuel-oil	50 km	estimate	road tank transport

the transport length for the fuel oil is estimated.

*Residential*

The residential heating sector in Denmark despite a pronounced trend towards DH systems still relies very much on small scale technologies like separate natural gas or fuel oil fired boilers. In the two scenarios they will be substituted by district heating and biogas fuelled boilers. But to describe the current situation we have to include a description of the currently used technologies, anyway.

The very problem with these small scale technologies is emissions of potentially hazardous substances at a low stack height and the lack of convenient control technologies to catalyse or clean the emissions at the source. Therefore we have a large contribution from dispersed local sources that leads to potentially large public health impacts. The consequences of these emissions can not be described properly today, as lack of the impact potential prevents a quantification and monetisation of the impacts.

We give the overall system efficiency including different losses. For residential gas heating we rely to a large degree on the TEMIS database, GENERIC.PRC, especially with the particulates emissions for which GEMIS (1992, 103) gives references.

**Table A.16 Data for natural gas fired residential heating**

parameter	value	source	remarks
<b>Technical data</b>			
	per unit		
spec. invest.	300 ε/kW	DK-DEA 1995a, 44	gas-heating-atmosph
O&M	2.5 % pa	GENERIC.PRC	
capacity	10 kW	GENERIC.PRC	
annual load	1600 h	GENERIC.PRC	
lifetime	15 y	GENERIC.PRC	
lifetime generation	240 MWh		
thermal efficiency	64.8 %	Sørensen <i>et al.</i> 1994, 48	
<b>Material demand</b>			
	per unit		spec. energy demand
Steel	100 kg	GENERIC.PRC	@ 22.2 GJ/t
<b>Material transport</b>			
	per unit		
steel-truck	250 km	EC 1995/3, 90	
<b>Emissions</b>			
	per MWh <sub>th</sub>		
SO <sub>2</sub>	1.8 g	GENERIC.PRC	
NO <sub>x</sub>	170 g	GENERIC.PRC	
particulates	0.4 g	GEMIS 1992, 103	recalculated
<b>Process demands</b>			
	per MWh <sub>th</sub>		
local electricity	0.01	GENERIC.PRC	

**recalculated:** as GEMIS gives data in kg per Terajoule fuel we had to calculate the emissions for the thermal output.

According to OECD (1988, 55) domestic wood combustion generally is very inefficient, about 50 %, and due to the low release height of short stacks and low flue gas velocities impacts will be greater than from comparable large scale industrial or utility applications. Therefore domestic wood combustion under the generally bad control of the firing process (GEMIS, 1992, 112) and lack of emission controls will be accompanied by emissions of a wide variety of organic compounds. This is a factor we can not treat in detail, let us suffice with quoting from OECD (1988, 55):

**Table A.17 Emissions and impacts in wood combustion**

Characterisation	Examples
organic compounds:	acids, aldehydes, phenols, benzo(a)pyrene, PAH
solid wastes:	ashes
particulates:	dust
other:	house fires by unsafe installations

For the wood fired residential heating systems have we relied on the TEMIS database.

**Table A.18 Data on wood fired residential heating**

parameter	value	source	remarks
<b>Technical data</b>			
	<b>per unit</b>		
spec. invest.	480 €/kW	GENERIC.PRC	wood-heating
O&M	5 % pa	DK-DEA 1995a, 44	
capacity	10 kW <sub>th</sub>	GENERIC.PRC	
annual load	1600 h	GENERIC.PRC	
lifetime	20 y	estimate	
lifetime generation	320 MWh		
thermal efficiency	64.8 %	Sørensen <i>et al.</i> 1994, 48	
<b>Material demand</b>			
	<b>per unit</b>		
Steel	250 kg	GENERIC.PRC	spec. energy demand @ 22.2 GJ/t
<b>Material transport</b>			
	<b>per unit</b>		
steel-truck	200 km	EC 1995/3, 90	
<b>Emissions</b>			
	<b>per MWh<sub>th</sub></b>		
SO <sub>2</sub>	278 g	GEMIS 1992, 113	recalculated
NO <sub>x</sub>	556 g	GEMIS 1992, 113	recalculated
particulates	556 g	GEMIS 1992, 113	recalculated
<b>Miscellaneous</b>			
SO <sub>2</sub> abatement	15.9 %	GEMIS 1992, 112	SO <sub>2</sub> uptake in ash
process demands diligence		GEMIS 1992, 112	

**recalculated:** as GEMIS gives data in kg per Terajoule fuel we had to calculate the emissions for the thermal output.

### *Onshore*

On shore wind turbines have been developed in the last decades to extract the kinetic energy of the wind and to generate electricity. Table A.19 gives some data on the current technology.

**Table A.19 Current onshore wind converter data sheet**

parameter	value	source	remarks
<b>Technical data</b>			
	<b>per unit</b>		
spec. invest.	950 €/kW	Nielsen 1994, 113	
O&M	1.5 % pa	Nielsen 1994, 113	
capacity	400 kW	EC 1995/6, 88	
annual load	2000 h	EC 1995/6, 88	load factor: 0.3
lifetime	20 y	EC 1995/6, 88	1990
lifetime generation	16.0 TWh		
<b>Material demand</b>			
	<b>per unit</b>		
Glass reinforced plastic	4.5 t	EC 1995/6, 88	spec. energy demand @ 30.9 GJ/t
Copper	0.625 t	EC 1995/6, 88	@ 21.8 GJ/t
Steel	37.375 t	EC 1995/6, 88	@ 22.2 GJ/t
Concrete (Cement)	42.5 t	EC 1995/6, 88	@ 4.6 GJ/t

We expect the substitution of steel with other materials in the future, like bio-based plastics (PHA or PHB). This development needs to be investigated further, especially with respect to the work environment that outgassing of binders and solvents pose to the workers in such industries. This is a recurrent problem related to a complete LCA of an energy system, where such indirect impacts hardly can be assessed properly, and where we therefore have to mention a lack of statistical data material to perform a decent analysis.

### *Occupational Health Impacts from Wind Turbine Construction and Maintenance*

From values found in DS (1993) and At (1992) we can estimate the occupational accident risk in Danish wind turbine manufacturing. The Danish values that have been used are aggregated data



for the machine industry sector, the resultant accident rates are slightly higher than the respective British ones, that were used in EC (1995f). As in EC (1995f) we calculate the accident rate of a wind park installation and operation and maintenance activities. The results are presented in Table A.21. Our value for accidents related to O&M is given separately. It is about an order of magnitude higher than the rates from manufacturing alone and has to be added to gain the total value.

**Table A.20 Future onshore wind converter data sheet**

parameter	value	source	remarks
<b>Technical data</b>		<b>per unit</b>	
spec. invest.	890 ε/kW	Nielsen 1994, 113	
O&M	1.5 % pa	Nielsen 1994, 113	
capacity	1 MW	GENERIC.PRC	wind-PP-large
annual load	2500 h	GENERIC.PRC	
lifetime	25 y	estimate	after 2030
lifetime generation	62.5 GWh		
<b>Material demand</b>		<b>per unit</b>	
			spec. energy demand
Glass reinforced plastic:	10 t	GENERIC.PRC	@ 30.9 GJ/t
Steel	125 t	GENERIC.PRC	@ 22.2 GJ/t
Copper	1.25 t	1 % of steel amount	@ 21.8 GJ/t
Concrete (Cement)	750 t	GENERIC.PRC	@ 4.6 GJ/t

**Table A.21 Occupational transport accidents from wind turbine construction and O&M**

accident type	accident rates	number of cases	Current onshore	Future onshore	Future offshore	O&M
	per mn veh.km	per bn ε	cases per MWh			
deaths	0.013	0.28	6.74 E-9	4.00E-9	4.31E-9	2.52E-8
major	0.147	153.2	3.83E-6	2.18E-6	2.35E-6	2.85E-7
minor	0.669	295.8	7.10E-6	4.21E-6	4.54E-6	1.30E-6

Sources: EC 1995/6: 101f.; At 1992: 10; DS 1993: 6-9.

The accident rate computation from O&M activities gives the major part of the occupational accident impacts, but it rests on very conservative assumptions. In EC (1995f) a 200 gigawatthour wind mill park is described that is being visited 200 days per year by a staff of 8 who each travel a return trip of 100 kilometres to the wind park! Such an intensive care is maybe not realistic to assume, not today and even less so in the future, when improvements in turbine and tower design will minimise failure rates and consequently maintenance demand. Actual values will very likely be much lower!

#### *Noise and Visual Impacts*

Noise is an externality for wind mills as it has some qualities typical of classical pollution. It influences the environment outside the installation, affects population in general at least in the region near to the wind turbine installations, and normally there will be no requirements for compensation payments (EC 1995/6, 51). In EC (1995/6, 52 f.) the damage from wind mill was estimated to be between 0.07 and 1.1 mECU per kilowatthour, although higher values might occur for very scenic locations. We will use the mean value, 0.59 mECU per kWh in our externality calculations for on-shore wind turbine electricity production.

Due to the larger distances to residential areas we assume noise not play any role for off-shore wind turbines.

There are some visual impacts from wind mills. In EC (1995/6, 82) a value of 0.1 mECU per kilowatt-hour is given as the best estimate for normal land-based locations. This value is the best that we can find, and we will apply this value directly in the monetarisation of the impacts.

We also think that there might be some visual impacts from off-shore wind mills. However, the value just quoted is probably too high in that respect. Also one could argue for negative values for this impact from the fact that the installations of off-shore wind mills with their reef-like structures could be a very attractive location for private fishing excursions. If this turns out to be a case then those benefits might outweigh the costs from the visual obstruction of the clear horizon line. Still, we have chosen to use the same value for off-shore wind mills' visual intrusion as for on-shore wind parks.

To what degree off-shore wind parks will turn out to be dangerous for shipping routes, is a problem that should be investigated. We assume that the ideas on large bridge installations could be applied for the risk assessment of the off-shore wind mill islands, too. Those values probably will turn out to be low.

### *Offshore*

Offshore wind turbines are a promising technology and good experiences have been made at Thunø Knob, where the first large Danish off-shore wind park has become operational recently. We are basing our data on the GEMIS programme (GEMIS, 1992, 141) for this technology where we use the data given for large wind converters, Table A.22. On the occupational accident rates of wind turbine production and O&M please look at Table A.21 in the section of on-shore wind turbines just before. Estimates on visual impacts and noise can be found in the on-shore section just before.

**Table A.22 off-shore wind converter data**

parameter	value	source	remarks
<b>Technical data</b>		<b>per unit</b>	
spec. invest.	960 ε/kW	Nielsen 1994, 113	
O&M	2.0 % pa	Nielsen 1994, 113	
capacity	3 MW	estimate	
annual load	2500 h		
lifetime	25 y	estimate	
lifetime generation	187.5 GWh		
<b>Material demand</b>		<b>per unit</b>	
Glass reinforced plastic:	25 t	estimate	@ 30.9 GJ/t
Steel	250 t	estimate	@ 22.2 GJ/t
Copper	2.5 t	1 % of steel amount	@ 21.8 GJ/t
Concrete (Cement)	1500 t	estimate	@ 4.6 GJ/t

These data are estimated by doubling the values for the 1 MW future on shore technology data, see Table A.20.

This technology is currently being developed. Although our data might be somewhat pessimistic with respect to the material input for the tower construction, where we assume a high amount of concrete, this choice can be defended by the extra amount of material needed for creating the small island-like structures whereupon the towers and wind mills will have to be installed. This necessitates a large amount of concrete as the basic, bearing structure. With respect to the tower itself, the 250 tons of steel might be a good estimate, although our source (GEMIS, 1992) for the large wind mill data is not explicit about the material composition of tower and turbine, respectively.

There is not considered any possible extra material demand for electrical installations, like the transfer cables to the power net on the land. This materials probably will not be a dominant factor. The copper amount itself is being taken to be one per cent of the total steel amount, this is a rule of thumb value for the copper in the generator.

## PV

Photovoltaic (PV) panels are a means to exploit the vast solar resource that is provided for by radiation reaching the Earth from the Sun, an energy amount of 174,000 TW for the complete sphere of the Earth (WEC, 1994, 65) and equivalent to an irradiation of about 1000 kWh per square metre in Denmark (Phylipsen and Alsema, 1995, 42, actually a value given for the Netherlands, but the Danish figure should not be too different). PV panels work by physical processes by which the light energy is being used in quantum-mechanical processes to create an electrical potential that can be used for generating power.

The basic material for the active element of a panel, the so-called wafer, is a semiconductor, today mostly silicon (this substance is also assumed to be the bearing material in the future, see the discussions below on data from Phylipsen and Alsema (1995)), but other materials, like copper indium diselenide or cadmium telluride are being investigated. The latter would have the disadvantage of possible releases of cadmium into the environment from leaking from the panels after an accident or after simple disposal.

Technical PV panel data can be found for example in GEMIS (1992), Baumann and Hill (1993) or Sørensen (1993 and 1995). We have used the data from Weinreich (1996) and extended them with data from (GEMIS 1992), see Table A.23. Our data are for whole modules where we assume that no further construction is necessary as they will be used as facade elements in decentralised units. On the other hand we do not allocate any bonus in the calculation of the scenarios to this double use even though it in principle represents rational energy use (saving production of extra facade elements).

**Table A.23 PV technology technical data.**

parameter	value	source	remarks
<b>Technical data</b>		<b>per unit</b>	
specific investment	6200 ε/kW	Weinreich 1996, 5	today
specific investment	2500 ε/kW	Weinreich 1996, 4	2030
specific investment	1500 ε/kW	Weinreich 1996, 5	2050
O&M	1 % pa	Weinreich 1996, 5	
system efficiency	10.1 %	Weinreich 1996a, 9	today
system efficiency	15.9 %	Weinreich 1996a, 9	2030
system efficiency	18.4 %	Weinreich 1996a, 9	2050
specific energy yield pr kWp	774 kWh/y	Weinreich 1996a, 14	today
specific energy yield pr kWp	947 kWh/y	Weinreich 1996a, 14	2030
capacity	10 kW	GEMIS 1992, 141	
annual load	1000 h	Weinreich 1996	
lifetime	25 y	Weinreich 1996, 5	
lifetime generation	250 MWh		
<b>Material demand</b>		<b>per unit</b>	
Copper	0.2 t	GEMIS 1992, 141	@ 21.8 GJ/t
Steel	1.5 t	GEMIS 1992, 141	@ 22.2 GJ/t
Glass	0.75 t	GEMIS 1992, 141	@ 30.9 GJ/t
Plastics	0.5 t	GEMIS 1992, 141	(?)
Silicon	0.25 t	GEMIS 1992, 141	(?)
Concrete (Cement)	0.001 t	guestimate	@ 4.6 GJ/t
<b>Occupational risks O&amp;M</b>		<b>per MWh</b>	
deaths	3 E <sup>-8</sup>	Sørensen 1993, 15	based on Hohmeyer 1988
Work hours lost	1.5 E <sup>-3</sup>	Sørensen 1993, 15	based on Hohmeyer 1988

"ε" means ECU

An investigation of the differences with respect to the various technologies has not found major differences between the environmental impacts from the energy provision for the production of the panels for a technology given in or alternatively other panel data from GEMIS (1992) or data

given in Phylipsen and Alsema (1995). This result might seem astonishing, but it can be explained by the different material composition of the panels that is assumed in the literature.

For polycrystalline Silicon based modules Phylipsen and Alsema (1995) have conducted a very explicit LCA. When we cite their data in we have chosen to use their best case values. Those are given as representative of the technologies used around 2010 from an optimistic point of view (Phylipsen and Alsema, 1995, 5), and so are the best estimate that we have for technology valid in 2030 (ecologically sustainable scenario) or 2050 (fair market scenario), see the scenario chapters for a proper definition of those two.

**Table A.24 Material consumption for best case PV panels (Phylipsen and Alsema, 1995)**

material	process	kg/m <sup>2</sup> cell area
quartz	Si-production	2.03
high purity C	high purity Si production	0.84
HCl (20%)	do.	43.00
Na <sub>2</sub> CO <sub>3</sub>	do.	0.69
CaCO <sub>3</sub>	do.	1.29
Al <sub>2</sub> O <sub>3</sub>	do.	0.76
Ar gas	casting	0.26
Min. oil	wafering	0.46
SiC	do.	0.60
NaOH	etching/texturing	0.61
H <sub>2</sub> SO <sub>4</sub>	do.	0.45
Ag-paste	metallisation	0.004
Al-paste	do.	0.006
N <sub>2</sub>	passivation/ARC	0.10
Ti(CH <sub>3</sub> ) <sub>2</sub> CHO] <sub>4</sub>	ARC	0.009
Sn-coated Cu-strips	module assembly	0.022
EVA foil	do.	0.55
chem.hardened glass	do.	8.12
Tedlar/Al/Tedlar	do.	0.16
Al (in Tedlar)	do.	0.0002
polyester	do.	0.49
silicon adhesive	do.	0.042
Al	framing	1.60
polysulphide elastomer	do.	0.67
Total		62.76

Table A.24 shows the material composition of the PV panels as assumed in by Phylipsen and Alsema (1995). The authors describe very well the different production steps of a PV panel with a very detailed analysis of the chemicals used, and also perform an energy pay-back analysis. The degree of detailisation is too high to do a proper analysis with the TEMIS program, as this would imply an investigation of the energy demand for all the different chemicals that are used in the process. So we were forced to aggregate a group of substances, as is shown in Table A.25.

What we have done is to aggregate according to the nearest class of materials that we had represented in the TEMIS program database. So aluminium and Al-compounds were represented by aluminium, we used chalk to represent quartz, as it also leads to dust and particle emissions. Other metals and compounds were represented by copper. For HCl the data for NaOH were used, the

two compounds have related production steps, so this can be defended by a mere allocation choice. Plastic compounds were assumed to be represented by oil-products and silicon or its compounds were represented by silicon production.

**Table A.25 PV panel materials as included in TEMIS program material database**

Material given in TEMIS	Amount (kg/m <sup>2</sup> panel area)
Aluminium	1.6002
chalk	2.74
charcoal/petr.coke	0.84
Copper	0.022
glass	8.12
NaOH	44.06
nitrogen	0.36
oil products	2.37
Silicon	2.65
<b>Total</b>	<b>62.76</b>

These data are the gross material input for a 1 m<sup>2</sup> PV panel that is described in Phylipsen and Alsema (1995, 42) to lead to an electricity production of 153 kWh in the Netherlands. We have assumed that the same value is applicable to Denmark, too, although one would assume that substances like NaOH would be recycled. To calculate an energy pay back time, *i.e.* the time it takes for the PV panel to produce as much energy, as has been used in the production of it, of 0.7 years (do.), if we also take into consideration the energy used for producing the aluminium frame. The life time is assumed to be 30 years (do. p. 48), which gives an electricity generation of 4590 kWh over one panel's lifetime.

After the technological life time has elapsed, generally the modules would be disposed of. Phylipsen and Alsema (1995, 26) do, however, acknowledge possible environmental considerations that could enforce different ways of re-use or recycling, for example the thresholds set by the current Dutch environmental regulations might be surpassed for the silver and copper content of the panels, that are given as 5 grams per kilogram each. Currently the copper content would range between 2 and 5 grams, and the silver content between 0.4 and 5 grams.

But as silver is a very expensive material, its use can be expected to be reduced in the future. Especially one argument should seem to enforce such substitution trends: with current technology a PV contribution of 5 % to the current World electricity production would require about 50 % of the current silver production (Phylipsen and Alsema, 1995, 32-33). Also silver is not in unlimited supply. Schmidt *et al.* (1994, 23) give the supply horizon of the metal to be between 19 and 29 years for current production relative to reserves or the resources – according to the definition given in IPCC II (1996, 85-86). But we also have to mention that the chosen technology can be substituted by other types of PV cells that are based on other materials, and so might offer ways to reduce the demand for such rare metals.

For the aluminium framing recycling of the aluminium might become a major way of reducing the energy consumption required for the panels. Primary aluminium is very energy intensive (almost 20 MJ per kg, Phylipsen and Alsema, 1995, 45) compared to recycled aluminium (5-8 MJ/kg, do.), although the energy demand for extruding and anodising will be the same (do.) This will reduce energy demand for the aluminium parts of the panel. If we calculate the LCA impacts from the PV panels we still will assume no recycling of the aluminium parts, or of the other substances, where we use the data for aluminium in the GEMIS program as a substitute for other materials.

Likewise we do not assume that glass will be recycled for the use with PV panels in the future, as the optical demands for it are very high (Phylipsen and Alsema, 1995, 45-46), and the energy amount that can be saved from recycling glass seems to be small compared to the energy input for the other materials, notably silicon and aluminium.

#### *Energetic Efficiency of PV panels*

Citing from Phylipsen and Alsema (1995, 51) their primary energy requirements for delivering one gigawatthour of electricity from a PV panel depends very much on the developments in the industry. There is a factor 16 between the "emissions" of PV electricity of the best case technology and the worst case, Table A. 26.

**Table A. 26 PV "emissions"**

<i>emission of:</i>	<i>PV worst case</i>	<i>PV base case</i>	<i>PV best case</i>	<i>average Dutch elec. supply</i>
CO <sub>2</sub> (kg/GWhe)	167000	31000	9800	666000
SO <sub>2</sub> (kg/GWhe)	315	58	18	870
NO <sub>x</sub> (kg/GWhe)	370	68	21	1210
Acidification potential (kg/GWhe)	574	106	33	1720
primary energy consumption (TJ)	2400	450	140	9000

#### *Occupational and Public Health Risks of Installations*

As this technology is rather young, there are not many life cycle data in the literature for it. Impacts normally are only identified and not quantified, e.g. in Sørensen (1993). This is especially the case for the production of PV panels, where various chemicals with potentially hazardous impacts are being used, or liberated during various process steps, like volatile organic substances during panel laminating (Phylipsen and Alsema, 1995, 25). Still, we know that the current production is very labour intensive and not automated to a high degree. So the production will very likely undergo major changes in the near future, and will necessarily have to, as the high labour demand also means high prices. This industrialisation of the production implies that the workers' possible exposition to hazardous substances will go down drastically, and this will have consequences for an investigation of the work environment impacts of PV panel production.

There is also the problem with lack of data for estimating public health impacts from transport of the panels to the application sites and transport of maintenance personnel. One could to a first approximation use data from wind turbines in that respect, but there is great uncertainty as both energy conversions will cause very different kinds of impacts. Wind turbines are mechanical machines and as such can cause mechanical damages. This is not the case with non-mobile PV panels that are used as facade elements. On the other hand PV panels can show the effect of islanding, which means that there can be high voltage in parts being maintained by the work crew for several minutes even after the installation has been removed from the grid (Sørensen, 1993, 27). A simple solution to this problem could be to organise maintenance in the night-time, where the solar panels would not produce electricity.

This technology is only in its starting period, so that not much operational experience has been gained with the it. Existing data on accident rates might fall out unfavourably, due to the developmental stage of existing projects. The progression on the learning curve may change figures very much at a larger volume of production and consequently of installed capacity. Further studies are necessary to establish the public and occupational health risk relationships of that technology, to quantify them and to monetize the effects.

### *Economical Considerations*

Currently the PV technology is not being used on a wide scale, a reason for this is that it is not yet economical to generate electricity by grid-connected PV power plants for a utility market. However, already today PV offers economical solutions for certain peak load operations and for decentral installations stand-alone electric power systems, where they are more economical than diesel fuelled generators (WEC, 1994, 89). It can also be expected that PV electricity can be cost competitive for certain peak load operations within the next decades under some assumptions for the cost development for fossil electricity (WEC, 1994, 131 ff.).

In order that PV can be included, in the fair market scenario it has been assumed that economical developments make the diffusion of this technology possible on a wider scale. The ecologically sustainable scenario automatically assumes that PV will be included despite any potential cost disadvantages, and in this scenario the Danish PV share of the electricity generation also is somewhat higher.

### *Heatpumps (HPs)*

Electrically driven heat pumps are being used in both future scenarios to varying degrees. In the fair market scenario most heat demand is provided for by fuel cells, and so heat pumps are only used sporadically. On the other hand in the ecologically sustainable scenario heat pumps are the supporting element for space heat and low temperature process heat supply.

Heat pumps have to comply with the Montreal protocol that leads to the phasing out of substances with an ozone destructive potential (ODP). Other substances will therefore be used as working fluids in the future. As refrigerators now are being filled with substances like pentane, etc., that have very low GWPs and do not lead to ozone destruction it will not be necessary to take any emissions of those substances into consideration for the future scenarios.

There is, however, the question of whether the emissions of such organic compounds, NMVOCs, can enhance the ozone generation in the lower troposphere. We have not explored this point. It would also necessitate the inclusion of nitrous oxide emissions that play an important part in the atmospheric chemistry. Such an analysis is not simple, as the relationships between ozone creation and the atmospheric load of NO<sub>x</sub> and NMVOCs is highly non-linear.

We therefore use the GWPs of R134a and R141b, with the emission factors from their production given in the TEMIS database, GENERIC.PRC:

parameter	value	source	remarks
<b>Technical data</b>		<b>per unit</b>	
spec. invest.	230 ε/kW	Nielsen 1994, 113	
O&M	3 % pa	Nielsen 1994, 113	
capacity	10 kW	GEMIS 1992, 143	
SPF	5	Sørensen <i>et al.</i> 1994, 50	
annual load	1600 h	GENERIC.PRC	el-heatpump-mono
lifetime	20 y	GENERIC.PRC	
lifetime generation	320 MWh		
<b>Material demand</b>		<b>per unit</b>	
Steel	0.4 t	GEMIS 1992, 143	@ 22.2 GJ/t
Plastics	0.26 t	GEMIS 1992, 143	(?)
Concrete (Cement)	0.1 t	guestimate	@ 4.6 GJ/t
FC-R-141b	2 kg	GENERIC.PRC	el-freezer-FC.10
FC-R-134a	0.7 kg	GENERIC.PRC	el-freezer-FC.10

SPF: The seasonal performance factor explains how much heat energy one gains from one unit electrical energy that is input in the heat pump.

## SOFC

Biogas or hydrogen fuelled solid oxide fuel cells are one technology that according to the scenarios will be used to varying degree in the future. The O&M demand is low due to lack of moving parts. On the other hand the demand for the fuel purity is high, and this necessitates the cleaning of the product gas before it can be led into the fuel cell. Fuel cells are a catalysator based electrochemical technology, and the purity of the product gas has to be ensured to prevent clogging of the catalysator, in the same way as unleaded gasoline is essential for use with cars that are equipped with a modern catalysator to clean the exhaust gases.

We have in this study chosen to concentrate on the solid oxide fuel cell technology (SOFC)<sup>9</sup>, as we data for this technology are given in DK-DEA (1995a, 81ff.). This type of fuel cell also is feasible to use in a reversible mode (Morthorst *et al.*, 1993, 15, Sørensen *et al.*, 1994, 35). There is an ongoing development of fuel cells, and progress is being made (Doll, 1995), so that this technology can be expected to become operational on a large scale during the next decades. At the moment, however, it is still in the experimental phase, but has reached some full scale applications in *e.g.* Japan and the U.S., where fuel cell power stations have been built with capacities of several megawatts.

**Table A.27 Future biogas based fuel cell technology data sheet**

parameter	value	source	remarks
<b>Technical data</b>			
	per unit		
spec. invest.	590 ε/kW	DK-DEA 1995a, 83	5-6 Mkr <sub>1994</sub> /MW
O&M	5 % pa	DK-DEA 1995a, 83	
capacity	100 MW <sub>el</sub>	DK-DEA 1995a, 83	range: 15-1000 MW
annual load	5000 h	GENERIC.PRC	
lifetime	20 y	estimate	
lifetime generation	10 TWh		
electrical efficiency	50.0 %	Sørensen <i>et al.</i> 1994, 50	year 2030
thermal efficiency	41.7 %	Sørensen <i>et al.</i> 1994, 50	year 2030
hydrogen efficiency	100.0 %	Sørensen <i>et al.</i> 1994, 50	year 2030
<b>Material demand</b>			
	per unit		spec. energy demand
Electrolyte	250 t	DK-DEA 1995a, 81	YSZ
Anode	250 t	DK-DEA 1995a, 81	Ni and YSZ blend
Cathode	250 t	DK-DEA 1995a, 81	LaMnO <sub>3</sub>
Steel	2500 t	GEMIS 1992, 140	@ 22.2 GJ/t
Concrete (Cement)	6500 t	GEMIS 1992, 140	@ 4.6 GJ/t
Other (aluminium)	750 t	estimated	
<b>Material transport</b>			
	per unit		
steel-truck	200 km	EC 1995/3, 90	
other-truck	200 km	EC 1995/3, 90	
<b>Emissions</b>			
	per MWh <sub>el</sub>		
SO <sub>2</sub>	0	DK-DEA 1995A, 83	
NO <sub>x</sub>	0.1	DK-DEA 1995A, 83	recalculated
particulates	0.1	DK-DEA 1995A, 83	recalculated

hydrogen efficiency: means the efficiency of making hydrogen from electricity input in the reversible heat pump as assumed in Sørensen *et al.* 1994.

**recalculated:** as TEMIS gives data in kg per Terajoule fuel we had to calculate the emissions for the thermal output. The data for material demand of electrolyte, anode and cathode materials are own estimates! In the GEMIS calculation of the externalities they will be substituted by the equivalent weight in aluminium.

<sup>9</sup> Besides solid oxide fuel cells there are also several other types of fuel cells that are currently being investigated: AFC (Alkaline Fuel Cell), PAFC (Phosphoric Acid Fuel Cell), MCFC (Molten Carbonate Fuel Cell), or SPEFC (Solid Polymer Electrolyte Fuel Cell), SPFC (Solid Proton exchange Fuel Cell), DMFC (Direct Methanol Fuel Cell), (IPCC, 1994; Zegers and van de Voort, 1991, in Stimming *et al.*, 1992).



The bearing material of the catalysator can be made from ceramics, while the active material is a rare metal like Platinum. The scarcity and price of such metals have led to research initiatives to find cheaper, and more abundant, alternatives. Such a choice could be a combination of Nickel (Ni) and yttrium-stabilised Zirconium-oxides (YSZ) for electrolyte and anode, and Lanthanum-manganite ( $\text{LaMnO}_3$ ) or strontium doped Lanthanum-manganite ( $\text{LaSrMnO}_3$ ).

With respect to the resource base, Schmidt *et al.* (1994, 22-23) give values for 52 to 116 years for nickel, 900 years for yttrium and 100 years for zirconium. It does, therefore, not seem that those substances are in danger of resource depletion which would compromise widespread use.

As this is a new technology, we can not give any good data on its life cycle impacts nor its externality adders. We note that with respect to the use of catalysators certain elements may exhibit allergic potential and could be released to the environment where they can accumulate. This problem can at the present stage only be identified. Palladium is one example from car catalysators where it increasingly is used to substitute Platinum which, however, is not any longer thought to pose health or environmental problems (Grill, 1996).

Our data overview is as assumed in the scenarios for biogas fuelled fuel cells shown in Table A.27 for the ecologically sustainable scenario. We have assumed that the biogas for this type of technology necessarily will have to be cleaned so that  $\text{SO}_2$  emissions are negligible. Table A.28 shows the data for the fuel cells used in the fair market scenario.

**Table A.28 Future hydrogen based reversible fuel cell technology data**

parameter	value	source	remarks
<b>Technical data</b>	<b>per unit</b>	see Table A.27	
electrical efficiency	62.0 %	Nielsen&Sørensen 1996, 109	year 2050
thermal efficiency	28.0 %	Nielsen&Sørensen 1996, 109	year 2050
hydrogen efficiency	90.0 %	Nielsen&Sørensen 1996, 109	year 2050
<b>Material demand</b>	<b>per unit</b>	see Table A.27	
<b>Emissions</b>	<b>per MWh<sub>el</sub></b>		
$\text{SO}_2$	0 g	DK-DEA 1995A, 83	
$\text{NO}_x$	0.1 g	DK-DEA 1995A, 83	recalculated
particulates	0.1 g	DK-DEA 1995A, 83	recalculated

hydrogen efficiency: means the efficiency of making hydrogen from electricity input in the reversible heat pump.  
**recalculated:** as GEMIS gives data in kg per Terajoule fuel we had to calculate the emissions for the thermal output. The data for material demand of electrolyte, anode and cathode materials are own estimates! In the GEMIS calculation of the externalities they will be substituted by the equivalent weight in aluminium.

Quoting Morthorst *et al.* (1993, 38) on the hydrogen electrolysis efficiency, they have given a value of 94 per cent efficiency (with a range of 80 to 90 % for today's technologies), which compared to the values given in our tables above is somewhat lower than for the ecologically sustainable scenario but somewhat higher than for the fair market scenario.

Fuel cells will in the start of their commercial career be installed as centralised units with larger capacities and first later on probably become smaller in generation size so that they can be installed in decentralised units. This also is our reason for assuming low  $\text{SO}_2$  emissions from this technology, despite the fact that biogas, as assumed to be used as a fuel in the ecologically sustainable scenario, contains rather large amounts of sulphur.

#### *H2mot*

Smaller hydrogen fired CHP engines (for decentralised heat and power) will exclusively be used in the fair market scenario to cogenerate electricity and heat, mostly as a back up technology.

Due to the high combustion temperatures nitrogen oxides are produced. Regulations that prescribe maximum emissions might conflict with the development of this technology. The small size makes it costly to clean the exhaust fumes from nitrogen oxides in order to reach the values demanded by the knowledge of the critical loads of natural systems.

Engines are rather work intensive, and they cause vibration and noise problems. This technology might therefore in fact be substituted by small scale fuel cell technologies under development today (see under SOFC). We use data from DK-DEA (1995a, 34ff.) and also note that the efficiencies originally given in the fair market scenario are somewhat lower than what we can actually expect. This is indicated in the data sheet table.

**Table A.29 Hydrogen fuelled motor CHP data sheet**

parameter	value	source	remarks
<b>Technical data</b>		<b>per unit</b>	
spec. invest.	590 ε/kW	DK-DEA 1995a, 36	5-6 Mkr <sub>1994</sub> /MW in 2005
O&M	5 % pa	DK-DEA 1995a, 36	range 5-10 for 2005
capacity	0.1 MW <sub>th</sub>	DK-DEA 1995a, 36	range: 0.02-5 MW
annual load	5000 h	GENERIC.PRC	gas-BPS-th-cat-sm
lifetime	25 y	DK-DEA 1995a, 36	
lifetime generation	12.5 GWh		
electrical efficiency	31.25 %	Nielsen&Sørensen 1996, 109	year 2050
thermal efficiency	50.0 %	Nielsen&Sørensen 1996, 109	year 2050
electrical efficiency	42.0 %	DK-DEA 1995a, 36	<b>already in 2015!</b>
thermal efficiency	52.0 %	DK-DEA 1995a, 36	<b>already in 2015!</b>
<b>Material demand</b>		<b>per unit</b>	
Steel	500 kg	GENERIC.PRC	spec. energy demand @ 22.2 GJ/t
Concrete (Cement)	500 kg	GENERIC.PRC	@ 4.6 GJ/t
Copper	50 kg	GENERIC.PRC	
Other (aluminium)	75 kg	estimated	
<b>Material transport</b>		<b>per unit</b>	
steel-truck	200 km	EC 1995/3, 90	
other-truck	200 km	EC 1995/3, 90	
<b>Emissions</b>		<b>per MWh<sub>th</sub></b>	
SO <sub>2</sub>	0 g	GEMIS 1992, 117	
NO <sub>x</sub>	330 g	GEMIS 1992, 105	recalculated
particulates	8.9 g	GEMIS 1992, 105	recalculated
N <sub>2</sub> O	8.9 g	GEMIS 1992, 105	recalculated

Hydrogen motors are not yet being used in a wide scale today, although they should be somewhat cheaper to build than natural gas or gasoline fired motors and have other advantages, too (Veziroglu, 1989, 434f.). The particles stem from lubricants and losses of the catalysator materials, hydrogen itself is free of mineral dust.

**recalculated:** as GEMIS gives data in kg per Terajoule fuel we had to calculate the emissions for the thermal output.

### Hydropower

Hydropower is being assumed to play a little role for Denmark's present energy system but electricity is imported from Norway in periods of surplus production in that country. Hydro-power externalities are described in the ExternE project (EC, 1995/6), but the emissions of methane<sup>10</sup> from the artificial lakes needed for large scale hydro power exploitation, as assessed by Rudd *et al.* (1993), have not been included.

However, we have chosen not to use the value given in Rudd *et al.* (1993) directly, rather we follow the approach of Rosa and Schaeffer (1994). They have estimated the CO<sub>2</sub> and CH<sub>4</sub> emissions, determined their cumulative heating effects, and given them in carbon equivalents<sup>11</sup>.

<sup>10</sup> an important greenhouse gas

<sup>11</sup> The authors are not very clear about this, but we assume that they mean CO<sub>2</sub> equivalents.

This approach is similar to another one by Hammit *et al.* (1996), who try to estimate an economical impact index of global warming<sup>12</sup>. The data look as following:

**Table A.30 Equivalent CO<sub>2</sub> emissions for hydroelectric reservoir dams**

reservoir type	energy density TWh y <sup>-1</sup> km <sup>-2</sup>	MtC y / TWh y <sup>-1</sup> over 50 ys	MtC y / TWh y <sup>-1</sup> over 100 ys	g CO <sub>2</sub> / MWh over 100 years
high energy density	0.011	0.23-0.27	0.18-0.20	17000-19000
low energy density	0.001	1.84-2.20	1.48-1.84	140000-175000
fossil power plants		2.40-5.90	4.25-10.42	403000-990000

**Bold data** show integrated radiative forcing over 100 years calculated from the equivalent carbon emissions given by Rosa and Schaeffer 1994.

MtC yr/TWh yr<sup>-1</sup>: this is the integrated radiative forcing equivalent to an emission of CO<sub>2</sub> over the 50 or 100 year period compared to the yearly production of one terawattour<sup>13</sup>.

high energy density: dams in regions with high relief energy and consequently low area demand.

low energy density: dams in regions with little relief energy and consequently high area demand.

We can assume that the Canadian data from the approach by Rudd *et al.*, scrutinised by Rosa and Schaeffer (1994), are valid for Norwegian hydropower, too. For Swedish hydropower dams Stjernquist (1986, 179) gives a value of 12 km<sup>2</sup> per TWh and year (=0.09 TWh y<sup>-1</sup> km<sup>-2</sup>), so we impose a CO<sub>2</sub> emission of 18,000 grams per megawattour as a result of greenhouse gas emissions from biomass decomposition in the hydropower reservoirs.

**Table A.31 ExternE hydropower data sheet**

parameter	value	source	remarks
<b>Technical data</b>		<b>per unit</b>	
spec. invest.	860 ε/kW	EC 1995/6, 140	310 MECU
O&M	5 % pa	EC 1995/6, 140	
capacity	360 MW	EC 1995/6, 140	
annual load	3500 h	EC 1995/6, 140	
lifetime	50 y	EC 1995/6, 140	
lifetime generation	63 TWh		
<b>Material demand</b>		<b>per unit</b>	
Steel	200000 t	EC 1995/6, 139	spec. energy demand
Copper	2000 t	estimate	
Concrete (Cement)	960000 t	EC 1995/6, 139	
<b>Material transport</b>		<b>per unit</b>	
steel-truck	200 km	EC 1995/3, 90	
concrete-truck	50 km	EC 1995/3, 90	
copper-truck	200 km	EC 1995/3, 90	

Copper: the amount of copper is estimated to be one per cent of the steel weight.

### *Tropical hydropower*

For the hydropower used for material extraction or *e.g.* for alumina production, see in the section on aluminium production below, we apply the higher value of 150,000 g per megawattour.

### *DH&storage*

District heating systems beside the very transmission system in this context also imply heat storage systems to phase out seasonal or daily and weekly differences between heat supply and

<sup>12</sup> There has been a consequent discussion on the methodology used by Hammit *et al.* (1996) on the question of social cost discounting; see Caldeira (1996) and Hammit *et al.* (1996a). Discounting can be seen as a bi-sided sword: it can prevent mitigative actions today, or it can argue for them today. It depends on the discount rate chosen by the investigators.

<sup>13</sup> Our approach is a linear one in that we calculate that the emissions would occur equally over the life time of the installation. As Rosa and Schaeffer have pointed out, this is actually not the case in reality, but we cannot use a more advanced approach in the GEMIS program anyway.

demand. We can assume that for all these systems indirect effects from their production will have the biggest importance with regard their life cycle costs.

**Table A.32 Tropical hydropower installation data sheet**

parameter	value	source	remarks
<b>Technical data</b>		<b>per unit</b>	
spec. invest.	860 €/kW	EC 1995/6, 140	310 MECU
O&M	5 % pa	EC 1995/6, 140	
capacity	1000 MW	GENERIC.PRC	Hydro-PP-CIS
annual load	3500 h	GENERIC.PRC	
lifetime	50 y	EC 1995/6, 140	
lifetime generation	175 TWh		
<b>Material demand</b>		<b>per unit</b>	
Steel	40000 t	GENERIC.PRC	spec. energy demand
Copper	8000 t	estimate	
Concrete (Cement)	2000000 t	GENERIC.PRC	
<b>Material transport</b>		<b>per unit</b>	
steel-truck	200 km	EC 1995/3, 90	
concrete-truck	50 km	EC 1995/3, 90	
copper-truck	200 km	EC 1995/3, 90	

Copper: the amount of copper is estimated to be two per cent of the steel weight.

**Table A.33 DH technology data**

parameter	value	source	remarks
<b>Technical data</b>		<b>per unit</b>	
			<b>DH</b>
capacity	100 MW <sub>th</sub>	GEMIS 1992, 142	
utilisation	5000 h	GENERIC.PRC	
lifetime	30 y	GENERIC.PRC	DH-from-gas-CC
lifetime generation	15 TWh <sub>th</sub>		
efficiency	80.2 %	Sørensen <i>et al.</i> 1994, 48	<b>today</b>
efficiency	75.4 %	Sørensen <i>et al.</i> 1994, 50	<b>2030</b>
efficiency	75.0 %	Nielsen&Sørensen 1996,109	<b>2050</b>
<b>Material demand</b>			
Steel	1300 t	GEMIS 1992, 142	
PU (plastic)	50 t	GEMIS 1992, 142	
Cement	100 t	GEMIS 1992, 142	
<b>Process demand</b>		<b>per MWh<sub>th</sub></b>	
electricity	0.015	GENERIC.PRC	

That the efficiency of the DH system should be lower in the future can be explained by the introduction of seasonal storage losses in a general way: Sørensen *et al.* 1994. Nielsen and Sørensen 1996 do, however, mention a separate system of seasonal storage tanks for warm water solar heat.

With respect to seasonal heat storage there are currently two technologies proposed in Denmark, and both can be perceived to play a role in the future. We concentrate here on water mass storage tanks without phase changes, and give later another example of a phase change technology that could prove viable in the future. Welded steel tanks with an outward insulation from mineral wool or other materials are one technology. Lawaetz (1993) gives some examples for current (1992) estimates for medium and large size examples.

There is already one example of a small size tank established in Herlev in Denmark (Olesen, 1996) that currently is under repair. It was found that the biggest problem with this technology is the stability and the durability of the coating<sup>14</sup>. For a continuing development in this area the prices for steel tanks and another technology investigated today, earth basins, have to come down to

<sup>14</sup> Actually the Herlev demonstration project is a concrete basin filled out with a plastic foil, and the latter has become broken. There are plans to use a Swedish product, a plastic-metal foil, that should better be able to stand the high temperatures. PU foam does not keep its qualities under the high temperatures (Olesen, 1996).

about 300 Dkr (34.6 ECU) per cubic metre, and a long term limit could be around 23 ECU or slightly less (Olesen, 1996).

Earth basins are simply an excavation in the ground that is sealed with clay. On the top an insulating layer is applied. However, there is no insulation in the bottom and at the side walls, thereby the ground is used as a thermal mass, too (Wesenberg *et al.*, 1991). This increases heat losses to about 30 per cent between summer and winter for middle sized storage systems (Olesen, 1996), which is exactly the same value as used in the scenario texts.

In any case a proper exergy<sup>15</sup> analysis is necessary, as the amount of heat energy that can be recovered not in all cases actually has the quality that one needs for the various purposes. Krane (1989) and Hahne *et al.* (1989) describe the necessity to perform such an analysis. One advantage of applying this technique is the result that by layering of the water masses instead of mixing them during the charge period the total exergy of the medium is kept high, but it has to be ensured that the layering is not perturbed by movements of the water masses under charging and discharging activities.

**Table A.34 Properties of some chosen sensitive and latent heat media**

medium	melt. pnt. C	density kg m <sup>-3</sup>	spec. heat J kg <sup>-1</sup> K <sup>-1</sup>	fusion heat J kg <sup>-1</sup>	heat capac. J m <sup>-3</sup> K <sup>-1</sup>	th. conduct. W m <sup>-1</sup> K <sup>-1</sup>	th. diffus. m <sup>2</sup> s <sup>-1</sup>
water		1000	4190				0.63 @38C
earth (wet)		1700	2093		3558100	2.51	0.705
earth (dry)		1260	795		1001700	0.25	0.250
<i>CaCl<sub>2</sub>·6H<sub>2</sub>O</i>	28	1634		177000			
<i>Na<sub>2</sub>S<sub>2</sub>O<sub>3</sub>·5H<sub>2</sub>O</i>	48	1666		209000			

Source: (Kakaç *et al.* 1989, 139).

*Italics: phase change materials and only non-toxic materials have been listed.*

#### Phase change heat storage

Another promising technology are phase change energy storage systems. The basic principle here are phase changes of a working medium, whereby the compared to thermal changes larger latent heat changes (see Table A.34 and Table A.35) are exploited. Their big advantage compared to sensible heat storage systems is the small volume of such systems, as illustrated in Table A.35. Solid liquid phases changes are the easiest to work with. A disadvantage with this technology is the, compared to liquid-gas phase changes, a smaller amount of latent heat that can be stored, respectively recovered, per unit volume of the working medium but on the other hand volume changes are not as marked.

**Table A.35 Storing one gigajoule heat with water and Na<sub>2</sub>SO<sub>4</sub>(H<sub>2</sub>O)<sub>5</sub>**

material	density kg m <sup>-3</sup>	spec. heat J kg <sup>-1</sup> K <sup>-1</sup>	heat of reaction kJ kg <sup>-1</sup>	mass kg	volume m <sup>3</sup>
water	1000	4190		23870	23.87
Na <sub>2</sub> SO <sub>4</sub> ·10H <sub>2</sub> O	1458	1960	251	3695	2.53
Na <sub>2</sub> SO <sub>4</sub> ·10H <sub>2</sub> O+H <sub>2</sub> O	1274		244	*4096	*3.22

Source Kakaç *et al.* 1989, 152.

\*: does not include the contribution from specific heat.

Several paraffins and some solutions of inorganic salts in water also offer phase change reactions, but their stability has still to be proven. Furthermore some of the promising compounds are either toxic or corrosive. The first problem means that the system has to be contained securely, and the latter problem is still to be solved with respect to a heat resistant foil (Kakaç *et al.*, 1989, 153). Because of these reasons we do not take into consideration phase change systems in our

<sup>15</sup> The amount of useful energy provided by the system.

study but do mention this technology, as it has the stated advantages and could become an accepted future technology.

Besides the occupational and public health impacts of the construction of the storage facilities there is one problem left: the analysis of the insulation material used for the walls of steel tanks and the roof constructions of those and earth basin heat storage. We refer to the relevant paragraph in the materials section.

The smaller energy demand during production and temperature stability point toward the perlite and the granulate products. We will therefore in our study calculate with perlite and granulate products as wall and roof insulation materials in heat storage installations and in part for domestic insulation practices for the future scenarios.

The data sheet for the heat storage is based on the earth dam technology, as given in Wesenberg *et al.* (1991).

**Table A.36 Heat storage data sheet**

parameter	value	source	remarks
<b>Technical data</b>		<b>per unit</b>	<b>Storage</b>
capacity	2 MW	Wesenberg <i>et al.</i> 1991, 6	computed
utilisation	4000 h	guestimate	
volume	100000 m <sup>3</sup>	Wesenberg <i>et al.</i> 1991, 50	
removed earth volume	40000 m <sup>3</sup>	Wesenberg <i>et al.</i> 1991, 50	
lifetime	30 y	estimate	
price ECU m <sup>-3</sup>	37	estimate, 1992	
price ECU m <sup>-3</sup>	24	guestimate for the future	
<b>Material demand</b>			
Concrete tiles	1000 m <sup>3</sup>	Wesenberg <i>et al.</i> 1991, 50	10 cm, p.41
Geotextile foil	10800 m <sup>2</sup>	Wesenberg <i>et al.</i> 1991, 50	
2mm HDPE foil	10800 m <sup>2</sup>	Wesenberg <i>et al.</i> 1991, 50	
Fibre concrete	100000 m <sup>3</sup>	Wesenberg <i>et al.</i> 1991, 50	
Plastics	64 t	Wesenberg <i>et al.</i> 91: 71,81	from given data
Clay	24000 t	Wesenberg <i>et al.</i> 1991, 61	
Concrete (Cement)	5000 t	guestimate	2.24 t m <sup>-3</sup>
Steel	3 t	Wesenberg <i>et al.</i> 1991, 61	
Insulation material	1 t	Wesenberg <i>et al.</i> 1991, 61	0.2 m @ 0.2 t m <sup>-3</sup>
<b>Material transport</b>		<b>per unit</b>	
clay-truck	30 km	Wesenberg <i>et al.</i> 1991, 61	
steel-truck	200 km	EC 1995/3, 90	
concrete-truck	50 km	EC 1995/3, 90	
others-truck	150 km	EC 1995/3, 90	
others-railway	50 km	EC 1995/3, 90	

The plastics weight is computed by assuming 5 mm Geotextile (bentonite) foil and 2 mm HDPE foil.

For computational reasons the insulation material is assumed to be polystyrene, which is the generic plastic material in TEMIS.

#### *transmission*

Transmission grids are necessary to be able to transport the electricity to the consumers. We have not assessed the direct impacts from electricity transmission and distribution. We do note, though, that transmission lines have been made responsible for various health impacts, there is an ongoing discussion of that question. There certainly are the visual impacts of aboveground installations. Accidents occur during mounting and maintenance of power lines. Indirect impacts arise from the materials used in transmission equipment. However, we also estimate those impacts to be of minor importance compared to the ones of other technologies. There also is an option arising from developments of super conducting materials that would minimise magnetic fields from such transmission lines.

Tande *et al.* (1996, 19) and Jørgensen *et al.* (1996, 43) give some data on the square area of three current 10 kV cables inclusive price examples:

**Table A.37 Various cable data**

parameter	value	source	remarks
voltage	10 kV	Jørgensen <i>et al.</i> 1996, 19	<b>Transmission</b>
price	165000 kr/km	Tande <i>et al.</i> 1996, 19	50 mm <sup>2</sup> AL PEX
current intensity	136 A	Jørgensen <i>et al.</i> 1996, 43	50 mm <sup>2</sup> AL PEX
price	205000 kr/km	Tande <i>et al.</i> 1996, 19	95 mm <sup>2</sup> AL PEX
current intensity	206 A	Jørgensen <i>et al.</i> 1996, 43	95 mm <sup>2</sup> AL PEX
price	250000 kr/km	Tande <i>et al.</i> 1996, 19	150 mm <sup>2</sup> AL PEX
current intensity	265 A	Jørgensen <i>et al.</i> 1996, 43	150 mm <sup>2</sup> AL PEX

When these data are used in the computation it is due to the following considerations. Although electricity cables currently normally are air connections it has in the latter years become common practice in Denmark to bury transmission lines in the ground. Partly for aesthetic and partly for psychological reasons, as air transmission lines have been connected to possible health damages. Conclusive prove for the latter seems not to have been found yet. If in the future super conducting cables will be used on a wide scale than the possible health impacts from magnetic fields from transmission lines will be excluded because of physical reasons.

The data in GEMIS (1992) have been used, with the exception of aluminium that we assume is used for transmission cables.

**Table A.38 Data for current transmission and distribution**

parameter	value	source	remarks
<b>Technical data</b>			<b>current technology</b>
capacity	1000 MW	GEMIS 1992, 140	<b>Transmission</b>
distance	1000 km	GEMIS 1992, 140	
<b>Material demand</b>			
Steel	400000 t	estimate	sum of steel and aluminium gives total steel GEMIS value
Aluminium	225000 t	estimate	
Cement	31250 t	GEMIS 1992, 140	
<b>Technical data</b>			<b>future technology</b>
capacity	1000 MW	GEMIS 1992, 140	<b>Transmission</b>
distance	1000 km	GEMIS 1992, 140	
<b>Material demand</b>			
Aluminium	425000 t	estimate	sum of aluminium and plastic gives total steel GEMIS value
Plastics	200000 t	estimate	
Cement	31250 t	GEMIS 1992, 140	
capacity	100 MW	GEMIS 1992, 140	<b>Distribution</b>
distance	10 km	GEMIS 1992, 140	
<b>Material demand</b>			
Steel	45000 t	GEMIS 1992, 140	
Cement	4500 t	GEMIS 1992, 140	

### *pipeline*

Pipelines are currently being used to transport natural gas to the consumers. They will in the future scenarios also be applied to the transport of biogas and hydrogen. We have assumed that the technology is the same for all three energy carriers. Even though there are some differences with regard these gases, for example hydrogen is much more volatile due to its small molecule diameter. In Denmark gas transmission pipelines fulfil the standards necessary for any possible future use of hydrogen instead of natural gas.

On the distribution nets in towns Morthorst *et al.* (1993, 13) mention that town gas, that contains 50 % hydrogen, has been distributed in those systems before, apparently without any large problems. We also have to mention that some of the hydrogen technologies will probably not require material transport, as for example reversible fuel cells will probably be equipped with storage tanks to use the hydrogen, and if also stored the oxygen from the electrolysis, when there will be a heat or electricity demand.

Impacts are therefore stemming from the materials and any liberation of the transported gases from leakages or accidents. Biogas and natural gas emissions have to be avoided as both gases have high a GWP. We assume that transport losses from pipeline transport to the air are 0.6 per cent, as described in Isaksen and Roland (1990, 66). This value is slightly higher than the 0.5 % losses proposed for a 400 km pipeline transport of Morthorst *et al.* (1993, 13), and so our value is a little bit more conservative in that respect.

With regard to pipeline failures we can only quote Taylor's (1994, 398) data. He notes that pipelines with larger diameters will have smaller incidence rates and cites a value of 5 E-4 per kilometre and year as a suitable estimate, with 87 % of the failures being small, 10 % medium and 3 % large or catastrophic in size. For natural gas pipelines failure rates are little higher, 6.5 E-4. The same distribution in the three classes apply. Taylor states that a small hole (<20 mm) can only with difficulty support a high pressure jet flame, unless it impinges.

**Table A.39 Pipeline data**

parameter	value	source	remarks
<b>Technical data</b>			
capacity	1000 MW	GENERIC.PRC	Pipeline\gas-NOR
annual load	6000 h	GENERIC.PRC	
lifetime	25 y	GENERIC.PRC	
length	600 km	estimate for Denmark	
<b>Material demand</b>			
Steel	300000 t	GENERIC.PRC	
<b>Transport energy demand MJ/tkm</b>			
compressor power	0.06	GENERIC.PRC	
<b>Emissions per MWh</b>			
CH <sub>4</sub>	453 g	estimate	for natural gas or biogas pipelines and storage systems

Another necessary technology used in the fair market scenario is a hydrogen storage to even out production and consumption unbalances. Morthorst *et al.* (1993, 38) give some data on this technology, but they are not sufficient to estimate the probable impacts, Table A.40.

**Table A.40 Gas storage technical data**

Storage	Efficiency	Lifetime	Spec. investment	Annual O&M costs
Cavem	99 %	30 y	34.6 ECU m <sup>3</sup>	1.6 % of investment

Source: Morthorst *et al.* 1993, 38.

Note: we have calculated with 1990 prices as indicated.

One should perform a risk analysis of this technology, but we do not have the necessary data to do this. We can therefore not estimate how large the danger potential from accidents might turn out to become and whether it presents a potentially important impact on the full costs of *e.g.* the export oriented fair market scenario, where hydrogen has to be stored and transported on a larger scale.

Following Taylor (1994, 369) we can conclude that hydrogen stores should not pose much larger risks than refineries or ammonia plants where the substance that may escape is poisonous. Hydrogen is very volatile, so that rapid dilution would reduce explosion danger. Data on the risks



related to natural gas storage plants would probably also be representative for hydrogen storage, and be similar to interpret as indicated by Taylor (1994, 386).

However, Morthorst *et al.* (1993, 22) mention hydrogen's wide range of inflammability, a low ignition energy and a large range of mixture area for explosivity as important factors for a risk assessment. In any case it has to be ensured that hydrogen and oxygen (for reversible fuel cells with separate stores for the two resultants from the electrolysis) are kept apart. Another problem is that hydrogen can cause brittleness in various metals, so that different alloys will have to be employed compared to today's natural gas technologies.

## Non-Electric Primary Energy Sources

### Biomass production

Biomass production is related to current and conceivable future agricultural technologies. At present most agriculture in Denmark is so-called traditional and uses many chemical and energy inputs. Some farmers have started to grow organic crops and do not rely on chemical products to fight off pests or weeds. There have also been attempts to use integrated farming methods that would still allow use of fertilisers and biocides, but only during acute pest attacks, not as in traditional farming preventively. Other sources of biomass are residues from agricultural and some industrial production, like slurry from animal husbandry and wastes from paper and pulp manufacturing.

#### *bioplant*

One example of biomass from centralised biomass plantations is wood chips with an estimated total Danish potential of 3 to 21 PJ yearly (Nielsen *et al.*, 1994, 39).

#### *Elementary Analysis*

To give a short example we present an example of a typical biomass resource, wood chips:

**Table A.41 Elementary analysis of wood chips**

Species	Weight %	Range
carbon	50	
oxygen	43	
hydrogen	6	
nitrogen	0.2	0.04-0.25
sulphur	0.003	
ash	0.8	0.1-1
volatiles	75	70-80
LHV (GJ/t)	15	8-21 GJ/t

(Source: Formidlingsrådet 1989, 42 f.).

#### *Energy Input-Output Relations*

Data for input-output ratios<sup>16</sup> for biomass from energy plantations or dedicated energy crops, like rape, lucerne or sugar-beets, can be found in *e.g.* Johansson (1995), Börjesson (1996a) or Formidlingsrådet (1989). Table A.42 shows values for several possible crops to show that there is a large span in the results.

<sup>16</sup> The input output ratio means the amount of energy harvested divided by the energy input and so is unit-free.

**Table A.42 Input-output ratios of biomass production**

Species	1990	2015	Source
Winter-wheat only grains	5.2	7.0	Börjesson 1996a, 13
Winter-wheat	6.7	8.2	Börjesson 1996a, 13
Winter-rape only seeds	4.4	5.1	Börjesson 1996a, 13
Winter-rape	6.2	9.2	Börjesson 1996a, 13
Potato	3.0	4.6	Börjesson 1996a, 13
Sugar-beet	7.0	7.2	Börjesson 1996a, 13
Clover	11	11	Börjesson 1996a, 13
Lucerne	14	15	Börjesson 1996a, 13
Reed canary grass	11	14	Börjesson 1996a, 13
Salix	21	26	Börjesson 1996a, 13
Winter-wheat	9	?	Nielsen <i>et al.</i> 1994, 41
Winter-wheat only grains	11	?	Nielsen <i>et al.</i> 1994, 41
Winter-wheat only straw	75	?	Nielsen <i>et al.</i> 1994, 41
Winter-barley	9	?	Nielsen <i>et al.</i> 1994, 41
Winter-rape	8	?	Nielsen <i>et al.</i> 1994, 41
Salix	17	?	Nielsen <i>et al.</i> 1994, 41
Miscanthus	17	?	Nielsen <i>et al.</i> 1994, 41

The data for 2015 from Börjesson 1996a are based on biomass energy inputs.

From Börjesson (1996a, 13) we extract the following more detailed data for typical biomass production today or in the future. The resources we have chosen represent the current production mix of Danish agriculture for sugar beet, rape and clover, and for likely new products with an increasing market share in the future as lucerne and willow.

**Table A.43 Energy yields, primary energy inputs, net energy yields for present and estimated future production conditions for various energy crops.**

Biomass resource	Sugar beet today	Sugar beet 2015	Willow today	Willow 2015	Rape total today	Rape total 2015	Clover today	Clover 2015	Lucerne today	Lucerne 2015
Motor fuels	15	19	2.1	2.3	5.7	6.1	5.5	8.9	5.7	9.7
Seeds	0.23	0.24	0.30	0.34	0.24	0.27	0.74	0.74	0.45	0.46
Fertilisers, etc	6.7	7.2	4.3	5.6	8.4	9.3	3.8	4.0	1.0	1.1
Biocides	0.16	0.12	0.02	0.02	0.20	0.15	0.09	0.06	0.09	0.06
Machinery	1.8	1.7	0.41	0.39	2.2	2.0	0.85	0.83	0.85	0.83
Mach. transp.			0.03	0.05						
Biom. transp.	3.1	5.1	1.3	3.0	0.50	0.72	2.2	4.2	2.4	5.6
<b>Total</b>	<b>27.0</b>	<b>33.4</b>	<b>8.4</b>	<b>12.1</b>	<b>17.2</b>	<b>18.5</b>	<b>13.2</b>	<b>18.7</b>	<b>10.5</b>	<b>15.8</b>
<b>Energy yield</b>	<b>190</b>	<b>240</b>	<b>180</b>	<b>330</b>	<b>70</b>	<b>86</b>	<b>140</b>	<b>200</b>	<b>150</b>	<b>270</b>
<b>Net Yield</b>	<b>163</b>	<b>207</b>	<b>172</b>	<b>317</b>	<b>88.8</b>	<b>104</b>	<b>127</b>	<b>181</b>	<b>140</b>	<b>252</b>
<b>O/I ratio</b>	<b>7.0</b>	<b>7.2</b>	<b>21</b>	<b>26</b>	<b>6.2</b>	<b>6.6</b>	<b>11</b>	<b>11</b>	<b>14</b>	<b>15</b>
<b>Chosen</b>	<b>liquid</b>	<b>liquid</b>	<b>biogas</b>	<b>biogas</b>						

2015: these data are given for methanol fuelled machines.

All data, except O/I, given in GJ per hectare and year.

Biom. transp.: transport 50 kilometres by truck.

As can be seen the output input ratio can be very large for dedicated energy plantations, but the area applicable for them will be restricted by the demand for food products that shall still be produced. It can be expected that import of food and fodder will be reduced in the future as a result of ethical and commercial deliberations as well as from changes in diet. As willow is the most promising biomass crop it will be chosen for biomass and biogas energy production from plantations. We give also data for sugar beet production as an example for liquid biofuels due to its high energy yield per hectare (Hall, 1994, 189).

The amount of energy needed in harvesting or planting depends on a range of parameters which have been described more thoroughly in NE (1983). There is a danger of underestimations, and

too optimistic assumptions have been made with regard the planting rate of willow cuttings (NE, 1983, 15). It might in places be necessary to eradicate existing plant cover, e.g. rhizomous grasses, with chemical herbicides as glyphosate.

#### *Rotation and Installation*

A biomass plantation consists of the installation phase, with soil preparation and planting, crop protection and finally harvesting. One *rotation* means the time between sprouting and harvesting for an established biomass plantation, or between installation or planting and harvesting for new plantations.

Starting with the installation, the National Swedish Board for Energy Development (1983, 26) gives figures on the average work input for planting heads<sup>17</sup>. Figures for this activity range from 0.4 to 0.6 hectares per hour at a planting density of 4400 to 35 000 stems or heads per hectare. In Meyer *et al.* (1994, 61) an example is given of a possible Danish biomass plantation with 18 to 20 thousand stems per hectare. As shown in Table A.44 the work amount for harvesting mini rotation willow plantations is about 1.67 hours per hectare, it should be about the same for a midi rotation. We use this data later in the calculation of the fatality rates in biomass production.

**Table A.44 Typical data for biomass plantations**

Basic data	Activity	Figure	Remark	Source
stems per hectare	planting	4400-35000	midi-mini rotation plantations	(1)
stems per hour	planting	2666-14000	midi-mini rotation plantations	(1)
vehicle speed (km h <sup>-1</sup> )	planting	1.8-2	mini-midi rotation plantations	(1)
work hours per hectare	planting	1.65-2.5	midi-mini rotation plantations	(1), (0)
power consumption kW	planting	25		(1)
energy demand GJ ha <sup>-1</sup>	planting	0.15-0.23	midi-mini rotation plantations	(1)
vehicle speed (km h <sup>-1</sup> )	harvesting	3	mini rotation plantations	(1)
work hours per hectare	harvesting	1.67	mini rotation plantations	(1), (0)
power consumption kW	harvesting	75	mini rotation plantations	(1)
energy demand GJ ha <sup>-1</sup>	harvesting	0.45	mini rotation plantations	(1)

Sources: (1) NE 1983: 26, 33; (0) own calculations.

*Italics: own calculation.*

mini rotations: 2 years between harvest (1).

midi rotations: 4 to 5 years between harvest (1), (2).

#### *Occupational Impacts*

There are not many data available on the occupational impacts of biomass production, but, as for coal mining, accident rates might be an important factor to consider.

From investigations on risk potential Starr (1976, 25f) mentions a nearly constant fatality rate of about  $4 \cdot 10^{-7}$  per hour of farm tractor use for the period 1920 to 1970 despite the fact that the farming device industry has made efforts to increase safety of tractors. "If you build a better farm machine that's safer, the farmer will now use it more drastically.", might explain this constancy in fatality rate per hour of exposure.

Starr (1976, 24) also gives data on the fatality rates in general aviation. We have to take this into consideration as according to Nonhebel (1995, 18) due to the large heights, up to 4 metres, that most biomass crops reach before coppicing, *i.e.* harvesting the sprouts and thin stems, it is not always feasible to apply biocides from the ground. Therefore the use of aircrafts will become necessary after some time from planting. We assume that about half the crop protection will have to be done from aircraft, Table A.46. The energy demand for both activities is comparable<sup>18</sup> the

<sup>17</sup> rods of e.g. willow that grow into plants, possibly in the form of wood-grass (Shen, 1988).

<sup>18</sup> She gives a difference of 30 MJ ha<sup>-1</sup> in favour of the aircraft: 120 instead of 150 MJ ha<sup>-1</sup>.

accident rates, however (Starr, 1976, 24), are not. The last point has to be seen in relation to the time necessary for treating one hectare, as shown in Table A.45.

**Table A.45 Fatality rates for tractors and general aviation**

Transport Mode	Activity	Figure	Remark	Source
tractors	crop protection	4 E-7	fatalities per work hour	(4)
general aviation	crop protection	1 E-5	do.	(4)
tractors	crop protection	0.5 h	time demand for 1 ha	(2)
general aviation	crop protection	0.017 h	do.	(2)

Source: (2) Nonhebel 1995: 17f, (4) Starr 1976: 19, 25.

It also has to be remembered that application rates of nitrogen fertiliser are limited as osmotic damage in the crop has to be avoided. Nonhebel (1995, 17f.) therefore assumes application rates of 300 kg N for about seven times, *i.e.* 2100 kg N, per coppicing cycle in very intensive agriculture in Southern Europe. Meyer *et al.* (1994, 103) only apply about a fourth of this value, *i.e.* 490 kg N, for the Danish situation, so we have used this value for the fertiliser application with the equivalent application rates from Nonhebel. This also prevents nitrogen leaching as the young sprouts *e.g.* after coppicing cannot take up all the available nitrogen. On the question of N<sub>2</sub>O emissions we refer to a later paragraph.

In Table A.46 we have assembled our assumptions to estimate values for fatalities and two other accident categories. Our value of 0.06 10<sup>-10</sup> fatalities per megajoule of harvested willow is smaller than the 2.1 10<sup>-10</sup> per MJ wood<sup>19</sup> given by ORNL and RFTF (1992b, 7-21). Even though they only have included accidents from tree cutting we assume that mechanised harvesting will lead to lower accident rates, as manual tree cutting is acknowledgedly a very dangerous activity.

**Table A.46 Data for willow production**

Incident type	Activity	Figure	Remark	Source
fatalities per hectare	planting	1.0 E-6	once per installation 2.5 h	(4), (2), (5), (0)
fatalities per hectare	harvesting	5.3 E-6	eight times 1.67 h	(4), (2), (5), (0)
fatalities per hectare	N-fertilising	1.4 E-6	14 times 0.25 h	(4), (2), (5), (0)
fatalities per hectare	P-fertilising	0.1 E-6	once per installation 0.25 h	(4), (2), (5), (0)
fatalities per hectare	K-fertilising	0.2 E-6	2 times 0.25 h	(4), (2), (5), (0)
fatalities per hectare	crop protection	9.6 E-6	48 times 0.5 h <b>tractor</b>	(4), (2), (0)
fatalities per hectare	crop protection	8.0 E-6	48 times 0.017 h <b>aviation</b>	(4), (2), (0)
fatalities per hectare	weed control	9.6 E-6	16 times 1.5 h	(4), (2), (0)
<b>total fatalities per ha</b>		<b>35.2 E-6</b>	per 8 rotations	(0), (4)
energy content GJ ha <sup>-1</sup>	at harvesting	171	range 162-180 GJ/ha.y	(5)
total lifespan in years		32	of plantation	(5)
total number harvests		8	rotations	(5)
total fatalities per MJ		6.43 E-12	range: 6.11 - 6.79 E-12	(0), (4)
Deaths		<b>0.06 E-10</b>	per MJ	(0), (4)
Major		<b>8.90 E-10</b>	per MJ	(0), (9)
Minor		<b>1.55 E-09</b>	per MJ	(0), (9)

Sources: (2) Nonhebel 1995: 18; (4) Starr 1976: 19, 25; (5) Meyer *et al.* 1994: 100; (9) DS 1992: 177 and At 1992: 10; (0) and *italics: own calculation*, based on values in Table A.45.

Major: Major accidents.

Minor: Minor accidents.

<sup>19</sup> The data given in ORNL and RFTF (1992) are aggregated in the following table. In their example of a biomass fired power station they give 0.04 farm accidents per year for a wood plantation as a lower value. Using their upper value of 0.17 the fatality rate would be as high as 8.9 E-10 per MJ.

Plant size 30 MW, heat demand 2.9 PJ, capacity factor 70%, annual production 184 GWh,

av. farm accidents 0.04 per year or 2.1 10<sup>-10</sup> per MJ. Source: ORNL and RFTF 1992: 7-21.

To put our value in perspective we mention that in 1991 the Danish agriculture, forestry and hunting sectors caused 11 work related deaths (DS, 1992, 177). Compared to a vegetable production of 33 petajoule, animal production of 103 PJ, wood logs for 40 PJ and wood supply to the furniture and paper industry equivalent to 201 PJ (Sørensen *et al.*, 1994, 47) this would give an average fatality rate of  $0.29 \cdot 10^{-10}$  per MJ, and rates of major and minor accidents of  $8.9 \cdot 10^{-10}$  and  $1.55 \cdot 10^{-9}$ , respectively (At, 1992,10). These values of course do not include fatalities caused by the general aviation activities that we think would be necessary for large willow plantations. However, the smaller time demand for this technology compared to tractors argues for comparable total accident rates.

One factor that we have not addressed yet is the susceptibility of biomass plantations to pests outbreaks. Nonhebel (1992, 24) mentions that willow plantations are made up of clones, this is not so astonishing as they are produced from cuttings, *i.e.* contain a very restricted range of genetic parent material. In principle this can enhance major pest outbreaks when a suitable parasite enters a plantation.

We have partly taken care of this problem with our high rate of pesticide control application, but how sensitive widespread biomass plantations of very restricted genetic material are to such attacks is an open question. Hall (1994, 171) stresses the necessity in species selection and good plantation design as a means to control pests and diseases. If we also assume the implementation of integrated pest management then our accident rates are very likely to be too high. In that case crop protection only should take place about one to two times a year, and not as we have assumed: three times!

#### Greenhouse Gas Emissions

A different question that is not very well disclosed is that of emissions of nitrous oxide by bacterial decomposition of the nitrogen fertiliser applications. Tafdrup (1993) argues for a value of 0.5 per cent of the nitrogen content. Assuming that those and Nonhebel's values are applicable we can estimate the N<sub>2</sub>O emissions from fertiliser application. And from Meyer *et al.* (1994, 103) we have found data on the evaporation of ammonia and NMVOCs, Table A.47:

**Table A.47 Fertiliser application and gaseous emissions of willow plantations**

Topic	Activity	Figure	Remark	Source
<b>Fertiliser application</b>				
N-fertiliser	N-fertilising	2170 kg	per rotation (=490 kg N)	(5)
P-fertiliser	P-fertilising	260 kg	per rotation	(5)
K-fertiliser	K-fertilising	730 kg	per rotation	(5)
lime	liming	1040 kg	per rotation	(7)
<b>Emissions</b>				
N <sub>2</sub> O emissions	from fertiliser	0.5 %		(8)
N <sub>2</sub> O per MJ	do.	0.023 g	range: 0.021-0.024	(8), (0)
NH <sub>3</sub> per MJ	do.	0.101 g	range: 0.096-0.107	(5), (0)
NMVOC per MJ	do.	0.146 g	range: 0.139-0.154	(5), (0)

Sources: (5) Meyer *et al.* 1994: 101, 103; (7) Börjesson 1996: 7; (8) Tafdrup 1993; (0) and *italics: own calculation.*

#### Transportation of Biomass

For the transportation of the biomass to the biogas plants the accident rates mentioned in the ExternE methodology volume (EC 1995/2, 199 f.) have been used. We also follow Meyer *et al.* (1994, 105) in the values used for the average distance (20 km to the plant) and transported volumes (80 bulk metres at  $0.17 \text{ t m}^{-3}$  result in an average load of 250 GJ per lorry and 272 t-km).

**Table A.48 Accident rates of biomass from plantation transport**

Incident type	Figure	Remark
Deaths	9.18 E-12	per MJ
YOLL	3.16 E-11	per MJ
Major	1.19 E-11	per MJ
Minor	37.39 E-11	per MJ

Source: Det Økonomiske Råd (1996), Transportrådet (1993), own calculations

#### *Sugar Beet Data*

While none of the scenarios explicitly includes ethanol production from biomass products rich in sugar or starch, we have chosen to give the value of this crop as an indicator of the externalities from the production of other energy crops, like *e.g.* rape seed or even as an example of the upper range of values from the extraction of biomass residues from agricultural production. So these data do not legitimise a possible argument for *e.g.* substituting methanol with ethanol, especially as the latter processes have not reached the same degree of energetic efficiency, and even worse are uneconomical at the present state.

As we also need data for the treatment of *e.g.* sugar beets for the production of liquid biofuels, we describe the fatality impacts for this kind of production in Table A.49. The energy production per hectare is a value between current and forecasted Swedish production values where we have taken somewhat better climatological conditions in Denmark as a supportive argument.

**Table A.49 Accident data for sugar beet production**

Incident type	Activity	Figure	Remark	Source
fatalities per hectare	planting	<i>0.6 E-6</i>	once 1.5 h	(4), (2), (0)
fatalities per hectare	harvesting	<i>0.6 E-6</i>	once 1.5 h	(4), (2), (0)
fatalities per hectare	N-fertilising	<i>0.3 E-6</i>	3 times 0.25 h	(4), (2), (0)
fatalities per hectare	P-fertilising	<i>0.1 E-6</i>	once 0.25 h	(4), (2), (0)
fatalities per hectare	K-fertilising	<i>0.1 E-6</i>	once 0.25 h	(4), (2), (0)
fatalities per hectare	crop protection	<i>0.6 E-6</i>	three times 0.5 h	(4), (2), (0)
fatalities per hectare	weed control	<i>1.2 E-6</i>	twice 1.5 h	(4), (2), (0)
total fatalities per ha		<i>3.5 E-6</i>		(0)
total lifespan in years		1	of rotation	(0)
energy content GJ ha <sup>-1</sup>	at harvesting	<b>207</b>	range 190-240 GJ/ha	(7)
total number harvests		1		(0)
<b>total fatalities per MJ</b>		<i>1.69 E-11</i>	range: 1.46 - 1.84 E-11	<b>(0), (4)</b>
Deaths		<b><i>0.17 E-10</i></b>	per MJ	(0), (4)
Major		<b><i>8.90E-10</i></b>	per MJ	(0), (9)
Minor		<b><i>1.55E-09</i></b>	per MJ	(0), (9)

Sources: (2) Nonhebel 1995: 18; (4) Starr 1976: 19, 25; (7) Börjesson 1996: 13; (9) DS 1992: 177 and At 1992: 10; (0) and *italics*: own calculations. Major: Major accidents. Minor: Minor accidents.

Also for this feedstock we have data on the fertiliser and liming demand and the resultant emissions of potential greenhouse gases.

Topic	Activity	Figure	Remark	Source
<b>Fertiliser application</b>				
N-fertiliser	N-fertilising	120 kg N		(7)
P-fertiliser	P-fertilising	21 kg P		(7)
K-fertiliser	K-fertilising	42 kg K		(7)
lime	liming	340 kg		(7)
<b>Emissions</b>				
N <sub>2</sub> O per MJ	do.	<i>4.6E-3 g</i>	range: 3.9E-3-5.0E-3	(8), (0)
NH <sub>3</sub> per MJ	do.	<i>0.020 g</i>	range: 0.018-0.022	(5), (0)
NMVOG per MJ	do.	<i>0.121 g</i>	range: 0.104-0.132	(5), (0)

Sources: (5) Meyer *et al.* 1994: 103; (7) Börjesson 1996: 7, 13; (8) Tafdrup 1993; (0) & *italics*: own calculations.

*biorest*

Residues arise from other agricultural and domestic applications like from animal droppings or kitchen waste. Those organic fractions can be collected and the energy content extracted by *e.g.* biogas generation. The potential of biomass residues from agricultural and provisionals production like straw or also household waste has been estimated to have a potential in Denmark of the order of 70 PJ (Nielsen *et al.*, 1994, 37).

If we use biomass residues then the work effort will be low, on the other hand we should count the comparatively small amount of extra work from collecting biomass residues as belonging to the energy sector. For example for straw the composition is as shown in Table A.50.

**Table A.50 Elementary analysis of straw.**

Species	Weight %	Range
carbon	40	35-45
sulphur	0,2	<0,3
hydrogen	5	4,8-5,2
nitrogen	0,04	<0,5
oxygen	35	33-38
chlorine	0,4	0,1-0,8
water	12	0-25
ash	4	3-8
LHV	15	14-16 GJ/t

Source: Formidlingsrådet 1989, 28.

*Energy Input-Output Relations*

Several studies have investigated the input output relationships of biomass sources. One of the most detailed is Börjesson (1996a) that we shall shortly present to describe the output input ratios for a few residues.

**Table A.51 Energy data for various biomass residues.**

Biomass resource	logging res. final today	logging res. final 2015	logging res. 1st today	logging res. 1st 2015	straw today	straw 2015
Motor fuels	0.15	0.21	0.37	0.31	0.66	0.80
Seeds						
Fertilisers, etc						
Biocides						
Machinery	0.01	0.01	0.01	0.01	0.52	0.39
Mach. transp.	0.01	0.01	0.01	0.01		
Biom. transp.	0.03	0.06	0.07	0.12	0.29	0.37
<b>Total</b>	<b>0.20</b>	<b>0.28</b>	<b>0.46</b>	<b>0.60</b>	<b>1.47</b>	<b>1.56</b>
<b>Energy yield</b>	<b>5.4</b>	<b>7.9</b>	<b>10</b>	<b>13</b>	<b>36</b>	<b>36</b>
<b>Net Yield</b>	<b>5.2</b>	<b>7.62</b>	<b>9.54</b>	<b>12.4</b>	<b>34.5</b>	<b>34.4</b>
<b>O/I ratio</b>	<b>28</b>	<b>28</b>	<b>22</b>	<b>22</b>	<b>25</b>	<b>22</b>
<b>Chosen</b>	biogas	biogas	biogas	biogas	liquid	liquid

Source: Börjesson 1996a, 13.

All data, except O/I, given in GJ per hectare and year.

**2015:** this data are given for methanol fuelled machines.

**logging res. final:** logging residues after final felling.

**logging res. 1st:** logging residues after first thinning.

**straw:** it is assumed that straw as a residue will not change in abundance in the future.

**biom. transp.:** transport 50 kilometres by truck.

### Occupational and Transport Impacts

With regard to the occupational impacts from the residues of production we refer to the estimates for transport risks for *bioplant*, biomass from plantations. The same accident rates should be applicable for this kind of transport, too; unless of course it can be shown that this transport will be going on by tractors. In that case the accident rates will be higher, as tractors are normally implicated in more serious accidents than lorries.

### Environmental Impacts

There could be a range of environmental impacts from biomass residues. For straw the content of heavy metals plays a significant role. It is known that problems arise with cadmium in the fly ash where limit values are exceeded, and that this kind of ash cannot be recirculated to the fields any more. This is not so pronounced for bottom ash, where limit values *pt.* are not exceeded but might so in the future, if regulations become stricter.

With regard the possible effects of manure storage, impacts on groundwater, smell from accidentally released volumes, or simple mechanical accidents are perceivable. In this case the containers would release a large amount of manure into the environment potentially with fatalities as a potential result but very surely with environmental pollution.

### biogas

Biogas can be produced out of biomass or waste. A typical example of the current technology stage is the biogas plant in Ribe (DK-DEA 1996a, 12 ff.) which converts about 110 thousand tons of animal waste and 30 thousand tons organic waste into biogas equivalent to 100 terrajoule yearly. This is equivalent to an energy conversion efficiency of only 19 per cent with regards the energy contained in the original manure and waste according to the value given in Table A.52. In the future this efficiency should rise and reach 50 per cent within the next decades.

**Table A.52 Elementary analysis and energy content of waste**

Species	Weight %	Range
carbon	25	15-35
oxygen	18	12-24
hydrogen	3	2-5
nitrogen	0.6	0.2-1.0
sulphur	0.003	0.002-0.6
chlorine	0.7	0.5-1.0
water	20	15-35
ash	25	15-40
LHV (GJ/t), Municipal solid waste	8.8	8.4-9.2 GJ/t
LHV (GJ/t), industrial waste	13.7	8.7-19.0 GJ/t

(Source: Formidlingsrådet 1989, 59). LHV: lower heating value. HHV: higher heating value.

Biogas contains is mostly consisting of methane ( $\text{CH}_4$ ). This gas has a high GWP so that leakages during production and transport, *e.g.* via pipelines or in bottled form, have to be avoided to keep low contributions to the GWP of any future energy system. Otherwise biogas production, as well as hydro power electricity, actually has a large *onus*.

As a typical biogas production site we have chosen the Ribe Biogas Plant that is extensively described in Nielsen and Holm-Nielsen (1996), Table A.53. Such biogas plants are fed with slurry<sup>20</sup> from husbandry which is transported in tankers on the roads to the plant. To a minor degree some industrial organic waste is exploited.

<sup>20</sup> Only a minor part is currently being transported in the solid form (DK-DEA 1995, 19).



Table A.53 Ribe Biogas Plant technical data

parameter	value	source	remarks
<b>Technical data</b>			
spec. invest.	2200 ε/kW	DK-DEA 1995b, 13	45.3 M-DKR <sub>1990</sub>
O&M	9.6 % pa	DK-DEA 1995b, 14	4.6 M-DKR <sub>1993</sub>
capacity	2.7 MW	Nielsen&Holm-Nielsen 1996	from 10000 m <sup>3</sup> per day
annual load	8700 h	Nielsen&Holm-Nielsen 1996	
lifetime	20 y	Nielsen&Holm-Nielsen 1996	
lifetime generation	469.8 GWh		
overall efficiency	20.7 %	Sørensen <i>et al.</i> 1994, 47	today
overall efficiency	50.0 %	Sørensen <i>et al.</i> 1994, 49	future
capacity, net	10000 m <sup>3</sup> d <sup>-1</sup>	Nielsen&Holm-Nielsen 1996	11500 m <sup>3</sup> gross
<b>Input and composition</b>			
biomass	410 t d <sup>-1</sup>	Nielsen&Holm-Nielsen 1996	of which:
pig slurry	20 %	Nielsen&Holm-Nielsen 1996	
cattle farm slurry	60 %	Nielsen&Holm-Nielsen 1996	
industrial organic waste	20 %	Nielsen&Holm-Nielsen 1996	
<b>Biomass transport</b>			
average total	32 km	Nielsen&Holm-Nielsen 1996	
average animal slurry	22 km	Nielsen&Holm-Nielsen 1996	
<b>Biogas composition</b>			
CH <sub>4</sub>	64.8 %	Nielsen&Holm-Nielsen 1996	
CO <sub>2</sub>	35 %	Nielsen&Holm-Nielsen 1996	
rest (H <sub>2</sub> , N <sub>2</sub> , H <sub>2</sub> S) as H <sub>2</sub> S	0.2 %	GENERIC.PRC	biogas
combustion value (MJm <sup>-3</sup> )	23.4	Nielsen&Holm-Nielsen 1996	
<b>Material demand</b>			Fabric\biogas-centr
Steel	5 t	GENERIC.PRC	@ 22.2 GJ/t
Concrete (Cement)	10 t	GENERIC.PRC	@ 4.6 GJ/t
<b>Material transport per unit</b>			
steel-truck	150 km	EC 1995/3, 90	
steel-railway	50 km	EC 1995/3, 90	
concrete-truck	50 km	EC 1995/3, 90	
<b>Process demands per MJ<sub>bg</sub></b>			
process heat	0.12	Nielsen&Holm-Nielsen 1996	
electricity	0.01	GENERIC.PRC	
<b>Emissions per MJ<sub>bg</sub></b>			
CH <sub>4</sub>	0.47 g		
<b>Miscellaneous</b>			
Area demand	1 ha		

The hydrogen sulphide (H<sub>2</sub>S) content is taken directly from the GEMIS computer data base. In any perceivable future scenario this value is probably too high, as natural gas, to prevent corrosion problems is cleaned to contain only 5E-4 to 2E-2 weight per cent sulphur (Baumbach, 1994, 27-28). Further treatment of the biogas also with respect to other compounds might be a solution and has been proposed (Energistyrelsen, 1992, 20), or is already being tested, like in the Fangel Biogas Plant (DK-DEA 1995b, 12), albeit only to fulfil values of about 700 to 1500 ppm H<sub>2</sub>S.

Biogas has to fulfil demands of 700 to 1500 ppm H<sub>2</sub>S or less to ensure proper motor performance when the biogas is used in CHP installations today. This has formerly been achieved without special purification (DK-DEA 1995b, 11). This is equivalent to 0.09 to 0.2 weight per cent! Another literature value gives 0.1 to 1.5 weight per cent (Børgesen *et al.*, 1992, ordliste). Unless further more stringent demands are put on the H<sub>2</sub>S content of biogas, there will be a major contribution to SO<sub>2</sub> emissions of the future energy systems, where biogas will be a major energy source.

As we have noted the high emissions of untreated biogas, we assume that for using it on a larger scale the biogas will be cleaned for H<sub>2</sub>S in the future, so that its H<sub>2</sub>S content will only be 0.005 weight per cent. This especially applies for the transport sector. In any large scale applications there will be used end-of-pipe technologies to reduce the SO<sub>2</sub> emissions, as is the case today with oil or coal fired installations.

### *Emissions to the Air*

Biogas production from slurry and waste is not without emissions. The greenhouse gas methane can be liberated from the slurry tanks before and during slurry collection and transport to the biogas plant. While collecting the slurry and using it in a biogas plant will reduce methane emissions vastly compared to unmitigated slurry tank emissions, Nielsen and Holm-Nielsen (1996) calculate the reduction for the Ribe biogas plant to be 160 t CH<sub>4</sub> per year, the extension of the energy system necessitates the inclusion of those emissions.

Still there will be some methane emissions at the source of the slurry supply from anaerobic digestion processes in very much cattle. From data on the emissions of methane from husbandry (Fenhann, 1996) we have gained knowledge that the annual methane emissions in Denmark in the year 1990 were about 160 billion grams stemming from 11.7 million animals (cattle and mainly pigs). This amount is the contribution from enteric fermentation. An equivalent amount, 125 billion grams, stems from animal dejections (Fenhann and Kilde, 1994, 52).

Part of these emissions will have to be included in the energy sector's greenhouse balance. Here we shall try to estimate how large the sums can be. We assume that we can neglect the contributions from the enteric fermentation, as it also in the future will be considered to belong to the agricultural sector, so that the only possible contribution stems from the animal dejections, that is from the slurry. This slurry is stored some days before it is transported to the biogas plant. In summer there will be no such transport and no biogas production, as the animals will be grassing outside and so their droppings can not be recovered.

In the winter current legislation requires the farmers to have storage capacity for several months. It is prohibited to spread slurry during the wintertime, when the low temperatures will not allow the plants from taking up the nitrate from the manure, to prevent the nitrate from being precipitated into the rivers and the groundwater.

If we assume that slurry on average is stored about three months over the winter time, and that a biogas plant will enable the transport after only an average period of a week storage at the farm, then we can estimate the amount that in the future should be included as belonging to the energy sector.

We also assume an average fodder consumption of 3 kilogram per animal (a private conversation from Niels Kilde gives a production of volatile solids of 5.1 kg per day for dairy cattle, 2.7 for non-dairy cattle and 0.5 kg for pigs), and that the slurry is diluted by water so that it weighs double the amount of the dejections. Thus, the average emissions are 0.5 g CH<sub>4</sub> per kilogram slurry over the nine days it will be stored at the farm.

Also from Kilde (1997) we have gained knowledge of the distribution of the emissions when the slurry is stored in manure tanks over the winter period. Only about 10 per cent of the emissions are actually taking place during this storage, the major share is being liberated, when the slurry is being applied on the fields in spring. Therefore the emissions that may be taken into account from the slurry production as a precursor to the biogas production are only about 0.05 grams per kilogram of slurry.

Another source is degassing of the digested slurry after the process in effluent stores before application on the fields. Nielsen and Holm-Nielsen (1996) give a value of 2-3 %, this means an

emission of around 40 t CH<sub>4</sub> per year which, compared to the biogas generation of about 85 TJ per year, gives a methane emission of 0.47 gram per MJ.

An unsolved problem so far with biogas production is the desirability of access to industrial waste with a high content of organic matter as a feedstock. This “catalyst” enhances biogas production significantly, but it is feared that the supply could become less in the future, and household waste is no alternative to industrial waste, as shown by the example of the Elsinore biogas plant. The challenge is to ensure economic viability of biogas plants, which is generally not yet the case in Denmark today (DK-DEA, 1995b, 27).

Figure A.2 Flow diagram of Ribe Biomass Plant

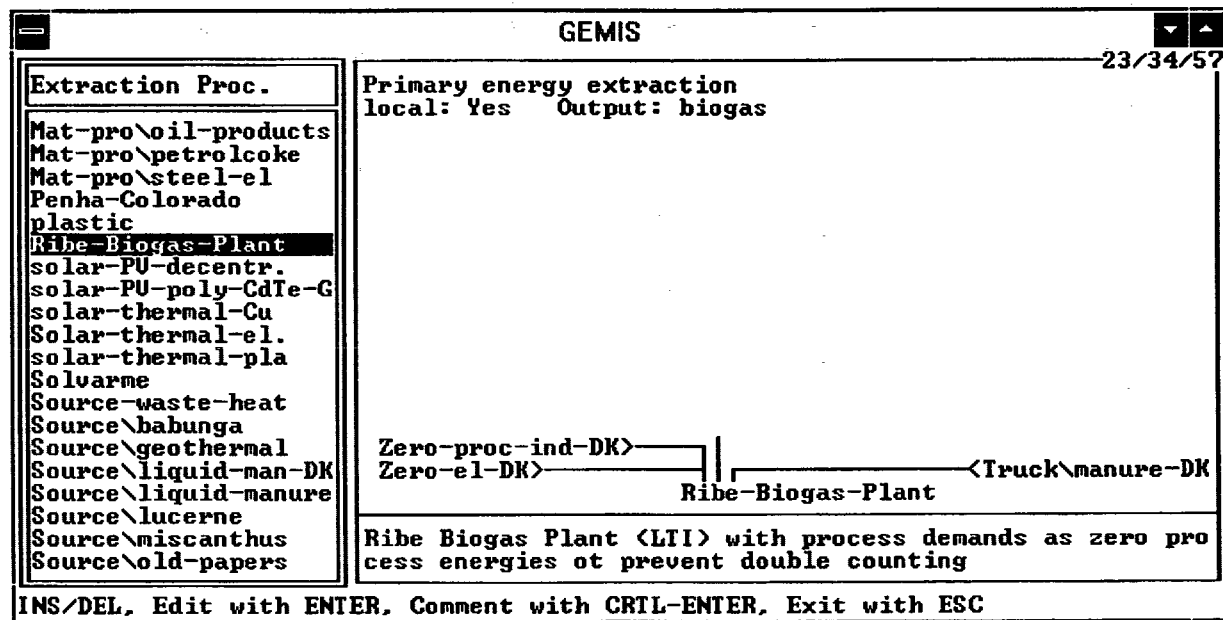

*hydrogen*

In the fair market scenario hydrogen is used in fuelling combined cycle power stations for domestic applications, but even more so as an export resource. Hydrogen is assumed to be produced by gasification of biomass from plantations in centralised installations, Table A.54, and by electrolysis in reversible fuel cells, see under SOFC. A flow diagram for the upstream processes can be found in Figure A.3.

Table A.54 Data for biomass to hydrogen conversion

parameter	value	source	remarks
<b>Technical data</b>		see Table A.53	
capacity	2 MW	estimated	
overall efficiency	50.0 %	Nielsen&Sorensen 1996, 109	net
<b>Input and composition</b>		see Table A.53	
woody biomass	20 t d <sup>-1</sup>	estimate	
<b>Biomass transport</b>		see Table A.53	
<b>Material demand</b>			Fabric\biogas-centr
Steel	5 t	GENERIC.PRC	@ 22.2 GJ/t
Concrete (Cement)	10 t	GENERIC.PRC	@ 4.6 GJ/t
<b>Material transport</b>	per unit	see Table A.53	
<b>Miscellaneous</b>			
Area demand	10 ha		

*Occupational and Environmental Impacts from Hydrogen Technology*

We cannot describe the public and occupational health impacts of a widespread use of hydrogen technology, as we have not found data on this subject. There are different estimates on the risk of hydrogen technology compared to commonly used fossil based technologies, and hydrogen may have both advantages and disfavours compared to those.

**Figure A.3 Hydrogen production from biomass input**

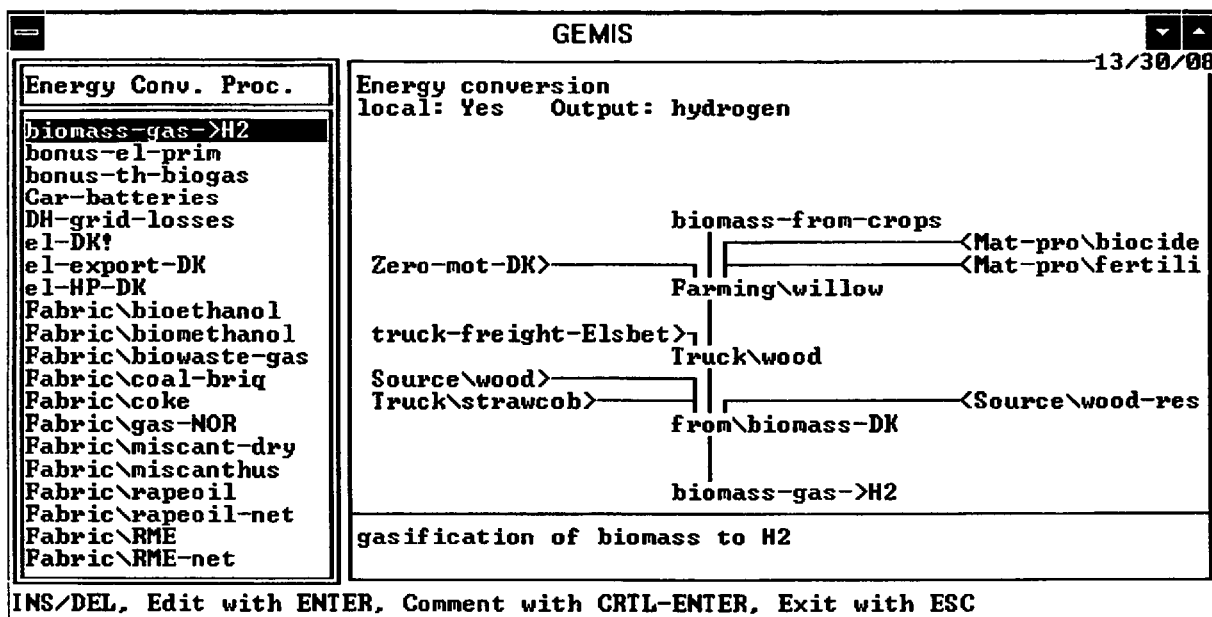

*liquid*

In our future scenarios liquid biofuels are used in the transport sector. We will assume that the technology is comparable to the one of biogas production, see Table A.53 for details not found in the following Table A.55.

**Table A.55 Liquid biofuels from biomass data**

parameter	value	source	remarks
<b>Technical data</b>		see Table A.53	
capacity	2 MW	estimated	
overall efficiency	44.0 %	Nielsen&Sørensen 1996, 109	net
overall efficiency	47.8 %	Sørensen <i>et al.</i> 1994, 51	net
<b>Input and composition</b>		see Table A.53	
biomass	20 t d <sup>-1</sup>	estimate	woodchips
<b>Biomass transport</b>		see Table A.53	
<b>Material demand</b>		Fabric\biogas-centr	
Steel	5 t	GENERIC.PRC	@ 22.2 GJ/t
Concrete (Cement)	10 t	GENERIC.PRC	@ 4.6 GJ/t
<b>Material transport</b>		per unit	see Table A.53
<b>Miscellaneous</b>			
Area demand	1 ha		

Our assumption might not be the best one, but there are no other data in the literature that we had at hand, and GEMIS (1992) does not give data for this technology either. There are differences between biogas and methanol production. Process heat at a high temperature needs to be supplied to feed the conversion process from biomass that is being gasified to enable the reactions with water that lead to the formation of methanol. This needs a lot of energy that we

have assumed is provided for by the burning of some of the input material, the wood chips from willow plantations. The high process heat demand makes that the overall efficiency of the process is not very high, it is with values of around 46 percent actually lower than is the case for today's traditional refineries.

As indicated before we have presented sugar beet production for ethanol production as an alternative to methanol production from woody biomass. Methanol production is energy efficient today, while ethanol has not yet been produced at an energetical gain. Therefore methanol has been assumed in the two future scenarios to be a fuel used in the transport sector. Beside the data on the material demand for a methanol plant, unfortunately we cannot give other figures on the work environment or public health impacts from the production.

For the transport of liquid biofuels the same accident rates apply as for the transport of woody biomass.

## Fossil Fuels

Fossil fuels have been used massively since the early days of the industrialisation. Their advantage is commonly taken to be their storability and their high energy density, which however is an artefact of their geological life history. Counting the genesis of the carbon rich fossil fuels which is in the region of several decadal millions of years even a piece of high grade anthracite is only carrying a ridiculously small amount of the original solar radiation that was used to convert water and atmospheric carbon dioxide into carbohydrates by the plants of the Jurassic and Triassic periods. This material was later converted to carbon rich matter by emitting volatile matter, mainly methane and water, during the carbonisation process (Patterson, 1987).

The energy density of today's solar collectors and PV panels by measuring the harvest of solar energy is comparatively several orders of magnitude bigger, but the cliché of the high energy density of fossils is perpetuated in the public discussion. This seems to be a result of an engineering point of view, whereby the current energy demand of society shall be fulfilled by a rational exploitation of raw materials. In that sense coal, oil, or natural gas, measured in mass or volume, their availability, or handibility prove advantageous to renewable energy forms.

### *Sustainability of Fossils ?*

The very physical limitation of the reserves of fossils impinges upon a ecologically sustainable development that is obeying the *hard* rule of sustainability: that the natural stock at any time is not delimited by any human generation and is perpetuated to the following ones in its true extent (definition given in lecture material by O. Hohmeyer, 1995).

To exemplify the hard definition each generation should leave the World in exactly the same state as it itself experienced when it came into being, so the exact number of trees, roads, houses, even humans. This definition does not seem to be workable in a dynamic society as ours. the problem is also related to technological changes and changes in the perception of resources. For example oak trees were planted several hundred years ago to insure that the size of the Danish fleet could be maintained. Today, when the trees are full grown we, however do not need oak wood anymore to build ships.

One can argue that the development of mankind has made necessary the exploitation of fossil fuels, knowing that their reserves are limited, and that we eventually have to establish other energy systems better suited to the definition of *hard* sustainability. The relative ease with which we can fulfil our energy needs today means we can build up a stock of assets to help us in this conversion process. Therefore the exploitation of the fossils does not constitute a harm for mankind, as the

necessity to change the energy system to make it more ecologically sustainable has been accepted. This is the definition of *soft* sustainability.

### *Greenhouse and Fossils*

The question of which path to choose for softening the global reliance on fossils has importance in the greenhouse debate, too. While the International Panel on Climate Change (IPCC) has been stressing the need to initiate rapid emission reductions (IPCC, 1995), newer research based on a combination of ecological and economical ideas (Wigley *et al.*, 1996) seems to indicate the possibility of following the *Business As Usual* (BAU) path for still some ten or twenty years before global reductions of amongst others CO<sub>2</sub> emissions have to be realised.

It has to be stressed, though, that the scenarios given in Wigley *et al.* (1996) imply somewhat lower emissions later during the 21st century in order to effectuate stabilisation of atmospheric CO<sub>2</sub> levels than the original IPCC work (based on Enting *et al.*, 1994). Actually Wigley *et al.* (1996) demand CO<sub>2</sub> emissions to drop somewhat below zero for a stabilisation goal of 350 ppm. This can be rendered unrealistic considering today's situation of the global food markets and a rising population pressure that would ensure a continuing contribution from land use changes rather than a sink from reforestation.

Two things have to be taken into consideration: rising global welfare might make a transition to other energy systems more easy, but it also leads to a larger amount of services that have to be fulfilled energywise, which in principle makes such a transition more difficult. Even though the industrialised countries have been experiencing a trend towards a dematerialised economy during the last decades as expressed in the structural changes of their economies, the fact remains that the tertiary and quaternary sectors, administering and developing it, depend heavily on the total material throughput of the economy in the industrial sector (Jespersen, 1995).

### *Fossil Dependence*

Today we are experiencing a situation where globally fossil fuels stand for the majority of the primary energy supply. For Denmark they lead to domestic CO<sub>2</sub> emissions of about 60 million tons annually. This value has been essentially constant since the 1970s. Fossils are partly imported by Denmark, partly produced domestically.

Electricity generation is nearly exclusively responsible for the imported solid fuels, mainly steam coal, whereas the transport sector relies on liquid fuels, where the Danish production is more or less making the country self sufficient. On the other hand petroleum and oil products based on the domestic oil production in the North Sea are exported, while on the other hand other products are imported to cover the demand not serviced by the Danish refineries.

The self sufficiency factor regarding oil is about 100 per cent (DONG, 1994) and will remain so for the next three till four decades when domestic energy sufficiency will stop, and Denmark will have to import fuels again (Auken, 1996), unless the development towards a different energy system obviates this dependency on fossil fuels. The self sufficiency factor regarding natural gas is currently clearly above 100 per cent, so that a large part of the production is sold to Germany and Sweden.

### *Environmental Effects of Fossil Fuels*

Fossil fuels have certain environmental consequences that are important to take into account when arguments towards abolishing them are made. They are not renewable, i.e. they will not last forever, and so they are not ecologically sustainable. They cause environmental impacts at the site of their production and conversion, the transport to the consumers, and the impacts from the residues of the direct use. In a LCA we have to make sure that we take into consideration all the

important aspects, but due to economical reasons we have to constrict every analysis to a practical basis.

Defining the area of a LCA, the system's boundaries, is not an easy process (Vigon *et al.*, 1993). One will have to rely on a fair share of intuition during the process of deciding which factors to include in the investigation, and which to let out. This can be a problem, as seemingly unimportant impacts, or doses, can lead to larger responses than one is originally aware of when society's perceptions of the effects of certain activities change (Vigon *et al.*, 1993) or follow-on impacts have been overlooked (Sørensen 1993a, 31). There is, unfortunately, no way to circumvent this caveat, as human experience naturally is limited.

In this report we have tried to take as many factors into consideration as could be included, but this does not exclude the possibility that we might have neglected impacts that later will show to have major consequences. Experience also tells us that the human knowledge base expands at a rapid pace, so that impacts not rendered important today, could very well be assessed much more critically in the future (Sørensen, 1996x).

When we now present the fossil fuels we stress that we do this critically on the background of the current knowledge, and that our analysis might not contain factors that become more important in the future, both in the near and the longer term, than they are today.

### **Overview of Fossil Fuels**

When we present this overview it is to tell what impacts we have included in our investigation of the life cycle costs of the present energy system. We also note that the oil and petroleum products cycle plays a role in the fair market scenario that employs fossil fuels for the transport sector.

#### *Coal*

Coal is almost exclusively used in the Danish energy system as a fuel in power stations that generate about 97 per cent of the total indigenously generated electricity. Denmark imports coal, the country neither has reserves nor production sites of this solid fuel. The proximity of the power stations at coastal situations makes transport and handling easy.

Coal is being mined in both surface and shaft mines. The latter do not necessarily invoke as many visible impacts on the environment as surface mines do, but the impacts on the environment may as well be grand. Surface mines suffer from a bad image in the public (Libicki, 1994) as the impacts on the environment are easily perceived. They also tend to produce quite distinct changes in the landscape, involving large movements of earth, and their extension in the heavily populated areas of the industrialised countries has given rise to public concern.

Various potential externalities have been mentioned in the latest studies on the coal cycle externalities (EC, 1994/2). They arise from both direct impacts on the workers, ranging from health impairment to lethal accidents, from the very operation of the mines, to indirect effects on the public from the operation of the mines itself, like visual impacts from open surface mines, to indirect effects on the environment from the enhanced greenhouse effect (Hohmeyer and Ottinger, 1994; Sørensen, 1996; Cline, 1992; Fankhauser, 1995; Nordhaus, 1994) and emissions of oxidising substances that lead to acidification impacting human made structures and the natural environment (EC, 1995/3).

#### *Occupational Impacts*

Opencast mines or shaft mines bring about very different possible externalities in the form of work related impacts. Workers in shaft mines might suffer from the structural instabilities of the geology and can be buried in rock bursts.

Regarding the fatality rates in mines there are only sparse data available for countries or mines except from the ones analysed in the ExternE project. Some figures have been found for fatality rates in the former Soviet Union, especially for the Donets Basin in Ukraine, (Levine, 1988, 25), Table A.56.

**Table A.56 Occupational impacts of coal mining activities**

Accident type & country	Figure	Remark	Source
Deaths, USSR	0.777	per 1 Mt coal produced	(a)
Deaths, Donets	1.042	per 1 Mt coal produced	(a)
Deaths, USA surface	0.028	per 1 Mt coal produced	(c)
Deaths, UK	0.20	per 1 Mt coal produced	(b)
Deaths, Germany	0.55	per 1 Mt coal produced	(b)
YOLL, UK	-	per 1 Mt coal produced	
YOLL, Germany	20.6	per 1 Mt coal produced	(b)
YOLL, lignite	0.24	per 1 Mt coal produced	(b)
Major, UK	8.14	per 1 Mt coal produced	(b)
Major, Germany	16.3	per 1 Mt coal produced	(b)
Major, lignite	0.20	per 1 Mt coal produced	(b)
Minor, UK	69.96	per 1 Mt coal produced	(b)
Minor, Germany	164	per 1 Mt coal produced	(b)
Minor, lignite	3.4	per 1 Mt coal produced	(b)

Sources: (a) Levine, 1988, 25; (b) EC, 1995/3: 144, 151; (c) ORNL and RFTF 1992, p. 5-6.

YOLL: Years of life lost. Major: Major accidents. Minor: Minor accidents.

We have used the figures for the whole of the former USSR also for developing countries from which the Danish utilities import coal, like China, Vietnam or Latin American countries and the former COMECON regions. With regards Danish imports from other European countries we apply the German values, for imports from the UK and South Africa this value, also from EC (1995/3, 144 and 151). For imports from Australia, the USA and Canada we use the fatality values for surface mine from the study of the Oak Ridge National Laboratory (ORNL and RFTF, 1992, p. 5-6). For such surface mines we used the values of the German lignite mines for YOLL, and major and minor accidents. All are given in Table A.56.

### *Transport Impacts*

Data from the accident impacts from other activities related to the coal cycle like handling and transport have been taken from the ExternE study (EC 1995/3, 153), and we have not differentiated between different countries for those impacts. However, we have aggregated the data to describe the common impact due to the combined transport mode used for importing coal to Denmark.

**Table A.57 Transport impacts of coal**

Incident type	Figure	Remark
Deaths, railway	0.027	per 1 Mt coal transported
Deaths, barge	0.108	per 1 Mt coal transported
YOLL, railway	0.88	per 1 Mt coal transported
YOLL, barge	3.6	per 1 Mt coal transported
Major, railway	0.31	per 1 Mt coal transported
Major, barge	0.61	per 1 Mt coal transported
Minor, railway	16.9	per 1 Mt coal transported
Minor, barge	15.9	per 1 Mt coal transported

Source: EC, 1995/3, 153.

YOLL: Years of life lost. Major: Major accidents. Minor: Minor accidents.

The way the different transport modes are integrated in the TEMIS runs is shown in Figure A.4. The transport structure is similar for the other fossil fuels, where the current import is taking



place from several countries and with different transport modes. This has been described by Kuemmel (1996).

Figure A.4 Average transport modes for Danish coal import

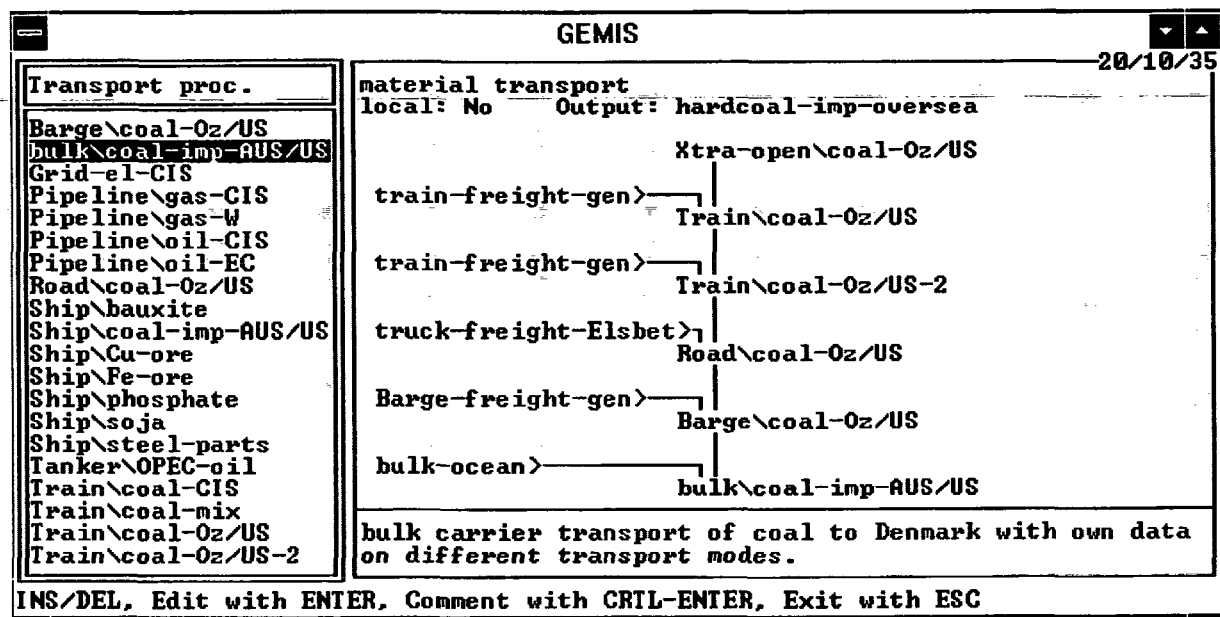

*Environmental Impacts*

In the following a range of the environmental impacts have been shown in analyses of lignite mining operations. We acknowledge that lignite is not typically used in Denmark. Nevertheless we use the values gained from those investigations, as a large share of the Danish coal import originates from surface mines with similar problems!

Generally, surface mining operations have more widespread consequences on the surroundings than shaft mines. Big problems with both mine types is the amount of inert material, slag heaps, produced together with the coal and that not in all cases is fed back extraction sites. A value of 0.5 m<sup>3</sup> of overburden per GJ of lignite, or about 1 ton per GJ, seems to be typical (EC, 1995/3, 383; Metz *et al.*, 1990, 86). For hard coal we assume a value of 300 kg per GJ for surface mines and a smaller value for shaft mines, about 10 kg per GJ.

The excavation of such material can lead to acidification of the ground water, when Pyrite, FES<sub>2</sub> is oxidised as described in the ExternE report on the lignite fuel cycle (EC, 1995/3, 515ff.). This process can go on for several years after re-establishing the landscape. As a first measure to minimise this effect one can reduce the time during which the overburden is air-exposed. Secondly one can apply lime.

At a value of 1 kg lime per MWh of electricity produced with the lignite reference plant when the exposure time of the pyrite bearing waste heap is limited to below half a year (EC, 1995/3, 534) this results in a value of 100 g lime per GJ of lignite and so of c. 30 g lime per GJ of hard coal for surface mines.

Also lowering the ground water table before and during the mining operations severely impacts the local water balance and influences an area several kilometres away from the mining site. The total pumping rate to keep the mining area dry depends on the hydraulic transmissivity of the aquifers, the perimeter of the mining area, the required lowering of the water table and the mining centre and the mean recharge rate of the rain fall within the affected area (EC, 1995c, 507).

We have found some values for the ground water pumping necessary in lignite mining in Metz *et al.* (1990, 86 f.). For the East German Lausitz mining district a value of 1736 million m<sup>3</sup> are given compared to a production of 310 million tons lignite. This gives a value of about 0.6 m<sup>3</sup> water per GJ. The current Danish energy system, however, uses hard coal and we have to correct for the larger energy density of this fuel. We therefore conclude that the Danish import of coal is equivalent to a ground water load of 0.2 m<sup>3</sup> per GJ. This value is not very secure.

Dust emissions from surface mines are another problem. EC (1995c, 392) mentions a value of 0.2 kg of dust per ton lignite handled, equivalent to 24 grams per GJ. For our purposes we assume a value of 8 gram dust per GJ hard coal from surface mines.

**Table A.58 Environmental Impacts of Coal Production**

Emissions or Demands	Rate	Remark
Lime overburden, surface	30	g per GJ coal produced
Dust, surface	8	g per GJ coal produced
Overburden, surface	300	kg per GJ coal produced
Groundwater, surface	200	kg per GJ coal produced
Slag heap, shaft	10	kg per GJ coal produced
Groundwater, shaft	10	kg per GJ coal produced

Sources: EC 1995/3, Metz *et al.* 1990.

Another effect related to the production of coal is the liberation of the greenhouse gas methane. This is especially a problem for underground mined coal. The amount of methane liberated from the produced coal depends on the depth of the mines, the deeper the higher the emissions. In places this methane is already utilised as a fuel for gas fired engines but generally we have to take into consideration these emissions. We have calculated with an average of 4.9 kg methane liberated per ton of coal produced<sup>21</sup>. This is an average value from IEA (1994) and we have not differentiated between the different regions that Denmark is importing coal from. IEA does point out, however, that their value probably overestimates the total amount as there is a difference in the share between the actual world production from surface and pit mines, compared to the data that they applied.

#### *Crude Oil*

With regard the externalities of oil production and transport we have only found data for Norwegian and British production from EC (1995d).

#### *Occupational Impacts*

The accident rates for oil extraction are given in EC (1995d, 126).

**Table A.59 Occupational impacts of crude oil extraction**

Incident type	Figure	Remark
Deaths, UK	0.037	per 1 Mt crude oil produced
Deaths, Norway	0.0036	per 1 Mt crude oil produced
YOLL, UK	-	per 1 Mt crude oil produced
YOLL, Norway	-	per 1 Mt crude oil produced
Major, UK	0.044	per 1 Mt crude oil produced
Major, Norway	0.69	per 1 Mt crude oil produced
Minor, UK	0.39	per 1 Mt crude oil produced
Minor, Norway	6.2	per 1 Mt crude oil produced

Sources: EC, 1995/4, 126.

YOLL: Years of life lost. Major: Major accidents. Minor: Minor accidents.

<sup>21</sup> *i.e.* about 662 grams methane per MWh of coal produced.

We have used the data for UK for all countries except for Norway.

### *Transport Impacts*

For the transport of crude oil we used the data given in EC (1995d, 128).

**Table A.60 Impacts of crude oil transport**

Incident type	Figure	Remark
Deaths	0.16	per 1 Mt crude oil
YOLL	5.4	per 1 Mt crude oil
Major	0.94	per 1 Mt crude oil
Minor	12.4	per 1 Mt crude oil

Sources: EC, 1995/4, 128.

YOLL: Years of life lost. Major: Major accidents. Minor: Minor accidents.

These values might, all in all, be a overestimate as only part of the crude oil imported to Denmark originates outside the North Sea area.

### *Environmental Impacts*

There are several environmental impacts from crude oil transport. Both during operational activities and during accidents, oil spills may occur, and the latter can have drastic consequences. No quantification is tried to described this matter, we acknowledge that there is ongoing work within the ExternE project, and new data can be expected in the near future.

### **Petroleum Products**

#### *Occupational Impacts*

In order to describe the health impacts from petroleum products we have chosen the data in EC (1995/4, 130) on the occupational health impacts from refineries.

**Table A.61 Refinery occupational health impacts**

Incident type	Figure	Remark
Deaths	0.01	per 1 Mt crude oil
YOLL	0.34	per 1 Mt crude oil
Major	0.28	per 1 Mt crude oil
Minor	10.1	per 1 Mt crude oil

### *Transport Impacts*

We used the data given for fuel oil transportation by barge for transport health impacts of petroleum products, as we presumed that they are transported in smaller scale vessels than crude oil.

**Table A.62 Impacts of fuel oil transportation by barge**

Incident type	Figure	Remark
Deaths	0.10	per 1 Mt crude oil
YOLL	3.5	per 1 Mt crude oil
Major	0.56	per 1 Mt crude oil
Minor	15.5	per 1 Mt crude oil

Sources: EC, 1995/4, 130.

YOLL: Years of life lost. Major: Major accidents. Minor: Minor accidents.

*Environmental Impacts*

Refineries cause several environmental impacts. In the CORINE data base they are classified as large point sources, and they will emit SO<sub>2</sub> and NO<sub>x</sub> from their own use of petroleum products during the refining process.

**Table A.63 Refinery data sheet**

parameter	value	source	remarks
<b>Technical data</b>		<b>per unit</b>	Refine\gasoline
capacity	1000 MW	GENERIC.PRC	
annual load	7000 h	GENERIC.PRC	
lifetime	20 y	GENERIC.PRC	
efficiency	99.5 %	GENERIC.PRC	
lifetime generation	140 TWh		
<b>Material demand</b>		<b>per unit</b>	spec. energy demand
Steel	35000 t	GENERIC.PRC	
Concrete (Cement)	10000 t	GENERIC.PRC	
<b>Material transport</b>		<b>per unit</b>	
steel-truck	200 km	GENERIC.PRC	
concrete-truck	50 km	GENERIC.PRC	
<b>Emissions</b>		<b>per MWh<sub>out</sub></b>	
SO <sub>2</sub>	195 g	GENERIC.PRC	calculated
NO <sub>x</sub>	47 g	GENERIC.PRC	calculated
particulates	6 g	GENERIC.PRC	calculated
CH <sub>4</sub>	3.6 g	GENERIC.PRC	
NM VOC	515 g	GENERIC.PRC	
<b>Process demand</b>		<b>per MWh<sub>out</sub></b>	
electricity	0.01	GENERIC.PRC	
process heat	0.11	GENERIC.PRC	
<b>Miscellaneous</b>			
Area demand	15 ha		
Output	gasoline	GENERIC.PRC	

calculated: data calculated using the TEMIS program.

**Natural Gas**

Denmark is becoming self sufficient with respect to natural gas, and so imports do not play a role at all. The environmental and occupational effects of natural gas production are described in EC (1995/4) and GEMIS (1992).

*Occupational Impacts***Table A.64 Occupational health impacts from natural gas production**

Incident type	Figure	Remark
Deaths	3.27E-9	per MJ
YOLL		per MJ
Major	2E-8	per MJ
Minor	1.18E-7	per MJ

Sources: EC, 1995/4, 322, own calculations using an energy content of 39.3 GJ m<sup>-3</sup>.

YOLL: Years of life lost. Major: Major accidents. Minor: Minor accidents.

*Environmental Impacts*

Impacts on the environment of natural gas production are similar to the ones for crude oil production. Water based drilling fluids are used that may be liberated, and cuttings from the well drilling are dispersed around the platforms; but all in all such emissions are characterised to be insignificant, and there are regulations forcing the producers to reduce the amount of oil in the

discharged cutting muds (EC, 1995/4, 266 ff.). We have not assessed those any further or tried a quantification.

Before distributing natural gas, it is cleaned to contain only 5E-4 to 2E-2 weight per cent sulphur to prevent corrosion and any health problems (H<sub>2</sub>S is a poison) problems (Baumbach, 1994, 27 and Table 2.3, p. 28). Therefore natural gas will normally cause really low SO<sub>2</sub> emissions, but the emissions can be higher at the compressor stations of long range transmission pipelines, where sulphur rich gas may be used.

#### *Transport Impacts*

For the transport impacts of natural gas we have aggregated the data given in EC (1995/4, 322) for pipeline construction and treatment operation.

**Table A.65 Occupational health impacts from gas transport and treatment**

Incident type	Figure	Remark
Deaths	4.8 E-10	per MJ
YOLL		per MJ
Major	1.78 E-9	per MJ
Minor	1.07 E-8	per MJ

Sources: EC, 1995/4, 322 and own calculations using an energy content of 39.3 GJ m<sup>-3</sup>.  
YOLL: Years of life lost. Major: Major accidents. Minor: Minor accidents.

#### *Occupational Impacts of Fossils*

Table A.66 shows the aggregated average data for the production of fossil fuels and Table A.67 the equivalent data for the fuel transport. Especially for the coal cycle these values bear a major share of the occupational health impacts.

**Table A.66 Production related accident figures in the fossil fuel cycles**

Accident type	Coal and Lignite	Oil	Petroleum Products
Deaths	0.39	0.02	0.01
YOLL	12.5		0.34
Major accidents	9.57	0.34	0.28
Minor accidents	96.41	3.07	10.10

Incidents per million tons of fuel handled.  
Based on own calculations as described above.

**Table A.67 Transport related accident figures in the fossil fuel cycles**

Accident type	Coal and Lignite	Oil	Petroleum Products
Deaths	0.046	0.16	0.10
YOLL	1.514	5.4	3.5
Major accidents	0.38	0.94	0.56
Minor accidents	16.67	12.4	15.5

Incidents per million tons of fuel handled.  
Based on EC 1995c and EC 1995d.

#### *Average Transport Distances of Imported Fossil Fuels*

From an investigation of the transport length of the fuels imported to Denmark, we have gained knowledge on the average distances and transport modes used for the three fuels: coal, oil and petroleum products (Kuemmel, 1996), Table A.68.

The data indicate that the import of the fuels currently mean a comparatively large emission. This is taken care of in the scenario runs, where such fuel imports are taking place and are included in a total energy chain approach. Normally those emissions are not included in the national statistics.

From an impact point of view it is currently not possible to estimate the damages from emissions taking place at high sea, only near the coasts could such impacts be analysed and investigated.

**Table A.68 Average transport distance of imported fossil fuels**

FuelType	Ship	Barge	Diesel	Electr	Road	Pipe	Belt
Coal	8440	402	216	382	19	0	5
Oil	3471	823	0	0	0	254	0
PetrProd	972	910	0	727	0	29	0

Data average between 1986 and 1995. Source: own computations based on Danmarks Statistik (1987 to 1996).

Ship means large ocean going ships. Barge means small oceangoing ships. Road is road based transport.

Pipe is pipeline transport. Belt signifies belt transport of coal assumed to take place during mining and preparation.

### Passenger transportation technologies

The following section is on transport technologies. This is only included as a database approach, as there have not been assessed the impacts from the transport sector in a very detailed way. Instead we have used the data from other investigations and aggregated them to perform an energy oriented investigation, *i.e.* used the emissions from various energy carriers taking place during the transport process to compute any damages.

Our approach has the disadvantage that changes in impacts resulting from the use of other materials in any future transport sector can not be represented. This could be the case, if steel is being substituted by plastics that lead to completely different emissions and therefore impacts from the process steps. Another important factor are batteries in cars that will be important to store electrical energy in the future scenarios. It is not clear yet, what kind of batteries will be used, and whether they will pose any large environmental problems. Even if the technology will not be different from today's, one may argue that the large scale use of it will lead to recycling schemes, as is already the case for today's car or household batteries.

#### *petrCars*: Private transportation in gasoline or diesel fuelled cars

parameter	value	source	remarks
energy demand	79.1 PJ	DK-EPA, 1995, 4.2.3	
persons transport work	53,615 M pers.-km	DK-EPA, 1995, B.1.1	
transport work	29,799 M veh.-km	DK-EPA, 1995, B.1.1	
total vehicle mass	1,500,000 t	DK-EPA, 1995, B.3.1	
avg. vehicle weight	1 t	DK-EPA, 1995, B.2.2	
lifetime	13 y	DK-EPA, 1995, B.3.1	
spec. energy demand	0.737 kWh/veh.-km		
number vehicles	1,500,000		
occupancy	1,9 pers.-km/veh.-km		
annual driven distance	20,000 km/y/veh.		
<b>Material demand</b>	<b>per vehicle</b>		
Steel	0.75 t	DK-EPA, 1995, B.2.2	
Plastics, rubber, composites	0.225 t	DK-EPA, 1995, B.2.2	
Glass	0.025 t	DK-EPA, 1995, B.2.2	

What is definitely clear is that, if we look at private transport, there will have to be major changes. The scenarios rely on different kind of fuels, and progress is being assumed to lead to much more efficient, *i.e.* less energy intensive, transport carriers, so that emissions from the transport sector will be lower in the future. However, having higher efficiencies will also mean that cars will drive a longer distance for the same amount of energy, so that the impacts that only stem from the distance driven, will be comparatively larger in the future per energy unit of the fuel that is the

case today. When a car drives 100 kilometers on 100 MJ of fuel instead of only 33 kilometres, this also means that it will use the road three times longer, cause three times more congestion and there will be a three times higher accident risk for this same amount of energy.

Unfortunately we could therefore also not perform an investigation of what a larger public transport sector will mean with respect to the total emissions of the transport system.

#### *diesBuses*: Public service-buses or long range-buses

parameter	value	source	remarks
energy demand	7.3 PJ	DK-EPA, 1995, 4.2.3	
persons transport work	9,314 M pers.-km	DK-EPA, 1995, B.1.1	
transport work	486 M veh.-km	DK-EPA, 1995, B.1.1	
total vehicle mass	80,000 t	DK-EPA, 1995, B.3.1	
avg. vehicle weight	10 t	DK-EPA, 1995, B.2.3	
lifetime	10 y	DK-EPA, 1995, B.3.1	
spec. energy demand	4.172 kWh/veh.-km		
number vehicles	8,000		
occupancy	19.2 pers.-km/veh.-km		
annual driven distance	60,750 km/y/veh.		
<b>Material demand</b>	<b>per vehicle</b>		
Steel	6 t	DK-EPA, 1995, B.2.3	
Aluminium	3 t	DK-EPA, 1995, B.2.3	
Plastics, rubber, composites	0.7 t	DK-EPA, 1995, B.2.3	
Glass	0.3 t	DK-EPA, 1995, B.2.3	

#### *bioCars*: Private transportation in biomass fuelled cars

#### *bioBuses*: Biomass fuelled public service buses or long range buses

#### *localPT and regioPT preview*

We have chosen to concentrate on only two groups of passenger trains, local trains, like the Copenhagen area *S-tog* and regional trains, that despite this name also comprise long distance and international trains on the Danish rails. However, the material given by DK-EPA (1995) and from Trafikministeriet (1994) is not detailed enough for this purpose.

**Table A.69 Aggregated data for Danish rail transport in 1990**

parameter	value	source	remarks
energy demand	4.8 PJ	DK-EPA, 1995, 4.2.3	not used here!
persons transport work	4,929 M pers.-km	DK-EPA, 1995, B.1.1	not used here!
transport work	46 M veh.-km	DK-EPA, 1995, B.1.1	not used here!
spec. energy demand	29.0 kWh/veh.-km		not used here!
occupancy	107.2 pers.-km/veh.-km		not used here!
occupancy	67.9 pers.-km/veh.-km	Trafikministeriet, 1994, 76	not used here!
annual driven distance	164,000 km/y/veh.		

Sources: DK-EPA (1995) and Trafikministeriet (1994).

Using data from Nielsen *et al.* (1996a) it is possible to gain more concise data on the average occupancy and energy consumption for the various transport forms. Table A.70 shows the 1995 values for occupancy rate<sup>22</sup> in person-kilometres per vehicle-kilometre, and specific energy consumption in kilowatt-hours per vehicle-kilometre.

<sup>22</sup> Occupancy here means the actual number of people transported and does here not mean the relationship between passengers and seat-kilometres.

**Table A.70 Calculation of average occupancy and energy consumption from independent data for the year 1995.**

type of trains	Ps.-km	veh.-km	transport work		energy. cons.	
	billion	millions	ps-km/v-km		PJ	kWh/v.km
International	198	1829	108			
long distance	1569	9991	157			
regional	1810	24010	75	100	2.6	20.2
S-tog	1207	14416	84	84	2.1	40.5
<b>Sum/Avg</b>	<b>4784</b>	<b>50246</b>		<b>95</b>	<b>4.7</b>	<b>26.0</b>

An explanation for the slight differences in the figures can be found in the development of the occupancy rate which shows a decline by 10.5 per cent between 1990 and 1995, Table A.71, caused by a decline in passenger-kilometres and an increase in vehicle-kilometres<sup>23</sup>.

**Table A.71 Development in occupancy with the Danish State Railways from 1990 to 1995.**

year	1990	1991	1992	1993	1994	1995
<b>bn ps-km</b>	4851	4711	4648	4700	4784	4784
<b>ths. v-km</b>	45620	49370	51046	49936	50437	50246
<b>ps-km/v-km</b>	<u>106</u>	<u>95</u>	<u>91</u>	<u>94</u>	<u>95</u>	<u>95</u>

Source: Nielsen *et al.* 1996.

*localPT*: Trains or metros for local public transport (S-tog)<sup>24</sup>.

parameter	value	source	remarks
energy demand	2.1 PJ	Nielsen (1996a)	
persons transport work	1,244 M pers.-km		based on Nielsen (1996a)
transport work	13.2 M veh.-km		based on Nielsen (1996a)
total vehicle mass	21,000 t	DK-EPA, 1995, B.3.1	
avg. vehicle weight	150 t	DK-EPA, 1995, B.2.4	
lifetime	30 y	DK-EPA, 1995, B.3.1	
spec. energy demand	40.5 kWh/veh.-km		based on Nielsen (1996a)
number vehicles	140		
occupancy	94.6 pers.-km/veh.-km		
annual driven distance	94,000 km/y/veh.		
<b>Material demand</b>	<b>per vehicle</b>		
Steel	75.0 t	DK-EPA, 1995, B.2.4	
Aluminium	45.0 t	DK-EPA, 1995, B.2.4	
Copper	3.8 t	DK-EPA, 1995, B.2.4	
Plastics, rubber, composites	22.5 t	DK-EPA, 1995, B.2.4	
Glass	3.8 t	DK-EPA, 1995, B.2.4	

We shall in our analysis scale our figures of the occupancy rate and energy consumption with the relationships gained in Table A.70. This will give an occupancy rate of 112.6 for regional trains and 94.6 for local trains. We will also scale the transport work of local trains and regional trains by our 1995 data, Table A.70, so that the total transport work 1990 should have been 1244 million person kilometres for local and 3685 million person kilometres for regional trains. As a last reminder we have to mention that number of vehicles for trains here does not mean cars, but trains, and the occupancy relates to an average train and not to one car.

<sup>23</sup> As noted before our occupancy does not per se indicate a lower occupancy rate with regards the available seats.

<sup>24</sup> The data for regional trains and local trains (S-tog) are only given aggregated in DK-EPA (1995) and so we made a simple 50/50 split to compute the data, therefore the figures for both transport modes are the same.



**regioPT: Trains for regional and international public transport<sup>24</sup>.**

parameter	value	source	remarks
energy demand	2.6 PJ		based on Nielsen (1996a)
persons transport work	3,685 M pers.-km		based on Nielsen (1996a)
transport work	32.8 M veh.-km		based on Nielsen (1996a)
total vehicle mass	56,000 t	DK-EPA, 1995, B.3.1	
avg. vehicle weight	403 t	DK-EPA, 1995, B.2.4	
lifetime	30 y	DK-EPA, 1995, B.3.1	
spec. energy demand	20.2 kWh/veh.-km		based on Nielsen (1996a)
number vehicles	140		
occupancy	112.6 pers.-km/veh.-km		
annual driven distance	234,000 km/y/veh.		
<b>Material demand per vehicle</b>			
Steel	322.4 t	DK-EPA, 1995, B.2.4	
Aluminium	9.1 t	DK-EPA, 1995, B.2.4	
Copper	4.0 t	DK-EPA, 1995, B.2.4	
Plastics, rubber, composites	60.5 t	DK-EPA, 1995, B.2.4	
Glass	4.0 t	DK-EPA, 1995, B.2.4	

*plane*

Planes for (inter)national passenger transport are mostly (DK-EPA, 1995, B.2.3) being used on middle distances like between Scandinavia and Europe. The typical weight of these machines is assumed to be between 30 and 40 tons with an capacity of about 100 passengers as like a DC-9. We shall not develop a finer graduation of aeroplane classes here but suffice with these average values. A more elaborate description of plane types and their fuel characteristics can be found in Nielsen (1996a).

parameter	value	source	remarks
energy demand	1.4 PJ	DK-EPA, 1995, 4.2.3	
persons transport work	1,476 M pers.-km	DK-EPA, 1995, B.1.1	
transport work	25 M veh.-km	DK-EPA, 1995, B.1.1	
total vehicle mass	1,100 t	DK-EPA, 1995, B.3.1	
avg. vehicle weight	35 t	DK-EPA, 1995, B.2.3	
lifetime	20 y	DK-EPA, 1995, B.3.1	
spec. energy demand	15.556 kWh/veh.-km		
number vehicles	31		
occupancy	59 pers.-km/veh.-km		
annual driven distance	806,000 km/y/veh.		
<b>Material demand per vehicle</b>			
Aluminium	26.3 t	DK-EPA, 1995, B.2.3	
Steel	3.5 t	DK-EPA, 1995, B.2.3	
Plastics, rubber, composites	3.5 t	DK-EPA, 1995, B.2.3	
Titanium	0.9 t	DK-EPA, 1995, B.2.3	
Magnesium	0.9 t	DK-EPA, 1995, B.2.3	

**Goods Transport Technologies***petrVan*

According to data from the Danish Environmental Department (DK-EPA, 1992) and the Danish Transport Ministry (Transportministeriet, 1994) the following data, Table A.72, have been collected to describe the current core data for small goods vehicles (Gasoline fuelled vans (LPV)

< 3.5 t) where we have assumed that the material data for cars are valid for this class of vehicles, too.

**Table A.72 Petrol fuelled vans**

parameter	value	source	remarks
energy demand	25.5 PJ	DK-EPA, 1995, 4.2.3	
capacity	0.1 t-km/veh.-km	Trafikministeriet, 1994, 76	
total vehicle mass	356,000 t	DK-EPA, 1995, B.3.1	
goods transport work	469 M t-km	DK-EPA, 1995, B.1.1	
transport work	4904 M veh.-km	DK-EPA, 1995, B.1.1	
avg. vehicle weight	1 t	DK-EPA, 1995, B.2.2	
lifetime	10 y	DK-EPA, 1995, B.3.1	
spec. energy demand	1.444 kWh/veh.-km		
number vehicles	356,000		
annual driven distance	13,375 km/y/veh.		
<b>Material demand</b>		<b>per vehicle</b>	
Steel	0.75 t	DK-EPA, 1995, B.2.2	
Plastics, rubber, composites	0.225 t	DK-EPA, 1995, B.2.2	
Glass	0.025 t	DK-EPA, 1995, B.2.2	

#### *bioVan*

Biofuelled vans (LPV) will become a future technology. Basically the data for petrVan apply, but the specific demand should be lower.

**Table A.73 Biogas fuelled vans data sheet**

parameter	value	source	remarks
avg. vehicle weight	1 t		
lifetime	10 y		
spec. energy demand	0.73 kWh/veh.-km		
annual driven distance	15,000 km/y/veh.		

#### *diesLorry*

According to data from the Danish Environmental Department (DK-EPA, 1992) and the Danish Transport Ministry (Transportministeriet, 1994) the following data, Table A.74, have been collected to describe the current core data for diesel fuelled lorries (HPV).

**Table A.74 Data for energy and material consumption of diesel fuelled lorries.**

parameter	value	source	remarks
energy demand	18.8 PJ	DK-EPA, 1995, 4.2.3	
capacity	6.8 t-km/veh.-km	Trafikministeriet, 1994, 76	
capacity	5 t-km/veh.-km	DK-EPA, 1995, B.2.2	not used here!
total vehicle mass	604,000 t	DK-EPA, 1995, B.3.1	
goods transport work	10,195 M t-km	DK-EPA, 1995, B.1.1	
transport work	1388 M veh.-km	DK-EPA, 1995, B.1.1	
avg. vehicle weight	4 t	DK-EPA, 1995, B.2.2	
lifetime	10 y	DK-EPA, 1995, B.3.1	
spec. energy demand	3.483 kWh/veh.-km		
number vehicles	151,000		
annual driven distance	10,000 km/y/veh.		
<b>Material demand</b>		<b>per vehicle</b>	
Steel	3.2 t	DK-EPA, 1995, B.2.2	
Plastics, rubber, composites	0.4 t	DK-EPA, 1995, B.2.2	
Aluminium	0.4 t	DK-EPA, 1995, B.2.2	

There is necessarily some development going on with diesel fuelled engines as public awareness of the emissions from the transport sector has been rising and especially as a number of deaths have been related to particle emissions from diesel engines (Anonymous, 1996; Masood, 1996; Masood, 1996b; Transportrådet, 1993; Trafikministeriet, 1994).

A possible solution to reduce especially the particle emissions of diesel engines is described in Mrasek (1996). Accordingly it is possible to prevent the creation of carbon (soot) simply by injecting the fuel at higher pressures than is currently the case (1500 to 2000 bar compared to currently below 1000 bar). This trick speeds up the burning of the carbon that anyway takes place so that carbon emissions are being reduced to around the current technical measurement limits.

The current initiatives, as given by the European Union's commissions proposal for a new, enhanced, transport directive, to reduce the carbon emissions from 80 milligrams to 40 milligrams per vehicle-kilometre will, however, not yet necessitate in the application of this technology. Those limit values can still be reached with traditional carbon filters or external after-burners (Mrasek, 1996).

It seems, though, evident to include such technological advancement in the future transport scenarios, both as society will very probably demand an inclusion of such measures to diminish transport related emissions and as liquid fuels still can be expected to be used in parts of the road based transport sector, like rape-oil fired lorries and heavy load vehicles, where those problems occur currently, too (see under bioLorry).

#### *bioLorry*

Biofuel, like methanol, or biogas fuelled lorries and other machines, for example used in the building sector (HPV)

As a first approximation we can use the data from Ekelund (1994) to estimate emission factors for biogas fuelled lorries that could take part in future goods transport (actually these figures also apply to future bus engines).

**Table A.75 Emission data for biogas or methane fuelled adapted diesel engines**

Species	g/kWh		
CO	0.21	Ekelund 1994, 335	(0.21-1.0); goal: 2.0
HC	0.9	Ekelund 1994, 335	(0.9-1.11); goal: 1.0
NO <sub>x</sub>	0.79	Ekelund 1994, 335	(0.79-2.97); goal: 2.0
Particles	0.02	Ekelund 1994, 335	goal: 0.1

Source: Ekelund (1994).

**Table A.76 Ship data**

parameter	value	source	remarks
energy demand	3,000 MJ/veh.-km	Kuemmel, 1996	
capacity	100,000 t	Kuemmel, 1996	
lifetime	16 y	GENERIC.PRC	
annual driven distance	80,000 km/y/veh.	GENERIC.PRC	
<b>Material demand per vehicle</b>			
Steel	20,000 t	GENERIC.PRC	
energy demand	450 MJ/veh.-km	Alexanderson <i>et al.</i> , 1991	
capacity	2,500 t	Alexanderson <i>et al.</i> , 1991	
lifetime	20 y	GENERIC.PRC	
annual driven distance	60,000 km/y/veh.	GENERIC.PRC	
<b>Material demand per vehicle</b>			
Steel	1,000 t		

*ships*

The TEMIS database is equipped with two generic ship technologies. We have decided to include two technologies of our own, a bulk carrier and a coaster like ship. The basic data for the two are given in Table A.76.

All the ships are fuelled with bunker oil with 3 weight per cent sulphur, which means that they cause rather high emissions. But those occur mostly over the seas and therefore it is very difficult to assess the actual damage values. As a first approximation one could use the value for land based emissions but this could be an overestimate.

*industry*

Industry comprises various industrial energy conversion processes which are difficult to generalise.

We assume that the predicted increases in energy end-use efficiency will continue in the future as has been described in the final report on industry's saving potential by the ISI-institute as a subtask in the LTI-project on the long term integration of renewables in the European energy system (Radgen and Tönsing, 1995).

In this project we will therefore not explicitly elaborate on the developments in industrial energy consumption. In any case any shifts in the production, as necessitated by the change of the present energy system to any future one, will be implicitly included in the life-cycle computations, simply by the choice of new energy conversion chains.

On the other hand we will not be able to explicitly elaborate the changes in the choice of processes in industry for material conversions. New processes might take place, and such technological changes can mean a lot for the technical development, and it is clear that the technologies used today will over a longer period reach their limits with regards energy efficiency.

One factor that needs to be taken care of anyway, is the actual amount of work that can be gained from a specific energy form, the notion of exergy. Better exploitation of the primary energy input can be reached by coupling of different processes that would open savings potentials of theoretically up to 50 per cent (Radgen and Tönsing, 1995, 12).

*Energy efficiency ("ratio")*

Rational energy use is not a generation technology *per se*, even though it has been quoted as delivering *Negawatts* as it saves an extra demand of end-use energy and so can be perceived as a generating capacity. This also will reduce direct emissions from the conversion systems. Nevertheless, rational energy use has indirect effects from the production of *e.g.* extra energy saving circuits, too. Those impacts are not described well and literature is very sparse with that regard. We have, however, found some data for the energy balance of insulation materials, for reducing space heating demand, as this is a rather well-investigated area, see the section on material conversions.

**Material Conversions**

In this part of the study we shall shortly describe the technological development with regards the materials that are being used in the energy cycle. We concentrate on steel, aluminium, cement (for concrete production) and insulation materials.

## Electricity Supply System

The electricity supply for material production is given in the following two tables. The present electricity generation mix is taken from Schmidt *et al.* (1994). This mix therefore gives the environmental impacts from electricity generation for the present material production. The abbreviations of the technology are understandable, the first parameter gives the fuel, ST stands for steam power plants, we have chosen the German data in most cases, except for run-of-the-river (ROR) hydropower plants, that are from GEMIS (1992) on an ideal Russian power plant of this kind.

**Table A.77 Present European electricity mix**

energy dispatcher	share in %
lign-PP-ST	10.50000
hcoal-PP-ST-G-mix	18.30000
oil-H-PP-ST-G	9.600000
gas-PP-ST-G	9.500000
nuclear-power-G	36.20000
Hydro-PP-ROR-big	15.20000
waste-PP-ST	0.350000
wind-PP-medium	0.350000
sum	100.0000
Current European electricity generation mix	

The future energy system for European material production has been taken from the fair market scenario, where the future German values are being used. This scenario rests on renewable energy sources throughout, it has a large share of solar PV electricity (solar-PV-poly.CdTe-G) and of wind power. In the EFP2030 scenario the *el-export-DK* post is substituted by an equivalent electricity mix, with impacts arising outside Denmark then (not shown explicitly).

**Table A.78 Future electricity generation mix**

energy dispatcher	share in %
solar-PV-poly-CdTe-G	11.80000
wind-PP-med-ExternE	2.800000
wind-PP-large	5.400000
Hydro-PP-ExternE	2.100000
hydro-PP-micro-new	0.300000
fuel-cell-2030	12.40000
bonus-el-prim	9.800000
el-export-DK	55.40000
sum	100.0000
Electricity mix in DE 2030 from LTI	

### *Steel*

The steel production has been progressing from open hearth steel mills over blast furnaces to electric arch furnaces, the latest of which can be filled with both iron ore, either as pellets or in pulverised form, or with scrap metal. This technology opens up for recycling of steel structures, although care has to be taken when choosing ones sources of metal scrap as certain other metals and substances like copper only may occur in traces, and this necessitates a more careful handling of the steel scrap (Müller and Gregersen, 1995, 19).

The primary energy demand for steel generation varies depending on the technology level and the sources. We give a short overview over published values for generating one metric ton of steel, or iron where appropriate:

**Table A.79 Steel and iron production energy demand (GJ per ton)**

Source	Technology	Energy demand	Comments
DK-EPA, 1995, B.-2.2	steel products	33	"valset" steel
Lownie 1973, 103	steel products	35	3700E12 BtU/110 Mt steel products
Lownie 1973, 103	raw steel	26	3700E12 BtU/150 Mt raw steel
Lownie 1973, 103	steel products	30	-15 % in US steel products production
Lownie 1973, 103	raw steel	22	-15 % in US raw steel production
OECD 1989a, 36	electric arc raw steel	<10	scrap-fed mini mills
Müller and Gregersen 1995, 9	el. arc based raw steel?	16	secondary steel (using scrap)
Müller and Gregersen 1995, 9	blast furnace based ?	33	primary steel (from ore)
Fischer <i>et al.</i> 1988, 298	Mexican production mix	21	5.1 GCal/t
OECD 1989a, 38	el. arc	15.5	ES (el. arc production)
OECD 1989a, 38	el. arc	17.6	NL (75/25 oxygen/el. arc production)
EC 1995/6, 88 ff.		22	22.2 delivered 26.7 primary energy demand in UK steel mix
Rasmussen, 1974, 95	SM oven, DDS	2.2	7 t fuel oil for 130 t steel from scrap
Müller and Gregersen 1995, 97	electric arc	1.6	50 MWh to melt 110 t steel
Hogan 1984, 108	electric arc	1.7	490 kWh/t
<b>iron</b>			
Eketorp 1976, 42	blast furnace	16	c. 550 kg coal. Lowest techn. limit deemed possible
Eketorp 1976, 42	blast furnace	24	c. 800 kg coal. Existing technology
OECD 1989a, 37	blast furnace	>18	conventional integrated mills
OECD 1989a, 37	blast furnace	19	Korea or Taiwan
OECD 1989a, 36	blast furnace	13	NL, 423 kg coke/t @ 30GJ
OECD 1989a, 35	blast furnace	12	c. 490 kg coal falling rapidly with pulverised coal injection

As one can see the data for steel and iron production span a very broad range. None of the texts mentioned in Table A.79 does give explicit explanation whether the energy consumption for iron and steel is in primary or delivered energy.

**Figure A.5 Steel parts production with upstream processes**

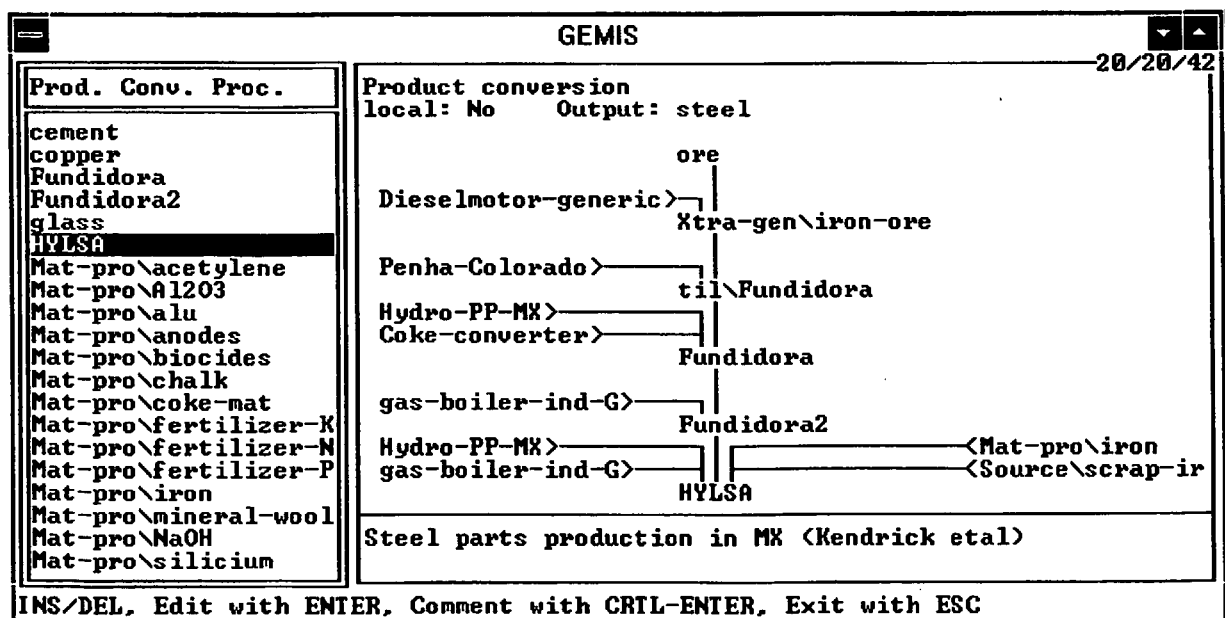

We have therefore chosen to use the data from a publication on the Mexican steel industry (Kendrick *et al.*, 1984) as we have there given the data for the delivered energy supplies and their quality, Figure A.5. This gives us the opportunity to generate figures that we can feel comfortable with. Another advantage of using the information from Kendrick *et al.* (1984, 175 ff.) is that they describe a complete production chain for steel parts production. This is important for our purposes, too, as we actually want to use data for steel parts and not just for steel ingots as basic material in our database. We use their data on pellet production in Fundidora (Kendrick *et al.*, 1984, 185) and the actual steel production at HYLSA (do, 189).

**Table A.80 Input Output matrix for Mexican steel production**

Species	Input	Output	Input	Output	Input	Output	Site
Scrap	1526						Fundidora
Coke	1345						
Lump ore	2515						
Concentrated ore	1822						
Natural gas MNm <sup>3</sup>	216						
Electricity GWh	391						
Pellets		1322					
Pellets			1322				
Natural gas MNm <sup>3</sup>			517				DRU
Sponge iron				959			
Sponge iron					959		Hylsa
Scrap					123		
Electricity GWh					724		
Steel						808	

Source: Kendrick *et al.* 1984, 175 ff., own calculations.

Save for electricity and natural gas figures given in kilotons per year.

DRU: natural gas fuelled direct reduction unit.

There is a trend towards recycling more steel than has been the case in the past, and this development means that we also have to include a so-called electro-steel process which according to GEMIS (1992, 134) necessitates an electricity demand of 1.8 MJ/kg and heat demand of 0.4 MJ/kg. We assume that the electricity is produced in tropical hydropower installations, and that the process heat is provided by industrial gas boilers.

The values gained from Kendrick *et al.* (1984) have been used in the GEMIS programme for the calculation of the emissions related to primary steel production. It has been assumed that today 90 per cent of the steel used in steel parts originate from primary steel production, while 10 per cent are produced by the electro-steel process. For the two future scenarios this relationship is assumed to be opposite to today's, so that the major part of the steel will be produced from recycled steel scrap.

### *Aluminium and Copper*

We describe the production of aluminium and copper for an analysis of the related emissions and impacts from their production.

Aluminium is produced via a two step process, whereby first alumina is produced that then is transformed into aluminium. The primary energy demand for aluminium generation is rather high, though not as high as for other light alloys like magnesia or titanium. Aluminium production is more and more taking place in Third World countries, where access to cheap hydropower is essential for the production process.

On the other hand the regions where viable bauxite reserves exist are normally very flat due to the genesis process of this bauxite (Bunker, 1995, 268 f.). Therefore when those reserves shall be exploited the related hydropower dam becomes extremely long with massive thick walls. This leads to the flooding of enormously large areas to make up for the small falling height over the dam itself. And as many host countries calculate with spin off effects of those projects this further enhances the dimension of the hydropower projects. The low prices of this commodity as a consequence of supplies that are not balanced by demand have sharpened this situation.

Besides the direct costs of such hydropower aluminium combinations there are other costs brought about by the isolation of viable sites from traditional centres of economic activity. Extra costs for transport energy and residential infrastructure are in the range of 60 to 70 per cent of the total costs, of which a major share is currently borne by the developing country (Bunker, 1995, 283).

As a result the production of aluminium is environmentally a very damaging process. The large hydropower installations lead to high emissions of methane from the hydropower installations. We have before mentioned that those hydropower installations cause methane emissions that are of the same magnitude as for fossil fired power stations and will use the value for tropical hydropower installations for the emissions related to aluminium production, see under hydropower.

With respect to copper production basically the same thing applies, in that the area demand for the production is high, and that the production will cause rather grave environmental impacts on the environment. A reason for this is the use of acids in the production process, whereby large spills can be caused that are harmful to the environment. Also the energy demand for copper refining is large, and therefore other indirect effects, too.

A way of reducing the impacts from metal production is the recycling of those metals. This is done to varying degree with respect to copper and steel, but it necessitates the separate collection of the metals, and production processes that enable easy segregation of the parts containing different metals. Also this has to be transferred to alloys that have to be treated carefully. Currently copper is not always recycled separately, as it is contained in various steel-made structures and is not removed before melting. With respect to aluminium recycling is somewhat easier, although there are applications where nonrecoverable fractions are generated.

### *Cement*

According to the data given in the TEMIS program a tonne of cement currently (Figure A.6) necessitates a total primary energy consumption of 7.6 gigajoule and leads to the emission of 0.1 kg SO<sub>2</sub>, which mostly stem from the excavation of raw materials, and 906 kg CO<sub>2</sub> of which 500 kg originate from the cement production. In the future only a primary energy demand of 5.4 GJ will be necessary, SO<sub>2</sub> emissions will rise to 0.7 kg, but CO<sub>2</sub> emissions fall to slightly more than 500 kg (Figure A.7). Both these trends are a result of the substitution of natural gas with biogas and other renewable energy sources, which as biogenic energy carriers have no direct CO<sub>2</sub> emissions, but in the data set it is assumed that biogas contains 0.2 per cent H<sub>2</sub>S, which is more than in natural gas, where the TEMIS database gives a value of 5E-4 per cent.

### *Insulation Material*

The current Danish insulation market is a multi billion business, and insulation is very important for the scenarios, where it is assumed that the heating energy demand is going to go down greatly to achieve the energy savings that are necessary to reduce the total primary energy consumption. It therefore is essential also to give a short presentation of the materials that are available for insulation practices and if possible to describe their environmental effects.



Figure A.6 Current process chain for cement

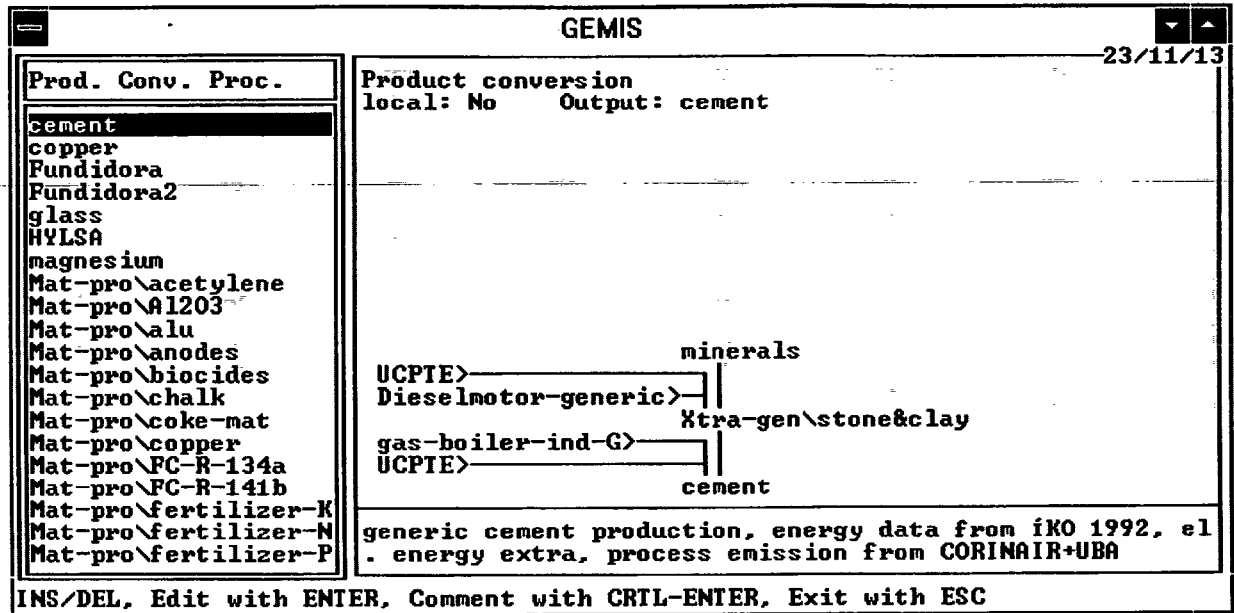
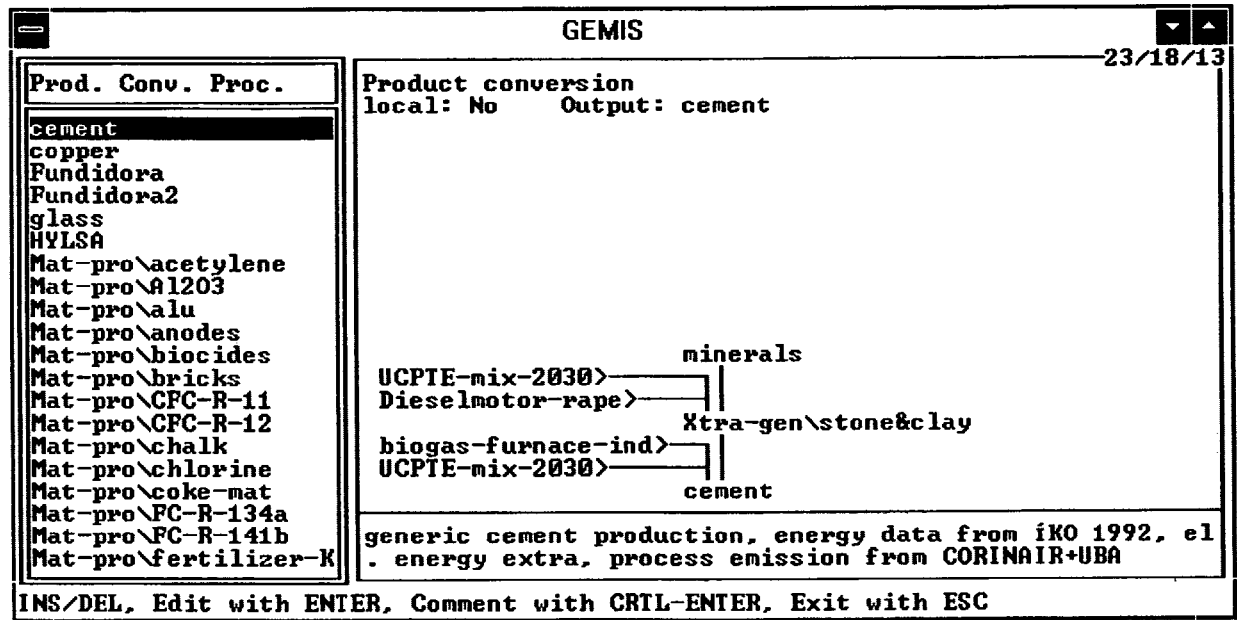

Figure A.7 Future process chain for cement production



We have been provided with some data from a major manufacturer of stone wool products (Clausen, 1996) and from a group of trade union representatives in the building sector (BAT, 1996) on three alternative insulation products, expanded polystyrene, perlite and a paper based granulate plus the two different kinds of mineral wool. Furthermore we got some information from the producer of Cemskum (Lund, 1996).

*Information Limits*

It is important to note here that our presentation may be influenced by the way the material has been chosen to be presented, and that other alternative insulation materials and techniques may

exist that we are ignorant of and that therefore have not been assessed at all. When part of the building union representatives made public the existence of alternative insulation materials other than stone wool or glass wool it was to put emphasis on the problems relating to the work environment of their members. Especially acute are the problems with irritated skin and visible obstructions of the upper respiratory parts from the fibres that the workers are afraid of.

The argumentation is built on the fibre content of the mineral wool material, and that there is reason to believe that those fibres can do harm to workers health, and maybe also to people exposed to them from damages in the building shell that lead to leakages of those fibres into the air. The arguments are similar to the asbestos discussions during the 1970s and 1980s, and that led to the abolition of those products except for certain very limited applications, where substitutes were not available.

We cannot in this study treat the question of the health hazards that may arise from the production and application of the different materials in a rewarding way. As mentioned before, this matter can not be investigated further due to lack of relevant data material, with respect to the small producers of the new insulation materials that only have a small share in the total insulation market, and therefore may not be applying representative technologies so that statistically significant data will not be available. On the other hand we are not aware of statistically significant data of the larger classical producers, even though we presume that such investigations have been made or are already initiated. Therefore we leave this aspect out of the following discussion and concentrate on the energetical aspects and the impacts on the environment.

#### *Why Insulation?*

To have a comfortable micro climate humans have always made use of existing or man-made structures. Caves and furs were supposedly the first places that humans discovered, that could help prevent too large heat loss during the winter time, when the human settlement left the relatively comfortable origin of the tropical and subtropical regions. But even though such places help to create better microclimatic conditions than having to stay outside, completely exposed to the different forms of weather, they are not the most ideal places to live in. First their number is limited, second they are not always situated, where food can be found.

Today we live in houses over most places of the World, and in many cultures the use of air conditioning has begun to make houses' design of minor importance. But the climate still determines a lot how the building shells are formed, and badly adapted houses cause higher costs for acclimatisation for the inhabitants as a consequence.

In Denmark the average climate is mild, with a yearly average temperature of about 7 degrees Centigrade, with July temperatures of on average 15 °C and January averages of 0 °C. These averages are not giving a true picture of the extreme conditions that can occur in both directions: to warmer and colder situations. But they give the basic reason for the high energy demand that people have in the middle and polar latitudes to create comfortable living conditions, which in those regions basically means space heating during the winter and parts of the year with cold conditions.

Now the energy demand for creating comfortable conditions depends on the space that a person occupies during work, leisure and spare time; the state of the building shell, *i.e.* whether it allows any possible passive solar heat amount to become useful for the inhabitants, how much the inside air is exchanged with the exterior and whether heat recovery is applied or whether draught is removing heated air and leading cold air from the outside into the building, and how well the building shell is transferring heat by conduction to the outside.

In order to reduce the energy demand for space heating (these arguments basically also apply for air conditioning during warm periods) one has to limit any draught, which currently does not pose technical problems and reduce the energy transfer to the outside by the building shell. This latter point can be reached by insulation, which means that the transmissivity of the building shell is being reduced.

#### *Presentation of Various Insulation Materials*

As indicated before we will extend the investigation of the various insulation materials by an analysis of the energy balance of those, where we use the data we have at our hands. We start by a short presentation of the various insulation materials. All products are being transported by train or truck to the application sites, so we do not specify this explicitly. All the materials that we have presented have certain advantages and faults. Therefore we give a short analysis of them.

*Perlite*<sup>®</sup> is the name of a volcanic stone which volume expands under heating up to 20 times. The raw material is brought to Denmark from mines in Greece and Turkey in ships of 1000 to 3000 tons. The production is taking place in Denmark, and the product can be emptied from sacks or blown into the hollow building shell. It may be recovered and recycled, if it is kept separate from other building material. The dust from Perlite or its antifouling treatment is not classified as dangerous. (BAT, 1996, 47 ff.)

Although perlite uses a volcanic stone as raw material we assume that exhaustion of this resource will not play a large role under large scale introduction of this material in insulation technologies. Furthermore the open mines used for extraction of perlite have to be re-established after the mines' exhaustion (BAT, 1996).

*Styropor*<sup>®</sup>, or *Expanded Polystyrene* (EPS) is made from crude oil or natural gas, but there is no raw material production in Denmark. The raw materials, styrene, which is dangerous to human health, and pentane are being produced in refineries with the common environmental consequences that causes. Via different process steps small polystyrene balls are being made that will expand once they are heated due to their pentane content and fill out a form. Those processes are taking place in closed systems so that human exposure is minimised. The expanded styrene balls can be blown directly into hollow spaces but will normally be transformed to larger EPS blocks of up to 6 m<sup>2</sup>. (BAT, 1996, 50 ff.)

EPS parts can be used, where mechanical strength is required, e.g. under roofs where one can walk on<sup>25</sup>. Rests during construction can be collected and recycled, but what can be recovered during renovation and tearing down of old buildings will normally be too polluted and can not be recycled. With respect to raw materials the problem of resource exploitation occurs. EPS is inflammable, which is its biggest disadvantage. When it burns it releases large amounts of black smoke, but also ca. 800 MJ m<sup>-3</sup>. There will be emissions of pentane, which is a NMVOC, from the production process to the air.

*Paperwool* is being made from old newspapers that are being collected in a region in Denmark in a mill near Hillerød north of Copenhagen. The paper is being cut into small fibres, which are being impregnated with a salt mixture to reduce flammability. The salt mixture is basically aluminium-hydroxide and borax (Na<sub>2</sub>B<sub>4</sub>O<sub>7</sub>·10H<sub>2</sub>O) which are being transported to Denmark from Hungary in trucks. As paper wool can absorb and release water, there is opposite to other materials no need to keep the insulation protected from normal exposure of moisture. There can be a large dust exposure during installation, and the staff has to wear proper protection, although in 80 % of the instances dust exposure is negligible. The product can be recycled or re-used in horticulture or

<sup>25</sup> But polystyrene can not be used for insulation when temperatures of 40 C are exceeded as in heat storage tanks.

for other industrial products. Attempts are being made to substitute the minerals salts with plant based substances and to reduce the dust liberation during production and use. (BAT, 1996, 55 ff.)

Although paper wool is difficult to ignite, its use has been hampered by the Danish building code that requires the use of non-inflammable products. This will currently diminish its applicability. It also has the disadvantage of dust and fibre release under certain applications. This problem seems to be solvable by protection. But its great advantage is the low energy demand for its production, as will be shown below. Therefore it could encounter larger markets in any future situation, where energy prices were higher than today. The question remains, whether the fibres can be released from insulation by the pump effect on loose floors.

The cement based foam, *Cemskum*<sup>®</sup>, is made by blending a component into a water-cement mixture that then will start to expand and fill out hollow spaces around it. During this process *Cemskum* is liquid as water, so it has to be ensured that there are no cracks in the forms or the parts that shall be insulated. Also hydrogen is liberated. So it is essential that no ignition occurs, and that the staff does not smoke. It will take about a day for the final product to harden, and a few weeks before it is dry. *Cemskum* can be used in constructions as a bearing element with high insulation capacity, as the small air bobbles within the material reduce heat transmission. As with paper wool *Cemskum* is open to water vapour diffusion, so walls made of this substance could "breathe". There are several projects going on in Denmark, where *Cemskum* has been used to substitute mineral wool products for technical insulation at high temperatures in e.g. power stations or for industrial processes<sup>26</sup>. A device to prepare the product automatically, instead of manually as is the case today, is being developed. (different material from Lund, 1996)

*Cemskum* will probably be applied in industrial processes, where temperatures are high, as in power stations, where the pipes that convey warm water or steam have to be insulated against energy losses. This will probably not be the case for so many industrial processes in the future, as emphasis will shift from the heavy industrial sectors to more advanced sectors in nanotechnology, genetic engineering and other more specialised industries with moderate demand for high temperature process heat. But it might even be a good choice for current and future power stations based on fuel cells working at higher temperatures. And it might be useful to create seasonal heat storage systems in regions where the soils are water permeable, or the ground water table is too high to allow the construction proposed by Wesenberg *et al.* (1991). We do not know the composition of the additive that leads to the cement foam creation, and assume that it is an oil-based substance with the energy demand for its production given by the data found in the GEMIS database.

*Glasuld*<sup>®</sup> and *Rockwool*<sup>®</sup> are the two mineral fibre products that are established internationally. In both products the insulating capacity is being reached by keeping a large amount of air stable by a small amount of fibres. Glass wool is made from glass that is being molten and pressed into fibres of various lengths, which are then bound by bakelite and covered with an oil emulsion to prevent water uptake and dust release. During hardening there are releases of phenol, formaldehyde, ammonia and NMVOCs. Glass wool cannot be used for fire insulation. Stone wool is being made of molten diabas, a special mineral which is imported from Sweden, plus some other ingredients and with the same binder as for glass wool. It can be produced to become not inflammable. Neither of both substances can be re-used at renovation or tearing down, as they are not clean enough. Furthermore they tend to spoil other materials, and concrete containing such fibres can currently not be recycled. (BAT, 1996, 58 ff.)

<sup>26</sup> According to Lund (1996) the high temperatures in e.g. power station steam pipes tend to burn the binders from mineral wools, so that they have to be exchanged about every two years or so. This costs a lot, as the resumes of the mineral wool have to be handled at extreme care and have to be treated as special waste. A *Cemskum* insulation can last up to about 20 years, and the removal is not that hazardous.

Mineral wool products are currently determining the insulation material market. They are being produced with a large energy demand, but as further investigation will show their application also saves much energy. Certain stone wool products offer the advantage of fire stability, and therefore will probably be used in markets where this feature is important. The fibre problem and the work environment impacts are issues that need further investigation, especially as mineral fibres have been included in a list over cancerogenous substances by the Danish work health authorities.

#### *Insulation Materials Energy Balances*

Insulation material has to be produced at an economical, but also at an energetical cost. Table A.81 gives data on the energy demand for production of an insulation material and the amount of energy that can be saved by insulation practices that have become feasible in the last decades.

**Table A.81 Energy balance for typical insulation practice**

Insulation Thickness (mm)	Energy used in Production (kWh)	Energy Use over 20 Years (kWh / m <sup>2</sup> .yr)	Energy Loss through Building Shell (kWh / m <sup>2</sup> .yr)	Total Energy Balance (kWh / m <sup>2</sup> .yr)
0	0.0	0.00	119.0	119.00
100	11.6	0.58	23.0	23.58
200	23.2	1.16	12.0	13.16
300	34.8	1.74	9.0	10.74
400	46.4	2.32	6.9	9.22
500	58.0	2.90	5.5	8.40
600	69.6	3.48	4.8	8.28
700	81.2	4.06	4.4	8.46
800	92.8	4.64	4.2	8.84

Source: Clausen (1996). The data on the energy demand for the production of the insulation material refer to a Danish mineral wool product around today. They have improved slightly over the latter years. The original data are from a *Rockwool Isoleringshåndbog* which came out in 1979.

It can be seen that from the data given in Table A.81 it would be energetically sound to increase insulation thickness to about 60 centimetre, which is much more than what current building codes demand, or current building practice is experienced with. It also is questionable whether economic considerations would support such demands. Still zero energy houses are feasible, and have been built, also in Denmark (?), and in those cases very thick insulation ensures that heat demand normally can be covered nearly exclusively by the inhabitants heat flow and passive energy gains from electrical appliances, etc.<sup>27</sup>.

When we look at the energy demand for the production of the different insulation materials, it is necessary to look at the volume and not the mass of those products. Insulation is working by keeping heat from being transferred, and this is reached by having a large volume. As the density of the final products can vary, it is important to look at a unit volume.

Table A.82 shows the energy consumption for production, and where available transport of the finished material and raw materials, of one cubic metre (m<sup>3</sup>) of the four different materials respectively. As we can see there is a factor of almost 30 between the total energy demand for producing one cubic metre of Paperwool with the lowest and Cemskum with the highest value. There also are differences in the environmental impacts from the production of the materials, but the fact that there are given many of such for EPS and the two mineral wool products is probably only a result of more intensive investigations on those. We do have to remember that the other three products are still very new ones on the Danish market.

<sup>27</sup> In very severe winters the need might arise to use a wood fired oven.

As Table A.82 indicates from a current energy analysis the products Paperwool and Perlite seem to have some advantages to the mineral fibre products on the area of residential applications. They have the same thermal conductivity, which means that the same thickness and volume will insulate equally well. We therefore have chosen to determine a product LCA of those substances compared to the other traditional products, especially with respect to possible impacts from the transport of the raw materials or secondary ingredients.

**Table A.82 Energy and environmental data for different kinds of insulation materials**

material	Paperwool	Perlite	EPS	Glasuld	Rockwool	Cemskum
remarks	dust mask required, no H <sub>2</sub> O vapour stop needed	dust, blowable, heat and fire resistant	blowable, ignitable	fibre problems	fibre problems	expanding, heat resistant
basic material	newspaper	Perlite	polystyrene	broken glass	diabas	cement
secondary material(s)	Al-hydroxide (9%), borax (3%), boric acid (3%)	Si-resin		bakelit-resin (4-12%) mineral oil (1%)	bakelit-resin (1.5-4.5%); mineral oil (1%)	additives
density (kg m <sup>-3</sup> )	28	80	20	18	30	230
<i>corrected mass (kg)</i>	28	80	25	24.75	29.25	425.5
therm. conductivity (W/m.K)	0.04	0.04	0.05	0.055	0.039	0.074
<b>total energy use (MJ m<sup>-3</sup>)</b>	<b>81<sup>28</sup></b>	<b>325</b>	<b>1280<sup>29</sup></b>	<b>500?</b>	<b>400?</b>	<b>2125</b>
production energy (MJ m <sup>-3</sup> )	17	240	180	500	400	2125 <sup>30</sup>
raw material transport energy (MJ m <sup>-3</sup> )	13 <sup>31</sup>	85	1100			
raw material transport distance (km)	6	6300	6300	1400?	1400?	50
secondary material transport distance (km)	1400					200 <sup>32</sup>
<b>Emissions during and after production (kg tons<sup>-1</sup>)</b>			C <sub>5</sub> H <sub>12</sub> (16.6?); styrene (?); solid waste (3.1)	fibre-rests (1); HCHO (0.07); phenol (0.1); NH <sub>3</sub> (1)	phenol (0.3); HCHO (0.3); NH <sub>3</sub> (3-4); HC (4)	H <sub>2</sub> (?)

Source: BAT 1996; Lund 1996; Clausen 1996.

*corrected mass*: used to compare the insulation materials by calculating the mass that would give the same insulation capacity as one cubic metre of Paperwool.

From a simple energy analysis, see Table A.82, the products Paperwool and Perlite seem to have some advantage to the mineral fibre products in the area of residential applications. They have the same thermal conductivity, which means that the same thickness and volume will insulate equally well. We therefore have chosen to determine a product LCA of those substances compared to the other traditional products, especially with respect to possible impacts from the transport of the raw materials or secondary ingredients.

Before we start to present the results of this PLCA we have to correct for differences in the qualities of the materials. The thermal conductivity describes how well the products, while still

<sup>28</sup> including energy demand for office space!

<sup>29</sup> Burning EPS will liberate about 800 MJm<sup>-3</sup>.

<sup>30</sup> According to Lund (1996) the energy demand for one kg Cemskum® is 220 g oil, which at an energy content of 42 MJ kg<sup>-1</sup> is equivalent to 9.24 MJ kg<sup>-1</sup> (at a density of Cemskum of 0.23: 2125 MJ m<sup>-3</sup>).

<sup>31</sup> Production of Al-hydroxide, etc. takes another 32 MJm<sup>-3</sup>.

<sup>32</sup> We use the 50 km from the ExtemE investigation (EC, 1995/3, 90) for cement transport and 200 km for the binder transport.

being insulators, conduct heat energy from the inside to the outside, of the products differs. EPS and Glasuld need to be applied thicker than *e.g.* Paperwool, Perlite or Rockwool. Taking this into consideration increases the amount needed, and the relevant emissions from the production and transport: of EPS by 20 per cent, of Glasuld by 38 per cent and of Cemskum by 85 per cent. This is given Table A.82 in the row called *corrected mass*.

We apply this value in the following LCA. Still we note Cemskum is special in that it can be bearing element and so will not be applied as an extra building part as all the other insulation materials will be. Therefore its inclusion in this table might be misleading. Rockwool needs to be 2.5 per cent thinner due to its lower thermal conductivity.

Table A.83 gives an overview of the air emissions of SO<sub>2</sub>, NO<sub>x</sub>, particles and some acids, for a production of an equivalent of 1000 m<sup>3</sup> Paperwool<sup>33</sup> with an energy system of the future that is equivalent to the fair market scenario (for a definition of this see the following sections). All those calculations are inclusive the transport of the final products to the final consumer<sup>34</sup>. It can be seen that the production and use of Paperwool is the material that will contribute least to the emissions of SO<sub>2</sub>, NO<sub>x</sub> and particles, while Perlite is the topscorer in that respect, although this is caused by the ship transport of the raw material to Denmark. In the calculations it was assumed that this still will be going on with bunker<sup>35</sup> fuelled ships. The two mineral fibre products are only slightly more polluting than Paperwool, and EPS also leads to rather large emissions, also in this case caused by the ship transport of the raw material to the production sites.

**Table A.83 Total air emissions**

Material	SO <sub>2</sub>	NO <sub>x</sub>	Particles	HCl	HF
Pollutant [kg per 1000 equivalent m <sup>3</sup> ]					
Paperwool	2.28	22.77	4.05	0.002	0.000
Perlite	143.17	189.08	85.08	0.004	0.000
EPS	56.98	27.82	1.63	0.012	0.001
Glasuld	7.03	19.20	30.39	0.007	0.001
Rockwool	4.55	13.85	32.58	0.005	0.001
Cemskum	96.84	1088.96	533.13	0.029	0.003

Cemskum is also leading to large emissions, this is caused by the large sulphur load of biogas which is assumed to be used in the manufacturing process of cement, the basic ingredient of Cemskum. The large emissions of NO<sub>x</sub> come from the cement production and the particles from the raw materials for cement.

If there will be installed desulphurisation of the fuel in some centralised biogas plants, then the SO<sub>2</sub> emissions will go down for that material, but also for other materials where biogas fuelled furnaces will provide industrial process heat. Cemskum is probably not so bad in that respect, when we consider that it might be applied to insulate heat pipes in industry and power stations, where a mineral wool would lead to a large amount of hazardous wastes over the years.

Table A.84 shows the respective emissions of CO<sub>2</sub> and other gases with a global warming potential (GWP) from the production of the six insulation materials. The last column contains an recalculation of the equivalent GWP in CO<sub>2</sub> amounts using data from IPCC (1996) for most of the gases and GEMIS (1992) for NMVOC<sup>36</sup>.

<sup>33</sup> *I.e.* as corrected for the respective thermal conductivity.

<sup>34</sup> This is taken to be 200 km for all the products except for Cemskum, where the cement transport is only 50 km. This value is given in EC 1995/3,

<sup>35</sup> Bunker oil has a sulphur content of 3 %.

<sup>36</sup> Non-methane organic compounds.

We can see that Perlite and EPS here lead to rather large emissions for the standard insulation products. For Perlite this is caused by the long transport ship of the raw material to Denmark and that the final product still has a rather high density. For EPS the reason is that this product still will be made of crude oil, where both the transport and the production process will liberate fossil CO<sub>2</sub>. If in the future biogenic fuels will be used in international maritime transport, too, then those emissions will be much smaller.

**Table A.84 Greenhouse Gas Emissions (CO<sub>2</sub>-Equiv. include userdef. emissions)**

Species	CO <sub>2</sub>	CO	CH <sub>4</sub>	NMVOC	N <sub>2</sub> O	CO <sub>2</sub> -Equiv.
	Emissions [kg per 1000 equivalent m <sup>3</sup> ]					
Paperwool	1874	10.1	1.3	6.5	3.0	3300
Perlite	9432	18.0	2.2	9.7	4.3	12686
EPS	8244	24.3	23.6	440.1	0.9	14352
Glasuld	3502	15.0	1.6	22.4	2.8	5032
Rockwool	2007	13.3	1.2	141.6	3.3	4960
Cemskum	264400	208.5	58.8	81.3	16.6	283700

Paperwool is giving the lowest total emissions, while the two mineral wool products are only slightly worse compared to the other products. But we have to remind the reader that these values are given for an energy system, where biogas, that does not lead to net CO<sub>2</sub> emissions<sup>37</sup>, is being used for process heat provisions. For Cemskum the high emissions of CO<sub>2</sub> are due to the cement production itself, and that the additive for the foaming process is assumed to be made of oil products, where both the production of this substance and its transport is performed by crude oil, respectively fossil fuels.

In aggregated form Table A.85 shows the total primary energy consumption for the six insulation materials and the demand for raw materials (*primary materials*) and recycled materials (*secondary materials*). The first will still have to be extracted from mines, while the second will simply have to be collected and reused. The latter is not without problems as discussed in the metals section. The primary energy demand shown here is the total energy that has to be extracted, e.g. via wind mills or from oil wells, to be needed in the production of the 1000 equivalent m<sup>3</sup> of insulation material for each species. The primary materials only cover proper materials and not resumes, like heaps from mineral excavation.

**Table A.85 Resources used for six insulation materials**

Material	Primary energy[MJ]	Primary materials[kg]	Secondary materials[kg]
Paperwool	113700	32828	50
Perlite	458900	84727	194
EPS	1568000	41175	602
Glasuld	1003000	35045	443
Rockwool	653500	35239	308
Cemskum	5293000	708000	1487

As could have been estimated from the emissions data Cemskum, EPS and Glasuld show a high primary energy demand, while Paperwool is the one with the least primary energy demand. This could have importance for the future energy systems, when a recycled material like Paperwool will mean much reduced externalities from the energy provision for the production of insulation materials. Due to the special construction of the GEMIS program we have to mention separately

<sup>37</sup> It is assumed that the carbon will circulate in a closed circle between the biomass production, where it is absorbed by the plants, the biogas plant where the biomass will be converted to biogas, possibly over the step of animal manure, and the industrial furnace where the carbon content of the biogas will be released as CO<sub>2</sub> again that will be absorbed by the plants. Any other emissions, e.g. of N<sub>2</sub>O, are however taken into consideration.



that for the production of 10,000 m<sup>3</sup> Paperwool an amount of 25 tons of old newspapers has to be collected.

The high primary energy demand of Cemskum naturally is due to the cement production, which is the raw material of the product, and this process can maybe not changed much in the future. Also this product necessitates a high demand of primary materials, for the same reason as for the energy demand.

#### *Insulation Material Externality Adders*

From the analysis above we can calculate the externality adders of the insulation material use (Table A.86), where we use the damage factors given in the data section of the main text.

**Table A.86 Externality adders for six insulation materials**

Material	SO <sub>2</sub>	NO <sub>x</sub>	Partic.	CO <sub>2</sub> -Equiv.
Paperwool	0.19	2.59	0.55	16.85
Perlite	4.10	7.52	4.06	22.68
EPS	5.22	3.54	0.25	82.09
Glasuld	0.65	2.47	4.69	29.08
Rockwool	0.36	1.51	4.25	24.25
Cemskum	0.52	8.14	4.79	95.34
damage in ECU/kg	2.29	3.18	3.82	0.14

Data given in damages in ECU per ton of material produced.

It has to be noted that we in Table A.86 have given the data in damage costs from externalities from the production of the insulation materials per mass unit, *i.e.* in ECU per ton.

#### *Insulation Materials Synopsis*

Here we would like to give a short synopsis of the LCA of insulation materials that we have given above.

The question of the work environment still has to be analysed for all the products. Especially with respect to a monetarisation of the work environment related impacts.

It seems that Paperwool is a very good alternative to the established insulation materials from an energy point of view. Perlite and EPS might still be an alternative, but the latter material is dependent on crude oil supplies, but currently only about 0.15 per mill of the total crude oil consumption is used for EPS production (BAT, 1996, 53), so that a rather small supply would suffice for this. Perlite is not inflammable and so can be used for constructions, where this aspect is important.

Glasuld could still used, if it can be shown that it has indispensable features for certain applications that will justify its application there. Its rather high content of binders could pose environmental problems, this is also valid for Rockwool. Some mineral wool products have the advantage of fire stability, and therefore will probably be used where this feature is important. If we assume that security regulations as a consequence of the convergence trend in the European Union will become more alike, then it is perceivable that Paperwool, due to its favourable energy balance, will offer a substitution of mineral wool products to a certain degree. In any case BAT (1996) gives many proposals for applications where alternative products can substitute mineral wool products.

Cemskum looks to become of importance in technical insulation. It might be possible to create new building components with "built-in" insulation with this material. However, it has to be ensured that any Sandwich construction does not lead to products that cannot be re-used or the basic substances that can not be recuperated. In that respect Cemskum might become one answer

to other technologies that offer technical advantages from double uses, as PV panels that can be used as facade elements.

**Tables over emissions from various processes, using TEMIS acronyms for technical ref.**

*Table over CO<sub>2</sub> emissions from Biogas year 2050*

Mat-pro\fertilizer-N	100.968
Mat-pro\chalk	63.305
Mat-pro\fertilizer-K	38.028
propane-boiler-ind	29.394
Tanker\OPEC-oilPC	29.162
Coke-converter	28.388
cement	24.335
oil-H-boiler-ind-G	24.259
Hydro-PP-ExtemE	14.745
Mat-pro\alu	7.159
Compressor-GT-G	5.114
ship-ocean-gen	3.597
Hydro-PP-MX	3.187
hcoal-PP-ST-Oz/US	1.534
gas-PP-GT-NOR	1.39
bulk-ocean	1.296
glass	0.501
Mat-pro\sinter	0.214
Mat-pro\mineral-wool	0.007

*Table over particles emissions from Biogas year 2050*

Zero-proc-ind-DK	0.72
Xtra-gen\stone&clay	0.238
Dieselmotor-rape	0.057
Mat-pro\alu	0.02
biogas-furnace	0.011
bio-BPS-pr-lean	0.008
bio-BPS-pr-cat	0.006
Tanker\OPEC-oilPC	0.005
fuel-cell-2030	0.004
biogas-furnace-ind	0.001
Coke-converter	0.001
biowaste-BPS-pr	0.001
hcoal-PP-ST-Oz/US	0.001
Compressor-GT-G	0
propane-boiler-ind	0
gas-PP-GT-NOR	0
bulk-ocean	0
ship-ocean-gen	0

*Table over SO<sub>2</sub> and NO<sub>x</sub> emissions from Biogas Today*

Zero-pro-DK	212.4	49.56
truck-freight-gen	25.147	302.746
Ship-ocean-gen	5.707	0
Dieselmotor-OPEC	4.053	4.459
oil-H-boiler-in-CIS	1.949	0.318
oil-H-boiler-ind-G	1.336	0.312

Coke-converter	0.692	1.701
oil-H-boiler-ind-gen	0.458	0.067
oil-H-boiler-ind-OPE	0.4	0.065
dieselmotor-CIS	0.283	0.363
Mat-pro\alu	0.149	0.013
hcoal-PP-ST-CIS	0.141	0.064
oil-H-PP-ST-CIS	0.075	0.012
oilgas-boiler-ind-G	0.064	0.11
Dieselmotor-generic	0.062	0.062
hcoal-PP-ST-ballast	0.056	0.033
oil-H-PP-ST-G	0.027	0.027
hcoal-PP-ST-G-mix	0.021	0.021
lign-PP-ST	0.016	0.029
lastbil-diesel	0.015	
hcoal-boiler-FBC-ind	0.007	0.008
gas-boiler-ind-G	0.006	0.628
bulk\diesel-DKPC	0.004	0.001
Zero-pro-ind-DK	0.001	0
bulk-ocean	0.001	
hcoal-PP-ST-Poland	0.001	0.001
Barge-freight-gen	0.001	0
Barge\crude-DKPC	0.001	0
waste-PP-ST	0.001	0.004
Dieselmotor-G	0	0.006
gas-GT-NOR	0	0.129
gas-PP-ST-G	0	0.017
Compressor-GT-DK	0	0.072
gas-PP-ST-CIS	0	0.018
Compressor-GT-CIS	0	0.057
hcoal-PP-ST-Oz/US	0	0
gas-boiler-ind-CIS	0	0.004
Compressor-GT-NOR	0	0.01
gas-GT-CIS	0	0.009
Compressor-GT-G	0	0.005
gas-PP-CC-NL	0	0.002
Compressor-GT-NL	0	0.003
gas-boiler-ind-NOR	0	0
gas-boiler-ind-NL	0	0
propane-boiler-ind	0.24	
cement	0.19	

*Table over particles emissions from Biogas Today*

truck-freight-gen	20.183
Zero-pro-DK	6.24
Dieselmotor-OPEC	0.372
Xtra-gen\stone&clay	0.149
oil-H-boiler-in-CIS	0.095

Mat-pro\alu	0.086	oil-H-boiler-ind-G	5.579
dieselmotor-CIS	0.052	gas-PP-GT-NOR	3.674
oil-H-boiler-ind-G	0.039	bulk-ocean	1.132
Coke-converter	0.034	Mat-pro\sinter	0.651
hcoal-PP-ST-CIS	0.032	hcoal-PP-ST-Oz/US	0.557
oil-H-boiler-ind-gen	0.02	glass	0.555
oil-H-boiler-ind-OPE	0.02	Mat-pro\alu	0.206
Dieselmotor-generic	0.005	Mat-pro\mineral-wool	0.008
oil-H-PP-ST-G	0.004		
hcoal-PP-ST-ballast	0.004	<i>Table over SO<sub>2</sub> emissions from Methanol 2050</i>	
oil-H-PP-ST-CIS	0.004	woodchips-pro-ind-DK	218.796
lign-PP-ST	0.003	Source\biomass-DKPC	3.858
hcoal-PP-ST-G-mix	0.002	Mat-pro\fertilizer-N	1.029
gas-boiler-ind-G	0.002	biogas-fumace-ind	0.603
hcoal-boiler-FBC-ind	0.001	bio-BPS-pr-lean	0.169
Compressor-GT-DK	0.001	ship-ocean-gen	0.137
Compressor-GT-CIS	0.001	bio-BPS-pr-cat	0.116
propane-boiler-ind	0.001	Tanker\OPEC-oilPC	0.107
gas-PP-ST-CIS	0.001	Coke-converter	0.067
Dieselmotor-G	0.001	Dieselmotor-DK	0.053
gas-PP-ST-G	0	oil-H-boiler-ind-G	0.035
gas-GT-NOR	0	Mat-pro\fertilizer-K	0.031
hcoal-PP-ST-Poland	0	bulk-ocean	0.022
oilgas-boiler-ind-G	0	biowaste-BPS-pr	0.017
waste-PP-ST	0	biogas-fumace	0.013
Compressor-GT-NOR	0	truck-freight-Elsbet	0.003
bulk\diesel-DKPC	0	Dieselmotor-rape	0.002
gas-GT-CIS	0	hcoal-PP-ST-Oz/US	0.002
Compressor-GT-G	0	Mat-pro\alu	0.001
gas-boiler-ind-CIS	0	fuel-cell-2030	0.001
Compressor-GT-NL	0	truck-freight-gen	0
Zero-pro-ind-DK	0	Compressor-GT-G	0
Barge\crude-DKPC	0	gas-PP-GT-NOR	0
gas-PP-CC-NL	0	biogas-DH-boiler	-0.004
hcoal-PP-ST-Oz/US	0		
Ship-ocean-gen	0	<i>Table over particles emissions from Methanol 2050</i>	
gas-boiler-ind-NOR	0	woodchips-pro-ind-DK	4.199
gas-boiler-ind-NL	0	Source\biomass-DKPC	0.162
Barge-freight-gen	0	Xtra-gen\stone&clay	0.152
		Dieselmotor-rape	0.035
<i>Table over CO<sub>2</sub> emissions from Methanol 2050</i>		bio-BPS-pr-lean	0.023
Source\biomass-DKPC	813.863	bio-BPS-pr-cat	0.016
Mat-pro\fertilizer-N	262.864	biogas-fumace	0.014
Coke-converter	86.49	fuel-cell-2030	0.005
cement	51.837	biogas-fumace-ind	0.004
Hydro-PP-ExternE	39.486	Coke-converter	0.003
Mat-pro\chalk	16.052	biowaste-BPS-pr	0.002
Compressor-GT-G	13.517	Tanker\OPEC-oilPC	0.001
Hydro-PP-MX	8.107	Compressor-GT-G	0.001
Mat-pro\fertilizer-K	8.046	Mat-pro\alu	0.001
ship-ocean-gen	7.223	hcoal-PP-ST-Oz/US	0
propane-boiler-ind	6.759	gas-PP-GT-NOR	0
Tanker\OPEC-oilPC	6.53	propane-boiler-ind	0

ship-ocean-gen	0	Dieselmotor-generic	1.057		
bulk-ocean	0	waste-PP-ST	0.824		
<i>Table over CO<sub>2</sub> emissions from Methanol Today</i>					
Dieselmotor-DK	83527.94	hcoal-PP-ST-Poland	0.711		
KV-coal	6723.019	Barge-freight-gen	0.54		
bulk\diesel-DKPC	4462.114	Dieselmotor-G	0.528		
lastbil-diesel	4073.208	bulk-ocean	0.208		
gas-boiler-ind-G	3574.887	hydro-PP-MX	0.045		
Mat-pro\fertilizer-N	1584.266	hcoal-PP-ST-Oz/US	0.042		
Bulk\coal-imp-AUS/PC	1186.656	Mat-pro\mineral-wool	0.002		
Zero-pro-ind-DK	1147.611	glass	0.002		
oil-H-boiler-ind-G	829.253	Xtra-gen\stone&clay	0.343		
Coke-converter	630.548	woodchips-pro-in-DK	4.113		
Barge\crude-DKPC	480.129	fyr-straw	-0.035		
KV-oil	353.642	fyr-oil	-78.693		
hcoal-boiler-FBC-ind	236.625	fyr-coal	-226.31		
Dieselmotor-OPEC	216.631	fyr-waste	-241.183		
KV-NG	191.43	fyr-NG	-406.909		
KV-biomass-waste	164.103	Note: negative emissions signify heat substitution from cogeneration.			
cement	149.467	<i>Table over SO<sub>2</sub> and NO<sub>x</sub> emissions from Methanol today</i>			
gas-GT-NOR	100.943	Dieselmotor-DK	89.513	1087.794	
Compressor-GT-CIS	75.012	woodchips-pro-in-DK	63.402	41.13	
hcoal-PP-ST-G-mix	64.259	bulk\diesel-DKPC	25.04	6.426	
Ship-ocean-gen	53.739	Zero-pro-ind-DK	7.255	1.693	
lign-PP-ST	48.372	Mat-pro\fertilizer-N	6.199	229.604	
hcoal-PP-ST-ballast	45.532	KV-coal	5.957	4.745	
Mat-pro\alu	29.284	oil-H-boiler-ind-G	5.168	1.207	
oil-H-PP-ST-G	27.577	lastbil-diesel	4.365		
Compressor-GT-DK	27.253	Barge\crude-DKPC	4.324	1.605	
Hydro-PP-Externe	26.649	Bulk\coal-imp-AUS/PC	2.823	3.177	
Mat-pro\chalk	21.353	Dieselmotor-OPEC	2.444	2.689	
propane-boiler-ind	20.451	Ship-ocean-gen	1.022	0	
gas-PP-ST-G	18.747	Coke-converter	0.49	1.206	
gas-boiler-ind-CIS	17.042	KV-biomass-waste	0.233	0.156	
Compressor-GT-NOR	15.241	hcoal-boiler-FBC-ind	0.233	0.288	
gas-GT-CIS	11.212	Mat-pro\alu	0.141	0.012	
hcoal-PP-ST-CIS	7.76	oil-H-boiler-ind-gen	0.082	0.012	
Compressor-GT-G	7.462	oil-H-boiler-in-CIS	0.081	0.013	
oil-H-boiler-in-CIS	7.211	hcoal-PP-ST-CIS	0.06	0.028	
oil-H-boiler-ind-gen	6.537	hcoal-PP-ST-ballast	0.051	0.03	
Mat-pro\sinter	5.56	oil-H-boiler-ind-OPE	0.049	0.008	
gas-PP-CC-NL	5.504	KV-biogas	0.047		
gas-PP-ST-CIS	5.078	KV-oil	0.036	0.614	
oilgas-boiler-ind-G	4.513	oil-H-PP-ST-CIS	0.032	0.005	
oil-H-boiler-ind-OPE	4.365	oil-H-PP-ST-G	0.031	0.03	
Compressor-GT-NL	4.328	gas-boiler-ind-G	0.028	2.721	
Zero-pro-DK	3.523	hcoal-PP-ST-G-mix	0.024	0.024	
oil-H-PP-ST-CIS	2.83	Zero-pro-DK	0.022	0.005	
gas-boiler-ind-NOR	2.614	lign-PP-ST	0.018	0.034	
truck-freight-gen	2.543	Dieselmotor-generic	0.013	0.013	
gas-boiler-ind-NL	1.619	dieselmotor-CIS	0.012	0.016	
dieselmotor-CIS	1.086	bulk-ocean	0.004		

hcoal-PP-ST-Poland	0.004	0.004 lign-PP-ST	0.003
Barge-freight-gen	0.003	0 hcoal-PP-ST-ballast	0.003
truck-freight-gen	0.003	0.033 Mat-pro\alu	0.081
oilgas-boiler-ind-G	0.002	0.004 oil-H-PP-ST-G	0.005
KV-NG	0.001	0.187 Compressor-GT-DK	0.002
gas-GT-NOR	0.001	0.295 Hydro-PP-ExternE	
waste-PP-ST	0.001	0.004 Mat-pro\chalk	
Dieselmotor-G	0.001	0.007 propane-boiler-ind	0
Compressor-GT-CIS	0.001	0.453 gas-PP-ST-G	0
Compressor-GT-DK	0	0.139 gas-boiler-ind-CIS	0
hcoal-PP-ST-Oz/US	0	0 Compressor-GT-NOR	0.001
gas-PP-ST-G	0	0.019 gas-GT-CIS	0.001
gas-boiler-ind-CIS	0	0.034 hcoal-PP-ST-CIS	0.014
Compressor-GT-NOR	0	0.078 Compressor-GT-G	0.001
gas-GT-CIS	0	0.068 oil-H-boiler-in-CIS	0.004
Compressor-GT-G	0	0.04 oil-H-boiler-ind-gen	0.004
gas-PP-CC-NL	0	0.017 Mat-pro\sinter	
gas-PP-ST-CIS	0	0.008 gas-PP-CC-NL	0
Compressor-GT-NL	0	0.023 gas-PP-ST-CIS	0
gas-boiler-ind-NOR	0	0.002 oilgas-boiler-ind-G	0
gas-boiler-ind-NL	0	0.001 oil-H-boiler-ind-OPE	0.002
propane-boiler-ind	0.018	Compressor-GT-NL	0
Mat-pro\mineral-wool	0	Zero-pro-DK	0.001
glass	0	oil-H-PP-ST-CIS	0.002
cement	0.598	gas-boiler-ind-NOR	0
fyr-NG	-0.003	-0.198 truck-freight-gen	0.002
fyr-oil	-0.079	-0.032 gas-boiler-ind-NL	0
fyr-straw	-0.126	-0.094 dieselmotor-CIS	0.002
fyr-waste	-0.172	-1.207 Dieselmotor-generic	0.001
fyr-coal	-1.543	waste-PP-ST	0
		hcoal-PP-ST-Poland	0.001
<i>Table over particles emissions from Methanol today</i>		Barge-freight-gen	0
Dieselmotor-DK	90.65	Dieselmotor-G	0.001
KV-coal	1.318	bulk-ocean	
bulk\diesel-DKPC	0.767	hydro-PP-MX	
lastbil-diesel		hcoal-PP-ST-Oz/US	0
gas-boiler-ind-G	0.009	Mat-pro\mineral-wool	
Mat-pro\fertilizer-N		glass	
Bulk\coal-imp-AUS/PC	0.687	Xtra-gen\stone&clay	
Zero-pro-ind-DK	0.213	woodchips-pro-in-DK	
oil-H-boiler-ind-G	0.151	fyr-straw	
Coke-converter	0.024	fyr-oil	
Barge\crude-DKPC	0.16	fyr-coal	
KV-oil	0.205	fyr-waste	-0.069
hcoal-boiler-FBC-ind	0.048	fyr-NG	-0.001
Dieselmotor-OPEC	0.224		
KV-NG	0.005	<i>Table over CO2 emissions from PV Today</i>	
KV-biomass-waste	0.195	hcoal-PP-ST-G-mix	75092.52
cement		lign-PP-ST	56527.84
gas-GT-NOR	0.001	oil-H-PP-ST-G	32226.4
Compressor-GT-CIS	0.006	gas-PP-ST-G	21908.15
hcoal-PP-ST-G-mix	0.002	gas-boiler-ind-G	17000.13
Ship-ocean-gen	0	oil-H-boiler-ind-G	15120.08

Dieselmotor-G	11493.23	oil-H-boiler-ind-G	2.751
hcoal-boiler-FBC-ind	3867.898	Dieselmotor-G	12.473
Coke-converter	3475.994	hcoal-boiler-FBC-ind	0.785
hcoal-PP-ST-ballast	3394.786	Coke-converter	0.133
Dieselmotor-OPEC	3317.513	hcoal-PP-ST-ballast	0.25
Mat-pro\chalk	2170.832	Dieselmotor-OPEC	3.431
cement	1927.067	Mat-pro\chalk	
Mat-pro\alu	1632.282	cement	
Ship-ocean-gen	1558.764	Mat-pro\alu	4.542
glass	1353.333	Ship-ocean-gen	0
propane-boiler-ind	1352.848	glass	
waste-PP-ST	963.191	propane-boiler-ind	0.003
oil-H-boiler-in-CIS	489.373	waste-PP-ST	0.275
Compressor-GT-CIS	444.749	oil-H-boiler-in-CIS	0.27
Hydro-PP-ExternE	337.02	Compressor-GT-CIS	0.034
oilgas-boiler-ind-G	325.991	Hydro-PP-ExternE	
gas-GT-NOR	200.879	oilgas-boiler-ind-G	0.001
oil-H-boiler-ind-gen	195.194	gas-GT-NOR	0.001
hcoal-PP-ST-Poland	186.742	oil-H-boiler-ind-gen	0.108
hcoal-PP-ST-CIS	165.86	hcoal-PP-ST-Poland	0.353
Barge-freight-gen	141.637	hcoal-PP-ST-CIS	0.296
oil-H-boiler-ind-OPE	132.497	Barge-freight-gen	0
gas-boiler-ind-CIS	101.608	oil-H-boiler-ind-OPE	0.073
gas-PP-ST-CIS	100.534	gas-boiler-ind-CIS	0.003
Compressor-GT-NOR	89.701	gas-PP-ST-CIS	0.005
dieselmotor-CIS	84.169	Compressor-GT-NOR	0.007
gas-GT-CIS	66.821	dieselmotor-CIS	0.174
oil-H-PP-ST-CIS	56.016	gas-GT-CIS	0.005
bulk-ocean	54.584	oil-H-PP-ST-CIS	0.031
lastbil-diesel	53.922	bulk-ocean	
lastbil-diesel	53.922	lastbil-diesel	
Compressor-GT-G	44.24	lastbil-diesel	
truck-freight-gen	42.152	Compressor-GT-G	0.003
Compressor-GT-DK	39.076	truck-freight-gen	0.036
Dieselmotor-generic	35.738	Compressor-GT-DK	0.003
gas-PP-CC-NL	32.629	Dieselmotor-generic	0.037
Mat-pro\sinter	26.154	gas-PP-CC-NL	0
Compressor-GT-NL	25.658	Mat-pro\sinter	
gas-boiler-ind-NOR	14.919	Compressor-GT-NL	0.002
hcoal-PP-ST-Oz/US	11.162	gas-boiler-ind-NOR	0
gas-boiler-ind-NL	9.597	hcoal-PP-ST-Oz/US	0.004
bulk\diesel-DKPC	2.738	gas-boiler-ind-NL	0
Zero-pro-ind-DK	0.707	bulk\diesel-DKPC	0
hydro-PP-MX	0.399	Zero-pro-ind-DK	0
Barge\crude-DKPC	0.295	hydro-PP-MX	
Xtra-gen\stone&clay	18.207	Barge\crude-DKPC	0
		Xtra-gen\stone&clay	
<i>Table over particles emissions from PV Today</i>		<i>Table over CO<sub>2</sub> emissions from PV 2050</i>	
hcoal-PP-ST-G-mix	2.843	cement	645.542
lign-PP-ST	4.088	Mat-pro\chalk	629.511
oil-H-PP-ST-G	5.926	Mat-pro\alu	434.933
gas-PP-ST-G	0.556	glass	390.607
gas-boiler-ind-G	0.043		

Hydro-PP-ExternE	165.539	Compressor-GT-G	0.417
propane-boiler-ind	106.693	gas-PP-GT-NOR	0.113
Tanker\OPEC-oilPC	104.581	Mat-pro\alu	0.107
Mat-pro\fertilizer-N	95.295		
oil-H-boiler-ind-G	88.055	<i>Table over particles emissions from Wind 2050</i>	
Coke-converter	84.701	Xtra-gen\stone&clay	8.189
bulk-ocean	57.814	Dieselmotor-rape	0.096
Hydro-PP-MX	40.991	bio-BPS-pr-lean	0.023
Mat-pro\fertilizer-K	35.891	bio-BPS-pr-cat	0.016
ship-ocean-gen	11.432	Coke-converter	0.01
Compressor-GT-G	10.323	biogas-furnace-ind	0.004
gas-PP-GT-NOR	2.805	fuel-cell-2030	0.004
hcoal-PP-ST-Oz/US	1.615	biowaste-BPS-pr	0.002
Mat-pro\sinter	0.637	Tanker\OPEC-oilPC	0.001
Mat-pro\mineral-wool	0.534	biogas-furnace	0.001
		Mat-pro\alu	0
<i>Table over particles emissions from PV 2050</i>		hcoal-PP-ST-Oz/US	0
Xtra-gen\stone&clay	4.844	Compressor-GT-G	0
Dieselmotor-rape	3.582	propane-boiler-ind	0
Mat-pro\alu	1.21	gas-PP-GT-NOR	0
fuel-cell-2030	0.325	ship-ocean-gen	0
bio-BPS-pr-lean	0.152	bulk-ocean	0
bio-BPS-pr-cat	0.104		
biogas-furnace	0.097	<i>Table over CO<sub>2</sub> emissions from Wind Today</i>	
biogas-furnace-ind	0.018	Coke-converter	3683.845
Tanker\OPEC-oilPC	0.018	gas-boiler-ind-G	3121.777
biowaste-BPS-pr	0.015	cement	1347.236
Coke-converter	0.003	Dieselmotor-OPEC	1129.121
Compressor-GT-G	0.001	hcoal-PP-ST-ballast	204.064
hcoal-PP-ST-Oz/US	0.001	Ship-ocean-gen	200.196
propane-boiler-ind	0	hcoal-PP-ST-G-mix	151.429
gas-PP-GT-NOR	0	Mat-pro\chalk	124.437
bulk-ocean	0	oil-H-boiler-ind-G	119.626
ship-ocean-gen	0	lign-PP-ST	113.991
		oil-H-PP-ST-G	64.987
<i>Table over CO<sub>2</sub> emissions from Wind 2050</i>		lastbil-diesel	57.147
cement	4059.526	gas-PP-ST-G	44.179
Coke-converter	264.97	Compressor-GT-CIS	35.854
Hydro-PP-ExternE	119.554	Zero-pro-ind-DK	35.749
Hydro-PP-MX	26.264	Mat-pro\sinter	27.718
ship-ocean-gen	26.013	oil-H-boiler-ind-gen	24.269
Mat-pro\chalk	15.55	oil-H-boiler-ind-OPE	17.583
propane-boiler-ind	8.216	propane-boiler-ind	14.863
Tanker\OPEC-oilPC	7.474	hcoal-boiler-FBC-ind	13.132
oil-H-boiler-ind-G	6.781	Mat-pro\mineral-wool	12.5
glass	4.718	glass	12.5
Mat-pro\mineral-wool	4.273	gas-boiler-ind-CIS	8.147
bulk-ocean	3.397	gas-GT-NOR	7.971
Mat-pro\fertilizer-N	2.302	Compressor-GT-NOR	7.218
Mat-pro\sinter	1.994	gas-GT-CIS	5.359
Mat-pro\fertilizer-K	0.867	oil-H-boiler-in-CIS	5.09
hcoal-PP-ST-Oz/US	0.796	Dieselmotor-generic	4.881
		hcoal-PP-ST-CIS	3.9

Compressor-GT-G	3.567	Zero-pro-ind-DK	0.007
Hydro-PP-ExternE	3.343	Mat-pro\sinter	
oilgas-boiler-ind-G	3.277	oil-H-boiler-ind-gen	0.013
bulk\diesel-DKPC	2.902	oil-H-boiler-ind-OPE	0.01
gas-PP-CC-NL	2.631	propane-boiler-ind	0
gas-PP-ST-CIS	2.551	hcoal-boiler-FBC-ind	0.003
Compressor-GT-NL	2.069	Mat-pro\mineral-wool	
waste-PP-ST	1.942	glass	
oil-H-PP-ST-CIS	1.421	gas-boiler-ind-CIS	0
Dieselmotor-G	1.245	gas-GT-NOR	0
gas-boiler-ind-NOR	1.191	Compressor-GT-NOR	0.001
gas-boiler-ind-NL	0.774	gas-GT-CIS	0
dieselmotor-CIS	0.761	oil-H-boiler-in-CIS	0.003
Compressor-GT-DK	0.411	Dieselmotor-generic	0.005
hcoal-PP-ST-Poland	0.389	hcoal-PP-ST-CIS	0.007
Mat-pro\alu	0.367	Compressor-GT-G	0
Barge\crude-DKPC	0.312	Hydro-PP-ExternE	
Barge-freight-gen	0.295	oilgas-boiler-ind-G	0
hydro-PP-MX	0.26	bulk\diesel-DKPC	0
bulk-ocean	0.114	gas-PP-CC-NL	0
hcoal-PP-ST-Oz/US	0.023	gas-PP-ST-CIS	0
truck-freight-gen	0.005	Compressor-GT-NL	0
Xtra-gen\stone&clay	3.097	waste-PP-ST	0.001
		oil-H-PP-ST-CIS	0.001
<i>Table over particles emissions from Wind Today</i>		Dieselmotor-G	0.001
Coke-converter	0.141	gas-boiler-ind-NOR	0
gas-boiler-ind-G	0.008	gas-boiler-ind-NL	0
cement		dieselmotor-CIS	0.002
Dieselmotor-OPEC	1.168	Compressor-GT-DK	0
hcoal-PP-ST-ballast	0.015	hcoal-PP-ST-Poland	0.001
Ship-ocean-gen	0	Mat-pro\alu	0.001
hcoal-PP-ST-G-mix	0.006	Barge\crude-DKPC	0
Mat-pro\chalk		Barge-freight-gen	0
oil-H-boiler-ind-G	0.022	hydro-PP-MX	
lign-PP-ST	0.008	bulk-ocean	
oil-H-PP-ST-G	0.012	hcoal-PP-ST-Oz/US	0
lastbil-diesel		truck-freight-gen	0
gas-PP-ST-G	0.001	Xtra-gen\stone&clay	
Compressor-GT-CIS	0.003		



**Table of Contents**

Energy Transformation Chains .....	107
Analysis of different energy conversion processes .....	107
Technology lists .....	108
Conversion Technologies Descriptions .....	108
ST-fossil .....	109
Efficiencies of Used Technologies in Denmark Today .....	111
Occupational Health Impacts of the Utility Sector .....	113
boilers .....	114
furnace .....	117
residential .....	119
onshore .....	120
Occupational Health Impacts from Wind Turbine Construction and Maintenance .....	120
Visual Impacts .....	121
offshore .....	122
PV .....	123
HPs .....	127
SOFC .....	128
H2mot .....	129
hydropower .....	130
Tropical hydropower .....	131
DH&storage .....	131
Phase change heat storage .....	133
transmission .....	134
pipeline .....	135
Non-Electric Primary Energy Sources .....	137
Biomass production .....	137
bioplant .....	137
Elementary Analysis .....	137
Energy Input-Output Relations .....	137
Rotation and Installation .....	139
Occupational Impacts .....	139
Greenhouse Gas Emissions .....	141
Transportation of Biomass .....	141
Sugar Beet Data .....	142
biorest .....	143
Energy Input-Output Relations .....	143
Occupational and Transport Impacts .....	144
Environmental Impacts .....	144
biogas .....	144
Emissions to the Air .....	146
hydrogen .....	147
Occupational and Environmental Impacts from Hydrogen Technology .....	148

liquid.....	148
Fossil Fuels.....	149
Sustainability of Fossils ?.....	149
Greenhouse and Fossils.....	150
Fossil Dependence.....	150
Environmental Effects of Fossil Fuels.....	150
Overview of Fossil Fuels.....	151
Coal.....	151
Occupational Impacts.....	151
Transport Impacts.....	152
Environmental Impacts.....	153
Crude Oil.....	154
Occupational Impacts.....	154
Transport Impacts.....	155
Environmental Impacts.....	155
Petroleum Products.....	155
Occupational Impacts.....	155
Transport Impacts.....	155
Environmental Impacts.....	156
Natural Gas.....	156
Occupational Impacts.....	156
Environmental Impacts.....	156
Transport Impacts.....	157
Occupational Impacts of Fossils.....	157
Persons Transportation Technologies.....	158
petrCars.....	158
diesBuses.....	158
bioCars.....	159
bioBuses.....	159
localPT and regioPT preview.....	159
localPT.....	160
regioPT.....	160
plane.....	161
Goods Transport Technologies.....	161
petrVan.....	161
bioVan.....	162
diesLorry.....	162
bioLorry.....	163
ships.....	164
industry.....	164
ratio.....	164
Material Conversions.....	164
Electricity Supply System.....	165
Steel.....	165

---

Aluminium and Copper.....	167
Cement.....	168
Insulation Material.....	168
Information Limits.....	169
Why Insulation?.....	170
Presentation of Various Insulation Materials.....	171
Insulation Materials Energy Balances.....	173
Insulation Material Externality Adders.....	177
Insulation Materials Synopsis.....	177
Tables of emissions from various processes.....	178

## APPENDIX B:

### Efficiency of energy use for transportation of persons in Denmark - past trends and future possibilities.

This appendix gives an overview of the development in energy use for transport of persons in Denmark. Focus is primarily aimed at describing the historical development in the energy efficiency of the most important energy consuming modes for personal transportation in Denmark, namely cars, aircraft and trains, and the future possibilities to increase the energy efficiency of these transportation modes by developing more efficient technologies and new lightweight materials for the transportation modes. In this way we give input to the assumptions made in the two future scenarios.

#### Background.

Denmark has signed the United Nation's Climate Convention, which means that the Danish government aim at reducing the emissions of greenhouse gasses to the atmosphere in the future. This obligation is the keystone in the Danish government's latest energy plan released in 1996 "Energy 21"<sup>1</sup>. In this energy plan the Danish government has implemented the goal of achieving a 20% reduction in the emissions of carbon dioxide related to energy use before 2005 compared to 1990. Furthermore it is mentioned in the energy plan, that much greater reductions in the emissions of carbon dioxide will be needed in the future to avoid the possible danger of the enhanced greenhouse effect, the so called global warming. Beyond 2005 the government has not yet put up any specific goal for the necessary reduction in overall emissions of carbon dioxide, but it is mentioned that a 50% reduction might be needed before 2030, and the specific goal of a 25% reduction in the transport sector between 2005 and 2030 is mentioned, at the same time as it is accepted that the 2005 emissions from the transport sector will at best be at the level of 1988 (cf. ref.<sup>2</sup>), and that other sectors such as the power sector must reach a correspondingly higher reduction before 2005, in order to reach the overall 2005 goal. The demand for transport currently continues to grow as fast as during the last decades.

#### Transportation of persons in Denmark.

Domestic passenger transport, measured in person kilometres, grew by 30% in the period from 1984 to 1993. The growth in transport work was primarily generated by growth in transport by private cars. Private cars furthermore contributed to the main part of personal transportation measured in person kilometres. Domestic rail, bus and aircraft transport work has been stable in the period while personal transportation by car has grown rapidly.

Prognoses from the Danish ministry of transport indicates, that the domestic use of cars, aircraft and rail will grow in the future, while the use of buses will remain fairly constant and the use of ferries will fall as the new bridges across the Danish waters will be put into service. The prognoses from the Danish ministry of transport is based on the assumption of a low economic growth in the future and calculated by the economic model ADAM. The Danish ministry of transport forecast the use of cars to continue to grow until 2030 leading to a growth in car traffic of 62% between 1994 and 2030. Transport work by train is expected to

<sup>1</sup> Miljø- og energiministeriet, "Energi 21 - regeringens handlingsplan 1996".

<sup>2</sup> Trafikministeriet, "Regeringens handlingsplan for reduktion af transportsektorens CO<sub>2</sub>-udslip", 1996.

grow by 16% between 1994 and 2030 while domestic passenger traffic by aircraft is expected to almost double in the period<sup>3</sup>.

Figure B.1<sup>4</sup>: (note: only domestic transport!)

Domestic transport of persons in Denmark by modes

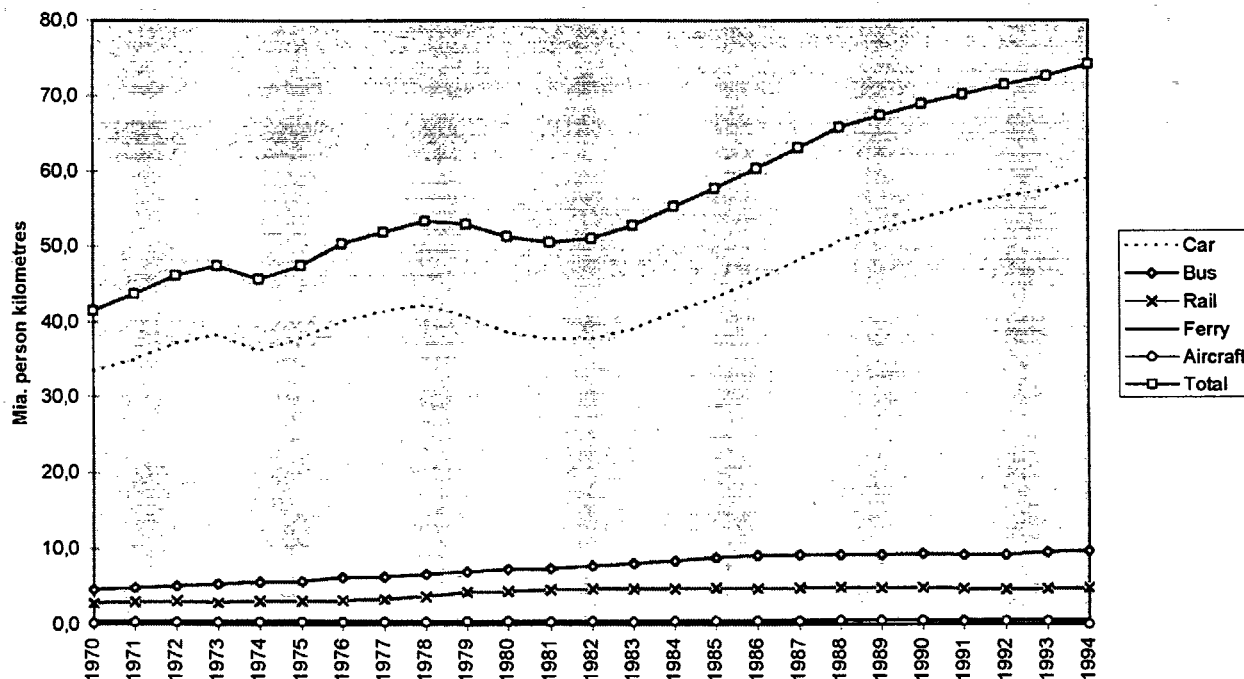

International aircraft traffic has grown in the last decades. The amount of passenger kilometres performed by aircraft in the EU has grown by 378% between 1970 and 1990<sup>5</sup>. If this trend continues in Denmark in the future the amount of passenger kilometres performed by aircraft is expected to grow by 3,5% per year. In this way the use of aircraft will represent a bigger share of the total Danish transportation work in the future than it does today.

If the prognoses from the Danish ministry of transport for the future development in passenger transport is realised the total volume of passenger travel will grow by almost 75% until 2030 compared to 1995. The expected development is illustrated in Figure B-2 below.

In passing, it may be interesting to mention, that the dips in demand 1974 and 1980-83 roughly indicate a price sensitivity of demand amounting to 10% or a 5 years delay in growth, for a doubling in price.

<sup>3</sup> Trafikministeriet, "Working paper: Calculations for prognoses of the future transport activity by modes up to the year 2030", delivered by Michael Soetmann from the Danish ministry of transport, 1996.

<sup>4</sup> Vejdirektoratet, "Vejtrafikken i tal og tekst", 1995.

<sup>5</sup> Kommissionen for de Europæiske Fællesskaber, "Meddelelse fra kommissionen - den fælles transportpolitik fremtidige udvikling - en omfattende fællesskabsstrategi for "bæredygtig mobilitet", KOM(92) 494 endelig udgave, 1992.

**Figure B-2<sup>6</sup>: (note: includes international transport)**

The expected development in transport of persons by mode i Denmark

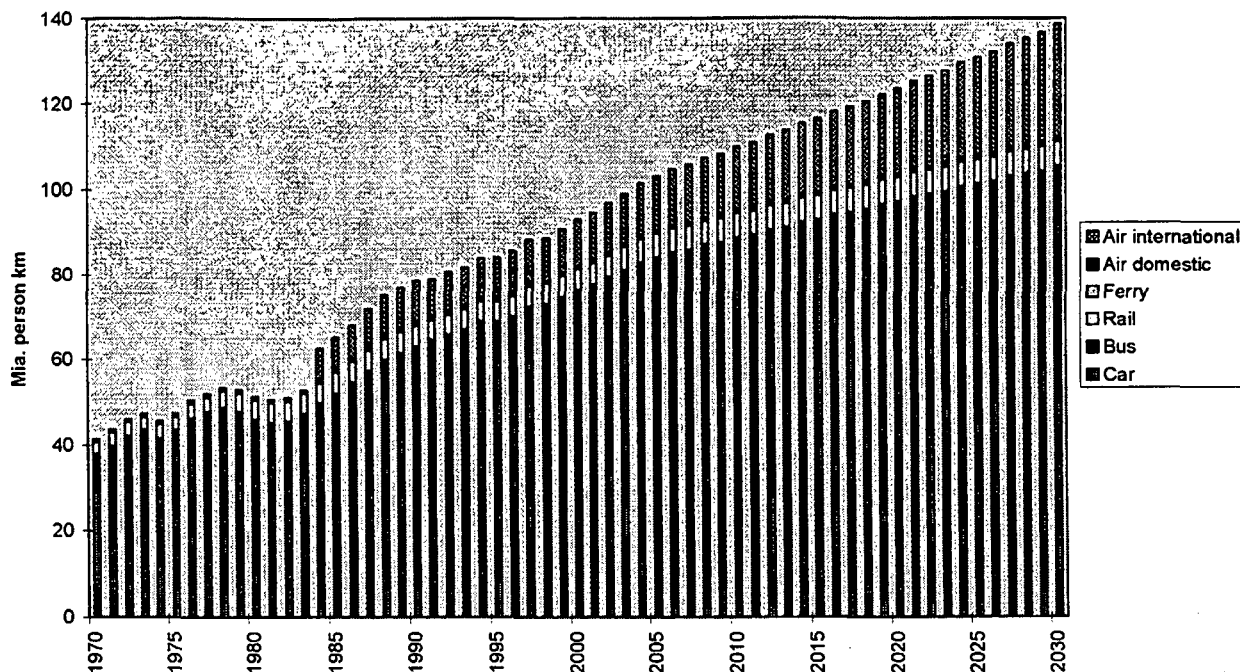

### Energy used for passenger transport in Denmark.

Energy use for the transport of persons has grown continuously through the last decades. In the period from 1984 to 1993 energy use for personal transportation grew by 12%. Cars are the main contributor to energy use for transportation of persons. Approximately 69% of the total energy use for personal transportation were used in cars in 1993 while 22% were used in aircraft. Busses and rail transport used 5% and 4% respectively<sup>7</sup>.

For international air traffic, past data are only shown for the period 1984-1994.

In light of the above mentioned prognoses for the expected future growth in transportation by private cars, aircraft and trains it must be expected that large improvements in transport technologies energy efficiency or use of less CO<sub>2</sub>-emitting fuels will be needed if the governments goals for reduction of the emissions of carbon dioxide is to be reached.

The scope of this appendix is to shed light on the possibilities to implement more energy efficient transport technologies in the future.

### Energy efficiency of persons transportation in Denmark - a historical overview.

<sup>6</sup> Historical data are taken from Vejdirektoratet, "Vejtrafikken i tal og tekst", 1995. The prognosis from 1994-2030 has been delivered by Michael Soetmann from the Danish ministry of transport, Trafikministeriet, "Working paper: Calculations for prognoses of the future transport activity by modes up to the year 2030", 1996.

<sup>7</sup> The energy use for personal transportation by modes is calculated on the basis of data from the Danish statistical office, RISØ and DSB: Danmarks statistik, "Transportstatistik 1995" and RISØ, "Computer programme to calculate emissions from road traffic 1993", af Niels A Kilde, Afdelingen for systemanalyse, RISØ, 1993 and DSB, "Ny fart i miljøet - DSB's miljøplan 1996".

The Danish car fleet's energy efficiency has been slightly improved since the early 1970'ties. A study performed by Lee Schipper indicates, that the average on the road specific fuel use of the Danish car fleet was around 9 litres per 100 kilometres in 1970 and around 8 litres per 100 kilometres in 1992<sup>8</sup>. In this period the car producers have somewhat improved the efficiency of car engines and drive systems and reduce cars rolling resistance and air drag. However, at the same time the average weight of cars has grown together with the average motor size. These developments has, together with other factors, led to a situation where the average on the road fuel economy of the Danish car fleet has only been slightly improved in the last 25 years. This situation is comparable to most other countries except the US, where the average fuel use has been improved drastically in the same period (but starting from an exceptionally poor performance).

Figure B-3<sup>9</sup>:

Energy use for transportation of persons in Denmark by mode.

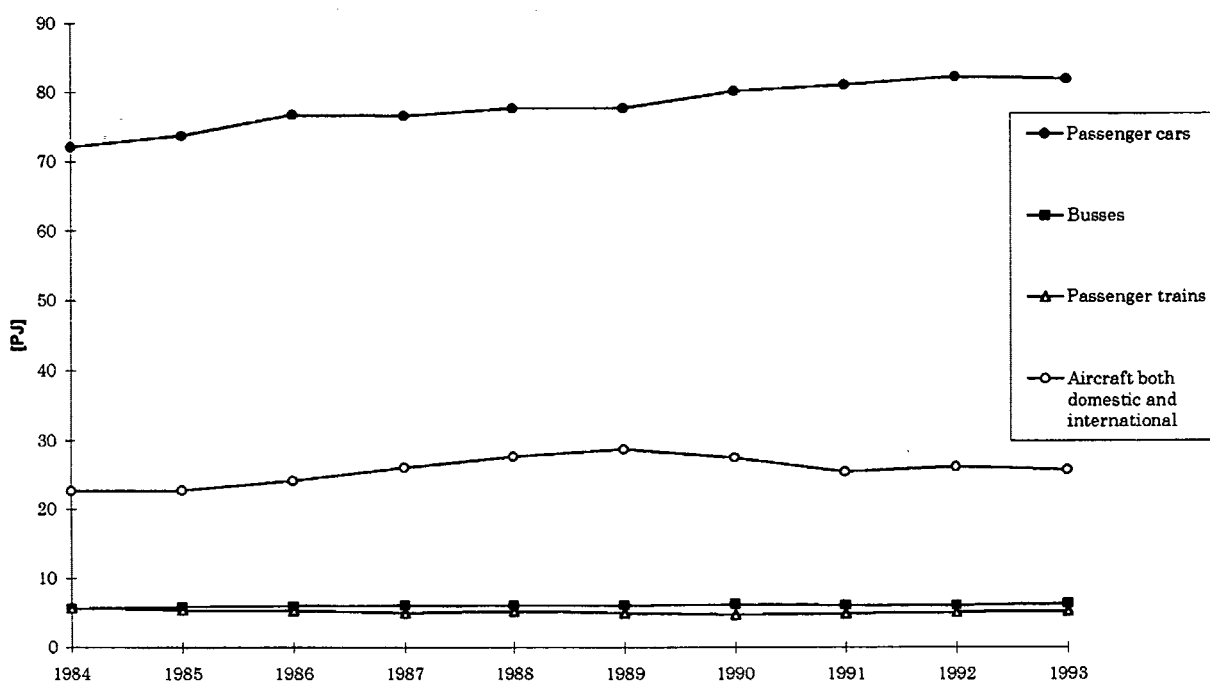

For the Danish aircraft fleet the development in specific fuel consumption has been much more positive. Scandinavian Airline Systems, SAS, estimate, that the company's aircraft fleet's specific fuel use per person kilometre has been reduced by more than 50% since the beginning of the 1970'ties<sup>10</sup>. This development is known from the global aircraft fleet, where the specific fuel use per passenger kilometre has been improved by more than 70% since the 1950'ties

<sup>8</sup> Schipper, Lee, "Determinants of automobile use and energy consumption in OECD countries", Annual review of energy and environment, 20:325-86, 1995.

<sup>9</sup> The energy use for personal transportation by modes is calculated on the basis of data from the Danish statistical office, RISØ and DSB: Danmarks statistik, "Transportstatistik 1995" and RISØ, "Computer programme to calculate emissions from road traffic 1993", af Niels A Kilde, Afdelingen for systemanalyse, RISØ, 1993 and DSB, "Ny fart i miljøet - DSB's miljøplan 1996".

<sup>10</sup> SAS, "Miljøregnskab 1995", 1996.

where the use of jets for civil transportation began. The reduction of fuel use per person kilometre has primarily been possible to obtain by the development of more efficient jet engines, increasing number of seats per aircraft, higher occupancy rates and reductions in aircraft weight per seat and air drag, but other factors has also had influence on the specific fuel use of aircraft<sup>11</sup>.

Figure B-4<sup>12</sup>:

Average on the road specific fuel use of the car fleet in selected countries including both diesel- and petrol cars

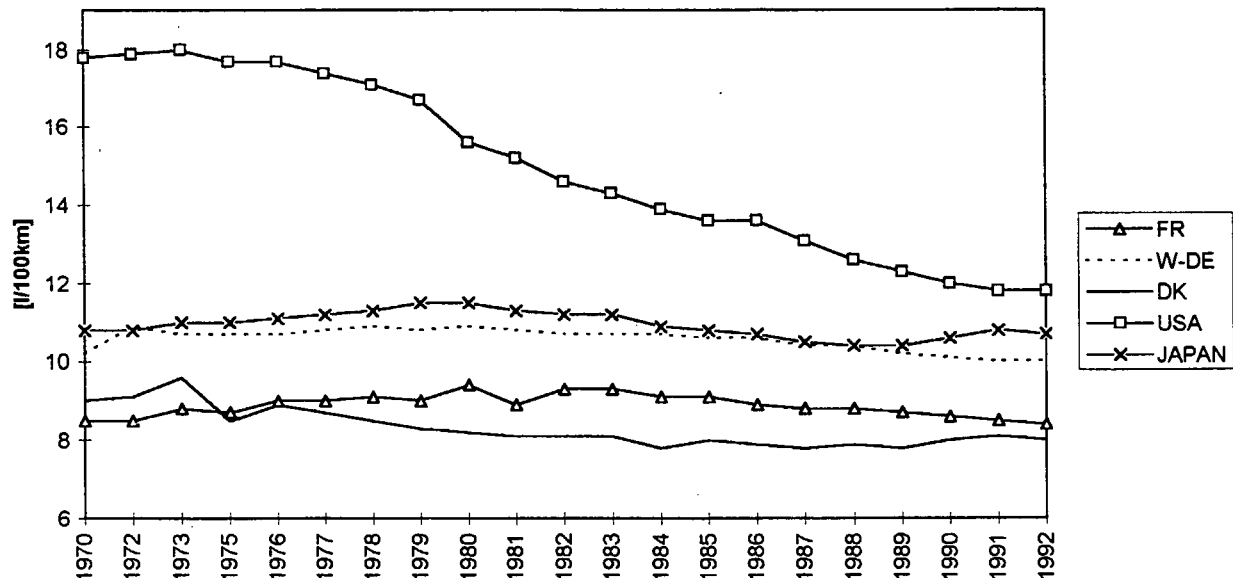

One example of a technology which has been improved is the jet engine technology. The specific fuel consumption of jet engines for civil aircraft has been reduced by approximately 50% since the first jet engines were installed in aircraft used for civil purposes. As can be seen in Figure 5, the specific consumption was reduced by approximately 30% when introducing the first low-bypass engines compared to the earliest turboprop engines. Later with the introduction of high bypass turbofan engines, the specific consumption was reduced by 30% compared to the low bypass models. The next generation of jet engines will probably be ultra high bypass turbo-fan engines or prop-fan engines which can probably reduce the specific consumption by another 30% compared to the best turbofan engines existing today.

The energy efficiency of the Danish train fleet has also been improved through the last decades. The energy efficiency of the train fleet has gradually been improved as new types of trains has been put into service. The main improvements in energy efficiency of trains has been achieved by lowering the weight per available seat in the trains. The use of aluminium for the trains body shell has been the key to reduce weight compared to the old steel bodies. Furthermore the lighter body shells has made it possible to use fewer and lighter bogies and wheels which are still made of steel. New design of the cabins and less spacing between the seats has made it

<sup>11</sup> ICAO Journal, "ICAO analyses trends in fuel consumption by world's airlines", By Boris Balashov and Andrew Smith from ICAO Air Transport Bureau, august 1992.

<sup>12</sup>Schipper, Lee, "Determinants of automobile use and energy consumption in OECD countries", Annual review of energy and environment, 20:325-86, 1995.



possible to put in more seats per length of the train. Finally some of the new electric trains are able to recover some of the braking energy which can not be recovered by the old diesel- and electrically powered trains.

**Figure B-5: Historic improvements in civil jet engines' specific fuel consumption and future possibilities<sup>13</sup>.**

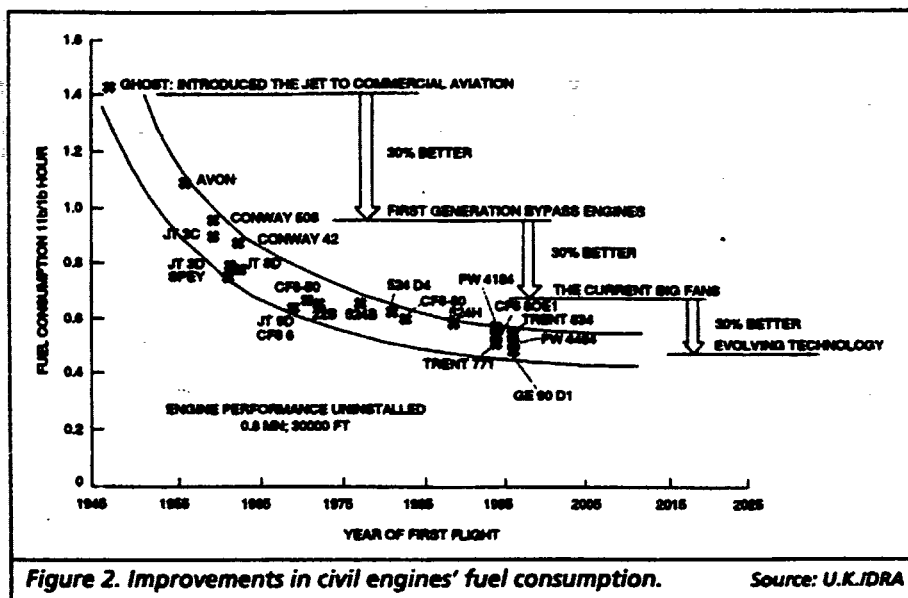

DSB, who takes care of around 80% of the total train transport in Denmark, has already made an option on the trains that are to replace the current fleet. As the train fleet consists of lots of different trains for different purposes it is not easy to estimate precisely how much more energy efficient the next generation of trains will be in general, but all the newest types of trains for domestic passenger transportation that is to replace the old ones are 23-48% more energy effective than the trains they replace<sup>14</sup>. The total train fleet is expected to be replaced around 2005.

In general it has been possible to improve the energy efficiency of the Danish aircraft- and train fleets in the last decades while the car fleet's specific on the road fuel use has only been slightly reduced. As cars are the main contributor to passenger transport and the related energy use and will probably also be so in the future too the major task in Denmark is to secure that more energy efficient cars are implemented if the Danish governments carbon dioxide reduction goal should be reached. However as aircraft transport is expected to grow even faster than car transport it also seems evident to secure that the historical development in aircraft energy efficiency continues in the future. As for train transport DSB has already invested in new trains which might possibly be in use the next 20-30 years before they are to be replaced. After this time it will be important to look at trains energy efficiency when designing the next generation of trains. Until that time it seems that the biggest potential to improve the train fleets energy efficiency is to use new lighter train types in areas of the country where the occupancy rate is

<sup>13</sup> Kilde: ICAO Journal, "Evolving noise issue could persist into the next century", M.J.T. Smith from Rolls Royce Company, august 1992.

<sup>14</sup> DSB, "Ny fart i miljøet - DSB's miljøplan 1996".

low. In these remote areas transportation by train is not more energy efficient than transport by cars or busses.

### Future scope of improving energy efficiency in cars, aircraft and trains in Denmark.

#### *How to promote today's most energy efficient car models.*

One of the main reasons why the Danish car fleet's average on the road fuel efficiency has not been improved much in the last decades is that the new cars sold on the market use almost as much energy per kilometre on average as it was the case with new cars in the early 1970'ties. This trend can be seen in Figure B-6.

**Figure B-6: Lee Schippers estimate of the specific on the road energy use of new cars in selected countries<sup>15</sup>.**

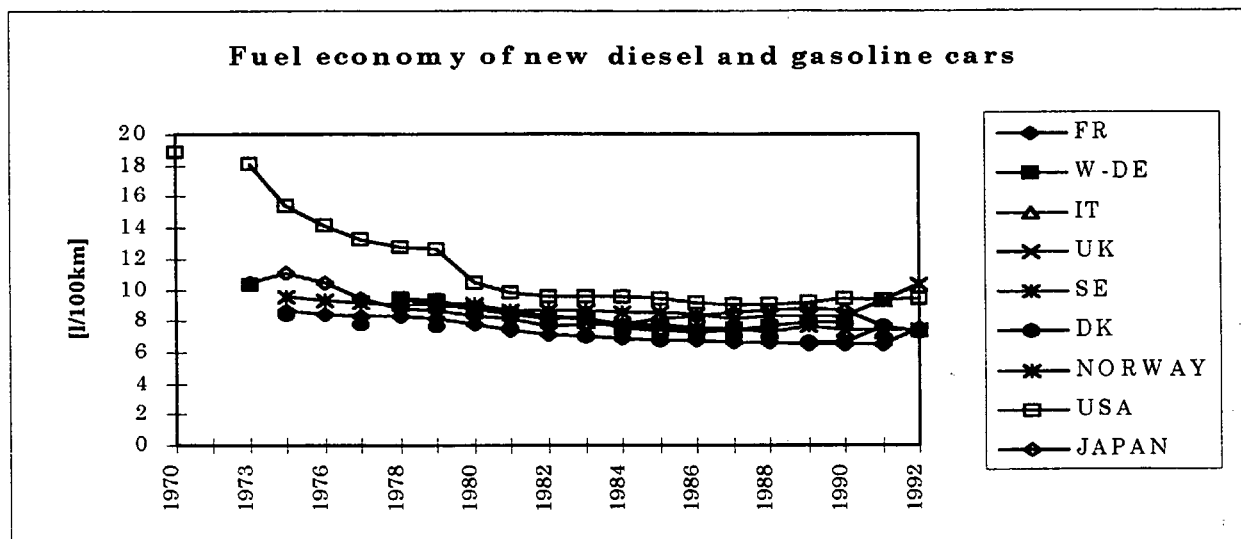

One of the main reasons for this lack of improvement of new passenger cars average on the road fuel economy is that the cars are heavier today than in the early 1970'es on average. It is well known, that one of the most important parameters for a cars energy use is its weight. Figure B-7 illustrate the importance of downsizing cars to make them more energy efficient. The figure is made on the basis of 50 selected cars sold on the Danish market in the late 1980'ties and early 1990'ties.

Today there are many car models available on the Danish market which use between 5,5 to 12 litres of petrol per kilometre on average. However the market for small energy efficient cars is not very big in Denmark. In the last years the car owners has preferred bigger cars with more powerful engines and heavier accessory loads. Therefore there is already a potential to improve the car fleets average fuel economy if the car buyers would buy the most energy efficient models already on the market today<sup>16</sup>.

However, in the short term it is not realistic to think that many of the car buyers will buy small cars in stead of big cars, but even though a car buyer wants to buy a big car there is quite large

<sup>15</sup> Schipper, Lee, "Determinants of automobile use and energy consumption in OECD countries", Annual review of energy and environment, 20:325-86, 1995.

<sup>16</sup> Vibe-Petersen, J., "Biler, energiforbrug og sikkerhed", Institut for Samfundsudvikling og planlægning, Aalborg University, 1993.

differences between the energy use of different car models within the same car weight class<sup>17</sup>. This potential can be better known to car buyers if the Danish government or the European Commission choose to start up campaigns such as environmental labelling of cars. The European Commission has advertised that environmental labelling of cars is a future policy incentive to be started up<sup>18</sup> and the Danish government is also interested in such a new incentive<sup>19</sup>.

**Figure B-7 (fuel efficiency based on ECE-norm):**

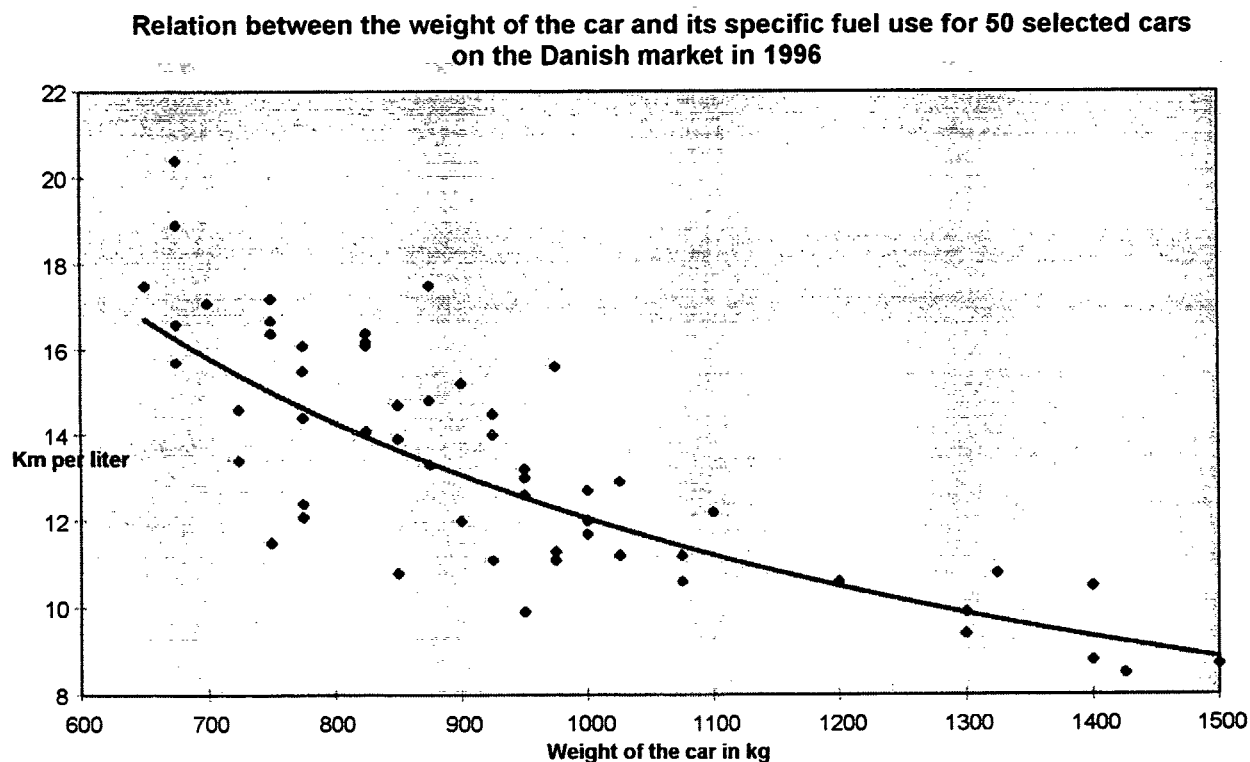

In Table B-1 we have listed a number of cars which, according to the Swedish organisation "Gröna bilister" are the most environmentally "friendly" in their classes in the Swedish market in 1996. They combine a high energy efficiency with a low level of harmful emissions. Such cars could be favoured in an environmental labelling campaign or by tax rebates compared to other cars in the same classes.

The Danish government is at the time being about to prepare a proposal on a new tax-scheme which will secure that energy efficient cars are taxed less than more energy consuming models. However the proposals presented by the government until now are not sufficient to change the behaviour of car buyers drastically. More efficient changes in the tax system has been proposed

<sup>17</sup> Kågeson, P og Gröna bilister, "Bakgrundsrapport till "Bästa miljöval bland 1996 års bilar", Gröna Bilister, 1996.

<sup>18</sup> Commission of the European communities, "Communication from the Commission to the Council and the European Parliament - a community strategy to reduce CO<sub>2</sub>-emissions from passenger cars and improve fuel economy", COM(95) 689 final, 1995.

<sup>19</sup> Trafikministeriet, "Regeringens handlingsplan for reduktion af transportsektorens CO<sub>2</sub>-udslip", 1996.

by FDM, Danish car owners association, and there seems to be political will to look into more radical changes of the tax system in the near future<sup>20</sup>.

**Table B-1: The least environmentally damaging cars of different classes in Sweden in 1996 according to the Swedish organisation "Gröna bilister"**<sup>21</sup>.

Car model	Fuel use (km/l)
<b>Small cars</b>	
Fiat Punto 55 S	18,2
Fiat Punto 75 S/SX	16,1
Ford Fiesta 1,3i	15,6
Hyundai Accent LS/GS/GLS	15,9
VW POLO 1,4i 3d/5d	15,9
<b>middle class cars</b>	
Citroen ZX Reflex 1,4i	14,3
Honda Civic 1,5i LS	16,4
Mazda 323 1,5	14,1
Opel Astra GL 1,6	15,9
Peugeot 306 XR 1,4 3d	15,2
Renault 19 RN	15,4
Toyota Corolla 1,3	15,4
VW Golf 1,4i	14,1
<b>Bigger middle class cars</b>	
Audi A4 1,6	13,2
Citroen Xantia 1,8i SX 16v	13,9
Fiat Tempra 1,6 SX	13,9
Hyundai Sonata 1,8 GLS	12,5
Mazda 626 2,0	13,0
Opel Vectra 2,0	12,8
Opel Calibra 2,0	13,2
Peugeot 405 2,0 GTX	12,7
Toyota Carina E 1,6/E 1,6 T	14,9
VW Passat CL 1,8i	12,3
<b>Big cars</b>	
BMW 523i	11,6
Chrysler Stratus 2,0 LE	13,3
Citroen XM 2,0i SX/Break	12,8
Mercedez Benz c180	11,4
Mercedez Benz E200/E230	11,4
Opel Omega GL 2,0i 8v	11,5
Peugeot 605 Sli	12,3
Rover 620 Ti	13,0
Rover 820 Ti	13,3
Volvo 850 S/SE 2,5	11,4
Volvo 850 GLT 2,5	11,2

<sup>20</sup> Interview with Joel Nielsen from the Danish ministry of taxes. Joel Nielsen is the advisor of the Danish minister of taxes.

<sup>21</sup> Kågeson, P og Gröna bilister, "Bakgrundsrapport till "Bästa miljöval bland 1996 års bilar", Gröna Bilister, 1996.

Possibly the most efficient way to influence the car buyers preferences to energy efficiency when buying a car would be to increase the fuel price drastically. Until now there has not been political acceptance of such a strategy in Denmark. There are several reasons for this. Consequently transport is considered as a very important parameter for the society's welfare, and the political will to reduce this welfare is therefore very little. Furthermore car transport is already heavily taxed compared to other commodities. Taxes on cars are among the highest in Europe and fuel taxes are well above the minimum taxes demanded by the European Community. It is well known that the Danish fuel taxes are mainly decided by the German fuel tax, as the Danish ministry of taxes finds it necessary to follow the German fuel price to prevent that the car users buy fuel in Germany. It seems that the recent political situation in Denmark prevents that Denmark will put more taxes on fuel unless Germany chooses to do so. Furthermore it is highly questionable whether a consensus can be reached to rise the minimum fuel taxes in EU above the Danish tax levels in the near future<sup>22</sup>. Though a general increase of the fuel taxes in the European union will be necessary to make energy efficient cars more attractive to the consumers.

Another way to promote heavier taxation on car travel is to implement a road pricing system. Such a system can possibly be introduced in Denmark without interfering with the European Community's directives. In this way there would not be a problem connected to the German fuel prices and it would furthermore be possible to regulate traffic in areas with big environmental problems such as Copenhagen by putting a higher tax on traffic in this region. Though road pricing systems are yet only under development and can not be implemented in Denmark in the near future<sup>23</sup>.

### **How to promote substantially more energy efficient car models in the future.**

The energy efficiency of cars can be substantially improved by technical means in the future. There are many technical improvements which can be implemented to reduce the energy efficiency of cars. These improvements can be classified into means which aims at improving the efficiency of the energy transmission in the car and means which aim at reducing the need for energy to accelerate the car. The most important parameters when improving the energy efficiency of cars are to optimise the energy efficiency of the engine and the mechanical energy transmission system. The most important parameters when reducing the need for energy to accelerate the car is to reduce the weight of the car, reduce the air drag, reduce rolling resistance and to reduce the amount of energy needed to heat and light the car.

Today most car manufacturers have produced prototype cars which are much less fuel consuming than today's average car. These cars only use 3-4 litres of fuel per 100 kilometres<sup>24</sup>. Compared to today's average on the road fuel economy in Denmark, where the average car use 8l per 100 kilometres, these prototype cars have the potential to reduce average fuel economy substantially if they are broadly introduced on the market.

The most important obstacle to the implementation of these very energy efficient cars in Denmark seems to be that they are not yet introduced on the market and that it is doubtful whether there is a big market for them. The car buyers seems to prefer bigger cars with more powerful engines and other facilities. Therefore it seems that the car fleet will not become

---

<sup>22</sup> Interview with Joel Nielsen from the Danish ministry of taxes. Joel Nielsen is the advisor of the Danish minister of taxes.

<sup>23</sup> Interview with Michael Soetmann from the Danish ministry of transport.

<sup>24</sup> Volks Wagen has for example developed the ECO-GOLF which has been produced in a few hundred copies untill now.

radically more energy effective without government incentives which could possibly secure that the car industry improves new cars average energy efficiency markedly, and that the consumers buy these cars.

The European Commission has announced that it will be necessary to make goals for the average fuel use of new cars in the future. The Commission has proposed to set a goal for the average fuel consumption per 100 kilometres average driving of petrol and diesel cars of 5l and 4,5l respectively in 2005. In the near future the Commission will negotiate with the European car industry to set a reasonable goal. The first reaction from the industry seems to have been that they think that the goal is more realistic to fulfil within 2010<sup>25</sup>. However the negotiations of this initiative are not yet finished so it is impossible to say what will be the precise goals for the future. However the initiative seems to be a very important incentive which have the potential to cut down the average fuel consumption of the Danish car fleet by approximately 40% before 2020. Of course it is still very uncertain whether the goal of the Commission for 2005 will be reached. Much depends on the actual will of the car industry to take up the challenge.

In a longer time perspective it will be necessary to produce cars which are much more energy efficient than the best prototypes today and probably also to use alternative sources of energy which can substitute diesel and petrol. The fuel substitution seems to be most important in cities with local environmental problems. One possible solution will be to produce substantially lighter cars made of ultra light materials such as carbon fibre. Such a car has, according to the American physicist Amory Lovins, the potential to reduce the cars energy need by a factor of 5-10 compared to today's average. However the "supercar" described by Amory Lovins will probably not be introduced on this side of 2020 at least.

#### **Future scope of improving energy efficiency of the Danish aircraft fleet.**

In the next five years SAS plans to expand the aircraft fleet from 107 aircraft in 1995 to 164 in 2000. As the new aircraft types are more energy efficient than the old ones SAS estimates that the average energy efficiency of the total fleet will become 20% more energy efficient by 2015 compared to today.

Even though the average fuel use per passenger kilometre in new aircraft has been reduced substantially through the last four decades there still seems to be considerable scope for further improvements in aircraft energy efficiency. Several studies indicate that there is a long term potential to reduce new aircraft fuel use by between 50% and 70% per passenger kilometre before 2050. Such substantial improvements might be possible if the air drag and weight to seat ratio of aircraft are reduced while the specific energy efficiency of jet engines is improved.

As airplanes have relatively long lifetimes of 20 to 30 years and even more it will take some time before the aircraft which are now in use will be replaced. However historical development has shown that the energy efficiency improvements of aircraft have been quite substantial with improvements in new aircraft efficiency of around 3,5% per annum<sup>26</sup>. One of the main reasons for this is that air traffic has grown dramatically leading to a growth in the total aircraft fleet.

<sup>25</sup> Interview with Erik Iversen from the Danish environmental department.

<sup>26</sup> Michaelis, L., "The transport sector in OECD Europe" in "Energy technologies to reduce CO2 emissions in Europe: Prospects, competition, synergy", Conference proceedings, Petten, the Netherlands, 11-12 april, IEA/OECD, 1994 and Sørensen, Bent, "Selected experiences on energy conservation and efficiency measures in other countries, that may be relevant to the Australian effort to reduce the greenhouse effect, COWI Consult, 1991 and Schipper, Lee: "Determinants of automobile use and energy consumption in OECD countries", Annual review of energy and environment, 20:325-86, 1995.

Each new generation of aircraft has shown great improvements in the specific fuel use per passenger kilometre. The substantial improvement has been achieved due to the high degree of competition between airline companies and also fuel costs relatively large share of operating costs. In 1991 fuel costs were about 15% of total operating costs. If the fuel expenses continuous to play a major role in airline companies total costs in the future the companies will certainly continue to demand more energy efficient aircraft. As air traffic is expected to continue to grow by at least 3-5% per year in the future the size of the aircraft fleet will continue to grow allowing the airline companies to buy the most energy efficient aircraft sold on the market. In this way the average energy efficiency will continue to grow even though the old aircraft will be used for many more years<sup>27</sup>.

**Table B-2: Expected future development in the SAS aircraft fleet<sup>28</sup>.**

Aircraft type	1995	1996	1997	1998	1999	2000
Douglas DC9-41	25	17				
Fokker F-28	19	16	16	14	8	
Boeing 767-300ER	13	14	15	15	15	15
Douglas DC9-21	4	4	4	4		
Douglas DC9-41 noise improved		7	24	21	20	20
Douglas MD81	31	31	31	31	31	31
Douglas MD82	12	12	12	12	16	16
Douglas MD83	2	2				
Fokker F-50	22	22	22	22	22	22
Boeing 737-3000C	2	2				
Douglas DC9-80	5	8	8	4		
Douglas MD87	16	18	18	18	16	16
Douglas MD90-30		4	8	8	8	8
Boeing 737-600				10	26	36
Total number:	107	124	142	145	154	164

Expected efficiency improvements of aircraft in the near future are the use of new materials for aircraft, ultra high bypass turbofan engines and a high number of seats (600-800 seats) in aircraft. In the long term new engine concepts like the prop-fan, a propeller with specially designed curved blades allowing high speed operation, is expected to raise efficiency further (see Figure B-8)<sup>29</sup>. Another technological development might be the use of advanced light weight heat exchangers, of a type not yet developed, to provide cooling and recuperate exhaust heat from the engine<sup>30</sup>. Furthermore the use of new fuel types like liquefied natural gas

<sup>27</sup> Behind this is the assumption that supersonic aircraft are not going to play a major role in the future. Supersonic aircraft are much more energy consuming than aircraft that cruise at speeds below the speed of sound. If the development allows the introduction of more supersonic aircraft the energy efficiency improvements will be lower than predicted here.

<sup>28</sup> SAS, "Miljøregnskab 1995", 1996.

<sup>29</sup> Grieb and Simon, "Pollutant emissions of existing and future engines for commercial aircraft" in Schumann, U (editor), "Air traffic and the environment - background and potential global atmospheric effects", Springer-Verlag, 1990.

<sup>30</sup> Michaelis, L., "The transport sector in OECD Europe in "Energy technologies to reduce CO2 emissions in Europe: Prospects, competition, synergy", Conference proceedings, Petten, the Netherlands, 11-12 april, IEA/OECD, 1994.

or hydrogen could in principle lower intensity as those fuels weigh less per unit of energy in the fuel<sup>31</sup>.

Figure B-8: Historic development in jet engine concept and future possibilities<sup>32</sup>.

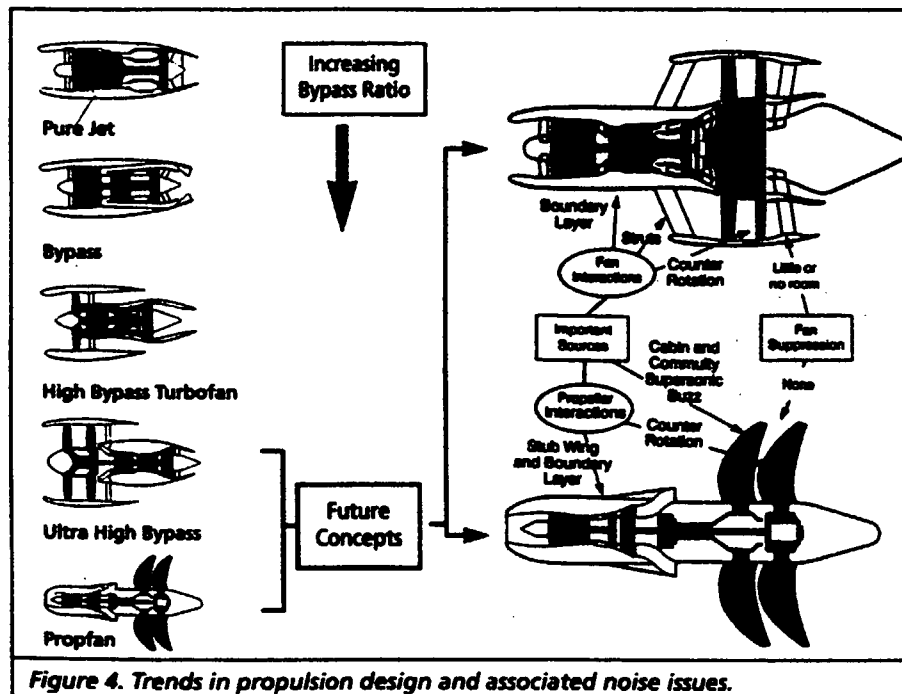

ICAO's (International Civil Aviation Organisation) prognoses for the development in new aircraft energy efficiency up to 2010 projects 2,5% yearly improvements until 2010. This is in line with other traffic scientists expectations. Martin and Schock from the English department of energy expects new aircraft to become 30% more energy efficient between 1989 and 2010: Laurie Michaelis, OECD, estimate that new aircraft will become 20%-30% more energy efficient before 2020, but estimate that the technical potential is rather 40%-60%.

In the longer term, after 2010, there is an even greater potential to improve aircraft energy efficiency. Both Laurie Michaelis and the German Enquete Commission estimates that there is a technical potential to reduce the energy intensity of airplanes by approximately 70%-80% in 2050. As can be seen in the Tables below some of the expected technologies are probably not going to be developed in the short term, and some of them are even unspecified.

#### Future scope of improving energy efficiency of the Danish train fleet.

For trains there also seems to be some potential to improve the energy efficiency in the future. The most important parameter will be to reduce the weight of the trains. It is not possible to say exactly how big the potential is, as it will depend very much on the materials used for the trains construction and the specific purpose with the train. Lots of factors influence the energy efficiency of trains, and DSB's plans for a future high speed train of course have the potential to make the energy use for longer trips rise.

<sup>31</sup> Carl-Jochen Winter, "Hydrogen for future aircraft" in Schumann, U (editor), "Air traffic and the environment - background and potential global atmospheric effects", Springer-Verlag, 1990.

<sup>32</sup> ICAO Journal, "Evolving noise issue could persist into the next century", M.J.T. Smith from Rolls Royce Company, august 1992.



**Table B-3: Future potential to increase energy efficiency of aircraft as predicted by the German Enquete-Kommision<sup>33</sup>.**

Year	Air drag	Aircraft weight	Potential fuel index after improving aircraft weight and air drag	Engine concept	Specific fuel consumption of the engine	Total fuel index per passenger
1990	100	100	100	3 <sup>rd</sup> generation Turbofan with conventional combustion chamber	100	100
2005	77	92	71	Shaded prop-fan fat less combustion chamber	80	57
2020	62	90	56	Shaded prop-fan with ICR core, LPB combustion chamber	68	38
2050	55	90	50	Not defined	57	29

**Table B-4: Technical and economic potential to improve aircraft energy efficiency as predicted by Michaelis<sup>34</sup>.**

Today's average energy use [MJ/pass-km]	1,5 MJ - 2,5 MJ
2010-2020 Expected improvement of energy efficiency [%]	20 % to 30%
2010-2020 Technical potential to improve energy efficiency if the aircraft should still be able to deliver the same performance as today [%]	40% til 60%
2010-2020 Technical potential if the aircraft performance is reduced [%]	70%
Ultimate technical reduction potential of aircraft energy use [%]	80%

In the near future it does not seem very plausible that the average energy efficiency of the Danish train fleet can be improved much more than what is expected as a consequence of the replacement of old train models with newer models. The expectations to the improvements in the energy efficiency of different passenger trains for different purposes in Denmark can be seen in Table B-5.

The energy efficiency improvements of the new Danish trains compared to the older models has mainly been achieved by lowering the weight to seat ratio of trains. This development is illustrated in Table B-6.

The trains which are to be put into service will probably be used for more than twenty years and maybe even much more. Therefore the energy efficiency of the train fleet will probably not be improved drastically beyond 2005 before around 2030. After this time it is very plausible that the train fleet will be replaced by more energy efficient train types.

<sup>33</sup> "Mobilität und Klima", Enquete-Kommision "Schutz der Erdatmosphäre" des Deutschen Bundestages, Economica Verlag, 1994.

<sup>34</sup> Michaelis, L., "The transport sector in OECD Europe in "Energy technologies to reduce CO<sup>2</sup> emissions in Europe: Prospects, competition, synergy", Conference proceedings, Petten, the Netherlands, 11-12 april, IEA/OECD, 1994.

**Table B-5: DSBs energy use in 1995 and the expected energy use in 2002<sup>35</sup>**

Passenger trains	Year	Energy	CO <sub>2</sub>	Efficiency improvement	Efficiency improvement
		MJ/person-km	g/person-km	Energy	CO <sub>2</sub>
Intercity	1995	0,52	36	23%	22%
	2002	0,40	28		
Fasttrain	1995	0,73	51	48%	47%
	2002	0,38	27		
International	1995	0,74	54	8%	7%
	2002	0,68	50		
Regional	1995	0,82	60	48%	47%
	2002	0,43	32		
S-train	1995	0,92	77	47%	52%
	2002	0,49	37		

**Table B-6: The weight of different train types in Denmark<sup>36</sup>**

	Built in	Number of passenger wagons	Length (meter)	Number of seats	Speed (max.) (km/h)	Fuel	Total Weight (1000 kg)	Weight per seat (kg)	Weight per meter (kg)
MZ-locomotive w/4 wagons	1977-78	4	119.0	240	140 (165)	Diesel	283	1.180	2.378
IC3	1989-	3	58.8	144	180 (>200)	Diesel	96	667	1,633
MR/MRD	1978-84	2	45.0	126	120	Diesel	69	548	1,533
IR4	1993-	4	76.5	243	180	El	129	531	1,686
2. generation S-trains	1966-78	4	81.2	260	100	El	144	554	1,773
4. generation S-trains	1995-	8	84.0	336	120	El	125	372	1,488

**Long term Potential to use renewable energy sources for personal transport in Denmark.**

Today practically all transportation modes for personal transport in Denmark are fuelled by energy based on fossil energy sources. Cars, busses, ferries and aircraft are petrol or diesel

<sup>35</sup> DSB, "Ny fart i miljøet, DSBs miljøstrategi mod år 2000", juni 1996, side 19.

<sup>36</sup> *ibid.*

fuelled as gas driven cars have been phased out in Denmark. Passenger trains are mainly diesel fuelled but in the future a bigger share of the train fleet will be electrical trains.

In Denmark there is a very large potential to use renewable energy sources both in the energy system in general and in the transportation sector. The biggest potential is without doubt to install large wind turbines on shore and especially off shore in the Danish waters. Several studies estimate, that the long term potential electricity production is far greater than the total electricity-use in Denmark today<sup>37</sup>. Besides this there is a considerable potential to exploit biomass residues and to plant bio-crops in large scale plantations solely for energy purposes. Finally there is a minor potential to install solar thermal heat collectors and photovoltaic panels to produce low temperature heat and electricity<sup>38</sup>.

Today only a marginal share of this potential is exploited in Denmark. It is reasonable to assume that the future will bring a higher penetration of these renewable energy technologies, as the production price per amount of energy derived from these technologies becomes lower than today. Of special interest to the transportation sector is the potential to produce wind- or solar electricity and liquid biofuels.

Wind turbines on-shore are already close to being cost competitive relative to coal based electricity plants in Denmark, and in the future the electricity production price is expected to drop considerably as the off-shore turbine technology is further developed.

There are only a few minor producers in the liquid biofuel field in Denmark today. The main reason is that biofuel production is not yet cost competitive to the traditional fossil fuels. A few producers claim to be able to start up production of biofuels in Denmark if the biofuels are allowed to have a total tax discount for a limited period of ten years to get the production started. The political party "Venstre" has made several proposals in the Danish parliament to give a total tax discount for a limited amount of biofuels for a limited period. According to "Venstre's" proposal the tax discount should be phased out gradually after some years as the production prices become lower. However it has not been possible to find a majority for the proposal in the Danish parliament<sup>39</sup>.

If the prices on fossil fuels rise in the future it will be economically sound to exploit the wind- and biomass sources in Denmark. If the prices on fossil fuels are doubled, for instance as a result of a very high tax on CO<sub>2</sub>-emissions, it is very plausible that a large fraction of the Danish energy system will be based on renewable energy sources. Therefore it is of interest to explore how big the societally acceptable potential to exploit renewable sources could possibly be in a long term perspective. As illustrated in the matrix below we think that the long term potential is very big compared to today's energy consumption if the prices on fossil fuels are approximately doubled within a short term period from today<sup>40</sup>.

<sup>37</sup> Stefan Krüger Nielsen and Bent Sørensen, "Long term integration of renewable energy sources into the european energy system, and its potential economic and environmental impacts - the fair market scenario", IMFUFA, Roskilde University, EC project APAS/RENA-CT94-0041, 1996.

<sup>38</sup> *ibid.*

<sup>39</sup> Stefan Krüger Nielsen et al, "Tekniske muligheder for at reducere transportsektorens CO<sub>2</sub>-udslip", TEK-SAM, Roskilde University, Thesis to be published in February 1997.

<sup>40</sup> *ibid.*

**Table B-7: Total societally acceptable potential to produce energy from renewable sources in a long term perspective (year 2050) [TWh/Year]<sup>41</sup>.**

	On-shore wind el.	Offshore wind el.	Biomass residues	Biomass from plantations	Solar thermal heat	PV elec.	Total potential	1990 DK final energy use	1990 DK final transport energy use
DK	29	110	5	15	1	2	162	143	52

**The need for future improvements of the energy efficiency and use of renewable energy for persons transport in Denmark.**

As described in the text above there is a large scale potential to improve the energy efficiency of persons transport and to exploit renewable energy sources in Denmark in a long term perspective. However it is highly questionable whether these potentials will be realised with the low prices on fossil fuels in Denmark today. The prices on jet fuel for aircraft and heavy diesel oil for ferries are especially low as there is no tax on these fuels in Denmark today. Furthermore the fossil fuels for road transport has been more than halved, in 1995 prices, compared to the price in the early 1970'ties. It is therefore necessary to rise the prices on fossil fuels if the energy efficiency of persons transport is to be improved markedly and the use of renewable sources should be further exploited in the future.

The Danish ministry of transport illustrates, in the ministry's new energy plan, how the CO<sub>2</sub>-emissions in Denmark will rise in the future if the price on fossil fuels remain at the same level as today in the future (in 1995 prices)<sup>42</sup>. The ministry has made assumptions for the future growth in the amount of transport by different modes and the expected energy efficiency improvements which can be expected to be realised if the price on fossil fuels remain at the same level as today.

The ministry's expectations to energy efficiency can be seen in Table B-8. The ministry of transport assume that new diesel- and petrol cars, busses, ferries and aircraft will be approximately 20% more energy effective before 2030 while new electrified passenger trains are assumed to be more than 40% less energy consuming in the same period. These expectations to future improvements in the specific energy efficiency of transport modes are based on the assumption, that the price on fossil energy fuels will remain at the same level as today until 2030.

The expectations to future efficiency improvements in passenger cars specific energy consumption by 2030 presented by the ministry of transport are less progressive than the goal put out by the European Commission, which represents a reduction in the average specific energy use of new passenger cars sold in Europe of approximately 30-40%, compared to today's average, before 2005 and 2010 at the latest<sup>43</sup>.

<sup>41</sup> Stefan Krüger Nielsen and Bent Sørensen, "Long term integration of renewable energy sources into the european energy system, and its potential economic and environmental impacts - the fair market scenario", IMFUFA, Roskilde University, EC project APAS/RENA-CT94-0041, 1996.

<sup>42</sup> Trafikministeriet, "Regeringens handlingsplan for reduktion af transportsektorens CO<sub>2</sub>-udslip", 1996.

<sup>43</sup> Commission of the European Communities, "Communication from the Commission to the Council and the European Parliament - a community strategy to reduce CO<sub>2</sub>-emissions from passenger cars and improve fuel economy", COM(95) 689 final, 1995.

**Table B-8: The Danish ministry of transports assumptions for future improvements in the energy efficiency of different modes of transport for personal transport between 1995 and 2030 as a result of the assumption that energy prices remains at the same level as today until 2030<sup>44</sup>.**

	Petrol	Diesel	Electricity
Passenger car	22%	20%	
Bus		22%	
Passenger train			44%
Ferry		20%	
Passenger aircraft	22%		

Besides this the Danish ministry of transport has not assumed that any part of the energy used for transport in Denmark in 2030 will be delivered by renewable energy technologies. The result of their scenario for the Danish transport sector in 2030 is therefore, that the total energy use for transport will be 28% higher in 2030 than it was the case in 1988 if the prognosis of future growth in the demand for transport and the assumptions for future energy efficiency mentioned earlier in this text are actually realised. The conclusion in the action plan from the ministry of transport is that stronger measures, e.g. higher fuel taxes or road pricing, will have to be put into play if the CO<sub>2</sub>-emissions from the Danish transport sector should be stalled<sup>45</sup>.

Figure B-9 illustrates the expected growth in the total amount of transport, the expected energy use if the transport modes becomes more energy efficient and the actual goal of the Danish government. As can be seen in the figure the governments goal could actually be reached with the efficiency assumptions in question if the amount of transport is stalled at the 1994 level. However the most realistic development in the use of energy for personal transport in Denmark is that the energy use will rise by 28% until 2030. The governments goal is actually a 25% reduction in 2030.

#### **An alternative scenario.**

As illustrated in Figure B-9 the Danish governments' goals for reduction of the CO<sub>2</sub>-emissions from personal transport can not be reached with the energy prices seen today. Therefore we have made a scenario for the Danish energy consuming sectors with the assumption that the energy prices are doubled in a near future.

If the fuel prices becomes twice as high as today the individual transport users and transport companies will probably demand more energy effective transportation modes. In such a situation we are convinced that it will be possible to improve the energy efficiency of the different transport modes much more than expected by the Danish ministry of transport. As illustrated in Table 9 below we have assumed that road transport will be four times as efficient in 2050, rail and air transport will be twice as efficient and water ways transport will be 25% more efficient.

<sup>44</sup> Trafikministeriet, "Regeringens handlingsplan for reduktion af transportsektorens CO<sub>2</sub>-udslip", 1996.

<sup>45</sup> *ibid.*

Figure B-9<sup>46</sup>:

Example of the difference between the expected development and the governments goals for CO<sub>2</sub>-reductions in Denmark.

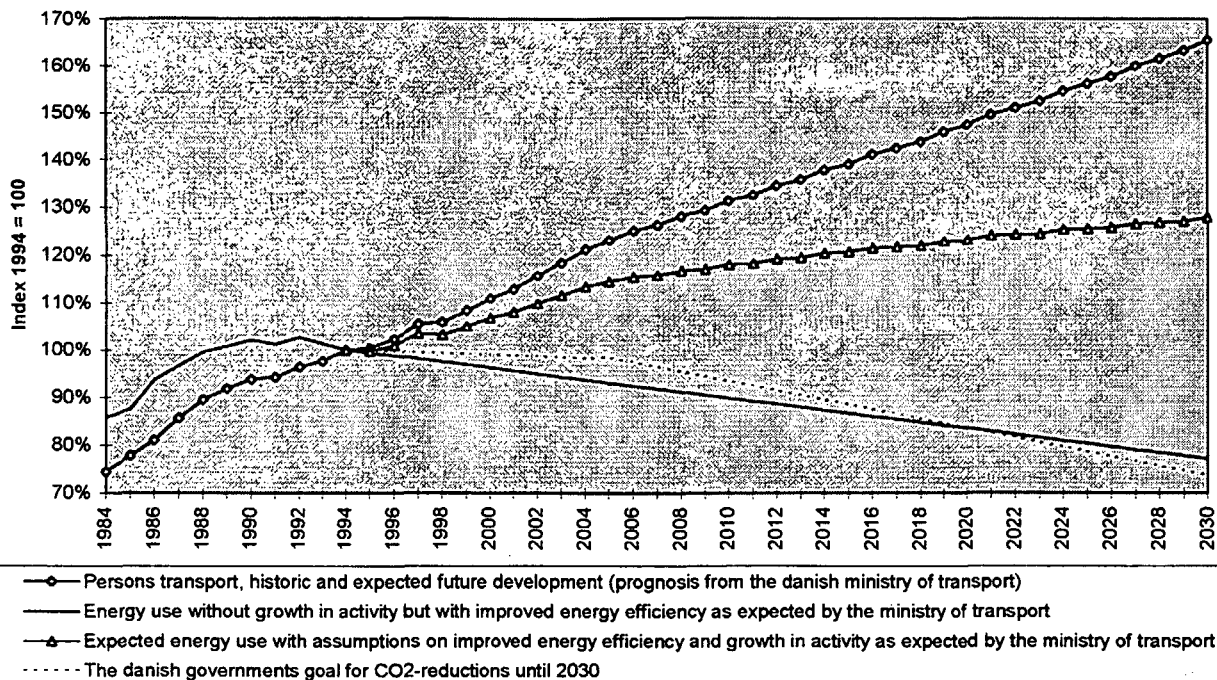

Our assumptions for the possible future efficiency improvements of different modes of transportation are based on the assumption that the most advanced engine technology already known today are used while effort is done to use advanced light weight materials for the body shells of cars and trains.

**Table B-9: Assumptions for the improvements in the energy efficiency of different modes of transport as a result of a doubling of the prices on fossil fuels in general (FMS)<sup>47</sup>.**

	1990	2000	2010	2030	2050
Transport sector					
Road	1,00	1,00	0,50	0,33	0,25
Rail	1,00	1,00	1,00	0,75	0,50
Air	1,00	1,00	1,00	0,75	0,50
Water ways	1,00	1,00	1,00	0,75	0,75

If the production prices for different kinds of renewable energy technologies are lowered gradually in the next 54 years and the price on fossil fuels is doubled in a near future it seems plausible that most of Denmark's energy system will be based on renewable energy sources in 2050 (see Figure B-10 and Table B-7).

In the transport sector we assume that it will be necessary to use lots of electric cars to solve the local environmental problems in the biggest Danish cities. Therefore half of the energy

<sup>46</sup>Trafikministeriet, "Regeringens handlingsplan for reduktion af transportsektorens CO<sub>2</sub>-udslip", 1996.

<sup>47</sup> Stefan Krüger Nielsen and Bent Sørensen, "Long term integration of renewable energy sources into the European energy system, and its potential economic and environmental impacts - the fair market scenario", IMFUFA, Roskilde University, EC project APAS/RENA-CT94-0041, 1996.

used for road transport is electricity. The other half is assumed to be liquid biofuels. Trains are expected to use electricity and ferries and aircraft are expected to use fossil fuels like today.

We expect the total amount of transport by different transport modes to grow a little bit slower than what is expected by the ministry of transport (except for rail which we expect to grow much faster). The reason why we have expected a little less growth in the total amount of transport is that the prices on fossil fuels is doubled. However the difference between our scenario and that of the ministry of transport is not very big. We find that this is reasonable as the higher efficiency improvements in our scenario will eventually lead to lower fuel costs than today, if measured per kilometre transported.

**Table B-10: Our assumptions on the future growth in the amount of transport if the prices on fossil fuels are doubled in a near future.**

	1990	2000	2010	2020	2030	2040	2050
Transport sector							
Road	1,00	1,20	1,44	1,56	1,61	1,60	1,50
Rail	1,00	1,00	1,05	1,10	1,21	1,33	1,46
Air	1,00	1,33	1,67	2,00	2,33	2,67	3,00
Waterways	1,00	1,10	1,21	1,33	1,40	1,46	1,50

**Figure B-10: Illustration of the Danish energy system in 2050<sup>48</sup> (FMS).**

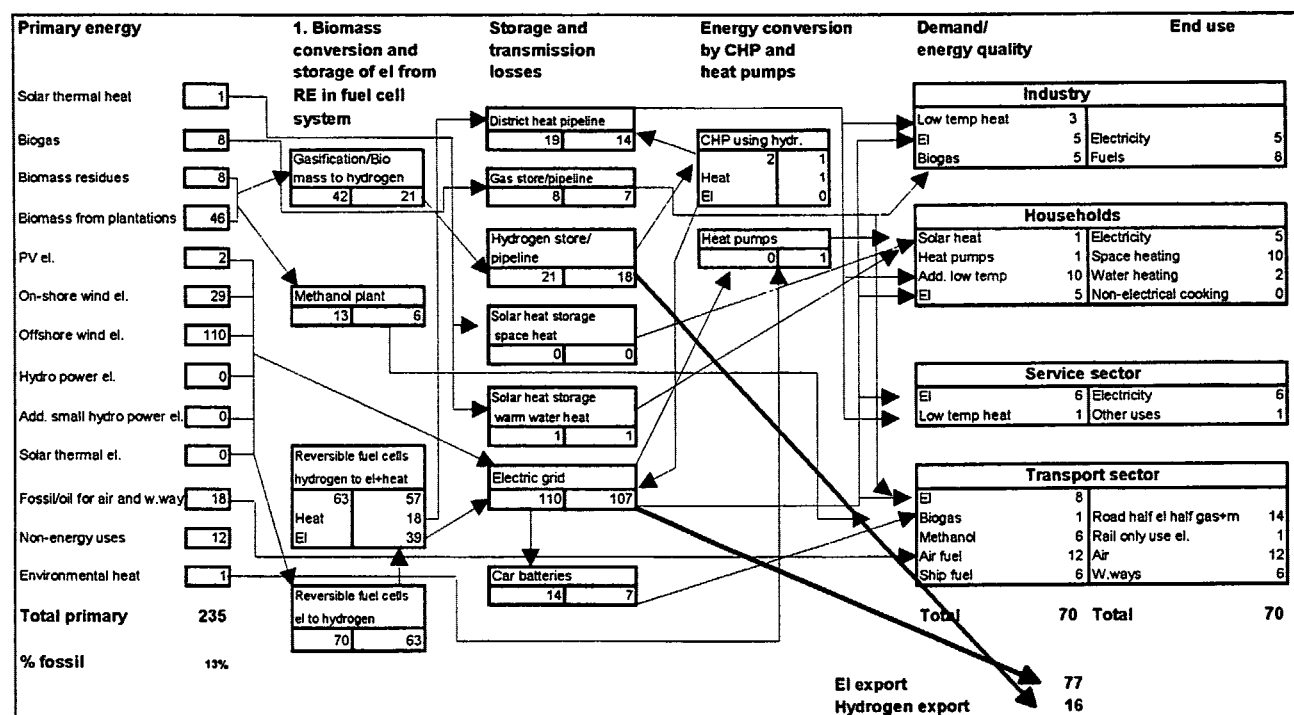

One of the conclusions from our work with the alternative scenario model is that there is a considerable potential to improve the energy efficiency of personal transport and to use

<sup>48</sup> Stefan Krüger Nielsen and Bent Sørensen, "Long term integration of renewable energy sources into the European energy system, and its potential economic and environmental impacts - the fair market scenario", IMFUFA, Roskilde University, EC project APAS/RENA-CT94-0041, 1996.

renewable energy for transportation in Denmark in the future if the prices on fossil fuels are doubled. The reduction goals of the Danish government should therefore be possible to fulfil if there is political will to rise the price on fossil fuels. That is the open question today.

### Literature to Appendix B.

#### *Possibilities to produce liquid biofuels in Denmark.*

1. Andersen et. al.: "Forslag til handlingsplan for forskning, udvikling og demonstration vedrørende anvendelse af biomasse til motorbrændstoffer i Danmark", 1993.
2. Breinholt et. al.: "Flydende brændstoffer af biomasse - muligheder i Danmark", Energiforskningsprogrammet, 1992.
3. Dansk bioenergi, juni 1994, nr. 15.
4. Dansk Gasteknisk Center: "Sammenligning af motorbrændstoffers miljøpåvirkninger", Teknisk note nr. 4/1995, 1995.
5. Dansk Teknologisk Institut: "Anvendelse af rapsolie-methylester som brændstof til busdrift", DTI Auto- og Motorteknik, 1993.
6. Energistyrelsen: "Danmarks vedvarende energiressourcer", 1996.
7. Energistyrelsen: "Bioenergi Udviklingsprogram", 1995.
8. Jørgensen, Kaj: "Alternative drivmidler og bæredygtig udvikling - forprojekt rapport", Fysisk Institut, DTU, 1993.
9. Kiel, Pauli m.fl.: Etanol i det grønne bioraffinaderi, Sydjysk Universitetsforlag, 1994.
10. Landbrugsministeriet: "Kortlægning af virkningerne ved anvendelse af energiafgrøder", udarbejdet af en interministeriel arbejdsgruppe fra Energiministeriet, Miljøministeriet og Landbrugsministeriet, september 1994.
11. Miljø- og Energiministeriet: "Energi 21 - Regeringens energihandlingsplan 1996", 1996.
12. Notat udarbejdet af Bruno Sander Nielsen, Landbrugsrådet d. 8/2-1995.
13. Notat udarbejdet af Bruno Sander Nielsen, Landbrugsrådet, d. 2. september 1993.
14. OTA, "Energy technology choices - shaping our future", Congress of the United States office of technology assessment, 1991.
15. Statens Jordbrugs- og Fiskeriøkonomiske Institut: "Halm og energiafgrøder - analyser af økonomi, energi og miljø", 1996.
16. Stefan Krüger Nielsen and Bent Sørensen, "Long term integration of renewable energy sources into the European energy system, and its potential economic and environmental impacts - the fair market scenario", IMFUFA, Roskilde University, EC project APAS/RENA-CT94-0041, 1996.

#### *Passenger trains.*

1. DSB: "Ny fart i miljøet, DSBs miljøstrategi mod år 2000", juni 1996
2. DSB: "Plan i Miljøet, DSBs miljøberetning 1994"
3. DSB: "Fart i miljøet, DSB miljøplan 1992"
4. DSB: "Fart i miljøet, DSB miljøplan - bilagsrapport 1992"
5. DSB: "Materielhåndbog"
6. DSB: "Årsberetning 1995"
7. ABB, pjecer vedrørende IC3 og IR4
8. Linke-Hoffmann-Busch/Siemens, energidiagrammer for de nye S-tog
9. NærumBanen, materiale vedrørende Regiosprinter



*Aircraft for passenger transportation.*

1. Wegener P.P., "What makes airplanes fly? - History, science, and applications of aerodynamics", Springer Verlag, 1991.
2. SAS, "Miljøregnskab 1995", 1996.
3. SAS, "Årsregnskab 1995", 1996.
4. Toft, P., "Flytrafikkens oversete miljøproblem-- et speciale om den civile flytrafiks indvirkning på drivhuseffekten og forandringer i ozonlaget forårsaget af emissionerne af NOx og vanddamp. International regulering og regimeteori", TEK-SAM, RUC, 1995.
5. Enquete-Kommission "Schutz der Erdatmosphäre" des Deutschen Bundestages, "Mobilität und Klima", Economica Verlag, 1994.
6. Michaelis, L., "The transport sector in OECD Europe" in "Energy technologies to reduce CO<sub>2</sub> emissions in Europe: Prospects, competition, synergy", Conference proceedings, Petten, the Netherlands, 11-12 april, IEA/OECD, 1994.
7. Schipper, Lee: "Determinants of automobile use and energy consumption in OECD countries", Annual review of energy and environment, 20:325-86, 1995.
8. ICAO Journal, "Standards for aircraft noise, emissions focus of meeting on environmental issues", by Les Mortimer ICAO's secretariat, march 1996.
9. ICAO Journal, "Application of new technologies to airframe, systems and engines improve trijet's performance", Jim Bouey, Mac Donnell Douglas aircraft company, january/february 1996.
10. ICAO Journal, "Designers contemplating the task of developing an engine to power proposed 600-seat airliners", John Cundy, Rolls-Royce PLC, january/february 1996.
11. ICAO Journal, "Engines developed for heavy twinjet offer important improvements over predecessors", Baldev K. Mehta from Boeing Commercial Airplane Group, march 1995.
12. ICAO Journal, "ICAO projects long-term moderate traffic growth of 5 per cent per year", ICAO Secretariat, december 1994.
13. ICAO Journal, "1944-1994 - a half century of technological change and progress", Les Mortimer ICAO Secretariat, september 1994.
14. ICAO Journal, "Medium-term forecasts project progressive increases in scheduled passenger traffic", ICAO Secretariat, july/august 1993.
15. ICAO Journal, "European environmental studies focus on impact of engine emissions", Colin Thame from UK Department of Transport, august 1992.
16. ICAO Journal, "Evolving noise issue could persist into the next century", M.J.T. Smith from Rolls Royce Company, august 1992.
17. ICAO Journal, "ICAO analyses trends in fuel consumption by world's airlines", By Boris Balashov and Andrew Smith from ICAO Air Transport Bureau, august 1992.

*Passenger cars.*

1. Bang, J.R. et al, "Energiforbruk og relative CO<sub>2</sub>-utslipp ved utvinning, produksjon, distribusjon og bruk av tradisjonelle- og alternative drivstoffer - en helhetlig vurdering (versjon 2), avdeling for kjøretøYTEknikk, Teknologisk Institut, Norge, 1991.
2. Commission of the European communities, "Communication from the commission to the council and the European parliament - a Community strategy to reduce CO<sub>2</sub> emissions from passenger cars and improve fuel economy", COM(95) 689 final, Brussels, 1995.
3. COWI consult, "Energiforbrug ved individuel og kollektiv trafik i bygader", 1993.
4. DTI, "Teknologikatalog - energibesparelser i transportsektoren", udført for Trafikministeriet, 1995.

5. DTI, "Muligheder for brændstofbesparelse i personbiler og mindre varebiler", Dansk Teknologisk Institut, Afd. for auto- og motorteknik, 1991.
6. Grøna bilister, "De miljømæssigt bedste bilarna av 1994/95 års modeller", Grøna bilister og European Federation for Transport & Environment (T&E), 1994.
7. Enquete Kommission "Schutz der erdatmosphäre" des Deutschen Bundestages, "Mobilität und Klima - wege zu einer klimaverträglichen Verkehrspolitik", Economica Verlag, 1994.
8. IEA (International Energy Agency), "Energy and environmental technologies to respond to global climate change concerns", 1994.
9. IEA (International Energy Agency), "Fuel efficiency of passenger cars", 1991.
10. IEA (International Energy Agency), "Low consumption/low emission automobile - proceedings of an expert panel in Rome", Paris, 1991.
11. Jørgensen, Kaj, "Grøn vækst i transportsektoren - eller grønlig?", i Det økologiske råds årsrapport 1995-96.
12. Lovins, A.B. et al, "Supercars - the coming light-vehicle revolution", Rocky Mountain Institute, 1993.
13. Martin and shock, "Energy use and energy efficiency in UK transport up to the year 2010", Energy efficiency office, UK Department of energy, 1989.
14. Michaelis, L, "The transport sector in OECD Europe", in "Energy technologies to reduce CO<sub>2</sub>emissions in Europe: Prospects, competition, synergy", Conference proceedings, Petten, the Netherlands, 11-12 april, IEA/OECD, 1994.
15. Moore, T.C. and A.B. Lovins, "Vehicle design strategies to meet and exceed PNGV goals", SAE Special publications 1105, 1995.
16. OECD, ECMT and ENERGY 2000, "Transport, energy and the urban environment - social marketing of promising strategies", 1994.
17. Riley, R.Q., "Alternative cars in the 21st century - a new personal transportation paradigm", 1994.
18. Schipper, Lee, "Determinants of automobile use and energy consumption in OECD countries", Annual review of energy and environment, 20:325-86, 1995.
19. Sørensen, Bent, "Energy conservation and efficiency measures in other countries", A series of greenhouse studies number 8, COWI consult, 1991.
20. Sørensen, Bent, "Fremtidens vedvarende energisystem", Teknologinævnet, 1994.
21. Trafikministeriet, "Transport, energi og CO<sub>2</sub>-emissioner - debatoplæg", 1995.
22. Trafikministeriet, "Referencemodel for den danske transportsektor 1988-2030", COWI consult, 1990.
23. Vibe-Petersen, J., "Nye bilers energiforbrug og sikkerhed", Institut for Samfundsudvikling og planlægning, 1991.
24. Grøn Information, "Tænk på miljøet når du køber bil", af Claus Bruun, 1995.
25. Ecotraffic, "The life of fuels - motor fuels from source to end use - an energy and emissions systems study of conventional and future options", Stockholm, 1992.
26. RISØ, "Inventory of Emissions to the Air from Danish Sources 1972-1992", by Jørgen Fennhann og Niels A. Kilde, System Analysis Department, RISØ, 1994.
27. Vibe-Petersen, J., "Biler, energiforbrug og sikkerhed", Institut for Samfundsudvikling og planlægning, 1993.
28. European Commission, "Corinair - Technical annexes volume 2 - Default emission factors handbook", Directorate-General Environment, Nuclear Safety and Civil Protection, 1994.
29. RISØ, "Computer programme to calculate emissions from road traffic 1992", af Niels A Kilde, Afdelingen for systemanalyse, RISØ, 1992.

30. RISØ, "Computer programme to calculate emissions from road traffic 1993", af Niels A Kilde, Afdelingen for systemanalyse, RISØ, 1993.
31. Danmarks Statistik, "Emissioner fra vejtrafikken 1993", 1995.
32. Kågeson, P, "Laboratory testing of 31 car models - an analysis of emissions from cars subjected to heavy loads and a supplementary test cycle", European Federation for Transport and Environment, 1995.
33. Kågeson, P og Gröna bilister, "Bakgrundsrapport till "Bästa miljöval bland 1996 års bilar"", Gröna Bilister, 1996.
34. Konsumentverket, "Brochure med oplysninger om alle bilmodeller på det svenske marked i 1995 og miljøklassificeringer af hver enkelt bil", 1995.
35. Daimler Benz, "NECAR II - driving without emissions", informationsmateriale om Mercedes' nye brintbil.
36. Daihatsu, "Electric vehicles and Daihatsu", informationsmateriale om Daihatsus elbilprogram.
37. Elsbett-konstruktion GmbH, "Elsbett plant oil engines", informationsmateriale om Elsbettmotoren.
38. Honda, "Honda electric vehicle", informationsmateriale om Hondas elbilprogram.
39. Informationsmateriale fra VW, "Så miljøvenlig er Golf Ecomatic".
40. Volkswagen, "Commercial vehicles for future traffic needs", Wolfsburg 1992.
41. AUDI, "Interim report - environmental protection at AUDI", 1993.
42. Volkswagen, "Golf with diesel/electric hybriddrive", informationsmateriale fra VW.
43. Volkswagen, "Öko-Golf", informationsmateriale fra VW.
44. Volkswagen, "Alternative energien und innovative antriebskonzepte", informationsmateriale fra VW om diesel-, gas-, bio-, öko- og hybridprogrammerne.
45. Danish Energy Agency, "Cross country comparison of energy efficiency indicators, phase II: Denmark", 1995.
46. Ademe, "Cross country comparison of energy efficiency indicators - phase I final report", 1994.

Liste over tidligere udkomne tekster  
tilsendes gerne. Henvendelse herom kan  
ske til IMFUFA's sekretariat  
tlf. 46 75 77 11 lokal 2263

- 
- 217/92 "Two papers on APPLICATIONS AND MODELLING  
IN THE MATHEMATICS CURRICULUM"  
by: Mogens Niss
- 218/92 "A Three-Square Theorem"  
by: Lars Kadison
- 219/92 "RUPNOK - stationær strømning i elastiske rør"  
af: Anja Boisen, Karen Birkelund, Mette Olufsen  
Vejleder: Jesper Larsen
- 220/92 "Automatisk diagnosticering i digitale kredsløb"  
af: Bjørn Christensen, Ole Møller Nielsen  
Vejleder: Stig Andur Pedersen
- 221/92 "A BUNDLE VALUED RADON TRANSFORM, WITH  
APPLICATIONS TO INVARIANT WAVE EQUATIONS"  
by: Thomas P. Branson, Gestur Olafsson and  
Henrik Schlichtkrull
- 222/92 On the Representations of some Infinite Dimensional  
Groups and Algebras Related to Quantum Physics  
by: Johnny T. Ottesen
- 223/92 THE FUNCTIONAL DETERMINANT  
by: Thomas P. Branson
- 224/92 UNIVERSAL AC CONDUCTIVITY OF NON-METALLIC SOLIDS AT  
LOW TEMPERATURES  
by: Jeppe C. Dyre
- 225/92 "HATMODELLEN" Impedansspektroskopi i ultrarent  
en-krystallinsk silicium  
af: Anja Boisen, Anders Gorm Larsen, Jesper Varmer,  
Johannes K. Nielsen, Kit R. Hansen, Peter Bøggild  
og Thomas Hougaard  
Vejleder: Petr Viscor
- 226/92 "METHODS AND MODELS FOR ESTIMATING THE GLOBAL  
CIRCULATION OF SELECTED EMISSIONS FROM ENERGY  
CONVERSION"  
by: Bent Sørensen

- 227/92 "Computersimulering og fysik"  
af: Per M.Hansen, Steffen Holm,  
Peter Maibom, Mads K. Dall Petersen,  
Pernille Postgaard, Thomas B.Schrøder,  
Ivar P. Zeck  
Vejleder: Peder Voetmann Christiansen
- 228/92 "Teknologi og historie"  
Fire artikler af:  
Mogens Niss, Gens Høyrup, Ib Thiersen,  
Hans Hedal
- 229/92 "Masser af information uden betydning"  
En diskussion af informationsteorien  
i Tor Nørretranders' "Mærk Verden" og  
en skitse til et alternativ baseret  
på andenordens kybernetik og semiotik.  
af: Søren Brier
- 230/92 "Vinklens tredeling - et klassisk  
problem"  
et matematisk projekt af  
Karen Birkelund, Bjørn Christensen  
Vejleder: Johnny Ottesen
- 231A/92 "Elektron diffusion i silicium - en  
matematisk model"  
af: Jesper Voetmann, Karen Birkelund,  
Mette Olufsen, Ole Møller Nielsen  
Vejledere: Johnny Ottesen, H.B.Hansen
- 231B/92 "Elektron diffusion i silicium - en  
matematisk model" Kildetekster  
af: Jesper Voetmann, Karen Birkelund,  
Mette Olufsen, Ole Møller Nielsen  
Vejledere: Johnny Ottesen, H.B.Hansen
- 232/92 "Undersøgelse om den simultane opdagelse  
af energiens bevarelse og isærdeles om  
de af Mayer, Colding, Joule og Helmholtz  
udførte arbejder"  
af: L.Arleth, G.I.Dybkjær, M.T.Østergård  
Vejleder: Dorthe Posselt
- 233/92 "The effect of age-dependent host  
mortality on the dynamics of an endemic  
disease and  
Instability in an SIR-model with age-  
dependent susceptibility  
by: Viggo Andreasen
- 234/92 "THE FUNCTIONAL DETERMINANT OF A FOUR-DIMENSIONAL  
BOUNDARY VALUE PROBLEM"  
by: Thomas P. Branson and Peter B. Gilkey
- 235/92 OVERFLADESTRUKTUR OG POREUDVIKLING AF KOKS  
- Modul 3 fysik projekt -  
af: Thomas Jessen
-

- 236a/93 INTRODUKTION TIL KVANTE HALL EFFEKTEN  
af: Anja Boisen, Peter Bøggild  
Vejleder: Peder Voetmann Christiansen  
Erland Brun Hansen
- 236b/93 STRØMSSAMMENBRUD AF KVANTE HALL EFFEKTEN  
af: Anja Boisen, Peter Bøggild  
Vejleder: Peder Voetmann Christiansen  
Erland Brun Hansen
- 237/93 The Wedderburn principal theorem and Shukla cohomology  
af: Lars Kadison
- 238/93 SEMIOTIK OG SYSTEMEGENSKABER (2)  
Vektorbånd og tensorer  
af: Peder Voetmann Christiansen
- 239/93 Valgsystemer - Modelbygning og analyse  
Matematik 2. modul  
af: Charlotte Gjerrild, Jane Hansen, Maria Hermannsson, Allan Jørgensen, Ragna Clauson-Kaas, Poul Lützen  
Vejleder: Mogens Niss
- 240/93 Patologiske eksempler.  
Om sære matematiske fisks betydning for den matematiske udvikling  
af: Claus Dræby, Jørn Skov Hansen, Runa Ulsøe Johansen, Peter Meibom, Johannes Kristoffer Nielsen  
Vejleder: Mogens Niss
- 241/93 FOTOVOLTAISK STATUSNOTAT 1  
af: Bent Sørensen
- 242/93 Brovedligholdelse - bevar mig vel  
Analyse af Vejdirektoratets model for optimering af broreparationer  
af: Linda Kyndlev, Kare Fundal, Kamma Tulinius, Ivar Zeck  
Vejleder: Jesper Larsen
- 243/93 TANKEEKSPERIMENTER I FYSIKKEN  
Et 1.modul fysikprojekt  
af: Karen Birkelund, Stine Sofia Korremann  
Vejleder: Dorte Posselt
- 244/93 RADONTRANSFORMATIONEN og dens anvendelse i CT-scanning  
Projektrapport  
af: Trine Andreassen, Tine Guldager Christiansen, Nina Skov Hansen og Christine Iversen  
Vejledere: Gestur Olafsson og Jesper Larsen
- 245a+b /93 Time-Of-Flight målinger på krystallinske halvledere  
Specialerapport  
af: Linda Szkotak Jensen og Lise Odgaard Gade  
Vejledere: Petr Viscor og Niels Boye Olsen
- 246/93 HVERDAGSVI DEN OG MATEMATIK - LÆREPROCESSER I SKOLEN  
af: Lena Lindenskov, Statens Humanistiske Forskningsråd, RUC, IMFUFA
- 247/93 UNIVERSAL LOW TEMPERATURE AC CONDUCTIVITY OF MACROSCOPICALLY DISORDERED NON-METALS  
by: Jeppe C. Dyre
- 248/93 DIRAC OPERATORS AND MANIFOLDS WITH BOUNDARY  
by: B. Booss-Bavnbek, K.P.Wojciechowski
- 249/93 Perspectives on Teichmüller and the Jahresbericht Addendum to Schappacher, Scholz, et al.  
by: B. Booss-Bavnbek  
With comments by W.Abikoff, L.Ahlfors, J.Cerf, P.J.Davis, W.Fuchs, F.P.Gardiner, J.Jost, J.-P.Kahane, R.Lohan, L.Lorch, J.Radkau and T.Söderqvist
- 250/93 EULER OG BOLZANO - MATEMATISK ANALYSE SET I ET VIDENSKABSTEORETISK PERSPEKTIV  
Projektrapport af: Anja Juul, Lone Michelsen, Tomas Højgård Jensen  
Vejleder: Stig Andur Pedersen
- 251/93 Genotypic Proportions in Hybrid Zones  
by: Freddy Bugge Christiansen, Viggo Andreassen and Ebbe Thue Poulsen
- 252/93 MODELLERING AF TILFÆLDIGE FÆNOMENER  
Projektrapport af: Birthe Friis, Lisbeth Helmgård, Kristina Charlotte Jakobsen, Marina Mosbæk Johannessen, Lotte Ludvigsen, Mette Hass Nielsen
- 253/93 Kuglepakning  
Teori og model  
af: Lise Arleth, Kåre Fundal, Nils Kruse  
Vejleder: Mogens Niss
- 254/93 Regressionsanalyse  
Materiale til et statistikkursus  
af: Jørgen Larsen
- 255/93 TID & BETINGET UAFHÆNGIGHED  
af: Peter Harremoës
- 256/93 Determination of the Frequency Dependent Bulk Modulus of Liquide Using a Piezo-electric Spherical Shell (Preprint)  
by: T. Christensen and N.B.Olsen
- 257/93 Modellering af dispersion i piezoelektriske keramikker  
af: Pernille Postgaard, Jannik Rasmussen, Christina Specht, Mikko Østergård  
Vejleder: Tage Christensen
- 258/93 Supplerende kursusmateriale til "Lineære strukturer fra algebra og analyse"  
af: Mogens Brun Heefelt
- 259/93 STUDIES OF AC HOPPING CONDUCTION AT LOW TEMPERATURES  
by: Jeppe C. Dyre
- 260/93 PARTITIONED MANIFOLDS AND INVARIANTS IN DIMENSIONS 2, 3, AND 4  
by: B. Booss-Bavnbek, K.P.Wojciechowski

- 261/93 OPGAVESAMLING  
Bredde-kursus i Fysik  
Eksamensopgaver fra 1976-93
- 262/93 Separability and the Jones  
Polynomial  
by: Lars Kadison
- 263/93 Supplerende kursusmateriale til  
"Lineære strukturer fra algebra  
og analyse" II  
af: Mogens Brun Heefelt
- 264/93 FOTOVOLTAISK STATUSNOTAT 2  
af: Bent Sørensen
- 
- 265/94 SPHERICAL FUNCTIONS ON ORDERED  
SYMMETRIC SPACES  
To Sigurdur Helgason on his  
sixtyfifth birthday  
by: Jacques Faraut, Joachim Hilgert  
and Gestur Olafsson
- 266/94 Kommensurabilitets-oscillationer i  
laterale supergitre  
Fysikspeciale af: Anja Boisen,  
Peter Bøggild, Karen Birkelund  
Vejledere: Rafael Taboryski, Poul Erik  
Lindelof, Peder Voetmann Christiansen
- 267/94 Kom til kort med matematik på  
Eksperimentarium - Et forslag til en  
opstilling  
af: Charlotte Gjerrild, Jane Hansen  
Vejleder: Bernhelm Booss-Bavnbek
- 268/94 Life is like a sewer ...  
Et projekt om modellering af aorta via  
en model for strømning i kloakrør  
af: Anders Marcussen, Anne C. Nilsson,  
Lone Michelsen, Per M. Hansen  
Vejleder: Jesper Larsen
- 269/94 Dimensionsanalyse en introduktion  
metaprojekt, fysik  
af: Tine Guldager Christiansen,  
Ken Andersen, Nikolaj Hermann,  
Jannik Rasmussen  
Vejleder: Jens Højgaard Jensen
- 270/94 THE IMAGE OF THE ENVELOPING ALGEBRA  
AND IRREDUCIBILITY OF INDUCED REPRE-  
SENTATIONS OF EXPONENTIAL LIE GROUPS  
by: Jacob Jacobsen
- 271/94 Matematikken i Fysikken.  
Opdaget eller opfundet  
NAT-BAS-projekt  
vejleder: Jens Højgaard Jensen
- 272/94 Tradition og fornyelse  
Det praktiske eleverarbejde i gymnasiets  
fysikundervisning, 1907-1988  
af: Kristian Hoppe og Jeppe Guldager  
Vejledning: Karin Beyer og Nils Hybel
- 273/94 Model for kort- og mellemdistanceløb  
Verifikation af model  
af: Lise Fabricius Christensen, Helle Pilemann,  
Bettina Sørensen  
Vejleder: Mette Olufsen
- 274/94 MODEL 10 - en matematisk model af intravenøse  
anæstetikas farmakokinetik  
3. modul matematik, forår 1994  
af: Trine Andreasen, Bjørn Christensen, Christine  
Green, Anja Skjoldborg Hansen, Lisbeth  
Helmgard  
Vejledere: Viggo Andreasen & Jesper Larsen
- 275/94 Perspectives on Teichmüller and the Jahresbericht  
2nd Edition  
by: Bernhelm Booss-Bavnbek
- 276/94 Dispersionsmodellering  
Projektrapport 1. modul  
af: Gitte Andersen, Rehannah Borup, Lisbeth Friis,  
Per Gregersen, Kristina Vejre  
Vejleder: Bernhelm Booss-Bavnbek
- 277/94 PROJEKTARBEJDSPÆDAGOGIK - Om tre tolkninger af  
problemorienteret projektarbejde  
af: Claus Flensted Behrens, Frederik Voetmann  
Christiansen, Jørn Skov Hansen, Thomas  
Thingstrup  
Vejleder: Jens Højgaard Jensen
- 278/94 The Models Underlying the Anaesthesia  
Simulator Sophus  
by: Mette Olufsen(Math-Tech), Finn Nielsen  
(RISØ National Laboratory), Per Føge Jensen  
(Herlev University Hospital), Stig Andur  
Pedersen (Roskilde University)
- 279/94 Description of a method of measuring the shear  
modulus of supercooled liquids and a comparison  
of their thermal and mechanical response  
functions.  
af: Tage Christensen
- 280/94 A Course in Projective Geometry  
by Lars Kadison and Matthias T. Kromann
- 281/94 Modellering af Det Cardiovasculære System med  
Neural Puls kontrol  
Projektrapport udarbejdet af:  
Stefan Frello, Runa Ulsøe Johansen,  
Michael Poul Curt Hansen, Klaus Dahl Jensen  
Vejleder: Viggo Andreasen
- 282/94 Parallele algoritmer  
af: Erwin Dan Nielsen, Jan Danielsen,  
Niels Bo Johansen

- 283/94 Grænser for tilfældighed  
(en kaotisk talgenerator)  
af: Erwin Dan Nielsen og Niels Bo Johansen
- 284/94 Det er ikke til at se det, hvis man ikke  
lige ve' det!  
Gymnasiematematikens begrundelsesproblem  
En specialerapport af Peter Hauge Jensen  
og Linda Kyndlev  
Vejleder: Mogens Niss
- 285/94 Slow coevolution of a viral pathogen and  
its diploid host  
by: Viggo Andreassen and  
Freddy B. Christiansen
- 286/94 The energy master equation: A low-temperature  
approximation to Bässler's random walk model  
by: Jeppe C. Dyre
- 287/94 A Statistical Mechanical Approximation for the  
Calculation of Time Auto-Correlation Functions  
by: Jeppe C. Dyre
- 288/95 PROGRESS IN WIND ENERGY UTILIZATION  
by: Bent Sørensen
- 289/95 Universal Time-Dependence of the Mean-Square  
Displacement in Extremely Rugged Energy  
Landscapes with Equal Minima  
by: Jeppe C. Dyre and Jacob Jacobsen
- 290/95 Modellering af uregelmæssige bølger  
Et 3.modul matematik projekt  
af: Anders Marcussen, Anne Charlotte Nilsson,  
Lone Michelsen, Per Mørkegaard Hansen  
Vejleder: Jesper Larsen
- 291/95 1st Annual Report from the project  
LIFE-CYCLE ANALYSIS OF THE TOTAL DANISH  
ENERGY SYSTEM  
an example of using methods developed for the  
OECD/IEA and the US/EU fuel cycle externality study  
by: Bent Sørensen
- 292/95 Fotovoltaisk Statusnotat 3  
af: Bent Sørensen
- 293/95 Geometridiskussionen - hvor blev den af?  
af: Lotte Ludvigsen & Jens Frandsen  
Vejleder: Anders Madsen
- 294/95 Universets udvidelse -  
et metaprojekt  
Af: Jesper Duelund og Birthe Friis  
Vejleder: Ib Lundgaard Rasmussen
- 295/95 A Review of Mathematical Modeling of the  
Controlled Cardiovascular System  
By: Johnny T. Ottesen
- 296/95 RETIKULER den klassiske mekanik  
af: Peder Voetmann Christiansen
- 297/95 A fluid-dynamical model of the aorta with  
bifurcations  
by: Mette Olufsen and Johnny Ottesen
- 298/95 Mordet på Schrödingers kat - et metaprojekt om  
to fortolkninger af kvantemekanikken  
af: Maria Hermannsson, Sebastian Horst,  
Christina Specht  
Vejledere: Jeppe Dyre og Peder Voetmann Christiansen
- 299/95 ADAM under figenbladet - et kig på en samfunds-  
videnskabelig matematisk model  
Et matematisk modelprojekt  
af: Claus Dræby, Michael Hansen, Tomas Højgård Jensen  
Vejleder: Jørgen Larsen
- 300/95 Scenarios for Greenhouse Warming Mitigation  
by: Bent Sørensen
- 301/95 TOK Modellering af træers vækst under påvirkning  
af ozon  
af: Glenn Møller-Holst, Marina Johannessen, Birthe  
Nielsen og Bettina Sørensen  
Vejleder: Jesper Larsen
- 302/95 KOMPRESSORER - Analyse af en matematisk model for  
aksialkompressorer  
Projektrapport af: Stine Bøggild, Jakob Hilmer,  
Pernille Postgaard  
Vejleder: Viggo Andreassen
- 303/95 Masterlignings-modeller af Glasovergangen  
Termisk-Mekanisk Relaksation  
Specialerapport udarbejdet af:  
Johannes K. Nielsen, Klaus Dahl Jensen  
Vejledere: Jeppe C. Dyre, Jørgen Larsen
- 304a/95 STATISTIKNOTER Simple binomialfordelingsmodeller  
af: Jørgen Larsen
- 304b/95 STATISTIKNOTER Simple normalfordelingsmodeller  
af: Jørgen Larsen
- 304c/95 STATISTIKNOTER Simple Poissonfordelingsmodeller  
af: Jørgen Larsen
- 304d/95 STATISTIKNOTER Simple multinomialfordelingsmodeller  
af: Jørgen Larsen
- 304e/95 STATISTIKNOTER Mindre matematisk-statistisk opslagsværk  
indeholdende bl.a. ordforklaringer, resuméer og  
tabeller  
af: Jørgen Larsen

- 305/95 The Maslov Index:  
A Functional Analytical Definition  
And The Spectral Flow Formula  
  
By: B. Booss-Bavnbek, K. Furutani
- 306/95 Goals of mathematics teaching  
  
Preprint of a chapter for the forthcoming International Handbook of Mathematics Education (Alan J. Bishop, ed)  
  
By: Mogens Niss
- 307/95 Habit Formation and the Thirdness of Signs  
  
Presented at the semiotic symposium  
  
The Emergence of Codes and Intensions as a Basis of Sign Processes  
  
By: Peder Voetmann Christiansen
- 308/95 Metaforer i Fysikken  
  
af: Marianne Wilcken Bjerregaard, Frederik Voetmann Christiansen, Jørn Skov Hansen, Klaus Dahl Jensen Ole Schmidt  
  
Vejledere: Peder Voetmann Christiansen og Petr Viscor
- 309/95 Tiden og Tanken  
En undersøgelse af begrebsverdenen Matematik udført ved hjælp af en analogi med tid  
  
af: Anita Stark og Randi Petersen  
  
Vejleder: Bernhelm Booss-Bavnbek
- 
- 310/96 Kursusmateriale til "Lineære strukturer fra algebra og analyse" (E1)  
  
af: Mogens Brun Heefelt
- 311/96 2nd Annual Report from the project  
LIFE-CYCLE ANALYSIS OF THE TOTAL DANISH ENERGY SYSTEM  
  
by: Hélène Connor-Lajambe, Bernd Kuemmel, Stefan Krüger Nielsen, Bent Sørensen
- 312/96 Grassmannian and Chiral Anomaly  
  
by: B. Booss-Bavnbek, K.P. Wojciechowski
- 313/96 THE IRREDUCIBILITY OF CHANCE AND THE OPENNESS OF THE FUTURE  
  
The Logical Function of Idealism in Peirce's Philosophy of Nature  
  
By: Helmut Pape, University of Hannover
- 314/96 Feedback Regulation of Mammalian Cardiovascular System  
  
By: Johnny T. Ottesen
- 315/96 "Rejsen til tidens indre" - Udarbejdelse af a + b et manuskript til en fjernsynsudsendelse + manuskript  
  
af: Gunhild Hune og Karina Goyle  
  
Vejledere: Peder Voetmann Christiansen og Bruno Ingemann
- 316/96 Plasmaoscillation i natriumklynger  
  
Specialerapport af: Peter Meibom, Mikko Østergård  
  
Vejledere: Jeppe Dyre & Jørn Borggreen
- 317/96 Poincaré og symplektiske algoritmer  
  
af: Ulla Rasmussen  
  
Vejleder: Anders Madsen
- 318/96 Modelling the Respiratory System  
  
by: Tine Guldager Christiansen, Claus Dråby  
  
Supervisors: Viggo Andreassen, Michael Danielsen
- 319/96 Externality Estimation of Greenhouse Warming Impacts  
  
by: Bent Sørensen
- 320/96 Grassmannian and Boundary Contribution to the -Determinant  
  
by: K.P. Wojciechowski et al.
- 321/96 Modelkompetencer - udvikling og afprøvning af et begrebsapparat  
  
Specialerapport af: Nina Skov Hansen, Christine Iversen, Kristin Troels-Smith  
  
Vejleder: Morten Blomhøj
- 322/96 OPGAVESAMLING  
  
Bredde-Kursus i Fysik 1976 - 1996
- 323/96 Structure and Dynamics of Symmetric Diblock Copolymers  
  
PhD Thesis  
  
by: Christine Maria Papadakis
- 324/96 Non-linearity of Baroreceptor Nerves  
  
by: Johnny T. Ottesen
- 325/96 Retorik eller realitet ?  
  
Anvendelser af matematik i det danske Gymnasiums matematikundervisning i perioden 1903 - 88  
  
Specialerapport af Helle Pilemann  
  
Vejleder: Mogens Niss
- 326/96 Bevisteorier  
Eksemplificeret ved Gentzens bevis for konsistensen af teorien om de naturlige tal  
  
af: Gitte Andersen, Lise Mariane Jeppesen, Klaus Frovin Jørgensen, Ivar Peter Zeck  
  
Vejledere: Bernhelm Booss-Bavnbek og Stig Andur Pedersen
- 327/96 NON-LINEAR MODELLING OF INTEGRATED ENERGY SUPPLY AND DEMAND MATCHING SYSTEMS  
  
by: Bent Sørensen
- 328/96 Calculating Fuel Transport Emissions  
  
by: Bernd Kuemmel



329/96 The dynamics of cocirculating influenza strains conferring partial cross-immunity and

A model of influenza A drift evolution

by: Viggo Andreasen, Juan Lin and Simon Levin

330/96 LONG-TERM INTEGRATION OF PHOTOVOLTAICS INTO THE GLOBAL ENERGY SYSTEM

by: Bent Sørensen

331/96 Viskøse fingre

Specialerapport af:

Vibeke Orlien og Christina Specht

Vejledere: Jacob M. Jacobsen og Jesper Larsen

332/97 ANOMAL SWELLING AF LIPIDE DOBBELTLAG

Specialerapport af:

Stine Sofia Korremann

Vejleder: Dorthe Posselt

333/97 Biodiversity Matter

an extension of methods found in the literature on monetisation of biodiversity

by: Bernd Kuemmel