

On the Prosodic Hierarchy and Tone Sandhi in Mandarin

Lisa Lai Shen Cheng

1. Introduction

Third tone sandhi (3TS) is a process in Mandarin Chinese that changes a third tone (3) into a second tone (2) when it is immediately followed by a third tone. However, 3TS does not apply across the board. The question that arises is whether 3TS is sensitive to syntactic structure, prosodic structure or a combination of both? Several proposals have been made concerning the particular domain in which the rule applies, Cheng (1973)–the Cyclic Approach, Kaisse (1985)–the Branch Condition and Shih (1985)–the Prosodic Approach.

In this paper, I too will examine this question, focussing on the mapping between syntax and phonology in third tone sandhi. I will first discuss the inadequacy of the syntactic approaches of Cheng (1973) and Kaisse (1985), showing that a direct mapping from the syntax to the phonology does not provide proper domain for 3TS application. Further, I will examine the prosodic analysis proposed by Shih (1985), showing that her analysis does not account for all the possible tone patterns. In Section 4, I introduce Hayes' (1984) prosodic framework, in which a prosodic constituency is constructed from the syntactic structures, but in which the syntax–phonology relationship is non-isomorphic. I then propose a prosodic hierarchy in Mandarin Chinese, showing that this can account for the variation found in the tone patterns in Mandarin.

In short, there is no direct mapping from syntax onto phonology. Instead, prosodic structures which are constructed on the basis of syntactic constituency provide the correct domain for the 3TS process in Mandarin Chinese.

2. Direct Mapping between Syntax and Phonology

Both (Cheng 1973) and Kaisse (1985) maintain that the domain of 3TS application is syntactic. They propose that 3TS applies directly to syntactic structures in a cyclic fashion.

1987 "On the prosodic hierarchy and tone sandhi in Mandarin," in
P. Avery (ed.) *Toronto Working Papers in Linguistics 7*,
Linguistic Graduate Course Union, University of Toronto, p.
24-52.

filename = 5_349_27 (Letteren_Cheng, Lisa)

24-52

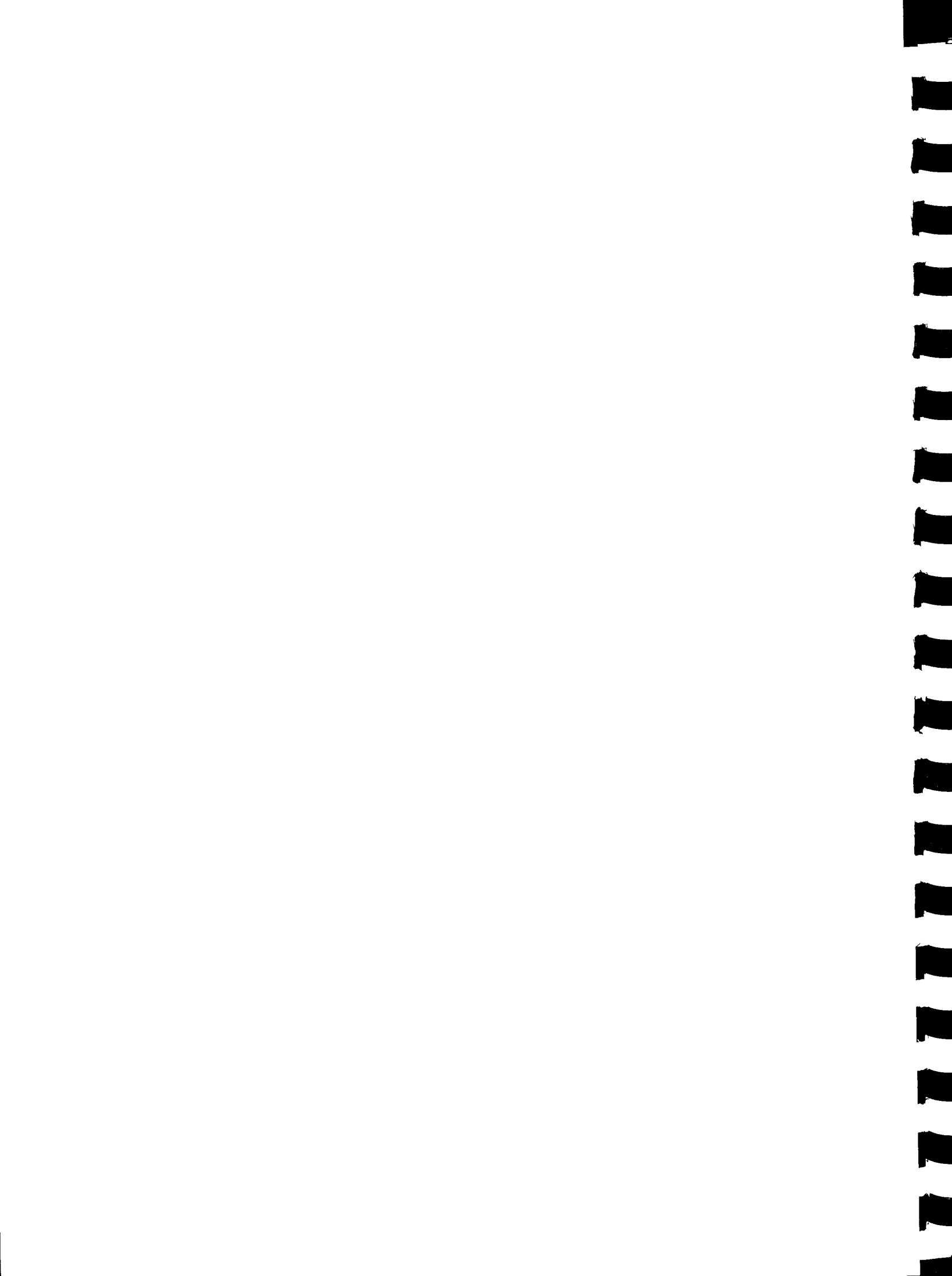

2.1. The Cyclic Approach (Cheng 1973)

In the cyclic approach, the 3TS rule applies phrase cyclically; that is, it first applies to the smallest syntactic phrases and then progressively to larger phrases. Thus, the rule starts from the most embedded constituent and it observes syntactic constituency.

The following data show that cyclic application of the rule can account for a large amount of data.

(1) wo da ni
 I hit you
 3 3 3 underlying tones (UT)
 3 2 3 surface tones (ST)
 'I hit you.'

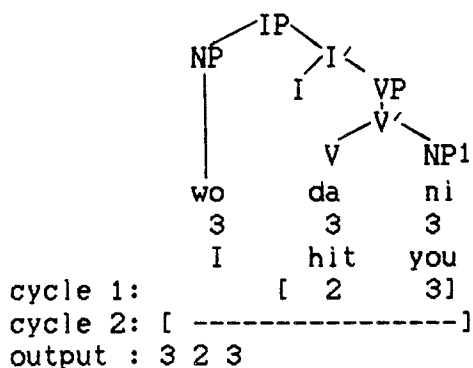

(2) wo ba bi gei ni
 I BA2 pen give you
 3 3 3 3 3 UT
 3 2 3 2 3 ST
 'I gave you the pen.'

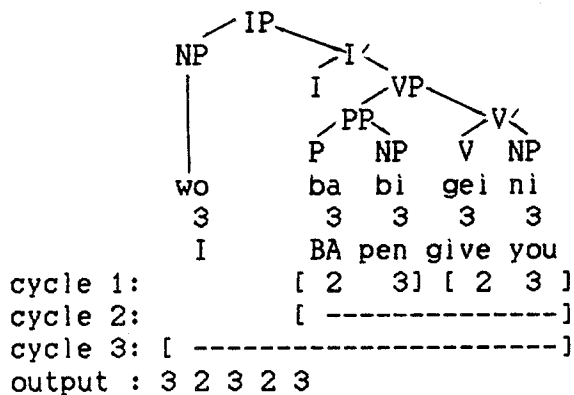

However, it is not at all difficult to find examples that the Cyclic Approach cannot account for. Sentences such as (3a) and (4a) pose problems for the Cyclic Approach.

(3)a. wo xiang yang xiao ma.
 I want raise little horse
 3 3 3 3 3 UT
 2 2 3 2 3 ST
 'I want to raise a pony.'

The Cyclic Approach would yield the following derivation:

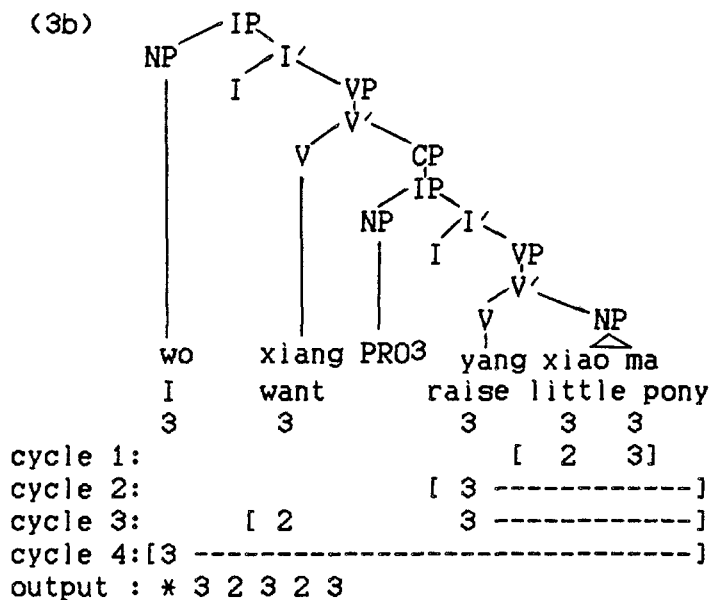

Similarly, in (4), cyclic application of 3TS generates incorrect surface tones.

(4) wo zhun ni yang xiao ma.
 I allow you raise little horse
 3 3 3 3 3 3 UT
 3 2 2 3 2 3 ST
 'I allow you to raise a pony.'

The cyclic approach has the following derivation:

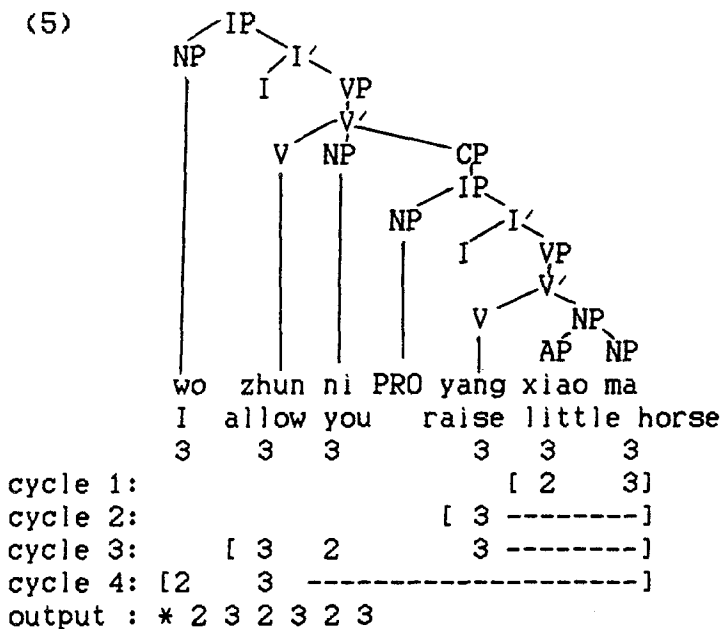

Thus, it is clear that the Cyclic Approach does not generate the correct tone patterns.

2.2. Kaisse (1985) Approach

Kaisse states that Mandarin 3TS applies to structure (6) and (7), but not (8):

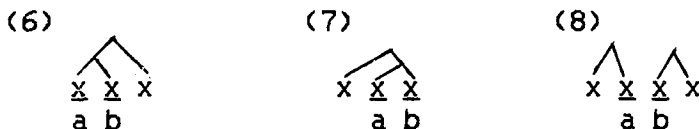

Thus, Kaisse proposes the Branch Condition stated in (9):

- (9) "Tone Sandhi may apply between two words a and b if a is the left branch of the constituent that contains b or if b is the right branch of the constituent that contains a; in other words, tone sandhi applies if the sandhi pair is on an edge of the constituent that contains it." (p.175)

Note that the tone sandhi pair (a,b) in structure (8) does not satisfy the Branch Condition because a is not the left branch of the constituent that contains b; nor is b the right branch of the constituent that contains a. Thus, 3TS cannot apply.

According to Kaisse's proposal, 3TS applies cyclically to syntactic structures. Thus, it starts from the most embedded pairs. (10) and (11) are examples of 3TS application based on Kaisse's model.

(10)	[shui-guo] jiu	'[water-fruit] wine=fruit wine'
	3 3 3	UT
	2 3 ---	cycle 1
	2 2 3	cycle 2
	2 2 3	ST

(11)	[xiao [lao-shu]]	'[small [old-rat]]=small rat'
	3 3 3	UT
	--- 2 3	cycle 1
	-----	cycle 2
	3 2 3	ST

However, as Shih (1985) points out, the Branch Condition wrongly predicts that 3TS does not apply to the tone sandhi pair underlined in (12) and (13).

(12)=(Shih's 54)

IP					
NP		I'			
		I		VP	
lao- <u>li</u>			V'		
old Li			V	ADJ N	
3 3			mai	hao jiu	
2 2			bought	good wine	
*2 3			3	3 3	UT
			3	2 3	ST
			3	2 3	ST derived from Kaisse's model
					'Old Li bought good wine.'

(13)=(Shih's 56)

NP					
QP		N'			
NUM	CL	ADJ	N		
san	<u>zhong</u>	<u>lan</u>	ren		
three	kind	lazy	people'		
1	3	3	2	UT	
1	2	3	2	ST	
*1	3	3	2	ST derived from Kaisse's model	
					'Three kinds of lazy people'

Also, the Branch Condition has problems in accounting for structures such as (14) which involve a direct object and indirect object.

(14)

```

      VP
     / \
    V   V'
   / \  / \
  NP AP NP N
 / \ / \
sung ni xiao mao
give you little cat
4  3  3  1      UT
4  2  3  1      ST
*4 3  3  1      ST derived from Kaisse's model
'give you a little cat'
    
```

In (14), [ni] 'you' cannot be considered the left branch of VP, and [xiao] 'little' cannot be considered the right branch of VP. Thus, according to the Branch Condition, 3TS should not apply. Yet, the tone pattern 4231 is perfectly normal.

Furthermore, the model Kaisse presents does not allow variations in tone patterns for any string of words. Thus, given (15), Kaisse's model predicts one and only one tonal pattern.

(15)

	ni	bi	gou	xiao.	
	you	compare	dog	small	
	3	3	3	3	UT
a.	3	2	2	3	ST
b.	2	2	2	3	ST
c.	2	3	2	3	ST

'You are smaller than the dog.'

As indicated in (15), there are three possible tone patterns and the syntactic structure (16) of the sentence shows that cyclic application of 3TS only generates one tone pattern: 3223 (15a).

(16)

```

      IP
     / \
    NP  I'
    |  / \
    ni I  V'
    3 / \  / \
    you compare dog xiao
       / \ / \
      PP NP V
     / \ / \
    P  NP V
   / \ / \
  ni bi gou xiao
  3  3  3  3
    
```

	ni	bi	gou	xiao	UT
	3	3	3	3	
	-----[2 3]-----				cycle 1
	-----[2 2 3]				cycle 2
	-----				cycle 3
	3	2	2	3	output

Purely syntactic approaches do not allow for variations of tone patterns. It is clear that a direct mapping from syntax onto phonology is not able to generate the correct tone patterns.

3. Shih's Model (1985)

Shih (1985) takes a different approach to Mandarin 3TS. She proposes an analysis where 3TS occurs within prosodic structures derived from syntactic structures, maintaining that "tone sandhi operates on 'prosodic structures' which are sensitive to, but by no means isomorphic to syntactic structures." (p.107)

Shih proposes that levels of foot, superfoot, and phrase are necessary to predict the correct application of 3TS. Foot formation is accomplished by the rule in (17).

(17) Foot Formation Rule (FFR)

i) Foot (f) construction

- a. IC (Immediate Constituency): Link immediate constituents into disyllabic feet.
- b. DM (Duple Meter): scanning from left to right, string together unpaired syllables into binary feet, unless they branch to the opposite direction.

ii) Super-foot (f') construction

Join any left over monosyllables to a neighbouring binary foot according to the direction of syntactic branching.

Thus, 3TS applies cyclically, first to feet (f), super-feet (f') then to phrases (p). The application of 3TS under Shih's model are shown in (18) and (19) below:

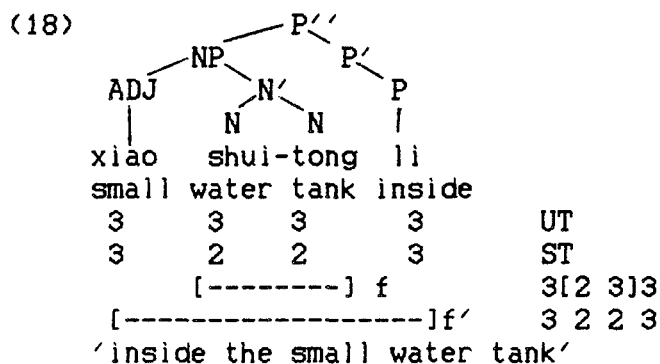

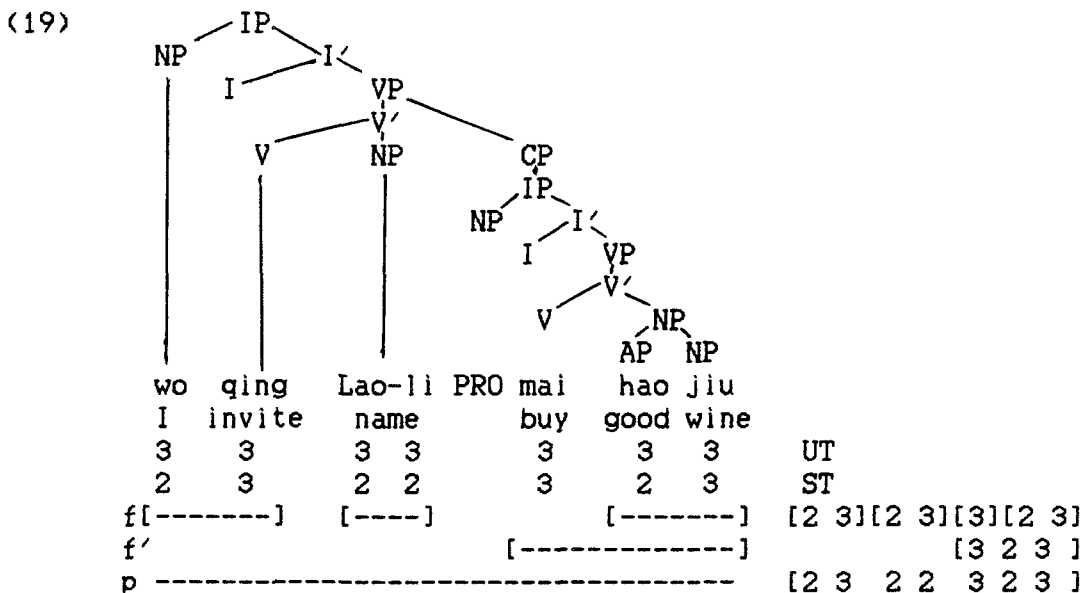

'I ask Lao-li to buy good wine.'

The prosodic structures in (18) and (19) are not isomorphic to the syntactic structures. Prosodic structures formed by foot construction and super-foot construction in Shih (1985) can account for the application of 3TS in many structures in Mandarin. However, as Shih points out, prepositional phrases seem to require extra conditions. Consider (20)-(23).

(20) ni bi wo xiao
 you compare I small
 3 3 3 3 UT
 a. 2 2 2 3 ST
 b. 3 2 2 3 ST
 c.*2 3 2 3 ST
 'You are smaller than I am.'

(21) ni ba gou da le.
 you BA dog hit-ASP
 3 3 3 3 UT
 a. 3 2 2 3 ST
 b. 2 2 2 3 ST
 c. 2 3 2 3 ST
 'You hit the dog.'

(22) gou bi ni xiao.
 dog compare you small
 3 3 3 3 UT
 a. 3 2 2 3 ST
 b. ?2 2 2 3 ST
 c. *2 3 2 3 ST
 'The dog is smaller than you are.'

(23) gou ba niao yao le.
 dog BA bird bite
 3 3 3 3 UT
 a. 3 2 2 3 ST
 b. 2 2 2 3 ST
 c. 2 3 2 3 ST
 'The dog bit the bird.'

(24)

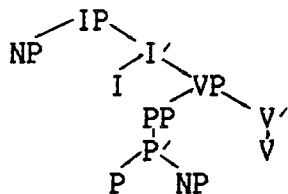

Despite the fact that (20)-(23) all share the syntactic structure shown in (24), 3TS does not apply in an identical manner. Therefore, the differences among these sentences cannot be attributed to syntactic constituency.

Shih's analysis as presented so far does not predict all the correct tone patterns for the above sentences. If feet are built according to the Foot Formation Rule (FFR-IC) and (FFR-DM) in (17), only some tone patterns can be derived. For example, only one tone pattern in (21) can be derived: (21a), as shown in (25).

(25) ni ba gou da le.
 you BA dog hit ASP 3 3 3 3 UT
 [-----] f - 2 3 -
 [-----] f' 3 2 2 3 (=21a)
 'You hit the dog.'

Shih suggests that tempo of speech may be a factor in the different readings in (20)-(23). She suggests that in normal speech, 3TS starts at the foot level. In a faster tempo, 3TS starts at f' level and in the fastest tempo, it starts at p-level. However, if various tone patterns are indeed due to rate of speech, only two tone patterns can be predicted for sentence (21), namely, (21a)- 3223, and

(21b)-2223. Given a faster rate of speech for sentence (21), 3TS starts at the superfoot (f') level as shown in (26).

(26) ni ba gou da le.
 you BA dog hit ASP 3 3 3 3 UT
 ----- f' 2 2 2 3 (=21b)
 'You hit the dog.'

While tempo may be a factor, Shih suggests another factor influencing readilgs in sentences like (20) to (23). That is, although these sentences share the same syntactic structure, there exists a major difference among them. In some sentences, the subject or object is a noun, in others, it is a pronoun. Based on these sentences, Shih proposes that FFR-IC does not apply to PPs with full NPs. Instead, quadrisyllabic strings will be separated into two prosodic feet by FFR-DM. Thus, (21) will have the prosodic structure (27).

(27) ni ba gou da le.
 you BA dog hit ASP 3 3 3 3 UT
 [----] [-----] f (DM) 2 3 2 3
 [-----] p 2 3 2 3 (=21c)
 'You hit the dog.'

Thus, only the tone pattern 2 3 2 3 (21c) can be derived.

However, it should be noted that sentence (21) has three possible tone patterns. If foot construction by IC (immediate constituency) cannot apply to PP with a full NP, the tone pattern (3223) cannot be generated. The problem of generating all possible tone patterns thus remains. Further, Shih does not discuss strings consisting of more than four syllables. Consider the tone patterns in (28)-(30).

(28) ni ba gou da shang-le.
 you BA dog hit wound ASP
 3 3 3 3 1 UT
 [----][-----] f(DM) 2 3 2 3 1
 [-----] f' 2 3 2 3 1
 ----- p 2 3 2 3 1(=c)
 a.3 2 2 3 1 ST
 b.2 2 2 3 1 ST
 c.2 3 2 3 1 ST
 'You hit-wounded the dog.'

(29) ni-de gou ba niao yao-shang le.
 your dog BA bird bite-wounded
 3 0 3 3 3 3 1 UT
 [-----][-----][-----] f(DM) 3 0 2 3 2 3 1
 [-----] f' 3 0 2 3 2 3 1
 ----- p *3 0 2 3 2 3 1
 a. 3 0 3 2 2 3 1 ST
 b.*3 0 2 3 2 3 1 ST
 'Your dog bit the bird and the bird was then wounded.'

(30) wo zhun ni ba gou gei Xiao-Ming.
 I allow you BA dog give name
 3 3 3 3 3 3 3 2 UT
 [-----][-----][-----][-----] f(DM) 2 3 2 3 2 3 3 2
 ----- p *2 3 2 3 2 2 3 2
 a. 3 2 3 2 3 2 3 2 ST
 b.*2 3 2 3 2 2 3 2 ST
 'I allow you to give the dog to Xiao-Ming.'

In (28)-(30), the NP following the preposition [ba] is not a pronoun. Thus, foot construction in (28)-(30) must be by FFR-DM, as shown in the above examples. In (28), FFR-DM and f' generates only one tone pattern (28c). In both (29) and (30), FFR-DM cannot generate any of the possible tone patterns. Instead, an incorrect ones are generated. In contrast, if FFR-IC applies first and then super-foot formation, the correct tone pattern can be derived. For instance, (29) will have the prosodic structure in (31).

(31) ni-de gou ba niao yao-shang le.
 your dog BA bird bite-wounded
 3 0 3 3 3 3 1 UT
 [-----] [-----][-----] f (IC) [30] [3] [23] [31]
 [-----] [-----] f' [3 0 3] [2 2 3 1]
 ----- p [3 0 3 2 2 3 1]
 'Your dog bit the bird and the bird was then wounded.'

In other words, the Foot Formation Rule cannot generate all the possible tone patterns. In particular, if FFR-IC does not apply to PPs with full NPs, the correct tone patterns in strings with more than four syllables (such as (28)-(30)) cannot be generated.

It should be noted that the difference between pronouns and full NPs is not restricted to PPs. Consider (32a) and (32b).

(32a) wo zhao Xiao-ming [PRO da lao-shu]
 I find hit rat
 3 3 3 2 3 2 3 UT
 2 2 3 2 3 2 3 ST
 'I asked Xiaoming to hit the rat.'

(32b) Xiao-li zhao Xiao-ming [PRO da lao-shu]
 find hit rat
 3 3 3 3 2 3 2 3 UT
 2 3 2 3 2 3 2 3 ST
 'Xiaoli asked Xiaoming to hit the rat.'

Notice that (32a) and (32b) share exactly the same syntactic structure. In (32a), the subject [wo] 'I' (a pronoun) is paired with the verb [zhao] 'find'. But in (32b), the subject [Xiaoming] (a proper noun) is not paired with the verb [zhao] 'find'. Instead, [zhao] is paired with [Xiaoming] (the object). Thus, the pronoun-noun distinction must be stated as a more general constraint on the formation of prosodic structures rather than restricted to PPs.

Furthermore, Shih has to resort to the lexical integrity principle to handle sentences such as (33) and (34).

(33) wo xiang [PRO qi-lai le]
 I think up-come
 3 3 3 2 UT
 2 2 3 2 ST
 'I want to get up.'

(34) wo [xiang-[qi-lai]] le.
 I think up-come
 3 3 3 3 UT
 3 2 3 2 ST
 'I remembered.'

The lexical integrity principle states that no rule can refer to the internal structure of lexical items. Thus, "lexical information cannot be destroyed, or altered, through post-lexical processes." (Shih 1985, p.136)

Shih (1985) states that the Foot Formation Rule stated in (17) can alter the syntactic structure. Yet, if a lexical category (word or compound) is involved, such an alternation cannot take place. Note that although (33) and (34) have the same lexical items, in (34), [xiang qi lai] is a compound. According to Shih's Foot Formation Rule, (33) and (34) have the following prosodic structures:

(35a) wo xiang [PRO qi-lai le]
 I think up come 3 3 3 2 UT
 [-----] f(IC)- - 3 2
 [-----] f(DM)2 3 - -
 ----- p 2 2 3 2 ST
 'I want to get up.'

(35b) wo [xiang [qi-lai]] le.
 I think up come 3 3 3 2 UT
 [-----] f(IC)- - 3 2
 [-----] f(DM)2 3 - -
 ----- p *2 2 3 2 ST
 'I remembered.'

The tone pattern derived from the prosodic structure (35b) is identical to the tone pattern in (33) (and therefore incorrect for (34)). To throw out this sentence, the lexical integrity condition needs to "look back" to the lexical structure. In other words, the mechanisms involved are quite global.

In short, although Shih's model accounts for the discrepancies between syntactic structures and the actual tonal patterns, it does not account for all the possible readings. Further, by resorting to the lexical integrity principle to account for sentences such as (34), her model is weakened.

4. A New Proposal

From the above discussion, it is clear that a direct mapping from syntax onto phonology does not give the right predictions. And Shih's particular mapping (1985) does not seem to generate the correct tone patterns either. In the following discussion, I propose a model that makes use of syntactic constituency and the lexical phonology model. My proposal is based on Hayes' (1984) framework which is briefly described below.

4.1. Hayes' (1984) Prosodic Hierarchy

Hayes proposes that phonological rules of the phrasal level apply not directly to syntactic structures but to prosodic structures derived from syntactic structures. The prosodic hierarchy he proposes is: word, clitic group, phonological phrase, intonational phrase and utterance. Hayes assumes that word level phonology takes place in the lexicon, as proposed in the lexical phonology model (Kiparsky 1982). The clitic group differentiates between content words (i.e.

full NPs) and function words (i.e. prepositions, pronouns, and determiners). Basically, content words can form individual clitic groups while function words must be incorporated into adjacent clitic groups. Since the particular rule of cliticization mentioned in his paper is said to be language-specific, I will not discuss the details here. In general, the clitic group serves as a bridge between words and phonological phrases.

The next levels in the hierarchy are the phonological phrase (PPh) and the intonational phrase (IPh). The formation of PPh's and IPh's is associated with language-specific parameters. In general, as Hayes indicates, "PPh formation obligatorily adjoins all materials on the non-recursive side and varies only in whether an adjacent complement is adjoined on the recursive side." (p.12)⁴

4.2. The Prosodic Hierarchy in Mandarin

In this section, I will argue that variations of tone patterns can be accounted for by the prosodic hierarchy proposed in Hayes (1984). I will present evidence from compounds and reduplicated forms in Mandarin to show that 3TS can apply in the lexicon as the lexical phonology framework predicts. Given the strict cycle condition, which blocks access to word internal structure in postlexical rules, the internal structure of compounds and reduplicated forms is not available at the sentential level. In 4.2.2, I will discuss the prosodic hierarchy in Mandarin.

4.2.1. 3TS in the Lexicon

Hayes (1984) assumes that phonological rules apply in the lexicon as in the model of lexical phonology. In this section, I will examine 3TS in relation to the lexical phonology model. The lexical phonology model predicts that compounds or reduplicated forms (if forming a tone sandhi pair) will obligatorily enter the 3TS domain at the lexical level.

A. Compounding

According to the lexical phonology model, rules in the lexicon can be cyclic. Consider the following compounds:

(36)	gui-lian	'ghost-face'
	3 3	UT
	2 3	ST

(37) dan-xiao 'gall-small=cowardly'
 3 3 UT
 2 3 ST

(38)a. zu-zhang
 3 3 UT
 'group-chief=chief of a department'

b. zong [zu-zhang] 'general chief'
 3 3 3 UT
 3 2 3 ST

(39)a. zhan-lan 'exhibit-see=exhibit'
 3 3 UT

b. [[zhan-lan] chang]
 exhibit place
 3 3 3 UT
 2 2 3 ST
 'exhibition place'

(40)a. xuan-ju 'elect-nominate=elect'
 3 3 UT

b. [[xuan-ju] fa]
 elect law
 3 3 3 UT
 2 2 3 ST
 'election law'

Take (38b) as an example, if 3TS applies cyclically, correct surface tones can be generated, as shown in (41).5

(41)	[zong],[zu],[zhang]	individual lexical entries
	3 3 3	
	[[zu][zhang]]	compounding
	3 3	
	2 3	3TS
	[[zong][[zu][zhang]]]	compounding
	3 2 3	
	-----	3TS
	[zong-zu-zhang]	output
	3 2 3	

B. Reduplication

With reduplicated forms, 3TS also applies cyclically. Consider (42)-(45). (See Li and Thompson (1981) for more examples on different types of compounds.)

(42)	zou-zou		'to walk a little'
	walk-walk		
	3 3		UT
	2 3		ST

(43)a.	[chu-li]		'to handle'
	handle-arrange		
	3 3		UT
	2 3		ST

b.	[chu-li][chu-li]		
	handle handle		
	3 3 3 3		UT
	2 3 2 3		ST
	'to handle something a little'		

(44)a.	gui-ju		'well-behaved'
	1 3		UT and ST

b.	[gui-gui][ju-ju]		'well-behaved'
	1 1 3 3		UT
	1 1 2 3		ST

(45)a.	mian qiang		'reluctant'
	3 3		UT

b.	[mian-mian] [qiang-qiang]		
	3 3 3 3		UT
	2 3 2 3		ST

If 3TS applies cyclically, the correct surface tones can be generated. Hence, it appears that 3TS applies cyclically in the lexicon and that all lexical tone sandhi pairs have undergone 3TS when the lexical items are inserted in the syntactic structures.

4.2.2. 3TS and Prosodic Hierarchy

In Section 4.2.1, I showed that 3TS applies in the lexicon. The main issue of concern now is the application of 3TS at the sentential level. From the discussion in Section 3, it is clear that various tone patterns for a single sentence present problems for either pure syntactic models or for Shih's prosodic model (1985). I will examine these problematic data within Hayes' framework.

Following Hayes (1984), I will discuss four levels of prosodic structure, word (W), clitic group (CG), phonological phrase (PPh) and intonational phrase (IPh). 3TS applies within each level.

A. Word

This is the lowest level in the hierarchy. I assume that besides individual lexical items (in Mandarin, one syllable equals one lexical item), anything that is derived through a morphological process is a word. Therefore, compounds and reduplicated forms are considered 'words'. Beyond the word level, the internal structure of a word is not available (i.e. bracket erasure convention).

B. Clitic Group (CG)

The clitic group is the level between word and PPh. In Mandarin, the formation of the CG is sensitive to the distinction between content words (nouns and verbs) and function words (pronouns, prepositions and determiners). The formation of a CG observes syntactic constituency. The CG in Mandarin is formed as outlined below:

(46) Clitic Group Formation (CGF):

- i) every content word needs a separate clitic group.
- ii) each clitic group incorporates adjacent function words based on syntactic constituency. The incorporation of function words does not cross a sentential boundary. Once the directionality is established based on syntactic constituency, the incorporation of function words in the opposite direction is not permitted.

In (47), X1, X2 and X3 are function words (fw). All three function words to the left of the clitic group are incorporated into the clitic group (under CFG-ii).

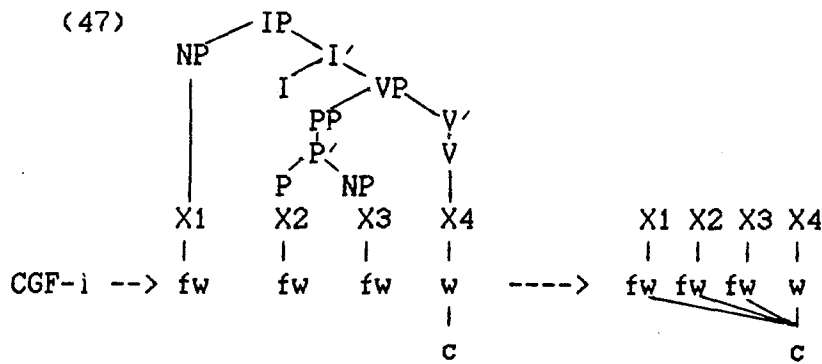

In (48), X1, X3, X4 and X5 are fw's.

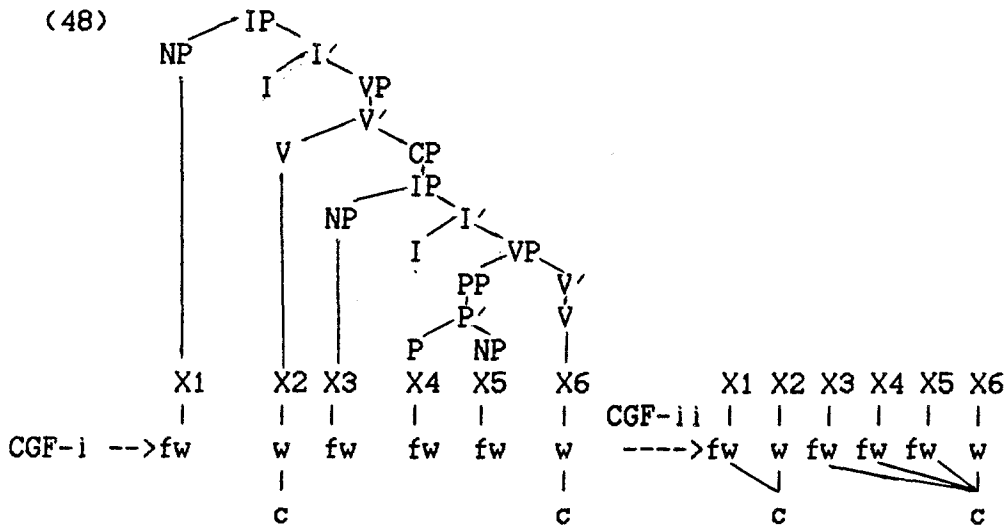

In (49), X1 and X3 are function words.

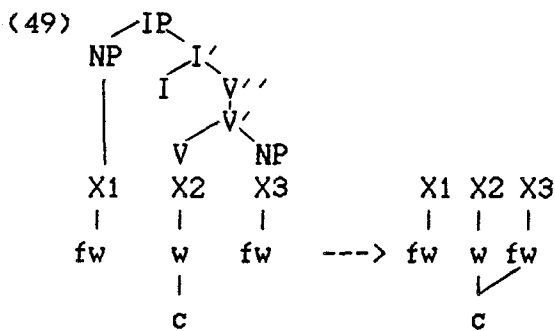

Note that in (49), X3 and X2 are under V''. Based on syntactic constituency, X3 must be incorporated into the clitic group first. As the direction of incorporation is to the right, X1 cannot be incorporated in the clitic group as required by (46-ii).

C. Phonological Phrase (PPh) and Intonational Phrase (IPh)

One or more clitic groups are adjoined to form a PPh. The formation of PPh's respects sentence boundaries and there can be sublevels in PPh's. Consider example (49). The left-over function word, X1 and the clitic group form one PPh as shown below.

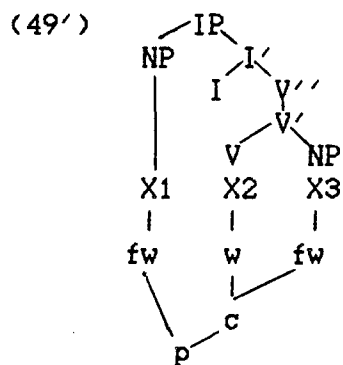

Now consider sentence (50).

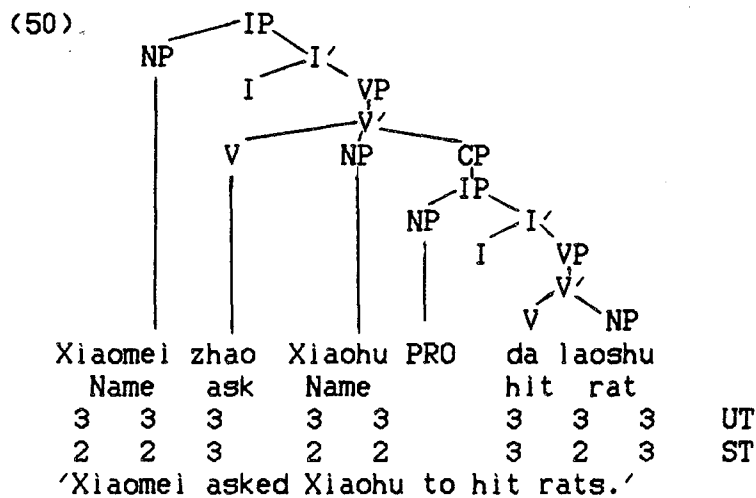

In (50), 'Xiaomei', 'Xiaohu' and 'laoshu' are all compound nouns. At the word level, 3TS applies to these compound nouns and the entries at the sentential level have the tones [2 3] for these three compounds. Since there are no function words in (50), all the words in this sentence form separate clitic groups, as shown in (51).

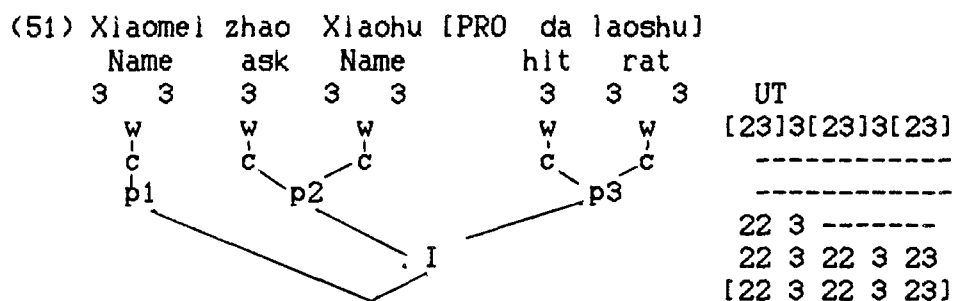

Based on the syntactic constituency of (50), p2 adjoins the VP [zhao Xiaohu] 'find/ask Xiaohu', and p3 adjoins the VP [da laoshu] 'hit rat'. 'Xiaomei' itself constitutes a single PPh (p1). P1 and p2 can be adjoined together to form a higher level of phonological phrases, and with p3 they form an IPh. Following Selkirk (1984), I assume that phrasal phonological rules apply within intonational phrases but not across them. Thus, 3TS applies within the IPh in (51).

Given the prosodic structures outlined above, let us examine the problematic data in Shih (1985). Centences (20)-(23) are repeated here for convenience. (Tone pattern (c) in the following sentences will be discussed in 4.2.3.)

- (52) ni bi wo xiao
 you compare I small
 3 3 3 3 UT
 a. 2 2 2 3 ST
 b. 3 2 2 3 ST
 c.*2 3 2 3 ST
 'You are smaller than I am.'

- (53) ni ba gou da le.
 you BA dog hit-ASP
 3 3 3 3 UT
 a. 3 2 2 3 ST
 b. 2 2 2 3 ST
 c. 2 3 2 3 ST
 'You hit the dog.'

- (54) gou bi ni xiao.
 dog compare you small
 3 3 3 3 UT
 a. 3 2 2 3 ST
 b.?2 2 2 3 ST
 c.*2 3 2 3 ST
 'The dog is smaller than you are.'

(55)	gou	ba	niao	yao	le.	
	dog	BA	bird	bite		
	3	3	3	3		UT
a.	3	2	2	3		ST
b.?	2	2	2	3		ST
c.	2	3	2	3		ST

'The dog bit the bird.'

(52a) is predicted by this model directly. (56) shows the prosodic structure of the sentence.

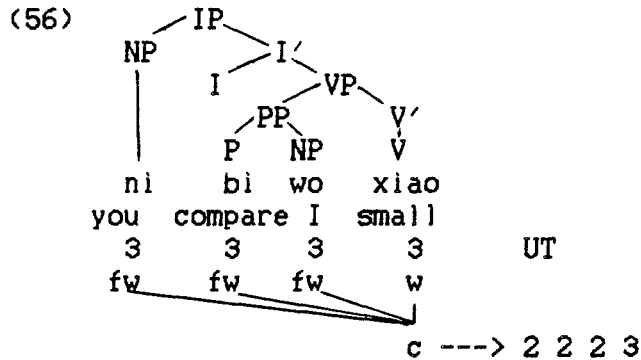

There is only one content word in (56), namely the verb [xiao] 'small'. Thus, according to the CGF-ii stated in (46), the content word [xiao] 'small' can incorporate all the function words in the sentence.

When the tone pattern in (52b) is used, there is a particular emphasis on the word [ni] 'you'. Thus, I assume that this represents a topicalized structure where one element or one phrase is put into focus in the sentence. As Huang (1984) states, topicalized elements are moved outside of IP. Thus, when 'ni' (you) in (52) is topicalized, the structure is of the form in (57).

(57)	ni,	ip[e	bi	wo	xiao]
	you		compare	I	small	

(e is the trace of the topicalized [ni].)

Further, I assume that the element outside of IP forms an individual IPh. Thus, (57) has the following prosodic structure:

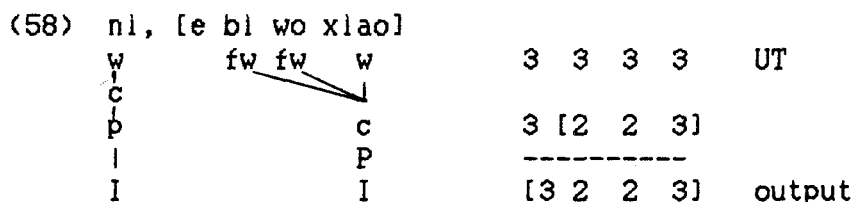

Notice that since the topicalized element cannot be incorporated into other content words to form a clitic group, it forms a separate clitic group, a PPh and an IPh by itself. As for the elements inside S, the structure is similar to the one in (57). As there are two IPh's in (58), 3TS does not apply across the IPhs boundaries and the surface tone pattern is [3 2 2 3]. Hence, from the prosodic hierarchy and the topicalization structure, both of the correct readings in (52) can be generated.

Now consider (53) in which the prepositional phrase takes a noun instead of a pronoun. According to the Clitic Group Formation rule stated above, [gou] 'dog' in (53) forms its own clitic group. Thus, the prosodic structure for (53) is (59).

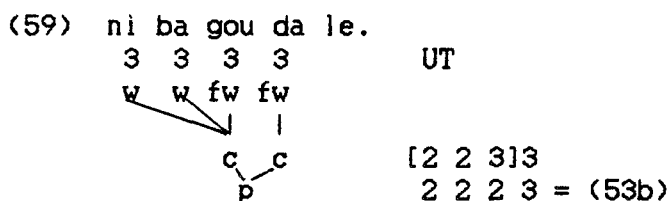

Similarly, with topicalization, (53a) can be derived.

(54a) and (55a) can be derived either with or without a topicalized structure. Notice that (54) is the only sentence that allows one and only one tone pattern. Consider the prosodic structure (60) for (54).

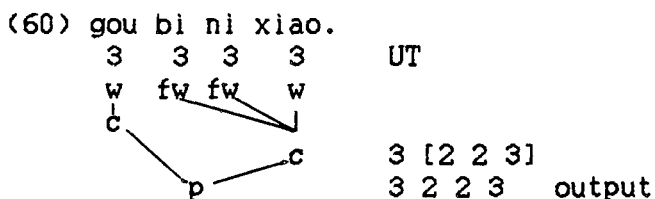

Even if [gou] 'dog' is topicalized, the same tone pattern will be derived. As for (55), it should be noted that (55b) is possible although unnatural. The unnaturalness of the tone pattern is attributed to the fact that nouns in Mandarin require modifiers (either adjectives, determiners, or quantifiers) except in PPs. Both (54) and (55) have the same unnaturalness because of this. Given the

unnatural NP, speakers of Mandarin are able to treat them as function words rather than content words. In consequence, (56) and (57) can have the same tone pattern as that of (54a) or (55b). Therefore, it appears that the formation of prosodic structure outlined in (46) and the topicalized structure can predict different tone patterns in sentences.

4.2.3. Marked Clitic Group Formation

In Shih (1985), the tone patterns (a) and (b) in (52)-(55) are presented. Yet, she does not mention how her Foot-Formation rule or super-foot formation rule can account for them. Instead, she concentrates on the tone patterns in (c), leading her to posit FFR-DM for PPs with content words. As pointed out in Section 3, FFR-DM does not consistently derive the correct tone patterns. In this section, based on (55c) to (58c), I propose a rule of Marked Clitic Group Formation which can be stated as follows:

(61) Marked Clitic Group Formation

When there are two or more adjacent function words, scanning from left to right, they can form clitic groups on their own. Left over function words are incorporated into an adjacent clitic group based on syntactic constituency.

In sentences (52) and (54), Marked Clitic Group Formation will not produce pattern (c) because [wo] 'I' and [ni] 'you' in the prepositional phrase branch to the left, as shown in (62). On the other hand, since the objects of the preposition, [gou] 'dog' and [niao] 'bird' in (53) and (55) are content words, they form their own clitic group. Then the clitic group is adjoined to the head resulting in (53c) and (55c), as shown in (62) and (64).

(62a)=(52)

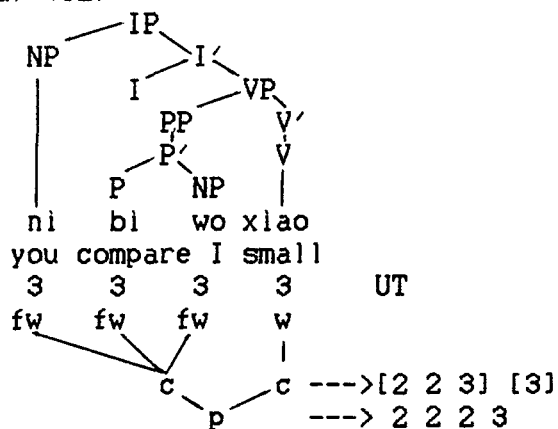

(62b)=(54)

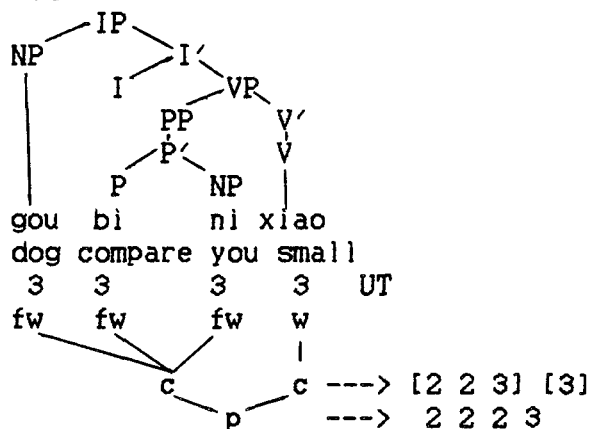

(63)

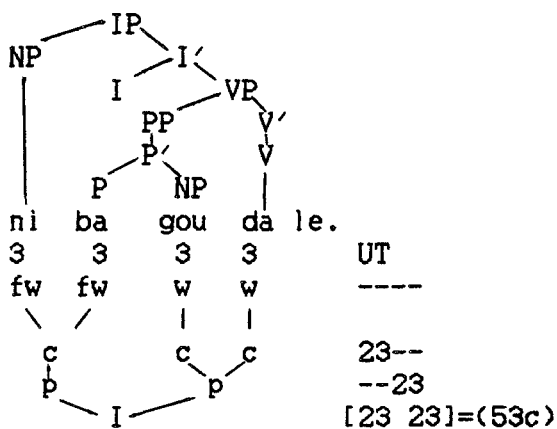

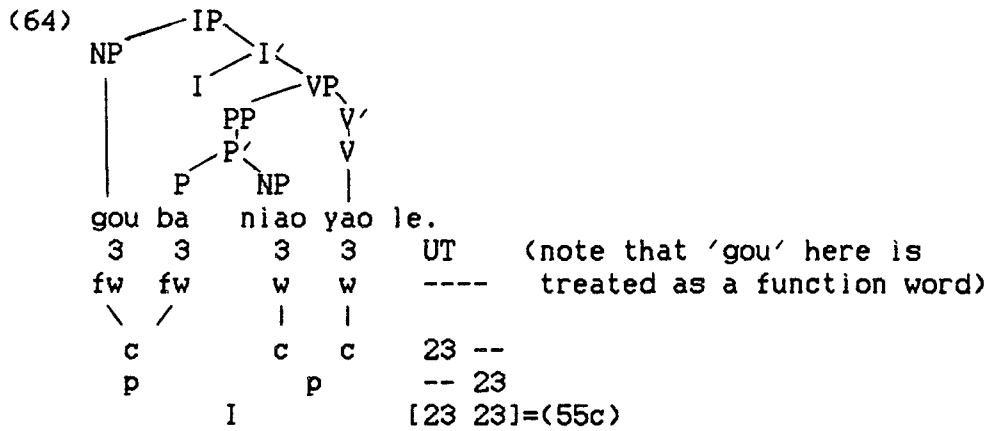

Notice that given Marked Clitic Group Formation, the Marked Clitic Group will be forced to form a PPh on its own. Consider the structure of the form:

(65) [ni] [[ba gou] da]

After 'ni' and 'ba' form a clitic group, 'gou' and 'da' will form a PPh because 'da' (the verb) is the head of V''. It then follows that [ni ba] will form a PPh.

This clitic group formation is marked because the tone pattern that it derives is not the most natural one. It is certainly not the one that native speakers of the language would voluntarily utter. In most circumstances, this particular tone pattern must be pointed out to native speakers. Shih's (1985) FFR-DM is derived from Chen's (1979) phrasing rules developed for the purpose of poetic scansion. As discussed in Section 3, FFR-DM is used to account for the (c) tone pattern. The marked clitic group in this section serves the same purpose. That is, tones are grouped to form duple meter. Since this is not the natural tone pattern, I assume that people accept it by treating it as a poetic line. This is supported by revising the sentences above. Consider (66) and (67).

(66) ni ba gou da shang le.
 you BA dog hit wounded
 3 3 3 3 1 UT
 a. 2 2 2 3 1 ST
 b. 3 2 2 3 1 ST
 c. *2 3 2 3 1 ST
 ' You hit the dog and the dog was wounded.'

(67) ni-de gou ba niao yao shang le.
 your dog BA bird bite wounded

	3	0	3	3	3	3	1		UT
a.	3	0	3	2	2	3	1		ST
b.*	3	0	2	2	2	3	1		ST
c.*	3	0	2	3	2	3	1		ST

'Your dog bit the bird and it was wounded.'

In both (66) and (67) the tone pattern [2 3 2 3] for the four relevant words is impossible because both (66) and (67) are perfectly well-formed syntactic structures.

Besides the PPs with full NPs, Shih (1985) points out an additional exception to her analysis, classifiers in quantifier phrases. Consider (68) and (69).

(68)

	wo	mai	ba	san	
	I	buy	CL	umbrella	
	3	3	3	3	UT
a.	3	2	2	3	ST
b.*	2	3	2	3	ST
c.*	2	2	2	3	ST

'I brought an umbrella.'

(69) mai dian jiu
 buy CL wine

	3	3	3		UT
	2	2	2		ST

'buy a little wine'

Shih (1985) suggests that a 'classifier cliticization' results in this tone pattern. The classifier cliticization can be represented in (70).

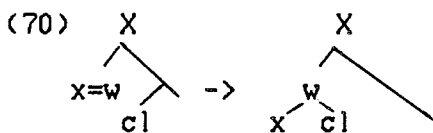

In other words, the classifier is cliticized onto the preceding verb and they together form a word. Under my analysis, the cliticization can still take place. Classifiers, as determiners, are treated as function words. Therefore, I assume that classifiers are always "cliticized"

onto the clitic group on their left instead of observing syntactic constituency. Moreover, this cliticization happens before other function words are incorporated. Hence, (68) has the following prosodic structure:

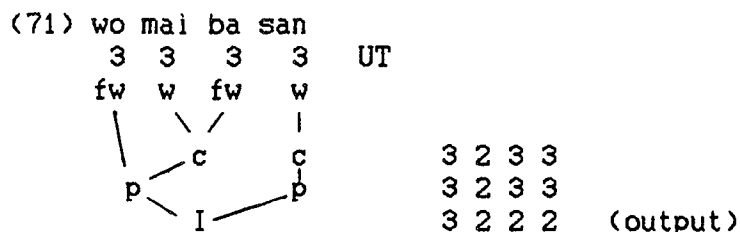

Although the classifier cliticization rule needs to be stipulated, it is readily incorporated into the model of prosodic hierarchy.

5. Conclusion

This paper shows that phonological rules such as 3TS do not apply strictly to syntactic structures. Instead, a prosodic structure which is built from a syntactic structure appears to introduce the correct domains. Although Shih (1985) proposes a prosodic structure approach, her model does not allow the flexibility required to generate several readings for a single sentence.

In the proposal stated in Section 4, 3TS applies at both the lexical level and the post-lexical level. Tone sandhi pairs which are compounds or reduplicated forms are taken care of by 3TS at the lexical level. At the postlexical level, prosodic structures which are derived from syntactic structures serve as the domain of application for 3TS. The prosodic structures are built according to the prosodic hierarchy constraints in Mandarin.

The variations of tone patterns are accounted for by the Marked Clitic Group Formation (63) and the topicalization structure in Mandarin. As stated in Section 4, the interpretation implied from each reading is predicted by the prosodic structure. In sum, the prosodic hierarchy proposed in Section 4 appears to account for all the data and all the possible readings. With regard to tempo, more data are needed in order to determine the role of tempo in Mandarin third tone sandhi.

FOOTNOTES

1. In this paper, I assume the X-bar schema in Chomsky (1986). It holds for both lexical and non-lexical categories. All maximal categories are projections of their zero-level categories. COMP is therefore the head of S', now the complementizer phrase (C'') and INFL is the head of S, the INFL phrase (I'').
2. Ba is called a 'coverb' in traditional terms. Cheng (1986) argues that ba is in fact a preposition.
3. It should be noted that empty nodes (CP) and the empty category are not being considered here since they are phonological null. Thus, after the cycle for the VP [yang xiao ma] 'raise a little pony', the next cycle is the VP [xiang yang xiao ma] 'want to raise a little pony'.
4. The recursive side of X'' is the side of X'' on which complements freely occur.
5. See L. Cheng (1985) concerning arguments for a cyclic approach.
6. Note that this sentence is said slowly and both 'Xiaomei' and 'Xiaohu' are being emphasized.

REFERENCES

- Chen, M. (1979) "Metrical Structure: Evidence from Chinese Poetry." Linguistic Inquiry, 10:3, 371-420.
- Cheng, Chin-Chuan (1973) A Synchronic Phonology of Mandarin Chinese, Mouton. The Hague.
- Cheng, L. (1985) Mandarin Chinese Tone Sandhi and Lexical Phonology. ms.
- Cheng, L. (1986) Clause structures in Mandarin Chinese. ms.
- Chomsky, N. (1986) Barriers. MIT Press.
- Hayes, B. (1984) The Prosodic Hierarchy in Meter. ms.
- Huang, C-T. J. (1984) "On the Distribution and Reference of Empty Pronouns." Linguistic Inquiry, 15:4:531-574.
- Kaisse, E.M. (1985) Connected Speech: the Interaction of Syntax and Phonology. Academic Press.
- Kiparsky, P. (1982) "From Cyclic Phonology to Lexical Phonology." In Van de Hulst, H. and N. Smith (eds.) The Structure of Phonological Representation. Part 1, Foris Publication.
- Li, C. and S. Thompson (1981) Mandarin Chinese: A Reference Grammar.
- Selkirk, E.O. (1984) Phonology and Syntax: The Relation between Sound and Structure. MIT Press.
- Shih, Chi-Lin (1985) The Prosodic Domain of Tone Sandhi in Chinese. UCSD Dissertation.