

VU Research Portal

Take It or Leave It

Ullah, Nimat; Koole, Sander L.; Treur, Jan

published in

Intelligent Computing Theories and Application
2020

DOI (link to publisher)

[10.1007/978-3-030-60802-6_16](https://doi.org/10.1007/978-3-030-60802-6_16)

document version

Publisher's PDF, also known as Version of record

document license

Article 25fa Dutch Copyright Act

[Link to publication in VU Research Portal](#)

citation for published version (APA)

Ullah, N., Koole, S. L., & Treur, J. (2020). Take It or Leave It: A Computational Model for Flexibility in Decision-Making in Downregulating Negative Emotions. In D-S. Huang, & K-H. Jo (Eds.), *Intelligent Computing Theories and Application: 16th International Conference, ICIC 2020, Bari, Italy, October 2–5, 2020, Proceedings - Part II* (Vol. 2, pp. 175-187). (Lecture Notes in Computer Science (including subseries Lecture Notes in Artificial Intelligence and Lecture Notes in Bioinformatics); Vol. 12464 LNCS). Springer Science and Business Media Deutschland GmbH. https://doi.org/10.1007/978-3-030-60802-6_16

General rights

Copyright and moral rights for the publications made accessible in the public portal are retained by the authors and/or other copyright owners and it is a condition of accessing publications that users recognise and abide by the legal requirements associated with these rights.

- Users may download and print one copy of any publication from the public portal for the purpose of private study or research.
- You may not further distribute the material or use it for any profit-making activity or commercial gain
- You may freely distribute the URL identifying the publication in the public portal ?

Take down policy

If you believe that this document breaches copyright please contact us providing details, and we will remove access to the work immediately and investigate your claim.

E-mail address:

vuresearchportal.ub@vu.nl



Take It or Leave It:

A Computational Model for Flexibility in Decision-Making in Downregulating Negative Emotions

Nimat Ullah¹ , Sander L. Koole², and Jan Treur¹ 

¹ Social AI Group, Department of Computer Science, Vrije Universiteit Amsterdam, Amsterdam, The Netherlands
nimatullah09@gmail.com, j.treur@vu.nl

² Amsterdam Emotion Regulation Lab, Department of Clinical Psychology, Vrije Universiteit Amsterdam, Amsterdam, The Netherlands
s.l.koole@vu.nl

Abstract. Flexibility in emotion regulation strategies is one of the properties associated to healthy minds. Emotion regulation strategies are context dependent and the adaptivity of those strategies is solely subjected to the context. Flexibility, therefore, plays a key role in the use of these emotion regulation strategies. The computational model presented in this paper, models flexibility in emotion regulation strategies that are dependent on context. Simulation results of the model are presented which provides insight of four emotion regulation strategies and highlights the role of context which activates them respectively.

Keywords: Emotion regulation · Strategies · Context · Flexibility · Adaptivity · Psychopathology

1 Introduction

Imagine that you are an office worker who gets upset when your colleague criticizes you unfairly. You can choose to walk away, distract yourself with chores, hide your negative reaction, or mentally distance yourself from your colleague. What would you do? Which of these strategies is optimal, depends on the situation. For instance, if your colleague is from a different department, you may find it easy to walk away. However, if the colleague is your boss, walking away may not be of the question, so you may be forced to distract yourself with chores. This simple example illustrates how different emotion-regulation strategies tend to yield different outcomes in different situations [1]. It thus follows that people should be able to choose flexibly between different emotion-regulation strategies in the face of different situational demands. The latter capacity is known as emotion regulation flexibility [2, 3].

Within the area of emotion regulation which is our long-term research focus, we recently proposed a computational model of emotion regulation flexibility which models a person who can switch between two strategies- expressive suppression and attention modulation - in managing anger in different work situations [4]. Building on and extending this work, the present model is inspired by the vast body of literature on

flexibility in emotion regulation strategies and, therefore, addresses the challenge to design a computational model of emotion regulation flexibility in which a person can switch between four different emotion-regulation strategies: situation modification, attention modulation, expressive suppression, and cognitive reappraisal.

In what follows, in Sect. 2, we discuss the theoretical background of our work, which is grounded in the psychological literature on emotion regulation [5–7]. Next, in Sect. 3, we present the computational model. In Sect. 4, we present the results of simulations of the model using four different scenarios. Finally, in Sect. 5, we review the main conclusions and implications of the present work.

2 Background

Emotion regulation has been defined as the set of processes whereby people control and redirect the spontaneous flow of their emotions [8]. A large body of research has implicated difficulties in emotion regulation as a transdiagnostic factor that is central to the development and maintenance of psychopathology [9, 10]. Accordingly, clinical psychologists are increasingly moving toward unified treatments that target emotion regulation for individuals with multiple disorders [11]. In addition, emotion regulation is seen as a vital positive contributor to psychological health and wellbeing [12].

The influential process model of emotion regulation [13–15] has distinguished five families of emotion regulation strategies. The first family of strategies is situation selection, and consists of taking steps to influence which situation one will be exposed to. The second family of strategies is situation modification, and consists of changing one or more relevant aspects of the situation. The third family of strategies is attentional deployment, and consists of influencing which portions of the situation are attended to. The fourth family of strategies is cognitive change, and consists of altering the way the situation is cognitively represented. Finally, the fifth family of strategies is response modulation, and consists of directly modifying emotion-related actions.

Originally, the process model [14, 16] proposed that some emotion-regulation strategies are inherently more effective than other emotion-regulation strategies. The main evidence for this notion came from studies showing that cognitive reappraisal—a prototypical cognitive change strategy—is less effortful and more effective than emotional suppression—a prototypical response modulation strategy [16]. Subsequent research, however, has shown that the effectiveness of emotion-regulation strategies is highly dependent on situational context. For instance, there are situations in which cognitive reappraisal is ineffective, or may even backfire [17–19]. Conversely, expressive suppression may be less problematic when this strategy can be flexibly applied [20].

Evidence for context-dependent effects of emotion-regulation strategies has inspired a new generation of theories that emphasize emotion regulation flexibility [1, 3, 7, 15, 21]. Although these theories differ in their particulars, they converge on the notion that, in healthy emotion regulation, strategies have to be adjusted to the demands of the situation. Consequently, emotion regulation flexibility is key to successful emotion regulation.

Empirical research on emotion regulation flexibility has so far been limited. The available research to date has focused on switching between two strategies. This two-strategy approach is presumably derived from the limitations of experimentally examining alternations between a greater number of emotion regulation strategies. For instance, Sheppes and colleagues [22] have studied the choice between distraction (an attentional deployment strategy) and reappraisal (a cognitive change strategy). Likewise, Bonanno and colleagues have operationalized emotion-regulatory flexibility as the ability to both up-regulate and down-regulate negative emotion [23].

In line with the two-strategy approach, we recently proposed a computational model of emotion regulation flexibility in which the person switches between expressive suppression and attention modulation in managing anger in different work situations [4]. Simulation results illustrated the capacity of the model to display adaptivity in emotion regulation across different contexts.

An important strength of our computational approach is that it can afford insight into the interplay between a large number of variables simultaneously, larger than it is practical to study experimentally. In the present work, we therefore sought to extend our earlier computational model to a model in which we could examine flexible, context-dependent switching between four emotion-regulation strategies.

3 The Computational Model

The computational model, presented in this paper, is hereby thoroughly elaborated. This model simulates four emotion regulation strategies as per criteria presented in Table 3. The basic concepts of the modeling approach used for this model, called Network-Oriented modeling approach, can be consulted in Table 1 from [24]. In Network-Oriented modeling approach, a phenomenon is represented in a network form consisting of nodes that varies over time. The nodes are interpreted as states and the connections between these states are interpreted as relations and it defines the impact of one state on another state over time. This type of network is, therefore, referred to as temporal-network. Conceptually, a model in temporal-network can be represented as labelled graph in which:

- Each connection carries some *connection weight* from one state to another called *impact* represent by $\omega_{x,y}$.
- There's some way to *aggregate multiple impacts* on a state (combination function $c_Y(\dots)$).
- There's a notion of *speed of change* of each state to define how faster a state changes because of the incoming impact (speed factor η_Y).

A temporal-network is defined by these three notions, see Table 1 for more explanation of the terms and for the numerical representation of the concepts.

Table 1. Basics of Network oriented modeling approach.

Concept	Conceptual Representation	Explanation
States and connections	$X, Y, X \rightarrow Y$	Describes the nodes and links of a network structure (e.g., in graphical or matrix form)
Connection weight	$\omega_{X,Y}$	The <i>connection weight</i> $\omega_{X,Y}$ usually in $[-1, 1]$ represents the strength of the causal impact of state X on state Y through connection $X \rightarrow Y$
Aggregating multiple impacts on a state	$\mathbf{c}_Y(\cdot)$	For each state Y a <i>combination function</i> $\mathbf{c}_Y(\cdot)$ is chosen to combine the causal impacts of other states on state Y
Timing of the effect of causal impact	η_Y	For each state Y a <i>speed factor</i> $\eta_Y \geq 0$ is used to represent how fast a state is changing upon causal impact
Concept	Numerical representation	Explanation
State values over time t	$Y(t)$	At each time point t each state Y in the model has a real number value, usually in $[0, 1]$
Single causal impact	$\mathbf{impact}_{X,Y}(t) = \omega_{X,Y} X(t)$	At t state X with a connection to state Y has impact on Y , using connection weight $\omega_{X,Y}$
Aggregating multiple causal impacts	$\mathbf{aggimpact}_Y(t) = \mathbf{c}_Y(\mathbf{impact}_{X_1,Y}(t), \dots, \mathbf{impact}_{X_k,Y}(t)) = \mathbf{c}_Y(\omega_{X_1,Y}X_1(t), \dots, \omega_{X_k,Y}X_k(t))$	The aggregated causal impact of multiple states X_i on Y at t , is determined using combination function $\mathbf{c}_Y(\cdot)$
Timing of the causal effect	$Y(t + \Delta t) = Y(t) + \eta_Y [\mathbf{aggimpact}_Y(t) - Y(t)] \Delta t = Y(t) + \eta_Y [\mathbf{c}_Y(\omega_{X_1,Y}X_1(t), \dots, \omega_{X_k,Y}X_k(t)) - Y(t)] \Delta t$	The causal impact on Y is exerted over time gradually, using speed factor η_Y ; here the X_i are all states with outgoing connections to state Y

For aggregation of multiple incoming impacts, Network-Oriented modeling approach provides a library of over 35 combination functions. Besides that, own-defined functions can also be added for better flexibility.

Conceptual representation of the model presented in this paper is given in Fig. 1, and the nomenclature of the states is provided in Table 2.

The model presented in Fig. 1, presents various courses of action of one person in different contexts. It switches among four different emotion regulation strategies depending on the context in which emotion has been felt and on the level of emotions felt.

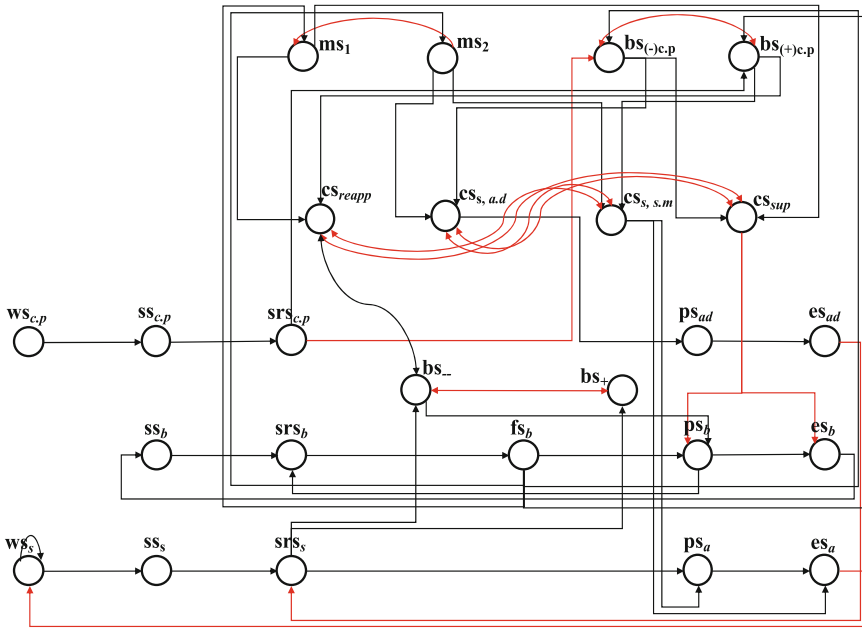

Fig. 1. Conceptual representation of the computational model as a temporal-causal network

Table 2. Nomenclature of the states of the proposed model (in connection to Fig. 1)

States	Informal Name	Description
ws_s	World state for stimulus s	The situation in the real world that triggers emotion
$ws_{c.p}$	World state for context pressure	A real-world situation which decides expression of emotion
ss_s	Sensor state for stimulus s	Sensor state for the stimulus s in the real world
$ss_{c.p}$	Sensor state for context pressure	Senses state for context pressure
ss_b	Sensor state for body	Sensor state for body
srs_s	Sensory representation state for stimulus s	Internal representation of the emotion triggering situation
$srs_{c.p}$	Sensory rep: state for context pressure	Internal representation of the context pressure in the real world
srs_b	Sensory representation state for body	Internal body representation state
bs_-	Negative believe state	The negative believe that the person has about something/someone
bs_+	Positive believe state	The positive believe that the person has about something/someone

(continued)

Table 2. (continued)

States	Informal Name	Description
ms_1	Monitoring state for low emotion level	Monitors for low emotions
ms_2	Monitoring state for high emotion level	Monitors for high emotions
$bs_{(+).c.p}$	Belief state for context pressure	Believing that expression of emotion will matter in the environment
$bs_{(-).c.p}$	Belief state for context pressure	Believing that expression of emotion won't matter in the environment
cs_{reapp}	Control state for reappraisal	Controlling negative beliefs about something/someone
$cs_{s, a.d}$	Control state for attention deployment	Control state for Attention Deployment
$cs_{s,s.m}$	Control state for situation modification	Control state for situation modification as a result of context
cs_{sup}	Control state for suppression	Control state for Suppression of Expression
fs_b	Feeling state for body state b	Feeling associated to body state b
ps_a	Preparation state for action a	Preparing for action a
ps_b	Preparation for body state b	Preparation state for body state b
ps_{ad}	Preparation state for attention deployment	Preparation for the Attention deployment action
es_a	Execution state for action a	Execution station for action a
es_b	Execution state for body state b	Execution state for body state b
es_{ad}	Execution state for attention deployment	Execution state for the Attentional Deployment action

Table 3. Choice of strategies under high/low intensity of emotions and +/- belief about context pressure

Flexibility Parameters		Repertoire of Strategies			
Emotion Strength	Context Pressure (CP)	Situation Modification	Attention Deployment	Reappraisal	Expressive Suppression
+	+	✓			
+	-		✓		
-	+			✓	
-	-				✓

The emotions can either be of high or low intensity and about the Context Pressure (CP), belief can either be positive or negative. Belief about CP refers to the person's belief about presence or absence of any environmental factor in which expression of emotion matters or doesn't matter. In other words, the belief refers to one's prediction

of such factor. Selection of each strategy is subjected to two conditions i.e. the intensity of emotion and CP. The '+' symbol represents high intensity under emotion strength and positive belief/prediction about presence of an environment/factor where expression of emotion will matter. For instance, if a person feels high intensity of negative emotions and he's expecting a factor i.e. boss etc. due to which he believes his expression of emotions can have bad consequences for him, he would prefer situation modification. There are four combinations of the primary and secondary stimulus as described in Table 1, which leads into four different emotion regulation strategies interpreted below:

1. High intensity of emotion (+) and (+) belief about CP leads to situation modification " cs_{sm} ".
2. High intensity of emotion (+) and (-) belief about CP activates attention deployment " $cs_{a.d}$ ".
3. Low intensity of emotion (-) and (+) belief about CP triggers reappraisal " cs_{reapp} ".
4. Low intensity of emotion (-) and (-) belief about CP initiates expressive suppression " cs_{sup} ".

4 Scenarios and Simulation Results

The computational model presented in this paper is loosely based on an example discussed by [2] with flexibility in emotion regulation strategies as modeled in [4] and decision making among various emotion regulation strategies as [25]. It's worth mentioning here that [25] is the only model, so far, considering decision making for three ER strategies up till now, which the current model extends to a repertoire of four strategies.

"An employee A feels angry every time a particular obnoxious coworker B starts talking. Next week the organization has monthly review meeting where presence of all the employees is mandatory unless emergency. Employee A doesn't want anyone, especially his boss to come to know about his attitude towards employee B. Employee A has four options to handle the situation, all depending upon the combination of his intensity of emotions and the chances of presences or absence of their boss in the meeting as shown in Table 3."

The parameter values given in Tables 4 and 5, in the absence of availability of quantitative data, qualitatively validates the proposed model against the findings from social sciences and psychology that serve as qualitative evaluation indicators. These parameter values make the model reproducible; they give the simulation results as shown in Figs. 2, 3, 4 and 5. In Table 4 each state can either have value of scaling factor (λ) for which scale sum function has been used or it can have values for steepness (σ) and threshold (τ) for which alogistic combination function has been used.

Table 4. Values used for alogistic, scaled-sum combination functions and speed factor

State	λ	τ	σ	η	State	τ	σ	η
ws_s	0.94	0	0	0.1	ms_2	0.5	50	0.5
ss_s	0	0	0	0.5	$bs_{(-)c.p}$	0.1	50	0.5
ss_b	0	0	0	0.5	$bs_{(+)c.p}$	0.5	17	0.5
srs_s	1	0	0	0.5	cs_{reapp}	0.5	8	0.15
srs_b	1.4	0	0	0.5	$cs_{a.d}$	0.85	12	0.2
bs_-	0.91	0	0	0.5	$cs_{s.m}$	0.85	12	0.3
bs_+	0	0.1	10	0.5	cs_{sup}	0.5	6	0.15
ps_b	1.8	0	0	0.5	ps_a	0.6	5	0.5
es_b	0.98	0	0	0.5	$ps_{a.d}$	0	0	0.3
fs_b	1	0	0	0.5	es_a	0.5	3	0.5
ms_l	0	0.1	5	0.5	$es_{a.d}$	0	0	0.3

Table 5. Values used for connection weights

Connection	Weight	Connection	Weight	Connection	Weight	Connection	Weight
$\omega_{wss, wss}$	0.95	$\omega_{bs+, bs-}$	-0.4	$\omega_{csreapp, css.m}$	-1	$\omega_{fsb, ms1}$	0.5
$\omega_{wss, sss}$	1	$\omega_{ms1, csreapp}$	0.2	$\omega_{csreapp, cssup}$	-1	$\omega_{fsb, ms2}$	0.8
$\omega_{sss, srs}$	1	$\omega_{ms1, cssup}$	0.4	$\omega_{csa.d, psa.d}$	1	$\omega_{fsb, bs(-)c.p}$	0.5
$\omega_{ssb, srsb}$	0.7	$\omega_{ms2, ms1}$	-1	$\omega_{csa.d, css.m}$	-1	$\omega_{fsb, bs(+)c.p}$	0.5
$\omega_{srs, bsc-}$	0.9	$\omega_{ms2, csa.d}$	0.35	$\omega_{csa.d, cssup}$	-1	$\omega_{fsb, psb}$	0.9
$\omega_{srs, bsc+}$	0.4	$\omega_{ms2, css.m}$	0.5	$\omega_{css.m, psa}$	0.8	$\omega_{psa, esa}$	0.5
$\omega_{srs, psa}$	0.3	$\omega_{bs(-)c.p, bs(+)c.p}$	-1	$\omega_{css.m, esa}$	0.8	$\omega_{psb, srsb}$	0.75
$\omega_{srsc.p, bs(-)c.p}$	-1	$\omega_{bs(-)c.p, cssup}$	0.3	$\omega_{css.m, csreapp}$	-1	$\omega_{psb, esb}$	1
$\omega_{srsc.p, bs(+)c.p}$	1	$\omega_{bs(-)c.p, csa.d}$	0.6	$\omega_{css.m, csa.d}$	-1	$\omega_{psa.d, esa.d}$	1
$\omega_{srsb, fsb}$	1	$\omega_{bs(+)c.p, bs(-)c.p}$	-1	$\omega_{cssup, psb}$	-1	$\omega_{esa, wss}$	-0.5
$\omega_{bs-, bs+}$	-0.4	$\omega_{bs(+)c.p, css.m}$	0.5	$\omega_{cssup, esb}$	-0.2	$\omega_{esb, ssb}$	1
$\omega_{bs-, csreapp}$	0.05	$\omega_{bs(+)c.p, csreapp}$	0.33	$\omega_{cssup, csreapp}$	-1	$\omega_{esa.d, srs}$	0.63
$\omega_{bs-, psb}$	1	$\omega_{csreapp, bs-}$	-0.35	$\omega_{cssup, csa.d}$	-1		

All the simulation results, given below, only have the most essential states for the explanation of the results.

Figure 2 depicts a context with low intensity of emotions and positive belief about CP. This means that the person knows that his emotional expression will have consequences for him and the intensity of negative emotions that he/she is feeling is of moderate/low level. So, as the person already anticipates presence of the CP, therefore, he’s reappraising his belief about the stimuli. In the figure, it can be seen that initially negative belief bs_- is quite high but it decreases as control state for reappraisal cs_{reapp} gets activated. As a result, the positive belief bs_+ increases and the feeling state fs_b also gets lower as the negative belief gets weaker and the positive belief gets stronger.

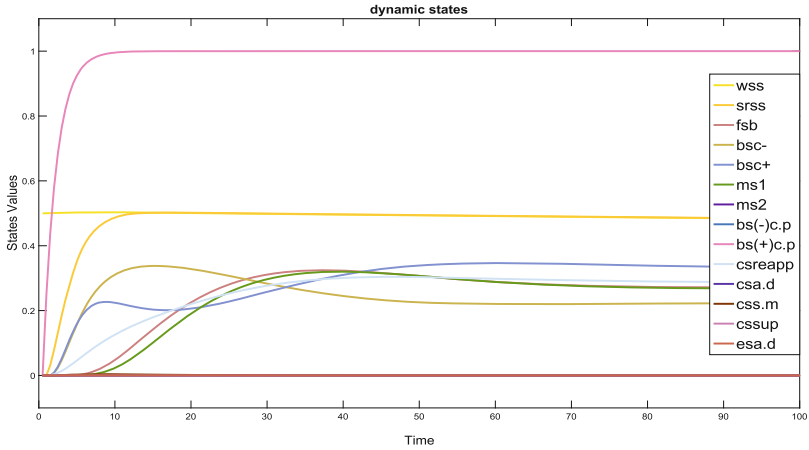

Fig. 2. Cognitive Reappraisal: low intensity of emotions and positive belief/prediction about the context pressure

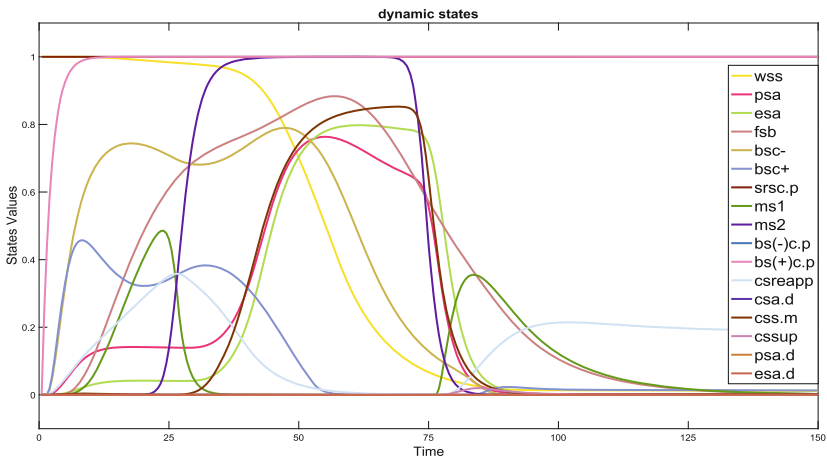

Fig. 3. Situation Modification: as a result of high intensity of emotions and positive belief/prediction about the context pressure

Figure 3 depicts the activation of situation modification as a strategy, which gets activated when the person is feeling high intensity of emotions while having positive belief about the CP (i.e. he is predicting an environment where he can't afford if his emotions are observed). In the figure it can be seen that initially control state for reappraisal cs_{reapp} gets activated. It's because the person tries to reappraise initially when the intensity of his emotions is not yet high. Later on, as the intensity of negative emotions increases, control state for situation modification $cs_{s,m}$ gets activated. As situation modification means that the person is leaving/changing the situation, therefore, the world state ws_s , where the emotional event is/will take place, gets decreased as

soon as preparation state for action ‘a’ ps_a and execution state for action ‘a’ es_a gets increasing, representing some physical action in the real world. As a result, the execution of action decreases the intensity of (negative) feelings fs_b .

Similarly, once again when the intensity of emotions is low enough after leaving/changing the situation, control state for reappraisal cs_{reapp} gets activated. The result is as expected.

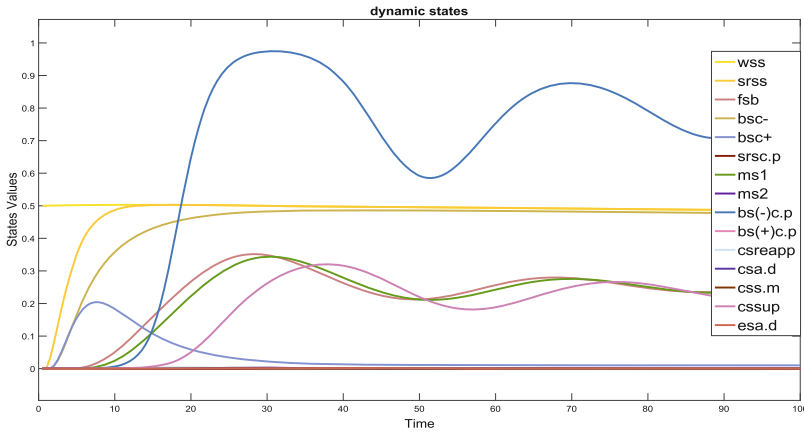

Fig. 4. Expressive Suppression: Low intensity of emotions and negative belief/prediction about the context pressure

As highlighted in Table 2, low intensity of emotions in combination with negative belief about CP activates control state for suppression cs_{sup} . Figure 4 shades light on this situation where initially feeling state fs_b is increasing with the increase of bs . but it stops as soon as cs_{sup} gets activated. It can be seen that cs_{sup} suppresses expression of emotions but the sensor representation state srs_s and negative belief bs still remains high, that’s why expressive suppression is often regarded as maladaptive emotion regulation strategy.

Just as Fig. 4, in Fig. 5 too, as the person’s emotional intensity is increasing, it activates two strategies. Initially, when the intensity of negative emotions is yet low and as belief about the CP is already negative (i.e. he is predicting an environment where he can afford if his expression of emotions is observed), control state for suppression cs_{sup} gets activated. Its affect can also be seen in fs_b .

Later on, as the intensity of emotions gets higher and as the belief about CP is already negative, control state for attention deployment $cs_{a,d}$ gets activated. Activation of $cs_{a,d}$ decreases intensity of the stimuli and therefore, the bs also decreases, resulting in decrease of fs_b .

The results obtained from the model in Fig. 1 are in line with the literature from psychology and social sciences and best describe the working of emotion regulation strategies as described in the aforementioned literature.

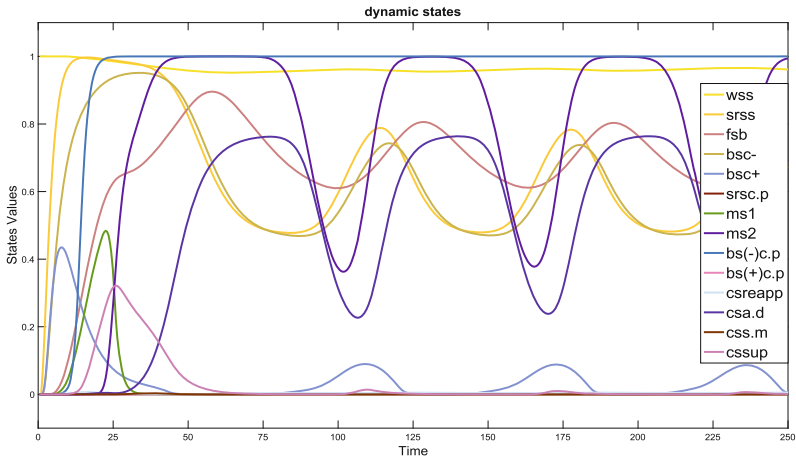

Fig. 5. Attention Deployment: high intensity of emotions and negative belief/prediction about the context pressure

5 Conclusion

This network-oriented temporal-causal network model models four different emotion regulation strategies with four different contexts. Each strategy depends on a specific context which activates it. The model not only acknowledges the ongoing debate about impact of context on various emotion regulation strategies, it rather efficiently and with computational clarity highlights the flexibility of the emotion regulation strategies dependent on a specific context.

Context plays a very profound impact in selection of a strategy. A strategy may not be as efficient in one context as it could be in another context. Therefore, a strategy can't be termed as maladaptive just because it's not adaptive in one context. Similarly, flexibility is referred to as a practice of healthy minds [3, 26] which this model has highlighted by being able to switch between different strategies as per demand of the context. Moreover, this model also gives hint to the possibility of modeling simultaneous activation of multiple strategies as found by as described in [27] For instance, in case of situation modification or attention deployment, it's possible that reappraisal or suppression is also activated at the same time, respectively. This phenomenon can be considered for further study.

This model, apart from giving insight into the phenomenon of flexibility of emotion regulation strategies, also acknowledges the strength of network oriented temporal-causal modeling [24, 28] of being able to effectively model such problems and give a clear insight into its working mechanisms.

To carry on with flexibility, in future, some other emotion regulation strategies with explicit decision-making ability maybe modeled to give insight into their working mechanism. Moreover, simultaneous activation of multiple emotion regulation strategies, from a broader repertoire, can also be considered as future project.

References

1. Aldao, A.: The future of emotion regulation research. *Perspect. Psychol. Sci.* **8**(2), 155–172 (2013). <https://doi.org/10.1177/1745691612459518>
2. Aldao, A., Sheppes, G., Gross, J.J.: Emotion regulation flexibility. *Cognit. Ther. Res.* **39**(3), 263–278 (2014). <https://doi.org/10.1007/s10608-014-9662-4>
3. Bonanno, G.A., Burton, C.L.: Regulatory flexibility. *Perspect. Psychol. Sci.* **8**(6), 591–612 (2013). <https://doi.org/10.1177/1745691613504116>
4. Ullah, N., Treur, J., Koole, S.L.: A computational model for flexibility in emotion regulation. *Procedia Compu. Sci.* **145**, 572–580 (2018). <https://doi.org/10.1016/j.procs.2018.11.100>
5. Gross, J.J., et al.: Emotion regulation: current status and future prospects. *Psychol. Inquiry* **26**(1), 1–26 (2015). <https://doi.org/10.1080/1047840x.2014.940781>
6. Koole, S.L., Aldao, A.: The self-regulation of emotion: theoretical and empirical advances. In: Vohs, K.D., Baumeister, R.F. (eds.) *Handbook of Self-Regulation*, pp. 1–36. Guilford Press, New York (2015)
7. Webb, T.L., Miles, E., Sheeran, P.: Dealing with feeling: a meta-analysis of the effectiveness of strategies derived from the process model of emotion regulation. *Psychol. Bull.* **138**(4), 775–808 (2012). <https://doi.org/10.1037/a0027600>
8. Koole, S.L.: The psychology of emotion regulation: An integrative review. *Cognit. Emotion* **23**(1), 4–41 (2009). <https://doi.org/10.1080/02699930802619031>
9. Aldao, A., Nolen-Hoeksema, S.: When are adaptive strategies most predictive of psychopathology? *J. Abnorm. Psychol.* **121**(1), 276–281 (2012). <https://doi.org/10.1037/a0023598>
10. Sloan, E., Hall, K., Moulding, R., Bryce, S., Mildred, H., Staiger, P.K.: Emotion regulation as a transdiagnostic treatment construct across anxiety, depression, substance, eating and borderline personality disorders: a systematic review. *Clinical Psychol. Rev.* **57**, 141–163 (2017). <https://doi.org/10.1016/j.cpr.2017.09.002>
11. Moses, E.B., Barlow, D.H.: A new unified treatment approach for emotional disorders based on emotion science. *Curr. Dir. Psychol. Sci.* **15**(3), 146–150 (2006). <https://doi.org/10.1111/j.0963-7214.2006.00425.x>
12. Buruck, G., Dorfel, D., Kugler, J., Brom, S.S.: Enhancing well-being at work: The role of emotion regulation skills as personal resources. *J. Occup. Health Psychol.* **21**(4), 480–493 (2016). <https://doi.org/10.1037/ocp0000023>
13. Gross, J.J.: The emerging field of emotion regulation: an integrative review. *Rev. Gen. Psychol.* **2**(3), 271–299 (1988). <https://doi.org/10.1037/1089-2680.2.3.271>
14. Richards, J.M., Gross, J.J.: Emotion regulation and memory: The cognitive costs of keeping one’s cool. *J. Pers. Soc. Psychol.* **79**(3), 410–424 (2000). <https://doi.org/10.1037/0022-3514.79.3.410>
15. Gross, J.J.: The extended process model of emotion regulation: elaborations, applications, and future directions. *Psychol. Inquiry* **26**(1), 130–137 (2015). <https://doi.org/10.1080/1047840x.2015.989751>
16. Gross, J.J.: Antecedent- and response-focused emotion regulation: Divergent consequences for experience, expression, and physiology. *J. Pers. Soc. Psychol.* **74**(1), 224–237 (1998). <https://doi.org/10.1037/0022-3514.74.1.224>
17. Ford, B.Q., Kamilowicz, H.R., Mauss, I.B.: Understanding reappraisal as a multicomponent process: the psychological health benefits of attempting to use reappraisal depend on reappraisal success. *Emotion* **17**(6), 905–911 (2017). <https://doi.org/10.1037/emo0000310>

18. Troy, A.S., Shallcross, A.J., Mauss, I.B.: A person-by-situation approach to emotion regulation: cognitive reappraisal can either help or hurt, depending on the context. *Psychol. Sci.* **24**(12), 2505–2514 (2013). <https://doi.org/10.1177/0956797613496434>
19. Veenstra, L., Schneider, I.K., Koole, S.L.: Embodied mood regulation: the impact of body posture on mood recovery, negative thoughts, and mood-congruent recall. *Cognit. Emotion* **31**(7), 1361–1376 (2017). <https://doi.org/10.1080/02699931.2016.1225003>
20. Dworkin, J.D., Zimmerman, V., Waldinger, R.J., Schulz, M.S.: Capturing naturally occurring emotional suppression as it unfolds in couple interactions. *Emotion* **19**(7), 1224–1235 (2019). <https://doi.org/10.1037/emo0000524>
21. Sheppes, G.: Emotion regulation choice: theory and findings. In: *Handbook of Emotion Regulation*, 2nd edn., pp. 126–139. Guilford Press, New York (2014)
22. Sheppes, G., Scheibe, S., Suri, G., Gross, J.J.: Emotion-regulation choice. *Psychol. Sci.* **22**(11), 1391–1396 (2011). <https://doi.org/10.1177/0956797611418350>
23. Bonanno, G.A., Wortman, C.B., Nesse, R.M.: Prospective patterns of resilience and maladjustment during widowhood. *Psychol. Aging* **19**(2), 260–271 (2004). <https://doi.org/10.1037/0882-7974.19.2.260>
24. Treur, J.: Network-oriented modeling and its conceptual foundations. *Network-Oriented Modeling*. UCS, pp. 3–33. Springer, Cham (2016). https://doi.org/10.1007/978-3-319-45213-5_1
25. Manzoor, A., Abro, A.H., Treur, J.: Monitoring the impact of negative events and deciding about emotion regulation strategies. In: Criado Pacheco, N., Carrascosa, C., Osman, N., Julián Inglada, V. (eds.) *EUMAS/AT -2016*. LNCS (LNAI), vol. 10207, pp. 350–363. Springer, Cham (2017). https://doi.org/10.1007/978-3-319-59294-7_30
26. Kashdan, T.B., Rottenberg, J.: Psychological flexibility as a fundamental aspect of health. *Clinical Psychol. Rev.* **30**(7), 865–878 (2010). <https://doi.org/10.1016/j.cpr.2010.03.001>
27. Dixon-Gordon, K.L., Aldao, A., De Los Reyes, A.: Emotion regulation in context: examining the spontaneous use of strategies across emotional intensity and type of emotion. *Pers. Individ. Differ.* **86**, 271–276 (2015). <https://doi.org/10.1016/j.paid.2015.06.011>
28. Treur, J.: *Network-Oriented Modeling for Adaptive Networks: Designing Higher-Order Adaptive Biological, Mental and Social Network Models*. SSDC, vol. 251. Springer, Cham (2020). <https://doi.org/10.1007/978-3-030-31445-3>