

TANGLE FLOER HOMOLOGY AND COBORDISMS BETWEEN TANGLES

AKRAM ALISHAHI AND EAMAN EFTEKHARY

ABSTRACT. We introduce a generalization of oriented tangles, which are still called *tangles*, so that they are in one-to-one correspondence with the sutured manifolds. We define cobordisms between sutured manifolds (tangles) by generalizing cobordisms between oriented tangles. For every commutative algebra \mathbb{A} over $\mathbb{Z}/2\mathbb{Z}$, we define \mathbb{A} -Tangles to be the category consisting of \mathbb{A} -tangles, which are balanced tangles with \mathbb{A} -colorings of the tangle strands and fixed Spin^c structures, and \mathbb{A} -cobordisms as morphisms. An \mathbb{A} -cobordism is a cobordism with a compatible \mathbb{A} -coloring and an *affine* set of Spin^c structures. Associated with every \mathbb{A} -module \mathbb{M} we construct a functor

$$\text{HF}^{\mathbb{M}} : \mathbb{A}\text{-Tangles} \longrightarrow \mathbb{A}\text{-Modules},$$

called the *tangle Floer homology functor*, where $\mathbb{A}\text{-Modules}$ denotes the the category of \mathbb{A} -modules and \mathbb{A} -homomorphisms between them. Moreover, for any \mathbb{A} -tangle \mathcal{T} the \mathbb{A} -module $\text{HF}^{\mathbb{M}}(\mathcal{T})$ is the extension of sutured Floer homology defined in an earlier work of the authors.

In particular, this construction generalizes the 4-manifold invariants of Ozsváth and Szabó. Moreover, applying the above machinery to decorated cobordisms between links, we get functorial maps on link Floer homology.

CONTENTS

1. Introduction	2
1.1. Introduction and background	2
1.2. Main results	4
1.3. Examples and applications	6
1.4. Outline of the paper	7
2. Tangles, Spin^c structures and Heegaard poly-tuples	8
2.1. Sutured manifolds and tangles	8
2.2. Heegaard Floer homology for tangles	8
2.3. Spin^c structures over cobordisms	9
2.4. Heegaard poly-tuples	10
2.5. \mathbb{A} -diagrams and holomorphic polygon maps	11
3. Tangle complex and the issue of naturality	13
3.1. Oriented graph of isotopy Heegaard diagrams	13
3.2. Special Heegaard diagrams	13
3.3. Weak Heegaard invariance	14
3.4. Strong Heegaard invariance	16
3.5. The action of $\Lambda^*(H_1(M, \mathbb{Z})/\text{Tors})$	18
4. Parametrized Cerf decomposition	19
4.1. Parametrized elementary cobordism	19
4.2. Parametrized Morse data	20
4.3. Cerf moves	23
4.4. Parametrized Cerf decomposition theorem	26
4.5. Ordered Morse data and parametrized decompositions	33
5. One-handles, Three-handles and the cobordism maps	35
5.1. Adding one-handles	35
5.2. Stretching the necks in Heegaard diagrams	35
5.3. Construction of the cobordism map	37
5.4. Proof of Lemma 5.3	38

5.5. Invariance of the cobordism map for one-handles	39
5.6. Three-handles	41
6. Framed arcs, framed knots and cobordism maps	42
6.1. Special tangles corresponding to cobordisms	42
6.2. The distinguished generator	44
6.3. Framed arcs, framed knots and the cobordism map	47
6.4. Proof of Theorem 6.9	51
7. The cobordism map and its invariance	53
7.1. Invariance under arc slides.	54
7.2. A composition law for framed arcs and links	55
7.3. The composition law	58
7.4. Action of $\Lambda^*(H_1(W, \mathbb{Z})/\text{Tors})$	61
7.5. Relative Spin^c structures and the cobordism map	62
8. Applications and special cases	64
8.1. Cobordisms between closed 3-manifolds	64
8.2. Functoriality of link Floer homology	64
References	66

1. INTRODUCTION

1.1. Introduction and background. Ozsváth and Szabó introduced Heegaard Floer homology for closed three dimensional manifolds [OS04c, OS04b] which resulted in powerful tools for the study of various structures in low dimensional topology, including invariants for knots [OS04a, Ras02, Eft05], for links [OS08], for contact structures [OS05] and for sutured manifolds [Juh06, AE15]. Juhász and Thurston [JT] showed that the Heegaard Floer groups associated with three-dimensional objects (closed manifolds, links and sutured manifolds) are in fact functors which associate a concrete module to any of the aforementioned topological objects, rather than just the isomorphism class of it. Typically, Heegaard Floer homology groups come in different flavours, which are denoted by $\widehat{\text{HF}}$, HF^+ , HF^- and HF^∞ , besides many other flavours which appear in knot and link Floer homology theories. The simplest version of these invariants, $\widehat{\text{HF}}$ and $\widehat{\text{HFK}}$, has been generalized to compact, non-closed 3-manifolds, with a specific one on the boundary, called sutured manifolds by Juhász. The authors gave a framework that generalizes sutured Floer homology and brings all flavours of Heegaard Floer homology under the same roof in [AE15].

In this paper, to define a natural notion of cobordism between sutured manifolds, that generalizes cobordisms between 3-manifolds, knots and links, we introduce a generalization of classical oriented tangles such that they are in one-to-one correspondence with sutured manifolds without toroidal sutures. So, we call our Heegaard Floer invariants, *tangle Floer homology*, and denote it by HF .

Definition 1.1. A *tangle* (M, T) is an oriented 3-manifold M with boundary and a properly embedded, oriented 1-manifold T . Both M and T have no closed components, ∂M is equipped with a fixed decomposition $\partial M = \partial^+ M \amalg \partial^- M$ such that $\partial^- T \subset \partial^- M$ and $\partial^+ T \subset \partial^+ M$.

The tangle (M, T) is called *balanced* if every component of ∂M intersects T and for every connected component M_o of M , $\chi(\partial^+ M_o) = \chi(\partial^- M_o)$.

Fix an algebra \mathbb{A} over $\mathbb{F} = \mathbb{Z}/2\mathbb{Z}$ (which will always be commutative through this paper). For every connected component $s \in \pi_0(\partial^\circ M)$ and any map $\mathbf{u} : \pi_0(T) \rightarrow \mathbb{A}$ define

$$\mathbf{u}(s) := \prod_{\substack{t \in \pi_0(T) \\ i_T^\circ(t) = s}} \mathbf{u}(t)$$

where $\circ = +, -$ and $i_T^\circ : \pi_0(T) = \pi_0(\partial^\circ T) \rightarrow \pi_0(\partial^\circ M)$ is the map induced by the inclusion $\partial^\circ T \subset \partial^\circ M$.

Definition 1.2. An \mathbb{A} -coloring for a balanced tangle (M, T) is a map $\mathbf{u} : \pi_0(T) \rightarrow \mathbb{A}$ satisfying the following two conditions.

- (1) If $s \in \pi_0(\partial M)$ corresponds to a connected component with positive genus, then $\mathbf{u}(s) = 0$,
- (2) For every connected component M_o of M

$$\sum_{s \in \pi_0(\partial^+ M_o)} \mathbf{u}(s) = \sum_{s \in \pi_0(\partial^- M_o)} \mathbf{u}(s),$$

In particular, $\mathbb{A} = \mathbb{F}$ and $\mathbf{u} = 0$ give an \mathbb{A} -coloring for any balanced tangle.

The set $\text{Spin}^c(M)$ of Spin^c structures over a tangle (M, T) is the set of homology classes of nonzero vector fields on M which restrict to the outward normal of $\partial^+ M$ and the inward normal of $\partial^- M$.

Definition 1.3. An \mathbb{A} -tangle is a 4-tuple $\mathcal{T} = [M, T, \mathfrak{s}, \mathbf{u}]$ where (M, T) is a balanced tangle, $\mathfrak{s} \in \text{Spin}^c(M)$ is a Spin^c structure over M and $\mathbf{u} : \pi_0(T) \rightarrow \mathbb{A}$ is an \mathbb{A} -coloring of (M, T) .

If \mathcal{T} is an \mathbb{A} -tangle, we use $[M_{\mathcal{T}}, T_{\mathcal{T}}, \mathfrak{s}_{\mathcal{T}}, \mathbf{u}_{\mathcal{T}}]$ to denote the corresponding 4-tuple. Given an \mathbb{A} -module \mathbb{M} and associated with an \mathbb{A} -tangle \mathcal{T} the construction of the authors in [AE15] defines an \mathbb{A} -module

$$\text{HF}^{\mathbb{M}}(\mathcal{T}) = H_*(\text{CF}(\mathcal{T}) \otimes_{\mathbb{A}} \mathbb{M})$$

so that its isomorphism type is an invariant of \mathcal{T} . In light of Juhász and Thurston's naturality discussions in [JT], one can strengthen this result as follows.

Definition 1.4. The category $\mathbb{A}\text{-Tang}$ is defined such that:

- (1) Objects are \mathbb{A} -tangles.
- (2) Morphisms from an \mathbb{A} -tangle $\mathcal{T} = [M, T, \mathfrak{s}, \mathbf{u}]$ to another \mathbb{A} -tangle $\mathcal{T}' = [M', T', \mathfrak{s}', \mathbf{u}']$ are the diffeomorphisms $d : (M, T) \rightarrow (M', T')$ such that $d^* \mathfrak{s}' = \mathfrak{s}$ and the following diagram is commutative.

$$\begin{array}{ccc} \pi_0(T) & \xrightarrow{d_*} & \pi_0(T') \\ & \searrow \mathbf{u} & \swarrow \mathbf{u}' \\ & \mathbb{A} & \end{array}$$

Here $d^* : \text{Spin}^c(M') \rightarrow \text{Spin}^c(M)$ and $d_* : \pi_0(T) \rightarrow \pi_0(T')$ are the maps induced by the diffeomorphism d .

Let $\mathbb{A}\text{-Mod}$ denote the category of \mathbb{A} -modules together with the isomorphisms between them. Using [JT, Theorem 2.39] one can prove the following theorem (see Section 3).

Theorem 1.1. For every algebra \mathbb{A} over \mathbb{F} and every \mathbb{A} -module \mathbb{M} , assigning the \mathbb{A} -module $\text{HF}^{\mathbb{M}}(\mathcal{T})$ to the \mathbb{A} -tangle \mathcal{T} in $\mathbb{A}\text{-Tang}$ gives a functor

$$\text{HF}^{\mathbb{M}} : \mathbb{A}\text{-Tang} \longrightarrow \mathbb{A}\text{-Mod}.$$

Example 1.1. Tangle Floer homology extends sutured Floer homology, as well as different versions of knot and link Floer homology in the following sense:

- (a) Let $\mathbb{A} = \mathbb{F}$. Equipping any balanced tangle (M, T) with the trivial \mathbb{A} -coloring $\mathbf{u} = 0$ and an arbitrary Spin^c class $\mathfrak{s} \in \text{Spin}^c(M)$, we have $\text{HF}^{\mathbb{F}}(M, T, \mathfrak{s}, \mathbf{u}) = \text{SFH}(M, T, \mathfrak{s})$.
- (b) Corresponding to any closed, oriented 3-manifold Y with a based point $p \in Y$, there is a tangle (Y_p, T_p) where Y_p is obtained from Y by removing two disjoint 3-balls, and $T_p \subset Y_p$ is a properly embedded, oriented arc connecting the two sphere boundary component. Furthermore, T_p passes through the point p . For $\mathbb{A} = \mathbb{F}[\mathbf{u}]$, there is a natural \mathbb{A} -coloring \mathbf{u}_p of T_p which labels T_p by \mathbf{u} . Then, for any Spin^c structure $\mathfrak{s} \in \text{Spin}^c(Y)$, setting the \mathbb{A} -module \mathbb{M} equal to $\mathbb{F}, \mathbb{F}[\mathbf{u}], \mathbb{F}[\mathbf{u}, \mathbf{u}^{-1}]$ and $\mathbb{F}[\mathbf{u}^{-1}]$ the tangle Floer homology $\text{HF}^{\mathbb{M}}(Y_p, T_p, \mathfrak{s}, \mathbf{u})$ is equal to $\widehat{\text{HF}}(Y, \mathfrak{s}), \text{HF}^-(Y, \mathfrak{s}), \text{HF}^\infty(Y, \mathfrak{s})$ and $\text{HF}^+(Y, \mathfrak{s})$, respectively.

- (c) Suppose that $L = \amalg_{i=1}^m L_i$ is an oriented link in a connected, oriented, closed 3-manifold Y and $\mathbf{p} = \{p_1, \dots, p_n\}$ is a collection of markings on L , so that each component of L contains at least one marked point. We may consider a collection of n small arcs on L containing \mathbf{p} , and remove small balls from a neighborhood of the endpoints of these arcs. This gives a 3-manifold $Y_{\mathbf{p}}$ with $2n$ sphere boundary components. The orientation on L may be used to decompose this boundary into n spheres in $\partial^+ Y_{\mathbf{p}}$ and n spheres in $\partial^- Y_{\mathbf{p}}$. After changing the orientation of the small arcs, we also obtain a tangle $L_{\mathbf{p}}$ with $2n$ connected components which connect the negative boundary to the positive boundary. Let $\mathbb{A} = \mathbb{F}[\mathbf{u}_1, \dots, \mathbf{u}_n, \mathbf{v}_1, \dots, \mathbf{v}_m]$, and label the small arc containing p_i by \mathbf{u}_i and the remaining arcs on L_i by \mathbf{v}_i . This gives an \mathbb{A} -coloring of $(Y_{\mathbf{p}}, L_{\mathbf{p}})$, denote by $\mathbf{u}_{\mathbf{p}}$, which assigns the variables $\mathbf{u}_1, \dots, \mathbf{u}_n$ to the marked points in \mathbf{p} and the variables $\mathbf{v}_1, \dots, \mathbf{v}_m$ to the connected components of the link L . For any Spin^c structure $\mathfrak{s} \in \text{Spin}^c(Y)$, the tangle Floer homology groups $\text{HF}^{\mathbb{M}}(Y_{\mathbf{p}}, L_{\mathbf{p}}, \mathbf{u}_{\mathbf{p}}, \mathfrak{s})$ give the usual link Floer homology groups associated with L using different \mathbb{A} -modules \mathbb{M} . In particular, for any knot $K \subset S^3$ with one based point p , $\text{HF}^{\frac{\mathbb{F}[\mathbf{u}, \mathbf{v}]}{(\mathbf{v})}}(S_p^3, K_p, \mathbf{u}_p, \mathfrak{s}) = \text{HFK}^-(K, \mathfrak{s})$.

1.2. Main results. Associated with a cobordism W from a closed, oriented 3-manifold M to another closed, oriented 3-manifold M' , and a Spin^c class $\mathfrak{t} \in \text{Spin}^c(W)$, Ozsváth and Szabó construct the homomorphisms

$$\mathfrak{f}_{W, \mathfrak{t}}^{\circ} : \text{HF}^{\circ}(M, \mathfrak{t}|_M) \longrightarrow \text{HF}^{\circ}(M', \mathfrak{t}|_{M'}).$$

With Theorem 1.1 in place, it is natural to ask if the construction of Ozsváth and Szabó may be extended to an invariant for cobordisms between tangles. First, we define the notion of cobordisms between tangles, by generalizing the notion of cobordisms between classical tangles.

Definition 1.5. A *cobordism* (W, F) from (M, T) to (M', T') consists of a smooth oriented four-manifold W , with boundary and corners and without closed components, and a properly embedded smooth oriented surface F in W , with boundary and corners and without closed components, such that:

- (1) The boundary $(\partial W, \partial F)$ of (W, F) consists of a horizontal part

$$\begin{aligned} (\partial_h W, \partial_h F) &= (\partial_h^+ W, \partial_h^+ F) \amalg (\partial_h^- W, \partial_h^- F) \\ &= (\partial^+ M \times I, \partial^+ T \times I) \amalg (\partial^- M \times I, \partial^- T \times I) \\ &= (\partial^+ M' \times I, \partial^+ T' \times I) \amalg (\partial^- M' \times I, \partial^- T' \times I) \end{aligned}$$

and a vertical part $(\partial_v W, \partial_v F) = -(M, T) \amalg (M', T')$, with corners

$$(\partial_v W, \partial_v F) \cap (\partial_h W, \partial_h F) = (\partial M, \partial T) \amalg (\partial M', \partial T').$$

- (2) For every component F_{\circ} of F the orientation induced on ∂F_{\circ} by the orientation of F_{\circ} agrees with the orientation inherited from $-T \amalg T'$.

The cobordism (W, F) is called *stable* if (M, T) and (M', T') are balanced and for every connected component F_{\circ} of F which is not homeomorphic to a disk, $T \cap F_{\circ}$ and $T' \cap F_{\circ}$ have more than one connected component.

Assume that (W, F) is a stable cobordism from a balanced tangle (M, T) to a balanced tangle (M', T') , as above. The inclusions of T and T' in F induce maps

$$j_T : \pi_0(T) \rightarrow \pi_0(F) \quad \text{and} \quad j_{T'} : \pi_0(T') \rightarrow \pi_0(F).$$

Definition 1.6. An \mathbb{A} -coloring for (W, F) is a map $\mathbf{u} : \pi_0(F) \rightarrow \mathbb{A}$ such that $\mathbf{u} \circ j_T$ and $\mathbf{u} \circ j_{T'}$ are \mathbb{A} -colorings for (M, T) and (M', T') , respectively.

Let $\text{Spin}^c(W)$ denote the set of Spin^c structures on W (Definition 2.4). By an *affine set* of Spin^c structures over W we mean a subset $\mathfrak{X} = \mathfrak{t} + H_{\mathfrak{X}} \subset \text{Spin}^c(W)$ which is determined by a Spin^c

structure $\mathfrak{t} \in \text{Spin}^c(W)$ and a submodule of $\text{Ker}(\pi) \subset H^2(W, \mathbb{Z})$. Here, π is the map from the cohomology long exact sequence

$$\cdots \longrightarrow H^2(W, M \amalg M', \mathbb{Z}) \xrightarrow{\iota} H^2(W, \mathbb{Z}) \xrightarrow{\pi} H^2(M \amalg M', \mathbb{Z}) \longrightarrow \cdots$$

for $(W, M \amalg M')$. In particular, if this fixed submodule is trivial, then \mathfrak{T} consists of a single Spin^c structure \mathfrak{t} . If $\mathfrak{t} - \mathfrak{t}' \in \text{ker}(\pi)$, then $\mathfrak{t}|_M = \mathfrak{t}'|_M$ and $\mathfrak{t}|_{M'} = \mathfrak{t}'|_{M'}$, so $\mathfrak{T}|_M$ and $\mathfrak{T}|_{M'}$ are well-defined.

Definition 1.7. An \mathbb{A} -cobordism $\mathcal{C} = [W, F, \mathfrak{T}, \mathbf{u}]$ from \mathcal{T} to \mathcal{T}' consists of a stable cobordism (W, F) from (M, T) to (M', T') , an affine set $\mathfrak{T} \subset \text{Spin}^c(W)$ of Spin^c structure over W , and an \mathbb{A} -coloring $\mathbf{u} : \pi_0(F) \rightarrow \mathbb{A}$ so that

$$\mathcal{T} = [M, T, \mathfrak{s} = \mathfrak{T}|_M, \mathbf{u} \circ j_T] \quad \text{and} \quad \mathcal{T}' = [M', T', \mathfrak{s}' = \mathfrak{T}|_{M'}, \mathbf{u} \circ j_{T'}].$$

If \mathcal{C} is an \mathbb{A} -cobordism from \mathcal{T} to \mathcal{T}' , we write $\mathcal{C} : \mathcal{T} \rightsquigarrow \mathcal{T}'$.

The 4-tuple associated with an \mathbb{A} -cobordism \mathcal{C} is denoted by $[W_{\mathcal{C}}, F_{\mathcal{C}}, \mathfrak{T}_{\mathcal{C}}, \mathbf{u}_{\mathcal{C}}]$ and we set $\text{Spin}^c(\mathcal{C}) = \text{Spin}^c(W_{\mathcal{C}})$. When \mathfrak{T} consists of a single Spin^c structure \mathfrak{t} , we abuse the notation and denote it by \mathfrak{t} (or use similar notation for it).

Using affine sets of Spin^c structures instead of single Spin^c structures over cobordisms allows us to compose \mathbb{A} -cobordisms. In fact, if

$$\mathcal{C}_1 = [W_1, F_1, \mathfrak{T}_1, \mathbf{u}_1] : \mathcal{T} \rightsquigarrow \mathcal{T}' \quad \text{and} \quad \mathcal{C}_2 = [W_2, F_2, \mathfrak{T}_2, \mathbf{u}_2] : \mathcal{T}' \rightsquigarrow \mathcal{T}''$$

are \mathbb{A} -cobordisms, then the Mayer-Vietoris exact sequence

$$\cdots \longrightarrow H^1(M_{\mathcal{T}'}, \mathbb{Z}) \xrightarrow{\delta} H^2(W, \mathbb{Z}) \xrightarrow{\pi} H^2(W_1, \mathbb{Z}) \oplus H^2(W_2, \mathbb{Z}) \longrightarrow \cdots$$

for $W = W_1 \cup W_2$, and the submodules corresponding to \mathfrak{T}_1 and \mathfrak{T}_2 determine a submodule of $H^2(W, \mathbb{Z})$ as their pre-image under π . Since \mathfrak{T}_1 restricts to $\mathfrak{s} = \mathfrak{s}_{\mathcal{T}}$ on $M = M_{\mathcal{T}}$ and \mathfrak{T}_2 restricts to $\mathfrak{s}'' = \mathfrak{s}_{\mathcal{T}''}$ on $M'' = M_{\mathcal{T}''}$, this submodule determines an affine set \mathfrak{T} of Spin^c structures on W , which is bigger than $\mathfrak{T}_1 \times \mathfrak{T}_2$ unless the map δ in the above sequence is trivial. We may then compose the \mathbb{A} -cobordisms \mathcal{C}_1 and \mathcal{C}_2 to obtain

$$\mathcal{C} = \mathcal{C}_1 \cup_{\mathcal{T}'} \mathcal{C}_2 : \mathcal{T} \rightsquigarrow \mathcal{T}''.$$

Definition 1.7 gives a category \mathbb{A} -Tangles. The objects of \mathbb{A} -Tangles are \mathbb{A} -tangles and the morphisms are \mathbb{A} -cobordisms. The category \mathbb{A} -Tang is a subcategory of \mathbb{A} -Tangles: given a diffeomorphism

$$d : [M, T, \mathfrak{s}, \mathbf{u}] \rightarrow [M', T', \mathfrak{s}', \mathbf{u}']$$

define an \mathbb{A} -cobordism $\mathcal{C} = [W, F, \mathfrak{t}, \mathbf{u}_F]$, where $(W, F) = (M, T) \times [0, 1]$, and $(M, T) \times \{1\}$ is identified with (M', T') by the diffeomorphism d . Further, the Spin^c structure \mathfrak{t} and the map \mathbf{u}_F are trivially determined by \mathfrak{s} and \mathbf{u} , respectively.

For every \mathbb{A} -cobordism \mathcal{C} from an \mathbb{A} -tangle \mathcal{T} to an \mathbb{A} -tangle \mathcal{T}' , and any \mathbb{A} -module \mathbb{M} , we define an \mathbb{A} -homomorphism

$$\mathfrak{f}_{\mathcal{C}}^{\mathbb{M}} : \text{HF}^{\mathbb{M}}(\mathcal{T}) \rightarrow \text{HF}^{\mathbb{M}}(\mathcal{T}').$$

Theorem 1.2. For every \mathbb{F} -algebra \mathbb{A} , the functor $\text{HF}^{\mathbb{M}}$ from Theorem 1.1, extends to a functor

$$\text{HF}^{\mathbb{M}} : \mathbb{A}\text{-Tangles} \longrightarrow \mathbb{A}\text{-Modules},$$

by setting $\text{HF}^{\mathbb{M}}(\mathcal{C}) = \mathfrak{f}_{\mathcal{C}}^{\mathbb{M}}$, for any \mathbb{A} -cobordism \mathcal{C} . Here, \mathbb{A} -Modules denotes the category of \mathbb{A} -modules with \mathbb{A} -homomorphisms between them.

If $\phi : \mathbb{M} \rightarrow \mathbb{M}'$ is a homomorphism of \mathbb{A} -modules, we obtain a corresponding homomorphism of \mathbb{A} -modules

$$\mathfrak{f}^{\phi} : \text{HF}^{\mathbb{M}}(\mathcal{T}) \longrightarrow \text{HF}^{\mathbb{M}'}(\mathcal{T}).$$

Given an \mathbb{A} -cobordism $\mathcal{C} : \mathcal{T} \rightsquigarrow \mathcal{T}'$, the following diagram is commutative:

$$\begin{array}{ccc} \mathrm{HF}^{\mathbb{M}}(\mathcal{T}) & \xrightarrow{\mathfrak{f}_{\mathcal{C}}^{\mathbb{M}}} & \mathrm{HF}^{\mathbb{M}}(\mathcal{T}') \\ \mathfrak{f}^{\phi} \downarrow & & \downarrow \mathfrak{f}^{\phi} \\ \mathrm{HF}^{\mathbb{M}'}(\mathcal{T}) & \xrightarrow{\mathfrak{f}_{\mathcal{C}}^{\mathbb{M}'}} & \mathrm{HF}^{\mathbb{M}'}(\mathcal{T}'). \end{array}$$

Moreover, given a short exact sequence

$$0 \longrightarrow \mathbb{M} \xrightarrow{\iota} \mathbb{M}' \xrightarrow{\pi} \mathbb{M}'' \longrightarrow 0$$

of \mathbb{A} -modules, we obtain a corresponding exact triangle of tangle Floer homology \mathbb{A} -modules:

$$\begin{array}{ccc} \mathrm{HF}^{\mathbb{M}}(\mathcal{T}) & \xleftarrow{\mathfrak{f}^{\delta}} & \mathrm{HF}^{\mathbb{M}''}(\mathcal{T}) \\ & \searrow \mathfrak{f}^{\iota} & \nearrow \mathfrak{f}^{\pi} \\ & \mathrm{HF}^{\mathbb{M}'}(\mathcal{T}) & \end{array}$$

where \mathfrak{f}^{δ} is a connecting homomorphism.

1.3. Examples and applications. Let us first review some of the familiar cases of the above construction.

Example 1.2. Let $\mathcal{Y} = (Y, p)$ and $\mathcal{Y}' = (Y', p')$ be pointed, oriented, connected and closed 3-manifolds. If X is a smooth 4-dimensional cobordism from Y to Y' and if σ is a simple path in X from p to p' , then $\mathcal{X} = (X, \sigma)$ gives a cobordism (X_{σ}, F_{σ}) from (Y_p, T_p) to $(Y_{p'}, T_{p'})$, where F_{σ} is a disk. Let \mathbf{u}_{σ} be the $\mathbb{F}[\mathbf{u}]$ -coloring that labels F_{σ} by \mathbf{u} . For every Spin^c structure $\mathfrak{t} \in \mathrm{Spin}^c(X)$, $\mathcal{C}_{\mathcal{X}, \mathfrak{t}} = (X_{\sigma}, F_{\sigma}, \mathfrak{t}, \mathbf{u}_{\sigma})$ is an \mathbb{A} -cobordism from $\mathcal{T}_{\mathcal{Y}, \mathfrak{s}}$ to $\mathcal{T}_{\mathcal{Y}', \mathfrak{s}'}$, where $\mathfrak{s} = \mathfrak{t}|_{Y_p}$ and $\mathfrak{s}' = \mathfrak{t}|_{Y_{p'}}$. In view of Example 1.1 (part (a)), when we choose \mathbb{M} equal to $\mathbb{F}, \mathbb{F}[\mathbf{u}], \mathbb{F}[\mathbf{u}^{-1}]$ or $\mathbb{F}[\mathbf{u}, \mathbf{u}^{-1}]$, the \mathbb{A} -homomorphism $\mathrm{HF}^{\mathbb{M}}(\mathcal{C}_{\mathcal{X}, \mathfrak{t}}) = \mathfrak{f}_{\mathcal{C}_{\mathcal{X}, \mathfrak{t}}}^{\mathbb{M}}$ is the cobordism map of Ozsváth and Szabó in the corresponding cases.

Example 1.3. (*Functoriality of knot and link Floer homologies*) Suppose that $(L, \mathbf{p}) \subset Y$ and $(L', \mathbf{p}') \subset Y'$ are marked links, as in Example 1.1, with $|\mathbf{p}| = |\mathbf{p}'| = n$. For a decorated cobordism $\mathcal{Z} = (Z, F, \sigma)$ consisting of a smooth, oriented, 4-dimensional cobordism Z from Y to Y' , a properly embedded, smooth, oriented surface $F \subset Z$ which connects L to L' and a properly embedded, oriented 1-manifold $\sigma \subset F$ which connects \mathbf{p} to \mathbf{p}' i.e. $\partial^{-}\sigma = \mathbf{p}$ and $\partial^{+}\sigma = \mathbf{p}'$, we construct a cobordism (X_{σ}, F_{σ}) connecting $(Y_{\mathbf{p}}, L_{\mathbf{p}})$ to $(Y'_{\mathbf{p}'}, L'_{\mathbf{p}'})$. We require that σ does not have any closed components and that any connected component of $F - \sigma$ with positive genus intersects L and L' in more than one connected component, to achieve stability. Then the connected components $\sigma_1, \dots, \sigma_n$ give a matching between \mathbf{p} and \mathbf{p}' . We may thus assume that the endpoints of σ_i are $p_i \in \mathbf{p}$ and $p'_i \in \mathbf{p}'$, for $i = 1, \dots, n$.

Let us assume that $F = \coprod_{j=1}^m F_j$ and set $\mathbb{A} = \mathbb{F}[\mathbf{u}_1, \dots, \mathbf{u}_n, \mathbf{v}_1, \dots, \mathbf{v}_m]$. The \mathbb{A} -coloring of (X_{σ}, F_{σ}) is given by labeling the disk associated with each σ_i by \mathbf{u}_i , and labeling each connected component of $F_j \setminus \sigma$ by \mathbf{v}_j . If $\mathbb{A}_{L, \mathbf{p}}$ denotes the ring associated with the marked link (L, \mathbf{p}) , there is a quotient map from $\mathbb{A}_{L, \mathbf{p}}$ to \mathbb{A} . If two link components in L are on the boundary of the same connected component of F , the variables associated to these link components by $\mathbf{u}_{\mathbf{p}}$ are identified in the quotient. In particular, if each connected component of F intersects precisely one connected component of each one L and L' , $\mathbb{A}_{L, \mathbf{p}}$ and $\mathbb{A}_{L', \mathbf{p}'}$ are both identified with \mathbb{A} . In this case, we call (Z, F, σ) a *decorated link cobordism* from (Y, L, \mathbf{p}) to (Y', L', \mathbf{p}') .

Let us assume that (Z, F, σ) is a decorated link cobordism from (Y, L, \mathbf{p}) to (Y', L', \mathbf{p}') . Associated with every Spin^c structure $\mathfrak{t} \in \text{Spin}^c(Z)$ we obtain an \mathbb{A} -cobordism

$$\mathcal{C}_{Z, \mathfrak{t}} = [W_Z, F_Z, \mathfrak{t}, \mathbf{u}_Z] : \mathcal{T}_{L, \mathbf{p}, \mathfrak{t}|_Y} \rightsquigarrow \mathcal{T}_{L', \mathbf{p}', \mathfrak{t}|_{Y'}}.$$

Correspondingly, we obtain the cobordism maps

$$\mathfrak{f}_{Z, \mathfrak{t}}^{\mathbb{M}} : \text{HF}^{\mathbb{M}}(Y, L, \mathbf{p}, \mathfrak{t}|_Y) \rightarrow \text{HF}^{\mathbb{M}}(L', \mathbf{p}', \mathfrak{t}|_{Y'}).$$

The functoriality of link Floer homology then follows from our main theorem.

Remark 1.3. *A similar construction, in the context of pointed links and cobordisms between them, is independently given by Ian Zemke in [Zem].*

Suppose that the oriented knots K and K' differ by changing one crossing. Corresponding to this crossing change there is a cobordism obtained by a band attachment from K to $L = K' \# H$, where H is the right- or left-handed Hopf link. In [AE], we use the corresponding cobordism maps for appropriate choices of based points on K and L and decoration on the cobordism, and we define a lower bound $\mathfrak{l}(K)$ on the unknotting number of K . This bound is greater than or equal to $\nu^-(K)$, $\nu^-(-K)$ and the order of U -torsions in $\text{HFK}^-(K)$. Additionally, it only vanishes for the unknot, and we present examples of slice knots K such that $\mathfrak{l}(K)$ is arbitrarily large. A parallel construction is used by the first author in [Ali] to construct lower bounds on the unknotting number from Khovanov homology, also see [AD].

1.4. Outline of the paper. The paper is organized as follows. In Section 2 we review Heegaard poly-tuples and Spin^c structures over them. Then in Section 3 we follow the footsteps of Juhász and Thurston [JT] to show that tangle Floer homology for \mathbb{A} -tangles gives functors from $\mathbb{A}\text{-Tang}$ to $\mathbb{A}\text{-Mod}$. In Section 4 we study parametrized Cerf decompositions of cobordisms between tangles. We show that any two parametrized Cerf decompositions for a stable cobordism can be connected by a sequence of Cerf moves.

In Section 5 we define cobordism maps for parametrized cobordisms associated with attaching one or three handles and show that the map is invariant. In Section 6 we introduce a special \mathbb{A} -tangle \mathcal{T}_F associated to the positive boundary of any \mathbb{A} -cobordism together with a distinguished generator $\Theta_F \in \text{HF}(\mathcal{T}_F)$. The distinguished generator makes it possible to define invariant cobordism maps for cobordisms parametrized with framed links and framed arcs. In Section 7 we define cobordism maps for arbitrary \mathbb{A} -cobordisms by composing cobordism maps constructed in Sections 5 and 6 for cobordisms parametrized by framed 0-spheres, framed knots and arcs and framed 2-spheres. We prove that this map is in fact an invariant and does not depend on the parametrized Cerf decomposition. Moreover, we show that this construction gives functors from $\mathbb{A}\text{-Tangles}$ to $\mathbb{A}\text{-Modules}$. Finally in Section 8 we discuss some special cases and applications. In particular, decorated cobordisms between pointed links induce functorial maps on link Floer homology.

Acknowledgements. The authors would like to thank András Juhász and Robert Lipshitz for helpful discussions and suggestions. Most of this work was done when the first author was a postdoc at Max Planck Institute for Mathematics (MPIM) in Bonn. She gratefully acknowledges the support and the hospitality of MPIM through this period.

2. TANGLES, Spin^c STRUCTURES AND HEEGAARD POLY-TUPLES

In this section, we describe the correspondence between sutured manifolds and tangles. Then, we review some definitions and results from [AE15] about Heegaard Floer homology for tangles (sutured manifolds), to fix our notation. We will also reformulate some definitions and results about Heegaard diagrams, Heegaard poly-tuples and Spin^c structures from [AE15, GW10, OS04c, OS06] to work in our setup.

2.1. Sutured manifolds and tangles. Sutured manifolds were introduced by Gabai in [Gab83, Gab87a, Gab87b]. Throughout this paper, we use a less general family of sutured manifolds by excluding toroidal sutures.

Definition 2.1. A *sutured manifold* (X, τ) is an oriented 3-manifold X with boundary, together with a set of pairwise disjoint, oriented, simple closed curves $\tau = \{\tau_1, \dots, \tau_\kappa\}$ on ∂X . We will denote by $A(\tau_i)$ a tubular neighborhood of τ_i in ∂X , which is an annulus. We let $A(\tau) = A(\tau_1) \amalg \dots \amalg A(\tau_\kappa)$. Every connected component of $\mathfrak{R}(\tau) = \partial X \setminus A(\tau)^\circ$ is oriented with the orientation induced from X , where $A(\tau)^\circ$ denotes the interior of $A(\tau)$. Furthermore, we require that $\mathfrak{R}(\tau) = \mathfrak{R}^+(\tau) \amalg \mathfrak{R}^-(\tau)$ where $\mathfrak{R}^+(\tau)$ (respectively, $\mathfrak{R}^-(\tau)$) denotes the union of components of $\mathfrak{R}(\tau)$ such that the orientation induced on τ as the boundary of $\mathfrak{R}^+(\tau)$ (respectively, $\mathfrak{R}^-(\tau)$) agrees with (respectively, is the opposite of) the orientation of τ .

Every sutured manifold (X, τ) determines a tangle (M, T) , where $M = \overline{X}$ is obtained from X by filling the sutures (i.e. attaching 2-handles along the sutures) and T is the set of cocores of these 2-handles. The orientation on τ induces an orientation on T and the decomposition $\partial \mathfrak{R}(\tau) = \mathfrak{R}^+(\tau) \amalg \mathfrak{R}^-(\tau)$ induces a decomposition $\partial M = \partial^+ M \amalg \partial^- M$ of the boundary of M . Conversely, every tangle (M, T) determines a sutured manifold (X, τ) where $X = M \setminus \text{nd}(T)$ and τ is the set of meridians of T along with the induced orientation.

Note that a tangle (M, T) is balanced if and only if the corresponding sutured manifold is balanced in the sense of [Juh06, Definition 2.2].

In [AE15], we introduced a \mathbb{Z} -algebra \mathbb{A}_τ associated to the boundary of any balanced sutured manifold (X, τ) . Assume $\tau = \amalg_{i=1}^\kappa \tau_i$,

$$\mathfrak{R}^-(\tau) = \coprod_{i=1}^k R_i^- \quad \text{and} \quad \mathfrak{R}^+(\tau) = \coprod_{j=1}^l R_j^+.$$

Associated with the connected components of $\mathfrak{R}(\tau)$, consider the elements

$$\mathbf{u}_i^- := \prod_{\tau_j \subset \partial R_i^-} \mathbf{u}_j, \quad i = 1, \dots, k \quad \text{and} \quad \mathbf{u}_i^+ := \prod_{\tau_j \subset \partial R_i^+} \mathbf{u}_j, \quad i = 1, \dots, l,$$

in the free \mathbb{Z} -algebra $\mathbb{Z}[\mathbf{u}_1, \dots, \mathbf{u}_\kappa]$ generated by $\mathbf{u}_1, \dots, \mathbf{u}_\kappa$. Then

$$\mathbb{A}_\tau = \frac{\mathbb{Z}[\mathbf{u}_1, \dots, \mathbf{u}_\kappa]}{\langle \mathbf{u}^+(\tau) - \mathbf{u}^-(\tau) \rangle + \langle \mathbf{u}_i^+ \mid g_i^+ > 0 \rangle + \langle \mathbf{u}_i^- \mid g_i^- > 0 \rangle}$$

where $\mathbf{u}^-(\tau) = \sum_{i=1}^k \mathbf{u}_i^-$, $\mathbf{u}^+(\tau) = \sum_{i=1}^l \mathbf{u}_i^+$ and g_i^\bullet denotes the genus of R_i^\bullet for $\bullet = +, -$. For any balanced tangle (M, T) , denote the algebra associated to its corresponding balanced sutured manifold by \mathbb{A}_T .

Suppose (M, T) be a connected balanced tangle (i.e. a balanced tangle with M connected). The map $\mathbf{u}_T : \pi_0(T) \rightarrow \mathbb{A}_T$ which sends each component T_i to the variable \mathbf{u}_i corresponding to its meridian gives an \mathbb{A}_T -coloring for (M, T) . In fact, any map $\mathbf{u} : \pi_0(T) \rightarrow \mathbb{A}$ is an \mathbb{A} -coloring for (M, T) if and only if $\mathbf{u} = \phi \circ \mathbf{u}_T$ for a homomorphism ϕ from \mathbb{A}_T to \mathbb{A} .

2.2. Heegaard Floer homology for tangles. Recall that a balanced Heegaard diagram is a 4-tuple $H = (\Sigma, \boldsymbol{\alpha}, \boldsymbol{\beta}, \mathbf{z})$ where Σ is a closed oriented surface, $\boldsymbol{\alpha}$ and $\boldsymbol{\beta}$ are sets of pairwise disjoint circles on Σ , and $\mathbf{z} \subset \Sigma \setminus (\boldsymbol{\alpha} \cup \boldsymbol{\beta})$ is a set of points. Further, $|\boldsymbol{\alpha}| = |\boldsymbol{\beta}|$ and \mathbf{z} intersects every connected component of $\Sigma \setminus \boldsymbol{\alpha}$ and $\Sigma \setminus \boldsymbol{\beta}$. Every balanced Heegaard diagram H , specifies a balanced tangle

(M, T) , where M is obtained from $\Sigma \times [0, 1]$ by attaching 2-handles along the circles $\alpha \times \{0\}$ and $\beta \times \{1\}$, and $T = \mathbf{z} \times [0, 1]$.

A Heegaard diagram for a balanced tangle (M, T) , is a balanced Heegaard diagram $H = (\Sigma, \alpha, \beta, \mathbf{z})$, so that Σ is an embedded separating surface in M which cuts T transversely in \mathbf{z} , α and β bound disjoint disks on the two sides of Σ . Moreover, let $\Sigma[\alpha]$ and $\Sigma[\beta]$ be embedded surfaces obtained from compressing Σ along the α and β curves, respectively. Then, $(\Sigma[\alpha], \mathbf{z})$ and $(\Sigma[\beta], \mathbf{z})$ are isotopic relative to T to $(\partial^- M, \partial^- T)$ and $(\partial^+ M, \partial^+ T)$, respectively.

Let $H = (\Sigma, \alpha, \beta, \mathbf{z} = \{z_1, \dots, z_\kappa\})$ be a Heegaard diagram which corresponds to a balanced tangle (M, T) . We set $\text{Spin}^c(H)$ equal to $\text{Spin}^c(M)$. For an \mathbb{F} -algebra \mathbb{A} , consider a map $\mathbf{u} : \mathbf{z} \rightarrow \mathbb{A}$. Then, corresponding to any 2-chain \mathcal{D} on Σ with boundary on $\alpha \cup \beta$, let $n_i(\mathcal{D})$ denote the coefficient of \mathcal{D} at z_i and set

$$(1) \quad \mathbf{u}(\mathcal{D}) := \prod_{i=1}^{\kappa} \mathbf{u}_i^{n_i(\mathcal{D})} \in \mathbb{A},$$

where $\mathbf{u}_i = \mathbf{u}(z_i)$. Let $\Sigma \setminus \alpha = \coprod_{i=1}^k A_i$ and $\Sigma \setminus \beta = \coprod_{j=1}^l B_j$.

Definition 2.2. With the above notation fixed, \mathbf{u} is called an \mathbb{A} -coloring for H if it satisfies the following two conditions.

- $\sum_{i=1}^k \mathbf{u}(A_i) = \sum_{j=1}^l \mathbf{u}(B_j)$,
- if A_i or B_j is not a punctured sphere, then $\mathbf{u}(A_i) = 0$ or $\mathbf{u}(B_j) = 0$, respectively.

Definition 2.3. A Heegaard diagram H , together with an \mathbb{A} -coloring \mathbf{u} and a Spin^c class $\mathfrak{s} \in \text{Spin}^c(H)$ is called an \mathbb{A} -diagram, if (H, \mathbf{u}) is \mathfrak{s} -admissible. Here, (H, \mathbf{u}) is called \mathfrak{s} -admissible if for any periodic domain \mathcal{P} with $\langle c_1(\mathfrak{s}), H(\mathcal{P}) \rangle = 0$, either $\mathbf{u}(\mathcal{P}) = 0$ or the coefficient of \mathcal{P} at some point is negative.

Any \mathbb{A} -diagram specifies an \mathbb{A} -tangle. Given an \mathbb{A} -tangle $\mathcal{T} = [M, T, \mathfrak{s}, \mathbf{u}]$, an \mathbb{A} -diagram for \mathcal{T} consists of a Heegaard diagram for (M, T) , together with the \mathbb{A} -coloring induced by \mathbf{u} and the Spin^c class induced by \mathfrak{s} .

Let $\mathcal{H} = (\Sigma, \alpha, \beta, \mathbf{u} : \mathbf{z} \rightarrow \mathbb{A}, \mathfrak{s})$ be an \mathbb{A} -diagram for the \mathbb{A} -tangle \mathcal{T} . Choose a generic path J_s of almost complex structures on $\text{Sym}^\ell(\Sigma)$, where $\ell = |\alpha| = |\beta|$. In [AE15], we construct a chain complex

$$\text{CF}_{J_s}(\Sigma, \alpha, \beta, \mathbf{u}, \mathfrak{s}),$$

which is generated by the intersection points $\mathbf{x} \in \mathbb{T}_\alpha \cap \mathbb{T}_\beta$ with $\mathfrak{s}(\mathbf{x}) = \mathfrak{s}$, and its chain homotopy type is an invariant of \mathcal{T} . We usually drop J_s from the notation for simplicity. Furthermore, for any \mathbb{A} -module \mathbb{M} the isomorphism type of the Floer homology group

$$\text{HF}^{\mathbb{M}}(\mathcal{T}) := H_*(\text{CF}(\Sigma, \alpha, \beta, \mathbf{u}, \mathfrak{s}) \otimes_{\mathbb{A}} \mathbb{M})$$

is an invariant of \mathcal{T} . For simplicity, we set $\text{HF}(\mathcal{T}) := \text{HF}^{\mathbb{A}}(\mathcal{T})$. Moreover, for any balanced tangle (M, T) , let

$$\text{HF}(M, T, \mathfrak{s}) := \text{HF}(M, T, \mathbf{u}_T : \pi_0(T) \rightarrow \mathbb{A}_T, \mathfrak{s})$$

where \mathbb{A}_T is the algebra associated to (M, T) and \mathbf{u}_T is its corresponding coloring map.

2.3. Spin^c structures over cobordisms. Given a stable cobordism (W, F) from (M, T) to (M', T') , let ξ denote the oriented 2-plane field in $\partial_h W = \partial M \times [0, 1]$ consisting of the tangent planes of the surfaces $\partial M \times \{t\}$ for any $t \in [0, 1]$. Fix an almost complex structure J_0 on $TW|_{\partial_h W}$ such that ξ consists of complex lines i.e. 2-planes in ξ are invariant under J_0 . One may further extend J_0 to an almost complex structure on F by requiring that J_0 preserves the tangent space of F . Note that the set of almost complex structures J_0 with the above property is contractible.

Definition 2.4. A Spin^c structure on W is the homology class of a pair (J, P) , where

- (1) $P \subset W \setminus \partial_h W$ is a finite collection of points,
- (2) J is an almost complex structure on $W \setminus P$ with $J|_{\partial_h W} = J_0$.

We call the pairs (J_1, P_1) and (J_2, P_2) *homologous* if there exists a compact 1-manifold $C \subset W \setminus \partial_h W$ without closed components so that $\partial C = P_1 \cup P_2$, and $J_1|_{W \setminus C}$ is isotopic relative to $\partial_h W$ to $J_2|_{W \setminus C}$. Denote the set of Spin^c structures on W by $\text{Spin}^c(W)$. Similarly, a relative Spin^c structure on the pair (W, F) is the homology class of a pair (J, P) , where $P \subset W \setminus (\partial_h W \cup F)$ is a finite collection of points and J is an almost complex structure on $W \setminus P$ which agrees with J_0 over $\partial_h W \cup F$. The notion of homologous pairs is defined similarly, the only difference is that we need to consider isotopies relative $\partial_h W \cup F$. The set of relative Spin^c structures over (W, F) is denoted by $\text{Spin}^c(W, F)$.

Since J_0 is chosen from a contractible family, the above definition does not depend on the particular choice of J_0 .

After fixing a metric over the 4-manifold W , any oriented 2-plane field which extends ξ and is defined in the complement $W - P$ determines a corresponding almost complex structure. It is not hard to show that $\text{Spin}^c(W)$ is an affine space over $H^2(W, \partial_h W; \mathbb{Z})$.

For every Spin^c structure \mathfrak{s} over W , the induced Spin^c structures $\mathfrak{s}|_M$ and $\mathfrak{s}|_{M'}$ are defined as follows. Consider an almost complex structure J (defined on $W \setminus P$) representing \mathfrak{s} . At any point p in M , J specifies a subspace $V_p = T_p M \cap J(T_p M)$ of $T_p M$. Similarly, at any $p \in M'$, it specifies a subspace $V'_p \subset T_p M'$. Let V and V' denote the corresponding plane fields in M and M' , respectively. Then, $\mathfrak{s}|_M$ and $\mathfrak{s}|_{M'}$ are defined to be the Spin^c classes represented by V and V' , respectively.

2.4. Heegaard poly-tuples. Let $H = (\Sigma, \alpha^1, \dots, \alpha^m, \mathbf{z})$ be a balanced Heegaard diagram. This means that Σ is a closed oriented surface and for any $1 \leq i \leq m$, $\alpha^i = \{\alpha_1^i, \dots, \alpha_\ell^i\}$ is a set of ℓ disjoint simple closed curves on Σ for some $\ell > 0$. Moreover, $\mathbf{z} = \{z_1, \dots, z_\kappa\}$ is a set of marked points in $\Sigma - \alpha^1 - \alpha^2 - \dots - \alpha^m$ such that for any $1 \leq i \leq m$ every connected component of $\Sigma - \alpha^i$ intersects \mathbf{z} .

Associated with the balanced Heegaard diagram H , we define a pair (W_H, F_H) as follows. For every $1 \leq i \leq m$, the Heegaard diagram $(\Sigma, \alpha^i, \emptyset, \mathbf{z})$ determines a tangle (U_i, T_i) , where $U_i = C[\alpha^i]$ is the compression body determined by α^i i.e. it is obtained from $\Sigma \times [0, 1]$ by attaching 2-handles along the curves $\alpha^i \times \{1\}$, and $T_i = \mathbf{z} \times [0, 1]$. Thus $\partial U_i = \partial^- U_i \amalg \partial^+ U_i$, where

$$\partial^- U_i = \Sigma \quad \text{and} \quad \partial^+ U_i = \Sigma[\alpha_i]$$

and $\Sigma[\alpha_i]$ is obtained by cutting Σ along α_i and attaching disks to the boundary components of the resulting surface. We denote the finite set $T_i \cap \partial^- U_i = \mathbf{z} \times \{0\}$ by \mathbf{z}_i .

Let \mathbb{D}_m be a m -gon with the vertices v_1, \dots, v_m , labelled in clockwise order, and edges e_1, \dots, e_m , where e_i connects v_{i-1} to v_i for $i = 2, \dots, m$ and e_1 connects v_m to v_1 . Define

$$W_H := \frac{(\Sigma \times \mathbb{D}_m) \amalg (\amalg_{i=1}^m U_i \times e_i)}{\Sigma \times e_i \sim \partial^- U_i \times e_i} \quad \text{and} \quad F_H := \frac{(\mathbf{z} \times \mathbb{D}_m) \amalg (\amalg_{i=1}^m T_i \times e_i)}{\mathbf{z} \times e_i \sim \mathbf{z}_i \times e_i}.$$

We smooth the corners of W_H and F_H along $v_i \times \Sigma$ for $1 \leq i \leq m$. Corresponding to any vertex v_i , we obtain a balanced tangle in $(\partial W_H, \partial F_H)$ determined by the Heegaard diagram $(\Sigma, \alpha^i, \alpha^{i+1}, \mathbf{z})$ denoted by $(M_{i,i+1}, T_{i,i+1})$. Note that $\alpha^{m+1} = \alpha^1$ and $(M_{m,m+1}, T_{m,m+1}) = (M_{m,1}, T_{m,1})$. Let

$$M' := M_{1,2} \amalg M_{2,3} \amalg \dots \amalg M_{m,1} \subset \partial W_H \quad \text{and} \quad Z := \partial W_H - \text{int}(M')$$

Thus, Z is a product and

$$Z = (\partial^- M_{1,2} \amalg \dots \amalg \partial^- M_{m,1}) \times [0, 1].$$

Fix an almost complex structure J_0 on $TW_H|_Z$ such that for any $t \in [0, 1]$ the tangent planes to the surface $(\partial^- M_{1,2} \amalg \dots \amalg \partial^- M_{m,1}) \times \{t\}$ are complex lines. The almost complex structure J_0 may further be extended to F_H so that it preserves the tangent space of F_H , i.e. the tangent planes of F_H are all complex lines. We may then talk about the Spin^c structures on W_H and the relative Spin^c structures on (W_H, F_H) .

Definition 2.5. The set of Spin^c structures on W_H , denoted by $\text{Spin}^c(W_H)$, is defined as the set of homology classes of the pairs (J, P) consisting of a finite set of points P in the interior of W_H and an almost complex structure J on $W_H - P$ such that $J|_Z = J_0$. Similarly, the set of *relative* Spin^c structures on (W_H, F_H) , denoted by $\text{Spin}^c(W_H, F_H)$, is defined as the set of homology classes of the pairs (J, P) consisting of a finite set P of points in the interior of $W_H - F_H$ and an almost complex structure J on $W_H - P$ such that $J|_{Z \cup F_H} = J_0$.

$\text{Spin}^c(W_H)$ is an affine space over $\mathbb{H}^2(W_H, Z; \mathbb{Z})$, and $\text{Spin}^c(W_H, F_H)$ is an affine space over $\mathbb{H}^2(W_H, Z \cup F_H; \mathbb{Z})$.

Let $\mathbb{T}_i \subset \text{Sym}^\ell(\Sigma)$ denote the torus $\alpha_1^i \times \cdots \times \alpha_\ell^i$. Given intersection points $\mathbf{x}_i \in \mathbb{T}_i \cap \mathbb{T}_{i+1}$, the homotopy classes of maps

$$\Psi : \mathbb{D}_m \rightarrow \text{Sym}^\ell(\Sigma) \quad \text{s.t.} \quad \Psi(v_i) = \mathbf{x}_i, \quad \Psi(e_i) \subset \mathbb{T}_i, \quad i = 1, \dots, m$$

is denoted by $\pi_2(\mathbf{x}_1, \dots, \mathbf{x}_m)$. If $\pi_2(\mathbf{x}_1, \dots, \mathbf{x}_m)$ is non-empty, [GW10, Proposition 3.3] implies that there is an affine correspondence

$$\pi_2(\mathbf{x}_1, \dots, \mathbf{x}_m) \simeq \text{Ker} \left(\bigoplus_{i=1}^m \text{Span}(\alpha^i) \rightarrow \mathbb{H}_1(\Sigma; \mathbb{Z}) \right) \cong \mathbb{H}^2(W_H, \partial W_H; \mathbb{Z})$$

where $\text{Span}(\alpha^i)$ denotes the submodule of $\mathbb{H}_1(\Sigma; \mathbb{Z})$ spanned by the elements of α^i .

Fix intersection points $\mathbf{x}_i, \mathbf{x}'_i \in \mathbb{T}_i \cap \mathbb{T}_{i+1}$ for $i = 1, \dots, m$. Two homotopy classes $\Psi \in \pi_2(\mathbf{x}_1, \dots, \mathbf{x}_m)$ and $\Psi' \in \pi_2(\mathbf{x}'_1, \dots, \mathbf{x}'_m)$ are called *equivalent* if there exist Whitney disks $\psi_i \in \pi_2(\mathbf{x}_i, \mathbf{x}'_i)$ for $i = 1, \dots, m$ so that Ψ is obtained from Ψ' by juxtaposition of each disk ψ_i at the vertex \mathbf{x}'_i . Let $\text{Polygons}_{\{1, \dots, m\}}$ denote the set of equivalence classes of such m -gons. We may thus re-state Proposition 3.9 of [GW10] as follows.

Proposition 2.1. *There is a one to one map*

$$\mathfrak{s}_H : \text{Polygons}_{\{1, \dots, m\}} \longrightarrow \text{Spin}^c(W_H)$$

so that for any $\Psi \in \pi_2(\mathbf{x}_1, \dots, \mathbf{x}_m)$, we have $\mathfrak{s}_H([\Psi])|_{M_{i, i+1}} = \mathfrak{s}(\mathbf{x}_i)$ for any $i = 1, \dots, m$.

For every index set

$$I = \{i_1 < \cdots < i_p\} \subset \{1, \dots, m\}$$

with $|I| \geq 3$ we may consider the cobordism W_I which corresponds to the compression of $W_H - \coprod_{i \notin I} (U_i \times e_i)$ along the edges $\Sigma \times e_i \subset \Sigma \times \mathbb{D}_m$ with $i \notin I$. Thus, W_I is represented by the Heegaard diagram $H_I = (\Sigma, \alpha^{i_1}, \dots, \alpha^{i_p}, \mathbf{z})$. Let

$$r_I : \text{Spin}^c(W_H) \rightarrow \text{Spin}^c(W_I).$$

be the corresponding restriction map. Denote $\mathfrak{s}_I = r_I(\mathfrak{s})$ for any $\mathfrak{s} \in \text{Spin}^c(W_H)$.

2.5. \mathbb{A} -diagrams and holomorphic polygon maps. Let \mathbb{A} be a commutative algebra over \mathbb{F} and $H = (\Sigma, \alpha^1, \dots, \alpha^m, \mathbf{z})$ be a balanced Heegaard diagram as before. Consider a map $\mathbf{u} : \mathbf{z} \rightarrow \mathbb{A}$. We will denote $\mathbf{u}(z_i)$ by \mathbf{u}_i . For any 2-chain \mathcal{D} on Σ with $\partial \mathcal{D}$ on $\alpha^1 \cup \cdots \cup \alpha^m$ we define $\mathbf{u}(\mathcal{D})$ as in Equation (1). Suppose $\Sigma \setminus \alpha^i = \coprod_{j=1}^{m^i} A_j^i$. Then, as before, \mathbf{u} is called an \mathbb{A} -coloring for H if the following are satisfied:

- (1) For any $i, j \in \{1, \dots, m\}$ we have $\sum_{k=1}^{m^i} \mathbf{u}(A_k^i) = \sum_{l=1}^{m^j} \mathbf{u}(A_l^j)$.
- (2) If A_j^i is not a punctured sphere, then $\mathbf{u}(A_j^i) = 0$.

Definition 2.6. Let the balanced Heegaard diagram $H = (\Sigma, \alpha^1, \dots, \alpha^m, \mathbf{z})$, the \mathbb{A} -coloring $\mathbf{u} : \mathbf{z} \rightarrow \mathbb{A}$ and Spin^c structure $\mathfrak{s} \in \text{Spin}^c(W_H)$ be as above. We call

$$\mathcal{H} = (\Sigma, \alpha^1, \dots, \alpha^m, \mathbf{u} : \mathbf{z} \rightarrow \mathbb{A}, \mathfrak{s})$$

an \mathbb{A} -diagram if it is \mathfrak{s} -admissible, i.e. if the following admissibility condition is satisfied. For every index set $I = \{i_1 < \cdots < i_p\}$ and every doubly periodic domain

$$\mathcal{P} = \mathcal{P}_{i_1 i_2} + \mathcal{P}_{i_2 i_3} + \cdots + \mathcal{P}_{i_p i_1}$$

with \mathcal{P}_{ij} a periodic domain on $(\Sigma, \boldsymbol{\alpha}^i, \boldsymbol{\alpha}^j, \mathbf{z})$, the following is true. If

$$\sum_{j=1}^p \left\langle c_1(\mathfrak{s}_{i_j i_{j+1}}), H(\mathcal{P}_{i_j i_{j+1}}) \right\rangle = 0$$

then either $\mathbf{u}(\mathcal{P}) = 0$ in \mathbb{A} or the coefficient of the domain \mathcal{P} at some point w is negative. Here, \mathfrak{s}_{ij} is the Spin^c structure on the 3-manifold M_{ij} (corresponding to $(\Sigma, \boldsymbol{\alpha}^i, \boldsymbol{\alpha}^j, \mathbf{z})$) which is determined by \mathfrak{s} .

Note that the admissibility condition only depends on the restrictions \mathfrak{s}_{ij} of \mathfrak{s} . In particular, for every family \mathfrak{T} of Spin^c structures with the same restrictions \mathfrak{s}_{ij} , we can speak of \mathbb{A} -diagrams

$$(\Sigma, \boldsymbol{\alpha}^1, \dots, \boldsymbol{\alpha}^m, \mathbf{u} : \mathbf{z} \rightarrow \mathbb{A}, \mathfrak{T}).$$

Let $\mathcal{H} = (\Sigma, \boldsymbol{\alpha}^1, \dots, \boldsymbol{\alpha}^m, \mathbf{u}, \mathfrak{s})$ be an \mathbb{A} -diagram and choose an appropriate translation invariant family of generic almost complex structure $J = \{J_z\}_{z \in \mathbb{D}_m}$. For every pair of indices $i < j$ we may thus define the chain complex $\text{CF}_J(\Sigma, \boldsymbol{\alpha}^i, \boldsymbol{\alpha}^j, \mathbf{u}, \mathfrak{s}_{ij})$. Associated with any subset

$$I = \{i_1 < \dots < i_p\} \subset \{1, \dots, m\}$$

of indices, we may then define a holomorphic polygon map

$$\begin{aligned} \mathfrak{f}_I : \bigotimes_{j=1}^{p-1} \text{CF}_J(\Sigma, \boldsymbol{\alpha}^{i_j}, \boldsymbol{\alpha}^{i_{j+1}}, \mathbf{u}, \mathfrak{s}_{i_j i_{j+1}}) &\longrightarrow \text{CF}_J(\Sigma, \boldsymbol{\alpha}^{i_1}, \boldsymbol{\alpha}^{i_p}, \mathbf{u}, \mathfrak{s}_{i_1 i_p}). \\ \mathfrak{f}_I(\mathbf{x}_1 \otimes \mathbf{x}_2 \otimes \dots \otimes \mathbf{x}_{p-1}) &:= \sum_{\substack{\mathbf{x}_p \in \mathbb{T}_{i_1} \cap \mathbb{T}_{i_p} \\ \mathfrak{s}(\mathbf{x}_p) = \mathfrak{s}_{i_1 i_p}}} \sum_{\substack{\Psi \in \pi_2(\mathbf{x}_1, \mathbf{x}_2, \dots, \mathbf{x}_p) \\ \mu(\Psi) = 3-p \\ [\Psi] = \mathfrak{s}_I}} (\mathfrak{m}(\Psi) \mathbf{u}(\Psi)) \cdot \mathbf{x}_p \end{aligned}$$

where $\mu(\Psi)$ denotes the Maslov index of the polygon class Ψ and $\mathfrak{m}(\Psi)$ is the count of points in $\mathcal{M}(\Psi)$ modulo 2.

3. TANGLE COMPLEX AND THE ISSUE OF NATURALITY

In this section we address the issue of naturality in the sense of [JT] for the construction of [AE15]. More precisely, we strengthen our result in [AE15] and show that for any \mathbb{A} -module \mathbb{M} , $\mathrm{HF}^{\mathbb{M}}$ defines a functor from $\mathbb{A}\text{-Tang}$ (See Definition 1.4) to $\mathbb{A}\text{-Mod}$. For the most part, the argument of [JT] for the naturality of sutured Floer homology may be copied here without significant modifications. In fact, we need to go through the argument presented in Section 9 of [JT] and check that all statements remain valid, a task that is outlined in the present section.

3.1. Oriented graph of isotopy Heegaard diagrams. Let us fix a commutative algebra \mathbb{A} over \mathbb{F} and an \mathbb{A} -module \mathbb{M} as before. Consider an \mathbb{A} -tangle $\mathcal{T} = [M, T, \mathfrak{s}, \mathfrak{u}]$ and let $\mathcal{H} = (\Sigma, \alpha, \beta, \mathfrak{u}, \mathfrak{s})$ be a Heegaard diagram for \mathcal{T} . Any collection of pairwise disjoint circles on Σ (like α and β) is called an *attaching set*. Recall that each attaching set γ on the pointed surface (Σ, \mathfrak{z}) determines a tangle $(C[\gamma], T[\gamma])$ where $C[\gamma]$ is the compression body obtained from $\Sigma \times [0, 1]$ by attaching 2-handles along $\gamma \times \{1\}$ and $T[\gamma] = \mathfrak{z} \times [0, 1]$. Then, $\partial^- C[\gamma] = \Sigma \times \{0\} \cong \Sigma$ and $\partial^+ C[\gamma] \cong \Sigma[\gamma]$, where $\Sigma[\gamma]$ denotes the surface obtained by performing surgery on Σ along the curves in γ . Attaching sets γ and γ' on Σ are called *compression equivalent*, denoted by $\gamma \sim \gamma'$, if there is a diffeomorphism $d : (C[\gamma], T[\gamma]) \rightarrow (C[\gamma'], T[\gamma'])$ such that it is the identity on $(\Sigma, \mathfrak{z}) = (\partial^- C[\gamma], \partial^- T[\gamma]) = (\partial^- C[\gamma'], \partial^- T[\gamma'])$. This gives an equivalence relation which descends to the isotopy classes, denoted by $[\gamma]$, of attaching sets γ on Σ . If $\gamma \sim \gamma'$ then $[\gamma]$ and $[\gamma']$ are related by a sequence of handle slides, [JT, Lemma 2.11].

If for the attaching sets α' and β' we have $[\alpha] = [\alpha']$ and $[\beta] = [\beta']$, and the \mathfrak{s} -admissibility condition is satisfied then $(\Sigma, \alpha', \beta', \mathfrak{u}, \mathfrak{s})$ is also a Heegaard diagram for \mathcal{T} . We may thus refer to the set of all such Heegaard diagrams as an *isotopy diagram* $(\Sigma, A, B, \mathfrak{u}, \mathfrak{s})$ for \mathcal{T} , where $A = [\alpha]$ and $B = [\beta]$.

The isotopy diagrams

$$\mathcal{H}_1 = (\Sigma_1, A_1, B_1, \mathfrak{u}_1 : \mathfrak{z}_1 \rightarrow \mathbb{A}, \mathfrak{s}_1) \quad \text{and} \quad \mathcal{H}_2 = (\Sigma_2, A_2, B_2, \mathfrak{u}_2 : \mathfrak{z}_2 \rightarrow \mathbb{A}, \mathfrak{s}_2)$$

are called α -equivalent if $\Sigma_1 = \Sigma_2$, $\mathfrak{z}_1 = \mathfrak{z}_2$, $\mathfrak{u}_1 = \mathfrak{u}_2$ and $B_1 = B_2$ while $A_1 \sim A_2$ and under the natural correspondence between Spin^c structures, $\mathfrak{s}_1 = \mathfrak{s}_2$. Similarly, we may define β -equivalence. Stabilization and destabilization also induce operations on isotopy diagrams. Furthermore, a *diffeomorphism* from \mathcal{H}_1 to \mathcal{H}_2 is an orientation preserving diffeomorphism $d : \Sigma_1 \rightarrow \Sigma_2$ such that $d(A_1) = A_2$, $d(B_1) = B_2$, $d(\mathfrak{z}_1) = \mathfrak{z}_2$, $d^* \mathfrak{s}_2 = \mathfrak{s}_1$.

Finally, we may define the oriented *graph* $\mathcal{G} = \mathcal{G}_{\mathcal{T}}$ (in the sense of [JT, Definition 2.21]) as follows. The vertices of \mathcal{G} are isotopy diagrams for \mathcal{T} and for any two vertices \mathcal{H}_1 and \mathcal{H}_2 , the set of edges connecting \mathcal{H}_1 to \mathcal{H}_2 , denoted by $\mathcal{G}(\mathcal{H}_1, \mathcal{H}_2)$, is a union of four sets

$$\mathcal{G}(\mathcal{H}_1, \mathcal{H}_2) = \mathcal{G}_{\alpha}(\mathcal{H}_1, \mathcal{H}_2) \amalg \mathcal{G}_{\beta}(\mathcal{H}_1, \mathcal{H}_2) \amalg \mathcal{G}_{\mathrm{stab}}(\mathcal{H}_1, \mathcal{H}_2) \amalg \mathcal{G}_{\mathrm{diff}}(\mathcal{H}_1, \mathcal{H}_2),$$

defined as follows. The set $\mathcal{G}_{\alpha}(\mathcal{H}_1, \mathcal{H}_2)$ (or $\mathcal{G}_{\beta}(\mathcal{H}_1, \mathcal{H}_2)$) consists of a single arrow if \mathcal{H}_1 and \mathcal{H}_2 are α -equivalent (or β -equivalent), otherwise it is empty. Similarly, $\mathcal{G}_{\mathrm{stab}}(\mathcal{H}_1, \mathcal{H}_2)$ consists of a single arrow if \mathcal{H}_2 is obtained from \mathcal{H}_1 by a stabilization or destabilization and $\mathcal{G}_{\mathrm{diff}}(\mathcal{H}_1, \mathcal{H}_2)$ contains an arrow corresponding to any diffeomorphism from \mathcal{H}_1 to \mathcal{H}_2 . Let $\mathcal{G}_{\alpha}, \mathcal{G}_{\beta}, \mathcal{G}_{\mathrm{stab}}$ and $\mathcal{G}_{\mathrm{diff}}$ denote the corresponding sub-graphs of \mathcal{G} . The sub-graphs $\mathcal{G}_{\alpha}, \mathcal{G}_{\beta}$ and $\mathcal{G}_{\mathrm{diff}}$ are in fact categories when endowed with the obvious compositions. The graph \mathcal{G} is connected as an oriented graph.

3.2. Special Heegaard diagrams. A Heegaard diagram $H = (\Sigma, \alpha, \beta, \mathfrak{z})$ is called *special* if $\alpha \sim \beta$, i.e. α is compression equivalent to β . Any special Heegaard diagram determines a balanced tangle (M, T) that is obtained from a product tangle by applying surgeries on ℓ 0-dimensional spheres, where $\ell = |\alpha| = |\beta|$. Furthermore, if a balanced tangle (M, T) has a special Heegaard diagram then $\mathrm{HF}(M, T, \mathfrak{s}) = 0$ for any *non-torsion* class $\mathfrak{s} \in \mathrm{Spin}^c(M)$. Recall that a Spin^c class $\mathfrak{s} \in \mathrm{Spin}^c(M)$ is called *torsion* if $\mathfrak{s} = [\underline{\mathfrak{s}}]$ for a torsion relative Spin^c class $\underline{\mathfrak{s}} \in \mathrm{Spin}^c(M, T)$ i.e. $c_1(\underline{\mathfrak{s}}) = 0$ as an element of $H^2(X, \mathbb{Z})$ for $X = M - \mathrm{nd}(T)$.

Associated with every $z_i \in \mathfrak{z} = \{z_1, \dots, z_{\kappa}\}$, let μ_i denote a small simple closed curve which is the boundary of a small disk around $z_i \in \Sigma$. The torsion relative Spin^c structures corresponding to

a special Heegaard diagram are related to each other by adding integer multiples of the cohomology classes $\text{PD}[\mu_i] \in \text{H}^2(M, T; \mathbb{Z})$, for $i = 1, \dots, \kappa$. In fact, the torsion relative Spin^c structures $\underline{\mathfrak{s}} \in \text{Spin}^c(M, T)$ with the property that $\text{HF}(M, T, \underline{\mathfrak{s}})$ is non-zero form a cone, in the sense that every such relative Spin^c structure $\underline{\mathfrak{s}}$ is of the form

$$\underline{\mathfrak{s}} = \underline{\mathfrak{s}}_0 + \sum_{i=1}^{\kappa} a_i \text{PD}[\mu_i], \quad \text{where } a_1, \dots, a_{\kappa} \in \mathbb{Z}^{\geq 0}.$$

The relative Spin^c structure $\underline{\mathfrak{s}}_0 \in \text{Spin}^c(M, T)$ is thus uniquely associated with our special Heegaard diagram, and is called its *distinguished* (torsion) relative Spin^c structure for the special Heegaard diagram H .

Fix a special Heegaard diagram $H = (\Sigma, \boldsymbol{\alpha}, \boldsymbol{\beta}, \mathbf{z})$ as above, and let (M, T) be the corresponding balanced tangle. Further, assume that for the torsion Spin^c class $\mathfrak{s}_0 \in \text{Spin}^c(M, T)$ the diagram H is \mathfrak{s}_0 -admissible. If $\mathbf{z} = \{z_1, \dots, z_{\kappa}\}$, then $\mathbb{A}_T = \frac{\mathbb{Z}[u_1, \dots, u_{\kappa}]}{\mathcal{I}}$ where u_i is the variable corresponding to z_i and \mathcal{I} is the ideal of relations. Note that \mathcal{I} is generated by monomials corresponding to connected components of $\Sigma \setminus \boldsymbol{\alpha}$ (or $\Sigma \setminus \boldsymbol{\beta}$) that are not punctured spheres.

Consider $a \cdot \mathbf{x}, b \cdot \mathbf{y} \in \text{CF}(M, T, \underline{\mathfrak{s}})$ such that $\mathbf{x}, \mathbf{y} \in \mathbb{T}_{\alpha} \cap \mathbb{T}_{\beta}$, $\underline{\mathfrak{s}} \in \text{Spin}^c(M, T)$ is torsion and

$$a = u_1^{a_1} \cdots u_{\kappa}^{a_{\kappa}} \quad \text{and} \quad b = u_1^{b_1} \cdots u_{\kappa}^{b_{\kappa}}$$

are non-zero monomials in \mathbb{A}_T . Then, we say a homotopy disk $\phi \in \pi_2(\mathbf{x}, \mathbf{y})$ connects $a \cdot \mathbf{x}$ to $b \cdot \mathbf{y}$ if $a_i + n_{z_i}(\phi) = b_i$ for any $i = 1, \dots, \kappa$. We define $\text{gr}(a \cdot \mathbf{x}, b \cdot \mathbf{y}) = \mu(\phi)$ for a homotopy disk $\phi \in \pi_2(\mathbf{x}, \mathbf{y})$ connecting $a \cdot \mathbf{x}$ to $b \cdot \mathbf{y}$.

Lemma 3.1. *The map gr is well-defined and induces a relative \mathbb{Z} -grading on*

$$\text{CF}(M, T, \underline{\mathfrak{s}}) = \text{CF}(\Sigma, \boldsymbol{\alpha}, \boldsymbol{\beta}, \mathbf{z}, \underline{\mathfrak{s}}),$$

for every torsion relative Spin^c structure $\underline{\mathfrak{s}} \in \text{Spin}^c(M, T)$. Furthermore, the subgroup of $\text{HF}(M, T, \underline{\mathfrak{s}}_0)$ in top homological grading is isomorphic to \mathbb{F} for the distinguished relative Spin^c structure $\underline{\mathfrak{s}}_0 \in \text{Spin}^c(M, T)$.

Proof. Let $\phi_1, \phi_2 \in \pi_2(\mathbf{x}, \mathbf{y})$ be homotopy disks connecting $a \cdot \mathbf{x}$ to $b \cdot \mathbf{y}$. Then, $\mathcal{P} = \phi_1 - \phi_2$ would be a periodic domain such that $n_{z_i}(\mathcal{P}) = 0$ for any $i = 1, \dots, \kappa$. Hence,

$$\mu(\phi_1) - \mu(\phi_2) = \mu(\mathcal{P}) = \langle c_1(\underline{\mathfrak{s}}), H(\mathcal{P}) \rangle = 0.$$

In particular, gr is well-defined. For the second part, it is not hard to show that $\text{HF}(M, T, \underline{\mathfrak{s}}_0)$ is invariant up to isomorphism in each relative grading. So the discussions in Section 6.2 of [AE15] implies that the subgroup with the top grading is isomorphic to \mathbb{F} . \square

Hence, the homology group in the top grading has a well-defined generator up to sign, called *top generator*, in the summand $\text{HF}(M, T, \underline{\mathfrak{s}}_0)$ of $\text{HF}(M, T, \mathfrak{s}_0)$, where $\underline{\mathfrak{s}}_0 \in \text{Spin}^c(M, T)$ is the distinguished torsion Spin^c structure and $\mathfrak{s}_0 = [\underline{\mathfrak{s}}_0]$ is its image in $\text{Spin}^c(M)$. This generator is denoted by $\Theta_{\alpha\beta}$.

3.3. Weak Heegaard invariance. In this section, we check that $\text{HF}^{\mathbb{M}}$ is a *weak Heegaard invariant* i.e. for any \mathbb{A} -tangle \mathcal{T} , we construct a well-defined \mathbb{A} -module $\text{HF}^{\mathbb{M}}(\mathcal{H})$ for every vertex \mathcal{H} of $\mathcal{G}_{\mathcal{T}}$ and associate an isomorphism to any edge of $\mathcal{G}_{\mathcal{T}}$.

Consider an \mathbb{A} -diagram $\mathcal{H} = (\Sigma, \boldsymbol{\alpha}, \boldsymbol{\beta}, \mathbf{u}, \mathfrak{s})$ and a complex structure \mathfrak{j} on Σ . Recall that any generic path J_s of perturbations of $\text{Sym}^{\ell}(\mathfrak{j})$ gives a chain complex

$$\text{CF}_{J_s}(\Sigma, \boldsymbol{\alpha}, \boldsymbol{\beta}, \mathbf{u}, \mathfrak{s}),$$

generated by the intersection points $\mathbf{x} \in \mathbb{T}_{\alpha} \cap \mathbb{T}_{\beta}$ with $\mathfrak{s}(\mathbf{x}) = \mathfrak{s}$, where $\ell = |\boldsymbol{\alpha}| = |\boldsymbol{\beta}|$. We will usually drop the complex structure \mathfrak{j} on Σ from the notation. Given two different choices (\mathfrak{j}, J_s) and (\mathfrak{j}', J'_s) , the proof of Lemma 2.11 from [OS06] gives an isomorphism of \mathbb{A} -modules

$$\Phi_{J_s \rightarrow J'_s} : \text{HF}_{J_s}^{\mathbb{M}}(\Sigma, \boldsymbol{\alpha}, \boldsymbol{\beta}, \mathbf{u}, \mathfrak{s}) \longrightarrow \text{HF}_{J'_s}^{\mathbb{M}}(\Sigma, \boldsymbol{\alpha}, \boldsymbol{\beta}, \mathbf{u}, \mathfrak{s}).$$

for any \mathbb{A} -module \mathbb{M} . Moreover,

$$\Phi_{J'_s \rightarrow J''_s} \circ \Phi_{J_s \rightarrow J'_s} = \Phi_{J_s \rightarrow J''_s}.$$

One may thus define

$$\mathrm{HF}^{\mathbb{M}}(\Sigma, \alpha, \beta, \mathbf{u}, \mathfrak{s}) = \frac{\coprod_{J_s} \mathrm{HF}_{J_s}^{\mathbb{M}}(\Sigma, \alpha, \beta, \mathbf{u}, \mathfrak{s})}{\sim}$$

where $x \sim y$ if $y = \Phi_{J_s \rightarrow J'_s}(x)$ for some J_s and J'_s . Since we will face several equivalence relations in the definition of $\mathrm{HF}^{\mathbb{M}}(\mathcal{T})$ we will abuse the notation and denote all of them by \sim , leaving it to the reader to make the distinctions.

Let us assume that

$$\mathcal{H} = (\Sigma, \alpha, \beta, \beta', \mathbf{u}, \mathfrak{t})$$

is an \mathbb{A} -diagram and $\beta \sim \beta'$. Furthermore, suppose that the restriction of \mathfrak{t} to $M_{\beta\beta'}$ is the torsion Spin^c structure \mathfrak{s}_0 , which was discussed in the previous subsection. With this restriction in place, \mathfrak{t} is determined by its restriction \mathfrak{s} to $M_{\alpha\beta}$, and the induced Spin^c structure on $M_{\alpha\beta'}$ is in correspondence with \mathfrak{s} under the natural identification of $M_{\alpha\beta}$ with $M_{\alpha\beta'}$. We will thus abuse the notation and denote the above \mathbb{A} -diagram by

$$(\Sigma, \alpha, \beta, \beta', \mathbf{u}, \mathfrak{s})$$

implying that the above restrictions on \mathfrak{t} are imposed. Then, using the top generator $\Theta_{\beta\beta'}$ we may define an isomorphism

$$\Phi_{\beta \rightarrow \beta'}^{\alpha} : \mathrm{HF}^{\mathbb{M}}(\Sigma, \alpha, \beta, \mathbf{u}, \mathfrak{s}) \longrightarrow \mathrm{HF}^{\mathbb{M}}(\Sigma, \alpha, \beta', \mathbf{u}, \mathfrak{s}).$$

The arguments in the sequence of lemmas preceding Proposition 9.9 in [JT] may then be copied in our setup to show that if $(\Sigma, \alpha, \beta, \mathbf{u}, \mathfrak{s})$ and $(\Sigma, \alpha, \beta', \mathbf{u}, \mathfrak{s})$ are Heegaard diagrams for \mathcal{T} , one may define a chain map and a well-defined induced isomorphism

$$\Phi_{\beta \rightarrow \beta'}^{\alpha} : \mathrm{HF}^{\mathbb{M}}(\Sigma, \alpha, \beta, \mathbf{u}, \mathfrak{s}) \longrightarrow \mathrm{HF}^{\mathbb{M}}(\Sigma, \alpha, \beta', \mathbf{u}, \mathfrak{s}),$$

using the top generators and a detour to admissible triple diagrams (note that the above assumptions do not imply that the $(\Sigma, \alpha, \beta, \beta', \mathbf{u}, \mathfrak{s})$ is an \mathbb{A} -diagram). Furthermore, if $(\Sigma, \alpha, \beta'', \mathbf{u}, \mathfrak{s})$ is a third Heegaard diagram for \mathcal{T} so that $\beta \sim \beta' \sim \beta''$, we get

$$(2) \quad \Phi_{\beta' \rightarrow \beta''}^{\alpha} \circ \Phi_{\beta \rightarrow \beta'}^{\alpha} = \Phi_{\beta \rightarrow \beta''}^{\alpha}.$$

Similarly, one may define $\Phi_{\beta \rightarrow \alpha'}^{\alpha}$. If $(\Sigma, \alpha, \beta, \mathbf{u}, \mathfrak{s})$, $(\Sigma, \alpha', \beta, \mathbf{u}, \mathfrak{s})$, $(\Sigma, \alpha, \beta', \mathbf{u}, \mathfrak{s})$ and $(\Sigma, \alpha', \beta', \mathbf{u}, \mathfrak{s})$ are Heegaard diagrams for \mathcal{T} so that $\alpha \sim \alpha'$ and $\beta \sim \beta'$, one may define

$$\Phi_{\beta \rightarrow \beta'}^{\alpha \rightarrow \alpha'} = \Phi_{\beta \rightarrow \beta'}^{\alpha'} \circ \Phi_{\beta \rightarrow \alpha'}^{\alpha} = \Phi_{\beta' \rightarrow \alpha'}^{\alpha \rightarrow \alpha'} \circ \Phi_{\beta \rightarrow \beta'}^{\alpha}.$$

It follows from [JT, Lemma 9.11] that these isomorphisms satisfy

$$(3) \quad \Phi_{\beta' \rightarrow \beta''}^{\alpha' \rightarrow \alpha''} \circ \Phi_{\beta \rightarrow \beta'}^{\alpha \rightarrow \alpha'} = \Phi_{\beta \rightarrow \beta''}^{\alpha \rightarrow \alpha''} \quad \text{and} \quad \Phi_{\beta \rightarrow \beta'}^{\alpha \rightarrow \alpha'} = \Phi_{\beta \rightarrow \beta}^{\alpha} = \Phi_{\beta \rightarrow \beta}^{\alpha \rightarrow \alpha} = \mathrm{Id}_{\mathrm{HF}^{\mathbb{M}}(\Sigma, \alpha, \beta, \mathbf{u}, \mathfrak{s})}.$$

These isomorphisms may be used to construct a well-defined \mathbb{A} -module $\mathrm{HF}^{\mathbb{M}}(\mathcal{H})$ for every vertex \mathcal{H} of $\mathcal{G}_{\mathcal{T}}$ and associate isomorphisms to edges of \mathcal{G}_{α} and \mathcal{G}_{β} , as follows.

Given an isotopy diagram $\mathcal{H} = (\Sigma, A, B, \mathbf{u}, \mathfrak{s})$ for \mathcal{T} , we denote by $\mathcal{M}_{\mathcal{H}}$ the set of all Heegaard diagrams corresponding to \mathcal{H} , and we let

$$\mathrm{HF}^{\mathbb{M}}(\mathcal{H}) = \frac{\coprod_{(\Sigma, \alpha, \beta, \mathbf{u}, \mathfrak{s}) \in \mathcal{M}_{\mathcal{H}}} \mathrm{HF}^{\mathbb{M}}(\Sigma, \alpha, \beta, \mathbf{u}, \mathfrak{s})}{\sim}$$

where the generators $x \in \mathrm{HF}^{\mathbb{M}}(\Sigma, \alpha, \beta, \mathbf{u}, \mathfrak{s})$ and $x' \in \mathrm{HF}^{\mathbb{M}}(\Sigma, \alpha', \beta', \mathbf{u}, \mathfrak{s})$ are equivalent if and only if $x' = \Phi_{\beta \rightarrow \beta'}^{\alpha \rightarrow \alpha'}(x)$.

Suppose $\mathcal{H} = (\Sigma, A, B, \mathbf{u}, \mathfrak{s})$ and $\mathcal{H}' = (\Sigma, A, B', \mathbf{u}, \mathfrak{s})$ are β -equivalent. Pick representatives $(\Sigma, \alpha, \beta, \mathbf{u}, \mathfrak{s})$ and $(\Sigma, \alpha, \beta', \mathbf{u}, \mathfrak{s})$ of \mathcal{H} and \mathcal{H}' , respectively. The formal proof of [JT, Lemma 9.17] then implies that $\Phi_{\beta \rightarrow \beta'}^{\alpha}$ descends to a well-defined isomorphism

$$\Phi_{B \rightarrow B'}^A : \mathrm{HF}^{\mathbb{M}}(\mathcal{H}) \longrightarrow \mathrm{HF}^{\mathbb{M}}(\mathcal{H}').$$

Similarly, an α -equivalence from $\mathcal{H} = (\Sigma, A, B, \mathbf{u}, \mathfrak{s})$ to $\mathcal{H}' = (\Sigma, A', B, \mathbf{u}, \mathfrak{s})$ gives a well-defined isomorphism

$$\Phi_B^{A \rightarrow A'} : \mathrm{HF}^{\mathbb{M}}(\mathcal{H}) \longrightarrow \mathrm{HF}^{\mathbb{M}}(\mathcal{H}').$$

Consider an edge of $\mathcal{G}_{\mathrm{diff}}$ i.e. a diffeomorphism $d : \mathcal{H} \rightarrow \mathcal{H}'$. It gives a correspondence between complex structures, which in turn gives the isomorphism

$$d_* : \mathrm{HF}^{\mathbb{M}}(\mathcal{H}) \longrightarrow \mathrm{HF}^{\mathbb{M}}(\mathcal{H}'),$$

c.f. [JT, Definition 9.19 and Lemma 9.20].

Finally, if the Heegaard diagram $(\Sigma', \boldsymbol{\alpha}', \boldsymbol{\beta}', \mathbf{u}', \mathfrak{s}')$ is obtained from $(\Sigma, \boldsymbol{\alpha}, \boldsymbol{\beta}, \mathbf{u}, \mathfrak{s})$ by stabilization, there is a correspondence between the homotopy classes of disks on the two sides. Furthermore, for suitable almost complex structures on the two diagrams, there is an isomorphism of chain complexes associated with the two diagrams. If \mathcal{H} and \mathcal{H}' denote the isotopy diagrams corresponding to the above two Heegaard diagrams for \mathcal{T} , [JT, Lemma 9.21] (which is basically [OS06, Lemma 2.15]) may be used to construct the isomorphism

$$\sigma_{\mathcal{H} \rightarrow \mathcal{H}'} : \mathrm{HF}^{\mathbb{M}}(\mathcal{H}) \longrightarrow \mathrm{HF}^{\mathbb{M}}(\mathcal{H}').$$

Hence, $\mathrm{HF}^{\mathbb{M}}$ is a weak Heegaard invariant, and the above considerations reprove the invariance of the quasi-isomorphism type of the chain complex $\mathrm{CF}^{\mathbb{M}}(\mathcal{T})$.

3.4. Strong Heegaard invariance. The weak Heegaard invariant $\mathrm{HF}^{\mathbb{M}}$ is a *strong Heegaard invariant* if it satisfies the following axioms, [JT]:

- (1) **Factoriality:** The restriction of $\mathrm{HF}^{\mathbb{M}}$ to the categories $\mathcal{G}_\alpha, \mathcal{G}_\beta$ and $\mathcal{G}_{\mathrm{diff}}$ is a functor to the category $\mathbb{A}\text{-Mod}$ of \mathbb{A} -modules. Moreover, if $\sigma : \mathcal{H} \rightarrow \mathcal{H}'$ is a stabilization and $\sigma' : \mathcal{H}' \rightarrow \mathcal{H}$ is the corresponding destabilization then $\mathrm{HF}^{\mathbb{M}}(\sigma') = \mathrm{HF}^{\mathbb{M}}(\sigma)^{-1}$.
- (2) **Commutativity:** For every distinguished rectangle

$$\begin{array}{ccc} \mathcal{H}_1 & \xrightarrow{e_1} & \mathcal{H}_2 \\ e_2 \downarrow & & \downarrow e_3 \\ \mathcal{H}_3 & \xrightarrow{e_4} & \mathcal{H}_4 \end{array}$$

in \mathcal{G} we have $\mathrm{HF}^{\mathbb{M}}(e_3) \circ \mathrm{HF}^{\mathbb{M}}(e_1) = \mathrm{HF}^{\mathbb{M}}(e_4) \circ \mathrm{HF}^{\mathbb{M}}(e_2)$, where $\mathrm{HF}^{\mathbb{M}}(e_i)$ denotes the associated isomorphism to e_i . Here, distinguished rectangles are the rectangles of the above type such that one of the following is the case:

- The horizontal arrows are α -equivalences while the vertical arrows are β -equivalences.
 - Both horizontal arrows are α - or β -equivalences, while the vertical arrows are stabilizations.
 - Both horizontal arrows are α - or β -equivalences, while the vertical arrows are diffeomorphisms with the same restriction on the surface.
 - The square corresponds to the two possible ways of performing disjoint stabilizations.
 - The horizontal arrows are diffeomorphisms and the vertical arrows are stabilizations which correspond to one another via the diffeomorphisms.
- (3) **Continuity:** If \mathcal{H} is a vertex of \mathcal{G} and $d \in \mathcal{G}_{\mathrm{diff}}(\mathcal{H}, \mathcal{H})$ is a diffeomorphism isotopic to the identity, then $\mathrm{HF}^{\mathbb{M}}(d) = \mathrm{Id}_{\mathrm{HF}^{\mathbb{M}}(\mathcal{H})}$.
 - (4) **Handleswap invariance:** For every simple handle swap

$$\begin{array}{ccc} & \mathcal{H}_1 & \\ & \uparrow & \searrow e_1 \\ e_3 \downarrow & & \\ & \mathcal{H}_3 & \xleftarrow{e_2} \mathcal{H}_2 \end{array}$$

in the sense of [JT, Definition 2.32] in \mathcal{G} we have

$$\mathrm{HF}^{\mathbb{M}}(e_3) \circ \mathrm{HF}^{\mathbb{M}}(e_2) \circ \mathrm{HF}^{\mathbb{M}}(e_1) = \mathrm{Id}_{\mathrm{HF}^{\mathbb{M}}(\mathcal{H}_1)}.$$

Functoriality follows from equations (2) and (3) for α - and β -equivalences, and is a consequence of the definition for the diffeomorphisms. Moreover, the equality $\mathrm{HF}_{\mathbb{M}}(\sigma') = \mathrm{HF}_{\mathbb{M}}(\sigma)^{-1}$ is a consequence of the definition.

Our earlier considerations proves the axiom of commutativity for the first three types of distinguished rectangles. The commutativity of a diagram of the fourth type is satisfied in the level of chain complexes if the \mathbb{A} -diagrams (representing \mathcal{H}_i), and the complex structures on the surfaces are chosen correctly. Similarly and following the argument of [JT, Subsection 9.2], for suitable \mathbb{A} -diagrams representing the isotopy diagrams \mathcal{H}_i and the correct choice of almost complex structures, the commutativity of the diagrams of the fifth type is satisfied in the level of chain complexes.

One may then copy the proof of [JT, Proposition 9.23] and show that if for the \mathbb{A} -diagram $(\Sigma, \alpha, \beta, \mathbf{u}, \mathfrak{s})$ the map $d : \Sigma \rightarrow \Sigma$ is isotopic to identity, then $d_* = \Phi_{\beta \rightarrow \beta'}^{\alpha \rightarrow \alpha'}$, where $\alpha' = d(\alpha)$ and $\beta' = d(\beta)$. Thus, it follows from our definition of $\mathrm{HF}_{\mathbb{M}}(\mathcal{H})$ that the induced isomorphism $\mathrm{HF}^{\mathbb{M}}(d)$ is identity. This completes the proof of continuity.

Finally, let $\mathcal{H}_1, \mathcal{H}_2$ and \mathcal{H}_3 denote the isotopy diagrams corresponding to a handleswap. Choose \mathbb{A} -diagrams $(\Sigma, \alpha_i, \beta_i, \mathbf{u}, \mathfrak{s}_i)$ representing \mathcal{H}_i , $i = 1, 2, 3$. The argument given for handleswap invariance in Subsection 9.3 of [JT] regards the region corresponding to the handleswap in the aforementioned Heegaard diagrams as a genus 2 subsurface Σ^0 of the connected sum of Σ^0 with another surface Σ^1 , such that the Heegaard diagrams are identical on Σ^1 , all markings in \mathbf{z} lie on Σ^1 , and two curves from each one of the attaching sets α_i and β_i are on Σ^0 . It is implied by [JT, Lemma 9.25 and Lemma 9.28] (which stay correct in our more general framework) that every triangle class which contributes to $\mathrm{HF}^{\mathbb{M}}(e_1)$ or $\mathrm{HF}^{\mathbb{M}}(e_2)$ may be decomposed as a disjoint union of a triangle class on Σ^1 which does not pass through the connected sum region and a small triangle class on Σ^0 . The proof of Proposition 9.24 from [JT] thus goes through without difficulty, completing the proof of handleswap invariance.

Let \mathfrak{h} denote an oriented path in $\mathcal{G}_{\mathcal{T}}$ from the isotopy diagram \mathcal{H} to the isotopy diagram \mathcal{H}' . Composing the isomorphisms corresponding to the edges in \mathfrak{h} we obtain an isomorphism

$$\mathrm{HF}^{\mathbb{M}}(\mathfrak{h}) : \mathrm{HF}^{\mathbb{M}}(\mathcal{H}) \longrightarrow \mathrm{HF}^{\mathbb{M}}(\mathcal{H}').$$

If \mathfrak{h} and \mathfrak{h}' are different oriented paths from \mathcal{H} to \mathcal{H}' , [JT, Theorem 2.39], implies that $\mathrm{HF}^{\mathbb{M}}(\mathfrak{h}) = \mathrm{HF}^{\mathbb{M}}(\mathfrak{h}')$, since $\mathrm{HF}^{\mathbb{M}}$ is a strong Heegaard invariant. In other words, associated with the vertices \mathcal{H} and \mathcal{H}' of $\mathcal{G}_{\mathcal{T}}$ there is a well-defined isomorphism

$$\mathrm{HF}_{\mathcal{H} \rightarrow \mathcal{H}'}^{\mathbb{M}} : \mathrm{HF}^{\mathbb{M}}(\mathcal{H}) \longrightarrow \mathrm{HF}^{\mathbb{M}}(\mathcal{H}').$$

It is clear that

$$\mathrm{HF}_{\mathcal{H}' \rightarrow \mathcal{H}''}^{\mathbb{M}} \circ \mathrm{HF}_{\mathcal{H} \rightarrow \mathcal{H}'}^{\mathbb{M}} = \mathrm{HF}_{\mathcal{H} \rightarrow \mathcal{H}''}^{\mathbb{M}}.$$

One may thus define

$$\mathrm{HF}^{\mathbb{M}}(\mathcal{T}) := \frac{\coprod_{\mathcal{H} \in |\mathcal{G}_{\mathcal{T}}|} \mathrm{HF}^{\mathbb{M}}(\mathcal{H})}{\sim},$$

where x is equivalent to y if $y = \mathrm{HF}_{\mathcal{H} \rightarrow \mathcal{H}'}^{\mathbb{M}}(x)$. Thus, associated with every \mathbb{A} -tangle \mathcal{T} and \mathbb{A} -module \mathbb{M} we obtain a well-defined \mathbb{A} -module $\mathrm{HF}^{\mathbb{M}}(\mathcal{T})$.

Let $d : \mathcal{T} = [M, T, \mathbf{u}, \mathfrak{s}] \rightarrow \mathcal{T}' = [M', T', \mathbf{u}', \mathfrak{s}']$ be a diffeomorphism of \mathbb{A} -tangles. Pick an isotopy diagram $\mathcal{H} = (\Sigma, A, B, \mathbf{u}, \mathfrak{s})$ for \mathcal{T} . The diffeomorphism d takes Σ to a surface Σ' in M' and the markings \mathbf{z} to a set \mathbf{z}' of markings such that $\mathbf{z}' = \Sigma' \cap T'$. Let $A' = d(A)$ and $B' = d(B)$. Furthermore, we obtain a Spin^c structure \mathfrak{s}' for $(\Sigma', A', B', \mathbf{z}')$ which corresponds to \mathfrak{s} . We may define $\mathbf{u}' : \mathbf{z}' \rightarrow \mathbb{A}$ as $\mathbf{u} \circ d^{-1}$. We thus obtain the isotopy diagram $\mathcal{H}' = d(\mathcal{H})$ for \mathcal{T}' . The isomorphism

$$\mathrm{HF}^{\mathbb{M}}(d) : \mathrm{HF}^{\mathbb{M}}(\mathcal{H}) \longrightarrow \mathrm{HF}^{\mathbb{M}}(\mathcal{H}')$$

associated with the diffeomorphism d from H to H' , induces a well-defined isomorphism

$$\mathrm{HF}^{\mathbb{M}}(d) : \mathrm{HF}^{\mathbb{M}}(\mathcal{T}) \longrightarrow \mathrm{HF}^{\mathbb{M}}(\mathcal{T}').$$

The above considerations imply the following theorem.

Theorem 3.2. *For every algebra \mathbb{A} over \mathbb{F} and every \mathbb{A} -module \mathbb{M} , assigning $\mathrm{HF}^{\mathbb{M}}(\mathcal{T})$ to the \mathbb{A} -tangle \mathcal{T} in $\mathbb{A}\text{-Tang}$ gives a functor*

$$\mathrm{HF}^{\mathbb{M}} : \mathbb{A}\text{-Tang} \longrightarrow \mathbb{A}\text{-Mod}.$$

3.5. The action of $\Lambda^*(H_1(M, \mathbb{Z})/\mathrm{Tors})$. As in the usual setup of the Heegaard Floer homology, there is a natural action of $\Lambda^*(H_1(M_{\mathcal{T}}, \mathbb{Z})/\mathrm{Tors})$ on $\mathrm{HF}^{\mathbb{M}}(\mathcal{T})$ as follows. Let us assume that $H = (\Sigma, \boldsymbol{\alpha}, \boldsymbol{\beta}, \mathbf{u} : \mathbf{z} \rightarrow \mathbb{A}, \mathfrak{s})$ is an \mathbb{A} -diagram for the \mathbb{A} -tangle $\mathcal{T} = [M, T, \mathbf{u}, \mathfrak{s}]$. First of all, as discussed in Subsection 2.4 of [OS04c], there is a homotopy long exact sequence

$$0 \longrightarrow \mathbb{Z} \longrightarrow \pi_1(\Omega(\mathbb{T}_{\alpha}, \mathbb{T}_{\beta})) \longrightarrow \pi_1(\mathbb{T}_{\alpha} \times \mathbb{T}_{\beta}) \longrightarrow \pi_1(\mathrm{Sym}^g(\Sigma)).$$

Here $\Omega(\mathbb{T}_{\alpha}, \mathbb{T}_{\beta})$ denotes the space of paths in $\mathrm{Sym}^g(\Sigma)$ joining \mathbb{T}_{α} to \mathbb{T}_{β} . Under the identification of $\pi_1(\mathrm{Sym}^g(\Sigma))$ with $H^1(\Sigma, \mathbb{Z})$, $\pi_1(\mathbb{T}_{\alpha})$ and $\pi_1(\mathbb{T}_{\beta})$ correspond to $H^1(C(\boldsymbol{\alpha}), \mathbb{Z})$ and $H^1(C(\boldsymbol{\beta}), \mathbb{Z})$, respectively. After comparing the above exact sequence with the cohomology long exact sequence for the decomposition $M = C(\boldsymbol{\alpha}) \cup_{\Sigma} C(\boldsymbol{\beta})$, we obtain the short exact sequence

$$0 \longrightarrow \mathbb{Z} \longrightarrow \pi_1(\Omega(\mathbb{T}_{\alpha}, \mathbb{T}_{\beta})) \longrightarrow H^1(M, \mathbb{Z}) \longrightarrow 0.$$

Applying $\mathrm{Hom}(-, \mathbb{Z})$ to the above short exact sequence we obtain

$$0 \longrightarrow H_1(M, \mathbb{Z})/\mathrm{Tors} \longrightarrow H^1(\Omega(\mathbb{T}_{\alpha}, \mathbb{T}_{\beta}), \mathbb{Z}) \longrightarrow \mathbb{Z}.$$

Every element $\zeta \in H_1(M, \mathbb{Z})/\mathrm{Tors}$ may thus be realized as an element of $H^1(\Omega(\mathbb{T}_{\alpha}, \mathbb{T}_{\beta}), \mathbb{Z})$, which is represented by a 1-cocycle $Z(\zeta) \in Z^1(\Omega(\mathbb{T}_{\alpha}, \mathbb{T}_{\beta}), \mathbb{Z})$ in the space of paths connecting $\mathbb{T}_{\alpha} \cap \mathbb{T}_{\beta}$. If $\phi \in \pi_2(\mathbf{x}, \mathbf{y})$ is the homotopy class of a Whitney disk, it may be viewed as an arc in $\Omega(\mathbb{T}_{\alpha}, \mathbb{T}_{\beta})$ which connects the constant path at \mathbf{x} to the constant path at \mathbf{y} . The evaluation of $Z(\zeta)$ over this path gives a value $n_{Z(\zeta)}(\phi)$. Correspondingly, we may define a map

$$\begin{aligned} A_{Z(\zeta)} &: \mathrm{CF}(\Sigma, \boldsymbol{\alpha}, \boldsymbol{\beta}, \mathbf{u}, \mathfrak{s}) \rightarrow \mathrm{CF}(\Sigma, \boldsymbol{\alpha}, \boldsymbol{\beta}, \mathbf{u}, \mathfrak{s}) \\ A_{Z(\zeta)}(\mathbf{x}) &:= \sum_{\substack{\mathbf{y} \in \mathbb{T}_{\alpha} \cap \mathbb{T}_{\beta} \\ \mathfrak{s}(\mathbf{y}) = \mathfrak{s}}} \sum_{\phi \in \pi_2^1(\mathbf{x}, \mathbf{y})} n_{Z(\zeta)}(\phi) \mathfrak{m}(\phi) \mathbf{u}(\phi) \mathbf{y}. \end{aligned}$$

The proof of [OS04c, Lemma 4.18] implies that $A_{Z(\zeta)}$ is a chain map and the proof of [OS04c, Lemma 4.19] implies that if $Z(\zeta)$ is a coboundary then $A_{Z(\zeta)}$ is chain homotopic to zero. The map induced by $A_{Z(\zeta)}$ on homology is thus independent of the choice of the cocycle $Z(\zeta)$, and may thus be represented by

$$A_{\zeta} : \mathrm{HF}^{\mathbb{M}}(\Sigma, \boldsymbol{\alpha}, \boldsymbol{\beta}, \mathbf{u}, \mathfrak{s}) \rightarrow \mathrm{HF}^{\mathbb{M}}(\Sigma, \boldsymbol{\alpha}, \boldsymbol{\beta}, \mathbf{u}, \mathfrak{s}).$$

The proof of [OS04c, Proposition 4.17] may then be copied to show that $A_{\zeta} \circ A_{\zeta} = 0$. Consequently, we obtain an action of the exterior algebra $\Lambda^*(H_1(M, \mathbb{Z})/\mathrm{Tors})$ on $\mathrm{HF}^{\mathbb{M}}(\Sigma, \boldsymbol{\alpha}, \boldsymbol{\beta}, \mathbf{u}, \mathfrak{s})$.

We may then follow the steps toward weak and strong Heegaard invariance of the functor $\mathrm{HF}^{\mathbb{M}}$, and observe that all the isomorphisms which correspond to the edges of the graph $\mathcal{G}_{\mathcal{T}}$ preserve the action of $\Lambda^*(H_1(M, \mathbb{Z})/\mathrm{Tors})$ constructed above. This observation implies the following proposition.

Proposition 3.3. *For every \mathbb{A} -tangle \mathcal{T} and every \mathbb{A} -module \mathbb{M} , there is a natural action of $\Lambda^*(H_1(M_{\mathcal{T}}, \mathbb{Z})/\mathrm{Tors})$ on $\mathrm{HF}^{\mathbb{M}}(\mathcal{T})$.*

4. PARAMETRIZED CERF DECOMPOSITION

4.1. Parametrized elementary cobordism. Let (M, T) be a balanced tangle. For $k = 0, 1, 2$, a framed k -sphere \mathbb{S} in (M, T) is an embedding of $S^k \times D^{3-k}$ in $M - T$. In other word, it is an embedded k -sphere $a(\mathbb{S}) = S^k \times \{0\}$, called attaching sphere, in $M - T$ together with a trivialization ν of its normal bundle. We will denote by

$$\mathcal{W}(\mathbb{S}) = (W(\mathbb{S}), F(\mathbb{S}))$$

the cobordism obtained by attaching a k -handle to $M \times [0, 1]$ along $\mathbb{S} \times \{1\}$ to construct $W(\mathbb{S})$ and setting $F(\mathbb{S}) = T \times [0, 1] \subset W(\mathbb{S})$. Thus $\mathcal{W}(\mathbb{S})$ is a cobordism from (M, T) to $(M(\mathbb{S}), T)$, where $M(\mathbb{S})$ is obtained by surgery on M along \mathbb{S} .

Similarly, a framed arc \mathbb{I} in (M, T) is an embedding of $D^2 \times D^1$ in M such that

$$\mathbb{I}^{-1}(T) = (\{x = 0\} \times \{-1\}) \amalg (\{x = 0\} \times \{1\}),$$

where (x, y) denotes the standard coordinate system on D^2 (as a subset of \mathbb{R}^2). Moreover, \mathbb{I} is called *orientation preserving* if the restriction of \mathbb{I} to

$$\{x = 0\} \times \{-1\} \amalg \{x = 0\} \times \{1\} \subset \partial(\{x = 0\} \times [-1, 1]),$$

which is equipped with the boundary orientation, is orientation preserving as a map to T . We think of \mathbb{I} as an embedded arc $a(\mathbb{I}) = \{0\} \times D^1$, called attaching arc, connecting the two points $\partial a(\mathbb{I}) \cap T$, together with a trivialization ν of its normal bundle in M which is compatible at the end points, with the trivialization induced from the orientation of T . Abusing the notation, we denote $\mathbb{I}(D^2 \times D^1)$ by \mathbb{I} . Associated with a framed arc \mathbb{I} , let $T(\mathbb{I}) \subset M$ be the properly embedded 1-manifold obtained by doing band surgery on T along \mathbb{I} i.e.

$$T(\mathbb{I}) = (T - \mathbb{I} \cap T) \cup \mathbb{I}((\{x = -1\} \cup \{x = 1\}) \times [-1, 1]).$$

Note that if \mathbb{I} is orientation preserving, then the orientation on T induces an orientation on $T(\mathbb{I})$. Moreover, for every set $\mathbb{I} = \{\mathbb{I}_1, \dots, \mathbb{I}_n\}$ of framed arcs in (M, T) , denote the properly embedded 1-manifold constructed by doing surgery on T along the framed arcs $\mathbb{I}_1, \dots, \mathbb{I}_n$ by $T(\mathbb{I})$. Thus, if \mathbb{I} is a single framed arc, $T(\mathbb{I})$ and $T(\{\mathbb{I}\})$ are the same object.

Definition 4.1. A set $\mathbb{I} = \{\mathbb{I}_1, \dots, \mathbb{I}_n\}$ of framed arcs in (M, T) is called *acceptable* if for any i , \mathbb{I}_i is orientation preserving and $(M, T(\mathbb{I}))$ is a tangle.

Let $\mathbb{I} = \{\mathbb{I}_1, \dots, \mathbb{I}_n\}$ be an acceptable set of framed arcs in (M, T) . Corresponding to \mathbb{I} , we construct a cobordism $\mathcal{W}(\mathbb{I}) = (W(\mathbb{I}), F(\mathbb{I}))$ from (M, T) to $(M, T(\mathbb{I}))$ by attaching a *standard pair* to $(M \times [0, 1], T \times [0, 1])$ along $\mathbb{I} \subset M \times \{1\}$ as follows. The *standard saddle* is the pair (H, B) , which is identified in \mathbb{R}^4 via

$$H := D^2 \times D^1 \times D^1 = \left\{ (x, y, z, t) \in \mathbb{R}^4 \mid \begin{array}{l} x^2 + y^2 \leq 1 \\ z, t \in [-1, 1] \end{array} \right\} \text{ and}$$

$$B = \left\{ (x, y, z, t) \in D^2 \times D^1 \times D^1 \mid \begin{array}{l} (t+1)y^2 + (t-1)z^2 = 2t \\ x = 0 \end{array} \right\}$$

For $i \in \{-1, 1\}$, denote $\partial_i(H, B) := (D^2 \times D^1 \times \{i\}, B \cap (D^2 \times D^1 \times \{i\}))$. See Figure 1 for a picture of the projection of the standard pair over the 3-dimensional box $\{x = 0\} \times D^1 \times D^1$.

Let $\mathcal{W}(\mathbb{I}) = (W(\mathbb{I}), F(\mathbb{I}))$ denote the cobordism

$$\frac{(M \times [0, 1], T \times [0, 1]) \amalg (\amalg_{i=1}^n (H_i, B_i))}{\left\{ (\mathbb{I}_i \times \{1\}, (T \cap \mathbb{I}_i) \times \{1\}) \sim \partial_{-1}(H_i, B_i) \mid \text{for any } 1 \leq i \leq n \right\}}$$

after smoothing the corresponding corners. Here (H_i, B_i) are copies of the standard pair (H, B) for $i = 1, \dots, n$. Note that $W(\mathbb{I}) \simeq M \times [0, 1]$.

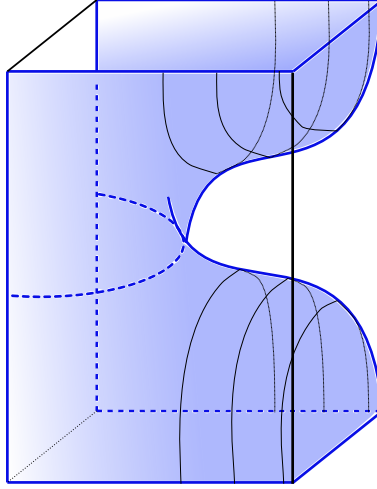

FIGURE 1. The standard pair, which is pictured in the cube $\{x = 0\} = [-1, 1]^3$.

Definition 4.2. A stable cobordism $\mathcal{W} = (W, F)$ from the tangle (M, T) to the tangle (M', T') is called *elementary*, if for a framed sphere \mathbb{S} or an acceptable set of framed arcs \mathbb{I} in (M, T) , \mathcal{W} is diffeomorphic to the corresponding cobordism $\mathcal{W}(\mathbb{S})$ or $\mathcal{W}(\mathbb{I})$.

Moreover, a *parametrized elementary cobordism* is an elementary cobordism \mathcal{W} as above, accompanied with one of the following:

- (1) A framed sphere $\mathbb{S} \subset M$, together with the isotopy class of a diffeomorphism

$$d : (M(\mathbb{S}), T) \rightarrow (M', T')$$

so that for a diffeomorphism $D : \mathcal{W}(\mathbb{S}) \rightarrow \mathcal{W}$ with $D|_{(M, T)} = \text{Id}$, we have $d = D|_{(M(\mathbb{S}), T)}$.

- (2) A framed arc $\mathbb{I} \subset M$, together with the isotopy class of a diffeomorphism

$$d : (M, T(\mathbb{I})) \rightarrow (M', T')$$

so that for a diffeomorphism $D : \mathcal{W}(\mathbb{I}) \rightarrow \mathcal{W}$ with $D|_{(M, T)} = \text{Id}$, we have $d = D|_{(M, T(\mathbb{I}))}$.

Note that in the above definition we might also have $\mathbb{S} = \emptyset$.

Definition 4.3. A *parametrized Cerf decomposition* of a stable cobordism $\mathcal{W} = (W, F)$ from a tangle (M, T) to a tangle (M', T') is a decomposition

$$\mathcal{W} = \mathcal{W}_1 \cup_{(M_1, T_1)} \cdots \cup_{(M_{m-1}, T_{m-1})} \mathcal{W}_m,$$

where $\mathcal{W}_i = (W_i, F_i)$ is a parametrized elementary cobordism from the tangle (M_{i-1}, T_{i-1}) to the tangle (M_i, T_i) , $(M_0, T_0) = (M, T)$ and $(M_m, T_m) = (M', T')$. For every $i = 1, \dots, m$, depending on the type of \mathcal{W}_i , we let (\mathbb{S}_i, d_i) or (\mathbb{I}_i, d_i) denote its parametrization.

4.2. Parametrized Morse data. Let $\mathcal{W} = (W, F)$ be a cobordism from (M, T) to (M', T') . A function $G : W \rightarrow [a, b]$ is called a Morse function on \mathcal{W} , if G has no critical points in a neighborhood of $\partial W \cup F$, both G and $g = G|_F$ are Morse (on W and F , respectively) and

$$G^{-1}(a) = M, \quad G^{-1}(b) = M' \quad \text{and} \quad G|_{\partial_h W} = \pi_2,$$

where π_2 is the projection over the second factor under an identification

$$(\partial_h W, \partial_h F) = (\partial M, \partial T) \times [a, b].$$

The set of critical points of G on \mathcal{W} , $\text{Crit}_{\mathcal{W}}(G)$, is defined as

$$\text{Crit}_{\mathcal{W}}(G) := \text{Crit}_W(G) \cup \text{Crit}(g)$$

where $\text{Crit}_W(G)$ and $\text{Crit}(g)$ are the sets of critical points of G on W and $g = G|_F$ on F , respectively. A Morse function G on \mathcal{W} is called *proper* if it has distinct values at its critical points on \mathcal{W} . G is called *indefinite* if both G and g , as Morse functions on W and F respectively, are

indefinite i.e. have no critical points with the minimal and maximal index. Therefore, if G is indefinite on \mathcal{W} , g has only critical points of index 1, while the critical points of G are of indices 1, 2 or 3.

Definition 4.4. Let $G : W \rightarrow [a, b]$ be a Morse function on the cobordism $\mathcal{W} = (W, F)$. A vector field ξ on W is called an *embedded gradient-like* vector field for G if it satisfies the following conditions:

- (1) For every $p \in W$ which is not in $\text{Crit}_{\mathcal{W}}(G)$, $dG_p(\xi_p) > 0$.
- (2) The vector field ξ is tangent to both F and $\partial_h W$.
- (3) For any critical point $p \in \text{Crit}_W(G)$ there is an open neighborhood $U \subset W$ of p together with a positively oriented local coordinate system (x_1, x_2, x_3, x_4) centered at p such that

$$G(x_1, x_2, x_3, x_4) = G(p) \pm x_1^2 \pm x_2^2 \pm x_3^2 \pm x_4^2 \quad \text{and} \quad \xi(x_1, x_2, x_3, x_4) = (\pm x_1, \pm x_2, \pm x_3, \pm x_4)$$

- (4) There is an open neighborhood $U \subset W$ of every critical point p of g and a positively oriented local coordinate system (x_1, x_2, y_1, y_2) centered at p , such that

$$U \cap F = \{(x_1, x_2, y_1, y_2) \in U \mid y_1 = y_2 = 0\},$$

$$G(x_1, x_2, y_1, y_2) = G(p) \pm x_1^2 \pm x_2^2 + y_1 \quad \text{and} \quad \xi = (\pm x_1, \pm x_2, y_1^2 + y_2^2, 0).$$

Definition 4.5. A *Morse datum* for \mathcal{W} is a triple $\mathfrak{M} = (G, \underline{b}, \xi)$, where

$$\underline{b} = (a = b_0 < \dots < b_m = b) \in \mathbb{R}^{m+1},$$

is an ordered $(m+1)$ -tuple of regular values for the proper Morse function $G : W \rightarrow [a, b]$ on \mathcal{W} , and ξ is an embedded gradient like vector field for G . Over each interval (b_i, b_{i+1}) , G has at most one critical point in W , and if it has a critical point in $G^{-1}(b_i, b_{i+1})$ then g has no critical point over this interval.

The Morse datum (G, \underline{b}, ξ) is called *good* if g is indefinite and $g^{-1}(b_i)$ is a union of arcs connecting $\partial_h^- W$ to $\partial_h^+ W$ for $i = 0, \dots, m$.

Any good Morse datum $\mathfrak{M} = (G, \underline{b}, \xi)$ induces a parametrized Cerf decomposition $\mathfrak{C}(G, \underline{b}, \xi)$ of \mathcal{W} by taking $W_i = G^{-1}[b_{i-1}, b_i]$, $F_i = g^{-1}[b_{i-1}, b_i]$ and $(M_i, T_i) = (G^{-1}(b_i), g^{-1}(b_i))$. If G has a critical point $p \in G^{-1}[b_{i-1}, b_i]$ of index k_i , the descending flow of ξ maps p to a $k_i - 1$ dimensional embedded sphere $S_i \subset G^{-1}(b_{i-1})$, which is disjoint from T_{i-1} . Moreover, using a positive local coordinate system in the neighborhood of p such that G and ξ have the standard structure, we obtain a framing for S_i . As in Remark 2.12 of [Juh], if $k_i = 0, 4$, the framed sphere \mathbb{S}_i does not depend on the choice of the local coordinates and is uniquely determined up to isotopy. Otherwise, for $k \neq 0, 4$, depending on the positive local coordinate system, we obtain two non-isotopic embedded framed sphere \mathbb{S}_i and $\overline{\mathbb{S}}_i$. Note that for any framed sphere $\mathbb{S} : S^{k-1} \times D^{4-k} \rightarrow M - T$ in a tangle (M, T) , $\overline{\mathbb{S}}$ is defined by

$$\overline{\mathbb{S}}(x, y) = \mathbb{S}(r_k(x), r_{4-k}(y)),$$

for $x \in S^{k-1} \subset \mathbb{R}^k$, $y \in D^{4-k} \subset \mathbb{R}^{4-k}$, where

$$r_k(x_1, x_2, \dots, x_k) = (-x_1, x_2, \dots, x_k).$$

Along with the framed sphere \mathbb{S}_i , we obtain a diffeomorphism

$$d_i : (M_{i-1}(\mathbb{S}_i), T_{i-1}) \longrightarrow (M_i, T_i)$$

which is given using the flow of the vector field ξ over $M_{i-1} \setminus \text{nd}(\mathbb{S}_i)$, the complement of the framed sphere \mathbb{S}_i . On the other hand, if g has index one critical points $p_1, \dots, p_{n_i} \in G^{-1}[b_{i-1}, b_i] \cap F$, the descending manifolds of p_1, \dots, p_{n_i} under the flow of ξ determines a set of orientation preserving framed arcs $\mathbb{I}_i = \{\mathbb{I}_1^i, \dots, \mathbb{I}_{n_i}^i\}$ with end points on $T_{i-1} = g^{-1}(b_{i-1})$. Since $g^{-1}(b_i)$ is a union of arcs connecting $\partial^- M_i$ to $\partial^+ M_i$, the set \mathbb{I}_i is acceptable. The flow of ξ gives a diffeomorphism

$$d_i : (M_{i-1}, T_{i-1}(\mathbb{I}_i)) \longrightarrow (M_i, T_i).$$

Furthermore, if G has no critical points in \mathcal{W}_i , we set $\mathbb{S}_i = \emptyset$ and the flow of ξ defines a diffeomorphism d_i from (M_{i-1}, T_{i-1}) to (M_i, T_i) .

Therefore, any good Morse datum $\mathfrak{M} = (G, \underline{b}, \xi)$ defines a parametrized Cerf decomposition for \mathcal{W} denoted by $\mathfrak{C}(\mathfrak{M})$, well-defined up to replacing some of the framed spheres \mathbb{S} by the corresponding framed spheres $\overline{\mathbb{S}}$. Because of this ambiguity, we say two good Morse data \mathfrak{M} and \mathfrak{M}' induce the same parametrized Cerf decompositions for \mathcal{W} if and only if the corresponding attaching spheres and attaching arcs coincide, while they are isotopic as framed spheres or framed arcs after replacing some framed spheres \mathbb{S} in $\mathfrak{C}(\mathfrak{M})$ with $\overline{\mathbb{S}}$.

Lemma 4.1. *Let \mathcal{W} be a stable cobordism. Then every parametrized Cerf decomposition for \mathcal{W} is induced by a good Morse datum.*

Proof. Suppose that \mathcal{W} is an elementary cobordism from (M, T) to (M', T') .

Case 1. \mathcal{W} is parametrized by a framed sphere \mathbb{S} in (M, T) and a diffeomorphism $d : (M(\mathbb{S}), T) \rightarrow (M', T')$. It follows from the proof of [Juh, Lemma 2.14], that one can define a Morse function $G' : \mathcal{W}(\mathbb{S}) \rightarrow [0, 1]$ together with an embedded gradient-like vector field ξ' on $\mathcal{W}(\mathbb{S}) = (W(\mathbb{S}), F(\mathbb{S}))$ such that G' has a single critical point, while $g' = G'|_{F(\mathbb{S})}$ has no critical points. Furthermore, the diffeomorphism induced by ξ' on $(M(\mathbb{S}), T)$ is $\text{Id}_{M(\mathbb{S})}$. For instance, if $\mathbb{S} = \emptyset$, then for the cobordism $\mathcal{W}(\mathbb{S}) = (M, T) \times [0, 1]$ we let $G' = \pi_2$ and $\xi' = \partial_t$. Then, $G = G' \circ D^{-1}$ and $\xi = D_* \xi'$ is the corresponding good Morse datum, where $D : \mathcal{W}(\mathbb{S}) \rightarrow \mathcal{W}$ is a diffeomorphism such that $D|_{(M, T)} = \text{Id}$ and $D|_{(M(\mathbb{S}), T)} = d$.

Case 2. \mathcal{W} is parametrized by an acceptable set of framed arcs $\mathbb{I} = \{\mathbb{I}_1, \dots, \mathbb{I}_n\}$, and a diffeomorphism $d : (M, T(\mathbb{I})) \rightarrow (M', T')$. For any i consider a small neighborhood N_i of \mathbb{I}_i in (M, T) . Let

$$(W_i, F_i) := \frac{(N_i, N_i \cap T) \times [0, 1] \amalg (H_i, B_i)}{(\mathbb{I}_i \times \{1\}, (T \cap \mathbb{I}_i) \times \{1\}) \sim \partial_{-1}(H_i, B_i)} \subset \mathcal{W}(\mathbb{I}).$$

Here (H_i, B_i) denotes a copy of the standard saddle (H, B) for $i = 1, \dots, n$. Let N be a small neighborhood of $D^2 \times D^1$ in \mathbb{R}^3 and \tilde{B} denote the corresponding saddle in $N \times D^1$. After smoothing the corners obtained from attaching the saddles, (W_i, F_i) is diffeomorphic with $(N \times D^1, \tilde{B})$. Choose a diffeomorphism

$$\phi_i : (W_i, F_i) \longrightarrow (N \times D^1, \tilde{B})$$

such that

$$\begin{aligned} \phi_i(\partial_1(H_i, B_i)) &= (D^2 \times D^1 \times \{1\}, \tilde{B} \cap (D^2 \times D^1 \times \{1\})) \quad \text{and} \\ \phi_i(N_i \times \{0\}, (N_i \cap T) \times \{0\}) &= (N \times \{-1\}, (\tilde{B} \cap N) \times \{-1\}). \end{aligned}$$

Moreover, for a sufficiently small $\nu \in \mathbb{R}^+$ and every $t \in (0, 1)$, if $(x, y, z) \in N$ belongs to the ν -neighborhood of ∂N , then

$$\phi^{-1}(x, y, z, 2t - 1) \in N_i \times \{t\}.$$

We define G'_i by

$$G'_i(y) := \begin{cases} \pi_2(y) & \text{if } y \in M \times [0, 1] - \amalg_{i=1}^n W_i \\ \frac{\pi_2(\phi_i(y)) + 1}{2} & \text{if } y \in W_i \end{cases}$$

This is a smooth function, by construction. We define the embedded gradient-like vector field ξ' on $\mathcal{W}(\mathbb{I})$ by pulling back the vector field $2\partial_t$ on $N \times D^1$ using ϕ_i and extending it to the rest of $M \times [0, 1]$ using ∂_t . It is now straightforward to check that the Morse function G' together with the embedded gradient-like vector field ξ' induces the identity diffeomorphism on $(M, T(\mathbb{I}))$. Hence, considering a diffeomorphism $D : \mathcal{W}(\mathbb{I}) \rightarrow \mathcal{W}$ for which $D|_{(M, T)} = \text{Id}$ and $D|_{(M, T(\mathbb{I}))} = d$, the Morse function $G = G' \circ D^{-1}$ and the gradient-like vector field $\xi = D_* \xi'$ is the corresponding Morse datum.

If \mathcal{W} is not an elementary cobordism, consider a parametrized Cerf decomposition

$$\mathcal{W} = \mathcal{W}_1 \cup_{(M_1, T_1)} \cdots \cup_{(M_{m-1}, T_{m-1})} \mathcal{W}_m$$

for \mathcal{W} . For each \mathcal{W}_i denote the corresponding Morse datum constructed as above by (G_i, ξ_i) . Fix an $(m+1)$ -tuple $\underline{b} = (a = b_0 < b_1 < \cdots < b_m = b)$ of real numbers, and let $a_i : [0, 1] \rightarrow [b_{i-1}, b_i]$ be the diffeomorphism $a_i(t) = (1-t)b_{i-1} + tb_i$. Then, we can modify the Morse functions $a_i \circ G_i$ and the gradient-like vector fields ξ_i , on a collar neighborhood of (M_i, T_i) such that they fit together to give a Morse function G and an embedded gradient-like vector field ξ on \mathcal{W} . \square

Lemma 4.2. *Suppose $\mathfrak{M} = (G, \underline{b}, \xi)$ and $\mathfrak{M}' = (G', \underline{b}', \xi')$ are two good Morse data for a stable cobordism $\mathcal{W} = (W, F)$ that induce the same parametrized Cerf decompositions. There exist diffeomorphisms $D : \mathcal{W} \rightarrow \mathcal{W}$ and $\phi : \mathbb{R} \rightarrow \mathbb{R}$ satisfying the followings:*

- (1) $\underline{b}' = \phi(\underline{b})$
- (2) $G' = \phi \circ G \circ D^{-1}$
- (3) for some $h \in C^\infty(W, \mathbb{R}^+)$ we have $D_*\xi = h.\xi'$
- (4) $D|_M = \text{Id}_M$ and $D|_{M'} = \text{Id}_{M'}$.

Proof. See proof of [Juh, Lemma 2.14]. \square

Proposition 4.3. *For every stable cobordism \mathcal{W} there exists a good Morse datum $\mathfrak{M} = (G, \underline{b}, \xi)$, and therefore a parametrized Cerf decomposition.*

Proof. Let $\mathcal{W} = (W, F)$ be a stable cobordism from (M, T) to (M', T') and let $g : F \rightarrow [0, 1]$ be a Morse function satisfying

$$g|_T \equiv 0, \quad g|_{T'} \equiv 1, \quad \text{and} \quad g|_{F \cap \partial_h W} = \pi_2.$$

Since every connected component of F has non-empty intersection with either of T and T' , we may assume that g has no minimal or maximal index critical point i.e. all critical points of g have index 1. Further, we assume that it has the same value over all of its critical points. We extend g to a tubular neighborhood of F such that it has no critical points and then extend it to a Morse function $G : W \rightarrow [0, 1]$. By a small perturbation in a neighborhood of the critical points of G , we may assume that G has distinct critical values and these values are distinct from the critical value of g . Finally, by a small perturbation in a neighborhood of the critical points of g we can transform G into a proper Morse function on \mathcal{W} , such that for every $p, q \in \text{Crit}(g)$ with $G(p) < G(q)$, G has no critical point on W above the interval $(G(p), G(q))$. It is straightforward to show that there is an embedded gradient-like vector field for every Morse function on \mathcal{W} . Let ξ be such a gradient-like vector field for G . Choose the ordered set

$$\underline{b} = \{0 = b_0 < b_1 < \cdots < b_m = 1\} \subset [0, 1]$$

of regular values for G such that for every $i = 1, \dots, m$, $\text{Crit}_W(G)$ has at most one element in $G^{-1}[b_{i-1}, b_i]$. Furthermore, for exactly one $1 \leq j \leq m$ all critical values of g lie in (b_{j-1}, b_j) , while $\text{Crit}_W(G)$ does not intersect $G^{-1}[b_{j-1}, b_j]$. The triple (G, \underline{b}, ξ) is a good Morse datum for \mathcal{W} and it thus gives a parametrized Cerf decomposition of \mathcal{W} . \square

4.3. Cerf moves. In this section, we describe *Cerf moves* on Morse data and discuss how corresponding parametrized Cerf decompositions change under these moves. For this purpose, fix a cobordism $\mathcal{W} = (W, F)$ from (M, T) to (M', T') . Let $\mathfrak{M} = (G, \underline{b}, \xi)$ and $\mathfrak{M}' = (G', \underline{b}', \xi')$ be parametrized Morse data for \mathcal{W} so that $G, G' : W \rightarrow [a, b]$ are proper Morse functions on \mathcal{W} .

Critical point cancellation/creation. The Morse data \mathfrak{M} and \mathfrak{M}' are related by a *critical point cancellation* if

(1) G and G' are related by a critical point cancellation i.e. there exist a family of smooth functions $\{G_t : W \rightarrow [a, b] | t \in [-1, 1]\}$ such that $G_{-1} = G$, $G_1 = G'$ and:

- For $t \in [-1, 1] - \{0\}$, G_t is a proper Morse function on W and G_0 has a *death* singularity at some point $p_o \in W$,
- The family is an elementary death ('chemin élémentaire de mort' in the sense of Cerf [Cer70, Section 2.3, p.71]) with support in a neighborhood U of p_o . More precisely, G_t does not depend on t outside U and for $t \in (0, 1]$ it has no critical points in U . Furthermore, there exist local coordinates (x_1, \dots, x_4) around p_o , such that for $t \in [-1, 1]$

$$G_t(x_1, \dots, x_4) = G_0(p_o) + x_1^3 + tx_1 - x_2^2 \cdots - x_k^2 + x_{k+1}^2 + \cdots + x_4^2$$

(2) Assume $\underline{b} = (a = b_0 < b_1 < \cdots < b_m = b)$. There is some $1 \leq j \leq m - 1$ such that $b_j = G_0(p_o)$, $\underline{b}' = \underline{b} - \{b_j\}$ while

$$b_{j-1} < G_0(p_o) - 2/3\sqrt{3} \quad \text{and} \quad b_{j+1} > G_0(p_o) + 2/3\sqrt{3}.$$

(3) Let p and q be the critical points of G where $b_{j-1} < G(p) < b_j < G(q) < b_{j+1}$ and canceled against each other at $t = 0$. The stable and unstable submanifolds $W^s(q)$ and $W^u(p)$ are transverse and intersect in a single flow line. Moreover, the neighborhood U is in fact a neighborhood of

$$(W^u(p) \cup W^s(q)) \cap G^{-1}[b_{j-1}, b_{j+1}],$$

and ξ' coincide with ξ outside U .

A *critical point creation* is the reverse of a critical point cancellation.

Suppose that the good Morse data \mathfrak{M}' is obtained from \mathfrak{M} by a critical point cancellation as above. The induced parametrized Cerf decomposition $\mathfrak{C}(\mathfrak{M}') : \mathcal{W}'_1 \cup \cdots \cup \mathcal{W}'_{m-1}$ is related to $\mathfrak{C}(\mathfrak{M}) : \mathcal{W}_1 \cup \cdots \cup \mathcal{W}_m$ as follows. For any $i < j - 1$ the parametrized elementary cobordisms \mathcal{W}'_i coincides with \mathcal{W}_i , while for $i \geq j$ it coincides with \mathcal{W}_{i+1} . Further, let $b(\mathbb{S}_j)$ in $(M_{j-1}(\mathbb{S}_j), T_{j-1})$ denote the belt sphere of the attached handle to \mathbb{S}_j . The framed sphere $\tilde{\mathbb{S}}_{j+1} := d_j^{-1}(\mathbb{S}_{j+1})$ intersects $b(\mathbb{S}_j)$ in a single point, thus there is a diffeomorphism

$$\phi : (M_{j-1}, T_{j-1}) \rightarrow (M_{j-1}(\mathbb{S}_j)(\tilde{\mathbb{S}}_{j+1}), T_{j-1})$$

which is unique up to isotopy and fixes $(M_{j-1}, T_{j-1}) \cap (M_{j-1}(\mathbb{S}_j)(\tilde{\mathbb{S}}_{j+1}), T_{j-1})$ (See [Cer70], [Juh, Definition 2.17] and [Mil65, Theorem 5.4]). Then, \mathcal{W}'_j is a cobordism from $(M'_{j-1}, T'_{j-1}) = (M_{j-1}, T_{j-1})$ to $(M'_j, T'_j) = (M_{j+1}, T_{j+1})$ parametrized by the framed sphere $\mathbb{S}'_j = \emptyset$ and the diffeomorphism d'_j , which is isotopic to $d_{j+1} \circ \tilde{d}_j \circ \phi$. Here,

$$\tilde{d}_j : (M_{j-1}(\mathbb{S}_j)(\tilde{\mathbb{S}}_{j+1}), T_{j-1}) \longrightarrow (M_j(\mathbb{S}_{j+1}), T_j)$$

is the diffeomorphism induced by d_j . For more details, see [Juh, Lemma 2.15].

Critical point switches. The Morse data \mathfrak{M} and \mathfrak{M}' are related by *critical point switch* if $\xi = \xi'$, $\underline{b} \setminus b_j = \underline{b}' \setminus b'_j$ for some j , and G is connected to G' by a smooth family $\{G_t : W \rightarrow [a, b] | t \in [-1, 1]\}$ of Morse functions which are proper for all but finitely many values of t in $[-1, 1]$ and $\text{Crit}_W(G_t)$ is independent of t . Furthermore, depending on the type of critical point switch, the family $\{G_t\}$ satisfies one of the followings:

Type I. For critical points $p, q \in \text{Crit}_W(G)$ we have

$$b_{j-1} < G(p) < b_j < G(q) < b_{j+1} \quad \text{and} \quad b_{j-1} < G'(q) < b'_j < G'(p) < b_{j+1}.$$

Then $G_0(p) = G_0(q)$ while $tG_t(p) > tG_t(q)$ for $t \neq 0$. Further, the family $\{G_t\}_{t \in [-1, 1]}$ is an elementary upward or downward switch ('chemin élémentaire de croisement, ascendant or descendant' in the sense of Cerf [Cer70, Chapter II, p.40]) in a neighborhood U of

$$W_p^s(q) := W^s(q) \cap G^{-1}([G(p), G(q)]) \quad \text{or} \quad W_q^u(p) := W^u(p) \cap G^{-1}([G(p), G(q)]).$$

In particular, G_t is independent of t outside U while $G_t - G$ is constant in an open neighborhood containing the critical points inside U .

Type II. For critical points $p \in \text{Crit}_W(G)$ and $q_1, \dots, q_n \in \text{Crit}(g)$ we have

$$b_{j-1} < G(p) < b_j < G(q_1) < \dots < G(q_n) < b_{j+1}$$

while $b_{j-1} < G'(q_1) < \dots < G'(q_n) < b_j < G'(p) < b_{j+1}$. Then $G_t(q_1) < \dots < G_t(q_n) < G_t(p)$ for some $\delta > 0$ and every $1 - \delta < t \leq 1$. Furthermore, the family $\{G_t\}_{t \in [-1, 1]}$ is an elementary switch ('chemin élémentaire de croisement' in the sense of Cerf [Cer70, Chapter II, p.40]) with support in a neighborhood U of

$$W_q^u(p) := W^u(p) \cap G^{-1}([G(p), G(q_n)])$$

and $G_t|_{W-U}$ is independent of t .

Type III. There are critical points $p, q \in \text{Crit}(g)$ so that $b_{j-1} < g(p) < g(q) < b_j$, g has no critical value in $(g(p), g(q))$ and $b_{j-1} < g'(q) < g'(p) < b_j$. In this case $G_0(p) = G_0(q)$, while $tG_t(p) > tG_t(q)$ for $t \neq 0$. Moreover, for a neighborhood U of

$$W^s(q) \cap G^{-1}([G(p), G(q)]) \quad \text{or} \quad W^u(p) \cap G^{-1}([G(p), G(q)]),$$

G_t is independent of t in $W - U$. Furthermore, in a neighborhood $V \subset U$ of p and q , $G_t - G$ is constant.

If the good Morse data \mathfrak{M} and \mathfrak{M}' are related by a critical point switch of type III, then it is straightforward to see that $\mathfrak{C}(\mathfrak{M})$ and $\mathfrak{C}(\mathfrak{M}')$ are the same. However, if they are related by a critical point switch of type I or II, then $\mathfrak{C}(\mathfrak{M})$ and $\mathfrak{C}(\mathfrak{M}')$ are related as in Lemma 2.16 of [Juh]. Let us recall the statement of the aforementioned Lemma (with a small modification) for a critical point switch of type II.

Lemma 4.4. (*Critical point switch of type II*) *With the above notation fixed, if $\mathfrak{M} = (G, \underline{b}, \xi)$ and $\mathfrak{M}' = (G', \underline{b}', \xi')$ are related by a critical point switch of type II, then the parametrized elementary cobordism \mathcal{W}_i coincides with \mathcal{W}'_i for any $i < j - 1$ and $i > j$. Moreover,*

- $\mathbb{I}_{j+1} \cap d_j(b(\mathbb{S}_j)) = \emptyset$ where $b(\mathbb{S}_j)$ denotes the belt sphere of the attached handle to \mathbb{S}_j ,
- $d_j(\mathbb{I}'_j) = \mathbb{I}_{j+1}$ and $d'_j(\mathbb{S}_j) = \mathbb{S}'_{j+1}$,
- *The diagram*

$$\begin{array}{ccc} (M_{j-1}(\mathbb{S}_j), T_{j-1}(\mathbb{I}'_j)) & \xrightarrow{(d_j)^{\mathbb{I}'_j}} & (M_j, T_j(\mathbb{I}_{j+1})) \\ \downarrow (d'_j)^{\mathbb{S}_j} & & \downarrow d_{j+1} \\ (M'_j(\mathbb{S}'_{j+1}), T'_j) & \xrightarrow{d'_{j+1}} & (M_{j+1}, T_{j+1}). \end{array}$$

is commutative. Here, $(d_j)^{\mathbb{I}'_j}$ and $(d'_j)^{\mathbb{S}_j}$ are induced by d_j and d'_j , respectively.

Proof. See proof of Lemma 2.16 in [Juh]. □

Isotopy on embedded gradient-like vector field. We say that the Morse data $\mathfrak{M} = (G, \underline{b}, \xi)$ and $\mathfrak{M}' = (G', \underline{b}', \xi')$ are related by doing *isotopy on the embedded gradient-like vector field*, if $G = G'$ and $\underline{b} = \underline{b}'$.

If the good Morse data \mathfrak{M} and \mathfrak{M}' are related by doing isotopy on the embedded-gradient like vector fields, their corresponding parametrized Cerf decompositions, possibly after reversing some of the framed spheres, are related by ambient isotopies [Juh, Remark 2.11]. More precisely, for any j there is an ambient isotopy $\{\phi_t\}_{t \in [0, 1]}$ of (M_{j-1}, T_{j-1}) with $\phi_0 = \text{Id}_{M_{j-1}}$, so that if \mathcal{W}_j is parametrized by (\mathbb{S}_j, d_j) (or (\mathbb{I}_j, d_j)) then $\phi_1(\mathbb{S}_j) = \mathbb{S}'_j$ and $d'_j = d_j \circ (\phi_1)^{-1}$ ($\phi_1(\mathbb{I}_j) = \mathbb{I}'_j$ and $d'_j = d_j \circ (\phi_1)^{-1}$). Here, ϕ_1 is the diffeomorphism induced by ϕ_1 .

Adding/removing regular values. The Morse data $\mathfrak{M} = (G, \underline{b}, \xi)$ and $\mathfrak{M}' = (G', \underline{b}', \xi')$ are related by *adding or removing regular values*, if $G = G'$ and $\xi = \xi'$. Thus, $\mathfrak{M}(\underline{b} \cup \underline{b}') = (G, \underline{b} \cup \underline{b}', \xi)$ is a Morse datum for \mathcal{W} obtained from \mathfrak{M} and \mathfrak{M}' by adding regular values. If both \mathfrak{M} and \mathfrak{M}' are good, the induced parametrized Cerf decomposition $\mathfrak{C}(\mathfrak{M}(\underline{b} \cup \underline{b}'))$ is obtained from $\mathfrak{C}(\mathfrak{M})$ and

$\mathfrak{C}(\mathfrak{M}')$ by *splitting* product cobordisms and cobordisms parametrized by acceptable sets of framed arcs.

Definition 4.6. We say that a parametrized Cerf decomposition \mathfrak{C}' is obtained from \mathfrak{C} by a *splitting*, if there is some j such that for any $i < j$ the parametrized elementary cobordism \mathcal{W}'_i coincides with \mathcal{W}_i while for any $i > j + 1$ it coincides with \mathcal{W}_{i-1} . Furthermore, the cobordism \mathcal{W}_j splits as $\mathcal{W}'_j \cup_{(M'_j, T'_j)} \mathcal{W}'_{j+1}$ in \mathfrak{C}' , such that one of \mathcal{W}'_j or \mathcal{W}'_{j+1} , say \mathcal{W}'_j , is either parametrized by $(\mathbb{S}'_j = \emptyset, d'_j)$ or (\mathbb{I}'_j, d'_j) . If \mathcal{W}'_j is a product then, depending on the types of \mathcal{W}'_{j+1} and \mathcal{W}_j , we have either

$$\begin{aligned} \mathbb{S}_j &= d'^{-1}_j(\mathbb{S}'_{j+1}) \quad \text{and} \quad d_j = d'_{j+1} \circ (d'_j)^{\mathbb{S}_j}, \quad \text{or} \\ \mathbb{I}_j &= d'^{-1}_j(\mathbb{I}'_{j+1}) \quad \text{and} \quad d_j = d'_{j+1} \circ (d'_j)^{\mathbb{I}_j}. \end{aligned}$$

If \mathcal{W}'_j is parametrized by (\mathbb{I}'_j, d'_j) then \mathcal{W}'_{j+1} is parametrized by $(\mathbb{I}'_{j+1}, d'_{j+1})$. Moreover,

$$\mathbb{I}_j = \mathbb{I}'_j \amalg d'^{-1}_j(\mathbb{I}'_{j+1}) \quad \text{and} \quad d_j = d'_{j+1} \circ (d'_j)^{\mathbb{I}_j - \mathbb{I}'_j}.$$

The reverse of this move, is called *merging*.

Therefore, for any two good Morse data $\mathfrak{M} = (G, \underline{b}, \xi)$ and $\mathfrak{M} = (G, \underline{b}', \xi)$ we may change $\mathfrak{C}(\mathfrak{M})$ to $\mathfrak{C}(\mathfrak{M}')$ by first splitting and then merging.

Left-right equivalence. Let $\mathcal{W} = (W, F)$ be a cobordism from (M, T) to (M', T') . We say that the Morse functions G and G' on \mathcal{W} are related by a *left-right equivalence* if there are diffeomorphisms $\Phi : W \rightarrow W$ and $\phi : \mathbb{R} \rightarrow \mathbb{R}$ such that $\Phi|_{(M, T)} = \text{Id}_{(M, T)}$, $\Phi|_{(M', T')} = \text{Id}_{(M', T')}$, and $G' = \phi \circ G \circ \Phi^{-1}$. Moreover, we say that the good Morse data $\mathfrak{M} = (G, \underline{b}, \xi)$ and $\mathfrak{M}' = (G', \underline{b}', \xi')$ are related by a *left-right equivalence*, if G and G' are related by a left-right equivalence and under the corresponding diffeomorphisms $\underline{b}' = \phi \circ \underline{b}$ and $\xi' = \Phi_*(\xi)$. In this case, the parametrized Cerf decomposition $\mathfrak{C}(\mathfrak{M}')$ is obtained from $\mathfrak{C}(\mathfrak{M})$ by a *diffeomorphism equivalence*. This means that $\mathcal{W}'_i = \Phi(\mathcal{W}_i)$ as parametrized elementary cobordisms i.e. depending on the type of \mathcal{W}_i , $\mathbb{S}'_i = \Phi(\mathbb{S}_i)$ or $\mathbb{I}'_i = \Phi(\mathbb{I}_i)$ and $d'_i = \Phi_i \circ d_i \circ (\Phi'_{i-1})^{-1}$, where $\Phi_i = \Phi|_{(M_i, T_i)}$ and Φ'_i is the map induced by Φ_i on $(M_i(\mathbb{S}_{i+1}), T_i)$ or on $(M_i, T_i(\mathbb{I}_{i+1}))$.

4.4. Parametrized Cerf decomposition theorem. The goal of this subsection is to show that any two good Morse data associated with a stable cobordism can be related by a sequence of Cerf moves. As before, let $\mathfrak{M} = (G, \underline{b}, \xi)$ and $\mathfrak{M}' = (G', \underline{b}', \xi')$ be good Morse data for \mathcal{W} so that $G, G' : W \rightarrow [a, b]$ are proper.

Lemma 4.5. *If there exists a smooth family $\{G_t\}_{t \in [0, 1]}$ of proper Morse functions on \mathcal{W} with $G_0 = G$ and $G_1 = G'$ then G is related to G' by a left-right equivalence.*

Proof. The proof is similar to the proof of Lemma 3.1 in [GWW13] with minor modifications. For every $t \in [0, 1]$, G_t is proper. Therefore, we have a smooth family $\{\phi_t : \mathbb{R} \rightarrow \mathbb{R}\}_{t \in [0, 1]}$ of diffeomorphisms of \mathbb{R} such that $\phi_0 = \text{Id}$ and for every $t \in [0, 1]$, $\phi_t^{-1} \circ G_t$ has the same critical values as G . Moreover, if for $p \in \text{Crit}_{\mathcal{W}}(G)$ and $p_t \in \text{Crit}_{\mathcal{W}}(G_t)$ we have $\phi_t^{-1} G_t(p_t) = G(p)$ then either both p and p_t are critical points in W or both are critical points in F .

Let $G'_t = \phi_t^{-1} \circ G_t$. Consider a point $(x_0, t_0) \in W \times [0, 1]$ such that $x_0 \in \text{Crit}_W(G'_{t_0})$. For sufficiently small values of $\epsilon > 0$ and $\delta > 0$, we can find the local coordinates $\theta_t : B_\epsilon \subset \mathbb{R}^4 \rightarrow W$ for every $t \in (t_0 - \delta, t_0 + \delta)$ such that $G'_t \circ \theta_t$ takes the normal form

$$G'_t \circ \theta_t(x_1, \dots, x_4) = G'_{t_0}(x_0) + \sum \pm x_i^2.$$

Similarly, if $x_0 \in \text{Crit}(g_t)$, for sufficiently small $\epsilon, \delta > 0$, we can find local coordinates $\theta_t : B_\epsilon \subset \mathbb{R}^4 \rightarrow W$ for $t \in (t_0 - \delta, t_0 + \delta)$, so that F is given by $\{x_3 = x_4 = 0\}$ in these coordinates and

$$G'_t \circ \theta_t(x_1, \dots, x_4) = G'_{t_0}(x_0) \pm x_1^2 \pm x_2^2 + x_3.$$

Then, for any (x, t) in a neighborhood of (x_0, t_0) defined as above, let

$$v(x, t) := \left(\frac{d}{ds} \theta_{t+s}(\theta_t^{-1}(x)) \Big|_{s=0}, 1 \right).$$

It is straightforward to show that $\{G'_t\}_{t \in [0,1]}$ is constant along the flow lines of $v(x, t)$ in this neighborhood. Consider a finite set of pairs $\{(U_i, v_i) \mid i = 1, \dots, n\}$, where each pair consists of an open neighborhoods $U_i \subset W \times [0, 1]$ as above and the corresponding vector field v_i , such that

$$\{(x, t) \in W \times [0, 1] \mid x \in \text{Crit}_W(G'_t)\} \subset \bigcup_{i=1}^n U_i.$$

Consider an open set $U_0 \subset W \times I$ in the complement of the critical points such that $\bigcup_{i=0}^n U_i$ covers $W \times [0, 1]$. We define vector field v_0 on U_0 as

$$v_0(x, t) := -(\partial_t G'_t)(dG'_t(\xi_t))^{-1} \xi_t, 1).$$

Here, $\{\xi_t\}_{t \in [0,1]}$ is a smooth family of vector fields on W such that for every $t \in [0, 1]$, ξ_t is an embedded gradient-like vector field for G'_t . Note that $\{G'_t\}_{t \in [0,1]}$ remain constant along the flow lines of v_0 . Thus, we may patch the above local vector fields and construct a global vector field v on $W \times [0, 1]$ such that $\{G'_t\}_{t \in [0,1]}$ remain constant along its flow lines. Hence, $G'_1 \circ \Phi_1 = G$, where Φ_1 is the time-one map of the flow of v . Therefore, $\phi_1^{-1} \circ G' \circ \Phi_1 = G$. \square

Definition 4.7. Given a stable cobordism $\mathcal{W} = (W, F)$, a proper Morse function G on \mathcal{W} is called *almost ordered* if

- (1) G is ordered as a Morse function on W , i.e. for any $p, q \in \text{Crit}_W(G)$, $\text{ind}(p) < \text{ind}(q)$ implies $G(p) < G(q)$.
- (2) For every $p \in \text{Crit}_W(G)$ with $\text{ind}(p) < 2$, $G(p)$ is smaller than the critical values of g , while for $p \in \text{Crit}_W(G)$ with $\text{ind}(p) > 2$, $G(p)$ is greater than the critical values of g .

The Morse function G on \mathcal{W} is called *ordered* if G is almost ordered and for every $p \in \text{Crit}_W(G)$ with $\text{ind}(p) = 2$, $G(p)$ is greater than the critical values of g . A good Morse datum $\mathfrak{M} = (G, \underline{b}, \xi)$ for \mathcal{W} is called *almost ordered* if G is almost ordered and it is called *ordered* if G is ordered.

Lemma 4.6. *Any good Morse datum $\mathfrak{M} = (G, \underline{b}, \xi)$ for $\mathcal{W} = (W, F)$ can be connected by a sequence of Cerf moves to an ordered good Morse datum $\mathfrak{M}' = (G', \underline{b}', \xi')$ such that under these moves, the Morse function remains constant in an open neighborhood of F .*

Proof. Consider a consecutive pair of critical points $p, q \in \text{Crit}_W(G)$ with wrong order, say $\text{ind}(p) > \text{ind}(q)$ while $G(p) < G(q)$. After removing the extra regular values we may assume $(G(p), G(q))$ contains exactly one $b_j \in \underline{b}$. Depending on the type of the critical points p and q one of the followings hold:

Case 1. $p, q \in \text{Crit}_W(G)$ and $\text{ind}(p) > \text{ind}(q)$. By a dimension count one can show that for a generic embedded gradient-like vector field ξ ,

$$W^u(p) \cap W^s(q) \cap G^{-1}(b_j) = \emptyset.$$

Since ξ is gradient-like, for some $\delta > 0$, the submanifolds $W^u(p)$ and $W^s(q)$ are disjoint from F in $G^{-1}((G(p) - \delta, G(q) + \delta))$. Therefore, we have an elementary switch supported in a neighborhood of

$$W^u(p) \cap G^{-1}((G(p) - \delta, G(q) + \delta)) \quad \text{or} \quad W^s(q) \cap G^{-1}((G(p) - \delta, G(q) + \delta)),$$

and disjoint from F , that connects G to a proper Morse function G' satisfying $G'(q) < G'(p)$. Furthermore, in a small neighborhood U of F we have $G|_U = G'|_U$. Let $\xi' = \xi$ and pick \underline{b}' such that $\underline{b}' - b'_j = \underline{b} - b_j$ and $G'(q) < b'_j < G'(p)$. Then the resulted good Morse datum $\mathfrak{M}' = (G', \underline{b}', \xi')$ satisfies the required conditions.

Case 2. $p \in \text{Crit}(g)$ and $q \in \text{Crit}_W(G)$, with $\text{ind}(q) \leq 1$. Let

$$\{p_1, \dots, p_{n_j} = p\} \subset \text{Crit}(g)$$

be the set of critical points of g such that

$$b_{j-1} < g(p_1) < \cdots < g(p_{n_j}) < b_j.$$

Similar to Case 1, after changing ξ to a generic embedded gradient-like vector field and by a dimension count, one can assume that

$$\left(\bigcup_{i=1}^{n_j} W^u(p_i) \right) \cap W^s(q) \cap G^{-1}(b_j) = \emptyset.$$

Moreover, for some $\delta > 0$, $W^s(q)$ is disjoint from F in $G^{-1}((G(p_1) - \delta, G(q)))$. Thus, as before, there is an elementary critical point switch, supported in a neighborhood of

$$W^s(q) \cap G^{-1}(G(p_1) - \delta, G(q)),$$

and disjoint from F , which changes the order of q and $\{p_1, \dots, p_{n_j}\}$. The rest of the argument is as in Case 1 with no modifications.

Case 3. $q \in \text{Crit}(g)$ and $p \in \text{Crit}_W(G)$, with $\text{ind}(p) \geq 2$. This is the same as Case 2.

By induction on the number of pairs of critical points with wrong order, we are done. \square

Proposition 4.7. *Let $\mathfrak{M} = (G, \underline{b}, \xi)$ and $\mathfrak{M}' = (G', \underline{b}', \xi')$ be ordered, indefinite and good Morse data for a stable cobordism $\mathcal{W} = (W, F)$. Assume that on a tubular neighborhood U of F we have $G|_U = G'|_U$ and $\xi|_U = \xi'|_U$. Then \mathfrak{M} can be connected to \mathfrak{M}' by a sequence of Cerf moves such that it stays indefinite and almost ordered throughout. Further, the Cerf moves can be chosen so that the Morse function and the gradient-like vector field are not changed on U .*

Proof. Suppose \mathcal{W} is a cobordism from (M, T) to (M', T') . Let $a = G|_M = G'|_M$ and $b = G|_{M'} = G'|_{M'}$. First, we show that G can be connected to G' by a smooth, *generic* family $\{G_t\}_{t \in [0,1]}$, in the sense of [GK15, Definition 2.3], such that for all but finitely many values of t in $[0, 1]$, G_t is a proper, indefinite and almost ordered Morse function. Moreover, for every $t \in [0, 1]$ we have $G_t|_U = G|_U = G'|_U$. The argument is similar to the proof of Theorem 4.5 in [GK15].

The Morse functions G and G' coincide on U , so there is a generic family $\{G_t\}_{t \in [0,1]}$ connecting G to G' such that $G_t|_U = G|_U = G'|_U$. Associated with $\{G_t\}$ consider a generic family of embedded gradient-like vector fields $\{\xi_t\}_{t \in [0,1]}$ connecting ξ to ξ' such that $\xi_t|_U$ does not depend on t . The family $\{G_t\}$ is called *indefinite* if for all but finitely many values of t , G_t is an indefinite Morse function. If $\{G_t\}$ is not indefinite, consider $r \in [a, b]$ such that an index zero critical point is born at time r in $p_r \in W$. Corresponding to this critical point, we have a path of critical points

$$P = \{(t, p_t) \in [r, s] \times W \mid p_t \in \text{Crit}_W(G_t) \text{ and } \text{ind}(p_t) = 0 \text{ for } t \in (r, s)\}$$

in $[0, 1] \times W$ such that at p_s the index zero critical point is canceled against an index one critical point. Since W is connected, for every $t \in (r, s)$ there is an index one critical point q_t of G_t which cancels p_t , i.e. $W^s(q_t) \cap W^u(p_t)$ is a single flow line. Therefore, for some $\delta > 0$, and an ordered sequence

$$(r = t_0 < t_1 < \cdots < t_n = s),$$

we have paths of index one critical points

$$Q^i = \{(t, q_t^i) \in I_i \times W \mid q_t^i \in \text{Crit}_W(G_t)\}, \quad i = 1, \dots, n,$$

such that q_t^i cancels p_t for $t \in I_i$, where

$$I_1 = [r, t_1 + \delta), I_2 = (t_1 - \delta, t_2 + \delta), \dots, I_n = (t_{n-1} - \delta, s].$$

Moreover, $q_r^1 = p_r$ and $q_s^n = p_s$. Since $\{\xi_t\}$ is generic, for any $1 \leq i \leq n$ and $t \in I_i$, the submanifold

$$(4) \quad W_P^s(q_t^i) = W^s(q_t^i) \cap G_t^{-1}([G_t(p_t), G_t(q_t^i)])$$

is disjoint from F . Thus we can use the *Unmerge Lemma* [GK15, Lemma 4.6] to cancel P against Q^i on the non-overlapping parts of the intervals I_i for $i = 2, \dots, n-1$. Then we use either *Eye*

Death Lemma [GK15, Lemma 4.7] or *Swallowtail Death Lemma* [GK15, Lemma 4.8] to cancel over overlaps and on the intervals I_1 and I_n .

Next, we make the family $\{G_t\}$ almost ordered. It is straightforward that one can use generic homotopies which pass through *cuspidal* crossings to move all critical point creations before all critical point switches and all critical point cancellations after all critical point switches. See [GK15, Section 2] for the exact definition of a cusp-fold crossing homotopy, see Figure 2.

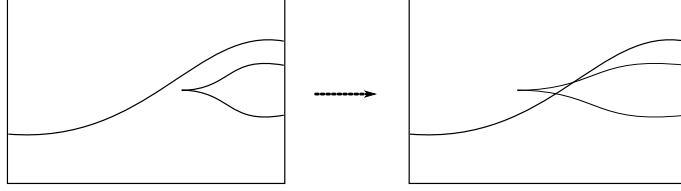

FIGURE 2. In a cusp-fold homotopy, the Cerf graphic, which is given by $\{(t, G_t(p)) \in [0, 1] \times [a, b] \mid p \in \text{Crit}(G_t)\}$, changes as above.

Then, we modify $\{G_t\}$ such that if an index one/two (two/three) critical point creation/cancellation happens at a point $p_t \in W$ and time t , then $G_t(p_t)$ is larger than the values of index one (two) critical points of G_t and smaller than the values of index two (three) critical points of G_t . Since G and G' are ordered, such modifications of $\{G_t\}$ can be achieved through generic homotopies supported in a neighborhood of an arc disjoint from F .

Suppose that for paths of critical points

$$P = \{(t, p_t) \in I_{pq} \times W \mid p_t \in \text{Crit}_W(G_t)\} \quad \text{and} \quad Q = \{(t, q_t) \in I_{pq} \times W \mid q_t \in \text{Crit}_W(G_t)\}$$

with $\text{ind}(P) < \text{ind}(Q)$ we have $G_t(p_t) > G_t(q_t)$ for any $t \in I_{pq}$. Further, suppose that G_t has no critical value in $(G_t(p_t), G_t(q_t))$. It follows from the definition of a gradient-like vector field that $W^s(p_t)$ and $W^u(q_t)$ are disjoint from F in $G_t^{-1}([G_t(q_t), G_t(p_t)])$. Moreover, since ξ_t is generic, by counting dimensions we conclude that $W^s(p_t)$ does not intersect $W^u(q_t)$. Therefore, there is a homotopy supported in a neighborhood of the 1-parameter family of descending disks $\{W_Q^s(p_t)\}$ or the 1-parameter family of ascending disks $\{W_P^u(q_t)\}$ that pulls P below Q . Note that $W_Q^s(p_t)$ and $W_P^u(q_t)$ are defined as in Equation 4.

The other possibility is that, for a path of index 1 critical points

$$P = \{(t, p_t) \in I_p \times W \mid p_t \in \text{Crit}_W(G)\},$$

$g(q) < G_t(p_t)$ for some $q \in \text{Crit}(g)$ and G_t has no critical value in $(g(q), G_t(p_t))$. As before, we can modify $\{G_t\}$ by a homotopy disjoint from F and supported in a neighborhood of $\{W_q^s(p_t)\}$ to pull P below q . Similarly, we can modify $\{G_t\}$ through homotopies such that for every index three critical point p_t of G_t (with $t \in [0, 1]$) and every $q \in \text{Crit}(g)$, we have $G_t(p_t) > g(q)$.

As a result, we obtain a generic, smooth path $\{G_t\}_{t \in [0, 1]}$ of Morse functions which are proper, indefinite and almost ordered for all but finitely many values of t . Let m and m' denote the smallest and largest critical values of g . The next step is to modify $\{G_t\}$ through generic homotopies such that there exists an ordered set

$$(0 = t_0 < t_1 < \cdots < t_k = 1) \subset [0, 1]$$

for which G_{t_i} is proper, indefinite and almost ordered with no critical points in W above the interval $[m, m']$. Moreover, for any $1 \leq i \leq k$ the family $\{G_t\}_{t \in [t_{i-1}, t_i]}$ satisfies one of the followings:

- (1) For every $t \in [t_{i-1}, t_i]$, G_t is a proper Morse function on W .
- (2) $\{G_t\}_{t \in [t_{i-1}, t_i]}$ corresponds to a critical point creation/cancellation connecting $G_{t_{i-1}}$ and G_{t_i} .
- (3) $\{G_t\}_{t \in [t_{i-1}, t_i]}$ corresponds to switching two critical points of $G_{t_{i-1}}$ on W with equal index, thus to a critical point switch of type I.

- (4) $\{G_t\}_{t \in [t_{i-1}, t_i]}$ corresponds to switching some $p \in \text{Crit}_W(G_{t_{i-1}})$ with all of the critical points of g , thus a critical point switch of type II.

In order to do so, we apply generic homotopies similar to Reidemeister II and Reidemeister III fold-crossings in [GK15, p.11, p.12] [See Figures 3 and 4]. The only difference is that we also have paths consisting of the critical points of g . Assume that for some $c \in [0, 1]$, there are index 2 critical points p and p' of G_c , such that $G_c(p) = G_c(p') = d$ and $d < m'$. There is a critical point $q \in \text{Crit}(g)$ so that G_c has no critical value in the interval $(d, g(q))$. For sufficiently small $\delta > 0$, consider paths of index 2 critical points

$$P = \{(t, p_t) \in (c - \delta, c + \delta) \times W \mid p_t \in \text{Crit}_W(G_t)\} \quad \text{and}$$

$$P' = \{(t, p'_t) \in (c - \delta, c + \delta) \times W \mid p'_t \in \text{Crit}_W(G_t)\}$$

so that $p = p_c$ and $p' = p'_c$. Since $\{\xi_t\}$ is generic, we may arrange for descending disks $W^s(p)$ and $W^s(p')$ to be disjoint from q . Thus, we may modify $\{G_t\}_{t \in (c - \delta, c + \delta)}$ through generic homotopies, disjoint from F , to make $G_t(p_t), G_t(p'_t) > g(q)$ for any $t \in (c - \delta, c + \delta)$. We continue these modifications, until for any two critical point $p, p' \in \text{Crit}_W(G_t)$ with $d = G_t(p) = G_t(p')$ either $d < m$ or $d > m'$.

With a similar argument, we may use generic homotopies through Reidemeister II fold-crossings, that are disjoint from F , and make $\{G_t\}_{t \in [0, 1]}$ to satisfy the required conditions. Note that the family $\{G_t\}_{t \in [0, 1]}$ remains indefinite and almost ordered under these homotopies.

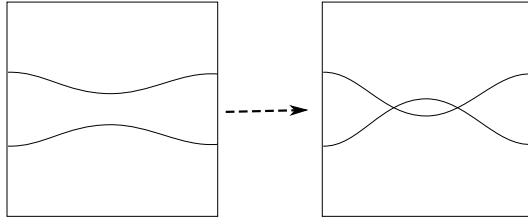

FIGURE 3. Reidemeister II fold-crossing.

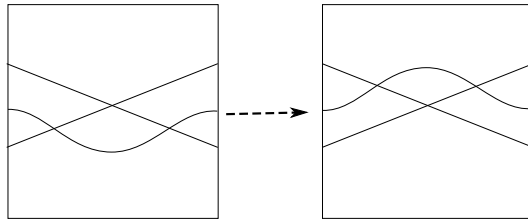

FIGURE 4. Reidemeister III fold-crossing.

For any $1 \leq i \leq k$, if $\{G_t\}_{t \in [t_{i-1}, t_i]}$ is of type (2) or (3), we may choose the interval $[t_{i-1}, t_i]$ sufficiently small so that we can obtain an elementary critical point creation/cancellation or critical point switch by a perturbation of $\{G_t\}_{t \in [t_{i-1}, t_i]}$.

Let us assume that an embedded gradient-like vector field ξ_i , together with an ordered set of regular values \underline{b}_i for G_{t_i} is given, such that $\mathfrak{M}_i = (G_{t_i}, \xi_i, \underline{b}_i)$ is a good Morse datum for \mathcal{W} for some $i \in \{0, 1, \dots, k-1\}$. Moreover, assume that $\underline{b}_i \cap [m, M] = \emptyset$. Then, depending on the type of the family $\{G_t\}_{t \in [t_i, t_{i+1}]}$ we may construct a good Morse datum $\mathfrak{M}_{i+1} = (G_{t_{i+1}}, \xi_{i+1}, \underline{b}_{i+1})$. In fact, if the family $\{G_t\}_{t \in [t_i, t_{i+1}]}$ satisfies (1), (2), (3) or (4), then \mathfrak{M}_{i+1} is obtained from \mathfrak{M}_i by a left-right equivalence, a critical point creation/cancellation, a critical point switch of type I or a critical point switch of type II, respectively.

Inductively, we get a sequence of good Morse data $\mathfrak{M}_i = (G_i, \xi_i, \underline{b}_i)$ for $i = 1, 2, \dots, k$ with $G_k = G'$, which is obtained by applying a sequence of Cerf moves to $\mathfrak{M} = \mathfrak{M}_0$. Then, \mathfrak{M}_k is related

to \mathfrak{M}' by isotopies of the gradient-like vector field and adding or removing regular values, and we are done. \square

Lemma 4.8. *Let $\mathcal{W} = (W, F)$ be a stable cobordism and suppose that $g, g' : F \rightarrow [a, b]$ are indefinite Morse functions over F . Then g can be connected to g' by a generic family $\{g_t\}_{t \in [0,1]}$ of indefinite Morse functions.*

Proof. This is a corollary of Theorem 4.5 in [GK15]. \square

Proposition 4.9. *Let $\mathfrak{M} = (G, \underline{b}, \xi)$ be an indefinite, ordered and good Morse datum for the stable cobordism $\mathcal{W} = (W, F)$. Fix a proper, indefinite and ordered Morse function $G'' : W \rightarrow [a'', b'']$ on \mathcal{W} . Then \mathfrak{M} can be connected by a sequence of Cerf moves to a Morse datum $\mathfrak{M}' = (G', \underline{b}', \xi')$, such that the Morse datum stays ordered throughout and G' coincides with G'' in a neighborhood of F .*

Proof. After removing some regular values, we may assume that for some integer n , all critical values of g lie in the interval (b_n, b_{n+1}) . Choose the regular values m and m' for G'' such that for any $p \in \text{Crit}_W(G'')$

$$\begin{cases} G''(p) < m & \text{if } \text{ind}(p) = 1 \\ G''(p) > m' & \text{if } \text{ind}(p) = 2 \end{cases}.$$

Moreover, we require that every critical point $p \in F$ of $g'' = G''|_F$ satisfies $m < G''(p) < m'$. Let $a = \min(\underline{b})$ and $b = \max(\underline{b})$. Consider a diffeomorphism $\phi : [a, b] \rightarrow [a'', b'']$ with

$$\phi(a) = a'', \quad \phi(b) = b'', \quad \phi(b_n) = m \quad \text{and} \quad \phi(b_{n+1}) = m'.$$

We apply the left-right equivalence move defined by ϕ and Id_W on the Morse datum (G, \underline{b}, ξ) to get $(\phi \circ G, \phi(\underline{b}), \xi)$. Lemma 4.8 implies that $\phi \circ g$ can be connected to g'' by a generic family $\{g_t\}_{t \in [0,1]}$ of indefinite Morse functions on F which fails to be proper at the times

$$0 < c_1 < c_2 < \cdots < c_l < 1.$$

Moreover, we may assume that for every $t \in [0, 1]$ the critical values of g_t lie in interval (m, m') . For any $1 \leq i \leq l$, consider a sufficiently small $\delta_i > 0$ such that

$$0 < t_1 < c_1 < t_2 < t_3 < c_2 < \cdots < t_{2l-1} < c_l < t_{2l} < 1$$

where $t_{2i-1} = c_i - \delta_i$ and $t_{2i} = c_i + \delta_i$. Let p^i and q^i denote the critical points of g_{c_i} for which

$$g_{c_i}(p^i) = g_{c_i}(q^i), \quad g_{2i-1}(p^i) < g_{2i-1}(q^i) \quad \text{and} \quad g_{2i}(p^i) > g_{2i}(q^i).$$

Here $g_i = g_{t_i}$. Since δ_i is sufficiently small, we may perturb $\{g_t\}_{t \in [t_{2i-1}, t_{2i}]}$ and change it to an elementary switch. In particular, there is a vector field $\tilde{\xi}_i$ on F which is gradient-like for any g_t and the homotopy $\{g_t\}_{t \in [t_{2i-1}, t_{2i}]}$ is supported in a neighborhood V_i of

$$W^s(p^i) \cap g_{2i-1}^{-1}[g_{2i-1}(p^i), g_{2i}(p^i)] \quad \text{or} \quad W^u(q^i) \cap g_{2i-1}^{-1}[g_{2i}(q^i), g_{2i-1}(q^i)].$$

Without loss of generality, assume V_i is a neighborhood of

$$W^s(p^i) \cap g_{2i-1}^{-1}[g_{2i-1}(p^i), g_{2i}(p^i)].$$

For a bump function ω_i supported in V_i we have

$$g_t = g_{2i-1} + (t - t_{2i-1})\omega_i \quad \text{for} \quad t \in [t_{2i-1}, t_{2i}].$$

Furthermore, ω_i is constant in a neighborhood of p^i .

Let G_{2i-1} be an extension of g_{2i-1} to an ordered Morse function on \mathcal{W} . Consider an embedded gradient-like vector field ξ_i for G_{2i-1} such that $\xi_i|_F = \tilde{\xi}_i$. We may extend ω_i to a bump function on W , denoted by Ω_i and supported in an open neighborhood \bar{V}_i of

$$W^s(p^i) \cap G_{2i-1}^{-1}[G_{2i-1}(p^i), G_{2i}(p^i)],$$

and is constant on a neighborhood of p^i in W . Moreover, for every $t \in [t_{2i-1}, t_{2i}]$

$$G_t = G_{2i-1} + (t - t_{2i-1})\Omega_i$$

is a Morse function on \mathcal{W} with $\text{Crit}_{\mathcal{W}}(G_t) = \text{Crit}_{\mathcal{W}}(G_{2i-1})$ and corresponds to the embedded-gradient like vector field ξ_i . Thus, $\{G_t\}_{t \in [t_{2i-1}, t_{2i}]}$ is an elementary critical point switch. Further, $\mathfrak{M}_{2i} = (G_{2i}, \phi \circ \underline{b}, \xi_i)$ is an ordered, good Morse datum, obtained from $\mathfrak{M}_{2i-1} = (G_{2i-1}, \phi \circ \underline{b}, \xi_i)$ by a critical point switch of type III.

On the other hand, we may find a family

$$\{\psi_t \mid t \in [t_{2i}, t_{2i+1}]\} \quad \text{for } i = 1, \dots, l-1,$$

of diffeomorphisms of \mathbb{R} such that $\psi_{t_{2i}} = \text{Id}$ and $\psi_t \circ g_t$ have the same critical values as g_{2i} . With the same argument as in the proof of Lemma 4.5, we may define a vector field $v(x, t)$ on $F \times [t_{2i}, t_{2i+1}]$ such that the corresponding diffeomorphism

$$\Psi_t : F \times \{t_{2i}\} \rightarrow F \times \{t\}$$

satisfies $\psi_t \circ g_t \circ \Psi_t|_{F \times \{t_{2i}\}} = g_{2i}$. After choosing an arbitrary connection on a tubular neighborhood $\text{nd}(F)$ of F in W we may extend v to a vector field over $\text{nd}(F) \times [t_{2i}, t_{2i+1}]$ and correspondingly, extend Ψ_t from $F \times \{t_{2i}\}$ to a diffeomorphism

$$\Psi_t : \text{nd}(F) \times \{t_{2i}\} \rightarrow \text{nd}(F) \times \{t\}.$$

Suppose that we have an extension of g_{2i} to an ordered Morse function G_{2i} on \mathcal{W} . Then for any $t \in [t_{2i}, t_{2i+1}]$ the Morse function $G_{2i} \circ \Psi_t^{-1}$ is defined on the tubular neighborhood $\text{nd}(F) \times \{t\} \subset W$ of $F \times \{t\}$ and has no critical points. Fix the vector field ∂_t on the complement of $F \times [t_{2i}, t_{2i+1}]$. By patching the vector fields v and ∂_t using a partition of unity, we get a global vector field, still denoted by $v(x, t)$, on $W \times [t_{2i}, t_{2i+1}]$. The flow of v defines a family of diffeomorphisms

$$\{\Psi_t : W \times \{t_{2i}\} \rightarrow W \times \{t\} \mid t \in [t_{2i}, t_{2i+1}]\}.$$

Furthermore, the family

$$\{G_t := G_{2i} \circ \Psi_t^{-1} : W \times \{t\} \rightarrow \mathbb{R} \mid t \in [t_{2i}, t_{2i+1}]\}$$

is a family of ordered Morse function on \mathcal{W} such that $G_t|_F = \phi_t \circ g_t$. Therefore, any ordered Morse function G_{2i} on \mathcal{W} with $G_{2i}|_F = g_{2i}$ can be connected by left-right equivalence to an ordered Morse function G_{2i+1} on \mathcal{W} such that $G_{2i+1}|_F = g_{2i+1}$ and $G_{2i+1}|_{W-\text{nd}(F)} = G_{2i}|_{W-\text{nd}(F)}$.

We may thus connect $\mathfrak{M} = (G, \xi, \underline{b})$ to a Morse datum $\widetilde{\mathfrak{M}} = (\widetilde{G}, \widetilde{\xi}, \underline{b})$ by a sequence of Cerf moves, such that

$$\widetilde{G}|_F = G''|_F \quad \text{and} \quad \widetilde{G}|_{W-U} = G|_{W-U}$$

for an open neighborhood U of F . Moreover, $\text{Crit}_W(\widetilde{G}) = \text{Crit}_W(G'')$ is a subset of $W \setminus U$ and the Morse datum remains good, indefinite and ordered throughout.

Finally, after a small perturbation in a neighborhood of F , we may arrange for $t\widetilde{G} + (1-t)G''$ to be a family of Morse functions with no critical points in a neighborhood $\widetilde{U} \subset U$ of F . Let $v'(x, t)$ be the corresponding vector field on $\widetilde{U} \times [0, 1]$ as in the proof of Lemma 4.5. Define a global vector field v' on $W \times [0, 1]$ by patching v' in \widetilde{U} with the vector field ∂_t on $(W - F) \times [0, 1]$ using a partition of unity. Denote the time-one flow of v' by Φ_1 . Then, the Morse datum $\mathfrak{M}' = (G', \underline{b}', \xi')$ is obtained from $\widetilde{\mathfrak{M}}$ by the left-right equivalence corresponding to $\text{Id}_{\mathbb{R}}$ and Φ_1^{-1} (so that in particular, we have $G' = \widetilde{G} \circ \Phi_1^{-1}$), and satisfies the required conditions. \square

Combining Propositions 4.7 and 4.9, we deduce that:

Corollary 4.10. *Let $\mathfrak{M} = (G, \underline{b}, \xi)$ and $\mathfrak{M}' = (G', \underline{b}', \xi')$ be ordered, good and indefinite Morse data for a stable cobordism $\mathcal{W} = (W, F)$. Then, \mathfrak{M} and \mathfrak{M}' can be connected by a sequence of Cerf moves. Moreover, we can keep the Morse data almost ordered, and avoid index zero and four critical points throughout the sequence.*

Lemma 4.6 and Corollary 4.10 implies the following theorem, which will be called the *parametrized Cerf decomposition theorem* in this paper.

Theorem 4.11. *Any two good and indefinite Morse data for an stable cobordism $\mathcal{W} = (W, F)$, may be connected by a sequence of Cerf moves. Moreover, we can avoid index zero and four critical points throughout the sequence.*

4.5. Ordered Morse data and parametrized decompositions. Let $\mathcal{W} = (W, F)$ be a stable cobordism from the tangle (M, T) to (M', T') . Suppose that $G : \mathcal{W} \rightarrow [a, b]$ is an indefinite, ordered Morse function. There is an ordered set of regular values $b = (b_0 = a < b_1 < b_2 < b_3 = b)$ so that for any $p \in \text{Crit}_{\mathcal{W}}(G)$, one of the following holds:

- if $p \in \text{Crit}_W(G)$ and $\text{ind}(p) = i$ then $b_{i-1} < G(p) < b_i$,
- if $p \in \text{Crit}(g)$ then $b_1 < g(p) < b_2$.

Any such set of regular values gives a decomposition

$$\mathcal{W} = \mathcal{W}_1 \cup_{(M_1, T_1)} \mathcal{W}_2 \cup_{(M_2, T_2)} \mathcal{W}_3$$

where $(M_i, T_i) = \mathcal{W} \cap G^{-1}(b_i)$ and $\mathcal{W}_i = \mathcal{W} \cap G^{-1}([b_{i-1}, b_i])$. Choose a gradient-like vector field ξ for G . It induces a parametrization on each $\mathcal{W}_i = (W_i, F_i)$. More precisely, for $i = 1, 3$, ξ specifies a set $\mathbb{S}_i \subset M_{i-1} \setminus T_{i-1}$ of pairwise disjoint, framed $(i-1)$ -spheres such that W_i is diffeomorphic to $W(\mathbb{S}_i)$, the cobordism obtained by attaching i -handles to M_{i-1} along \mathbb{S}_i . Moreover, it determines a diffeomorphism $d_i : (M_{i-1}(\mathbb{S}_i), T_{i-1}) \rightarrow (M_i, T_i)$. Similarly, ξ determines a framed link \mathbb{S}_2 and an acceptable set of framed arcs \mathbb{I} in (M_1, T_1) , along with a diffeomorphism $d_2 : (M_1(\mathbb{S}_2), T_1(\mathbb{I})) \rightarrow (M_2, T_2)$. Any parametrized decomposition of this form is called *indexed*. For any indexed parametrized decomposition of \mathcal{W} as above, there is an indefinite, ordered Morse function G , a gradient-like vector field ξ and a 4-tuple of regular values that specifies it. Any such triple (G, ξ, b) is called a *simplified Morse datum*.

Suppose that

$$\tilde{\mathcal{C}} : \mathcal{W} = \mathcal{W}_1 \cup_{(M_1, T_1)} \mathcal{W}_2 \cup_{(M_2, T_2)} \mathcal{W}_3 \quad \text{and} \quad \tilde{\mathcal{C}}' : \mathcal{W} = \mathcal{W}'_1 \cup_{(M'_1, T'_1)} \mathcal{W}'_2 \cup_{(M'_2, T'_2)} \mathcal{W}'_3$$

are indexed parametrized decompositions for \mathcal{W} . For $i = 1, 3$, let (\mathbb{S}_i, d_i) and (\mathbb{S}'_i, d'_i) denote the parametrization of \mathcal{W}_i and \mathcal{W}'_i , respectively. In addition, assume $(\mathbb{S}_2, \mathbb{I}, d_2)$ and $(\mathbb{S}'_2, \mathbb{I}', d'_2)$ are the parametrization of \mathcal{W}_2 and \mathcal{W}'_2 , respectively. Then, $\tilde{\mathcal{C}}'$ is obtained from $\tilde{\mathcal{C}}$ by creation of an index one/two critical point if:

- \mathcal{W}_3 coincides with \mathcal{W}'_3 as parametrized cobordisms.
- $\mathbb{S}'_1 = \mathbb{S}_1 \amalg s$, where $s \subset M \setminus (T \cup \mathbb{S}_1)$ is a framed 0-sphere,
- $\mathbb{S}'_2 = d'_1 \circ \tilde{d}_1^{-1}(\mathbb{S}_2) \amalg k$ where $k \subset M'_1 \setminus T'_1$ is a framed knot disjoint from $d'_1 \circ \tilde{d}_1^{-1}(\mathbb{S}_2)$. Here, $\tilde{d}_1 : M(\mathbb{S}'_1) \rightarrow M_1(s)$ is the diffeomorphism induced by d_1 . Moreover, $\mathbb{I}' = d'_1 \circ \tilde{d}_1^{-1}(\mathbb{I})$
- The framed knot $\tilde{k} = \tilde{d}_1 \circ (d'_1)^{-1}(k)$ intersects the belt sphere of s at one point. As a result, there is a corresponding diffeomorphism

$$\phi : (M_1, T_1) \rightarrow (M_1(s)(\tilde{k}), T_1).$$

Note that $\phi(\mathbb{S}_2) = \mathbb{S}_2$ and $\phi(\mathbb{I}) = \mathbb{I}$.

- $d_2 = d'_2 \circ D \circ \Phi$ where

$$\Phi : (M_1(\mathbb{S}_2), T_1(\mathbb{I})) \rightarrow (M_1(s)(\tilde{k})(\mathbb{S}_2), T_1(\mathbb{I})) \quad \text{and}$$

$$D : (M_1(s)(\tilde{k})(\mathbb{S}_2), T_1(\mathbb{I})) \rightarrow (M'_1(\mathbb{S}'_2), T(\mathbb{I}'))$$

are diffeomorphisms induced by ϕ and $d'_1 \circ (\tilde{d}_1)^{-1}$, respectively.

The inverse of this move describes cancellation of a pair of index one/two critical points. Similarly, one may describe creation and cancellation of a pair of index two/three critical points.

Theorem 4.12. *With the above notation fixed, any two indexed parametrized decompositions*

$$\tilde{\mathcal{C}} : \mathcal{W} = \mathcal{W}_1 \cup_{(M_1, T_1)} \mathcal{W}_2 \cup_{(M_2, T_2)} \mathcal{W}_3 \quad \text{and} \quad \tilde{\mathcal{C}}' : \mathcal{W} = \mathcal{W}'_1 \cup_{(M'_1, T'_1)} \mathcal{W}'_2 \cup_{(M'_2, T'_2)} \mathcal{W}'_3$$

can be connected by a sequence of the following moves:

- (1) Sliding one component of \mathbb{S}_i on another component of \mathbb{S}_i , for $i = 1, 2, 3$,
- (2) Sliding one component of \mathbb{I} on another component of $\mathbb{I} \amalg \mathbb{S}_2$,
- (3) Sliding one component of \mathbb{S}_2 on a component of \mathbb{I} ,
- (4) Creation and cancellation of index one/two or two/three critical points,
- (5) Diffeomorphism equivalences.

Proof. The proof is a straightforward application of Corollary 4.10. □

5. ONE-HANDLES, THREE-HANDLES AND THE COBORDISM MAPS

5.1. Adding one-handles. Fix an algebra \mathbb{A} over $\mathbb{F} = \mathbb{Z}/2\mathbb{Z}$ as before. Let $\mathcal{T} = [M, T, \mathfrak{s}, \mathbf{u}]$ be an \mathbb{A} -tangle and $\mathbb{S} \subset M \setminus T$ be a framed 0-sphere. Recall that $M' = M(\mathbb{S})$ denotes the 3-manifold obtained from M after attaching a 1-handle along \mathbb{S} . If components of \mathbb{S} lie in the same component of M , then M' is diffeomorphic to $M \# (S^1 \times S^2)$. Otherwise, M' has one component which is the connected sum of the corresponding components of M . Let $T' = T$ and $\mathbf{u}' = \mathbf{u}$. It is straightforward that (M', T') is a balanced tangle with \mathbb{A} -coloring \mathbf{u}' .

Associated with \mathbb{S} , we obtain a cobordim $W(\mathbb{S})$ from M to M' , by attaching a 1-handle along $\mathbb{S} \times \{1\}$ to $M \times [0, 1]$. Let $F = T \times [0, 1] \subset W(\mathbb{S})$ and regard \mathbf{u} also as a map $\mathbf{u}_F : \pi_0(F) = \pi_0(T) \rightarrow \mathbb{A}$. Then, $(W(\mathbb{S}), F)$ is a stable cobordism from (M, T) to (M', T') and \mathbf{u}_F induces the \mathbb{A} -colorings \mathbf{u} and \mathbf{u}' on (M, T) and (M', T') , respectively. Given any Spin^c class \mathfrak{t} on $W(\mathbb{S})$ such that $\mathfrak{s} = \mathfrak{t}|_M$, we get an \mathbb{A} -cobordism $\mathcal{C} = [W(\mathbb{S}), F, \mathfrak{t}, \mathbf{u}_F]$ from \mathcal{T} to $\mathcal{T}' = [M', T', \mathfrak{s}', \mathbf{u}']$ where $\mathfrak{s}' = \mathfrak{t}|_{M'}$. In fact, the Spin^c structure \mathfrak{s} always determines \mathfrak{t} and thus \mathfrak{s}' . Let $\mathcal{C}(\mathbb{S}) = \mathcal{C}$ and $\mathcal{T}(\mathbb{S}) = \mathcal{T}'$.

We may choose a Heegaard surface Σ for (M, T) so that it cuts each one of the two disjoint balls in a disk. Denote the boundary curves of these two disks by C_1 and C_2 , and their centers by w_1 and w_2 , respectively. Further, each connected component T_i of T cuts Σ in a single transverse point z_i , let $\mathbf{z} = \{z_1, \dots, z_\ell\}$. For appropriate collections $\boldsymbol{\alpha}$ and $\boldsymbol{\beta}$ of pairwise disjoint circles on $\Sigma \setminus \mathbf{z}$ that bound disks on the two sides of Σ in $M \setminus T$, we get a Heegaard diagram

$$\mathcal{H} = (\Sigma, \boldsymbol{\alpha}, \boldsymbol{\beta}, \mathbf{u} : \mathbf{z} = \{z_1, \dots, z_\ell\} \rightarrow \mathbb{A}, \mathfrak{s})$$

for \mathcal{T} . In this situation, a Heegaard diagram for \mathcal{T}' may be constructed as follows. There is a properly embedded cylinder S on the one-handle attached to M with boundary circles C_1 and C_2 . If we remove the two disks with centers w_1 and w_2 from Σ and glue S to the resulting surface (which has C_1 and C_2 as its two boundary components) we obtain a Heegaard surface Σ' for M' . Let α and β be circles on S which bound disks on the two sides of Σ' , and cut each other in a pair of canceling intersection points, i.e. are Hamiltonian isotopes of each other. Then,

$$(\Sigma', \boldsymbol{\alpha}' = \boldsymbol{\alpha} \cup \{\alpha\}, \boldsymbol{\beta}' = \boldsymbol{\beta} \cup \{\beta\}, \mathbf{z})$$

is a Heegaard diagram for (M', T') . Moreover, if \mathcal{H} is \mathfrak{s} -admissible in the strong sense of [AE15, Remark 4.6], the diagram

$$\mathcal{H}' = (\Sigma', \boldsymbol{\alpha}', \boldsymbol{\beta}', \mathbf{u} : \mathbf{z} \rightarrow \mathbb{A}, \mathfrak{s}')$$

is a Heegaard diagram for \mathcal{T}' . We will thus assume the above stronger form of admissibility for the Heegaard diagram \mathcal{H} .

The union of the cylinder S and the aforementioned disks with centers w_1 and w_2 is a sphere, which will be denoted by \bar{S} . We may label the two intersection points between α and β by $\theta_{\alpha\beta}$ and $\theta_{\beta\alpha}$, so that the bigons on the cylinder S connect $\theta_{\alpha\beta}$ to $\theta_{\beta\alpha}$ as the domains of the Whitney disks for the Heegaard diagram $H_S = (\bar{S}, \alpha, \beta, w_1, w_2)$.

With the above two Heegaard diagrams fixed, and given an \mathbb{A} -module \mathbb{M} , we construct a cobordism map from $\text{HF}^{\mathbb{M}}(\mathcal{T})$ to $\text{HF}^{\mathbb{M}}(\mathcal{T}')$ associated with adding the 1-handle along the framed 0-sphere \mathbb{S} . A completely similar construction would give a cobordism map associated with attaching a 3-handle along a framed 2-sphere.

5.2. Stretching the necks in Heegaard diagrams. The construction of the cobordism map for 1-handles rests on a slight generalization of [OS08, Theorem 5.1], which will be discussed in the present subsection.

Proposition 5.1. *Fix the Heegaard diagrams*

$$\mathcal{H}^i = (\Sigma^i, \boldsymbol{\alpha}^i, \boldsymbol{\beta}^i, \mathbf{z}^i), \quad i = 1, 2,$$

with extra marked points $\mathbf{w}^i = \{w_1^i, \dots, w_l^i\}$ on $\Sigma^i \setminus (\boldsymbol{\alpha}^i \cup \boldsymbol{\beta}^i \cup \mathbf{z}^i)$ for $i = 1, 2$. Let Σ denote the surface obtained from Σ^1 and Σ^2 by attaching l one-handles (necks) which connect w_1^1 to w_1^2 , for $j = 1, \dots, l$. Denote the number of curves in $\boldsymbol{\alpha}^i$ and $\boldsymbol{\beta}^i$ by d^i and the genus of Σ^i by g^i . For

$i = 1, 2$, choose a Whitney disk ϕ^i for \mathcal{H}^i , with $n_{w_j^1}(\phi^1) = n_{w_j^2}(\phi^2) = k_j$ and let $\phi = \phi^1 \star \phi^2$ be the homotopy class of the Whitney disk obtained by joining ϕ^1 and ϕ^2 along the necks.

(1) $\mu(\phi) = \mu(\phi^1) + \mu(\phi^2) - 2(k_1 + \cdots + k_l)$.

(2) Let J_t be a path of almost-complex structures on Σ , which are stretched along the necks, so that all necks have length t , and as $t \rightarrow \infty$ converges to a degenerate path of almost complex structures on

$$\Sigma^1 \vee \Sigma^2 = \frac{\Sigma_1 \amalg \Sigma_2}{\{w_i^1 \sim w_i^2 \mid i = 1, \dots, l\}}$$

giving the path J^i of almost complex structures on Σ^i . If for any $R \in \mathbb{R}$, there is some $t > R$ so that the moduli space $\mathcal{M}(\phi)$ is non-empty for J_t , then the moduli spaces of broken pseudo-holomorphic flowlines representing ϕ^1 and ϕ^2 are non-empty.

(3) Suppose \mathcal{H}^i and ϕ^i satisfy the followings:

(a) $\mu(\phi^1) = 1$, $\mu(\phi^2) = 2(k_1 + \cdots + k_l)$ and $\mathbf{u}(\phi^1) \neq 0$,

(b) All components of $\Sigma^2 \setminus \alpha^2$ and $\Sigma^2 \setminus \beta^2$ are punctured spheres and $d^2 > g^2$.

If J^1 and J^2 are generic, then for sufficiently large t , the moduli space $\mathcal{M}(\phi)$ may be identified with the fiber product

$$\mathcal{M}(\phi^1) \times_{\text{Sym}^{k_1}(\mathbb{D}) \times \cdots \times \text{Sym}^{k_l}(\mathbb{D})} \mathcal{M}(\phi^2) = \{(u^1, u^2) \mid u^i \in \mathcal{M}(\phi^i), \rho^1(u^1) = \rho^2(u^2)\}$$

where $\rho^i = \rho_1^i \times \cdots \times \rho_l^i$ denotes the product of evaluation maps

$$\rho_j^i = \rho_{w_j^i} : \mathcal{M}(\phi^i) \longrightarrow \text{Sym}^{k_j}(\mathbb{D}), \quad \rho_j^i(u) = u^{-1}(\{w_j^i\} \times \text{Sym}^{d_j-1}).$$

Proof. The proof of Proposition 5.1 is basically the same as the proof of [OS08, Theorem 5.1], and uses the cylindrical reformulation of Heegaard Floer homology by Lipshitz [Lip06]. We only need to make a small modification to the last part of the argument of Ozsváth and Szabó. In fact, the proof of the first two claims remains unchanged. We will thus focus on the proof of the last claim.

Consider a sequence $\{t_j\}$ of real numbers which converges to ∞ such that $\mathcal{M}(\phi)$ is nonempty for each J_{t_j} . In Lipshitz reformulation, as we stretch the necks (i.e. as $j \rightarrow \infty$), every sequence $\{v_j\}_{j \in \mathbb{Z}^+}$ of curves with $v_j \in \mathcal{M}_{J_{t_j}}(\phi)$ has a subsequence which converges to a pseudo holomorphic curve in the symplectic manifold

$$\begin{aligned} W(\infty) &= ((\Sigma^1 - \mathbf{w}^1) \times [0, 1] \times \mathbb{R}) \amalg ((\Sigma^2 - \mathbf{w}^2) \times [0, 1] \times \mathbb{R}) \\ &= (W^1 - \mathbf{w}^1 \times [0, 1] \times \mathbb{R}) \amalg (W^2 - \mathbf{w}^2 \times [0, 1] \times \mathbb{R}). \end{aligned}$$

which may be completed to a J^1 -holomorphic curve in the symplectic manifold $W^1 = \Sigma^1 \times [0, 1] \times \mathbb{R}$ and a J^2 -holomorphic curve in $W^2 = \Sigma^2 \times [0, 1] \times \mathbb{R}$. The components of this limit consist of pre-glued flowlines, boundary degenerations and nodal curves supported entirely inside the fibers of the projection map to $\mathbb{D} \simeq [0, 1] \times \mathbb{R}$, which are identified with $\Sigma^1 \vee \Sigma^2$. By ignoring the matching conditions for the pre-glued flowlines we obtain the representative in $\mathcal{M}(\phi^1)$ and $\mathcal{M}(\phi^2)$ (in fact, this proves the second claim).

Let us now assume that $\mu(\phi^1) = 1$. Since $\mathbf{u}(\phi^1) \neq 0$, in the above Gromov limit we obtain a J^1 -holomorphic representative u^1 of ϕ^1 and possibly a broken flow-line representative of ϕ^2 . If this latter representative has no closed components, a component u^2 of it forms a pre-glued flowline together with u^1 . Since other possible components of ϕ^2 (including the boundary degenerations) each correspond to a positive share of the Maslov index, it follows that $\mu(u^2) \leq 2(k_1 + \cdots + k_l)$, with equality happening only if u^2 represents ϕ^2 and there are no other components. For a generic point

$$\Delta = \rho^1(u^1) \in \text{Sym}^{k_1}(\mathbb{D}) \times \cdots \times \text{Sym}^{k_l}(\mathbb{D})$$

the moduli space $(\rho^2)^{-1}(\Delta)$, which contains u^2 , is of expected dimension $\mu(u^2) - 2(k_1 + \cdots + k_l)$. Thus, u^2 is forced to represent ϕ^2 if J^1 (and thus Δ) is generic.

The difference with the argument of Ozsváth and Szabó appears when we consider the possibility of having closed components in the broken flowline representing ϕ^2 . Let us assume that these closed components represent $m[\Sigma^2]$. After deleting these components we obtain a new class ψ^2 , represented by u^2 , with

$$\mu(\psi^2) = \mu(\phi^2) - 2m(d^2 - g^2 + 1).$$

Moreover, each component Δ'_j of

$$\rho^2(u^2) = \Delta' = (\Delta'_1, \dots, \Delta'_l) \in \text{Sym}^{k_1}(\mathbb{D}) \times \dots \times \text{Sym}^{k_l}(\mathbb{D})$$

is obtained from the component Δ_j of $\rho^1(u^1) = \Delta$ by deleting m points $\{p_1, \dots, p_m\}$ from it. Note that these m points are determined by the projection of the closed components in W^2 over \mathbb{D} , and are thus the same for $\Delta_1, \dots, \Delta_l$. This means that the components of Δ have the points p_1, \dots, p_m in common. The subset of $\mathcal{M}(\phi^1)$ consisting of J^1 -holomorphic curves satisfying this condition is of expected dimension

$$\mu(\phi^1) - 2m(l - 1) = 1 - 2m(l - 1).$$

If $m > 0$, $l > 1$, and J^1 is generic, this subset of $\mathcal{M}(\phi^1)$ is empty. The only remaining case is thus the case where $l = 1$ and $m > 0$.

In this latter case, the argument of Ozsváth and Szabó may be used. The moduli space of all $u^2 \in \mathcal{M}(\phi^2)$ with $\rho^2(u^2) = \Delta'$ is of expected dimension

$$\mu(\phi_2) - 2(k_1 - m) = 2k_1 - 2m(d_2 + 1 - g_2) - 2(k_1 - m) = -2m(d_2 - g_2) < 0$$

and hence is empty for a generic choice of J^1 and J^2 .

It follows that every weak limit of the curves in $\mathcal{M}(\phi)$, as we stretch the necks, is in correspondence with a pre-glued curve in

$$\{(u^1, u^2) \mid u^i \in \mathcal{M}(\phi^i), \rho^1(u^1) = \rho^2(u^2)\} = \mathcal{M}(\phi^1) \times_{\text{Sym}^{k_1}(\mathbb{D}) \times \dots \times \text{Sym}^{k_l}(\mathbb{D})} \mathcal{M}(\phi^2).$$

Moreover, from a pre-glued curve we may obtain an actual J_{t_j} -holomorphic curve if j is sufficiently large. This completes the proof. \square

5.3. Construction of the cobordism map. Choose a generic path J of almost complex structures on the Heegaard surface Σ . We identify (\bar{S}, w_1, w_2) with $(\mathbb{P}^1, 0, \infty)$ and denote the induced complex structure on \bar{S} by J_S . Let J' be a generic path of almost-complex structures on Σ' which is sufficiently close to the join of J and J_S .

Let $f_{\mathbb{S}} : \text{CF}_J(\mathcal{H}) \rightarrow \text{CF}_{J'}(\mathcal{H}')$ be the homomorphism defined as

$$f_{\mathbb{S}}(\mathbf{x}) := \mathbf{x} \times \{\theta_{\alpha\beta}\} \in \text{CF}_{J'}(\mathcal{H}')$$

for any generator $\mathbf{x} \in \mathbb{T}_{\alpha} \cap \mathbb{T}_{\beta}$ representing the Spin^c class \mathfrak{s} .

Proposition 5.2. *The homomorphism $f_{\mathbb{S}}$ is a chain map.*

Proof. Let $\mathbf{x} \in \mathbb{T}_{\alpha} \cap \mathbb{T}_{\beta}$ be an intersection point corresponding to the Spin^c class $\mathfrak{s} \in \text{Spin}^c(M)$. Suppose

$$\mathbf{y} \times \theta \in \mathbb{T}_{\alpha'} \cap \mathbb{T}_{\beta'} = (\mathbb{T}_{\alpha} \cap \mathbb{T}_{\beta}) \times (\alpha \cap \beta)$$

is a generator contributing to $df_{\mathbb{S}}(\mathbf{x})$, via $u' \in \mathcal{M}(\phi')$, where $\phi' \in \pi_2(\mathbf{x} \times \theta_{\alpha\beta}, \mathbf{y} \times \theta)$. Thus, $\mu(\phi') = 1$ and $u'(\phi') \neq 0$. The class ϕ' is the join of classes $\phi \in \pi_2(\mathbf{x}, \mathbf{y})$ (corresponding to the Heegaard diagram \mathcal{H}) and $\phi_S \in \pi_2(\theta_{\alpha\beta}, \theta)$ (corresponding to the Heegaard diagram \mathcal{H}_S), along a pair of necks corresponding to w_1 and w_2 which connect the two Heegaard diagrams. Further, $u'(\phi') \neq 0$ implies that $u(\phi) \neq 0$.

Let $|\theta|$ denote the number of intersection points in θ which are different from $\theta_{\alpha\beta}$. Thus, $|\theta| \in \{0, 1\}$. For a class ϕ' as above with $\mu(\phi') = 1$, we have

$$1 = \mu(\phi') = \mu(\phi) + \mu(\phi_S) - 2n_{w_1}(\phi_S) - 2n_{w_2}(\phi_S) = \mu(\phi) + |\theta|.$$

Since the path J' of almost complex structures is chosen close to the join of J and J_S , and $u(\phi) \neq 0$, Proposition 5.1 implies that every pseudo-holomorphic representative u' of ϕ' is in correspondence with a J -holomorphic curve $u \in \mathcal{M}(\phi)$ and a J_S -holomorphic curve $u_S \in \mathcal{M}(\phi_S)$, which are pre-glued.

If $\theta \neq \theta_{\alpha\beta}$, then $\mu(\phi) = 0$ and u is the constant map. It follows that $n_{w_i}(\phi_S) = n_{w_i}(\phi) = 0$ and ϕ_S corresponds to one of the two bigon connecting $\theta_{\alpha\beta}$ to $\theta_{\beta\alpha}$. The total contribution of such u' to $df_{\mathbb{S}}(\mathbf{x})$ is thus zero.

The remaining contributions to $df_{\mathbb{S}}(\mathbf{x})$ come from the classes ϕ' such that $\mu(\phi) = 1$, while $\theta = \theta_{\alpha\beta}$ and $n_{w_i}(\phi_S) = n_{w_i}(\phi) = k_i$ for $i = 1, 2$. We would like to show that the total contribution to $df_{\mathbb{S}}(\mathbf{x})$ from such u' is equal to the corresponding contribution from $u \in \mathcal{M}(\phi)$ to $d(\mathbf{x})$. It follows from Proposition 5.1, that if the necks connecting S to Σ are sufficiently stretched, then for $\phi' = \phi \star \phi_S$ the moduli space $\mathcal{M}(\phi')$ maybe identified with the fiber product $\mathcal{M}(\phi) \times_{\text{Sym}^{k_1}(\mathbb{D}) \times \text{Sym}^{k_2}(\mathbb{D})} \mathcal{M}(\phi_S)$. In particular, any $u' \in \mathcal{M}(\phi')$ corresponds to the degeneration $u \star u_S$ with $u \in \mathcal{M}(\phi)$ and $u_S \in \mathcal{M}(\phi_S)$ such that

$$\rho_{\Sigma}(u) = \rho_S(u_S) \in \text{Sym}^{k_1}(\mathbb{D}) \times \text{Sym}^{k_2}(\mathbb{D}),$$

where

$$\begin{aligned} \rho_{\Sigma} &= \rho_{w_1} \times \rho_{w_2} : \mathcal{M}(\phi) \rightarrow \text{Sym}^{k_1}(\mathbb{D}) \times \text{Sym}^{k_2}(\mathbb{D}) \quad \text{and} \\ \rho_S &= \rho_{w_1} \times \rho_{w_2} : \mathcal{M}(\phi_S) \rightarrow \text{Sym}^{k_1}(\mathbb{D}) \times \text{Sym}^{k_2}(\mathbb{D}) \end{aligned}$$

are the evaluation maps.

This reduces the proof to the first part of the following Lemma, which will be proved in Subsection 5.4. With this lemma in place, the proof of the proposition is complete. \square

Lemma 5.3. *Let α, β, γ denote three curves on \mathbb{P}^1 which are small Hamiltonian isotopes of one another and denote the corresponding top intersection points by $\theta_a \in \beta \cap \gamma$, $\theta_b \in \alpha \cap \gamma$ and $\theta_c \in \alpha \cap \beta$. Let w_1 and w_2 denote markings on the two domains in the complement of the isotopy regions. Let ϕ_{k_1, k_2} denote the set of Whitney disks $\phi \in \pi_2(\theta_c, \theta_c)$ with $n_{w_i}(\phi) = k_i$, $i = 1, 2$ and Δ_{k_1, k_2} denote the union of the triangle classes $\Delta \in \pi_2(\theta_c, \theta_a, \theta_b)$ with $n_{w_i}(\Delta) = k_i$, $i = 1, 2$. Then for generic*

$$(p_1, p_2) \in \text{Sym}^{k_1}(\mathbb{D}) \times \text{Sym}^{k_2}(\mathbb{D})$$

and a generic path of almost complex structures on \mathbb{P}^1 we have

$$\begin{aligned} (i) \quad n_{p_1, p_2}(\phi_{k_1, k_2}) &:= \# \{u \in \mathcal{M}(\phi_{k_1, k_2}) \mid \rho_{w_i}(u) = p_i, \quad i = 1, 2\} = 1 \quad \text{and} \\ (ii) \quad n_{p_1, p_2}(\Delta_{k_1, k_2}) &:= \# \{u \in \mathcal{M}(\Delta_{k_1, k_2}) \mid \rho_{w_i}(u) = p_i, \quad i = 1, 2\} = 1. \end{aligned}$$

5.4. Proof of Lemma 5.3. The proof is closely related to the proof of [OS08, Lemma 6.4]. We will prove the second claim. The first claim is in fact easier, and its proof is completely similar. The first step is to show that the number $n_{p_1, p_2}(\Delta_{k_1, k_2})$ does not depend on the generic choice of (p_1, p_2) . Given a generic path $\{(p_1^t, p_2^t)\}_{t \in [0, 1]}$ in $\text{Sym}^{k_1}(\mathbb{D}) \times \text{Sym}^{k_2}(\mathbb{D})$ connecting the generic points (p_1^0, p_2^0) and (p_1^1, p_2^1) , consider the moduli space

$$\{(u, t) \mid t \in [0, 1], \quad u \in \mathcal{M}(\Delta_{k_1, k_2}), \quad \rho_{w_i}(u) = p_i^t, \quad i = 1, 2\},$$

which is a smooth 1-dimensional moduli space with ends determined by the Gromov limits of its points. Picture \mathbb{D} as a Y shape domain, and assume that the complex structure is translation invariant as we move towards infinity in any of three directions corresponding to v_a, v_b and v_c . Three types of the boundary points correspond to a degenerations of the domain into a disk ϕ and a triangle class Δ_{ϕ} . Since the path $\{(p_1^t, p_2^t)\}_t$ remains in a compact subset of the domain, the disk ϕ can not contain any of the pre-images of w_1 or w_2 , i.e. $n_{w_1}(\phi) = n_{w_2}(\phi) = 0$. There are no holomorphic disks to θ_b with coefficient 0 at w_1 and w_2 . Thus, ϕ corresponds to the disks contributing to $\widehat{\partial}(\theta_a)$ or $\widehat{\partial}(\theta_c)$ which are all zero, i.e. the total number of such ends is always zero. The remaining ends correspond to

$$- \{u \in \mathcal{M}(\Delta_{k_1, k_2}) \mid \rho_{w_i}(u) = p_i^0, \quad i = 1, 2\} \prod \{u \in \mathcal{M}(\Delta_{k_1, k_2}) \mid \rho_{w_i}(u) = p_i^1, \quad i = 1, 2\},$$

implying the independence of $n_{p_1, p_2}(\Delta_{k_1, k_2})$ from the generic choice of (p_1, p_2) in the product $\text{Sym}^{k_1}(\mathbb{D}) \times \text{Sym}^{k_2}(\mathbb{D})$.

Consider one of the branches of the Y -shape domain \mathbb{D} , for instance the one corresponding to v_a , and identify the branch with $[0, 1] \times (0, \infty)$. Denote the projection over the second factor by $\pi_{\mathbb{R}}$. Choose the generic path (p_1^T, p_2^T) of points in $\text{Sym}^{k_1}(\mathbb{D}) \times \text{Sym}^{k_2}(\mathbb{D})$ so that p_1^T is a union of k_1 points $p_{1,1}^T, \dots, p_{1,k_1}^T$ in the above branch so that

$$\pi_{\mathbb{R}}(p_{1,1}^T) > T \quad \text{and} \quad \pi_{\mathbb{R}}(p_{1,i+1}^T) - \pi_{\mathbb{R}}(p_{1,i}^T) > T.$$

Similarly, assume that p_2^T is a union of k_2 points $p_{2,1}^T, \dots, p_{2,k_2}^T$ in the above branch so that

$$\pi_{\mathbb{R}}(p_{2,1}^T) - \pi_{\mathbb{R}}(p_{1,k_1}^T) > T \quad \text{and} \quad \pi_{\mathbb{R}}(p_{2,i+1}^T) - \pi_{\mathbb{R}}(p_{2,i}^T) > T.$$

One may then consider the ends of the smooth 1-dimensional moduli space

$$\mathcal{N} = \coprod_{T \in [1, \infty)} \{u \in \mathcal{M}(\Delta_{k_1, k_2}) \mid \rho_{w_i}(u) = p_i^T, \quad i = 1, 2\}.$$

Two types of boundary ends correspond to degenerations of u to a triangle and a disk ϕ which goes to θ_b or starts from θ_c . Since the path of points remains in a compact subset of the branch corresponding to vertices v_b and v_c , we find $n_{w_1}(\phi) = n_{w_2}(\phi) = 0$. There are no holomorphic disks to θ_b with coefficients 0 at w_1 and w_2 , and the disks ϕ which contribute to $\widehat{\partial}(\theta_c)$ come in canceling pairs. Such pairs correspond to pairs of points in the boundary of \mathcal{N} with canceling contributions. The remaining boundary components of \mathcal{N} are in correspondence with the points in union of

$$- \{u \in \mathcal{M}(\Delta_{k_1, k_2}) \mid \rho_{w_i}(u) = p_i^1, \quad i = 1, 2\}$$

and the product

$$\mathcal{M}(\Delta_{0,0}) \times \left(\prod_{i=1}^{k_1} \{u \in \mathcal{M}(\phi) \mid \rho_{w_1}(u) = t_{1,i}\} \right) \times \left(\prod_{i=1}^{k_2} \{u \in \mathcal{M}(\psi) \mid \rho_{w_1}(u) = t_{2,i}\} \right).$$

Here $\phi \in \pi_2(\theta_a, \theta_a)$ denotes the homotopy types of the two disks connecting θ_a to itself with boundary on $\beta \amalg \gamma$, $n_{w_1}(\phi) = 1$ and $n_{w_2}(\phi) = 0$. Similarly, $\psi \in \pi_2(\theta_a, \theta_a)$ denotes the homotopy types of the two disks connecting θ_a to itself with boundary on $\beta \amalg \gamma$, $n_{w_1}(\psi) = 0$ and $n_{w_2}(\psi) = 1$. Moreover, $t_{1,i}$ and $t_{2,i}$ are arbitrary point on $[0, 1] \times \mathbb{R}$. It is implied by [AE15, Lemma 7.3] that the total number of points (counted with sign) in this latter end of the moduli space is 1. Consequently, $n_{p_1^1, p_2^1}(\Delta_{k_1, k_2}) = 1$ and the proof is complete.

5.5. Invariance of the cobordism map for one-handles. Let $\mathcal{T} = [M, T, \mathbf{u}, \mathfrak{s}]$ be an \mathbb{A} -tangle and $\mathbb{S} \subset M \setminus T$ be a framed 0-sphere. As before, $\mathcal{C} = \mathcal{C}(\mathbb{S})$ denotes the parametrized \mathbb{A} -cobordism from \mathcal{T} to $\mathcal{T}' = \mathcal{T}(\mathbb{S})$, obtained by attaching a 1-handle to $\mathcal{T} \times [0, 1]$ along $\mathbb{S} \times \{1\}$.

Theorem 5.4. *For any \mathbb{A} -module \mathbb{M} , the chain map $f_{\mathbb{S}}^{\mathbb{M}}$ from Proposition 5.2 induces a homomorphism*

$$f_{\mathcal{C}}^{\mathbb{M}} : \text{HF}^{\mathbb{M}}(\mathcal{T}) \longrightarrow \text{HF}^{\mathbb{M}}(\mathcal{T}').$$

Proof. Any Heegaard surface for \mathcal{T} may be modified to intersect each component of \mathbb{S} in a disk, by an isotopy supported in a neighborhood of two arcs in M . So we may just consider Heegaard diagrams for \mathcal{T} that the underlying Heegaard surface satisfies in this property. From any Heegaard diagram \mathcal{H} for \mathcal{T} with such an underlying Heegaard surface Σ , one may construct a Heegaard diagram \mathcal{H}' for \mathcal{T}' as described in Section 5.1. Any choice of a path J of almost complex structures for the Heegaard surface Σ of \mathcal{T} gives a degenerate path of almost complex structures corresponding to the join of Σ and the standard model \bar{S} at w_1 and w_2 . This path may be perturbed to a path J' of almost complex structures corresponding to Σ' , the Heegaard surface for \mathcal{T}' . Let J_1 and J_2 be paths of almost complex structures for Σ and J'_1 and J'_2 be the corresponding paths for Σ' . It

follows from standard techniques (involving a path connecting different choices of paths of almost complex structures) that

$$f_{\mathbb{S}} \circ \Phi_{J_1 \rightarrow J_2} = \Phi_{J'_1 \rightarrow J'_2} \circ f_{\mathbb{S}}.$$

Let \mathcal{H}_0 and \mathcal{H}_1 be Heegaard diagrams for \mathcal{T} such that \mathcal{H}_1 is obtained from \mathcal{H}_0 by one Heegaard move (i.e. isotopy on an α or β curve, handleslide on an α or β curve, stabilization or destabilization) denoted by e . We need to prove that the diagram

$$\begin{array}{ccc} \mathrm{HF}^{\mathbb{M}}(\mathcal{H}_0) & \xrightarrow{f_{\mathbb{S}}} & \mathrm{HF}^{\mathbb{M}}(\mathcal{H}'_0) \\ \Phi_e \downarrow & & \Phi_{e'} \downarrow \\ \mathrm{HF}^{\mathbb{M}}(\mathcal{H}_1) & \xrightarrow{f_{\mathbb{S}}} & \mathrm{HF}^{\mathbb{M}}(\mathcal{H}'_1). \end{array}$$

is commutative. Here, Φ_e is the isomorphism associated with the Heegaard move, and \mathcal{H}'_i is the Heegaard diagram for \mathcal{T}' obtained from \mathcal{H}_i after joining it with $\mathcal{H}_S = (\mathbb{P}^1, \alpha, \beta, w_1, w_2)$ at w_1 and w_2 . Furthermore, \mathcal{H}'_1 is obtained from \mathcal{H}'_0 by a Heegaard move, denoted by e' .

When e is a stabilization or destabilization, the proof is straightforward, and the above diagram is in fact commutative in the level of chain complexes if the almost complex structure is chosen correctly. The remaining cases are thus the cases where e is an isotopy (which may pass over either of w_1 and w_2), or a handle slide.

We present the argument in the case where e is a β -isotopy or a handle-slide on β . Let γ be a collection of curves which is obtained from β by applying the Heegaard move e , followed by small Hamiltonian isotopies. Choose a small isotope γ of β as well. Let $\gamma' = \gamma \amalg \{\gamma\}$. There is a generator associated with the Heegaard diagram $(\Sigma, \beta, \gamma, \mathbf{u}, \mathfrak{s})$, denoted by Θ , which represents the homology class $\Theta_{\beta\gamma}$. Furthermore, $\Theta' = \Theta \times \{\theta_{\beta\gamma}\}$ generates the top homology class $\Theta_{\beta'\gamma'}$ in $\mathrm{HF}(\Sigma', \beta', \gamma', \mathbf{u}', \mathfrak{s}')$.

The Heegaard triple $(\Sigma, \alpha, \beta, \gamma, \mathbf{u}, \mathfrak{s})$ determines a holomorphic triangle map, and together with the generator Θ , this gives a chain map

$$f = f_{\alpha\beta\gamma} : \mathrm{CF}(\Sigma, \alpha, \beta, \mathbf{u}, \mathfrak{s}) \longrightarrow \mathrm{CF}(\Sigma, \alpha, \gamma, \mathbf{u}, \mathfrak{s}).$$

Similarly, the Heegaard triple $(\Sigma', \alpha', \beta', \gamma', \mathbf{u}', \mathfrak{s}')$ and the generator Θ' determine a chain map

$$f' = f_{\alpha'\beta'\gamma'} : \mathrm{CF}(\Sigma', \alpha', \beta', \mathbf{u}', \mathfrak{s}') \longrightarrow \mathrm{CF}(\Sigma', \alpha', \gamma', \mathbf{u}', \mathfrak{s}').$$

To complete the proof, it is enough to show that $f' \circ f_{\mathbb{S}} = f_{\mathbb{S}} \circ f$.

For this purpose, fix the generator \mathbf{x} of $\mathrm{CF}(\Sigma, \alpha, \beta, \mathbf{u}, \mathfrak{s})$ and suppose

$$\Delta' \in \pi_2(\mathbf{x} \times \theta_{\alpha\beta}, \Theta \times \theta_{\beta\gamma}, \mathbf{y} \times \theta)$$

is a triangle class contributing to $f' \circ f_{\mathbb{S}}$, where θ is one of the two intersection points in $\alpha \cap \gamma$. Δ' gives the triangle classes

$$\Delta \in \pi_2(\mathbf{x}, \Theta, \mathbf{y}) \quad \text{and} \quad \Delta_S \in \pi_2(\theta_{\alpha\beta}, \theta_{\beta\gamma}, \theta)$$

which support holomorphic representatives. Moreover we have

$$n_{w_i}(\Delta) = n_{w_i}(\Delta_S) \quad \text{for } i = 1, 2 \quad \text{and} \quad 0 = \mu(\Delta') = \mu(\Delta) + \mu(\Delta_S) - 2n_{w_1}(\Delta_S) - 2n_{w_2}(\Delta_S).$$

Since $\mu(\Delta_S) = |\theta| + 2n_{w_1}(\Delta_S) + 2n_{w_2}(\Delta_S)$ we find $\mu(\Delta') = \mu(\Delta) + |\theta|$. From here, we conclude that θ is the top generator $\theta_{\alpha\gamma}$ and that $\mu(\Delta) = 0$.

Let $k_i = n_{w_i}(\Delta_S)$ for $i = 1, 2$ and consider the evaluation maps

$$\begin{aligned} \rho_{\Sigma} &= \rho_{w_1} \times \rho_{w_2} : \mathcal{M}(\Delta) \rightarrow \mathrm{Sym}^{k_1}(\mathbb{D}) \times \mathrm{Sym}^{k_2}(\mathbb{D}) \quad \text{and} \\ \rho_S &= \rho_{w_1} \times \rho_{w_2} : \mathcal{M}(\Delta_S) \rightarrow \mathrm{Sym}^{k_1}(\mathbb{D}) \times \mathrm{Sym}^{k_2}(\mathbb{D}). \end{aligned}$$

If $u' \in \mathcal{M}(\Delta')$ corresponds to the degeneration $u \star u_S$ with $u \in \mathcal{M}(\Delta)$ and $u_S \in \mathcal{M}(\Delta_S)$, we find

$$\rho_{\Sigma}(u) = \rho_S(u_S) \in \mathrm{Sym}^{k_1}(\mathbb{D}) \times \mathrm{Sym}^{k_2}(\mathbb{D}).$$

There are several classes Δ_S with the property that $n_{w_i}(\Delta_S) = k_i$. Let Δ_{k_1, k_2} denote the set of all the above classes. We thus obtain a map

$$\iota_{\Delta'} : \mathcal{M}(\Delta') \longrightarrow \mathcal{M}(\Delta) \times_{\text{Sym}^{k_1}(\mathbb{D}) \times \text{Sym}^{k_2}(\mathbb{D})} \mathcal{M}(\Delta_{k_1, k_2}).$$

By the argument of Proposition 5.1, if the neck is sufficiently stretched and the paths of almost complex structures are generic $\iota_{\Delta'}$ is a bijection, reducing the proof to the second claim in Lemma 5.3. This completes the proof of Theorem 5.4. \square

5.6. Three-handles. Let $\mathcal{T} = [M, T, \mathbf{u}, \mathfrak{s}]$ be an \mathbb{A} -tangle as before, and $\mathbb{S} \subset M \setminus T$ be a framed 2-sphere. Further, assume that $\langle c_1(\mathfrak{s}), [a(\mathbb{S})] \rangle = 0$, where $a(\mathbb{S})$ is the attaching sphere of \mathbb{S} . Then, \mathbb{S} specifies an \mathbb{A} -cobordism

$$\mathcal{C} = \mathcal{C}(\mathbb{S}) = [W(\mathbb{S}), F(\mathbb{S}) = T \times [0, 1], \mathbf{u}_F : \pi_0(T) = \pi_0(F(\mathbb{S})) \rightarrow \mathbb{A}, \mathfrak{t}_{\mathfrak{s}}],$$

where $W(\mathbb{S})$ is obtained from $M \times [0, 1]$ by attaching a 3-handle along the framed sphere $\mathbb{S} \times \{1\} \subset M \times \{1\}$. The Spin^c class $\mathfrak{t} = \mathfrak{t}_{\mathfrak{s}}$ is the Spin^c structure on $W = W(\mathbb{S})$ determined by \mathfrak{s} i.e. $\mathfrak{t}|_M = \mathfrak{s}$. The cobordism $\mathcal{C}(\mathbb{S})$ connects \mathcal{T} to

$$\mathcal{T}' = \mathcal{T}'(\mathbb{S}) = [M' = M(\mathbb{S}), T' = T \times \{1\}, \mathbf{u}' : \pi_0(T') = \pi_0(T) \rightarrow \mathbb{A}, \mathfrak{s}' = \mathfrak{t}|_{M'}].$$

If we reverse the cobordism $\mathcal{C}(\mathbb{S})$ we obtain an \mathbb{A} -cobordism from \mathcal{T}' to \mathcal{T} which corresponds to attaching a 1-handle.

Consider a Heegaard surface Σ for M that cuts the framed sphere \mathbb{S} in a cylinder $S \subset \Sigma$ with boundary components C_1 and C_2 . A Heegaard surface Σ' for M' is then obtained from Σ by removing S , and gluing a pair of disks with centers w_1 and w_2 to C_1 and C_2 , respectively. Let $\mathcal{H}' = (\Sigma', \boldsymbol{\alpha}', \boldsymbol{\beta}', \mathbf{u}' : \mathbf{z} \rightarrow \mathbb{A}, \mathfrak{s}')$ be a Heegaard diagram for \mathcal{T}' . Consider a pair of Hamiltonian isotopic curves α and β on S that are both isotopic to the core of the cylinder and cut each other transversely in $\theta_{\alpha\beta}$ and $\theta_{\beta\alpha}$. Then,

$$\mathcal{H} = (\Sigma, \boldsymbol{\alpha} = \boldsymbol{\alpha}' \cup \{\alpha\}, \boldsymbol{\beta} = \boldsymbol{\beta}' \cup \{\beta\}, \mathbf{u} : \mathbf{z} \rightarrow \mathbb{A}, \mathfrak{s})$$

is a Heegaard diagram for \mathcal{T} , provided that we use the stronger form of admissibility for \mathcal{H}' , as discussed in [AE15, Remark 4.6].

Choose a generic path J' of almost complex structures associated with the surface Σ' . On the sphere \bar{S} , obtained by attaching a pair of disks with centers w_1 and w_2 to S , consider a complex structure J_S , so that (\bar{S}, w_1, w_2) is identified with $(\mathbb{P}^1, 0, \infty)$. Then, let J be a generic path of almost complex structures on Σ sufficiently close to the join of J and J_S . The chain map

$$f_{\mathbb{S}} : \text{CF}_J(\mathcal{H}) \longrightarrow \text{CF}_{J'}(\mathcal{H}').$$

is defined as follows. For a generator

$$\mathbf{x} = \mathbf{x}' \times \theta \in \mathbb{T}_{\alpha} \cap \mathbb{T}_{\beta} = (\mathbb{T}_{\alpha'} \cap \mathbb{T}_{\beta'}) \times (\alpha \cap \beta)$$

let

$$f_{\mathbb{S}}(\mathbf{x}) = \begin{cases} \mathbf{x}' & \text{if } \theta = \theta_{\beta\alpha} \\ 0 & \text{otherwise} \end{cases}$$

An argument, which is basically the dual of the argument used for 1-handles implies the following theorem.

Theorem 5.5. *With the above notation fixed, $f_{\mathbb{S}}$ is a chain map, and for any \mathbb{A} -module \mathbb{M} , it induces a natural homomorphism*

$$f_{\mathbb{S}}^{\mathbb{M}} = f_{\mathcal{C}}^{\mathbb{M}} : \text{HF}^{\mathbb{M}}(\mathcal{T}) \longrightarrow \text{HF}^{\mathbb{M}}(\mathcal{T}').$$

6. FRAMED ARCS, FRAMED KNOTS AND COBORDISM MAPS

6.1. Special tangles corresponding to cobordisms. Assume $\mathcal{C} = [W, F, \mathfrak{t}, \mathfrak{u}_F]$ is an \mathbb{A} -cobordism from the \mathbb{A} -tangle $\mathcal{T} = [M, T, \mathfrak{s}, \mathfrak{u}]$ to another \mathbb{A} -tangle $\mathcal{T}' = [M', T', \mathfrak{s}', \mathfrak{u}']$. In this subsection we introduce an \mathbb{A} -tangle \mathcal{T}_F associated with \mathcal{C} playing the role of $\#^k S^1 \times S^2$ in defining the chain maps in Heegaard Floer theory. The important feature of \mathcal{T}_F is the existence of a distinguished generator $\Theta_F \in \text{HF}(\mathcal{T}_F)$, which plays the role of the *top generator* in $\text{HF}^-(\#^k S^1 \times S^2)$.

Denote the stable cobordism (W, F) by \mathcal{W} . Recall that the positive boundary of \mathcal{W} , denote by $\partial^+ \mathcal{W} = (M^+, T^+)$, is identified with the product tangle

$$(M^+, T^+) = (\partial^+ M \times [0, 1], \partial^+ T \times [0, 1]).$$

Thus, denote

$$(\partial^+ M^+, \partial^+ T^+) = (\partial^+ M \times \{1\}, \partial^+ T \times \{1\}) \quad \text{and} \quad (\partial^- M^+, \partial^- T^+) = (\partial^+ M \times \{0\}, \partial^+ T \times \{0\}).$$

Let $J \subset F$ be a properly embedded, simple arc such that $\partial J \subset T^+$. Associated with J we define a pair (M_J, T_J) by doing surgery on (M^+, T^+) at points $J \cap T^+$ with the framing induced by F . More precisely, let $\text{nd}(J) \subset W$ be a small tubular neighborhood of J in W . The intersection $F \cap \partial \text{nd}(J)$ induces a framing on $\partial \text{nd}(J)$. Using this framing, we define

$$M_J = (M^+ \setminus M^+ \cap \text{nd}(J)) \cup \partial \text{nd}(J) \quad \text{and} \quad T_J = \partial(F \setminus \text{nd}(J)) \setminus (\partial F \cap (\partial W \setminus M^+)).$$

If the end points of J are on distinct connected components of T^+ then (M_J, T_J) is a balanced tangle. In this case, consider a small product neighborhood of M^+ , and an identification of it with $M^+ \times [0, \epsilon]$, such that $F \cap (M^+ \times [0, \epsilon]) = T^+ \times [0, \epsilon]$. Denote the 4-manifold obtained from attaching the one-handle $\text{nd}(J)$ to $M^+ \times [0, \epsilon]$ by W_J . Let $F_J = F \cap W_J$ and note that $\mathcal{W}_J = (W_J, F_J)$ is a cobordism from (M^+, T^+) to (M_J, T_J) .

Definition 6.1. A set $J = \{J_1, \dots, J_n\}$ of pairwise disjoint, properly embedded, simple arcs on F satisfying $\partial J_i \subset T^+$ for $i = 1, \dots, n$ is called a *spanning* set if each connected component of $F \setminus (\bigsqcup_{i=1}^n J_i)$ is a disc and contains exactly one connected component of T and one connected component of T' .

Consider a spanning set $J = \{J_1, \dots, J_n\}$ of arcs on F . After doing surgery on (M^+, T^+) along the elements of J , we get a balanced tangle, which is denoted by (M_J, T_J) . In particular, if J is a single arc, $(M_{\{J\}}, T_{\{J\}}) = (M_J, T_J)$. The diffeomorphism type of (M_J, T_J) does not change under an *arc slide* move, i.e. sliding one foot of an arc J_i over another arc J_j , while fixing the rest of the arcs.

Lemma 6.1. *The diffeomorphism type of the tangle (M_J, T_J) is independent of the choice of J .*

Proof. Associated with any spanning set J of arcs on F , we may define a Morse function $g : F \rightarrow [0, 1]$ and a gradient like vector field ξ , such that

- (1) $g|_{F \cap \partial^- W} \equiv 0$, $g|_{F \cap \partial^+ W} \equiv 1$ and g has no critical point in a neighborhood of ∂F .
- (2) All critical points of g have index one.
- (3) The arcs in J are the unstable manifolds of the critical points of g .

It follows from [GK15, Theorem 4.5] that any two Morse data (g, ξ) and (g', ξ') as above, can be connected by a sequence of critical point switches and isotopies of the gradient-like vector fields. Thus, the corresponding spanning sets can be connected by a sequence of arc slides. So, (M_J, T_J) does not depend on the choice of J . \square

We may thus denote the balanced tangle (M_J, T_J) by (M_F, T_F) and the cobordism \mathcal{W}_J from (M^+, T^+) to (M_F, T_F) by \mathcal{W}_F .

Definition 6.2. A spanning set $J = \{J_1, \dots, J_n\}$ of arcs is called *ordered*, if

- (1) endpoints of each J_i lie on distinct components of T^+ ,

- (2) if for some $j < k$ an endpoint e_j of J_j and an endpoint e_k of J_k are on the same component of T^+ , then $\pi(e_j) > \pi(e_k)$. Here, $\pi : T^+ = \coprod_{i=1}^{\kappa} (\{p_i\} \times [0, 1]) \rightarrow [0, 1]$ denotes the projection on $[0, 1]$.

If a spanning set $J = \{J_1, \dots, J_n\}$ of arcs is ordered, doing surgery along J_1, \dots, J_i on (M^+, T^+) would result in a balanced tangle, for any $1 \leq i \leq n$.

Lemma 6.2. *For any stable cobordism (W, F) , there is an ordered spanning set of arcs on F .*

Proof. The proof is straightforward. \square

The \mathbb{A} -coloring \mathbf{u}_F induces an \mathbb{A} -coloring $\mathbf{u}_F \circ \iota$ on (M_F, T_F) , where $\iota : \pi_0(T_F) \rightarrow \pi_0(F)$ is defined by inclusion. Abusing the notation we denote this coloring by \mathbf{u}_F . Let $H_i \in \mathbb{H}_2(M_F, \mathbb{Z})$ be the homology class represented by the belt sphere of the attached 1-handle corresponding to J_i . Moreover, associated with every component $\partial_k^+ M$ of $\partial^+ M$, with $k = 1, \dots, \ell$, we obtain a homology class $H'_k \in \mathbb{H}_2(M_F, \mathbb{Z})$. Consider the Spin^c class $\mathfrak{s}_0 \in \text{Spin}^c(M_F)$ such that $\langle c_1(\mathfrak{s}_0), H_i \rangle = \langle c_1(\mathfrak{s}_0), H'_k \rangle = 0$ for every $1 \leq i \leq m$ and every $1 \leq k \leq \ell$. We then define $\mathcal{T}_F = [M_F, T_F, \mathfrak{s}_0, \mathbf{u}_F]$.

Similar to \mathcal{T}_F , we define another tangle \mathcal{T}_F^b as follows. Let us assume that $\partial^+ T = \{p_1, \dots, p_\kappa\} \subset \partial^+ M$ and correspondingly, T^+ is a union of components

$$T^+ = \coprod_{i=1}^{\kappa} T_i^+ = \coprod_{i=1}^{\kappa} (\{p_i\} \times [0, 1]) \subset M^+.$$

For every $1 \leq i \leq \kappa$ consider a point $\bar{p}_i \in \partial^+ M$ close to p_i and let $\bar{T}_i^+ = \bar{p}_i \times [0, 1]$ and $\bar{T}^+ := \coprod_{i=1}^{\kappa} \bar{T}_i^+$ in M^+ . Setting $T_F^b = T_F \amalg \bar{T}^+$ one gets a balanced tangle (M_F, T_F^b) .

Suppose that $F = \coprod_{i=1}^m F_i$ and $\partial^+ M = \coprod_{k=1}^{\ell} \partial_k^+ M$. Associated to each component $\partial_k^+ M$ of $\partial^+ M$, we define a monomial

$$\mathbf{w}_k = \prod_{p_j \in \partial_k^+ M} (\mathbf{u}(p_j) \mathbf{v}_j) \in \mathbb{F}[\mathbf{u}_1, \dots, \mathbf{u}_m, \mathbf{v}_1, \dots, \mathbf{v}_\kappa]$$

where $\mathbf{u}(p_j) = \mathbf{u}_i$ if $p_j \in F_i$. Denote the genus of $\partial_k^+ M$ by g_k . With this notation fixed, let

$$\mathbb{A}_F^b := \frac{\mathbb{F}[\mathbf{u}_1, \dots, \mathbf{u}_m, \mathbf{v}_1, \dots, \mathbf{v}_\kappa]}{\langle \mathbf{w}_k \mid g_k > 0, k = 1, \dots, \ell \rangle}.$$

The map $\mathbf{u}_F^b : \pi_0(T_F^b) \rightarrow \mathbb{A}_F^b$ defined by

$$\begin{cases} \mathbf{u}_F^b(\bar{T}_j^+) = \mathbf{v}_j & 1 \leq j \leq \kappa \\ \mathbf{u}_F^b(T_F^j) = \mathbf{u}(p_j) & 1 \leq j \leq \kappa, \end{cases}$$

is an \mathbb{A}_F^b -coloring of (M_F, T_F^b) . Here, T_F^j denotes the component of T_F that intersects $\partial^+ M$ in p_j . As a result, we get an \mathbb{A}_F^b -tangle $\mathcal{T}^b = [M_F, T_F^b, \mathfrak{s}_0, \mathbf{u}_F^b]$.

Remark 6.3. *Let \mathbb{A} denotes the \mathbb{Z} -algebra associated with the sutured manifold corresponding to (M_F, T_F^b) , see Section 2.1. Then \mathbb{A}_F^b is the quotient of $\mathbb{A} \otimes \mathbb{F}$ by the ideal generated by the binomials $\mathbf{u}_i - \mathbf{u}_j$ for all i and j , so that T_F^i and T_F^j lie on the boundary of the same component of F .*

The algebra \mathbb{A} has a natural \mathbb{A}_F^b -module structure given by the homomorphism $\phi : \mathbb{A}_F^b \rightarrow \mathbb{A}$ defined as

$$\begin{cases} \phi(\mathbf{u}_i) = \mathbf{u}_F(F_i) & 1 \leq i \leq m \\ \phi(\mathbf{v}_j) = 1 & 1 \leq j \leq \kappa. \end{cases}$$

Further, considering this module structure on \mathbb{A} it is straightforward that

$$\text{HF}^{\mathbb{A}}(\mathcal{T}^b) = \text{HF}(\mathcal{T}_F).$$

6.2. The distinguished generator. For every $1 \leq i \leq \kappa$, consider a product disk $(D_i, \partial D_i)$ in the balanced tangle $(M^+, T^+ \amalg \bar{T}^+)$ such that

$$\bar{T}_i^+ \amalg -T_i^+ \subset \partial D_i \quad \text{and} \quad \partial D_i \setminus (\bar{T}_i^+ \amalg -T_i^+) \subset \partial M^+.$$

Abusing the notation, we denote the intersection of D_i with M_F by D_i as well. Let $D = \amalg_{i=1}^{\kappa} D_i$. For every $1 \leq j \leq n$, we may attach an oriented one handle D'_j (i.e. a band) to D such that $D'_j \subset M_F$ is embedded in the one handle associated with J_j and

$$\partial D'_j \setminus (\partial D'_j \cap D) \subset F.$$

Denote the resulting embedded, oriented surface in (M_F, T_F^b) by F' . Note that

$$(F', \partial F') \subset (M_F, \partial M_F \cup T_F^b)$$

and that this pair is uniquely determined up to isotopy.

Let (X_F, τ_F^b) be the balanced sutured manifold associated with the tangle (M_F, T_F^b) . The surface $F' \cap X_F \subset X_F$ is a decomposing surface for (X_F, τ_F^b) , in the sense of [Juh08, Definition 2.7]. It is straightforward to check that this surface decomposes (X_F, τ_F^b) into a product sutured manifold. Thus, there exists a unique relative Spin^c structure $\underline{\mathfrak{s}}_{F'} \in \text{Spin}^c(X_F, \tau_F^b)$ which is *outer* with respect to F' . Recall that $\underline{\mathfrak{s}} \in \text{Spin}^c(X_F, \tau_F^b)$ is called *outer* with respect to F' , if it is represented by a unit vector field v on X_F such that $v_p \neq -(\nu_{F'})_p$ for every $p \in F'$. Here $\nu_{F'}$ is the unit normal vector field of F' with respect to some Riemannian metric on X_F , See [Juh08, Definition 1.1]. Note that $[\underline{\mathfrak{s}}_{F'}] = \mathfrak{s}_0$.

If the components $T_F^{j_1}$ and $T_F^{j_2}$ of T_F lie on the same component F_i of F , then

$$[\tau_F^{j_1}] = [\tau_F^{j_2}] \in \mathbb{H}_1(X_F, \mathbb{Z})$$

where τ_F^j denotes the suture associated with T_F^j . Thus, for any component F_i of F , there is a well-defined homology class $h_i = [\tau_F^j] \in \mathbb{H}_1(X_F, \mathbb{Z})$ where $T_F^j \subset F_i$. As a result, the algebra \mathbb{A}_F^b admits a filtration by $\mathbb{H} = \mathbb{H}^2(X_F, \partial X_F, \mathbb{Z})$, which is defined by

$$\begin{aligned} \chi : G(\mathbb{A}_F^b) &\rightarrow \mathbb{H} = \mathbb{H}^2(X_F, \partial X_F, \mathbb{Z}) \\ \chi\left(\prod_{i=1}^m \mathbf{u}_i^{a_i} \prod_{j=1}^{\kappa} \mathbf{v}_j^{b_j}\right) &:= \sum_{i=1}^m a_i \text{PD}(h_i) + \sum_{j=1}^{\kappa} b_j \text{PD}(\bar{\tau}_j^+) \end{aligned}$$

where $\bar{\tau}_j^+$ is the suture corresponding to $\bar{T}_j^+ \subset T_F^b$. Therefore, for every $\mathfrak{s} \in \text{Spin}^c(M_F)$

$$\text{CF}(M_F, T_F^b, \mathbf{u}_F^b, \mathfrak{s})$$

may be decomposed into sub-complexes associated with relative Spin^c structures. More precisely, let $\mathcal{H} = (\Sigma, \boldsymbol{\alpha}, \boldsymbol{\beta}, \mathbf{u}_F^b : \mathbf{z} \amalg \bar{\mathbf{z}} \rightarrow \mathbb{A}_F^b, \mathfrak{s}_0)$ be an \mathbb{A}_F^b -diagram for \mathcal{T}_F^b , where $\mathbf{z} = \{z_1, \dots, z_{\kappa}\}$ and $\bar{\mathbf{z}} = \{\bar{z}_1, \dots, \bar{z}_{\kappa}\}$, while $z_i = T_F^i \cap \Sigma$ and $\bar{z}_i = \bar{T}_i^+ \cap \Sigma$. Then

$$\text{CF}(\Sigma, \boldsymbol{\alpha}, \boldsymbol{\beta}, \mathbf{u}_F^b, \mathfrak{s}_0) = \bigoplus_{\underline{\mathfrak{s}} \in \mathfrak{s}_0 \subset \text{Spin}^c(M_F, T_F^b)} \text{CF}(\Sigma, \boldsymbol{\alpha}, \boldsymbol{\beta}, \mathbf{u}_F^b, \underline{\mathfrak{s}})$$

and $\text{CF}(\Sigma, \boldsymbol{\alpha}, \boldsymbol{\beta}, \mathbf{u}_F^b, \underline{\mathfrak{s}})$ is generated by the elements \mathbf{u}, \mathbf{x} , where $\mathbf{u} \in G(\mathbb{A}_F^b)$ is a monomial in \mathbb{A}_F^b and $\mathbf{x} \in \mathbb{T}_{\alpha} \cap \mathbb{T}_{\beta}$ is an intersection point satisfying

$$\underline{\mathfrak{s}}(\mathbf{u}, \mathbf{x}) := \underline{\mathfrak{s}}(\mathbf{x}) + \chi(\mathbf{u}) = \underline{\mathfrak{s}}.$$

For a relative class $\underline{\mathfrak{s}} \in \mathfrak{s}_0$, let

$$\mathbf{u} = \prod_{i=1}^m \mathbf{u}_i^{a_i} \prod_{j=1}^{\kappa} \mathbf{v}_j^{b_j} \quad \text{and} \quad \mathbf{u}' = \prod_{i=1}^m \mathbf{u}_i^{c_i} \prod_{j=1}^{\kappa} \mathbf{v}_j^{d_j}$$

be non-zero monomials in $G(\mathbb{A}_F^b)$ and $\mathbf{x}, \mathbf{y} \in \mathbb{T}_\alpha \cap \mathbb{T}_\beta$ be intersection points such that $\underline{\mathfrak{s}}(\mathbf{u}, \mathbf{x}) = \underline{\mathfrak{s}}(\mathbf{u}', \mathbf{y}) = \underline{\mathfrak{s}}$. Then, we say $\phi \in \pi_2(\mathbf{x}, \mathbf{y})$ connects \mathbf{u}, \mathbf{x} to \mathbf{u}', \mathbf{y} if

$$\begin{cases} a_i + \sum_{T_F^j \subset F_i} n_{z_j}(\phi) = c_i & 1 \leq i \leq m \\ b_j + n_{\bar{z}_j}(\phi) = d_j & 1 \leq j \leq \kappa. \end{cases}$$

Moreover, we define the relative grading of \mathbf{u}, \mathbf{x} and \mathbf{u}', \mathbf{y} by

$$\text{gr}(\mathbf{u}, \mathbf{x}, \mathbf{u}', \mathbf{y}) = \mu(\phi)$$

where $\phi \in \pi_2(\mathbf{x}, \mathbf{y})$ is a disk connecting \mathbf{u}, \mathbf{x} to \mathbf{u}', \mathbf{y} .

Lemma 6.4. *The relative grading gr is well-defined and is independent of the choice of ϕ . It induces a relative grading on the chain complex $\text{CF}(M_F, T_F^b, \mathbf{u}_F^b, \underline{\mathfrak{s}})$ and the differential lowers this grading by one.*

Proof. Suppose $\phi, \phi' \in \pi_2(\mathbf{x}, \mathbf{y})$ connect \mathbf{u}, \mathbf{x} to \mathbf{u}', \mathbf{y} . Then, $\mathcal{D} = \mathcal{D}(\phi) - \mathcal{D}(\phi')$ is a periodic domain such that

$$\sum_{T_F^j \subset F_i} n_{z_j}(\mathcal{D}) = 0 \quad \text{and} \quad n_{\bar{z}_j}(\mathcal{D}) = 0$$

for any i and j . Thus $\mathcal{D} = \sum_{i=1}^n m_i \mathcal{P}_i$ where \mathcal{P}_i is the periodic domain associated with H_i . Since, $\langle c_1(\mathfrak{s}_0), H_i \rangle = 0$ for any i ,

$$\mu(\phi) - \mu(\phi') = \langle c_1(\mathfrak{s}_0), H(\mathcal{D}) \rangle = 0.$$

□

Proposition 6.5. *With respect to the relative grading defined above, the top-dimensional homology group in $\text{HF}(M_F, T_F^b, \mathbf{u}_F^b, \underline{\mathfrak{s}}_{F'})$ is isomorphic to \mathbb{F} . If Θ_F^b denotes the generator of this homology group, then for the homomorphism*

$$\phi : \text{HF}(M_F, T_F^b, \mathbf{u}_F^b, \underline{\mathfrak{s}}_{F'}) \longrightarrow \text{HF}^{\mathbb{F}}(M_F, T_F^b, \mathbf{u}_F^b, \underline{\mathfrak{s}}_{F'}) = \text{SFH}(X_F, \tau_F^b, \underline{\mathfrak{s}}_{F'}) = \mathbb{F},$$

we have $\phi(\Theta_F^b) = 1$. Here, \mathbb{F} is an \mathbb{A}_F^b -module with trivial module structure and the homomorphism ϕ is induced from the surjection $\mathbb{A}_F^b \rightarrow \mathbb{F}$, which sends all variables to zero.

Proof. Let $\pi : T^+ = \prod_{i=1}^{\kappa} (\{p_i\} \times [0, 1]) \rightarrow [0, 1]$ denote the projection on $[0, 1]$. Consider an ordered set of spanning arcs $J = \{J_1, \dots, J_n\}$ on F . The result of surgery on $(M^+, T^+ \amalg \bar{T}^+)$ along J_1, \dots, J_i is a balanced tangle for any i , denoted by $(M^i, T^i \amalg \bar{T}^i)$. Note that $\bar{T}^i = \bar{T}^+$ for any i , and $(M^n, T^n \amalg \bar{T}^n) = (M_F, T_F^b)$.

Let \mathfrak{s}_0^i denote the Spin^c structure on M^i such that for any $1 \leq j \leq i$ we have $\langle c_1(\mathfrak{s}_0^i), H_j \rangle = 0$ and for $1 \leq k \leq \ell$ we have $\langle c_1(\mathfrak{s}_0^i), H_k' \rangle = 0$. Thus, $\mathfrak{s}_0^i = \mathfrak{s}_0$. Assume that the components of $T^i = \prod_{j=1}^{\kappa} T_j^i$ are labeled such that $T_j^i \cap \partial^+ M = \{p_j\}$. Inductively, we define an \mathbb{F} -algebra \mathbb{A}^i and a map $\mathbf{u}^i : \pi_0(T^i \amalg \bar{T}^i) \rightarrow \mathbb{A}^i$, such that $\mathcal{T}^i = [M^i, T^i \amalg \bar{T}^i, \mathfrak{s}_0^i, \mathbf{u}^i]$ becomes an \mathbb{A}^i -tangle. For $i = 0$, we have $(M^0, T^0 \amalg \bar{T}^0) = (M^+, T^+ \amalg \bar{T}^+)$. Let

$$\mathbb{A}^0 := \frac{\mathbb{Z}_2[\mathbf{v}'_1, \dots, \mathbf{v}'_{\kappa}, \mathbf{v}_1, \dots, \mathbf{v}_{\kappa}]}{\langle \mathbf{u}^k \mid g_k > 0 \rangle}$$

where $\mathbf{u}^k = \prod_{p_j \in \partial_k^+ M} (\mathbf{v}_j \mathbf{v}'_j)$. An \mathbb{A}^0 -coloring $\mathbf{u}^0 : \pi_0(T^0 \amalg \bar{T}^0) \rightarrow \mathbb{A}^0$ is defined as

$$\mathbf{u}^0(T_j^0) = \mathbf{v}'_j \quad \text{and} \quad \mathbf{u}^0(\bar{T}_j^0) = \mathbf{v}_j \quad \text{for every } 1 \leq j \leq \kappa.$$

Then, if J_i connects T_a^{i-1} and T_b^{i-1} , we define

$$\mathbb{A}^i := \frac{\mathbb{A}^{i-1}}{\langle \mathbf{u}^{i-1}(T_a^{i-1}) - \mathbf{u}^{i-1}(T_b^{i-1}) \rangle}$$

and $\mathbf{u}^i : \pi_0(T^i \amalg \bar{T}^i) \rightarrow \mathbb{A}^i$ is the map induced by \mathbf{u}^{i-1} . Note that $\mathbb{A}^n = \mathbb{A}_F^b$.

We may also construct an \mathbb{A}^i -diagram

$$\mathcal{H}^i = (\Sigma^i, \boldsymbol{\alpha}^i, \boldsymbol{\beta}^i, \mathbf{u}^i : \mathbf{z}^i \amalg \bar{\mathbf{z}}^i \rightarrow \mathbb{A}^i, \mathfrak{s}_0^i)$$

for \mathcal{T}^i , inductively. For $i = 0$, \mathcal{T}^0 is a product tangle so let $\Sigma^0 = \partial^+ M \times \{1/2\}$, $\boldsymbol{\alpha}^0 = \boldsymbol{\beta}^0 = \emptyset$, $\mathbf{z} = \{p_1, \dots, p_\kappa\} \times \{1/2\}$ and $\bar{\mathbf{z}} = \{\bar{p}_1, \dots, \bar{p}_\kappa\} \times \{1/2\}$. Given an \mathbb{A}^{i-1} -diagram \mathcal{H}^{i-1} for \mathcal{T}^{i-1} , we construct an \mathbb{A}^i -diagram for \mathcal{T}^i as follows. As before, suppose J_i connects T_a^{i-1} to T_b^{i-1} .

- (1) The Heegaard surface Σ^i is obtained from Σ^{i-1} by adding a one-handle with feet near z_a and z_b , where $z_a = T_{\bullet}^{i-1} \cap \Sigma^{i-1}$ for $\bullet = a, b$.
- (2) $\boldsymbol{\alpha}^i = \boldsymbol{\alpha}^{i-1} \cup \{\alpha_i\}$ where α_i is the core of the attached one-handle.
- (3) $\boldsymbol{\beta}^i = \boldsymbol{\beta}^{i-1} \cup \{\beta_i\}$ where β_i is a Hamiltonian translate of α_i , intersecting α_i in a pair of canceling intersection points. The area bounded between α_i and β_i gives a 2-chain $\mathcal{P} = D_i^+ - D_i^-$ with $\partial\mathcal{P} = \alpha_i - \beta_i$, the components D_i^+ and D_i^- of $\Sigma^i - \boldsymbol{\alpha}^i - \boldsymbol{\beta}^i$ are bigons such that one of them intersects \mathbf{z} in z_a while the other one intersects \mathbf{z} in z_b .
- (4) $\mathbf{z}^i = \mathbf{z}^{i-1}$ and $\bar{\mathbf{z}}^i = \bar{\mathbf{z}}^{i-1}$.

As a result, we get an \mathbb{A}_F^b -diagram

$$\mathcal{H} := \mathcal{H}^n = (\Sigma, \boldsymbol{\alpha} = \{\alpha_1, \dots, \alpha_n\}, \boldsymbol{\beta} = \{\beta_1, \dots, \beta_n\}, \mathbf{u}_F^b : \mathbf{z} \amalg \bar{\mathbf{z}} \rightarrow \mathbb{A}_F^b, \mathfrak{s}_0)$$

for \mathcal{T}^b . Any pair of curves (α_i, β_i) intersect in a pair of points x_i^+ and x_i^- , so that the bi-gons D_i^+ and D_i^- connect x_i^+ to x_i^- . Thus, corresponding to any map $\epsilon : \{1, \dots, n\} \rightarrow \{+, -\}$ we have an intersection point

$$\mathbf{x}^\epsilon = \{x_1^{\epsilon(1)}, \dots, x_n^{\epsilon(n)}\} \in \mathbb{T}_\alpha \cap \mathbb{T}_\beta.$$

By an argument similar to the argument of Proposition 5.2, the map

$$f_i : \text{CF}(\Sigma^{i-1}, \boldsymbol{\alpha}^{i-1}, \boldsymbol{\beta}^{i-1}, \mathbf{u}^{i-1}, \mathfrak{s}_0^{i-1}) \otimes \mathbb{A}^i \rightarrow \text{CF}(\Sigma^i, \boldsymbol{\alpha}^i, \boldsymbol{\beta}^i, \mathbf{u}^i, \mathfrak{s}_0^i)$$

which is defined by $f_i(\mathbf{y}) = \mathbf{y} \times \{x_i^+\}$, is a chain map if the path of almost complex structures is chosen correctly. In particular, the intersection point $\theta^+ := \{x_1^+, \dots, x_n^+\}$ is closed in the chain complex

$$\text{CF}(\Sigma, \boldsymbol{\alpha}, \boldsymbol{\beta}, \mathbf{u}_F^b, \mathfrak{s}_0) = \text{CF}(\mathcal{T}^b),$$

i.e. we have $\partial\theta^+ = 0$.

For every $1 \leq i \leq n$, let $(F'_i, \partial F'_i) \subset (M^i, \partial M^i \cup T^i \cup \bar{T}^i)$ denote the embedded, oriented surface obtained from D by attaching the embedded one handles D'_1, \dots, D'_i . Each F'_i is then a decomposing surface in $(M^i, T^i \amalg \bar{T}^i)$. We may inductively construct a closed subsurface $P^i \subset \Sigma^i$ such that the Heegaard diagram \mathcal{H}^i , together with P^i , is a diagram adapted to F'_i in the sense of [Juh08, Definition 4.3]. More precisely, P^i is a closed subsurface of Σ^i such that the boundary of P^i is a union of polygons, whose vertices are $P^i \cap (\mathbf{z} \amalg \bar{\mathbf{z}})$ and its edges are decomposed as $\partial P^i = A^i \cup B^i$ where

$$A^i \cap B^i \subset \mathbf{z} \amalg \bar{\mathbf{z}}, \quad \boldsymbol{\alpha}^i \cap B^i = \emptyset \quad \text{and} \quad \boldsymbol{\beta}^i \cap A^i = \emptyset.$$

Finally, the equivalence class of F'_i is given by smoothing the corners of

$$(P^i \times \{1/2\}) \cup (A^i \times [1/2, 1]) \cup (B^i \times [0, 1/2]) \subset (M^i, T^i \amalg \bar{T}^i).$$

For every i , suppose that J_i connects $T_{a_i}^{i-1}$ to $T_{b_i}^{i-1}$. For $i = 1$, F'_1 is obtained from D by attaching a one-handle to $T_{a_1}^0$ and $T_{b_1}^0$. Thus, P^1 is a union of a rectangle whose vertices are $z_{a_1}, z_{b_1}, \bar{z}_{a_1}$ and \bar{z}_{b_1} and contains the intersection point x_1^- , together with $n - 2$ bigons disjoint from $\boldsymbol{\alpha}^1$ and $\boldsymbol{\beta}^1$, whose vertices are z_j and \bar{z}_j for $j \neq a_1, b_1$. For any $i > 1$, the subsurface P^i may be constructed from P^{i-1} by attaching an embedded one-handle in Σ^i which intersects α_i and β_i and contains x_i^- , as illustrated in Figure 5.

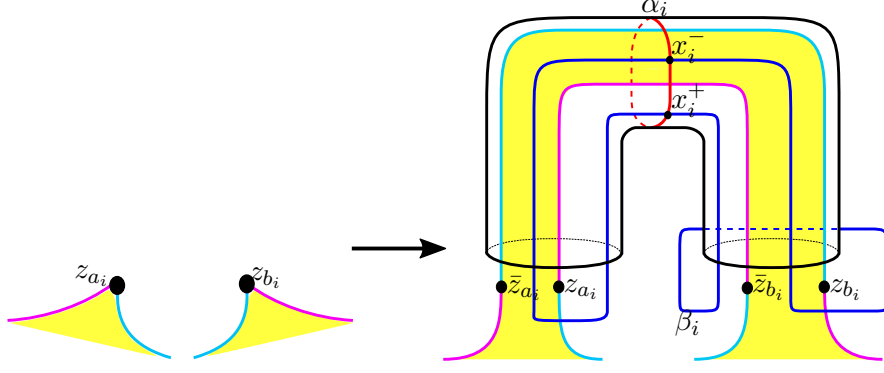

FIGURE 5. The i -th one-handle is attached over the marked points z_{a_i} and z_{b_i} . The curves α_i and β_i , their intersection points x_i^+ and x_i^- and the modification changing P^{i-1} to P^i are illustrated.

Thus, for $i = n$, θ^+ is the only intersection point that does not intersect P^n . As a result, θ^+ is the only intersection point for which $\underline{\mathfrak{s}}(\theta^+) = \underline{\mathfrak{s}}_{F'}$ and thus θ^+ is the generator of

$$\mathrm{SFH}(X_F, \tau_F^b, \underline{\mathfrak{s}}_{F'}) = \mathbb{F}.$$

For every $\epsilon : \{1, \dots, n\} \rightarrow \{+, -\}$, there is a positive disk

$$\phi \in \pi_2(\theta^+, \mathbf{x}^\epsilon) \quad \text{with} \quad \mu(\phi) = \#\{i \mid \epsilon(i) = -\}.$$

Furthermore, $\underline{\mathfrak{s}}(\mathbf{u}_F^b(\phi) \cdot \mathbf{x}^\epsilon) = \underline{\mathfrak{s}}_{F'}$ and if for a monomial $\mathbf{u} \in \mathbb{A}_F^b$ we have $\underline{\mathfrak{s}}(\mathbf{u} \cdot \mathbf{x}^\epsilon) = \underline{\mathfrak{s}}_{F'}$ then $\mathbf{u} = \mathbf{u}_F^b(\phi) \cdot \tilde{\mathbf{u}}$ for some $\tilde{\mathbf{u}} \in \mathbb{A}_F^b$. Hence $\Theta_F^b = \theta^+$, which is closed by our earlier considerations, generates the top-dimensional homology group in

$$\mathrm{HF}(M_F, T_F^b, \mathbf{u}_F^b, \underline{\mathfrak{s}}_{F'})$$

with respect to the relative grading defined above. The above observations complete the proof of the proposition. \square

The algebra \mathbb{A} has a natural \mathbb{A}_F^b -module structure given by the homomorphism $\phi : \mathbb{A}_F^b \rightarrow \mathbb{A}$ defined as

$$\begin{cases} \phi(\mathbf{u}_i) = \mathbf{u}_F(F_i) & 1 \leq i \leq m \\ \phi(\mathbf{v}_i) = 1 & 1 \leq i \leq \kappa. \end{cases}$$

Further, considering this module structure on \mathbb{A} it is straightforward that

$$\mathrm{HF}^{\mathbb{A}}(\mathcal{T}^b) = \mathrm{HF}(\mathcal{T}_F).$$

Definition 6.3. The image of the homolog class $\Theta_F^b \otimes 1$ under the homomorphism

$$\mathrm{HF}(\mathcal{T}^b) \otimes_{\phi} \mathbb{A} \rightarrow \mathrm{H}_*(\mathrm{CF}(\mathcal{T}^b) \otimes_{\phi} \mathbb{A}) = \mathrm{HF}^{\mathbb{A}}(\mathcal{T}^b) = \mathrm{HF}(\mathcal{T}_F)$$

is denoted by Θ_F and is called the *distinguished generator* of $\mathrm{HF}(\mathcal{T}_F)$.

6.3. Framed arcs, framed knots and the cobordism map. Let (M, T) be a balanced tangle, $\mathbb{I} = \{\mathbb{I}_1, \dots, \mathbb{I}_n\}$ be an acceptable set of framed arcs in (M, T) and $\mathbb{S} = \{\mathbb{S}_1, \dots, \mathbb{S}_m\}$ be a set of framed circles in $M \setminus (\mathbb{I} \cup T)$. In other words, each \mathbb{S}_i is determined by a framing on a knot K_i and each \mathbb{I}_i is determined by a framing on an arc I_i . Let $L = \prod_{i=1}^m K_i$ and $I = \prod_{i=1}^n I_i$. As discussed in Section 4.1, (\mathbb{I}, \mathbb{S}) specifies a cobordism $\mathcal{W} = (W, F) = \mathcal{W}(\mathbb{I}, \mathbb{S})$ from (M, T) to $(M', T') = (M(\mathbb{S}), T(\mathbb{I}))$. Here, $T(\mathbb{I})$ is constructed from band surgery on T along \mathbb{I} and $M(\mathbb{S})$ is constructed from M by surgery along the framed link \mathbb{S} .

Definition 6.4. With the above notation fixed, a *stalk* $s(\mathbb{S}) = \{s_1, \dots, s_m\}$ for the framed link \mathbb{S} (disjoint from \mathbb{I}) in (M, T) is a set of embedded arcs in $M \setminus (T \cup \mathbb{I})$ such that s_i connects K_i to $\partial^+ M \setminus T$.

For every i , if \mathbb{I} intersects T_i , let $r_i \subset T_i$ be the segment where

$$\partial^+ r_i \subset \partial^+ M, \quad \partial^- r_i \subset T_i \cap \mathbb{I} \quad \text{and} \quad (T_i - r_i) \cap \mathbb{I} = \emptyset.$$

If $T_i \cap \mathbb{I} = \emptyset$, let $r_i = \emptyset$ and denote $r(\mathbb{I}) = \coprod_{i=1}^k r_i$. Let

$$B(\mathbb{I}) = I \cup r(\mathbb{I}) \quad \text{and} \quad B(\mathbb{S}) = L \cup s(\mathbb{S}).$$

Consider small tubular neighborhoods $\text{nd}(r(\mathbb{I}))$ and $\text{nd}(s(\mathbb{S}))$ of $r(\mathbb{I})$ and $s(\mathbb{S})$, respectively and let

$$N = \mathbb{I} \cup \mathbb{S} \cup \text{nd}(r(\mathbb{I})) \cup \text{nd}(s(\mathbb{S}))$$

be the resulting neighborhood of $B = B(\mathbb{I}) \cup B(\mathbb{S})$. For each $i = 1, \dots, n$, let $A_i \subset \partial N$ be a sphere with 4 boundary components resulted from the intersection of an enlarged neighborhood of I_i with ∂N . Such neighborhoods are illustrated in Figure 6. The intersection of T with $M'' = M - N$ defines a new tangle $(M'', T'' = T \cap M'')$.

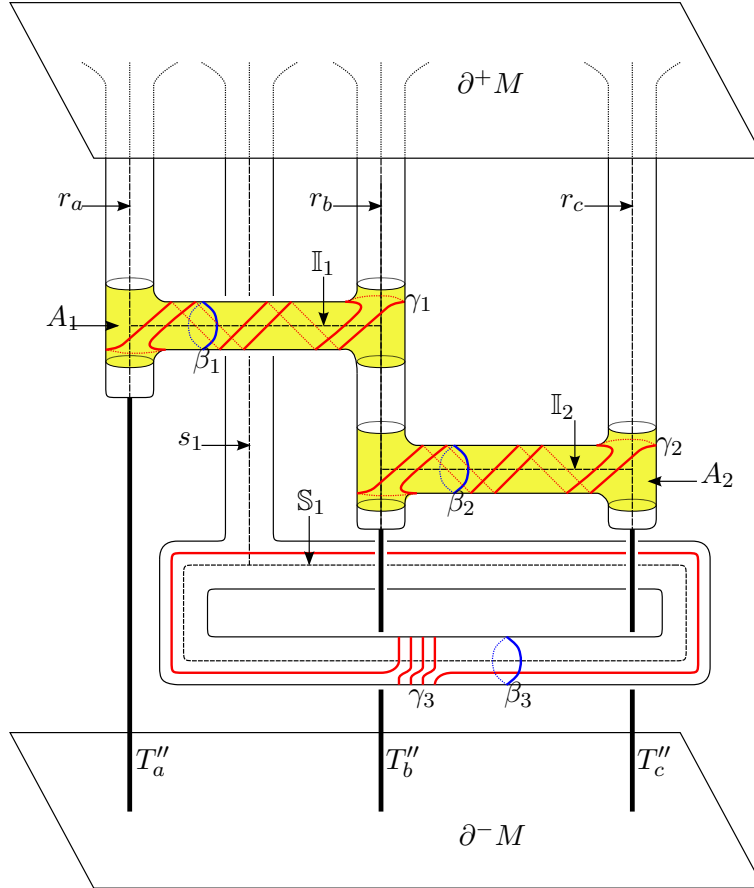

FIGURE 6. A Heegaard diagram subordinate to a framed knot \mathbb{S}_1 and a pair of framed arcs \mathbb{I}_1 and \mathbb{I}_2 with one end point on the same strand T_b of T , and the other ends on the strands T_a and T_c . A tubular neighborhood of the union of $K_1, s_1, I_1, I_2, r_a, r_b$ and r_c is deleted to obtain the tangle (M'', T'') . Attaching disks to the meridians β_1 and β_2 of \mathbb{I}_1 and \mathbb{I}_2 and the meridian β_3 of \mathbb{S}_1 gives a Heegaard diagram for (M, T) while the framings of $\mathbb{I}_1, \mathbb{I}_2$ and \mathbb{S}_1 determine the curves γ_1, γ_2 and γ_3 . The curves γ_1 and γ_2 live in the 4-punctured spheres A_1 and A_2 , respectively.

Definition 6.5. A Heegaard triple *subordinate* to the framed arcs \mathbb{I} , the framed link \mathbb{S} , and the stalk $s(\mathbb{S})$ for the balanced tangle (M, T) is a Heegaard triple

$$(\Sigma, \alpha = \{\alpha_1, \dots, \alpha_\ell\}, \beta = \{\beta_1, \dots, \beta_\ell\}, \gamma = \{\gamma_1, \dots, \gamma_\ell\}, \mathbf{z})$$

satisfying the following conditions:

- (1) $(\Sigma, \alpha, \{\beta_{n+m+1}, \dots, \beta_\ell\}, \mathbf{z})$ is a Heegaard diagram for (M'', T'') . Fix an identification of $\Sigma[\beta_{n+m+1}, \dots, \beta_\ell]$ with $\partial^+ M''$.
- (2) For $i = m + n + 1, \dots, \ell$, γ_i is obtained by a small Hamiltonian isotopy from β_i supported away from the marked points, so that $|\beta_i \cap \gamma_i| = 2$.
- (3) For any $i = 1, \dots, m$, the curves β_{n+i} and γ_{n+i} lie on the punctured torus $\partial \mathbb{S}_i \cap \partial^+ M''$, representing the meridian and the framing of K_i , respectively. Further, they meet in a single transverse intersection point.
- (4) For any $j = 1, \dots, n$, the curves β_j and γ_j lie on the punctured sphere A_j . Moreover, β_j represents the meridian of \mathbb{I}_j and meets γ_j in two transverse intersection points, while γ_j is obtained from β_j by an isotopy corresponding to the framing of \mathbb{I}_j (which crosses two of the boundary components of A_j), as illustrated in Figure 6.
- (5) The Heegaard diagrams $(\Sigma, \alpha, \beta, \mathbf{z})$ and $(\Sigma, \alpha, \gamma, \mathbf{z})$ are diagrams for (M, T) and (M', T') , respectively.

We say that a Heegaard triple is *subordinate* to the framed arcs \mathbb{I} and the framed link \mathbb{S} if it is subordinate to the framed arcs \mathbb{I} and the framed link \mathbb{S} and some stack $s(\mathbb{S})$ for \mathbb{S} .

The existence of Heegaard triples subordinate to an acceptable set of framed arcs \mathbb{I} and a framed link \mathbb{S} for a stable cobordism \mathcal{W} as above and the correspondence between different such Heegaard triples is addressed in the following lemma.

Lemma 6.6. *Let $\mathbb{I} = \{\mathbb{I}_1, \dots, \mathbb{I}_n\}$ be an acceptable set of framed arcs in (M, T) and $\mathbb{S} = \{\mathbb{S}_1, \dots, \mathbb{S}_m\}$ be a framed link in $M \setminus (T \cup \mathbb{I})$. There is a Heegaard triple subordinate to \mathbb{I} and \mathbb{S} . Further, every two such triples may be connected (after composing with a diffeomorphism of the diagram) by a sequence of following moves, all supported away from the set \mathbf{z} of marked points:*

- (1) *Isotopies and handle slides among $\{\alpha_1, \dots, \alpha_\ell\}$,*
- (2) *Isotopies and handle slides among $\{\beta_{n+m+1}, \dots, \beta_\ell\}$ while carrying the corresponding isotopy or handle slide among $\{\gamma_{n+m+1}, \dots, \gamma_\ell\}$,*
- (3) *Stabilization (and destabilization); i.e. taking the connected sum of the Heegaard triple with a triple $(E, \alpha, \beta, \gamma)$, where E is a surface of genus one, $|\alpha \cap \beta| = 1$, and γ is obtained by a small Hamiltonian isotopy from β such that $|\beta \cap \gamma| = 2$,*
- (4) *Isotopies or handle slides of β_{n+j} along the curves in $\{\beta_{n+m+1}, \dots, \beta_\ell\}$ for $j = 1, \dots, m$,*
- (5) *Isotopy or handle slides of γ_{n+j} along the curves in $\{\gamma_{n+m+1}, \dots, \gamma_\ell\}$ for $j = 1, \dots, m$,*
- (6) *For $i = 1, \dots, n$, isotopy or handle slide of β_i along the curves $\{\beta_{n+m+1}, \dots, \beta_\ell\}$, while carrying the corresponding isotopy or handle slide on γ_i ,*
- (7) *Handle slide of a curve in $\{\beta_{n+m+1}, \dots, \beta_\ell\}$ along some β_{n+j} for $j = 1, \dots, m$, while doing a handle slide of the corresponding curve in $\{\gamma_{n+m+1}, \dots, \gamma_\ell\}$ along γ_{n+j} .*

Proof. Given the stack $s(\mathbb{S})$ for \mathbb{S} , the proof of Lemma 4.5 from [OS06] may be used to show that Heegaard diagrams subordinate to \mathbb{I} , \mathbb{S} and $s(\mathbb{S})$ exist and that for every pair H and H' of such diagrams, H may be changed to H' via a sequence of moves of types 1, 2, 3, 4, 5 and 6 in the statement of the lemma. If the stacks $s(\mathbb{S})$ and $s'(\mathbb{S})$ are different, the proof of [OS06, Lemma 4.8] implies that there is a Heegaard diagram H as above subordinate to \mathbb{I} , \mathbb{S} and $s(\mathbb{S})$ and a Heegaard diagram H' subordinate to \mathbb{I} , \mathbb{S} and the stalk $s'(\mathbb{S})$ such that the following is true. There is a sequence of handle slides of some particular curves in $\{\beta_{n+m+1}, \dots, \beta_\ell\}$ over the curves β_{n+j} for $j = 1, \dots, m$ and other curves in $\{\beta_{n+m+1}, \dots, \beta_\ell\}$ (and a corresponding sequence of handle slides for γ) which change H to H' . The lemma then follows. \square

Let $H = (\Sigma, \boldsymbol{\alpha}, \boldsymbol{\beta}, \boldsymbol{\gamma}, \mathbf{z})$ be a Heegaard triple subordinated to the framed arcs \mathbb{I} and the framed link \mathbb{S} as above. Associated with H we have a cobordism

$$\mathcal{W}_H = (W_H, F_H) : (M, T) \amalg (M_{\beta\gamma}, T_{\beta\gamma}) \rightsquigarrow (M(\mathbb{S}), T(\mathbb{I})),$$

where $(M_{\beta\gamma}, T_{\beta\gamma})$ is the balanced tangle determined by the Heegaard diagram $(\Sigma, \boldsymbol{\beta}, \boldsymbol{\gamma}, \mathbf{z})$. This cobordism is related to $\mathcal{W}(\mathbb{I}, \mathbb{S}) = (W, F)$ as follows.

Each \mathbb{I}_i determines an embedded arc J_i on F with endpoints on T . After applying a smooth isotopy supported in a neighborhood of ∂F on $J = \{J_1, \dots, J_n\}$ which moves the endpoints to $\partial^+ F$, it becomes a spanning set of arcs on F . Let $\text{nd}(J)$ be a tubular neighborhood of J . Then,

$$(W - \text{nd}(J), F \cap (W - \text{nd}(J)))$$

gives a cobordism from $(M, T) \amalg (M_F, T_F)$ to $(M(\mathbb{S}), T(\mathbb{I}))$.

Lemma 6.7. *Under the above assumptions, after attaching 3-handles along $S_1, \dots, S_{\ell-n-m} \subset M_{\beta\gamma}$ to \mathcal{W}_H , we obtain the cobordism*

$$(W - \text{nd}(J), F \cap (W - \text{nd}(J))).$$

Proof. Denote the compression body obtained by attaching disks to $\Sigma \times [0, 1]$ along $\boldsymbol{\beta} \times \{1\}$ by $C(\boldsymbol{\beta})$. Without loss of generality, we may assume that

$$\mathbb{I}_i, \mathbb{S}_j \subset C(\boldsymbol{\beta}) \quad \text{for } i \in \{1, \dots, n\}, j \in \{1, \dots, m\}.$$

Furthermore, we may consider an identification

$$W = (M \times [0, 1]) \cup_{\{1\} \times \mathbb{S}} \left(\bigcup_{i=1}^m D^2 \times D^2 \right)$$

such that $\pi_2|_F$ is a Morse function with all critical points of index one. Here, π_2 is the projection map from $M \times [0, 1] \setminus \{1\} \times \mathbb{S}$ onto $[0, 1]$. Moreover, we assume that

$$\text{Crit}(\pi_2|_F) \subset M \times \{1/2\}.$$

Thus, $T_{1/2} = F \cap (M \times \{1/2\})$ is a properly embedded, oriented, singular 1-dimensional submanifold of $M \times \{1/2\}$. For every framed arc \mathbb{I}_i we have a singular point

$$q_i \in T_{1/2} \cap (C(\boldsymbol{\beta}) \times \{1/2\}) \subset F.$$

Let $B'(\mathbb{I}) \subset T_{1/2}$ be the subspace corresponding to $B(\mathbb{I})$. Let $N', N_{1/2} \subset W$ be tubular neighborhoods of $B'(\mathbb{I})$ and $C(\boldsymbol{\beta}) \times \{1/2\}$, respectively. Then

$$\begin{aligned} (W - N', F \cap (W - N')) &= (W - \text{nd}(J), F \cap (W - \text{nd}(J))) \quad \text{and} \\ (W - N_{1/2}, F \cap (W - N_{1/2})) &= \mathcal{W}_H. \end{aligned}$$

Thus, $(W - \text{nd}(J), F \cap (W - \text{nd}(J)))$ is obtained from \mathcal{W}_H by attaching 3-handles along the spheres $S_1, \dots, S_{\ell-n-m} \subset M_{\beta\gamma}$. \square

It follows from the proof of Lemma 6.7 that (M_F, T_F) is obtained by surgery on $(M_{\beta\gamma}, T_{\beta\gamma})$ along the 2-spheres $S_1, \dots, S_{\ell-m-n}$. Abusing the notation, let $\mathfrak{s}_0 \in \text{Spin}^c(M_{\beta\gamma})$ denote the Spin^c class obtained from $\mathfrak{s}_0 \in \text{Spin}^c(M_F)$ which satisfies

$$\langle c_1(\mathfrak{s}_0), S_i \rangle = 0 \quad \text{for any } i \in \{1, 2, \dots, \ell - n - m\}.$$

For any Heegaard tripe H subordinated to \mathbb{I} and \mathbb{S} , let

$$r : \text{Spin}^c(\mathcal{W}(\mathbb{I}, \mathbb{S})) \rightarrow \text{Spin}^c(\mathcal{W}_H).$$

denote the restriction map.

Lemma 6.8. *For every $\mathfrak{t} \in \text{Spin}^c(\mathcal{W}(\mathbb{I}, \mathbb{S}))$, the restriction $r(\mathfrak{t})|_{M_{\beta\gamma}}$ is the Spin^c class $\mathfrak{s}_0 \in \text{Spin}^c(M_{\beta\gamma})$.*

Proof. This is straightforward. \square

Suppose $\mathbf{u}_F : \pi_0(F) \rightarrow \mathbb{A}$ be an \mathbb{A} -coloring for $\mathcal{W}(\mathbb{I}, \mathbb{S})$. Given a Spin^c class $\mathfrak{t} \in \text{Spin}^c(\mathcal{W}(\mathbb{I}, \mathbb{S}))$ we abuse the notation and call the Heegaard triple $(\Sigma, \boldsymbol{\alpha}, \boldsymbol{\beta}, \boldsymbol{\gamma}, \mathbf{u})$ \mathfrak{t} -admissible, if it is $r(\mathfrak{t})$ -admissible. Here $\mathbf{u} : \mathbf{z} \rightarrow \mathbb{A}$ denotes the map induced by \mathbf{u}_F . Note that every diagram $(\Sigma, \boldsymbol{\alpha}, \boldsymbol{\beta}, \boldsymbol{\gamma}, \mathbf{u})$ subordinate to \mathbb{I} and \mathbb{S} may be transformed to a \mathfrak{t} -admissible Heegaard diagram by performing isotopies on the curves in $\boldsymbol{\alpha}$, following a procedure similar to [AE15, Section 4.2]. Let us assume that the Heegaard diagram $(\Sigma, \boldsymbol{\alpha}, \boldsymbol{\beta}, \boldsymbol{\gamma}, \mathbf{u})$ subordinate to \mathbb{I} and \mathbb{S} is \mathfrak{t} -admissible. We then call $\mathcal{H} = (\Sigma, \boldsymbol{\alpha}, \boldsymbol{\beta}, \boldsymbol{\gamma}, \mathbf{u}, \mathfrak{t})$ an \mathbb{A} -diagram for

$$\mathcal{C} = \mathcal{C}(\mathbb{I}, \mathbb{S}) = [W, F, \mathfrak{t}, \mathbf{u}_F] : \mathcal{T} = [M, T, \mathfrak{s} = \mathfrak{t}|_{M, \mathbf{u}_T}] \rightsquigarrow \mathcal{T}' = [M', T', \mathfrak{s}' = \mathfrak{t}|_{M', \mathbf{u}'_T}],$$

subordinate to \mathbb{I} and \mathbb{S} . Here, \mathbf{u}_T and \mathbf{u}'_T are the \mathbb{A} -colorings induced by \mathbf{u}_F on (M, T) and (M', T') , respectively.

For an appropriate generic family of almost complex structures J , the \mathbb{A} -diagram \mathcal{H} determines a holomorphic triangle map

$$\mathfrak{f}_{\alpha\beta\gamma} : \text{HF}_J(\Sigma, \boldsymbol{\alpha}, \boldsymbol{\beta}, \mathbf{u}, \mathfrak{s}) \otimes_{\mathbb{A}} \text{HF}_J(\Sigma, \boldsymbol{\beta}, \boldsymbol{\gamma}, \mathbf{u}, \mathfrak{s}_0) \longrightarrow \text{HF}_J(\Sigma, \boldsymbol{\alpha}, \boldsymbol{\gamma}, \mathbf{u}, \mathfrak{s}').$$

From the Heegaard diagram $(\Sigma, \boldsymbol{\beta}, \boldsymbol{\gamma}, \mathbf{z})$ for $(M_{\beta\gamma}, T_{\beta\gamma})$ we may construct a Heegaard diagram $H' = (\Sigma', \boldsymbol{\beta}', \boldsymbol{\gamma}', \mathbf{z})$ for (M_F, T_F) where Σ' is obtained by surgery on Σ along $\beta_{n+m+1}, \dots, \beta_\ell$, while

$$\boldsymbol{\beta}' = \{\beta_1, \dots, \beta_{n+m}\} \quad \text{and} \quad \boldsymbol{\gamma}' = \{\gamma_1, \dots, \gamma_{n+m}\}.$$

Following the construction in Section 5.3, we get a homomorphism

$$\mathfrak{f}_{\beta\gamma} : \text{HF}(\Sigma', \boldsymbol{\beta}', \boldsymbol{\gamma}', \mathbf{u}, \mathfrak{s}_0) \rightarrow \text{HF}(\Sigma, \boldsymbol{\beta}, \boldsymbol{\gamma}, \mathbf{u}, \mathfrak{s}_0).$$

Then, we set $\Theta_{\beta\gamma} := \mathfrak{f}_{\beta\gamma}(\Theta_F)$ and define

$$\begin{aligned} \mathfrak{f}_{\mathcal{H}, J} &: \text{HF}_J(\Sigma, \boldsymbol{\alpha}, \boldsymbol{\beta}, \mathbf{u}, \mathfrak{s}) \longrightarrow \text{HF}_J(\Sigma, \boldsymbol{\alpha}, \boldsymbol{\gamma}, \mathbf{u}, \mathfrak{s}') \\ \mathfrak{f}_{\mathcal{H}, J}(\mathbf{x}) &:= \mathfrak{f}_{\alpha\beta\gamma}(\mathbf{x} \otimes \Theta_{\beta\gamma}) \quad \text{for any } \mathbf{x} \in \text{HF}_J(\Sigma, \boldsymbol{\alpha}, \boldsymbol{\beta}, \mathbf{u}, \mathfrak{s}). \end{aligned}$$

Theorem 6.9. *For any \mathbb{A} -module \mathbb{M} , the homomorphism $\mathfrak{f}_{\mathcal{H}, J}$ induces a homomorphism*

$$\mathfrak{f}_{\mathcal{C}, \mathbb{I}, \mathbb{S}}^{\mathbb{M}} : \text{HF}^{\mathbb{M}}(\mathcal{T}) \rightarrow \text{HF}^{\mathbb{M}}(\mathcal{T}').$$

6.4. Proof of Theorem 6.9. It follows from standard arguments in Floer theory that for appropriate families of almost complex structures J and J' , we have

$$\mathfrak{f}_{\mathcal{H}, J'} \circ \Phi_{J \rightarrow J'} = \Phi_{J \rightarrow J'} \circ \mathfrak{f}_{\mathcal{H}, J}.$$

So we denote the induced map by $\mathfrak{f}_{\mathcal{H}}$. Let

$$\mathcal{H} = (\Sigma, \boldsymbol{\alpha}, \boldsymbol{\beta}, \boldsymbol{\gamma}, \mathbf{u}, \mathfrak{t}) \quad \text{and} \quad \mathcal{H}' = (\Sigma', \boldsymbol{\alpha}', \boldsymbol{\beta}', \boldsymbol{\gamma}', \mathbf{u}', \mathfrak{t})$$

be \mathbb{A} -diagrams for \mathcal{C} subordinate to \mathbb{I} and \mathbb{S} . Assume that \mathcal{H}' is obtained from \mathcal{H} by one Heegaard move e of the type specified in Lemma 6.6. Associated with e , let

$$\begin{aligned} \Phi_e &: \text{HF}^{\mathbb{M}}(\Sigma, \boldsymbol{\alpha}, \boldsymbol{\beta}, \mathbf{u}, \mathfrak{s}) \rightarrow \text{HF}^{\mathbb{M}}(\Sigma', \boldsymbol{\alpha}', \boldsymbol{\beta}', \mathbf{u}', \mathfrak{s}), \\ \Psi_e &: \text{HF}^{\mathbb{M}}(\Sigma, \boldsymbol{\alpha}, \boldsymbol{\gamma}, \mathbf{u}, \mathfrak{s}') \rightarrow \text{HF}^{\mathbb{M}}(\Sigma', \boldsymbol{\alpha}', \boldsymbol{\gamma}', \mathbf{u}', \mathfrak{s}'). \end{aligned}$$

be the isomorphisms defined in Section 3.3. We need to prove that the diagram

$$\begin{array}{ccc} \text{HF}^{\mathbb{M}}(\Sigma, \boldsymbol{\alpha}, \boldsymbol{\beta}, \mathbf{u}, \mathfrak{s}) & \xrightarrow{\mathfrak{f}_{\mathcal{H}}} & \text{HF}^{\mathbb{M}}(\Sigma, \boldsymbol{\alpha}, \boldsymbol{\gamma}, \mathbf{u}, \mathfrak{s}') \\ \Phi_e \downarrow & & \downarrow \Psi_e \\ \text{HF}^{\mathbb{M}}(\Sigma', \boldsymbol{\alpha}', \boldsymbol{\beta}', \mathbf{u}', \mathfrak{s}) & \xrightarrow{\mathfrak{f}_{\mathcal{H}'}} & \text{HF}^{\mathbb{M}}(\Sigma', \boldsymbol{\alpha}', \boldsymbol{\gamma}', \mathbf{u}', \mathfrak{s}') \end{array}$$

commutes. Let us first consider the Heegaard move e which changes $\boldsymbol{\alpha}$ to $\boldsymbol{\alpha}'$ and keeps $\Sigma, \boldsymbol{\beta}, \boldsymbol{\gamma}$ and \mathbf{z} unchanged. The 4-manifold $W_{\alpha\beta\gamma}$ is obtained by attaching 3-handles to $W_{\alpha'\alpha\beta\gamma}$. Abusing the notation, denote the restriction of \mathfrak{t} to $W_{\alpha'\alpha\beta\gamma}$ by \mathfrak{t} . Let \mathfrak{S}_e be the homomorphism associated with the \mathbb{A} -diagram $(\Sigma, \boldsymbol{\alpha}', \boldsymbol{\alpha}, \boldsymbol{\beta}, \boldsymbol{\gamma}, \mathbf{u}, \mathfrak{t})$ and the distinguished generators $\Theta_{\alpha'\alpha}$ and $\Theta_{\beta\gamma}$, defined by

counting holomorphic squares. Considering different possible degenerations of a square either to a bigon and a square or to a pair of triangles gives the relation

$$\Psi_e \circ \mathfrak{f}_{\mathcal{H}} - \mathfrak{f}_{\mathcal{H}'} \circ \Phi_e = \mathfrak{S}_e \circ d + d \circ \mathfrak{S}_e,$$

following the standard arguments in Heegaard Floer theory. With a similar argument, if e is a Heegaard move that changes β to β' (respectively γ to γ') and keeps Σ , α , γ (respectively β) and \mathbf{z} fixed, the diagram commutes.

Suppose e changes both β and γ simultaneously to β' and γ' . We obtain a pair of maps $\mathfrak{S}_i = \mathfrak{S}_{e,i}$, $i = 1, 2$ which correspond to the Heegaard quadruples

$$(\Sigma, \alpha, \beta, \beta', \gamma', \mathbf{u}, \mathbf{t}) \text{ and } (\Sigma, \alpha, \beta, \gamma, \gamma', \mathbf{u}, \mathbf{t}),$$

respectively. Denote the holomorphic triangle maps corresponding to the Heegaard subdiagrams

$$(\Sigma, \alpha, \beta, \gamma', \mathbf{u}, \mathbf{t}), (\Sigma, \beta, \gamma, \gamma', \mathbf{u}, \mathbf{t}) \text{ and } (\Sigma, \beta, \beta', \gamma', \mathbf{u}, \mathbf{t})$$

by $\mathfrak{f}_{\alpha\beta\gamma'}$, $\mathfrak{f}_{\beta\gamma\gamma'}$ and $\mathfrak{f}_{\beta\beta'\gamma'}$, respectively.

The images of the distinguished generator $\Theta_{\beta\gamma} \otimes \Theta_{\gamma\gamma'}$ under $\mathfrak{f}_{\beta\gamma\gamma'}$ and the distinguished generator $\Theta_{\beta\beta'} \otimes \Theta_{\beta'\gamma'}$ under $\mathfrak{f}_{\beta\beta'\gamma'}$ is the distinguished generator $\Theta_{\beta\gamma'}$ which corresponds to $(\Sigma, \beta, \gamma', \mathbf{u}, \mathbf{t})$. This should be done independently for each one of the Heegaard moves. The proofs follow from the standard arguments in Heegaard Floer theory since the Heegaard triples $(\Sigma, \beta, \gamma, \gamma', \mathbf{z})$ and $(\Sigma, \beta, \beta', \gamma')$ have standard forms.

Let us abuse the notation and denote $\mathfrak{f}_{\alpha\beta\gamma'}(- \otimes \Theta_{\beta\gamma'})$ by $\mathfrak{f}_{\alpha\beta\gamma'}$. Setting $\mathfrak{S}_e = \mathfrak{S}_1 + \mathfrak{S}_2$, the study of different possible degenerations of a square to a bigon and a square or to two triangles gives

$$\begin{aligned} \mathfrak{f}_{\alpha\beta\gamma'} - \mathfrak{f}_{\mathcal{H}'} \circ \Phi_e &= \mathfrak{S}_1 \circ d + d \circ \mathfrak{S}_1 \text{ and} \\ \Psi_e \circ \mathfrak{f}_{\mathcal{H}} - \mathfrak{f}_{\alpha\beta\gamma'} &= \mathfrak{S}_2 \circ d + d \circ \mathfrak{S}_2 \\ \Rightarrow \Psi_e \circ \mathfrak{f}_{\mathcal{H}} - \mathfrak{f}_{\mathcal{H}'} \circ \Phi_e &= \mathfrak{S}_e \circ d + d \circ \mathfrak{S}_e. \end{aligned}$$

Note that the map \mathfrak{S}_e is trivial when e is a stabilization or destabilization, provided that the complex structure is sufficiently stretched along the neck.

7. THE COBORDISM MAP AND ITS INVARIANCE

Let $\mathcal{C} = [W, F, \mathfrak{t}, \mathfrak{u}_F]$ be a stable \mathbb{A} -cobordism from $\mathcal{T} = [M, T, \mathfrak{s}, \mathfrak{u}]$ to $\mathcal{T}' = [M', T', \mathfrak{s}', \mathfrak{u}']$. Consider an indexed parametrized decomposition

$$\tilde{\mathcal{C}} : \mathcal{W} = \mathcal{W}_1 \cup_{(M_1, T_1)} \mathcal{W}_2 \cup_{(M_2, T_2)} \mathcal{W}_3.$$

Recall that for $i = 1, 3$, the cobordism \mathcal{W}_i is parametrized by a set $\mathbb{S}_i \subset M_{i-1} \setminus T_{i-1}$ of pairwise disjoint framed $(i-1)$ -spheres, and a diffeomorphism

$$d_i : (M_{i-1}(\mathbb{S}_i), T_{i-1}) \rightarrow (M_i, T_i).$$

Further, \mathcal{W}_2 is parametrized by a framed link \mathbb{S}_2 and a set of pairwise disjoint framed arcs \mathbb{I} in (M_1, T_1) along with a diffeomorphism

$$d_2 : (M_1(\mathbb{S}_2), T_1(\mathbb{I})) \rightarrow (M_2, T_2).$$

For each $\mathcal{W}_i = (W_i, F_i)$, let \mathfrak{t}_i and \mathfrak{u}_i be the Spin^c structure and the \mathbb{A} -coloring induced by \mathfrak{t} and \mathfrak{u}_F , respectively. Note that \mathfrak{t} determines \mathfrak{t}_i for $i = 1, 2, 3$, while \mathfrak{t}_2 determines \mathfrak{t} . Let $\mathcal{C}_i = [W_i, F_i, \mathfrak{s}_i, \mathfrak{u}_i]$. In addition, \mathfrak{t} and \mathfrak{u}_F induce an Spin^c structure on (M_i, T_i) , denoted by \mathfrak{s}_i , and an \mathbb{A} -coloring denoted by \mathfrak{u}_i , abusing the notation. For $0 \leq i \leq 3$, let $\mathcal{T}_i = [M_i, T_i, \mathfrak{s}_i, \mathfrak{u}_i]$, where $\mathcal{T}_0 = \mathcal{T}$, and $\mathcal{T}_3 = \mathcal{T}'$.

For every \mathbb{A} -module \mathbb{M} , the constructions of Section 5 and Section 6 associate naturally defined \mathbb{A} -homomorphisms

$$\mathfrak{f}_i = \text{HF}^{\mathbb{M}}(d_i) \circ \mathfrak{f}_{\mathbb{S}_i}^{\mathbb{M}} : \text{HF}^{\mathbb{M}}(\mathcal{T}_{i-1}) \longrightarrow \text{HF}^{\mathbb{M}}(\mathcal{T}_i)$$

to the parametrized \mathbb{A} -cobordism \mathcal{C}_i for $i = 1, 3$ and

$$\mathfrak{f}_2 = \text{HF}^{\mathbb{M}}(d_2) \circ \mathfrak{f}_{\mathcal{C}_2, \mathbb{I}, \mathbb{S}_2}^{\mathbb{M}} : \text{HF}^{\mathbb{M}}(\mathcal{T}_1) \longrightarrow \text{HF}^{\mathbb{M}}(\mathcal{T}_2)$$

to the parametrized \mathbb{A} -cobordism \mathcal{C}_2 . Subsequently, we may define

$$(5) \quad \mathfrak{f}_{\mathcal{C}, \tilde{\mathcal{C}}}^{\mathbb{M}} : \text{HF}^{\mathbb{M}}(\mathcal{T}) \longrightarrow \text{HF}^{\mathbb{M}}(\mathcal{T}'), \quad \mathfrak{f}_{\mathcal{C}, \tilde{\mathcal{C}}}^{\mathbb{M}} = \mathfrak{f}_3 \circ \mathfrak{f}_2 \circ \mathfrak{f}_1.$$

The homomorphism $\mathfrak{f}_{\mathcal{C}, \tilde{\mathcal{C}}}^{\mathbb{M}}$ is well-defined and natural, while *a priori* it depends on the indexed parametrized decomposition $\tilde{\mathcal{C}}$.

Theorem 7.1. *Let \mathcal{C} be an \mathbb{A} -cobordism from the \mathbb{A} -tangle \mathcal{T} to the \mathbb{A} -tangle \mathcal{T}' . For every \mathbb{A} -module \mathbb{M} , the \mathbb{A} -homomorphism*

$$\mathfrak{f}_{\mathcal{C}, \tilde{\mathcal{C}}}^{\mathbb{M}} : \text{HF}^{\mathbb{M}}(\mathcal{T}) \rightarrow \text{HF}^{\mathbb{M}}(\mathcal{T}')$$

is an invariant of \mathcal{C} . More precisely, this \mathbb{A} -homomorphism does not depend on the choice of the indexed parametrized decomposition $\tilde{\mathcal{C}}$ for \mathcal{W} , which was used in its definition.

Proof. With the above notation fixed, Theorem 4.12 reduces the proof to showing the invariance of the homomorphism $\mathfrak{f}_{\mathcal{C}, \tilde{\mathcal{C}}}^{\mathbb{M}}$ under the following changes:

- (1) Sliding a component of \mathbb{S}_i on another component of \mathbb{S}_i for $i = 1, 2, 3$,
- (2) Sliding a component of \mathbb{I} on another component of \mathbb{I} or a component of \mathbb{S}_2 ,
- (3) Sliding a component of \mathbb{S}_2 on a component of \mathbb{I} ,
- (4) Creation and cancellation of index one/two or two/three critical points,
- (5) Diffeomorphism equivalences.

Invariance under the move (1) follows from the arguments in [OS06, Subsection 4.4], and invariance under the moves (4) and (5) is straightforward. We will prove invariance under the moves (2) and (3) in Sections 7.1 and 7.2. \square

7.1. Invariance under arc slides. Let $\mathcal{C} = [W, F, \mathfrak{t}, \mathbf{u}_F]$ be an \mathbb{A} -cobordism defined by an acceptable set of framed arcs \mathbb{I} and a framed link \mathbb{S} in an \mathbb{A} -tangle $\mathcal{T} = [M, T, \mathfrak{s}, \mathbf{u}]$. Thus, the \mathbb{A} -cobordism \mathcal{C} is from \mathcal{T} to $\mathcal{T}' = [M(\mathbb{S}), T(\mathbb{I}), \mathfrak{s}', \mathbf{u}']$ where $\mathfrak{s}' = \mathfrak{t}|_{M(\mathbb{S})}$ and \mathbf{u}' is the \mathbb{A} -coloring induced by \mathbf{u}_F on $(M(\mathbb{S}), T(\mathbb{I}))$. Suppose $\tilde{\mathbb{I}}$ is an acceptable set of framed arcs obtained from \mathbb{I} by arc slides. Corresponding to $(\tilde{\mathbb{I}}, \mathbb{S})$ we get a diffeomorphism

$$D : (W, F) \rightarrow (\tilde{W}, \tilde{F})$$

where (\tilde{W}, \tilde{F}) is the cobordism from (M, T) to $(M(\mathbb{S}), T(\tilde{\mathbb{I}}))$ defined by $(\tilde{\mathbb{I}}, \mathbb{S})$. Note that $d^0 = D|_{(M, T)}$ is isotopic to identity and let $d = D|_{(M(\mathbb{S}), T(\mathbb{I}))}$. So, $(\mathbb{I}, \mathbb{S}, d)$ and $(\tilde{\mathbb{I}}, \mathbb{S}, \text{id})$ are two parameterizations of (\tilde{W}, \tilde{F}) . The Spin^c structure \mathfrak{t} and the \mathbb{A} -coloring \mathbf{u}_F induce a Spin^c structure and an \mathbb{A} -coloring on (\tilde{W}, \tilde{F}) , denoted by $\tilde{\mathbf{u}}_F$ and $\tilde{\mathfrak{t}}$. Set $\tilde{\mathcal{C}} = [\tilde{W}, \tilde{F}, \tilde{\mathfrak{t}}, \tilde{\mathbf{u}}_F]$ and let $\mathcal{T}'' = [M(\mathbb{S}), T(\tilde{\mathbb{I}}), \mathfrak{s}'', \mathbf{u}'']$ where \mathfrak{s}'' and \mathbf{u}'' are induced by $\tilde{\mathbf{u}}_F$ and $\tilde{\mathfrak{t}}$, respectively. Thus, d is a diffeomorphism between the \mathbb{A} -tangles \mathcal{T}' and \mathcal{T}'' .

Theorem 7.2. *With the above notation fixed, for any \mathbb{A} -module \mathbb{M}*

$$\text{HF}^{\mathbb{M}}(d) \circ \mathfrak{f}_{\mathcal{C}, \mathbb{I}, \mathbb{S}}^{\mathbb{M}} = \mathfrak{f}_{\tilde{\mathcal{C}}, \tilde{\mathbb{I}}, \mathbb{S}}^{\mathbb{M}} : \text{HF}^{\mathbb{M}}(\mathcal{T}) \longrightarrow \text{HF}^{\mathbb{M}}(\mathcal{T}'').$$

Proof. Assume $\tilde{\mathbb{I}}$ is obtained from \mathbb{I} by a single arc slide of \mathbb{I}_1 over \mathbb{I}_2 . Let

$$\mathcal{H} = (\Sigma, \boldsymbol{\alpha} = \{\alpha_1, \dots, \alpha_\ell\}, \boldsymbol{\beta} = \{\beta_1, \dots, \beta_\ell\}, \boldsymbol{\gamma} = \{\gamma_1, \dots, \gamma_\ell\}, \mathbf{u} : \mathbf{z} \rightarrow \mathbb{A}, \mathfrak{t})$$

be an \mathbb{A} -diagram subordinate to \mathbb{I} and \mathbb{S} , as in Definition 6.5. Then, we obtain an \mathbb{A} -diagram subordinate to $\tilde{\mathbb{I}}$ and \mathbb{S} by handle sliding β_2 over β_1 and γ_1 over γ_2 as in Figure 7. Here, β_i and γ_i are the closed curves corresponding to \mathbb{I}_i for $i = 1, 2$. Let

$$\tilde{\mathcal{H}} = (\Sigma, \boldsymbol{\alpha}, \tilde{\boldsymbol{\beta}}, \tilde{\boldsymbol{\gamma}}, \mathbf{u} : \mathbf{z} \rightarrow \mathbb{A}, \tilde{\mathfrak{t}})$$

be the resulting Heegaard triple. Following an argument analogous to the proof of Theorem 6.9, we show that the diagram

$$\begin{array}{ccc} \text{HF}^{\mathbb{M}}(\Sigma, \boldsymbol{\alpha}, \boldsymbol{\beta}, \mathbf{u}, \mathfrak{s}) & \xrightarrow{\mathfrak{f}_{\mathcal{H}}^{\mathbb{M}}} & \text{HF}^{\mathbb{M}}(\Sigma, \boldsymbol{\alpha}, \boldsymbol{\gamma}, \mathbf{u}, \mathfrak{s}') \\ \Phi \downarrow & & \Phi' \downarrow \\ \text{HF}^{\mathbb{M}}(\Sigma, \boldsymbol{\alpha}, \tilde{\boldsymbol{\beta}}, \mathbf{u}, \mathfrak{s}) & \xrightarrow{\mathfrak{f}_{\tilde{\mathcal{H}}}^{\mathbb{M}}} & \text{HF}^{\mathbb{M}}(\Sigma, \boldsymbol{\alpha}, \tilde{\boldsymbol{\gamma}}, \mathbf{u}, \mathfrak{s}'') \end{array}$$

commutes. Here, Φ and Φ' are isomorphisms corresponding to the aforementioned handle slides.

On the other hand, let $h : \Sigma \rightarrow \Sigma$ be the diffeomorphism, which maps β_2 to β_1 , γ_1 to γ_2 and preserves the rest of β and γ curves. Then, h induces the diffeomorphism D from (W, F) to (\tilde{W}, \tilde{F}) as well as the diffeomorphism d , and

$$\tilde{\mathcal{H}}' = (\Sigma, h(\boldsymbol{\alpha}), \tilde{\boldsymbol{\beta}}, \tilde{\boldsymbol{\gamma}}, \mathbf{u} : \mathbf{z} \rightarrow \mathbb{A}, \tilde{\mathfrak{t}})$$

is the corresponding Heegaard triple subordinate to $(\tilde{\mathbb{I}}, \mathbb{S})$ for (\tilde{W}, \tilde{F}) . Note that $\tilde{\mathcal{H}}'$ is obtained from $\tilde{\mathcal{H}}$ by a sequence e of isotopy and handle slide on α curves i.e. moves of type (1) in Lemma 6.6. Theorem 6.9 implies that $\Psi_e \circ \mathfrak{f}_{\tilde{\mathcal{H}}} = \mathfrak{f}_{\tilde{\mathcal{H}}'} \circ \Phi_e$, where

$$\Phi_e : \text{HF}^{\mathbb{M}}(\Sigma, \boldsymbol{\alpha}, \tilde{\boldsymbol{\beta}}, \mathbf{u}, \mathfrak{s}) \rightarrow \text{HF}^{\mathbb{M}}(\Sigma, h(\boldsymbol{\alpha}), \tilde{\boldsymbol{\beta}}, \mathbf{u}, \mathfrak{s}) \quad \text{and}$$

$$\Psi_e : \text{HF}^{\mathbb{M}}(\Sigma, \boldsymbol{\alpha}, \tilde{\boldsymbol{\gamma}}, \mathbf{u}, \mathfrak{s}') \rightarrow \text{HF}^{\mathbb{M}}(\Sigma, h(\boldsymbol{\alpha}), \tilde{\boldsymbol{\gamma}}, \mathbf{u}, \mathfrak{s}'')$$

are the isomorphisms associated with the Heegaard moves e . Since d is induced by h , it follows that,

$$d_* \circ \mathfrak{f}_{\mathcal{H}}^{\mathbb{M}} = \Psi_e \circ \Phi' \circ \mathfrak{f}_{\tilde{\mathcal{H}}}^{\mathbb{M}} = \mathfrak{f}_{\tilde{\mathcal{H}}'}^{\mathbb{M}} \circ \Phi_e \circ \Phi = \mathfrak{f}_{\tilde{\mathcal{H}}'}^{\mathbb{M}} \circ d_*^0.$$

Therefore, $\text{HF}^{\mathbb{M}}(d) \circ \mathfrak{f}_{\mathcal{C}, \mathbb{I}, \mathbb{S}}^{\mathbb{M}} = \mathfrak{f}_{\tilde{\mathcal{C}}, \tilde{\mathbb{I}}, \mathbb{S}}^{\mathbb{M}}$. □

We may thus restrict our attention to ordered sets of framed arcs. This is particularly useful when we study the composition law in the following subsections.

7.2. A composition law for framed arcs and links. Let $\mathcal{C} = [W, F, \mathfrak{t}, \mathfrak{u}_F]$ be an \mathbb{A} -cobordism from the \mathbb{A} -tangle $\mathcal{T} = [M, T, \mathfrak{s}, \mathfrak{u}]$ to the \mathbb{A} -tangle $\mathcal{T}' = [M', T', \mathfrak{s}', \mathfrak{u}']$. Further, assume that (W, F) is the cobordism corresponding to an acceptable set of framed arcs \mathbb{I} , and a framed link \mathbb{S} . Given a decomposition $\mathbb{S} = \mathbb{S}^1 \amalg \mathbb{S}^2$ and $\mathbb{I} = \mathbb{I}^1 \amalg \mathbb{I}^2$ where \mathbb{I}^1 is acceptable, we obtain a decomposition

$$(W, F) = (W_1, F_1) \cup_{(M'', T'')} (W_2, F_2).$$

Here, (W_1, F_1) is the cobordism associated with $(\mathbb{I}^1, \mathbb{S}^1)$ and (W_2, F_2) is the cobordism associated with $(\mathbb{I}^2, \mathbb{S}^2)$ in $(M'', T'') = (M(\mathbb{S}^1), T(\mathbb{I}^1))$. For $i = 1, 2$, let \mathfrak{u}_i denote the \mathbb{A} -coloring induced by \mathfrak{u}_F on (W_i, F_i) , and $\mathfrak{t}_i = \mathfrak{t}|_{W_i}$. Consider the corresponding \mathbb{A} -cobordisms

$$\mathcal{C}^1 = [W_1, F_1, \mathfrak{t}_1, \mathfrak{u}_1] : \mathcal{T} \rightsquigarrow \mathcal{T}'' \quad \text{and} \quad \mathcal{C}^2 = [W_2, F_2, \mathfrak{t}_2, \mathfrak{u}_2] : \mathcal{T}'' \rightsquigarrow \mathcal{T}',$$

where \mathcal{T}'' denotes the \mathbb{A} -tangle obtained by equipping (M'', T'') with the induced \mathbb{A} -coloring and Spin^c structure from \mathfrak{u}_F and \mathfrak{t} , respectively.

The restrictions of \mathfrak{t} to W_1 and W_2 remain unchanged, under modifying \mathfrak{t} by adding an element of $\delta H^1(M'', \mathbb{Z})$, where $\delta : H^1(M'', \mathbb{Z}) \rightarrow H^2(W, \mathbb{Z})$ is the connecting homomorphism in the Mayer-Vietoris sequence for (W_1, W_2) . So, let \mathfrak{X} be the set of all Spin^c classes on W so that their restrictions to W_1 and W_2 are equal to \mathfrak{t}_1 and \mathfrak{t}_2 , respectively.

Theorem 7.3. *With the above notation fixed, for every \mathbb{A} -module \mathbb{M} we have*

$$f_{\mathcal{C}^2, \mathbb{I}^2, \mathbb{S}^2}^{\mathbb{M}} \circ f_{\mathcal{C}^1, \mathbb{I}^1, \mathbb{S}^1}^{\mathbb{M}} = \sum_{\bar{\mathfrak{t}} \in \mathfrak{X}} f_{\mathcal{C}(\bar{\mathfrak{t}}), \mathbb{I}, \mathbb{S}}^{\mathbb{M}},$$

where $\mathcal{C}(\bar{\mathfrak{t}})$ is the \mathbb{A} -cobordism obtained from \mathcal{C} by replacing \mathfrak{t} with $\bar{\mathfrak{t}}$.

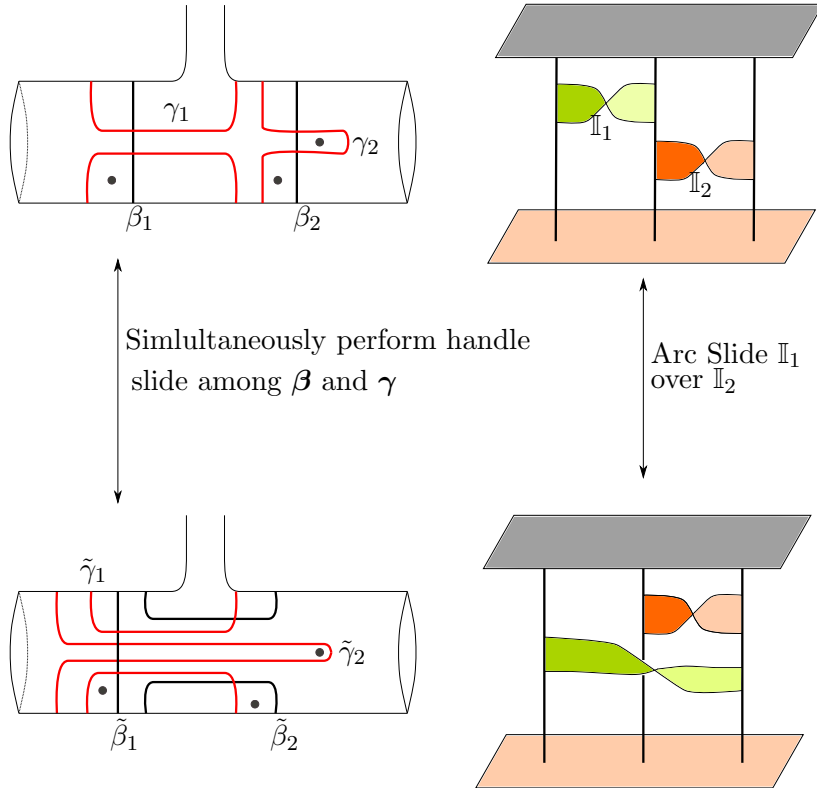

FIGURE 7. Sliding a framed arc \mathbb{I}_1 over another framed arc \mathbb{I}_2 .

Proof. Any acceptable set of framed arcs can be turned into an ordered set by arc slides. So Theorem 7.2 implies that without loss of generality, we may assume \mathbb{I} is ordered such that

$$\mathbb{I}^1 = (\mathbb{I}_1, \dots, \mathbb{I}_{n_1}) \quad \text{and} \quad \mathbb{I}^2 = (\mathbb{I}_{n_1+1}, \dots, \mathbb{I}_{n_1+n_2}), \quad \text{where } n_1 + n_2 = n.$$

Furthermore, suppose that

$$\mathbb{S}^1 = (\mathbb{S}_1, \dots, \mathbb{S}_{m_1}) \quad \text{and} \quad \mathbb{S}^2 = (\mathbb{S}_{m_1+1}, \dots, \mathbb{S}_{m_1+m_2}).$$

Let us fix an \mathbb{A} -diagram $\mathcal{H} = (\Sigma, \alpha, \beta, \gamma, \mathbf{u}, \mathbf{t})$ subordinate to (\mathbb{I}, \mathbb{S}) . Let $\delta = \{\delta_1, \dots, \delta_\ell\}$ denote a set of curves obtained as follows:

- Let δ_i be a Hamiltonian isotope of γ_i for every i in

$$A = \{1, \dots, n_1\} \cup \{n+1, \dots, n+m_1\}.$$

- For every $i \in \{1, \dots, \ell\} - A$, let δ_i be a Hamiltonian isotope of β_i .

The Spin^c structures \mathbf{t}_1 and \mathbf{t}_2 induce Spin^c structures on $W_{\alpha\beta\delta}$ and $W_{\alpha\delta\gamma}$, which will also be denoted by \mathbf{t}_1 and \mathbf{t}_2 , by slight abuse of notation. Then the \mathbb{A} -diagrams

$$\mathcal{H}_1 = (\Sigma, \alpha, \beta, \delta, \mathbf{u}, \mathbf{t}_1) \quad \text{and} \quad \mathcal{H}_2 = (\Sigma, \alpha, \delta, \gamma, \mathbf{u}, \mathbf{t}_2)$$

are subordinate to $(\mathbb{I}^1, \mathbb{S}^1)$ and $(\mathbb{I}^2, \mathbb{S}^2)$ and correspond to \mathcal{C}_1 and \mathcal{C}_2 , respectively. These two Heegaard triples determine the maps $\mathbf{f}_1 = \mathbf{f}_{\mathcal{C}_1, \mathbb{I}^1, \mathbb{S}^1}$ and $\mathbf{f}_2 = \mathbf{f}_{\mathcal{C}_2, \mathbb{I}^2, \mathbb{S}^2}$. Furthermore, the \mathbb{A} -diagram

$$(\Sigma, \alpha, \beta, \delta, \gamma, \mathbf{u}, \mathfrak{T})$$

and the distinguished generators

$$\Theta_{\beta\delta} \in \text{HF}(\Sigma, \beta, \delta, \mathbf{u}, \mathbf{t}_1 |_{M_{\beta\delta}} = \mathfrak{s}_0) \quad \text{and} \quad \Theta_{\delta\gamma} \in \text{HF}(\Sigma, \delta, \gamma, \mathbf{u}, \mathbf{t}_2 |_{M_{\delta\gamma}} = \mathfrak{s}_0)$$

determine a holomorphic square map

$$\mathfrak{S} : \text{HF}(\Sigma, \alpha, \beta, \mathbf{u}, \mathfrak{s}) = \text{HF}(\mathcal{T}) \longrightarrow \text{HF}(\Sigma, \alpha, \gamma, \mathbf{u}, \mathfrak{s}') = \text{HF}(\mathcal{T}').$$

Considering different degenerations of a square class of index 0 and applying a mild generalization of [OS04c, Theorem 8.16], we obtain the relation

$$\mathbf{f}_2 \circ \mathbf{f}_1 - \sum_{\bar{\mathbf{i}} \in \mathfrak{T}} \mathbf{f}_{\alpha\beta\gamma, \bar{\mathbf{i}}}(- \otimes \mathbf{f}_{\beta\delta\gamma}(\Theta_{\beta\delta} \otimes \Theta_{\delta\gamma})) = \mathfrak{S} \circ d + d \circ \mathfrak{S}.$$

Here $\mathbf{f}_{\alpha\beta\gamma, \bar{\mathbf{i}}}$ and $\mathbf{f}_{\beta\delta\gamma}$ are the holomorphic triangle maps associated with the Heegaard triples

$$(\Sigma, \alpha, \beta, \gamma, \mathbf{u}, \bar{\mathbf{t}}) \quad \text{and} \quad (\Sigma, \beta, \delta, \gamma, \mathbf{u}, \mathbf{t}_0),$$

respectively, and \mathbf{t}_0 denotes a canonically determined Spin^c structure on the 4-manifold $W_{\beta\delta\gamma}$. In order to complete the proof, it thus suffices to show that

$$\mathbf{f}_{\beta\delta\gamma}(\Theta_{\beta\delta} \otimes \Theta_{\delta\gamma}) = \Theta_{\beta\gamma}.$$

Since $(\Sigma, \alpha, \beta, \gamma, \mathbf{z})$ is a Heegaard triple subordinate to (\mathbb{I}, \mathbb{S}) , the proof of Proposition 6.5 implies the existence of a labeling for the intersection points of β_i and γ_i by d_i^+ and d_i^- , for $i \in \{1, \dots, \ell\} \setminus \{n+1, \dots, n+m\}$, such that $\Theta_{\beta\gamma}$ is represented by

$$\theta_{\beta\gamma}^+ = \{d_1^+, \dots, d_\ell^+\}.$$

Here, d_i^+ denotes the only intersection point of β_i and γ_i for $n+1 \leq i \leq n+m$. Similarly, it follows from the definition of δ that we may label the intersection points of δ with β and γ such that $\Theta_{\beta\delta}$ and $\Theta_{\delta\gamma}$ are respectively represented by:

$$\theta_{\beta\delta}^+ = \{c_1^+, \dots, c_\ell^+\} \quad \text{and} \quad \theta_{\delta\gamma}^+ = \{b_1^+, \dots, b_\ell^+\}.$$

Let us now assume that $\theta \in \mathbb{T}_\beta \cap \mathbb{T}_\gamma$ contributes to $\mathbf{f}_{\beta\delta\gamma}(\Theta_{\beta\delta} \otimes \Theta_{\delta\gamma})$ through a triangle class

$$\Delta = \Delta^\ell \in \pi_2 \left(\theta_{\beta\delta}^+, \theta_{\delta\gamma}^+, \theta \right)$$

of Maslov index 0. For any $1 \leq i \leq \ell$, consider the Heegaard triple

$$H^i = (\Sigma^i = \Sigma[\beta_{i+1}, \dots, \beta_\ell], \beta^i = \{\beta_1, \dots, \beta_i\}, \delta^i = \{\delta_1, \dots, \delta_i\}, \gamma^i = \{\gamma_1, \dots, \gamma_i\}, \mathbf{z})$$

where $\Sigma[\beta_{i+1}, \dots, \beta_\ell]$ denotes the surface obtained from Σ by performing surgery along the β -curves $\{\beta_{i+1}, \beta_{i+2}, \dots, \beta_\ell\}$. Therefore, Σ^ℓ is obtained from $\Sigma^{\ell-1}$ by attaching a 1-handle, and corresponding to Δ^ℓ , when the necks are sufficiently stretched, we obtain a triangles class $\Delta^{\ell-1}$ on $\Sigma^{\ell-1}$ and a class Δ' on the attached one-handle which connects

$$c_\ell^+ \in \beta_\ell \cap \delta_\ell, \quad b_\ell^+ \in \delta_\ell \cap \gamma_\ell \quad \text{and} \quad d_\ell^* \in \beta_\ell \cap \gamma_\ell,$$

where \star is either $+$ or $-$. It also follows that

$$\mu(\Delta^\ell) = \mu(\Delta^{\ell-1}) - \epsilon(d_\ell^*),$$

where $\epsilon(d_\ell^+) = 0$ and $\epsilon(d_\ell^-) = 1$. We are thus forced to have $\star = +$. It also follows from the argument of Proposition 5.1 and the second part of Lemma 5.3 that, if the necks are sufficiently stretched, $\mathcal{M}(\Delta^\ell)$ may be identified with $\mathcal{M}(\Delta^{\ell-1})$. This argument may in fact be repeated again and again to show that the generator θ uses the intersection points

$$d_i^+ \in \beta_i \cap \gamma_i, \quad \text{for } i = n + m + 1, \dots, \ell,$$

and that $\mathcal{M}(\Delta^\ell)$ may be identified with $\mathcal{M}(\Delta^{n+m})$, for a triangle class over Σ^{n+m} .

Now $\Sigma^{n+m} = \Sigma^{n+m-1} \# E$ where E is a surface of genus 1. If we stretch the connected sum neck, the complex structure on Σ^{n+m} converges to the join of complex structures on the $\Sigma^{n+m-1} - \{w\}$ and $E - \{w'\}$. We also obtain a decomposition of Δ^{n+m} to the triangle classes Δ^{n+m-1} (on Σ^{n+m-1}) and Δ' (on E). The generator θ is forced to use the unique intersection point $d_{n+m} \in \beta_{n+m} \cap \gamma_{n+m}$. From the choice of the intersection points in $\theta_{\beta\delta}^+$ and $\theta_{\delta\gamma}^+$ it also follows that $\mu(\Delta^{n+m-1}) = \mu(\Delta^{n+m}) = 0$. Furthermore, as the weak limit of a sequence of holomorphic curves in $\mathcal{M}(\Delta^{n+m})$ as the neck is stretched, we obtain a degenerate holomorphic curve u^{n+m-1} in the 0-dimensional moduli space $\mathcal{M}(\Delta^{n+m-1})$, which has coefficient k at w . The holomorphic curve u^{n+m-1} determines a point $\rho(u^{n+m-1})$ in $\text{Sym}^k(\mathbb{D})$. Let Δ_k denote the union of all triangle classes Δ' over the genus-one surface E with coefficient k over the marked point w' . The arguments of Section 12 of [Lip06], and in particular Lemma 12.2, Proposition 12.4 (in fact, Proposition A.3), imply that in the aforementioned weak limit, u^{n+m-1} is paired with a degenerate curve v on E , which is the union of

$$E \times \rho(u^{n+m-1}) \subset E \times \mathbb{D}$$

and the unique holomorphic representative of Δ_0 , to produce the only possible curve in the weak limit. Every such weak limit may be perturbed to a holomorphic curve representing Δ^{n+m} , giving an identification of $\mathcal{M}(\Delta^{n+m})$ with $\mathcal{M}(\Delta^{n+m-1})$, if the connected sum neck is sufficiently long. Again, we may repeat the above argument to find an identification of $\mathcal{M}(\Delta^\ell)$ with $\mathcal{M}(\Delta^n)$, provided that attaching the 1-handles and taking connected sum with surfaces of genus 1 is done using sufficiently stretched necks.

The surface Σ^n is obtained from Σ^{n-1} by attaching a 1-handle and moving two of the markings (which we denote by $z, z' \in \mathbf{z}$) over the attached 1-handle. The curves β_n, δ_n and γ_n are all isotopic to the belt circle of the attached 1-handle, while the positions of z and z' in the cylinder representing the neck is the position illustrated on the right-hand-side of Figure 8. Correspondingly, when the necks are sufficiently stretched, we obtain a triangles class Δ^{n-1} on Σ^{n-1} and a class Δ' on the attached one-handle which connects the intersection points

$$c_n^+ \in \beta_n \cap \delta_n, \quad b_n^+ \in \delta_n \cap \gamma_n \quad \text{and} \quad d_n^* \in \beta_n \cap \gamma_n,$$

where \star is either $+$ or $-$. It also follows that

$$\mu(\Delta^n) = \mu(\Delta^{n-1}) - \epsilon(d_n^*),$$

where $\epsilon(d_n^+) = 0$ and $\epsilon(d_n^-) = 1$. We are thus forced to have $d_n = d_n^+$. It also follows from the argument of Proposition 5.1 and the second part of Lemma 5.3 that, if the necks are sufficiently stretched, $\mathcal{M}(\Delta^n)$ may be identified with $\mathcal{M}(\Delta^{n-1})$. This argument may be repeated to show that the generator θ uses the intersection points

$$d_i^+ \in \beta_i \cap \gamma_i, \quad \text{for } i = 1, \dots, n,$$

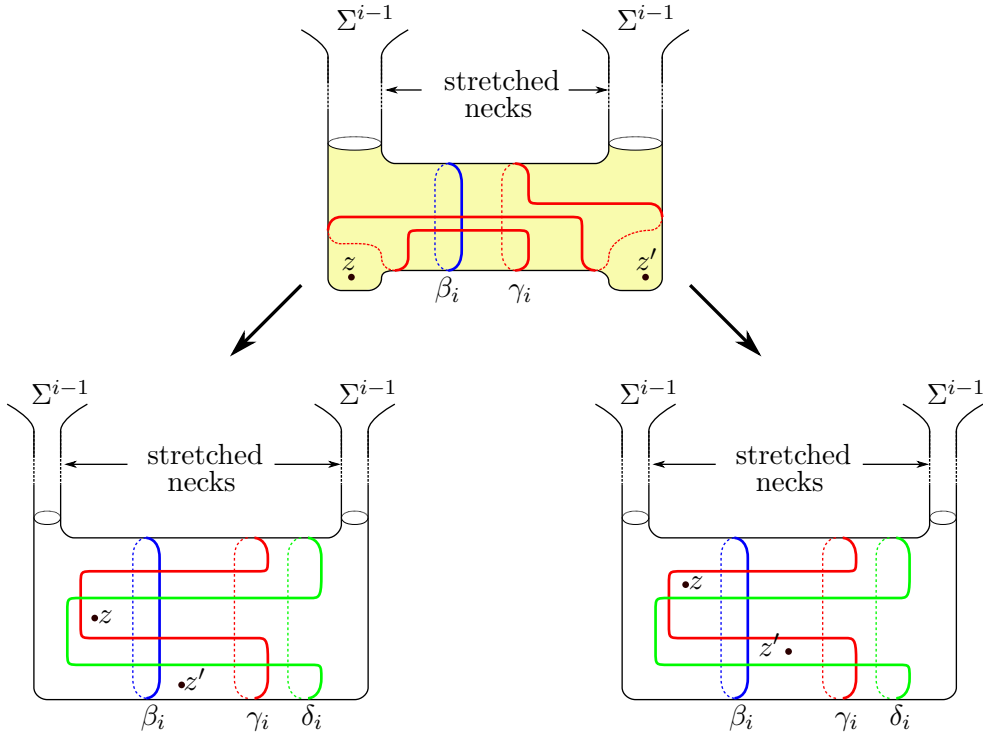

FIGURE 8. As we stretch the neck, Σ^i degenerates to a subsurface Σ^{i-1} and a sphere, which are attached by two long necks. When $i \in \{1, \dots, n_1\}$ a pair of markings $z, z' \in \mathbf{z}$ will land on the sphere as illustrated on the left-hand-side, while for $i \in \{n_1 + 1, \dots, n\}$ their location follows the pattern illustrated on the right-hand-side.

and that $\mathcal{M}(\Delta^\ell)$ may be identified with $\mathcal{M}(\Delta^1)$, which consists of a single point.

The above argument shows that θ is forced to represent the generator $\Theta_{\beta\gamma}$, and that the total contribution of holomorphic triangles to the coefficient of θ in $\mathfrak{f}_{\beta\gamma\delta}(\Theta_{\beta\delta} \otimes \Theta_{\delta\gamma})$ is 1. This completes the proof of the theorem. \square

Corollary 7.4. *Assume $\mathcal{C} = [W, F, \mathfrak{t}, \mathbf{u}_F]$ is an \mathbb{A} -cobordism from \mathcal{T} to \mathcal{T}' , determined by an acceptable set of framed arcs \mathbb{I} and a framed link \mathbb{S} i.e. $(\mathbb{I}, \mathbb{S}, \text{id})$ gives a parametrization of (W, F) . Let \mathbb{I}' be an acceptable set of framed arcs obtained from \mathbb{I} by sliding some of its components over some components of \mathbb{S} , and similarly \mathbb{S}' be the framed link obtained from \mathbb{S} by sliding some of its components over some of the framed arcs in \mathbb{I} . Denote the induced diffeomorphisms by*

$$d_{\mathbb{I}} : \mathcal{T}(\mathbb{I}', \mathbb{S}) \rightarrow \mathcal{T}' \quad \text{and} \quad d_{\mathbb{S}} : \mathcal{T}(\mathbb{I}, \mathbb{S}') \rightarrow \mathcal{T}'.$$

Then for any \mathbb{A} -module \mathbb{M} we have

$$\mathfrak{f}_{\mathcal{C}, \mathbb{I}, \mathbb{S}}^{\mathbb{M}} = \text{HF}^{\mathbb{M}}(d_{\mathbb{I}}) \circ \mathfrak{f}_{\mathcal{C}, \mathbb{I}', \mathbb{S}}^{\mathbb{M}} \quad \text{and} \quad \mathfrak{f}_{\mathcal{C}, \mathbb{I}, \mathbb{S}}^{\mathbb{M}} = \text{HF}^{\mathbb{M}}(d_{\mathbb{S}}) \circ \mathfrak{f}_{\mathcal{C}, \mathbb{I}, \mathbb{S}'}^{\mathbb{M}}.$$

Proof. Note that $(\mathbb{I}', \mathbb{S}, d_{\mathbb{I}})$ and $(\mathbb{I}, \mathbb{S}', d_{\mathbb{S}})$ are parametrizations of \mathcal{C} , or (W, F) . The claim is then a straightforward result of Theorems 7.2 and 7.3 \square

This completes the proof of Theorem 7.1, and we may now denote the \mathbb{A} -homomorphism associated with the \mathbb{A} -cobordism \mathcal{C} and the \mathbb{A} -module \mathbb{M} by $\mathfrak{f}_{\mathcal{C}}^{\mathbb{M}}$.

7.3. The composition law. In this subsection, we prove a generalization of Theorem 7.3.

Theorem 7.5. *Suppose that $\mathcal{C}_i = [W_i, F_i, \mathfrak{t}_i, \mathbf{u}_i] : \mathcal{T}_{i-1} \rightarrow \mathcal{T}_i$ are \mathbb{A} -cobordisms for $i = 1, \dots, m$. Let $\mathcal{W} = (W, F)$ be the stable cobordism obtained by putting $\mathcal{W}_i = (W_i, F_i)$ together and $\mathbf{u} : \pi_0(F) \rightarrow \mathbb{A}$*

denote the \mathbb{A} -coloring induced by \mathbf{u}_i . For every $\mathfrak{t} \in \text{Spin}^c(W)$ with $\mathfrak{t}|_{W_i} = \mathfrak{t}_i$, let $\mathcal{C}(\mathfrak{t}) = [W, F, \mathfrak{t}, \mathbf{u}]$. Then

$$(6) \quad \sum_{\substack{\mathfrak{t} \in \text{Spin}^c(W) \\ \mathfrak{t}|_{W_i} = \mathfrak{t}_i}} \mathfrak{f}_{\mathcal{C}(\mathfrak{t})}^{\mathbb{M}} = \mathfrak{f}_{\mathcal{C}_m}^{\mathbb{M}} \circ \cdots \circ \mathfrak{f}_{\mathcal{C}_1}^{\mathbb{M}}.$$

Proof. The definition of the cobordism invariants and Theorem 7.3 reduce the proof of Theorem 7.5 to the case where $m = 2$, both \mathcal{C}_1 and \mathcal{C}_2 are parametrized elementary \mathbb{A} -cobordisms, and one of the following happens.

- (1) \mathcal{W}_1 corresponds to a framed 2-sphere \mathbb{S}_1 , and \mathcal{W}_2 corresponds to a framed 0-sphere \mathbb{S}_2 .
- (2) \mathcal{W}_1 corresponds to a framed 2-sphere \mathbb{S}_1 , and \mathcal{W}_2 corresponds to a framed knot \mathbb{S}_2 .
- (3) \mathcal{W}_1 corresponds to a framed 2-sphere \mathbb{S} , and \mathcal{W}_2 corresponds to a framed arc \mathbb{I} .
- (4) \mathcal{W}_1 corresponds to a framed knot \mathbb{S}_1 , and \mathcal{W}_2 corresponds to a framed 0-sphere \mathbb{S}_2 .
- (5) \mathcal{W}_1 corresponds to a framed arc \mathbb{I} , and \mathcal{W}_2 corresponds to a framed 0-sphere \mathbb{S} .

For all cases, there is a unique Spin^c class \mathfrak{t} on W such that $\mathfrak{t}|_{W_i} = \mathfrak{t}_i$ for $i = 1, 2$. We may thus set $\mathcal{C} = \mathcal{C}(\mathfrak{t})$. Let $\mathcal{T} = \mathcal{T}_0 = [M, T, \mathfrak{s}, \mathbf{u}]$ and $\mathcal{T}' = \mathcal{T}_2 = [M', T', \mathfrak{s}', \mathbf{u}']$.

In the first case, W_1 is determined by the framed 2-sphere \mathbb{S}_1 , so the underlying tangle of \mathcal{T}_1 is $(M_1, T_1) = (M(\mathbb{S}_1), T)$. Considering this identification, we may assume that \mathbb{S}_2 lies in $M \setminus \mathbb{S}_1 = M \cap M_1$. Thus, \mathbb{S}_2 specifies a cobordism \mathcal{W}_1^r from (M, T) to $(M(\mathbb{S}_2), T)$. Similarly, \mathbb{S}_1 specifies a cobordism \mathcal{W}_2^r from $(M(\mathbb{S}_2), T)$ to (M', T') . As a result we get an indexed parametrized decomposition $\mathcal{W}_1^r \cup_{(M(\mathbb{S}_2), T)} \mathcal{W}_2^r$ for (W, F) .

The \mathbb{A} -coloring \mathbf{u} and the Spin^c class \mathfrak{t} make \mathcal{W}_1^r and \mathcal{W}_2^r into \mathbb{A} -cobordisms, denoted by \mathcal{C}_1^r and \mathcal{C}_2^r , respectively. Let $\mathcal{T}^r = [M(\mathbb{S}_2), T, \mathfrak{s}^r = \mathfrak{t}|_{M(\mathbb{S}_2)}, \mathbf{u}]$. Consider the following diagram:

$$\begin{array}{ccc} \text{HF}^{\mathbb{M}}(\mathcal{T}) & \xrightarrow{\mathfrak{f}_{\mathcal{C}_1}^{\mathbb{M}}} & \text{HF}^{\mathbb{M}}(\mathcal{T}_1) \\ \mathfrak{f}_{\mathcal{C}_1^r}^{\mathbb{M}} \downarrow & & \mathfrak{f}_{\mathcal{C}_2}^{\mathbb{M}} \downarrow \\ \text{HF}^{\mathbb{M}}(\mathcal{T}^r) & \xrightarrow{\mathfrak{f}_{\mathcal{C}_2^r}^{\mathbb{M}}} & \text{HF}^{\mathbb{M}}(\mathcal{T}'). \end{array}$$

Every generator of $\text{CF}^{\mathbb{M}}(\mathcal{T})$ is of the form $\mathbf{x} \times \theta$, where \mathbf{x} is a generator of the chain complex $\text{CF}^{\mathbb{M}}(\mathcal{T}_1)$ and θ is one of the two intersection points $\theta_{\alpha\beta}^1$ and $\theta_{\beta\alpha}^1$ corresponding to the framed 2-sphere \mathbb{S}_1 , (see Section 5.3). If the necks in the corresponding Heegaard diagrams for \mathbb{S}_1 and \mathbb{S}_2 are sufficiently stretched, this generator is mapped to $\mathbf{x} \times \theta \times \theta_{\alpha\beta}^2$ under $\mathfrak{f}_{\mathcal{C}_1}^{\mathbb{M}}$. Here $\theta_{\alpha\beta}^2$ and $\theta_{\beta\alpha}^2$ are the two intersection points which correspond to the 1-handle, attached to \mathbb{S}_2 . The generator $\mathbf{x} \times \theta \times \theta_{\alpha\beta}^2$ goes to zero under $\mathfrak{f}_{\mathcal{C}_2^r}^{\mathbb{M}}$ unless $\theta = \theta_{\beta\alpha}^1$, when it is mapped to $\mathbf{x} \times \theta_{\alpha\beta}^2$. On the other hand, the image of $\mathbf{x} \times \theta$ under $\mathfrak{f}_{\mathcal{C}_1}^{\mathbb{M}}$ is zero unless $\theta = \theta_{\beta\alpha}^1$, when

$$\mathfrak{f}_{\mathcal{C}_1}^{\mathbb{M}}(\mathbf{x} \times \theta_{\beta\alpha}^1) = \mathbf{x} \quad \text{and} \quad \mathfrak{f}_{\mathcal{C}_2}^{\mathbb{M}}\left(\mathfrak{f}_{\mathcal{C}_1}^{\mathbb{M}}(\mathbf{x} \times \theta_{\beta\alpha}^1)\right) = \mathbf{x} \times \theta_{\alpha\beta}^2.$$

This implies that the above diagram is commutative and

$$\mathfrak{f}_{\mathcal{C}_2}^{\mathbb{M}} \circ \mathfrak{f}_{\mathcal{C}_1}^{\mathbb{M}} = \mathfrak{f}_{\mathcal{C}_2^r}^{\mathbb{M}} \circ \mathfrak{f}_{\mathcal{C}_1^r}^{\mathbb{M}} = \mathfrak{f}_{\mathcal{C}}^{\mathbb{M}}.$$

A similar modification to the proofs of [OS06, Proposition 4.19 and Proposition 4.18], imply the theorem in the second and fourth cases, respectively. The only remaining cases are thus the third and the fifth cases.

In the third case, \mathcal{C}_1 corresponds to attaching a 3-handle along \mathbb{S} and \mathcal{C}_2 corresponds to a framed arc \mathbb{I} . This framed arc may clearly be isotoped to $M \setminus \mathbb{S}$. Therefore, we get an indexed parametrized decomposition of (W, F) by switching the order of attached handles. More precisely, let \mathcal{W}_1^r to be the cobordism determined by \mathbb{I} from (M, T) to $(M, T(\mathbb{I}))$ and \mathcal{C}_2^r be the cobordism determined by \mathbb{S} from $(M, T(\mathbb{I}))$ to (M', T') . For $i = 1, 2$, the \mathbb{A} -cobordism obtained by equipping \mathcal{W}_i^r with the

\mathbb{A} -coloring induced by \mathbf{u} and Spin^c structure induced by \mathbf{t} is denoted by \mathcal{C}_i^r . Correspondingly, we may choose a Heegaard surface Σ in M with the following properties:

- The intersection of Σ with \mathbb{S} is an annulus A , such that the surface Σ° in M_1 obtained by cutting off A and gluing in a pair of disks to the two boundary components, is a Heegaard surface for M_1 . Here, M_1 is the underlying 3-manifold of \mathcal{T}_1 .
- Each component of T intersects Σ transversely in exactly one point. We let $\mathbf{z} = T \cap \Sigma$.
- There are two collections $\boldsymbol{\alpha}$ and $\boldsymbol{\beta}$ of attaching circles on Σ such that $\boldsymbol{\alpha} \cap A$ is a single circle α which is a small Hamiltonian isotope of the circle $\{\beta\} = \boldsymbol{\beta} \cap A$. Moreover, the diagram $(\Sigma, \boldsymbol{\alpha}, \boldsymbol{\beta}, \mathbf{u} : \mathbf{z} \rightarrow \mathbb{A}, \mathfrak{s})$ is a Heegaard diagram for \mathcal{T} and

$$(\Sigma^\circ, \boldsymbol{\alpha} \setminus \{\alpha\}, \boldsymbol{\beta} \setminus \{\beta\}, \mathbf{u} : \mathbf{z} \rightarrow \mathbb{A}, \mathfrak{s}_1)$$

is a Heegaard diagram from \mathcal{T}_1 , where $\mathfrak{s}_1 = \mathfrak{t}|_{M_1}$.

- There is a third collection $\boldsymbol{\gamma}$ of pairwise disjoint circles on Σ so that $\boldsymbol{\gamma} \cap A$ is a single circle γ which is a small Hamiltonian isotope of both α and β and

$$(\Sigma^\circ, \boldsymbol{\alpha} \setminus \{\alpha\}, \boldsymbol{\beta} \setminus \{\beta\}, \boldsymbol{\gamma} \setminus \{\gamma\}, \mathbf{z})$$

is subordinate to the framed arc \mathbb{I} in \mathcal{T}_1 . In particular, the diagram $(\Sigma^\circ, \boldsymbol{\alpha} \setminus \{\alpha\}, \boldsymbol{\gamma} \setminus \{\gamma\}, \mathbf{z})$ is a Heegaard diagram for (M', T') .

Note that $(\Sigma, \boldsymbol{\alpha}, \boldsymbol{\beta}, \boldsymbol{\gamma}, \mathbf{z})$ is subordinate to \mathbb{I} , where \mathbb{I} is considered as a framed arc in \mathcal{T} . Consider such a Heegaard diagram and assume that the almost complex structure is sufficiently stretched along the boundary circles of A . Every generator of $\text{CF}^{\mathbb{M}}(\mathcal{T})$ is of the form $\mathbf{x} \times \theta$, where \mathbf{x} is a generator of $\text{CF}^{\mathbb{M}}(\mathcal{T}_1)$ and θ is one of the two intersection points $\theta_{\alpha\beta}$ and $\theta_{\beta\alpha}$ between α and β which correspond to \mathbb{S} . The image of such a generator under $\mathfrak{f}_{\mathcal{C}_1}^{\mathbb{M}}$ is trivial unless $\theta = \theta_{\beta\alpha}$, when we have $\mathfrak{f}_{\mathcal{C}_1}^{\mathbb{M}}(\mathbf{x} \times \theta_{\beta\alpha}) = \mathbf{x}$. On the other hand, we may use the argument of Theorem 7.3 and show that

$$\mathfrak{f}_{\mathcal{C}_1}^{\mathbb{M}}(\mathbf{x} \times \theta) = \mathfrak{f}_{\mathcal{C}_2}^{\mathbb{M}}(\mathbf{x}) \times \theta'$$

where $\theta' \in \alpha \cap \gamma$ is the intersection point which corresponds to θ . Every such generator is mapped to 0 by $\mathfrak{f}_{\mathcal{C}_2}^{\mathbb{M}}$ unless $\theta' = \theta_{\gamma\alpha}$, or equivalently, unless $\theta = \theta_{\beta\alpha}$. If this condition is satisfied, then

$$\mathfrak{f}_{\mathcal{C}_2}^{\mathbb{M}}(\mathfrak{f}_{\mathcal{C}_1}^{\mathbb{M}}(\mathbf{x} \times \theta_{\beta\alpha})) = \mathfrak{f}_{\mathcal{C}_2}^{\mathbb{M}}(\mathbf{x}),$$

which completes the proof of the third case. The proof of the fifth case is similar to the proof of the third case. \square

The composition law of Theorem 7.5 implies, in particular, that the left-hand-side expression is well-defined. Let us define

$$W^0 = \bigcup_{i \equiv 0 \pmod{2}} W_i \quad \text{and} \quad W^1 = \bigcup_{i \equiv 1 \pmod{2}} W_i.$$

Then $W^0 \cup W^1 = W$ and $W^0 \cap W^1 = \bigcup_{i=1}^{m-1} M_i$, where $M_i = M_{\mathcal{T}_i}$, and we obtain the following cohomology long exact sequence

$$\cdots \longrightarrow \bigoplus_{i=1}^{m-1} H^1(M_i, \mathbb{Z}) \xrightarrow{\delta} H^2(W) \xrightarrow{\pi} \bigoplus_{i=1}^m H^2(W_i, \mathbb{Z}) \longrightarrow \cdots$$

If $\mathbf{t}, \mathbf{t}' \in \text{Spin}^c(W)$ restrict to \mathbf{t}_i on W_i , then $\mathbf{t} - \mathbf{t}' \in H^2(W, \mathbb{Z})$ is a class in the kernel of π , and is thus in the image of δ . In particular, the subset $\mathfrak{X} \subset \text{Spin}^c(W)$ which appears in the summation of the left-hand-side of Equation 6 is the orbit of a fixed Spin^c structure \mathbf{t} under the action of the \mathbb{Z} -module $\text{Im}(\delta)$ of $H^2(W, \mathbb{Z})$. On the other hand, using an appropriate Morse datum \mathfrak{M} , we may represent every \mathbb{Z} -submodule of $H^2(W, \mathbb{Z})$ as $\text{Im}(\delta)$ for some decomposition of the stable cobordism (W, F) . In particular, for every affine set \mathfrak{X} of Spin^c structures over a \mathbb{Z} -submodule of $H^2(W, \mathbb{Z})$ which restrict to \mathfrak{s} and \mathfrak{s}' on the two ends, the sum

$$\sum_{\mathbf{t} \in \mathfrak{X}} \mathfrak{f}_{\mathcal{C}_i}^{\mathbb{M}} : \text{HF}^{\mathbb{M}}(\mathcal{T}) \rightarrow \text{HF}^{\mathbb{M}}(\mathcal{T}')$$

is well-defined.

Definition 7.1. Let $\mathcal{C} = [W, F, \mathfrak{T}, \mathbf{u}_F] : \mathcal{T} \rightsquigarrow \mathcal{T}'$ be an arbitrary \mathbb{A} -cobordism from the \mathbb{A} -tangle \mathcal{T} to the \mathbb{A} -tangle \mathcal{T}' , where \mathfrak{T} is a subset of $\text{Spin}^c(W)$ which is affine over a \mathbb{Z} -submodule of $H^2(W, \mathbb{Z})$. For every $\mathfrak{t} \in \mathfrak{T}$ define $\mathcal{C}_{\mathfrak{t}} = [W, F, \mathfrak{t}, \mathbf{u}]$. We then define the cobordism map associated with \mathcal{C} by

$$\mathfrak{f}_{\mathcal{C}}^{\mathbb{M}} := \sum_{\mathfrak{t} \in \mathfrak{T}} \mathfrak{f}_{\mathcal{C}_{\mathfrak{t}}}^{\mathbb{M}}.$$

With the above definition in place, we may then re-state Theorem 7.1 and Theorem 7.3 as the following theorem.

Theorem 7.6. Fix an algebra \mathbb{A} over \mathbb{F} and an \mathbb{A} -module \mathbb{M} . Assigning the \mathbb{A} -module $\text{HF}^{\mathbb{M}}(\mathcal{T})$ to every \mathbb{A} -tangle $\mathcal{T} \in \text{Obj}(\mathbb{A}\text{-Tangles})$ and the \mathbb{A} -homomorphism $\mathfrak{f}_{\mathcal{C}}^{\mathbb{M}} : \text{HF}^{\mathbb{M}}(\mathcal{T}) \rightarrow \text{HF}^{\mathbb{M}}(\mathcal{T}')$ to every \mathbb{A} -cobordism

$$(\mathcal{C} : \mathcal{T} \rightsquigarrow \mathcal{T}') \in \text{Mor}(\mathcal{T}, \mathcal{T}') \in \text{Mor}(\mathbb{A}\text{-Tangles})$$

gives a well-defined functor

$$\text{HF}^{\mathbb{M}} : \mathbb{A}\text{-Tangles} \longrightarrow \mathbb{A}\text{-Modules}.$$

7.4. Action of $\Lambda^*(H_1(W, \mathbb{Z})/\text{Tors})$. Let us assume that $\mathcal{C} = [W, F, \mathfrak{t}, \mathbf{u}_F]$ is an \mathbb{A} -cobordism from $\mathcal{T} = [M, T, \mathfrak{s}, \mathbf{u}]$ to $\mathcal{T}' = [M', T', \mathfrak{s}', \mathbf{u}']$. Consider a decomposition of \mathcal{C} as

$$\mathcal{C} = \mathcal{C}_1 \cup_{\mathcal{T}_1} \mathcal{C}_2 \cup_{\mathcal{T}_2} \mathcal{C}_3$$

where \mathcal{C}_1 corresponds to the addition of 1-handles, \mathcal{C}_2 corresponds to the addition of 2-handles along some framed link and band surgeries along framed arcs, and \mathcal{C}_3 corresponds to the addition of 3-handles. Let (M_i, T_i) be the underlying tangle of \mathcal{T}_i and $\mathcal{C}' = \mathcal{C}_2 = [W', F', \mathfrak{t}', \mathbf{u}_{F'}]$. It is clear that $H_1(W', \mathbb{Z}) = H_1(W, \mathbb{Z})$.

Assume \mathcal{C}' is parametrized by a pair (\mathbb{I}, \mathbb{S}) of an acceptable set of framed arcs \mathbb{I} , and a framed link \mathbb{S} such that $M_2 = M_1(\mathbb{S})$ and $T_2 = T_1(\mathbb{I})$. The homomorphism $\mathfrak{f}_{\mathcal{C}'}^{\mathbb{M}} = \mathfrak{f}_{\mathcal{C}', \mathbb{I}, \mathbb{S}}^{\mathbb{M}}$ is defined using an \mathbb{A} -diagram

$$\mathcal{H} = (\Sigma, \boldsymbol{\alpha}, \boldsymbol{\beta}, \boldsymbol{\gamma}, \mathbf{u}, \mathfrak{t})$$

subordinate to (\mathbb{I}, \mathbb{S}) . Let us denote by $W_{\alpha\beta\gamma}$ the 4-manifold obtained from the Heegaard triple \mathcal{H} . There is an epimorphism

$$\pi : H_1(M_{\alpha\beta} \amalg M_{\beta\gamma} \amalg M_{\alpha\gamma}, \mathbb{Z})/\text{Tors} \longrightarrow H_1(W_{\alpha\beta\gamma}, \mathbb{Z})/\text{Tors} = H_1(W, \mathbb{Z})/\text{Tors}.$$

Every element $\zeta \in H_1(W, \mathbb{Z})/\text{Tors}$ may be represented as $\pi(\zeta_{\alpha\beta}, \zeta_{\beta\gamma}, \zeta_{\alpha\gamma})$ with

$$(\zeta_{\alpha\beta}, \zeta_{\beta\gamma}, \zeta_{\alpha\gamma}) \in H_1(M_{\alpha\beta} \amalg M_{\beta\gamma} \amalg M_{\alpha\gamma}, \mathbb{Z})/\text{Tors}.$$

We may then define

$$\begin{aligned} \mathfrak{f}_{\mathcal{H}}^{\zeta} &: \text{HF}(\Sigma, \boldsymbol{\alpha}, \boldsymbol{\beta}, \mathbf{u}, \mathfrak{t}|_{M_{\alpha\beta}}) \longrightarrow \text{HF}(\Sigma, \boldsymbol{\alpha}, \boldsymbol{\gamma}, \mathbf{u}, \mathfrak{t}|_{M_{\alpha\gamma}}) \\ \mathfrak{f}_{\mathcal{H}}^{\zeta}(\mathbf{x}) &:= \mathfrak{f}_{\alpha\beta\gamma}((\zeta_{\alpha\beta} \cdot \mathbf{x}) \otimes \Theta_{\beta\gamma} + \mathbf{x} \otimes (\zeta_{\beta\gamma} \cdot \Theta_{\beta\gamma})) - \zeta_{\alpha\gamma} \cdot \mathfrak{f}_{\alpha\beta\gamma}(\mathbf{x} \otimes \Theta_{\beta\gamma}). \end{aligned}$$

Correspondingly, we may define

$$\bar{\mathfrak{f}}_{\mathcal{H}}^{\mathbb{M}} : \text{HF}^{\mathbb{M}}(\mathcal{T}_1) \otimes \Lambda^*(H_1(W, \mathbb{Z})/\text{Tors}) \longrightarrow \text{HF}^{\mathbb{M}}(\mathcal{T}_2), \quad \bar{\mathfrak{f}}_{\mathcal{H}}^{\mathbb{M}}(\mathbf{x} \otimes \zeta) := \mathfrak{f}_{\mathcal{H}}^{\zeta}(\mathbf{x}).$$

It is then implied by [OS06, Lemma 2.6] that the above map is in fact well-defined, and does not depend on the representation of ζ as $\pi(\zeta_{\alpha\beta}, \zeta_{\beta\gamma}, \zeta_{\alpha\gamma})$. After composing with the maps $\mathfrak{f}_{\mathcal{C}_1}^{\mathbb{M}}$ and $\mathfrak{f}_{\mathcal{C}_3}^{\mathbb{M}}$ we obtain an induced map, which may be denoted by

$$\bar{\mathfrak{f}}_{\mathcal{C}}^{\mathbb{M}} : \text{HF}^{\mathbb{M}}(\mathcal{T}) \otimes \Lambda^*(H_1(W, \mathbb{Z})/\text{Tors}) \longrightarrow \text{HF}^{\mathbb{M}}(\mathcal{T}').$$

We may then follow the steps taken in [OS06] to show the invariance of the map $\bar{\mathfrak{f}}_{\mathcal{C}}^{\mathbb{M}}$ and show that $\bar{\mathfrak{f}}_{\mathcal{C}}^{\mathbb{M}}$ is also well-defined.

7.5. Relative Spin^c structures and the cobordism map. Suppose $\mathcal{W} = (W, F)$ is a stable cobordism from a balanced tangle (M^0, T^0) to a balanced tangle (M^1, T^1) . Let (X^i, τ^i) be the sutured manifold associated with (M^i, T^i) for $i = 0, 1$. Specifically, $X^i = M^i \setminus \text{nd}(T^i)$ for a tubular neighborhood $\text{nd}(T^i)$ around T^i . Moreover, if $T^i = \amalg_{j=1}^{\kappa} T_j^i$, then $\tau^i = \amalg_{j=1}^{\kappa} \tau_j^i$ where $\tau_j^i \subset \partial \text{nd}(T^i)$ is the meridian of T_j^i for each $1 \leq j \leq \kappa$.

Denote the Poincaré dual of the homology class $[\tau_j^i] \in H_1(X^i, \mathbb{Z})$ by $\chi_j^i \in H^2(X^i, \partial X^i, \mathbb{Z})$. Recall that the set of relative Spin^c classes on (M^i, T^i) , denoted by $\text{Spin}^c(M^i, T^i)$, is an affine space over $H^2(X^i, \partial X^i, \mathbb{Z})$ and sits in the exact sequence

$$0 \longrightarrow \langle \chi_j^i \mid 1 \leq j \leq \kappa \rangle_{\mathbb{Z}} \longrightarrow \text{Spin}^c(M^i, T^i) \longrightarrow \text{Spin}^c(M^i) \longrightarrow 0.$$

The surface F induces an equivalence relation on the components of T^i by setting $T_j^i \sim T_k^i$ if they are subsets of the boundary of the same component of F . Let

$$\mathcal{I}_i = \langle \chi_j^i - \chi_k^i \mid T_j^i \sim T_k^i \rangle \subset H^2(X^i, \partial X^i, \mathbb{Z})$$

and define

$$(7) \quad \text{Spin}_F^c(M^i, T^i) := \frac{\text{Spin}^c(M^i, T^i)}{\mathcal{I}_i} \quad \text{and} \quad \mathbb{H}_F^i := \frac{H^2(X^i, \partial X^i, \mathbb{Z})}{\mathcal{I}_i}.$$

Consequently, if $F = \amalg_{j=1}^m F_j$, each component F_j of F determines a equivalence class in \mathbb{H}_F^i , denoted by η_j^i .

Correspondingly, this equivalence relation specifies an \mathbb{F} -algebra ($\mathbb{F} = \mathbb{Z}/2\mathbb{Z}$), denoted by \mathbb{A}_F , which is isomorphic to a quotient of $\mathbb{A}_i = \mathbb{A}_{(M^i, T^i)} \otimes_{\mathbb{Z}} \mathbb{F}$ by the ideal determined by \sim . More precisely, consider the polynomial ring $\mathbb{F}[\mathbf{u}_1, \dots, \mathbf{u}_m]$. If $\partial^+ M^0 = \amalg_{i=1}^k S_i^-$ and $\partial^- M^0 = \amalg_{j=1}^l S_j^+$, then

$$\partial_h^- W = \amalg_{i=1}^k S_i^- \times [0, 1] \quad \text{and} \quad \partial_h^+ W = \amalg_{j=1}^l S_j^+ \times [0, 1].$$

Associated with any connected component of $\partial_h W$, we define

$$\mathbf{u}_i^- := \prod_{F_j \cap S_i^- \neq \emptyset} \mathbf{u}_j \quad \text{for } 1 \leq i \leq k, \quad \mathbf{u}_i^+ := \prod_{F_j \cap S_i^+ \neq \emptyset} \mathbf{u}_j \quad \text{for } 1 \leq i \leq l.$$

If we set $\mathbf{u}^- = \sum_{i=1}^k \mathbf{u}_i^-$ and $\mathbf{u}^+ = \sum_{i=1}^l \mathbf{u}_i^+$, it follows that

$$(8) \quad \mathbb{A}_F := \frac{\mathbb{F}[\mathbf{u}_1, \dots, \mathbf{u}_m]}{\langle \mathbf{u}_i^- \mid g(S_i^-) > 0 \rangle + \langle \mathbf{u}_i^+ \mid g(S_i^+) > 0 \rangle + \langle \mathbf{u}^+ - \mathbf{u}^- \rangle}.$$

The map $\mathbf{u}_F : \pi_0(F) \rightarrow \mathbb{A}_F$ mapping F_i to \mathbf{u}_i for $i = 1, \dots, m$, is an \mathbb{A}_F -coloring on (W, F) . Thus, $\mathcal{C} = [W, F, \mathfrak{t}, \mathbf{u}_F]$ is an \mathbb{A}_F -cobordism for every $\mathfrak{t} \in \text{Spin}^c(W)$. Let $\mathbf{u}^i : \pi_0(T^i) \rightarrow \mathbb{A}_F$ denote the \mathbb{A}_F -coloring induced by \mathbf{u}_F on (M^i, T^i) . Associated with this coloring, there is a natural filtration on \mathbb{A}_F by \mathbb{H}_F^i defined by

$$\chi^i : G(\mathbb{A}_F) \rightarrow \mathbb{H}_F^i = H^2(X^i, \partial X^i, \mathbb{Z}) \quad \chi^i \left(\prod_{j=1}^m \mathbf{u}_j^{a_j} \right) := \sum_{j=1}^m a_j \eta_j^i,$$

see [AE15, Section 3.2]. Thus, for any Spin^c class $\mathfrak{s}^i \in \text{Spin}^c(M^i)$ we have

$$\text{HF}(M^i, T^i, \mathfrak{s}^i, \mathbf{u}^i) = \bigoplus_{\underline{\mathfrak{s}}^i \in \mathfrak{s}^i \subset \text{Spin}_F^c(M^i, T^i)} \text{HF}(M^i, T^i, \underline{\mathfrak{s}}^i, \mathbf{u}^i)$$

Lemma 7.7. *Consider the \mathbb{A}_F -cobordism $\mathcal{C} = [W, F, \mathfrak{t}, \mathbf{u}_F]$ as above and let $\mathfrak{s}^0 = \mathfrak{t}|_{M^0}$ and $\mathfrak{s}^1 = \mathfrak{t}|_{M^1}$. Suppose that for an element \mathbf{x} in $\text{HF}(M^0, T^0, \underline{\mathfrak{s}}^0, \mathbf{u}^0)$ with $\underline{\mathfrak{s}}^0 \in \mathfrak{s}^0$ we have $\mathfrak{f}_{\mathcal{C}}(\mathbf{x}) \in \text{HF}(M^1, T^1, \underline{\mathfrak{s}}^1, \mathbf{u}^1)$ where $\underline{\mathfrak{s}}^1 \in \mathfrak{s}^1$. Then, $\mathfrak{f}_{\mathcal{C}}$ induces the maps*

$$\mathfrak{f}_{\mathcal{C}} : \text{HF}(M^0, T^0, \underline{\mathfrak{s}}^0 + \sum_{j=1}^m a_j \eta_j^0, \mathbf{u}^0) \rightarrow \text{HF}(M^1, T^1, \underline{\mathfrak{s}}^1 + \sum_{j=1}^m a_j \eta_j^1, \mathbf{u}^1),$$

for every choice of $a_1, \dots, a_m \in \mathbb{Z}$.

Proof. It is enough to prove the lemma in the case where (W, F) is determined by (\mathbb{I}, \mathbb{S}) , for an acceptable set of framed arcs \mathbb{I} and a framed link \mathbb{S} . Let

$$\mathcal{H} = (\Sigma, \alpha, \beta, \gamma, \mathfrak{t}, u_F)$$

be an \mathbb{A}_F -diagram for \mathcal{C} whose underlying Heegaard triple is subordinate to (\mathbb{I}, \mathbb{S}) . Further, assume that the distinguished generator $\Theta_{\beta\gamma}$ is represented by an intersection point $\theta_{\beta\gamma} \in \mathbb{T}_\beta \cap \mathbb{T}_\gamma$ and the marked points in \mathbf{z} are labelled such that z_i corresponds to T_i^0 . Consider the intersection points $\mathbf{x}, \mathbf{y} \in \mathbb{T}_\alpha \cap \mathbb{T}_\beta$ and let

$$\underline{\mathfrak{s}}(\mathbf{y}) - \underline{\mathfrak{s}}(\mathbf{x}) = \sum_{j=1}^m a_j \eta_j^0,$$

where $a_j \in \mathbb{Z}$ for all j . Here, abusing the notation $\underline{\mathfrak{s}}(\cdot)$ denotes the equivalence class of the relative Spin^c structure represented by the corresponding generator. Let $\Delta_x \in \pi_2(\mathbf{x}, \Theta_{\beta\gamma}, \mathbf{x}')$ and $\Delta_y \in \pi_2(\mathbf{y}, \Theta_{\beta\gamma}, \mathbf{y}')$ be triangle classes representing the Spin^c structure \mathfrak{t} for some $\mathbf{x}', \mathbf{y}' \in \mathbb{T}_\alpha \cap \mathbb{T}_\gamma$. Then, there are disks $\phi \in \pi_2(\mathbf{y}, \mathbf{x})$ and $\psi \in \pi_2(\mathbf{x}', \mathbf{y}')$ such that $\Delta_y = \phi \star \Delta_x \star \psi$. Since $a_j = n_j(\phi) = \sum_{T_i^0 \subset \partial F_j} n_{z_i}(\phi)$,

$$\begin{aligned} \underline{\mathfrak{s}}\left(\prod_{j=1}^m u_j^{n_j(\Delta_y)} \cdot \mathbf{y}'\right) - \underline{\mathfrak{s}}\left(\prod_{j=1}^m u_j^{n_j(\Delta_x)} \cdot \mathbf{x}'\right) &= \sum_{j=1}^m (n_j(\Delta_y) - n_j(\Delta_x)) \eta_j^1 + \underline{\mathfrak{s}}(\mathbf{y}') - \underline{\mathfrak{s}}(\mathbf{x}') \\ &= \sum_{j=1}^m (n_j(\Delta_y) - n_j(\Delta_x)) \eta_j^1 - \sum_{j=1}^m n_j(\psi) \eta_j^1 \\ &= \sum_{j=1}^m n_j(\phi) \eta_j^1 = \sum_{j=1}^m a_j \eta_j^1 \end{aligned}$$

where $n_j(\Delta_\bullet) = \sum_{T_i^0 \subset \partial F_j} n_{z_i}(\Delta_\bullet)$ for $\bullet = x, y$ and $n_j(\psi) = \sum_{T_i^0 \subset \partial F_j} n_{z_i}(\psi)$. This completes the proof of lemma. \square

8. APPLICATIONS AND SPECIAL CASES

8.1. Cobordisms between closed 3-manifolds. Let $\mathcal{Y} = (Y, p)$ be an oriented, closed 3-manifold Y with a based point $p \in Y$. Associated with \mathcal{Y} , there is a balanced tangle (Y_p, T_p) defined as follows. Let $p_-, p_+ \in Y$ be points close to p and $T \subset Y$ be an embedded oriented arc passing through p such that $\partial^- T = p_-$ and $\partial^+ T = p_+$. Then, Y_p is constructed by removing small disjoint balls (also disjoint from p) around p_- and p_+ and $T_p = T \cap Y_p$. Note that $\partial^- Y_p$ and $\partial^+ Y_p$ are the boundary of spheres around p_- and p_+ , respectively, and T_p has one connected component. So, there is an obvious $\mathbb{F}[\mathbf{u}]$ -coloring on (Y_p, T_p) labeling T_p by \mathbf{u} . Here, as before $\mathbb{F} = \mathbb{Z}/2\mathbb{Z}$. Let $\mathcal{T}_{\mathcal{Y}, \mathfrak{s}} = (Y_p, T_p, \mathfrak{s}, \mathbf{u}_p)$ for every $\mathfrak{s} \in \text{Spin}^c(Y)$.

Definition 8.1. Let $\mathcal{Y} = (Y, p)$ and $\mathcal{Y}' = (Y', p')$ be oriented, closed, based 3-manifolds. A *decorated cobordism* $\mathcal{X} = (X, \sigma)$ from \mathcal{Y} to \mathcal{Y}' is a smooth, oriented 4-manifold X with $\partial X = -Y \amalg Y'$ and a properly embedded arc $\sigma \subset X$ such that $\partial \sigma = p \amalg p'$.

Associated with any decorated cobordism $\mathcal{X} = (X, \sigma)$ from $\mathcal{Y} = (Y, p)$ to $\mathcal{Y}' = (Y', p')$ one may construct a stable cobordism (X_σ, F_σ) from (Y_p, T_p) to (Y'_p, T'_p) , as follows. Let $T \subset Y$ and $T' \subset Y'$ be embedded, oriented arcs containing p and p' respectively, and let $\partial^\bullet T = p_\bullet$ and $\partial^\bullet T' = p'_\bullet$ for $\bullet = +, -$. Consider parallel disjoint copies of σ in X , denoted by σ^- and σ^+ , such that $\partial \sigma^- = p_- \amalg p'_-$, $\partial \sigma^+ = p_+ \amalg p'_+$ and $\sigma^- \cup T' \cup \sigma^+ \cup T$ bounds an embedded disk D in X . Then, X_σ is obtained from X by removing small, disjoint tubular neighborhoods around σ^- and σ^+ , while $F_\sigma = D \cap X_\sigma$. Let \mathbf{u}_σ denote the $\mathbb{F}[\mathbf{u}]$ -coloring on (X_σ, F_σ) which labels F_σ by \mathbf{u} , and set $\mathcal{C}_{\mathcal{X}, \mathfrak{t}} = (X_\sigma, F_\sigma, \mathfrak{t}, \mathbf{u}_\sigma)$ for every $\mathfrak{t} \in \text{Spin}^c(X)$.

For every closed, oriented, based 3-manifold $\mathcal{Y} = (Y, p)$ and every $\mathfrak{s} \in \text{Spin}^c(Y)$, the homology groups $\text{HF}^{\mathbb{M}}(\mathcal{T}_{\mathcal{Y}, \mathfrak{s}})$, for \mathbb{M} equal to \mathbb{F} , $\mathbb{F}[\mathbf{u}]$, $\mathbb{F}[\frac{1}{\mathbf{u}}]$ or $\mathbb{F}[\mathbf{u}, \frac{1}{\mathbf{u}}]$, are equal to $\widehat{\text{HF}}(Y, \mathfrak{s}; \mathbb{F})$, $\text{HF}^-(Y, \mathfrak{s}; \mathbb{F})$, $\text{HF}^+(Y, \mathfrak{s}; \mathbb{F})$ and $\text{HF}^\infty(Y, \mathfrak{s}; \mathbb{F})$, respectively. Moreover, for every decorated cobordism $\mathcal{X} = (X, \sigma)$ from (Y, p) to (Y', p') and every Spin^c structure $\mathfrak{t} \in \text{Spin}^c(X)$, the cobordism map $\mathfrak{f}_{\mathcal{C}_{\mathcal{X}, \mathfrak{t}}}^{\mathbb{M}}$ is the cobordism map of Ozsváth and Szabó in any of the aforementioned cases.

8.2. Functoriality of link Floer homology. Another important example of \mathbb{A} -tangles is given by multi-pointed links.

Definition 8.2. A *multi-pointed link* is a triple $\mathcal{L} = (Y, L, \mathbf{p})$ where L is an oriented link in a closed, connected, oriented 3-manifold Y together with a finite set $\mathbf{p} \subset L$ of based points such that every component of L contains at least one base point.

Associated with any multi-pointed link $\mathcal{L} = (Y, L, \mathbf{p})$ we define a balanced tangle $(Y_{\mathbf{p}}, L_{\mathbf{p}})$ as follows. Assume $\mathbf{p} = \{p_1, \dots, p_n\}$ and consider n pairwise of disjoint arc segments $I = \amalg_{i=1}^n I_i$ in L such that $p_i \in I_i$. Using the orientation induced from L on I , let $\mathbf{p}_- = \partial^- I$ and $\mathbf{p}_+ = \partial^+ I$. Then, $Y_{\mathbf{p}}$ is obtained from Y by removing small disjoint ball neighborhoods around the points in \mathbf{p}_- and \mathbf{p}_+ and $\partial^\bullet Y_{\mathbf{p}} \subset \partial Y_{\mathbf{p}}$ is the union of sphere boundary components around \mathbf{p}_\bullet for $\bullet = +, -$. Furthermore,

$$L_{\mathbf{p}} = -((L \setminus I) \cap Y_{\mathbf{p}}) \amalg (I \cap Y_{\mathbf{p}}).$$

Definition 8.3. A *decorated cobordism* from $\mathcal{L} = (Y, L, \mathbf{p})$ to $\mathcal{L}' = (Y', L', \mathbf{p}')$ is a triple $\mathcal{F} = (X, F, \sigma)$ as follows.

- (1) X is a smooth, oriented 4-manifold with $\partial X = -Y \amalg Y'$.
- (2) $F \subset X$ is a smoothly embedded, oriented surface such that $\partial F = -L \amalg L'$.
- (3) $\sigma \subset F$ is a union of embedded, pairwise disjoint, oriented arcs such that $\partial^- \sigma = \mathbf{p}$, $\partial^+ \sigma = \mathbf{p}'$ and every component of $F \setminus \sigma$ with positive genus intersects more than one component of $L \setminus \mathbf{p}$ and $L' \setminus \mathbf{p}'$.

To any decorated cobordism $\mathcal{F} = (X, F, \sigma)$ from $\mathcal{L} = (Y, L, \mathbf{p})$ to $\mathcal{L}' = (Y', L', \mathbf{p}')$, we assign a cobordism (X_σ, F_σ) from the tangle $(Y_{\mathbf{p}}, L_{\mathbf{p}})$ to $(Y'_{\mathbf{p}'}, L'_{\mathbf{p}'})$. We choose the labeling for $\mathbf{p} = \amalg_{i=1}^n p_i$, $\mathbf{p}' = \amalg_{i=1}^n p'_i$ and $\sigma = \amalg_{i=1}^n \sigma_i$ such that $\partial \sigma_i = p_i \amalg p'_i$ for all $1 \leq i \leq n$. Let $I = \amalg_{i=1}^n I_i$ and

$I' = \amalg_{i=1}^n I'_i$ where $I_i \subset L$ and $I'_i \subset L'$ are connected segments containing p_i and p'_i , respectively. Let

$$\mathbf{p}_\bullet = \partial^\bullet I = \amalg_{i=1}^n p_{i\bullet} \quad \text{and} \quad \mathbf{p}'_\bullet = \partial^\bullet I' = \amalg_{i=1}^n p'_{i\bullet}$$

where $p_{i\bullet} = \partial^\bullet I_i$ and $p'_{i\bullet} = \partial^\bullet I'_i$ for $\bullet = -, +$. Consider parallel copies $\sigma_i^-, \sigma_i^+ \subset F$ of each σ_i such that $\partial \sigma_i^\bullet = p_{i\bullet} \amalg p'_{i\bullet}$ for $\bullet = -, +$. Moreover, $\sigma_i^- \cup \sigma_i^+ \cup I_i \cup I'_i$ bounds a disk $D_i \subset F$ containing σ_i such that D_1, \dots, D_n are pairwise disjoint. Let $F^\circ = F \setminus (\amalg_{i=1}^n D_i) = \amalg_{j=1}^m F_j^\circ$. For each $1 \leq i \leq n$, $m^\bullet(i)$ is defined such that $\sigma_i^\bullet \subset \partial F_{m^\bullet(i)}^\circ$ where $\bullet = +, -$.

Then, X_σ is constructed from X by removing disjoint small tubular neighborhood of the arcs $\amalg_{i=1}^n (\sigma_i^- \amalg \sigma_i^+)$ while

$$F_\sigma = -(F^\circ \cap X_\sigma) \amalg (\amalg_{i=1}^n D_i \cap X_\sigma).$$

Abusing the notation, we denote $D_i \cap X_\sigma$ by D_i and $F_j^\circ \cap X_\sigma$ by F_j° where $F^\circ = \amalg_{j=1}^m F_j^\circ$. The algebra associated to the cobordism (X_σ, F_σ) , defined as in Equation 8, is equal to

$$\mathbb{A} = \frac{\mathbb{F}[\mathbf{v}_1, \dots, \mathbf{v}_m, \mathbf{u}_1, \dots, \mathbf{u}_n]}{\sum_{i=1}^n \mathbf{u}_i \mathbf{v}_{m^+(i)} - \sum_{i=1}^n \mathbf{u}_i \mathbf{v}_{m^-(i)}},$$

and the map $\mathbf{u}_\sigma : \pi_0(F_\sigma) \rightarrow \mathbb{A}$, defined by

$$\begin{cases} \mathbf{u}(F_j^\circ) = \mathbf{v}_j & 1 \leq j \leq m \\ \mathbf{u}(D_i) = \mathbf{u}_i & 1 \leq i \leq n, \end{cases}$$

is an \mathbb{A} -coloring on (X_σ, F_σ) . So, $\mathcal{C}_{\mathcal{F}, \mathbf{t}} = [W_\sigma, F_\sigma, \mathbf{t}, \mathbf{u}_\sigma]$ is an \mathbb{A} -cobordism for every $\mathbf{t} \in \text{Spin}^c(X)$. Let $\mathcal{T}_{\mathcal{L}, \mathfrak{s}}$ (respectively $\mathcal{T}_{\mathcal{L}', \mathfrak{s}'}$) denote the \mathbb{A} -tangle obtained from equipping $(Y_{\mathbf{p}}, L_{\mathbf{p}})$ (respectively $(Y'_{\mathbf{p}'}, L'_{\mathbf{p}'})$) with the coloring induced from \mathbf{u}_σ and the Spin^c structure $\mathfrak{s} = \mathbf{t}|_Y$ (respectively $\mathfrak{s}' = \mathbf{t}|_{Y'}$).

Then for every \mathbb{A} -module \mathbb{M} we have an \mathbb{A} -homomorphism

$$\mathfrak{f}_{\mathcal{C}_{\mathcal{F}, \mathbf{t}}}^{\mathbb{M}} : \text{HF}^{\mathbb{M}}(\mathcal{T}_{\mathcal{L}, \mathfrak{s}}) \rightarrow \text{HF}^{\mathbb{M}}(\mathcal{T}_{\mathcal{L}', \mathfrak{s}'}).$$

For $\mathbb{M} = \mathbb{A}$, following the discussions of Section 7.5, the chain complexes $\text{CF}(\mathcal{T}_{\mathcal{L}, \mathfrak{s}})$ and $\text{CF}(\mathcal{T}_{\mathcal{L}', \mathfrak{s}'})$ are $(\mathbb{A}, \mathbb{H}_F)$ and $(\mathbb{A}, \mathbb{H}'_F)$ filtered chain complexes where \mathbb{H}_F and \mathbb{H}'_F are defined as in Equation 7. Moreover, the cobordism map $\mathfrak{f}_{\mathcal{C}_{\mathcal{F}, \mathbf{t}}}$ preserves the relative filtration in the sense of Lemma 7.7. In particular, for $\mathbb{M} = \mathbb{F}[\mathbf{u}_1, \dots, \mathbf{u}_n]$ which has the structure of an \mathbb{A} -module via the homomorphism $\phi : \mathbb{A} \rightarrow \mathbb{M}$ which maps all \mathbf{v}_i to zero, we obtain an invariant homomorphism

$$\mathfrak{f}_{\mathcal{C}_{\mathcal{F}, \mathbf{t}}} = \mathfrak{f}_{\mathcal{C}_{\mathcal{F}, \mathbf{t}}}^{\mathbb{F}[\mathbf{u}_1, \dots, \mathbf{u}_n]} : \text{HFL}^-(Y, L, \mathbf{p}, \mathfrak{s}) \rightarrow \text{HFL}^-(Y', L', \mathbf{p}', \mathfrak{s}').$$

REFERENCES

- [AD] Akram Alishahi and Nathan Dowlin, *The Lee spectral sequence, unknotting number, and the knight move conjecture*, arXiv:1710.07875.
- [AE] Akram Alishahi and Eaman Eftekhary, *Knot Floer homology and the unknotting number*, in preparation.
- [AE15] ———, *A refinement of sutured floer homology*, J. Symplectic Geom. **13** (2015), no. 3, 609–743.
- [Ali] Akram Alishahi, *The Bar-Natan homology and unknotting number*, arXiv:1710.07874.
- [Cer70] Jean Cerf, *La stratification naturelle des espaces de fonctions différentiables réelles et le théorème de la pseudo-isotopie*, Inst. Hautes Études Sci. Publ. Math. (1970), no. 39, 5–173.
- [Eft05] Eaman Eftekhary, *Longitude Floer homology and the Whitehead double*, Algebr. Geom. Topol. **5** (2005), 1389–1418.
- [Gab83] David Gabai, *Foliations and the topology of 3-manifolds*, J. Differential Geom. **18** (1983), no. 3, 445–503.
- [Gab87a] ———, *Foliations and the topology of 3-manifolds. II*, J. Differential Geom. **26** (1987), no. 3, 461–478.
- [Gab87b] ———, *Foliations and the topology of 3-manifolds. III*, J. Differential Geom. **26** (1987), no. 3, 479–536.
- [GK15] David T. Gay and Robion Kirby, *Indefinite Morse 2-functions: broken fibrations and generalizations*, Geom. Topol. **19** (2015), no. 5, 2465–2534.
- [GW10] J. Elisenda Grigsby and Stephan M. Wehrli, *On the colored Jones polynomial, sutured Floer homology, and knot Floer homology*, Adv. Math. **223** (2010), no. 6, 2114–2165.
- [GWW13] David Gay, Katrin Wehrheim, and Chris Woodward, *Connected cerf theory*, preprint, 2013.
- [JT] András Juhász and Dylan P. Thurston, *Naturality and mapping class groups in heegaard floer homology*, arXiv:1210.4996.
- [Juh] András Juhász, *Defining and classifying tqfts via surgery*, arXiv:1408.0668.
- [Juh06] ———, *Holomorphic discs and sutured manifolds*, Algebr. Geom. Topol. **6** (2006), 1429–1457.
- [Juh08] András Juhász, *Floer homology and surface decompositions*, Geom. Topol. **12** (2008), no. 1, 299–350.
- [Lip06] Robert Lipshitz, *A cylindrical reformulation of Heegaard Floer homology*, Geom. Topol. **10** (2006), 955–1097.
- [Mil65] John Milnor, *Lectures on the h-cobordism theorem*, Notes by L. Siebenmann and J. Sondow, Princeton University Press, Princeton, N.J., 1965.
- [OS04a] Peter Ozsváth and Zoltán Szabó, *Holomorphic disks and knot invariants*, Adv. Math. **186** (2004), no. 1, 58–116.
- [OS04b] ———, *Holomorphic disks and three-manifold invariants: properties and applications*, Ann. of Math. (2) **159** (2004), no. 3, 1159–1245.
- [OS04c] ———, *Holomorphic disks and topological invariants for closed three-manifolds*, Ann. of Math. (2) **159** (2004), no. 3, 1027–1158.
- [OS05] ———, *Heegaard Floer homology and contact structures*, Duke Math. J. **129** (2005), no. 1, 39–61.
- [OS06] ———, *Holomorphic triangles and invariants for smooth four-manifolds*, Adv. Math. **202** (2006), no. 2, 326–400.
- [OS08] ———, *Holomorphic disks, link invariants and the multi-variable Alexander polynomial*, Algebr. Geom. Topol. **8** (2008), no. 2, 615–692.
- [Ras02] Jacob Andrew Rasmussen, *Floer homology of surgeries on two-bridge knots*, Algebr. Geom. Topol. **2** (2002), 757–789.
- [Zem] Ian Zemke, *Link cobordisms and functoriality in link floer homology*, arXiv:1610.05207.

DEPARTMENT OF MATHEMATICS, COLUMBIA UNIVERSITY, NEW YORK, NY 10027

E-mail address: alishahi@math.columbia.edu

SCHOOL OF MATHEMATICS, INSTITUTE FOR RESEARCH IN FUNDAMENTAL SCIENCES (IPM), P. O. BOX 19395-5746, TEHRAN, IRAN

E-mail address: eaman@ipm.ir